

A
B
C

SECTION **PB**

PARKING BRAKE SYSTEM

CONTENTS

<p>PRECAUTION 2</p> <p>PRECAUTIONS 2</p> <p style="padding-left: 20px;">Precaution for Supplemental Restraint System (SRS) "AIR BAG" and "SEAT BELT PRE-TENSIONER"2</p> <p>PREPARATION 3</p> <p>PREPARATION 3</p> <p style="padding-left: 20px;">Commercial Service Tool3</p> <p>PERIODIC MAINTENANCE 4</p> <p>PARKING BRAKE SYSTEM 4</p> <p style="padding-left: 20px;">Inspection and Adjustment4</p> <p>PARKING BRAKE SHOE 6</p> <p style="padding-left: 20px;">Inspection and Adjustment6</p> <p>REMOVAL AND INSTALLATION 7</p> <p>PARKING BRAKE CONTROL 7</p> <p style="padding-left: 20px;">Exploded View7</p>	<p style="padding-left: 20px;">Removal and Installation 7</p> <p>PARKING BRAKE FRONT CABLE 8</p> <p style="padding-left: 20px;">Removal and Installation 8</p> <p>PARKING BRAKE REAR CABLE 9</p> <p style="padding-left: 20px;">Removal and Installation 9</p> <p>PARKING BRAKE SWITCH10</p> <p style="padding-left: 20px;">Removal and Installation10</p> <p>PARKING BRAKE SHOE11</p> <p style="padding-left: 20px;">Exploded View11</p> <p style="padding-left: 20px;">Removal and Installation11</p> <p style="padding-left: 20px;">Inspection12</p> <p>SERVICE DATA AND SPECIFICATIONS (SDS)14</p> <p>SERVICE DATA AND SPECIFICATIONS (SDS)14</p> <p style="padding-left: 20px;">Parking Drum Brake14</p> <p style="padding-left: 20px;">Parking Brake Control14</p>
---	--

PB
G
H
I
J
K
L
M
N
O
P

PRECAUTIONS

< PRECAUTION >

PRECAUTION

PRECAUTIONS

Precaution for Supplemental Restraint System (SRS) "AIR BAG" and "SEAT BELT PRE-TENSIONER"

INFOID:000000011564760

The Supplemental Restraint System such as "AIR BAG" and "SEAT BELT PRE-TENSIONER", used along with a front seat belt, helps to reduce the risk or severity of injury to the driver and front passenger for certain types of collision. Information necessary to service the system safely is included in the SR and SB section of this Service Manual.

WARNING:

- To avoid rendering the SRS inoperative, which could increase the risk of personal injury or death in the event of a collision which would result in air bag inflation, all maintenance must be performed by an authorized NISSAN/INFINITI dealer.
- Improper maintenance, including incorrect removal and installation of the SRS, can lead to personal injury caused by unintentional activation of the system. For removal of Spiral Cable and Air Bag Module, see the SR section.
- Do not use electrical test equipment on any circuit related to the SRS unless instructed to in this Service Manual. SRS wiring harnesses can be identified by yellow and/or orange harnesses or harness connectors.

PRECAUTIONS WHEN USING POWER TOOLS (AIR OR ELECTRIC) AND HAMMERS

WARNING:

- When working near the Airbag Diagnosis Sensor Unit or other Airbag System sensors with the Ignition ON or engine running, DO NOT use air or electric power tools or strike near the sensor(s) with a hammer. Heavy vibration could activate the sensor(s) and deploy the air bag(s), possibly causing serious injury.
- When using air or electric power tools or hammers, always switch the Ignition OFF, disconnect the battery and wait at least three minutes before performing any service.

PREPARATION

< PREPARATION >



PREPARATION

PREPARATION

Commercial Service Tool

INFOID:000000011219949

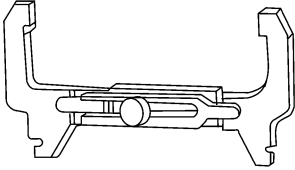
A
B
C
D
E
PB
G
H
I
J
K
L
M
N
O
P

Tool name	Description
<p data-bbox="191 415 415 470">Brake drum clearance gauge</p>  <p data-bbox="727 632 800 646">WFIA0167E</p>	<p data-bbox="911 415 1433 443">Measuring rear disc brake rotor drum inner diameter</p>
<p data-bbox="191 665 302 693">Power tool</p>  <p data-bbox="727 884 800 898">PIIB1407E</p>	<p data-bbox="902 665 1235 693">Loosening nuts, screws and bolts</p>

PARKING BRAKE SYSTEM

< PERIODIC MAINTENANCE >

PERIODIC MAINTENANCE

PARKING BRAKE SYSTEM

Inspection and Adjustment

INFOID:000000011219950

INSPECTION

Pedal Stroke

1. Operate the parking brake pedal with a force of 196 N (20.0 kg-f, 44.1 lb-f). Check that the pedal stroke is within the specified number of notches. (Check it by listening to the clicks of the ratchet.)

Number of notches : Refer to [PB-14, "Parking Brake Control"](#).

2. When brake warning lamp turns ON, check that the pedal stroke is within the specified number of notches. (Check it by listening to the clicks of the ratchet.)

Number of notches : Refer to [PB-14, "Parking Brake Control"](#).

Inspect Components

- Check each component for installation condition such as looseness.
- Check the parking brake pedal assembly for bends, damage and cracks. Replace if necessary.
- Check the cables for wear, damage and cracks. Replace if necessary.
- Check the parking brake switch, and replace it if necessary. Refer to [PB-7, "Removal and Installation"](#).

ADJUSTMENT

1. Secure the disc brake rotor using wheel nuts.
2. Remove fuse block lid. Refer to [IP-15, "Exploded View"](#).
3. Release the parking brake pedal (1) by turning the adjusting nut (2) with a deep socket wrench and loosening the cable.

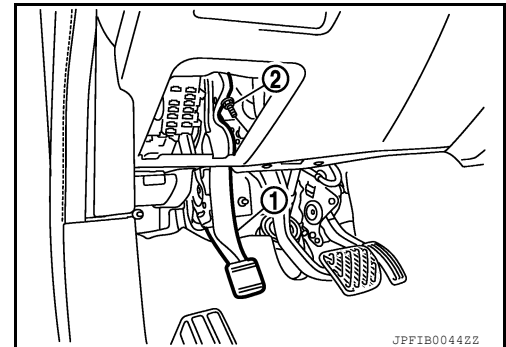

4. Remove the adjusting hole plug from the disc brake rotor. Turn the adjuster (1) in the direction (A) as shown using a suitable tool until the disc brake rotor is locked.
5. Turn back the adjuster 1 notch from the locked position.
6. Rotate the disc brake rotor to check that there is no drag. Install the adjusting hole plug.
7. Adjust the cable with the following procedure:
 - a. Operate the parking brake pedal with a force of 490 N (50.0 kg-f, 110.2 lb-f) for more than 30 minutes.
 - b. Adjust the parking brake pedal stroke by turning the adjusting nut with a deep socket wrench.

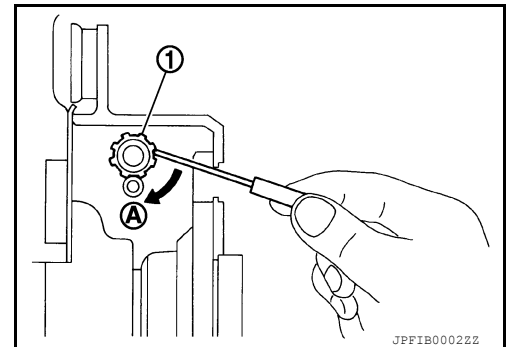

CAUTION:

Do not reuse the adjusting nut if the nut is removed.

- c. Operate the parking brake pedal with a force of 196 N (20.0 kg-f, 44.1 lb-f). Check that the pedal stroke is within the specified number of notches. (Check it by listening to the clicks of the ratchet.)

Number of notches : Refer to [PB-14, "Parking Brake Control"](#).

PARKING BRAKE SYSTEM

< PERIODIC MAINTENANCE >

- d. Rotate the disc brake rotor with the parking brake pedal released and check that there is no drag.

CAUTION:

If any drag is found, verify the parking brake components are installed and adjusted correctly.

A

B

C

D

E

PB

G

H

I

J

K

L

M

N

O

P

PARKING BRAKE SHOE

< PERIODIC MAINTENANCE >

PARKING BRAKE SHOE

Inspection and Adjustment

INFOID:000000011219951

1. Adjust parking brake pedal stroke. Refer to [PB-4, "Inspection and Adjustment"](#).
2. Perform parking brake break-in (drag on) operation by driving vehicle under the following conditions:
 - Drive forward
 - Vehicle speed: Approx. 40 km/h (25 MPH) set (constant and forward)
 - Parking brake operating force: Approx. 140 +49, -0 N (14.3 +5, -0 kg-f, 31.5 +11, -0 lb-f)
 - Time: Approx. 5 +5, -0 seconds.

CAUTION:

To prevent lining from getting too hot, allow a cool off period of approximately 5 minutes after every break-in operation.

3. After the break-in procedure, check parking pedal stroke of parking brake.

CAUTION:

If it is out of the specification, adjust again. Refer to [PB-4, "Inspection and Adjustment"](#).

ADJUSTMENT AFTER INSTALLATION

1. Adjust the parking brake pedal stroke. Refer to [PB-4, "Inspection and Adjustment"](#).
2. Rotate the disc brake rotor with the parking brake pedal released and check that there is no drag.

CAUTION:

If any drag is found, verify the parking brake components are installed and adjusted correctly.

PARKING BRAKE CONTROL

< REMOVAL AND INSTALLATION >

REMOVAL AND INSTALLATION

PARKING BRAKE CONTROL

Exploded View

INFOID:0000000011219952

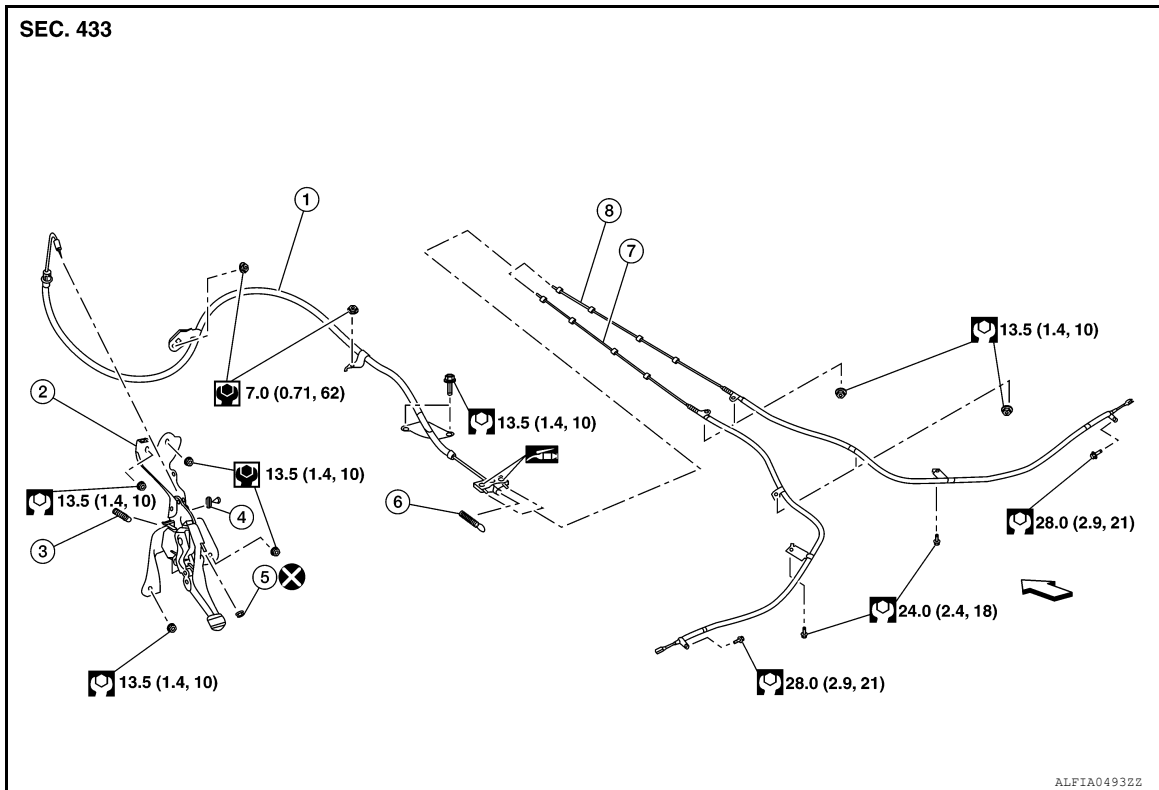

- | | | |
|-------------------------|---------------------------------|--------------------------------------|
| 1. Front cable | 2. Parking brake pedal assembly | 3. Parking brake pedal return spring |
| 4. Parking brake switch | 5. Adjusting nut | 6. Return spring |
| 7. Rear cable (LH) | 8. Rear cable (RH) | |

Removal and Installation

INFOID:0000000011219953

WARNING:

- Always work from the side of air bag module. Do not work in front of it.
- Do not use air tools or electric tools for servicing.

REMOVAL

1. Remove lower instrument panel LH. Refer to [IP-24. "Removal and Installation"](#).
2. Place fuse box aside.
3. Disconnect harness connector from parking brake switch.
4. Remove parking brake pedal assembly nuts and place parking brake pedal assembly aside.
5. Remove adjusting nut from parking brake pedal.
6. Separate front cable from parking brake pedal.
7. Remove parking brake pedal assembly.
8. Remove parking brake switch if necessary.

INSTALLATION

Installation is in the reverse order of removal.

CAUTION:

Do not reuse the adjusting nut.

Adjust parking brake with new adjusting nut. Refer to [PB-4. "Inspection and Adjustment"](#).

PARKING BRAKE FRONT CABLE

< REMOVAL AND INSTALLATION >

PARKING BRAKE FRONT CABLE

Removal and Installation

INFOID:000000011545090

REMOVAL

1. Remove parking brake control. Refer to [PB-7, "Removal and Installation"](#).

NOTE:

It is not necessary to remove parking brake switch.

2. Remove center console. Refer to [IP-19, "Removal and Installation"](#).
3. Place front floor trim (LH) aside. Refer to [INT-25, "Exploded View"](#).
4. Remove retainers from parking brake front cable mount. Refer to [PB-7, "Exploded View"](#).
5. Pull equalizer (A) on parking brake front cable (1) in a rearward direction and then push upward to separate each parking brake rear cable (2) from parking brake front cable (1).

CAUTION:

To prevent damage to the parts, do not bend the parking brake cables.

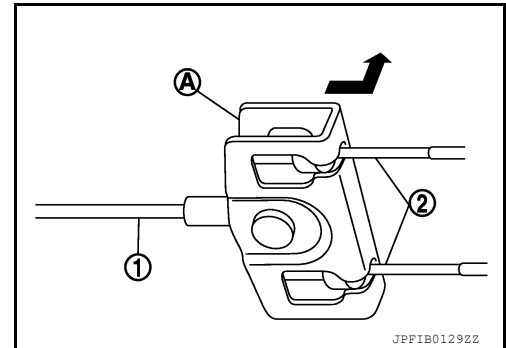

6. For AWD vehicles, remove rear propeller shaft center bearing mounting brackets. Refer to [DLN-89, "Exploded View"](#).
7. Remove parking brake front cable.

INSTALLATION

Installation is in the reverse order of removal.

CAUTION:

Do not reuse the adjusting nut.

After installation, inspect and adjust the parking brake pedal. Refer to [PB-4, "Inspection and Adjustment"](#).

PARKING BRAKE REAR CABLE

< REMOVAL AND INSTALLATION >

PARKING BRAKE REAR CABLE

Removal and Installation

INFOID:000000011545091

REMOVAL

1. Remove center console assembly. Refer to [IP-19. "Removal and Installation"](#).
2. Loosen adjusting nut. Refer to [PB-7. "Exploded View"](#).
3. Pull equalizer (A) on parking brake front cable (1) in a rearward direction and then push upward to separate each parking brake rear cable (2) from the parking brake front cable (1).

NOTE:

It is not necessary to remove parking brake front cable.

CAUTION:

To prevent damage to the parts, do not bend the parking brake cables.

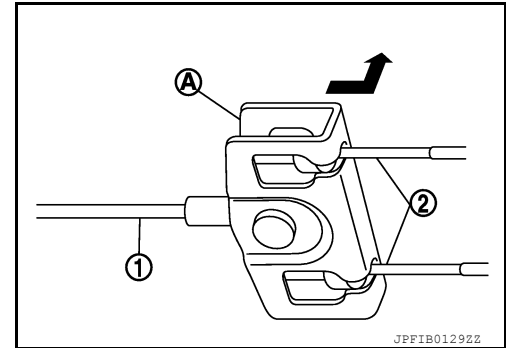

4. For AWD vehicles, remove rear propeller shaft. Refer to [DLN-89. "Removal and Installation"](#).
5. Remove rear disc brake rotor. Refer to [BR-45. "DISC BRAKE ROTOR : Removal and Installation"](#).
6. Separate parking brake rear cable from toggle lever. Refer to [PB-7. "Exploded View"](#).
7. Remove retainers from rear parking brake cable.
8. Remove parking brake rear cable.

INSTALLATION

Installation is in the reverse order of removal.

CAUTION:

Do not reuse the adjusting nut if the nut is removed.

After installation, inspect and adjust the parking brake shoes. Refer to [PB-6. "Inspection and Adjustment"](#).

PARKING BRAKE SWITCH

< REMOVAL AND INSTALLATION >

PARKING BRAKE SWITCH

Removal and Installation

INFOID:000000011545092

REMOVAL

1. Remove lower instrument panel LH. Refer to [IP-24, "Removal and Installation"](#).
2. Place fuse box aside.
3. Disconnect harness connector from parking brake switch.
4. Remove parking brake pedal assembly nuts and place parking brake pedal assembly aside.
5. Remove adjusting nut from parking brake pedal.
6. Remove parking brake switch.

INSTALLATION

Installation is in the reverse order of removal.

CAUTION:

- **Replace the parking brake switch if it has been dropped or sustained an impact.**
- **Do not reuse the adjusting nut.**

Adjust the parking brake cable if necessary. Refer to [PB-4, "Inspection and Adjustment"](#).

PARKING BRAKE SHOE

< REMOVAL AND INSTALLATION >

PARKING BRAKE SHOE

Exploded View

INFOID:000000011219955

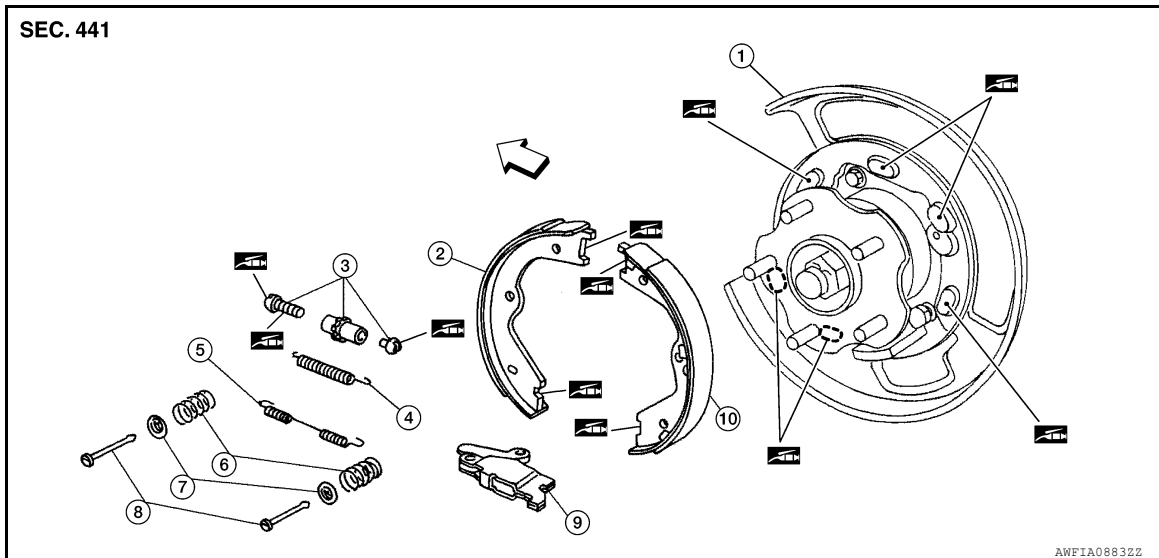

- | | | |
|-------------------------------|-------------------------------|---|
| 1. Back plate | 2. Parking brake shoe (front) | 3. Adjuster |
| 4. Adjuster spring | 5. Return spring | 6. Anti-rattle spring |
| 7. Retainer | 8. Anti-rattle pin | 9. Toggle lever |
| 10. Parking brake shoe (rear) | ↩ Front | Apply PBC (Poly Butyl Cuprysil) grease or silicone-based grease |

Removal and Installation

INFOID:000000011219956

REMOVAL

WARNING:

Clean dust on the parking brake shoes with a vacuum dust collector to minimize the hazard of air borne particles or other materials.

1. Remove rear wheel and tire using power tool. Refer to [WT-68, "Removal and Installation"](#).
2. Remove disc brake rotor. Refer to [BR-45, "DISC BRAKE ROTOR : Removal and Installation"](#).

CAUTION:

Parking brake must be in the completely released position.

3. If disc brake rotor cannot be removed, remove as follows:
 - a. Secure disc brake rotor with wheel nuts and remove adjusting hole plug.
 - b. Using a suitable tool, rotate adjuster (1) in direction (B) to retract and loosen parking brake shoe.
4. Remove anti-rattle pins, retainers, anti-rattle springs, adjuster spring and return spring.

CAUTION:

Do not drop the removed parts.

5. Remove parking brake shoes, adjuster assembly and toggle lever.

CAUTION:

- The parking brake shoes for the front side are made of different materials from those for the rear side. Do not misidentify them when removing.
- Do not drop the removed parts.

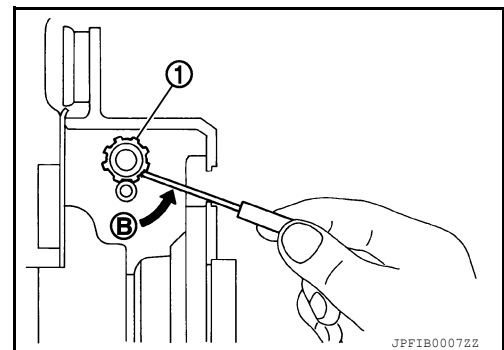

INSTALLATION

Installation is in the reverse order of removal.

PARKING BRAKE SHOE

< REMOVAL AND INSTALLATION >

- Apply PBC (Poly Butyl Cuprysil) grease or silicone-based grease to the back plate and brake shoe.

CAUTION:

The parking brake shoes for the front side are made of different materials from those for the rear side. Do not misidentify them when removing and replacing.

- Assemble adjusters so that threaded part is shortened when rotating it in the direction shown by arrow.

- (A) : For RH brake
- (B) : For LH brake
- ↶ : Front
- ← : Adjuster shortened

- Shorten adjuster by rotating it.
- When assembling the adjuster, apply PBC (Poly Butyl Cuprysil) grease or silicone-based grease to threads and pivot.
- Check parking brake shoe lining and drum inner surface for grease. Wipe off any grease on the surfaces.

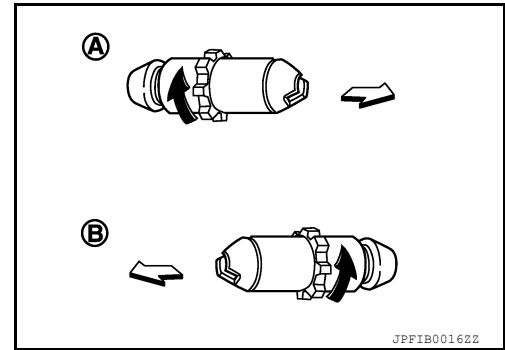

Inspection

INFOID:000000011219957

INSPECTION AFTER REMOVAL

Brake Lining Thickness Inspection

- Check thickness (A) of brake lining.

Limit (A) : Refer to [PB-14, "Parking Drum Brake"](#).

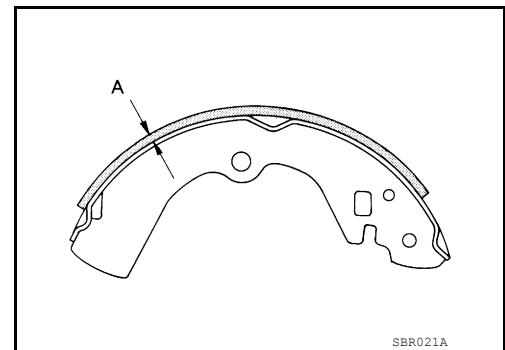

Disc Brake Rotor Drum Inner Diameter Inspection

- Check inner diameter (B) of disc brake rotor drum using suitable tool.

Limit (B) : Refer to [PB-14, "Parking Drum Brake"](#).

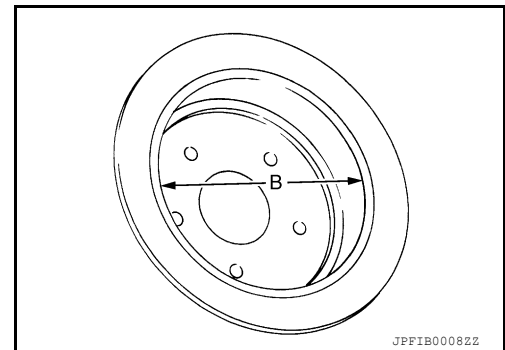

Other Inspections

- Check brake lining for excessive wear, damage, and peeling. Replace if necessary.
- Check parking brake shoe for excessive wear and damage. Replace if necessary.
- Check anti-rattle pins and retainers for excessive wear, damage and rust. Replace if necessary.
- Check adjuster spring, anti-rattle spring and return springs for settling, excessive wear, damage, and rust. Replace if necessary.
- Check adjuster for binding. Replace if necessary.
- Check toggle lever for excessive wear, damage and rust. Replace if necessary.
- Visually check inside the disc brake rotor drum for rust, cracks, damage or excessive wear with a suitable tool. Replace if necessary.

ADJUSTMENT

- Adjust parking brake pedal stroke. Refer to [PB-4, "Inspection and Adjustment"](#).

PARKING BRAKE SHOE

< REMOVAL AND INSTALLATION >

2. Rotate disc brake rotor with parking brake pedal released and check that there is no drag.

CAUTION:

If any drag is found, verify the parking brake components are installed and adjusted correctly.

A

B

C

D

E

PB

G

H

I

J

K

L

M

N

O

P

SERVICE DATA AND SPECIFICATIONS (SDS)

< SERVICE DATA AND SPECIFICATIONS (SDS)

SERVICE DATA AND SPECIFICATIONS (SDS)

SERVICE DATA AND SPECIFICATIONS (SDS)

Parking Drum Brake

INFOID:0000000011219958

Unit: mm (in)

	Item	Limit
Brake lining	Thickness	3.33 (0.131)
	Wear thickness	1.5 (0.059)
Drum	Inner diameter	190 (7.480)
	Wear limit of inner diameter	191 (7.520)

Parking Brake Control

INFOID:0000000011219959

Item	Standard
Number of notches [under force of 196 N (20.0 kg-f, 44.1 lb-f)]	5 – 6 notches
Number of notches when brake warning lamp turns ON	1 notch