

SECTION **PWC**

POWER WINDOW CONTROL SYSTEM

A
B
C
D
E
F
G
H
I
J
L
M
N
O
P

CONTENTS

<p>PRECAUTION 4</p> <p>PRECAUTIONS 4</p> <p style="padding-left: 20px;">Precaution for Supplemental Restraint System (SRS) "AIR BAG" and "SEAT BELT PRE-TENSIONER"4</p> <p style="padding-left: 20px;">Precaution for Work4</p> <p>PREPARATION 5</p> <p>PREPARATION 5</p> <p style="padding-left: 20px;">Special Service Tool5</p> <p>SYSTEM DESCRIPTION 6</p> <p>COMPONENT PARTS 6</p> <p style="padding-left: 20px;">Component Parts Location6</p> <p style="padding-left: 20px;">Main Power Window and Door Lock/Unlock Switch7</p> <p style="padding-left: 20px;">Power Window and Door Lock/Unlock Switch RH.....7</p> <p style="padding-left: 20px;">Rear Power Window Switch7</p> <p style="padding-left: 20px;">Power Window Motor7</p> <p>SYSTEM 8</p> <p style="padding-left: 20px;">System Description8</p> <p style="padding-left: 20px;">Fail-safe 10</p> <p>DIAGNOSIS SYSTEM (BCM)11</p> <p>COMMON ITEM 11</p> <p style="padding-left: 20px;">COMMON ITEM : CONSULT Function (BCM - COMMON ITEM) 11</p> <p>RETAINED PWR12</p> <p style="padding-left: 20px;">RETAINED PWR : CONSULT Function (BCM - RETAINED PWR) 12</p> <p>ECU DIAGNOSIS INFORMATION14</p> <p>BCM (BODY CONTROL MODULE)14</p> <p style="padding-left: 20px;">List of ECU Reference 14</p>	<p>MAIN POWER WINDOW AND DOOR LOCK/UNLOCK SWITCH15</p> <p style="padding-left: 20px;">Reference Value15</p> <p>POWER WINDOW AND DOOR LOCK/UNLOCK SWITCH RH17</p> <p style="padding-left: 20px;">Reference Value17</p> <p>WIRING DIAGRAM19</p> <p>POWER WINDOW SYSTEM19</p> <p style="padding-left: 20px;">Wiring Diagram19</p> <p>BASIC INSPECTION28</p> <p>DIAGNOSIS AND REPAIR WORKFLOW28</p> <p style="padding-left: 20px;">Work Flow28</p> <p>ADDITIONAL SERVICE WHEN REMOVING BATTERY NEGATIVE TERMINAL30</p> <p style="padding-left: 20px;">Description30</p> <p style="padding-left: 20px;">Work Procedure30</p> <p>ADDITIONAL SERVICE WHEN REPLACING CONTROL UNIT31</p> <p style="padding-left: 20px;">Description31</p> <p style="padding-left: 20px;">Work Procedure31</p> <p>SYSTEM INITIALIZATION32</p> <p style="padding-left: 20px;">Description32</p> <p style="padding-left: 20px;">Work Procedure32</p> <p>CHECK ANTI-PINCH FUNCTION33</p> <p style="padding-left: 20px;">Description33</p> <p style="padding-left: 20px;">Work Procedure33</p> <p>DTC/CIRCUIT DIAGNOSIS34</p> <p>POWER SUPPLY AND GROUND CIRCUIT34</p> <p>BCM34</p> <p style="padding-left: 20px;">BCM : Diagnosis Procedure34</p>
--	--



POWER WINDOW MAIN SWITCH	34	FRONT POWER WINDOW SWITCH : Diagnosis Procedure	52
POWER WINDOW MAIN SWITCH : Diagnosis Procedure	34		
FRONT POWER WINDOW SWITCH (PASSENGER SIDE)	35	SYMPTOM DIAGNOSIS	54
FRONT POWER WINDOW SWITCH (PASSENGER SIDE) : Diagnosis Procedure	36	POWER WINDOWS DO NOT OPERATE WITH POWER WINDOW MAIN SWITCH	54
		Diagnosis Procedure	54
REAR POWER WINDOW SWITCH	36	DRIVER SIDE POWER WINDOW ALONE DOES NOT OPERATE	55
REAR POWER WINDOW SWITCH : Diagnosis Procedure	36	Diagnosis Procedure	55
POWER WINDOW MOTOR	38	FRONT PASSENGER SIDE POWER WINDOW DOES NOT OPERATE	56
DRIVER SIDE	38	WHEN POWER WINDOW MAIN SWITCH IS OPERATED	56
DRIVER SIDE : Component Function Check	38	WHEN POWER WINDOW MAIN SWITCH IS OPERATED : Diagnosis Procedure	56
DRIVER SIDE : Diagnosis Procedure	38		
PASSENGER SIDE	39	WHEN FRONT POWER WINDOW SWITCH (PASSENGER SIDE) IS OPERATED	56
PASSENGER SIDE : Component Function Check	39	WHEN FRONT POWER WINDOW SWITCH (PASSENGER SIDE) IS OPERATED : Diagnosis Procedure	56
PASSENGER SIDE : Diagnosis Procedure	39		
REAR LH	40	WHEN BOTH POWER WINDOW MAIN SWITCH AND FRONT POWER WINDOW SWITCH ARE OPERATED	56
REAR LH : Component Function Check	40	WHEN BOTH POWER WINDOW MAIN SWITCH AND FRONT POWER WINDOW SWITCH ARE OPERATED : Diagnosis Procedure	56
REAR LH : Diagnosis Procedure	40		
REAR RH	41	REAR LH SIDE POWER WINDOW ALONE DOES NOT OPERATE	57
REAR RH : Component Function Check	41	WHEN POWER WINDOW MAIN SWITCH IS OPERATED	57
REAR RH : Diagnosis Procedure	41	WHEN POWER WINDOW MAIN SWITCH IS OPERATED : Diagnosis Procedure	57
ENCODER	43		
DRIVER SIDE	43	WHEN REAR POWER WINDOW SWITCH LH IS OPERATED	57
DRIVER SIDE : Component Function Check	43	WHEN REAR POWER WINDOW SWITCH LH IS OPERATED : Diagnosis Procedure	57
DRIVER SIDE : Diagnosis Procedure	43		
PASSENGER SIDE	45	WHEN BOTH POWER WINDOW MAIN SWITCH AND REAR POWER WINDOW SWITCH LH ARE OPERATED	57
PASSENGER SIDE : Component Function Check	45	WHEN BOTH POWER WINDOW MAIN SWITCH AND REAR POWER WINDOW SWITCH LH ARE OPERATED : Diagnosis Procedure	57
PASSENGER SIDE : Diagnosis Procedure	45		
DOOR KEY CYLINDER SWITCH	48	REAR RH SIDE POWER WINDOW ALONE DOES NOT OPERATE	58
Component Function Check	48	WHEN POWER WINDOW MAIN SWITCH IS OPERATED	58
Diagnosis Procedure	48	WHEN POWER WINDOW MAIN SWITCH IS OPERATED : Diagnosis Procedure	58
Component Inspection	49		
POWER WINDOW SERIAL LINK	50		
POWER WINDOW MAIN SWITCH	50		
POWER WINDOW MAIN SWITCH : Description	50		
POWER WINDOW MAIN SWITCH : Component Function Check	50		
POWER WINDOW MAIN SWITCH : Diagnosis Procedure	50		
FRONT POWER WINDOW SWITCH	51		
FRONT POWER WINDOW SWITCH : Description	51		
FRONT POWER WINDOW SWITCH : Component Function Check	51		

WHEN REAR POWER WINDOW SWITCH RH IS OPERATED	58	Diagnosis Procedure	63	
WHEN REAR POWER WINDOW SWITCH RH IS OPERATED : Diagnosis Procedure	58			A
WHEN BOTH POWER WINDOW MAIN SWITCH AND REAR POWER WINDOW SWITCH RH ARE OPERATED	58	KEYLESS POWER WINDOW DOWN DOES NOT OPERATE	64	
WHEN BOTH POWER WINDOW MAIN SWITCH AND REAR POWER WINDOW SWITCH RH ARE OPERATED : Diagnosis Procedure	58	Diagnosis Procedure	64	B
AUTO OPERATION DOES NOT OPERATE BUT MANUAL OPERATE NORMALLY	59	POWER WINDOW LOCK SWITCH DOES NOT FUNCTION	65	
DRIVER SIDE	59	Diagnosis Procedure	65	C
DRIVER SIDE : Diagnosis Procedure	59	POWER WINDOW SWITCH DOES NOT ILLUMINATE	66	
PASSENGER SIDE	59	DRIVER SIDE	66	D
PASSENGER SIDE : Diagnosis Procedure	59	DRIVER SIDE : Diagnosis Procedure	66	E
REAR LH	59	PASSENGER SIDE	66	
REAR LH : Diagnosis Procedure	59	PASSENGER SIDE : Diagnosis Procedure	66	F
REAR RH	60	REAR LH	66	
REAR RH : Diagnosis Procedure	60	REAR LH : Diagnosis Procedure	66	G
ANTI-PINCH FUNCTION DOES NOT OPERATE	61	REAR RH	66	
Diagnosis Procedure	61	REAR RH : Diagnosis Procedure	66	H
POWER WINDOW RETAINED POWER FUNCTION DOES NOT OPERATE NORMALLY	62	REMOVAL AND INSTALLATION	67	
Diagnosis Procedure	62	MAIN POWER WINDOW AND DOOR LOCK/UNLOCK SWITCH	67	
DOOR KEY CYLINDER SWITCH DOES NOT OPERATE POWER WINDOWS	63	Removal and Installation	67	I
		POWER WINDOW AND DOOR LOCK/UNLOCK SWITCH RH	68	
		Removal and Installation	68	J
		REAR POWER WINDOW SWITCH	69	
		Removal and Installation	69	PWC

PRECAUTIONS

< PRECAUTION >

PRECAUTION

PRECAUTIONS

Precaution for Supplemental Restraint System (SRS) "AIR BAG" and "SEAT BELT PRE-TENSIONER"

INFOID:000000011564214

The Supplemental Restraint System such as "AIR BAG" and "SEAT BELT PRE-TENSIONER", used along with a front seat belt, helps to reduce the risk or severity of injury to the driver and front passenger for certain types of collision. Information necessary to service the system safely is included in the SR and SB section of this Service Manual.

WARNING:

- To avoid rendering the SRS inoperative, which could increase the risk of personal injury or death in the event of a collision which would result in air bag inflation, all maintenance must be performed by an authorized NISSAN/INFINITI dealer.
- Improper maintenance, including incorrect removal and installation of the SRS, can lead to personal injury caused by unintentional activation of the system. For removal of Spiral Cable and Air Bag Module, see the SR section.
- Do not use electrical test equipment on any circuit related to the SRS unless instructed to in this Service Manual. SRS wiring harnesses can be identified by yellow and/or orange harnesses or harness connectors.

PRECAUTIONS WHEN USING POWER TOOLS (AIR OR ELECTRIC) AND HAMMERS

WARNING:

- When working near the Airbag Diagnosis Sensor Unit or other Airbag System sensors with the Ignition ON or engine running, DO NOT use air or electric power tools or strike near the sensor(s) with a hammer. Heavy vibration could activate the sensor(s) and deploy the air bag(s), possibly causing serious injury.
- When using air or electric power tools or hammers, always switch the Ignition OFF, disconnect the battery and wait at least three minutes before performing any service.

Precaution for Work

INFOID:000000011564215

- When removing or disassembling each component, be careful not to damage or deform it. If a component may be subject to interference, be sure to protect it with a shop cloth.
- When removing (disengaging) components with a screwdriver or similar tool, be sure to wrap the component with a shop cloth or vinyl tape to protect it.
- Protect the removed parts with a shop cloth and prevent them from being dropped.
- Replace a deformed or damaged clip.
- If a part is specified as a non-reusable part, always replace it with a new one.
- Be sure to tighten bolts and nuts securely to the specified torque.
- After installation is complete, be sure to check that each part works properly.
- Follow the steps below to clean components:
 - Water soluble dirt:
 - Dip a soft cloth into lukewarm water, wring the water out of the cloth and wipe the dirty area.
 - Then rub with a soft, dry cloth.
 - Oily dirt:
 - Dip a soft cloth into lukewarm water with mild detergent (concentration: within 2 to 3%) and wipe the dirty area.
 - Then dip a cloth into fresh water, wring the water out of the cloth and wipe the detergent off.
 - Then rub with a soft, dry cloth.
 - Do not use organic solvent such as thinner, benzene, alcohol or gasoline.
 - For genuine leather seats, use a genuine leather seat cleaner.

PREPARATION

< PREPARATION >

PREPARATION

PREPARATION

Special Service Tool

INFOID:000000011564212

The actual shape of the tools may differ from those illustrated here.

Tool number (TechMate No.) Tool name	Description
— (J-46534) Trim Tool Set	Removing trim components

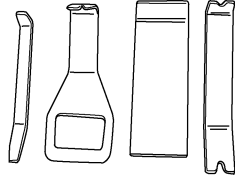

AWJIA0483ZZ

A
B
C
D
E
F
G
H
I
J
L
M
N
O
P

PWC

COMPONENT PARTS

< SYSTEM DESCRIPTION >

SYSTEM DESCRIPTION

COMPONENT PARTS

Component Parts Location

INFOID:000000011504303

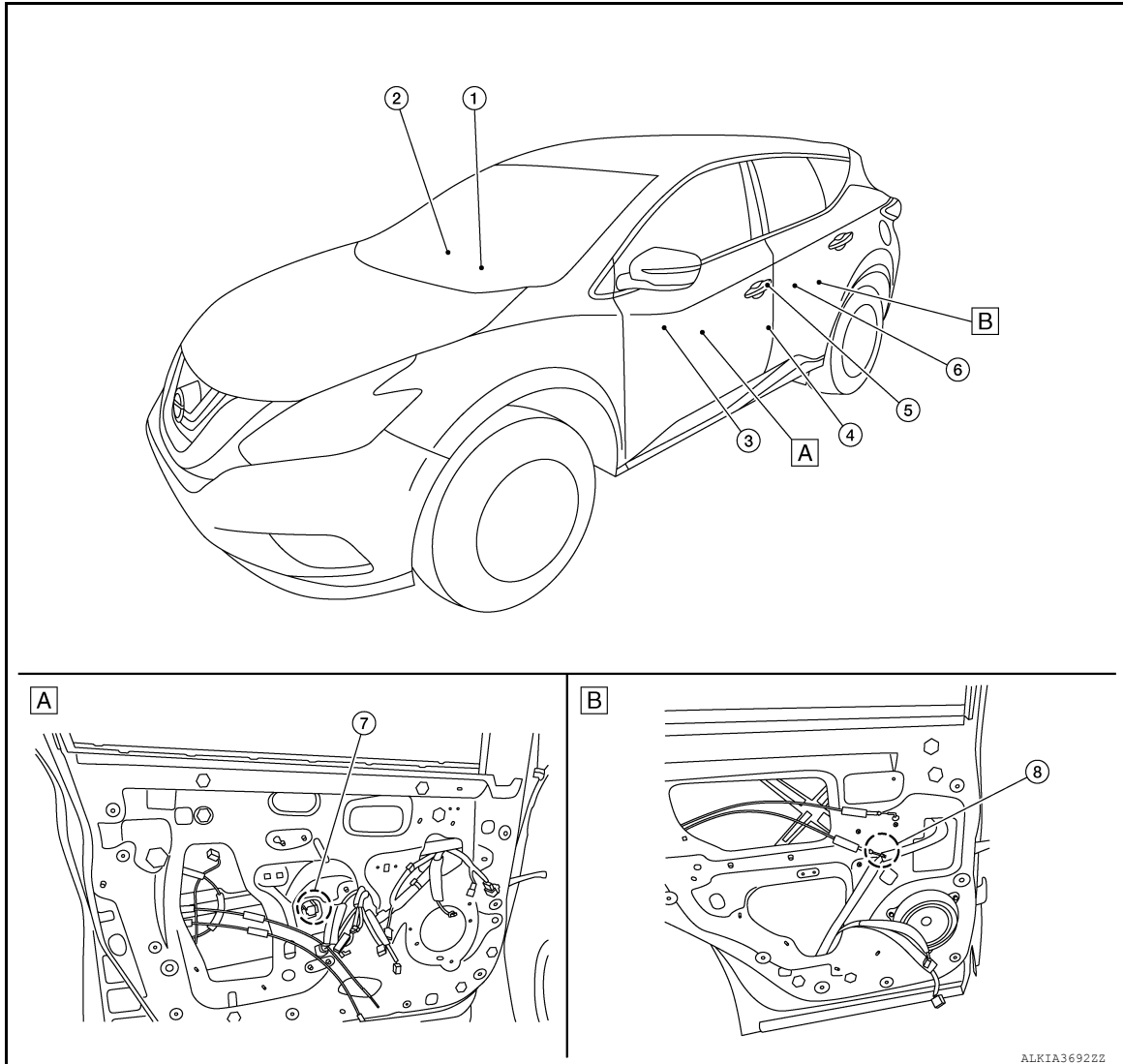

A. View with front door finisher removed B. View with rear door finisher removed

No.	Part	Function
1.	BCM	<ul style="list-style-type: none"> Supplies power to the window switches. Controls retained power. Refer to BCS-4, "BODY CONTROL SYSTEM : Component Parts Location" for detailed installation location.
2.	Power window and door lock/unlock switch RH	Refer to PWC-7, "Power Window and Door Lock/Unlock Switch RH"
3.	Main power window and door lock/unlock switch	Refer to PWC-7, "Main Power Window and Door Lock/Unlock Switch"
4.	Front door switch LH	Detects door open/close condition and transmits to BCM. Refer to DLK-22, "Front Door Switch" .
5.	Front door lock assembly LH (key cylinder switch)	Transmits operation condition of door key cylinder switch to main power window and door lock/unlock switch.
6.	Rear power window switch LH	Refer to PWC-7, "Rear Power Window Switch"

COMPONENT PARTS

< SYSTEM DESCRIPTION >

No.	Part	Function
7.	Front power window motor LH	Refer to PWC-7, "Power Window Motor"
8.	Rear power window motor LH	Refer to PWC-7, "Power Window Motor"

Main Power Window and Door Lock/Unlock Switch

INFOID:000000011504304

- Main power window and door lock/unlock switch controls all power windows.
- Main power window and door lock/unlock switch integrates UP/DOWN switch, power window lock switch, and door lock/unlock switch.
- Main power window and door lock/unlock switch controls power window lock function, AUTO UP/DOWN function.
- Receives encoder pulse signal and then controls anti-pinch system.

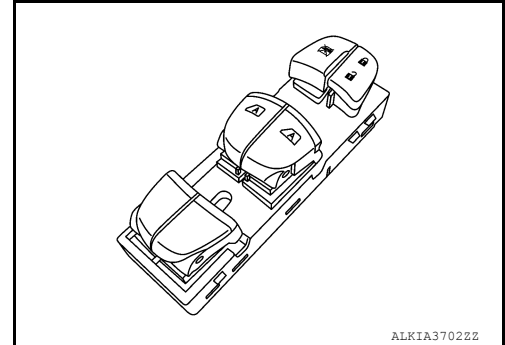

Power Window and Door Lock/Unlock Switch RH

INFOID:000000011504305

- Power window and door lock/unlock switch RH transmits AUTO UP/DOWN signal to front power window motor RH.
- Receives AUTO UP/DOWN signal from BCM and then transmits to front power window motor RH.
- Receives encoder pulse signal and then controls anti-pinch system.

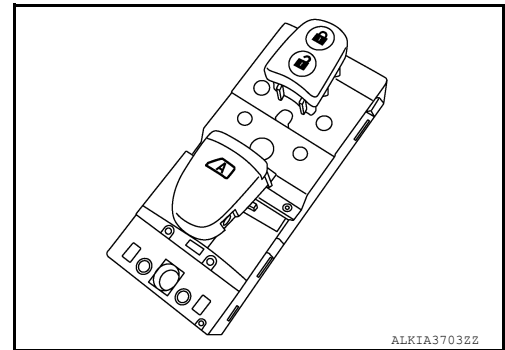

Rear Power Window Switch

INFOID:000000011504306

- Each power window switch transmits UP/DOWN signal to each motor.
- Each power window switch transmits UP/DOWN signal from main power window and door lock/unlock switch to each motor.

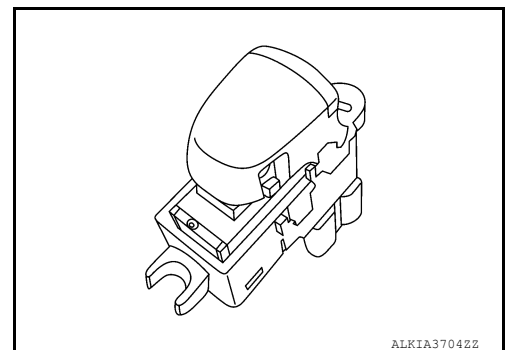

Power Window Motor

INFOID:000000011504307

- Integrates the encoder for front power windows.
- Starts operation according to signals from each power window switch.
- Transmits each power window motor rotation as a pulse signal to each power window switch.

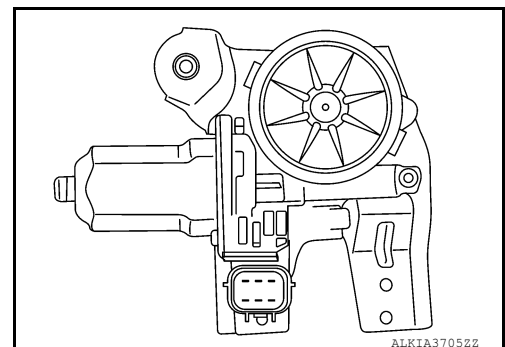

A
B
C
D
E
F
G
H
I
J
PWC
L
M
N
O
P

SYSTEM

< SYSTEM DESCRIPTION >

SYSTEM

System Description

INFOID:000000011218347

SYSTEM DIAGRAM

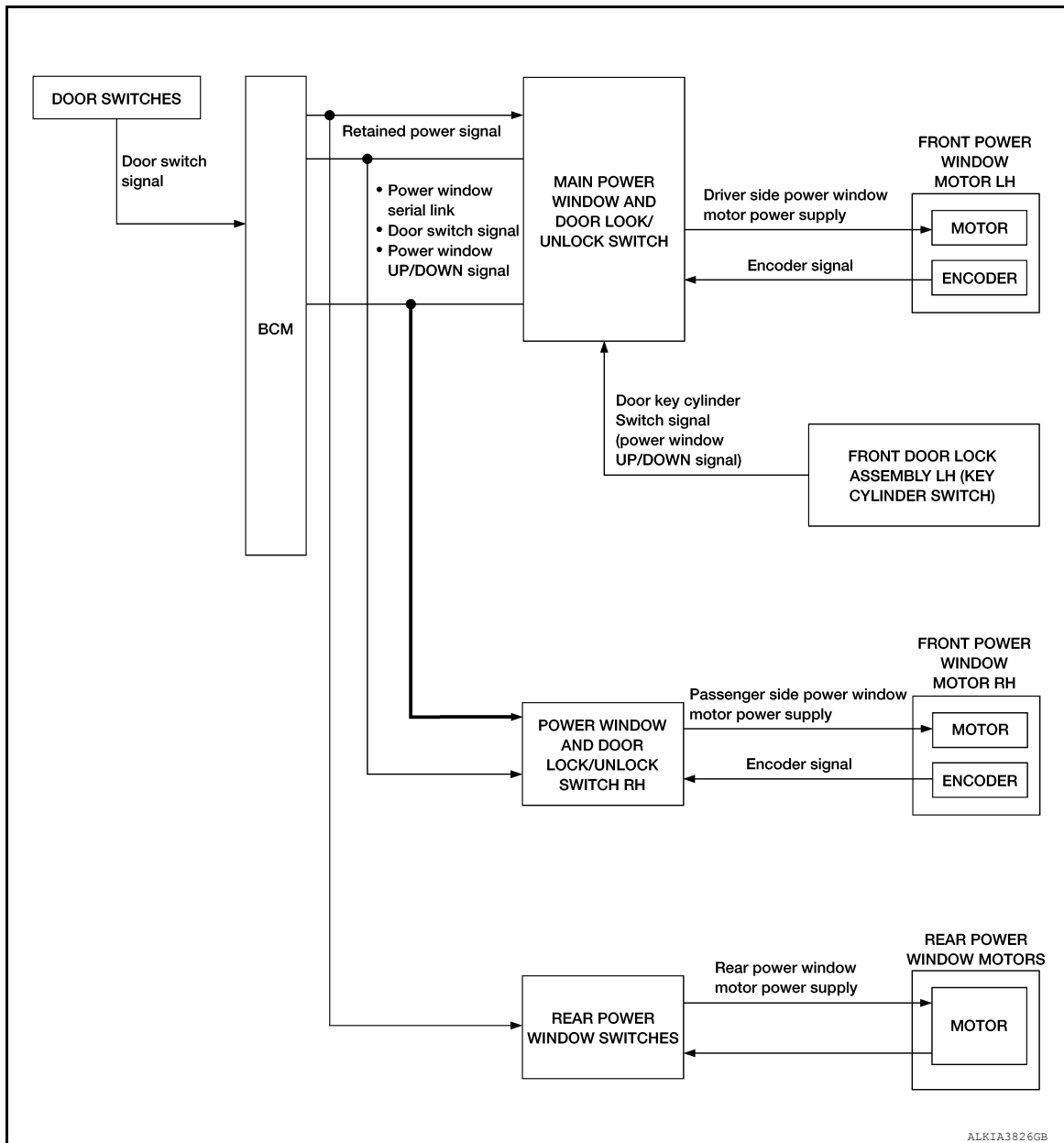

POWER WINDOW OPERATION

- Power window system is activated by the power window switches when the ignition switch is in the ON position or during the retained power operation after ignition switch turns OFF.
- Main power window and door lock/unlock switch can open/close door glass.
- Front and rear power window switches can open/close the corresponding door glass.
- Power window lock switch can lock all power windows other than driver front.
- Front power windows open when pressing Intelligent Key unlock button for 3 seconds.
- If door glass receives resistance that is more than the specified value and the power window is in the AUTO-UP operation, power window will move in the reverse direction (Anti-Pinch Function).

POWER WINDOW AUTO-OPERATION

- AUTO-UP/DOWN operation can be performed when each power window motor turns to AUTO.
- Encoder continues detecting the movement of power window motor and output the encoder pulse signal to power window switch while power window motor is operating.

SYSTEM

< SYSTEM DESCRIPTION >

- Power window switch reads the changes of encoder signal and stops AUTO operation when door glass is at fully opened/closed position. A
- Power window motor is operable in case encoder is malfunctioning. B
- AUTO function does not operate if encoder is malfunctioning. C

POWER WINDOW SERIAL LINK

Main power window and door lock/unlock switch, power window and door lock/unlock switch RH and BCM transmit and receive the signal by power window serial link.

The signal mentioned below is transmitted from BCM to main power window and door lock/unlock switch, power window and door lock/unlock switch RH. D

- Keyless power window down signal. E
- Door switch signal.
The signal mentioned below is transmitted from power window main switch to front power window switch (passenger side). F
- Front passenger side door window operation signal.
- Retained power operation signal.

RETAINED POWER OPERATION

- Retained power operation is an additional power supply function that enables the power window system to operate for 45 seconds even after the ignition switch is turned OFF. G

Retained Power Function Cancel Conditions:

- Front door CLOSE (door switch OFF)→OPEN (door switch ON). H
- When ignition switch is ON again. I
- When timer time passes. (45 seconds) J

POWER WINDOW LOCK FUNCTION

Ground circuit inside main power window and door lock/unlock switch shuts off when power window lock switch is ON. This inhibits power window switch operation except with the main power window and door lock/unlock switch. K

ANTI-PINCH OPERATION

- Pinch foreign material in the door glass during Auto-Up operation, and it is the anti-pinch that lowers the door glass 150 mm (5.9 in) or 2 seconds when detected. L
- Encoder continues detecting the movement of power window motor and transmits to the power window switch as the encoder pulse signal while power window motor is operating. M
- Resistance is applied to the power window motor rotation that changes the frequency of encoder pulse signal if foreign material is trapped in the door glass. N
- Power window switch controls to lower the door glass for 150 mm (5.9 in) or 2 seconds after it detects encoder pulse signal frequency change. O

Operation Condition

When front door glass AUTO-UP operation is performed (anti-pinch function does not operate just before the door glass closes and is fully closed)

NOTE:

Depending on environment and driving conditions, if a similar impact or load is applied to the door glass, it may lower. P

DOOR KEY CYLINDER SWITCH OPERATION

Hold the door key cylinder to the LOCK or UNLOCK direction for 1 second or more to OPEN or CLOSE front power windows when ignition switch is OFF. In addition, it stops when key position is moved to N (NEUTRAL) when operating. Q

Operation Condition

- Ignition switch OFF. R
- Hold door key cylinder to LOCK position for 1 second or more to perform CLOSE operation of the door glass.
- Hold door key cylinder to UNLOCK position for 1 second or more to perform OPEN operation of the door glass.

KEYLESS POWER WINDOW DOWN FUNCTION

Front power windows open when the unlock button on Intelligent Key is activated and pressed for more than 3 seconds with the ignition switch OFF. The windows keep opening if the unlock button is continuously pressed. The power window opening stops when the following operations are performed: S

SYSTEM

< SYSTEM DESCRIPTION >

- When the unlock button is pressed for more than 15 seconds.
- When the ignition switch is turned ON while the power window opening is operated.
- When the unlock button is released.

While retained power operation activate, keyless power window down function cannot be operated.

Fail-safe

INFOID:000000011218348

FAIL-SAFE CONTROL

Switches to fail-safe control when malfunction is detected in encoder signal that detects up/down speed and direction of door glass. Switches to fail-safe control when an error beyond the regulation value is detected between the fully closed position and the actual position of the glass.

Malfunction	Malfunction condition
Pulse sensor malfunction	When only one side of pulse signal is being detected for more than the specified value.
Both pulse sensors malfunction	When both pulse signals have not been detected for more than the specified value during glass open/close operation.
Pulse direction malfunction	When the pulse signal that is detected during glass open/close operation detects the opposite condition of power window motor operating direction.
Glass recognition position malfunction 1	When it detects the error between glass fully closed position in power window switch memory and actual fully closed position during glass open/close operation is more than the specified value.
Glass recognition position malfunction 2	When it detects pulse count more that the value of glass full stroke during glass open/close operation.
Malfunction of not yet updated closed position of glass	When glass open/close operation is continuously performed without fully closing more that the specified value (approximately 10 strokes).

It changes to condition before initialization and the following functions do not operate when switched to fail-safe control:

- Auto-up operation
- Anti-pinch function
- Retained power function

Perform initial operation to recover when switched to fail-safe mode. However, it switches back to fail-safe control when malfunction is found in power window switch or in motor.

DIAGNOSIS SYSTEM (BCM)

< SYSTEM DESCRIPTION >

DIAGNOSIS SYSTEM (BCM)

COMMON ITEM

COMMON ITEM : CONSULT Function (BCM - COMMON ITEM)

INFOID:0000000011508753

APPLICATION ITEM

CONSULT performs the following functions via CAN communication with BCM.

Direct Diagnostic Mode	Description
ECU Identification	The BCM part number is displayed.
Self Diagnostic Result	The BCM self diagnostic results are displayed.
Data Monitor	The BCM input/output data is displayed in real time.
Active Test	The BCM activates outputs to test components.
Work support	The settings for BCM functions can be changed.
Configuration	<ul style="list-style-type: none"> • The vehicle specification can be read and saved. • The vehicle specification can be written when replacing BCM.
CAN Diag Support Mntr	The result of transmit/receive diagnosis of CAN communication is displayed.

SYSTEM APPLICATION

BCM can perform the following functions:

System	Sub System	Direct Diagnostic Mode						
		ECU Identification	Self Diagnostic Result	Data Monitor	Active Test	Work support	Configuration	CAN Diag Support Mntr
Door lock	DOOR LOCK		×	×	×	×		
Rear window defogger	REAR DEFOGGER			×	×	×		
Warning chime	BUZZER			×	×			
Interior room lamp timer	INT LAMP			×	×	×		
Exterior lamp	HEADLAMP			×	×	×		
Wiper and washer	WIPER			×	×	×		
Turn signal and hazard warning lamps	FLASHER			×	×	×		
Air conditioner	AIR CONDITIONER			×				
Intelligent Key system	INTELLIGENT KEY		×	×	×	×		
Combination switch	COMB SW			×				
BCM	BCM	×	×			×	×	×
Immobilizer	IMMU		×	×	×			
Interior room lamp battery saver	BATTERY SAVER			×	×			
Back door open	TRUNK			×				
Vehicle security system	THEFT ALM			×	×	×		
RAP system	RETAINED PWR			×				
Signal buffer system	SIGNAL BUFFER			×	×			
TPMS	AIR PRESSURE MONITOR		×	×	×			

FREEZE FRAME DATA (FFD)

DIAGNOSIS SYSTEM (BCM)

< SYSTEM DESCRIPTION >

The BCM records the following vehicle condition at the time a particular DTC is detected, and displays it on CONSULT.

CONSULT screen item	Indication/Unit	Description
Vehicle Speed	km/h	Vehicle speed at the moment a particular DTC is detected
Odo/Trip Meter	km	Total mileage (Odometer value) at the moment a particular DTC is detected
Vehicle Condition	SLEEP>LOCK	While turning BCM status from low power consumption mode to normal mode (Power supply position is "LOCK"*).
	SLEEP>OFF	While turning BCM status from low power consumption mode to normal mode (Power supply position is "OFF".)
	LOCK>ACC	While turning power supply position from "LOCK"*to "ACC"
	ACC>ON	While turning power supply position from "ACC" to "IGN"
	RUN>ACC	While turning power supply position from "RUN" to "ACC" (Vehicle is stopped and selector lever is in P position.)
	CRANK>RUN	While turning power supply position from "CRANKING" to "RUN" (From cranking up the engine to run it)
	RUN>URGENT	While turning power supply position from "RUN" to "ACC" (Emergency stop operation)
	ACC>OFF	While turning power supply position from "ACC" to "OFF"
	OFF>LOCK	While turning power supply position from "OFF" to "LOCK"*
	OFF>ACC	While turning power supply position from "OFF" to "ACC"
	ON>CRANK	While turning power supply position from "IGN" to "CRANKING"
	OFF>SLEEP	While turning BCM status from normal mode (Power supply position is "OFF".) to low power consumption mode
	LOCK>SLEEP	While turning BCM status from normal mode (Power supply position is "LOCK"*.) to low power consumption mode
	LOCK	Power supply position is "LOCK" (Ignition switch OFF)*
	OFF	Power supply position is "OFF" (Ignition switch OFF)
	ACC	Power supply position is "ACC" (Ignition switch ACC)
	ON	Power supply position is "IGN" (Ignition switch ON with engine stopped)
	ENGINE RUN	Power supply position is "RUN" (Ignition switch ON with engine running)
CRANKING	Power supply position is "CRANKING" (At engine cranking)	
IGN Counter	0 - 39	<p>The number of times that ignition switch is turned ON after DTC is detected</p> <ul style="list-style-type: none"> • The number is 0 when a malfunction is detected now. • The number increases like 1 → 2 → 3...38 → 39 after returning to the normal condition whenever ignition is switched OFF → ON. • The number is fixed to 39 until the self-diagnosis results are erased if it is over 39.

NOTE:

*: Power supply position shifts to "LOCK" from "OFF", when ignition switch is in the OFF position, selector lever is in the P position, and any of the following conditions are met:

- Closing door
- Opening door
- Door is locked using door request switch
- Door is locked using Intelligent Key

The power supply position shifts to "ACC" when the push-button ignition switch (push switch) is pushed at "LOCK".

RETAINED PWR

RETAINED PWR : CONSULT Function (BCM - RETAINED PWR)

INFOID:0000000011508754

DATA MONITOR

DIAGNOSIS SYSTEM (BCM)

< SYSTEM DESCRIPTION >

Monitor Item [Unit]	Description
DOOR SW-DR [On/Off]	Indicates condition of front door switch LH.
DOOR SW-AS [On/Off]	Indicates condition of front door switch RH.

A

B

C

D

E

F

G

H

I

J

PWC

L

M

N

O

P

BCM (BODY CONTROL MODULE)

< ECU DIAGNOSIS INFORMATION >

ECU DIAGNOSIS INFORMATION

BCM (BODY CONTROL MODULE)

List of ECU Reference

INFOID:000000011218351

ECU	Reference
BCM	BCS-30. "Reference Value"
	BCS-50. "Fail Safe"
	BCS-51. "DTC Inspection Priority Chart"
	BCS-52. "DTC Index"

MAIN POWER WINDOW AND DOOR LOCK/UNLOCK SWITCH

< ECU DIAGNOSIS INFORMATION >

MAIN POWER WINDOW AND DOOR LOCK/UNLOCK SWITCH

Reference Value

INFOID:000000011218352

TERMINAL LAYOUT

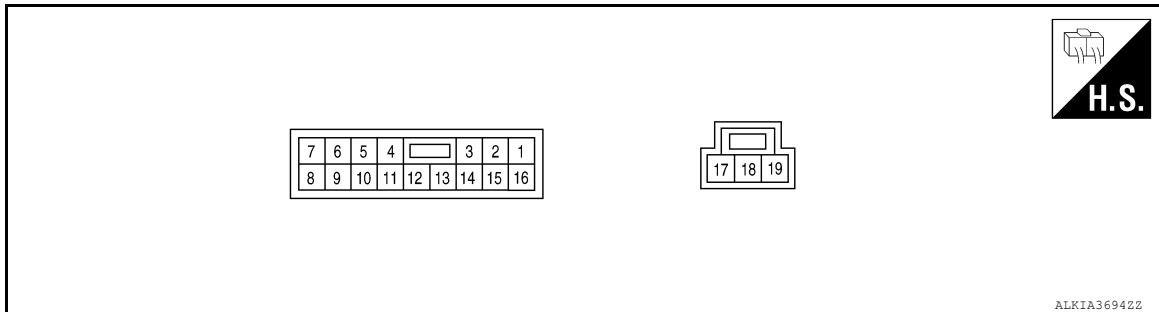

PHYSICAL VALUES

Terminal No. (wire color)		Description		Condition	Voltage (Approx.)
+	-	Signal name	Input/ Output		
1 (B)	Ground	Ground	Output	—	0
3 (BR)	Ground	Door lock actuator signal	Output	—	—
4 (R)	12 (Y)	Encoder pulse signal 2	Input	When power window motor operates	 <small>JMKIA0070GB</small>
5 (Y)	12 (Y)	Encoder pulse signal 1	Input	When power window motor operates	 <small>JMKIA0070GB</small>
6 (L)	Ground	Rear power window motor RH DOWN signal.	Output	When rear power window switch RH is operated DOWN	Battery voltage
7 (V)	Ground	Rear power window motor RH UP signal.	Output	When rear power window switch RH is operated UP	Battery voltage
8 (LG)	Ground	Rear power window motor LH DOWN signal.	Output	When rear power window switch LH is operated DOWN	Battery voltage
9 (SB)	Ground	Rear power window motor LH UP signal.	Output	When rear power window switch LH is operated UP	Battery voltage
10 (BR)	Ground	Ignition switch power supply	Input	Ignition switch ON	Battery voltage
				Other than above	0

A
B
C
D
E
F
G
H
I
J
L
M
N
O
P

PWC

MAIN POWER WINDOW AND DOOR LOCK/UNLOCK SWITCH

< ECU DIAGNOSIS INFORMATION >

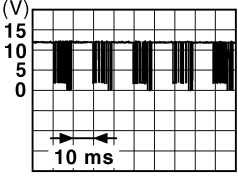
Terminal No. (wire color)		Description		Condition	Voltage (Approx.)
+	-	Signal name	Input/ Output		
11 (Y/L)	Ground	Power window serial link	Input/ Output	IGN SW ON or power window operating.	 <p style="text-align: right; font-size: small;">JPMIA0013GB</p>
12 (Y)	Ground	Encoder ground	—	—	0
14 (P)	Ground	Encoder power supply	Output	When ignition is ON or power window timer operates.	Battery voltage
15 (L/W)	Ground	Door lock actuator signal	Output	—	Battery voltage
17 (G)	19 (Y)	Main power window and door lock/unlock switch UP signal	Output	When main power window and door lock/unlock switch is operated UP	Battery voltage
18 (Y)	Ground	Battery power supply	Input	—	Battery voltage
19 (Y)	17 (G)	Main power window and door lock/unlock switch UP signal	Output	When main power window and door lock/unlock switch is operated DOWN	Battery voltage

POWER WINDOW AND DOOR LOCK/UNLOCK SWITCH RH

< ECU DIAGNOSIS INFORMATION >

POWER WINDOW AND DOOR LOCK/UNLOCK SWITCH RH

Reference Value

INFOID:000000011218353

TERMINAL LAYOUT

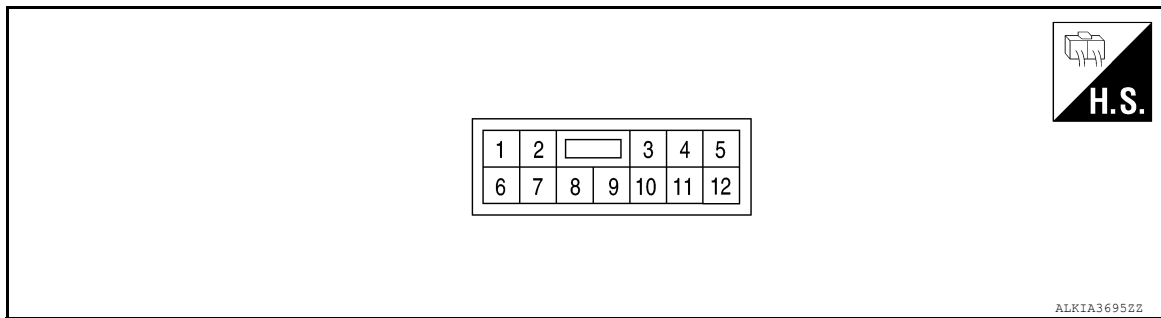

PHYSICAL VALUES

Terminal No. (wire color)		Description		Condition	Voltage (Approx.)
+	-	Signal name	Input/ Output		
3 (Y/L)	Ground	Power window serial link	Input/ Output	IGN SW ON or power window operating	<p>JPMIA0013GB</p>
4 (B)	Ground	Encoder ground	—	—	—
5 (L/W)	Ground	Encoder power supply	Output	When ignition switch is ON or power window timer operates.	Battery voltage
7 (B)	Ground	Ground	—	—	—
8 (Y)	Ground	Battery power supply	Input	—	Battery voltage
9 (P)	4 (B)	Encoder pulse signal 1	Input	When power window motor operates	<p>JMKIA0070GB</p>
10 (R)	4 (B)	Encoder pulse signal 2	Input	When power window motor operates	<p>JMKIA0070GB</p>

A
B
C
D
E
F
G
H
I
J
L
M
N
O
P

PWC

POWER WINDOW AND DOOR LOCK/UNLOCK SWITCH RH

< ECU DIAGNOSIS INFORMATION >

Terminal No. (wire color)		Description		Condition	Voltage (Approx.)
+	-	Signal name	Input/ Output		
11 (G)	12 (G)	Assistant window switch UP signal	Output	When power window and door lock/unlock switch RH is oper- ated UP	Battery voltage
12 (G)	11 (G)	Assistant window switch DOWN signal	Output	When power window and door lock/unlock switch RH is oper- ated DOWN	Battery voltage

POWER WINDOW SYSTEM

< WIRING DIAGRAM >

WIRING DIAGRAM

POWER WINDOW SYSTEM

Wiring Diagram

INFOID:000000011218356

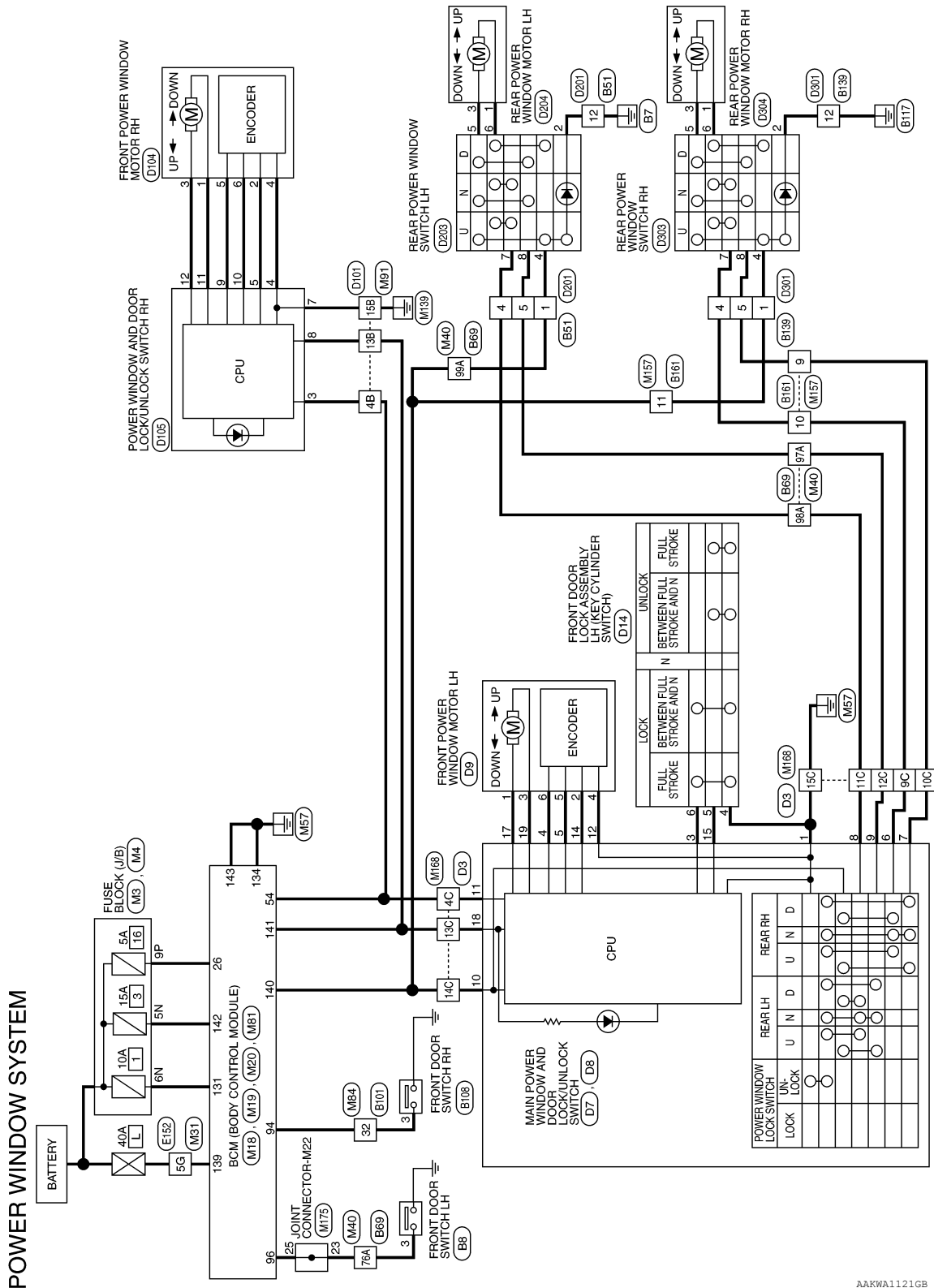

AAKWA1121GB

A
B
C
D
E
F
G
H
I
J
K
L
M
N
O
P



POWER WINDOW SYSTEM

< WIRING DIAGRAM >

POWER WINDOW SYSTEM CONNECTORS

Connector No.	M3
Connector Name	FUSE BLOCK (J/B)
Connector Color	WHITE



Connector No.	M4
Connector Name	FUSE BLOCK (J/B)
Connector Color	WHITE



Terminal No.	Color of Wire	Signal Name
5N	Y	-
6N	W	-

Terminal No.	Color of Wire	Signal Name
9P	L	-

Connector No.	M18
Connector Name	BCM (BODY CONTROL MODULE)
Connector Color	GREEN

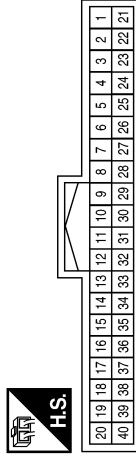

Terminal No.	Color of Wire	Signal Name
26	L	SHORTING INPUT

Connector No.	M19
Connector Name	BCM (BODY CONTROL MODULE)
Connector Color	BLACK



Terminal No.	Color of Wire	Signal Name
54	W	PW LIN

Connector No.	M20
Connector Name	BCM (BODY CONTROL MODULE)
Connector Color	GRAY

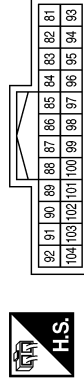

Terminal No.	Color of Wire	Signal Name
94	G	AS DOOR SW
96	BG	DR DOOR SW

Connector No.	M31
Connector Name	WIRE TO WIRE
Connector Color	WHITE

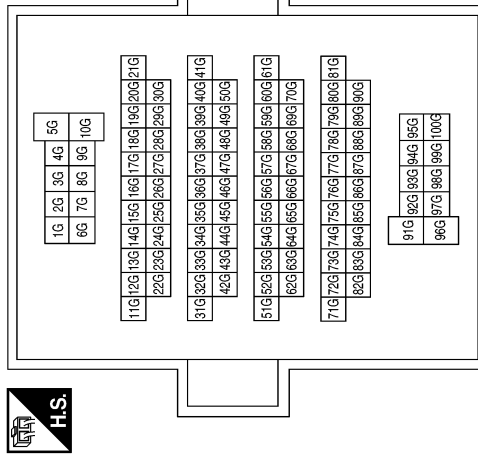

Terminal No.	Color of Wire	Signal Name
5G	L	-

AAKIA2664GB

POWER WINDOW SYSTEM

< WIRING DIAGRAM >

Connector No.	M40
Connector Name	WIRE TO WIRE
Connector Color	GRAY

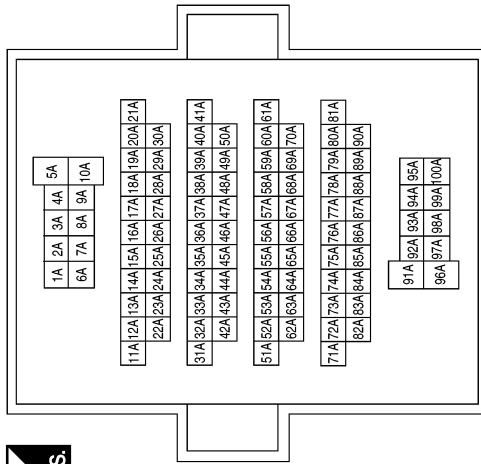

Terminal No.	Color of Wire	Signal Name
76A	BG	-
97A	SB	-
98A	LG	-
99A	BR	-

Connector No.	M81
Connector Name	BCM (BODY CONTROL MODULE)
Connector Color	WHITE

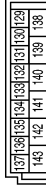

Terminal No.	Color of Wire	Signal Name
131	W	BAT BCM FUSE
134	GR	GND2
139	L	BAT POWER F/L
140	BR	P/W POWER SUPPLY IGN
141	Y	P/W POWER SUPPLY BAT
142	Y	BAT FRONT DOOR
143	GR	GND1

Connector No.	M84
Connector Name	WIRE TO WIRE
Connector Color	WHITE

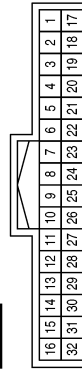

Terminal No.	Color of Wire	Signal Name
32	G	-

Connector No.	M91
Connector Name	WIRE TO WIRE
Connector Color	WHITE

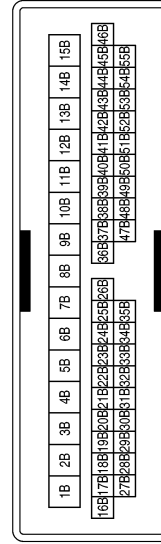

Terminal No.	Color of Wire	Signal Name
4B	W	-
13B	Y	-
15B	B	-

A
B
C
D
E
F
G
H
I
J
K
L
M
N
O
P

PWC

AAKIA2665GB

POWER WINDOW SYSTEM

< WIRING DIAGRAM >

Connector No.	M157
Connector Name	WIRE TO WIRE
Connector Color	WHITE

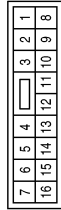

Terminal No.	Color of Wire	Signal Name
9	V	-
10	L	-
11	BR	-

Connector No.	M168
Connector Name	WIRE TO WIRE
Connector Color	WHITE

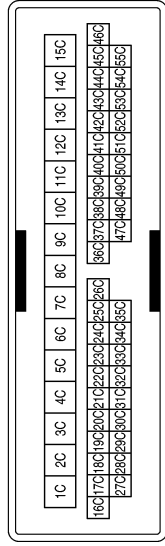

Terminal No.	Color of Wire	Signal Name
4C	W	-
9C	L	-
10C	V	-
11C	LG	-
12C	SB	-
13C	Y	-
14C	BR	-
15C	B	-

Connector No.	M175
Connector Name	JOINT CONNECTOR-M22
Connector Color	WHITE

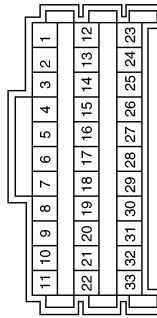

Terminal No.	Color of Wire	Signal Name
23	BG	-
25	BG	-

Connector No.	E152
Connector Name	WIRE TO WIRE
Connector Color	WHITE

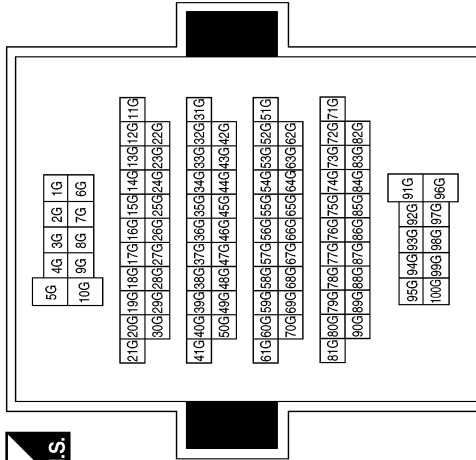

Terminal No.	Color of Wire	Signal Name
5G	P	-

POWER WINDOW SYSTEM

< WIRING DIAGRAM >

Connector No.	B8
Connector Name	FRONT DOOR SWITCH LH
Connector Color	WHITE

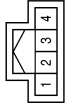

Terminal No.	Color of Wire	Signal Name
3	O	-

Connector No.	B51
Connector Name	WIRE TO WIRE
Connector Color	WHITE

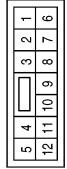

Terminal No.	Color of Wire	Signal Name
1	BR	-
4	Y	-
5	SB	-
12	B	-

Connector No.	B69
Connector Name	WIRE TO WIRE
Connector Color	GRAY

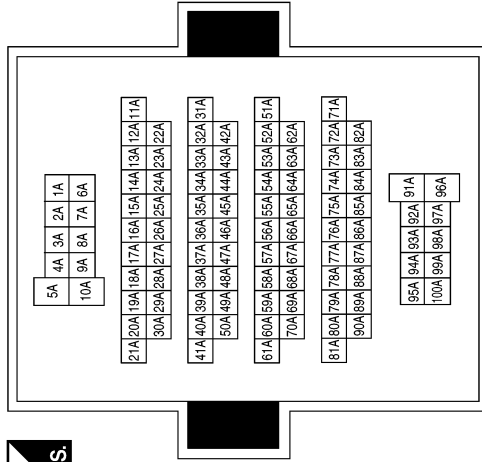

Terminal No.	Color of Wire	Signal Name
76A	O	-
97A	SB	-
98A	Y	-
99A	BR	-

Connector No.	B101
Connector Name	WIRE TO WIRE
Connector Color	WHITE

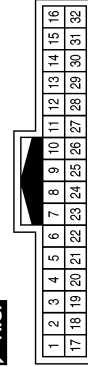

Terminal No.	Color of Wire	Signal Name
32	V	-

AAKIA2667GB

A
B
C
D
E
F
G
H
I
J
L
M
N
O
P

PWC

POWER WINDOW SYSTEM

< WIRING DIAGRAM >

Connector No.	B108
Connector Name	FRONT DOOR SWITCH RH
Connector Color	WHITE

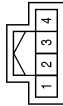

Terminal No.	Color of Wire	Signal Name
3	V	-

Connector No.	B139
Connector Name	WIRE TO WIRE
Connector Color	WHITE

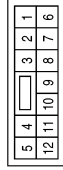

Terminal No.	Color of Wire	Signal Name
1	BR	-
4	Y	-
5	SB	-
12	B	-

Connector No.	B161
Connector Name	WIRE TO WIRE
Connector Color	WHITE

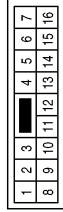

Terminal No.	Color of Wire	Signal Name
9	SB	-
10	Y	-
11	BR	-

Connector No.	D3
Connector Name	WIRE TO WIRE
Connector Color	WHITE

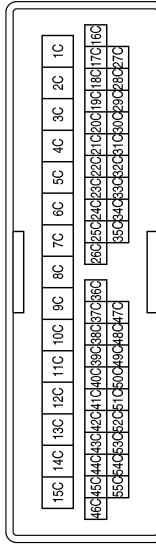

Terminal No.	Color of Wire	Signal Name
4C	Y/L	-
9C	L	-
10C	V	-
11C	LG	-
12C	SB	-
13C	Y	-
14C	BR	-
15C	B	-

Connector No.	D7
Connector Name	MAIN POWER WINDOW AND DOOR LOCK/UNLOCK SWITCH
Connector Color	WHITE

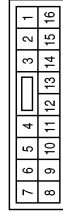

Terminal No.	Color of Wire	Signal Name
1	B	GND
2	-	-
3	BR	D LOCK ACTR DR
4	R	ENCODER SIG2
5	Y	ENCODER SIG1
6	L	RR DN
7	V	RR UP
8	LG	RL DN
9	SB	RL UP
10	BR	IGN
11	Y/L	COM
12	Y	ENCODER GND

Terminal No.	Color of Wire	Signal Name
13	-	-
14	P	ENCODER +
15	L/W	D LOCK ACTR DR
16	-	-

AAKIA2668GB

POWER WINDOW SYSTEM

< WIRING DIAGRAM >

Connector No.	D8
Connector Name	MAIN POWER WINDOW AND DOOR LOCK/UNLOCK SWITCH
Connector Color	WHITE



Terminal No.	Color of Wire	Signal Name
17	G	DR UP
18	Y	BAT
19	Y	DR DN

Connector No.	D9
Connector Name	FRONT POWER WINDOW MOTOR LH
Connector Color	GREEN



Terminal No.	Color of Wire	Signal Name
1	G	DR UP
2	P	VCC
3	Y	DR DN
4	Y	GND
5	Y	OUTPUT1
6	R	OUTPUT2

Connector No.	D14
Connector Name	FRONT DOOR LOCK ASSEMBLY LH
Connector Color	GRAY



Terminal No.	Color of Wire	Signal Name
4	B	-
5	LW	-
6	BR	-

Connector No.	D101
Connector Name	WIRE TO WIRE
Connector Color	WHITE

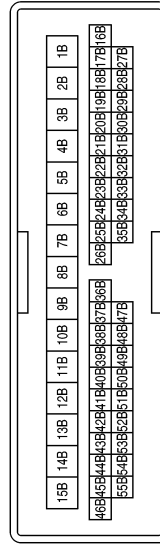

Terminal No.	Color of Wire	Signal Name
4B	Y/L	-
13B	Y	-
15B	B	-

Connector No.	D104
Connector Name	FRONT POWER WINDOW MOTOR RH
Connector Color	GREEN



Terminal No.	Color of Wire	Signal Name
1	G	AS UP
2	LW	VCC
3	G	AS DN
4	B	GND
5	P	OUTPUT1
6	R	OUTPUT2

AAKIA2669GB

A B C D E F G H I J L M N O P

PWC

POWER WINDOW SYSTEM

< WIRING DIAGRAM >

Connector No.	D201
Connector Name	WIRE TO WIRE
Connector Color	WHITE



1	2	3	4	5
6	7	8	9	10
11	12			

Terminal No.	Color of Wire	Signal Name
1	R/Y	-
4	Y	-
5	SB	-
12	B	-

Terminal No.	Color of Wire	Signal Name
6	-	-
7	B	GND
8	Y	BAT
9	P	ENCODER SIG1
10	R	ENCODER SIG2
11	G	AS UP
12	G	AS DN

Connector No.	D105
Connector Name	POWER WINDOW AND DOOR LOCK/UNLOCK SWITCH RH
Connector Color	WHITE



1	2	3	4	5
6	7	8	9	10
11	12			

Terminal No.	Color of Wire	Signal Name
1	-	-
2	-	-
3	Y/L	COM
4	B	ENCODER GND
5	L/W	ENCODER +

Connector No.	D301
Connector Name	WIRE TO WIRE
Connector Color	WHITE



1	2	3	4	5
6	7	8	9	10
11	12			

Terminal No.	Color of Wire	Signal Name
1	G/B	-
4	R/Y	-
5	SB	-
12	B	-

Connector No.	D204
Connector Name	REAR POWER WINDOW MOTOR LH
Connector Color	GREEN



3	2	1
6	5	4

Terminal No.	Color of Wire	Signal Name
1	LG	-
2	-	-
3	V	-
4	-	-
5	-	-
6	-	-

Connector No.	D203
Connector Name	REAR POWER WINDOW SWITCH LH
Connector Color	WHITE



3	2	1
8	7	6
5	4	

Terminal No.	Color of Wire	Signal Name
1	-	-
2	B	-
3	-	-
4	R/Y	-
5	V	-
6	LG	-
7	Y	-
8	SB	-

AAKIA2670GB

POWER WINDOW SYSTEM

< WIRING DIAGRAM >

Connector No.	D304
Connector Name	REAR POWER WINDOW MOTOR RH
Connector Color	GREEN



Terminal No.	Color of Wire	Signal Name
1	LG	-
2	-	-
3	V	-
4	-	-
5	-	-
6	-	-

Connector No.	D303
Connector Name	REAR POWER WINDOW SWITCH RH
Connector Color	WHITE

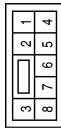

Terminal No.	Color of Wire	Signal Name
1	-	-
2	B	-
3	-	-
4	G/B	-
5	V	-
6	LG	-
7	R/Y	-
8	SB	-

A
B
C
D
E
F
G
H
I
J
L
M
N
O
P

PWC

AAKIA2671GB

DIAGNOSIS AND REPAIR WORKFLOW

< BASIC INSPECTION >

BASIC INSPECTION

DIAGNOSIS AND REPAIR WORKFLOW

Work Flow

INFOID:000000011504935

OVERALL SEQUENCE

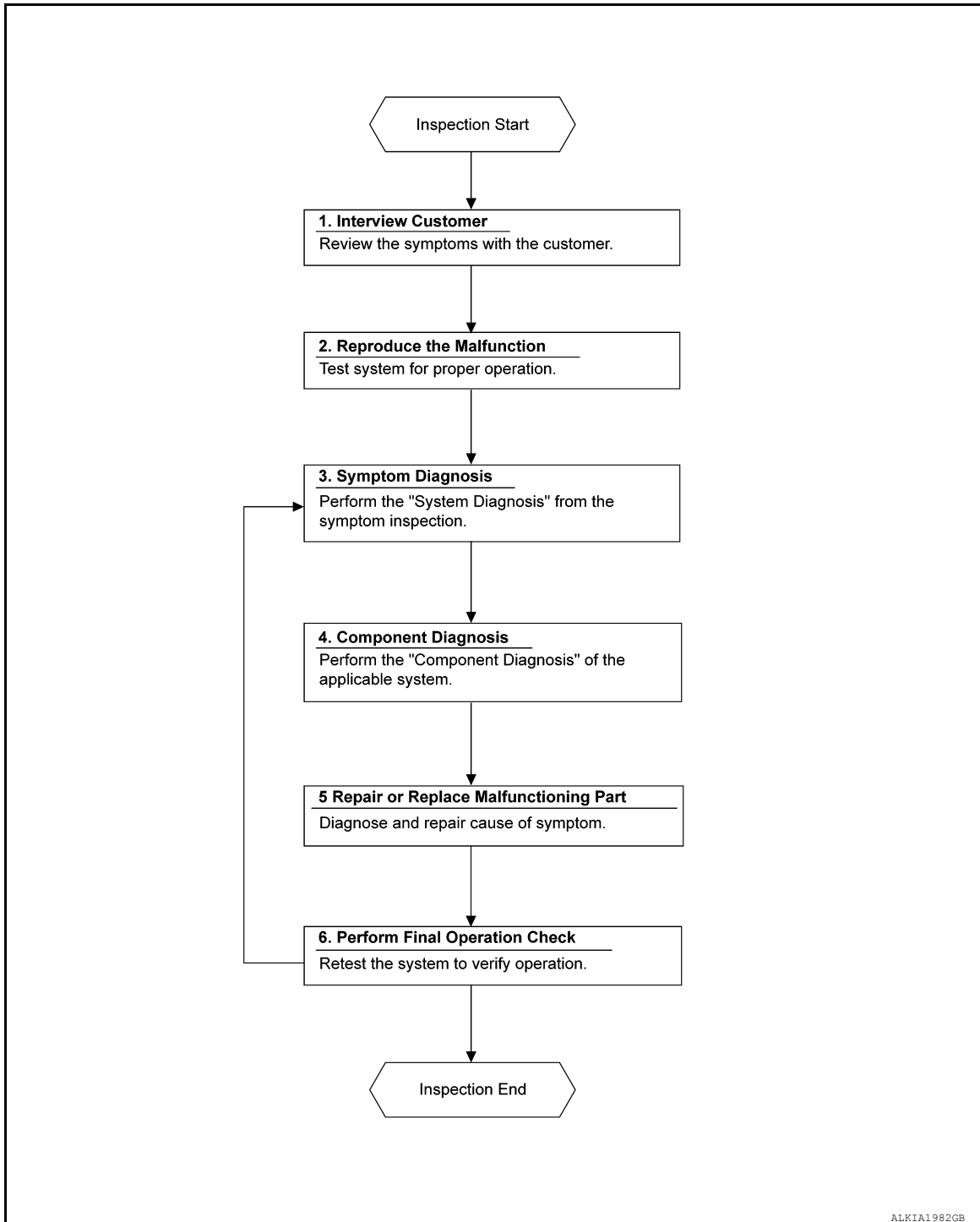

DETAILED FLOW

1. INTERVIEW CUSTOMER

Interview the customer to obtain as much information as possible about the conditions and environment under which the malfunction occurred.

DIAGNOSIS AND REPAIR WORKFLOW

< BASIC INSPECTION >

>> GO TO 2.

2. REPRODUCE THE MALFUNCTION

Reproduce the malfunction on the vehicle that the customer describes.
Inspect the relation of the symptoms and the condition when the symptoms occur.

>> GO TO 3.

3. SYMPTOM DIAGNOSIS

Use Symptom diagnosis from the symptom inspection result in step 2 and then identify where to start performing the diagnosis based on possible causes and symptoms.

>> GO TO 4.

4. COMPONENT DIAGNOSIS

Perform the diagnosis with Component diagnosis of the applicable system.

>> GO TO 5.

5. REPAIR OR REPLACE THE MALFUNCTIONING PART

Repair or replace the specified malfunctioning parts.

>> GO TO 6.

6. PERFORM FINAL OPERATIONAL CHECK

Check that malfunctions are not reproduced when obtaining the malfunction information from the customer, referring to the symptom inspection result in step 2.

Are the malfunctions corrected?

YES >> Inspection End.

NO >> GO TO 3.

A
B
C
D
E
F
G
H
I
J
L
M
N
O
P

PWC

ADDITIONAL SERVICE WHEN REMOVING BATTERY NEGATIVE TERMINAL

< BASIC INSPECTION >

ADDITIONAL SERVICE WHEN REMOVING BATTERY NEGATIVE TERMINAL

Description

INFOID:000000011218358

When the negative battery terminal is disconnected, the initialization is necessary for normal operation of power window system.

CAUTION:

The following specified operations can not be performed under the non-initialized condition:

- Auto-up operation
- Anti-pinch function

Work Procedure

INFOID:000000011218359

1.SYSTEM INITIALIZATION

Perform system initialization. Refer to [PWC-32. "Work Procedure"](#).

>> GO TO 2.

2.CHECK ANTI-PINCH FUNCTION

Check anti-pinch function. Refer to [PWC-33. "Work Procedure"](#).

>> Inspection End.

ADDITIONAL SERVICE WHEN REPLACING CONTROL UNIT

< BASIC INSPECTION >

ADDITIONAL SERVICE WHEN REPLACING CONTROL UNIT

Description

INFOID:000000011218360

When the negative battery terminal is disconnected, the initialization is necessary for normal operation of power window system.

CAUTION:

The following specified operations can not be performed under the non-initialized condition:

- Auto-up operation
- Anti-pinch function

Work Procedure

INFOID:000000011218361

1.SYSTEM INITIALIZATION

Perform system initialization. Refer to [PWC-32. "Work Procedure"](#).

>> GO TO 2.

2.CHECK ANTI-PINCH FUNCTION

Check anti-pinch function. Refer to [PWC-33. "Work Procedure"](#).

>> Inspection End.

A
B
C
D
E
F
G
H
I
J
L
M
N
O
P

PWC

SYSTEM INITIALIZATION

< BASIC INSPECTION >

SYSTEM INITIALIZATION

Description

INFOID:000000011218362

The initialization is necessary for normal operation of power window system If any of the following operations are performed:

- When control unit is replaced.
- Electric power supply to power window switch or motor is interrupted by blown fuse or disconnection and connection of the negative battery terminal.
- Removal and installation of regulator assembly.
- Power supply to the main power window and door lock/unlock switch or power window motor is cut off by the removal of battery terminal or if the battery fuse is blown.
- Disconnection and connection of main power window and door lock/unlock switch harness connector.
- Removal and installation of motor from regulator assembly.
- Operation of regulator assembly as an independent unit.
- Removal and installation of door glass.
- Removal and installation of door glass run.

The following specified operations can not be performed under the non-initialized condition:

- Auto-up operation
- Anti-pinch function

Work Procedure

INFOID:000000011218363

1.STEP 1

-
1. Turn ignition switch ON.
 2. Open the window not less than half way.
 3. Pull up on the power window switch to close the window completely. Continue to hold the power window switch up for 3 or more seconds.
 4. Check that AUTO-UP function operates normally.

>> GO TO 2.

2.STEP 2

Check anti-pinch function. Refer to [PWC-33. "Work Procedure"](#).

>> Inspection End.

CHECK ANTI-PINCH FUNCTION

< BASIC INSPECTION >

CHECK ANTI-PINCH FUNCTION

Description

INFOID:000000011218364

The initialization is necessary for normal operation of power window system. If any of the following operations are performed:

- When control unit is replaced.
- Electric power supply to power window switch or motor is interrupted by blown fuse or disconnection and connection of the negative battery terminal.
- Removal and installation of regulator assembly.
- Power supply to the main power window and door lock/unlock switch or power window motor is cut off by the removal of battery terminal or if the battery fuse is blown.
- Disconnection and connection of main power window and door lock/unlock switch harness connector.
- Removal and installation of motor from regulator assembly.
- Operation of regulator assembly as an independent unit.
- Removal and installation of door glass.
- Removal and installation of door glass run.

The following specified operations can not be performed under the non-initialized condition:

- Auto-up operation
- Anti-pinch function

Work Procedure

INFOID:000000011218365

1. CHECK ANTI-PINCH FUNCTION

- Fully open the door window.
- Place a piece of wood near fully closed position.
- Close door glass completely with AUTO-UP.
- Check the following conditions:
 - Check that glass lowers for approximately 150 mm (5.9 in) without pinching piece of wood and stops.
 - Check that glass does not rise when operating the main power window and door lock/unlock switch while lowering.

CAUTION:

- Perform initial setting when AUTO-UP operation or anti-pinch function does not operate normally.
- Check that AUTO-UP operates before inspection when system initialization is performed.
- Do not check with hands and other body parts because they may be pinched. Do not get pinched.

>> Inspection End.

A
B
C
D
E
F
G
H
I
J
L
M
N
O
P

PWC

POWER SUPPLY AND GROUND CIRCUIT

< DTC/CIRCUIT DIAGNOSIS >

DTC/CIRCUIT DIAGNOSIS

POWER SUPPLY AND GROUND CIRCUIT

BCM

BCM : Diagnosis Procedure

INFOID:000000011532794

Regarding Wiring Diagram information, refer to [BCS-55, "Wiring Diagram"](#).

1. CHECK FUSE AND FUSIBLE LINK

Check that the following fuse and fusible link are not blown.

Signal name	Fuse and fusible link No.
Fusible link battery power	L (40A)
BCM battery fuse	1 (10A)

Is the fuse or fusible link blown?

- YES >> Replace the blown fuse or fusible link after repairing the affected circuit.
NO >> GO TO 2.

2. CHECK POWER SUPPLY CIRCUIT

1. Disconnect BCM connector M81.
2. Check voltage between BCM connector M81 terminals 131, 139 and ground.

BCM		Ground	Voltage (Approx.)
Connector	Terminal		
M81	131	—	Battery voltage
	139		

Is the inspection result normal?

- YES >> GO TO 3.
NO >> Repair or replace harness or connectors.

3. CHECK GROUND CIRCUIT

Check continuity between BCM connector M81 terminals 134, 143 and ground.

BCM		Ground	Continuity
Connector	Terminal		
M81	134	—	Yes
	143		

Is the inspection result normal?

- YES >> Inspection End.
NO >> Repair or replace harness or connectors.

POWER WINDOW MAIN SWITCH

POWER WINDOW MAIN SWITCH : Diagnosis Procedure

INFOID:000000011218367

Regarding Wiring Diagram information, refer to [PWC-19, "Wiring Diagram"](#).

1. CHECK POWER SUPPLY

POWER SUPPLY AND GROUND CIRCUIT

< DTC/CIRCUIT DIAGNOSIS >

1. Turn ignition switch OFF.
2. Disconnect main power window and door lock/unlock switch connector.
3. Turn ignition switch ON.
4. Check voltage between main power window and door lock/unlock switch harness connector and ground.

(+)		(-)	Voltage (Approx.)
Main power window and door lock/unlock switch			
Connector	Terminal	Ground	Battery voltage
D7	10		
D8	18		

Is the inspection result normal?

YES >> GO TO 3.

NO >> GO TO 2.

2. CHECK POWER SUPPLY CIRCUIT

1. Turn ignition switch OFF.
2. Disconnect BCM connector.
3. Check continuity between BCM harness connector and main power window and door lock/unlock switch harness connector.

BCM		Main power window and door lock/unlock switch		Continuity
Connector	Terminal	Connector	Terminal	
M81	140	D7	10	Yes
	141	D8	18	

4. Check continuity between BCM harness connector and ground.

BCM		Ground	Continuity
Connector	Terminal		
M81	140		No
	141		

Is the inspection result normal?

YES >> Replace BCM. Refer to [BCS-82, "Removal and Installation"](#).

NO >> Repair or replace harness.

3. CHECK GROUND CIRCUIT

1. Turn ignition switch OFF.
2. Check continuity between main power window and door lock/unlock switch harness connector and ground.

Main power window and door lock/unlock switch		Ground	Continuity
Connector	Terminal		
D7	1		Yes

Is the inspection result normal?

YES >> GO TO 4.

NO >> Repair or replace harness.

4. CHECK INTERMITTENT INCIDENT

Refer to [GI-42, "Intermittent Incident"](#).

>> Inspection End.

FRONT POWER WINDOW SWITCH (PASSENGER SIDE)

POWER SUPPLY AND GROUND CIRCUIT

< DTC/CIRCUIT DIAGNOSIS >

FRONT POWER WINDOW SWITCH (PASSENGER SIDE) : Diagnosis Procedure

INFOID:000000011218368

Regarding Wiring Diagram information, refer to [PWC-19. "Wiring Diagram"](#).

1. CHECK POWER SUPPLY

1. Turn ignition switch OFF.
2. Disconnect power window and door lock/unlock switch RH connector.
3. Turn ignition switch ON.
4. Check voltage between power window and door lock/unlock switch RH harness connector and ground.

(+)		(-)	Voltage (Approx.)
Connector	Terminal		
D105	8	Ground	Battery voltage

Is the inspection result normal?

YES >> GO TO 3.

NO >> GO TO 2.

2. CHECK POWER SUPPLY CIRCUIT

1. Turn ignition switch OFF.
2. Disconnect BCM connector.
3. Check continuity between BCM harness connector and power window and door lock/unlock switch RH harness connector.

BCM		Power window and door lock/unlock switch RH		Continuity
Connector	Terminal	Connector	Terminal	
M81	141	D105	8	Yes

Is the inspection result normal?

YES >> Replace BCM. Refer to [BCS-82. "Removal and Installation"](#).

NO >> Repair or replace harness.

3. CHECK GROUND CIRCUIT

1. Turn ignition switch OFF.
2. Check continuity between power window and door lock/unlock switch RH harness connector and ground.

Power window and door lock/unlock switch RH		Ground	Continuity
Connector	Terminal		
D105	7		Yes

Is the inspection result normal?

YES >> GO TO 4.

NO >> Repair or replace harness.

4. CHECK INTERMITTENT INCIDENT

Refer to [GI-42. "Intermittent Incident"](#).

>> Inspection End.

REAR POWER WINDOW SWITCH

REAR POWER WINDOW SWITCH : Diagnosis Procedure

INFOID:000000011218369

POWER SUPPLY AND GROUND CIRCUIT

< DTC/CIRCUIT DIAGNOSIS >

Regarding Wiring Diagram information, refer to [PWC-19, "Wiring Diagram"](#).

1. CHECK POWER SUPPLY

1. Turn ignition switch OFF.
2. Disconnect rear power window switch LH connector and rear power window switch RH connector.
3. Turn ignition switch ON.
4. Check voltage between rear power window switch harness connector and ground.

(+)		Terminal	(-)	Voltage (Approx.)
Rear power window switch				
Connector		Terminal	Ground	Battery voltage
LH	D203	4		
RH	D303			

Is the inspection result normal?

YES >> GO TO 3.

NO >> GO TO 2.

2. CHECK POWER SUPPLY CIRCUIT

1. Turn ignition switch OFF.
2. Disconnect BCM connector.
3. Check continuity between BCM harness connector and rear power window switch harness connector.

BCM		Rear power window switch		Continuity
Connector	Terminal	Connector	Terminal	
M81	140	LH	D203	Yes
		RH	D303	

Is the inspection result normal?

YES >> Replace BCM. Refer to [BCS-82, "Removal and Installation"](#).

NO >> Repair or replace harness.

3. CHECK GROUND CIRCUIT

1. Turn ignition switch OFF.
2. Check continuity between rear power window switch harness connector and ground.

Rear power window switch		Terminal	Ground	Continuity
Connector				
LH	D203	2	Ground	Yes
RH	D303			

Is the inspection result normal?

YES >> GO TO 4.

NO >> Repair or replace harness.

4. CHECK INTERMITTENT INCIDENT

Refer to [GI-42, "Intermittent Incident"](#).

>> Inspection End.

POWER WINDOW MOTOR

< DTC/CIRCUIT DIAGNOSIS >

POWER WINDOW MOTOR DRIVER SIDE

DRIVER SIDE : Component Function Check

INFOID:000000011218370

1. CHECK POWER WINDOW MOTOR CIRCUIT

Check front power window motor LH operation with main power window and door lock/unlock switch.

Is the inspection result normal?

YES >> Front power window motor LH is OK.

NO >> Refer to [PWC-38, "DRIVER SIDE : Diagnosis Procedure"](#).

DRIVER SIDE : Diagnosis Procedure

INFOID:000000011218371

Regarding Wiring Diagram information, refer to [PWC-19, "Wiring Diagram"](#).

1. CHECK FRONT POWER WINDOW MOTOR INPUT SIGNAL

1. Turn ignition switch OFF.
2. Disconnect front power window motor LH connector.
3. Turn ignition switch ON.
4. Check voltage between front power window motor LH harness connector and ground.

(+)		(-)	Condition	Voltage (Approx.)	
Connector	Terminal			UP	DOWN
D9	1	Ground	Main power window and door lock/unlock switch	UP	Battery voltage
				DOWN	0
	3			UP	0
				DOWN	Battery voltage

Is the inspection result normal?

YES >> Replace front power window motor LH. Refer to [GW-19, "Removal and Installation"](#).

NO >> GO TO 2.

2. CHECK POWER WINDOW MOTOR CIRCUIT

1. Turn ignition switch OFF.
2. Disconnect main power window and door lock/unlock switch connector.
3. Check continuity between main power window and door lock/unlock switch harness connector and front power window motor LH harness connector.

Main power window and door lock/unlock switch		Front power window motor LH		Continuity
Connector	Terminal	Connector	Terminal	
D8	17	D9	1	Yes
	19		3	

4. Check continuity between main power window and door lock/unlock switch harness connector and ground.

Main power window and door lock/unlock switch		Ground	Continuity
Connector	Terminal		
D8	17		No
	19		

Is the inspection result normal?

POWER WINDOW MOTOR

< DTC/CIRCUIT DIAGNOSIS >

- YES >> Replace main power window and door lock/unlock switch. Refer to [PWC-67. "Removal and Installation"](#).
 NO >> Repair or replace harness.

PASSENGER SIDE

PASSENGER SIDE : Component Function Check

INFOID:000000011218372

1. CHECK POWER WINDOW MOTOR CIRCUIT

Check front power window motor RH operation with main power window and door lock/unlock switch or power window and door lock/unlock switch RH.

Is the inspection result normal?

- YES >> Front power window motor RH is OK.
 NO >> Refer to [PWC-39. "PASSENGER SIDE : Diagnosis Procedure"](#).

PASSENGER SIDE : Diagnosis Procedure

INFOID:000000011218373

Regarding Wiring Diagram information, refer to [PWC-19. "Wiring Diagram"](#).

1. CHECK FRONT POWER WINDOW MOTOR INPUT SIGNAL

- Turn ignition switch OFF.
- Disconnect front power window motor RH connector.
- Turn ignition switch ON.
- Check voltage between front power window motor RH harness connector and ground.

(+)		(-)	Condition	Voltage (Approx.)	
Connector	Terminal			UP	DOWN
D104	1	Ground	Power window and door lock/unlock switch RH	UP	Battery voltage
				DOWN	0
	3			UP	0
				DOWN	Battery voltage

Is the inspection result normal?

- YES >> Replace front power window motor RH. Refer to [GW-19. "Removal and Installation"](#).
 NO >> GO TO 2.

2. CHECK POWER WINDOW MOTOR CIRCUIT

- Turn ignition switch OFF.
- Disconnect power window and door lock/switch RH connector.
- Check continuity between power window and door lock/unlock switch RH harness connector and front power window motor RH harness connector.

Power window and door lock/unlock switch RH		Front power window motor RH		Continuity
Connector	Terminal	Connector	Terminal	
D105	11	D104	1	Yes
	12		3	

- Check continuity between power window and door lock/unlock switch RH connector and ground.

Power window and door lock/unlock switch RH		Ground	Continuity
Connector	Terminal		
D105	11		No
	12		

A
B
C
D
E
F
G
H
I
J
L
M
N
O
P



POWER WINDOW MOTOR

< DTC/CIRCUIT DIAGNOSIS >

Is the inspection result normal?

- YES >> Replace power window and door lock/unlock switch RH. Refer to [PWC-68, "Removal and Installation"](#).
 NO >> Repair or replace harness.

REAR LH

REAR LH : Component Function Check

INFOID:000000011218374

1.CHECK POWER WINDOW MOTOR CIRCUIT

Check rear power window motor LH operation with main power window and door lock/unlock switch or rear power window switch LH.

Is the inspection result normal?

- YES >> Rear power window motor LH is OK.
 NO >> Refer to [PWC-40, "REAR LH : Diagnosis Procedure"](#).

REAR LH : Diagnosis Procedure

INFOID:000000011218375

Regarding Wiring Diagram information, refer to [PWC-19, "Wiring Diagram"](#).

1.CHECK REAR POWER WINDOW MOTOR INPUT SIGNAL

1. Turn ignition switch OFF.
2. Disconnect rear power window motor LH connector.
3. Turn ignition switch ON.
4. Check voltage between rear power window motor LH harness connector and ground.

(+)		(-)	Condition	Voltage (Approx.)	
Connector	Terminal				
D204	3	Ground	Rear power window switch LH	UP	Battery voltage
				DOWN	0
	1			UP	0
				DOWN	Battery voltage

Is the inspection result normal?

- YES >> Replace rear power window motor LH. Refer to [GW-24, "Removal and Installation"](#).
 NO >> GO TO 2.

2.CHECK POWER WINDOW MOTOR CIRCUIT

1. Turn ignition switch OFF.
2. Disconnect rear power window switch LH connector.
3. Check continuity between rear power window switch LH harness connector and rear power window motor LH harness connector.

Rear power window switch LH		Rear power window motor LH		Continuity
Connector	Terminal	Connector	Terminal	
D203	5	D204	3	Yes
	6		1	

4. Check continuity between rear power window switch LH harness connector and ground.

POWER WINDOW MOTOR

< DTC/CIRCUIT DIAGNOSIS >

Rear power window switch LH		Ground	Continuity
Connector	Terminal		
D203	5		No
	6		

Is the inspection result normal?

- YES >> Replace rear power window switch LH. Refer to [PWC-69. "Removal and Installation"](#).
 NO >> Repair or replace harness.

REAR RH

REAR RH : Component Function Check

INFOID:000000011218376

1. CHECK POWER WINDOW MOTOR CIRCUIT

Check rear power window motor RH operation with main power window and door lock/unlock switch or rear power window switch RH.

Is the inspection result normal?

- YES >> Rear power window motor RH is OK.
 NO >> Refer to [PWC-41. "REAR RH : Diagnosis Procedure"](#).

REAR RH : Diagnosis Procedure

INFOID:000000011218377

Regarding Wiring Diagram information, refer to [PWC-19. "Wiring Diagram"](#).

1. CHECK REAR POWER WINDOW MOTOR INPUT SIGNAL

- Turn ignition switch OFF.
- Disconnect rear power window motor RH connector.
- Turn ignition switch ON.
- Check voltage between rear power window motor RH harness connector and ground.

(+)		(-)	Condition	Voltage (Approx.)	
Connector	Terminal				
D304	1	Ground	Rear power window switch RH	UP	0
				DOWN	Battery voltage
	3			UP	Battery voltage
				DOWN	0

Is the inspection result normal?

- YES >> Replace rear power window motor RH. Refer to [GW-24. "Removal and Installation"](#).
 NO >> GO TO 2.

2. CHECK POWER WINDOW MOTOR CIRCUIT

- Turn ignition switch OFF.
- Disconnect rear power window switch RH connector.
- Check continuity between rear power window switch RH harness connector and rear power window motor RH harness connector.

Rear power window switch RH		Rear power window motor RH		Continuity
Connector	Terminal	Connector	Terminal	
D303	6	D304	1	Yes
	5		3	

- Check continuity between rear power window switch RH harness connector and ground.

POWER WINDOW MOTOR

< DTC/CIRCUIT DIAGNOSIS >

Rear power window switch RH		Ground	Continuity
Connector	Terminal		
D303	6		No
	5		

Is the inspection result normal?

- YES >> Replace rear power window switch RH. Refer to [PWC-69, "Removal and Installation"](#).
NO >> Repair or replace harness.

ENCODER

< DTC/CIRCUIT DIAGNOSIS >

ENCODER DRIVER SIDE

DRIVER SIDE : Component Function Check

INFOID:0000000011218378

1.CHECK ENCODER

Check that driver side door glass performs AUTO open/close operation normally by main power window and door lock/unlock switch.

Is the inspection result normal?

- YES >> Encoder is OK.
- NO >> Refer to [PWC-43, "DRIVER SIDE : Diagnosis Procedure"](#).

DRIVER SIDE : Diagnosis Procedure

INFOID:0000000011218379

Regarding Wiring Diagram information, refer to [PWC-19, "Wiring Diagram"](#).

1.CHECK ENCODER SIGNAL

1. Turn ignition switch ON.
2. Check signal between main power window and door lock/unlock switch harness connector and ground with oscilloscope.

Signal name	(+)		(-)	Signal (Reference value)
	Main power window and door lock/unlock switch			
	Connector	Terminal		
Encoder signal 1	D7	5	Ground	Refer to following signal
Encoder signal 2		4		

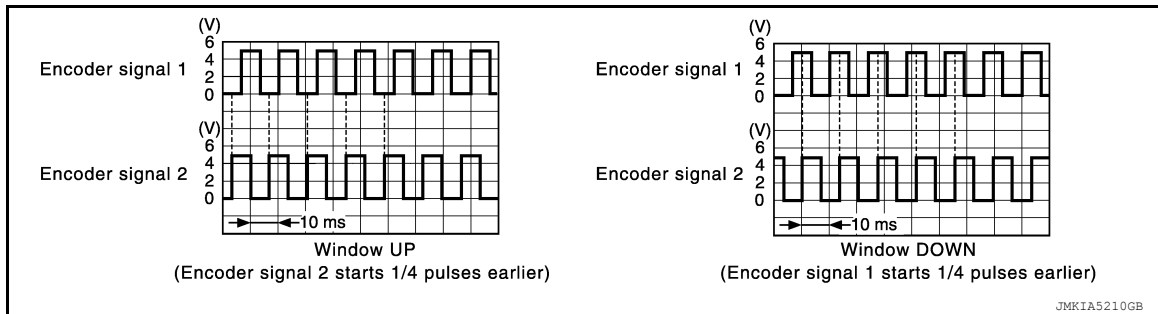

Is the inspection result normal?

- YES >> Replace main power window and door lock/unlock switch. Refer to [PWC-67, "Removal and Installation"](#).
- NO >> GO TO 2.

2.CHECK ENCODER SIGNAL CIRCUIT

1. Turn ignition switch OFF.
2. Disconnect main power window and door lock/unlock switch connector and front power window motor LH connector.
3. Check continuity between main power window and door lock/unlock switch harness connector and front power window motor LH harness connector.

Main power window and door lock/unlock switch		Front power window motor LH		Continuity
Connector	Terminal	Connector	Terminal	
D7	4	D9	6	Yes
	5		5	

A
B
C
D
E
F
G
H
I
J
L
M
N
O
P

PWC

ENCODER

< DTC/CIRCUIT DIAGNOSIS >

4. Check continuity between main power window and door lock/unlock switch harness connector and ground.

Main power window and door lock/unlock switch		Ground	Continuity
Connector	Terminal		
D7	4		No
	5		

Is the inspection result normal?

YES >> GO TO 3.

NO >> Repair or replace harness.

3.CHECK ENCODER POWER SUPPLY

1. Connect main power window and door lock/unlock switch connector.
2. Turn ignition switch ON.
3. Check voltage between front power window motor LH harness connector and ground.

(+)		(-)	Voltage (Approx.)
Front power window motor LH			
Connector	Terminal		
D9	2	Ground	Battery voltage

Is the inspection result normal?

YES >> GO TO 5.

NO >> GO TO 4.

4.CHECK ENCODER POWER SUPPLY CIRCUIT

1. Turn ignition switch OFF.
2. Disconnect main power window and door lock/unlock switch connector.
3. Check continuity between main power window and door lock/unlock switch harness connector and front power window motor LH harness connector.

Main power window and door lock/unlock switch		Front power window motor LH		Continuity
Connector	Terminal	Connector	Terminal	
D7	14	D9	2	Yes

4. Check continuity between main power window and door lock/unlock switch harness connector and ground.

Main power window and door lock/unlock switch		Ground	Continuity
Connector	Terminal		
D7	14		No

Is the inspection result normal?

YES >> Replace main power window and door lock/unlock switch. Refer to [PWC-67. "Removal and Installation"](#).

NO >> Repair or replace harness.

5.CHECK GROUND CIRCUIT 1

1. Turn ignition switch OFF.
2. Check continuity between front power window motor LH harness connector and ground.

Front power window motor LH		Ground	Continuity
Connector	Terminal		
D9	4		Yes

Is the inspection result normal?

YES >> Replace front power window motor LH. Refer to [GW-19. "Removal and Installation"](#).

ENCODER

< DTC/CIRCUIT DIAGNOSIS >

NO >> GO TO 6.

6.CHECK GROUND CIRCUIT 2

1. Disconnect main power window and door lock/unlock switch connector.
2. Check continuity between main power window and door lock/unlock switch harness connector and front power window motor LH harness connector.

Main power window and door lock/unlock switch		Front power window motor LH		Continuity
Connector	Terminal	Connector	Terminal	
D7	12	D9	4	Yes

3. Check continuity between main power window and door lock/unlock switch harness connector and ground.

Main power window and door lock/unlock switch		Ground	Continuity
Connector	Terminal		
D7	12		No

Is the inspection result normal?

YES >> Replace main power window and door lock/unlock switch. Refer to [PWC-67. "Removal and Installation"](#).

NO >> Repair or replace harness.

PASSENGER SIDE

PASSENGER SIDE : Component Function Check

INFOID:000000011218380

1.CHECK ENCODER

Check that passenger side door glass performs AUTO open/close operation normally by main power window and door lock/unlock switch or power window and door lock/unlock switch RH.

Is the inspection result normal?

YES >> Encoder is OK.

NO >> Refer to [PWC-45. "PASSENGER SIDE : Diagnosis Procedure"](#).

PASSENGER SIDE : Diagnosis Procedure

INFOID:000000011218381

PWC

Regarding Wiring Diagram information, refer to [PWC-19. "Wiring Diagram"](#).

1.CHECK ENCODER SIGNAL

1. Turn ignition switch ON.
2. Check signal between power window and door lock/unlock switch RH harness connector and ground with oscilloscope.

Signal name	(+)		(-)	Signal (Reference value)
	Power window and door lock/unlock switch RH			
	Connector	Terminal		
Encoder signal 1	D105	9	Ground	Refer to following signal
Encoder signal 2		10		

ENCODER

< DTC/CIRCUIT DIAGNOSIS >

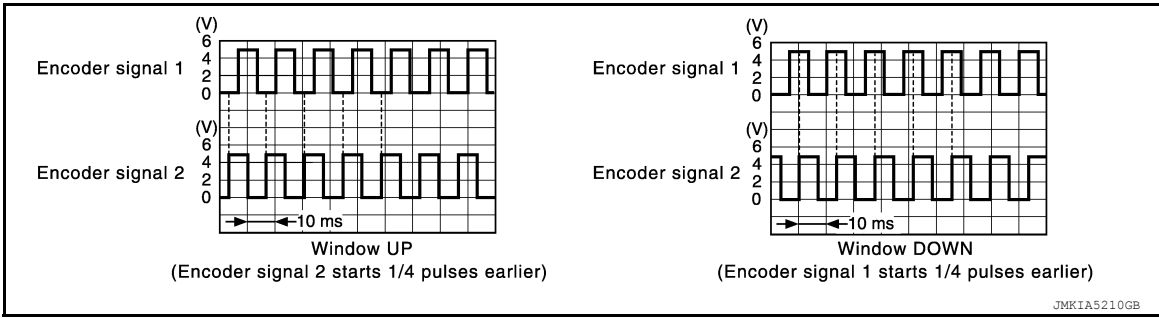

Is the inspection result normal?

YES >> Replace power window and door lock/unlock switch RH. Refer to [PWC-68, "Removal and Installation"](#).

NO >> GO TO 2.

2. CHECK ENCODER SIGNAL CIRCUIT

1. Turn ignition switch OFF.
2. Disconnect power window and door lock/unlock switch RH connector and power window and door lock/unlock switch motor RH connector.
3. Check continuity between power window and door lock/unlock switch RH harness connector and front power window motor RH harness connector.

Power window and door lock/unlock switch RH		Front power window motor RH		Continuity
Connector	Terminal	Connector	Terminal	
D105	9	D104	5	Yes
	10		6	

4. Check continuity between power window and door lock/unlock switch RH harness connector and ground.

Power window and door lock/unlock switch RH		Ground	Continuity
Connector	Terminal		
D105	9		No
	10		

Is the inspection result normal?

YES >> GO TO 3.

NO >> Repair or replace harness.

3. CHECK ENCODER POWER SUPPLY

1. Connect power window and door lock/unlock switch RH connector.
2. Turn ignition switch ON.
3. Check voltage between power window and door lock/unlock switch RH harness connector and ground.

(+)		(-)	Voltage (Approx.)
Power window and door lock/unlock switch RH			
Connector	Terminal		
D104	2	Ground	Battery voltage

Is the inspection result normal?

YES >> GO TO 5.

NO >> GO TO 4.

4. CHECK ENCODER POWER SUPPLY CIRCUIT

1. Turn ignition switch OFF.
2. Disconnect power window and door lock/unlock switch RH connector.
3. Check continuity between power window and door lock/unlock switch RH harness connector and power window and door lock/unlock motor RH harness connector.

ENCODER

< DTC/CIRCUIT DIAGNOSIS >

Power window and door lock/unlock switch RH		Front power window motor RH		Continuity
Connector	Terminal	Connector	Terminal	
D105	5	D104	2	Yes

4. Check continuity between power window and door lock/unlock switch RH harness connector and ground.

Power window and door lock/unlock switch RH		Ground	Continuity
Connector	Terminal		
D105	5		No

Is the inspection result normal?

YES >> Replace power window and door lock/unlock switch RH. Refer to [PWC-68, "Removal and Installation"](#).

NO >> Repair or replace harness.

5. CHECK GROUND CIRCUIT 1

1. Turn ignition switch OFF.
2. Check continuity between front power window motor RH harness connector and ground.

Front power window motor RH		Ground	Continuity
Connector	Terminal		
D104	4		Yes

Is the inspection result normal?

YES >> Replace front power window motor RH. Refer to [GW-19, "Removal and Installation"](#).

NO >> GO TO 6.

6. CHECK GROUND CIRCUIT 2

1. Disconnect power window and door lock/unlock switch RH connector.
2. Check continuity between power window and door lock/unlock switch RH harness connector and front power window motor RH harness connector.

Power window and door lock/unlock switch RH		Front power window motor RH		Continuity
Connector	Terminal	Connector	Terminal	
D105	4	D104	4	Yes

3. Check continuity between power window and door lock/unlock switch RH harness connector and ground.

Power window and door lock/unlock switch RH		Ground	Continuity
Connector	Terminal		
D105	4		No

Is the inspection result normal?

YES >> Replace power window and door lock/unlock switch RH. Refer to [PWC-68, "Removal and Installation"](#).

NO >> Repair or replace harness.

DOOR KEY CYLINDER SWITCH

< DTC/CIRCUIT DIAGNOSIS >

DOOR KEY CYLINDER SWITCH

Component Function Check

INFOID:000000011565224

1. CHECK FUNCTION

CONSULT

1. Select "DOOR LOCK" of "BCM".
2. Select "KEY CYL LK-SW" or "KEY CYL UN-SW" in "Data Monitor" mode.
3. Check that the function operates normally according to the following conditions:

Monitor Item	Condition	Status
KEY CYL LK-SW	Lock	ON
	Neutral / Unlock	OFF
KEY CYL UN-SW	Unlock	ON
	Neutral / Lock	OFF

Is the inspection result normal?

- YES >> Door key cylinder switch is OK.
NO >> Refer to [PWC-48, "Diagnosis Procedure"](#).

Diagnosis Procedure

INFOID:000000011565225

Regarding Wiring Diagram information, refer to [DLK-76, "Wiring Diagram"](#).

1. CHECK DOOR KEY CYLINDER SWITCH INPUT SIGNAL

1. Turn ignition switch OFF.
2. Disconnect front door lock assembly LH connector.
3. Check voltage between front door lock assembly LH harness connector and ground.

(+) Front door lock assembly LH		(-)	Voltage (Approx.)
Connector	Terminal		
D14	5	Ground	5 V
	6		

Is the inspection result normal?

- YES >> GO TO 3.
NO >> GO TO 2.

2. CHECK DOOR KEY CYLINDER SWITCH SIGNAL CIRCUIT

1. Disconnect main power window and door lock/unlock switch connector.
2. Check continuity between main power window and door lock/unlock switch harness connector and front door lock assembly LH harness connector.

Main power window and door lock/unlock switch		Front door lock assembly LH		Continuity
Connector	Terminal	Connector	Terminal	
D7	3	D14	6	Yes
	15		5	

3. Check continuity between power window main switch harness connector and ground.

DOOR KEY CYLINDER SWITCH

< DTC/CIRCUIT DIAGNOSIS >

Main power window and door lock/unlock switch		Ground	Continuity
Connector	Terminal		
D7	3		No
	15		

Is the inspection result normal?

YES >> Replace main power window and door lock/unlock switch. Refer to [PWC-67, "Removal and Installation"](#).

NO >> Repair or replace harness.

3.CHECK DOOR KEY CYLINDER SWITCH GROUND CIRCUIT

Check continuity between front door lock assembly LH harness connector and ground.

Front door lock assembly LH		Ground	Continuity
Connector	Terminal		
D14	4		Yes

Is the inspection result normal?

YES >> GO TO 4.

NO >> Repair or replace harness.

4.CHECK DOOR KEY CYLINDER SWITCH

Refer to [PWC-49, "Component Inspection"](#).

Is the inspection result normal?

YES >> GO TO 5.

NO >> Replace front door lock assembly LH. Refer to [DLK-290, "DOOR LOCK : Removal and Installation"](#).

5.CHECK INTERMITTENT INCIDENT

Refer to [GI-42, "Intermittent Incident"](#).

>> Inspection End.

Component Inspection

INFOID:000000011565226

PWC

1.CHECK DOOR KEY CYLINDER SWITCH

1. Turn ignition switch OFF.
2. Disconnect front door lock assembly LH connector.
3. Check continuity between front door lock assembly LH terminals.

Front door lock assembly LH		Condition	Continuity
Terminal			
5	4	Driver side door key cylinder	Unlock
			Neutral / Lock
6			Lock
			Neutral / Unlock
			Yes
			No
			Yes
			No

Is the inspection result normal?

YES >> Inspection End.

NO >> Replace front door lock assembly LH. Refer to [DLK-290, "DOOR LOCK : Removal and Installation"](#).

POWER WINDOW SERIAL LINK

< DTC/CIRCUIT DIAGNOSIS >

POWER WINDOW SERIAL LINK

POWER WINDOW MAIN SWITCH

POWER WINDOW MAIN SWITCH : Description

INFOID:0000000011568144

Main power window and door lock/unlock switch, power window and door lock/unlock switch RH and BCM transmit and receive the signal by power window serial link.

The signal mentioned below is transmitted from BCM to main power window and door lock/unlock switch and power window and door lock/unlock switch RH:

- Keyless power window down signal

The signal mentioned below is transmitted from main power window and door lock/unlock switch to power window and door lock/unlock switch RH:

- Front door window RH operation signal
- Power window control by key cylinder switch signal
- Power window lock switch signal
- Retained power operation signal

POWER WINDOW MAIN SWITCH : Component Function Check

INFOID:0000000011568145

1. CHECK POWER WINDOW SWITCH OUTPUT SIGNAL

Check "CDL LOCK SW", "CDL UNLOCK SW" in "DATA MONITOR" mode of "BCM (DOOR LOCK)" with CONSULT. Refer to [BCS-16, "DOOR LOCK : CONSULT Function \(BCM - DOOR LOCK\)"](#).

Monitor item	Condition
CDL LOCK SW	LOCK : ON
	UNLOCK : OFF
CDL UNLOCK SW	LOCK : OFF
	UNLOCK : ON

Is the inspection result normal?

YES >> Power window serial link is OK.

NO >> Refer to [PWC-50, "POWER WINDOW MAIN SWITCH : Diagnosis Procedure"](#).

POWER WINDOW MAIN SWITCH : Diagnosis Procedure

INFOID:0000000011568146

Regarding Wiring Diagram information, refer to [PWC-19, "Wiring Diagram"](#).

Power Window Serial Link Check

1. CHECK POWER WINDOW SWITCH OUTPUT SIGNAL

1. Remove key and close front door LH and RH.
2. Check signal between BCM connector and ground with oscilloscope when door lock and unlock switch (LH and RH) is turned to "LOCK" or "UNLOCK".
3. Check that signals which are shown in the figure below can be detected during 10 second just after door lock and unlock switch (LH and RH) is turned to "LOCK" or "UNLOCK".

POWER WINDOW SERIAL LINK

< DTC/CIRCUIT DIAGNOSIS >

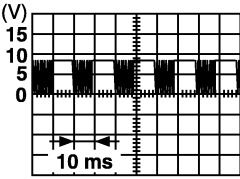
Terminal		Signal (Reference value)
(+)	(-)	
BCM connector	Terminal	
M19	54	 <p style="text-align: right; font-size: small;">PIIA1297E</p>

Is the inspection result normal?

- YES >> Power window serial link is OK.
 NO >> GO TO 2.

2. CHECK POWER WINDOW SERIAL LINK CIRCUIT

- Turn ignition switch OFF.
- Disconnect BCM and main power window and door lock/unlock switch.
- Check continuity between BCM connector and main power window and door lock/unlock switch connector.

BCM connector	Terminal	Main power window and door lock/unlock switch connector	Terminal	Continuity
M19	54	D7	11	Yes

- Check continuity between BCM connector and ground.

BCM connector	Terminal	Ground	Continuity
M19	54		No

Is the inspection result normal?

- YES >> Replace main power window and door lock/unlock switch. Refer to [PWC-67. "Removal and Installation"](#).
 NO >> Repair or replace harness or connectors.

FRONT POWER WINDOW SWITCH

FRONT POWER WINDOW SWITCH : Description

INFOID:0000000011568147

Main power window and door lock/unlock switch, power window and door lock/unlock switch RH and BCM transmit and receive the signal by power window serial link.

The signal mentioned below is transmitted from BCM to main power window and door lock/unlock switch and power window and door lock/unlock switch RH

- Keyless power window down signal

The signal mentioned below is transmitted from main power window and door lock/unlock switch to power window and door lock/unlock switch RH

- Front door window RH operation signal
- Power window control by key cylinder switch signal
- Retained power operation signal
- Power window lock switch signal

FRONT POWER WINDOW SWITCH : Component Function Check

INFOID:0000000011568148

1. CHECK POWER WINDOW AND DOOR LOCK/UNLOCK SWITCH RH OUTPUT SIGNAL

Check "CDL LOCK SW", "CDL UNLOCK SW" in "DATA MONITOR" mode of "" with CONSULT. Refer to [BCS-16. "DOOR LOCK : CONSULT Function \(BCM - DOOR LOCK\)"](#).

POWER WINDOW SERIAL LINK

< DTC/CIRCUIT DIAGNOSIS >

Monitor item	Condition	
CDL LOCK SW	LOCK	: ON
	UNLOCK	: OFF
CDL UNLOCK SW	LOCK	: OFF
	UNLOCK	: ON

Is the inspection result normal?

YES >> Power window serial link is OK.

NO >> Refer to [PWC-52, "FRONT POWER WINDOW SWITCH : Diagnosis Procedure"](#).

FRONT POWER WINDOW SWITCH : Diagnosis Procedure

INFOID:000000011568149

Regarding Wiring Diagram information, refer to [PWC-19, "Wiring Diagram"](#).

Power Window Serial Link Check

1. CHECK POWER WINDOW AND DOOR LOCK/UNLOCK SWITCH RH

1. Remove key and close the front door LH and RH.
2. Check signal between BCM connector and ground with oscilloscope when door lock and unlock switch (LH and RH) is turned to "LOCK" or "UNLOCK".
3. Check that signals which are shown in the figure below can be detected during 10 second just after door lock and unlock switch (LH and RH) is turned to "LOCK" or "UNLOCK".

Terminal		Signal (Reference value)
(+)	(-)	
BCM connector	Terminal	
M19	54	Ground

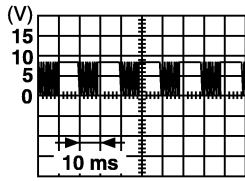

PIIA1297E

Is the inspection result normal?

YES >> Power window serial link is OK.

NO >> GO TO 2.

2. CHECK POWER WINDOW SERIAL LINK CIRCUIT

1. Turn ignition switch OFF.
2. Disconnect BCM.
3. Check continuity between BCM connector and power window and door lock/unlock switch RH connector.

BCM connector	Terminal	Power window and door lock/unlock switch RH connector	Terminal	Continuity
M19	54	D105	3	Yes

4. Check continuity between BCM connector and ground.

BCM connector	Terminal	Ground	Continuity
M19	54		No

Is the inspection result normal?

YES >> Replace main power window and door lock/unlock switch. Refer to [PWC-67, "Removal and Installation"](#).

POWER WINDOW SERIAL LINK

< DTC/CIRCUIT DIAGNOSIS >

NO >> Repair or replace the harness or connectors.

A

B

C

D

E

F

G

H

I

J

PWC

L

M

N

O

P

POWER WINDOWS DO NOT OPERATE WITH POWER WINDOW MAIN SWITCH

< SYMPTOM DIAGNOSIS >

SYMPTOM DIAGNOSIS

POWER WINDOWS DO NOT OPERATE WITH POWER WINDOW MAIN SWITCH

Diagnosis Procedure

INFOID:000000011218397

1. CHECK BCM POWER SUPPLY AND GROUND CIRCUIT

Check BCM power supply and ground circuit.

[BCS-82, "Removal and Installation"](#).

Is the inspection result normal?

YES >> GO TO 2.

NO >> Repair or replace the malfunctioning parts.

2. CHECK MAIN POWER WINDOW AND DOOR LOCK/UNLOCK SWITCH POWER SUPPLY AND GROUND CIRCUIT

Check main power window and door lock/unlock switch power supply and ground circuit.

Refer to [PWC-34, "POWER WINDOW MAIN SWITCH : Diagnosis Procedure"](#).

Is the inspection result normal?

YES >> GO TO 3.

NO >> Repair or replace the malfunctioning parts.

3. CONFIRM THE OPERATION

Confirm the operation again.

Is the inspection result normal?

YES >> Check intermittent incident. Refer to [GI-42, "Intermittent Incident"](#).

NO >> GO TO 1.

DRIVER SIDE POWER WINDOW ALONE DOES NOT OPERATE

< SYMPTOM DIAGNOSIS >

DRIVER SIDE POWER WINDOW ALONE DOES NOT OPERATE

Diagnosis Procedure

INFOID:000000011218398

1. CHECK FRONT POWER WINDOW MOTOR LH

Check front power window motor LH.

Refer to [PWC-38, "DRIVER SIDE : Component Function Check"](#).

Is the inspection result normal?

YES >> GO TO 2.

NO >> Repair or replace the malfunctioning parts.

2. CONFIRM THE OPERATION

Confirm the operation again.

Is the inspection result normal?

YES >> Check intermittent incident. Refer to [GI-42, "Intermittent Incident"](#).

NO >> GO TO 1.

A
B
C
D
E
F
G
H
I
J
L
M
N
O
P

PWC

FRONT PASSENGER SIDE POWER WINDOW DOES NOT OPERATE

< SYMPTOM DIAGNOSIS >

FRONT PASSENGER SIDE POWER WINDOW DOES NOT OPERATE WHEN POWER WINDOW MAIN SWITCH IS OPERATED

WHEN POWER WINDOW MAIN SWITCH IS OPERATED : Diagnosis Procedure

INFOID:000000011218399

1. CHECK POWER WINDOW AND DOOR LOCK/UNLOCK SWITCH RH

Check power window and door lock/unlock switch RH serial link circuit.

Is the inspection result normal?

YES >> GO TO 2.

NO >> Repair or replace the malfunctioning parts.

2. CONFIRM THE OPERATION

Confirm the operation again.

Is the inspection result normal?

YES >> Check intermittent incident. Refer to [GI-42, "Intermittent Incident"](#).

NO >> GO TO 1.

WHEN FRONT POWER WINDOW SWITCH (PASSENGER SIDE) IS OPERATED

WHEN FRONT POWER WINDOW SWITCH (PASSENGER SIDE) IS OPERATED :
Diagnosis Procedure

INFOID:000000011218400

1. REPLACE POWER WINDOW AND DOOR LOCK/UNLOCK SWITCH RH

Replace power window and door lock/unlock switch RH.

Refer to [PWC-68, "Removal and Installation"](#).

>> Inspection End.

WHEN BOTH POWER WINDOW MAIN SWITCH AND FRONT POWER WINDOW
SWITCH ARE OPERATED

WHEN BOTH POWER WINDOW MAIN SWITCH AND FRONT POWER WINDOW
SWITCH ARE OPERATED : Diagnosis Procedure

INFOID:000000011218401

1. CHECK FRONT POWER WINDOW SWITCH (PASSENGER SIDE) POWER SUPPLY AND GROUND CIRCUIT

Check power window and door lock/unlock switch RH power supply and ground circuit.

Refer to [PWC-36, "FRONT POWER WINDOW SWITCH \(PASSENGER SIDE\) : Diagnosis Procedure"](#).

Is the inspection result normal?

YES >> GO TO 2.

NO >> Repair or replace the malfunctioning parts.

2. CHECK FRONT POWER WINDOW MOTOR RH CIRCUIT

Check front power window motor RH circuit.

Refer to [PWC-39, "PASSENGER SIDE : Component Function Check"](#).

Is the inspection result normal?

YES >> GO TO 3.

NO >> Repair or replace the malfunctioning parts.

3. CONFIRM THE OPERATION

Confirm the operation again.

Is the inspection result normal?

YES >> Check intermittent incident. Refer to [GI-42, "Intermittent Incident"](#).

NO >> GO TO 1.

REAR LH SIDE POWER WINDOW ALONE DOES NOT OPERATE

< SYMPTOM DIAGNOSIS >

REAR LH SIDE POWER WINDOW ALONE DOES NOT OPERATE WHEN POWER WINDOW MAIN SWITCH IS OPERATED

WHEN POWER WINDOW MAIN SWITCH IS OPERATED : Diagnosis Procedure

INFOID:000000011218402

1.CONFIRM THE OPERATION

Confirm the operation again.

Is the inspection result normal?

YES >> Check intermittent incident. Refer to [GI-42, "Intermittent Incident"](#).

NO >> GO TO 1.

WHEN REAR POWER WINDOW SWITCH LH IS OPERATED

WHEN REAR POWER WINDOW SWITCH LH IS OPERATED : Diagnosis Procedure

INFOID:000000011218403

1.REPLACE REAR POWER WINDOW SWITCH LH

Replace rear power window switch LH.

Refer to [PWC-69, "Removal and Installation"](#).

>> Inspection End.

WHEN BOTH POWER WINDOW MAIN SWITCH AND REAR POWER WINDOW SWITCH LH ARE OPERATED

WHEN BOTH POWER WINDOW MAIN SWITCH AND REAR POWER WINDOW
SWITCH LH ARE OPERATED : Diagnosis Procedure

INFOID:000000011218404

1.CHECK REAR POWER WINDOW SWITCH POWER SUPPLY AND GROUND CIRCUIT

Check rear power window switch power supply and ground circuit.

Refer to [PWC-36, "REAR POWER WINDOW SWITCH : Diagnosis Procedure"](#).

Is the inspection result normal?

YES >> GO TO 2.

NO >> Repair or replace the malfunctioning parts.

2.CHECK REAR POWER WINDOW MOTOR LH

Check rear power window motor LH.

Refer to [PWC-40, "REAR LH : Component Function Check"](#).

Is the inspection result normal?

YES >> GO TO 3.

NO >> Repair or replace the malfunctioning parts.

3.CONFIRM THE OPERATION

Confirm the operation again.

Is the inspection result normal?

YES >> Check intermittent incident. Refer to [GI-42, "Intermittent Incident"](#).

NO >> GO TO 1.

A
B
C
D
E
F
G
H
I
J
L
M
N
O
P

PWC

REAR RH SIDE POWER WINDOW ALONE DOES NOT OPERATE

< SYMPTOM DIAGNOSIS >

REAR RH SIDE POWER WINDOW ALONE DOES NOT OPERATE WHEN POWER WINDOW MAIN SWITCH IS OPERATED

WHEN POWER WINDOW MAIN SWITCH IS OPERATED : Diagnosis Procedure

INFOID:000000011218405

1. CONFIRM THE OPERATION

Confirm the operation again.

Is the inspection result normal?

YES >> Check intermittent incident. Refer to [GI-42, "Intermittent Incident"](#).

NO >> GO TO 1.

WHEN REAR POWER WINDOW SWITCH RH IS OPERATED

WHEN REAR POWER WINDOW SWITCH RH IS OPERATED : Diagnosis Procedure

INFOID:000000011218406

1. REPLACE REAR POWER WINDOW SWITCH RH

Replace rear power window switch RH.

Refer to [PWC-69, "Removal and Installation"](#).

>> Inspection End.

WHEN BOTH POWER WINDOW MAIN SWITCH AND REAR POWER WINDOW SWITCH RH ARE OPERATED

WHEN BOTH POWER WINDOW MAIN SWITCH AND REAR POWER WINDOW
SWITCH RH ARE OPERATED : Diagnosis Procedure

INFOID:000000011218407

1. CHECK REAR POWER WINDOW SWITCH POWER SUPPLY AND GROUND CIRCUIT

Check rear power window switch power supply and ground circuit.

Refer to [PWC-36, "REAR POWER WINDOW SWITCH : Diagnosis Procedure"](#).

Is the inspection result normal?

YES >> GO TO 2.

NO >> Repair or replace the malfunctioning parts.

2. CHECK REAR POWER WINDOW MOTOR RH

Check rear power window motor RH.

Refer to [PWC-41, "REAR RH : Component Function Check"](#).

Is the inspection result normal?

YES >> GO TO 3.

NO >> Repair or replace the malfunctioning parts.

3. CONFIRM THE OPERATION

Confirm the operation again.

Is the inspection result normal?

YES >> Check intermittent incident. Refer to [GI-42, "Intermittent Incident"](#).

NO >> GO TO 1.

AUTO OPERATION DOES NOT OPERATE BUT MANUAL OPERATE NORMALLY

< SYMPTOM DIAGNOSIS >

AUTO OPERATION DOES NOT OPERATE BUT MANUAL OPERATE NORMALLY

DRIVER SIDE

DRIVER SIDE : Diagnosis Procedure

INFOID:0000000011218408

1.PERFORM INITIALIZATION PROCEDURE

Initialization procedure is performed and operation is confirmed.
Refer to [PWC-32. "Work Procedure"](#).

Is the inspection result normal?

YES >> Inspection End.
NO >> GO TO 2.

2.CHECK ENCODER (DRIVER SIDE) CIRCUIT

Check encoder (driver side) circuit.
Refer to [PWC-43. "DRIVER SIDE : Component Function Check"](#).

Is the inspection result normal?

YES >> GO TO 3.
NO >> Repair or replace the malfunctioning parts.

3.CONFIRM THE OPERATION

Confirm the operation again.

Is the inspection result normal?

YES >> Check intermittent incident. Refer to [GI-42. "Intermittent Incident"](#).
NO >> GO TO 1.

PASSENGER SIDE

PASSENGER SIDE : Diagnosis Procedure

INFOID:0000000011218409

1.PERFORM INITIALIZATION PROCEDURE

Initialization procedure is performed and operation is confirmed.
Refer to [PWC-32. "Work Procedure"](#).

Is the inspection result normal?

YES >> Inspection End.
NO >> GO TO 2.

2.CHECK ENCODER (PASSENGER SIDE) CIRCUIT

Check encoder (passenger side) circuit.
Refer to [PWC-45. "PASSENGER SIDE : Component Function Check"](#).

Is the inspection result normal?

YES >> GO TO 3.
NO >> Repair or replace the malfunctioning parts.

3.CONFIRM THE OPERATION

Confirm the operation again.

Is the inspection result normal?

YES >> Check intermittent incident. Refer to [GI-42. "Intermittent Incident"](#).
NO >> GO TO 1.

REAR LH

REAR LH : Diagnosis Procedure

INFOID:0000000011218410

1.PERFORM INITIALIZATION PROCEDURE

Initialization procedure is performed and operation is confirmed.

A
B
C
D
E
F
G
H
I
J
L
M
N
O
P

PWC

AUTO OPERATION DOES NOT OPERATE BUT MANUAL OPERATE NORMALLY

< SYMPTOM DIAGNOSIS >

Refer to [PWC-32. "Work Procedure"](#).

Is the inspection result normal?

YES >> Inspection End.
NO >> GO TO 2.

2.CONFIRM THE OPERATION

Confirm the operation again.

Is the inspection result normal?

YES >> Check intermittent incident. Refer to [GI-42. "Intermittent Incident"](#).
NO >> GO TO 1.

REAR RH

REAR RH : Diagnosis Procedure

INFOID:000000011218411

1.PERFORM INITIALIZATION PROCEDURE

Initialization procedure is performed and operation is confirmed.

Refer to [PWC-32. "Work Procedure"](#).

Is the inspection result normal?

YES >> Inspection End.
NO >> GO TO 2.

2.CONFIRM THE OPERATION

Confirm the operation again.

Is the inspection result normal?

YES >> Check intermittent incident. Refer to [GI-42. "Intermittent Incident"](#).
NO >> GO TO 1.

ANTI-PINCH FUNCTION DOES NOT OPERATE

< SYMPTOM DIAGNOSIS >

ANTI-PINCH FUNCTION DOES NOT OPERATE

Diagnosis Procedure

INFOID:000000011218412

1. CHECK POWER WINDOW AUTO OPERATION

Check AUTO operation of the door when anti-pinch function does not operate.

Is the inspection result normal?

YES >> GO TO 2.

NO >> Refer to [PWC-59, "DRIVER SIDE : Diagnosis Procedure"](#) (driver side), [PWC-59, "PASSENGER SIDE : Diagnosis Procedure"](#) (passenger side), [PWC-59, "REAR LH : Diagnosis Procedure"](#) (rear LH), [PWC-60, "REAR RH : Diagnosis Procedure"](#) (rear RH).

2. CONFIRM THE OPERATION

Confirm the operation again.

Is the inspection result normal?

YES >> Check intermittent incident. Refer to [GI-42, "Intermittent Incident"](#).

NO >> GO TO 1.

A
B
C
D
E
F
G
H
I
J
L
M
N
O
P

PWC

POWER WINDOW RETAINED POWER FUNCTION DOES NOT OPERATE NORMALLY

< SYMPTOM DIAGNOSIS >

POWER WINDOW RETAINED POWER FUNCTION DOES NOT OPERATE NORMALLY

Diagnosis Procedure

INFOID:000000011218413

1. CHECK DOOR SWITCH

Check door switch.

Refer to [DLK-179, "Component Function Check"](#).

Is the inspection result normal?

YES >> GO TO 2.

NO >> Repair or replace the malfunctioning parts.

2. CONFIRM THE OPERATION

Confirm the operation again.

Is the inspection result normal?

YES >> Check intermittent incident. Refer to [GI-42, "Intermittent Incident"](#).

NO >> GO TO 1.

DOOR KEY CYLINDER SWITCH DOES NOT OPERATE POWER WINDOWS

< SYMPTOM DIAGNOSIS >

DOOR KEY CYLINDER SWITCH DOES NOT OPERATE POWER WINDOWS

Diagnosis Procedure

INFOID:000000011218414

1.PERFORM INITIALIZATION PROCEDURE

Initialization procedure is performed and operation is confirmed.

Refer to [PWC-32, "Work Procedure"](#).

Is the inspection result normal?

YES >> Inspection End.

NO >> GO TO 2.

2.CHECK FRONT DOOR LOCK ASSEMBLY LH (KEY CYLINDER SWITCH)

Check front door lock assembly LH (key cylinder switch).

Refer to [DLK-194, "Component Function Check"](#).

Is the inspection result normal?

YES >> GO TO 3.

NO >> Repair or replace the malfunctioning parts.

3.CONFIRM THE OPERATION

Confirm the operation again.

Is the inspection result normal?

YES >> Check intermittent incident. Refer to [GI-42, "Intermittent Incident"](#).

NO >> GO TO 1.

A
B
C
D
E
F
G
H
I
J
L
M
N
O
P

PWC

KEYLESS POWER WINDOW DOWN DOES NOT OPERATE

< SYMPTOM DIAGNOSIS >

KEYLESS POWER WINDOW DOWN DOES NOT OPERATE

Diagnosis Procedure

INFOID:000000011218415

1.CHECK REMOTE KEYLESS ENTRY FUNCTION

Check remote keyless entry function.

Is the inspection result normal?

YES >> GO TO 2.

NO >> Refer to [DLK-168, "Diagnosis Procedure"](#).

2.CHECK POWER WINDOW OPERATION

Check power window operation.

In the inspection result normal?

YES >> GO TO 3.

NO >> Refer to [PWC-34, "POWER WINDOW MAIN SWITCH : Diagnosis Procedure"](#).

3.CONFIRM THE OPERATION

Confirm the operation again.

Is the inspection result normal?

YES >> Check intermittent incident. Refer to [GI-42, "Intermittent Incident"](#).

NO >> GO TO 1.

POWER WINDOW LOCK SWITCH DOES NOT FUNCTION

< SYMPTOM DIAGNOSIS >

POWER WINDOW LOCK SWITCH DOES NOT FUNCTION

Diagnosis Procedure

INFOID:000000011218416

1. REPLACE MAIN POWER WINDOW AND DOOR LOCK/UNLOCK SWITCH

Replace main power window and door lock/unlock switch. Refer to [PWC-67, "Removal and Installation"](#).

>> Inspection End.

A
B
C
D
E
F
G
H
I
J
L
M
N
O
P

PWC

POWER WINDOW SWITCH DOES NOT ILLUMINATE

< SYMPTOM DIAGNOSIS >

POWER WINDOW SWITCH DOES NOT ILLUMINATE

DRIVER SIDE

DRIVER SIDE : Diagnosis Procedure

INFOID:0000000011218417

1.REPLACE MAIN POWER WINDOW AND DOOR LOCK/UNLOCK SWITCH

Replace main power window and door lock/unlock switch.

Refer to [PWC-67. "Removal and Installation"](#).

>> Inspection End.

PASSENGER SIDE

PASSENGER SIDE : Diagnosis Procedure

INFOID:0000000011218418

1.REPLACE POWER WINDOW AND DOOR LOCK/UNLOCK SWITCH RH

Replace power window and door lock/unlock switch RH.

Refer to [PWC-68. "Removal and Installation"](#).

>> Inspection End.

REAR LH

REAR LH : Diagnosis Procedure

INFOID:0000000011218419

1.REPLACE REAR POWER WINDOW SWITCH LH

Replace rear power window switch LH.

Refer to [PWC-69. "Removal and Installation"](#).

>> Inspection End.

REAR RH

REAR RH : Diagnosis Procedure

INFOID:0000000011218420

1.REPLACE REAR POWER WINDOW SWITCH RH

Replace rear power window switch RH.

Refer to [PWC-69. "Removal and Installation"](#).

>> Inspection End.

MAIN POWER WINDOW AND DOOR LOCK/UNLOCK SWITCH

< REMOVAL AND INSTALLATION >

REMOVAL AND INSTALLATION

MAIN POWER WINDOW AND DOOR LOCK/UNLOCK SWITCH

Removal and Installation

INFOID:0000000011218421

REMOVAL

1. Pull armrest in direction shown (←) then starting at rear release main power window and door lock/unlock switch finisher (1) pawls using a suitable tool (A).

←: Front

○: Pawl

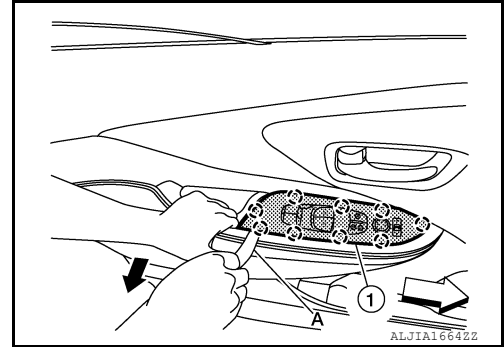

2. Disconnect the harness connectors (A) from the main power window and door lock/unlock switch (1) and harness connector (B) from the door mirror remote control switch (2) and remove.

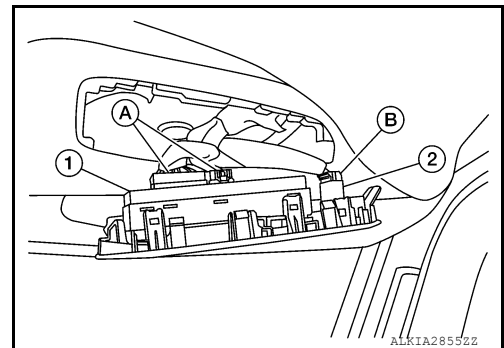

3. Release pawls then separate main power window and door lock/unlock switch (1) from switch finisher (2).

○: Pawl

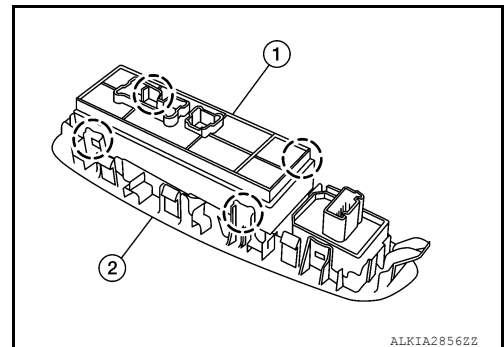

INSTALLATION

Installation is in the reverse order of removal.

NOTE:

When main power window and door lock/unlock switch is removed or replaced, it is necessary to perform initialization procedure. Refer to [PWC-32, "Work Procedure"](#).

A
B
C
D
E
F
G
H
I
J
PWC
L
M
N
O
P

POWER WINDOW AND DOOR LOCK/UNLOCK SWITCH RH

< REMOVAL AND INSTALLATION >

POWER WINDOW AND DOOR LOCK/UNLOCK SWITCH RH

Removal and Installation

INFOID:000000011218422

REMOVAL

1. Pull armrest in direction shown (←) then starting at rear release power window and door lock/unlock switch RH finisher (1) pawls using a suitable tool (A).

←: Front

○: Pawl

NOTE:

LH shown; RH similar.

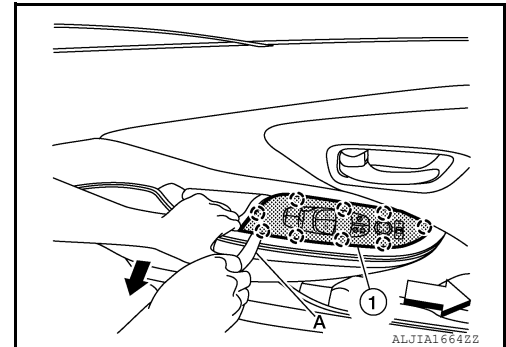

2. Disconnect the harness connector (A) from the power window and door lock/unlock switch RH (1) and remove.

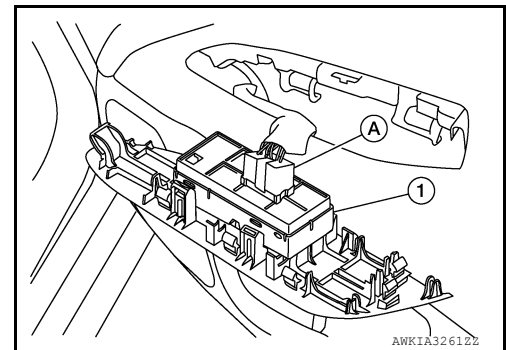

3. Release pawls then separate power window and door lock/unlock switch RH (1) from switch finisher (2).

○: Pawl

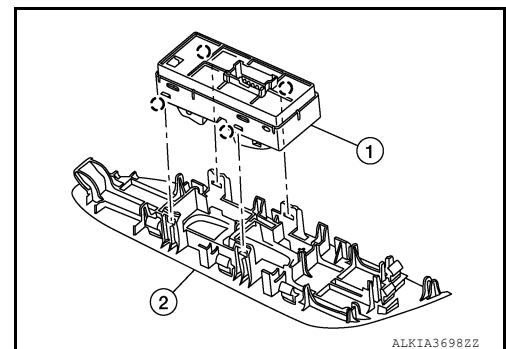

INSTALLATION

Installation is in the reverse order of removal.

NOTE:

When power window and door lock/unlock switch RH is removed or replaced, it is necessary to perform initialization procedure. Refer to [PWC-32. "Work Procedure"](#).

REAR POWER WINDOW SWITCH

< REMOVAL AND INSTALLATION >

REAR POWER WINDOW SWITCH

Removal and Installation

INFOID:000000011218423

REMOVAL

1. Pull armrest in direction shown (←) then starting at rear release rear power window switch finisher (1) pawls using a suitable tool (A).

←: Front

○: Pawl

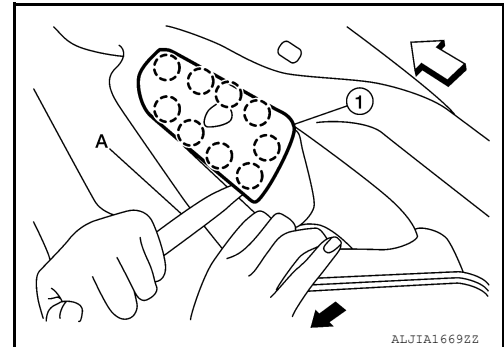

2. Disconnect the harness connector from the rear power window switch and remove.
3. Release the pawls then separate the rear power window switch (1) from the switch finisher (2).

○: Pawl

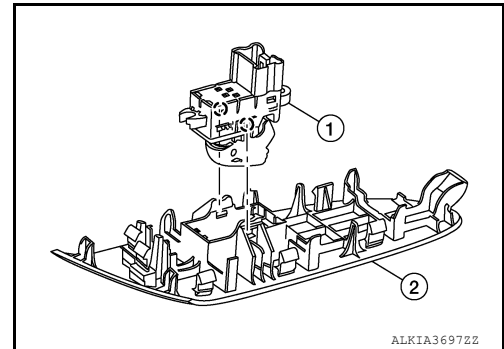

INSTALLATION

Installation is in the reverse order of removal.

A
B
C
D
E
F
G
H
I
J
L
M
N
O
P

PWC