

WT  
**SECTION**  
**ROAD WHEELS & TIRES**

A  
B  
C  
D

WT

**CONTENTS**

<p><b>PRECAUTION</b> ..... 3</p> <p><b>PRECAUTIONS</b> ..... 3</p> <p style="padding-left: 20px;">Precaution for Supplemental Restraint System (SRS) "AIR BAG" and "SEAT BELT PRE-TENSIONER" .....3</p> <p style="padding-left: 20px;">Service Notice and Precautions for TPMS .....3</p> <p style="padding-left: 20px;">Service Notice and Precautions for Road Wheel .....3</p> <p><b>PREPARATION</b> ..... 5</p> <p><b>PREPARATION</b> ..... 5</p> <p style="padding-left: 20px;">Special Service Tool .....5</p> <p style="padding-left: 20px;">Commercial Service Tool .....5</p> <p><b>SYSTEM DESCRIPTION</b> ..... 6</p> <p><b>COMPONENT PARTS</b> ..... 6</p> <p style="padding-left: 20px;">Component Parts Location .....6</p> <p style="padding-left: 20px;">BCM .....7</p> <p style="padding-left: 20px;">Tire Pressure Sensor .....7</p> <p style="padding-left: 20px;">Remote Keyless Entry Receiver (Tire Pressure Receiver) .....8</p> <p style="padding-left: 20px;">Outside Key Antennas .....8</p> <p><b>SYSTEM</b> ..... 9</p> <p style="padding-left: 20px;">System Description .....9</p> <p style="padding-left: 20px;">Easy Fill Tire Alert Function ..... 11</p> <p><b>DIAGNOSIS SYSTEM (BCM)</b> .....12</p> <p><b>COMMON ITEM</b> ..... 12</p> <p style="padding-left: 20px;">COMMON ITEM : CONSULT Function (BCM - COMMON ITEM) ..... 12</p> <p><b>AIR PRESSURE MONITOR</b> ..... 13</p> <p style="padding-left: 20px;">AIR PRESSURE MONITOR : CONSULT Function (BCM-AIR PRESSURE MONITOR) ..... 13</p> <p><b>DIAGNOSIS SYSTEM (TIRE PRESSURE MONITORING SYSTEM)</b> .....15</p> <p style="padding-left: 20px;">CONSULT Function ..... 15</p>	<p><b>ECU DIAGNOSIS INFORMATION</b> .....17</p> <p><b>BCM</b> .....17</p> <p style="padding-left: 20px;">List of ECU Reference .....17</p> <p><b>WIRING DIAGRAM</b> ..... 18</p> <p><b>TIRE PRESSURE MONITORING SYSTEM</b> ..... 18</p> <p style="padding-left: 20px;">Wiring Diagram .....18</p> <p><b>BASIC INSPECTION</b> .....23</p> <p><b>DIAGNOSIS AND REPAIR WORK FLOW</b> .....23</p> <p style="padding-left: 20px;">Work Flow .....23</p> <p><b>ID REGISTRATION PROCEDURE</b> .....25</p> <p style="padding-left: 20px;">Description .....25</p> <p style="padding-left: 20px;">Work Procedure .....25</p> <p><b>CONFIGURATION (TIRE PRESSURE MONITORING SYSTEM)</b> .....28</p> <p style="padding-left: 20px;">Work Procedure .....28</p> <p><b>DTC/CIRCUIT DIAGNOSIS</b> .....30</p> <p><b>C1704, C1705, C1706, C1707 LOW TIRE PRESSURE</b> .....30</p> <p style="padding-left: 20px;">DTC Description .....30</p> <p style="padding-left: 20px;">Diagnosis Procedure .....31</p> <p><b>C1708, C1709, C1710, C1711 TIRE PRESSURE SENSOR</b> .....32</p> <p style="padding-left: 20px;">DTC Description .....32</p> <p style="padding-left: 20px;">Diagnosis Procedure .....33</p> <p><b>C1716, C1717, C1718, C1719 TIRE PRESSURE SENSOR</b> .....36</p> <p style="padding-left: 20px;">DTC Description .....36</p> <p style="padding-left: 20px;">Diagnosis Procedure .....37</p> <p><b>C1729 VEHICLE SPEED SIGNAL</b> .....38</p> <p style="padding-left: 20px;">DTC Description .....38</p> <p style="padding-left: 20px;">Diagnosis Procedure .....38</p>
---	---

F  
G  
H  
I  
J  
K  
L  
M  
N  
O  
P

<b>C1730, C1731, C1732, C1733 FLAT TIRE</b> .....	<b>40</b>	<b>LOW TIRE PRESSURE WARNING LAMP</b>	
DTC Description .....	40	<b>BLINKS</b> .....	<b>59</b>
Diagnosis Procedure .....	41	Description .....	59
<b>C1734 CONTROL UNIT</b> .....	<b>42</b>	Diagnosis Procedure .....	59
DTC Description .....	42	<b>EASY FILL TIRE ALERT DOES NOT ACTI-</b>	
Diagnosis Procedure .....	42	<b>VATE</b> .....	<b>60</b>
<b>C1735 IGNITION SIGNAL</b> .....	<b>44</b>	Description .....	60
DTC Logic .....	44	Diagnosis Procedure .....	60
Diagnosis Procedure .....	44	<b>ID REGISTRATION CANNOT BE COMPLET-</b>	
<b>C1761, C1762, C1763, C1764 TIRE PRES-</b>		<b>ED</b> .....	<b>62</b>
<b>SURE SENSOR</b> .....	<b>46</b>	Description .....	62
DTC Description .....	46	Diagnosis Procedure .....	62
Diagnosis Procedure .....	46	<b>NOISE, VIBRATION AND HARSHNESS</b>	
<b>C1769 CONFIGURATION SETTING</b> .....	<b>48</b>	<b>(NVH) TROUBLESHOOTING</b> .....	<b>63</b>
DTC Description .....	48	NVH Troubleshooting Chart .....	63
Diagnosis Procedure .....	48	<b>PERIODIC MAINTENANCE</b> .....	<b>64</b>
<b>C1770, C1771, C1772, C1773 G SENSOR</b> .....	<b>50</b>	<b>WHEEL</b> .....	<b>64</b>
DTC Description .....	50	Inspection .....	64
Diagnosis Procedure .....	51	<b>WHEEL AND TIRE</b> .....	<b>65</b>
<b>U1000 CAN COMM CIRCUIT</b> .....	<b>52</b>	Balancing Wheels .....	65
Description .....	52	Rotation .....	66
Diagnosis Procedure .....	52	<b>REMOVAL AND INSTALLATION</b> .....	<b>68</b>
<b>U1010 CONTROL UNIT (CAN)</b> .....	<b>53</b>	<b>WHEEL AND TIRE</b> .....	<b>68</b>
Description .....	53	Exploded View .....	68
Diagnosis Procedure .....	53	Removal and Installation .....	68
<b>LOW TIRE PRESSURE WARNING LAMP</b> .....	<b>54</b>	<b>TIRE PRESSURE SENSOR</b> .....	<b>69</b>
Component Function Check .....	54	Exploded View .....	69
Diagnosis Procedure .....	54	Removal and Installation .....	69
<b>SYMPTOM DIAGNOSIS</b> .....	<b>55</b>	Disposal .....	72
<b>TPMS</b> .....	<b>55</b>	<b>REMOTE KEYLESS ENTRY RECEIVER</b> .....	<b>73</b>
Symptom Table .....	55	Removal and Installation .....	73
<b>LOW TIRE PRESSURE WARNING LAMP</b>		<b>SERVICE DATA AND SPECIFICATIONS</b>	
<b>DOES NOT TURN ON</b> .....	<b>57</b>	<b>(SDS)</b> .....	<b>74</b>
Low Tire Pressure Warning Lamp Does Not Come		<b>SERVICE DATA AND SPECIFICATIONS</b>	
On When Ignition Switch Is Turned On .....	57	<b>(SDS)</b> .....	<b>74</b>
<b>LOW TIRE PRESSURE WARNING LAMP</b>		Wheel .....	74
<b>STAYS ON</b> .....	<b>58</b>	Tire Air Pressure .....	74
Low Tire Pressure Warning Lamp Stays On When			
Ignition Switch Is Turned On .....	58		

# PRECAUTIONS

< PRECAUTION >

## PRECAUTION

### PRECAUTIONS

#### Precaution for Supplemental Restraint System (SRS) "AIR BAG" and "SEAT BELT PRE-TENSIONER"

INFOID:000000011241691

The Supplemental Restraint System such as "AIR BAG" and "SEAT BELT PRE-TENSIONER", used along with a front seat belt, helps to reduce the risk or severity of injury to the driver and front passenger for certain types of collision. Information necessary to service the system safely is included in the SR and SB section of this Service Manual.

#### **WARNING:**

- To avoid rendering the SRS inoperative, which could increase the risk of personal injury or death in the event of a collision which would result in air bag inflation, all maintenance must be performed by an authorized NISSAN/INFINITI dealer.
- Improper maintenance, including incorrect removal and installation of the SRS, can lead to personal injury caused by unintentional activation of the system. For removal of Spiral Cable and Air Bag Module, see the SR section.
- Do not use electrical test equipment on any circuit related to the SRS unless instructed to in this Service Manual. SRS wiring harnesses can be identified by yellow and/or orange harnesses or harness connectors.

#### PRECAUTIONS WHEN USING POWER TOOLS (AIR OR ELECTRIC) AND HAMMERS

#### **WARNING:**

- When working near the Airbag Diagnosis Sensor Unit or other Airbag System sensors with the Ignition ON or engine running, DO NOT use air or electric power tools or strike near the sensor(s) with a hammer. Heavy vibration could activate the sensor(s) and deploy the air bag(s), possibly causing serious injury.
- When using air or electric power tools or hammers, always switch the Ignition OFF, disconnect the battery and wait at least three minutes before performing any service.

#### Service Notice and Precautions for TPMS

INFOID:000000011241692

#### **WARNING:**

Radio waves could adversely affect electric medical equipment. Those who use a pacemaker should contact the electric medical equipment manufacturer for the possible influences before use.

- Low tire pressure warning lamp blinks for 1 minute, then turns ON when occurring any malfunction except low tire pressure. Erase the self-diagnosis memories for Tire Pressure Monitoring System (TPMS), or register the ID to turn low tire pressure warning lamp OFF. For ID registration, refer to [WT-23, "Work Flow"](#).
- ID registration is required when replacing or rotating wheels, replacing tire pressure sensor or low tire pressure warning control unit. Refer to [WT-25, "Work Procedure"](#).
- Replace grommet seal, valve core and valve cap of tire pressure sensor in TPMS, when replacing each tire by reaching the wear limit. Refer to [WT-69, "Removal and Installation"](#).
- Never install tire pressure sensor from other vehicles. Tire pressure monitoring system (TPMS) does not function if specified Genuine NISSAN tire pressure sensor is not installed.
- Because the tire pressure sensor conforms to North America radio law, the following items must be observed.
  - The sensor may be used only in North America.
  - It may not be used in any method other than the specified method.
  - It must not be disassembled or modified.

#### Service Notice and Precautions for Road Wheel

INFOID:000000011241693

- Genuine NISSAN aluminum wheel is designed for each type of vehicle. Use it on the specified vehicle only.
- Use Genuine NISSAN parts for the road wheels, valve caps and wheel nuts.
- Always use them after adjusting the wheel balance. For the balance weights, use Genuine NISSAN aluminum wheel weights.
- Use caution when handling the aluminum wheels, because they can be easily scratched. When removing dirt, do not use any abrasives, a wire brush, or other items that may scratch the coating. Use a neutral detergent if a detergent is needed.
- After driving on roads scattered with anti-icing salts, wash off the wheels completely.

A

B

C

D

WT

F

G

H

I

J

K

L

M

N

O

P

## PRECAUTIONS

### < PRECAUTION >

---

- When installing road wheels onto the vehicle, always wipe off any dirt or foreign substances to prevent them from being trapped between the contact surfaces of wheel.
- Do not apply oil to nut and bolt threads.
- When tightening the valve cap there is a risk of damaging the valve cap if a tool is used. Tighten by hand.

# PREPARATION

< PREPARATION >



## PREPARATION

### PREPARATION

#### Special Service Tool

INFOID:000000011241694

The actual shape of the tools may differ from those illustrated here.

Tool number (TechMate No.) Tool name	Description
<p>— (J-50190) Signal Tech II</p>  <p>ALEIA01312Z</p>	<ul style="list-style-type: none"> <li>• Activate and display TPMS transmitter IDs</li> <li>• Display tire pressure reported by the TPMS transmitter</li> <li>• Read TPMS DTCs</li> <li>• Register TPMS transmitter IDs</li> <li>• Test remote keyless entry key fob relative signal strength</li> <li>• Check Intelligent Key relative signal strength</li> <li>• Confirm vehicle Intelligent Key antenna signal strength</li> <li>• Compatible with future sensors</li> <li>• Equipped with a display</li> </ul>
<p>KV48105501 (J-45295-A) Transmitter activation tool</p>  <p>ALEIA01832Z</p>	<ul style="list-style-type: none"> <li>• Activate TPMS transmitter IDs</li> <li>• Compatible with future sensors</li> <li>• Equipped with a display (KV48105501 only)</li> </ul>

#### Commercial Service Tool

INFOID:000000011241695

Tool name	Description
<p>Power tool</p>  <p>PIIB1407E</p>	<p>Loosening nuts, screws and bolts</p>

A  
B  
C  
D  
WT  
F  
G  
H  
I  
J  
K  
L  
M  
N  
O  
P

# COMPONENT PARTS

< SYSTEM DESCRIPTION >

## SYSTEM DESCRIPTION

### COMPONENT PARTS

#### Component Parts Location

INFOID:000000011552620

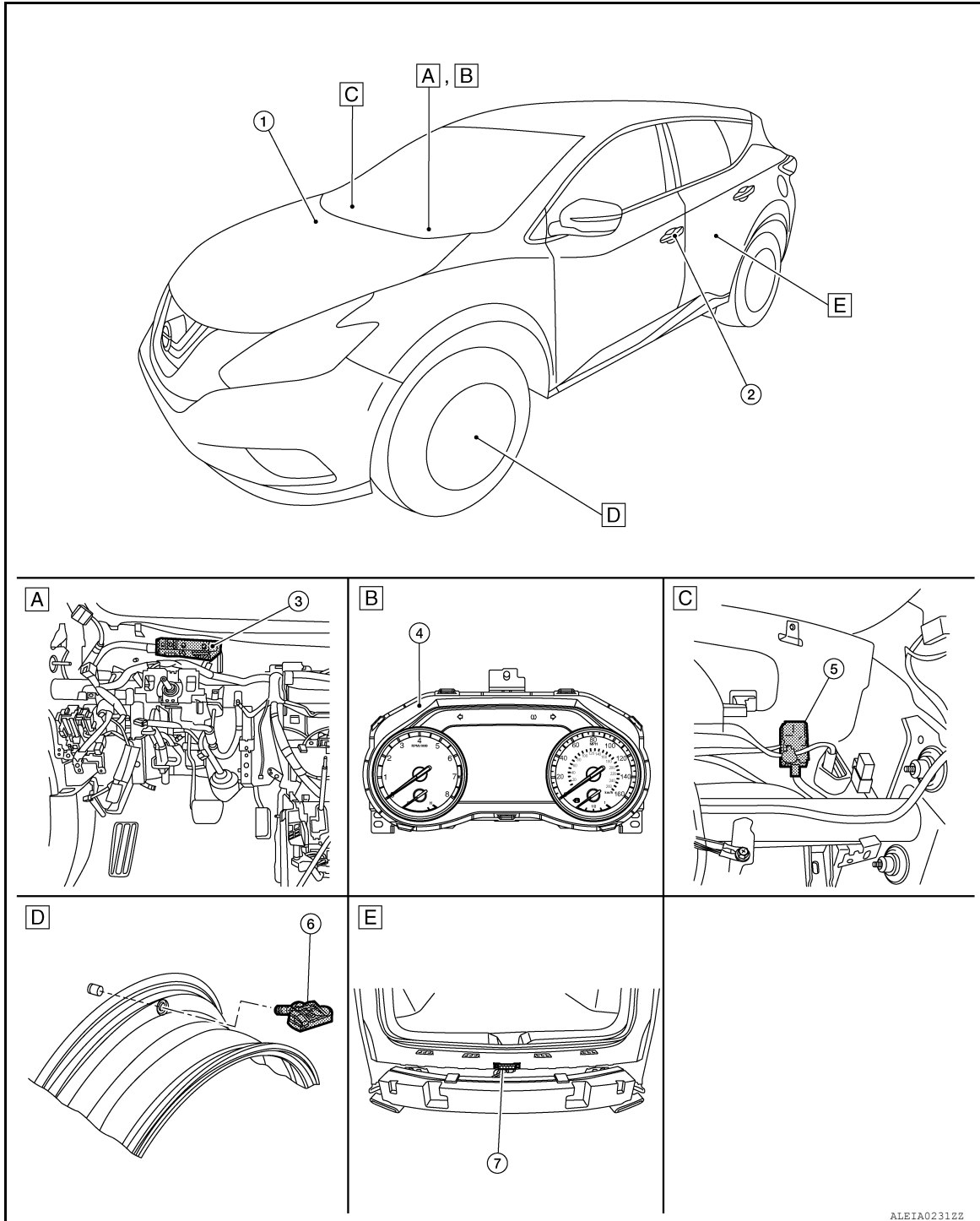

A. LH side of instrument panel  
(view with instrument panel removed)

B. Combination meter

C. RH side of instrument panel  
(view with instrument panel removed)

D. Wheel

E. View with rear bumper fascia removed

# COMPONENT PARTS

## < SYSTEM DESCRIPTION >

No.	Component parts	Function
1.	ABS actuator and electric unit (control unit)	Mainly transmits the vehicle speed signal to BCM via CAN communication.
2.	Front outside handle assembly LH [outside key antenna (RH side similar)]	Refer to <a href="#">WT-8, "Outside Key Antennas"</a> .
3.	BCM	Refer to <a href="#">WT-7, "BCM"</a> .
4.	Combination meter	Mainly receives the following signals from BCM via CAN communication: <ul style="list-style-type: none"> <li>• Low tire pressure warning lamp signal</li> <li>• TPMS malfunction warning lamp signal</li> <li>• Tire pressure data signal</li> <li>• Buzzer output signal</li> </ul> The combination meter will display the low tire pressure warning lamp when a low tire pressure or system malfunction is detected by the BCM. A warning message will also be displayed in the information display.
5.	Remote keyless entry receiver (tire pressure receiver)	Refer to <a href="#">WT-8, "Remote Keyless Entry Receiver (Tire Pressure Receiver)"</a> .
6.	Tire pressure sensor	Refer to <a href="#">WT-7, "Tire Pressure Sensor"</a> .
7.	Outside key antenna (rear bumper)	Refer to <a href="#">WT-8, "Outside Key Antennas"</a> .

### BCM

INFOID:000000011552621

The BCM reads the tire pressure signal received by the remote keyless entry receiver (tire pressure receiver). In addition, the BCM also uses the outside key antennas (driver side, passenger side and rear bumper) to identify the location of the tire pressure sensors. The BCM has a self-diagnosis function used to detect system malfunctions.

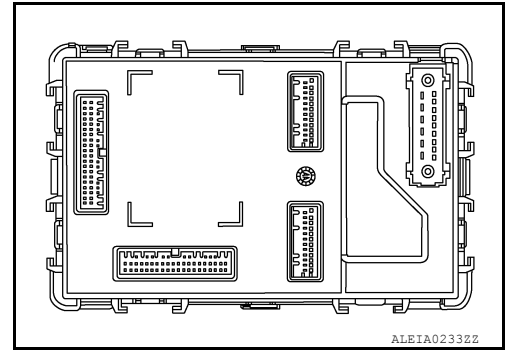

### Tire Pressure Sensor

INFOID:000000011552622

A tire pressure sensor (1) integrated with a valve is installed in each wheel (2), and transmits a detected air pressure signal in the form of a radio wave. The radio signal is received by the remote keyless entry receiver (tire pressure receiver).

← : Outside

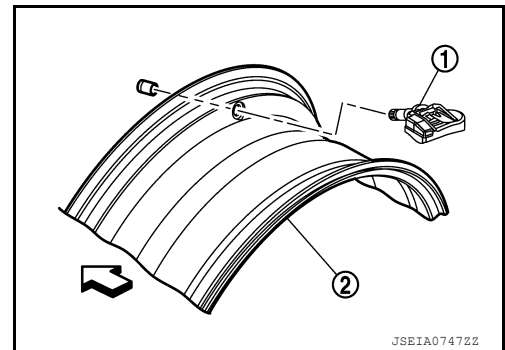

# COMPONENT PARTS

## < SYSTEM DESCRIPTION >

### Remote Keyless Entry Receiver (Tire Pressure Receiver)

INFOID:000000011552623

The remote keyless entry receiver receives (tire pressure receivers) the tire pressure signal transmitted by the tire pressure sensor in each wheel.

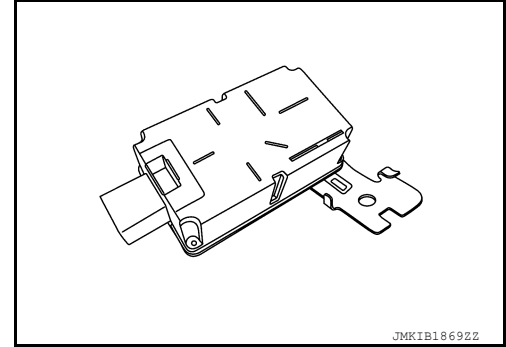

### Outside Key Antennas

INFOID:000000011552624

- For vehicles equipped with individual tire pressure display in the combination meter, the outside key antennas (driver side, passenger side and rear bumper) are used by the BCM to identify the location of the tire pressure sensor.
- Outside key antenna (driver side) and outside key antenna (passenger side) is installed in outside handle.

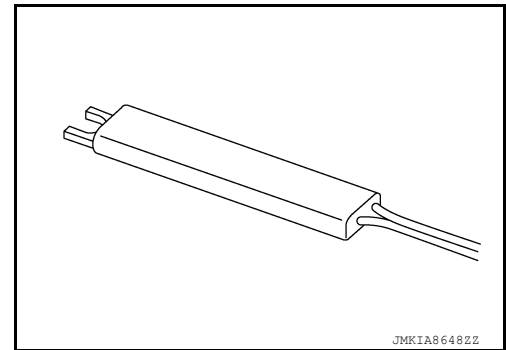

- Outside key antenna (rear bumper) is installed in the rear of rear bumper.

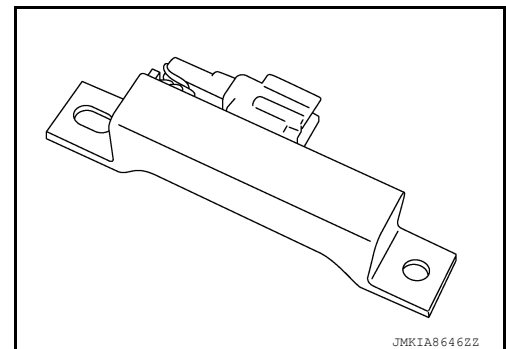



# SYSTEM

< SYSTEM DESCRIPTION >

## SYSTEM

### System Description

INFOID:000000011373014

When the vehicle has reached a speed of 40 km/h (25 MPH) or greater, the BCM receives a signal transmitted from the tire pressure sensors/transmitters installed in each wheel. If the BCM detects low inflation pressure or a system malfunction, it sends a signal to the combination meter via CAN communication to illuminate the low tire pressure warning lamp. In addition, a warning message will be displayed in the vehicle information display. Refer to the Owner's Manual for additional information.

The tire pressure monitoring system (TPMS) has a Easy fill tire alert function to aid in tire inflation. Refer to [WT-11, "Easy Fill Tire Alert Function"](#).

### SYSTEM DIAGRAM

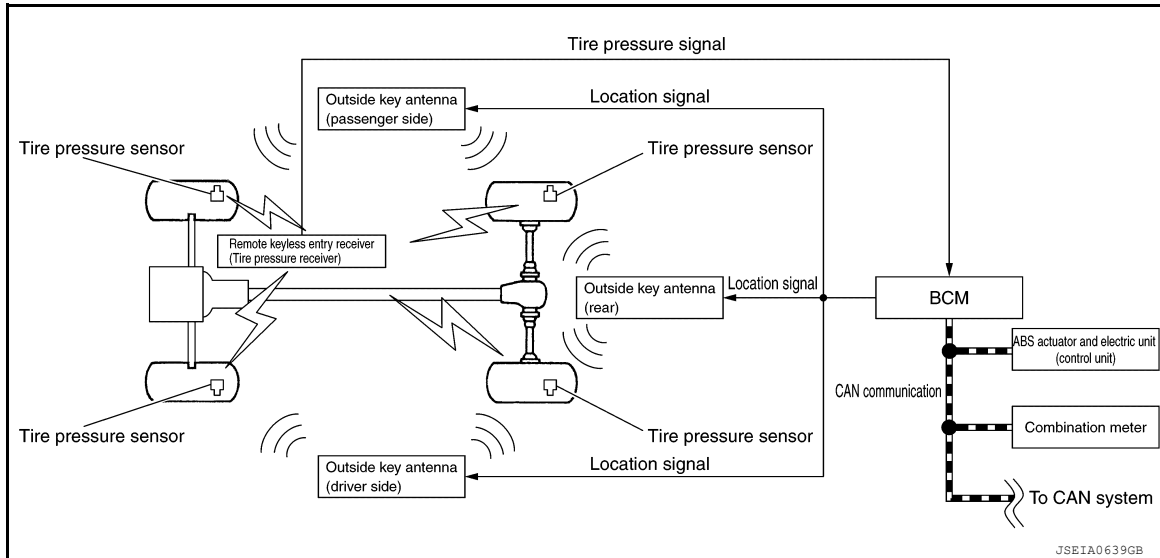

### INPUT SIGNAL AND OUTPUT SIGNAL

Major signal transmission between each unit via communication lines is shown in the following table.

Component	Signal description
Combination meter	Mainly receives the following signals from BCM via CAN communication: <ul style="list-style-type: none"> <li>• Low tire pressure warning lamp signal</li> <li>• TPMS malfunction warning lamp signal</li> <li>• Tire pressure data signal</li> <li>• Buzzer output signal</li> </ul> Transmits the vehicle speed signal via CAN communication for BCM.
ABS actuator and electric unit (control unit)	Transmits the vehicle speed signal via CAN communication for combination meter.

### LOW TIRE PRESSURE WARNING LAMP AND INFORMATION DISPLAY INDICATIONS

Uses CAN communication from the BCM to illuminate the low tire pressure warning lamp on the combination meter.

Name	Design	Layout
Low tire pressure warning lamp		Refer to <a href="#">MWI-6, "METER SYSTEM : Design"</a> .

Condition	Low tire pressure warning lamp	Information display
Ignition switch OFF	OFF	OFF
Ignition switch ON (system normal)	ON for 1 second then turns off	No TPMS message

# SYSTEM

## < SYSTEM DESCRIPTION >

Condition	Low tire pressure warning lamp	Information display
Low tire pressure	ON	<ul style="list-style-type: none"> <li>Flat Tire Visit dealer</li> <li>Tire Pressure Low Add Air</li> </ul>
Configuration not performed in tire pressure monitoring system	Blinks for 1 minute then stays ON	No TPMS message
Tire pressure sensor ID not registered in BCM		
TPMS malfunction		

### LOW TIRE PRESSURE LOCATION INDICATOR

The low tire pressure location indicator is displayed in the vehicle information display of the combination meter with the low tire pressure warning lamp and warning message under the following conditions:

- Tire pressure is low.
- TPMS detected a system malfunction.
- Tire pressure is extremely low (flat tire).

Symbol	Warning Message
 <p style="text-align: center; font-size: small;">JSEIA0664ZZ</p>	<ul style="list-style-type: none"> <li>Flat Tire Visit dealer</li> <li>Tire Pressure Low Add Air</li> </ul>

### TIRE PRESSURE DISPLAY

The adoption of this function allows tire pressure indication on the information display installed to the combination meter.

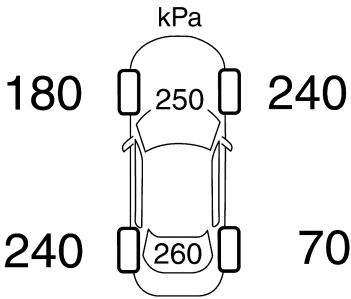
Design	Description
 <p style="text-align: center; font-size: small;">JSEIA0711ZZ</p>	<ul style="list-style-type: none"> <li>Tire pressure of each tire is displayed at side of each tire.</li> <li>Setting tire pressure of front and rear tires are displayed between front/rear tires.</li> </ul>

### HAZARD WARNING LAMP INDICATION CONDITION

The hazard warning lamp blinks when ID registration is completed. Refer to [WT-25, "Work Procedure"](#).

### BUZZER CONTROL CONDITION

The low tire pressure warning control unit transmits a buzzer request signal to BCM. Based on the signal, BCM sends a command to the combination meter to sound the buzzer.

The buzzer sounds under the following conditions:

- When wake-up of registered wheel has been completed. Refer to [WT-25, "Work Procedure"](#).
- When tire goes flat.

# SYSTEM

## < SYSTEM DESCRIPTION >

### Easy Fill Tire Alert Function

INFOID:000000011373015

#### NOTE:

When beginning tire inflation, it takes a few seconds for the Easy fill tire alert to function. If there is no response for approximately 15 seconds or more, cancel the Easy fill tire alert function and move the vehicle approximately 1 m (3.2 ft) backward or forward to try again.

- The Easy fill tire alert function operates only when the select lever position is in P-range with the ignition switch ON.
- This function informs the driver with a visual and audible indication that the recommended COLD tire pressure has been reached.
- The hazard warning lamps blink when the recommended COLD tire pressure has been reached. After the recommended COLD tire pressure has been reached, the horn sounds once and the hazard warning lamps stop blinking.
- If the tire pressure value is equal to or greater than 30 kPa (0.31 kg/cm<sup>2</sup>, 4 psi) more than the recommended COLD tire pressure, the hazard warning lamps flash and horn sounds three times.
- To return the tire to the recommended COLD tire pressure, deflate the tire until the horn sounds once and the hazard warning lamps stop blinking.

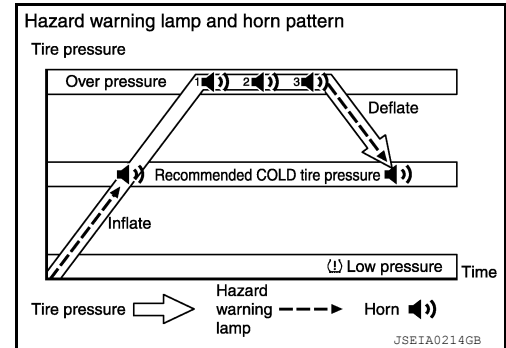

# DIAGNOSIS SYSTEM (BCM)

< SYSTEM DESCRIPTION >

## DIAGNOSIS SYSTEM (BCM) COMMON ITEM

COMMON ITEM : CONSULT Function (BCM - COMMON ITEM)

INFOID:000000011552750

### APPLICATION ITEM

CONSULT performs the following functions via CAN communication with BCM.

Direct Diagnostic Mode	Description
ECU Identification	The BCM part number is displayed.
Self Diagnostic Result	The BCM self diagnostic results are displayed.
Data Monitor	The BCM input/output data is displayed in real time.
Active Test	The BCM activates outputs to test components.
Work support	The settings for BCM functions can be changed.
Configuration	<ul style="list-style-type: none"> <li>The vehicle specification can be read and saved.</li> <li>The vehicle specification can be written when replacing BCM.</li> </ul>
CAN Diag Support Mntr	The result of transmit/receive diagnosis of CAN communication is displayed.

### SYSTEM APPLICATION

BCM can perform the following functions:

System	Sub System	Direct Diagnostic Mode						
		ECU Identification	Self Diagnostic Result	Data Monitor	Active Test	Work support	Configuration	CAN Diag Support Mntr
Door lock	DOOR LOCK		×	×	×	×		
Rear window defogger	REAR DEFOGGER			×	×	×		
Warning chime	BUZZER			×	×			
Interior room lamp timer	INT LAMP			×	×	×		
Exterior lamp	HEADLAMP			×	×	×		
Wiper and washer	WIPER			×	×	×		
Turn signal and hazard warning lamps	FLASHER			×	×	×		
Air conditioner	AIR CONDITIONER			×				
Intelligent Key system	INTELLIGENT KEY		×	×	×	×		
Combination switch	COMB SW			×				
BCM	BCM	×	×			×	×	×
Immobilizer	IMMU		×	×	×			
Interior room lamp battery saver	BATTERY SAVER			×	×			
Back door open	TRUNK			×				
Vehicle security system	THEFT ALM			×	×	×		
RAP system	RETAINED PWR			×				
Signal buffer system	SIGNAL BUFFER			×	×			
TPMS	AIR PRESSURE MONITOR		×	×	×			

### FREEZE FRAME DATA (FFD)

# DIAGNOSIS SYSTEM (BCM)

## < SYSTEM DESCRIPTION >

The BCM records the following vehicle condition at the time a particular DTC is detected, and displays it on CONSULT.

CONSULT screen item	Indication/Unit	Description
Vehicle Speed	km/h	Vehicle speed at the moment a particular DTC is detected
Odo/Trip Meter	km	Total mileage (Odometer value) at the moment a particular DTC is detected
Vehicle Condition	SLEEP>LOCK	While turning BCM status from low power consumption mode to normal mode (Power supply position is "LOCK"*).
	SLEEP>OFF	While turning BCM status from low power consumption mode to normal mode (Power supply position is "OFF".)
	LOCK>ACC	While turning power supply position from "LOCK"*to "ACC"
	ACC>ON	While turning power supply position from "ACC" to "IGN"
	RUN>ACC	While turning power supply position from "RUN" to "ACC" (Vehicle is stopped and selector lever is in P position.)
	CRANK>RUN	While turning power supply position from "CRANKING" to "RUN" (From cranking up the engine to run it)
	RUN>URGENT	While turning power supply position from "RUN" to "ACC" (Emergency stop operation)
	ACC>OFF	While turning power supply position from "ACC" to "OFF"
	OFF>LOCK	While turning power supply position from "OFF" to "LOCK"*
	OFF>ACC	While turning power supply position from "OFF" to "ACC"
	ON>CRANK	While turning power supply position from "IGN" to "CRANKING"
	OFF>SLEEP	While turning BCM status from normal mode (Power supply position is "OFF".) to low power consumption mode
	LOCK>SLEEP	While turning BCM status from normal mode (Power supply position is "LOCK"*. ) to low power consumption mode
	LOCK	Power supply position is "LOCK" (Ignition switch OFF)*
	OFF	Power supply position is "OFF" (Ignition switch OFF)
	ACC	Power supply position is "ACC" (Ignition switch ACC)
	ON	Power supply position is "IGN" (Ignition switch ON with engine stopped)
	ENGINE RUN	Power supply position is "RUN" (Ignition switch ON with engine running)
	CRANKING	Power supply position is "CRANKING" (At engine cranking)
IGN Counter	0 - 39	<p>The number of times that ignition switch is turned ON after DTC is detected</p> <ul style="list-style-type: none"> <li>• The number is 0 when a malfunction is detected now.</li> <li>• The number increases like 1 → 2 → 3...38 → 39 after returning to the normal condition whenever ignition is switched OFF → ON.</li> <li>• The number is fixed to 39 until the self-diagnosis results are erased if it is over 39.</li> </ul>

### NOTE:

\*: Power supply position shifts to "LOCK" from "OFF", when ignition switch is in the OFF position, selector lever is in the P position, and any of the following conditions are met:

- Closing door
- Opening door
- Door is locked using door request switch
- Door is locked using Intelligent Key

The power supply position shifts to "ACC" when the push-button ignition switch (push switch) is pushed at "LOCK".

## AIR PRESSURE MONITOR

### AIR PRESSURE MONITOR : CONSULT Function (BCM-AIR PRESSURE MONITOR)

INFOID:000000011552749

### NOTE:

# DIAGNOSIS SYSTEM (BCM)

## < SYSTEM DESCRIPTION >

The Signal Tech II Tool [— (J-50190)] can be used to perform the following functions. Refer to the Signal Tech II User Guide for additional information.

- Activate and display TPMS transmitter IDs
- Display tire pressure reported by the TPMS transmitter
- Read TPMS DTCs
- Register TPMS transmitter IDs
- Check Intelligent Key relative signal strength
- Confirm vehicle Intelligent Key antenna signal strength

## SELF DIAGNOSTIC RESULT

### NOTE:

Before performing Self Diagnostic Result, be sure to register the transmitter ID or the actual malfunction may be different from that displayed on CONSULT.

Refer to [BCS-52. "DTC Index"](#).

## DATA MONITOR

Monitor Item [Unit]	Description
AIR PRESS FL [kPa, kg/cm <sup>2</sup> or Psi]	Indicates air pressure of front LH tire.
AIR PRESS FR [kPa, kg/cm <sup>2</sup> or Psi]	Indicates air pressure of front RH tire.
AIR PRESS RR [kPa, kg/cm <sup>2</sup> or Psi]	Indicates air pressure of rear RH tire.
AIR PRESS RL [kPa, kg/cm <sup>2</sup> or Psi]	Indicates air pressure of rear LH tire.
ID REGST FL1 [Done/Yet]	Indicates ID registration status of front LH transmitter.
ID REGST FR1 [Done/Yet]	Indicates ID registration status of front RH transmitter.
ID REGST RR1 [Done/Yet]	Indicates ID registration status of rear RH transmitter.
ID REGST RL1 [Done/Yet]	Indicates ID registration status of rear LH transmitter.
WARNING LAMP [Off/On]	Indicates condition of low tire pressure warning lamp in combination meter.
BUZZER [Off/On]	Indicates condition of buzzer in combination meter.

## ACTIVE TEST

Test Item	Description
FLASHER	This test is able to check turn signal lamp operation [Off/LH/RH].
HORN	This test is able to check horn operation [On].

# DIAGNOSIS SYSTEM (TIRE PRESSURE MONITORING SYSTEM)

< SYSTEM DESCRIPTION >

## DIAGNOSIS SYSTEM (TIRE PRESSURE MONITORING SYSTEM)

### CONSULT Function

INFOID:0000000011552751

#### APPLICATION ITEM

CONSULT performs the following functions via CAN communication with BCM.

Diagnosis mode	Function Description
ECU identification	Parts number of BCM can be read.
Self Diagnostic Result	Retrieve DTC from ECU and display diagnostic items.
Self Diagnostic Result	Self-diagnostic results and freeze frame data can be read and erased quickly.*
Data Monitor	Monitor the input/output signal of the control unit in real time.
Work support	This mode enables a technician to adjust some devices faster and more accurately.
Active test	The BCM activates outputs to test components.
Re/programming, Configuration	<ul style="list-style-type: none"> <li>Read and save the vehicle specification (TYPE ID).</li> <li>Write the vehicle specification (TYPE ID) when replacing BCM.</li> </ul>

#### SELF DIAGNOSTIC RESULT

##### NOTE:

Before performing Self Diagnostic Result, be sure to register the tire pressure sensor ID or the actual malfunction may be different from that displayed on CONSULT.

Refer to [BCS-52, "DTC Index"](#).

#### FREEZE FRAME DATA (FFD)

The following vehicle status is recorded when DTC is detected and is displayed on CONSULT:

Item name	Display item
SET AIR PRESSURE 2 FL	Set air pressure 2 front left
SET AIR PRESSURE 2 FR	Set air pressure 2 front right
SET AIR PRESSURE 2 RR	Set air pressure 2 rear right
SET AIR PRESSURE 2 RL	Set air pressure 2 rear left
WARNING AIR PRESSURE FL	Warning air pressure front left
WARNING AIR PRESSURE FR	Warning air pressure front right
WARNING AIR PRESSURE RR	Warning air pressure rear right
WARNING AIR PRESSURE RL	Warning air pressure rear left
AIR PRESS FL	Air pressure front left
AIR PRESS RL	Air pressure front right
AIR PRESS RR	Air pressure rear right
AIR PRESS RL	Air pressure rear left
SET TEMPERATURE	Set temperature
TIRE TEMPERATURE FL	Tire temperature front left
TIRE TEMPERATURE FR	Tire temperature front right
TIRE TEMPERATURE RR	Tire temperature rear right
TIRE TEMPERATURE RL	Tire temperature rear left
IGN COUNTER (0 - 39)	<p>The number of times that ignition switch is turned ON after the DTC is detected is displayed.</p> <ul style="list-style-type: none"> <li>When "0" is displayed: It indicates that the system is presently malfunctioning.</li> <li>When except "0" is displayed: It indicates that system malfunction in the past is detected, but the system is presently normal.</li> </ul> <p><b>NOTE:</b> Each time when ignition switch is turned OFF to ON, numerical number increases in 1→2→3...38→39. When the operation number of times exceeds 39, the number do not increase and "39" is displayed until self diagnosis is erased.</p>

# DIAGNOSIS SYSTEM (TIRE PRESSURE MONITORING SYSTEM)

## < SYSTEM DESCRIPTION >

### DATA MONITOR

Monitor Item (Unit)	Description
VHCL SPEED SE (km/h or mph)	Indicates vehicle speed.
AIR PRESS FL (kPa, kgf/cm <sup>2</sup> or Psi)	Indicates air pressure of front LH tire.
AIR PRESS FR (kPa, kgf/cm <sup>2</sup> or Psi)	Indicates air pressure of front RH tire.
AIR PRESS RR (kPa, kgf/cm <sup>2</sup> or Psi)	Indicates air pressure of rear RH tire.
AIR PRESS RL (kPa, kgf/cm <sup>2</sup> or Psi)	Indicates air pressure of rear LH tire.
LOW TIRE PRESSURE W/L (Off/On)	Indicates condition of low tire pressure warning lamp in combination meter.
BUZZER 2 (Off/On)	Indicates condition of buzzer in combination meter.
HORN (Off/On)	Indicates condition of horn.
HAZARD (Off/On)	Indicates condition of hazard.
WARNING AIR PRESSURE FL (kPa, kgf/cm <sup>2</sup> or Psi)	Indicates warning air pressure front LH tire.
WARNING AIR PRESSURE FR (kPa, kgf/cm <sup>2</sup> or Psi)	Indicates warning air pressure front RH tire.
WARNING AIR PRESSURE RR (kPa, kgf/cm <sup>2</sup> or Psi)	Indicates warning air pressure rear RH tire.
WARNING AIR PRESSURE RL (kPa, kgf/cm <sup>2</sup> or Psi)	Indicates warning air pressure rear LH tire.

### WORK SUPPORT

Support Item	Description
ID REGIST	Refer to <a href="#">WT-25, "Description"</a> .

### ACTIVE TEST

Test Item	Description
ID REGIST WARNING	This test is able to check that the buzzer sounds or the low tire pressure warning lamp turns on.
WARNING LAMP	This test is able to check that the low tire pressure warning lamp turns on.
FLASHER	This test is able to check turn signal lamp operation.
HORN	This test is able to check horn operation [On].



# BCM

< ECU DIAGNOSIS INFORMATION >

## ECU DIAGNOSIS INFORMATION

BCM

List of ECU Reference

INFOID:0000000011373018

ECU	Reference
BCM	<a href="#">BCS-30. "Reference Value"</a>
	<a href="#">BCS-50. "Fail Safe"</a>
	<a href="#">BCS-51. "DTC Inspection Priority Chart"</a>
	<a href="#">BCS-52. "DTC Index"</a>

A

B

C

D

WT

F

G

H

I

J

K

L

M

N

O

P

# TIRE PRESSURE MONITORING SYSTEM

< WIRING DIAGRAM >

## WIRING DIAGRAM

### TIRE PRESSURE MONITORING SYSTEM

Wiring Diagram

INFOID:000000011373019

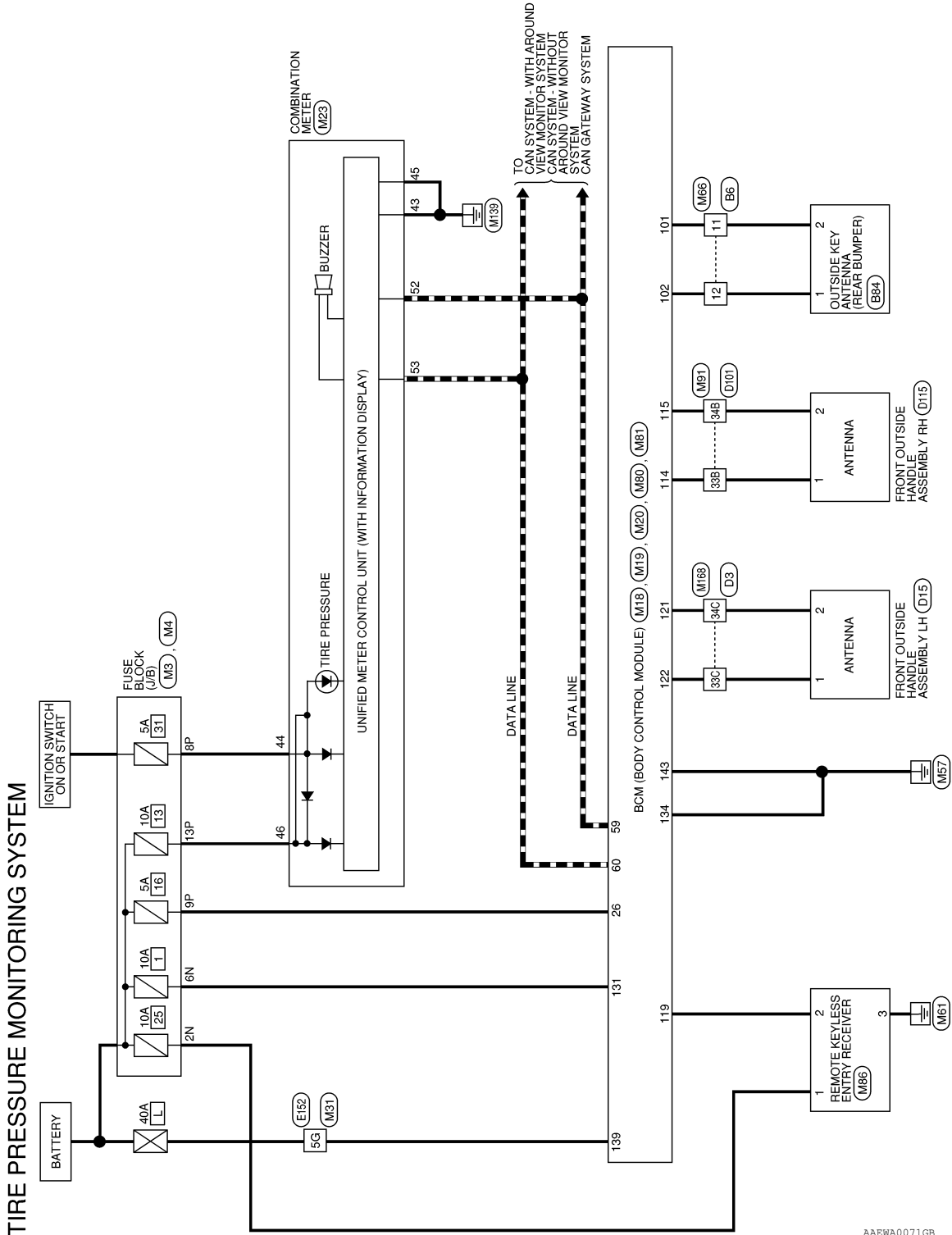

AAEWA0071GB

# TIRE PRESSURE MONITORING SYSTEM

< WIRING DIAGRAM >

## TIRE PRESSURE MONITORING SYSTEM CONNECTORS

Connector No.	M3
Connector Name	FUSE BLOCK (J/B)
Connector Color	WHITE

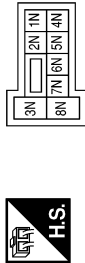

Connector No.	M4
Connector Name	FUSE BLOCK (J/B)
Connector Color	WHITE

Connector No.	M18
Connector Name	BCM (BODY CONTROL MODULE)
Connector Color	GREEN

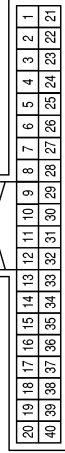

Terminal No.	Color of Wire	Signal Name
2N	BG	-
6N	W	-

Terminal No.	Color of Wire	Signal Name
8P	BG	-
9P	L	-
13P	W	-

Terminal No.	Color of Wire	Signal Name
26	L	SHORTING INPUT

Connector No.	M19
Connector Name	BCM (BODY CONTROL MODULE)
Connector Color	BLACK

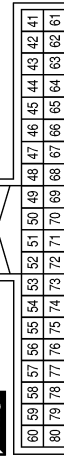

Terminal No.	Color of Wire	Signal Name
59	P	CAN-L
60	L	CAN-H

Connector No.	M20
Connector Name	BCM (BODY CONTROL MODULE)
Connector Color	GRAY



Terminal No.	Color of Wire	Signal Name
101	R	BACK DOOR ANTENNA B
102	G	BACK DOOR ANTENNA A

Connector No.	M23
Connector Name	COMBINATION METER
Connector Color	WHITE



Terminal No.	Color of Wire	Signal Name
43	B	GND1
44	BG	POWER (IGN)
45	B	GND2
46	W	POWER (BAT)
52	P	CAN-L
53	L	CAN-H

A B C D E F G H I J K L M N O P WT

# TIRE PRESSURE MONITORING SYSTEM

< WIRING DIAGRAM >

Connector No.	M66
Connector Name	WIRE TO WIRE
Connector Color	WHITE

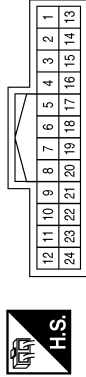

Terminal No.	Color of Wire	Signal Name
11	R	-
12	G	-

Terminal No.	5G	Color of Wire	L	Signal Name	-
--------------	----	---------------	---	-------------	---

Connector No.	M31
Connector Name	WIRE TO WIRE
Connector Color	WHITE

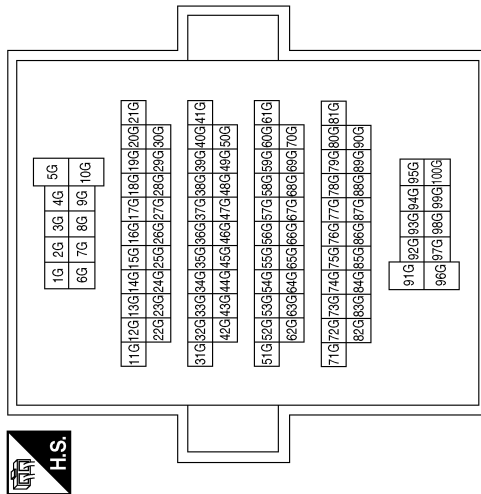

Connector No.	M86
Connector Name	REMOTE KEYLESS ENTRY RECEIVER
Connector Color	BLACK

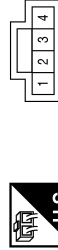

Terminal No.	Color of Wire	Signal Name
1	BG	-
2	R	-
3	B	-

Connector No.	M81
Connector Name	BCM (BODY CONTROL MODULE)
Connector Color	WHITE



Terminal No.	Color of Wire	Signal Name
131	W	BAT BCM FUSE
134	GR	GND 2
139	L	BAT POWER F/L
143	GR	GND 1

Connector No.	M80
Connector Name	BCM (BODY CONTROL MODULE)
Connector Color	BLACK

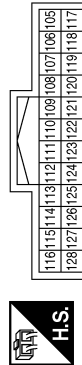

Terminal No.	Color of Wire	Signal Name
114	W	AS DOOR ANT A
115	BG	AS DOOR ANT B
119	R	RF NIMOCO
121	G	DR DOOR ANT B
122	GR	DR DOOR ANT A

AAE1A0181GB

# TIRE PRESSURE MONITORING SYSTEM

< WIRING DIAGRAM >

Connector No.	M168
Connector Name	WIRE TO WIRE
Connector Color	WHITE

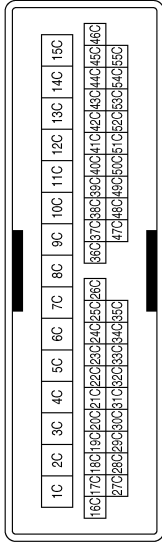

Terminal No.	Color of Wire	Signal Name
33C	GR	-
34C	G	-

Connector No.	M91
Connector Name	WIRE TO WIRE
Connector Color	WHITE

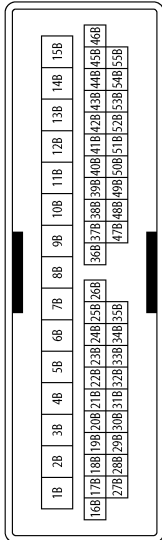

Terminal No.	Color of Wire	Signal Name
33B	W	-
34B	BG	-

Connector No.	B6
Connector Name	WIRE TO WIRE
Connector Color	WHITE



Terminal No.	Color of Wire	Signal Name
5G	P	-

Connector No.	E152
Connector Name	WIRE TO WIRE
Connector Color	WHITE

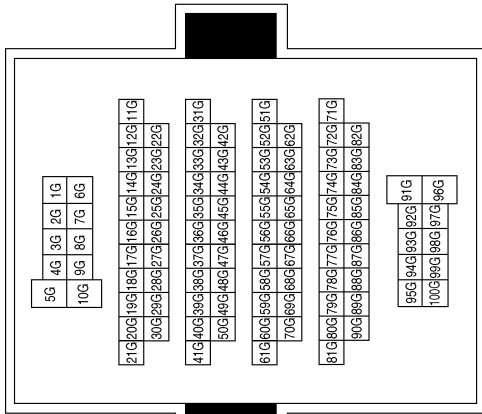

Terminal No.	Color of Wire	Signal Name
11	R	-
12	G	-

AAR1A0182GB

A  
B  
C  
D  
WT  
F  
G  
H  
I  
J  
K  
L  
M  
N  
O  
P

# TIRE PRESSURE MONITORING SYSTEM

< WIRING DIAGRAM >

Connector No.	B84
Connector Name	OUTSIDE KEY ANTENNA (REAR BUMPER)
Connector Color	GRAY



Connector No.	D3
Connector Name	WIRE TO WIRE
Connector Color	WHITE

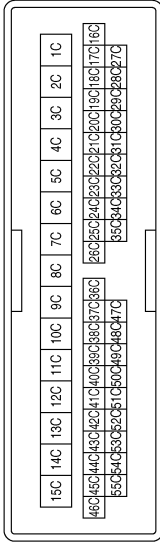

Terminal No.	Color of Wire	Signal Name
1	G	-
2	R	-

Connector No.	D15
Connector Name	FRONT OUTSIDE HANDLE ASSEMBLY LH
Connector Color	BLACK

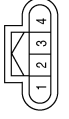

Terminal No.	Color of Wire	Signal Name
1	P	-
2	G	-

Connector No.	D101
Connector Name	WIRE TO WIRE
Connector Color	WHITE

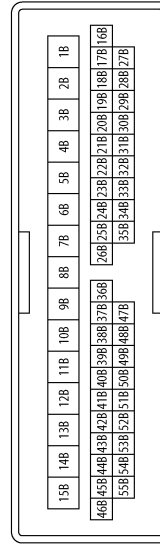

Terminal No.	Color of Wire	Signal Name
33B	G/W	-
34B	Y	-

Connector No.	D115
Connector Name	FRONT OUTSIDE HANDLE ASSEMBLY RH
Connector Color	BLACK



Terminal No.	Color of Wire	Signal Name
33C	P	-
34C	G	-

Terminal No.	Color of Wire	Signal Name
1	G/W	-
2	Y	-

AAEIA0183GB

# DIAGNOSIS AND REPAIR WORK FLOW

< BASIC INSPECTION >

## BASIC INSPECTION

### DIAGNOSIS AND REPAIR WORK FLOW

#### Work Flow

INFOID:000000011373020

#### NOTE:

The Signal Tech II Tool [– (J-50190)] can be used to perform the following functions. Refer to the Signal Tech II User Guide for additional information.

- Activate and display TPMS sensor IDs
- Display tire pressure reported by the TPMS sensor
- Read TPMS DTCs
- Register TPMS sensor IDs

#### 1. COLLECT INFORMATION FROM CUSTOMER

Get detailed information from the customer about the symptom (the condition and the environment when the incident/malfunction occurred).

>> GO TO 2.

#### 2. TIRE AND WHEEL INSPECTION

Check all tires and wheels for physical damage. Refer to [WT-64, "Inspection"](#).

Is the inspection result normal?

YES >> GO TO 3.

NO >> Repair or replace as necessary.

#### 3. TIRE PRESSURE INSPECTION

Check the tire pressure for all wheels. Refer to [WT-74, "Tire Air Pressure"](#).

Is the inspection result normal?

YES >> GO TO 4.

NO >> Check tire(s), wheel(s) and valve stem(s) for air leaks. Repair or replace as necessary.

#### 4. CHECK LOW TIRE PRESSURE WARNING LAMP

Check that the low tire pressure warning lamp illuminates for approximately 1 second after the ignition switch is turned ON, then turns OFF.

Does the low tire pressure warning lamp turn OFF?

YES >> Inspection End.

NO >> GO TO 5.

#### 5. PERFORM SELF DIAGNOSTIC RESULT

Perform self diagnostic result. Refer to [WT-13, "AIR PRESSURE MONITOR : CONSULT Function \(BCM-AIR PRESSURE MONITOR\)"](#).

Are any DTCs displayed?

YES >> Refer to [BCS-52, "DTC Index"](#). If two or more DTCs are displayed, refer to [BCS-51, "DTC Inspection Priority Chart"](#).

NO >> GO TO 6.

#### 6. PERFORM DIAGNOSIS APPLICABLE TO THE SYMPTOM

Perform diagnosis applicable to the symptom. Refer to [WT-55, "Symptom Table"](#).

>> GO TO 7.

#### 7. FINAL CHECK

Perform self diagnostic result again, and check that the malfunction is repaired. After checking, erase the self diagnosis memory. Refer to [WT-13, "AIR PRESSURE MONITOR : CONSULT Function \(BCM-AIR PRESSURE MONITOR\)"](#).

## DIAGNOSIS AND REPAIR WORK FLOW

< BASIC INSPECTION >

---

>> Inspection End.



# ID REGISTRATION PROCEDURE

< BASIC INSPECTION >

## ID REGISTRATION PROCEDURE

### Description

INFOID:0000000011373021

This procedure must be performed after replacement of a tire pressure sensor or BCM.

### Work Procedure

INFOID:0000000011373022

TPMS ID registration can be performed using one of the following procedures:

- Transmitter Activation tool [KV48105501 (J-45295-A)] using CONSULT (preferred method)
- Signal Tech II tool [- (J-50190)] with CONSULT (preferred method)
- Signal Tech II tool [- (J-50190)] without CONSULT
- CONSULT only

### TPMS REGISTRATION WITH TRANSMITTER ACTIVATION TOOL [KV48105501 (J-45295-A)]

#### With CONSULT

1. Turn the ignition switch ON.
2. Using CONSULT, select "Work support" in "AIR PRESSURE MONITOR" of "BCM". Then, select "ID REG-IST."
3. Select "Start" on "ID REGIST" screen.
4. Hold the transmitter activation tool [- (J-45295-A)] (1) against the side of the left front tire, near the valve stem.
5. With the tool held at a 0 to 15 degree angle to the tire, press and hold the transmitter activation tool button until the indicator lamp turns OFF (approximately 5 seconds).
6. Repeat steps 4 and 5 for the remaining tires in this order: right front, right rear and left rear.

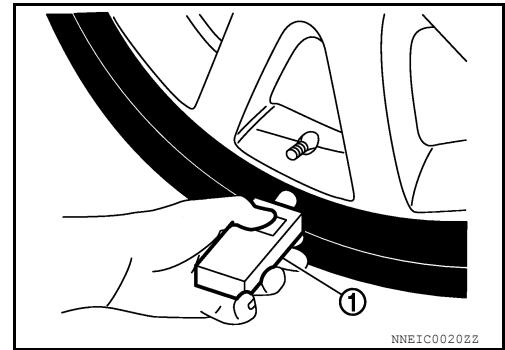

7. When ID registration is complete, check the following pattern at each wheel.

Sequence	ID registration position	Turn signal lamp	CONSULT
1	Front LH	2 blinks	"Yet (red)" ↓ "Done (green)"
2	Front RH		
3	Rear RH		
4	Rear LH		

8. After the ID registration procedure for all wheels is complete, press "End" on the CONSULT to finish ID registration.
9. Test drive the vehicle to ensure that the TPMS lamp is OFF and no warning messages are present.

### TPMS REGISTRATION WITH SIGNAL TECH II TOOL [- (J-50190)]

#### NOTE:

The Signal Tech II must be updated with the newest software version in order to perform the below procedures. The Signal Tech II software updates can only be downloaded from a CONSULT unit with ASIST. Other versions of ASIST will not show the updates.

#### With CONSULT

1. Adjust the tire pressure for all tires to the recommended value. Refer to [WT-74, "Tire Air Pressure"](#).
2. Turn the ignition switch ON.
3. Using CONSULT, select "Work support" in "AIR PRESSURE MONITOR" of "BCM". Then, select "ID REG-IST."
4. Select "Start" on "ID REGIST" screen.
5. Turn on the Signal Tech II tool [- (J-50190)].

# ID REGISTRATION PROCEDURE

## < BASIC INSPECTION >

6. Hold the Signal Tech II against the side of the left front tire, near the valve stem.
7. With the tool held at a 0 to 15 degree angle to the tire, select "Activate Sensor" from the main menu, then press and release the "OK" button to activate the sensor. Once the sensor is activated, the vehicle parking lamps will flash and the sensor ID will appear on the CONSULT screen.
8. Repeat steps 6 and 7 for the remaining tires in this order: right front, right rear and left rear.
9. When ID registration is complete, check the following pattern at each wheel.

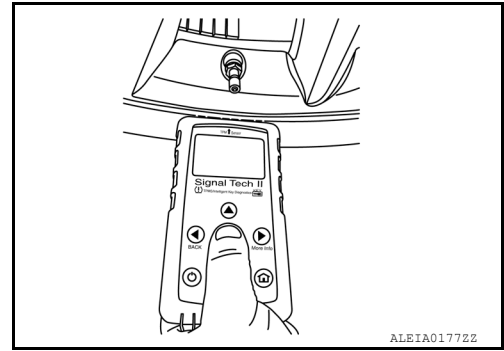

Sequence	ID registration position	Turn signal lamp	CONSULT
1	Front LH	2 blinks	"Yet (red)" ↓ "Done (green)"
2	Front RH		
3	Rear RH		
4	Rear LH		

10. Once all sensors have been activated, select "End" on the CONSULT to finish ID registration.
11. Test drive the vehicle to ensure that the TPMS lamp is OFF and no warning messages are present.

### ⊗ Without CONSULT

1. Adjust the tire pressure for all tires to the recommended value. Refer to [WT-74, "Tire Air Pressure"](#).
2. Turn on the Signal Tech II tool [- (J-50190)] and select "TPMS Check" from the main menu.
3. Select vehicle model and year.
4. When prompted, hold the Signal Tech II against the side of the left front tire, near the valve stem.
5. With the tool held at a 0 to 15 degree angle to the tire, press and release the "OK" button to activate the sensor. Once the sensor is activated, the tool will sound a tone and the tire pressure will be displayed.
6. Repeat steps 4 and 5 for the remaining tires in this order: right front, right rear and left rear.
7. When prompted, connect the tool to the data link connector. The tool will connect to the BCM, read the VIN, read sensor IDs and check for TPMS DTCs. Along with DTCs detected, one of the following will be displayed next to each wheel:
  - N/A - Not applicable because no ID found by the tool
  - OK - Wheel and sensor are in original position
  - NEW - New ID found compared to BCM
  - RT - Wheel has been rotated
  - Low Press - Low tire pressure
8. If no DTC is present or the repair has been completed, press the "OK" button to register the IDs and clear DTCs.
9. Test drive the vehicle to ensure that the TPMS lamp is OFF and no warning messages are present.
10. Print a Signal Tech II Audit Report for your records. Refer to the Signal Tech II User Guide for instructions.

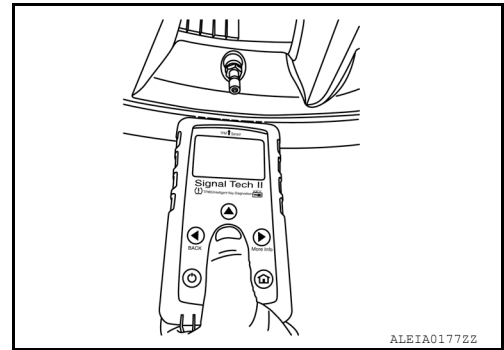

## TPMS REGISTRATION WITH CONSULT ONLY

### Ⓟ With CONSULT

1. Adjust the tire pressure for all wheels to match the list below.

Tire position	Tire pressure kPa (kg/cm <sup>2</sup> , psi)
Front LH	240 (2.4, 35)
Front RH	220 (2.2, 32)
Rear RH	200 (2.0, 29)
Rear LH	180 (1.8, 26)

## ID REGISTRATION PROCEDURE

### < BASIC INSPECTION >

2. Turn the ignition switch ON.
3. Using CONSULT, select "Work support" in "AIR PRESSURE MONITOR" of "BCM". Then, select "ID REG-IST."
4. Select "Start" on "ID REGIST" screen.
5. Drive the vehicle at a speed greater than 40 km/h (25 MPH) for 3 minutes or more.
6. After ID registration for all wheels is complete, press "End" on the CONSULT to finish ID registration.

ID registration position	CONSULT
Front LH	"Yet (red)" ↓ "Done (green)"
Front RH	
Rear RH	
Rear LH	

7. Adjust the tire pressures for all tires to the recommended value. Refer to [WT-74, "Tire Air Pressure"](#).
8. Test drive the vehicle to ensure that the TPMS lamp is OFF and no warning messages are present.

A  
B  
C  
D  
WT  
F  
G  
H  
I  
J  
K  
L  
M  
N  
O  
P

# CONFIGURATION (TIRE PRESSURE MONITORING SYSTEM)

< BASIC INSPECTION >

## CONFIGURATION (TIRE PRESSURE MONITORING SYSTEM)

### Work Procedure

INFOID:000000011763902

#### BEFORE REPLACEMENT

##### CAUTION:

- If BCM is replaced, perform “ADDITIONAL SERVICE WHEN REPLACING CONTROL UNIT” after the replacement. For details, refer to [BCS-64, "ADDITIONAL SERVICE WHEN REPLACING CONTROL UNIT \(BCM\) : Work Procedure"](#).
- Use “Manual Configuration” only when “TYPE ID” of BCM cannot be read.
- After configuration, perform the following:
  - Turn the ignition switch from OFF to ON and check that the low tire pressure warning lamp turns OFF after staying illuminated for approximately two seconds.
- If an error occurs during configuration, start over from the beginning.

#### 1. CHECKING BCM TYPE ID

1. Use FAST (service parts catalogue) to search BCM of the applicable vehicle and find “Type ID”.
2. Print out “Type ID”.

>> GO TO 2.

#### 2. CHECKING AIR PRESSURE MONITOR TYPE ID

##### CONSULT

1. Select “AIR PRESSURE MONITOR”.
2. Select “Before Replace ECU” of “Read/Write Configuration”.
3. Check if “Type ID” of air pressure monitor is displayed on the CONSULT screen.

Is “Type ID” displayed?

YES >> GO TO 3.

NO >> Replace BCM. Perform steps starting with “REPLACE BCM” described in [BCS-64, "ADDITIONAL SERVICE WHEN REPLACING CONTROL UNIT \(BCM\) : Work Procedure"](#).

#### 3. CHECKING AIR PRESSURE MONITOR TYPE ID AND BCM TYPE ID

##### CONSULT

Compare air pressure monitor “Type ID” displayed on the CONSULT screen with BCM “Type ID” searched for by using FAST (service parts catalogue), and check that these IDs match.

##### NOTE:

For the “Type ID” searched by using FAST (service parts catalog), use the last five digits of the “Type ID”.

>> GO TO 4.

#### 4. SAVING AIR PRESSURE MONITOR TYPE ID

##### CONSULT

Save “Type ID” of air pressure monitor on CONSULT.

>> Replace BCM. Perform steps starting with “REPLACE BCM” described in [BCS-64, "ADDITIONAL SERVICE WHEN REPLACING CONTROL UNIT \(BCM\) : Work Procedure"](#).

#### AFTER REPLACEMENT

##### CAUTION:

- Use “Manual Configuration” only when “Type ID” of CAN gateway cannot be read.
- If an error occurs during configuration, start over from the beginning.

#### 1. CHECKING AIR PRESSURE MONITOR TYPE ID

Check if “Type ID” of air pressure monitor is saved on CONSULT.

Is “TYPE ID” saved on CONSULT?

YES >> GO TO 2.

NO >> GO TO 3.

# CONFIGURATION (TIRE PRESSURE MONITORING SYSTEM)

< BASIC INSPECTION >

---

## 2. WRITING TYPE ID OF AIR PRESSURE MONITOR (AUTOMATIC WRITING)

---

### CONSULT

1. Select "After Replace ECU" of "Re/programming, Configuration" or that of "Read / Write Configuration".
2. Compare "Type ID" displayed on the CONSULT screen with BCM "Type ID" searched for by using FAST (service parts catalogue), and write matching "Type ID" on BCM.

**NOTE:**

For the "Type ID" searched by using FAST (service parts catalog), use the last five digits of the "Type ID".

>> GO TO 4.

---

## 3. WRITING TYPE ID OF AIR PRESSURE MONITOR (MANUAL WRITING)

---

### CONSULT

1. Select "Manual Configuration".
2. Select "Type ID" searched for by using FAST (service parts catalogue) and write the ID on BCM.

**NOTE:**

For the "Type ID" searched by using FAST (service parts catalog), use the last five digits of the "Type ID".

>> GO TO 4.

---

## 4. CHECKING AIR PRESSURE MONITOR TYPE ID AND BCM TYPE ID

---

Compare the air pressure monitor "Type ID" displayed on the CONSULT screen with BCM "Type" ID searched for by using FAST (service parts catalogue), and check that these IDs match.

**NOTE:**

For the "Type ID" searched by using FAST (service parts catalog), use the last five digits of the "Type ID".

>> GO TO 5.

---

## 5. PERFORM TIRE PRESSURE SENSOR ID REGISTRATION

---

Perform the tire pressure sensor ID registration. Refer to [WT-25. "Work Procedure"](#).

>> GO TO 6.

---

## 6. PERFORM SUPPLEMENTARY WORK

---

1. Adjust the tire pressures for all tires to the recommended value. Refer to [WT-74. "Tire Air Pressure"](#).
2. Perform the self-diagnosis of all systems.
3. Erase self-diagnosis results.

>> End of work.

# C1704, C1705, C1706, C1707 LOW TIRE PRESSURE

< DTC/CIRCUIT DIAGNOSIS >

## DTC/CIRCUIT DIAGNOSIS

### C1704, C1705, C1706, C1707 LOW TIRE PRESSURE

#### DTC Description

INFOID:0000000011373023

#### NOTE:

The Signal Tech II Tool [– (J-50190)] can be used to perform the following functions. Refer to the Signal Tech II User Guide for additional information.

- Activate and display TPMS sensor IDs
- Display tire pressure reported by the TPMS sensor
- Read TPMS DTCs
- Register TPMS sensor IDs

#### DTC DETECTION LOGIC

DTC No.	CONSULT screen terms (Trouble diagnosis content)	DTC detection condition	
C1704	LOW PRESSURE FL (Low tire pressure front left)	Diagnosis condition	When Ignition switch is ON.
		Signal (terminal)	Tire pressure sensor signal (–).
		Threshold	Tire pressure drops to 193.1 kPa (1.9 kg/cm <sup>2</sup> , 28 psi) or less
		Diagnosis delay time	–
C1705	LOW PRESSURE FR (Low tire pressure front right)	Diagnosis condition	When Ignition switch is ON.
		Signal (terminal)	Tire pressure sensor signal (–).
		Threshold	Tire pressure drops to 193.1 kPa (1.9 kg/cm <sup>2</sup> , 28 psi) or less
		Diagnosis delay time	–
C1706	LOW PRESSURE RR (Low tire pressure rear right)	Diagnosis condition	When Ignition switch is ON.
		Signal (terminal)	Tire pressure sensor signal (–).
		Threshold	Tire pressure drops to 193.1 kPa (1.9 kg/cm <sup>2</sup> , 28 psi) or less
		Diagnosis delay time	–
C1707	LOW PRESSURE RL (Low tire pressure rear left)	Diagnosis condition	When Ignition switch is ON.
		Signal (terminal)	Tire pressure sensor signal (–).
		Threshold	Tire pressure drops to 193.1 kPa (1.9 kg/cm <sup>2</sup> , 28 psi) or less
		Diagnosis delay time	–

#### POSSIBLE CAUSE

- Low tire pressure
- Tire pressure sensor

#### DTC CONFIRMATION PROCEDURE

##### 1. PERFORM SELF DIAGNOSTIC RESULT

#### CONSULT

1. Check tire pressure for all wheels and adjust to the specified value. Refer to [WT-74, "Tire Air Pressure"](#).
2. Drive at a speed of 40 km/h (25 MPH) or more for 3 minutes, and then drive the vehicle at any speed for 10 minutes.
3. Select "Self Diagnostic Result" mode in "AIR PRESSURE MONITOR" of "BCM".
4. Check DTC.

#### Is DTC C1704, C1705, C1706, or C1707 detected?

- YES >> Proceed to [WT-31, "Diagnosis Procedure"](#).  
NO >> Inspection End.

# C1704, C1705, C1706, C1707 LOW TIRE PRESSURE

< DTC/CIRCUIT DIAGNOSIS >

## Diagnosis Procedure

INFOID:000000011373024

### NOTE:

The Signal Tech II Tool [– (J-50190)] can be used to perform the following functions. Refer to the Signal Tech II User Guide for additional information.

- Activate and display TPMS sensor IDs
- Display tire pressure reported by the TPMS sensor
- Read TPMS DTCs
- Register TPMS sensor IDs

## 1. TIRE PRESSURE SENSOR ID REGISTRATION

Perform tire pressure sensor ID registration. Refer to [WT-25, "Work Procedure"](#).

Can the tire pressure sensor ID registration be completed?

YES >> GO TO 2.

NO >> Replace applicable tire pressure sensor. Refer to [WT-69, "Removal and Installation"](#).

## 2. CHECK TIRE PRESSURE

Check the air pressure of all wheels. Refer to [WT-74, "Tire Air Pressure"](#).

Is the inspection result normal?

YES >> Perform DTC CONFIRMATION PROCEDURE again. Refer to [WT-30, "DTC Description"](#).

NO >> GO TO 3.

## 3. CHECK TIRE PRESSURE SIGNAL

### With CONSULT

1. Adjust tire pressure for all wheels to the specified value. Refer to [WT-74, "Tire Air Pressure"](#).
2. Select "Data Monitor" mode in "AIR PRESSURE MONITOR" of "BCM".
3. Check that the air pressures match the specified value.

Monitor item	Displayed value
AIR PRESS FL	Approximately equal to value indicated on tire gauge for front LH tire
AIR PRESS FR	Approximately equal to value indicated on tire gauge for front RH tire
AIR PRESS RR	Approximately equal to value indicated on tire gauge for rear RH tire
AIR PRESS RL	Approximately equal to value indicated on tire gauge for rear LH tire

Is the inspection result normal?

YES >> Inspection End.

NO >> Repair or replace malfunctioning components.

# C1708, C1709, C1710, C1711 TIRE PRESSURE SENSOR

< DTC/CIRCUIT DIAGNOSIS >

## C1708, C1709, C1710, C1711 TIRE PRESSURE SENSOR

### DTC Description

INFOID:000000011373025

#### NOTE:

The Signal Tech II Tool [– (J-50190)] can be used to perform the following functions. Refer to the Signal Tech II User Guide for additional information.

- Activate and display TPMS sensor IDs
- Display tire pressure reported by the TPMS sensor
- Read TPMS DTCs
- Register TPMS sensor IDs

### DTC DETECTION LOGIC

DTC No.	CONSULT screen terms (Trouble diagnosis content)	DTC detection condition	
C1708	[NO – DATA] – FL (No data front left)	Diagnosis condition	When Ignition switch is ON.
		Signal (terminal)	<ul style="list-style-type: none"> <li>• Remote keyless entry receiver power circuit (terminal 1)</li> <li>• Remote keyless entry receiver signal circuit (terminal 2)</li> </ul>
		Threshold	Tire pressure data signal from the front LH wheel tire pressure sensor cannot be detected.
		Diagnosis delay time	–
C1709	[NO – DATA] – FR (No data front right)	Diagnosis condition	When Ignition switch is ON.
		Signal (terminal)	<ul style="list-style-type: none"> <li>• Remote keyless entry receiver power circuit (terminal 1)</li> <li>• Remote keyless entry receiver signal circuit (terminal 2)</li> </ul>
		Threshold	Tire pressure data signal from the front RH wheel tire pressure sensor cannot be detected.
		Diagnosis delay time	–
C1710	[NO – DATA] – RR (No data rear right left)	Diagnosis condition	When Ignition switch is ON.
		Signal (terminal)	<ul style="list-style-type: none"> <li>• Remote keyless entry receiver power circuit (terminal 1)</li> <li>• Remote keyless entry receiver signal circuit (terminal 2)</li> </ul>
		Threshold	Tire pressure data signal from the rear RH wheel tire pressure sensor cannot be detected.
		Diagnosis delay time	–
C1711	[NO – DATA] – RL (No data rear left)	Diagnosis condition	When Ignition switch is ON.
		Signal (terminal)	<ul style="list-style-type: none"> <li>• Remote keyless entry receiver power circuit (terminal 1)</li> <li>• Remote keyless entry receiver signal circuit (terminal 2)</li> </ul>
		Threshold	Tire pressure data signal from the rear LH wheel tire pressure sensor cannot be detected.
		Diagnosis delay time	–

#### POSSIBLE CAUSE

- Driving in area with radio interference.
- ID registration incomplete
- Tire pressure sensor
- Harness or connectors



# C1708, C1709, C1710, C1711 TIRE PRESSURE SENSOR

## < DTC/CIRCUIT DIAGNOSIS >

- Remote keyless entry receiver
- BCM

### DTC CONFIRMATION PROCEDURE

#### 1. PERFORM SELF DIAGNOSTIC RESULT

##### With CONSULT

1. Perform tire pressure sensor ID registration. Refer to [WT-25, "Work Procedure"](#).
2. Drive at a speed of 40 km/h (25 MPH) or more for 3 minutes, and then drive the vehicle at any speed for 10 minutes.

##### NOTE:

Avoid driving in areas with radio interference.

3. Select "Self Diagnostic Result" mode in "AIR PRESSURE MONITOR" of "BCM".
4. Check DTC.

#### Is DTC C1708, C1709, C1710, or C1711 detected?

- YES >> Proceed to [WT-33, "Diagnosis Procedure"](#).  
 NO >> Inspection End.

### Diagnosis Procedure

INFOID:000000011373026

##### NOTE:

The Signal Tech II Tool [- (J-50190)] can be used to perform the following functions. Refer to the Signal Tech II User Guide for additional information.

- Activate and display TPMS sensor IDs
- Display tire pressure reported by the TPMS sensor
- Read TPMS DTCs
- Register TPMS sensor IDs

Regarding Wiring Diagram information, refer to [WT-18, "Wiring Diagram"](#).

#### 1. CHECK TIRE PRESSURE SIGNAL

##### With CONSULT

1. Select "Data Monitor" mode in "AIR PRESSURE MONITOR" of "BCM".
2. Check that the air pressures match the specified value.

Monitor item	Displayed value
AIR PRESS FL	Approximately equal to specified value. Refer to <a href="#">WT-74, "Tire Air Pressure"</a> .
AIR PRESS FR	
AIR PRESS RR	
AIR PRESS RL	

#### Are all tire pressures displayed 0 kPa (psi)?

- YES >> GO TO 2.  
 NO >> Replace applicable tire pressure sensor. Refer to [WT-69, "Removal and Installation"](#).

#### 2. CHECK REMOTE KEYLESS ENTRY RECEIVER POWER CIRCUIT

Check voltage between remote keyless entry receiver connector M86 terminal 1 and ground.

Remote keyless entry receiver		Ground	Voltage (Approx.)
Connector	Terminal		
M86	1	—	Battery voltage

#### Is the inspection result normal?

- YES >> GO TO 3.  
 NO >> Repair or replace harness or connectors.

#### 3. CHECK REMOTE KEYLESS ENTRY RECEIVER SIGNAL

# C1708, C1709, C1710, C1711 TIRE PRESSURE SENSOR

## < DTC/CIRCUIT DIAGNOSIS >

1. Turn ignition switch ON.
2. Check signal between remote keyless entry receiver connector M86 terminal 2 and ground with an oscilloscope.

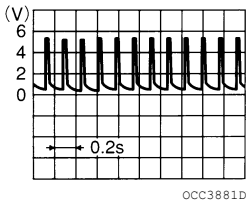
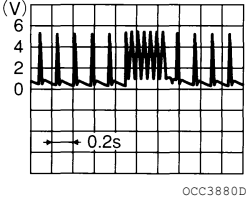
Remote keyless entry receiver		Condition	Voltage (Approx.)
Connector	Terminal		
M86	2	Standby state	
		When receiving the signal from the tire pressure sensor	

Is the inspection result normal?

- YES >> GO TO 6.  
 NO >> GO TO 4.

### 4. CHECK REMOTE KEYLESS ENTRY RECEIVER SIGNAL CIRCUIT

1. Turn ignition switch OFF.
2. Disconnect BCM connector M80 and remote keyless entry receiver connector.
3. Check continuity between BCM connector M80 terminal 119 and remote keyless entry receiver connector M86 terminal 2.

BCM		Remote keyless entry receiver		Continuity
Connector	Terminal	Connector	Terminal	
M80	119	M86	2	Yes

4. Check continuity between BCM connector M80 terminal 119 and ground.

BCM		Ground	Continuity
Connector	Terminal		
M80	119	—	No

Is the inspection result normal?

- YES >> GO TO 5.  
 NO >> Repair or replace harness or connectors.

### 5. CHECK REMOTE KEYLESS ENTRY RECEIVER GROUND CIRCUIT

Check continuity between remote keyless entry receiver connector M86 terminal 3 and ground.

Remote keyless entry receiver		Ground	Continuity
Connector	Terminal		
M86	3	—	Yes

Is the inspection result normal?

- YES >> Replace the remote keyless entry receiver. Refer to [WT-73, "Removal and Installation"](#).

# C1708, C1709, C1710, C1711 TIRE PRESSURE SENSOR

## < DTC/CIRCUIT DIAGNOSIS >

NO >> Repair or replace harness or connectors.

### 6. TIRE PRESSURE SENSOR ID REGISTRATION

Perform tire pressure sensor ID registration. Refer to [WT-25, "Work Procedure"](#).

Can the tire pressure sensor ID registration be completed?

YES >> GO TO 7.

NO >> Replace applicable tire pressure sensor. Refer to [WT-69, "Removal and Installation"](#).

### 7. RECHECK TIRE PRESSURE SIGNAL

#### With CONSULT

1. Drive at a speed of 40 km/h (25 MPH) or more for 3 minutes, and then drive the vehicle at any speed for 10 minutes.
2. Select "Data Monitor" mode in "AIR PRESSURE MONITOR" of "BCM".
3. Check that the air pressures match the specified value.

Monitor item	Displayed value
AIR PRESS FL	Approximately equal to specified value. Refer to <a href="#">WT-74, "Tire Air Pressure"</a> .
AIR PRESS FR	
AIR PRESS RR	
AIR PRESS RL	

Does Data Monitor display specified value without turning tire pressure warning lamp ON?

YES >> Inspection End.

NO >> Replace BCM. Refer to [BCS-82, "Removal and Installation"](#).

# C1716, C1717, C1718, C1719 TIRE PRESSURE SENSOR

< DTC/CIRCUIT DIAGNOSIS >

## C1716, C1717, C1718, C1719 TIRE PRESSURE SENSOR

### DTC Description

INFOID:000000011373029

#### NOTE:

The Signal Tech II Tool [– (J-50190)] can be used to perform the following functions. Refer to the Signal Tech II User Guide for additional information.

- Activate and display TPMS sensor IDs
- Display tire pressure reported by the TPMS sensor
- Read TPMS DTCs
- Register TPMS sensor IDs

### DTC DETECTION LOGIC

DTC No.	CONSULT screen terms (Trouble diagnosis content)	DTC detection condition	
		Diagnosis condition	Signal (terminal)
C1716	[PRESSUREDATA ERR] FL (Pressure data error front left)	Diagnosis condition	When Ignition switch is ON.
		Signal (terminal)	Tire pressure sensor signal (–).
		Threshold	Malfunction in the tire pressure data from the front LH wheel tire pressure sensor.
		Diagnosis delay time	–
C1717	[PRESSUREDATA ERR] FR (Pressure data error front right)	Diagnosis condition	When Ignition switch is ON.
		Signal (terminal)	Tire pressure sensor signal (–).
		Threshold	Malfunction in the tire pressure data from the front RH wheel tire pressure sensor.
		Diagnosis delay time	–
C1718	[PRESSUREDATA ERR] RR (Pressure data error rear right)	Diagnosis condition	When Ignition switch is ON.
		Signal (terminal)	Tire pressure sensor signal (–).
		Threshold	Malfunction in the tire pressure data from the rear RH wheel tire pressure sensor.
		Diagnosis delay time	–
C1719	[PRESSUREDATA ERR] RL (Pressure data error rear left)	Diagnosis condition	When Ignition switch is ON.
		Signal (terminal)	Tire pressure sensor signal (–).
		Threshold	Malfunction in the tire pressure data from the rear LH wheel tire pressure sensor.
		Diagnosis delay time	–

### POSSIBLE CAUSE

- Excessive tire pressure
- ID registration incomplete
- Tire pressure sensor
- BCM

### DTC CONFIRMATION PROCEDURE

#### 1. PERFORM SELF DIAGNOSTIC RESULT

##### With CONSULT

1. Check tire pressure for all wheels and adjust to the specified value. Refer to [WT-74. "Tire Air Pressure"](#).
2. Drive at a speed of 40 km/h (25 MPH) or more for 3 minutes, and then drive the vehicle at any speed for 10 minutes.
3. Select "Self Diagnostic Result" mode in "AIR PRESSURE MONITOR" of "BCM".
4. Check DTC.

Is DTC C1716, C1717, C1718, or C1719 detected?

- YES >> Proceed to [WT-37. "Diagnosis Procedure"](#).  
NO >> Inspection End.

# C1716, C1717, C1718, C1719 TIRE PRESSURE SENSOR

< DTC/CIRCUIT DIAGNOSIS >

## Diagnosis Procedure

INFOID:000000011373030

### NOTE:

The Signal Tech II Tool [– (J-50190)] can be used to perform the following functions. Refer to the Signal Tech II User Guide for additional information.

- Activate and display TPMS sensor IDs
- Display tire pressure reported by the TPMS sensor
- Read TPMS DTCs
- Register TPMS sensor IDs

## 1. TIRE PRESSURE SENSOR ID REGISTRATION

Perform tire pressure sensor ID registration. Refer to [WT-25, "Work Procedure"](#).

Can the tire pressure sensor ID registration be completed?

YES >> GO TO 2.

NO >> Replace applicable tire pressure sensor. Refer to [WT-69, "Removal and Installation"](#).

## 2. CHECK TIRE PRESSURE SIGNAL

### With CONSULT

1. Adjust tire pressure for all wheels to the specified value. Refer to [WT-74, "Tire Air Pressure"](#).
2. Select "Data Monitor" mode in "AIR PRESSURE MONITOR" of "BCM".
3. Check that the air pressures match the specified value.

Monitor item	Displayed value
AIR PRESS FL	Approximately equal to specified value. Refer to <a href="#">WT-74, "Tire Air Pressure"</a> .
AIR PRESS FR	
AIR PRESS RR	
AIR PRESS RL	

Is the inspection result normal?

YES >> Inspection End.

NO >> Replace BCM. Refer to [BCS-82, "Removal and Installation"](#).

# C1729 VEHICLE SPEED SIGNAL

< DTC/CIRCUIT DIAGNOSIS >

## C1729 VEHICLE SPEED SIGNAL

### DTC Description

INFOID:000000011373035

#### NOTE:

The Signal Tech II Tool [– (J-50190)] can be used to perform the following functions. Refer to the Signal Tech II User Guide for additional information.

- Activate and display TPMS sensor IDs
- Display tire pressure reported by the TPMS sensor
- Read TPMS DTCs
- Register TPMS sensor IDs

### DTC DETECTION LOGIC

DTC No.	CONSULT screen terms (Trouble diagnosis content)	DTC detection condition	
C1729	VHCL SPEED SIG ERR (Vehicle speed sensor error)	Diagnosis condition	When Ignition switch is ON.
		Signal (terminal)	Vehicle speed signal (–).
		Threshold	Vehicle speed signal is not detected.
		Diagnosis delay time	–

### POSSIBLE CAUSE

- CAN communication
- Combination meter
- BCM

### DTC CONFIRMATION PROCEDURE

#### 1. PERFORM SELF DIAGNOSTIC RESULT

##### With CONSULT

1. Drive at a speed of 40 km/h (25 MPH) or more for 3 minutes, and then drive the vehicle at any speed for 10 minutes.
2. Perform “Self Diagnostic Result” mode in “AIR PRESSURE MONITOR” of “BCM”.
3. Check DTC.

##### Is DTC C1729 detected?

- YES >> Proceed to [WT-38, "Diagnosis Procedure"](#).  
NO >> Inspection End.

### Diagnosis Procedure

INFOID:000000011373036

#### NOTE:

The Signal Tech II Tool [– (J-50190)] can be used to perform the following functions. Refer to the Signal Tech II User Guide for additional information.

- Activate and display TPMS sensor IDs
- Display tire pressure reported by the TPMS sensor
- Read TPMS DTCs
- Register TPMS sensor IDs

#### 1. PERFORM SELF DIAGNOSTIC RESULT FOR COMBINATION METER

##### With CONSULT

Perform “Self Diagnostic Result” of “METER M&A”. Refer to [MWI-20, "CONSULT Function \(METER/M&A\)"](#).

##### Are any DTCs detected?

- YES >> Refer to [MWI-29, "DTC Index"](#).  
NO >> GO TO 2.

#### 2. CHECK BCM INPUT/OUTPUT SIGNAL

Check BCM input/output signal values. Refer to [BCS-30, "Reference Value"](#).

## C1729 VEHICLE SPEED SIGNAL

< DTC/CIRCUIT DIAGNOSIS >

---

Is the inspection result normal?

YES >> Check pin terminal and connection of each harness connector for malfunctioning conditions.

NO >> Replace the BCM. Refer to [BCS-82. "Removal and Installation"](#).

A

B

C

D

WT

F

G

H

I

J

K

L

M

N

O

P

# C1730, C1731, C1732, C1733 FLAT TIRE

< DTC/CIRCUIT DIAGNOSIS >

## C1730, C1731, C1732, C1733 FLAT TIRE

### DTC Description

INFOID:000000011373037

#### NOTE:

The Signal Tech II Tool [– (J-50190)] can be used to perform the following functions. Refer to the Signal Tech II User Guide for additional information.

- Activate and display TPMS sensor IDs
- Display tire pressure reported by the TPMS sensor
- Read TPMS DTCs
- Register TPMS sensor IDs

### DTC DETECTION LOGIC

DTC No.	CONSULT screen terms (Trouble diagnosis content)	DTC detection condition	
C1730	FLAT TIRE FL (–)	Diagnosis condition	When Ignition switch is ON.
		Signal (terminal)	Tire pressure sensor signal (–).
		Threshold	Front left wheel pressure is 70 kPa (0.7 kg/cm <sup>2</sup> , 10 psi) or less.
		Diagnosis delay time	–
C1731	FLAT TIRE FR (–)	Diagnosis condition	When Ignition switch is ON.
		Signal (terminal)	Tire pressure sensor signal (–).
		Threshold	Front right wheel pressure is 70 kPa (0.7 kg/cm <sup>2</sup> , 10 psi) or less.
		Diagnosis delay time	–
C1732	FLAT TIRE RR (–)	Diagnosis condition	When Ignition switch is ON.
		Signal (terminal)	Tire pressure sensor signal (–).
		Threshold	Rear right wheel pressure is 70 kPa (0.7 kg/cm <sup>2</sup> , 10 psi) or less.
		Diagnosis delay time	–
C1733	FLAT TIRE RL (–)	Diagnosis condition	When Ignition switch is ON.
		Signal (terminal)	Tire pressure sensor signal (–).
		Threshold	Rear left wheel pressure is 70 kPa (0.7 kg/cm <sup>2</sup> , 10 psi) or less.
		Diagnosis delay time	–

### POSSIBLE CAUSE

- Low tire pressure
- Tire pressure sensor

### DTC CONFIRMATION PROCEDURE

#### 1. PERFORM SELF DIAGNOSTIC RESULT

##### Ⓜ With CONSULT

1. Check tire pressure for all wheels and adjust to the specified value. Refer to [WT-74, "Tire Air Pressure"](#).
2. Drive at a speed of 40 km/h (25 MPH) or more for 3 minutes, and then drive the vehicle at any speed for 10 minutes.
3. Select "Self Diagnostic Result" mode in "AIR PRESSURE MONITOR" of "BCM".
4. Check DTC.

Is DTC C1730, C1731, C1732, or C1733 detected?

- YES >> Proceed to [WT-41, "Diagnosis Procedure"](#).  
 NO >> Inspection End.



# C1730, C1731, C1732, C1733 FLAT TIRE

< DTC/CIRCUIT DIAGNOSIS >

## Diagnosis Procedure

INFOID:000000011373038

### NOTE:

The Signal Tech II Tool [– (J-50190)] can be used to perform the following functions. Refer to the Signal Tech II User Guide for additional information.

- Activate and display TPMS sensor IDs
- Display tire pressure reported by the TPMS sensor
- Read TPMS DTCs
- Register TPMS sensor IDs

## 1. TIRE PRESSURE SENSOR ID REGISTRATION

Perform tire pressure sensor ID registration. Refer to [WT-25, "Work Procedure"](#).

Can the tire pressure sensor ID registration be completed?

YES >> GO TO 2.

NO >> Replace applicable tire pressure sensor. Refer to [WT-69, "Removal and Installation"](#).

## 2. CHECK TIRE PRESSURE

Check the air pressure of all wheels. Refer to [WT-74, "Tire Air Pressure"](#).

Is the inspection result normal?

YES >> Perform DTC CONFIRMATION PROCEDURE again. Refer to [WT-40, "DTC Description"](#).

NO >> GO TO 3.

## 3. CHECK TIRE PRESSURE SIGNAL

### With CONSULT

1. Adjust tire pressure for all wheels to the specified value. Refer to [WT-74, "Tire Air Pressure"](#).
2. Select "Data Monitor" mode in "AIR PRESSURE MONITOR" of "BCM".
3. Check that the air pressures match the specified value.

Monitor item	Displayed value
AIR PRESS FL	Approximately equal to value indicated on tire gauge for front LH tire
AIR PRESS FR	Approximately equal to value indicated on tire gauge for front RH tire
AIR PRESS RR	Approximately equal to value indicated on tire gauge for rear RH tire
AIR PRESS RL	Approximately equal to value indicated on tire gauge for rear LH tire

Is the inspection result normal?

YES >> Inspection End.

NO >> Repair or replace malfunctioning components.

# C1734 CONTROL UNIT

< DTC/CIRCUIT DIAGNOSIS >

## C1734 CONTROL UNIT

### DTC Description

INFOID:000000011373039

#### NOTE:

The Signal Tech II Tool [– (J-50190)] can be used to perform the following functions. Refer to the Signal Tech II User Guide for additional information.

- Activate and display TPMS sensor IDs
- Display tire pressure reported by the TPMS sensor
- Read TPMS DTCs
- Register TPMS sensor IDs

### DTC DETECTION LOGIC

DTC No.	CONSULT screen terms (Trouble diagnosis content)	DTC detection condition	
C1734	CONTROL UNIT (Control unit)	Diagnosis condition	When Ignition switch is ON.
		Signal (terminal)	–
		Threshold	TPMS malfunction in BCM.
		Diagnosis delay time	–

### POSSIBLE CAUSE

BCM

### DTC CONFIRMATION PROCEDURE

#### 1. PERFORM SELF DIAGNOSTIC RESULT

##### With CONSULT

1. Turn ignition switch ON.
2. Select “Self Diagnostic Result” mode in “AIR PRESSURE MONITOR” of “BCM”.
3. Check DTC.

##### Is DTC C1734 detected?

- YES >> Proceed to [WT-42, "Diagnosis Procedure"](#).  
NO >> Inspection End.

### Diagnosis Procedure

INFOID:000000011373040

#### NOTE:

The Signal Tech II Tool [– (J-50190)] can be used to perform the following functions. Refer to the Signal Tech II User Guide for additional information.

- Activate and display TPMS sensor IDs
- Display tire pressure reported by the TPMS sensor
- Read TPMS DTCs
- Register TPMS sensor IDs

Regarding Wiring Diagram information, refer to [WT-18, "Wiring Diagram"](#).

#### 1. CHECK BCM HARNESS CONNECTORS

Check BCM harness connectors for damage or loose connections.

##### Is the inspection result normal?

- YES >> Repair or replace connectors.  
NO >> GO TO 2.

#### 2. CHECK BCM POWER SUPPLY AND GROUND

Check BCM power supply and ground. Refer to [BCS-75, "Diagnosis Procedure"](#).

##### Is the inspection result normal?

- YES >> GO TO 3.

# C1734 CONTROL UNIT

## < DTC/CIRCUIT DIAGNOSIS >

NO >> Repair or replace harness or connectors.

### 3. CHECK REMOTE KEYLESS ENTRY RECEIVER POWER CIRCUIT

Check voltage between remote keyless entry receiver connector M86 terminal 1 and ground.

Remote keyless entry receiver		Ground	Voltage (Approx.)
Connector	Terminal		
M86	1	—	Battery voltage

Is the inspection result normal?

YES >> GO TO 4.

NO >> Repair or replace harness or connectors.

### 4. CHECK REMOTE KEYLESS ENTRY RECEIVER SIGNAL CIRCUIT

1. Turn ignition switch OFF.
2. Disconnect BCM connector M80 and remote keyless entry receiver connector.
3. Check continuity between BCM connector M80 terminal 119 and remote keyless entry receiver connector M86 terminal 2.

BCM		Remote keyless entry receiver		Continuity
Connector	Terminal	Connector	Terminal	
M80	119	M86	2	Yes

4. Check continuity between BCM connector M80 terminal 119 and ground.

BCM		Ground	Continuity
Connector	Terminal		
M80	119	—	No

Is the inspection result normal?

YES >> GO TO 5.

NO >> Repair or replace harness or connectors.

### 5. CHECK REMOTE KEYLESS ENTRY RECEIVER GROUND CIRCUIT

Check continuity between remote keyless entry receiver connector M86 terminal 3 and ground.

Remote keyless entry receiver		Ground	Continuity
Connector	Terminal		
M86	3	—	Yes

Is the inspection result normal?

YES >> GO TO 6.

NO >> Repair or replace harness or connectors.

### 6. CHECK BCM INPUT/OUTPUT SIGNALS

Check BCM input/output signals. Refer to [BCS-30, "Reference Value"](#).

Is the inspection result normal?

YES >> Inspection End.

NO >> Replace BCM. Refer to [BCS-82, "Removal and Installation"](#).

# C1735 IGNITION SIGNAL

< DTC/CIRCUIT DIAGNOSIS >

## C1735 IGNITION SIGNAL

### DTC Logic

INFOID:000000011578375

#### NOTE:

The Signal Tech II Tool [– (J-50190)] can be used to perform the following functions. Refer to the Signal Tech II User Guide for additional information.

- Activate and display TPMS sensor IDs
- Display tire pressure reported by the TPMS sensor
- Read TPMS DTCs
- Register TPMS sensor IDs

### DTC DETECTION LOGIC

DTC No.	CONSULT screen terms (Trouble diagnosis content)	DTC detection condition	
		Diagnosis condition	When Ignition switch is ON.
C1735	IGNITION SIGNAL LINE - BCM/ TPMS (–)	Signal (terminal)	–
		Threshold	BCM has detected a mismatch between IGN ON signals.
		Diagnosis delay time	–

### POSSIBLE CAUSE

BCM

### DTC CONFIRMATION PROCEDURE

#### 1. PERFORM SELF DIAGNOSTIC RESULT

##### With CONSULT

1. Turn ignition switch ON.
2. Select “Self Diagnostic Result” mode in “AIR PRESSURE MONITOR” of “BCM”.
3. Check DTC.

##### Is DTC C1735 detected?

- YES >> Proceed to [WT-44, "Diagnosis Procedure"](#).
- NO >> Inspection End.

### Diagnosis Procedure

INFOID:000000011578376

#### NOTE:

The Signal Tech II Tool [– (J-50190)] can be used to perform the following functions. Refer to the Signal Tech II User Guide for additional information.

- Activate and display TPMS sensor IDs
- Display tire pressure reported by the TPMS sensor
- Read TPMS DTCs
- Register TPMS sensor IDs

#### 1. CHECK CAN IGNITION SIGNAL

##### With CONSULT

1. Select “INTELLIGENT KEY” of “BCM”.
2. Select “IGN RLY1-F/B” in “Data Monitor” mode.
3. Check that the function operates normally according to the following conditions:

Monitor item	Displayed value
IGN RLY1 F/B	On with ignition in ON position

##### Is the inspection result normal?

- YES >> GO TO 2.
- NO >> Check CAN system. Refer to [LAN-21, "Trouble Diagnosis Flow Chart"](#).

## C1735 IGNITION SIGNAL

< DTC/CIRCUIT DIAGNOSIS >

---

### 2.CHECK BCM POWER SUPPLY AND GROUND

---

Check BCM power supply and ground. Refer to [BCS-75, "Diagnosis Procedure"](#).

Is the inspection result normal?

YES >> GO TO 3.

NO >> Repair or replace harness or connectors.

### 3.DRIVE VEHICLE

---

Clear DTC and test drive vehicle to check for low tire pressure warning lamp.

Does the vehicle operate without any low tire pressure warning lamp?

YES >> Inspection End.

NO >> Replace BCM. Refer to [BCS-82, "Removal and Installation"](#).

A

B

C

D

WT

F

G

H

I

J

K

L

M

N

O

P

# C1761, C1762, C1763, C1764 TIRE PRESSURE SENSOR

< DTC/CIRCUIT DIAGNOSIS >

## C1761, C1762, C1763, C1764 TIRE PRESSURE SENSOR

### DTC Description

INFOID:000000011551870

#### NOTE:

The Signal Tech II Tool [– (J-50190)] can be used to perform the following functions. Refer to the Signal Tech II User Guide for additional information.

- Activate and display TPMS sensor IDs
- Display tire pressure reported by the TPMS sensor
- Read TPMS DTCs
- Register TPMS sensor IDs

### DTC DETECTION LOGIC

DTC No.	CONSULT screen terms (Trouble diagnosis content)	DTC detection condition	
		Diagnosis condition	Signal (terminal)
C1761	TEMPERATURE DATA FL (Temperature data front left)	Diagnosis condition	When Ignition switch is ON.
		Signal (terminal)	Temperature data signal (–).
		Threshold	Malfunction in the tire temperature data from the front LH wheel tire pressure sensor.
		Diagnosis delay time	–
C1762	TEMPERATURE DATA FR (Temperature data front right)	Diagnosis condition	When Ignition switch is ON.
		Signal (terminal)	Temperature data signal (–).
		Threshold	Malfunction in the tire temperature data from the front RH wheel tire pressure sensor.
		Diagnosis delay time	–
C1763	TEMPERATURE DATA RR (Temperature data rear right)	Diagnosis condition	When Ignition switch is ON.
		Signal (terminal)	Temperature data signal (–).
		Threshold	Malfunction in the tire temperature data from the rear RH wheel tire pressure sensor.
		Diagnosis delay time	–
C1764	TEMPERATURE DATA RL (Temperature data rear left)	Diagnosis condition	When Ignition switch is ON.
		Signal (terminal)	Temperature data signal (–).
		Threshold	Malfunction in the tire temperature data from the rear LH wheel tire pressure sensor.
		Diagnosis delay time	–

### POSSIBLE CAUSE

- Tire pressure sensor
- BCM

### DTC CONFIRMATION PROCEDURE

#### 1. PERFORM SELF DIAGNOSTIC RESULT

##### With CONSULT

1. Turn ignition switch ON.
2. Select “Self Diagnostic Result” mode in “AIR PRESSURE MONITOR” of “BCM”.
3. Check DTC.

Is DTC “C1761”, “C1762”, “C1763”, or “C1764” detected?

- YES >> Proceed to [WT-46, "Diagnosis Procedure"](#).
- NO-1 >> Prior to repair: Refer to [GI-42, "Intermittent Incident"](#).
- NO-2 >> Confirmation after repair: Inspection End.

### Diagnosis Procedure

INFOID:000000011551871

#### NOTE:

# C1761, C1762, C1763, C1764 TIRE PRESSURE SENSOR

## < DTC/CIRCUIT DIAGNOSIS >

The Signal Tech II Tool [– (J-50190)] can be used to perform the following functions. Refer to the Signal Tech II User Guide for additional information.

- Activate and display TPMS sensor IDs
- Display tire pressure reported by the TPMS sensor
- Read TPMS DTCs
- Register TPMS sensor IDs

### 1. PERFORM BCM SELF-DIAGNOSIS

1. Replace applicable tire pressure sensor. Refer to [WT-69, "Removal and Installation"](#).
2. Select "Self Diagnostic Result" mode in "AIR PRESSURE MONITOR" of "BCM".
3. Check DTC.

Is DTC "C1761", "C1762", "C1763", or "C1764" detected?

- YES >> Replace BCM. Refer to [BCS-82, "Removal and Installation"](#).  
NO >> Inspection End.

A  
B  
C  
D  
E  
F  
G  
H  
I  
J  
K  
L  
M  
N  
O  
P

WT

# C1769 CONFIGURATION SETTING

< DTC/CIRCUIT DIAGNOSIS >

## C1769 CONFIGURATION SETTING

### DTC Description

INFOID:000000011551872

#### NOTE:

The Signal Tech II Tool [– (J-50190)] can be used to perform the following functions. Refer to the Signal Tech II User Guide for additional information.

- Activate and display TPMS sensor IDs
- Display tire pressure reported by the TPMS sensor
- Read TPMS DTCs
- Register TPMS sensor IDs

### DTC DETECTION LOGIC

DTC No.	CONSULT screen terms (Trouble diagnosis content)	DTC detection condition	
C1769	CONFIG SETTING (Configuration setting)	Diagnosis condition	When Ignition switch is ON.
		Signal (terminal)	–
		Threshold	<ul style="list-style-type: none"><li>• Tire pressure monitoring system configuration has not been performed.</li><li>• Receiver ID registration cannot be performed.</li></ul>
		Diagnosis delay time	–

### POSSIBLE CAUSE

- Configuration is not completed.
- The ID registration is not completed.

### DTC CONFIRMATION PROCEDURE

#### 1. PERFORM SELF DIAGNOSTIC RESULT

##### With CONSULT

1. Turn ignition switch ON.
2. Select “Self Diagnostic Result” mode in “AIR PRESSURE MONITOR” of “BCM”.
3. Check DTC.

##### Is DTC “C1769” detected?

- YES >> Proceed to [WT-48, "Diagnosis Procedure"](#).  
NO-1 >> Prior to repair: Refer to [GI-42, "Intermittent Incident"](#).  
NO-2 >> Confirmation after repair: Inspection End.

### Diagnosis Procedure

INFOID:000000011551873

#### NOTE:

The Signal Tech II Tool [– (J-50190)] can be used to perform the following functions. Refer to the Signal Tech II User Guide for additional information.

- Activate and display TPMS sensor IDs
- Display tire pressure reported by the TPMS sensor
- Read TPMS DTCs
- Register TPMS sensor IDs

#### 1. TIRE PRESSURE MONITORING SYSTEM CONFIGURATION

Perform configuration. Refer to [WT-28, "Work Procedure"](#).

>> GO TO 2.

#### 2. TIRE PRESSURE SENSOR ID REGISTRATION

Perform tire pressure sensor ID registration. Refer to [WT-25, "Work Procedure"](#).

Does low tire pressure warning lamp turn OFF?



# C1769 CONFIGURATION SETTING

## < DTC/CIRCUIT DIAGNOSIS >

---

YES >> Inspection End.

NO >> Perform configuration tire pressure monitoring system again. Refer to [WT-28, "Work Procedure"](#).

A

B

C

D

WT

F

G

H

I

J

K

L

M

N

O

P

# C1770, C1771, C1772, C1773 G SENSOR

< DTC/CIRCUIT DIAGNOSIS >

## C1770, C1771, C1772, C1773 G SENSOR

### DTC Description

INFOID:000000011551874

#### NOTE:

The Signal Tech II Tool [– (J-50190)] can be used to perform the following functions. Refer to the Signal Tech II User Guide for additional information.

- Activate and display TPMS sensor IDs
- Display tire pressure reported by the TPMS sensor
- Read TPMS DTCs
- Register TPMS sensor IDs

### DTC DETECTION LOGIC

DTC No.	CONSULT screen terms (Trouble diagnosis content)	DTC detection condition	
		Diagnosis condition	Signal (terminal)
C1770	G SENSOR FL (G sensor front left)	Diagnosis condition	When Ignition switch is ON.
		Signal (terminal)	–
		Threshold	Malfunction in the G sensor data from front LH wheel sensor.
		Diagnosis delay time	–
C1771	G SENSOR FR (G sensor front right)	Diagnosis condition	When Ignition switch is ON.
		Signal (terminal)	–
		Threshold	Malfunction in the G sensor data from front RH wheel sensor.
		Diagnosis delay time	–
C1772	G SENSOR RL (G sensor rear right)	Diagnosis condition	When Ignition switch is ON.
		Signal (terminal)	–
		Threshold	Malfunction in the G sensor data from rear RH wheel sensor.
		Diagnosis delay time	–
C1773	G SENSOR RR (G sensor rear left)	Diagnosis condition	When Ignition switch is ON.
		Signal (terminal)	–
		Threshold	Malfunction in the G sensor data from rear LH wheel sensor.
		Diagnosis delay time	–

#### NOTE:

The actual malfunction part may differ from the malfunction part which DTC shows if ID registration is not performed after performing tire rotation or tire/road wheel replacement.

#### POSSIBLE CAUSE

Tire pressure sensor

#### DTC CONFIRMATION PROCEDURE

##### 1. PERFORM SELF DIAGNOSTIC RESULT

#### With CONSULT

1. Turn ignition switch ON.
2. Select “Self Diagnostic Result” mode in “AIR PRESSURE MONITOR” of “BCM”.
3. Check DTC.

Is DTC “C1770”, “C1771”, “C1772”, or “C1773” detected?

- YES >> Proceed to [WT-51, "Diagnosis Procedure"](#).  
NO-1 >> Prior to repair: Refer to [GI-42, "Intermittent Incident"](#).  
NO-2 >> Confirmation after repair: Inspection End.

# C1770, C1771, C1772, C1773 G SENSOR

< DTC/CIRCUIT DIAGNOSIS >

## Diagnosis Procedure

INFOID:0000000011551875

### NOTE:

The Signal Tech II Tool [– (J-50190)] can be used to perform the following functions. Refer to the Signal Tech II User Guide for additional information.

- Activate and display TPMS sensor IDs
- Display tire pressure reported by the TPMS sensor
- Read TPMS DTCs
- Register TPMS sensor IDs

## 1. PERFORM BCM SELF-DIAGNOSIS

1. Replace tire pressure sensor. Refer to [WT-69, "Removal and Installation"](#).
2. Select "Self Diagnostic Result" mode in "AIR PRESSURE MONITOR" of "BCM".
3. Check DTC.

Is DTC "C1770", "C1771", "C1772", or "C1773" detected?

- YES >> Replace the BCM. Refer to [BCS-82, "Removal and Installation"](#).  
NO >> Inspection End.

A  
B  
C  
D  
E  
F  
G  
H  
I  
J  
K  
L  
M  
N  
O  
P

WT

# U1000 CAN COMM CIRCUIT

< DTC/CIRCUIT DIAGNOSIS >

## U1000 CAN COMM CIRCUIT

### Description

INFOID:000000011551876

CAN (Controller Area Network) is a serial communication line for real time application. It is an on-vehicle multiplex communication line with high data communication speed and excellent error detection ability. Many electronic control units are equipped onto a vehicle, and each control unit shares information and links with other control units during operation (not independent). In CAN communication, control units are connected with 2 communication lines (CAN-H line, CAN-L line) allowing a high rate of information transmission with less wiring. Each control unit communicates data but selectively reads required data only.

### DTC DETECTION LOGIC

DTC No.	CONSULT screen terms (Trouble diagnosis content)	DTC detection condition	
U1000	CAN COMM CIRCUIT (CAN communication circuit)	Diagnosis condition	When Ignition switch is ON.
		Signal (terminal)	CAN communication signal (terminal 59 and 60)
		Threshold	BCM is not sending or receiving CAN communication.
		Diagnosis delay time	2 seconds or more

### POSSIBLE CAUSE

- CAN communication malfunction
- Malfunction of BCM

### DTC CONFIRMATION PROCEDURE

#### 1. PERFORM DTC CONFIRMATION

##### Ⓟ With CONSULT

1. Drive for several minutes at a speed of 40 km/h (25 MPH) or more.
2. Stop the vehicle.
3. Select "Self Diagnostic Result" mode in "AIR PRESSURE MONITOR" of "BCM".
4. Check DTC.

##### Is DTC "U1000" detected?

- YES >> Proceed to [WT-52, "Diagnosis Procedure"](#).
- NO-1 >> Prior to repair: Refer to [GI-42, "Intermittent Incident"](#).
- NO-2 >> Confirmation after repair: Inspection End.

### Diagnosis Procedure

INFOID:000000011551878

#### 1. PERFORM SELF DIAGNOSTIC RESULT

##### Ⓟ With CONSULT

1. Turn the ignition switch ON and wait for 2 seconds or more.
2. Select "Self Diagnostic Result" mode in "AIR PRESSURE MONITOR" of "BCM".
3. Check DTC.

##### Is DTC "U1000" detected?

- YES >> Refer to [LAN-35, "CAN COMMUNICATION SYSTEM : CAN System Specification Chart"](#).
- NO >> Inspection End.

# U1010 CONTROL UNIT (CAN)

< DTC/CIRCUIT DIAGNOSIS >

## U1010 CONTROL UNIT (CAN)

### Description

INFOID:000000011551879

CAN (Controller Area Network) is a serial communication line for real time application. It is an on-vehicle multiplex communication line with high data communication speed and excellent error detection ability. Many electronic control units are equipped onto a vehicle, and each control unit shares information and links with other control units during operation (not independent). In CAN communication, control units are connected with 2 communication lines (CAN-H line, CAN-L line) allowing a high rate of information transmission with less wiring. Each control unit communicates data but selectively reads required data only.

### DTC DETECTION LOGIC

DTC No.	CONSULT screen terms (Trouble diagnosis content)	DTC detection condition	
U1010	CONTROL UNIT (CAN) [Control unit (CAN)]	Diagnosis condition	When Ignition switch is ON.
		Signal (terminal)	CAN communication signal (terminal 59 and 60)
		Threshold	Error detected during the initial diagnosis of CAN controller of BCM.
		Diagnosis delay time	–

### POSSIBLE CAUSE

BCM

### DTC CONFIRMATION PROCEDURE

#### 1. PERFORM DTC CONFIRMATION

##### With CONSULT

1. Drive for several minutes at a speed of 40 km/h (25 MPH) or more.
2. Stop the vehicle.
3. Perform "Self Diagnostic Result" mode in "AIR PRESSURE MONITOR" of "BCM".
4. Check DTC.

##### Is DTC "U1010" detected?

- YES >> Proceed to [WT-53. "Diagnosis Procedure"](#).  
NO-1 >> Prior to repair: Refer to [GI-42. "Intermittent Incident"](#).  
NO-2 >> Confirmation after repair: Inspection End.

### Diagnosis Procedure

INFOID:000000011551881

#### 1. CHECK BCM

Check BCM harness connector for disconnection or deformation.

##### Is the inspection result normal?

- YES >> Replace BCM. Refer to [BCS-82. "Removal and Installation"](#).  
NO >> Repair or replace malfunctioning components.

# LOW TIRE PRESSURE WARNING LAMP

< DTC/CIRCUIT DIAGNOSIS >

---

## LOW TIRE PRESSURE WARNING LAMP

### Component Function Check

INFOID:000000011551882

#### 1. CHECK THE ILLUMINATION OF THE LOW TIRE PRESSURE WARNING LAMP

Check that the low tire pressure warning lamp is turned OFF after illuminating for approximately 1 second, when the ignition switch is turned ON.

Is the inspection result normal?

YES >> Inspection End.

NO >> Perform trouble diagnosis. Refer to [WT-54, "Diagnosis Procedure"](#).

### Diagnosis Procedure

INFOID:000000011551883

#### 1. BCM POWER SUPPLY AND GROUND CIRCUIT

Check BCM power supply and ground circuit. Refer to [BCS-75, "Diagnosis Procedure"](#).

Is the inspection result normal?

YES >> GO TO 2.

NO >> Repair or replace malfunctioning components.

#### 2. PERFORM SELF-DIAGNOSIS

Ⓜ With CONSULT

Perform "Self Diagnostic Result" of "AIR PRESSURE MONITOR" in "BCM".

Is any DTC detected?

YES >> Check the DTC. Refer to [BCS-52, "DTC Index"](#).

NO >> GO TO 3.

#### 3. CHECK LOW TIRE PRESSURE WARNING LAMP SIGNAL

Ⓜ With CONSULT

1. Turn the ignition switch ON.

**CAUTION:**

**Never start the engine.**

2. Select "Data Monitor" in "AIR PRESSURE MONITOR" of "BCM".

3. Select "WARNING LAMP" in "Data Monitor", and check that the low tire pressure warning lamp is turned OFF after illuminating for approximately 1 second, when the ignition switch is turned ON.

Is the inspection result normal?

YES >> Check the combination meter. Refer to [MWI-59, "COMBINATION METER : Diagnosis Procedure"](#).

NO >> Replace the BCM. Refer to [BCS-82, "Removal and Installation"](#).



















# SYMPTOM DIAGNOSIS

## TPMS

### Symptom Table

INFOID:000000011552617

### LOW TIRE PRESSURE WARNING LAMP SYMPTOM CHART



Diagnosis items	Symptom (Ignition switch ON)	Low tire pressure warning lamp	Cause	Action
Low tire pressure warning lamp	The low tire pressure warning lamp illuminates for 1 second, then turns OFF.	  ON 1 sec > stays OFF <small>SEIA0592E</small>	Wake-up operation for all tire pressure sensors at wheels is completed.	No system malfunctions
	The low tire pressure warning lamp repeats blinking ON for 2 seconds and OFF for 0.2 seconds. 1 minute later, low tire pressure warning lamp turns ON.	 Blinks:  ON 2 sec > OFF 0.2 sec  Maintains ON 1 minute later <small>JSEIA0805GB</small>	Wake-up operation for all tire pressure sensors at wheels is not completed.	Perform the ID registration for all tire pressure sensors at wheels. Refer to <a href="#">WT-25, "Work Procedure"</a> .
	The low tire pressure warning lamp blinks once. 1 minute later, low tire pressure warning lamp turns ON.	 Blinks 1 time ON 0.3 sec > OFF 1.0 sec  Maintains ON 1 minute later <small>JSEIA0806GB</small>	The front left tire pressure sensor is not activated.	Perform the ID registration for the tire pressure sensor at front left wheel. Refer to <a href="#">WT-25, "Work Procedure"</a> .
	The low tire pressure warning lamp repeats blinking twice. 1 minute later, low tire pressure warning lamp turns ON.	  Blinks 2 times ON 0.3 sec > OFF 0.3 sec  Maintains ON 1 minute later <small>JSEIA0807GB</small>	The front right tire pressure sensor is not activated.	Perform the ID registration for the tire pressure sensor at front right wheel. Refer to <a href="#">WT-25, "Work Procedure"</a> .
	The low tire pressure warning lamp repeats blinking for 3 times. 1 minute later, low tire pressure warning lamp turns ON.	   Blinks 3 times ON 0.3 sec > OFF 0.3 sec  Maintains ON 1 minute later <small>JSEIA0808GB</small>	The rear right tire pressure sensor is not activated.	Perform the ID registration for the tire pressure sensor at rear right wheel. Refer to <a href="#">WT-25, "Work Procedure"</a> .
	The low tire pressure warning lamp repeats blinking for 4 times. 1 minute later, low tire pressure warning lamp turns ON.	    Blinks 4 times ON 0.3 sec > OFF 0.3 sec  Maintains ON 1 minute later <small>JSEIA0809GB</small>	The rear left tire pressure sensor is not activated.	Perform the ID registration for the tire pressure sensor at rear left wheel. Refer to <a href="#">WT-25, "Work Procedure"</a> .

A  
B  
C  
D  
E  
F  
G  
H  
I  
J  
K  
L  
M  
N  
O  
P

WT

# TPMS

## < SYMPTOM DIAGNOSIS >

Diagnosis items	Symptom (Ignition switch ON)	Low tire pressure warning lamp	Cause	Action
Low tire pressure warning lamp	The low tire pressure warning lamp turns ON and stays illuminated.	 Comes ON and stays ON <small>SEIA0598E</small>	Low tire pressure	Check the tire pressure for all wheels and adjust to the specified value. Refer to <a href="#">WT-25, "Work Procedure"</a> .
Low tire pressure warning lamp	The low tire pressure warning lamp repeats blinking at 0.5-second intervals for 1 minute, and then stays illuminated.	 Blinks 1 min ON 0.5 sec > OFF 0.5 sec and stays ON <small>SEIA0788E</small>	The combination meter fuse is open or removed (or pulled out).	Check and install the combination meter fuse. If necessary, replace the fuse.
			The BCM harness connector is removed.	Check the connection conditions of the BCM harness connector, and repair if necessary.
			Tire Pressure Monitoring System (TPMS) malfunction.	<ul style="list-style-type: none"> <li>Perform CONSULT self-diagnosis. Refer to <a href="#">WT-13, "AIR PRESSURE MONITOR : CONSULT Function (BCM-AIR PRESSURE MONITOR)"</a>.</li> <li>If necessary, perform tire pressure sensor ID registration. Refer to <a href="#">WT-25, "Work Procedure"</a>.</li> </ul>
Low tire pressure warning lamp	The low tire pressure warning lamp blinks once.	 Blinks 4 times ON 0.3 sec > OFF 0.3 sec and stays ON <small>JSEIA0734GB</small>	Wake-up operation for all tire pressure sensors at wheels is not completed.	Perform the ID registration for all tire pressure sensors at wheels. Refer to <a href="#">WT-25, "Work Procedure"</a> .
Hazard warning lamp	The hazard warning lamp does not blink twice when the tire pressure sensor is activated. Or the buzzer does not sound.	—	The tire pressure sensor activation tool does not activate.	Replace the battery in the tire pressure sensor activation tool.
			The ignition switch is OFF when the tire pressure sensor wake-up operation is performed.	Turn the ignition switch ON when performing the tire pressure sensor wake-up operation.
			The tire pressure sensor activation tool is not used in the correct position.	Operate the tire pressure sensor activation tool in the correct position when performing the wake-up operation.
			The tire pressure sensor is already waked up.	No procedure.

**NOTE:**

If tire pressure sensor wake-up operation is not completed for two or more tire pressure sensors, the applicable low tire pressure warning lamp blinking patterns are displayed continuously.  
(Example: Blinks once/OFF/blinks 3 times = Wake-up operation is not completed at the front left wheel and rear right wheel tire pressure sensors.)



# LOW TIRE PRESSURE WARNING LAMP DOES NOT TURN ON

< SYMPTOM DIAGNOSIS >

## LOW TIRE PRESSURE WARNING LAMP DOES NOT TURN ON

Low Tire Pressure Warning Lamp Does Not Come On When Ignition Switch Is Turned On

INFOID:000000011373044

### NOTE:

The Signal Tech II Tool [– (J-50190)] can be used to perform the following functions. Refer to the Signal Tech II User Guide for additional information.

- Activate and display TPMS sensor IDs
- Display tire pressure reported by the TPMS sensor
- Read TPMS DTCs
- Register TPMS sensor IDs

### 1. PERFORM SELF DIAGNOSTIC RESULT

#### Ⓜ With CONSULT

1. Turn ignition switch ON.
2. Select “Self Diagnostic Result” mode in “AIR PRESSURE MONITOR” of “BCM”.
3. Check DTC.

Is DTC U1000 detected?

- YES >> Refer to [LAN-21, "Trouble Diagnosis Flow Chart"](#).  
NO >> GO TO 2.

### 2. CHECK COMBINATION METER

Check combination meter operation. Refer to [MWI-20, "CONSULT Function \(METER/M&A\)"](#).

Is the inspection result normal?

- YES >> GO TO 3.  
NO >> Replace combination meter. Refer to [MWI-78, "Removal and Installation"](#).

### 3. CHECK LOW TIRE PRESSURE WARNING LAMP

Disconnect BCM harness connector.

Does the low tire pressure warning lamp activate?

- YES >> Replace BCM. Refer to [BCS-82, "Removal and Installation"](#).  
NO >> Check combination meter operation.

# LOW TIRE PRESSURE WARNING LAMP STAYS ON

< SYMPTOM DIAGNOSIS >

---

## LOW TIRE PRESSURE WARNING LAMP STAYS ON

Low Tire Pressure Warning Lamp Stays On When Ignition Switch Is Turned On

INFOID:000000011373045

### 1. CHECK BCM CONNECTORS

---

1. Turn ignition switch OFF.
2. Disconnect BCM connectors.
3. Check terminals for damage or loose connections.

Is the inspection result normal?

- YES >> GO TO 2.  
NO >> Repair or replace damaged connectors.

### 2. BCM POWER SUPPLY AND GROUND CIRCUITS

---

Check BCM power supply and ground circuits. Refer to [BCS-75. "Diagnosis Procedure"](#).

Is the inspection result normal?

- YES >> Replace BCM. Refer to [BCS-82. "Removal and Installation"](#).  
NO >> Repair BCM circuits.

# LOW TIRE PRESSURE WARNING LAMP BLINKS

< SYMPTOM DIAGNOSIS >

## LOW TIRE PRESSURE WARNING LAMP BLINKS

### Description

INFOID:000000011551884

When the ignition switch is turned ON, the low tire pressure warning lamp blinks. And then 1 minute later, low tire pressure warning lamp turns ON.

**NOTE:**

The position of an inactive tire pressure sensor can be identified by checking the blinking timing of the low tire pressure warning lamp.

Low tire pressure warning lamp blinking timing		Activation tire position
ON OFF		a : 0.3 sec. b : 1.0 sec. Front LH
ON OFF		a : 0.3 sec. b : 1.0 sec. Front RH
ON OFF		a : 0.3 sec. b : 1.0 sec. Rear RH
ON OFF		a : 0.3 sec. b : 1.0 sec. Rear LH
ON OFF		a : 2 sec. b : 0.2 sec. All tires

JPEIC0089GB

### Diagnosis Procedure

INFOID:000000011551885

#### 1. TIRE PRESSURE SENSOR ID REGISTRATION

Perform tire pressure sensor ID registration. Refer to [WT-25. "Work Procedure"](#).

Is tire pressure sensor ID registration completed?

YES >> Inspection End.

NO >> Perform the self-diagnosis for "AIR PRESSURE MONITOR". Refer to [BCS-52. "DTC Index"](#).

# EASY FILL TIRE ALERT DOES NOT ACTIVATE

< SYMPTOM DIAGNOSIS >

---

## EASY FILL TIRE ALERT DOES NOT ACTIVATE

### Description

INFOID:000000011373046

The Easy Fill tire alert does not function while inflating a tire when the select lever position is in P-range with the ignition switch ON.

#### NOTE:

- After starting to inflate the tire, it takes a few seconds for the easy fill tire alert to function.
- If there is no response for approximately 15 seconds or more after inflating the tires, cancel the use of the Easy Fill tire alert function or move the vehicle approximately 1 m (3.2 ft.) backward or forward to try again. The air filler pressure may be weak or out of service area.
- For Easy Fill tire alert, Refer to [WT-11, "Easy Fill Tire Alert Function"](#).

### Diagnosis Procedure

INFOID:000000011373047

#### 1. LOCATION CHANGE

Move the vehicle to another area and repeat the procedure of the Easy fill tire alert function. Refer to [WT-11, "Easy Fill Tire Alert Function"](#).

##### Is the function normal?

- YES >> Inspection End.  
NO >> GO TO 2.

#### 2. PERFORM SELF DIAGNOSTIC RESULT

##### Ⓟ With CONSULT

1. Turn ignition switch ON.
2. Select "Self Diagnostic Result" mode in "AIR PRESSURE MONITOR" of "BCM".
3. Check DTC.

##### Are any DTCs detected?

- YES >> Refer to [BCS-52, "DTC Index"](#).  
NO >> GO TO 3.

#### 3. CHECK HAZARD WARNING LAMP OPERATION

Check hazard warning lamp operation with hazard switch.

##### Do the hazard warning lamps operate?

- YES >> GO TO 4.  
NO >> Refer to [DLK-209, "Diagnosis Procedure"](#).

#### 4. PERFORM SELF DIAGNOSTIC RESULT FOR TCM

##### Ⓟ With CONSULT

1. Turn ignition switch ON.
2. Select "Self Diagnostic Result" mode of "TRANSMISSION".
3. Check DTC.

##### Are any DTCs detected?

- YES >> Refer to [TM-42, "CONSULT Function"](#).  
NO >> GO TO 5.

#### 5. CHECK HORN OPERATION

Check horn operation. Refer to [SEC-139, "Diagnosis Procedure"](#).

##### Is the inspection result normal?

- YES >> GO TO 6.  
NO >> Repair or replace malfunctioning components.

#### 6. PERFORM SELF DIAGNOSTIC RESULT

##### Ⓟ With CONSULT

1. Drive at a speed of 40 km/h (25 MPH) or more for 3 minutes, and then drive the vehicle at any speed for 10 minutes.
2. Select "Self Diagnostic Result" mode in "AIR PRESSURE MONITOR" of "BCM".
3. Check DTC.

# EASY FILL TIRE ALERT DOES NOT ACTIVATE

< SYMPTOM DIAGNOSIS >

---

Are any DTCs detected?

YES >> Refer to [BCS-52, "DTC Index"](#).

NO >> Replace BCM. Refer to [BCS-82, "Removal and Installation"](#).

A

B

C

D

WT

F

G

H

I

J

K

L

M

N

O

P

# ID REGISTRATION CANNOT BE COMPLETED

< SYMPTOM DIAGNOSIS >

---

## ID REGISTRATION CANNOT BE COMPLETED

### Description

INFOID:000000011551886

The ID of the tire pressure sensor installed in each wheel cannot be registered in the tire pressure monitoring system.

Inspect the tire pressure sensor or the tire pressure monitoring system circuit.

### Diagnosis Procedure

INFOID:000000011551887

#### 1. CHECK TIRE PRESSURE SENSOR ACTIVATION TOOL

---

Check tire pressure sensor activation tool.

Is the inspection result normal?

YES >> GO TO 2.

NO >> Replace the battery of tire pressure sensor activation tool or repair/replace the tire pressure sensor activation tool.

#### 2. TIRE PRESSURE SENSOR ID REGISTRATION

---

Perform tire pressure sensor ID registration. Refer to [WT-25. "Work Procedure"](#).

##### **CAUTION:**

To perform ID registration, observe the following points:

- Never register ID in a place where radio waves are interfered (e.g. radio tower).
- Never register ID in a place close to vehicles including TPMS.

Is tire pressure sensor ID registration completed?

YES >> Inspection End.

NO >> GO TO 3.

#### 3. CHECK TIRE PRESSURE SIGNAL

---

Change the work location and perform ID registration again.

##### **NOTE:**

Depending on the tire pressure sensor position\*, a blind spot exists, and the tire pressure receiver gets poor reception. If an ID registration is performed under this condition, the registration may not be completed. In such case, follow the instructions below to improve the radio wave receiving environment.

- Rotate tire by 90°, 180°, or 270°. (This Step is to change tire pressure sensor position.)
- Open the door close to the tire of which ID registration is ongoing.

\*: Radio wave reception condition depends on vehicle architecture (e.g. body harness layout, tire wheel design) or environment.

When ID registration is performed, which wheels do not react?

All wheels react and ID registration is possible.>>Inspection End.

Only certain wheel(s) do not react.>>Replace applicable tire pressure sensor. Refer to [WT-69. "Removal and Installation"](#).

All wheels do not react.>>Check the tire pressure receiver (remote keyless entry receiver). Refer to [DLK-196. "Diagnosis Procedure"](#).

# NOISE, VIBRATION AND HARSHNESS (NVH) TROUBLESHOOTING

< SYMPTOM DIAGNOSIS >

## NOISE, VIBRATION AND HARSHNESS (NVH) TROUBLESHOOTING

### NVH Troubleshooting Chart

INFOID:000000011373048

Use the chart below to find the cause of the symptom. If necessary, repair or replace these parts.

Symptom		Possible cause and SUSPECTED PARTS																	Reference page
		Improper installation, looseness	Out-of-round	Imbalance	Incorrect tire pressure	Uneven tire wear	Deformation or damage	Non-uniformity	Incorrect tire size	PROPELLER SHAFT (AWD)	DIFFERENTIAL (AWD)	FRONT AXLE AND FRONT SUSPENSION	REAR AXLE AND REAR SUSPENSION	TIRE	WHEELS	DRIVE SHAFT	BRAKE	STEERING	
TIRE	Noise	x	x	x	x	x	x	x		x	x	x	x		x	x	x	x	WT-65
	Shake	x	x	x	x	x	x		x	x		x	x		x	x	x	x	WT-65
	Vibration				x				x	x		x	x						WT-65
	Shimmy	x	x	x	x	x	x	x	x			x	x		x		x	x	WT-74
	Shudder	x	x	x	x	x	x		x			x	x		x		x	x	WT-65
	Poor quality ride or handling	x	x	x	x	x	x		x			x		x	x				
WHEEL	Noise	x	x	x			x			x	x	x	x	x		x	x	x	
	Shake	x	x	x			x			x		x	x	x		x	x	x	
	Shimmy, Shudder	x	x	x			x					x	x	x			x	x	
	Poor quality ride or handling	x	x	x			x					x	x	x					

x: Applicable

A  
B  
C  
D  
E  
F  
G  
H  
I  
J  
K  
L  
M  
N  
O  
P

WT

# WHEEL

< PERIODIC MAINTENANCE >

## PERIODIC MAINTENANCE

### WHEEL

#### Inspection

INFOID:000000011241753

#### WHEEL

1. Check tires for wear and improper inflation.
2. Check wheels for deformation, cracks and other damage. If deformed, remove wheel and check wheel runout.
3. Remove tire from wheel and mount wheel on a balancer machine.

**CAUTION:**

**DO NOT use center hole cone-type clamping machines to hold wheel during tire removal/installation or balancing; damage to wheel paint, cladding or chrome may result. Use only rim-type or universal lug-type clamping machines to hold wheel during servicing.**

- a. Set dial indicator as shown.
- b. Check runout. If runout value exceeds limit, replace wheel.

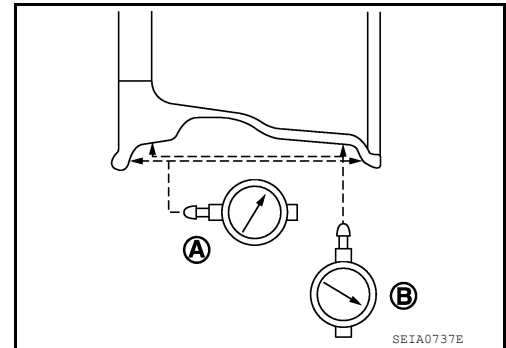

**Limit**

**Axial Runout (A)** Refer to [WT-74, "Wheel"](#).

**Radial Runout (B)** Refer to [WT-74, "Wheel"](#).



# WHEEL AND TIRE

< PERIODIC MAINTENANCE >

## WHEEL AND TIRE

### Balancing Wheels

INFOID:000000011241754

#### BALANCING WHEELS (ADHESIVE WEIGHT TYPE)

##### Preparation Before Adjustment

Remove inner and outer balance weights from wheel. Using releasing agent, remove double-faced adhesive tape from wheel and tire.

##### **CAUTION:**

- **Be careful not to scratch wheel and tire during removal.**
- **After removing double-faced adhesive tape, wipe clean all traces of releasing agent from wheel and tire.**

##### Wheel Balance Adjustment

##### **CAUTION:**

- **DO NOT use center hole cone-type clamping machines to hold wheel during tire removal/installation or balancing; damage to wheel paint, cladding or chrome may result. Use only rim-type or universal lug-type clamping machines to hold wheel during servicing.**

- If a balancer machine has an adhesive weight mode setting, select the adhesive weight mode setting and skip Step 2 below. If a balancer machine only has the clip-on (rim flange) weight mode setting, follow Step 2 to calculate correct size adhesive weight.

1. Set wheel and tire on balancer machine using center hole as a guide. Start balancer machine.
2. For balancer machines that only have a clip-on (rim flange) weight mode setting, follow this step to calculate correct size adhesive weight to use. When inner and outer imbalance values are shown on balancer machine indicator, multiply outer imbalance value by 5/3 (1.67) to determine balance weight that should be used. Select outer balance weight with a value closest to calculated value above and install into designated outer position of or at designated angle in relation to the wheel and tire.

- a. Indicated imbalance value  $\times 5/3$  (1.67) = balance weight to be installed

##### **Calculation example:**

23 g (0.81 oz)  $\times 5/3$  (1.67) = 38.33 g (1.35 oz)  $\Rightarrow$  40 g (1.41 oz)  
balance weight (closer to calculated balance weight value)

##### **NOTE:**

Note that balance weight value must be closer to calculated balance weight value.

##### **Example:**

37.4  $\Rightarrow$  35 g (1.23 oz)

37.5  $\Rightarrow$  40 g (1.41 oz)

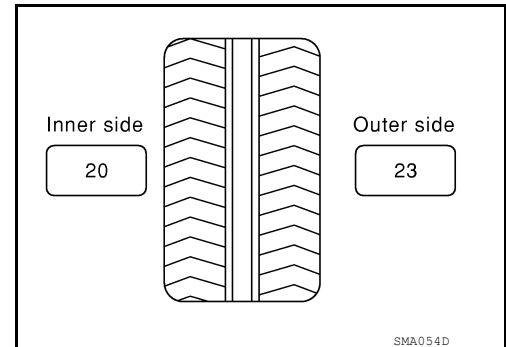

# WHEEL AND TIRE

## < PERIODIC MAINTENANCE >

3. Install balance weight in position shown.

**CAUTION:**

- Do not install inner balance weight before installing outer balance weight.
- Before installing balance weight, be sure to clean mating surface of wheel and tire.
- When installing balance weight (1) to wheel and tire, set it into grooved area (A) on inner wall of wheel and tire as shown so that balance weight center (B) is aligned with balancer machine indication position (angle) (C).

**CAUTION:**

- Always use Genuine NISSAN adhesive balance weights.
- Balance weights are non-reusable; always replace with new ones.
- Do not install more than three sheets of balance weights.

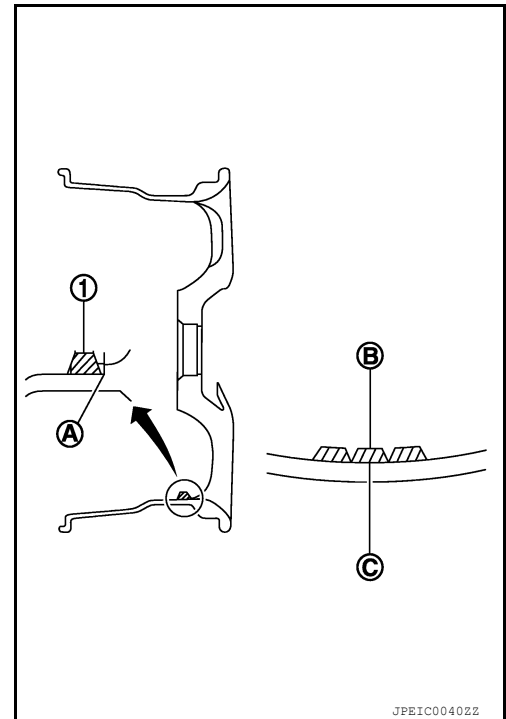

4. If calculated balance weight value exceeds 50 g (1.76 oz), install two balance weight sheets in line with each other as shown.

**CAUTION:**

**Do not install one balance weight sheet on top of another.**

5. Start balancer machine again.

6. Install balance weight on inner side of wheel and tire in the balancer machine indication position (angle).

**CAUTION:**

**Do not install more than two balance weights.**

7. Start balancer machine. Make sure that inner and outer residual imbalance values are 5 g (0.17 oz) each or below.

8. If either residual imbalance value exceeds 5 g (0.17 oz), repeat installation procedures.

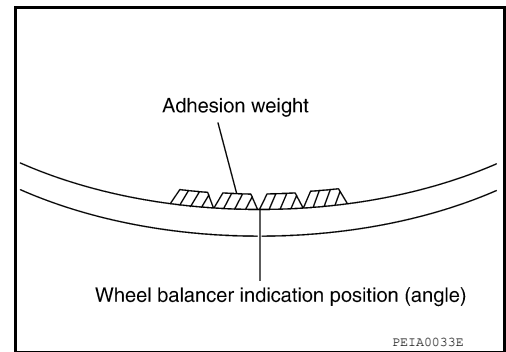

Wheel balance	Dynamic (At flange)	Static (At flange)
Maximum allowable imbalance	Refer to <a href="#">WT-74, "Wheel"</a> .	

## Rotation

INFOID:000000011565155

### TIRE ROTATION

- Follow maintenance schedule for tire rotation service intervals. Refer to [MA-7, "Introduction of Periodic Maintenance"](#).
- Rotate wheels and tires front to back in pattern as shown.
- When installing wheel, tighten wheel nuts to specified torque. Refer to [WT-68, "Exploded View"](#).

**WARNING:**

- Do not include spare tire when rotating tires.
- After rotating tires, check and adjust tire pressure.

**CAUTION:**

- When installing wheel nuts, tighten them diagonally by dividing the work two to three times in order to prevent wheels from developing any distortion.
- Be careful not to tighten wheel nuts to a torque exceeding specification to prevent strain on disc brake rotor.

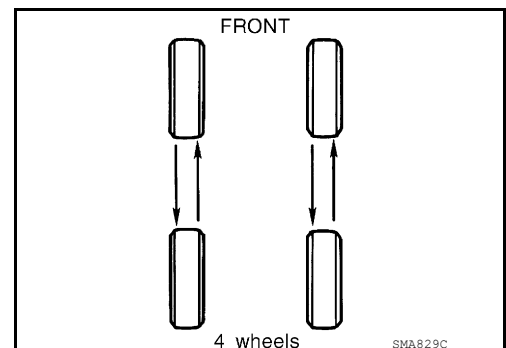

## WHEEL AND TIRE

< PERIODIC MAINTENANCE >

---

- Use Genuine NISSAN wheel nuts.

Wheel nut tightening torque : Refer to [WT-68, "Exploded View"](#).

- Perform ID registration after tire rotation. Refer to [WT-25, "Work Procedure"](#).

A

B

C

D

WT

F

G

H

I

J

K

L

M

N

O

P

# WHEEL AND TIRE

< REMOVAL AND INSTALLATION >

## REMOVAL AND INSTALLATION

### WHEEL AND TIRE

Exploded View

INFOID:000000011241755

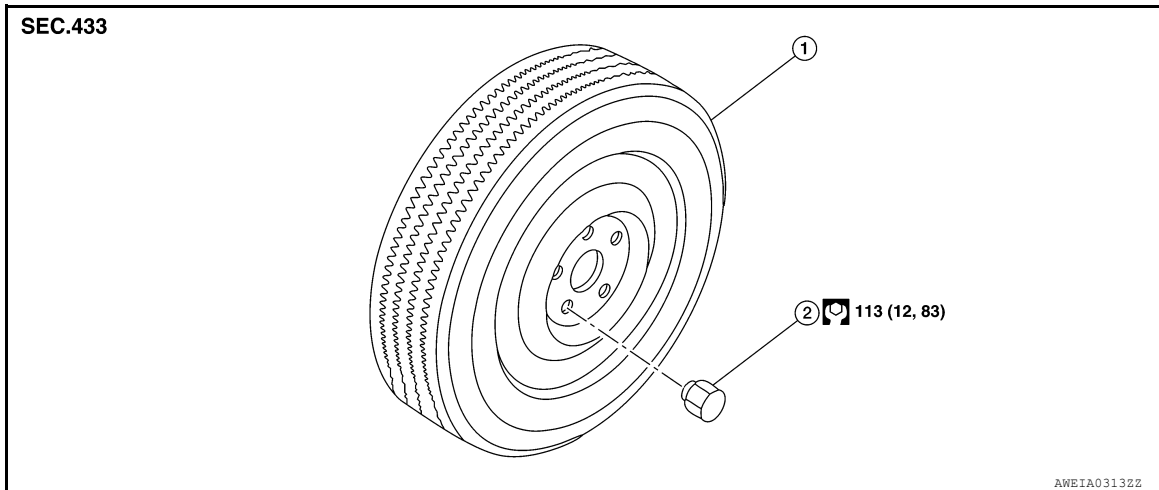

1. Wheel and tire

2. Wheel nut

### Removal and Installation

INFOID:000000011241756

#### REMOVAL

1. Remove wheel nuts using power tool.
2. Remove wheel and tire.

#### INSTALLATION

Installation is in reverse order of removal.

#### **CAUTION:**

- When installing wheel nuts, tighten them diagonally by dividing the work two or three times in order to prevent wheels from developing any distortion.
- Be careful not to tighten wheel nuts to a torque exceeding specification to prevent strain on disc brake rotor.
- Use Genuine NISSAN wheel nuts.

# TIRE PRESSURE SENSOR

< REMOVAL AND INSTALLATION >

## TIRE PRESSURE SENSOR

Exploded View

INFOID:0000000011241757

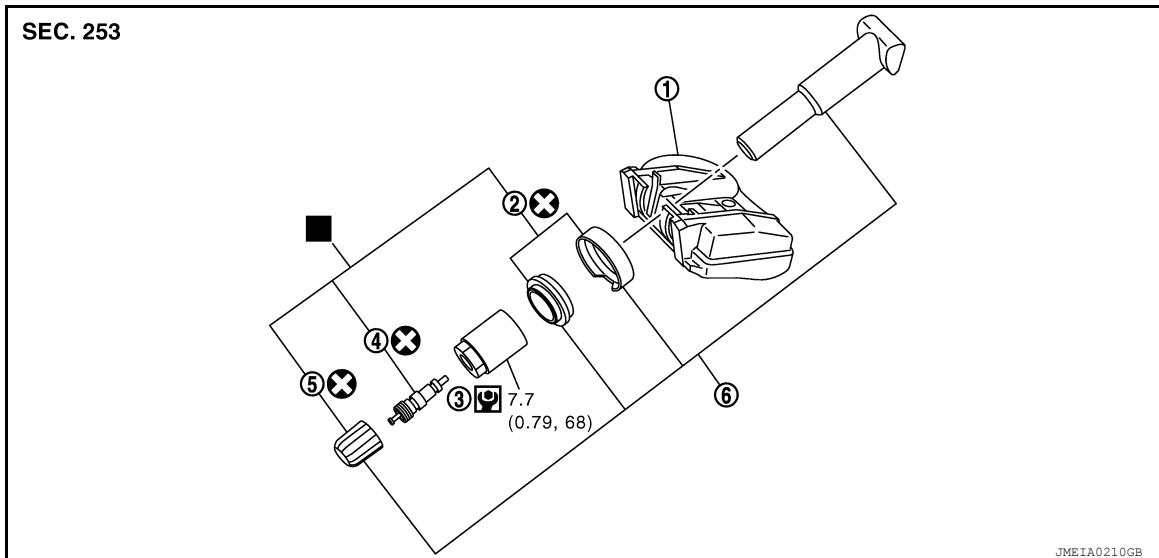

- |                         |                         |                        |
|-------------------------|-------------------------|------------------------|
| 1. Tire pressure sensor | 2. Washer/ Grommet seal | 3. Valve stem nut      |
| 4. Valve core           | 5. Valve cap            | 6. Valve stem assembly |
- : Parts that are replaced as a set when the tire is replaced.

## Removal and Installation

INFOID:0000000011241758

### REMOVAL

1. Remove wheel and tire using power tool. Refer to [WT-68, "Removal and Installation"](#).
2. Remove valve cap and valve core to deflate tire.

#### NOTE:

If tire is to be reused, apply a matching mark on tire in line with position of valve stem assembly for the purpose of wheel and tire balance adjustment after installation.

3. Remove valve stem nut and allow tire pressure sensor (1) to fall into tire.
4. Lubricate tire outside bead well with a suitable non-silicone lubricant, and remove outside of tire from wheel.

#### CAUTION:

- Do not use silicone lubricant. Use of silicone lubricant will deteriorate tire and wheel.
- Be sure not to damage wheel or tire pressure sensor.
- Do not allow lubricant to make contact with tire pressure sensor.
- Verify that tire pressure sensor is at bottom of tire while performing above.

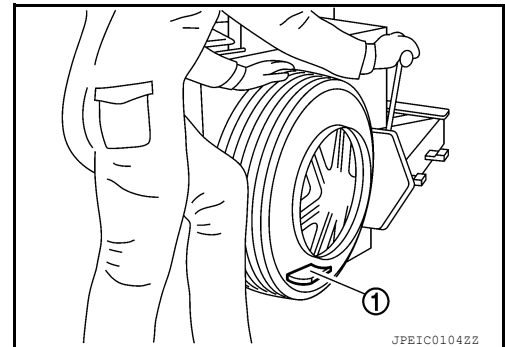

5. Lubricate tire inside bead well with a suitable non-silicone lubricant, and remove inside of tire from wheel.  
**CAUTION:**
  - Do not use silicone lubricant. Use of silicone lubricant will deteriorate tire and wheel.
  - Be sure not to damage wheel.
6. Set tire onto tire changer turntable so that tire pressure sensor inside tire is located close to valve stem hole in wheel.

# TIRE PRESSURE SENSOR

## < REMOVAL AND INSTALLATION >

- Turn tire so that valve stem hole in wheel is at bottom and bounce so that tire pressure sensor (1) inside tire is near valve stem hole in wheel. Carefully lift tire onto turn table and position valve stem hole in wheel (and tire pressure sensor) 270 degrees from mounting/dismounting head (2).

**CAUTION:**

**Do not damage wheel or tire pressure sensor.**

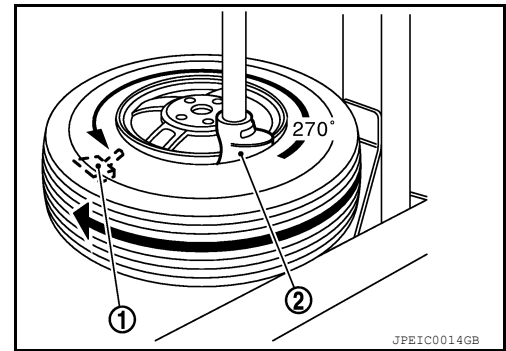

- Remove tire pressure sensor from tire.
- Remove grommet seal and washer.
- Remove valve stem in direction shown by arrow (←).

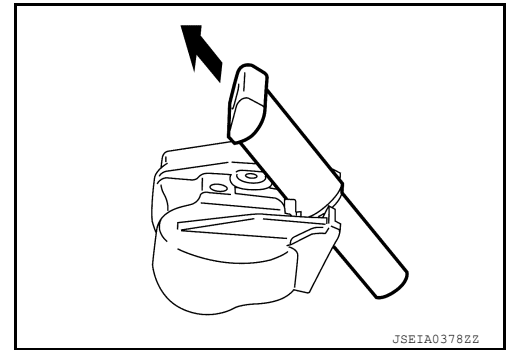

## INSTALLATION

- Apply a suitable non-silicone lubricant to tire inside bead.

**CAUTION:**

- Replace valve stem assembly if valve stem assembly has deformations, cracks, damage, or corrosion.
- Do not use silicone lubricant. Use of silicone lubricant will deteriorate tire and wheel.
- Do not drop or strike tire pressure sensor. Replace tire pressure sensor if it has been dropped from higher than one meter.

- Install tire inside bead (1) onto wheel (2) in position shown.

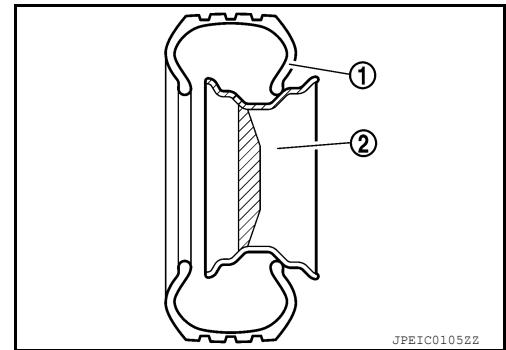

- Install valve stem to tire pressure sensor.
- Install washer (1) onto valve stem and then install grommet seal (2) onto valve stem.

**CAUTION:**

- Do not reuse grommet seal or washer.
- Check direction of grommet seal.
- Insert grommet seal all the way to the base.

↑ : Outside

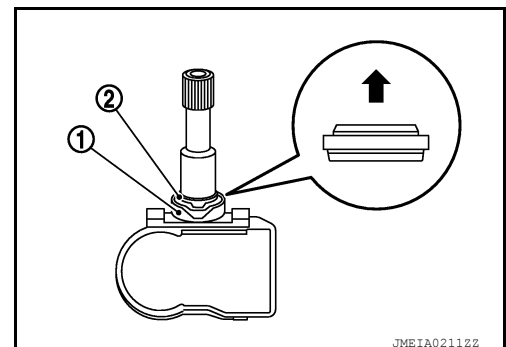

# TIRE PRESSURE SENSOR

## < REMOVAL AND INSTALLATION >

### CAUTION:

Direct cut part (A) of washer to center of valve stem as shown.

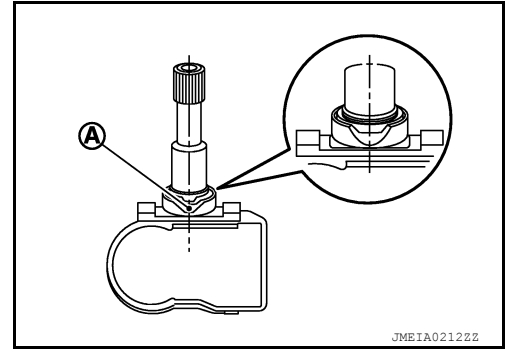

5. Follow procedure below and install tire pressure sensor to wheel.
- a. Check position of valve stem (A) before installing tire pressure sensor to wheel.

### CAUTION:

The base of the valve stem must be positioned in the groove of the metal plate as shown.

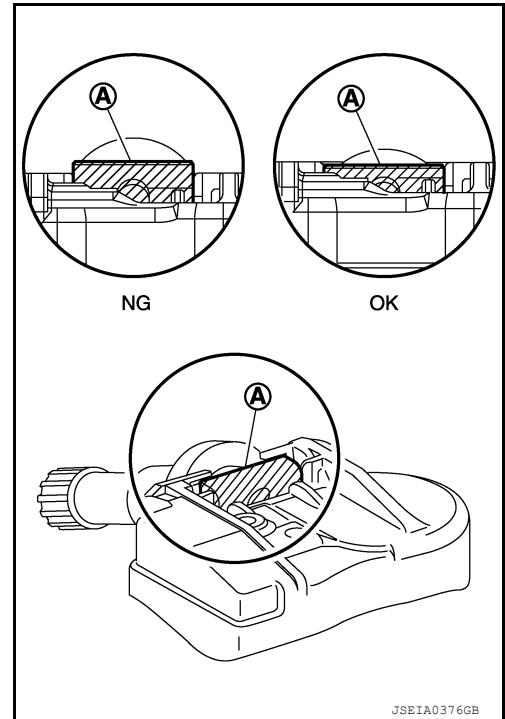

- b. Hold tire pressure sensor as shown and press tire pressure sensor in direction shown by arrow (←) to bring into absolute contact with wheel. Tighten valve stem nut to specified torque.

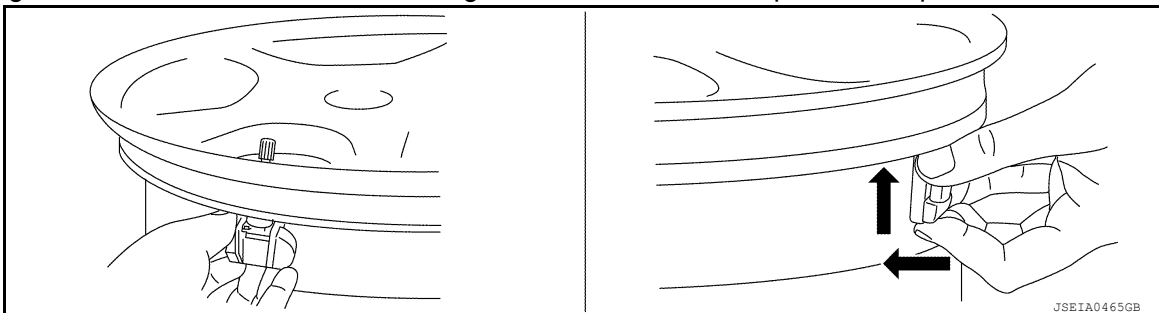

Valve stem nut tightening torque : Refer to [WT-69, "Exploded View"](#).

### CAUTION:

- Do not reuse valve core and valve cap.
- Check that grommet seal is free of foreign matter.
- Check that grommet seal contacts horizontally with wheel.
- Check again that base of valve stem is positioned in groove of metal plate.
- Manually tighten valve stem nut all the way to wheel. (Do not use a power tool to avoid impact.)

# TIRE PRESSURE SENSOR

## < REMOVAL AND INSTALLATION >

- Do not tighten valve stem nut to more than specified torque. It may cause grommet seal damage.
- Do not tighten valve stem nut to less than specified torque. It may cause an air leak.

6. Place wheel on turntable of tire machine. Ensure that tire pressure sensor (1) is 270 degrees from mounting/dismounting head (2).

**CAUTION:**

Do not touch tire pressure sensor with mounting head.

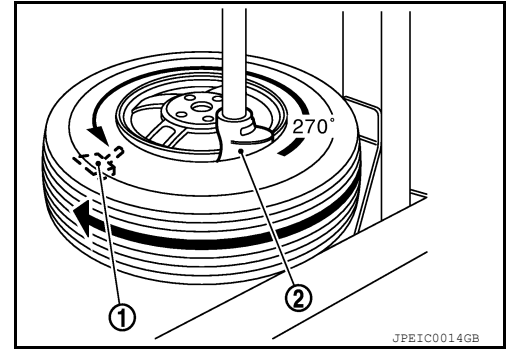

7. Apply a suitable non-silicone lubricant to tire outside bead.

**CAUTION:**

- Do not use silicone lubricant. Use of silicone lubricant will deteriorate tire and wheel.
- Do not allow lubricant to make contact with tire pressure sensor.
- When installing, check that tire does not turn together with wheel.

8. Install tire outside bead onto wheel as normal.

**NOTE:**

If tire is being reused, align matching mark applied on tire with position of valve stem assembly for purpose of wheel and tire balance adjustment after installation. Make sure that tire does not rotate relative to wheel.

9. Install valve core and inflate tire. Refer to [WT-74, "Tire Air Pressure"](#).

**CAUTION:**

Do not reuse valve core.

10. Install valve cap.

**CAUTION:**

Do not reuse valve cap.

11. Balance wheel and tire. Refer to [WT-65, "Balancing Wheels"](#).

12. Install wheel and tire in the appropriate position on vehicle. Refer to [WT-68, "Removal and Installation"](#).

13. Perform the ID registration procedure. Refer to [WT-25, "Work Procedure"](#).

**NOTE:**

If replacing tire pressure sensor, then ID registration procedure must be performed.

## Disposal

INFOID:000000011545079

**CAUTION:**

- When discarding tire pressure sensor, remove battery (1) from tire pressure sensor.
- Dispose of battery according to the law and local regulations.

1. Remove battery from tire pressure sensor.

**NOTE:**

The battery is sealed to tire pressure sensor with urethane.

- a. Remove urethane from tire pressure sensor.

- b. Using a suitable tool, cut battery terminal (A), then remove battery from tire pressure sensor.

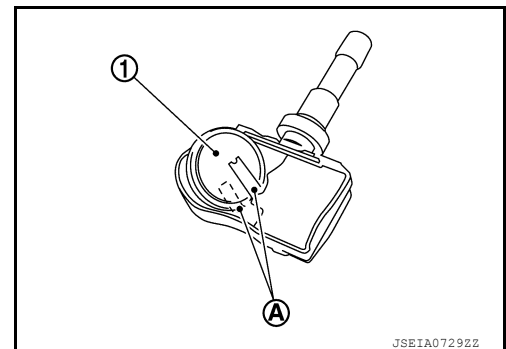



# REMOTE KEYLESS ENTRY RECEIVER

< REMOVAL AND INSTALLATION >

---

## REMOTE KEYLESS ENTRY RECEIVER

### Removal and Installation

INFOID:000000011241759

The Tire Pressure Receiver is an integral part of the Remote Keyless Entry Receiver. Refer to [DLK-309](#), "[Removal and Installation](#)".

A  
B  
C  
D  
E  
F  
G  
H  
I  
J  
K  
L  
M  
N  
O  
P

WT

## SERVICE DATA AND SPECIFICATIONS (SDS)

< SERVICE DATA AND SPECIFICATIONS (SDS)

## SERVICE DATA AND SPECIFICATIONS (SDS)

### SERVICE DATA AND SPECIFICATIONS (SDS)

#### Wheel

INFOID:0000000011241760

Runout	Axial runout	Less than 0.3 mm (0.012 in)
	Radial runout	
Allowable imbalance	Dynamic (At flange)	Less than 5 g (0.17 oz) (one side)
	Static (At flange)	Less than 10 g (0.35 oz)

#### Tire Air Pressure

INFOID:0000000011241761

Unit: kPa (kg/cm<sup>2</sup>, psi)

Tire position	Size	Cold tire pressure
Front	235/65R18	230 (2.3, 33)
	235/55R20	240 (2.4, 35)
Rear	235/65R18	230 (2.3, 33)
	235/55R20	240 (2.4, 35)
Spare	T165/90D18	420 (4.2, 60)