

SECTION **DLN**
DRIVELINE

A
B
C

DLN

CONTENTS

E

TRANSFER: TY21C

PRECAUTION	5	ECU DIAGNOSIS INFORMATION	20
PRECAUTIONS	5	AWD CONTROL UNIT	20
Precaution for Supplemental Restraint System (SRS) "AIR BAG" and "SEAT BELT PRE-TENSIONER"	5	Reference Value	20
Precaution for Procedure without Cowl Top Cover.....	5	Fail-Safe	21
Precaution for Battery Service	5	Protection Function	22
Service Notice or Precautions for Transfer	5	DTC Inspection Priority Chart	22
PREPARATION	7	DTC Index	23
PREPARATION	7	WIRING DIAGRAM	24
Special Service Tool	7	AWD SYSTEM	24
Commercial Service Tool	7	Wiring Diagram	24
Lubricant or/and Sealant	9	BASIC INSPECTION	29
SYSTEM DESCRIPTION	10	DIAGNOSIS AND REPAIR WORK FLOW	29
COMPONENT PARTS	10	Work Flow	29
Component Parts Location	10	Diagnostic Work Sheet	30
AWD Control Unit	11	ADDITIONAL SERVICE WHEN REPLACING AWD CONTROL UNIT	32
AWD Solenoid	11	Description	32
Electric Controlled Coupling	11	Work Procedure	32
AWD Warning Icon/Display	11	UNIT CHARACTERISTICS WRITING	33
STRUCTURE AND OPERATION	13	Description	33
Sectional View	13	Work Procedure	33
Operation Description	14	DTC/CIRCUIT DIAGNOSIS	34
SYSTEM	15	C1201 AWD CONTROL UNIT	34
AWD SYSTEM	15	DTC Description	34
AWD SYSTEM : System Description	15	Diagnosis Procedure	34
AWD SYSTEM : Fail-Safe	16	C1203 ABS ACTUATOR AND ELECTRIC UNIT (CONTROL UNIT)	35
AWD SYSTEM : Protection Function	16	DTC Description	35
DIAGNOSIS SYSTEM (AWD CONTROL UNIT)	18	Diagnosis Procedure	35
CONSULT Function	18	C1204 AWD SOLENOID	36
		DTC Description	36
		Diagnosis Procedure	36

F

G

H

I

J

K

L

M

N

O

P

Component Inspection	38	TRANSFER OIL	56
C1205 AWD ACTUATOR RELAY	39	Inspection	56
DTC Description	39	Draining	56
Diagnosis Procedure	39	Refilling	56
C1210 ECM	41	REMOVAL AND INSTALLATION	58
DTC Description	41	AWD CONTROL UNIT	58
Diagnosis Procedure	41	Exploded View	58
P1804 AWD CONTROL UNIT	42	Removal and Installation	58
DTC Description	42	TRANSFER COVER OIL SEAL	59
Diagnosis Procedure	42	Removal and Installation	59
P181F INCOMPLETE CALIBRATION	43	UNIT REMOVAL AND INSTALLATION	60
DTC Description	43	TRANSFER ASSEMBLY	60
Diagnosis Procedure	43	Exploded View	60
U1000 CAN COMM CIRCUIT	44	Removal and Installation	60
DTC Description	44	UNIT DISASSEMBLY AND ASSEMBLY ...	62
Diagnosis Procedure	44	TRANSFER COVER	62
U1010 CONTROL UNIT (CAN)	45	Exploded View	62
DTC Description	45	Disassembly and Assembly	63
Diagnosis Procedure	45	Inspection	65
POWER SUPPLY AND GROUND CIRCUIT	46	RING GEAR SHAFT	66
Diagnosis Procedure	46	Exploded View	66
AWD WARNING ICON/DISPLAY	49	Disassembly and Assembly	67
Diagnosis Procedure	49	Inspection	69
SYMPTOM DIAGNOSIS	50	DRIVE PINION	71
AWD ERROR IS DISPLAYED ON INFORMA-		Exploded View	71
TION DISPLAY	50	Disassembly and Assembly	72
Description	50	Adjustment	74
Diagnosis Procedure	50	Inspection	78
HEAVY TIGHT-CORNER BRAKING SYMP-		TRANSFER CASE	79
TOM OCCURS	51	Exploded View	79
Description	51	Disassembly and Assembly	80
Diagnosis Procedure	51	Inspection	82
VEHICLE DOES NOT ENTER AWD MODE	52	SERVICE DATA AND SPECIFICATIONS	
Description	52	(SDS)	83
Diagnosis Procedure	52	SERVICE DATA AND SPECIFICATIONS	
AWD HIGH TEMP IS DISPLAYED ON INFOR-		(SDS)	83
MATION DISPLAY	53	General Specifications	83
Description	53	Preload Torque	83
TIRE SIZE INCORRECT IS DISPLAYED ON		Backlash	83
INFORMATION DISPLAY	54	Companion Flange Runout	83
Description	54	REAR PROPELLER SHAFT: C-CVJ-C	
Diagnosis Procedure	54	PRECAUTION	84
NOISE, VIBRATION AND HARSHNESS		PRECAUTIONS	84
(NVH) TROUBLESHOOTING	55	Precaution for Supplemental Restraint System	
NVH Troubleshooting Chart	55	(SRS) "AIR BAG" and "SEAT BELT PRE-TEN-	
PERIODIC MAINTENANCE	56	SIONER"	84
		Service Notice or Precautions for Propeller Shaft...	84

PREPARATION	85	NOISE, VIBRATION AND HARSHNESS (NVH) TROUBLESHOOTING	102	A
PREPARATION	85	NVH Troubleshooting Chart	102	
Commercial Service Tool	85	PERIODIC MAINTENANCE	103	B
SYSTEM DESCRIPTION	86	REAR DIFFERENTIAL GEAR OIL	103	
STRUCTURE AND OPERATION	86	Inspection	103	C
Sectional View	86	Draining	103	
SYMPTOM DIAGNOSIS	87	Refilling	103	
NOISE, VIBRATION AND HARSHNESS (NVH) TROUBLESHOOTING	87	REMOVAL AND INSTALLATION	104	DLN
NVH Troubleshooting Chart	87	DRIVE PINION OIL SEAL	104	
PERIODIC MAINTENANCE	88	Exploded View	104	E
REAR PROPELLER SHAFT	88	Removal and Installation	104	
Inspection	88	Inspection	104	F
REMOVAL AND INSTALLATION	89	SIDE OIL SEAL	106	
REAR PROPELLER SHAFT	89	Exploded View	106	G
Exploded View	89	Removal and Installation	106	
Removal and Installation	89	Inspection	107	H
Inspection	92	ELECTRIC CONTROLLED COUPLING	108	
SERVICE DATA AND SPECIFICATIONS (SDS)	94	Exploded View	108	I
SERVICE DATA AND SPECIFICATIONS (SDS)	94	Removal and Installation	108	
General Specifications	94	Inspection and Adjustment	112	J
Propeller Shaft Runout	94	AIR BREATHER	113	
Journal Axial Play	94	Exploded View	113	K
REAR FINAL DRIVE: R145		Removal and Installation	113	
PRECAUTION	95	UNIT REMOVAL AND INSTALLATION ...	116	L
PRECAUTIONS	95	REAR FINAL DRIVE ASSEMBLY	116	
Precaution for Supplemental Restraint System (SRS) "AIR BAG" and "SEAT BELT PRE-TENSIONER"	95	Exploded View	116	M
Precautions for Removing Battery Terminal	95	Removal and Installation	116	
Service Notice or Precautions for Rear Final Drive... ..	96	Inspection and Adjustment	118	N
PREPARATION	97	UNIT DISASSEMBLY AND ASSEMBLY .	119	
PREPARATION	97	ELECTRIC CONTROLLED COUPLING	119	
Special Service Tools	97	Exploded View	119	O
Commercial Service Tools	99	Disassembly and Assembly	120	
Lubricant or/and Sealant	100	DIFFERENTIAL ASSEMBLY	123	
SYSTEM DESCRIPTION	101	Exploded View	123	P
STRUCTURE AND OPERATION	101	Disassembly and Assembly	124	
Sectional View	101	Adjustment	129	
Electric Controlled Coupling	101	Inspection	133	
SYMPTOM DIAGNOSIS	102	DRIVE PINION	134	
		Exploded View	134	
		Disassembly and Assembly	135	
		Inspection	139	
		SERVICE DATA AND SPECIFICATIONS (SDS)	140	
		SERVICE DATA AND SPECIFICATIONS (SDS)	140	
		General Specifications	140	

Preload Torque	140	Backlash	140
Drive Gear Runout	140	Differential Side Gear Clearance	140

PRECAUTION

PRECAUTIONS

Precaution for Supplemental Restraint System (SRS) "AIR BAG" and "SEAT BELT PRE-TENSIONER"

INFOID:000000012892848

The Supplemental Restraint System such as "AIR BAG" and "SEAT BELT PRE-TENSIONER", used along with a front seat belt, helps to reduce the risk or severity of injury to the driver and front passenger for certain types of collision. Information necessary to service the system safely is included in the SR and SB section of this Service Manual.

WARNING:

- To avoid rendering the SRS inoperative, which could increase the risk of personal injury or death in the event of a collision which would result in air bag inflation, it is recommended that all maintenance and repair be performed by an authorized NISSAN/INFINITI dealer.
- Improper repair, including incorrect removal and installation of the SRS, can lead to personal injury caused by unintentional activation of the system. For removal of Spiral Cable and Air Bag Module, see the SR section.
- Do not use electrical test equipment on any circuit related to the SRS unless instructed to in this Service Manual. SRS wiring harnesses can be identified by yellow and/or orange harnesses or harness connectors.

PRECAUTIONS WHEN USING POWER TOOLS (AIR OR ELECTRIC) AND HAMMERS

WARNING:

- When working near the Air Bag Diagnosis Sensor Unit or other Air Bag System sensors with the Ignition ON or engine running, DO NOT use air or electric power tools or strike near the sensor(s) with a hammer. Heavy vibration could activate the sensor(s) and deploy the air bag(s), possibly causing serious injury.
- When using air or electric power tools or hammers, always switch the Ignition OFF, disconnect the battery or batteries, and wait at least three minutes before performing any service.

Precaution for Procedure without Cowl Top Cover

INFOID:000000012892849

When performing the procedure after removing cowl top cover, cover the lower end of windshield with urethane, etc to prevent damage to windshield.

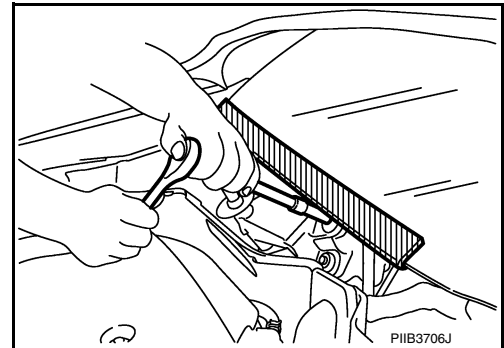

Precaution for Battery Service

INFOID:000000012892850

Before disconnecting the battery, lower both the driver and passenger windows. This will prevent any interference between the window edge and the vehicle when the door is opened/closed. During normal operation, the window slightly raises and lowers automatically to prevent any window to vehicle interference. The automatic window function will not work with the battery disconnected.

Service Notice or Precautions for Transfer

INFOID:000000012892851

- After overhaul refill the transfer with new transfer oil.
- Check the oil level or replace the oil only with the vehicle parked on level surface.
- During removal or installation, keep inside of transfer clear of dust or dirt.
- Replace all tires at the same time. Always use tires of the proper size and the same brand and pattern. Fitting improper size and unusual wear tires applies excessive force to vehicle mechanism and can cause longitudinal vibration.
- Disassembly should be done in a clean work area.

A
B
C
DLN
E
F
G
H
I
J
K
L
M
N
O
P

PRECAUTIONS

< PRECAUTION >

[TRANSFER: TY21C]

- Before proceeding with disassembly, thoroughly clean the transfer. It is important to prevent the internal parts from becoming contaminated by dirt or other foreign matter.
- Check for the correct installation status prior to removal or disassembly. If matching marks are required, be certain they do not interfere with the function of the parts when applied.
- All parts should be carefully cleaned with a general purpose, non-flammable solvent before inspection or reassembly.
- Check appearance of the disassembled parts for damage, deformation, and unusual wear. Replace them with a new one if necessary.
- Gaskets, seals, O-rings and lock nuts should be replaced any time when the transfer is disassembled.
- In principle, tighten bolts or nuts gradually in several steps working diagonally from inside to outside. If tightening sequence is specified, use it.
- Observe the specified torque when assembling.
- Clean and flush the parts sufficiently and blow-dry them.
- Be careful not to damage sliding surfaces and mating surfaces.
- Use lint-free cloth or towels for wiping parts clean. Common shop rags can leave fibers that could interfere with the operation of the transfer.

PREPARATION

< PREPARATION >

[TRANSFER: TY21C]

PREPARATION

PREPARATION

Special Service Tool

INFOID:0000000012892852

The actual shape of the tools may differ from those illustrated here.

Tool number (TechMate No.) Tool name	Description
ST33061000 (J-8107-2) Drift a: 38 mm (1.50 in) dia. b: 28.5 mm (1.122 in) dia.	Removing ring gear bearing (left) inner race (transfer case side)
KV381054S0 (J-34286) Puller	Removing ring gear shaft oil seal
ST3127S000 (J-25765-A) Preload gauge	Measuring preload torque

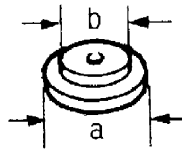

ZZA0810D

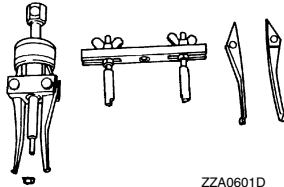

ZZA0601D

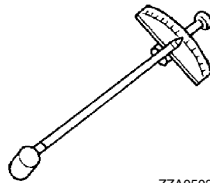

ZZA0503D

Commercial Service Tool

INFOID:0000000012892853

Tool name	Description
Power tool	Loosening nuts, screws and bolts
Drift a: 52 mm (2.05 in) dia. b: 44 mm (1.73 in) dia.	Removing gear ring bearing inner race (adapter case side)



PIIB1407E

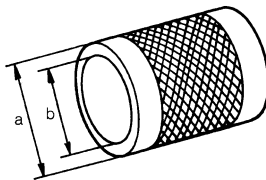

ZZA1002D

PREPARATION

< PREPARATION >

[TRANSFER: TY21C]

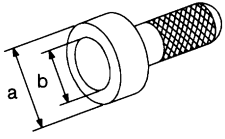
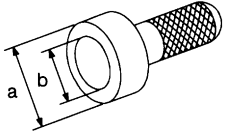
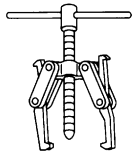
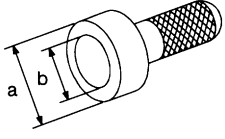
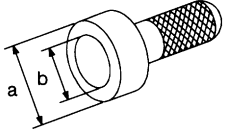
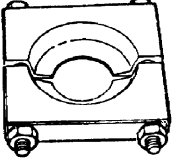
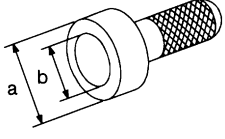
Tool name	Description
<p>Drift a: 56.5 mm (2.224 in) dia. b: 48 mm (1.89 in) dia.</p>  <p style="text-align: center;">NT115</p>	<p>Installing side oil seal (installing transfer case oil seal)</p>
<p>Drift a: 44 mm (1.73 in) dia. b: 33 mm (1.3 in) dia.</p>  <p style="text-align: center;">NT115</p>	<p>Installing ring gear shaft oil seal</p>
<p>Puller</p>  <p style="text-align: center;">NT077</p>	<p>Removing ring gear bearing (left) inner race (transfer case side)</p>
<p>Drift a: 70 mm (2.76 in) dia. b: 60 mm (2.36 in) dia.</p>  <p style="text-align: center;">NT115</p>	<p>Installing oil seal (installing pinion bearing seal)</p>
<p>Drift a: 78 mm (3.07 in) dia. b: 68 mm (2.68 in) dia.</p>  <p style="text-align: center;">NT115</p>	<p>Installing side oil seal (installing transfer cover oil seal)</p>
<p>Replacer</p>  <p style="text-align: center;">ZZA0700D</p>	<ul style="list-style-type: none"> • Removing drive pinion • Removing ring gear bearing (left) inner race (transfer cover side)
<p>Drift a: 58 mm (2.28 in) dia. b: 55 mm (2.17 in) dia.</p>  <p style="text-align: center;">NT115</p>	<p>Installing ring gear bearing (left) inner race (transfer case side)</p>

PREPARATION

< PREPARATION >

[TRANSFER: TY21C]

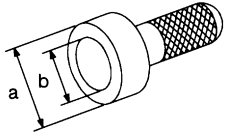
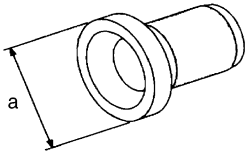
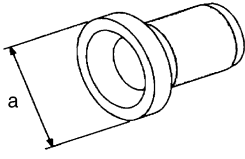
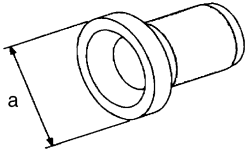
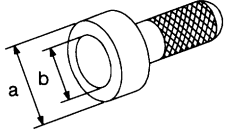
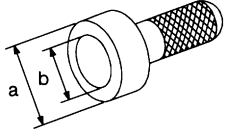
Tool name	Description
Drift a: 62 mm (2.44 in) dia. b: 58 mm (2.28 in) dia. <div style="text-align: center;">  <p>NT115</p> </div>	Installing ring gear bearing (right) inner race (transfer cover side)
Drift a: 73.5 mm (2.894 in) dia. <div style="text-align: center;">  <p>SCIA5338E</p> </div>	Installing ring gear bearing (left) outer race (transfer case side)
Drift a: 87 mm (3.43 in) dia. <div style="text-align: center;">  <p>SCIA5338E</p> </div>	Installing ring gear bearing (right) outer race (transfer cover side)
Drift a: 20 mm (0.79 in) dia. <div style="text-align: center;">  <p>SCIA5338E</p> </div>	Removing drive pinion
Drift a: 50 mm (1.97 in) dia. b: 41 mm (1.61 in) dia. <div style="text-align: center;">  <p>NT115</p> </div>	Installing pinion bearing
Drift a: 40 mm (1.57 in) dia. b: 25 mm (0.98 in) dia. <div style="text-align: center;">  <p>NT115</p> </div>	Installing companion flange

A
 B
 C
DLN
 E
 F
 G
 H
 I
 J
 K
 L
 M
 N
 O
 P

Lubricant or/and Sealant

INFOID:0000000012892854

Item	Use
Red lead or equivalent	Checking tooth contact

COMPONENT PARTS

< SYSTEM DESCRIPTION >

[TRANSFER: TY21C]

SYSTEM DESCRIPTION

COMPONENT PARTS

Component Parts Location

INFOID:000000012892855

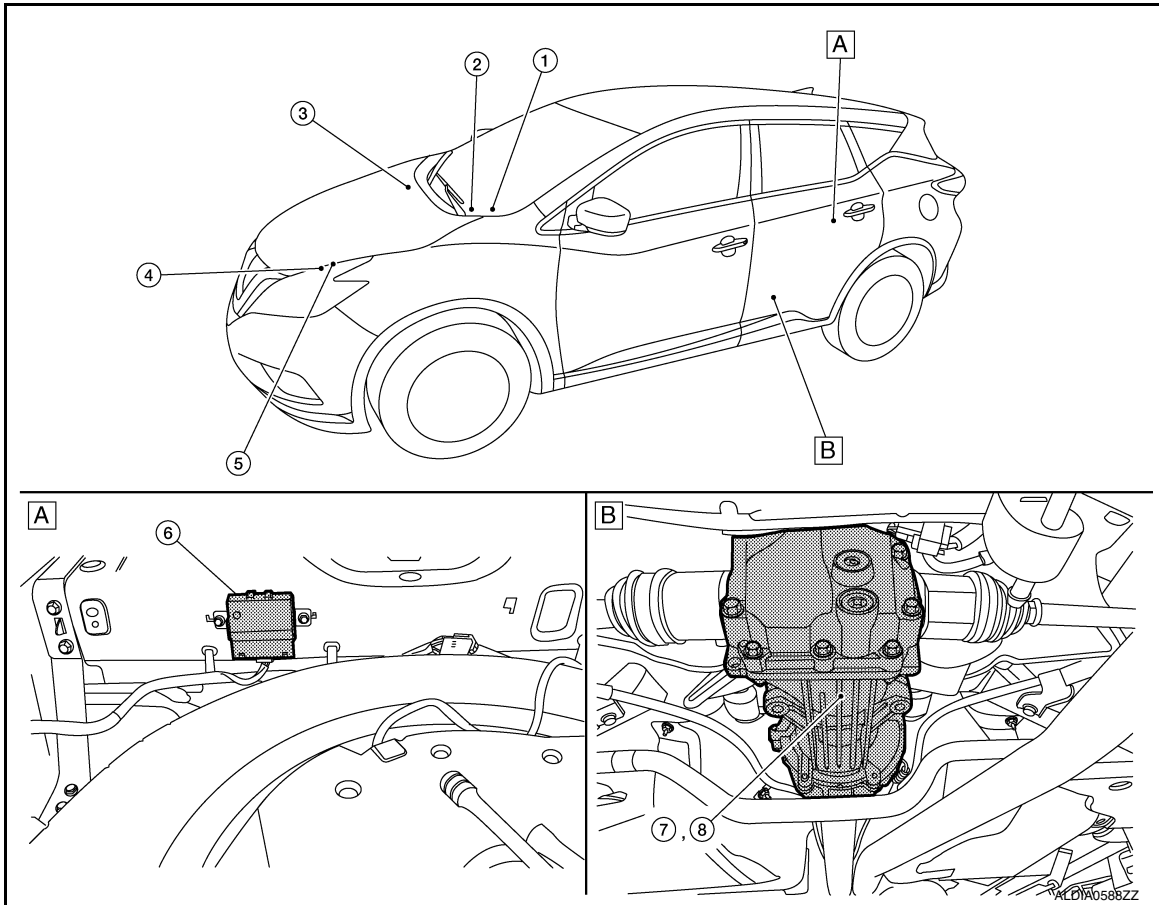

A Inside storage room

B Rear final drive

No.	Component	Function
①	Steering angle sensor	Mainly transmits the following signal to AWD control unit via CAN communication: <ul style="list-style-type: none"> Steering angle sensor signal For detailed installation location, refer to BRC-180. "Component Parts Location" .
②	Combination meter (AWD warning icon/display)	Mainly transmits the following signal to AWD control unit via CAN communication: <ul style="list-style-type: none"> Parking brake switch signal Mainly receives the following signal from AWD control unit via CAN communication. <ul style="list-style-type: none"> AWD warning icon/display signal For detailed installation location, refer to MWI-5. "METER SYSTEM : Component Parts Location" .

COMPONENT PARTS

< SYSTEM DESCRIPTION >

[TRANSFER: TY21C]

No.	Component	Function
③	ABS actuator and electric unit (control unit)	Mainly transmits the following signals to AWD control unit via CAN communication: <ul style="list-style-type: none"> • Vehicle speed signal • Stop lamp switch signal (brake signal) • Yaw rate sensor signal • Side G sensor signal • Decel G sensor signal For detailed installation location, refer to BRC-180, "Component Parts Location" .
④	ECM	Mainly transmits the following signals to AWD control unit via CAN communication: <ul style="list-style-type: none"> • Accelerator pedal position signal • Engine speed signal For detailed installation location, refer to EC-15, "ENGINE CONTROL SYSTEM : Component Parts Location" .
⑤	TCM	Mainly transmits the following signals to AWD control unit via CAN communication: <ul style="list-style-type: none"> • Input shaft revolutionary signal • CVT ratio signal For detailed installation location, refer to TM-11, "CVT CONTROL SYSTEM : Component Parts Location" .
⑥	AWD control unit	Refer to DLN-11, "AWD Control Unit" .
⑦	Electric controlled coupling	Refer to DLN-11, "Electric Controlled Coupling" .
⑧	AWD solenoid	Refer to DLN-11, "AWD Solenoid" .

AWD Control Unit

INFOID:000000012892856

- Controls driving force distribution by signals from each sensor from front wheel driving mode (100:0) to 4-wheel driving mode (50:50).
- Front wheel driving conditions is available by fail-safe function if malfunction is detected in AWD system.
- AWD actuator relay is integrated with AWD control unit, and supplies AWD solenoid with voltage.

AWD Solenoid

INFOID:000000012892857

Controls electric controlled coupling by command current from AWD control unit.

Electric Controlled Coupling

INFOID:000000012892858

Electric controlled coupling is integrated with rear final drive and transmits driving force to rear final drive. For operation, refer to [DLN-14, "Operation Description"](#).

AWD Warning Icon/Display

INFOID:000000012892859



AWD warning icon/display is displayed when there is a malfunction in AWD system. AWD warning icon/display indicates the vehicle is in fail-safe mode and shifting to front-wheel drive or 4-wheel drive (rear-wheels still have some driving torque).

AWD WARNING ICON/DISPLAY INDICATION

COMPONENT PARTS

< SYSTEM DESCRIPTION >

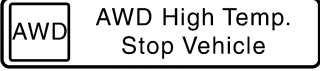
[TRANSFER: TY21C]

Condition	AWD warning icon/display
<p>AWD system malfunction</p>	<div style="text-align: center; border: 1px solid black; padding: 5px; width: fit-content; margin: 0 auto;">  </div> <p style="text-align: center; font-size: small; margin-top: 5px;">JSDIA3103GB</p>
<p>Protection function is activated due to heavy load to electric controlled coupling. (AWD system is not malfunctioning and AWD system changes to front wheel drive.) When this message is displayed, refer to DLN-53. "Description".</p>	<div style="text-align: center; border: 1px solid black; padding: 5px; width: fit-content; margin: 0 auto;">  </div> <p style="text-align: center; font-size: small; margin-top: 5px;">JSDIA3104GB</p> <p style="text-align: center;">(Displaying for approximately 1 minute and then turned OFF)</p>
<p>Large difference in diameter of front/rear tires When this message is displayed, refer to DLN-54. "Diagnosis Procedure".</p>	<div style="text-align: center; border: 1px solid black; padding: 5px; width: fit-content; margin: 0 auto;">  </div> <p style="text-align: center; font-size: small; margin-top: 5px;">JSDIA3105GB</p> <p style="text-align: center;">(Continuing to display until ignition switch is turned OFF)</p>
<p>Other than above (system normal)</p>	<p style="text-align: center;">OFF</p>

CAUTION:

- **AWD warning icon/display is displayed due to data reception error, CAN communication error etc.**

STRUCTURE AND OPERATION

< SYSTEM DESCRIPTION >

[TRANSFER: TY21C]

STRUCTURE AND OPERATION

Sectional View

INFOID:000000012892860

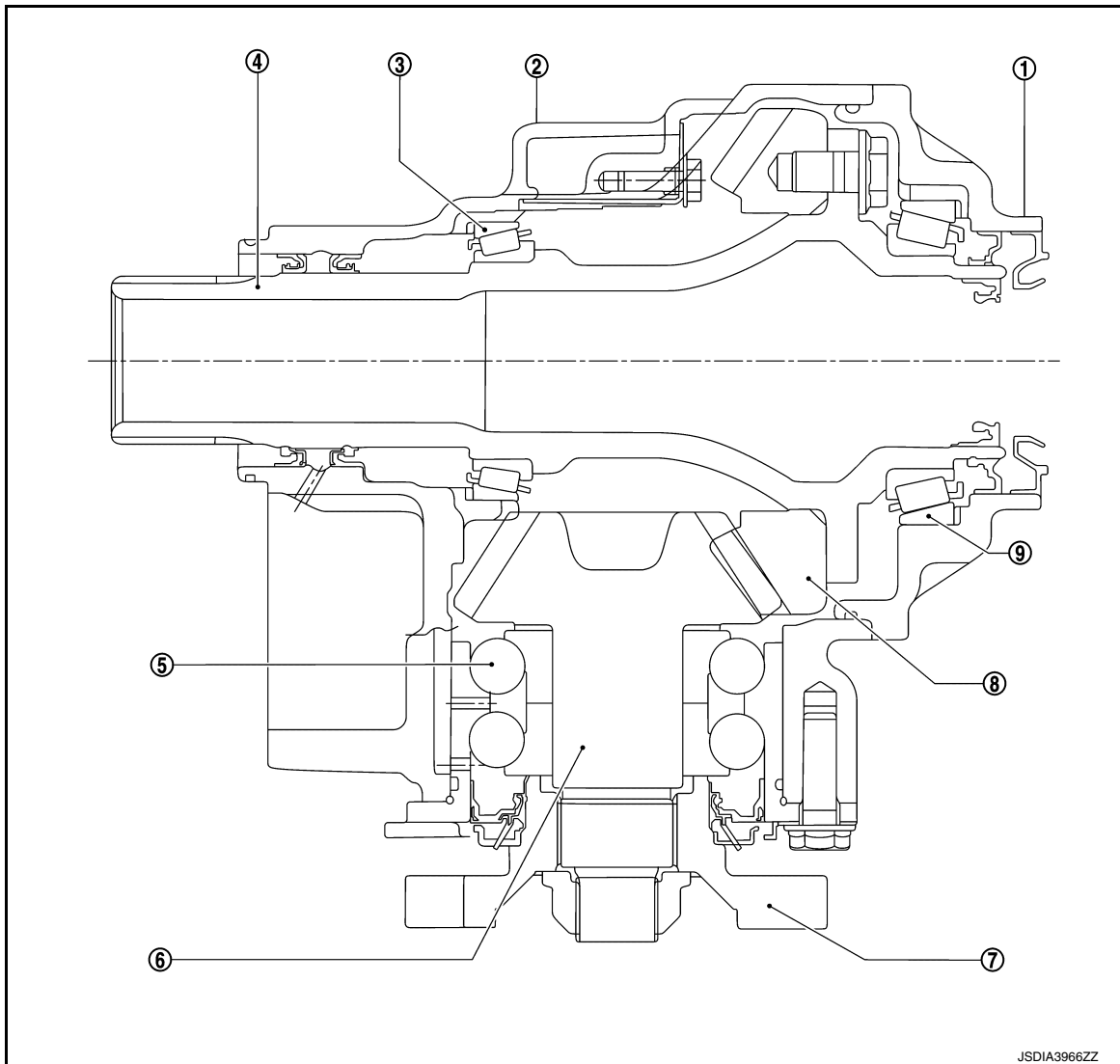

- | | | |
|--------------------|------------------|---|
| ① Transfer cover | ② Transfer case | ③ Ring gear bearing (transfer case side) |
| ④ Ring gear shaft | ⑤ Pinion bearing | ⑥ Drive pinion |
| ⑦ Companion flange | ⑧ Ring gear | ⑨ Ring gear bearing (transfer cover side) |

A
B
C
DLN
E
F
G
H
I
J
K
L
M
N
O
P

STRUCTURE AND OPERATION

< SYSTEM DESCRIPTION >

[TRANSFER: TY21C]

INFOID:000000012892861

Operation Description

POWER TRANSFER DIAGRAM

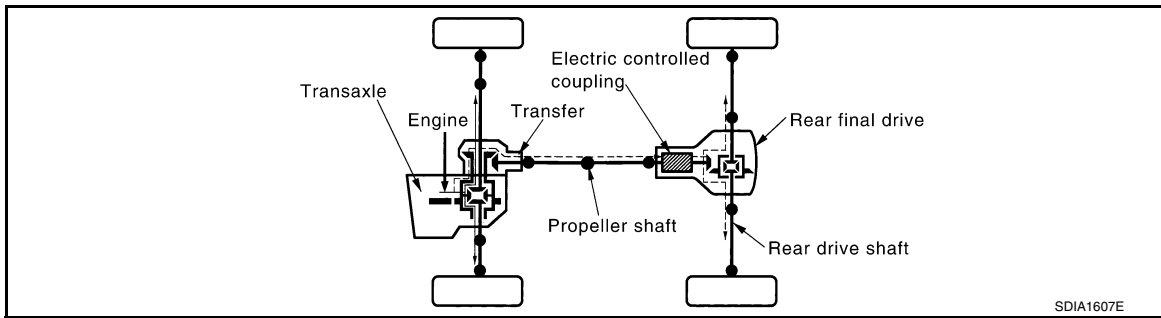

ELECTRIC CONTROLLED COUPLING

1. The AWD control unit supplies command current to electric controlled coupling (AWD solenoid).
2. The control clutch is engaged by electromagnet and torque is detected in control clutch.
3. The cam operates in response to control clutch torque and applies pressure to main clutch.
4. The main clutch transmits torque to front wheels according to pressing power.

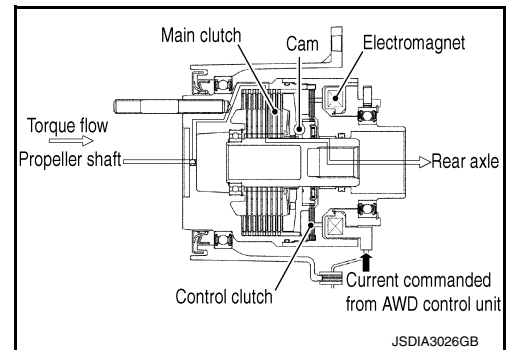

- Transmission torque to the rear wheels is determined according to command current.

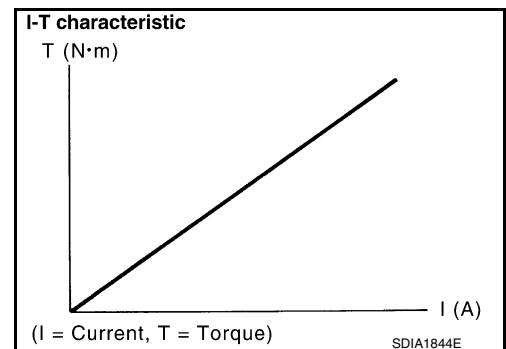

SYSTEM

AWD SYSTEM

AWD SYSTEM : System Description

INFOID:000000012892862

SYSTEM DIAGRAM

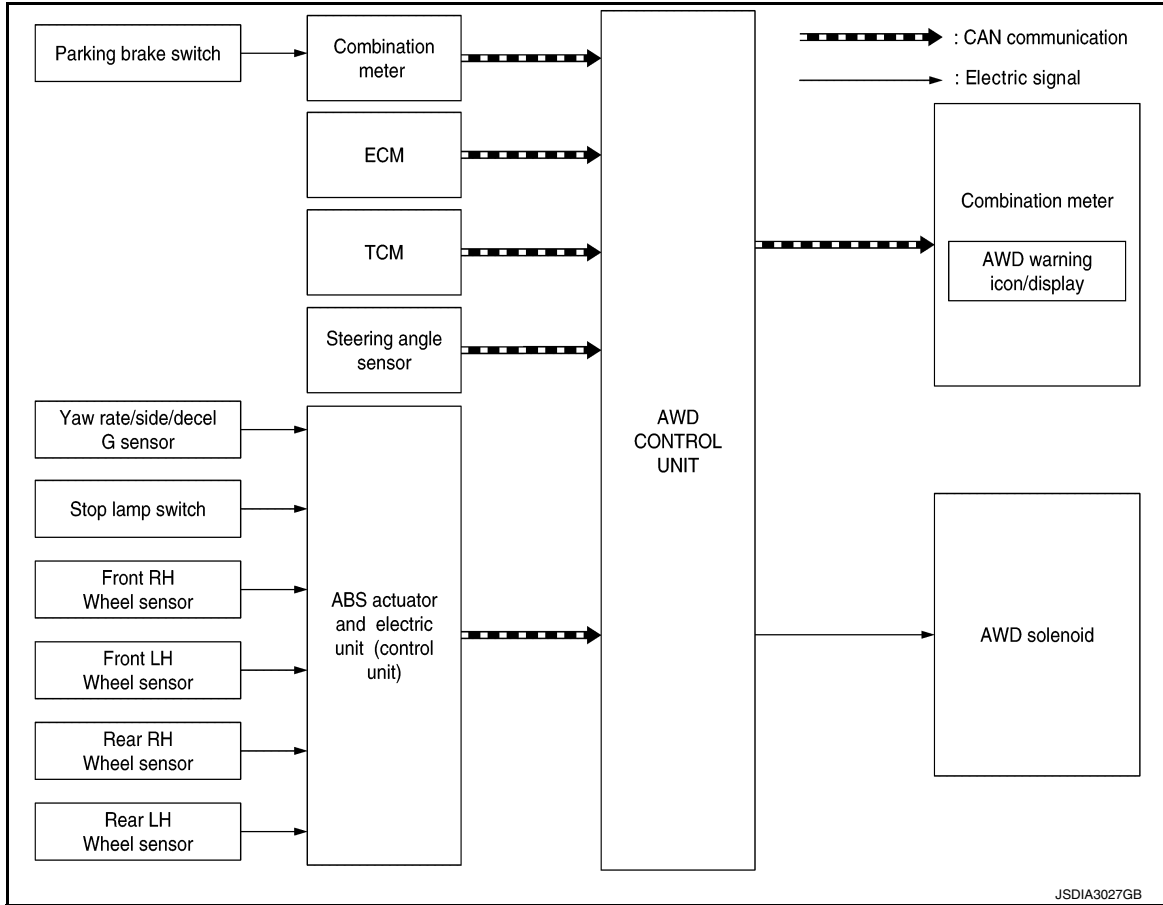

INPUT/OUTPUT SIGNAL

It transmits/receives each signal from the following AWD control unit via CAN communication line.

Component parts	Function
ABS actuator and electric unit (control unit)	Transmits the following signals via CAN communication to AWD control unit: <ul style="list-style-type: none"> • Vehicle speed signal • Stop lamp switch signal (brake signal) • Yaw rate sensor signal • Side G sensor signal • Decel G sensor signal
ECM	Transmits the following signals via CAN communication to AWD control unit: <ul style="list-style-type: none"> • Accelerator pedal position signal • Engine speed signal
TCM	Transmits the following signals via CAN communication to AWD control unit: <ul style="list-style-type: none"> • Input shaft revolutionary signal • CVT ratio signal
Combination meter	Transmits conditions of parking brake switch signal via CAN communication to AWD control unit. Receives the following signal via CAN communication from AWD control unit: <ul style="list-style-type: none"> • AWD warning icon/display signal
Steering angle sensor	Transmits conditions of steering angle sensor signal via CAN communication to AWD control unit.

A
B
C
DLN
E
F
G
H
I
J
K
L

SYSTEM

< SYSTEM DESCRIPTION >

[TRANSFER: TY21C]

DESCRIPTION

- AWD controls distribution of drive power between front-wheel drive (100:0) and 4-wheel drive (50:50) conditions according to signals from sensors.
- By receiving the steering angle sensor signal, yaw rate sensor signal, side G sensor signal and decel G sensor signal, vehicle with VDC corrects a torque distribution for front and rear wheels according to a driving operation and a behavior of the vehicle during cornering and improves drivability and safety on a slippery road surface.
- Electronic control allows optimal distribution of torque to front/rear wheels to match road conditions.
- AWD mode makes possible stable driving possible with no wheel spin, on snowy roads or other slippery surfaces.
- On roads which do not require 4-wheel drive, it contributes to improved fuel economy by driving in conditions close to front-wheel drive.
- Sensor inputs determine the vehicle's turning condition, and tight cornering/braking are controlled by distributing optimum torque to rear wheels.

NOTE:

Light tight-corner braking symptom may occur depending on driving condition. This is not malfunction.

AWD SYSTEM : Fail-Safe

INFOID:000000012892863

- If any malfunction occurs in AWD electrical system, and control unit detects the malfunction, AWD warning icon/display on information display is displayed to indicate system malfunction.
- When AWD warning icon/display is displayed, vehicle changes to front-wheel drive or shifts to 4-wheel drive (rear-wheels still have some driving torque).

DTC	AWD warning icon/display	Possible cause	Vehicle condition	
C1201	<div style="border: 1px solid black; padding: 5px; display: inline-block;">  AWD Error: See Owner's Manual </div>	Internal malfunction of AWD control unit	Front-wheel drive or shifts to 4-wheel drive (Rear-wheels still have some driving torque)	
C1203		ABS malfunction <ul style="list-style-type: none"> • Vehicle speed signal error 		
C1204		<ul style="list-style-type: none"> • Internal malfunction of electronic controlled coupling • Malfunction of AWD solenoid power supply circuit (open or short) • Malfunction of AWD solenoid command current 		
C1205		<ul style="list-style-type: none"> • Internal malfunction of AWD control unit • Malfunction of AWD solenoid power supply circuit (ground short) 		
C1210		Malfunction of engine control system		
P1804		JSDIA3103GB		Internal malfunction of AWD control unit
P181F				Writing unit characteristics is incomplete.
U1000				<ul style="list-style-type: none"> • CAN communication error • Malfunction of AWD control unit
U1010				Malfunction of AWD control unit

AWD SYSTEM : Protection Function



INFOID:000000012892864

AWD system activates its protection function (shuts down AWD system temporarily) if AWD system detects high load continuously or the front wheel tire size differs from the rear tire size. (AWD system is automatically restored if AWD system no longer detects any overload or the tire size difference is eliminated.)

SYSTEM

< SYSTEM DESCRIPTION >

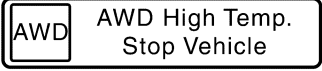
[TRANSFER: TY21C]

AWD warning icon/display	Possible cause	Vehicle condition	
<div style="border: 1px solid black; padding: 5px; display: inline-block;">  </div> <p style="text-align: right; font-size: small;">JSDIA3104GB</p> <p>(Displaying for approximately 1 minute and then turned OFF)</p>	<p>Drive train parts in protection mode. It is not malfunction. (Internal temperature rise of electronic controlled coupling) When this message is displayed, refer to DLN-53, "Description".</p>	<p>Shuts down AWD system temporarily (Front wheel drive)</p>	<p>A</p> <p>B</p> <p>C</p> <p style="background-color: black; color: white; text-align: center;">DLN</p>
<div style="border: 1px solid black; padding: 5px; display: inline-block;">  </div> <p style="text-align: right; font-size: small;">JSDIA3105GB</p> <p>(Continuing to display until ignition switch is turned OFF)</p>	<p>Malfunction in each tire or different tire diameter When this message is displayed, refer to DLN-54, "Diagnosis Procedure".</p>		<p>E</p> <p>F</p> <p>G</p>

DIAGNOSIS SYSTEM (AWD CONTROL UNIT)

< SYSTEM DESCRIPTION >

[TRANSFER: TY21C]

DIAGNOSIS SYSTEM (AWD CONTROL UNIT)

CONSULT Function

INFOID:000000012892865

CAUTION:

After disconnecting the CONSULT vehicle interface (VI) from the data link connector, the ignition must be cycled OFF → ON (for at least 5 seconds) → OFF. If this step is not performed, the BCM may not go to "sleep mode", potentially causing a discharged battery and no-start condition.

APPLICATION ITEMS

CONSULT can display each diagnostic item using the diagnostic test modes as follows.

Diagnostic test mode	Function
ECU Identification	AWD control unit part number can be read.
Self Diagnostic Result	Self-diagnostic results and freeze frame data can be read and erased quickly.*
Data Monitor	Input/Output data in the AWD control unit can be read.
Active Test	Diagnostic Test Mode in which CONSULT drives some actuators apart from the AWD control unit and also shifts some parameters in a specified range.
Work support	This mode enable a technician to adjust some devices faster and more accurately by following the indication on the CONSULT.

*: The following diagnosis information is erased by erasing.

- DTC
- Freeze frame data (FFD)

ECU IDENTIFICATION

AWD control unit part number can be read.

SELF DIAGNOSTIC RESULT

Refer to [DLN-23, "DTC Index"](#).

When "PRSNT" is displayed on self-diagnosis result.

- The system is presently malfunctioning.

When "PAST" is displayed on self-diagnosis result.

- System malfunction in the past is detected, but the system is presently normal.

FREEZE FRAME DATA (FFD)

The following vehicle status is recorded when DTC is detected and is displayed.

Freeze Frame Data Item	Description
IGN COUNTER [0 - 39]	The number of times that ignition switch is turned ON after the DTC is detected is displayed. <ul style="list-style-type: none">• When "0" is displayed: It indicates that the system is presently malfunctioning.• When except "0" is displayed: It indicates that system malfunction in the past is detected, but the system is presently normal. NOTE: Each time when ignition switch is turned OFF to ON, numerical number increases in 1→2→3...38→39. When the operation number of times exceeds 39, the number do not increase and "39" is displayed until self-diagnosis is erased.

DATA MONITOR

NOTE:

The following table includes information (items) inapplicable to this vehicle. For information (items) applicable to this vehicle, refer to CONSULT display items.

Monitor item (Unit)	Remarks
STOP LAMP SW [On/Off]	Stop lamp switch signal status via CAN communication line is displayed.
ENG SPEED SIG [Run/Stop]	Engine status is displayed.
ETS ACTUATOR [On/Off]	Operating condition of AWD actuator relay (integrated in AWD control unit) is displayed.

DIAGNOSIS SYSTEM (AWD CONTROL UNIT)

< SYSTEM DESCRIPTION >

[TRANSFER: TY21C]

Monitor item (Unit)	Remarks
4WD WARN LAMP [On/Off]	Control status of AWD warning icon/display is displayed.
4WD MODE SW [AUTO/LOCK]	Mode switch is not equipped, but displayed.
4WD MODE MON [AUTO/LOCK]	Control status of AWD is displayed.
DIS-TIRE MONI [mm]	Improper size tire installed condition is displayed.
P BRAKE SW [On/Off]	Parking switch signal status via CAN communication line is displayed.
BATTERY VOLT [V]	Power supply voltage for AWD control unit
THRTL POS SEN [%]	Throttle opening status is displayed.
ETS SOLENOID [A]	Monitored value of current at AWD solenoid
FR RH SENSOR [km/h] or [mph]	Wheel speed calculated by front RH wheel sensor signal is displayed.
FR LH SENSOR [km/h] or [mph]	Wheel speed calculated by front LH wheel sensor signal is displayed.
RR RH SENSOR [km/h] or [mph]	Wheel speed calculated by rear RH wheel sensor signal is displayed.
RR LH SENSOR [km/h] or [mph]	Wheel speed calculated by rear LH wheel sensor signal is displayed.

ACTIVE TEST

Use this mode to determine and identify the details of a malfunction based on self-diagnostic results or data monitor. AWD control unit gives drive signal to actuator with receiving command from CONSULT to check operation of actuator.

Test item	Condition	Description
ETS S/V (Detects AWD solenoid)	<ul style="list-style-type: none"> Vehicle stopped Engine running No DTC detected 	Change command current value to AWD solenoid, and then change driving mode. (Monitor value is normal if it is within approx. $\pm 10\%$ of command value.) <ul style="list-style-type: none"> Qu: Increase current value in increments of 0.2 A Qd: Decrease current value in increments of 0.2 A UP: Increase current value in increments of 0.02 A DOWN: Decrease current value in increments of 0.02 A

CAUTION:

Never energize continuously for a long time.

WORK SUPPORT

Item	Usage
UNIT CHARACTERISTICS DATA	Display the unit characteristics of electric controlled coupling written to AWD control unit.
UNIT CHARACTERISTICS WRITE	Writes the unit characteristics of electric controlled coupling to AWD control unit.

AWD CONTROL UNIT

< ECU DIAGNOSIS INFORMATION >

[TRANSFER: TY21C]

ECU DIAGNOSIS INFORMATION

AWD CONTROL UNIT

Reference Value

INFOID:0000000012892866

VALUES ON THE DIAGNOSIS TOOL

NOTE:

The following table includes information (items) inapplicable to this vehicle. For information (items) applicable to this vehicle, refer to CONSULT display items.

Monitor item	Condition	Value/Status
STOP LAMP SW	Brake pedal: Depressed	On
	Brake pedal: Released	Off
ENG SPEED SIG	Engine stopped (Engine speed: Less than 400 rpm)	Stop
	Engine running (Engine speed: 400 rpm or more)	Run
ETS ACTUATOR	Engine stopped (Ignition switch: ON)	Off
	Engine running	On
4WD WARN LAMP	AWD warning icon/display: ON	On
	AWD warning icon/display: OFF	Off
4WD MODE SW	Always	AUTO
4WD MODE MON	Always	AUTO
DIS-TIRE MONI	Vehicle running with normal size tire installed	0 – 4 mm
	Vehicle running with improper size tire installed (Front/rear tire size difference, wear condition)	4 – 8 mm, 8 – mm
P BRAKE SW	Parking brake operated	On
	Parking brake not operated	Off
BATTERY VOLT	Always	Battery voltage
THRTL POS SEN	When depressing accelerator pedal (Value rises gradually in response to throttle position.)	0 – 100%
ETS SOLENOID	Engine running • At idle speed	Approx. 0.000 A
	Engine running • 3,000 rpm or more constant	Approx. 0.000 – 1.800 A*
FR RH SENSOR	Vehicle stopped	0.00 km/h (0.00 mph)
	Vehicle running CAUTION: Check air pressure of tire under standard condition.	Nearly matches the speed meter display (±10% or less)
FR LH SENSOR	Vehicle stopped	0.00 km/h (0.00 mph)
	Vehicle running CAUTION: Check air pressure of tire under standard condition.	Nearly matches the speed meter display (±10% or less)
RR RH SENSOR	Vehicle stopped	0.00 km/h (0.00 mph)
	Vehicle running CAUTION: Check air pressure of tire under standard condition.	Nearly matches the speed meter display (±10% or less)
RR LH SENSOR	Vehicle stopped	0.00 km/h (0.00 mph)
	Vehicle running CAUTION: Check air pressure of tire under standard condition.	Nearly matches the speed meter display (±10%)

AWD CONTROL UNIT

< ECU DIAGNOSIS INFORMATION >

[TRANSFER: TY21C]

*: The values are changed by throttle opening and engine speed.

TERMINAL LAYOUT

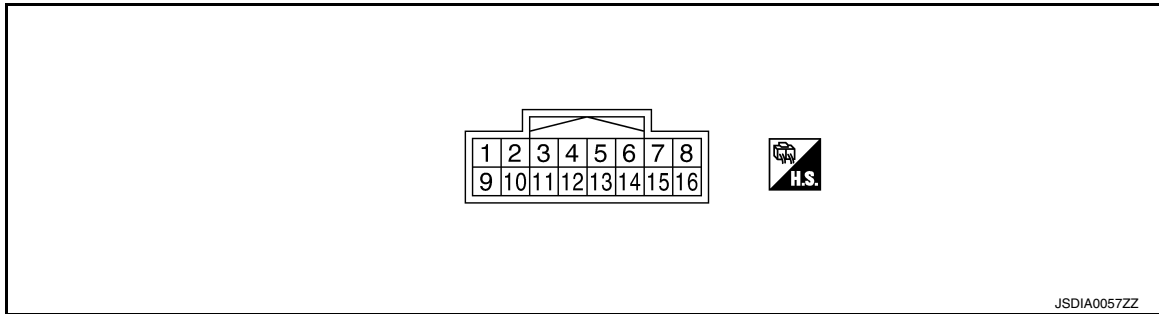

PHYSICAL VALUES

Terminal No. (Wire color)		Description		Condition	Value (Approx.)
+	-	Signal name	Input/ Output		
1 (G/W)	Ground	AWD solenoid power supply	Output	Engine speed: At idle	0 V
				Engine speed: 3,000 rpm or more constant	2.5 V*
2 (Y)	Ground	AWD solenoid ground	Input	Always	0 V
7 (W/O)	Ground	Ignition switch	Input	Ignition switch: ON	Battery voltage
				Ignition switch: OFF	0 V
8 (L)	—	CAN-H	Input/ Output	—	—
9 (L/W)	Ground	Power supply (AWD solenoid)	Input	Always	Battery voltage
10 (GR)	Ground	Ground	—	Always	0 V
11 (GR)	Ground	Ground	—	Always	0 V
15 (G)	Ground	Power supply (AWD control unit)	Input	Always	Battery voltage
16 (P)	—	CAN-L	Input/ Output	—	—

*: The values are changed by throttle opening and engine speed.

CAUTION:

When using circuit tester to measure voltage for inspection, be sure not to extend forcibly any connector terminals.

Fail-Safe

INFOID:000000012892867

- If any malfunction occurs in AWD electrical system, and control unit detects the malfunction, AWD warning icon/display on information display is displayed to indicate system malfunction.
- When AWD warning icon/display is displayed, vehicle changes to front-wheel drive or shifts to 4-wheel drive (rear-wheels still have some driving torque).

AWD CONTROL UNIT

< ECU DIAGNOSIS INFORMATION >

[TRANSFER: TY21C]

DTC	AWD warning icon/display	Possible cause	Vehicle condition	
C1201	<div style="border: 1px solid black; padding: 5px; display: inline-block;"> AWD Error: See Owner's Manual </div>	Internal malfunction of AWD control unit	Front-wheel drive or shifts to 4-wheel drive (Rear-wheels still have some driving torque)	
C1203		ABS malfunction • Vehicle speed signal error		
C1204		• Internal malfunction of electronic controlled coupling • Malfunction of AWD solenoid power supply circuit (open or short) • Malfunction of AWD solenoid command current		
C1205		• Internal malfunction of AWD control unit • Malfunction of AWD solenoid power supply circuit (ground short)		
C1210		Malfunction of engine control system		
P1804		JSDIA3103GB		Internal malfunction of AWD control unit
P181F				Writing unit characteristics is incomplete.
U1000				• CAN communication error • Malfunction of AWD control unit
U1010				Malfunction of AWD control unit

Protection Function

INFOID:000000012892868

AWD system activates its protection function (shuts down AWD system temporarily) if AWD system detects high load continuously or the front wheel tire size differs from the rear tire size. (AWD system is automatically restored if AWD system no longer detects any overload or the tire size difference is eliminated.)

AWD warning icon/display	Possible cause	Vehicle condition
<div style="border: 1px solid black; padding: 5px; display: inline-block;"> AWD High Temp. Stop Vehicle </div> <p style="font-size: x-small; margin-top: 5px;">JSDIA3104GB (Displaying for approximately 1 minute and then turned OFF)</p>	Drive train parts in protection mode. It is not malfunction. (Internal temperature rise of electronic controlled coupling) When this message is displayed, refer to DLN-53, "Description" .	Shuts down AWD system temporarily (Front wheel drive)
<div style="border: 1px solid black; padding: 5px; display: inline-block;"> AWD Tire Size Incorrect: See Owner's Manual </div> <p style="font-size: x-small; margin-top: 5px;">JSDIA3105GB (Continuing to display until ignition switch is turned OFF)</p>	Malfunction in each tire or different tire diameter When this message is displayed, refer to DLN-54, "Diagnosis Procedure" .	

DTC Inspection Priority Chart

INFOID:000000012892869

If some DTCs are displayed at the same time, perform inspections one by one based on the following priority chart.

Priority	Detected items (DTC)
1	<ul style="list-style-type: none"> • U1000 CAN COMM CIRCUIT • U1010 CONTROL UNIT (CAN)
2	<ul style="list-style-type: none"> • C1201 CONTROLLER FAILURE • C1205 4WD ACTUATOR RLY

AWD CONTROL UNIT

< ECU DIAGNOSIS INFORMATION >

[TRANSFER: TY21C]

Priority	Detected items (DTC)
3	• C1204 4WD SOLENOID
4	• C1203 ABS SYSTEM • C1210 ENGINE SIGNAL 1
5	• P1804 CONTROL UNIT 3
6	• P181F INCOMP CALIBRATION

DTC Index

INFOID:000000012892870

DTC	Display Item	Reference
C1201	CONTROLLER FAILURE	DLN-34, "DTC Description"
C1203	ABS SYSTEM	DLN-35, "DTC Description"
C1204	4WD SOLENOID	DLN-36, "DTC Description"
C1205	4WD ACTUATOR RLY	DLN-39, "DTC Description"
C1210	ENGINE SIGNAL 1	DLN-41, "DTC Description"
P1804	CONTROL UNIT 3	DLN-42, "DTC Description"
P181F	INCOMP CALIBRATION	DLN-43, "DTC Description"
U1000	CAN COMM CIRCUIT	DLN-44, "DTC Description"
U1010	CONTROL UNIT (CAN)	DLN-45, "DTC Description"

A
B
C
DLN
E
F
G
H
I
J
K
L
M
N
O
P

< WIRING DIAGRAM >

WIRING DIAGRAM

AWD SYSTEM

Wiring Diagram

INFOID:0000000012892871

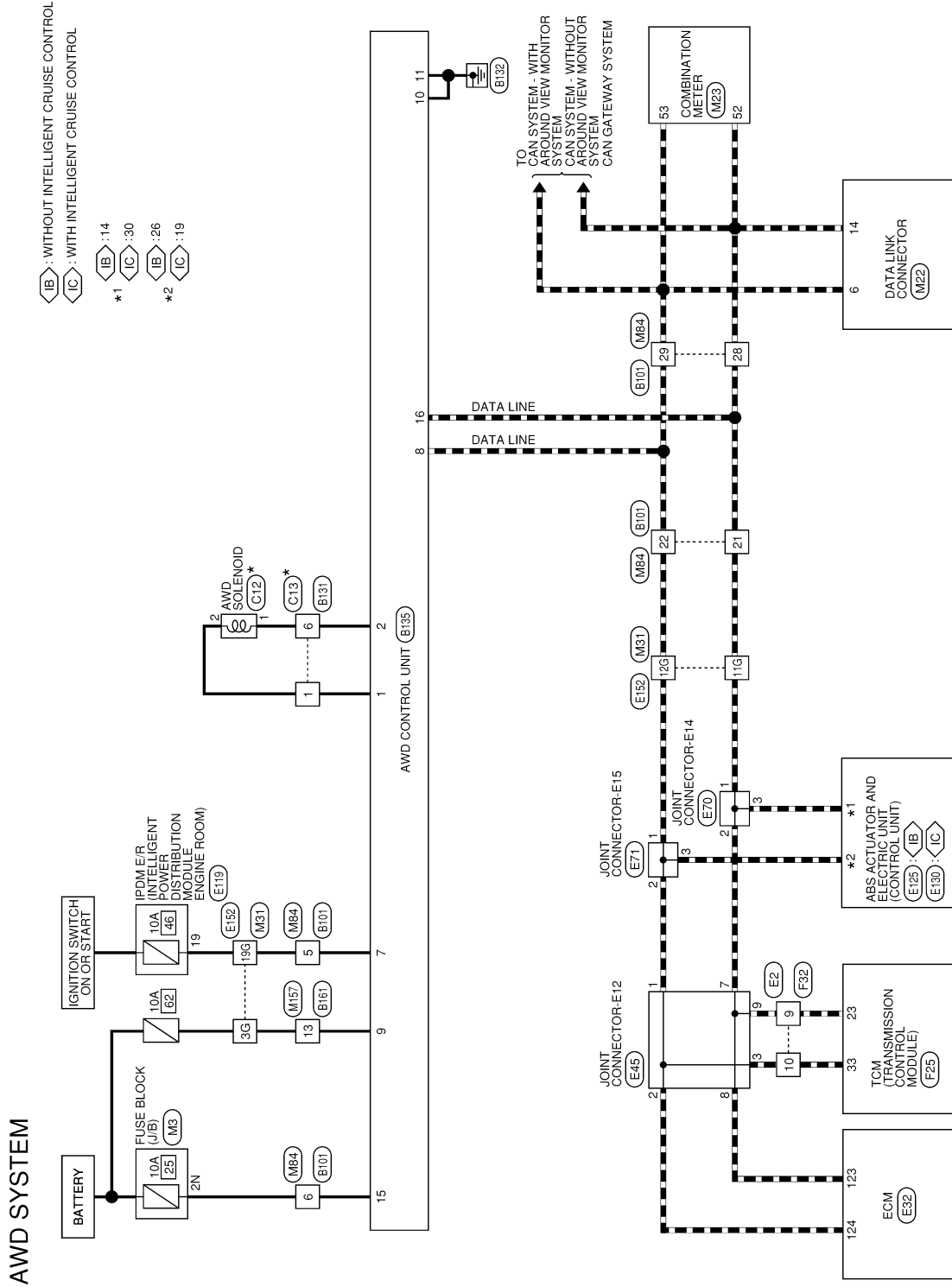

AWD SYSTEM CONNECTORS

Connector No.	M3
Connector Name	FUSE BLOCK (J/B)
Connector Type	CS06FW-M2
Connector Color	WHITE

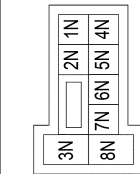

Terminal No.	2N	Color of Wire	BG	Signal Name	-
--------------	----	---------------	----	-------------	---

Connector No.	M22
Connector Name	DATA LINK CONNECTOR
Connector Type	BD16FW
Connector Color	WHITE

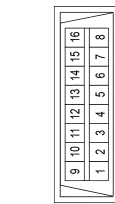

Terminal No.	6	Color of Wire	L	Signal Name	-
	14		P		-

Connector No.	M23
Connector Name	COMBINATION METER
Connector Type	TH16FW-NH
Connector Color	WHITE

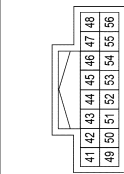

Terminal No.	52	Color of Wire	P	Signal Name	CAN-L
--------------	----	---------------	---	-------------	-------

53	L	CAN-H
Connector No.	M31	WIRE TO WIRE
Connector Name	TH80FW-CS16-TM4	WHITE
Connector Type		
Connector Color		

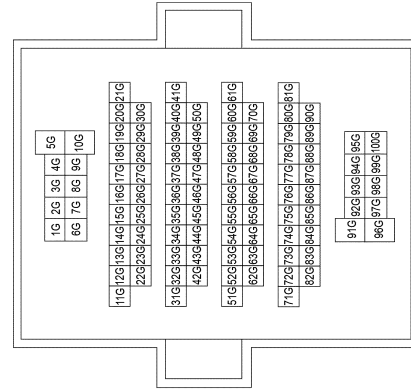

Terminal No.	3G	Color of Wire	SB	Signal Name	-
	11G		P		-
	12G		L		-
	19G		W		-

Connector No.	M84	WIRE TO WIRE
Connector Name	TH32FW-NH	WHITE
Connector Type		
Connector Color		

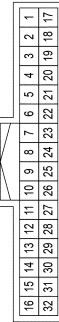

Terminal No.	5	Color of Wire	W	Signal Name	-
	6		BG		-
	21		P		-

22	L	-
28	P	-
29	L	-

Connector No.	M157	WIRE TO WIRE
Connector Name	NS16FW-CS	WHITE
Connector Type		
Connector Color		

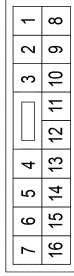

Terminal No.	13	Color of Wire	SB	Signal Name	-
--------------	----	---------------	----	-------------	---

Connector No.	E2	WIRE TO WIRE
Connector Name	TH16MW-NH	WHITE
Connector Type		
Connector Color		



Terminal No.	9	Color of Wire	P	Signal Name	-
	10		L		-

A
B
C
DLN
E
F
G
H
I
J
K
L
M
N
O
P

AWD SYSTEM

< WIRING DIAGRAM >

[TRANSFER: TY21C]

Connector No.	19	SB	SUB ECU
Connector Name	E125		
Connector Type	ABS ACTUATOR AND ELECTRIC UNIT (CONTROL UNIT) (WITHOUT INTELLIGENT CRUISE CONTROL)		
Connector Color	BEZ34FB-BHY2-BJZ2-LH		
Color of Wire	BLACK		

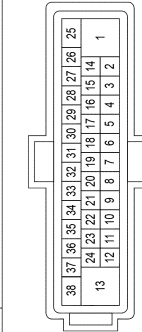

Terminal No.	14	P	CAN-L
Terminal No.	26	L	CAN-H

Connector No.	E130
Connector Name	ABS ACTUATOR AND ELECTRIC UNIT (CONTROL UNIT) (WITH INTELLIGENT CRUISE CONTROL)
Connector Type	SAZ34FB-HS2-SJZ2-UH
Connector Color	BLACK

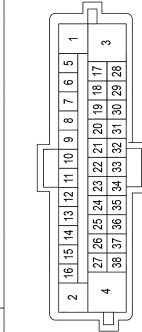

Terminal No.	19	L	CAN-H
Terminal No.	30	P	CAN-L

Connector No.	E70
Connector Name	JOINT CONNECTOR-E14
Connector Type	RH06FB
Connector Color	BLACK

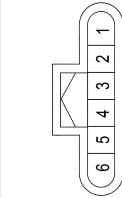

Terminal No.	1	P	-
Terminal No.	2	P	-
Terminal No.	3	P	-

Connector No.	E71
Connector Name	JOINT CONNECTOR-E15
Connector Type	RH06FB
Connector Color	BLACK

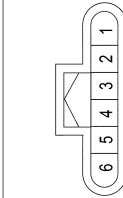

Terminal No.	1	L	-
Terminal No.	2	L	-
Terminal No.	3	L	-

Connector No.	E119
Connector Name	IPDM E/R (INTELLIGENT POWER DISTRIBUTION MODULE ENGINE ROOM)
Connector Type	TH32FW-NH
Connector Color	WHITE

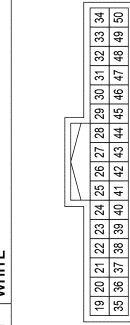

Terminal No.	-	-	-
Color of Wire	-	-	-
Signal Name	-	-	-

Connector No.	E32
Connector Name	ECM
Connector Type	RH24FB-RZ8-L-LH
Connector Color	BLACK

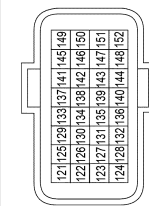

Terminal No.	123	P	CAN-L
Terminal No.	124	L	CAN-H

Connector No.	E45
Connector Name	JOINT CONNECTOR-E12
Connector Type	A12FL
Connector Color	BLUE

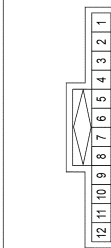

Terminal No.	1	L	-
Terminal No.	2	L	-
Terminal No.	3	L	-
Terminal No.	7	P	-
Terminal No.	8	P	-
Terminal No.	9	P	-

AADIA0994GB

AWD SYSTEM

< WIRING DIAGRAM >

[TRANSFER: TY21C]

Connector No.	B101
Connector Name	WIRE TO WIRE
Connector Type	TH32MW-NH
Connector Color	WHITE

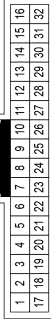

Terminal No.	Color of Wire	Signal Name
5	W/O	-
6	G	-
21	P	-
22	L	-
28	P	-
29	L	-

Connector No.	B131
Connector Name	WIRE TO WIRE
Connector Type	RH12FB
Connector Color	BLACK

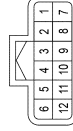

Terminal No.	Color of Wire	Signal Name
1	G/W	-
6	Y	-

Connector No.	F32
Connector Name	WIRE TO WIRE
Connector Type	TH16FW-NH
Connector Color	WHITE

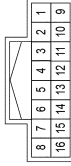

Terminal No.	Color of Wire	Signal Name
9	P	-
10	L	-

Connector No.	C12
Connector Name	AWD SOLENOID
Connector Type	RS02FGY
Connector Color	GRAY



Terminal No.	Color of Wire	Signal Name
1	Y	-
2	SB	-

Connector No.	C13
Connector Name	WIRE TO WIRE
Connector Type	RH12MB
Connector Color	BLACK

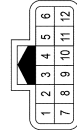

Terminal No.	Color of Wire	Signal Name
1	SB	-
6	Y	-

Connector No.	E152
Connector Name	WIRE TO WIRE
Connector Type	TH80MW-CS16-TM4
Connector Color	WHITE

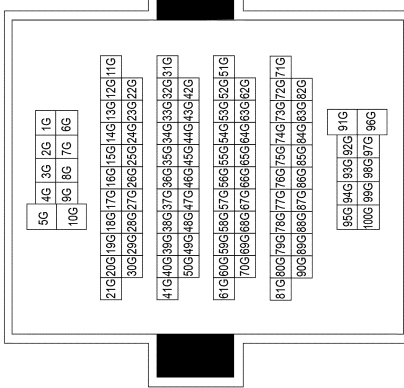

Terminal No.	Color of Wire	Signal Name
3G	LG	-
11G	P	-
12G	L	-
19G	SB	-

Connector No.	F25
Connector Name	TCM (TRANSMISSION CONTROL MODULE)
Connector Type	RH40FB-RZ8-L-RH
Connector Color	BLACK

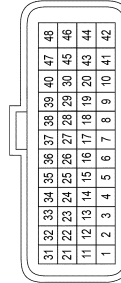

Terminal No.	Color of Wire	Signal Name
23	P	CAN-L
L	L	CAN-H

AADIA0995GB

A
B
C
DLN
E
F
G
H
I
J
K
L
M
N
O
P

AWD SYSTEM

< WIRING DIAGRAM >

[TRANSFER: TY21C]

Connector No.	B135
Connector Name	AWD CONTROL UNIT
Connector Type	TH16FW-NH
Connector Color	WHITE

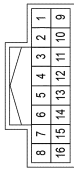

Terminal No.	Color of Wire	Signal Name
1	G/W	4WD SOL(+)
2	Y	4WD SOL(-)
3	-	-
4	-	-
5	-	-
6	-	-
7	W/O	IGN
8	L	CAN-H
9	L/W	4WD SOL BATT
10	GR	GND
11	GR	GND
12	-	-
13	-	-
14	-	-
15	G	BATT
16	P	CAN-L

Connector No.	B161
Connector Name	WIRE TO WIRE
Connector Type	NS16MW-CS
Connector Color	WHITE

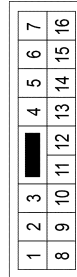

Terminal No.	Color of Wire	Signal Name
13	L/W	-

AADIA0996GB

BASIC INSPECTION

DIAGNOSIS AND REPAIR WORK FLOW

Work Flow

INFOID:000000012892872

DETAILED FLOW

1. INTERVIEW FROM THE CUSTOMER

Clarify customer complaints before inspection. First of all, perform an interview utilizing [DLN-30, "Diagnostic Work Sheet"](#) and reproduce symptoms as well as fully understand it. Ask customer about his/her complaints carefully. Check symptoms by driving vehicle with customer, if necessary.

CAUTION:

Customers are not professional. Never guess easily like "maybe the customer means that..." or "maybe the customer mentions this symptom".

>> GO TO 2.

2. CHECK SYMPTOM

Reproduce the symptom that is indicated by the customer, based on the information from the customer obtained by interview. Also check that the symptom is not caused by protection function. Refer to [DLN-22, "Protection Function"](#).

CAUTION:

When the symptom is caused by normal operation, fully inspect each portion and obtain the understanding of customer that the symptom is not caused by a malfunction.

>> GO TO 3.

3. PERFORM SELF-DIAGNOSIS

 **CONSULT**

Select "Self Diagnostic Result" mode of "ALL MODE AWD/4WD".

Is any DTC detected?

- YES >> Record or print self-diagnosis results. GO TO 4.
- NO >> GO TO 6.

4. RECHECK SYMPTOM

 **CONSULT**

1. Erase "Self Diagnostic Result" mode of "ALL MODE AWD/4WD".
2. Perform DTC confirmation procedures for the error detected system.

NOTE:

If some DTCs are detected at the same time, determine the order for performing the diagnosis based on [LAN-21, "Trouble Diagnosis Flow Chart"](#).

Is any DTC detected?

- YES >> GO TO 5.
- NO >> Check harness and connectors based on the information obtained by interview. Refer to [GI-42, "Intermittent Incident"](#).

5. REPAIR OR REPLACE ERROR-DETECTED PARTS

- Repair or replace error-detected parts.
- Reconnect part or connector after repairing or replacing.
- When DTC is detected, erase "Self Diagnostic Result" mode of "ALL MODE AWD/4WD".

>> GO TO 7.

6. IDENTIFY ERROR-DETECTED SYSTEM BY SYMPTOM DIAGNOSIS

Estimate error-detected system based on symptom diagnosis and perform inspection.

Can the error-detected system be identified?

A
B
C
DLN
E
F
G
H
I
J
K
L
M
N
O
P

DIAGNOSIS AND REPAIR WORK FLOW

< BASIC INSPECTION >

[TRANSFER: TY21C]

YES >> GO TO 7.

NO >> Check harness and connectors based on the information obtained by interview. Refer to [GI-42](#), "[Intermittent Incident](#)".

7. FINAL CHECK

CONSULT

1. Check the reference value for AWD control unit.
2. Recheck the symptom and check that symptom is not reproduced on the same conditions.

Is the symptom reproduced?

YES >> GO TO 3.

NO >> Inspection End.

Diagnostic Work Sheet

INFOID:000000012892873

Description

- In general, customers have their own criteria for a problem. Therefore, it is important to understand the symptom and status well enough by asking the customer about his/her concerns carefully. To systemize all the information for the diagnosis, prepare the interview sheet referring to the interview points.
- In some cases, multiple conditions that appear simultaneously may cause a DTC to be detected.

Interview sheet sample

Interview sheet								
Customer name		MR/MS	Registration number		Initial year registration			
			Vehicle type		VIN			
Storage date			Engine		Mileage km (Mile)			
Symptom			<input type="checkbox"/> Vehicle does not enter AWD mode.					
			<input type="checkbox"/> AWD warning icon/display is displayed.					
			<input type="checkbox"/> Heavy tight-corner braking symptom occurs					
			<input type="checkbox"/> Noise <input type="checkbox"/> Vibration					
			<input type="checkbox"/> Others (_____)					
First occurrence			<input type="checkbox"/> Recently <input type="checkbox"/> Others (_____)					
Frequency of occurrence			<input type="checkbox"/> Always <input type="checkbox"/> Under a certain conditions of _____ <input type="checkbox"/> Sometimes (time(s)/day)					
Climate conditions			<input type="checkbox"/> Irrelevant					
			Weather			<input type="checkbox"/> Fine <input type="checkbox"/> Cloud <input type="checkbox"/> Rain <input type="checkbox"/> Snow <input type="checkbox"/> Others (_____)		
			Temperature			<input type="checkbox"/> Hot <input type="checkbox"/> Warm <input type="checkbox"/> Cool <input type="checkbox"/> Cold <input type="checkbox"/> Temperature (Approx. _____ °C)		
Relative humidity			<input type="checkbox"/> High <input type="checkbox"/> Moderate <input type="checkbox"/> Low					
Road conditions			<input type="checkbox"/> Urban area <input type="checkbox"/> Suburb area <input type="checkbox"/> High way <input type="checkbox"/> Mounting road (uphill or down hill) <input type="checkbox"/> Rough road					
Operation conditions, etc.			<input type="checkbox"/> Irrelevant <input type="checkbox"/> When engine starts <input type="checkbox"/> During idling <input type="checkbox"/> During driving <input type="checkbox"/> During acceleration <input type="checkbox"/> At constant speed driving <input type="checkbox"/> During deceleration <input type="checkbox"/> During cornering (right curve or left curve)					

DIAGNOSIS AND REPAIR WORK FLOW

< BASIC INSPECTION >

[TRANSFER: TY21C]

Interview sheet

Customer name	MR/MS	Registration number		Initial year registration	
		Vehicle type		VIN	
Storage date		Engine		Mileage	km (Mile)
Other conditions					

Memo

A
B
C

DLN

E
F
G
H
I
J
K
L
M
N
O
P

ADDITIONAL SERVICE WHEN REPLACING AWD CONTROL UNIT

< BASIC INSPECTION >

[TRANSFER: TY21C]

ADDITIONAL SERVICE WHEN REPLACING AWD CONTROL UNIT

Description

INFOID:000000012892874

When replacing AWD control unit, unit characteristics writing is required.

Work Procedure

INFOID:000000012892875

1. PERFORM WRITING UNIT CHARACTERISTICS

Perform writing unit characteristics of electric controlled coupling.

>> Refer to [DLN-33. "Work Procedure"](#).

UNIT CHARACTERISTICS WRITING

Description

INFOID:000000012892876

When replacing AWD control unit, rear final drive assembly and/or electric controlled coupling, unit characteristics of electric controlled coupling writing is required. Refer to [DLN-33, "Work Procedure"](#).

Work Procedure

INFOID:000000012892877

1. UNIT CHARACTERISTICS WRITING

CONSULT

1. Confirm the unit characteristics of electric controlled coupling.
NOTE:
Unit characteristics is 12-digit alphanumeric.
2. Turn the ignition switch OFF to ON.
3. Select "UNIT CHARACTERISTICS WRITE" in "Work support" for "ALL MODE AWD/4WD".
4. Input unit characteristics.
5. Select "Start".
6. Check that "UNIT CHARACTERISTICS WRITE COMPLETED" is displayed.

>> Work End.

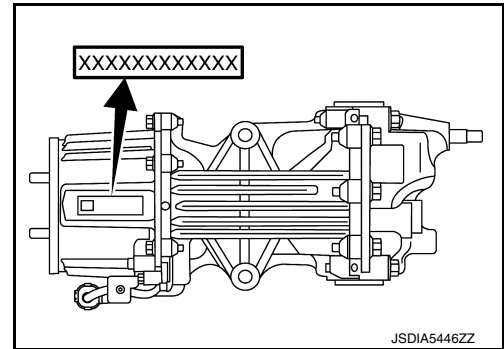

A
B
C
DLN
E
F
G
H
I
J
K
L
M
N
O
P

DTC/CIRCUIT DIAGNOSIS

C1201 AWD CONTROL UNIT

DTC Description

INFOID:0000000012892878

DTC DETECTION LOGIC

Malfunction has occurred inside AWD control unit.

DTC No.	CONSULT screen terms (Trouble diagnosis content)	DTC detecting condition	
		Diagnosis condition	Ignition switch: ON
C1201	CONTROLLER FAILURE (Control unit failure)	Signal	—
		Threshold	—
		Diagnosis delay time	—

POSSIBLE CAUSE

Internal malfunction of AWD control unit

FAIL-SAFE

Front-wheel drive or shifts to 4-wheel drive (rear-wheels still have some driving torque).

DTC CONFIRMATION PROCEDURE

1. PRECONDITIONING

If “DTC CONFIRMATION PROCEDURE” has been previously conducted, always turn ignition switch OFF and wait at least 10 seconds before conducting the next test.

>> GO TO 2.

2. DTC REPRODUCTION PROCEDURE

CONSULT

1. Turn the ignition switch OFF to ON.
2. Select “Self Diagnostic Result” for “ALL MODE AWD/4WD”.

Is DTC “C1201” detected?

- YES >> Proceed to [DLN-34, "Diagnosis Procedure"](#).
- NO-1 >> To check malfunction symptom before repair: Refer to [GI-42, "Intermittent Incident"](#).
- NO-2 >> Confirmation after repair: Inspection End.

Diagnosis Procedure

INFOID:0000000012892879

1. PERFORM SELF-DIAGNOSIS

CONSULT

1. Erase self-diagnostic results for “ALL MODE AWD/4WD”.
2. Turn the ignition switch OFF, and then wait 10 seconds or more.
3. Select “Self Diagnostic Result” mode of “ALL MODE AWD/4WD”.

Is DTC “C1201” detected?

- YES >> Replace AWD control unit. Refer to [DLN-58, "Removal and Installation"](#).
- NO >> Check AWD control unit pin terminals for damage or loose connection with harness connector. If any items are damaged, repair or replace error-detected parts.

C1203 ABS ACTUATOR AND ELECTRIC UNIT (CONTROL UNIT)

< DTC/CIRCUIT DIAGNOSIS >

[TRANSFER: TY21C]

C1203 ABS ACTUATOR AND ELECTRIC UNIT (CONTROL UNIT)

DTC Description

INFOID:000000012892880

DTC DETECTION LOGIC

Malfunction related to wheel sensor has been detected by ABS actuator and electric unit (control unit).

DTC No.	CONSULT screen terms (Trouble diagnosis content)	DTC detecting condition	
C1203	ABS SYSTEM (ABS system)	Diagnosis condition	Engine running and vehicle running
		Signal	Vehicle speed signal
		Threshold	—
		Diagnosis delay time	—

POSSIBLE CAUSE

ABS malfunction

- Vehicle speed signal error

FAIL-SAFE

Front-wheel drive or shifts to 4-wheel drive (rear-wheels still have some driving torque).

DTC CONFIRMATION PROCEDURE

1. PRECONDITIONING

If "DTC CONFIRMATION PROCEDURE" has been previously conducted, always turn ignition switch OFF and wait at least 10 seconds before conducting the next test.

>> GO TO 2.

2. DTC REPRODUCTION PROCEDURE

CONSULT

1. Start the engine and drive at 30 km/h (19 MPH) or more for approximately 1 minute.
2. Select "Self Diagnostic Result" mode of "ALL MODE AWD/4WD".

Is DTC "C1203" detected?

- YES >> Proceed to [DLN-35, "Diagnosis Procedure"](#).
- NO-1 >> To check malfunction symptom before repair: Refer to [GI-42, "Intermittent Incident"](#).
- NO-2 >> Confirmation after repair: Inspection End.

Diagnosis Procedure

INFOID:000000012892881

1. PERFORM ABS ACTUATOR AND ELECTRIC UNIT (CONTROL UNIT) SELF-DIAGNOSIS

CONSULT

Perform "Self Diagnostic Result" mode of "ABS".

Is any DTC detected?

- YES >> Check the DTC. Refer to [TM-58, "DTC Index"](#).
- NO >> GO TO 2.

2. CHECK TERMINALS AND HARNESS CONNECTORS

Check AWD control unit pin terminals for damage or loose connection with harness connector.

Is inspection result normal?

- YES >> After turning the ignition switch OFF, perform DTC confirmation procedure again. If DTC "C1203" is detected, Replace AWD control unit. Refer to [DLN-58, "Removal and Installation"](#).
- NO >> Repair or replace error-detected parts.

C1204 AWD SOLENOID

< DTC/CIRCUIT DIAGNOSIS >

[TRANSFER: TY21C]

C1204 AWD SOLENOID

DTC Description

INFOID:000000012892882

DTC DETECTION LOGIC

Malfunction related to AWD solenoid has been detected.

DTC No.	CONSULT screen terms (Trouble diagnosis content)	DTC detecting condition	
		Diagnosis condition	Ignition switch: ON
C1204	4WD SOLENOID (4WD solenoid)	Signal	—
		Threshold	—
		Diagnosis delay time	—

POSSIBLE CAUSE

- Internal malfunction of electronic controlled coupling
- Malfunction of AWD solenoid power supply circuit (open or short)
- Malfunction of AWD solenoid command current

FAIL-SAFE

Front-wheel drive or shifts to 4-wheel drive (rear-wheels still have some driving torque).

DTC CONFIRMATION PROCEDURE

1. PRECONDITIONING

If "DTC CONFIRMATION PROCEDURE" has been previously conducted, always turn ignition switch OFF and wait at least 10 seconds before conducting the next test.

>> GO TO 2.

2. DTC REPRODUCTION PROCEDURE

Ⓟ CONSULT

1. Turn the ignition switch OFF to ON.
2. Perform "Self Diagnostic Result" mode of "ALL MODE AWD/4WD".

Is DTC "C1204" detected?

- YES >> Proceed to [DLN-36. "Diagnosis Procedure"](#).
- NO-1 >> To check malfunction symptom before repair: Refer to [GI-42. "Intermittent Incident"](#).
- NO-2 >> Confirmation after repair: Inspection End.

Diagnosis Procedure

INFOID:000000012892883

1. CHECK AWD SOLENOID POWER SUPPLY (1)

1. Turn the ignition switch OFF.
2. Disconnect AWD control unit harness connector.
3. Check the voltage between AWD control unit harness connector and ground.

AWD control unit		—	Voltage
Connector	Terminal		
B135	9	Ground	Battery voltage

4. Turn the ignition switch ON.
CAUTION:
Never start the engine.
5. Check the voltage between AWD control unit harness connector and ground.

C1204 AWD SOLENOID

< DTC/CIRCUIT DIAGNOSIS >

[TRANSFER: TY21C]

AWD control unit		—	Voltage
Connector	Terminal		
B135	9	Ground	Battery voltage

Is the inspection result normal?

- YES >> GO TO 3.
- NO >> GO TO 2.

2.CHECK AWD SOLENOID POWER SUPPLY (2)

1. Turn the ignition switch OFF.
2. Check the 10A fuse (#62)
3. Check the harness for open or short between AWD control unit harness connector No.9 terminal and 10A fuse (#62).

Is the inspection result normal?

- YES >> Perform the trouble diagnosis for power supply circuit. Refer to [PG-16, "Wiring Diagram - BATTERY POWER SUPPLY -"](#).
- NO >> Repair or replace error-detected parts.

3.CHECK AWD SOLENOID GROUND

Check the continuity between AWD control unit harness connector and ground.

AWD control unit		—	Continuity
Connector	Terminal		
B135	10	Ground	Yes
	11		

Is the inspection result normal?

- YES >> GO TO 4.
- NO >> Repair or replace error-detected parts.

4.CHECK AWD SOLENOID CIRCUIT (1)

Check the resistance between AWD control unit harness connector.

AWD control unit			Resistance (Approx.)
Connector	Terminal		
B135	1	2	2.5 Ω

Is the inspection result normal?

- YES >> GO TO 7.
- NO >> GO TO 5.

5.CHECK AWD SOLENOID CIRCUIT (2)

1. Remove AWD solenoid harness connector.
2. Check the continuity between AWD control unit harness connector and AWD solenoid harness connector.

AWD control unit		AWD solenoid		Continuity
Connector	Terminal	Connector	Terminal	
B135	1	C12	2	Yes
	2		1	

3. Check the continuity between AWD control unit harness connector and the ground.

C1204 AWD SOLENOID

< DTC/CIRCUIT DIAGNOSIS >

[TRANSFER: TY21C]

AWD control unit		—	Continuity
Connector	Terminal		
B135	1	Ground	No
	2		

Is the inspection result normal?

- YES >> GO TO 6.
- NO >> Repair or replace error-detected parts.

6.CHECK AWD SOLENOID

Check AWD solenoid. Refer to [DLN-38, "Component Inspection"](#).

Is the inspection result normal?

- YES >> GO TO 7.
- NO >> AWD solenoid is malfunctioning. Replace electric controlled coupling. Refer to [DLN-108, "Removal and Installation"](#).

7.CHECK TERMINALS AND HARNESS CONNECTORS

- Check AWD control unit pin terminals for damage or loose connection with harness connector.
- Check AWD solenoid pin terminals for damage or loose connection with harness connector.

Is the inspection result normal?

- YES >> Replace AWD control unit. Refer to [DLN-58, "Removal and Installation"](#).
- NO >> Repair or replace error-detected parts.

Component Inspection

INFOID:000000012892884

1.CHECK AWD SOLENOID

1. Turn the ignition switch OFF.
2. Disconnect AWD solenoid harness connector.
3. Check the resistance between AWD solenoid harness connector terminals.

AWD solenoid		Resistance (Approx.)
Terminal		
1	2	2.5 Ω

Is the inspection result normal?

- YES >> Inspection End.
- NO >> AWD solenoid is malfunctioning. Replace electric controlled coupling. Refer to [DLN-108, "Removal and Installation"](#).

C1205 AWD ACTUATOR RELAY

< DTC/CIRCUIT DIAGNOSIS >

[TRANSFER: TY21C]

C1205 AWD ACTUATOR RELAY

DTC Description

INFOID:000000012892885

DTC DETECTION LOGIC

Malfunction has been detected from AWD actuator relay integrated with AWD control unit, or malfunction related to AWD solenoid has been detected.

DTC No.	CONSULT screen terms (Trouble diagnosis content)	DTC detecting condition	
		Diagnosis condition	Ignition switch: ON
C1205	4WD ACTUATOR RLY (4WD actuator relay)	Signal	—
		Threshold	—
		Diagnosis delay time	—

POSSIBLE CAUSE

- Internal malfunction of AWD control unit
- Malfunction of AWD solenoid power supply circuit (ground short)

FAIL-SAFE

Front-wheel drive or shifts to 4-wheel drive (rear-wheels still have some driving torque).

DTC CONFIRMATION PROCEDURE

1. PRECONDITIONING

If "DTC CONFIRMATION PROCEDURE" has been previously conducted, always turn ignition switch OFF and wait at least 10 seconds before conducting the next test.

>> GO TO 2.

2. DTC REPRODUCTION PROCEDURE

CONSULT

1. Turn the ignition switch OFF to ON.
2. Perform "Self Diagnostic Result" mode of "ALL MODE AWD/4WD".

Is DTC "C1205" detected?

- YES >> Proceed to [DLN-39, "Diagnosis Procedure"](#).
- NO-1 >> To check malfunction symptom before repair: Refer to [GI-42, "Intermittent Incident"](#).
- NO-2 >> Confirmation after repair: Inspection End.

Diagnosis Procedure

INFOID:000000012892886

1. CHECK AWD SOLENOID CIRCUIT (1)

1. Turn the ignition switch OFF.
2. Disconnect AWD control unit harness connector.
3. Check the continuity between AWD control unit harness connector and the ground.

AWD control unit		—	Continuity
Connector	Terminal		
B135	1	Ground	Yes
	2		

Is the inspection result normal?

- YES >> GO TO 4.
- NO >> GO TO 2.

2. CHECK AWD SOLENOID

1. Disconnect AWD solenoid harness connector.

C1205 AWD ACTUATOR RELAY

< DTC/CIRCUIT DIAGNOSIS >

[TRANSFER: TY21C]

2. Check the continuity between AWD solenoid connector and the ground.

AWD solenoid		—	Continuity
Terminal			
1		Ground	No
2			

Is the inspection result normal?

YES >> GO TO 3.

NO >> AWD solenoid is malfunctioning. Replace electric controlled coupling. Refer to [DLN-108, "Removal and Installation"](#).

3.CHECK AWD SOLENOID CIRCUIT

Check the continuity between AWD control unit harness connector and the ground.

AWD control unit		—	Continuity
Connector	Terminal		
B135	1	Ground	No
	2		

Is the inspection result normal?

YES >> GO TO 4.

NO >> Repair or replace damaged parts.

4.CHECK TERMINALS AND HARNESS CONNECTORS

1. Check AWD control unit pin terminals for damage or loose connection with harness connector.
2. Check AWD solenoid pin terminals for damage or loose connection with harness connector.

Is the inspection result normal?

YES >> After connecting each harness connector, perform DTC confirmation procedure again. When DTC "C1205" is detected, replace AWD control unit. Refer to [DLN-58, "Removal and Installation"](#).

NO >> Repair or replace damaged parts.

C1210 ECM

DTC Description

INFOID:000000012892887

DTC DETECTION LOGIC

Malfunction related to engine signal has been detected.

DTC No.	CONSULT screen terms (Trouble diagnosis content)	DTC detecting condition	
		Diagnosis condition	Engine running
C1210	ENGINE SIGNAL 1 (Engine signal 1)	Signal	—
		Threshold	—
		Diagnosis delay time	—

POSSIBLE CAUSE

Malfunction of engine control system

FAIL-SAFE

Front-wheel drive or shifts to 4-wheel drive (rear-wheels still have some driving torque).

DTC CONFIRMATION PROCEDURE

1. PRECONDITIONING

If "DTC CONFIRMATION PROCEDURE" has been previously conducted, always turn ignition switch OFF and wait at least 10 seconds before conducting the next test.

>> GO TO 2.

2. DTC REPRODUCTION PROCEDURE

CONSULT

1. Start the engine and drive at 30 km/h (19 MPH) or more for approximately 1 minute.
2. Select "Self Diagnostic Result" mode of "ALL MODE AWD/4WD".

Is DTC "C1210" detected?

- YES >> Proceed to [DLN-41, "Diagnosis Procedure"](#).
- NO-1 >> To check malfunction symptom before repair: Refer to [GI-42, "Intermittent Incident"](#).
- NO-2 >> Confirmation after repair: Inspection End.

Diagnosis Procedure

INFOID:000000012892888

1. PERFORM ECM SELF-DIAGNOSIS

CONSULT

Select "Self Diagnostic Result" mode of "ENGINE".

Is any DTC detected?

- YES >> Check the DTC. Refer to [DLN-23, "DTC Index"](#).
- NO >> GO TO 2.

2. CHECK TERMINALS AND HARNESS CONNECTORS

Check AWD control unit pin terminals for damage or loose connection with harness connector.

Is inspection result normal?

- YES >> After turning the ignition switch OFF, perform DTC confirmation procedure again. If DTC "C1210" is detected, Replace AWD control unit. Refer to [DLN-58, "Removal and Installation"](#).
- NO >> Repair or replace error-detected parts.

P1804 AWD CONTROL UNIT

< DTC/CIRCUIT DIAGNOSIS >

[TRANSFER: TY21C]

P1804 AWD CONTROL UNIT

DTC Description

INFOID:000000012892889

DTC DETECTION LOGIC

Malfunction is detected in the memory (EEPROM) system of AWD control unit.

DTC No.	CONSULT screen terms (Trouble diagnosis content)	DTC detecting condition	
		Diagnosis condition	Ignition switch: ON
P1804	CONTROL UNIT 3 (Control unit 3)	Signal	—
		Threshold	—
		Diagnosis delay time	—

POSSIBLE CAUSE

Internal malfunction of AWD control unit.

FAIL-SAFE

Front-wheel drive or shifts to 4-wheel drive (rear-wheels still have some driving torque).

DTC CONFIRMATION PROCEDURE

1. PRECONDITIONING

If "DTC CONFIRMATION PROCEDURE" has been previously conducted, always turn ignition switch OFF and wait at least 10 seconds before conducting the next test.

>> GO TO 2.

2. DTC REPRODUCTION PROCEDURE

CONSULT

1. Turn the ignition switch OFF to ON.
2. Perform "Self Diagnostic Result" mode of "ALL MODE AWD/4WD".

Is DTC "P1804" detected?

- YES >> Proceed to [DLN-42. "Diagnosis Procedure"](#).
NO-1 >> To check malfunction symptom before repair: Refer to [GI-42. "Intermittent Incident"](#).
NO-2 >> Confirmation after repair: Inspection End.

Diagnosis Procedure

INFOID:000000012892890

1. PERFORM SELF-DIAGNOSIS AGAIN

CONSULT

Perform "DTC CONFIRMATION PROCEDURE" (self-diagnosis) again. Refer to [DLN-42. "DTC Description"](#).

Is DTC "P1804" detected?

- YES >> Replace AWD control unit. Refer to [DLN-58. "Removal and Installation"](#).
NO >> Check AWD control unit pin terminals for damage or loose connection with harness connector. If any items are damaged, repair or replace error-detected parts.

P181F INCOMPLETE CALIBRATION

< DTC/CIRCUIT DIAGNOSIS >

[TRANSFER: TY21C]

P181F INCOMPLETE CALIBRATION

DTC Description

INFOID:000000012892891

DTC DETECTION LOGIC

When incomplete writing unit characteristics of rear final drive is detected.

DTC No.	CONSULT screen terms (Trouble diagnosis content)	DTC detecting condition	
		Diagnosis condition	Ignition switch: ON
P181F	INCOMP CALIBRATION (Incomplete calibration)	Signal	—
		Threshold	—
		Diagnosis delay time	—

POSSIBLE CAUSE

Writing unit characteristics are incomplete.

FAIL-SAFE

Front-wheel drive or shifts to 4-wheel drive (rear-wheels still have some driving torque).

DTC CONFIRMATION PROCEDURE

1. PRECONDITIONING

If "DTC CONFIRMATION PROCEDURE" has been previously conducted, always turn ignition switch OFF and wait at least 10 seconds before conducting the next test.

>> GO TO 2.

2. DTC REPRODUCTION PROCEDURE

CONSULT

1. Turn the ignition switch OFF to ON.
2. Perform "Self Diagnostic Result" mode of "ALL MODE AWD/4WD".

Is DTC "P181F" detected?

- YES >> Proceed to [DLN-43, "Diagnosis Procedure"](#).
- NO-1 >> To check malfunction symptom before repair: Refer to [GI-42, "Intermittent Incident"](#).
- NO-2 >> Confirmation after repair: Inspection End.

Diagnosis Procedure

INFOID:000000012892892

1. PERFORM WRITING UNIT CHARACTERISTICS

1. Erase s"Self Diagnostic Result" mode of "ALL MODE AWD/4WD".
2. Perform writing unit characteristics. Refer to [DLN-33, "Work Procedure"](#).
3. Turn the ignition switch OFF to ON.
4. Perform "Self Diagnostic Result" mode of "ALL MODE AWD/4WD".

Is any DTC except "P181F" detected?

- YES >> Perform trouble diagnosis for detected DTC. Refer to [DLN-23, "DTC Index"](#).
- NO >> GO TO 2.

2. PERFORM SELF-DIAGNOSIS AGAIN

CONSULT

Perform "DTC CONFIRMATION PROCEDURE" (self-diagnosis) again. Refer to [DLN-23, "DTC Index"](#).

Is DTC "P181F" detected?

- YES >> Replace AWD control unit. Refer to [DLN-58, "Removal and Installation"](#).
- NO >> Check AWD control unit pin terminals for damage or loose connection with harness connector. If any items are damaged, repair or replace error-detected parts.

U1000 CAN COMM CIRCUIT

< DTC/CIRCUIT DIAGNOSIS >

[TRANSFER: TY21C]

U1000 CAN COMM CIRCUIT

DTC Description

INFOID:000000012892893

CAN (Controller Area Network) is a serial communication line for real time application. It is an on-vehicle multiplex communication line with high data communication speed and excellent error detection ability. Many electronic control units are equipped onto a vehicle, and each control unit shares information and links with other control units during operation (not independent). In CAN communication, control units are connected with 2 communication lines (CAN-H line, CAN-L line) allowing a high rate of information transmission with less wiring. Each control unit communicate data but selectively reads required data only.

DTC DETECTION LOGIC

AWD control unit is not transmitting/receiving CAN communication signal for 2 seconds or more.

DTC No.	CONSULT screen terms (Trouble diagnosis content)	DTC detecting condition	
U1000	CAN COMM CIRCUIT (CAN communication circuit)	Diagnosis condition	Ignition switch: ON
		Signal	CAN communication signal
		Threshold	—
		Diagnosis delay time	2 seconds or more.

POSSIBLE CAUSE

- CAN communication error
- Internal malfunction of AWD control unit

FAIL-SAFE

Front-wheel drive or shifts to 4-wheel drive (rear-wheels still have some driving torque).

DTC CONFIRMATION PROCEDURE

1. PRECONDITIONING

If "DTC CONFIRMATION PROCEDURE" has been previously conducted, always turn ignition switch OFF and wait at least 10 seconds before conducting the next test.

>> GO TO 2.

2. DTC REPRODUCTION PROCEDURE

CONSULT

1. Turn the ignition switch OFF to ON.
2. Perform "Self Diagnostic Result" mode of "ALL MODE AWD/4WD".

Is DTC "U1000" detected?

- YES >> Proceed to [DLN-44, "Diagnosis Procedure"](#).
- NO-1 >> To check malfunction symptom before repair: Refer to [GI-42, "Intermittent Incident"](#).
- NO-2 >> Confirmation after repair: Inspection End

Diagnosis Procedure

INFOID:000000012892894

Proceed to [LAN-21, "Trouble Diagnosis Flow Chart"](#).

U1010 CONTROL UNIT (CAN)

< DTC/CIRCUIT DIAGNOSIS >

[TRANSFER: TY21C]

U1010 CONTROL UNIT (CAN)

DTC Description

INFOID:000000012892895

CAN (Controller Area Network) is a serial communication line for real time application. It is an on-vehicle multiplex communication line with high data communication speed and excellent error detection ability. Many electronic control units are equipped onto a vehicle, and each control unit shares information and links with other control units during operation (not independent). In CAN communication, control units are connected with 2 communication lines (CAN-H line, CAN-L line) allowing a high rate of information transmission with less wiring. Each control unit communicate data but selectively reads required data only.

DTC DETECTION LOGIC

Detecting error during the initial diagnosis of CAN controller of AWD control unit.

DTC No.	CONSULT screen terms (Trouble diagnosis content)	DTC detecting condition	
		Diagnosis condition	Ignition switch: ON
U1010	CONTROL UNIT (CAN) [Control unit (CAN)]	Signal	—
		Threshold	—
		Diagnosis delay time	—

POSSIBLE CAUSE

Internal malfunction of AWD control unit

FAIL-SAFE

Front-wheel drive or shifts to 4-wheel drive (rear-wheels still have some driving torque).

DTC CONFIRMATION PROCEDURE

1. PRECONDITIONING

If "DTC CONFIRMATION PROCEDURE" has been previously conducted, always turn ignition switch OFF and wait at least 10 seconds before conducting the next test.

>> GO TO 2.

2. DTC REPRODUCTION PROCEDURE

CONSULT

1. Turn the ignition switch OFF to ON.
2. Perform "Self Diagnostic Result" mode of "ALL MODE AWD/4WD".

Is DTC "U1010" detected?

- YES >> Proceed to [DLN-45, "Diagnosis Procedure"](#).
- NO-1 >> To check malfunction symptom before repair: Refer to [GI-42, "Intermittent Incident"](#).
- NO-2 >> Confirmation after repair: Inspection End.

Diagnosis Procedure

INFOID:000000012892896

1. CHECK AWD CONTROL UNIT

Check AWD control unit harness connector for disconnection and deformation.

Is the inspection result normal?

- YES >> Replace AWD control unit. Refer to [DLN-58, "Removal and Installation"](#).
- NO >> Repair or replace error-detected parts.

POWER SUPPLY AND GROUND CIRCUIT

< DTC/CIRCUIT DIAGNOSIS >

[TRANSFER: TY21C]

POWER SUPPLY AND GROUND CIRCUIT

Diagnosis Procedure

INFOID:000000012892897

1. CHECK AWD CONTROL UNIT POWER SUPPLY (1)

1. Turn the ignition switch OFF.
2. Disconnect AWD control unit harness connector.
3. Check the voltage between AWD control unit harness connector and ground.

AWD control unit		—	Voltage (Approx.)
Connector	Terminal		
B135	7	Ground	0 V

4. Turn the ignition switch ON.
CAUTION:
Never start the engine.
5. Check the voltage between AWD control unit harness connector and ground.

AWD control unit		—	Voltage
Connector	Terminal		
B135	7	Ground	Battery voltage

Is the inspection result normal?

- YES >> GO TO 3.
NO >> GO TO 2.

2. CHECK AWD CONTROL UNIT POWER SUPPLY (2)

1. Turn the ignition switch OFF.
2. Check the 10A fuse (#46).
3. Disconnect IPDM E/R harness connector.
4. Check the continuity between AWD control unit harness connector and IPDM E/R harness connector.

AWD control unit		IPDM E/R		Continuity
Connector	Terminal	Connector	Terminal	
B135	7	E119	19	Yes

5. Check the continuity between AWD control unit harness connector and the ground.

AWD control unit		—	Continuity
Connector	Terminal		
B135	7	Ground	No

Is the inspection result normal?

- YES >> Perform the trouble diagnosis for ignition power supply circuit. Refer to [PG-47, "Wiring Diagram - IGNITION POWER SUPPLY -"](#).
- NO >> Repair or replace error-detected parts.

3. CHECK AWD CONTROL UNIT POWER SUPPLY (3)

1. Turn the ignition switch OFF.
2. Check the voltage between AWD control unit harness connector and ground.

AWD control unit		—	Voltage
Connector	Terminal		
B135	15	Ground	Battery voltage

3. Turn the ignition switch ON.
CAUTION:

POWER SUPPLY AND GROUND CIRCUIT

< DTC/CIRCUIT DIAGNOSIS >

[TRANSFER: TY21C]

Never start the engine.

4. Check the voltage between AWD control unit harness connector and ground.

AWD control unit		—	Voltage
Connector	Terminal		
B135	15	Ground	Battery voltage

Is the inspection result normal?

YES >> GO TO 5.

NO >> GO TO 4.

4.CHECK AWD CONTROL UNIT POWER SUPPLY (4)

1. Turn the ignition switch OFF.
2. Check the 10A fuse (#25).
3. Disconnect fuse block (J/B) harness connector.
4. Check the continuity between AWD control unit harness connector and fuse block (J/B) harness connector.

AWD control unit		Fuse block (J/B)		Continuity
Connector	Terminal	Connector	Terminal	
B135	15	M3	2N	Yes

5. Check the continuity between AWD control unit harness connector and the ground.

AWD control unit		—	Continuity
Connector	Terminal		
B135	15	Ground	No

Is the inspection result normal?

YES >> Perform the trouble diagnosis for power supply circuit. Refer to [PG-16, "Wiring Diagram - BATTERY POWER SUPPLY -"](#).

NO >> Repair or replace error-detected parts.

5.CHECK AWD SOLENOID POWER SUPPLY (1)

1. Turn the ignition switch OFF.
2. Disconnect AWD solenoid harness connector.
3. Check the voltage between AWD control unit harness connector and ground.

AWD control unit		—	Voltage
Connector	Terminal		
B135	9	Ground	Battery voltage

4. Turn the ignition switch ON.

CAUTION:

Never start the engine.

5. Check the voltage between AWD control unit harness connector and ground.

AWD control unit		—	Voltage
Connector	Terminal		
B135	9	Ground	Battery voltage

Is the inspection result normal?

YES >> GO TO 7.

NO >> GO TO 6.

6.CHECK AWD SOLENOID POWER SUPPLY (2)

1. Turn the ignition switch OFF.

POWER SUPPLY AND GROUND CIRCUIT

< DTC/CIRCUIT DIAGNOSIS >

[TRANSFER: TY21C]

2. Check the 10A fuse (#62)
3. Check the harness for open or short between AWD control unit harness connector No.9 terminal and 10A fuse (#62).

Is the inspection result normal?

YES >> Perform the trouble diagnosis for power supply circuit. Refer to [PG-16. "Wiring Diagram - BATTERY POWER SUPPLY -"](#).

NO >> Repair or replace error-detected parts.

7. CHECK AWD CONTROL UNIT GROUND

1. Turn the ignition switch OFF.
2. Check the continuity between AWD control unit harness connector and ground.

AWD control unit		—	Continuity
Connector	Terminal		
B135	10	Ground	Yes
	11		

Is the inspection result normal?

YES >> Inspection End.

NO >> Repair or replace error-detected parts.

AWD WARNING ICON/DISPLAY

Diagnosis Procedure

INFOID:000000012892898

1.CHECK POWER SUPPLY AND GROUND CIRCUIT

Perform the trouble diagnosis for power supply and ground circuit. Refer to [DLN-46, "Diagnosis Procedure"](#).

Is the inspection result normal?

YES >> GO TO 2.

NO >> Repair or replace the error-detected parts.

2.PERFORM SELF-DIAGNOSIS (AWD CONTROL UNIT)**CONSULT**

Select "Self Diagnostic Result" mode of "ALL MODE AWD/4WD".

Is any detected?

YES >> Check the DTC. Refer to [DLN-23, "DTC Index"](#).

NO >> GO TO 3.

3.PERFORM SELF-DIAGNOSIS (COMBINATION METER)**CONSULT**

Select "Self Diagnostic Result" mode of "METER/M&A".

Is any detected?

YES >> Check the DTC. Refer to [MWI-29, "DTC Index"](#).

NO >> Perform the trouble diagnosis for combination meter power supply circuit. Refer to [DLN-49, "Diagnosis Procedure"](#).

A
B
C
DLN
E
F
G
H
I
J
K
L
M
N
O
P

SYMPTOM DIAGNOSIS

AWD ERROR IS DISPLAYED ON INFORMATION DISPLAY

Description

INFOID:0000000012892899

AWD warning icon/display (AWD Error: See Owner's Manual) is displayed on information display after the engine started.

Diagnosis Procedure

INFOID:0000000012892900

1.PERFORM SELF-DIAGNOSIS

CONSULT

Select "Self Diagnostic Result" mode of "ALL MODE AWD/4WD".

Is any DTC detected?

- YES >> Check the DTC. Refer to [DLN-23, "DTC Index"](#).
- NO >> GO TO 2.

2.CHECK AWD WARNING ICON/DISPLAY

Perform the trouble diagnosis of the AWD warning icon/display. Refer to [DLN-49, "Diagnosis Procedure"](#).

Is the inspection result normal?

- YES >> Check each harness connector pin terminal for malfunction or disconnection.
- NO >> Repair or replace the error-detected parts.

HEAVY TIGHT-CORNER BRAKING SYMPTOM OCCURS

< SYMPTOM DIAGNOSIS >

[TRANSFER: TY21C]

HEAVY TIGHT-CORNER BRAKING SYMPTOM OCCURS

Description

INFOID:000000012892901

Heavy tight-corner braking symptom occurs when the vehicle is driven and the steering wheel is turned fully to either side after the engine is started.

NOTE:

Light tight-corner braking symptom may occur depending on driving conditions. This is not malfunction.

Diagnosis Procedure

INFOID:000000012892902

1. PERFORM ECM SELF-DIAGNOSIS

CONSULT

Select "Self Diagnostic Result" mode of "ENGINE".

Is any DTC detected?

- YES >> Check the DTC. Refer to [EC-105, "DTC Index"](#).
- NO >> GO TO 2.

2. PERFORM SELF-DIAGNOSIS

CONSULT

Select "Self Diagnostic Result" mode of "ALL MODE AWD/4WD".

Is DTC "U1000" detected?

- YES >> Proceed to [LAN-21, "Trouble Diagnosis Flow Chart"](#).
- NO >> GO TO 3.

3. CHECK AWD SOLENOID

Perform the trouble diagnosis of the AWD solenoid. Refer to [DLN-36, "Diagnosis Procedure"](#).

Is the inspection result normal?

- YES >> GO TO 4.
- NO >> Repair or replace the error-detected parts.

4. CHECK ELECTRIC CONTROLLED COUPLING

1. Turn the ignition switch OFF.
2. Set the transaxle to neutral. Release the parking brake.
3. Lift up the vehicle.
4. Rotate the propeller shaft by hand.
5. Hold rear wheel of right and left lightly.

Does rear wheel rotate?

- YES >> Replace electric controlled coupling for mechanical malfunction (clutch sticking etc.). Refer to [DLN-108, "Removal and Installation"](#).
- NO >> Check each harness connector pin terminal for disconnection.

VEHICLE DOES NOT ENTER AWD MODE

< SYMPTOM DIAGNOSIS >

[TRANSFER: TY21C]

VEHICLE DOES NOT ENTER AWD MODE

Description

INFOID:000000012892903

Vehicle does not enter 4-wheel drive mode even though AWD warning icon/display is not displayed.

Diagnosis Procedure

INFOID:000000012892904

1. CHECK AWD WARNING ICON/DISPLAY

Perform the trouble diagnosis of the AWD warning icon/display. Refer to [DLN-49, "Diagnosis Procedure"](#).

Is the inspection result normal?

YES >> GO TO 2.

NO >> Repair or replace the error-detected parts.

2. CHECK PARKING BRAKE SWITCH SIGNAL

CONSULT

Check "P BRAKE SW" of CONSULT "Data Monitor" for "ALL MODE AWD/4WD".

Monitor Item	Condition	Status
P BRAKE SW	When the parking brake pedal is operation.	On
	When the parking brake pedal is not operation.	Off

Is the inspection result normal?

YES >> GO TO 3.

NO >> Proceed to [BRC-343, "Component Function Check"](#).

3. CRUISE TEST

Drive the vehicle for a period of time.

Does any symptom occur?

YES >> Replace electric controlled coupling for mechanical malfunction (mechanical engagement of clutch is not possible). Refer to [DLN-108, "Removal and Installation"](#).

NO >> Check each harness connector pin terminal for disconnection.

AWD HIGH TEMP IS DISPLAYED ON INFORMATION DISPLAY

< SYMPTOM DIAGNOSIS >

[TRANSFER: TY21C]

AWD HIGH TEMP IS DISPLAYED ON INFORMATION DISPLAY

Description

INFOID:000000012892905

While driving, AWD warning icon/display (AWD High Temp. Stop vehicle) is displayed on information display and it turns OFF after 1 minute.

- This symptom protects drivetrain parts when a heavy load is applied to the electric controlled coupling and multiple disc clutch temperature increases. Also, optional distribution of torque sometimes becomes rigid before icon/display is displayed. Both cases are not malfunction. Refer to [DLN-22. "Protection Function"](#).
- When this symptom occurs, stop vehicle and allow it to idle for some times. Displays will stop and system will be restored.

A
B
C
DLN
E
F
G
H
I
J
K
L
M
N
O
P

TIRE SIZE INCORRECT IS DISPLAYED ON INFORMATION DISPLAY

< SYMPTOM DIAGNOSIS >

[TRANSFER: TY21C]

TIRE SIZE INCORRECT IS DISPLAYED ON INFORMATION DISPLAY

Description

INFOID:000000012892906

While driving, AWD warning icon/display (Tire Size Incorrect: See Owner's Manual) is displayed on information display.

Diagnosis Procedure

INFOID:000000012892907

1. CHECK TIRE

Check the following.

- Tire pressure
- Wear condition
- Front and rear tire size (There is no difference between front and rear tires.)

Is the inspection result normal?

YES >> GO TO 2.

NO >> Repair or replace error-detected parts. And then, drive the vehicle at speed of 20 km/h (12 MPH) or more for 5 seconds or more. Improper size information is initialized accordingly.

2. CHECK INPUT SIGNAL OF TIRE DIAMETER

CONSULT

1. Start the engine.
2. Drive at 20 km/h (12 MPH) or more for approximately 4 minutes continually.
3. Check "DIS-TIRE MONI" of CONSULT "Data Monitor" for "ALL MODE AWD/4WD".

Does the item on "Data Monitor" indicate "0 - 4 mm"?

YES >> Inspection End.

NO >> GO TO 3.

3. TERMINAL INSPECTION

Check AWD control unit harness connector for disconnection.

Is the inspection result normal?

YES >> Replace AWD control unit. Refer to [DLN-58, "Removal and Installation"](#).

NO >> Repair or replace the error-detected parts.

NOISE, VIBRATION AND HARSHNESS (NVH) TROUBLESHOOTING

< SYMPTOM DIAGNOSIS >

[TRANSFER: TY21C]

NOISE, VIBRATION AND HARSHNESS (NVH) TROUBLESHOOTING

NVH Troubleshooting Chart

INFOID:000000012892908

Use the chart below to find the cause of the symptom. The numbers indicate the order of the inspection. If necessary, repair or replace these parts.

Reference		DLN-56. "Inspection"			-		DLN-62. "Exploded View"		DLN-62. "Exploded View"		DLN-69. "Inspection", DLN-78. "Inspection"		DLN-69. "Inspection", DLN-78. "Inspection"	
		TRANSFER OIL (Level low)	TRANSFER OIL (Wrong)	TRANSFER OIL (Level too high)	LIQUID GASKET (Damaged)	O-RING (Worn or damaged)	OIL SEAL (Worn or damaged)	GEAR (Worn or damaged)	BEARING (Worn or damaged)					
Symptom	Noise	1	2				3	3	3					
	Transfer oil leakage		3	1	2	2	2							

A
B
C
DLN
E
F
G
H
I
J
K
L
M
N
O
P

PERIODIC MAINTENANCE

TRANSFER OIL

Inspection

INFOID:000000012892909

TRANSFER OIL LEAKS

Check that transfer oil is not leaking from transfer assembly or around it.

TRANSFER OIL LEVEL

CAUTION:

Do not start engine while checking transfer oil level.

1. Remove filler plug (1) and gasket.

⇐ : Front

2. Transfer oil level (A) should be level with bottom of filler plug hole. Add transfer oil if necessary. Refer to [MA-12, "Fluids and Lubricants"](#).
3. Set a new gasket onto filler plug, and install it in the transfer and tighten to specified torque. Refer to [DLN-62, "Exploded View"](#).

CAUTION:

Do not reuse gasket.

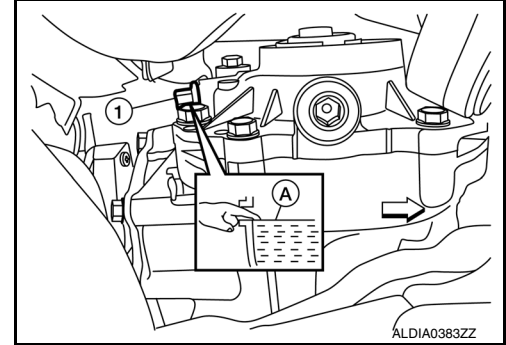

ALDIA0383ZZ

Draining

INFOID:000000012892910

CAUTION:

Do not start engine while working.

1. Run the vehicle to warm up the transfer unit sufficiently.
2. Stop the engine and remove drain plug (1) and gasket and drain the transfer oil.

⇐ : Front

3. Set a new gasket onto filler plug, and install it in the transfer and tighten to specified torque. Refer to [DLN-62, "Exploded View"](#).

CAUTION:

Do not reuse gasket.

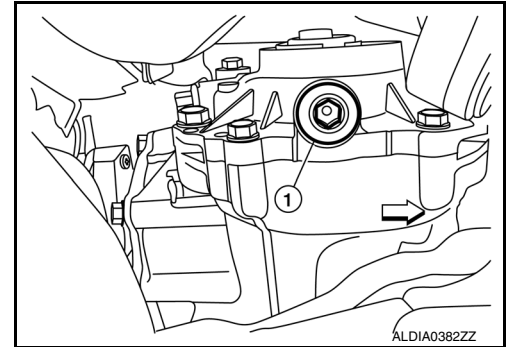

ALDIA0382ZZ

Refilling

INFOID:000000012892911

CAUTION:

Do not start engine while checking transfer oil level.

1. Remove filler plug (1).
2. Fill with new transfer oil to the specified level (A) near the filler plug hole.

⇐ : Front

Transfer oil grade and viscosity

: Refer to [MA-12, "Fluids and Lubricants"](#).

Transfer oil capacity

: Refer to [DLN-83, "General Specifications"](#).

3. Set a new gasket onto filler plug, and install it in the transfer and tighten to specified torque. Refer to [DLN-62, "Exploded View"](#).

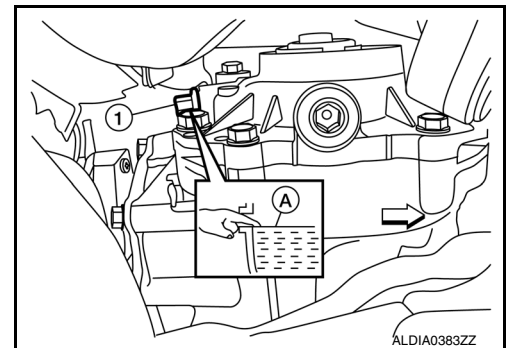

ALDIA0383ZZ

TRANSFER OIL

< PERIODIC MAINTENANCE >

[TRANSFER: TY21C]

CAUTION:
Do not reuse gasket.

A

B

C

DLN

E

F

G

H

I

J

K

L

M

N

O

P

AWD CONTROL UNIT

< REMOVAL AND INSTALLATION >

[TRANSFER: TY21C]

REMOVAL AND INSTALLATION

AWD CONTROL UNIT

Exploded View

INFOID:000000012892912

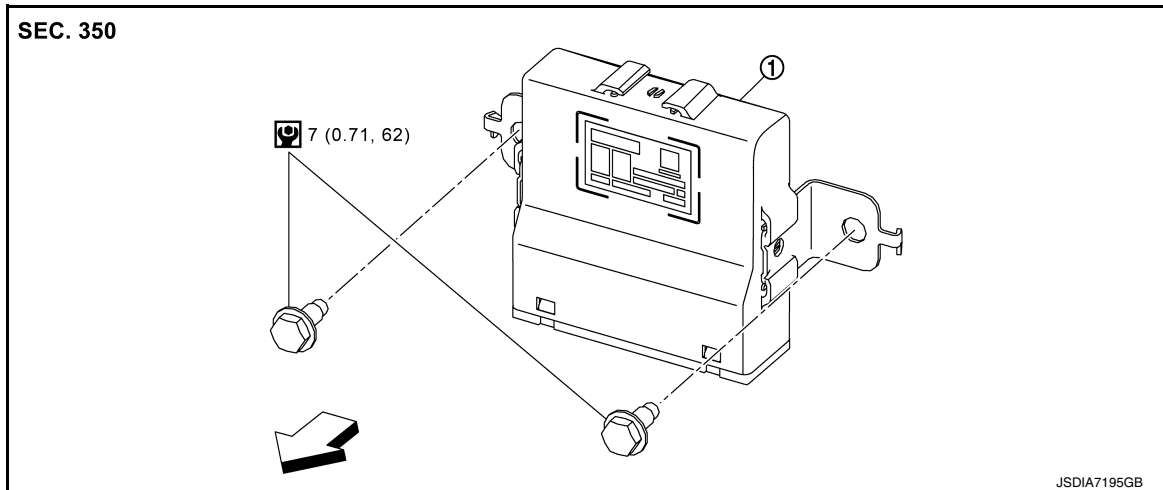

1. AWD control unit

⇐ Front

Removal and Installation

INFOID:000000012892913

REMOVAL

1. Remove back door kicking plate. Refer to [INT-23. "KICKING PLATE : Removal and Installation - Rear Kicking Plate"](#).
2. Disconnect harness connector from the AWD control unit (1).
3. Remove AWD control unit bolts (A).
⇐: Front
4. Remove AWD control unit (1).

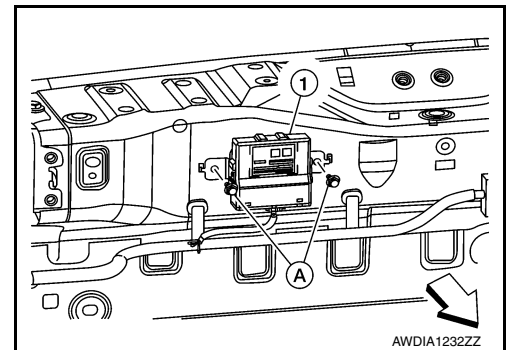

INSTALLATION

Installation is in the reverse order of removal.

CAUTION:

- Do not drop or shock AWD control unit.
- When replacing AWD control unit, perform "ADDITIONAL SERVICE WHEN REPLACING AWD CONTROL UNIT". Refer to [DLN-32. "Description"](#).

TRANSFER COVER OIL SEAL

< REMOVAL AND INSTALLATION >

[TRANSFER: TY21C]

TRANSFER COVER OIL SEAL

Removal and Installation

INFOID:000000012892914

NOTE:

- Replacement on vehicle may cause damage to transfer cover, and may cause a transfer oil leak.
- If transfer cover oil seal requires replacement, remove the transfer assembly from the vehicle before replacing transfer cover oil seal. Refer to [DLN-63. "Disassembly and Assembly"](#).

A

B

C

DLN

E

F

G

H

I

J

K

L

M

N

O

P

TRANSFER ASSEMBLY

< UNIT REMOVAL AND INSTALLATION >

[TRANSFER: TY21C]

UNIT REMOVAL AND INSTALLATION

TRANSFER ASSEMBLY

Exploded View

INFOID:000000012892915

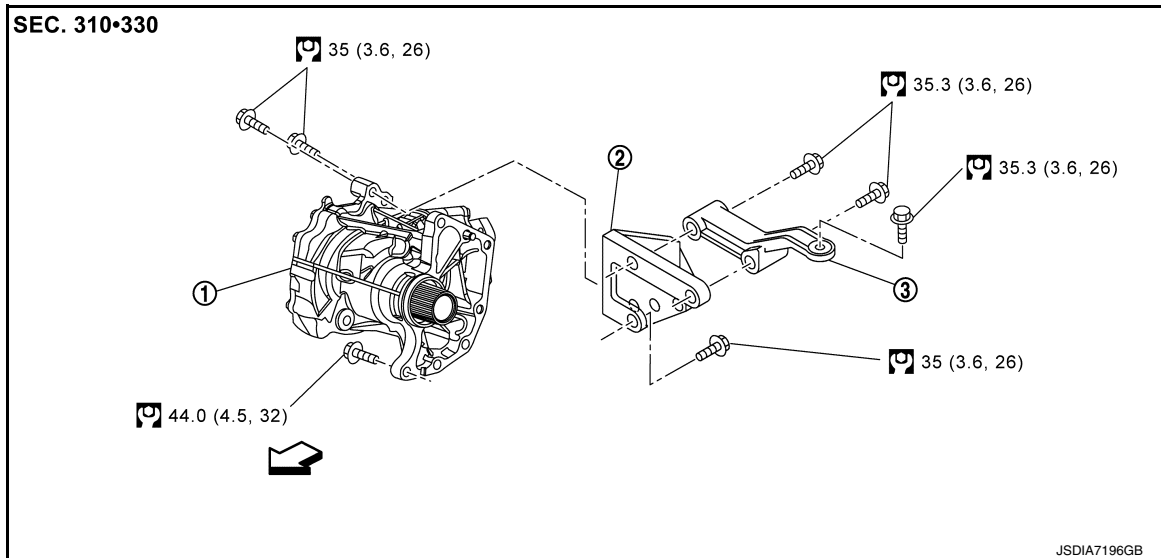

① Transfer assembly

② Transfer gusset

③ Rear gusset

↔: Vehicle front

⊞: N·m (kg·m, ft·lb)

Removal and Installation

INFOID:000000012892916

NOTE:

When removing components such as hoses, tubes/lines, etc., cap or plug openings to prevent fluid from spilling.

REMOVAL

1. Drain the transfer oil. Refer to [DLN-56, "Draining"](#).
2. Remove exhaust manifold (RH). Refer to [EM-35, "Removal and Installation \(bank 1\)"](#).

CAUTION:

Handle carefully to avoid any shock to three way catalyst.

3. Support transaxle with a suitable jack.
4. Remove the steering gear. Refer to [ST-42, "Removal and Installation - FWD"](#) (FWD) or [ST-44, "Removal and Installation - AWD"](#) (AWD).

5. Remove rear gusset and transfer gusset.
6. Remove transaxle assembly to transfer assembly bolts.

CAUTION:

Be careful not to damage gear ring oil seal inside of CVT.

Bolt No.	(A)	(B)
Quantity	4	2
Bolt length "ℓ" mm (in)	44 (1.73)	42 (1.65)

7. Remove transfer assembly from the vehicle.

CAUTION:

- Do not damage air breather hose.

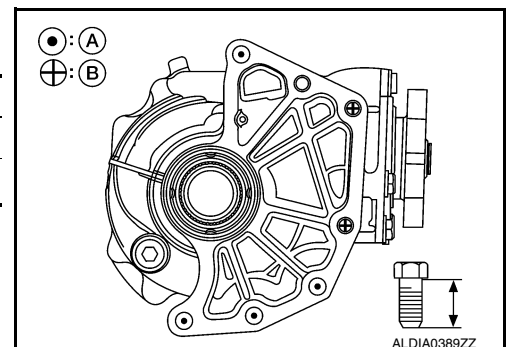

TRANSFER ASSEMBLY

< UNIT REMOVAL AND INSTALLATION >

[TRANSFER: TY21C]

- After removing transfer from transaxle, always replace differential side oil seal of the transaxle side with new one. Refer to [TM-219, "Removal and Installation"](#).

INSTALLATION

Installation is in the reverse order of removal.

- When installing the transfer to the transaxle, install the bolts following the standard below.

Bolt No.	(A)	(B)
Quantity	4	2
Bolt length "ℓ" mm (in)	44 (1.73)	42 (1.65)

CAUTION:

- When installing transfer to transaxle, be careful not to damage oil seal of transaxle.
- Do not reuse differential side oil seal.
- Check transfer oil level and check for transfer oil leaks after installation. Refer to [DLN-56, "Refilling"](#).

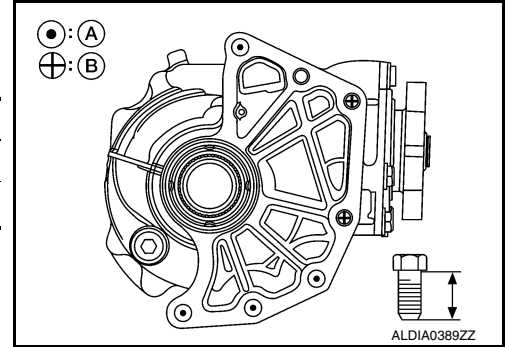

A
B
C
DLN
E
F
G
H
I
J
K
L
M
N
O
P

TRANSFER COVER

< UNIT DISASSEMBLY AND ASSEMBLY >

[TRANSFER: TY21C]

UNIT DISASSEMBLY AND ASSEMBLY

TRANSFER COVER

Exploded View

INFOID:000000012892917

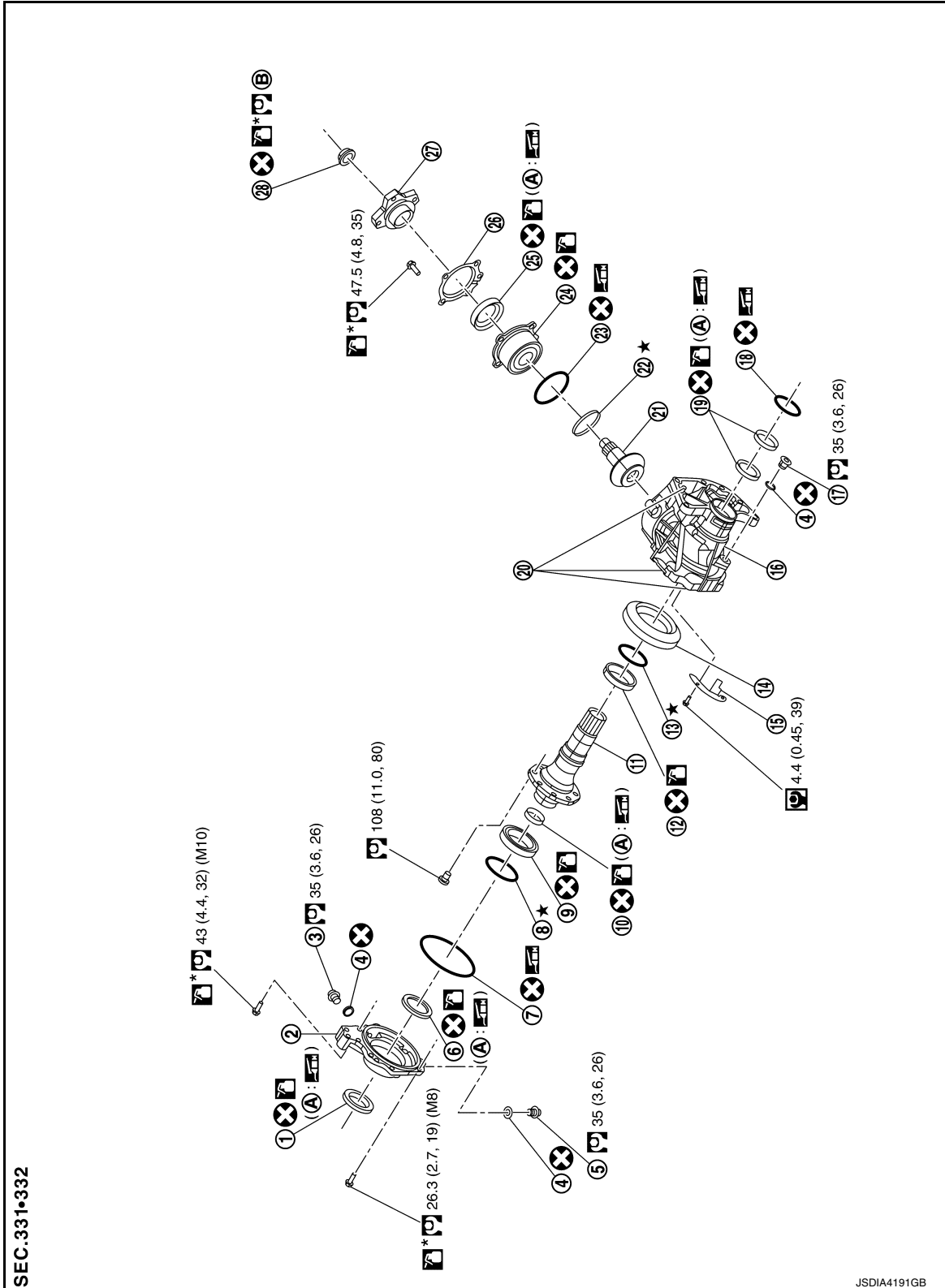

SEC.331-332

JSDIA4191GB

TRANSFER COVER

< UNIT DISASSEMBLY AND ASSEMBLY >

[TRANSFER: TY21C]

- | | | | |
|---|---|---|-----|
| ① Oil seal | ② Transfer cover | ③ Filler plug | A |
| ④ Gasket | ⑤ Drain plug | ⑥ Oil seal | B |
| ⑦ O-ring | ⑧ Ring gear bearing adjusting shim (transfer cover side) | ⑨ Ring gear bearing (transfer cover side) | B |
| ⑩ Drive shaft oil seal | ⑪ Ring gear shaft | ⑫ Ring gear bearing (transfer case side) | C |
| ⑬ Ring gear bearing adjusting shim (transfer case side) | ⑭ Ring gear | ⑮ Baffle plate | C |
| ⑯ Transfer case | ⑰ Plug | ⑱ O-ring | DLN |
| ⑲ Oil seal | ⑳ Dowel pin | ㉑ Drive pinion | DLN |
| ㉒ Drive pinion adjusting shim | ㉓ O-ring | ㉔ Pinion bearing assembly | DLN |
| ㉕ Oil seal | ㉖ Dust cover | ㉗ Companion flange | E |
| ㉘ Pinion lock nut | | | F |
| Ⓐ Oil seal lip | Ⓑ Comply with the assembly procedure when tightening. Refer to DLN-72, "Disassembly and Assembly" . | | G |

: N·m (kg-m, in-lb)

: N·m (kg-m, ft-lb)

: Always replace after every disassembly.

: Apply gear oil.

: Apply anti-corrosive oil.

: Apply multi-purpose grease.

★: Select with proper thickness.

Disassembly and Assembly

INFOID:000000012892918

DISASSEMBLY

1. Remove transfer cover mounting bolts (←).

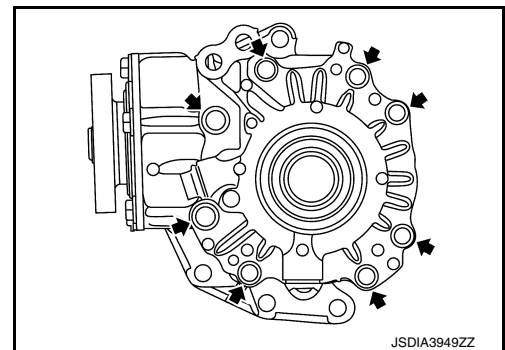

2. Lightly tap transfer cover ① with a plastic hammer to remove transfer cover.
3. Remove O-ring from transfer cover.

CAUTION:

 - Never use a tool.
 - Never damage transfer cover.

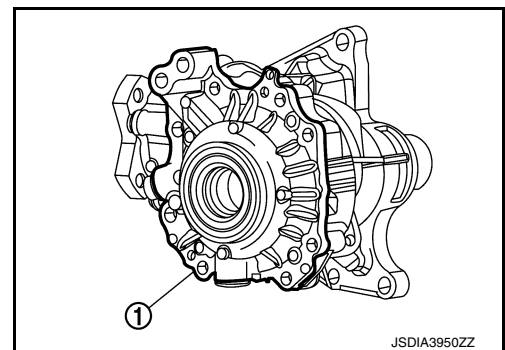

TRANSFER COVER

< UNIT DISASSEMBLY AND ASSEMBLY >

[TRANSFER: TY21C]

4. Lightly tap the metal part of oil seals ① with punch from back side of transfer cover to remove oil seals.

CAUTION:

When removing, never damage the transfer cover by scooping it out with a tool.

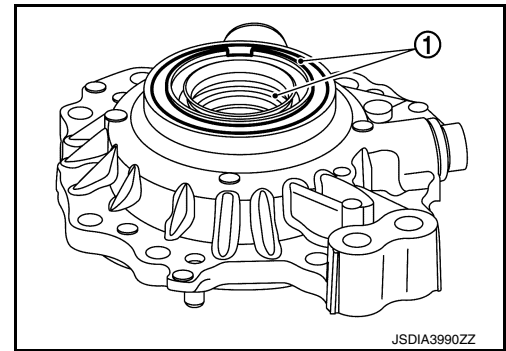

5. Remove the ring gear bearing adjusting shim (transfer cover side) ① and ring gear bearing outer race (transfer cover side) ② using drift (commercial service tool).
6. Remove drain plug and gasket.
7. Remove filler plug and gasket.
8. Perform inspection after disassembly. Refer to [DLN-65. "Inspection"](#).

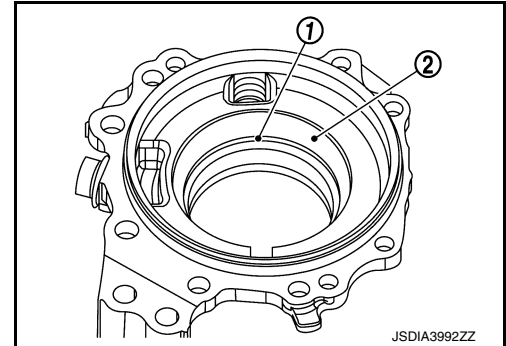

ASSEMBLY

1. Select the ring gear bearing adjusting shim (transfer cover side). Refer to [DLN-74. "Adjustment"](#).
2. Install the selected ring gear bearing adjusting shim (transfer cover side) ① and ring gear bearing outer race (transfer cover side) ② using drift (commercial service tool).

CAUTION:

- Never reuse ring gear bearing.
- Apply gear oil to the ring gear bearing.

3. Install gasket onto drain plug and install them to transfer cover.

CAUTION:

Never reuse gasket.

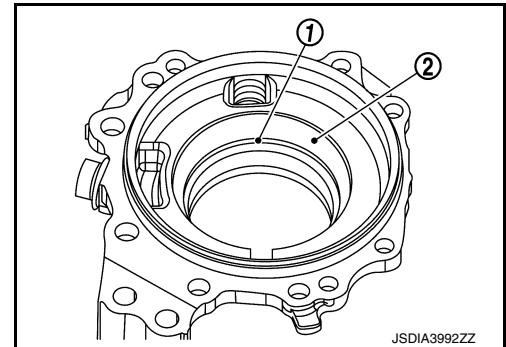

4. Install the transfer cover to the transfer case, and apply anti-corrosive oil onto thread and seats on the mounting bolts. Then tighten mounting bolts to the specified torque.

A : M10 bolt

B : M8 bolt

NOTE:

At this timing, O-ring installing to transfer cover is not necessary. Install O-ring after tooth contact is checked.

5. Check backlash, tooth contact, total preload and companion flange runout. Refer to [DLN-74. "Adjustment"](#).

CAUTION:

Measure the total preload without oil seals of transfer cover and transfer case.

6. Remove transfer cover to install O-ring.
7. Apply multi-purpose grease lightly and evenly onto an O-ring, and install it to the transfer cover.

CAUTION:

- Never reuse O-ring.
- When installing O-ring, never use a tool.
- Never damage O-ring.

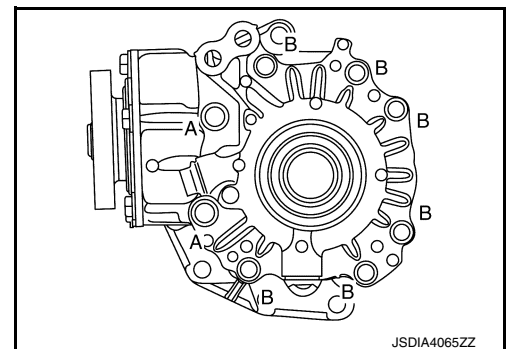

TRANSFER COVER

< UNIT DISASSEMBLY AND ASSEMBLY >

[TRANSFER: TY21C]

8. Install the transfer cover to the transfer case, and apply anti-corrosive oil onto thread and seats on the mounting bolts. Then tighten mounting bolts to the specified torque.

- A : M10 bolt
B : M8 bolt

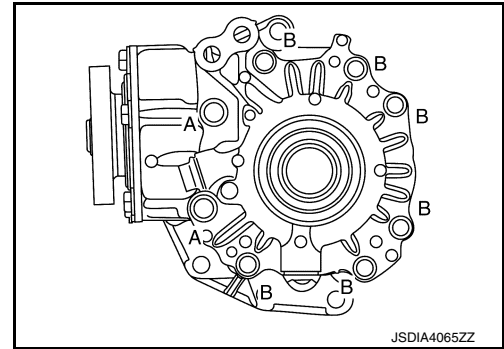

9. Using drift (commercial service tool), drive the transfer cover oil seals.

- A : 10.3 +0.6/-0 mm (0.406 +0.024/-0 in)
B : 0 +0.6/-0 mm (0 +0.024/-0 in)

CAUTION:

- When checking the total preload torque, measure it without the oil seal, then install the oil seal.
- Never reuse the oil seal.
- When installing, never incline oil seal.
- Apply multi-purpose grease onto oil seal lips, and gear oil onto the circumference of the oil seal.

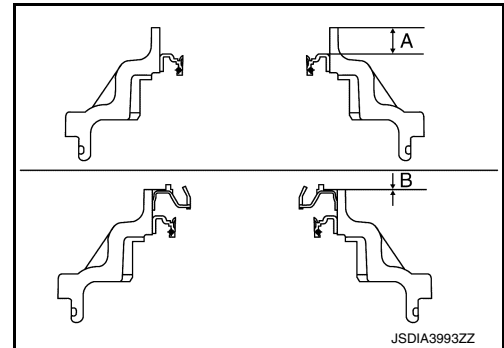

10. Install gasket onto filler plug and install them to transfer cover.

CAUTION:

- Never reuse gasket.
- Install filler plug after oil is filled.

Inspection

INFOID:000000012892919

INSPECTION AFTER DISASSEMBLY

Check items below. If necessary, replace them with new ones.

Transfer cover

Check the bearing mounting surface for wear, cracks and damages.

A
B
C
DLN
E
F
G
H
I
J
K
L
M
N
O
P

RING GEAR SHAFT

< UNIT DISASSEMBLY AND ASSEMBLY >

[TRANSFER: TY21C]

RING GEAR SHAFT

Exploded View

INFOID:000000012892920

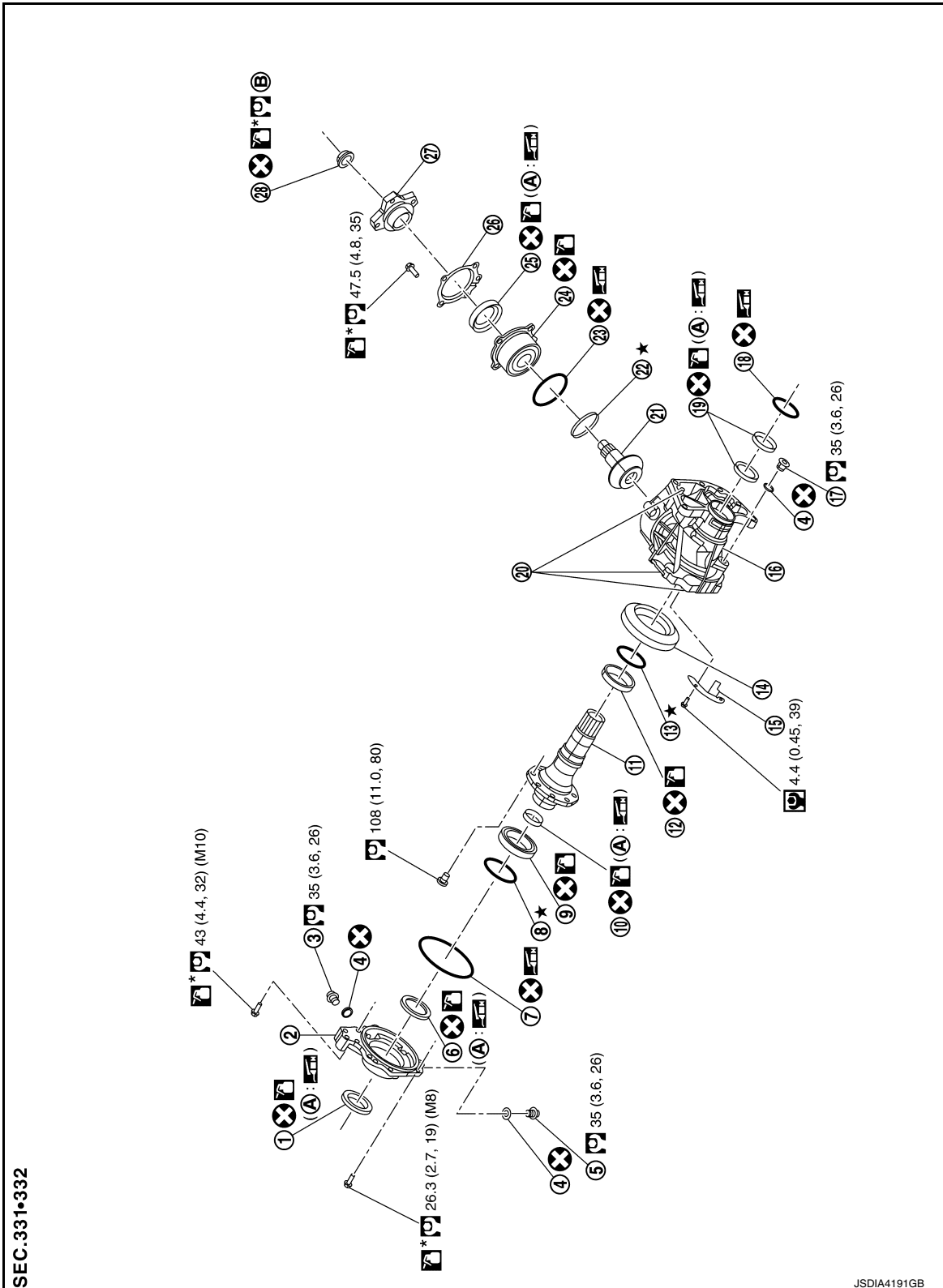

- | | | |
|------------|------------------|---------------|
| ① Oil seal | ② Transfer cover | ③ Filler plug |
| ④ Gasket | ⑤ Drain plug | ⑥ Oil seal |







RING GEAR SHAFT

< UNIT DISASSEMBLY AND ASSEMBLY >

[TRANSFER: TY21C]

- | | | | |
|---|---|---|---|
| ⑦ O-ring | ⑧ Ring gear bearing adjusting shim (transfer cover side) | ⑨ Ring gear bearing (transfer cover side) | A |
| ⑩ Drive shaft oil seal | ⑪ Ring gear shaft | ⑫ Ring gear bearing (transfer case side) | B |
| ⑬ Ring gear bearing adjusting shim (transfer case side) | ⑭ Ring gear | ⑮ Baffle plate | B |
| ⑯ Transfer case | ⑰ Plug | ⑱ O-ring | C |
| ⑲ Oil seal | ⑳ Dowel pin | ㉑ Drive pinion | C |
| ㉒ Drive pinion adjusting shim | ㉓ O-ring | ㉔ Pinion bearing assembly | |
| ㉕ Oil seal | ㉖ Dust cover | ㉗ Companion flange | |
| ㉘ Pinion lock nut | | | |
| Ⓐ Oil seal lip | Ⓑ Comply with the assembly procedure when tightening. Refer to DLN-72 , "Disassembly and Assembly". | | |

DLN

- : N·m (kg-m, in-lb)
- : N·m (kg-m, ft-lb)
- : Always replace after every disassembly.
- : Apply gear oil.
- : Apply anti-corrosive oil.
- : Apply multi-purpose grease.
- ★: Select with proper thickness.

E
F
G
H

Disassembly and Assembly

INFOID:000000012892921

DISASSEMBLY

1. Remove transfer cover assembly. Refer to [DLN-63](#), "Disassembly and Assembly".
2. Remove ring gear bearing outer race (transfer cover side) and ring gear bearing adjusting shim (transfer cover side) from the transfer cover. Refer to [DLN-63](#), "Disassembly and Assembly".
3. Remove ring gear shaft assembly from the transfer case.
4. Remove ring gear bearing outer race (transfer case side) and ring gear bearing adjusting shim (transfer case side) from the transfer case. Refer to [DLN-80](#), "Disassembly and Assembly".
5. Remove ring gear bearing inner race (transfer cover side) from ring gear shaft with drift (A) (commercial service tool) and replacer (commercial service tool).

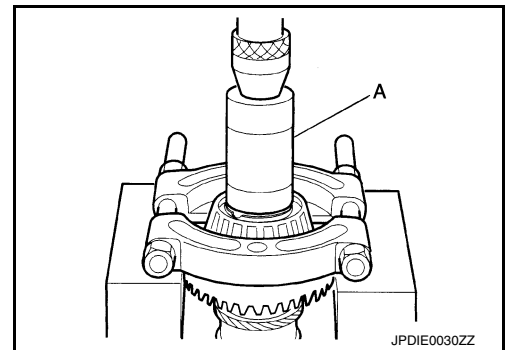

I
J
K
L
M
N
O
P

RING GEAR SHAFT

< UNIT DISASSEMBLY AND ASSEMBLY >

[TRANSFER: TY21C]

- Remove ring gear bearing inner race (transfer case side) from ring gear shaft with the drift (A) [SST: ST33061000 (J-8107-2)] and puller (commercial service tool).
- Remove the ring gear mounting bolts.

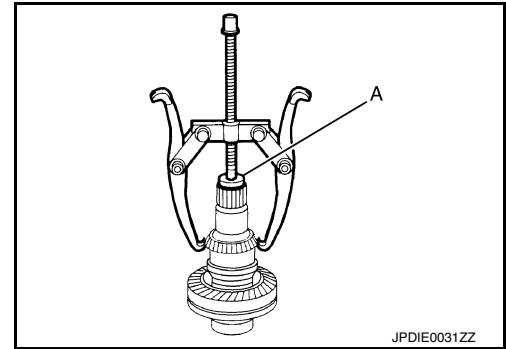

- Lightly tap ring gear with a plastic hammer to remove ring gear from the ring gear shaft.

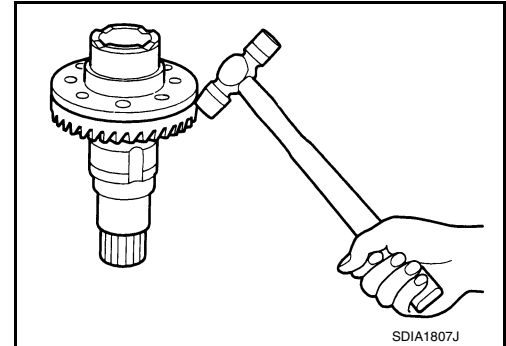

- Remove drive shaft oil seal from the ring gear shaft with the puller (A) [SST: KV381054S0 (J-34286)].
- Perform inspection after disassembly. Refer to [DLN-69. "Inspection"](#).

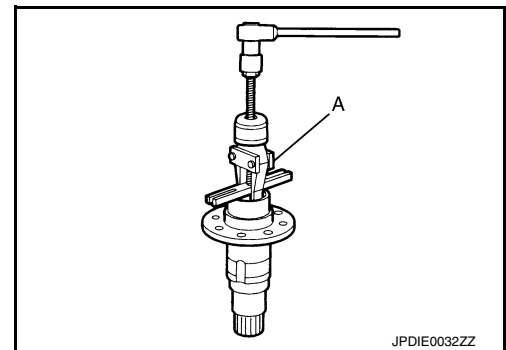

ASSEMBLY

- Using drift (A) (commercial service tool), install drive shaft oil seal ① within the dimension (L) shown as follows.

$$L : 2.0 +0.6/-0 \text{ mm } (0.079 +0.024/-0 \text{ in})$$

CAUTION:

- Never reuse the oil seal.
- When installing, never incline oil seal.
- Apply multi-purpose grease onto oil seal lips, and gear oil onto the circumference of the oil seal.

- Select ring gear bearing adjusting shim (transfer case side) and ring gear bearing adjusting shim (transfer cover side). Refer to [DLN-74. "Adjustment"](#).

- Assemble the selected ring gear bearing adjusting shim (transfer case side) and ring gear bearing outer race (transfer case side) to transfer case. Refer to [DLN-80. "Disassembly and Assembly"](#).

CAUTION:

- Never reuse ring gear bearing.
- Apply gear oil to the ring gear bearing.

- Assemble the selected ring gear bearing adjusting shim (transfer cover side) and ring gear bearing outer race (transfer cover side) to transfer cover. Refer to [DLN-63. "Disassembly and Assembly"](#).

CAUTION:

- Never reuse ring gear bearing.
- Apply gear oil to the ring gear bearing.

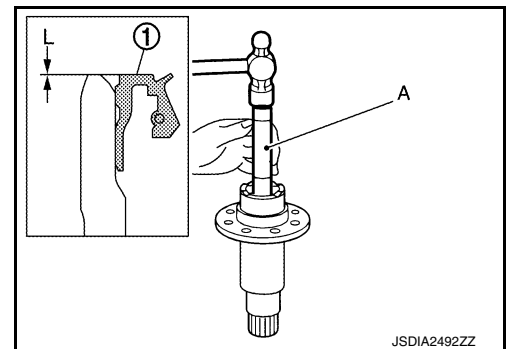

RING GEAR SHAFT

< UNIT DISASSEMBLY AND ASSEMBLY >

[TRANSFER: TY21C]

5. Install the ring gear to ring gear shaft, and tighten mounting bolts to the specified torque.
6. Install ring gear bearing inner race (transfer cover side) with drift (A) (commercial service tool).

CAUTION:

- Never reuse ring gear bearing.
- Apply gear oil to the ring gear bearing.

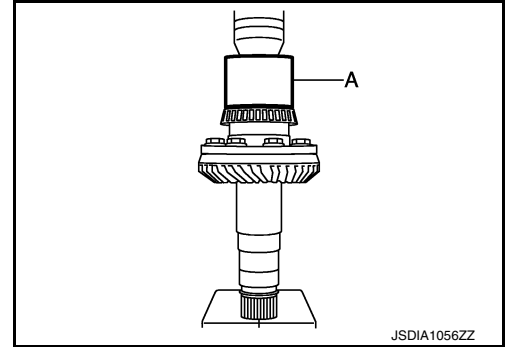

7. Install the ring gear bearing inner race (transfer case side) to ring gear shaft with drift (A) (commercial service tool).

CAUTION:

- Never reuse ring gear bearing.
- Apply gear oil to the ring gear bearing.

8. Install the ring gear shaft assembly to the transfer case.

CAUTION:

Protect transfer case oil seals beforehand from being damaged by the spline of ring gear shaft below method following.

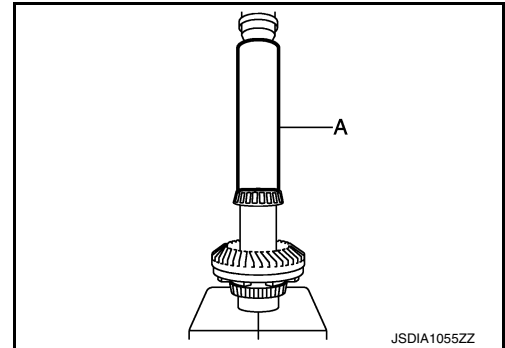

- a. Apply multi-purpose grease to spline part indicated in the figure.

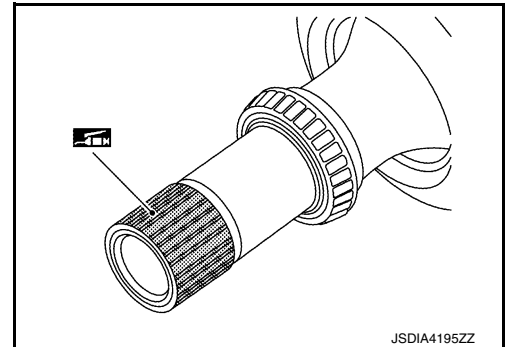

- b. Wrap piece of vinyl to spline part only indicated in the figure. (A): limit line)

CAUTION:

Never wrap sliding surfaces on oil seal.

9. Install transfer cover to check and adjust each part. Refer to [DLN-63, "Disassembly and Assembly"](#).

NOTE:

At this timing, O-ring installing to transfer cover is not necessary. Install O-ring after backlash and tooth contact are checked.

10. Check backlash, tooth contact, total preload and companion flange runout. Refer to [DLN-74, "Adjustment"](#).

CAUTION:

Measure the total preload without oil seals of transfer cover and transfer case.

11. Reinstall transfer cover for installing O-ring. Refer to [DLN-63, "Disassembly and Assembly"](#).

12. After installing transfer case oil seals, remove wrapped vinyl from the spline of ring gear shaft.

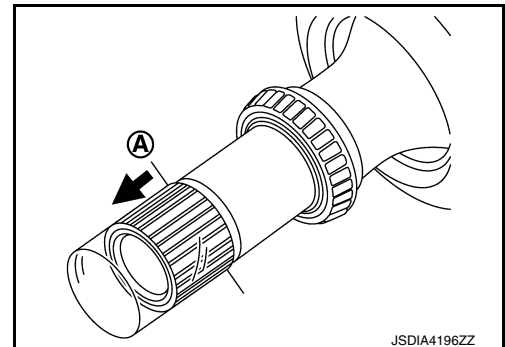

Inspection

INFOID:000000012892922

INSPECTION AFTER DISASSEMBLY

Check items below. If necessary, replace them with new ones.

Gear and Shaft

RING GEAR SHAFT

< UNIT DISASSEMBLY AND ASSEMBLY >

[TRANSFER: TY21C]

Check gear face and shaft for wear, cracks, damage, and seizure.

CAUTION:

If malfunction is detected on the ring gear or drive pinion, replace the ring gear and drive pinion as a set.

Bearing

Check for seizure, peeling, wear, corrosion, sticking, unusual noise, roughness in hand turning, and other damage.

CAUTION:

When replacing the bearing, always replace the inner race and outer race as a pair.

Shim

Check for seizure, damage, and unusual wear.

DRIVE PINION

< UNIT DISASSEMBLY AND ASSEMBLY >

[TRANSFER: TY21C]

DRIVE PINION

Exploded View

INFOID:000000012892923

A
B
C
DLN
E
F
G
H
I
J
K
L
M
N
O
P

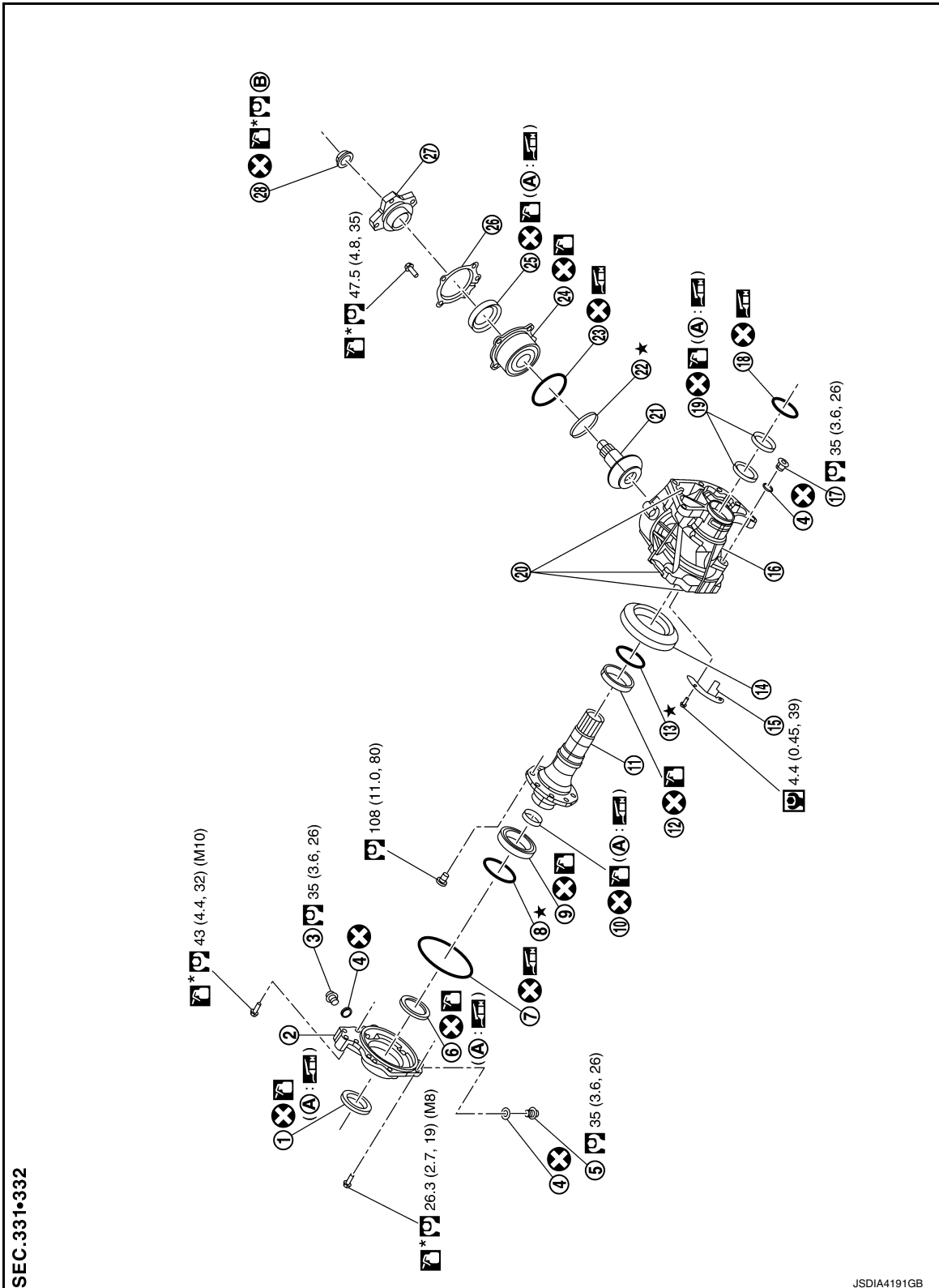

- | | | |
|------------|------------------|---------------|
| ① Oil seal | ② Transfer cover | ③ Filler plug |
| ④ Gasket | ⑤ Drain plug | ⑥ Oil seal |

DRIVE PINION

< UNIT DISASSEMBLY AND ASSEMBLY >

[TRANSFER: TY21C]

- | | | |
|---|---|---|
| ⑦ O-ring | ⑧ Ring gear bearing adjusting shim (transfer cover side) | ⑨ Ring gear bearing (transfer cover side) |
| ⑩ Drive shaft oil seal | ⑪ Ring gear shaft | ⑫ Ring gear bearing (transfer case side) |
| ⑬ Ring gear bearing adjusting shim (transfer case side) | ⑭ Ring gear | ⑮ Baffle plate |
| ⑯ Transfer case | ⑰ Plug | ⑱ O-ring |
| ⑲ Oil seal | ⑳ Dowel pin | ㉑ Drive pinion |
| ㉒ Drive pinion adjusting shim | ㉓ O-ring | ㉔ Pinion bearing assembly |
| ㉕ Oil seal | ㉖ Dust cover | ㉗ Companion flange |
| ㉘ Pinion lock nut | | |
| Ⓐ Oil seal lip | Ⓑ Comply with the assembly procedure when tightening. Refer to DLN-72 , "Disassembly and Assembly". | |

: N·m (kg-m, in-lb)

: N·m (kg-m, ft-lb)

: Always replace after every disassembly.

: Apply gear oil.

: Apply anti-corrosive oil.

: Apply multi-purpose grease.

★: Select with proper thickness.

Disassembly and Assembly

INFOID:000000012892924

DISASSEMBLY

1. Remove pinion bearing assembly mounting bolts.

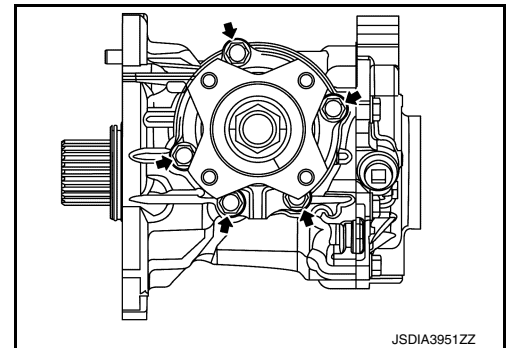

2. Lightly tap companion flange with a plastic hammer to remove drive pinion assembly ①.
3. Remove the O-ring from pinion bearing.
4. Remove the pinion lock nut.

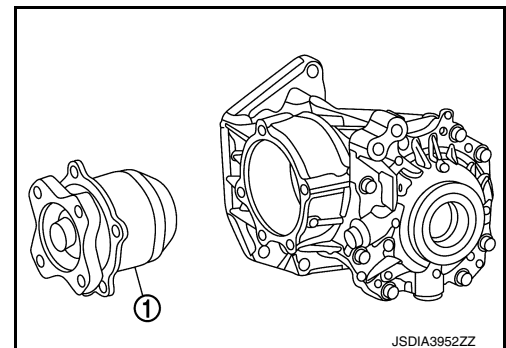

DRIVE PINION

< UNIT DISASSEMBLY AND ASSEMBLY >

[TRANSFER: TY21C]

- Remove drive pinion from pinion bearing assembly with drift (A) (commercial service tool) and replacer (B) (commercial service tool).
- Remove adjusting shim.
- Remove companion flange.
- Remove the dust cover.
- Remove the oil seal.
- Perform inspection after disassembly. Refer to [DLN-78, "Inspection"](#).

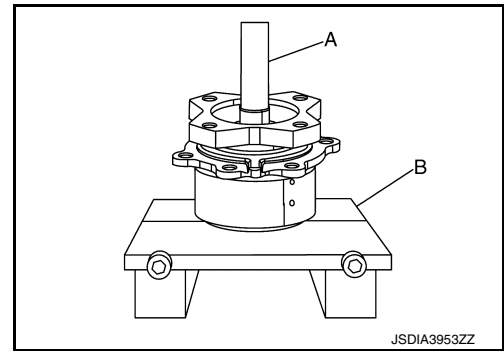

ASSEMBLY

- Select drive pinion adjusting shim. Refer to [DLN-74, "Adjustment"](#).
- Assemble the selected drive pinion adjusting shim to drive pinion.
- Install the drive pinion to pinion bearing assembly with drift (commercial service tool).

CAUTION:

- Never reuse pinion bearing assembly.
- Apply gear oil to pinion bearing part.

- Install oil seal to pinion bearing assembly with drift (A) (commercial service tool).

CAUTION:

- Never reuse the oil seal.
- When installing, never incline oil seal.
- Apply multi-purpose grease onto oil seal lips, and gear oil onto the circumference of the oil seal.

- Install dust cover.

NOTE:

Tighten dust cover together with pinion bearing assembly.

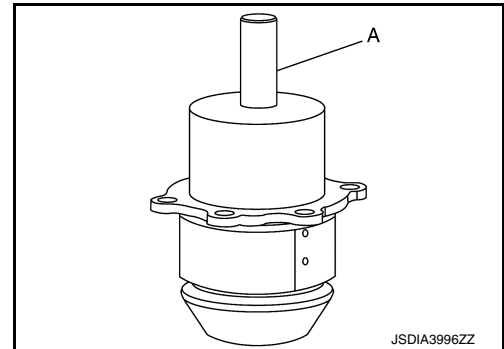

- Install companion flange ① to pinion bearing with drift (A) (commercial service tool).
- Apply anti-corrosive oil to the thread and seat of the lock nut, and adjust the pinion lock nut tightening torque and pinion bearing preload torque, using a preload gauge.
- Install pinion lock nut, and then tighten to the specified torque.

Pinion lock nut tightening torque : $90 \pm 9 \text{ N}\cdot\text{m}$ ($9.2 \pm 0.92 \text{ kg}\cdot\text{m}$, $66 \pm 7 \text{ ft}\cdot\text{lb}$)

CAUTION:

- Never reuse pinion lock nut.
- Check that pinion lock nut is seated on the companion flange.

- After tightening pinion lock nut to the specified torque, retighten the pinion lock nut by 25 degrees.
- Measure the pinion bearing preload.

Pinion bearing preload : Refer to [DLN-83, "Preload Torque"](#).

- Apply multi-purpose grease lightly and evenly onto an O-ring, and install it to the pinion bearing assembly.

CAUTION:

- Never reuse O-ring.
- When installing O-ring, never use a tool.
- Never damage O-ring.

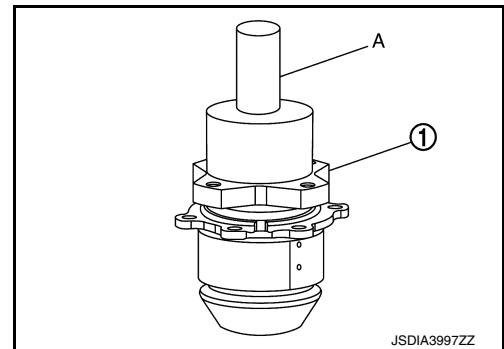

DRIVE PINION

< UNIT DISASSEMBLY AND ASSEMBLY >

[TRANSFER: TY21C]

- Install drive pinion assembly, and apply anti-corrosive oil onto thread and seats on the mounting bolts. Tighten to the specified torque.

NOTE:

Tighten dust cover together with pinion bearing assembly.

- Check backlash, tooth contact, total preload and companion flange runout. Refer to [DLN-74, "Adjustment"](#).

CAUTION:

Measure the total preload without oil seals of transfer cover and transfer case.

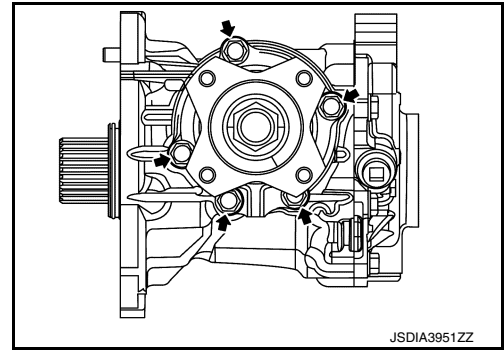

JSDIA3951ZZ

Adjustment

INFOID:000000012892925

ADJUSTING SHIM SELECTION

Measurement point

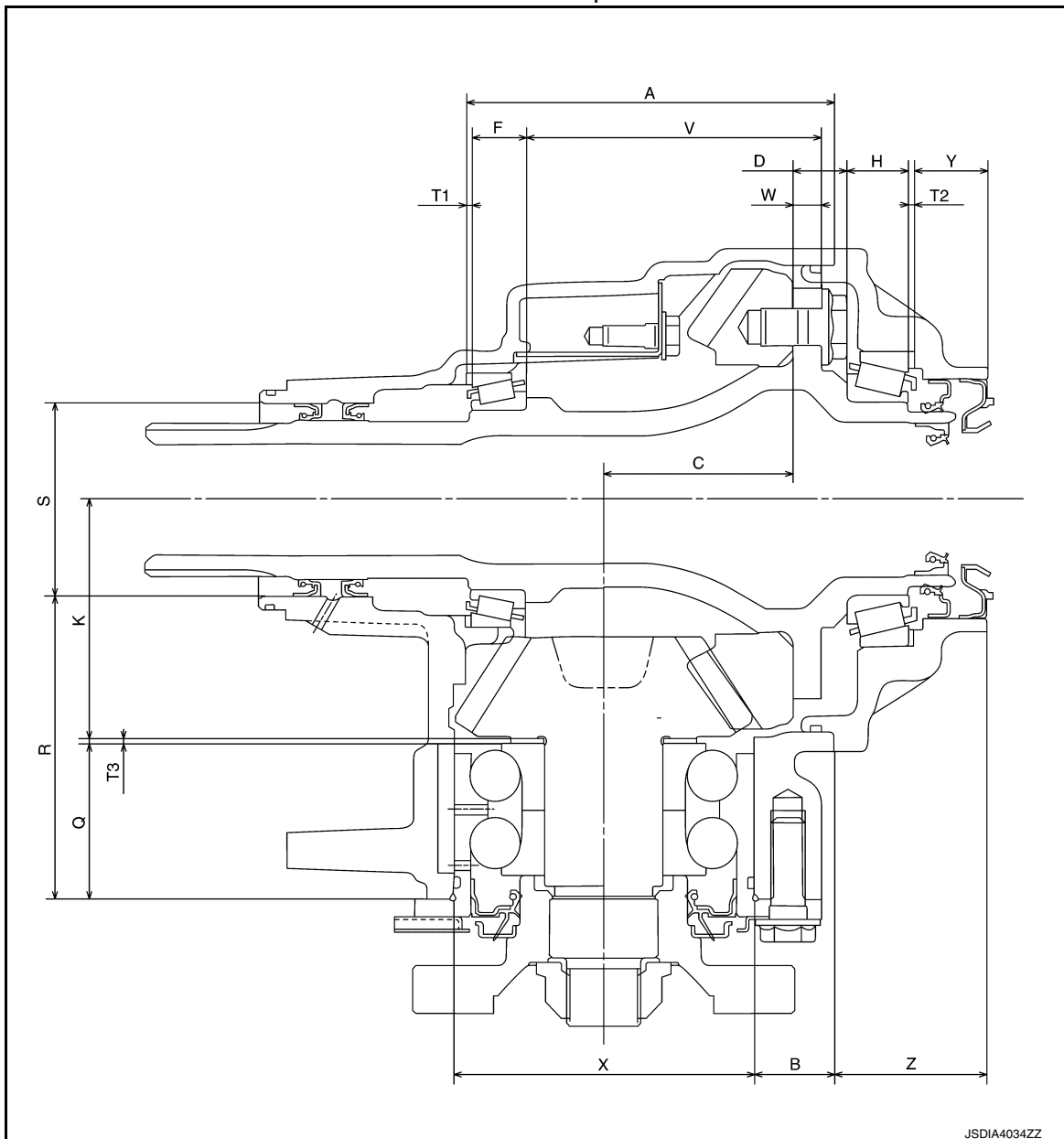

JSDIA4034ZZ

Select adjusting shim of T1, T2, and T3, respectively, by using the following equation.

T1 [Ring gear bearing adjusting shim (transfer case side)]

$$\bullet T1 = A - (B + X/2) + C + W - V - F - (M/100) + 0.071 \text{ mm (0.0028 in)}$$

DRIVE PINION

< UNIT DISASSEMBLY AND ASSEMBLY >

[TRANSFER: TY21C]

T2 [Ring gear bearing adjusting shim (transfer cover side)]

$$\bullet T2 = -Y + Z + (B + X/2) - C - D - H + (M/100) + 0.071 \text{ mm (0.0028 in)}$$

T3 (Drive pinion adjusting shim)

$$\bullet T3 = -Q + (R + S/2) - K + (O/100)$$

- Check dimension (M) on the ring gear side face.

NOTE:

Dimension "M" indicates the difference between the optimum engagement and standard dimensions in increments of 0.01 mm (0.0004 in) written on the ring gear side face.

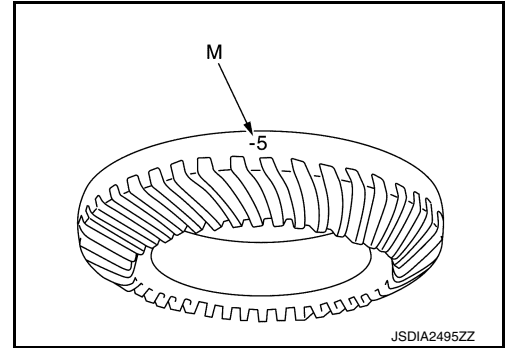

- Check dimension (O) on the gear end of drive pinion.

NOTE:

Dimension "O" indicates the difference between the optimum engagement and the standard dimensions in increments of 0.01 mm (0.0004 in) written on the gear end of drive pinion.

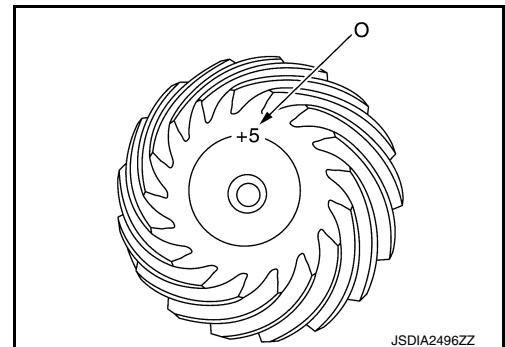

PINION BEARING PRELOAD

CAUTION:

When measuring preload, the rotating speed must be set to 30 rpm.

1. Remove ring gear shaft assembly from the transfer case. Refer to [DLN-67, "Disassembly and Assembly"](#).
2. Rotate the companion flange back and forth from 2 to 3 times to check for unusual noise, binding, sticking, and so on.
3. Rotate the companion flange at least 20 times to check for smooth operation of the bearing.
4. Measure the pinion bearing preload with the preload gauge (A) [SST: ST3127S000 (J-25765-A)].

Pinion bearing preload : Refer to [DLN-83, "Preload Torque"](#).

CAUTION:

Each rotational part should rotate smoothly with the specified gear oil.

- If outside the standard, disassemble the drive pinion assembly to check and adjust each part.

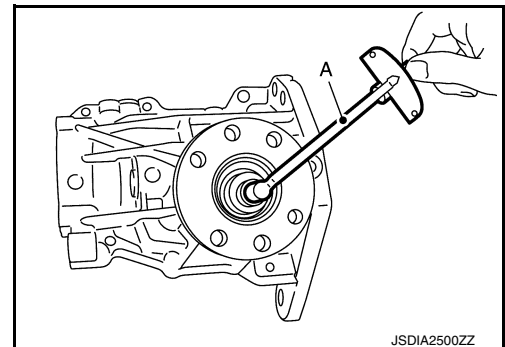

TOTAL PRELOAD

CAUTION:

When measuring preload, the rotating speed must be set to 30 rpm.

1. Measure pinion bearing preload.
CAUTION:
Check that the pinion bearing preload is within the standard.
2. Assemble the ring gear shaft assembly to the transfer case. Refer to [DLN-67, "Disassembly and Assembly"](#)
3. Install transfer cover to check and adjust each part. Refer to [DLN-63, "Disassembly and Assembly"](#).
4. Rotate the companion flange at least 20 times to check for smooth operation of the bearing.

A
B
C
DLN
E
F
G
H
I
J
K
L
M
N
O
P

DRIVE PINION

< UNIT DISASSEMBLY AND ASSEMBLY >

[TRANSFER: TY21C]

5. Measure the total preload with the preload gauge (A) [SST: ST3127S000 (J-25765-A)].

Total preload : Refer to [DLN-83, "Preload Torque"](#).

CAUTION:

Each rotational part should rotate smoothly with the specified gear oil.

- If outside the standard, disassemble the transfer assembly to check and adjust each part. Measure it with the transfer case oil seal and transfer cover oil seal removed when measuring total preload after disassembly. Then install transfer case oil seals and transfer cover oil seal.

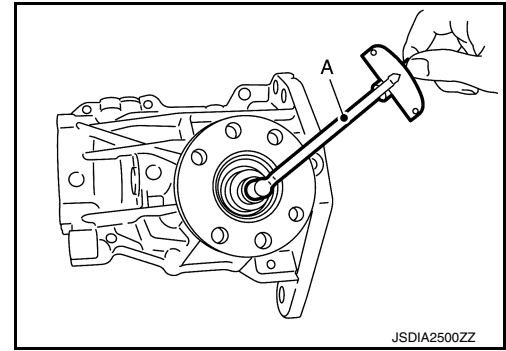

BACKLASH

1. Install the bolt to the companion flange.
2. Fit a dial indicator onto the bolt (A).
3. Measure the circumference backlash of the companion flange.

Backlash : Refer to [DLN-83, "Backlash"](#).

- If outside the standard, disassemble the transfer assembly to check and adjust each part.

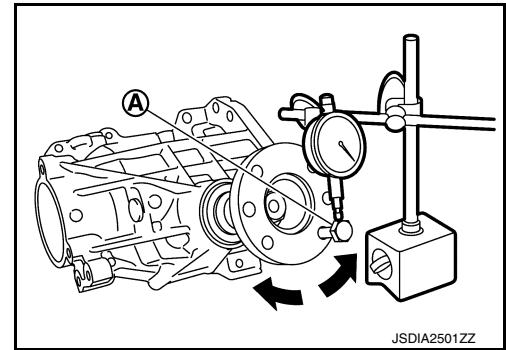

TOOTH CONTACT

1. Remove transfer cover. Refer to [DLN-63, "Disassembly and Assembly"](#).
2. Remove ring gear shaft assembly from transfer case. Refer to [DLN-67, "Disassembly and Assembly"](#).
3. Apply red lead onto the ring gear.

CAUTION:

Apply red lead to both faces of 3 to 4 gears at 4 locations evenly spaced on the ring gear.

4. Assemble the ring gear shaft assembly to the transfer case. Refer to [DLN-67, "Disassembly and Assembly"](#).
5. Install transfer cover to check and adjust each part. Refer to [DLN-63, "Disassembly and Assembly"](#).

NOTE:

At this timing, O-ring installing to transfer cover is not necessary. Install O-ring after backlash and tooth contact are checked.

6. Remove the plug from the transfer case.
7. Rotate the companion flange back and forth several times, and check the drive pinion gear to ring gear tooth contact by viewing from the plug hole.

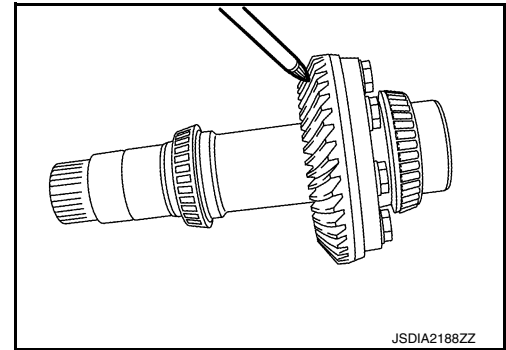

DRIVE PINION

< UNIT DISASSEMBLY AND ASSEMBLY >

[TRANSFER: TY21C]

Tooth Contact Judgment Guide

Drive pinion adjusting shim selection value mm(in)		Tooth contact condition				Need for adjustment
		Drive side		Back side		
↑ Thinner	-0.09 (-0.0035)	Heel side 	Toe side 	Toe side 	Heel side 	YES
	-0.06 (-0.0024)					
	-0.03 (-0.0012)					NO
	0					
↓ Thicker	+0.03 (+0.0012)					YES
	+0.06 (+0.0024)					
	+0.09 (+0.0035)					

JSDIA4035GB

8. Follow the procedure below to adjust pinion height (dimension X) if tooth contact is improper. For selecting adjusting shim, refer to the latest parts information.

CAUTION:

If no adjusting shim with the calculated value is available, select the thicker and closest one.

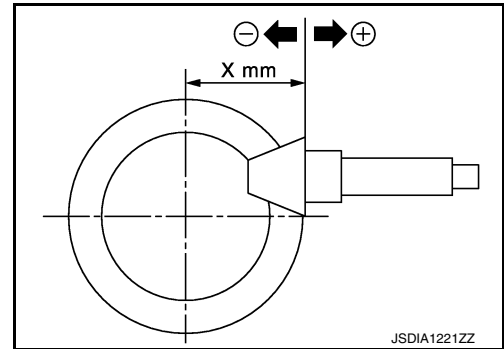

JSDIA1221ZZ

- Thicken the drive pinion adjusting shim to move the drive pinion closer to the ring gear in case of face contact or heel contact.

CAUTION:

Only one adjusting shim can be selected.

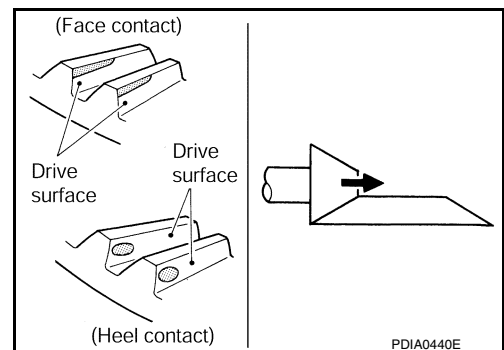

PDIA0440E

A
B
C
DLN
E
F
G
H
I
J
K
L
M
N
O
P

DRIVE PINION

< UNIT DISASSEMBLY AND ASSEMBLY >

[TRANSFER: TY21C]

- Thin the drive pinion adjusting shim to move the drive pinion farther from the ring gear in case of flank contact or toe contact.

CAUTION:

Only one adjusting shim can be selected.

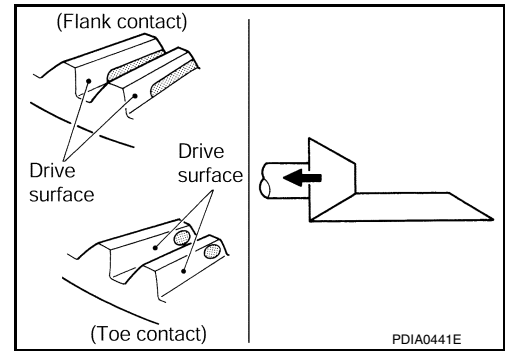

COMPANION FLANGE RUNOUT

- Fit a dial indicator onto the companion flange face (inner side of the propeller shaft mounting bolt holes).
- Rotate the companion flange to check for runout.

Companion flange runout : Refer to [DLN-83, "Companion Flange Runout"](#).

- Fit a test indicator to the inner side of the companion flange (socket diameter).
- Rotate the companion flange to check for runout.

Companion flange runout : Refer to [DLN-83, "Companion Flange Runout"](#).

- Follow the procedure below to adjust if runout value is outside the repair limit.
 - Check for runout while changing the phase between companion flange and drive pinion in 90° steps. Then search for the minimum point.
 - Replace companion flange if runout value is still outside the limit after the phase has been changed.
 - Adjust assembly status of the pinion bearing and drive pinion, or replace pinion bearing assembly if runout is outside the standard after the companion flange is replaced.

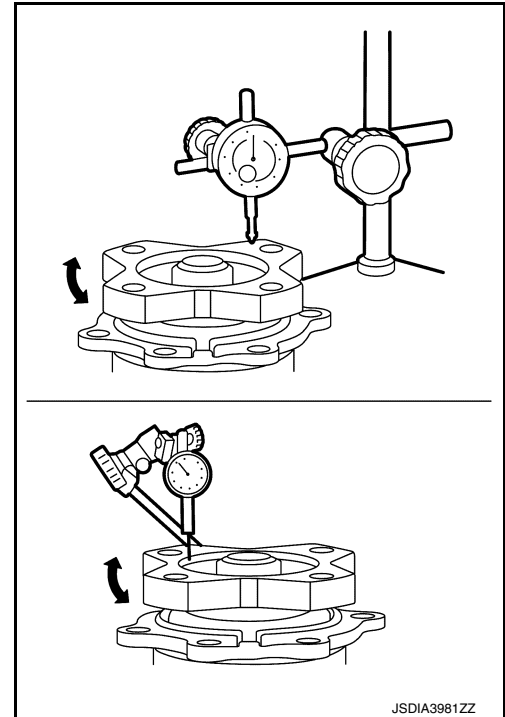

Inspection

INFOID:000000012892926

INSPECTION AFTER DISASSEMBLY

Check items below. If necessary, replace them with new ones.

Gear and Shaft

Check gear face and shaft for wear, cracks, damage, and seizure.

CAUTION:

Replace ring gear and drive pinion as a set (hypoid gear set) if any malfunction is detected on the ring gear or drive pinion.

Bearing

Check for seizure, peeling, wear, corrosion, sticking, unusual noise, roughness in hand turning, and other damage.

Shim

Check for seizure, damage, and unusual wear.

TRANSFER CASE

< UNIT DISASSEMBLY AND ASSEMBLY >

[TRANSFER: TY21C]

TRANSFER CASE

Exploded View

INFOID:000000012892927

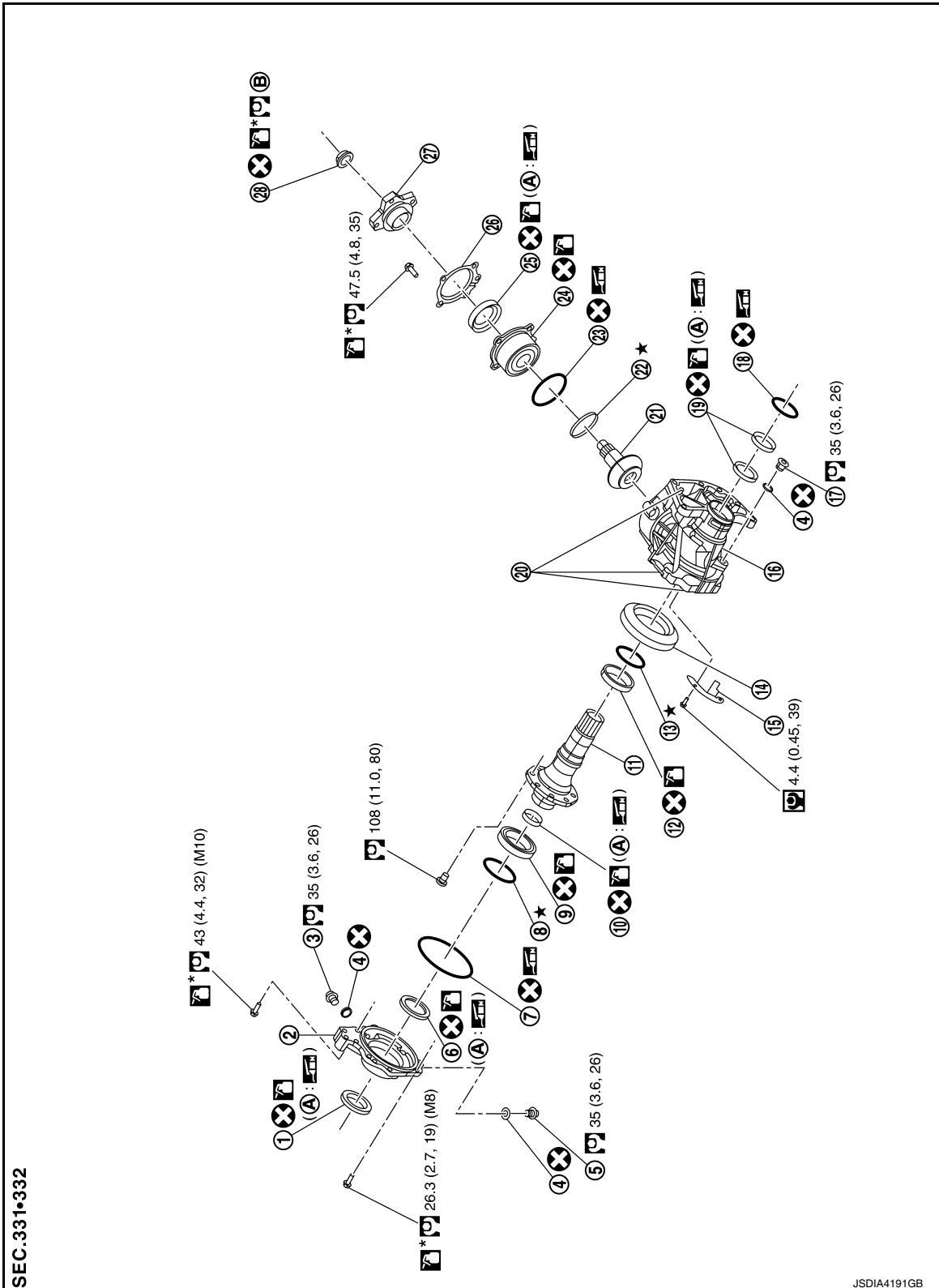

- | | | |
|------------|------------------|---------------|
| ① Oil seal | ② Transfer cover | ③ Filler plug |
| ④ Gasket | ⑤ Drain plug | ⑥ Oil seal |

A
B
C
DLN
E
F
G
H
I
J
K
L
M
N
O
P

TRANSFER CASE

< UNIT DISASSEMBLY AND ASSEMBLY >

[TRANSFER: TY21C]

- | | | |
|---|---|---|
| ⑦ O-ring | ⑧ Ring gear bearing adjusting shim (transfer cover side) | ⑨ Ring gear bearing (transfer cover side) |
| ⑩ Drive shaft oil seal | ⑪ Ring gear shaft | ⑫ Ring gear bearing (transfer case side) |
| ⑬ Ring gear bearing adjusting shim (transfer case side) | ⑭ Ring gear | ⑮ Baffle plate |
| ⑯ Transfer case | ⑰ Plug | ⑱ O-ring |
| ⑲ Oil seal | ⑳ Dowel pin | ㉑ Drive pinion |
| ㉒ Drive pinion adjusting shim | ㉓ O-ring | ㉔ Pinion bearing assembly |
| ㉕ Oil seal | ㉖ Dust cover | ㉗ Companion flange |
| ㉘ Pinion lock nut | | |
| Ⓐ Oil seal lip | Ⓑ Comply with the assembly procedure when tightening. Refer to DLN-72, "Disassembly and Assembly" . | |

: N·m (kg-m, in-lb)

: N·m (kg-m, ft-lb)

: Always replace after every disassembly.

: Apply gear oil.

: Apply anti-corrosive oil.

: Apply multi-purpose grease.

★: Select with proper thickness.

Disassembly and Assembly

INFOID:000000012892928

DISASSEMBLY

1. Remove transfer cover. Refer to [DLN-63, "Disassembly and Assembly"](#).
2. Remove ring gear shaft assembly. Refer to [DLN-67, "Disassembly and Assembly"](#).
3. Remove drive pinion assembly. Refer to [DLN-72, "Disassembly and Assembly"](#).
4. Remove O-ring from transfer case.
CAUTION:
 - Never use a tool.
 - Never damage transfer case.
5. Remove oil seals ①.
CAUTION:
Never damage transfer case.

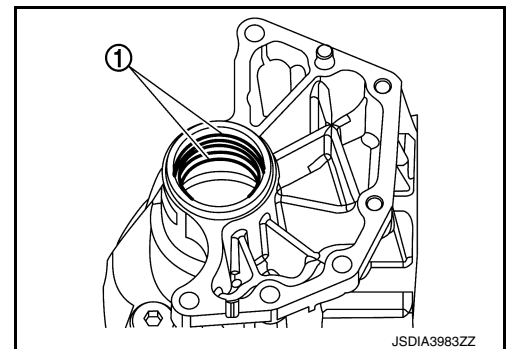

TRANSFER CASE

< UNIT DISASSEMBLY AND ASSEMBLY >

[TRANSFER: TY21C]

6. Remove baffle plate ①.

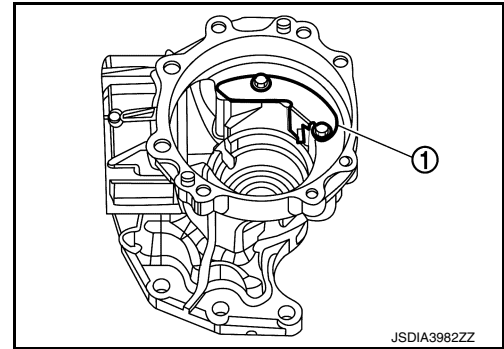

7. Remove the ring gear bearing adjusting shim (transfer case side) ① and ring gear bearing outer race (transfer case side) ② by tapping from the 2 cutouts (←) on the transfer case.

CAUTION:

Never damage transfer case.

8. Remove plug and gasket.
9. Perform inspection after disassembly. Refer to [DLN-82, "Inspection"](#).

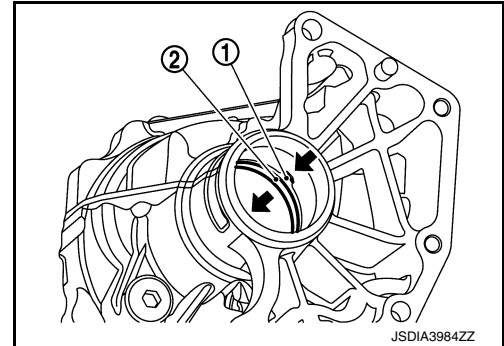

ASSEMBLY

1. Select the ring gear bearing adjusting shim (transfer case side). Refer to [DLN-74, "Adjustment"](#).

2. Install the selected ring gear bearing adjusting shim (transfer case side) and ring gear bearing outer race (transfer case side) using drift (A) (commercial service tool).

CAUTION:

- Never reuse ring gear bearing.
- Apply gear oil to the ring gear bearing.

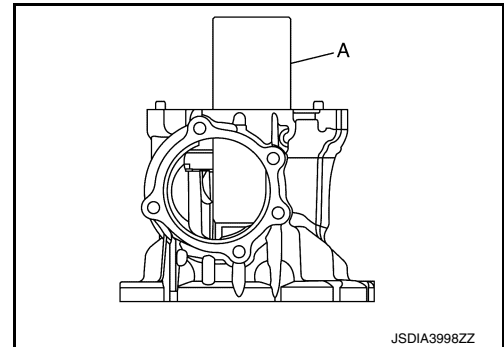

3. Install baffle plate ①.
4. Install ring gear shaft assembly. Refer to [DLN-67, "Disassembly and Assembly"](#).

CAUTION:

Protect transfer case oil seals beforehand from being damaged by the spline of ring gear shaft.

5. Install drive pinion assembly. Refer to [DLN-72, "Disassembly and Assembly"](#).
6. Install transfer cover to check and adjust each part. Refer to [DLN-63, "Disassembly and Assembly"](#).

NOTE:

At this timing, O-ring installing to transfer cover is not necessary. Install O-ring after backlash and tooth contact are checked.

7. Check backlash, tooth contact, total preload and companion flange runout. Refer to [DLN-74, "Adjustment"](#).

CAUTION:

Measure the total preload without oil seals of transfer cover and transfer case.

8. Reinstall transfer cover for installing O-ring. Refer to [DLN-63, "Disassembly and Assembly"](#).

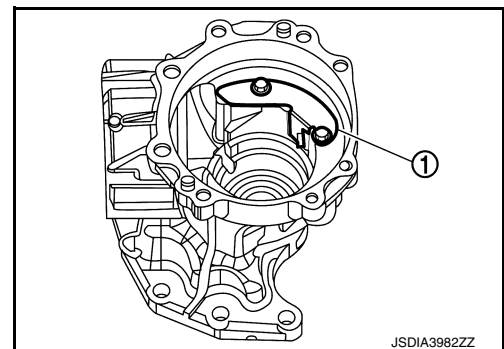

TRANSFER CASE

< UNIT DISASSEMBLY AND ASSEMBLY >

[TRANSFER: TY21C]

9. Install oil seals with drift (commercial service tool).

A : 24.8 mm (0.976 in)

B : 10.3 mm (0.406 in)

CAUTION:

- When checking the total preload torque, measure it without the oil seal, then install the oil seal.
- Never reuse the oil seal.
- When installing, never incline oil seal.
- Apply multi-purpose grease onto oil seal lips, and gear oil onto the circumference of the oil seal.
- Never damage oil seals by spline of ring gear shaft.

10. After installing oil seals to transfer case, remove wrapped vinyl from the spline of ring gear shaft.

11. Apply multi-purpose grease lightly and evenly onto an O-ring, and install it to the transfer case.

CAUTION:

- Never reuse O-ring.
- When installing O-ring, never use a tool.
- Never damage O-ring.

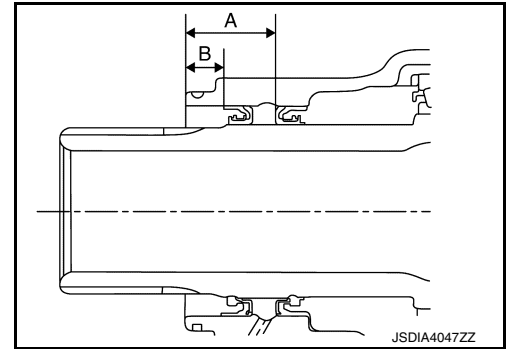

Inspection

INFOID:0000000012892929

INSPECTION AFTER DISASSEMBLY

Check items below. If necessary, replace them with new ones.

Case

Check the bearing mounting surface for wear, cracks and damages.

SERVICE DATA AND SPECIFICATIONS (SDS)

< SERVICE DATA AND SPECIFICATIONS (SDS)

[TRANSFER: TY21C]

SERVICE DATA AND SPECIFICATIONS (SDS)

SERVICE DATA AND SPECIFICATIONS (SDS)

General Specifications

INFOID:0000000012892930

Applied model	Axle	AWD
	Engine	VQ35DE
	Transaxle	CVT
Transfer model		TY21C
Gear ratio		0.404
Number of teeth	Ring gear	42
	Drive pinion	17
Oil capacity		Refer to MA-12, "Fluids and Lubricants" .

Preload Torque

INFOID:0000000012892931

Unit: N·m (kg·m, in·lb)

Item		Standard
Pinion bearing preload (P1)		0.25 – 1.15 (0.03 – 0.11, 3.0 – 10.0)
Total preload	With all oil seals	P1 + 0.7 – 1.0 (0.08 – 0.1, 7.0 – 8.0)
	Without oil seals (for transfer cover and transfer case)	P1 + 0.5 – 0.8 (0.06 – 0.08, 5.0 – 7.0)

Backlash

INFOID:0000000012892932

Unit: mm (in)

Item	Standard
Ring gear to drive pinion	0.16 – 0.21 (0.0063 – 0.0083)

Companion Flange Runout

INFOID:0000000012892933

Unit: mm (in)

Item	Standard
Companion flange face runout	0.15 (0.0059) or less
Inner side of the companion flange runout	0.1 (0.004) or less

PRECAUTIONS

< PRECAUTION >

[REAR PROPELLER SHAFT: C-CVJ-C]

PRECAUTION

PRECAUTIONS

Precaution for Supplemental Restraint System (SRS) "AIR BAG" and "SEAT BELT PRE-TENSIONER"

INFOID:000000013460080

The Supplemental Restraint System such as "AIR BAG" and "SEAT BELT PRE-TENSIONER", used along with a front seat belt, helps to reduce the risk or severity of injury to the driver and front passenger for certain types of collision. Information necessary to service the system safely is included in the SR and SB section of this Service Manual.

WARNING:

- To avoid rendering the SRS inoperative, which could increase the risk of personal injury or death in the event of a collision which would result in air bag inflation, it is recommended that all maintenance and repair be performed by an authorized NISSAN/INFINITI dealer.
- Improper repair, including incorrect removal and installation of the SRS, can lead to personal injury caused by unintentional activation of the system. For removal of Spiral Cable and Air Bag Module, see the SR section.
- Do not use electrical test equipment on any circuit related to the SRS unless instructed to in this Service Manual. SRS wiring harnesses can be identified by yellow and/or orange harnesses or harness connectors.

PRECAUTIONS WHEN USING POWER TOOLS (AIR OR ELECTRIC) AND HAMMERS

WARNING:

- When working near the Air Bag Diagnosis Sensor Unit or other Air Bag System sensors with the Ignition ON or engine running, DO NOT use air or electric power tools or strike near the sensor(s) with a hammer. Heavy vibration could activate the sensor(s) and deploy the air bag(s), possibly causing serious injury.
- When using air or electric power tools or hammers, always switch the Ignition OFF, disconnect the battery or batteries, and wait at least three minutes before performing any service.

Service Notice or Precautions for Propeller Shaft

INFOID:000000012892934

- Replace the propeller shaft assembly if there is a breakage or deflection on tube.
- Never hit the tube or apply an impact on it during repair service. Never damage the tube as well.
- The joint cannot be disassembled. Never disassemble it.
- If constant velocity joint was bent during propeller shaft assembly removal, installation, or transportation, its boot may be damaged. Wrap boot interference area to metal part with shop cloth or rubber to protect boot from breakage.

PREPARATION

< PREPARATION >

[REAR PROPELLER SHAFT: C-CVJ-C]

PREPARATION

PREPARATION

Commercial Service Tool

INFOID:000000012892935

Tool name	Description
Power tool  PIIB1407E	Loosening nuts, screws and bolts

A

B

C

DLN

E

F

G

H

I

J

K

L

M

N

O

P

STRUCTURE AND OPERATION

< SYSTEM DESCRIPTION >

[REAR PROPELLER SHAFT: C-CVJ-C]

SYSTEM DESCRIPTION

STRUCTURE AND OPERATION

Sectional View

INFOID:0000000012892936

PART OF JOINT

Universal Type (Shell Type)

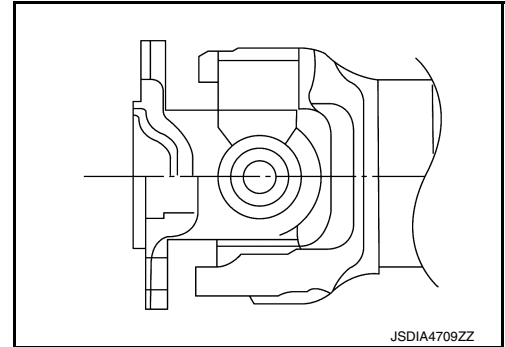

CVJ Type

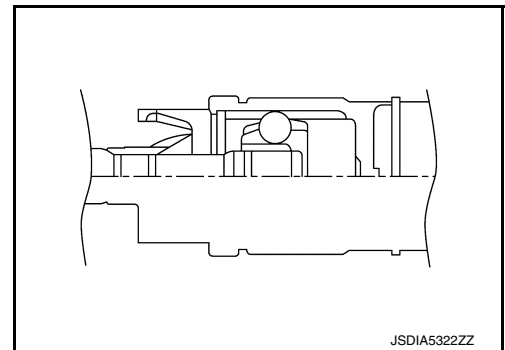

NOISE, VIBRATION AND HARSHNESS (NVH) TROUBLESHOOTING

< SYMPTOM DIAGNOSIS >

[REAR PROPELLER SHAFT: C-CVJ-C]

SYMPTOM DIAGNOSIS

NOISE, VIBRATION AND HARSHNESS (NVH) TROUBLESHOOTING

NVH Troubleshooting Chart

INFOID:0000000012892937

Use the chart below to find the cause of the symptom. If necessary, repair or replace these parts.

Symptom		Possible cause and SUSPECTED PARTS													
		Uneven rotating torque	Center bearing improper installation	Excessive center bearing axial end play	Center bearing mounting (insulator) cracks, damage or deterioration	Excessive joint angle	Rotation imbalance	Excessive runout	DIFFERENTIAL	AXLE AND SUSPENSION	TIRE	ROAD WHEEL	DRIVE SHAFT	BRAKE	STEERING
Noise	Noise	x	x	x	x	x	x	x	x	x	x	x	x	x	x
	Shake		x			x				x	x	x	x	x	x
	Vibration	x	x	x	x	x	x	x		x	x	x	x		x
Reference		DLN-88, "Inspection"	DLN-89, "Exploded View"	DLN-88, "Inspection"	DLN-92, "Inspection"	DLN-88, "Inspection"	DLN-88, "Inspection"	DLN-88, "Inspection"	NVH of REAR FINAL DRIVE in this section.	NVH in FAX, RAX, FSU, and RSU section.	NVH in WT section.	NVH in WT section.	NVH in FAX and RAX section.	NVH in BR section.	NVH in ST section.

x: Applicable

A
B
C
DLN
E
F
G
H
I
J
K
L
M
N
O
P

PERIODIC MAINTENANCE

REAR PROPELLER SHAFT

Inspection

INFOID:000000012892938

LOOSENESS OF CONNECTED PART

Check each fixing bolt and nut for looseness using torque wrench. For each tightening torque, refer to [DLN-89. "Exploded View"](#).

BACKLASH OF JOINT PART

Move the joint of propeller shaft up and down and from side to side (axial direction of shaft and right angle to shaft) to check that the joint has no backlash. If the joint has a malfunction, remove propeller shaft and perform inspection.

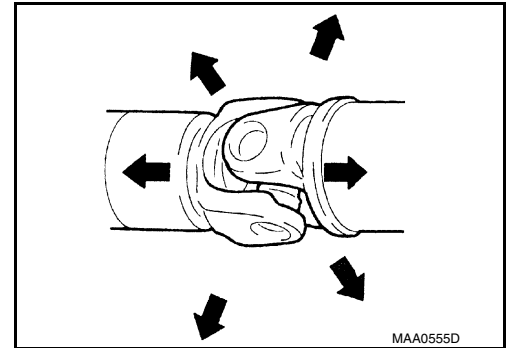

BACKLASH OF CENTER BEARING

Move the shaft near center bearing up and down and from side to side (axial direction of shaft and right angle to shaft) to check that the bearing has no backlash. If the bearing has a malfunction, remove propeller shaft and perform inspection.

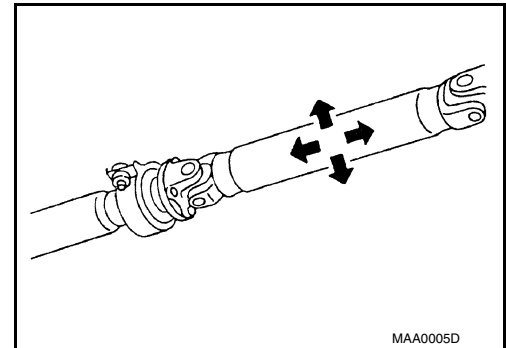

APPEARANCE AND NOISE

- Check the propeller shaft tube surface for dents or cracks. If malfunction is detected, replace propeller shaft assembly.
- If center bearing is noisy or damaged, replace propeller shaft assembly.

VIBRATION

If vibration is present at high speed, adjust the propeller shaft phase first.

1. Check the propeller shaft for bend and damage. If damaged, replace propeller shaft assembly.
2. Perform a cruise test drive to check the propeller shaft for runout. If vibration occurs, separate propeller shaft at final drive companion flange; then change the phase between electric controlled coupling stud bolt and propeller shaft by the one bolt hole at a time and install propeller shaft.
3. If vibration is still detected, measure propeller shaft runout after removing it. Refer to [DLN-92. "Inspection"](#).

REAR PROPELLER SHAFT

< REMOVAL AND INSTALLATION >

[REAR PROPELLER SHAFT: C-CVJ-C]

REMOVAL AND INSTALLATION

REAR PROPELLER SHAFT

Exploded View

INFOID:000000012892939

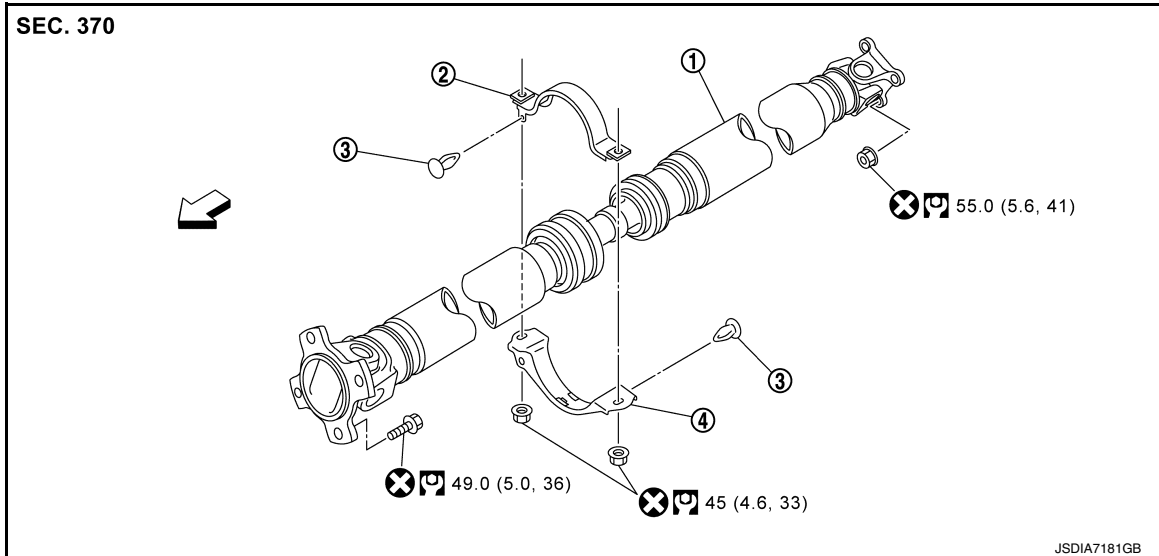

- ① Propeller shaft assembly
- ② Center bearing mounting bracket (upper)
- ③ Clip
- ④ Center bearing mounting bracket (lower)

⇐: Vehicle front

: N·m (kg-m, ft-lb)

: Always replace after every disassembly.

Removal and Installation

INFOID:000000012892940

REMOVAL

1. Shift transaxle to the neutral position and then release parking brake.
2. Remove front exhaust tube. Refer to [EX-5, "Exploded View"](#).
3. Remove heat insulator (1).

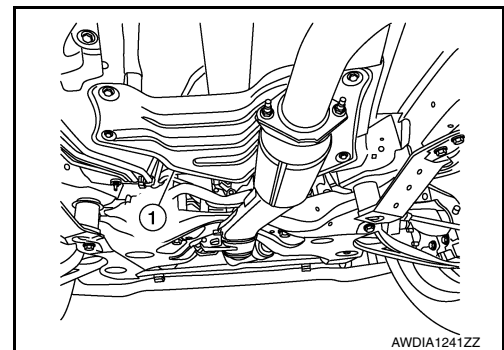

REAR PROPELLER SHAFT

< REMOVAL AND INSTALLATION >

[REAR PROPELLER SHAFT: C-CVJ-C]

4. Put matching marks (A) on propeller shaft flange yoke and transfer companion flange.

CAUTION:

For matching mark, use paint. Never damage propeller shaft flange yoke and transfer companion flange.

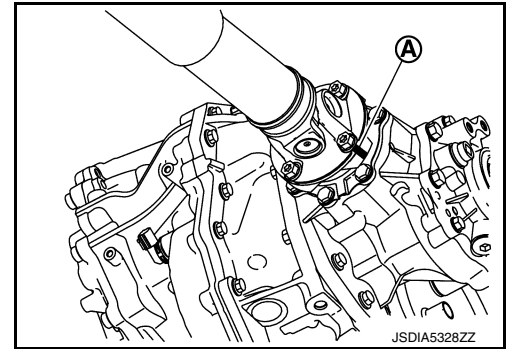

5. Put matching marks (A) on propeller shaft flange yoke and electric controlled coupling.

CAUTION:

- For matching mark, use paint. Never damage propeller shaft flange yoke and electric controlled coupling.
- If the tip of stud bolt of electric controlled coupling has a paint mark, place a matching mark for identification of the position of applicable stud bolt.

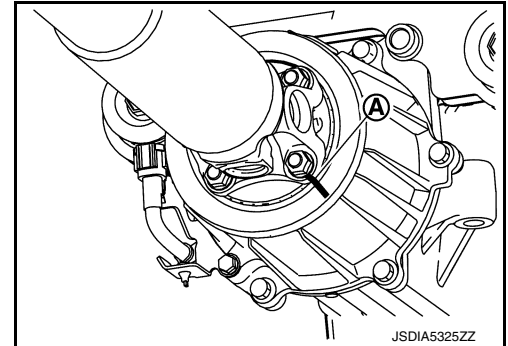

6. Loosen mounting nuts (A) of center bearing mounting bracket.

NOTE:

Tighten mounting nuts (A) temporarily to prevent drop of propeller shaft.

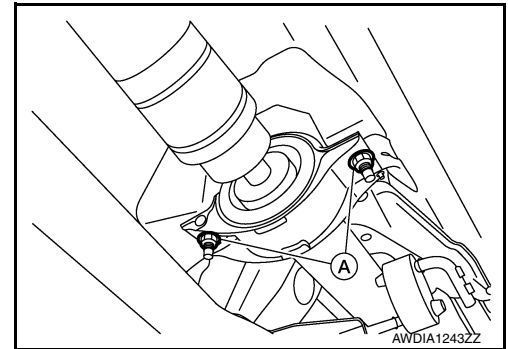

7. Remove propeller shaft assembly fixing bolts (A), and separate propeller shaft assembly from transfer companion flange.

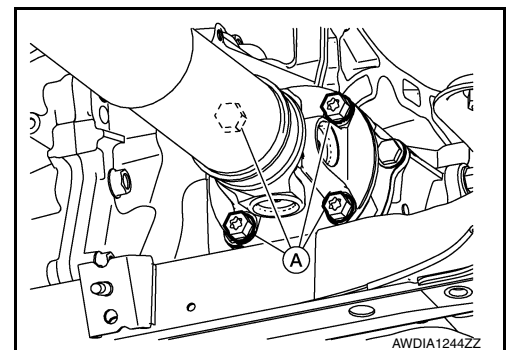

8. Remove propeller shaft assembly fixing nuts (A), and separate propeller shaft assembly from electric controlled coupling (1) of final drive.

9. Remove center bearing mounting bracket mounting nuts.

10. Remove propeller shaft assembly.

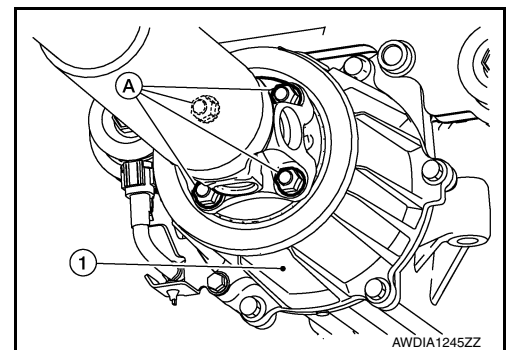

REAR PROPELLER SHAFT

< REMOVAL AND INSTALLATION >

[REAR PROPELLER SHAFT: C-CVJ-C]

11. Remove clips and then remove center bearing mounting bracket (upper/lower).

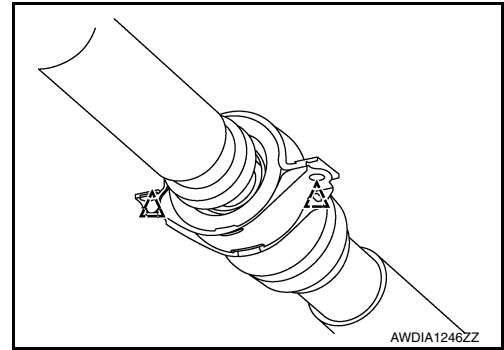

12. Perform inspection after removal. Refer to [DLN-92, "Inspection"](#).

INSTALLATION

Note the following, and install in the reverse order of removal.

CAUTION:

Do not reuse propeller shaft nuts and bolts.

- After removing propeller shaft, replace stud bolts on electric controlled coupling. Refer to [DLN-108, "Removal and Installation"](#).
- Remove any moisture, oil, or foreign material from matching surface on transfer companion flange, electric controlled coupling and propeller shaft flange.
- Install center bearing mounting bracket (upper) with its arrow mark (A) facing forward.

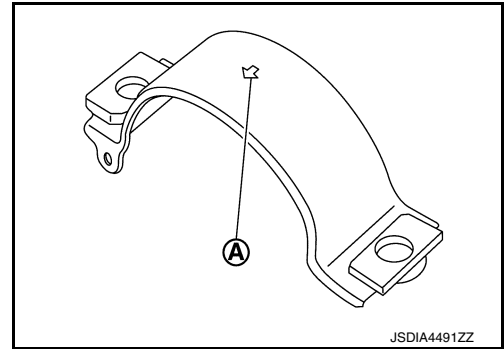

- Adjust position of center bearing mounting bracket (upper) (1), center bearing mounting bracket (lower) (2) sliding back and forth to prevent play in thrust direction of center bearing insulator (3). Install center bearing mounting bracket (upper/lower) to vehicle.
- Center bearing mounting bracket fixing nuts must be tightened in the order from left to right.

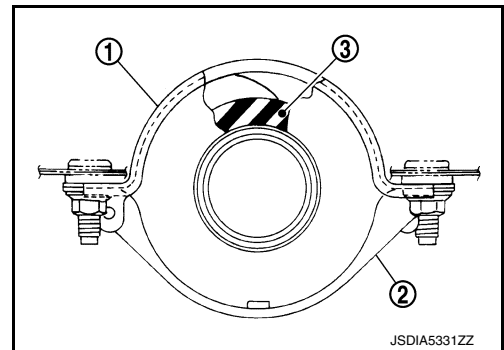

- Align matching marks (A) to install propeller shaft flange yoke and electric controlled coupling of final drive.

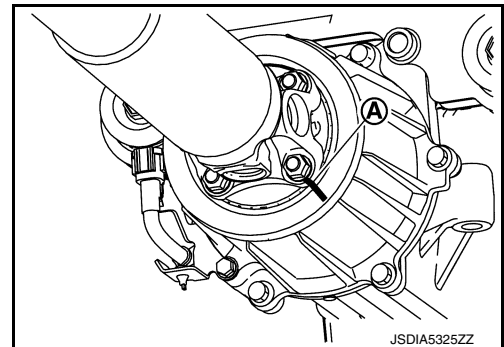

REAR PROPELLER SHAFT

[REAR PROPELLER SHAFT: C-CVJ-C]

< REMOVAL AND INSTALLATION >

- Align matching marks (A) to install propeller shaft flange yoke and transfer companion flange.

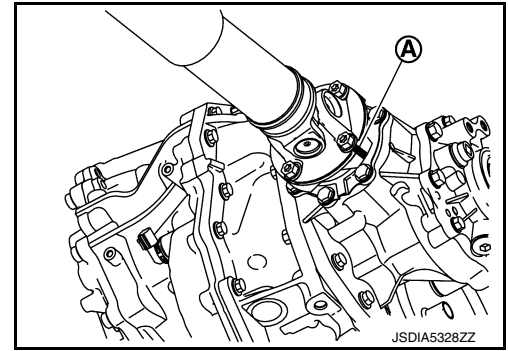

- If propeller shaft assembly, final drive assembly or electric controlled coupling has been replaced, connect propeller shaft assembly and electric controlled coupling of final drive as follows:
 - Install propeller shaft (1) while aligning its matching mark (A) of propeller shaft with matching mark (B) on stud bolt of electric controlled coupling (2) as close as possible.

CAUTION:

When replacing stud bolt, use the painted matching mark in removal as a guide.

- Perform inspection after installation. Refer to [DLN-92, "Inspection"](#).

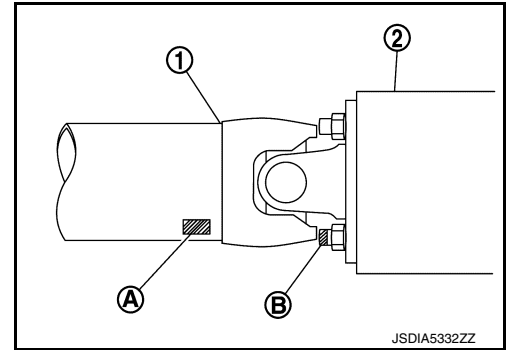

Inspection

INFOID:000000012892941

INSPECTION AFTER REMOVAL

Appearance

Check propeller shaft tube surface for dents or cracks. If malfunction is detected, replace propeller shaft assembly.

Propeller Shaft Runout

Check propeller shaft runout at measuring points with a dial indicator. If runout exceeds specifications, replace propeller shaft assembly.

Propeller shaft runout : Refer to [DLN-94, "Propeller Shaft Runout"](#).

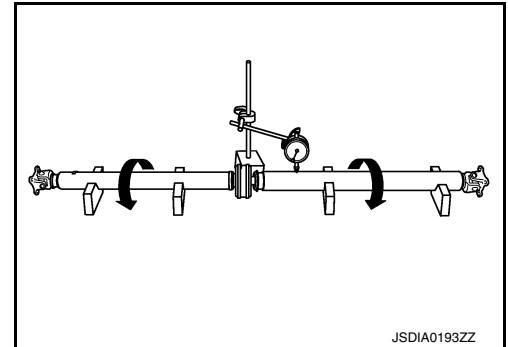

- Propeller shaft runout measuring point (Point "Δ").

↔ : Front side

Dimension

- A : 568 mm (22.36 in)
- B : 516 mm (20.31 in)

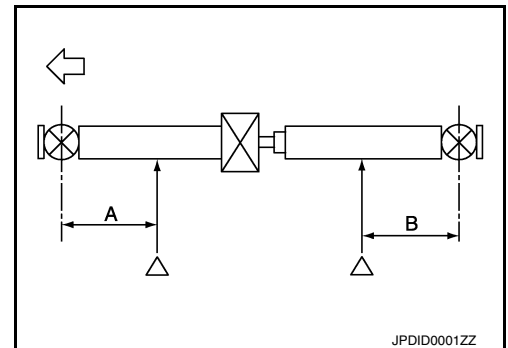

Journal Axial Play

REAR PROPELLER SHAFT

< REMOVAL AND INSTALLATION >

[REAR PROPELLER SHAFT: C-CVJ-C]

As shown in the figure, while fixing yoke on one side, check axial play of joint. If it is outside the standard, replace propeller shaft assembly.

Journal axial play : Refer to [DLN-94, "Journal Axial Play"](#).

CAUTION:
Never disassemble joints.

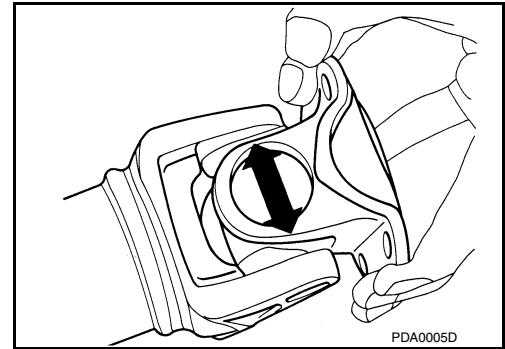

Center Bearing

Check center bearing for noise and damage. If malfunction is detected, replace propeller shaft assembly.

CAUTION:
Never disassemble center bearing.

INSPECTION AFTER INSTALLATION

After assembly, perform a driving test to check propeller shaft vibration. If vibration occurred, separate propeller shaft from final drive. Reinstall propeller shaft by changing the phase between electric controlled coupling stud bolt and propeller shaft by the one bolt hole at a time. Then perform driving test and check propeller shaft vibration again at each point.

A
B
C
DLN
E
F
G
H
I
J
K
L
M
N
O
P

SERVICE DATA AND SPECIFICATIONS (SDS)

< SERVICE DATA AND SPECIFICATIONS (SDS)

[REAR PROPELLER SHAFT: C-CVJ-C]

SERVICE DATA AND SPECIFICATIONS (SDS)

SERVICE DATA AND SPECIFICATIONS (SDS)

General Specifications

INFOID:0000000012892942

Applied model	Axle	AWD
	Engine	VQ35DE
	Transaxle	CVT
Propeller shaft model		C-CVJ-C
Number of joints		3
Joint type	1st joint	Universal (Shell type)
	2nd joint	CVJ type
	3rd joint	Universal (Shell type)
Coupling method	Transfer side	Flange type
	Rear final drive side	Flange type
Shaft length	1st (Spider to CVJ joint center)	1265 mm (49.80 in)
	2nd (CVJ joint center to spider)	1024 mm (40.31 in)
Shaft outer diameter	1st shaft	75 mm (2.95 in)
	2nd shaft	80 mm (3.15 in)

Propeller Shaft Runout

INFOID:0000000012892943

Unit: mm (in)

Item	Standard
Propeller shaft runout	0.8 (0.031) or less

Journal Axial Play

INFOID:0000000012892944

Unit: mm (in)

Item	Standard
Journal axial play	0 (0)

PRECAUTION

PRECAUTIONS

Precaution for Supplemental Restraint System (SRS) "AIR BAG" and "SEAT BELT PRE-TENSIONER"

INFOID:000000013460482

The Supplemental Restraint System such as "AIR BAG" and "SEAT BELT PRE-TENSIONER", used along with a front seat belt, helps to reduce the risk or severity of injury to the driver and front passenger for certain types of collision. Information necessary to service the system safely is included in the SR and SB section of this Service Manual.

WARNING:

- To avoid rendering the SRS inoperative, which could increase the risk of personal injury or death in the event of a collision which would result in air bag inflation, it is recommended that all maintenance and repair be performed by an authorized NISSAN/INFINITI dealer.
- Improper repair, including incorrect removal and installation of the SRS, can lead to personal injury caused by unintentional activation of the system. For removal of Spiral Cable and Air Bag Module, see the SR section.
- Do not use electrical test equipment on any circuit related to the SRS unless instructed to in this Service Manual. SRS wiring harnesses can be identified by yellow and/or orange harnesses or harness connectors.

PRECAUTIONS WHEN USING POWER TOOLS (AIR OR ELECTRIC) AND HAMMERS

WARNING:

- When working near the Air Bag Diagnosis Sensor Unit or other Air Bag System sensors with the Ignition ON or engine running, DO NOT use air or electric power tools or strike near the sensor(s) with a hammer. Heavy vibration could activate the sensor(s) and deploy the air bag(s), possibly causing serious injury.
- When using air or electric power tools or hammers, always switch the Ignition OFF, disconnect the battery or batteries, and wait at least three minutes before performing any service.

Precautions for Removing Battery Terminal

INFOID:000000012892945

- With the adoption of Auto ACC function, ACC power is automatically supplied by operating the Intelligent Key or remote keyless entry or by opening/closing the driver side door. In addition, ACC power is supplied even after the ignition switch is turned to the OFF position, i.e. ACC power is supplied for a certain fixed time.
- When disconnecting the 12V battery terminal, turn off the ACC power before disconnecting the 12V battery terminal, observing "How to disconnect 12V battery terminal" described below.

NOTE:

Some ECUs operate for a certain fixed time even after ignition switch is turned OFF and ignition power supply is stopped. If the battery terminal is disconnected before ECU stops, accidental DTC detection or ECU data damage may occur.

- For vehicles with the 2-batteries, be sure to connect the main battery and the sub battery before turning ON the ignition switch.

NOTE:

If the ignition switch is turned ON with any one of the terminals of main battery and sub battery disconnected, then DTC may be detected.

- After installing the 12V battery, always check "Self Diagnosis Result" of all ECUs and erase DTC.

NOTE:

The removal of 12V battery may cause a DTC detection error.

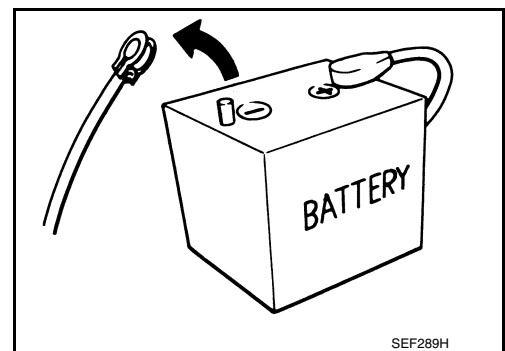

HOW TO DISCONNECT 12V BATTERY TERMINAL

Disconnect 12V battery terminal according to instruction described below.

1. Open the hood.
2. Turn ignition switch to the ON position.
3. Turn ignition switch to the OFF position with the driver side door opened.
4. Get out of the vehicle and close the driver side door.

A
B
C
DLN
E
F
G
H
I
J
K
L
M
N
O
P

PRECAUTIONS

[REAR FINAL DRIVE: R145]

< PRECAUTION >

5. Wait at least 3 minutes. For vehicle with the engine listed below, remove the battery terminal after a lapse of the specified time.

D4D engine	: 20 minutes	YS23DDT	: 4 minutes
HRA2DDT	: 12 minutes	YS23DDTT	: 4 minutes
K9K engine	: 4 minutes	ZD30DDTi	: 60 seconds
M9R engine	: 4 minutes	ZD30DDTT	: 60 seconds
R9M engine	: 4 minutes		
V9X engine	: 4 minutes		
YD25DDTi	: 2 minutes		

CAUTION:

While waiting, never operate the vehicle such as locking, opening, and closing doors. Violation of this caution results in the activation of ACC power supply according to the Auto ACC function.

6. Remove 12V battery terminal.

CAUTION:

After installing 12V battery, always check self-diagnosis results of all ECUs and erase DTC.

Service Notice or Precautions for Rear Final Drive

INFOID:000000012892946

- Use recommended gear oil only, refer to [MA-12. "Fluids and Lubricants"](#).
- Check for the correct installation status prior to removal or disassembly. If matching marks are required, be certain they never interfere with the function of the parts when applied.
- Overhaul should be done in a clean work area, it is preferable to work in dustproof area.
- Before disassembly, using steam or white gasoline, completely remove sand and mud from the exterior of the unit, preventing them from entering into the unit during disassembly or assembly.
- Check appearance of the disassembled parts for damage, deformation, and unusual wear. Replace them with a new ones if necessary.
- Gaskets, seals and O-rings should be replaced any time when the unit is disassembled.
- In principle, tighten bolts or nuts gradually in several steps working diagonally from inside to outside. If tightening sequence is specified, observe it.
- Clean and flush the parts sufficiently and blow-dry them.
- Be careful not to damage sliding surfaces and mating surfaces.
- When applying sealant, remove the old sealant from the mounting surface; then remove any moisture, oil, and foreign materials from the application and mounting surfaces.
- Always use shop paper for cleaning the inside of components.
- Never use cotton gloves or shop rags to prevent entering of lint.
- During assembly, observe the specified tightening torque, and apply new gear oil, petroleum jelly, or multi-purpose grease as specified for each vehicle, if necessary.

PREPARATION

< PREPARATION >

[REAR FINAL DRIVE: R145]

PREPARATION

PREPARATION

Special Service Tools

INFOID:000000012892947

The actual shape of the tools may differ from those illustrated here.

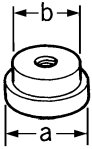
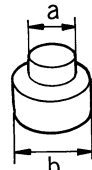
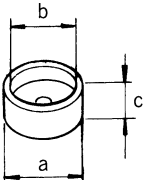
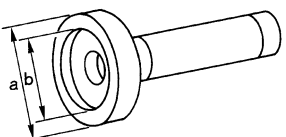
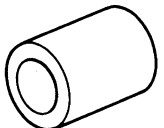
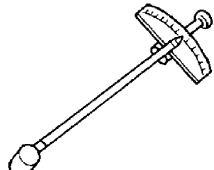
Tool number (TechMate No.) Tool name	Description
KV40100610 (J-26089) Drift a: 63 mm (2.48 in) dia. b: 54.3 mm (2.138 in) dia. <div style="text-align: center;">  <p>ZZA1000D</p> </div>	<ul style="list-style-type: none"> Removing and Installing rear cover (2 pieces are used.) Removing and Installing differential assembly (2 pieces are used.) Installing pinion front bearing inner race
ST33052000 (—) Adaptor a: 22 mm (0.87 in) dia. b: 28 mm (1.10 in) dia. <div style="text-align: center;">  <p>ZZA1023D</p> </div>	Removing side bearing inner race
KV40105020 (—) Drift a: 39.7 mm (1.563 in) dia. b: 35 mm (1.38 in) dia. c: 15 mm (0.59 in) <div style="text-align: center;">  <p>ZZA1133D</p> </div>	Installing side bearing inner race
KV38100200 (J-26233) Drift a: 65 mm (2.56 in) dia. b: 49 mm (1.93 in) dia. <div style="text-align: center;">  <p>ZZA1143D</p> </div>	Installing side oil seal
KV38109500 (—) Drive pinion socket <div style="text-align: center;">  <p>ZZA1205D</p> </div>	<ul style="list-style-type: none"> Measuring pinion bearing preload and total preload Removing and installing drive pinion lock nut
ST3127S000 (J-25765-A) Preload gauge <div style="text-align: center;">  <p>ZZA0503D</p> </div>	Measuring pinion bearing preload and total preload

A
B
C
DLN
E
F
G
H
I
J
K
L
M
N
O
P

PREPARATION

< PREPARATION >

[REAR FINAL DRIVE: R145]

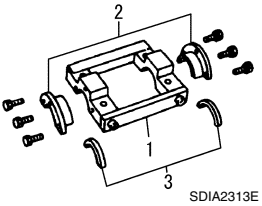
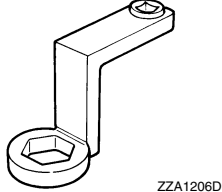
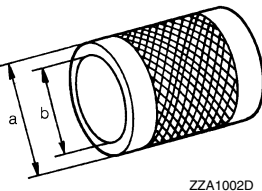
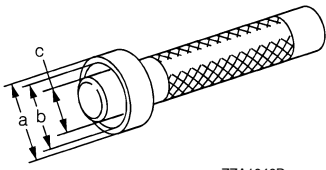
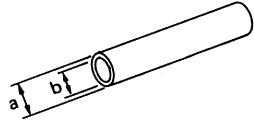
Tool number (TechMate No.) Tool name	Description
KV381086S1 (—) Dummy cover set 1. KV38108610 (—) Dummy cover 2. KV38108621 (—) Dummy cover spacer 3. KV38108630 (—) Dummy cover shim	 <ul style="list-style-type: none"> • Checking backlash • Checking drive gear runout • Checking tooth contact
KV38109400 (—) Pinion nut wrench	Removing and installing drive pinion lock nut 
ST33200000 (J-26082) Drift a: 60 mm (2.36 in) dia. b: 44.5 mm (1.752 in) dia.	Installing pinion rear bearing outer race 
ST33230000 (J-25805-01) Drift a: 51 mm (2.01 in) dia. b: 41 mm (1.61 in) dia. c: 28.5 mm (1.122 in) dia.	Installing pinion front bearing outer race 
ST23860000 (—) Drift a: 38 mm (1.50 in) dia. b: 33 mm (1.30 in) dia.	<ul style="list-style-type: none"> • Installing pinion rear bearing inner race • Installing pinion front bearing inner race 

PREPARATION

< PREPARATION >

[REAR FINAL DRIVE: R145]

Tool number (TechMate No.) Tool name	Description
ST38220000 (—) Press stand a: 75 mm (2.95 in) dia. b: 63 mm (2.48 in) dia.	Installing pinion front bearing inner race
ST35271000 (J-26091) Drift a: 72 mm (2.83 in) dia. b: 63 mm (2.48 in) dia.	Installing drive pinion oil seal

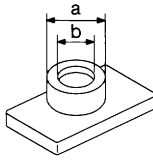

S-NT509

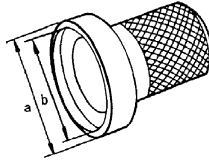

ZZA0814D

Commercial Service Tools

INFOID:0000000012892948

Tool name	Description
Oil seal remover	<ul style="list-style-type: none"> • Removing side oil seal • Removing drive pinion oil seal
Separator	<ul style="list-style-type: none"> • Removing side bearing inner race • Removing pinion rear bearing inner race
Puller	<ul style="list-style-type: none"> • Removing side bearing inner race • Removing pinion rear bearing inner race

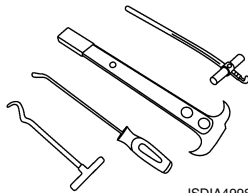

JSDIA4998ZZ

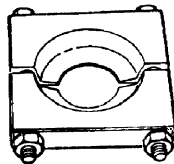

ZZA0700D

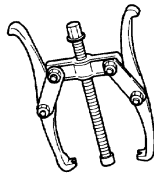



ZZA0119D

PREPARATION

< PREPARATION >

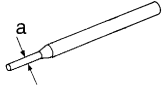
[REAR FINAL DRIVE: R145]

Tool name	Description
Pin punch a: 4.5 mm (0.177 in) dia.	Removing and installing lock pin
 NT410	
Power tool	Loosening nuts, screws and bolts
 PIIB1407E	

Lubricant or/and Sealant

INFOID:000000012892949

Item	Use
Red lead or equivalent	Checking tooth contact

SYSTEM DESCRIPTION

STRUCTURE AND OPERATION

Sectional View

INFOID:000000012892950

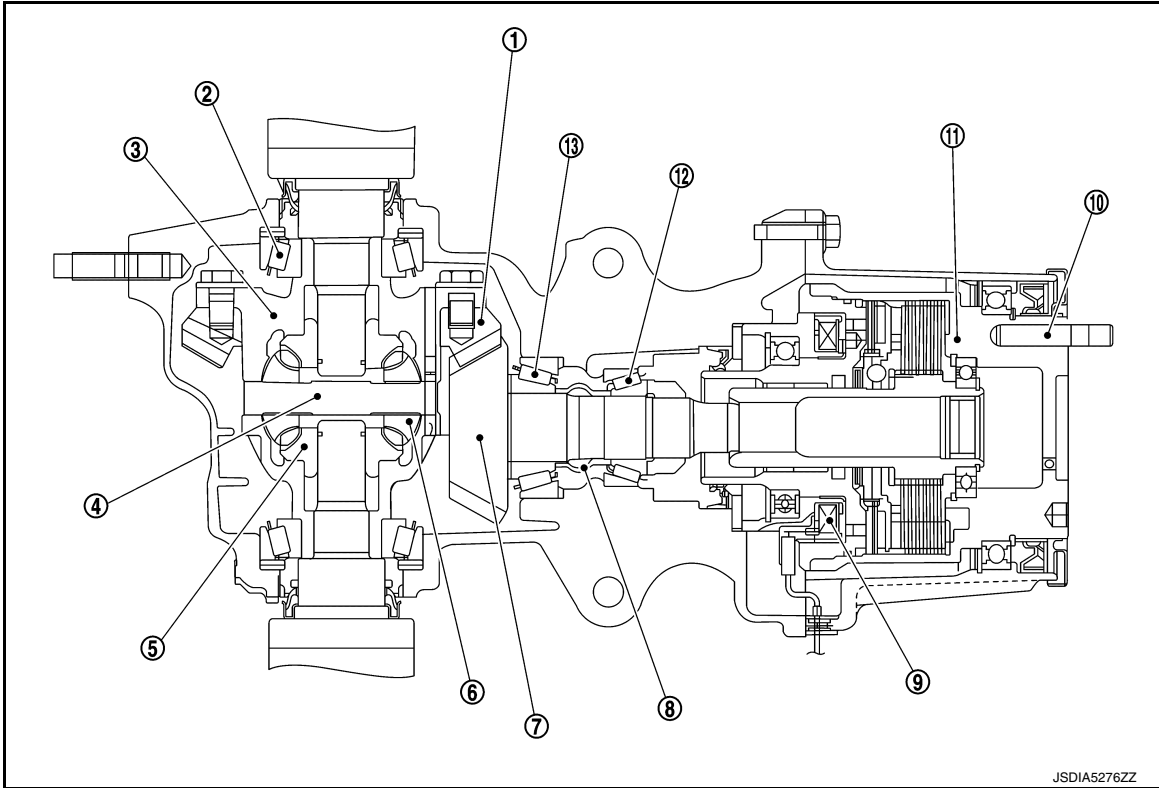

- | | | |
|-----------------------|--------------------------------|------------------------|
| ① Drive gear | ② Side bearing | ③ Differential case |
| ④ Pinion mate shaft | ⑤ Side gear | ⑥ Pinion mate gear |
| ⑦ Drive pinion | ⑧ Collapsible spacer | ⑨ AWD solenoid |
| ⑩ Stud bolt | ⑪ Electric controlled coupling | ⑫ Pinion front bearing |
| ⑬ Pinion rear bearing | | |

Electric Controlled Coupling

INFOID:000000012892951

The electric controlled coupling operates as the AWD system. For the operation, refer to [DLN-14, "Operation Description"](#).

A
B
C
DLN
E
F
G
H
I
J
K
L
M
N
O
P

NOISE, VIBRATION AND HARSHNESS (NVH) TROUBLESHOOTING

< SYMPTOM DIAGNOSIS >

[REAR FINAL DRIVE: R145]

SYMPTOM DIAGNOSIS

NOISE, VIBRATION AND HARSHNESS (NVH) TROUBLESHOOTING

NVH Troubleshooting Chart

INFOID:000000012892952

Use the chart below to find the cause of the symptom. If necessary, repair or replace these parts.

Symptom	Noise	Possible cause and SUSPECTED PARTS	Reference
	x	Gear tooth rough	DLN-133, "Inspection"
	x	Gear contact improper	DLN-129, "Adjustment"
	x	Tooth surfaces worn	DLN-133, "Inspection"
	x	Backlash incorrect	DLN-129, "Adjustment"
	x	Companion flange excessive runout	—
	x	Gear oil improper	DLN-103, "Inspection"
	x	PROPELLER SHAFT	NVH of REAR PROPELLER SHAFT in this section.
	x	AXLE AND SUSPENSION	NVH in FAX, RAX, FSU and RSU sections.
	x	TIRE	NVH in WT section.
	x	ROAD WHEEL	NVH in WT section.
	x	DRIVE SHAFT	NVH in FAX and RAX section.
	x	BRAKE	NVH in BR section.
	x	STEERING	NVH in ST section.

x: Applicable

PERIODIC MAINTENANCE

REAR DIFFERENTIAL GEAR OIL

Inspection

INFOID:0000000012892953

OIL LEAKAGE

Make sure that oil is not leaking from final drive assembly or around it.

OIL LEVEL

1. Check oil level from filler plug mounting hole as shown in the figure after removing filler plug (1) and gasket from final drive assembly.

CAUTION:

Turn the ignition switch OFF while checking oil level.

- Oil level should be level with bottom of filler plug mounting hole. Add gear oil if necessary. Refer to [DLN-103, "Refilling"](#).

2. Set a gasket on filler plug and install it on final drive assembly.

CAUTION:

Do not reuse gasket.

3. Tighten filler plug to the specified torque. Refer to [DLN-123, "Exploded View"](#).

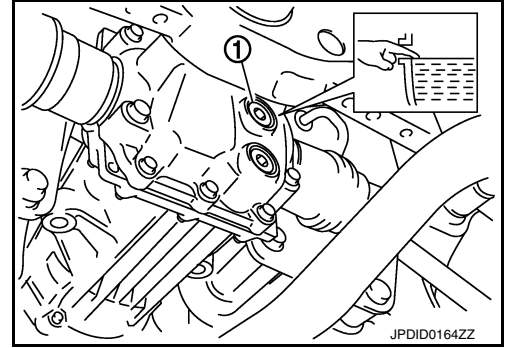

Draining

INFOID:0000000012892954

1. Turn the ignition switch OFF.
2. Remove drain plug (1) and gasket.
3. Drain gear oil.
4. Set a gasket on drain plug and install it to final drive assembly.

CAUTION:

Do not reuse gasket.

5. Tighten drain plug to the specified torque. Refer to [DLN-123, "Exploded View"](#).

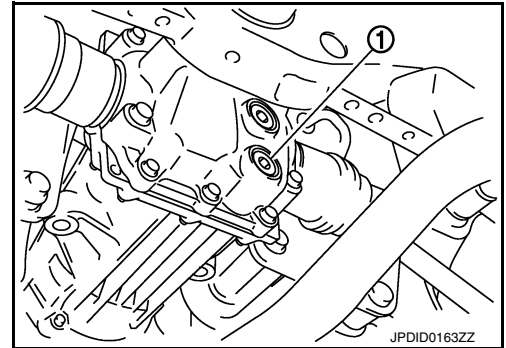

Refilling

INFOID:0000000012892955

1. Remove filler plug and gasket (1). Then fill with new gear oil until oil level reaches the specified level near filler plug mounting hole.

Recommended : Refer to [MA-12, "Fluids and Lubricants"](#).
oil and capacity

2. Set a gasket on filler plug, and install it to final drive assembly.

CAUTION:

Do not reuse gasket.

3. Tighten filler plug to the specified torque. Refer to [DLN-123, "Exploded View"](#).

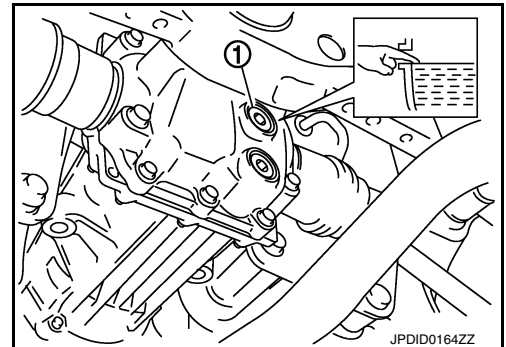

A
B
C
DLN
E
F
G
H
I
J
K
L
M
N
O
P

REMOVAL AND INSTALLATION

DRIVE PINION OIL SEAL

Exploded View

INFOID:000000012892956

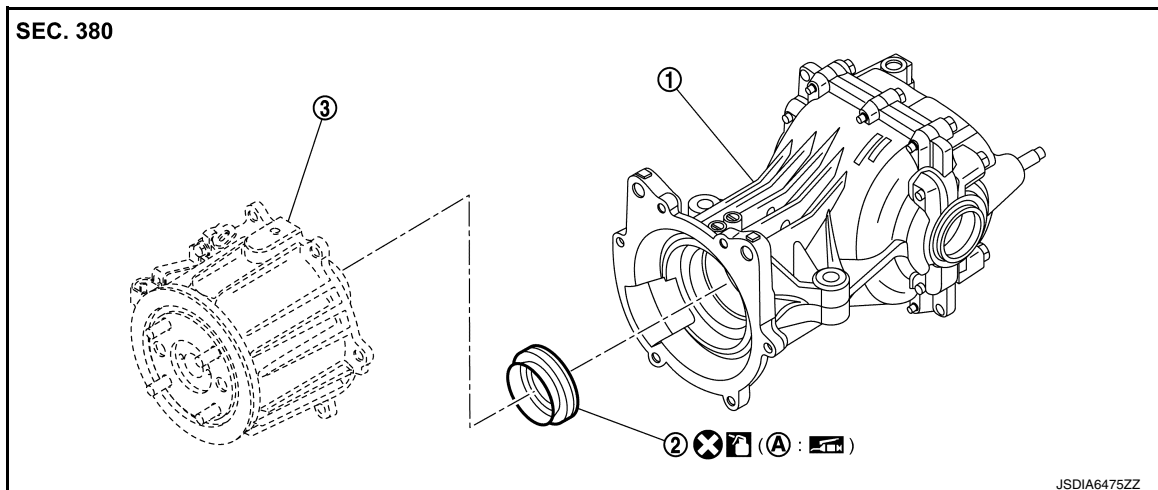

① Rear final drive assembly ② Drive pinion oil seal ③ Electric controlled coupling assembly

(A) Oil seal lip

⊗: Always replace after every disassembly.

🛢️: Apply gear oil.

🛠️: Apply multi-purpose grease.

Removal and Installation

INFOID:000000012892957

REMOVAL

1. Drain gear oil. Refer to [DLN-103, "Draining"](#).
2. Remove electric controlled coupling assembly. Refer to [DLN-108, "Removal and Installation"](#).
3. Remove drive pinion oil seal using oil seal remover (commercial service tool).

INSTALLATION

1. Install drive pinion oil seal (1) using Tool (A).

Oil seal installation length (D) : 0.8 – 1.2 mm (0.031 – 0.047 in)

Tool number : ST35271000 (—)

CAUTION:

- Do not reuse oil seal.
- When installing, never incline oil seal.
- Apply multi-purpose grease onto oil seal lips, and gear oil onto the circumference of oil seal.

2. Install electric controlled coupling assembly. Refer to [DLN-108, "Removal and Installation"](#).
3. Refill gear oil to the final drive. Refer to [DLN-103, "Refilling"](#).
4. Perform inspection after installation. Refer to [DLN-104, "Inspection"](#).

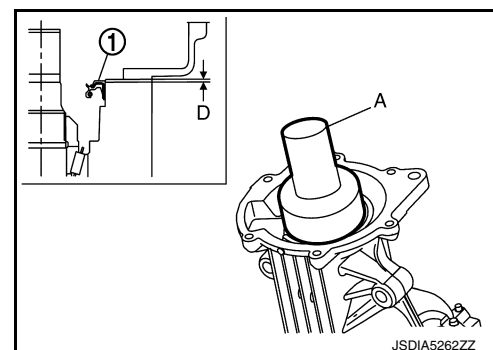

Inspection

INFOID:000000012892958

INSPECTION AFTER INSTALLATION

DRIVE PINION OIL SEAL

< REMOVAL AND INSTALLATION >

[REAR FINAL DRIVE: R145]

Check oil level and final drive for oil leakage. Refer to [DLN-103, "Inspection"](#).

A

B

C

DLN

E

F

G

H

I

J

K

L

M

N

O

P

SIDE OIL SEAL

< REMOVAL AND INSTALLATION >

[REAR FINAL DRIVE: R145]

SIDE OIL SEAL

Exploded View

INFOID:000000012892959

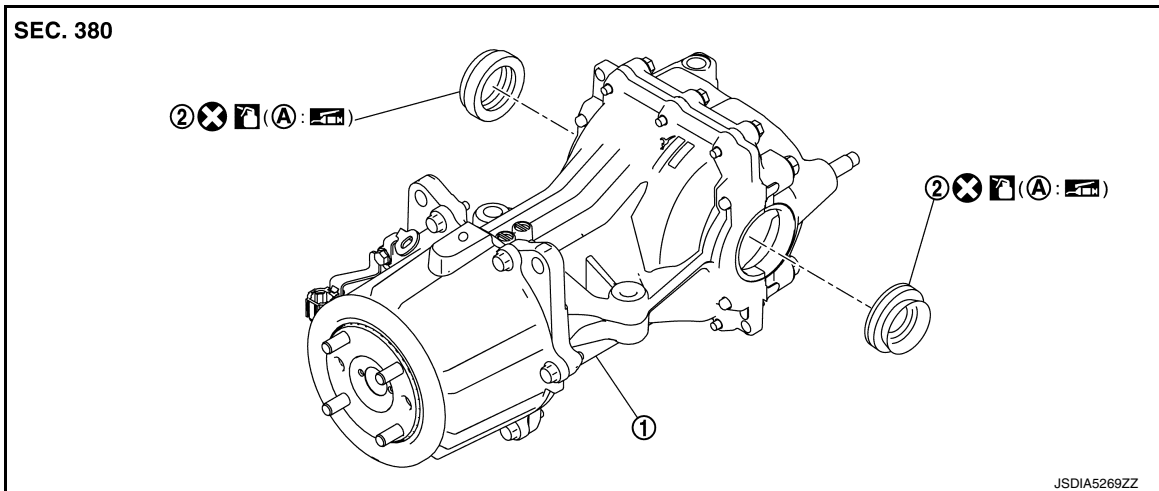

① Rear final drive assembly ② Side oil seal

(A) Oil seal lip

(X): Always replace after every disassembly.

(A): Apply gear oil.

(B): Apply multi-purpose grease.

Removal and Installation

INFOID:000000012892960

REMOVAL

1. Drain gear oil. Refer to [DLN-103, "Draining"](#).
2. Remove rear drive shafts. Refer to [RAX-11, "Removal and Installation"](#).
3. Remove side oil seal, using oil seal remover (commercial service tool).

CAUTION:

Do not damage gear carrier and rear cover.

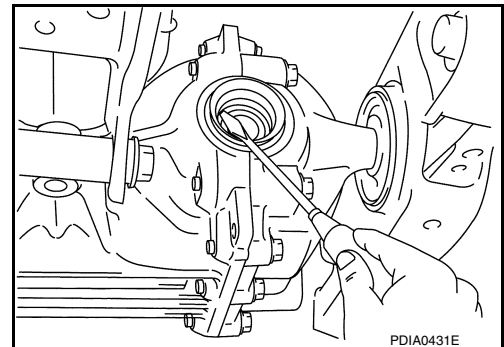

INSTALLATION

1. Using the drift (A) (SST: KV38100200), drive side oil seal until it becomes flush with the gear carrier end.
CAUTION:
 - Do not reuse oil seal.
 - When installing, never incline oil seal.
 - Apply multi-purpose grease onto oil seal lip, and gear oil onto the circumference of oil seal.
2. Install rear drive shafts. Refer to [RAX-11, "Removal and Installation"](#).
3. Refill gear oil to the final drive. Refer to [DLN-103, "Refilling"](#).

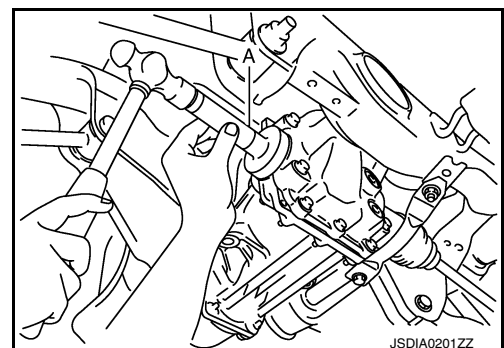

SIDE OIL SEAL

< REMOVAL AND INSTALLATION >

[REAR FINAL DRIVE: R145]

Inspection

INFOID:000000012892961

INSPECTION AFTER INSTALLATION

Check oil level and final drive for oil leakage. Refer to [DLN-103. "Inspection"](#).

A

B

C

DLN

E

F

G

H

I

J

K

L

M

N

O

P

ELECTRIC CONTROLLED COUPLING

< REMOVAL AND INSTALLATION >

[REAR FINAL DRIVE: R145]

ELECTRIC CONTROLLED COUPLING

Exploded View

INFOID:000000012892962

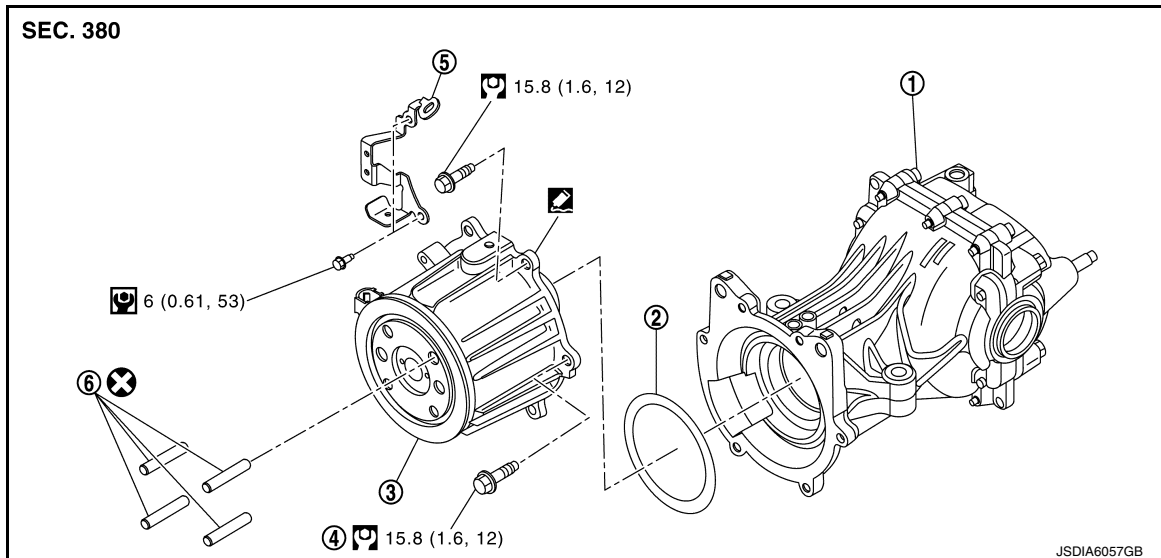

- ① Rear final drive assembly
- ② Wave spring
- ③ Electric controlled coupling assembly
- ④ Reamer bolt
- ⑤ Connector bracket
- ⑥ Stud bolt

: N·m (kg·m, in·lb)

: N·m (kg·m, ft·lb)

: Always replace after every disassembly.

: Apply Genuine Silicone RTV or equivalent. Refer to [GI-22. "Recommended Chemical Products and Sealants"](#).

Removal and Installation

INFOID:000000012892963

REMOVAL

1. Drain gear oil. Refer to [DLN-103. "Draining"](#).
2. Remove propeller shaft from rear final drive assembly. Refer to [DLN-89. "Removal and Installation"](#).
3. Remove stud bolts (1).

CAUTION:

After removing propeller shaft, replace stud bolt.

NOTE:

When replacing electric controlled coupling assembly, stud bolts are not required to be removed.

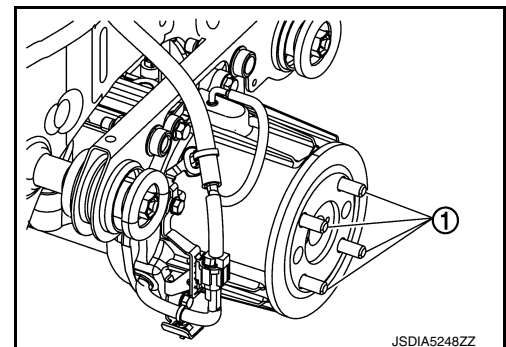

ELECTRIC CONTROLLED COUPLING

< REMOVAL AND INSTALLATION >

[REAR FINAL DRIVE: R145]

4. Disconnect AWD solenoid harness connector (1).

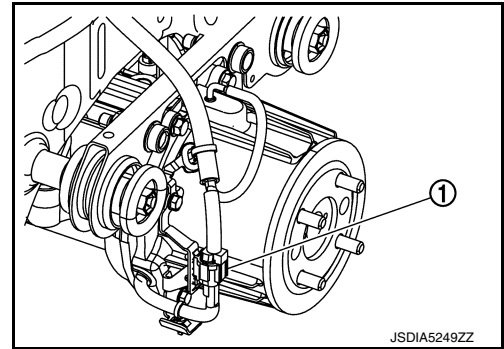

5. Remove air breather hose (1) from electric controlled coupling assembly. Refer to [DLN-113, "Removal and Installation"](#).

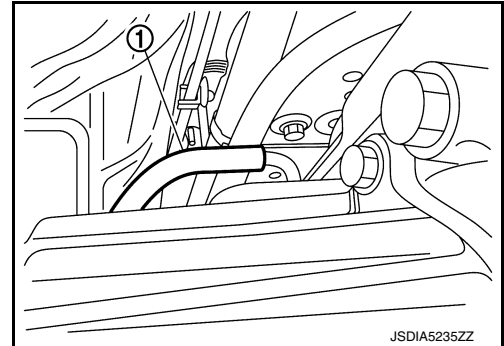

6. Remove electric controlled coupling assembly from final drive assembly.
7. Remove wave spring.
8. Remove drive pinion oil seal from the inside of gear carrier. Refer to [DLN-104, "Removal and Installation"](#).

CAUTION:

When removing electric controlled coupling, replace drive pinion oil seal.

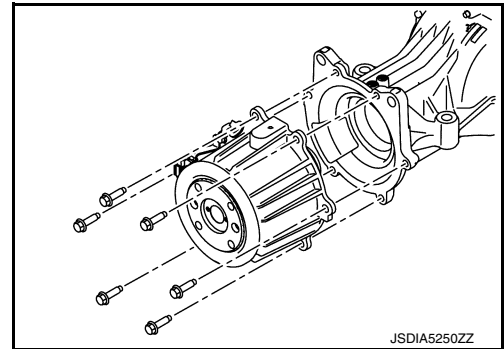

9. Remove connector bracket (1) from electric controlled coupling.

← bolt

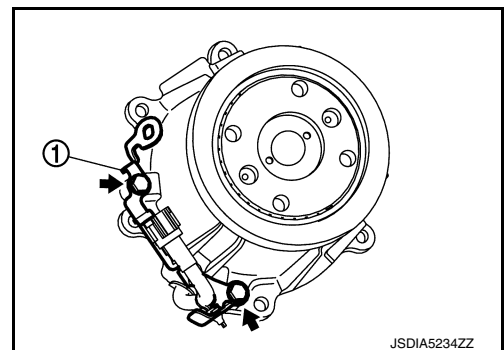

10. Remove band clip and connector clip to disconnect connector bracket from AWD solenoid harness connector.

← Clip

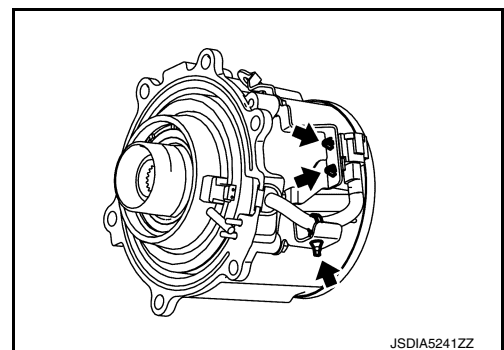

A
B
C
DLN
E
F
G
H
I
J
K
L
M
N
O
P

ELECTRIC CONTROLLED COUPLING

< REMOVAL AND INSTALLATION >

[REAR FINAL DRIVE: R145]

INSTALLATION

1. Install connector bracket to electric controlled coupling.
 - For tightening torque, refer to [DLN-108, "Exploded View"](#).
2. Lock AWD solenoid harness with band clip and connector clip.
3. Install drive pinion oil seal to the inside of gear carrier. Refer to [DLN-104, "Removal and Installation"](#).

CAUTION:

When removing electric controlled coupling, replace drive pinion oil seal.

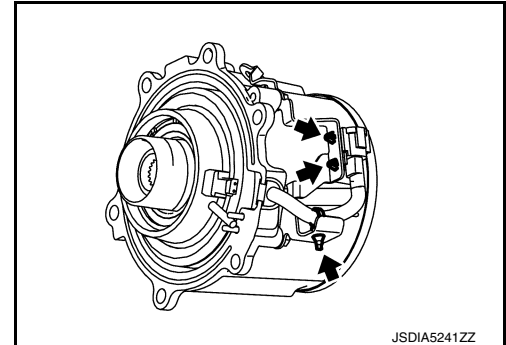

4. Install wave spring (1) to the inside of gear carrier.

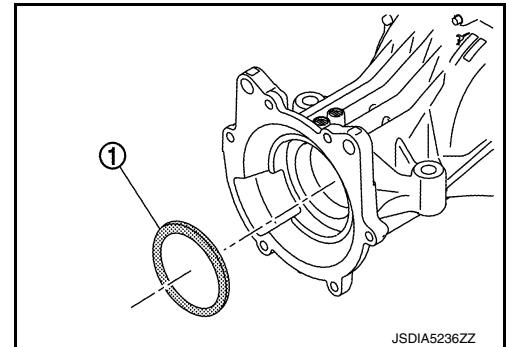

5. Apply liquid gasket to mating surface of electric controlled coupling assembly.
 - For applying liquid gasket, refer to [DLN-108, "Exploded View"](#).

CAUTION:

- Remove old gasket adhering to the mounting surfaces. Also remove any moisture, oil, or foreign material adhering to the mounting surfaces.
- The width of sealant bead is approximately 3 mm (0.12 in). Apply sealant evenly.

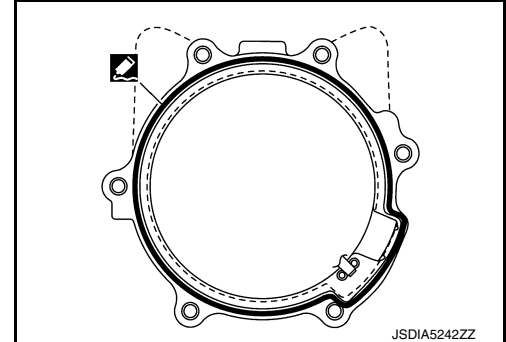

6. Join electric controlled coupling assembly (1) to spline of drive pinion, then install it to final drive assembly (2).

CAUTION:

Be careful not to damage drive pinion oil seal.

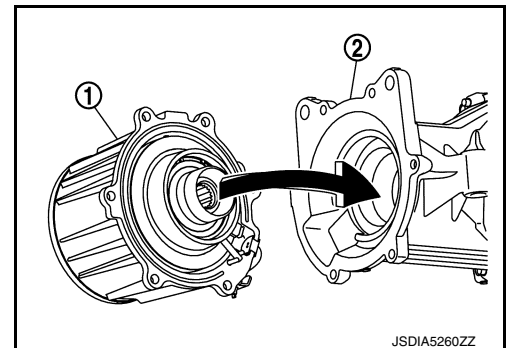

ELECTRIC CONTROLLED COUPLING

< REMOVAL AND INSTALLATION >

[REAR FINAL DRIVE: R145]

- Temporarily tighten reamer bolts (1) to the positions shown in the figure.
- Tighten reamer bolts and electric controlled coupling assembly mounting bolts to the specified torque.
 - For tightening torque, refer to [DLN-108, "Exploded View"](#).

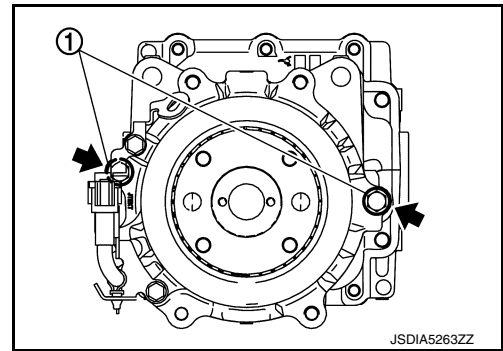

- Install air breather hose (1) to electric controlled coupling assembly. Refer to [DLN-113, "Removal and Installation"](#).

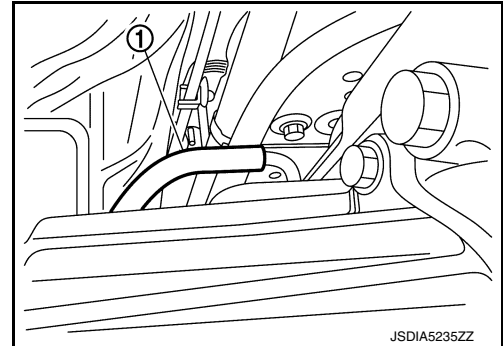

- Connect AWD solenoid harness connector (1).

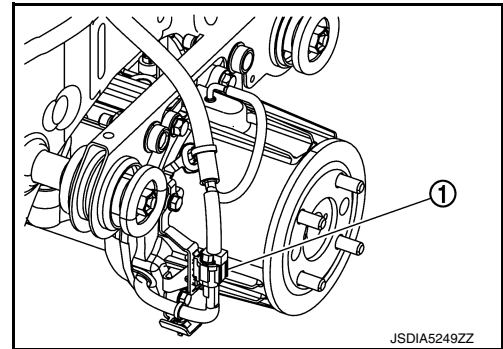

- Install stud bolts (1).

⇐ : Electric controlled coupling side

Thread length

A : Long

B : Short

CAUTION:

- Do not reuse stud bolt.
- After removing propeller shaft, replace stud bolt.
- Screw long thread side of stud bolt to electric controlled coupling.
- Screw the stud bolt until the stop by applying a torque of 15 N·m (1.5 kg·m, 11 ft·lb) ±20%.

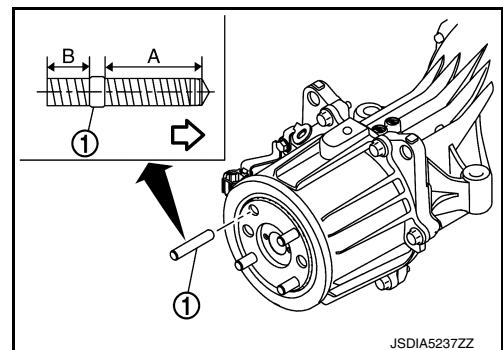

A
B
C
DLN
E
F
G
H
I
J
K
L
M
N
O
P

ELECTRIC CONTROLLED COUPLING

< REMOVAL AND INSTALLATION >

[REAR FINAL DRIVE: R145]

- After installing stud bolt, the length of the protrusion from electric controlled coupling must be as described below.

Length (L) : 19.8 mm (0.780 in) ±1.4 mm (0.055 in)

NOTE:

When replacing electric controlled coupling assembly, stud bolts are not required to be installed.

12. Install propeller shaft. Refer to [DLN-89, "Removal and Installation"](#).
13. Refill gear oil to the final drive. Refer to [DLN-103, "Refilling"](#).
14. Perform inspection and adjustment after installation. Refer to [DLN-112, "Inspection and Adjustment"](#).

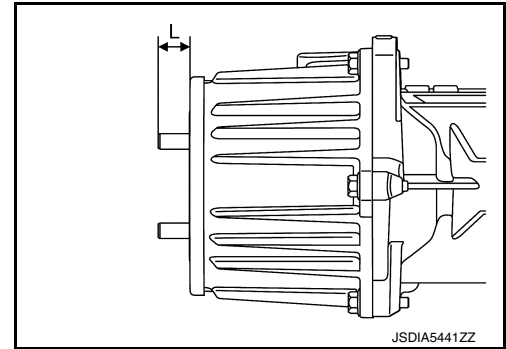

Inspection and Adjustment

INFOID:000000012892964

INSPECTION AFTER INSTALLATION

Check oil level and final drive for oil leakage. Refer to [DLN-103, "Inspection"](#).

ADJUSTMENT AFTER INSTALLATION

When replaced electric controlled coupling, perform writing unit characteristics. Refer to [DLN-33, "Description"](#).

AIR BREATHER

< REMOVAL AND INSTALLATION >

[REAR FINAL DRIVE: R145]

AIR BREATHER

Exploded View

INFOID:000000012892965

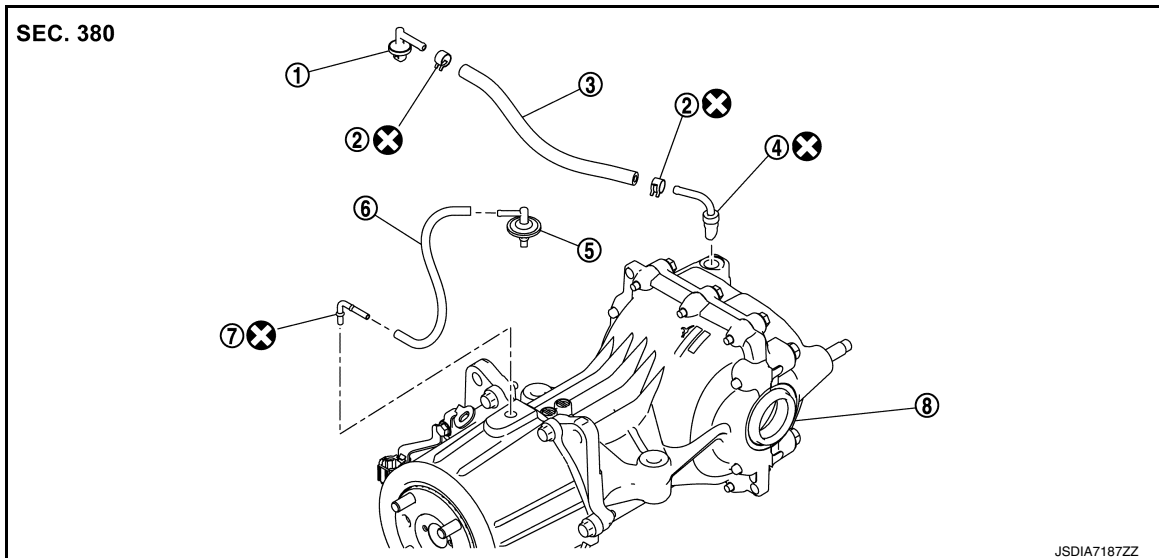

- | | | |
|------------------------------|------------------------------|---------------------|
| ① Breather connector (resin) | ② Hose clamp | ③ Air breather hose |
| ④ Breather connector (metal) | ⑤ Breather connector (resin) | ⑥ Air breather hose |
| ⑦ Breather connector (metal) | ⑧ Rear final drive assembly | |

⊗: Always replace after every disassembly.

Removal and Installation

INFOID:000000012892966

REMOVAL

Final Drive Side

1. Remove hose clamp, and remove air breather hose from breather connector (metal) on rear final drive assembly.
2. Remove breather connector (resin) together with air breather hose from bracket.
3. Remove hose clamp, and remove air breather hose from breather connector (resin).
4. Remove trim clip and remove bracket.
5. Remove breather connector (metal) from rear final drive assembly.
 - When removing/installing breather connector (metal), remove rear final drive assembly from the vehicle. Refer to [DLN-116, "Removal and Installation"](#).

Electric Controlled Coupling Side

1. Remove air breather hose assembly from breather connector (metal) on electric controlled coupling assembly.
2. Remove air breather hose assembly from hose connector.
3. Remove clip from suspension member.
4. Remove breather connector (resin) (1) together with air breather hose (3) and hose connector from bracket.
5. Remove trim clip and remove bracket.
6. Remove breather connector (metal) (2) from electric controlled coupling assembly.
 - When removing/installing breather connector (metal) (2), remove electric controlled coupling assembly from rear final drive assembly. Refer to [DLN-108, "Removal and Installation"](#).

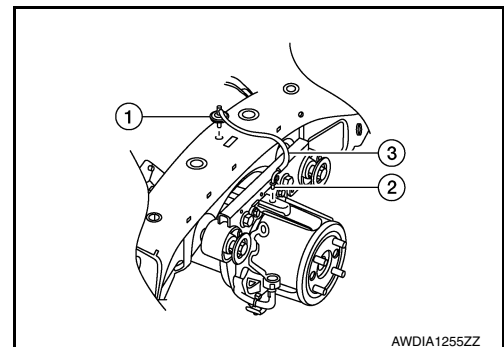

AIR BREATHER

< REMOVAL AND INSTALLATION >

[REAR FINAL DRIVE: R145]

INSTALLATION

Note the following, and install in the reverse order of removal.

- When installing air breather hose, make sure there are no pinched or restricted areas on air breather hose caused by bending or winding.

Final Drive Side

- Set breather connector (metal) (1) to rear final drive assembly with the paint mark (A) facing vehicle front.

⇐ : Front

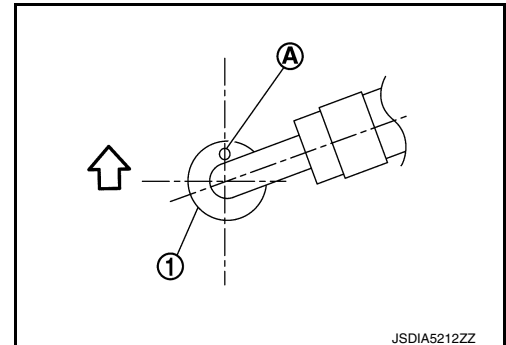

- Observe the following instructions to install breather connector (resin) (1), air breather hose (2), breather connector (metal) (3), and hose clamp (4) as shown in the figure.

CAUTION:

- Be careful with insert dimension of breather connector and set position of hose clamp.

Insert dimension of breather connector (resin/metal) : 20 mm (0.79 in) from breather connector end (air breather hose side)

Set position of hose clamp : 5 mm (0.20 in) from breather hose end

- Be careful with orientation of hose clamp tab.
- Set bracket with the stopper (A) facing vehicle inside.

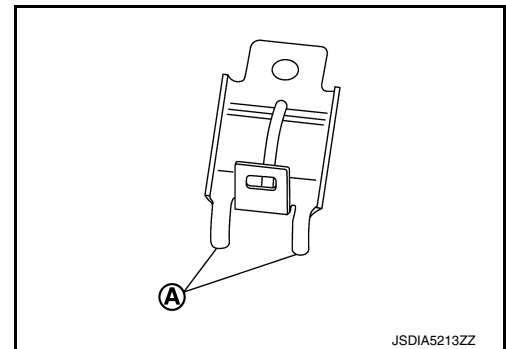
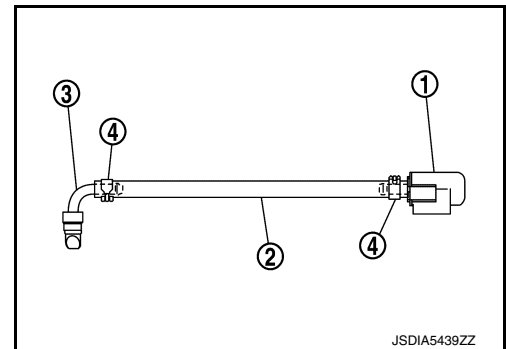

Electric Controlled Coupling Side

- Securely install breather connector (metal) to the electric controlled coupling assembly with the tip of tube faced in the vehicle front direction. In addition, insert air breather hose (1) to tube spool part (A) of breather connector (metal) (2).

⇐ : Front

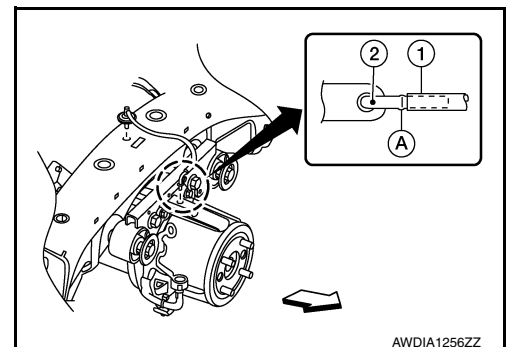

AIR BREATHER

< REMOVAL AND INSTALLATION >

[REAR FINAL DRIVE: R145]

- Install breather connector (resin) (1), air breather hose (2), hose connector (3), and clip (4) based on hose paint mark (A) as shown in the figure, complying with the directions below.

CAUTION:

- **Be careful with insert dimension of breather connector (resin) and hose connector, and set position of clip.**

Insert dimension of breather connector (resin) and hose connector : 15 mm (0.59 in) from breather connector end (air breather hose side) and hose connector end (air breather hose side)

Set position of clip : 5 mm (0.20 in) from breather hose end

- **Cut extra band of clip.**

- Set bracket with the stopper (A) facing vehicle inside.

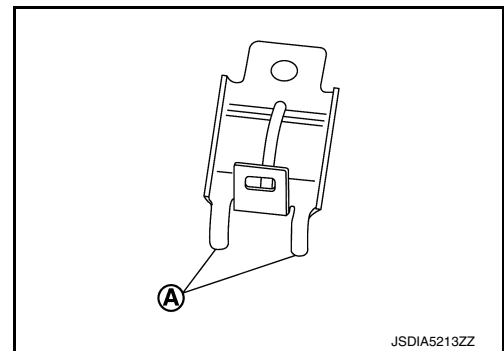
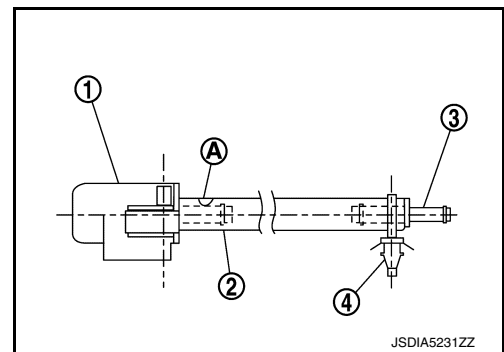

A
B
C
DLN
E
F
G
H
I
J
K
L
M
N
O
P

REAR FINAL DRIVE ASSEMBLY

< UNIT REMOVAL AND INSTALLATION >

[REAR FINAL DRIVE: R145]

UNIT REMOVAL AND INSTALLATION

REAR FINAL DRIVE ASSEMBLY

Exploded View

INFOID:000000012892967

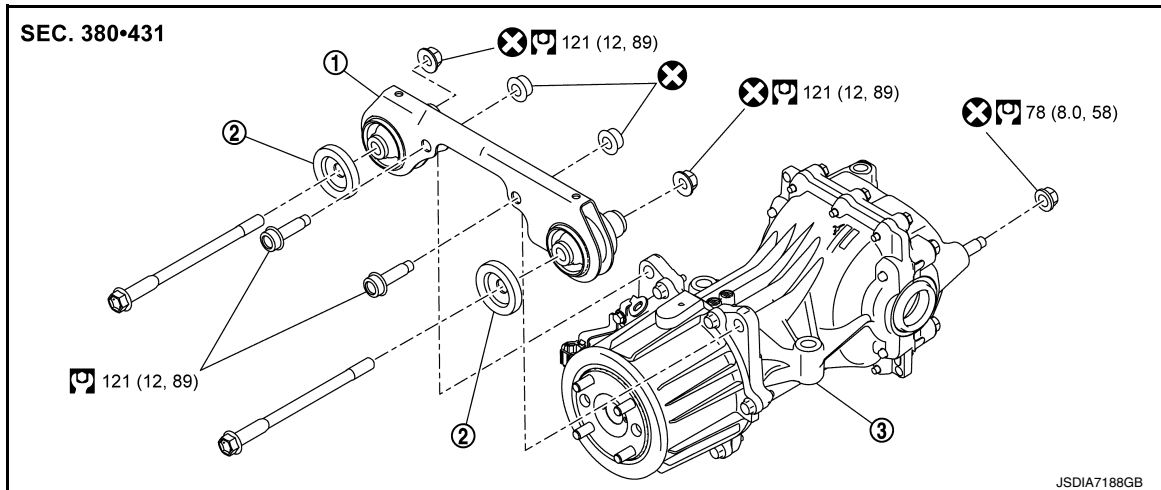

1. Final drive bracket

2. Stopper

3. Rear final drive assembly

Removal and Installation

INFOID:000000012892968

REMOVAL

1. Remove rear drive shaft. Refer to [RAX-11, "Removal and Installation"](#).

CAUTION:

Oil may leak from the opening. Use cap and/or plug to prevent leakage.

2. Remove propeller shaft from rear final drive assembly. Refer to [DLN-89, "Removal and Installation"](#).

CAUTION:

After removing propeller shaft, replace stud bolt (1).

NOTE:

When replacing rear final drive assembly, stud bolts are not required to be removed.

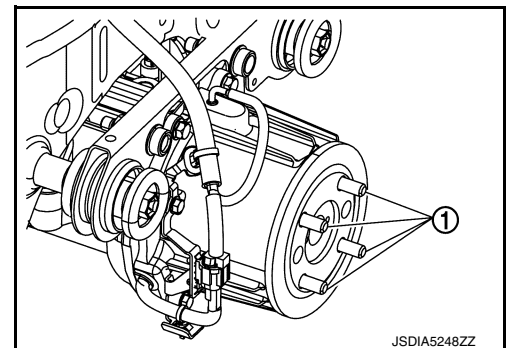

3. Disconnect harness connector (1) from AWD solenoid.
4. Remove air breather hoses from rear final drive and electric controlled coupling assembly. Refer to [DLN-108, "Removal and Installation"](#).
5. Remove fuel tank protector. Refer to [FL-11, "FWD : Exploded View"](#) (FWD models), [FL-15, "AWD : Exploded View"](#) (AWD models).
6. Set a suitable jack to rear final drive assembly.

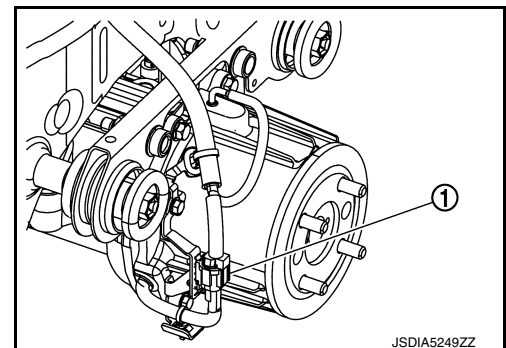

REAR FINAL DRIVE ASSEMBLY

< UNIT REMOVAL AND INSTALLATION >

[REAR FINAL DRIVE: R145]

- Remove rear final drive assembly nut (A) at rear suspension member.

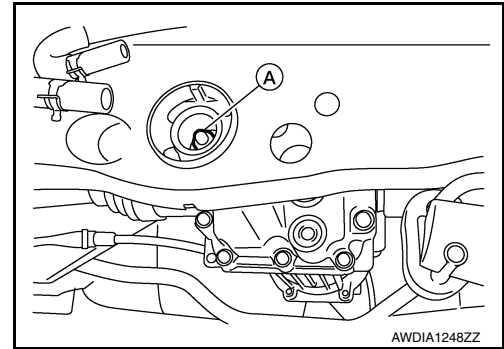

A
B
C

- Remove bolts and nuts (A) engaging final drive bracket with rear suspension member.

CAUTION:

Secure rear final drive assembly to suitable jack.

- Remove stoppers.

- Remove rear final drive assembly.

CAUTION:

Secure rear final drive assembly to suitable jack while removing it.

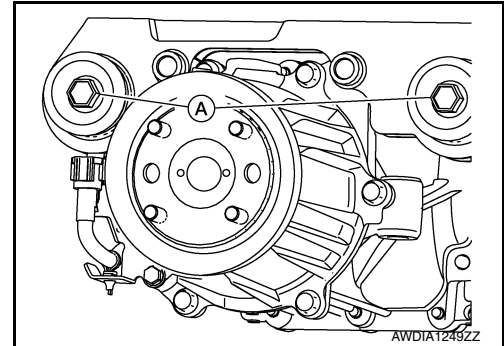

DLN

E
F
G

- Remove bolts and nuts (A) engaging final drive bracket with rear final drive assembly.

- Remove final drive bracket.

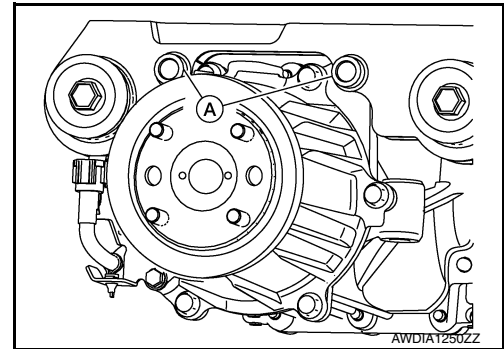

H
I
J

INSTALLATION

Installation is in the reverse order of removal.

CAUTION:

- Do not reuse final drive nuts.
- When replacing rear final drive assembly, perform writing unit characteristics. Refer to [DLN-33, "Description"](#).
- Be careful not to install wrong stud bolt (1) direction.

⇐ : Electric controlled coupling side

Thread length

(A) : Long

(B) : Short

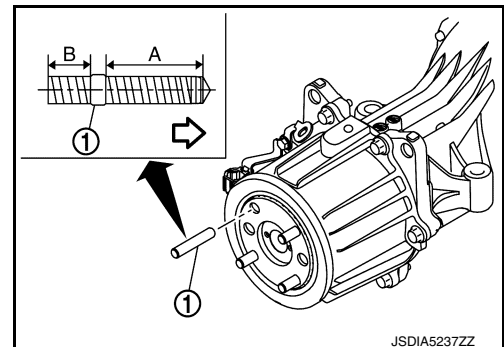

K
L
M

N
O
P

CAUTION:

- After removing propeller shaft, replace stud bolt.
- Screw long thread side of stud bolt to electric controlled coupling.
- Screw the stud bolt until the stop by applying a torque of 15 N·m (1.5 kg·m, 11 ft·lb) ±20%.

REAR FINAL DRIVE ASSEMBLY

< UNIT REMOVAL AND INSTALLATION >

[REAR FINAL DRIVE: R145]

- After installing stud bolt, the length of the protrusion from electric controlled coupling must be as described below.

Length (L) : 19.8 mm (0.780 in) ±1.4 mm (0.055 in)

NOTE:

When replacing rear final drive assembly, stud bolts are not required to be installed.

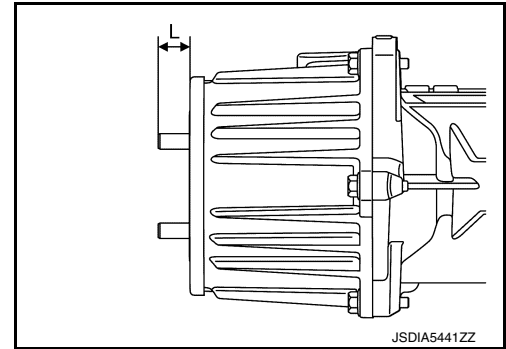

Inspection and Adjustment

INFOID:000000012892969

INSPECTION AFTER INSTALLATION

When oil leaks while removing/installing final drive assembly, check oil level after the installation. Refer to [DLN-103. "Inspection"](#).

ADJUSTMENT AFTER INSTALLATION

When replaced rear final drive assembly or electric controlled coupling was changed, perform writing unit characteristics. Refer to [DLN-33. "Description"](#).

ELECTRIC CONTROLLED COUPLING

< UNIT DISASSEMBLY AND ASSEMBLY >

[REAR FINAL DRIVE: R145]

UNIT DISASSEMBLY AND ASSEMBLY

ELECTRIC CONTROLLED COUPLING

Exploded View

INFOID:000000012892970

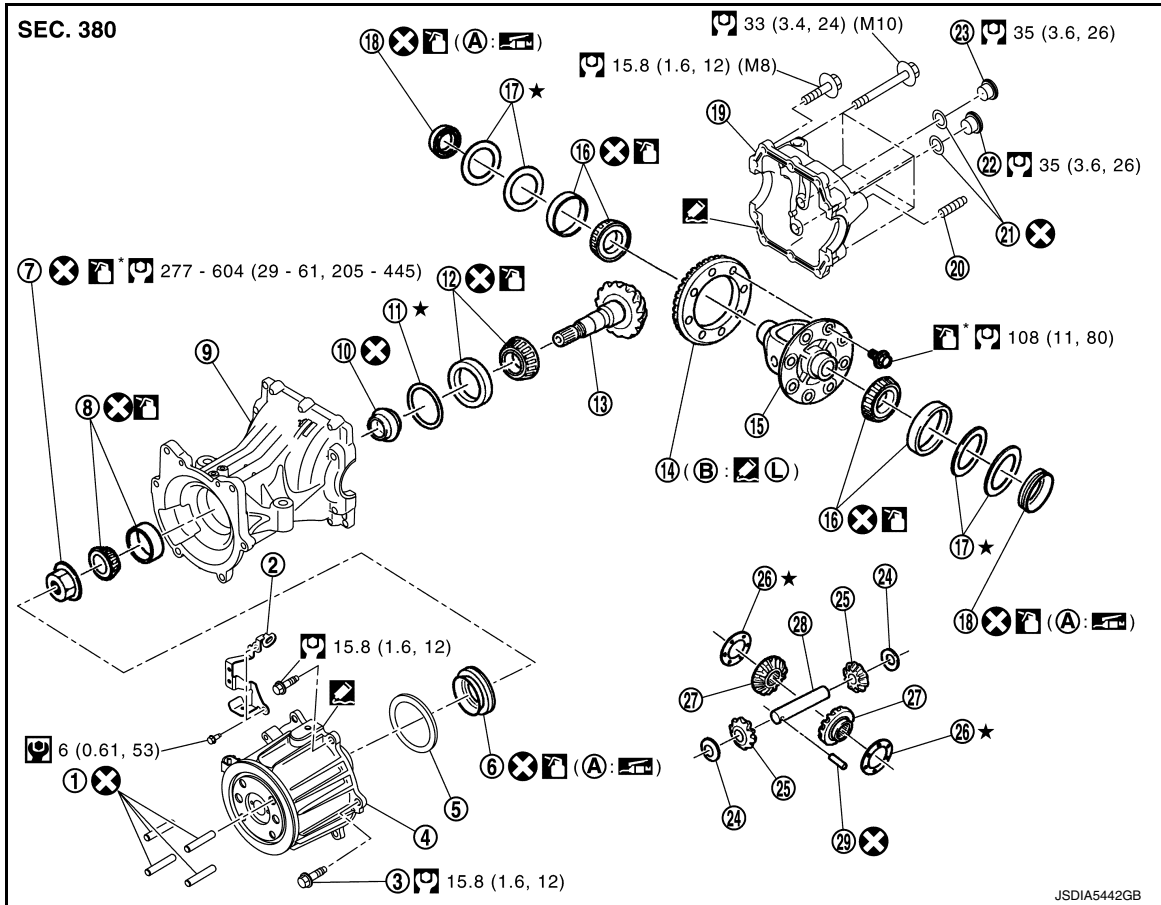

- | | | |
|---|-------------------------------|-----------------------------|
| ① Stud bolt | ② Connector bracket | ③ Reamer bolt |
| ④ Electric controlled coupling assembly | ⑤ Wave spring | ⑥ Drive pinion oil seal |
| ⑦ Drive pinion lock nut | ⑧ Pinion front bearing | ⑨ Gear carrier |
| ⑩ Collapsible spacer | ⑪ Drive pinion adjusting shim | ⑫ Pinion rear bearing |
| ⑬ Drive pinion | ⑭ Drive gear | ⑮ Differential case |
| ⑯ Side bearing | ⑰ Side bearing adjusting shim | ⑱ Side oil seal |
| ⑲ Rear cover | ⑳ Stud bolt | ㉑ Gasket |
| ㉒ Drain plug | ㉓ Filler plug | ㉔ Pinion mate thrust washer |
| ㉕ Pinion mate gear | ㉖ Side gear thrust washer | ㉗ Side gear |
| ㉘ Pinion mate shaft | ㉙ Lock pin | |
| (A) Oil seal lip | (B) Screw hole | |

N·m (kg·m, in·lb)

N·m (kg·m, ft·lb)

Always replace after every disassembly.

Select with proper thickness.

Apply gear oil.

ELECTRIC CONTROLLED COUPLING

< UNIT DISASSEMBLY AND ASSEMBLY >

[REAR FINAL DRIVE: R145]

*: Apply anti-corrosion oil.

: Apply multi purpose grease.

: Apply Genuine Silicone RTV or equivalent. Refer to [GI-22. "Recommended Chemical Products and Sealants"](#).

L: Apply Genuine High Strength Thread Locking Sealant or equivalent. Refer to [GI-22. "Recommended Chemical Products and Sealants"](#).

Disassembly and Assembly

INFOID:000000012892971

DISASSEMBLY

1. Remove stud bolts ①.

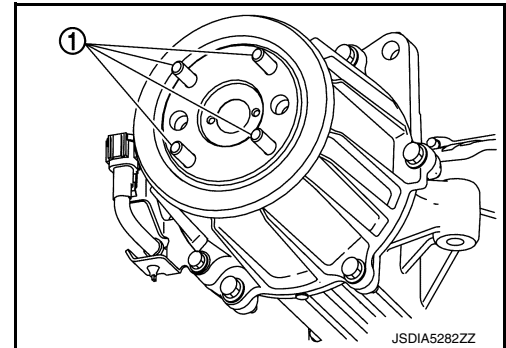

2. Remove electric controlled coupling assembly from final drive assembly.

3. Remove wave spring.

4. Remove drive pinion oil seal from the inside of gear carrier. Refer to [DLN-135. "Disassembly and Assembly"](#).

CAUTION:

When removing electric controlled coupling, replace drive pinion oil seal.

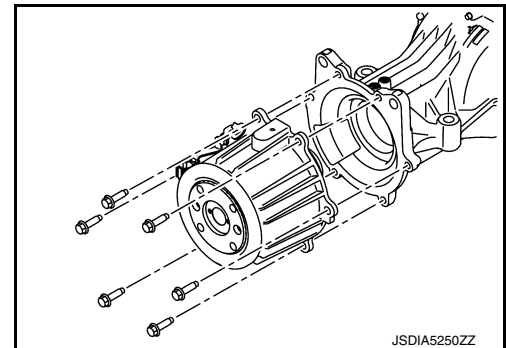

5. Remove connector bracket ① from electric controlled coupling.

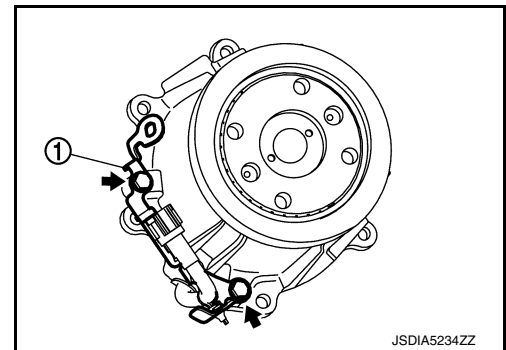

6. Separate band clip and connector clip from connector bracket.

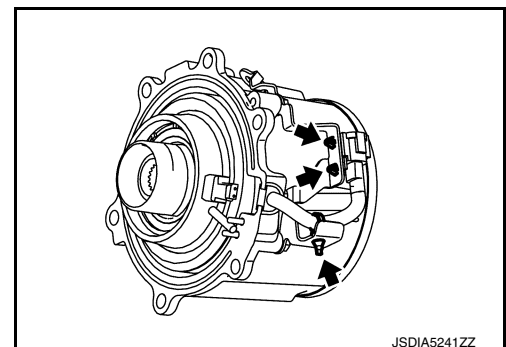

ASSEMBLY

ELECTRIC CONTROLLED COUPLING

< UNIT DISASSEMBLY AND ASSEMBLY >

[REAR FINAL DRIVE: R145]

1. Install connector bracket to electric controlled coupling.
 - For tightening torque, refer to [DLN-119, "Exploded View"](#).
2. Join AWD solenoid harness with band clip and connector clip.
3. Install drive pinion oil seal to the inside of gear carrier. Refer to [DLN-135, "Disassembly and Assembly"](#).

CAUTION:

When removing electric controlled coupling, replace drive pinion oil seal.

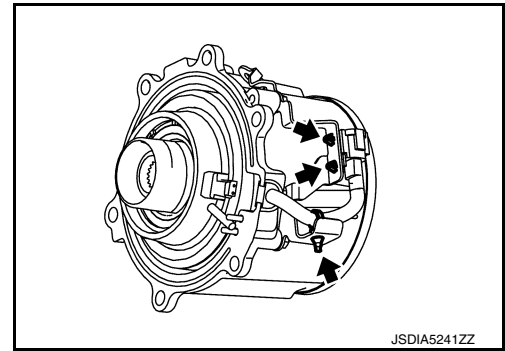

4. Install wave spring ① to the inside of gear carrier.

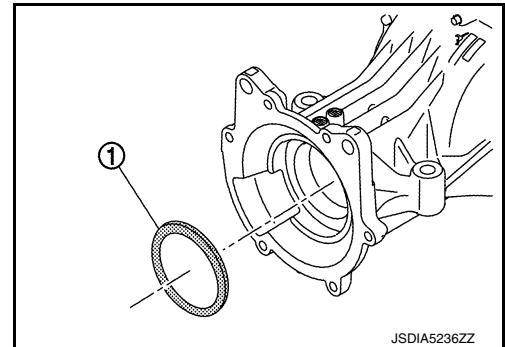

5. Apply liquid gasket to mating surface of electric controlled coupling assembly.
 - For applying liquid gasket, refer to [DLN-119, "Exploded View"](#).

CAUTION:

- Remove old gasket adhering to the mounting surfaces. Also remove any moisture, oil, or foreign material adhering to the mounting surfaces.
- The width of sealant bead is approximately 3 mm (0.12 in). Apply sealant evenly.

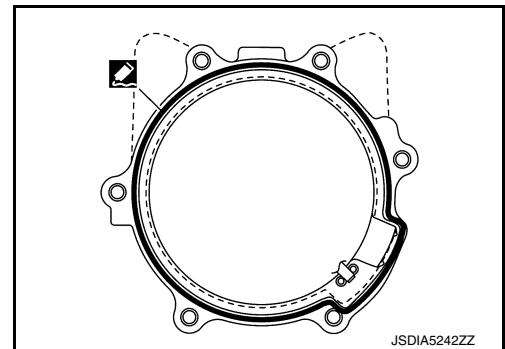

6. Match electric controlled coupling assembly ① to spline of drive pinion, then install it to final drive assembly ②.

CAUTION:

Be careful not to damage drive pinion oil seal.

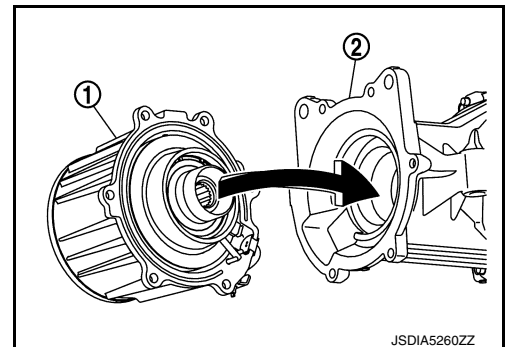

A
B
C
DLN
E
F
G
H
I
J
K
L
M
N
O
P

ELECTRIC CONTROLLED COUPLING

< UNIT DISASSEMBLY AND ASSEMBLY >

[REAR FINAL DRIVE: R145]

7. Temporarily tighten reamer bolts ① to the positions shown in the figure.
8. Tighten reamer bolts and electric controlled coupling assembly mounting bolts to the specified torque.
 - For tightening torque, refer to [DLN-119, "Exploded View"](#).

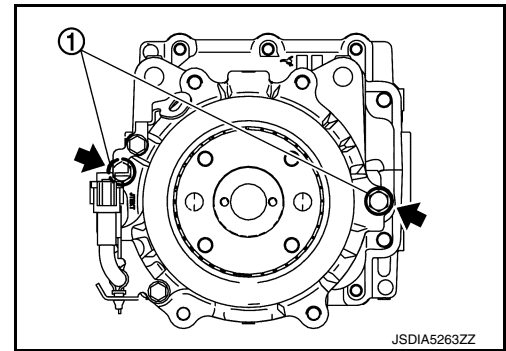

9. Install stud bolts ①.

⇐ : Electric controlled coupling side

Thread length

A : Long

B : Short

CAUTION:

- Never reuse stud bolt.
- Screw long thread side of stud bolt to electric controlled coupling.
- Screw the stud bolt until the stop by applying a torque of 15 N·m (1.5 kg-m, 11 ft-lb) $\pm 20\%$.
- After installing stud bolt, the length of the protrusion from electric controlled coupling must be 19.8 mm (0.780 in) ± 1.4 mm (0.055 in).

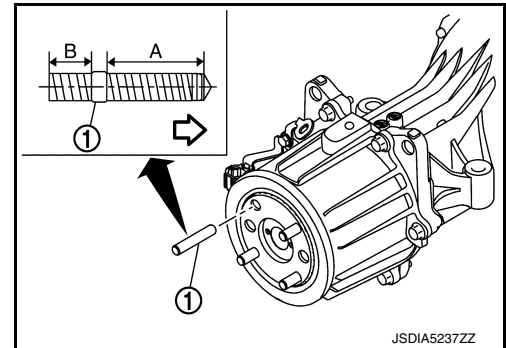

DIFFERENTIAL ASSEMBLY

< UNIT DISASSEMBLY AND ASSEMBLY >

[REAR FINAL DRIVE: R145]

DIFFERENTIAL ASSEMBLY

Exploded View

INFOID:000000012892972

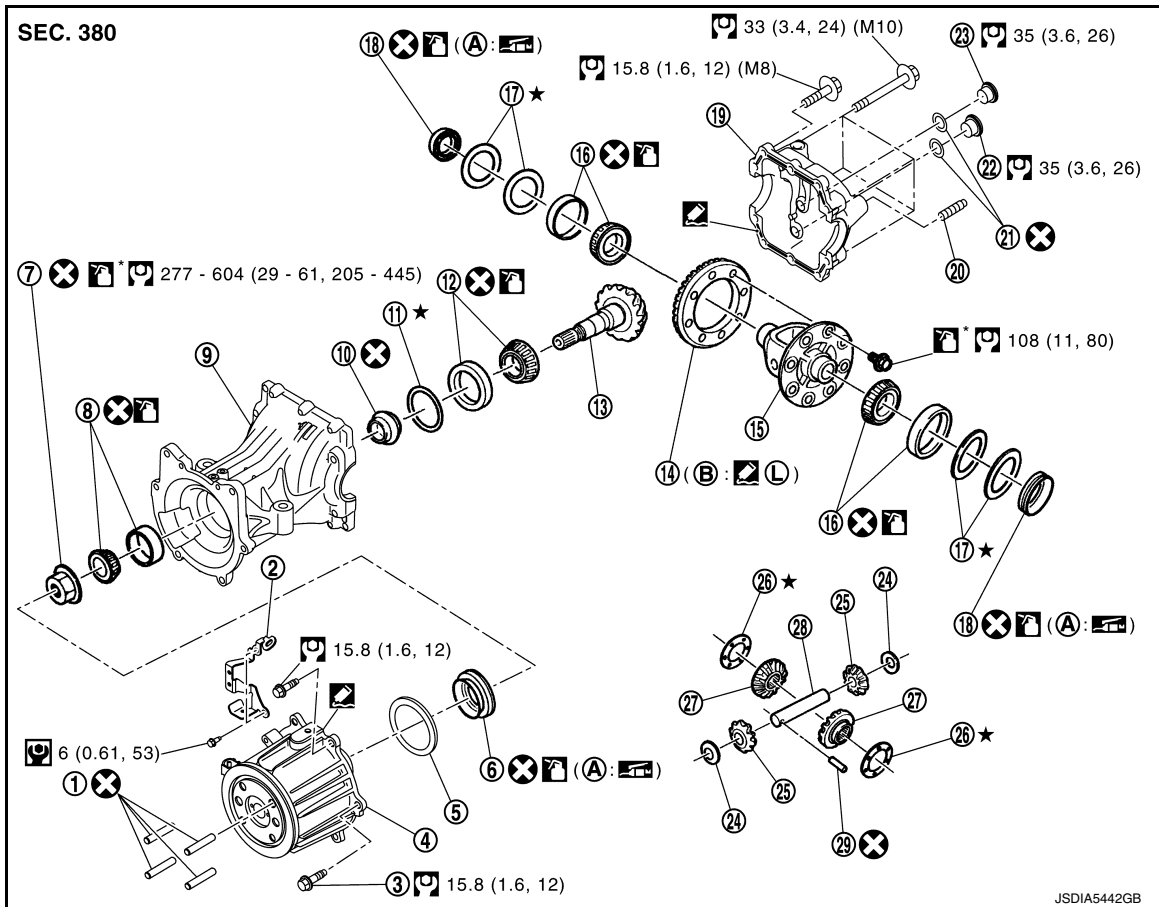

- | | | |
|---|-------------------------------|-----------------------------|
| ① Stud bolt | ② Connector bracket | ③ Reamer bolt |
| ④ Electric controlled coupling assembly | ⑤ Wave spring | ⑥ Drive pinion oil seal |
| ⑦ Drive pinion lock nut | ⑧ Pinion front bearing | ⑨ Gear carrier |
| ⑩ Collapsible spacer | ⑪ Drive pinion adjusting shim | ⑫ Pinion rear bearing |
| ⑬ Drive pinion | ⑭ Drive gear | ⑮ Differential case |
| ⑯ Side bearing | ⑰ Side bearing adjusting shim | ⑱ Side oil seal |
| ⑲ Rear cover | ⑳ Stud bolt | ㉑ Gasket |
| ㉒ Drain plug | ㉓ Filler plug | ㉔ Pinion mate thrust washer |
| ㉕ Pinion mate gear | ㉖ Side gear thrust washer | ㉗ Side gear |
| ㉘ Pinion mate shaft | ㉙ Lock pin | |
| (A) Oil seal lip | (B) Screw hole | |

: N·m (kg-m, in-lb)

: N·m (kg-m, ft-lb)

: Always replace after every disassembly.

★: Select with proper thickness.

: Apply gear oil.

: Apply anti-corrosion oil.

: Apply multi purpose grease.

A
B
C
DLN
E
F
G
H
I
J
K
L
M
N
O
P

DIFFERENTIAL ASSEMBLY

< UNIT DISASSEMBLY AND ASSEMBLY >

[REAR FINAL DRIVE: R145]

: Apply Genuine Silicone RTV or equivalent. Refer to [GI-22. "Recommended Chemical Products and Sealants"](#).

: Apply Genuine High Strength Thread Locking Sealant or equivalent. Refer to [GI-22. "Recommended Chemical Products and Sealants"](#).

Disassembly and Assembly

INFOID:000000012892973

DISASSEMBLY

1. Remove drain plug, filler plug and gaskets.
2. Remove the side oil seal, using oil seal remover (commercial service tool).

CAUTION:

Never damage gear carrier and rear cover.

3. Remove rear cover mounting bolts.

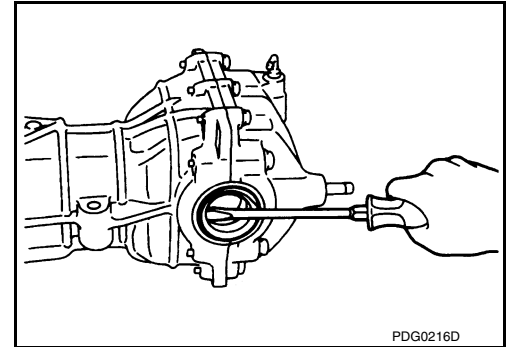

4. Set drifts (A and B) to the right and left side bearing adjusting shims individually. Press differential assembly with side bearing to remove gear carrier assembly and rear cover assembly.

A : Drift [SST: KV40100610 (J-26089)]

B : Drift [SST: KV40100610 (J-26089)]

CAUTION:

The pressure shall be as low as possible to remove gear carrier assembly and rear cover assembly. The maximum pressure shall be 10 kN (1 ton, 1.0 Imp ton).

NOTE:

Differential assembly, side bearings, and adjusting washers are compressed and integrated in gear carrier and rear cover.

5. Remove stud bolt from rear cover.

NOTE:

It is not necessary to remove stud bolt except when it is replaced.

6. Remove side bearing adjusting shims and side bearing outer races.

CAUTION:

Mark the side bearing adjusting shims so that the original mounting positions (right/left) can be identified later.

7. Remove side bearing inner races, using adaptor (A), separator (B) and puller (C).

A : Adaptor [SST: ST33052000 (—)]

B : Separator (commercial service tool)

C : Puller (commercial service tool)

CAUTION:

- To prevent damage to the side bearing and drive gear, place copper plates between these parts and vise.
- It is not necessary to remove side bearing inner race except when it is replaced.

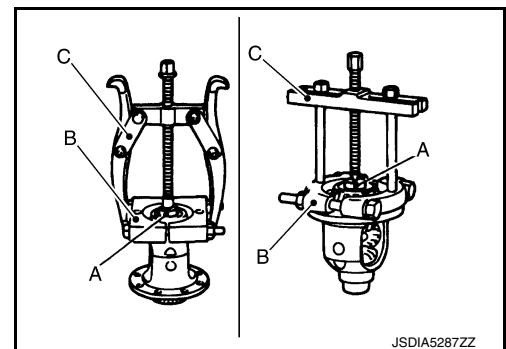
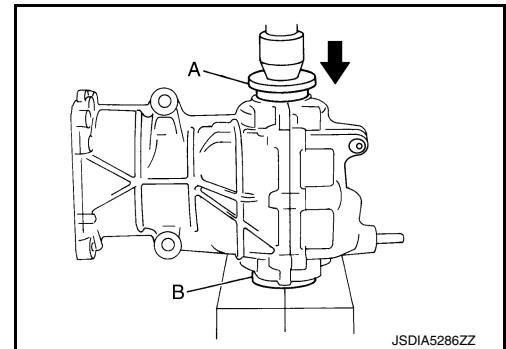

DIFFERENTIAL ASSEMBLY

< UNIT DISASSEMBLY AND ASSEMBLY >

[REAR FINAL DRIVE: R145]

8. For proper reinstallation, paint matching marks (A) on one differential assembly and drive gear.

CAUTION:

For matching marks, use paint. Never damage differential assembly and drive gear.

9. Remove drive gear mounting bolts and then remove drive gear from differential assembly.

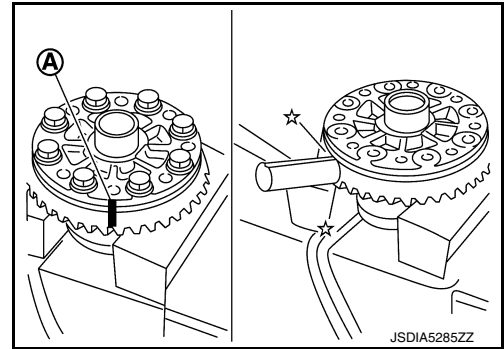

10. Remove lock pin of pinion mate shaft, using the pin punch (commercial service tool).

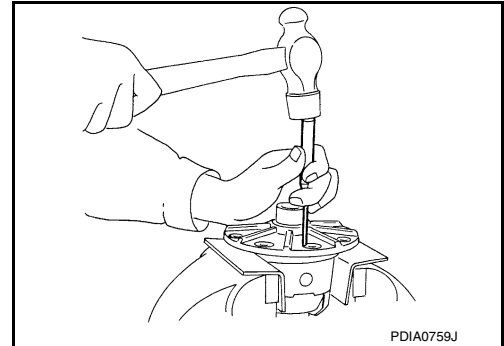

11. Remove pinion mate shaft.

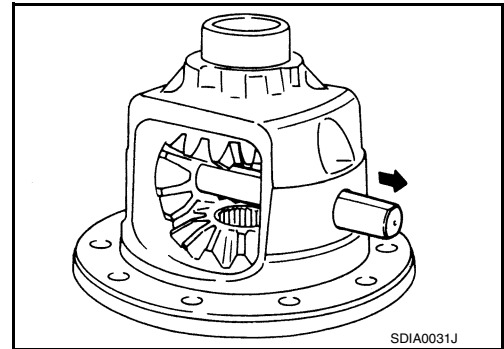

12. Remove pinion mate gears, pinion mate thrust washers, side gears, side gear thrust washers from differential case.

13. Perform inspection after disassembly. Refer to [DLN-133](#), "[Inspection](#)".

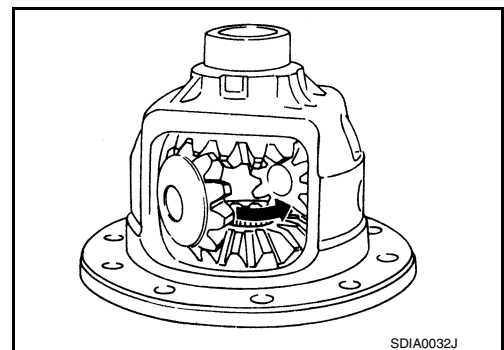

ASSEMBLY

A
B
C
DLN
E
F
G
H
I
J
K
L
M
N
O
P

DIFFERENTIAL ASSEMBLY

< UNIT DISASSEMBLY AND ASSEMBLY >

[REAR FINAL DRIVE: R145]

1. Install side gear thrust washers with the same thickness as the ones installed prior to disassembly or reinstall the old ones on the side gears.
2. Install side gears and side gear thrust washers into differential case.

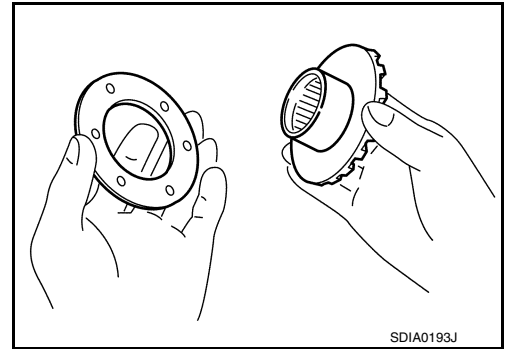

3. Align 2 pinion mate gears in diagonally opposite positions, then rotate and install them into differential case after installing thrust washer to pinion mate gear.

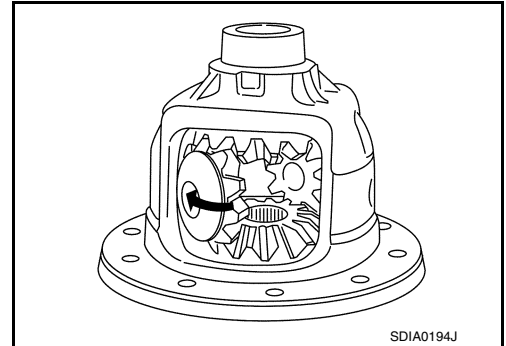

4. Align the lock pin holes on differential case with pinion mate shaft, and install pinion mate shaft.

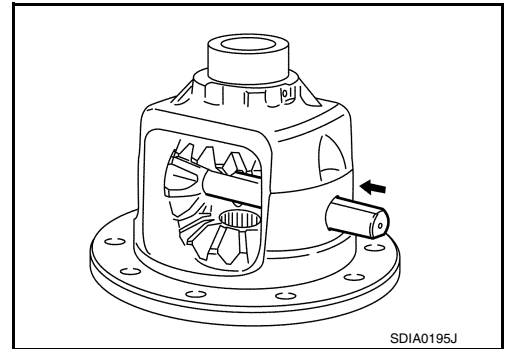

5. Measure side gear end play. If necessary, select the appropriate side gear thrust washers.
 - a. Place differential assembly straight up so that side gear to be measured comes upward.

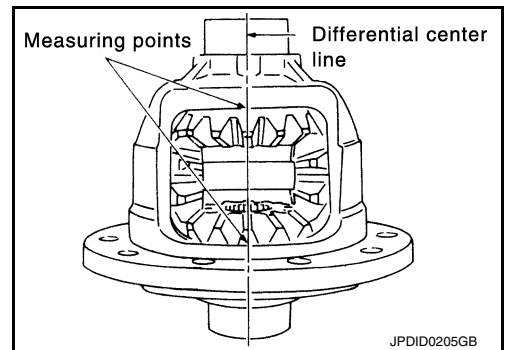

DIFFERENTIAL ASSEMBLY

< UNIT DISASSEMBLY AND ASSEMBLY >

[REAR FINAL DRIVE: R145]

- b. Using feeler gauge, measure the clearance between side gear back and differential case at 3 different points, while rotating side gear. Average the 3 readings, and then measure the clearance of the other side as well.

Side gear back clearance : Refer to [DLN-140, "Differential Side Gear Clearance"](#).

CAUTION:

To prevent side gear from tilting, insert feeler gauges with the same thickness from both sides.

- If the back clearance is outside the specification, use a thicker/thinner side gear thrust washer to adjust. For selecting thrust washer, refer to the latest parts information.

When the back clearance is large : Use a thicker thrust washer.

When the back clearance is small : Use a thinner thrust washer.

CAUTION:

Select a side gear thrust washer for right and left individually.

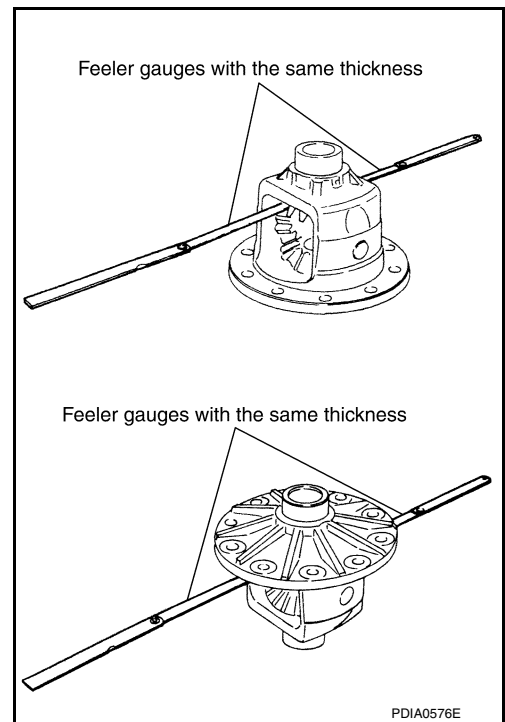

6. Drive a lock pin into pinion mate shaft, using the pin punch (commercial service tool).

CAUTION:

Never reuse lock pin.

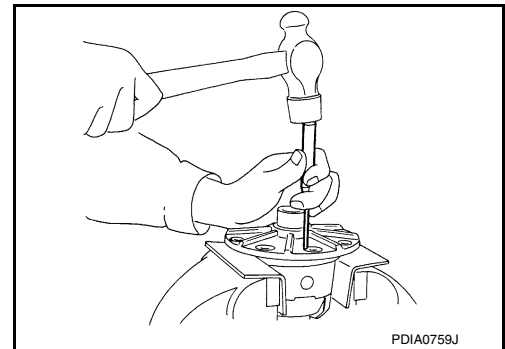

7. Press side bearing inner races to differential assembly, using the drifts (A and B).

A : Drift [SST: KV40105020 (—)]

B : Drift [SST: KV40105020 (—)]

CAUTION:

- Never reuse side bearing inner race.
- Apply gear oil to side bearing.

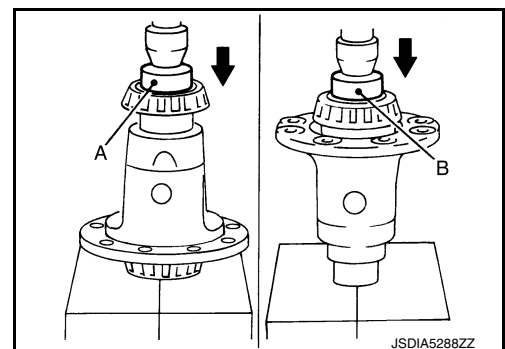

8. Apply thread locking sealant into the thread hole of drive gear.
- For applying thread locking sealant, refer to [DLN-123, "Exploded View"](#).

CAUTION:

Clean and degrease drive gear back and threaded holes sufficiently.

9. Install the drive gear to differential assembly.

CAUTION:

Align the matching mark of differential assembly and drive gear.

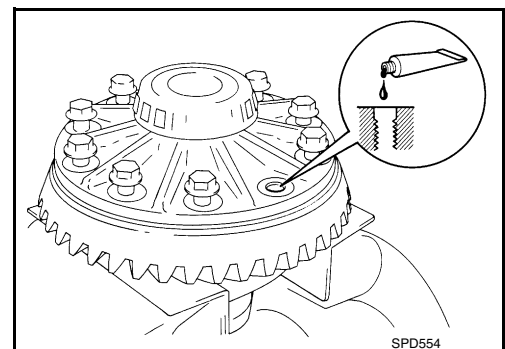

A
B
C
DLN
E
F
G
H
I
J
K
L
M
N
O
P

DIFFERENTIAL ASSEMBLY

< UNIT DISASSEMBLY AND ASSEMBLY >

[REAR FINAL DRIVE: R145]

10. Tighten the bolts in a crisscross fashion to the specified torque.
- For tightening torque, refer to [DLN-123, "Exploded View"](#).

CAUTION:

Apply anti-corrosion oil to the thread and seat of mounting bolts.

11. Assemble side bearing outer races to inner races.

CAUTION:

- Never reuse side bearing outer race.
- Apply gear oil to side bearing.

12. Install new side bearing adjusting shims (2 pieces for one side) with the same thickness as the ones installed prior to disassembly or re-install the old ones, on side bearing outer race of differential assembly.

If side bearing adjusting shims have been already selected, use them.

13. Set the drifts (A and B) to the right and left side bearing adjusting shims individually. Compress differential assembly and side bearing to gear carrier assembly to install differential assembly.

A : Drift [KV40100610 (J-26089)]

B : Drift [KV40100610 (J-26089)]

CAUTION:

- The drift shall be placed on the center of the adjusting shims.
- The pressure shall be as low as possible to install differential assembly into gear carrier assembly. The maximum pressure shall be 10 kN (1 ton, 1.1 US ton, 1.0 Imp ton).
- If the adjusting shims are installed by tapping, the gear carrier may be damaged. Avoid tapping.

14. Install dummy cover set, check and adjust drive gear runout, tooth contact, backlash, and total preload torque. Refer to [DLN-129, "Adjustment"](#).

15. Remove dummy cover set.

16. Install stud bolt to rear cover.

CAUTION:

Screw the stud bolt until the thread becomes invisible by applying a torque of 20 N·m (2.0 kg·m, 15 ft·lb) or less.

17. Apply liquid gasket to mating surface of rear cover.

- For applying liquid gasket, refer to [DLN-123, "Exploded View"](#).

CAUTION:

- Remove old gasket adhering to the mounting surfaces. Also remove any moisture, oil, or foreign material adhering to the mounting surfaces.
- The width of sealant bead is approximately 3 mm (0.12 in). Apply sealant evenly.

18. Set the drifts (A and B) to the right and left side bearing adjusting shims individually. Compress differential assembly and side bearing to install rear cover.

A : Drift [SST: KV40100610 (J-26089)]

B : Drift [SST: KV40100610 (J-26089)]

CAUTION:

- The drift shall be placed on the center of the adjusting shims.

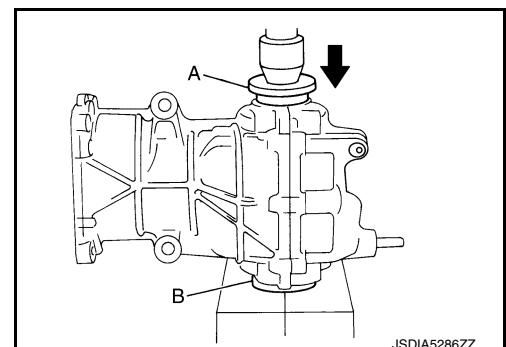
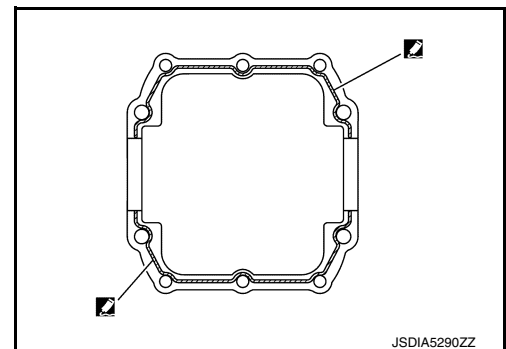
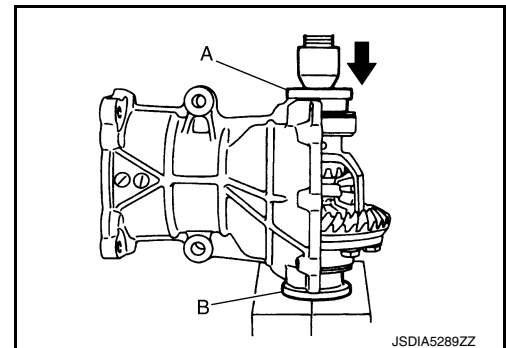
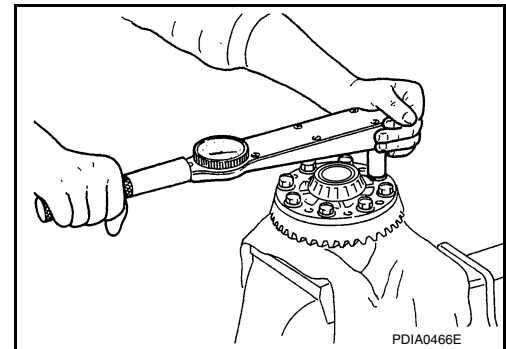

DIFFERENTIAL ASSEMBLY

< UNIT DISASSEMBLY AND ASSEMBLY >

[REAR FINAL DRIVE: R145]

- The pressure shall be as low as possible to install differential assembly into gear carrier assembly. The maximum pressure shall be 10 kN (1 ton, 1.1 US ton, 1.0 Imp ton).
 - If the adjusting shims are installed by tapping, the gear carrier may be damaged. Avoid tapping.
19. Tighten rear cover mounting bolts to the specified torque.
 - For tightening torque, refer to [DLN-123, "Exploded View"](#).
 20. Using the drift (A) [SST: KV38100200 (J-26233)], drive side oil seals until it becomes flush with the gear carrier end.
CAUTION:
 - Never reuse oil seal.
 - When installing, never incline oil seal.
 - Apply multi-purpose grease onto oil seal lips, and gear oil onto the circumference of oil seal.
 21. Check total preload torque. Refer to [DLN-129, "Adjustment"](#).

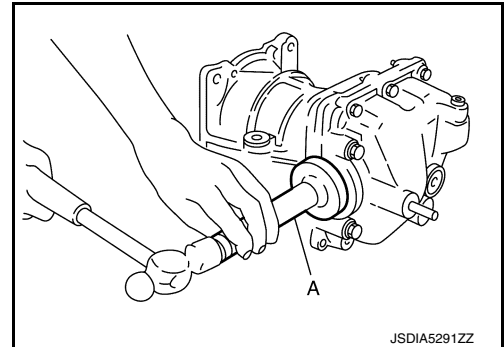

INFOID:000000012892974

Adjustment

TOTAL PRELOAD TORQUE

1. Remove electric controlled coupling assembly. Refer to [DLN-120, "Disassembly and Assembly"](#).
2. Rotate drive pinion back and forth 2 to 3 times to check for unusual noise and rotation malfunction.
3. Rotate drive pinion at least 20 times to check for smooth operation of the bearing.
4. Fit drive pinion socket onto drive pinion spline. Measure the total preload, using the preload gauge and drive pinion socket.

- A : Drive pinion socket [SST: KV38109500 (—)]
B : Preload gauge [SST: ST3127S000 (J-25765-A)]

Total preload torque : Refer to [DLN-140, "Preload Torque"](#).

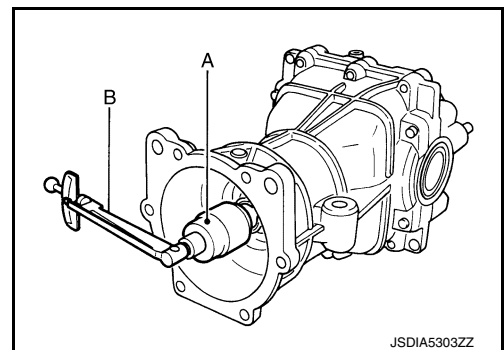

NOTE:

Total preload torque = Pinion bearing torque + Side bearing torque

- If measured value is out of the specification, disassemble it to check and adjust each part. Adjust the pinion bearing preload and side bearing preload.
Adjust the pinion bearing preload first, then adjust the side bearing preload.

When the preload torque is large

On pinion bearings: Replace the collapsible spacer.

On side bearings: Use thinner side bearing adjusting shims. For selecting adjusting shim, refer to the latest parts information.

When the preload is small

On pinion bearings: Tighten the drive pinion nut.

On side bearings: Use thicker side bearing adjusting shims. For selecting adjusting shim, refer to the latest parts information.

DRIVE GEAR RUNOUT

1. Remove rear cover. Refer to [DLN-124, "Disassembly and Assembly"](#).
2. Following the procedure below, install a dummy cover set [SST: KV381086S1 (—)] to gear carrier.
 - a. Set dummy cover shims [SST: KV38108630 (—)] to the right and left side bearing adjusting shims.

DIFFERENTIAL ASSEMBLY

< UNIT DISASSEMBLY AND ASSEMBLY >

[REAR FINAL DRIVE: R145]

- b. Temporarily tighten dummy cover [SST: KV38108610 (—)] to gear carrier.
- c. Position dummy cover spacers [SST: KV38108621 (—)] to dummy cover [SST: KV38108610 (—)].
- d. Tighten rear cover mounting bolts to the specified torque. Refer to [DLN-123, "Exploded View"](#).
- e. Tighten dummy cover spacer mounting bolts evenly to the specified torque.

 : 5.9 N·m (0.6 kg-m, 52 in-lb)

3. Fit a dial indicator (A) to the drive gear back face.

B : Dummy cover set [SST: KV381086S1 (—)]

4. Rotate the drive gear to measure runout.

Drive gear back face runout : Refer to [DLN-140, "Drive Gear Runout"](#).

- If the runout is outside of the repair limit, check drive gear assembly condition; foreign material may be caught between drive gear and differential case, or differential case or drive gear may be deformed, etc.

CAUTION:

Replace drive gear and drive pinion as a set.

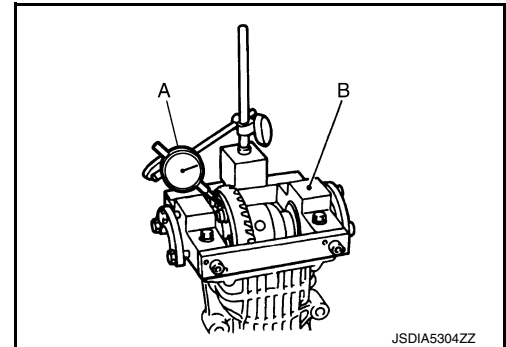

TOOTH CONTACT

1. Remove rear cover. Refer to [DLN-124, "Disassembly and Assembly"](#).
2. Following the procedure below, install a dummy cover set [SST: KV381086S1 (—)] to gear carrier.
 - a. Set dummy cover shims [SST: KV38108630 (—)] to the right and left side bearing adjusting shims.
 - b. Temporarily tighten dummy cover [SST: KV38108610 (—)] to gear carrier.
 - c. Position dummy cover spacers [SST: KV38108621 (—)] to dummy cover [SST: KV38108610 (—)].
 - d. Tighten rear cover mounting bolts to the specified torque. Refer to [DLN-123, "Exploded View"](#).
 - e. Tighten dummy cover spacer mounting bolts evenly to the specified torque.

 : 5.9 N·m (0.6 kg-m, 52 in-lb)

3. Apply red lead or equivalent to drive gear.

A : Dummy cover set [SST: KV381086S1 (—)]

CAUTION:

Apply red lead or equivalent to both the faces of 3 to 4 gears at 4 locations evenly spaced on drive gear.

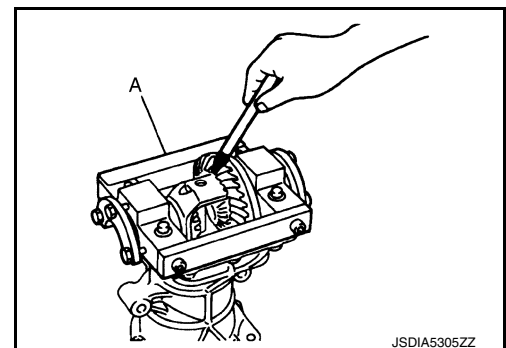

DIFFERENTIAL ASSEMBLY

< UNIT DISASSEMBLY AND ASSEMBLY >

[REAR FINAL DRIVE: R145]

4. Rotate drive gear back and forth several times, check drive pinion gear to drive gear tooth contact.

CAUTION:

Check tooth contact on drive side and reverse side.

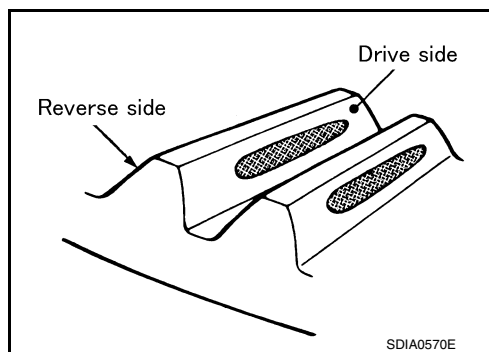

Tooth Contact Judgment Guide

Tooth contact condition		Drive pinion adjusting shim selection value [mm (in)]	Adjustment (Yes/No)	Possible cause
Drive side	Back side			
Heel side Toe side	Toe side Heel side	↑ Thicker	Yes	Occurrence of noise and scoring sound in all speed ranges.
 Heel side	 Toe side			
 Toe side	 Heel side	↓ Thinner	No	-
 Heel side	 Toe side			
 Toe side	 Heel side	0	No	-
 Heel side	 Toe side			
 Toe side	 Heel side	↓ Thinner	Yes	Occurrence of noise at constant speed and decreasing speed.
 Heel side	 Toe side			
 Toe side	 Heel side	↓ Thinner	Yes	Occurrence of noise and scoring sound in all speed ranges.
 Heel side	 Toe side			
 Toe side	 Heel side	↓ Thinner	Yes	Occurrence of noise and scoring sound in all speed ranges.
 Heel side	 Toe side			

SDIA2549E

5. If tooth contact is improperly adjusted, follow the procedure below to adjust the pinion height (dimension X).

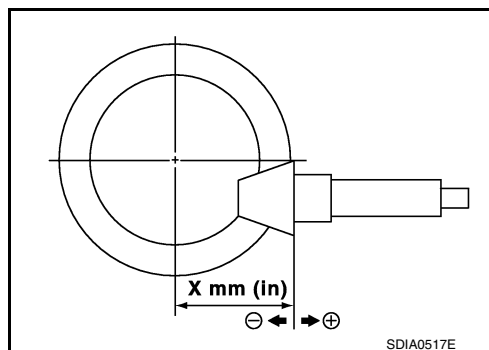

DIFFERENTIAL ASSEMBLY

< UNIT DISASSEMBLY AND ASSEMBLY >

[REAR FINAL DRIVE: R145]

- If the tooth contact is near the face (face contact), or near the heel (heel contact), thicken drive pinion gear adjusting shim to move drive pinion closer to drive gear.
For selecting adjusting shim, refer to the latest parts information.

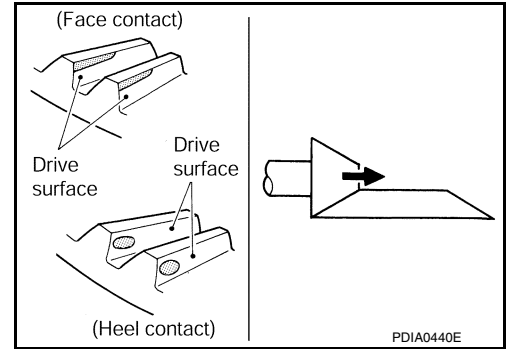

- If the tooth contact is near the flank (flank contact), or near the toe (toe contact), thin drive pinion gear adjusting shim to move drive pinion farther from drive gear.
For selecting adjusting shim, refer to the latest parts information.

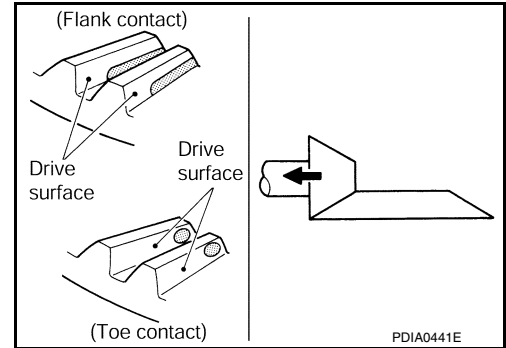

BACKLASH

- Remove rear cover. Refer to [DLN-124, "Disassembly and Assembly"](#).
- Following the procedure below, install a dummy cover set [SST: KV381086S1 (—)] to gear carrier.
 - Set dummy cover shims [SST: KV38108630 (—)] to the right and left side bearing adjusting shims.
 - Temporarily tighten dummy cover [SST: KV38108610 (—)] to gear carrier.
 - Position dummy cover spacers [SST: KV38108621 (—)] to dummy cover [SST: KV38108610 (—)].
 - Tighten rear cover mounting bolts to the specified torque. Refer to [DLN-123, "Exploded View"](#).
 - Tighten dummy cover spacer mounting bolts evenly to the specified torque.

: 5.9 N·m (0.6 kg-m, 52 in-lb)

- Fit a dial indicator (A) to the drive gear face to measure the backlash.

B : Dummy cover set [SST: KV381086S1 (—)]

Backlash : Refer to [DLN-140, "Backlash"](#).

- If the backlash is outside of the specified value, change the thickness of side bearing adjusting shims.

When the backlash is large:

Make drive gear back adjusting shims thicker, and drive gear front adjusting shims thinner. For selecting adjusting shim, refer to the latest parts information.

When the backlash is small:

Make drive gear back adjusting shims thinner, and drive gear front adjusting shims thicker. For selecting adjusting shim, refer to the latest parts information.

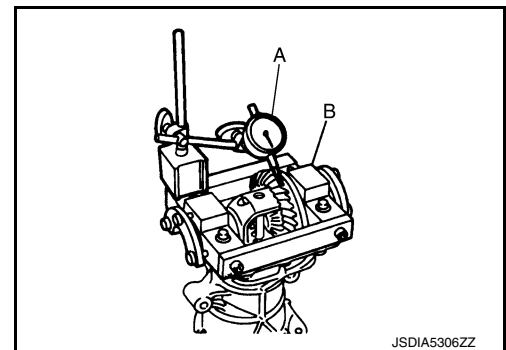

DIFFERENTIAL ASSEMBLY

< UNIT DISASSEMBLY AND ASSEMBLY >

[REAR FINAL DRIVE: R145]

Inspection

INFOID:000000012892975

INSPECTION AFTER DISASSEMBLY

Drive Gear and Drive Pinion

- Clean up the disassembled parts.
- If the gear teeth never mesh or line-up correctly, determine the cause and adjust or replace as necessary.
- If the gears are worn, cracked, damaged, pitted or chipped (by friction) noticeably, replace with new drive gear and drive pinion as a set.

Bearing

- Clean up the disassembled parts.
- If any chipped (by friction), pitted, worn, rusted or scratched marks, or unusual noise from the bearing is observed, replace as a bearing assembly (as a new set).

Oil Seal

- Whenever disassembled, replace.
- If wear, deterioration of adherence (sealing force lips), or damage is detected on the lips, replace them.

Differential Assembly

DIFFERENTIAL CASE

- Clean up the disassembled parts.
- If any wear or crack on the contact sides of the differential case is found, replace.

SIDE GEAR AND PINION MATE GEAR

- Clean up the disassembled parts.
- If any cracks or damage on the surface of the tooth is found, replace.
- If any worn or chipped mark on the contact sides of the thrust washer is found, replace.

SIDE GEAR THRUST WASHER AND PINION MATE THRUST WASHER

- Clean up the disassembled parts.
- If it is chipped (by friction), damaged, or unusually worn, replace.

A

B

C

DLN

E

F

G

H

I

J

K

L

M

N

O

P

DRIVE PINION

< UNIT DISASSEMBLY AND ASSEMBLY >

[REAR FINAL DRIVE: R145]

DRIVE PINION

Exploded View

INFOID:000000012892976

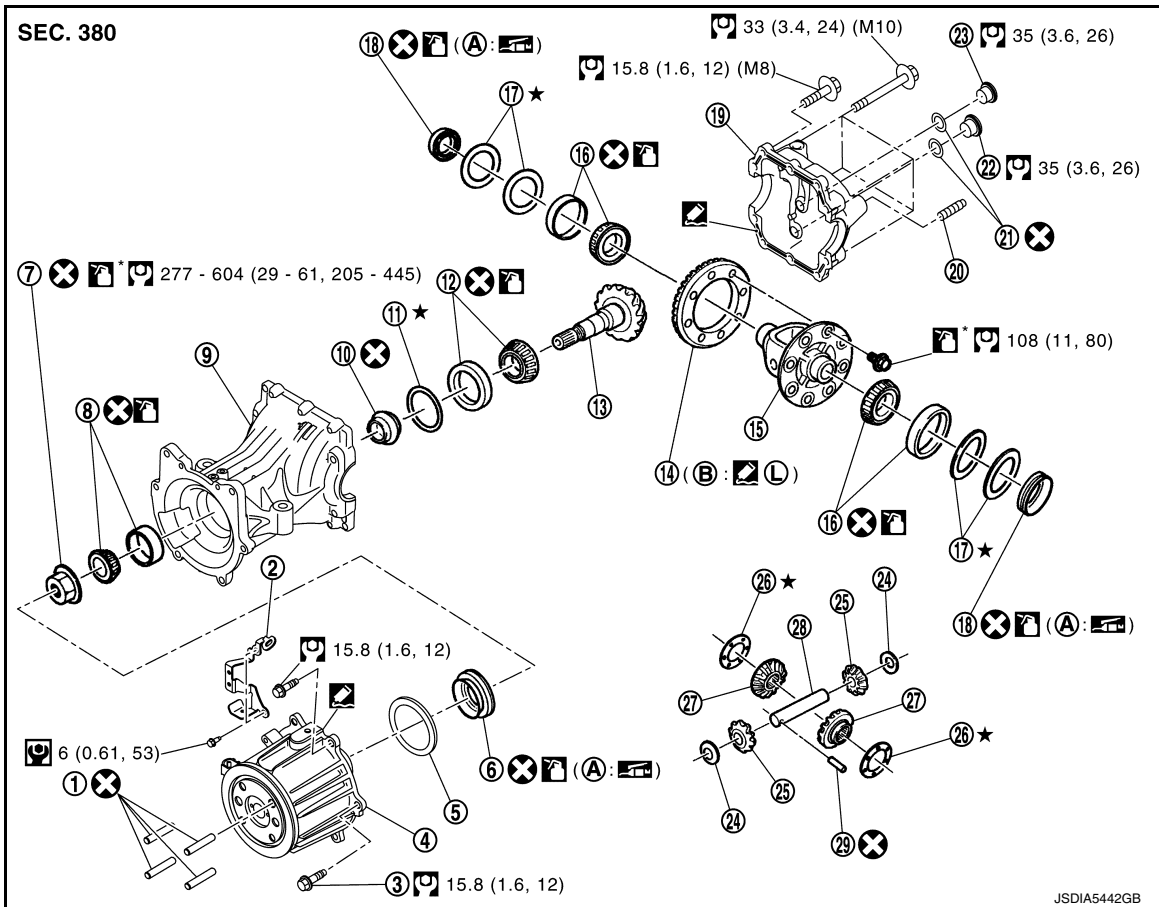

- | | | |
|---|-------------------------------|-----------------------------|
| ① Stud bolt | ② Connector bracket | ③ Reamer bolt |
| ④ Electric controlled coupling assembly | ⑤ Wave spring | ⑥ Drive pinion oil seal |
| ⑦ Drive pinion lock nut | ⑧ Pinion front bearing | ⑨ Gear carrier |
| ⑩ Collapsible spacer | ⑪ Drive pinion adjusting shim | ⑫ Pinion rear bearing |
| ⑬ Drive pinion | ⑭ Drive gear | ⑮ Differential case |
| ⑯ Side bearing | ⑰ Side bearing adjusting shim | ⑱ Side oil seal |
| ⑲ Rear cover | ⑳ Stud bolt | ㉑ Gasket |
| ㉒ Drain plug | ㉓ Filler plug | ㉔ Pinion mate thrust washer |
| ㉕ Pinion mate gear | ㉖ Side gear thrust washer | ㉗ Side gear |
| ㉘ Pinion mate shaft | ㉙ Lock pin | |
| (A) Oil seal lip | (B) Screw hole | |

: N·m (kg-m, in-lb)

: N·m (kg-m, ft-lb)

: Always replace after every disassembly.

★: Select with proper thickness.

: Apply gear oil.

: Apply anti-corrosion oil.



: Apply multi purpose grease.

DRIVE PINION

< UNIT DISASSEMBLY AND ASSEMBLY >

[REAR FINAL DRIVE: R145]

 Apply Genuine Silicone RTV or equivalent. Refer to [GI-22. "Recommended Chemical Products and Sealants"](#).

  Apply Genuine High Strength Thread Locking Sealant or equivalent. Refer to [GI-22. "Recommended Chemical Products and Sealants"](#).

Disassembly and Assembly

INFOID:000000012892977

DISASSEMBLY

1. Remove electric controlled coupling assembly. Refer to [DLN-120. "Disassembly and Assembly"](#).
2. Remove differential assembly. Refer to [DLN-124. "Disassembly and Assembly"](#).
3. Remove drive pinion oil seal, using oil seal remover (commercial service tool).
4. Fit drive pinion socket (A) onto drive pinion spline. Remove drive pinion lock nut, using the pinion nut wrench (B).

A : Drive pinion socket [SST: KV38109500 (—)]

B : Pinion nut wrench [SST: KV38109400 (—)]

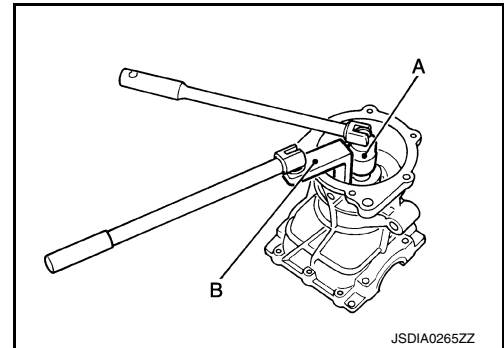

5. Press drive pinion assembly out of gear carrier.

CAUTION:

Never drop drive pinion assembly.

6. Remove pinion front bearing inner race.
7. Remove collapsible spacer.

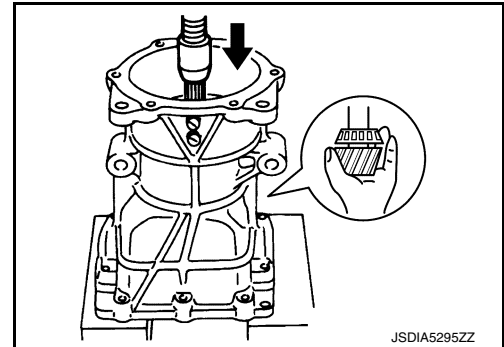

8. Remove pinion rear bearing inner race from drive pinion, using the separator (A) and the puller (B).

A : Separator (commercial service tool)

B : Puller (commercial service tool)

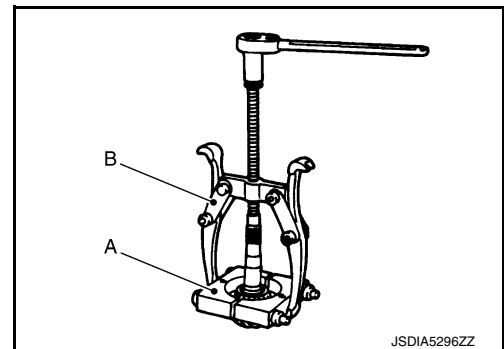

9. Using a brass rod or equivalent (A), tap pinion front bearing outer race evenly from the 2 cutouts on gear carrier and remove pinion front bearing outer race.

CAUTION:

Be careful not to damage gear carrier.

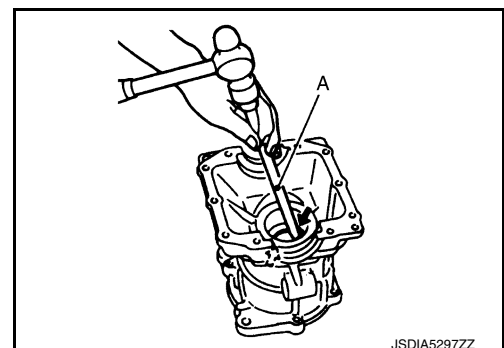

A
B
C
DLN
E
F
G
H
I
J
K
L
M
N
O
P

DRIVE PINION

< UNIT DISASSEMBLY AND ASSEMBLY >

[REAR FINAL DRIVE: R145]

10. Using a brass rod or equivalent (A), tap drive pinion adjusting shim evenly from the 2 cutouts on gear carrier and remove drive pinion adjusting shim and pinion rear bearing outer race.

CAUTION:

Be careful not to damage gear carrier.

11. Perform inspection after disassembly. Refer to [DLN-139](#). "[Inspection](#)".

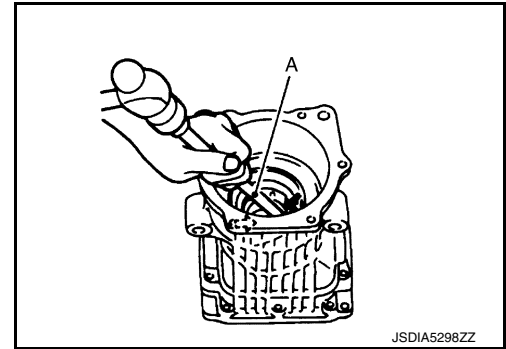

ASSEMBLY

1. Install a drive pinion adjusting shim of the same thickness as was installed prior to disassembly. Press pinion rear bearing outer race into gear carrier, using the drift (A) [SST: ST33200000 (J-26082)].

CAUTION:

- At first, using a hammer, tap bearing outer race until it becomes flush to gear carrier.
- Never reuse pinion rear bearing outer race.

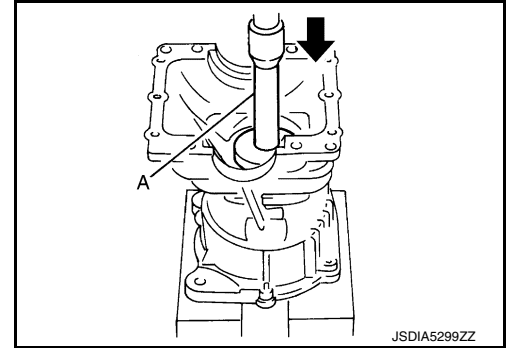

2. Press pinion front bearing outer race into gear carrier, using the drift (A) [SST: ST33230000 (J-25805-01)].

CAUTION:

- At first, using a hammer, tap bearing outer race until it becomes flush to gear carrier.
- Never reuse pinion front bearing outer race.

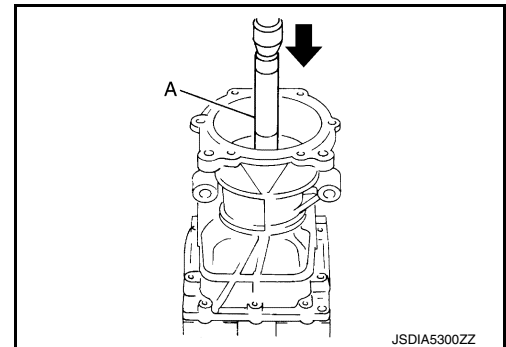

3. Press pinion rear bearing inner race to drive pinion, using the drift (A) [SST: ST23860000 (—)].

CAUTION:

Never reuse pinion rear bearing inner race.

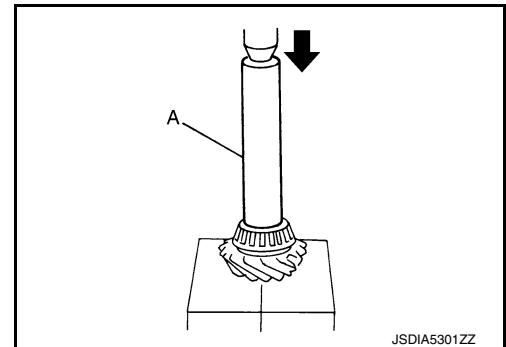

4. Check and adjust the tooth contact and back lash of drive gear and drive pinion following the procedure below.

- a. Assemble drive pinion into gear carrier.

CAUTION:

- Never assemble collapsible spacer.
- Apply gear oil to pinion rear bearing.

- b. Assemble pinion front bearing inner race to drive pinion assembly.

CAUTION:

- Never reuse pinion front bearing inner race.
- Apply gear oil to pinion front bearing.

DRIVE PINION

< UNIT DISASSEMBLY AND ASSEMBLY >

[REAR FINAL DRIVE: R145]

- c. Using the drifts (A and C) and press stand (B), press pinion front bearing inner race to drive pinion as far as drive pinion lock nut can be tightened.

- A : Drift [SST: KV40100610 (J-26089)]
- B : Press stand [SST: ST38220000 (—)]
- C : Drift [SST: ST23860000 (—)]

- d. Temporarily tighten removed drive pinion lock nut to drive pinion.

NOTE:

Use removed drive pinion lock nut only for the preload measurement.

- e. Rotate drive pinion more than 20 times to adjust bearing.

- f. Fit the drive pinion socket (A) onto the drive pinion. Using the pinion nut wrench (B), tighten drive pinion lock nut holding drive pinion, while adjusting pinion bearing preload torque using preload gauge (C).

- A : Drive pinion socket [SST: KV38109500 (—)]
- B : Pinion nut wrench [SST: KV38109400 (—)]
- C : Preload gauge [SST: ST3127S000 (J-25765-A)]

Pinion bearing preload : Refer to [DLN-140, "Preload Torque"](#).

CAUTION:

Drive pinion lock nut is tightened with no collapsible spacer. Be careful not to overtighten it. While measuring the preload, tighten it by 5° to 10°.

- g. Install new side bearing adjusting shims (2 pieces for one side) with the same thickness or re-install the old ones to the same mounting position they were in prior to disassembly. Install differential assembly to gear carrier. Refer to [DLN-124, "Disassembly and Assembly"](#).

CAUTION:

Apply differential gear oil to the side bearings.

- h. Check and adjust tooth contact, drive gear to drive pinion backlash. Refer to [DLN-129, "Adjustment"](#).
- i. Remove differential assembly.
- j. Remove drive pinion assembly from gear carrier
- k. Remove drive pinion nut and press drive pinion assembly out of gear carrier.
- l. Remove pinion front bearing inner race.

5. Assemble collapsible spacer ① to drive pinion ②.

CAUTION:

- Be careful of the mounting direction of collapsible spacer.
- Never reuse collapsible spacer.

6. Assemble drive pinion into gear carrier.

CAUTION:

Apply gear oil to pinion rear bearing.

7. Assemble pinion front bearing inner race to drive pinion assembly.

CAUTION:

- Never reuse pinion front bearing inner race.
- Apply gear oil to pinion front bearing.

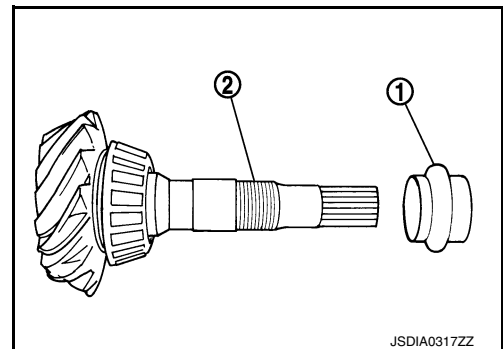
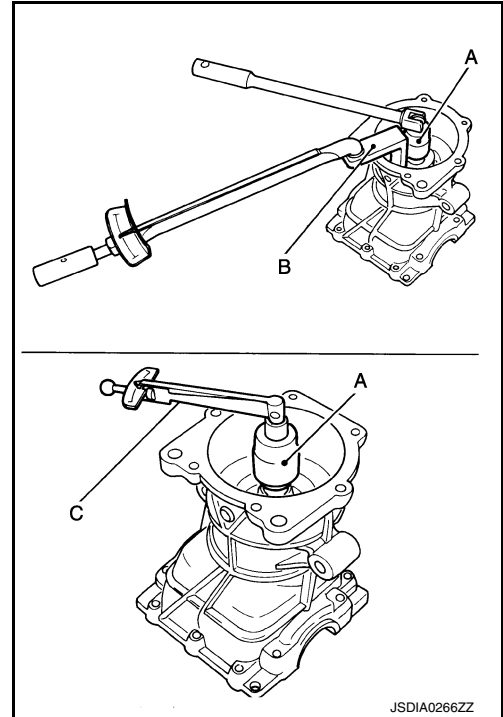
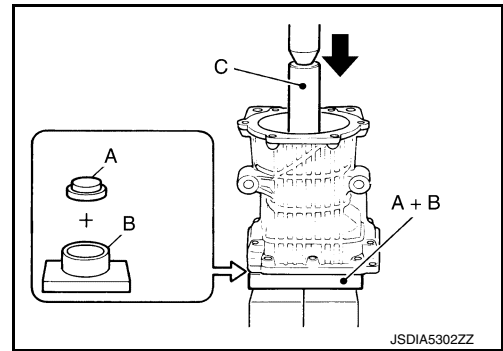

A
B
C
DLN

E
F
G
H
I
J
K

L
M

N
O
P

DRIVE PINION

< UNIT DISASSEMBLY AND ASSEMBLY >

[REAR FINAL DRIVE: R145]

8. Using the drifts (A and C) and press stand (B), press pinion front bearing inner race to drive pinion as far as drive pinion lock nut can be tightened.

- A : Drift [SST: KV40100610 (J-26089)]
 B : Press stand [SST: ST38220000 (—)]
 C : Drift [SST: ST23860000 (—)]

9. Apply anti-corrosion oil to the thread and seat of drive pinion lock nut, and temporarily tighten drive pinion lock nut to drive pinion.

CAUTION:

Never reuse drive pinion lock nut.

10. Fit the drive pinion socket (A) onto the drive pinion. While holding drive pinion, tighten drive pinion lock nut within the limits of specified torque so as to keep the pinion bearing preload within a standard values, using the pinion nut wrench (B) and the preload gauge (C).

- A : Drive pinion socket [SST: KV38109500 (—)]
 B : Pinion nut wrench [SST: KV38109400 (—)]
 C : Preload gauge [SST: ST3127S000 (J-25765-A)]

Drive pinion lock nut tightening torque : Refer to [DLN-134, "Exploded View"](#).

Pinion bearing preload : Refer to [DLN-140, "Preload Torque"](#).

CAUTION:

- Adjust the lower limit of the drive pinion lock nut tightening torque first.
- If the preload torque exceeds the specified value, replace collapsible spacer and tighten it again to adjust. Never loose n drive pinion lock nut to adjust the preload torque.
- After adjustment, rotate drive pinion back and forth 2 to 3 times to check for unusual noise, rotation malfunction, and other malfunctions.

11. Install differential assembly. Refer to [DLN-124, "Disassembly and Assembly"](#).

CAUTION:

Never install rear cover at this timing.

12. Check and adjust drive gear runout, tooth contact, and drive gear to drive pinion backlash. Refer to [DLN-129, "Adjustment"](#).

13. Remove dummy cover set, then install rear cover, and side oil seal. Refer to [DLN-124, "Disassembly and Assembly"](#).

14. Check total preload torque. Refer to [DLN-129, "Adjustment"](#).

15. Using the drift (A) [SST: ST35271000 (J-26091)], install drive pinion oil seal ① within the dimension (D) shown as follows.

D : 0.8 – 1.2 mm (0.031 – 0.047 in)

CAUTION:

- Never reuse oil seal.
- When installing, never incline oil seal.
- Apply multi-purpose grease onto oil seal lips, and gear oil onto the circumference of oil seal.

16. Install electric controlled coupling assembly. Refer to [DLN-120, "Disassembly and Assembly"](#).

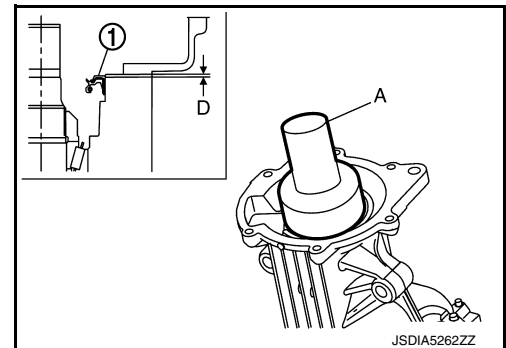
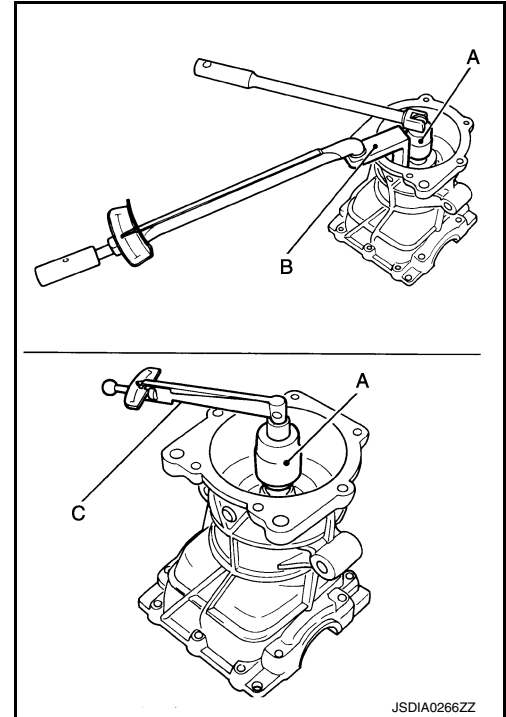
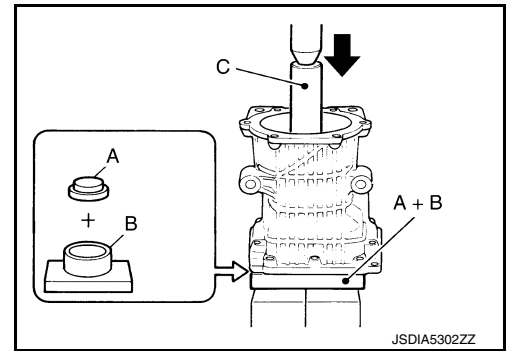

DRIVE PINION

< UNIT DISASSEMBLY AND ASSEMBLY >

[REAR FINAL DRIVE: R145]

Inspection

INFOID:000000012892978

A

INSPECTION AFTER DISASSEMBLY

Drive Gear and Drive Pinion

- Clean up the disassembled parts.
- If the gear teeth never mesh or line-up correctly, determine the cause and adjust or replace as necessary.
- If the gears are worn, cracked, damaged, pitted or chipped (by friction) noticeably, replace with new drive gear and drive pinion as a set.

B

C

Bearing

- Clean up the disassembled parts.
- If any chipped (by friction), pitted, worn, rusted or scratched marks, or unusual noise from the bearing is observed, replace as a bearing assembly (as a new set).

DLN

Oil Seal

- Whenever disassembled, replace.
- If wear, deterioration of adherence (sealing force lips), or damage is detected on the lips, replace them.

E

F

G

H

I

J

K

L

M

N

O

P

SERVICE DATA AND SPECIFICATIONS (SDS)

< SERVICE DATA AND SPECIFICATIONS (SDS)

[REAR FINAL DRIVE: R145]

SERVICE DATA AND SPECIFICATIONS (SDS)

SERVICE DATA AND SPECIFICATIONS (SDS)

General Specifications

INFOID:0000000012892979

Applied model	Axle	AWD
	Engine	VQ35DE
	Transaxle	CVT
Final drive model		R145
Gear ratio		2.466
Number of teeth (Drive gear/Drive pinion)		37/15
Number of pinion gears		2
Drive pinion adjustment spacer type		Collapsible
Oil capacity		Refer to MA-12. "Fluids and Lubricants" .

Preload Torque

INFOID:0000000012892980

Unit: N·m (kg-m, in-lb)

Item	Standard
Pinion bearing (P1)	0.69 – 1.18 (0.07 – 0.12, 7 – 10)
Side bearing (P2)	0.66 – 1.00 (0.07 – 0.10, 6 – 8)
Side bearing to pinion bearing (Total preload) (Total preload = P1 + P2)	1.35 – 2.18 (0.14 – 0.22, 12 – 19)

Drive Gear Runout

INFOID:0000000012892981

Unit: mm (in)

Item	Standard
Drive gear back face runout	0.05 (0.0020) or less

Backlash

INFOID:0000000012892982

Unit: mm (in)

Item	Standard
Drive gear to drive pinion gear	0.10 – 0.15 (0.0039 – 0.0059)

Differential Side Gear Clearance

INFOID:0000000012892983

Unit: mm (in)

Item	Standard
Side gear backlash (Clearance between side gear and differential case)	0.10 (0.004) or less (Each gear should rotate smoothly without excessive resistance during differential motion.)