

SECTION **EX**  
EXHAUST SYSTEM

A  
EX  
C  
D  
E  
F  
G  
H  
I  
J  
K  
L  
M  
N  
O  
P

CONTENTS

<b>PRECAUTION</b> .....	2	<b>PERIODIC MAINTENANCE</b> .....	4
<b>PRECAUTIONS</b> .....	2	<b>EXHAUST SYSTEM</b> .....	4
Precaution for Supplemental Restraint System (SRS) "AIR BAG" and "SEAT BELT PRE-TEN- SIONER" .....	2	Checking Exhaust System .....	4
<b>PREPARATION</b> .....	3	<b>REMOVAL AND INSTALLATION</b> .....	5
<b>PREPARATION</b> .....	3	<b>EXHAUST SYSTEM</b> .....	5
Commercial Service Tool .....	3	Exploded View .....	5
		Removal and Installation .....	5

# PRECAUTIONS

< PRECAUTION >

## PRECAUTION

### PRECAUTIONS

#### Precaution for Supplemental Restraint System (SRS) "AIR BAG" and "SEAT BELT PRE-TENSIONER"

INFOID:000000012891605

The Supplemental Restraint System such as "AIR BAG" and "SEAT BELT PRE-TENSIONER", used along with a front seat belt, helps to reduce the risk or severity of injury to the driver and front passenger for certain types of collision. Information necessary to service the system safely is included in the SR and SB section of this Service Manual.

**WARNING:**

- To avoid rendering the SRS inoperative, which could increase the risk of personal injury or death in the event of a collision which would result in air bag inflation, it is recommended that all maintenance and repair be performed by an authorized NISSAN/INFINITI dealer.
- Improper repair, including incorrect removal and installation of the SRS, can lead to personal injury caused by unintentional activation of the system. For removal of Spiral Cable and Air Bag Module, see the SR section.
- Do not use electrical test equipment on any circuit related to the SRS unless instructed to in this Service Manual. SRS wiring harnesses can be identified by yellow and/or orange harnesses or harness connectors.

#### PRECAUTIONS WHEN USING POWER TOOLS (AIR OR ELECTRIC) AND HAMMERS

**WARNING:**

- When working near the Air Bag Diagnosis Sensor Unit or other Air Bag System sensors with the Ignition ON or engine running, DO NOT use air or electric power tools or strike near the sensor(s) with a hammer. Heavy vibration could activate the sensor(s) and deploy the air bag(s), possibly causing serious injury.
- When using air or electric power tools or hammers, always switch the Ignition OFF, disconnect the battery or batteries, and wait at least three minutes before performing any service.

# PREPARATION

< PREPARATION >

## PREPARATION

### PREPARATION

#### Commercial Service Tool

INFOID:0000000012891606

A

EX

Tool name	Description
<p data-bbox="162 411 272 441">Power tool</p>  <p data-bbox="828 630 893 651">PIIB1407E</p>	<p data-bbox="1006 411 1347 441">Loosening nuts, screws and bolts</p>

C

D

E

F

G

H

I

J

K

L

M

N

O

P

# EXHAUST SYSTEM

< PERIODIC MAINTENANCE >

## PERIODIC MAINTENANCE

### EXHAUST SYSTEM

#### Checking Exhaust System

INFOID:000000012891607

Check exhaust pipes, muffler and mounts for improper attachment, leaks, cracks, damage or deterioration. Repair or replace as necessary.

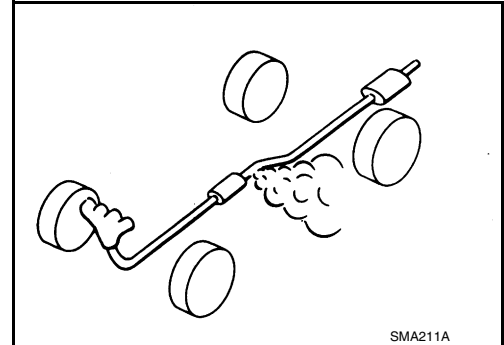

# EXHAUST SYSTEM

< REMOVAL AND INSTALLATION >

## REMOVAL AND INSTALLATION

### EXHAUST SYSTEM

Exploded View

INFOID:000000012891608

A

EX

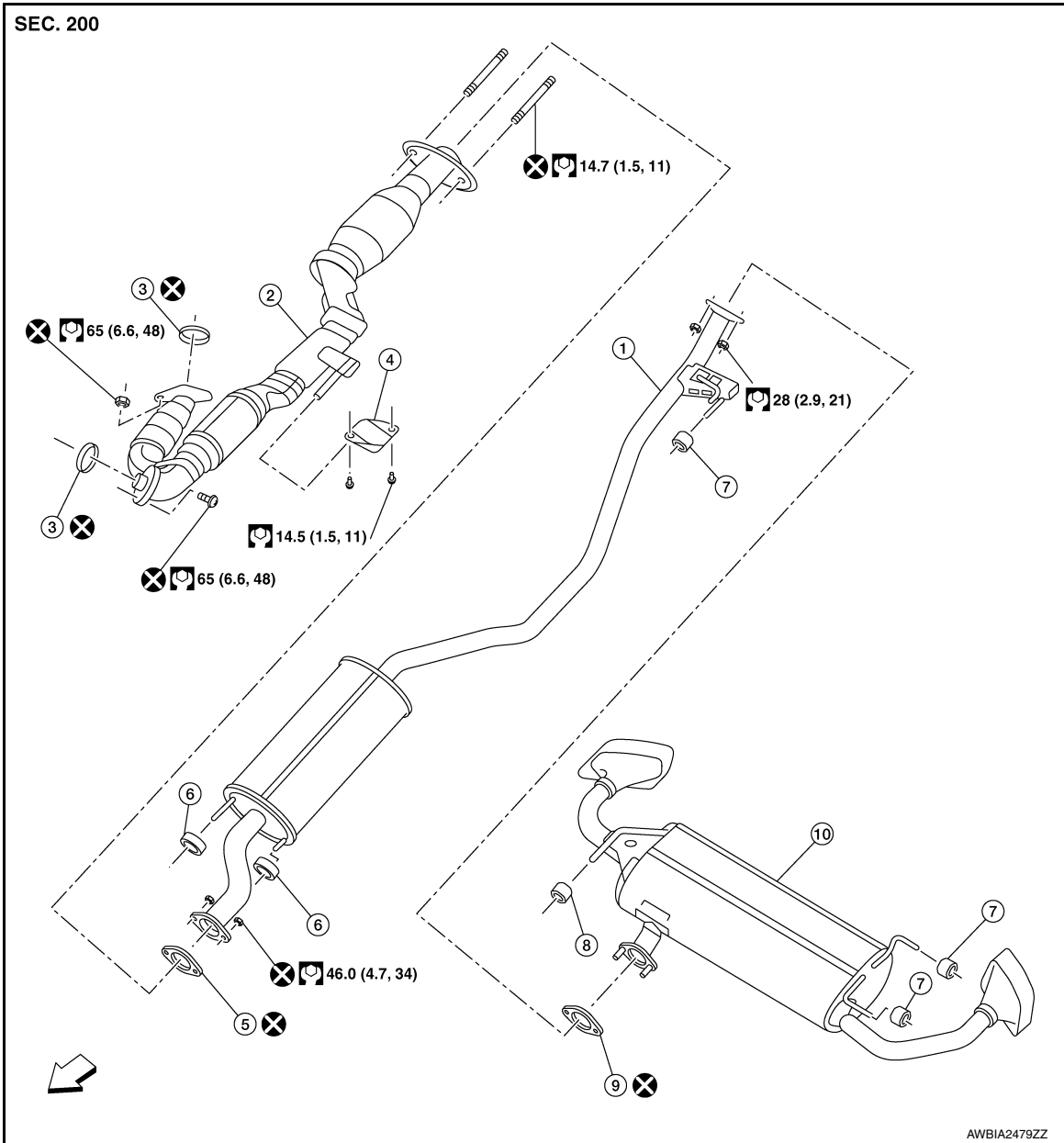

C

D

E

F

G

H

I

J

K

L

M

N

- |                               |                       |                    |
|-------------------------------|-----------------------|--------------------|
| 1. Center exhaust tube        | 2. Front exhaust tube | 3. Ring gasket     |
| 4. Front exhaust tube bracket | 5. Gasket             | 6. Mounting rubber |
| 7. Mounting rubber            | 8. Mounting rubber    | 9. Gasket          |
| 10. Muffler                   | ↩ Front               |                    |

O

P

### Removal and Installation

INFOID:000000012891609

#### WARNING:

- Perform the procedure with the exhaust system fully cooled down because the system will be hot just after the engine is turned off.
- Be careful not to cut your hand on the insulator edges.

# EXHAUST SYSTEM

## < REMOVAL AND INSTALLATION >

---

### **CAUTION:**

- Use Genuine NISSAN exhaust system parts or equivalent, which are specifically designed for heat resistance, corrosion resistance, and shape.

### REMOVAL

Remove exhaust system components using a power tool.

### INSTALLATION

Installation is in the reverse order of removal.

### **CAUTION:**

- Do not reuse exhaust gaskets.
- Do not reuse ring gaskets.
- Do not reuse nuts.
- Do not allow anti-corrosive wax to contact exhaust system components.
- Ensure flexible exhaust tube is free from deformation.
- If any mounting insulator is badly deformed, repair or replace it. If deposits such as mud pile up on the mounting insulator, clean and inspect it.
- When installing the insulator, avoid large gaps or interference between the insulator and each exhaust pipe.
- Remove deposits from the sealing surface of each connection. Connect them securely to avoid exhaust gas leaks.
- Temporarily tighten the exhaust manifold side nuts and the vehicle side bolts. Check each part for any interference, and then tighten the nuts and bolts to specification.
- When installing each mounting rubber, avoid twisting or excessive extension in up/down and right/left directions.
- Tighten the bolts without causing interference with the flange.