

SECTION **HA**

**HEATER & AIR CONDITIONING SYSTEM**

**CONTENTS**

<b>PRECAUTION</b> .....	<b>3</b>	<b>REFRIGERANT</b> .....	<b>20</b>
<b>PRECAUTIONS</b> .....	<b>3</b>	Description .....	20
Precaution for Supplemental Restraint System (SRS) "AIR BAG" and "SEAT BELT PRE-TENSIONER" .....	3	Leak Test .....	20
Precaution for Work .....	3	Recycle Refrigerant .....	22
Precaution for Procedure without Cowl Top Cover.....	4	Charge Refrigerant .....	22
Precautions For Refrigerant System Service .....	4	<b>OIL</b> .....	<b>24</b>
Service Equipment .....	6	Description .....	24
<b>PREPARATION</b> .....	<b>9</b>	Inspection .....	24
<b>PREPARATION</b> .....	<b>9</b>	Perform Oil Return Operation .....	24
Special Service Tool .....	9	Oil Adjusting Procedure for Components Replacement Except Compressor .....	24
Commercial Service Tool .....	10	Oil Adjusting Procedure for Compressor Replacement .....	25
Sealant and/or Oil .....	11	<b>PERFORMANCE TEST</b> .....	<b>27</b>
<b>SYSTEM DESCRIPTION</b> .....	<b>12</b>	Inspection .....	27
<b>COMPONENT PARTS</b> .....	<b>12</b>	<b>REMOVAL AND INSTALLATION</b> .....	<b>29</b>
Component Parts Location .....	12	<b>COMPRESSOR</b> .....	<b>29</b>
Component Description .....	12	Exploded View .....	29
<b>SYSTEM</b> .....	<b>13</b>	<b>COMPRESSOR</b> .....	<b>29</b>
System Diagram .....	13	COMPRESSOR : Removal and Installation .....	29
System Description .....	13	<b>MAGNET CLUTCH</b> .....	<b>30</b>
<b>BASIC INSPECTION</b> .....	<b>15</b>	MAGNET CLUTCH : Removal and Installation of Compressor Clutch .....	30
<b>DIAGNOSIS AND REPAIR WORKFLOW</b> .....	<b>15</b>	<b>COOLER PIPE AND HOSE</b> .....	<b>33</b>
Workflow .....	15	Exploded View .....	33
<b>SYMPTOM DIAGNOSIS</b> .....	<b>17</b>	<b>HIGH-PRESSURE AND LOW-PRESSURE PIPE</b> .....	<b>33</b>
<b>REFRIGERATION SYSTEM SYMPTOMS</b> .....	<b>17</b>	HIGH-PRESSURE AND LOW-PRESSURE PIPE : Removal and Installation .....	33
Trouble Diagnosis For Unusual Pressure .....	17	<b>LOW-PRESSURE FLEXIBLE HOSE</b> .....	<b>34</b>
Symptom Table .....	17	LOW-PRESSURE FLEXIBLE HOSE : Removal and Installation .....	34
<b>NOISE</b> .....	<b>19</b>	<b>HIGH-PRESSURE PIPE</b> .....	<b>34</b>
Symptom Table .....	19		
<b>PERIODIC MAINTENANCE</b> .....	<b>20</b>		

A  
B  
C  
D  
E  
F  
G  
H  
HA  
J  
K  
L  
M  
N  
O  
P

HIGH-PRESSURE PIPE : Removal and Installation .....	34	Removal and Installation .....	41
<b>HIGH-PRESSURE FLEXIBLE HOSE .....</b>	<b>34</b>	<b>HEATER CORE .....</b>	<b>43</b>
HIGH-PRESSURE FLEXIBLE HOSE : Removal and Installation .....	34	Exploded View .....	43
<b>CONDENSER .....</b>	<b>36</b>	Removal and Installation .....	43
Exploded View .....	36	<b>EVAPORATOR .....</b>	<b>44</b>
Removal and Installation .....	36	Removal and Installation .....	44
<b>CONDENSER PIPE ASSEMBLY .....</b>	<b>38</b>	<b>EXPANSION VALVE .....</b>	<b>45</b>
Removal and Installation .....	38	Removal and Installation .....	45
<b>LIQUID TANK .....</b>	<b>39</b>	<b>SERVICE DATA AND SPECIFICATIONS (SDS) .....</b>	<b>46</b>
Removal and Installation .....	39	<b>SERVICE DATA AND SPECIFICATIONS (SDS) .....</b>	<b>46</b>
<b>REFRIGERANT PRESSURE SENSOR .....</b>	<b>40</b>	Compressor .....	46
Removal and Installation .....	40	Oil .....	46
<b>HEATING AND COOLING UNIT ASSEMBLY... ..</b>	<b>41</b>	Refrigerant .....	46
Exploded View .....	41		

# PRECAUTIONS

< PRECAUTION >

## PRECAUTION

### PRECAUTIONS

#### Precaution for Supplemental Restraint System (SRS) "AIR BAG" and "SEAT BELT PRE-TENSIONER"

INFOID:000000013381927

The Supplemental Restraint System such as "AIR BAG" and "SEAT BELT PRE-TENSIONER", used along with a front seat belt, helps to reduce the risk or severity of injury to the driver and front passenger for certain types of collision. Information necessary to service the system safely is included in the SR and SB section of this Service Manual.

#### **WARNING:**

- To avoid rendering the SRS inoperative, which could increase the risk of personal injury or death in the event of a collision which would result in air bag inflation, it is recommended that all maintenance and repair be performed by an authorized NISSAN/INFINITI dealer.
- Improper repair, including incorrect removal and installation of the SRS, can lead to personal injury caused by unintentional activation of the system. For removal of Spiral Cable and Air Bag Module, see the SR section.
- Do not use electrical test equipment on any circuit related to the SRS unless instructed to in this Service Manual. SRS wiring harnesses can be identified by yellow and/or orange harnesses or harness connectors.

#### PRECAUTIONS WHEN USING POWER TOOLS (AIR OR ELECTRIC) AND HAMMERS

#### **WARNING:**

- When working near the Air Bag Diagnosis Sensor Unit or other Air Bag System sensors with the Ignition ON or engine running, DO NOT use air or electric power tools or strike near the sensor(s) with a hammer. Heavy vibration could activate the sensor(s) and deploy the air bag(s), possibly causing serious injury.
- When using air or electric power tools or hammers, always switch the Ignition OFF, disconnect the battery or batteries, and wait at least three minutes before performing any service.

#### Precaution for Work

INFOID:000000012876675

- When removing or disassembling each component, be careful not to damage or deform it. If a component may be subject to interference, be sure to protect it with a shop cloth.
- When removing (disengaging) components with a screwdriver or similar tool, be sure to wrap the component with a shop cloth or vinyl tape to protect it.
- Protect the removed parts with a shop cloth and prevent them from being dropped.
- Replace a deformed or damaged clip.
- If a part is specified as a non-reusable part, always replace it with a new one.
- Be sure to tighten bolts and nuts securely to the specified torque.
- After installation is complete, be sure to check that each part works properly.
- Follow the steps below to clean components:
  - Water soluble dirt:
    - Dip a soft cloth into lukewarm water, wring the water out of the cloth and wipe the dirty area.
    - Then rub with a soft, dry cloth.
  - Oily dirt:
    - Dip a soft cloth into lukewarm water with mild detergent (concentration: within 2 to 3%) and wipe the dirty area.
    - Then dip a cloth into fresh water, wring the water out of the cloth and wipe the detergent off.
    - Then rub with a soft, dry cloth.
  - Do not use organic solvent such as thinner, benzene, alcohol or gasoline.
  - For genuine leather seats, use a genuine leather seat cleaner.

# PRECAUTIONS

## < PRECAUTION >

### Precaution for Procedure without Cowl Top Cover

INFOID:000000012876676

When performing the procedure after removing cowl top cover, cover the lower end of windshield with urethane, etc., to prevent damage to windshield.

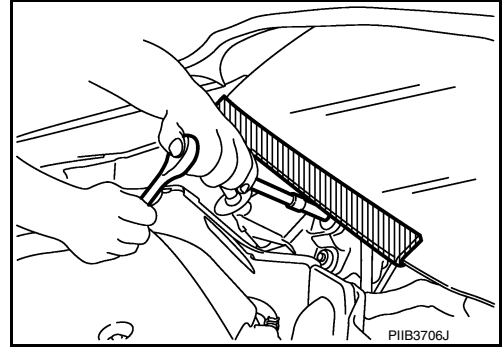

### Precautions For Refrigerant System Service

INFOID:000000012876677

#### GENERAL REFRIGERANT PRECAUTION

##### **WARNING:**

- Do not breathe A/C refrigerant and oil vapor or mist. Exposure may irritate eyes, nose and throat. Remove HFC-134a (R-134a) from the A/C system using certified service equipment meeting requirements of SAE J-2210 [HFC-134a (R-134a) recycling equipment] or J-2209 [HFC-134a (R-134a) recovery equipment]. Ventilate work area before resuming service if accidental system discharge occurs. Additional health and safety information may be obtained from refrigerant and oil manufacturers.
- Do not release refrigerant into the air. Use approved recovery/recycling/recharging equipment to capture the refrigerant each time an air conditioning system is discharged.
- Always wear eye and hand protection (goggles and gloves) when working with any refrigerant or air conditioning system.
- Do not store or heat refrigerant containers above 52°C (126°F).
- Do not heat a refrigerant container with an open flame. Place the bottom of the container in a warm pail of water if container warming is required.
- Do not intentionally drop, puncture or incinerate refrigerant containers.
- Keep refrigerant away from open flames; poisonous gas is produced if refrigerant burns.
- Refrigerant displaces oxygen; therefore, be certain to work in well-ventilated areas to prevent suffocation.
- Do not pressure test or leak test HFC-134a (R-134a) service equipment and/or vehicle air conditioning systems with compressed air during repair. Some mixtures of air and HFC-134a (R-134a) have been shown to be combustible at elevated pressures. These mixtures, if ignited, may cause injury or property damage. Additional health and safety information may be obtained from refrigerant manufacturers.

#### WORKING WITH HFC-134a (R-134a)

##### **CAUTION:**

- CFC-12 (R-12) refrigerant and HFC-134a (R-134a) refrigerant are not compatible. Compressor malfunction is likely to occur if the refrigerants are mixed; refer to "CONTAMINATED REFRIGERANT" below. To determine the purity of HFC-134a (R-134a) in the vehicle and recovery tank, use refrigerant recovery/recycling/recharging equipment and refrigerant identifier.
- Use only specified oil for the HFC-134a (R-134a) A/C system and HFC-134a (R-134a) components. Compressor malfunction is likely to occur if oil other than that specified is used.
- The specified HFC-134a (R-134a) oil rapidly absorbs moisture from the atmosphere. The following handling precautions must be observed:
  - Cap (seal) the component immediately to minimize the entry of moisture from the atmosphere when removing refrigerant components from a vehicle.
  - Do not remove the caps (unseal) until just before connecting the components when installing refrigerant components to a vehicle. Connect all refrigerant loop components as quickly as possible to minimize the entry of moisture into the system.
  - Use only the specified oil from a sealed container. Reseal containers of oil immediately. Oil becomes moisture saturated and should not be used without proper sealing.
  - Do not allow oil to come in contact with styrene foam parts. Damage may result.

#### O-RING AND REFRIGERANT CONNECTION

A new type of refrigerant connection has been introduced to all refrigerant lines except the following locations:

# PRECAUTIONS

## < PRECAUTION >

- Expansion valve to evaporator
- Refrigerant pressure sensor to liquid tank

### WARNING:

Check that all refrigerant is discharged into the recycling equipment and the pressure in the system is less than atmospheric pressure. Then gradually loosen the discharge side hose fitting and remove it.

### CAUTION:

Observe the following when replacing or cleaning refrigerant components.

- Store it in the same way as it is when mounted on the vehicle when the compressor is removed. Failure to do so will cause oil to enter the low-pressure chamber.
- Always use a torque wrench and a back-up wrench when connecting tubes.
- Immediately plug all openings to prevent entry of dust and moisture after disconnecting tubes.
- Connect the pipes at the final stage of the operation when installing an air conditioner in the vehicle. Do not remove the seal caps of pipes and other components until just before required for connection.
- Allow components stored in cool areas to warm to working area temperature before removing seal caps. This prevents condensation from forming inside A/C components.
- Remove moisture thoroughly from the refrigeration system before charging the refrigerant.
- Always replace used O-rings.
- Apply oil to the O-rings shown in illustrations when connecting the tubes. Be careful not to apply oil to threaded portion.
- The O-ring must be closely attached to the groove portion of tube.
- Be careful not to damage the O-ring and tube when replacing the O-ring.
- Connect the tube until a click can be heard. Then tighten the nut or bolt by hand. Check that the O-ring is installed to tube correctly.
- Perform leak test and make sure that there are no leaks from the connections after connecting the line. Disconnect that line and replace the O-ring when the refrigerant leaking point is found. Then tighten the connections of the seal seat to the specified torque.

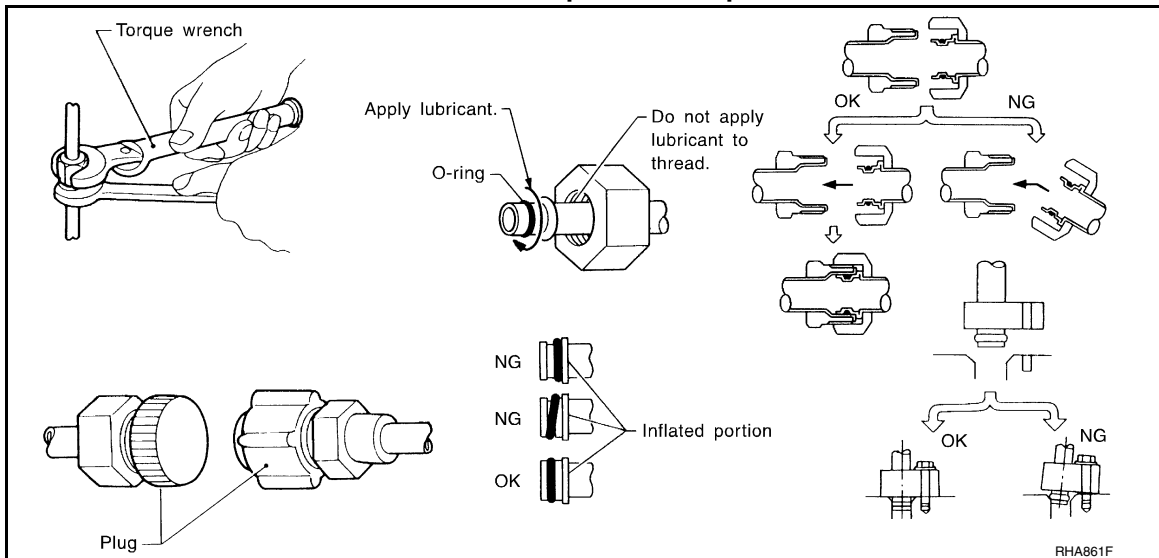

## CONTAMINATED REFRIGERANT

Take appropriate steps shown below if a refrigerant other than pure HFC-134a (R-134a) is identified in a vehicle:

- Explain to the customer that environmental regulations prohibit the release of contaminated refrigerant into the atmosphere.
- Explain that recovery of the contaminated refrigerant could damage service equipment and refrigerant supply.
- Suggest the customer return the vehicle to the location of previous service where the contamination may have occurred.
- In case of repairing, recover the refrigerant using only **dedicated equipment and containers**. Do not **recover contaminated refrigerant into the existing service equipment**. Contact a local refrigerant product retailer for available service if the facility does not have dedicated recovery equipment. This refrigerant must be disposed of in accordance with all federal and local regulations. In addition, replacement of all refrigerant system components on the vehicle is recommended.

# PRECAUTIONS

## < PRECAUTION >

- The air conditioner warranty is void if the vehicle is within the warranty period. Please contact NISSAN Customer Affairs for further assistance.

## COMPRESSOR

### CAUTION:

- Plug all openings to prevent moisture and foreign matter from entering.
- Store it in the same way as it is when mounted on the car when the compressor is removed.
- Follow "Maintenance of Oil Quantity in Compressor" exactly when replacing or repairing compressor. Refer to [HA-24, "Description"](#).
- Keep friction surfaces between clutch and pulley clean. Wipe it off by using a clean waste cloth moistened with solvent if the surface is contaminated with oil.
- Turn the compressor shaft by hand more than five turns in both directions after compressor service operation. This distributes oil equally inside the compressor. Let the engine idle and operate the compressor for one hour after the compressor is installed.
- Apply voltage to the new one and check for normal operation after replacing the compressor magnet clutch.

## LEAK DETECTION DYE

### CAUTION:

- The A/C system contains a fluorescent leak detection dye used for locating refrigerant leaks. An ultraviolet (UV) lamp is required to illuminate the dye when inspecting for leaks.
- Always wear fluorescence enhancing UV safety goggles to protect eyes and enhance the visibility of the fluorescent dye.
- The fluorescent dye leak detector is not a replacement for an electronic leak detector (SST: J-41995). The fluorescent dye leak detector should be used in conjunction with an electronic leak detector (SST: J-41995) to pinpoint refrigerant leaks.
- Read and follow all manufacturer's operating instructions and precautions prior to performing the work for the purpose of safety and customer's satisfaction.
- A compressor shaft seal should not necessarily be repaired because of dye seepage. The compressor shaft seal should only be repaired after confirming the leak with an electronic leak detector (SST: J-41995).
- Always remove any remaining dye from the leak area after repairs are completed to avoid a misdiagnosis during a future service.
- Do not allow dye to come into contact with painted body panels or interior components. Clean immediately with the approved dye cleaner if dye is spilled. Fluorescent dye left on a surface for an extended period of time cannot be removed.
- Do not spray the fluorescent dye cleaning agent on hot surfaces (engine exhaust manifold, etc.).
- Do not use more than one refrigerant dye bottle [1/4 ounce (7.4 cc)] per A/C system.
- Leak detection dyes for HFC-134a (R-134a) and CFC-12 (R-12) A/C systems are different. Do not use HFC-134a (R-134a) leak detection dye in a CFC-12 (R-12) A/C system or CFC-12 (R-12) leak detection dye in a HFC-134a (R-134a) A/C system. A/C system damage may result.
- The fluorescent properties of the dye remain for three or more years unless a compressor malfunction occurs.

### NOTE:

#### Identification

- Vehicles with factory installed fluorescent dye have a green label.
- Vehicles without factory installed fluorescent dye have a blue label.

## Service Equipment

INFOID:000000012876678

## RECOVERY/RECYCLING RECHARGING EQUIPMENT

Be certain to follow the manufacturer's instructions for machine operation and machine maintenance. Do not introduce any refrigerant other than that specified into the machine.

## ELECTRONIC LEAK DETECTOR

Be certain to follow the manufacturer's instructions for detector operation and maintenance.

## VACUUM PUMP

# PRECAUTIONS

## < PRECAUTION >

The oil contained inside the vacuum pump is not compatible with the specified oil for HFC-134a (R-134a) A/C systems. The vent side of the vacuum pump is exposed to atmospheric pressure, so the vacuum pump oil may migrate out of the pump into the service hose. This is possible when the pump is switched OFF after evacuation (vacuuming) and hose is connected to it.

To prevent this migration, use a manual valve placed near the hose-to-pump connection as per the following:

- Vacuum pumps usually have a manual isolator valve as part of the pump. Close this valve to isolate the service hose from the pump.
- Use a hose equipped with a manual shut-off valve near the pump end for pumps without an isolator. Close the valve to isolate the hose from the pump.
- Disconnect the hose from the pump if the hose has an automatic shut-off valve. As long as the hose is connected, the valve is open and oil may migrate.

Some one-way valves open when vacuum is applied and close under no vacuum condition. Such valves may restrict the pump's ability to pull a deep vacuum and are not recommended.

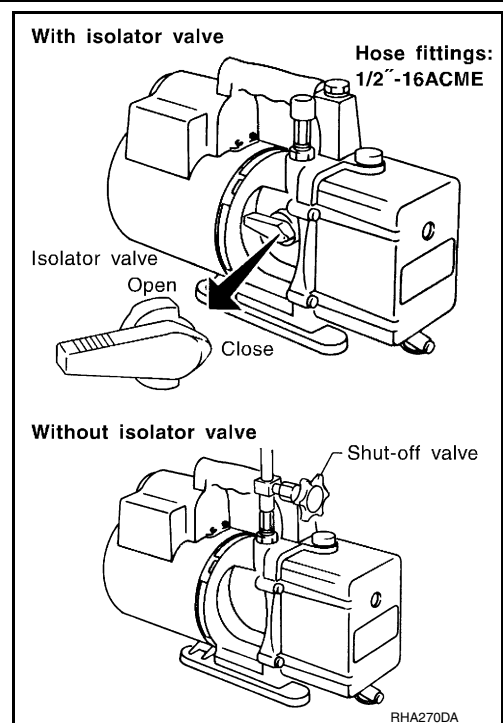

## MANIFOLD GAUGE SET

Be certain that the gauge face indicates HFC-134a or R-134a. Be sure the gauge set has 1/2"-16 ACME threaded connections for service hoses. Confirm the set has been used only with refrigerant HFC-134a (R-134a) and specified oils.

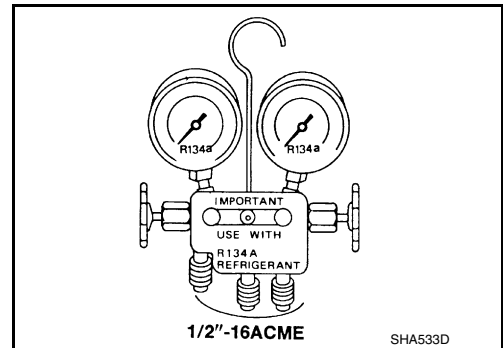

## SERVICE HOSES

Be certain that the service hoses display the markings described (colored hose with black stripe). All hoses must include positive shut-off devices (either manual or automatic) near the end of the hoses opposite to the manifold gauge.

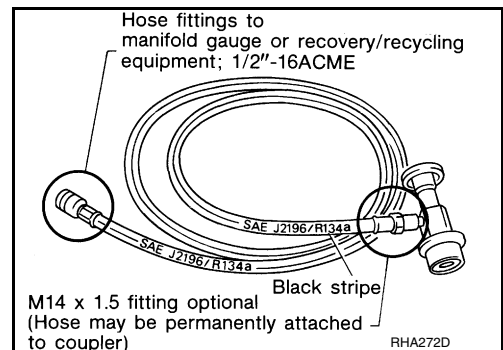

## SERVICE COUPLERS

# PRECAUTIONS

## < PRECAUTION >

Do not attempt to connect HFC-134a (R-134a) service couplers to the CFC-12 (R-12) A/C system. The HFC-134a (R-134a) couplers do not properly connect to the CFC-12 (R-12) system. However, if an improper connection is attempted, discharging and contamination may occur.

Shut-off valve rotation	A/C service valve
Clockwise	Open
Counterclockwise	Close

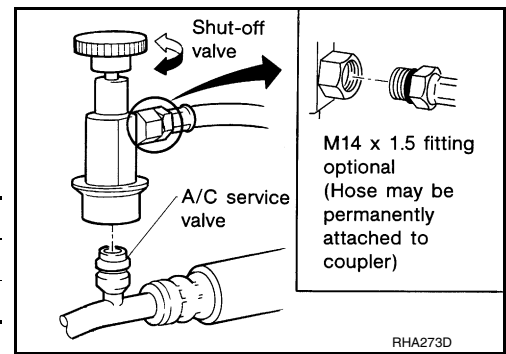

## REFRIGERANT WEIGHT SCALE

Verify that no refrigerant other than HFC-134a (R-134a) and specified oils have been used with the scale. The hose fitting must be 1/2"-16 ACME if the scale controls refrigerant flow electronically.

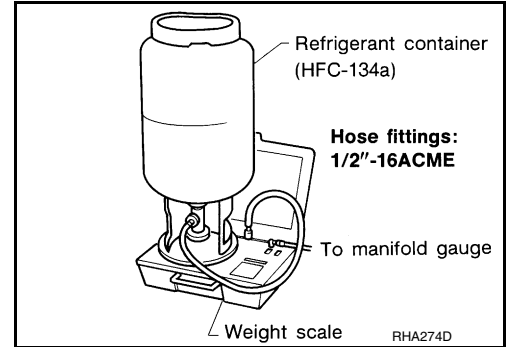

## CHARGING CYLINDER

Using a charging cylinder is not recommended. Refrigerant may be vented into air from cylinder's top valve when filling the cylinder with refrigerant. Also, the accuracy of the cylinder is generally less than that of an electronic scale or of quality recycle/recharging equipment.



# PREPARATION

< PREPARATION >



## PREPARATION

### PREPARATION

#### Special Service Tool

INFOID:0000000012876679

The actual shape of the tools may differ from those illustrated here.

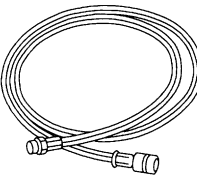
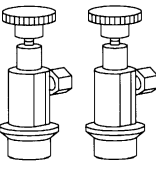
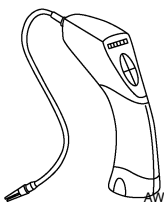
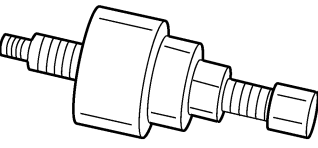
(TechMate No.) Tool name	Description
(J-41425-NIS) Aluminum Tubing Repair Kit <div style="text-align: center;">  <p>ALIIA0390ZZ</p> </div>	Repairing leaks in A/C tubes
(J-48710) ACR2009 RRR Unit <div style="text-align: center;">  <p>WJIA0293E</p> </div>	Refrigerant recovery, recycling and re-charging
Service Hoses: (J-39500-72B) Low-side Hose (J-39500-72R) High-side Hose (J-39500-72Y) Utility hose <div style="text-align: center;">  <p>S-NT201</p> </div>	Hose color: Low side hose: Blue with black stripe High side hose: Red with black stripe Utility hose: Yellow with black stripe or green with black stripe Hose fitting to gauge: 1/2"-16 ACME
Service Couplers: (J-39500-20A) High-side Coupler (J-39500-24A) Low-side Coupler <div style="text-align: center;">  <p>S-NT202</p> </div>	Hose fitting to service hose: M14 x 1.5 fitting is optional or permanently attached
(TIFZX) Electronic Refrigerant Leak Detector <div style="text-align: center;">  <p>AWIIA1921ZZ</p> </div>	Detects refrigerant leaks
(J-38873-A) Drive plate installer <div style="text-align: center;">  <p>WJIA0367E</p> </div>	Installing pulley

A

B

C

D

E

F

G

H

HA

J

K

L

M

N

O

P

# PREPARATION

## < PREPARATION >

(TechMate No.) Tool name	Description
<p>(J-43926) Refrigerant Dye Leak Detection Kit</p> <p>Kit includes: (J-42220) UV lamp and UV safety goggles (J-41459) Refrigerant dye injector (J-41447) Fluorescent leak detection dye (box of 24, 1/4 ounce bottles) (J-43872) Refrigerant dye cleaner</p>	<p>Power supply: DC 12V (battery terminal)</p>
<p>(J-46534) Trim Tool Set</p>	<p>Removing trim components</p>

## Commercial Service Tool

INFOID:000000012876680

(TechMate No.) Tool name	Description
<p>(J-39599) Vacuum Pump</p>	<p>Evacuates air from A/C system</p>
<p>( — ) Refrigerant Identifier Equipment (R-134a)</p>	<p>For checking refrigerant purity and system contamination</p>
<p>( — ) Manifold Gauge Set (with hoses and couplers)</p>	<p>Identification:</p> <ul style="list-style-type: none"> <li>The gauge face indicates R-134a</li> <li>Fitting size-Thread size</li> <li>1/2"-16 ACME</li> </ul>

# PREPARATION

## < PREPARATION >

(TechMate No.) Tool name	Description	A
( — ) Refrigerant Weight Scale	For measuring of refrigerant Fitting size-Thread size • 1/2"-16 ACME	B C
( — ) Power Tool	Loosening nuts, screws and bolts	D E F

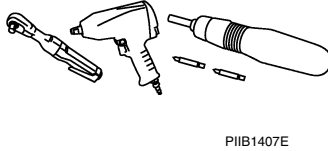
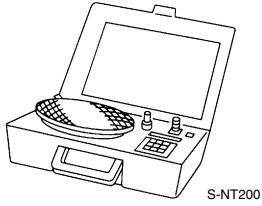

## Sealant and/or Oil

INFOID:000000012876681

Name	Description	G
HFC-134a (R-134a) Refrigerant	Container color: Light blue Container marking: HFC-134a (R-134a) Fitting size: Thread size • large container 1/2"-16 ACME	H HA
A/C System Oil: Polyalkylene Glycol (PAG)	A/C System Oil: ND-OIL8 (PAG) Application: HFC-134a (R-134a) compressors	J K L

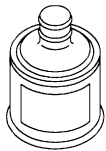
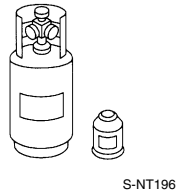

# COMPONENT PARTS

< SYSTEM DESCRIPTION >

## SYSTEM DESCRIPTION

### COMPONENT PARTS

#### Component Parts Location

INFOID:0000000012876682

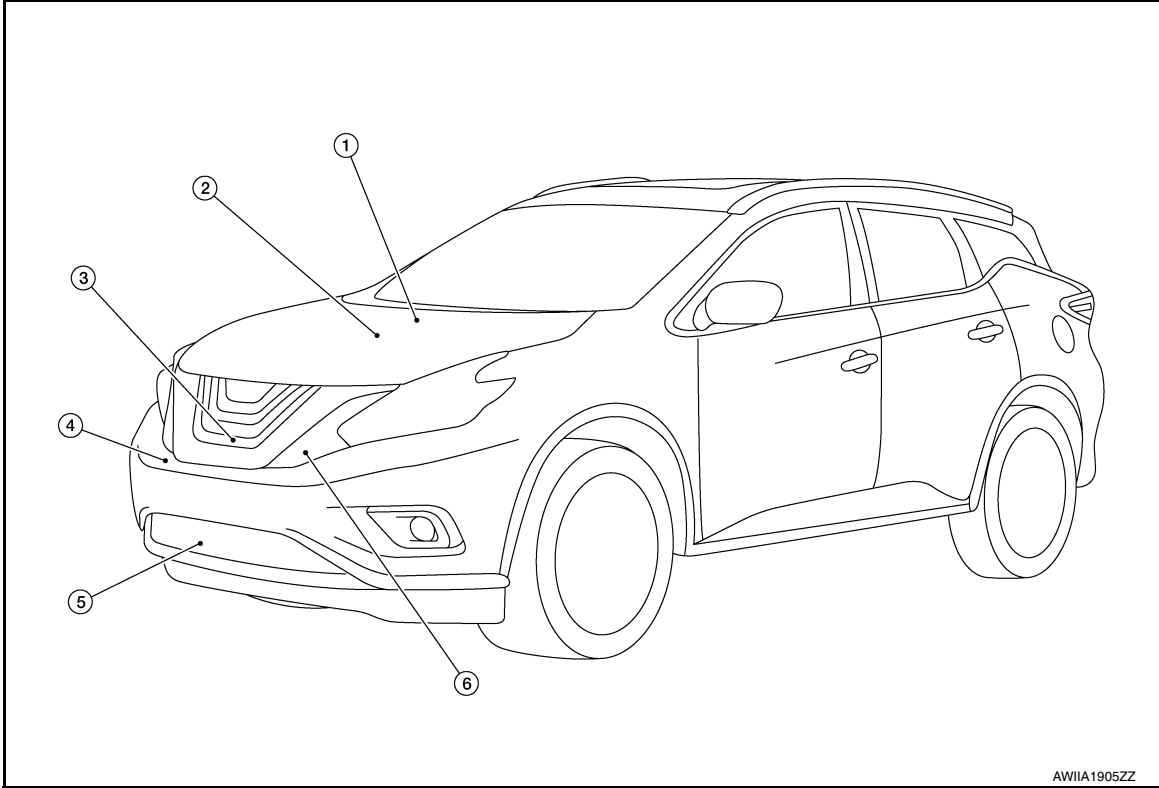

AWI1A1905ZZ

- |                                |                    |                |
|--------------------------------|--------------------|----------------|
| 1. Evaporator                  | 2. Expansion valve | 3. Condenser   |
| 4. Refrigerant pressure sensor | 5. Compressor      | 6. Liquid tank |

#### Component Description

INFOID:0000000012876683

Component	Description
Evaporator	Cools cabin air by absorbing heat. Transforms low-pressure liquid refrigerant to low-pressure gas refrigerant.
Condenser	Cools refrigerant discharged from compressor and transforms it from high-pressure gas refrigerant to high-pressure liquid refrigerant.
Compressor	Compresses low-pressure gas refrigerant into high-pressure gas refrigerant. Circulates refrigerant throughout the A/C system.
Refrigerant pressure sensor	Senses high side pressure in the liquid tank. Turns compressor off when system pressure becomes too high or too low.
Liquid tank	Eliminates foreign matter in refrigerant and temporarily stores liquid refrigerant.
Expansion valve	Transforms high-pressure liquid refrigerant to low-pressure mist refrigerant.

# SYSTEM

< SYSTEM DESCRIPTION >

## SYSTEM

### System Diagram

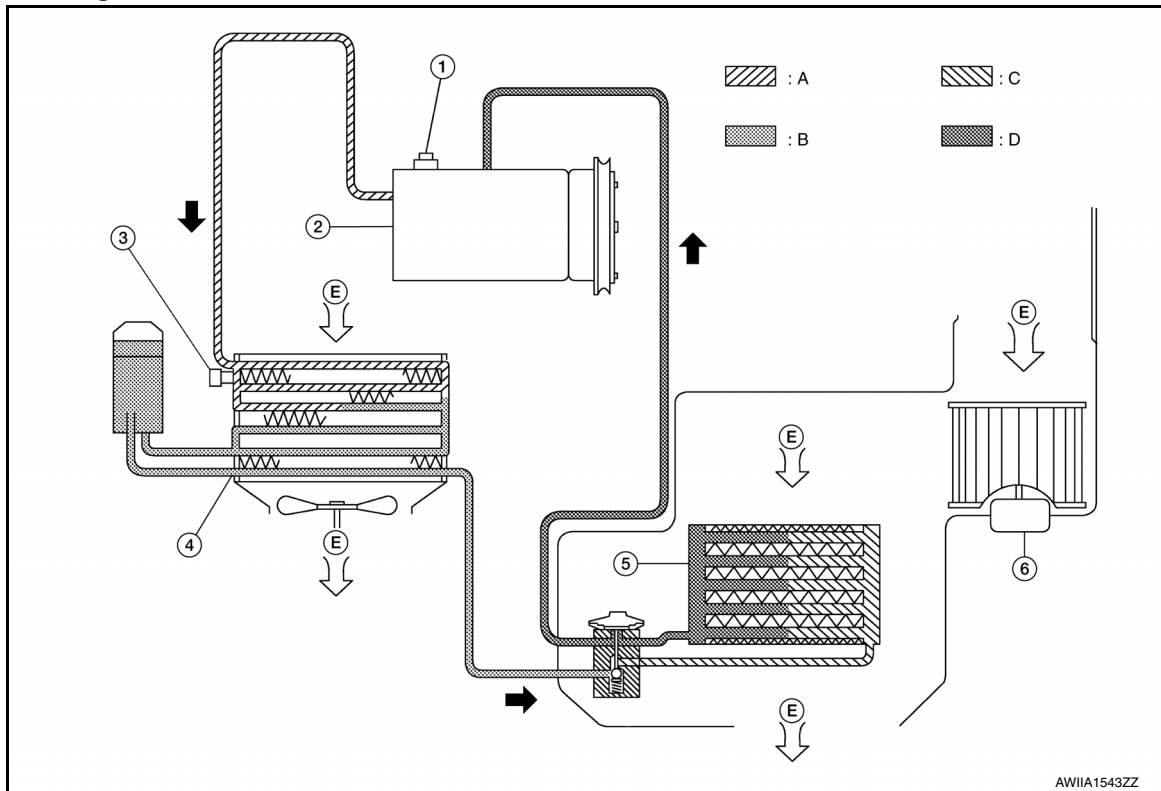

- |                                       |  |                                |
|---------------------------------------|--|--------------------------------|
| 1. Pressure relief valve              | 2. Compressor                              | 3. Refrigerant pressure sensor |
| 4. Condenser and liquid tank assembly | 5. Evaporator and expansion valve assembly | 6. Blower motor                |
| A. High-pressure gas                  | B. High-pressure liquid                    | C. Low-pressure liquid         |
| D. Low-pressure gas                   | E. Outside air                             |                                |

### System Description

INFOID:000000012876685

#### REFRIGERANT CYCLE

##### Refrigerant Flow

The refrigerant from the compressor flows through the condenser, liquid tank and evaporator and returns to the compressor. The refrigerant evaporation in the evaporator is controlled by an expansion valve.

##### Freeze Protection

To prevent evaporator from freezing up, the evaporator air temperature is monitored and the voltage signal to the A/C auto amp. makes the A/C relay go OFF and stop the compressor.

#### REFRIGERANT SYSTEM PROTECTION

##### Refrigerant Pressure Sensor

- The refrigerant system is protected against excessively high or low pressures by the refrigerant pressure sensor, located on the liquid tank. The refrigerant pressure sensor detects the pressure inside the refrigerant line and sends the voltage signal to the ECM if the system pressure rises above or falls below the specifications.
- ECM turns the A/C relay to OFF and stops the compressor when the high-pressure side is detected by refrigerant pressure sensor to have the following conditions:
  - Approximately 3,120 kPa (31.8 kg/cm<sup>2</sup>, 452 psi) or more (Engine speed is 1,500 rpm or more.)
  - Approximately 2,740 kPa (27.9 kg/cm<sup>2</sup>, 397 psi) or more (Engine speed is less than 1,500 rpm.)
  - Approximately 120 kPa (1.2 kg/cm<sup>2</sup>, 17 psi) or less

##### Pressure Relief Valve

## SYSTEM

### < SYSTEM DESCRIPTION >

---

The refrigerant system is also protected by a pressure relief valve, located in the rear head of the compressor. The release port on the pressure relief valve automatically opens and releases refrigerant into the atmosphere when the pressure of refrigerant in the system increases to an unusual level [more than 3,800 kPa (38.8 kg/cm<sup>2</sup>, 551 psi)].

# DIAGNOSIS AND REPAIR WORKFLOW

< BASIC INSPECTION >

## BASIC INSPECTION

### DIAGNOSIS AND REPAIR WORKFLOW

Workflow

INFOID:0000000012876686

#### OVERALL SEQUENCE

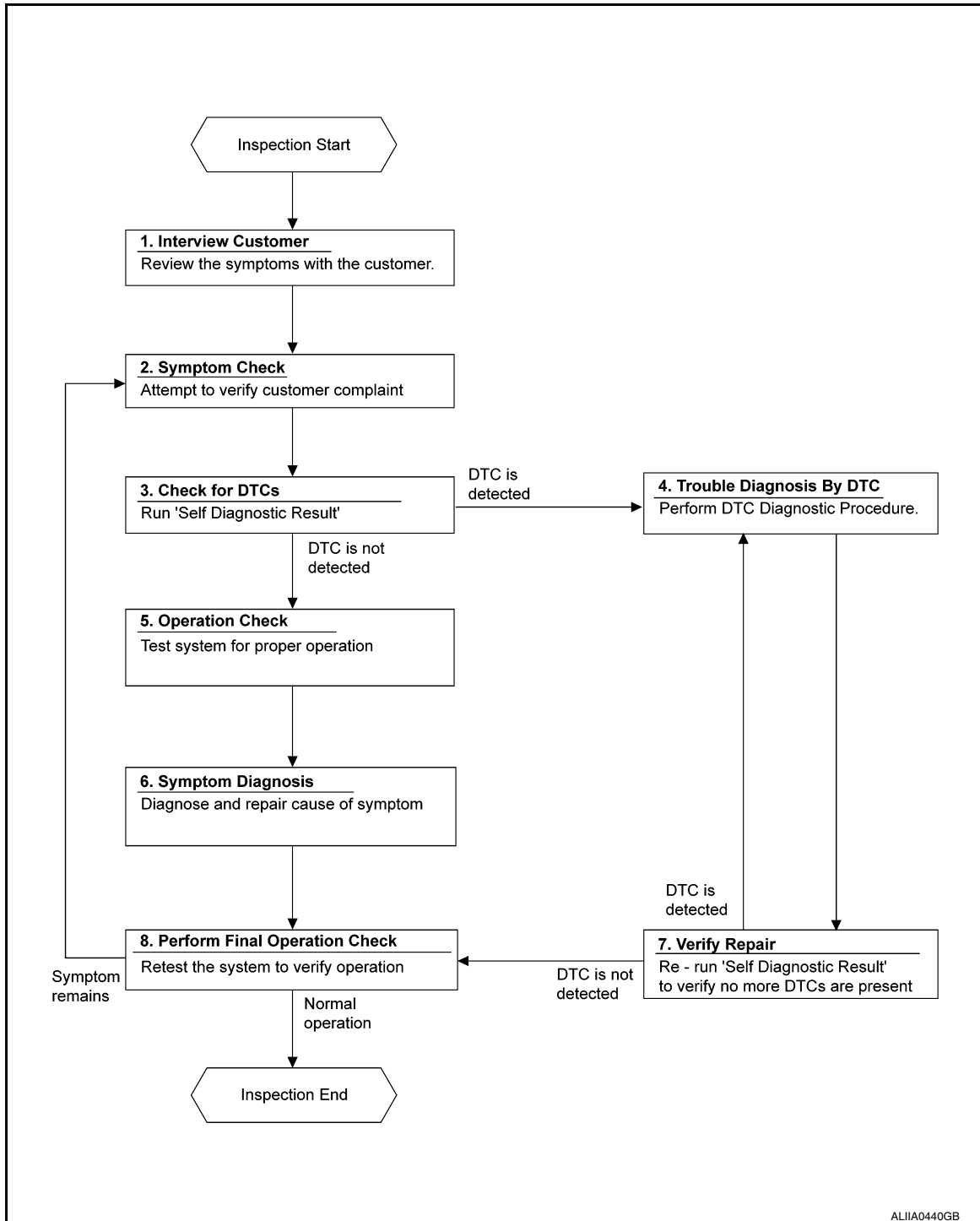

#### DETAILED FLOW

##### 1. INTERVIEW CUSTOMER

Interview the customer to obtain as much information as possible about the conditions and environment under which the malfunction occurred.

# DIAGNOSIS AND REPAIR WORKFLOW

< BASIC INSPECTION >

---

>> GO TO 2.

## 2. SYMPTOM CHECK

---

Verify symptoms.

>> GO TO 3.

## 3. CHECK FOR DTCS

---

 With CONSULT

1. Turn ignition switch ON.
2. Select "Self Diagnostic Result" mode of "HVAC".
3. Check DTC.

Is any DTC detected?

- YES >> GO TO 4.  
NO >> GO TO 5.

## 4. TROUBLE DIAGNOSIS BY DTC

---

Perform the diagnostic procedure for the detected DTC. Refer to [HAC-26. "DTC Index"](#).

>> GO TO 7.

## 5. OPERATION CHECK

---

Perform the operation check. Refer to [HAC-39. "Work Procedure"](#).

>> GO TO 6.

## 6. SYMPTOM DIAGNOSIS

---

Check the symptom diagnosis table. Refer to [HAC-84. "Diagnosis Chart By Symptom"](#).

>> GO TO 8.

## 7. VERIFY REPAIR.

---

 With CONSULT

1. Turn ignition switch ON.
2. Select "Self Diagnostic Result" mode of "HVAC".
3. Check DTC.

Is any DTC detected?

- YES >> GO TO 4.  
NO >> GO TO 8.

## 8. PERFORM FINAL OPERATION CHECK

---

Perform the operation check. Refer to [HAC-39. "Work Procedure"](#).

Does it operate normally?

- YES >> Inspection End.  
NO >> GO TO 2.



# REFRIGERATION SYSTEM SYMPTOMS

< SYMPTOM DIAGNOSIS >

## SYMPTOM DIAGNOSIS

### REFRIGERATION SYSTEM SYMPTOMS

#### Trouble Diagnosis For Unusual Pressure

INFOID:0000000012876687

Diagnose using a manifold gauge whenever system's high and/or low side pressure(s) is/are unusual. The marker above the gauge scale in the following tables indicates the standard (usual) pressure range.

#### Symptom Table

INFOID:0000000012876688

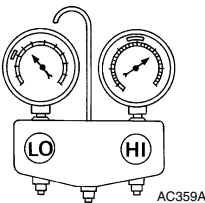
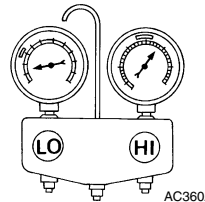
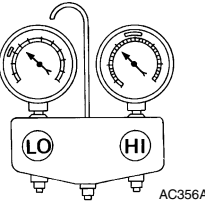
Gauge indication	Refrigerant cycle	Probable cause	Corrective action
<p>Both high and low pressure sides are too high.</p>  <p>AC359A</p>	<p>The pressure returns to normal soon after sprinkling water on condenser.</p>	<p>Overfilled refrigerant.</p>	<p>Recover refrigerant, evacuate system, and recharge with the specified amount of refrigerant. Refer to <a href="#">HA-22, "Recycle Refrigerant"</a>.</p>
	<p>Air flow to condenser is insufficient.</p>	<p>Insufficient condenser cooling performance.</p> <ul style="list-style-type: none"> <li>Poor cooling fan rotation.</li> <li>Improper installation of air guides.</li> <li>Clogged or dirty condenser fins.</li> </ul>	<ul style="list-style-type: none"> <li>Repair or replace malfunctioning parts.</li> <li>Clean and repair condenser fins.</li> </ul>
	<p>When compressor is stopped, a high-pressure reading quickly drops by approximately 196 kPa (2 kg/cm<sup>2</sup>, 28 psi). It then gradually decreases.</p>	<p>Air mixed with refrigerant.</p>	<p>Recover refrigerant, evacuate system, and recharge with the specified amount of refrigerant. Refer to <a href="#">HA-22, "Recycle Refrigerant"</a>.</p>
	<ul style="list-style-type: none"> <li>Low-pressure pipe is cooler than the outlet of evaporator.</li> <li>Low-pressure pipe is frosted.</li> </ul>	<p>Expansion valve opened too much (excessive flow of refrigerant).</p>	<p>Replace expansion valve.</p>
<p>High-pressure side is excessively high and low-pressure side is too low.</p>  <p>AC360A</p>	<p>High-pressure pipe and upper side of condenser become hot, however, liquid tank does not become so hot.</p>	<p>Clogged or crushed high-pressure pipe located between compressor and condenser.</p>	<p>Repair or replace the malfunctioning parts.</p>
<p>High-pressure side is too low and low-pressure side is too high.</p>  <p>AC356A</p>	<ul style="list-style-type: none"> <li>The readings of both sides become equal soon after compressor operation stops.</li> <li>There is no temperature difference between high and low-pressure sides.</li> </ul>	<p>Malfunction in compressor system (insufficient compressor pressure operation).</p> <ul style="list-style-type: none"> <li>Damage or breakage of valve.</li> <li>Malfunctioning gaskets.</li> </ul>	<p>Replace compressor. Refer to <a href="#">HA-29, "COMPRESSOR : Removal and Installation"</a>.</p>

# REFRIGERATION SYSTEM SYMPTOMS

## < SYMPTOM DIAGNOSIS >

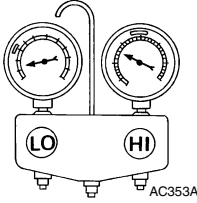
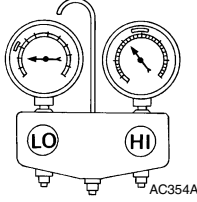
Gauge indication	Refrigerant cycle	Probable cause	Corrective action
<p>Both high and low pressure sides are too low.</p> 	<ul style="list-style-type: none"> <li>The area around evaporator outlet does not become cold.</li> <li>The area around evaporator inlet becomes frosted.</li> </ul>	<ul style="list-style-type: none"> <li>Clogged expansion valve.</li> <li>Breakage of temperature sensor.</li> <li>Clogging by foreign material.</li> </ul>	Eliminate foreign material from expansion valve or replace it.
	<ul style="list-style-type: none"> <li>There is a temperature difference between the areas around outlet and inlet pipes of liquid tank.</li> <li>Liquid tank becomes frosted.</li> </ul>	Malfunction inside liquid tank (clogged strainer).	Replace condenser (includes liquid tank). Refer to <a href="#">HA-36, "Removal and Installation"</a> .
	Evaporator becomes frosted.	<ul style="list-style-type: none"> <li>Clogged or crushed low-pressure pipe.</li> <li>Malfunction in intake air temperature sensor.</li> </ul>	<ul style="list-style-type: none"> <li>Repair or replace malfunctioning parts.</li> <li>Check intake sensor system. Refer to <a href="#">HAC-53, "Diagnosis Procedure"</a>.</li> </ul>
	There is a small temperature difference between the high and low pressure pipes for refrigerant cycle.	<ul style="list-style-type: none"> <li>Low refrigerant charge.</li> <li>Leak or leaks in A/C system.</li> </ul>	<ul style="list-style-type: none"> <li>Check for leaks. Refer to <a href="#">HA-20, "Leak Test"</a>.</li> <li>Recover refrigerant, evacuate system, and recharge with the specified amount of refrigerant. Refer to <a href="#">HA-22, "Recycle Refrigerant"</a>.</li> </ul>
<p>Low-pressure side sometimes becomes negative.</p> 	<ul style="list-style-type: none"> <li>Sometimes the area around evaporator outlet does not become cold.</li> <li>Sometimes the area around evaporator inlet is frosted.</li> </ul>	<ul style="list-style-type: none"> <li>Icing caused by moisture mixed with refrigerant.</li> <li>Deteriorated dryer material in liquid tank.</li> </ul>	<ul style="list-style-type: none"> <li>Recover refrigerant then replace condenser (includes liquid tank). Refer to <a href="#">HA-36, "Removal and Installation"</a>.</li> <li>Evacuate system and recharge with the specified amount of refrigerant. Refer to <a href="#">HA-22, "Charge Refrigerant"</a>.</li> </ul>
Hunting in high-pressure side.	There is no temperature difference between high and low-pressure sides.	Malfunctioning variable valve in compressor.	<ul style="list-style-type: none"> <li>Replace compressor. Refer to <a href="#">HA-29, "COMPRESSOR : Removal and Installation"</a>.</li> <li>Check ECV system.</li> </ul>

# NOISE

< SYMPTOM DIAGNOSIS >

## NOISE

### Symptom Table

INFOID:000000012876689

Symptom	Noise source	Probable cause	Corrective action
Unusual noise from compressor when A/C is ON.	Inside of compressor	Worn, broken, or clogged internal components.	Check compressor oil. Refer to <a href="#">HA-24. "Inspection"</a> .
	Magnet clutch	Contact of clutch disc with pulley.	Check clearance between clutch disc and pulley.
	Compressor body	Loose compressor mounting bolts.	Check torque of mounting bolts. Refer to <a href="#">HA-29. "Exploded View"</a> .
Unusual noise from cooler piping.	Cooler piping (pipe and flexible hose)	Improper installation of clip and bracket.	Check installation of cooler piping. Refer to <a href="#">HA-33. "Exploded View"</a> .
Unusual noise from expansion valve when A/C is ON.	Expansion valve	Low refrigerant charge.	<ul style="list-style-type: none"> <li>Check for leaks. Refer to <a href="#">HA-20. "Leak Test"</a>.</li> <li>Recover refrigerant, evacuate system, and recharge with the specified amount of refrigerant. Refer to <a href="#">HA-22. "Recycle Refrigerant"</a>.</li> </ul>
		Worn, broken, or clogged internal components.	Eliminate foreign material from expansion valve or replace it.
Unusual noise from belt.	—	Loose belt.	Check belt tension. Refer to <a href="#">EM-14. "Checking Drive Belt"</a> .
		Damaged or broken components inside compressor.	Replace compressor. Refer to <a href="#">HA-29. "COMPRESSOR : Removal and Installation"</a> .

A  
B  
C  
D  
E  
F  
G  
H  
HA  
J  
K  
L  
M  
N  
O  
P

# REFRIGERANT

< PERIODIC MAINTENANCE >

## PERIODIC MAINTENANCE

### REFRIGERANT

Description

INFOID:000000012876690

#### CONNECTION OF SERVICE TOOLS AND EQUIPMENT

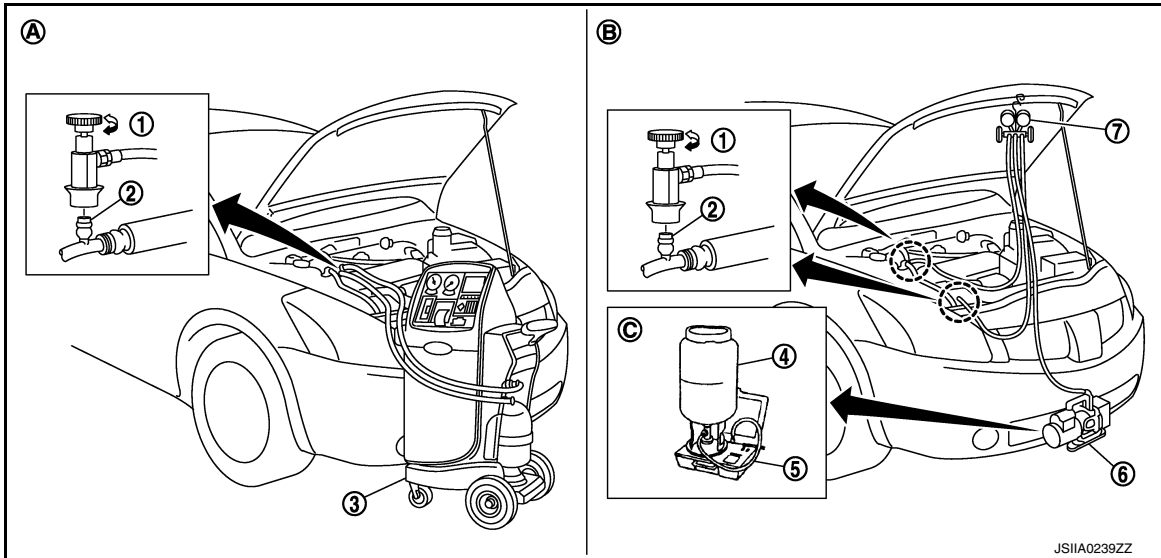

- |                                     |                       |  |
|-------------------------------------|-----------------------|--|
| 1. Shut-off valve                   | 2. A/C service valve  | 3. Recovery/recycling/recharging equipment |
| 4. Refrigerant container (HFC-134a) | 5. Weight scale       | 6. Vacuum pump                             |
| 7. Manifold gauge set               |                       |  |
| A. Preferred (best) method          | B. Alternative method | C. For charging                            |

#### Leak Test

INFOID:000000012876691

#### CHECK REFRIGERANT LEAKS USING FLUORESCENT LEAK DETECTION DYE

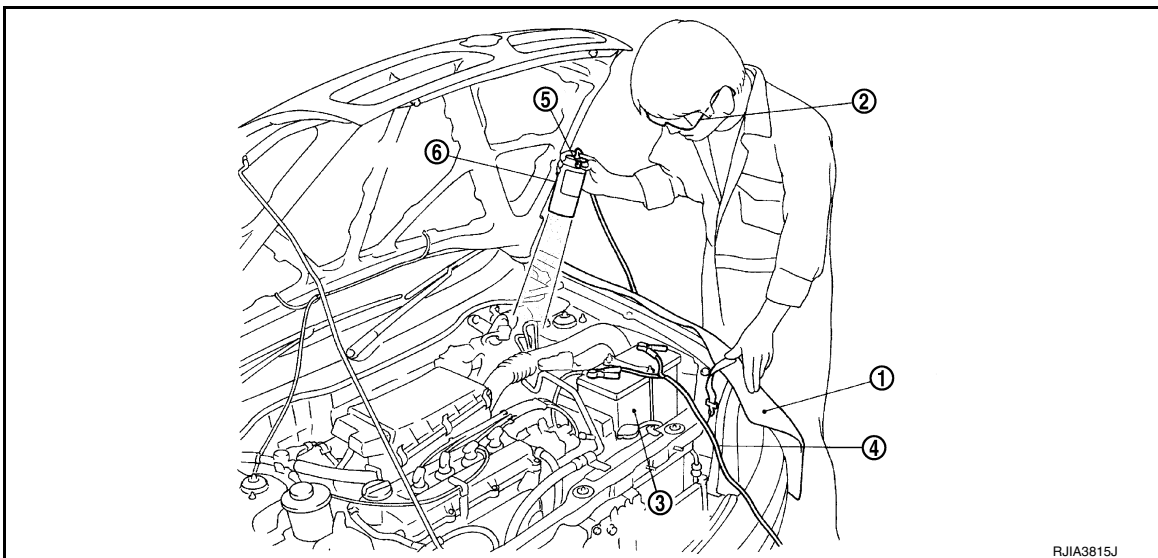

1. Install a fender cover (1).
2. Wear UV safety goggles (2) provided with refrigerant dye leak detection kit.
3. Connect power cable (4) of UV lamp (6) to positive and negative terminals of the battery (3).

# REFRIGERANT

## < PERIODIC MAINTENANCE >

4. Press UV lamp switch (5) and check A/C system for refrigerant leaks. (Where refrigerant leaks occur, fluorescent leak detection dye appears in green color.)

**WARNING:**

**Do not look directly into UV lamp light source.**

**NOTE:**

- For continuous operating time of UV lamp, follow the manufacturer's operating instructions.
- Illuminate piping joints from different angles using UV lamp and check that there are no leaks.
- Use a mirror in areas that are difficult to see to check for refrigerant leaks.
- Refrigerant leaks from evaporator can be detected by soaking a cotton swab or a similar materials with drain hose water and illuminating it using UV lamp.
- Dust, dirt, and packing materials adhesive used for condenser, evaporator, and other locations may fluoresce. Be careful not to misidentify leaks.

5. Repair or replace parts where refrigerant leaks occur and wipe off fluorescent leak detection dye.

**NOTE:**

Completely wipe off fluorescent leak detection dye from gaps between parts, screw threads, and others using a cotton swab or similar materials.

6. Use a UV lamp to check that no fluorescent leak detection dye remains after finishing work.

**WARNING:**

**Do not look directly into UV lamp light source.**

**NOTE:**

- For continuous operating time of UV lamp, follow the manufacturer's operating instructions.
- Dust, dirt, and packing materials adhesive used for condenser, evaporator, and other locations may fluoresce. Be careful not to misidentify leaks.

## CHECK REFRIGERANT LEAKS USING ELECTRONIC LEAK DETECTOR

**WARNING:**

**Do not check for refrigerant leaks while the engine is running.**

**CAUTION:**

**Be careful of the following items so that inaccurate checks or misidentifications are avoided.**

- **Do not allow refrigerant vapor, shop chemical vapors, cigarette smoke or others around the vehicle.**
- **Always check for refrigerant leaks in a low air flow environment so that refrigerant may not disperse when leaks occur.**

1. Stop the engine.
2. Connect recovery/recycling/recharging equipment or manifold gauge set to A/C service valve.
3. Check that A/C refrigerant pressure is 345 kPa (3.52 kg/cm<sup>2</sup>, 50 psi) or more when temperature is 16°C (61°F) or more. When pressure is lower than the specified value, recycle refrigerant completely and fill refrigerant to the specified level.

**NOTE:**

Leaks may not be detected if A/C refrigerant pressure is 345 kPa (3.52 kg/cm<sup>2</sup>, 50 psi) or less when temperature is less than 16°C (61°F).

4. Clean area where refrigerant leak check is performed and check for refrigerant leaks along all surfaces of pipe connections and A/C system components using electronic leak detector probe.

**CAUTION:**

- **Continue checking when a leak is found. Always continue and complete checking along all pipe connections and A/C system components for additional leaks.**
- **When a leak is detected, clean leak area using compressed air and check again.**
- **When checking for leaks inside the cooling unit, always clean inside the drain hose so that the probe surface may not be exposed to water or dirt.**

**NOTE:**

- Always check for leaks starting from high-pressure side and continuing to low-pressure side.
- When checking for leaks inside the cooling unit, operate blower fan motor for 15 minutes or more at the maximum fan speed while the engine is stopped, and then insert electrical leak detector probe into drain hose and hold for 10 minutes or more.
- When disconnecting shut-off valve that is connected to A/C service valve, always evacuate remaining refrigerant so that misidentification can be avoided.

5. Repair or replace parts where refrigerant leaks are detected.
6. Start the engine and set A/C control in the following conditions:
  - A/C switch ON

# REFRIGERANT

## < PERIODIC MAINTENANCE >

- Air flow: VENT (ventilation)
  - Intake door position: Recirculation
  - Temperature setting: Full cold
  - Fan (blower) speed: Maximum speed set
7. Run the engine at approximately 1,500 rpm for 2 minutes or more.
  8. Stop the engine. Check again for refrigerant leakage. Go to step 4.

### **WARNING:**

**Be careful not to get burned when the engine is hot.**

### **NOTE:**

- Start refrigerant leak check immediately after the engine is stopped.
- When refrigerant circulation is stopped, pressure on the low-pressure side rises gradually, and after this, pressure on the high-pressure side falls gradually.
- The higher the pressure is, the easier it is to find the refrigerant leaks.

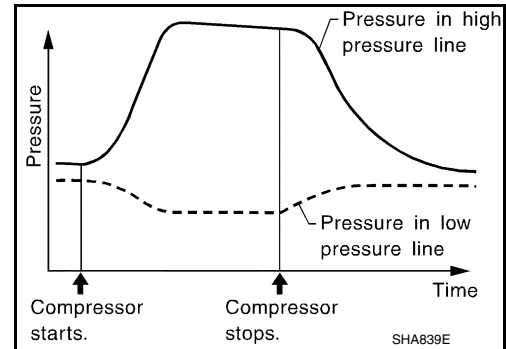

## Recycle Refrigerant

INFOID:0000000012876692

### **WARNING:**

- Always use HFC-134a for A/C refrigerant. If CFC-12 is accidentally charged, compressor is damaged due to insufficient lubrication.
  - Always observe and follow precautions described on refrigerant container. Incorrect handling may result in an explosion of refrigerant container, frostbite or the loss of eyesight.
  - Do not breathe A/C refrigerant and oil vapor or mist. Exposure may irritate eyes, nose, or throat.
  - Do not allow HFC-134a to be exposed to an open flame or others because it generates poisonous gas when in contact with high temperature objects. Keep workshop well-ventilated.
1. Perform oil return operation. Refer to [HA-24, "Perform Oil Return Operation"](#). (If refrigerant or oil leaks are detected in large amounts, omit this step and go to step 2.)

### **CAUTION:**

**Do not perform oil return operation if a large amount of refrigerant or oil leaks are detected.**

2. Check gauge pressure readings of recovery/recycling/recharging equipment. When remaining pressure exists, recycle refrigerant from high-pressure hose and low-pressure hose.

### **NOTE:**

Follow manufacturer's instructions for the handling or maintenance of the equipment. Do not fill the equipment with non-specified refrigerant.

3. Remove A/C service valve cap from the vehicle.
4. Connect recovery/recycling/recharging equipment to A/C service valve.
5. Operate recovery/recycling/recharging equipment, and recycle refrigerant from the vehicle.
6. Evacuate air for 10 minutes or more to remove any remaining refrigerant integrated in compressor oil, etc.
7. Refrigerant recycle operation is complete.

## Charge Refrigerant

INFOID:0000000012876693

### **WARNING:**

- Always use HFC-134a for A/C refrigerant. If CFC-12 is accidentally charged, compressor is damaged due to insufficient lubrication.
  - Always observe and follow precautions described on refrigerant container. Incorrect handling may result in an explosion of refrigerant container, frostbite, or the loss of eyesight.
  - Do not breathe A/C refrigerant and oil vapor or mist. Exposure may irritate eyes, nose, or throat.
  - Do not allow HFC-134a to be exposed to an open flame or others because it generates poisonous gas when in contact with high temperature objects. Keep workshop well-ventilated.
1. Connect recovery/recycling/recharging equipment to the A/C service valve.

# REFRIGERANT

## < PERIODIC MAINTENANCE >

2. Operate recovery/recycling/recharging equipment, and evacuate air from A/C system for 25 minutes or more.  
**CAUTION:**  
**Evacuate air for 15 minutes or more if the parts are replaced.**
3. Check the airtightness of A/C system for 25 minutes or more. If pressure rises more than the specified level, charge A/C system with approximately 200g refrigerant and check that there are no refrigerant leaks. Refer to [HA-20. "Leak Test"](#).  
**CAUTION:**  
**Check the airtightness for 15 minutes or more if the parts are replaced.**
4. If parts other than compressor are replaced, fill compressor oil according to parts that are replaced.
5. Charge the specified amount of refrigerant to A/C system.
6. Check that A/C system operates normally.
7. Disconnect the recovery/recycling/recharging equipment. (Collect the refrigerant from the high-pressure hose and low-pressure hose of recovery/recycling/recharging equipment.)
8. Install the A/C service valve cap.
9. Refrigerant charge is complete.

A  
B  
C  
D  
E  
F  
G  
H  
HA  
J  
K  
L  
M  
N  
O  
P

# OIL

< PERIODIC MAINTENANCE >

## OIL

### Description

INFOID:000000012876694

#### MAINTENANCE OF OIL LEVEL

The compressor oil is circulating in the system together with the refrigerant. It is necessary to fill compressor with oil when replacing A/C system parts or when a large amount of refrigerant leaks are detected. It is important to always maintain oil level within the specified level or the following conditions may occur:

- Insufficient oil amount: Stuck compressor
- Excessive oil amount: Insufficient cooling (caused by insufficient heat exchange)

**Oil Type : ND-OIL8 (PAG)**

### Inspection

INFOID:000000012876695

If a compressor is malfunctioning (internal noise, insufficient cooling), check the compressor oil.

#### 1. COMPRESSOR OIL JUDGMENT

1. Remove the compressor. Refer to [HA-29, "COMPRESSOR : Removal and Installation"](#).
2. Sample compressor oil and judge according to the figure below.

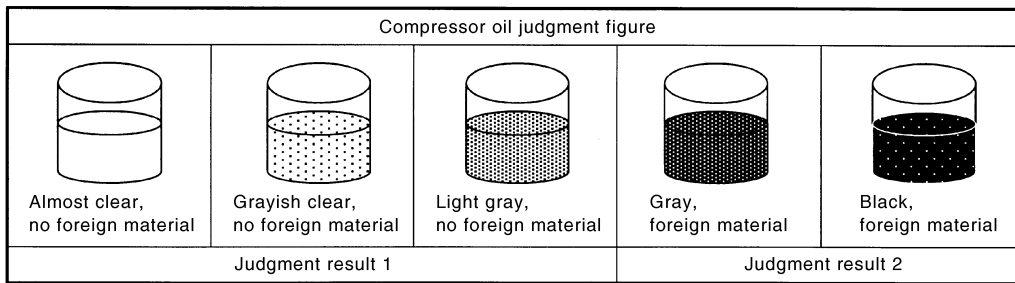

JSIIA0927GB

Judgment result 1>> Replace compressor only.

Judgment result 2>> Replace compressor and condenser (includes liquid tank).

### Perform Oil Return Operation

INFOID:000000012876696

#### CAUTION:

**If a large amount of refrigerant or oil leaks are detected, do not perform oil return operation.**

1. Start the engine and set to the following conditions:
  - Engine speed: Idling to 1,200 rpm
  - A/C switch: ON
  - Fan (blower) speed: Maximum speed set
  - Intake door position: Recirculation
  - Temperature setting: Full cold
2. Perform oil return operation for approximately 10 minutes.
3. Stop the engine.
4. Oil return operation is complete.

### Oil Adjusting Procedure for Components Replacement Except Compressor

INFOID:000000012876697

Fill with oil to the amount that is calculated according to the following conditions.

Example: Oil amount to be added when replacing evaporator [m ℓ (US fl oz, Imp fl oz)] = 75 (2.5, 2.6) + α

Conditions	Oil amount to be added to A/C system m ℓ (US fl oz, Imp fl oz)
Replace evaporator	75 (2.5, 2.6)
Replace condenser (includes liquid tank)	80 (2.7, 2.8)



# OIL

## < PERIODIC MAINTENANCE >

Conditions		Oil amount to be added to A/C system m ℓ (US fl oz, Imp fl oz)
Refrigerant leak is detected	Large amount leak	30 (1.0, 1.1)
	Small amount leak	—
Oil amount that is recycled together with refrigerant during recycle operation		α

## Oil Adjusting Procedure for Compressor Replacement

INFOID:0000000012876698

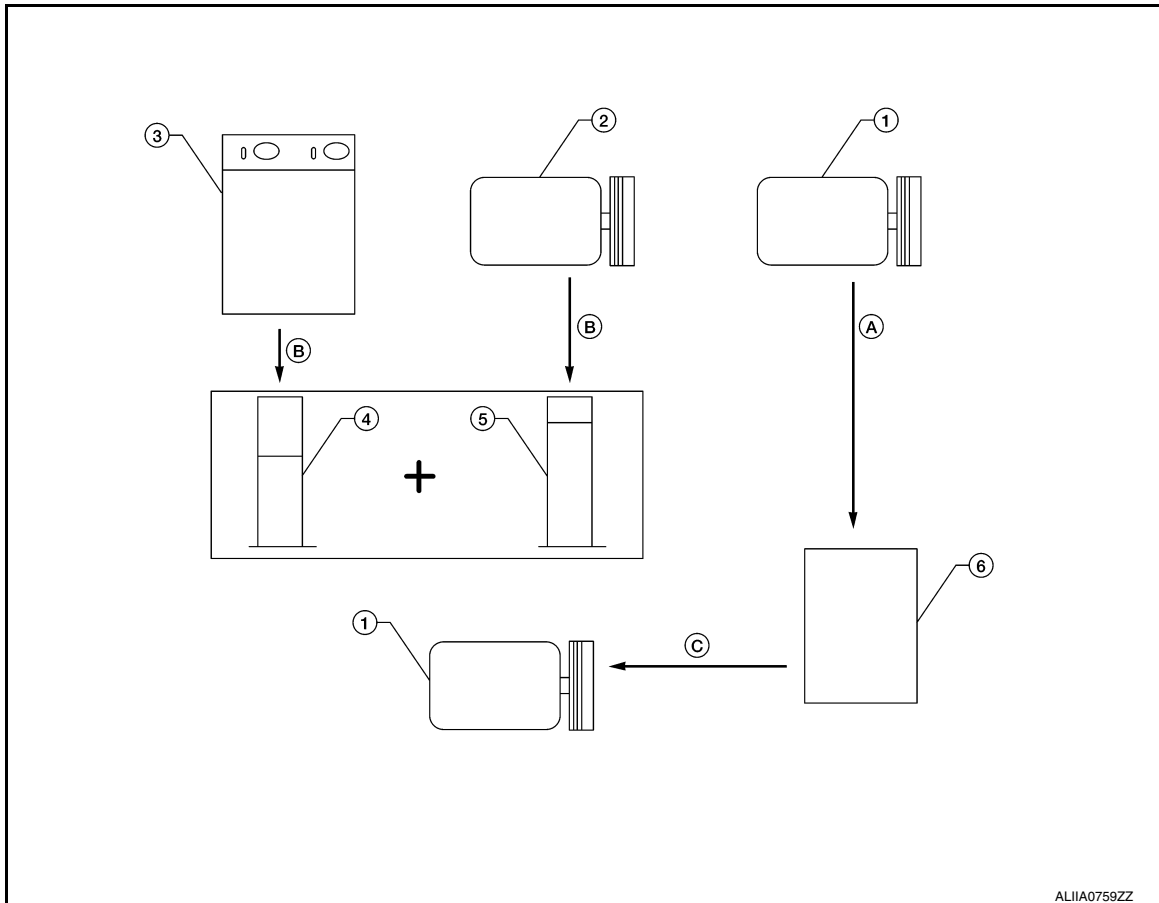

- |   |                                   |  |
|---|-----------------------------------|--|
| 1. New compressor   | 2. Old compressor                 | 3. Recovery/recycling equipment  |
| 4. Measuring cup X  | 5. Measuring cup Y                | 6. New oil   |
| A. Drain oil from the new compressor into clean container | B. Record amount of oil recovered | C. Install new oil equal to recorded amounts in measuring cups X and Y |

- Before connecting recovery/recycling/recharging equipment to vehicle, check recovery/recycling/recharging equipment gauges. No refrigerant pressure should be displayed. If NG, recover refrigerant from equipment lines.
- Connect recovery/recycling/recharging equipment to vehicle. Confirm refrigerant purity in supply tank using recovery/recycling/recharging equipment and refrigerant identifier. If NG, refer to [HA-4, "Precautions For Refrigerant System Service"](#).
- Confirm refrigerant purity in vehicle A/C system using recovery/recycling equipment and refrigerant identifier. If NG, refer to [HA-4, "Precautions For Refrigerant System Service"](#).
- Discharge refrigerant into the refrigerant recovery/recycling equipment. Measure oil discharged into the recovery/recycling/recharging equipment.
- Drain the oil from the old (removed) compressor into a graduated container and recover the amount of oil drained.
- Drain the oil from the new compressor into a separate, clean container.

## OIL

### < PERIODIC MAINTENANCE >

---

7. Measure the amount of new oil installed equal to amount drained from old compressor. Add this oil to new compressor through the suction port opening.
8. Measure the amount of new oil equal to the amount recovered during discharging. Add this oil to new compressor through the suction port opening.

# PERFORMANCE TEST

< PERIODIC MAINTENANCE >

## PERFORMANCE TEST

### Inspection

INFOID:000000012876699

#### INSPECTION PROCEDURE

1. Connect recovery/recycling/recharging equipment (for HFC-134a) or manifold gauge.
2. Start the engine, and set to the following conditions.

Test condition		
Surrounding condition		Indoors or in the shade (in a well-ventilated place)
Vehicle condition	Door	Closed
	Door glass	Full open
	Hood	Open
	Engine speed	Idle speed
A/C condition	Temperature control switch or dial	Full cold
	A/C switch	ON
	Air outlet	VENT (ventilation)
	Intake door position	Recirculation
	Fan (blower) speed	Maximum speed set

3. Maintain test condition until A/C system becomes stable (approximately 10 minutes).
4. Check that test results of "recirculating-to-discharge air temperature" and "ambient air temperature-to-operating pressure" are within the specified value.
5. When test results are within the specified value, inspection is complete.  
If any test result is out of the specified value, perform diagnosis by gauge pressure. Refer to [HA-17](#), "[Symptom Table](#)".

#### RECIRCULATING-TO-DISCHARGE AIR TEMPERATURE TABLE

Inside air (Recirculating air) at blower assembly inlet		Discharge air temperature from center ventilator °C (°F)
Relative humidity %	Air temperature °C (°F)	
50 – 60	20 (68)	4.7 – 6.7 (40 – 44)
	25 (77)	8.6 – 11.1 (47 – 52)
	30 (86)	12.6 – 15.6 (55 – 60)
	35 (95)	19.0 – 22.5 (66 – 73)
60 – 70	20 (68)	6.7 – 8.7 (44 – 48)
	25 (77)	11.1 – 13.6 (52 – 56)
	30 (86)	15.6 – 18.6 (60 – 65)
	35 (95)	22.5 – 26.0 (73 – 79)

#### AMBIENT AIR TEMPERATURE-TO-OPERATING PRESSURE TABLE

## PERFORMANCE TEST

< PERIODIC MAINTENANCE >

Fresh air		High-pressure (Discharge side) kPa (kg/cm <sup>2</sup> , psi)	Low-pressure (Suction side) kPa (kg/cm <sup>2</sup> , psi)
Relative humidity %	Air temperature °C (°F)		
50 – 70	25 (77)	909 – 1,112 (9.2 – 11.3, 131.8 – 161.2)	159 – 194 (1.6 – 2.0, 23.1 – 28.1)
	30 (86)	1,073 – 1,312 (10.9 – 13.4, 155.6 – 190.2)	211 – 259 (2.2 – 2.6, 30.6 – 37.6)
	35 (95)	1,445 – 1,766 (14.7 – 18.0, 209.5 – 256.1)	247 – 300 (2.5 – 3.1, 35.8 – 43.5)
	40 (104)	1,650 – 2,017 (16.8 – 20.6, 239.3 – 292.5)	290 – 355 (3.0 – 3.6, 42.1 – 51.5)

# COMPRESSOR

< REMOVAL AND INSTALLATION >

## REMOVAL AND INSTALLATION

### COMPRESSOR

Exploded View

INFOID:000000012876700

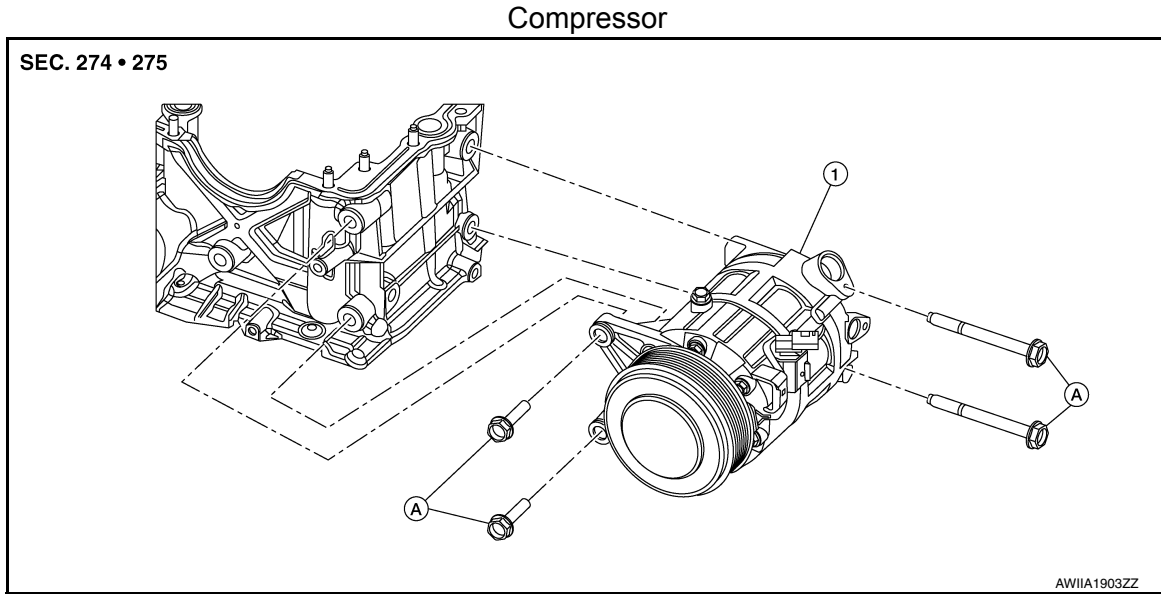

1. Compressor

A. Refer to INSTALLATION

### Magnet Clutch Assembly

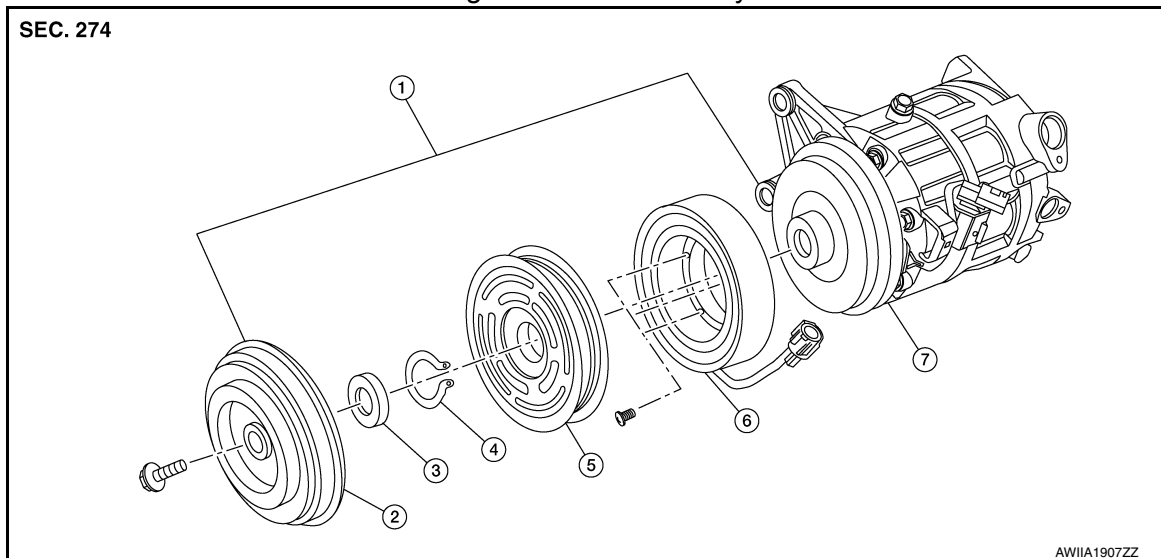

1. Magnet clutch assembly

2. Clutch disc

3. Shim

4. Snap ring

5. Pulley

6. Magnet coil

7. Compressor

## COMPRESSOR

### COMPRESSOR : Removal and Installation

INFOID:000000012876701

#### REMOVAL

# COMPRESSOR

## < REMOVAL AND INSTALLATION >

1. Discharge the refrigerant. Refer to [HA-22, "Recycle Refrigerant"](#).
2. Partially remove the front edge of the front fender protector (RH). Refer to [EXT-36, "FENDER PROTECTOR : Removal and Installation"](#).
3. Remove the bolts that retain the oil cooler line brackets to the engine block and reposition the oil cooler line aside. Refer to [LU-15, "Removal and Installation"](#).
4. Remove the drive belt. Refer to [EM-14, "Removal and Installation"](#).
5. Disconnect the harness connector from the compressor.
6. Disconnect the low-pressure flexible hose from the compressor.  
**CAUTION:**  
**Cap or wrap the joint of the pipe with suitable material such as vinyl tape to avoid the entry of air.**
7. Disconnect the high-pressure flexible hose from the compressor.  
**CAUTION:**  
**Cap or wrap the joint of the pipe with suitable material such as vinyl tape to avoid the entry of air.**
8. Remove the compressor bolts then remove the compressor.

## INSTALLATION

1. Installation is in the reverse order of removal.  
**CAUTION:**
  - Tighten the compressor bolts in the specified sequence.
  - Do not reuse O-rings.
  - Apply A/C oil to the O-rings on the compressor for installation.

**Bolts (1,2) : 55.0 N·m (5.6 Kg-m, 41 ft-lb)**

**Bolts (3,4) : 61.3 N·m (6.3 Kg-m, 45 ft-lb)**

### **CAUTION:**

- After charging refrigerant, check for leaks. Refer to [HA-20, "Leak Test"](#).
- Check the tension of the drive belt after installing the compressor. Refer to [EM-14, "Checking Drive Belt"](#).

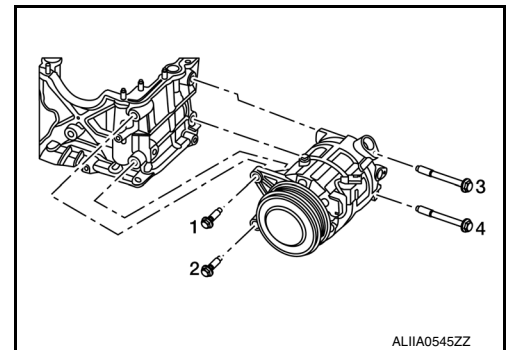

## MAGNET CLUTCH

### MAGNET CLUTCH : Removal and Installation of Compressor Clutch

INFOID:000000012876702

#### REMOVAL

1. Remove the compressor. Refer to [HA-29, "COMPRESSOR : Removal and Installation"](#).
2. Remove the center bolt by holding the clutch disc steady using a suitable tool.
3. Remove the clutch disc and shim.  
**CAUTION:**  
**Retain all the shims for installation.**
4. Remove the snap ring using a suitable tool as shown.

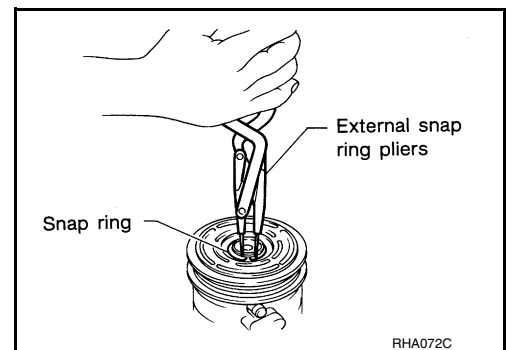

# COMPRESSOR

## < REMOVAL AND INSTALLATION >

5. Remove the pulley assembly using a suitable tool (A) as shown.

**CAUTION:**

To prevent deformation of the pulley groove, the puller claws should be hooked under (not into) the pulley groove.

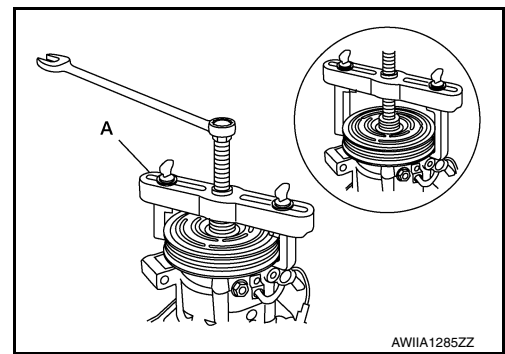

6. Disconnect the harness connector from the magnet coil.  
7. Remove the three magnet coil screws using a suitable tool as shown then remove the magnet coil.

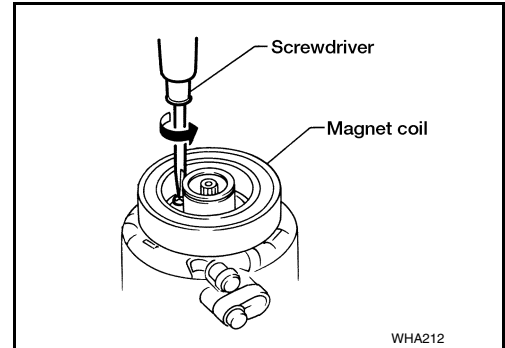

## INSPECTION AFTER REMOVAL

- (1): Shim
- (2): Snap ring
- (3): Clutch disc
- (4): Pulley
- (5): Magnet coil
- (A): Center bolt
- (B): Magnet coil screws

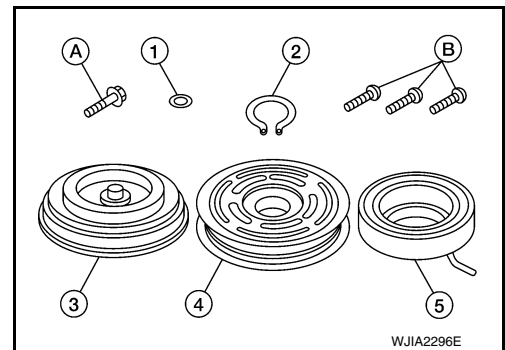

### Clutch Disc

If the contact surface shows signs of damage due to excessive heat, replace as necessary.

### Pulley

Check the appearance of the pulley assembly. If the contact surface of the pulley shows signs of excessive grooving, replace as necessary. The contact surfaces of the pulley assembly should be cleaned with a suitable solvent before installation.

### Magnet Coil

Check the magnet coil for a loose connection or cracked insulation. Replace as necessary.

## INSTALLATION

1. Install the magnet coil by aligning the magnet coil pin (A) with the hole (B) in the compressor front head as shown then install the magnet coil screws.

- ←: Vehicle rear

**CAUTION:**

- Be sure to align the magnet coil pin with the hole in the compressor front head.

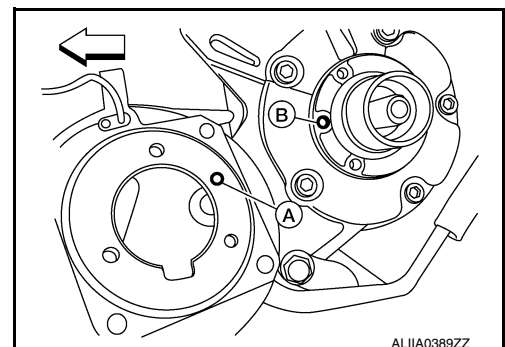

A  
B  
C  
D  
E  
F  
G  
H  
HA  
J  
K  
L  
M  
N  
O  
P

# COMPRESSOR

## < REMOVAL AND INSTALLATION >

2. Connect the magnet coil harness.
3. Install the pulley assembly using Tool and a wrench as shown then install the snap ring using a suitable tool.

**Tool number** : — (J-38873-A)

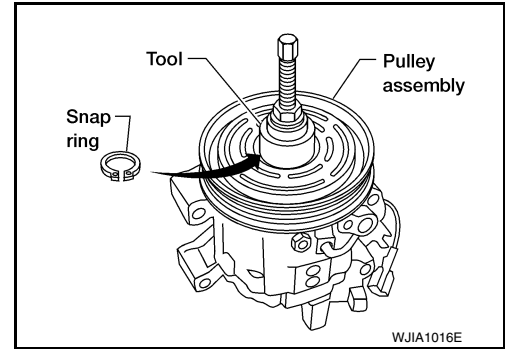

4. Install the clutch disc (1) on the drive shaft together with all of the original shim(s) (2) using a suitable tool (A).

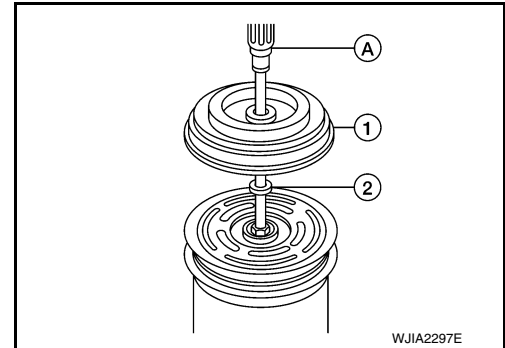

5. Install the center bolt using a suitable tool.
6. Install the compressor. Refer to [HA-29, "COMPRESSOR : Removal and Installation"](#).

### INSPECTION AFTER INSTALLATION

Check the clearance (B) all the way around between the clutch disc (1) and pulley (2) using a suitable tool (A) as shown.

**Clutch disc-to-pulley clearance (B)** : Refer to [HA-46, "Compressor"](#).

If the specified clearance (B) is not obtained, replace the adjusting shims and recheck the clearance (B) as shown.

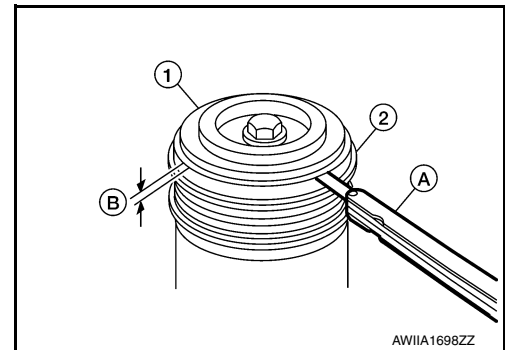

### BREAK-IN OPERATION

When replacing compressor clutch assembly, always conduct the break-in operation. This is done by engaging and disengaging the clutch about 30 times. Break-in operation raises the level of transmitted torque.



# COOLER PIPE AND HOSE

< REMOVAL AND INSTALLATION >

## COOLER PIPE AND HOSE

### Exploded View

INFOID:000000012876703

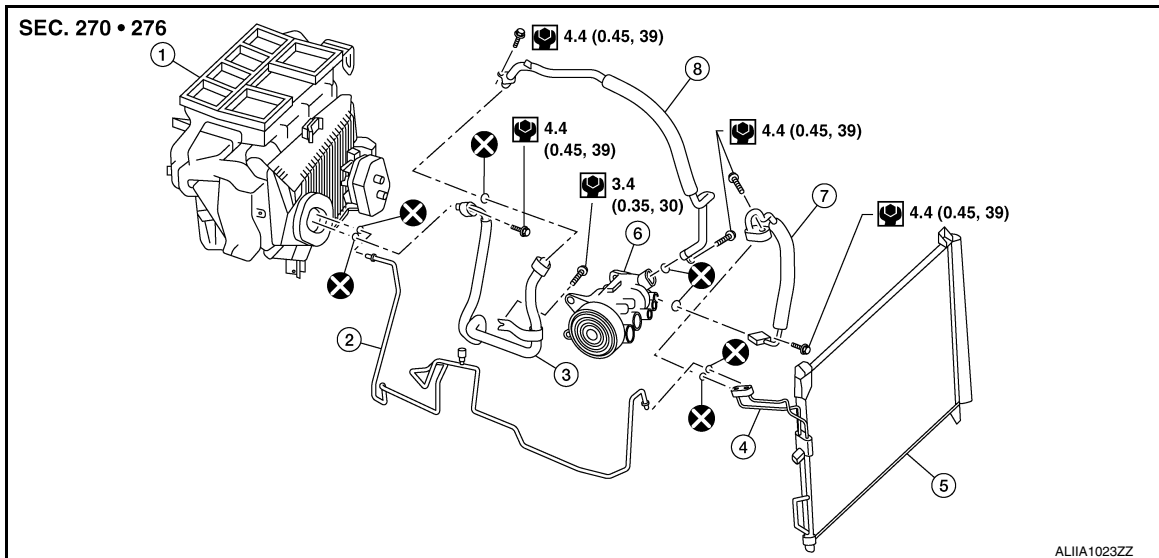

- |                                      |                               |                      |
|--------------------------------------|-------------------------------|----------------------|
| 1. Heating and cooling unit assembly | 2. High-pressure pipe         | 3. Low-pressure pipe |
| 4. Condenser pipe assembly           | 5. Condenser                  | 6. Compressor        |
| 7. High-pressure flexible hose       | 8. Low-pressure flexible hose |                      |

## HIGH-PRESSURE AND LOW-PRESSURE PIPE

### HIGH-PRESSURE AND LOW-PRESSURE PIPE : Removal and Installation

INFOID:000000012876704

#### REMOVAL

1. Discharge the refrigerant. Refer to [HA-22, "Recycle Refrigerant"](#).
2. Remove the power steering oil pump assembly. Refer to [ST-38, "Removal and Installation"](#).
3. Remove the washer tank. Refer to [WW-52, "Removal and Installation"](#).
4. Remove the core support cover. Refer to [CO-12, "Exploded View"](#).
5. Remove the front air duct. Refer to [EM-26, "Removal and Installation"](#).
6. Remove the front under cover. Refer to [EXT-40, "FRONT UNDER COVER : Removal and Installation"](#).
7. Remove the cowl top extension. Refer to [EXT-34, "Exploded View"](#).
8. Remove the high-pressure and low-pressure pipe bolt from the expansion valve.  
**CAUTION:**  
**Cap or wrap the joint of the pipe with suitable material such as vinyl tape to avoid the entry of air.**
9. Remove the high-pressure and low-pressure pipe bolt from the underfloor rear high-pressure and low-pressure A/C pipes.  
**CAUTION:**  
**Cap or wrap the joint of the pipe with suitable material such as vinyl tape to avoid the entry of air.**
10. Remove the high-pressure and low-pressure pipe bolt from the low-pressure flexible hose and high-pressure pipe.  
**CAUTION:**  
**Cap or wrap the joint of the pipe with suitable material such as vinyl tape to avoid the entry of air.**
11. Remove the high-pressure and low-pressure pipe.

#### INSTALLATION

Installation is in the reverse order of removal.

#### **CAUTION:**

- Do not reuse O-rings.

# COOLER PIPE AND HOSE

## < REMOVAL AND INSTALLATION >

- Apply A/C oil to the O-rings of the high-pressure and low-pressure pipe for installation.
- After charging refrigerant, check for leaks. Refer to [HA-20, "Leak Test"](#).

### LOW-PRESSURE FLEXIBLE HOSE

#### LOW-PRESSURE FLEXIBLE HOSE : Removal and Installation

INFOID:0000000012876705

##### REMOVAL

1. Discharge the refrigerant. Refer to [HA-22, "Recycle Refrigerant"](#).
2. Remove the front under cover. Refer to [EXT-40, "Exploded View"](#).
3. Remove the low-pressure flexible hose bolt from the high-pressure and low-pressure pipe.  
**CAUTION:**  
**Cap or wrap the joint of the pipe with suitable material such as vinyl tape to avoid the entry of air.**
4. Remove the low-pressure flexible hose bolt from the compressor.  
**CAUTION:**  
**Cap or wrap the joint of the pipe with suitable material such as vinyl tape to avoid the entry of air.**
5. Remove the low-pressure flexible hose.

##### INSTALLATION

Installation is in the reverse order of removal.

##### **CAUTION:**

- Do not reuse O-rings.
- Apply A/C oil to the O-rings of the low-pressure flexible hose for installation.
- After charging refrigerant, check for leaks. Refer to [HA-20, "Leak Test"](#).

### HIGH-PRESSURE PIPE

#### HIGH-PRESSURE PIPE : Removal and Installation

INFOID:0000000012876706

##### REMOVAL

1. Discharge the refrigerant. Refer to [HA-22, "Recycle Refrigerant"](#).
2. Remove the core support cover. Refer to [CO-12, "Exploded View"](#).
3. Remove the front air duct. Refer to [EM-26, "Removal and Installation"](#).
4. Remove the front under cover. Refer to [EXT-40, "FRONT UNDER COVER : Removal and Installation"](#).
5. Remove the high-pressure pipe bolt from the high-pressure and low-pressure pipe.  
**CAUTION:**  
**Cap or wrap the joint of the pipe with suitable material such as vinyl tape to avoid the entry of air.**
6. Remove the high-pressure pipe bolt from the condenser pipe assembly.  
**CAUTION:**  
**Cap or wrap the joint of the pipe with suitable material such as vinyl tape to avoid the entry of air.**
7. Remove the clip that retains the high-pressure pipe.
8. Remove the high-pressure pipe.

##### INSTALLATION

Installation is in the reverse order of removal.

##### **CAUTION:**

- Do not reuse O-rings.
- Apply A/C oil to the O-rings of the high-pressure pipe for installation.
- After charging the refrigerant, check for leaks. Refer to [HA-20, "Leak Test"](#).

### HIGH-PRESSURE FLEXIBLE HOSE

#### HIGH-PRESSURE FLEXIBLE HOSE : Removal and Installation

INFOID:0000000012876707

##### REMOVAL

1. Discharge the refrigerant. Refer to [HA-22, "Recycle Refrigerant"](#).
2. Remove the front air duct. Refer to [EM-26, "Exploded View"](#).
3. Remove the core support cover. Refer to [CO-12, "Exploded View"](#).
4. Remove the front under cover. Refer to [EXT-40, "FRONT UNDER COVER : Removal and Installation"](#).

## COOLER PIPE AND HOSE

### < REMOVAL AND INSTALLATION >

---

5. Remove the high-pressure flexible hose bolt from the condenser pipe assembly.  
**CAUTION:**  
**Cap or wrap the joint of the pipe with suitable material such as vinyl tape to avoid the entry of air.**
6. Remove the high-pressure flexible hose from the compressor.  
**CAUTION:**  
**Cap or wrap the joint of the pipe with suitable material such as vinyl tape to avoid the entry of air.**
7. Remove the high-pressure flexible hose.

### INSTALLATION

Installation is in the reverse order of removal.

#### **CAUTION:**

- Do not reuse O-rings.
- Apply A/C oil to the O-rings of the high-pressure flexible hose for installation.
- After charging the refrigerant, check for leaks. Refer to [HA-20, "Leak Test"](#).

A

B

C

D

E

F

G

H

HA

J

K

L

M

N

O

P

# CONDENSER

< REMOVAL AND INSTALLATION >

## CONDENSER

### Exploded View

INFOID:000000012876708

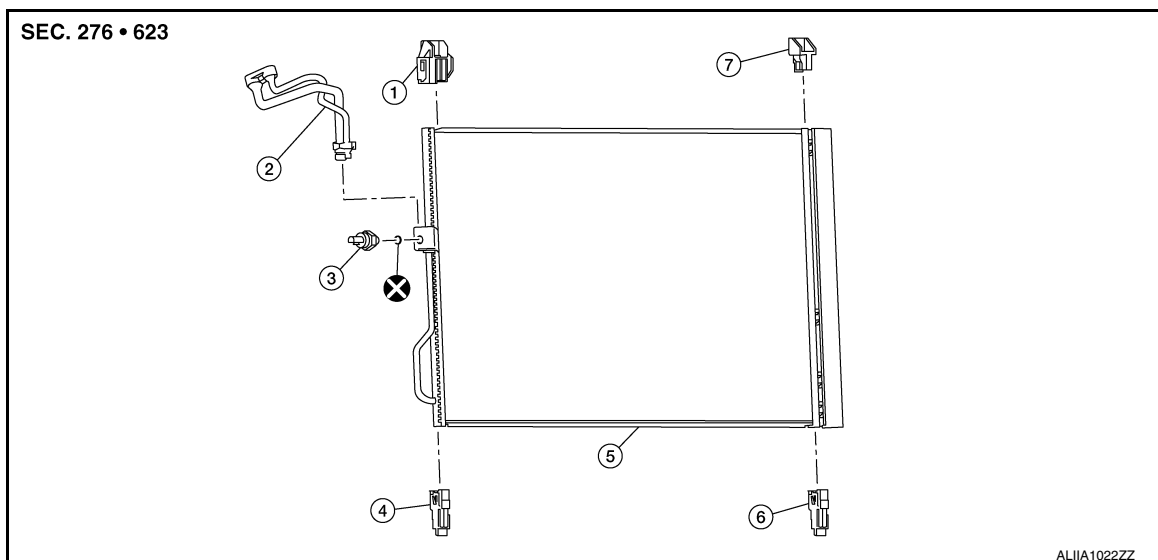

- |                                 |                                     |                                 |
|---------------------------------|-------------------------------------|---------------------------------|
| 1. Condenser upper bracket (RH) | 2. Condenser pipe assembly          | 3. Refrigerant pressure sensor  |
| 4. Condenser lower bracket (RH) | 5. Condenser (includes liquid tank) | 6. Condenser lower bracket (LH) |
| 7. Condenser upper bracket (LH) |                                     |                                 |

### Removal and Installation

INFOID:000000012876709

#### REMOVAL

1. Discharge the refrigerant. Refer to [HA-22, "Recycle Refrigerant"](#).
2. Remove the front air duct. Refer to [EM-26, "Exploded View"](#).
3. Remove the hood lock assembly. Refer to [DLK-316, "HOOD LOCK : Removal and Installation"](#).
4. Disconnect the harness connector from the refrigerant pressure sensor.
5. Remove the radiator core support center brace bolts (A) then remove the radiator core support center brace.

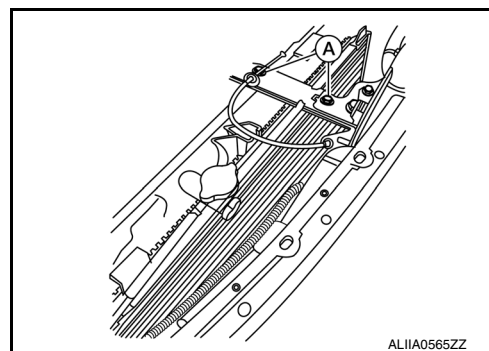

6. Remove the bolt that retains the condenser pipe assembly to the condenser then separate the condenser pipe assembly from the condenser.  
**CAUTION:**  
**Cap or wrap the joint of the pipe with suitable material such as vinyl tape to avoid the entry of air.**
7. Remove the condenser bracket bolts.
8. Remove the condenser.
9. Remove the refrigerant pressure sensor (if necessary). Refer to [HA-40, "Removal and Installation"](#).

#### INSTALLATION

Installation is in the reverse order of removal.

**CAUTION:**

# CONDENSER

## < REMOVAL AND INSTALLATION >

---

- Do not reuse O-rings.
- Apply A/C oil to the O-rings of the condenser for installation.
- After charging the refrigerant, check for leaks. Refer to [HA-20, "Leak Test"](#).

A

B

C

D

E

F

G

H

HA

J

K

L

M

N

O

P

# CONDENSER PIPE ASSEMBLY

< REMOVAL AND INSTALLATION >

## CONDENSER PIPE ASSEMBLY

### Removal and Installation

INFOID:000000012876710

#### REMOVAL

1. Discharge the refrigerant. Refer to [HA-22, "Recycle Refrigerant"](#).
2. Remove the core support cover. Refer to [CO-12, "Exploded View"](#).
3. Remove the front grille. Refer to [EXT-30, "Removal and Installation"](#).
4. Remove the bolt that retains the condenser pipe assembly to the condenser.
5. Remove the bolt (A) that retains the condenser pipe assembly to the high-pressure flexible hose and high-pressure pipe.

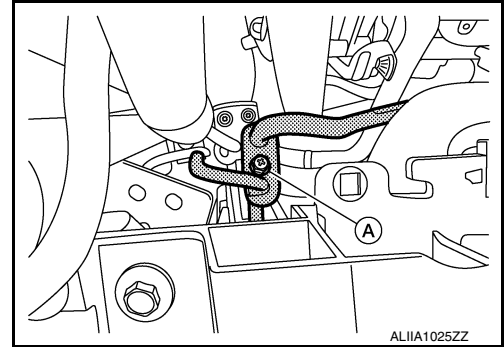

6. Remove the condenser pipe assembly.

**CAUTION:**

Cap or wrap the joint of the pipe with suitable material such as vinyl tape to avoid the entry of air.

#### INSTALLATION

Installation is in the reverse order of removal.

**CAUTION:**

- Do not reuse O-rings.
- Apply A/C oil to the O-rings of the condenser pipe assembly for installation.
- After charging the refrigerant, check for leaks. Refer to [HA-20, "Leak Test"](#).

# LIQUID TANK

< REMOVAL AND INSTALLATION >

## LIQUID TANK

---

### Removal and Installation

INFOID:0000000012876711

The liquid tank is only serviced as part of the condenser. Refer to [HA-36. "Removal and Installation"](#).

- A
- B
- C
- D
- E
- F
- G
- H
- HA**
- J
- K
- L
- M
- N
- O
- P

# REFRIGERANT PRESSURE SENSOR

< REMOVAL AND INSTALLATION >

## REFRIGERANT PRESSURE SENSOR

### Removal and Installation

INFOID:000000012876712

#### REMOVAL

1. Discharge the refrigerant. Refer to [HA-22, "Recycle Refrigerant"](#).
2. Remove the front bumper fascia assembly. Refer to [EXT-25, "Removal and Installation"](#).
3. Remove horn assembly. Refer to [HRN-6, "Removal and Installation"](#).
4. Remove the air guide (RH). Refer to [HA-36, "Exploded View"](#).
5. Disconnect the harness connector from the refrigerant pressure sensor.
6. Remove refrigerant pressure sensor (1).

**CAUTION:**

Cap or wrap the opening of the refrigerant pressure sensor with suitable material such as vinyl tape to avoid the entry of air.

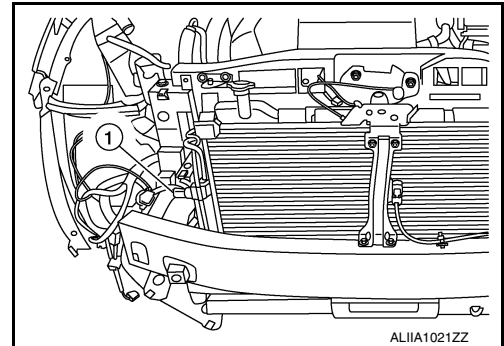

ALIIA1021ZZ

#### INSTALLATION

Installation is in the reverse order of removal.

**CAUTION:**

- Do not reuse the O-ring.
- Apply A/C oil to the O-ring of the refrigerant pressure sensor for installation.
- After charging the refrigerant, check for leaks. Refer to [HA-20, "Leak Test"](#).



# HEATING AND COOLING UNIT ASSEMBLY

< REMOVAL AND INSTALLATION >

## HEATING AND COOLING UNIT ASSEMBLY

Exploded View

INFOID:000000012876713

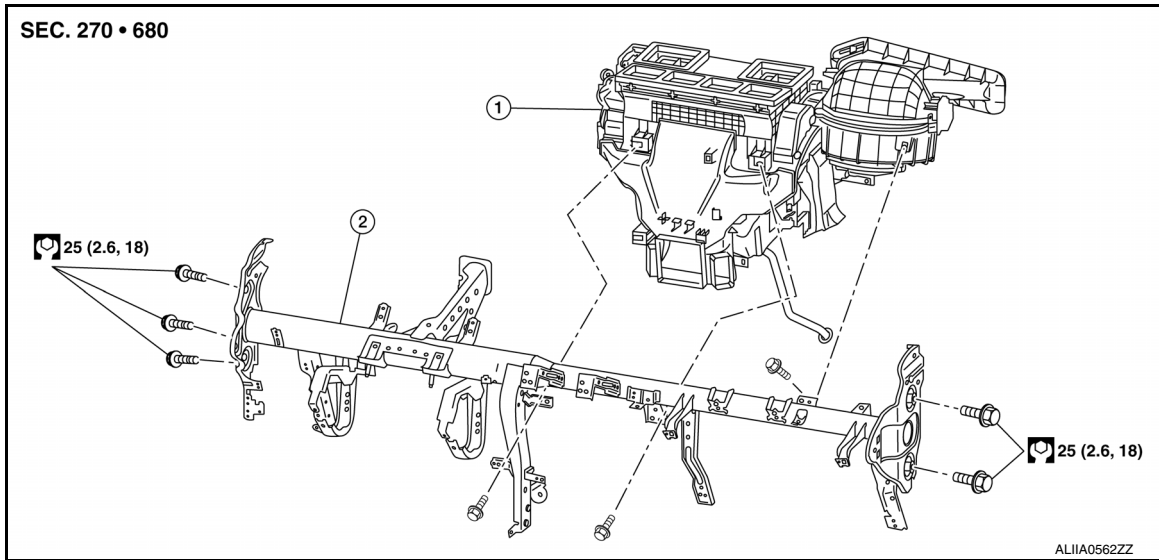

1. Heating and cooling unit assembly    2. Steering member

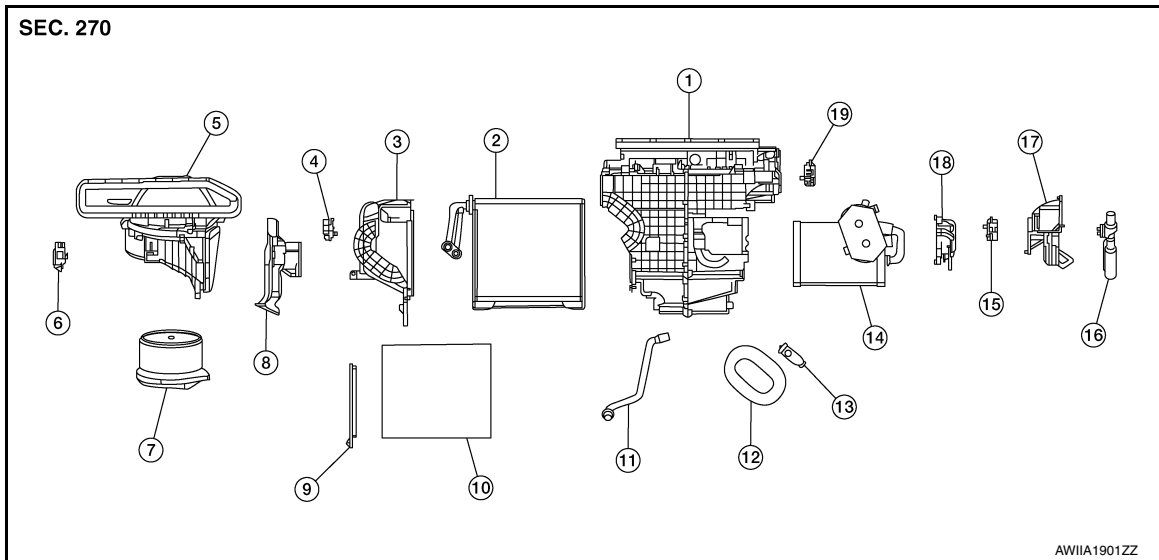

- |  |                                    |                                      |
|--|------------------------------------|--------------------------------------|
| 1. Heating and cooling unit assembly   | 2. Evaporator                      | 3. Heater case side cover            |
| 4. Air mix door motor (passenger side) | 5. Blower unit case                | 6. Intake door motor                 |
| 7. Blower motor                        | 8. Upper floor connecting duct RH  | 9. In-cabin microfilter cover        |
| 10. In-cabin microfilter               | 11. Drain hose                     | 12. Expansion valve grommet          |
| 13. Expansion valve                    | 14. Heater core                    | 15. Air mix door motor (driver side) |
| 16. Aspirator hose                     | 17. Upper floor connecting duct LH | 18. Heater core pipe cover           |
| 19. Mode door motor (front)            |                                    |                                      |

## Removal and Installation

INFOID:000000012876714

### REMOVAL

# HEATING AND COOLING UNIT ASSEMBLY

## < REMOVAL AND INSTALLATION >

### CAUTION:

Before servicing, turn the ignition switch "OFF", disconnect both battery cables and wait at least three minutes.

### NOTE:

When removing components such as hoses, lines/tubes, etc., cap or plug openings to prevent fluid from leaking.

1. Discharge the refrigerant. Refer to [HA-22, "Recycle Refrigerant"](#).
2. Drain the engine coolant. Refer to [CO-10, "Changing Engine Coolant"](#).
3. Remove the instrument panel assembly. Refer to [IP-15, "INSTRUMENT PANEL ASSEMBLY : Removal and Installation"](#).
4. Remove the steering column. Refer to [ST-32, "Removal and Installation"](#).
5. Remove the front floor connecting duct (LH/RH). Refer to [VTL-9, "Exploded View"](#).
6. Disconnect the harness connectors (B) from the super multiple junction (SMJ) block (A).

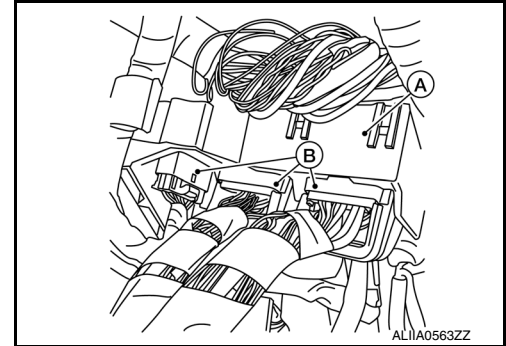

7. Disconnect the high-pressure and low-pressure pipe from the expansion valve.  
**CAUTION:**  
**Cap or wrap the joint of the pipe with suitable material such as vinyl tape to avoid the entry of air.**
8. Disconnect the heater hoses from the heater core.
9. Remove the cowl top extension. Refer to [EXT-34, "Removal and Installation - Cowl Top Cover"](#).
10. Remove the body panel plug (A) then remove the steering member bolt.

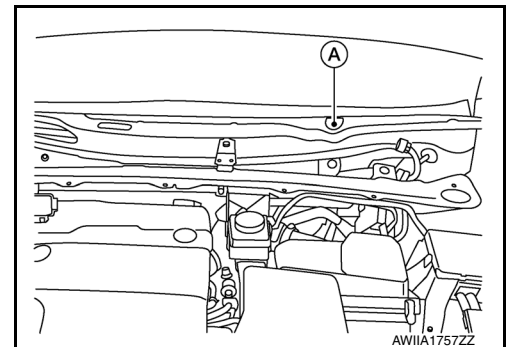

11. Remove the bolts that retain the steering member to the vehicle body.
12. Disconnect the front drain hose from the heating and cooling unit assembly.
13. Disconnect the harness connectors from the heating and cooling unit assembly and steering member.
14. Remove the heating and cooling unit assembly and steering member from the vehicle as an assembly.  
**CAUTION:**  
**Use care not to damage the seats when removing the steering member.**
15. Remove the bolts that retain the heating and cooling unit assembly to the steering member.
16. Separate the heating and cooling unit assembly from the steering member.

## INSTALLATION

Installation is in the reverse order of removal.

# HEATER CORE

< REMOVAL AND INSTALLATION >

## HEATER CORE

### Exploded View

INFOID:000000012876715

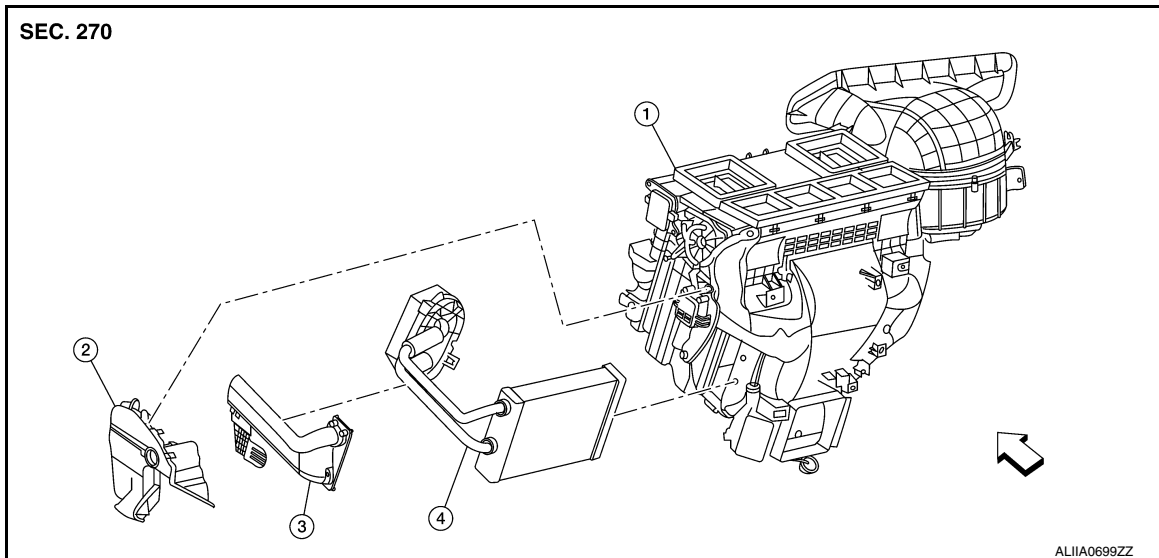

1. Heating and cooling unit assembly

2. Front foot duct (LH)

3. Heater core pipes cover

4. Heater core

⇐ Front

## Removal and Installation

INFOID:000000012876716

### REMOVAL

#### NOTE:

When removing components such as hoses, lines/tubes, etc., cap or plug openings to prevent fluid from spilling.

1. Discharge the refrigerant. Refer to [HA-22, "Recycle Refrigerant"](#).
2. Drain the engine coolant. Refer to [CO-10, "Changing Engine Coolant"](#).
3. Remove the heating and cooling unit assembly. Refer to [HA-41, "Removal and Installation"](#).
4. Remove the front foot duct (LH). Refer to [HA-41, "Exploded View"](#).
5. Remove the heater core pipe cover. Refer to [HA-41, "Exploded View"](#).
6. Remove the heater core.

### INSTALLATION

Installation is in the reverse order of removal.

# EVAPORATOR

< REMOVAL AND INSTALLATION >

## EVAPORATOR

### Removal and Installation

INFOID:000000012876717

#### Heating and Cooling Unit Components

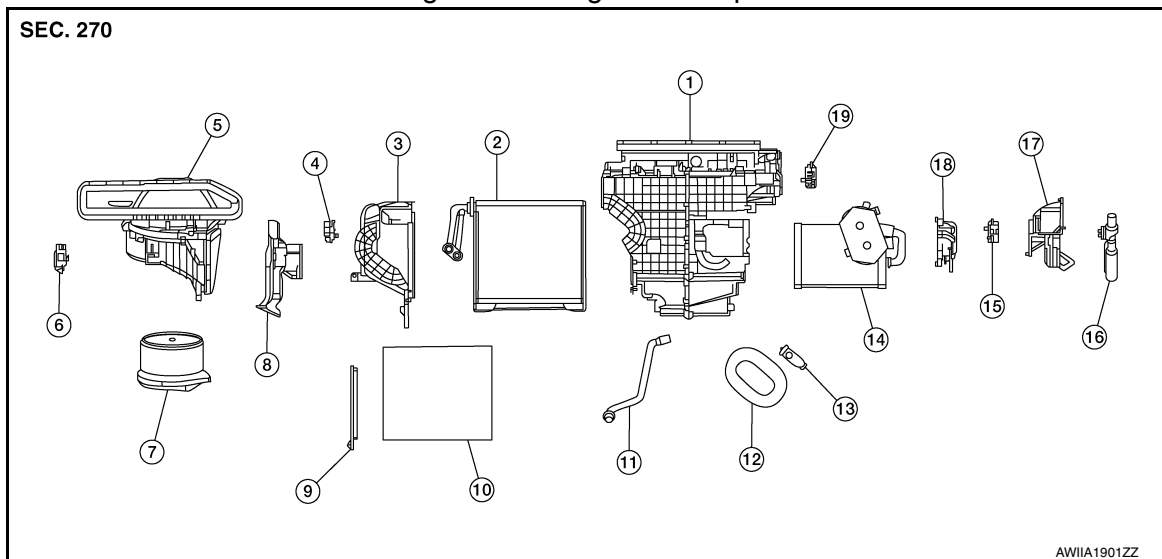

- |  |                                    |                                      |
|--|------------------------------------|--------------------------------------|
| 1. Heating and cooling unit assembly   | 2. Evaporator                      | 3. Heater case side cover            |
| 4. Air mix door motor (passenger side) | 5. Blower unit case                | 6. Intake door motor                 |
| 7. Blower motor                        | 8. Upper floor connecting duct RH  | 9. In-cabin microfilter cover        |
| 10. In-cabin microfilter               | 11. Drain hose                     | 12. Expansion valve grommet          |
| 13. Expansion valve                    | 14. Heater core                    | 15. Air mix door motor (driver side) |
| 16. Aspirator hose                     | 17. Upper floor connecting duct LH | 18. Heater core pipe cover           |
| 19. Mode door motor (front)            |                                    |                                      |

### REMOVAL

1. Discharge the refrigerant. Refer to [HA-22, "Recycle Refrigerant"](#).
2. Remove the heating and cooling unit assembly. Refer to [HA-41, "Exploded View"](#).
3. Remove the blower unit case from the heating and cooling unit assembly.
4. Remove the heater case side cover.
5. Remove the evaporator.

#### **CAUTION:**

**Cap or wrap the joint of the pipe with suitable material such as vinyl tape to avoid the entry of air.**

6. Remove the expansion valve from the evaporator (if necessary).

### INSTALLATION

Installation is in the reverse order of removal.

#### **CAUTION:**

- Do not reuse O-rings.
- Apply A/C oil to new O-rings for installation.
- After charging the refrigerant, check for leaks. Refer to [HA-20, "Leak Test"](#).

# EXPANSION VALVE

< REMOVAL AND INSTALLATION >

## EXPANSION VALVE

### Removal and Installation

INFOID:000000012876718

#### Heating and Cooling Unit Assembly Components

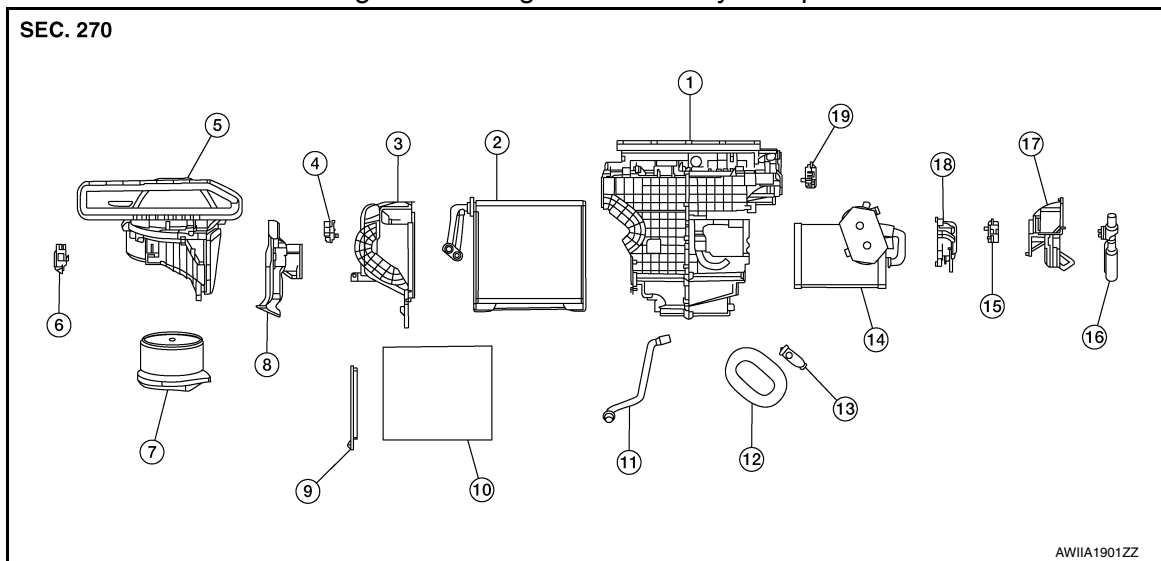

- |  |                                    |                                      |
|--|------------------------------------|--------------------------------------|
| 1. Heating and cooling unit assembly   | 2. Evaporator                      | 3. Heater case side cover            |
| 4. Air mix door motor (passenger side) | 5. Blower unit case                | 6. Intake door motor                 |
| 7. Blower motor                        | 8. Upper floor connecting duct RH  | 9. In-cabin microfilter cover        |
| 10. In-cabin microfilter               | 11. Drain hose                     | 12. Expansion valve grommet          |
| 13. Expansion valve                    | 14. Heater core                    | 15. Air mix door motor (driver side) |
| 16. Aspirator hose                     | 17. Upper floor connecting duct LH | 18. Heater core pipe cover           |
| 19. Mode door motor (front)            |                                    |                                      |

#### REMOVAL

1. Discharge the refrigerant. Refer to [HA-22, "Recycle Refrigerant"](#).
2. Remove the cowl top extension. Refer to [EXT-34, "Removal and Installation - Cowl Top Cover"](#).
3. Disconnect the high-pressure and low-pressure pipe from the expansion valve.
4. Remove the expansion valve bolts then remove the expansion valve.

#### INSTALLATION

Installation is in the reverse order of removal.

#### CAUTION:

- Do not reuse O-rings.
- Apply A/C oil to the O-rings of the expansion valve for installation.
- After charging refrigerant, check for leaks. Refer to [HA-20, "Leak Test"](#).

## SERVICE DATA AND SPECIFICATIONS (SDS)

< SERVICE DATA AND SPECIFICATIONS (SDS)

# SERVICE DATA AND SPECIFICATIONS (SDS)

## SERVICE DATA AND SPECIFICATIONS (SDS)

### Compressor

INFOID:0000000012876719

Type	Variable displacement swash plate	
Displacement		175 cm <sup>3</sup> (10.7 cu in)/rev
Number of cylinders	10	
Cylinder bore diameter × stroke	30.5 x 24 mm (1.2 x 0.9 in)	
Direction of rotation	Clockwise (viewed from clutch)	
Drive belt	Poly V 7 grooves	
Disc to pulley clearance	Standard	0.3 – 0.6 mm (0.012 – 0.024 in)

### Oil

INFOID:0000000012876720

Name	A/C System Oil Type ND-OIL8 (PAG)	
Capacity mℓ (US fl oz, Imp fl oz)	Total in system	100 (3.4, 3.5)
	Compressor (service part) charging amount	Refer to <a href="#">HA-25. "Oil Adjusting Procedure for Compressor Replacement"</a> .

### Refrigerant

INFOID:0000000012876721

Type	HFC-134a (R-134a)
Capacity	0.55 ± 0.03 kg (1.21 ± 0.11 lb)