

SECTION **RF**
ROOF

A
B
C

CONTENTS

PRECAUTION	3	List of ECU Reference	13	F
PRECAUTIONS	3	MOONROOF MOTOR ASSEMBLY	14	G
Precaution for Supplemental Restraint System (SRS) "AIR BAG" and "SEAT BELT PRE-TENSIONER"	3	Reference Value	14	
Procedure without Cowl Top Cover	3	SUNSHADE MOTOR ASSEMBLY	15	H
Precaution for Work	3	Reference Value	15	
PREPARATION	5	WIRING DIAGRAM	16	I
PREPARATION	5	MOONROOF SYSTEM	16	
Special Service Tool	5	Wiring Diagram	16	
Commercial Service Tools	5	BASIC INSPECTION	21	J
SYSTEM DESCRIPTION	6	DIAGNOSIS AND REPAIR WORKFLOW	21	
COMPONENT PARTS	6	Work Flow	21	
Component Parts Location	6	INSPECTION AND ADJUSTMENT	23	RF
Component Description	6	ADDITIONAL SERVICE WHEN REPLACING CONTROL UNIT	23	L
Moonroof Switch	7	ADDITIONAL SERVICE WHEN REPLACING CONTROL UNIT : Special Repair Requirement	23	
Moonroof Motor Assembly	7	DTC/CIRCUIT DIAGNOSIS	24	M
Sunshade Motor Assembly	7	POWER SUPPLY AND GROUND CIRCUIT	24	
SYSTEM	8	BODY CONTROL SYSTEM	24	N
MOONROOF	8	BODY CONTROL SYSTEM : Diagnosis Procedure	24	
MOONROOF : System Diagram	8	MOONROOF MOTOR ASSEMBLY	24	O
MOONROOF : System Description	8	MOONROOF MOTOR ASSEMBLY : Description....	24	
DIAGNOSIS SYSTEM (BCM)	10	MOONROOF MOTOR ASSEMBLY :		P
COMMON ITEM	10	Component Function Check	25	
COMMON ITEM : CONSULT Function (BCM - COMMON ITEM)	10	MOONROOF MOTOR ASSEMBLY :		
RETAINED PWR	11	Diagnosis Procedure	25	
RETAINED PWR : CONSULT Function (BCM - RETAINED PWR)	11	MOONROOF MOTOR ASSEMBLY : Special Repair Requirement	27	
ECU DIAGNOSIS INFORMATION	13	SUNSHADE MOTOR ASSEMBLY	27	
BCM (BODY CONTROL MODULE)	13	SUNSHADE MOTOR ASSEMBLY : Description	27	

SUNSHADE MOTOR ASSEMBLY :		Diagnosis Procedure	38
Component Function Check	28		
SUNSHADE MOTOR ASSEMBLY :		SQUEAK AND RATTLE TROUBLE DIAG- NOSES	39
Diagnosis Procedure	28	Work Flow	39
MOONROOF SWITCH	29	Generic Squeak and Rattle Troubleshooting	40
Description	29	Diagnostic Worksheet	43
Diagnosis Procedure	29	REMOVAL AND INSTALLATION	45
Component Inspection	30	GLASS LID	45
DOOR SWITCH	32	Exploded View	45
Component Function Check	32	Removal and Installation	45
Diagnosis Procedure	32	PANORAMIC ROOF GLASS	47
Component Inspection	33	Exploded View	47
SYMPTOM DIAGNOSIS	34	Removal and Installation	47
MOONROOF DOES NOT OPERATE PROP- ERLY	34	MOONROOF MOTOR ASSEMBLY	49
Diagnosis Procedure	34	Exploded View	49
SUNSHADE SYSTEM DOES NOT OPERATE PROPERLY	35	Removal and Installation	49
Diagnosis Procedure	35	MOONROOF UNIT ASSEMBLY	51
AUTO OPERATION DOES NOT OPERATE	36	Inspection	51
MOONROOF	36	Exploded View	55
MOONROOF : Diagnosis Procedure	36	Removal and Installation	55
SUNSHADE	36	SUNSHADE	57
SUNSHADE : Diagnosis Procedure	36	Removal and Installation	57
ANTI-PINCH FUNCTION DOES NOT OPER- ATE	37	SUNSHADE MOTOR ASSEMBLY	58
MOONROOF	37	Removal and Installation	58
MOONROOF : Diagnosis Procedure	37	WIND DEFLECTOR	59
SUNSHADE	37	Removal and Installation	59
SUNSHADE : Diagnosis Procedure	37	MOONROOF SWITCH	60
RETAINED POWER OPERATION DOES NOT OPERATE PROPERLY	38	Removal and Installation	60
		UNIT DISASSEMBLY AND ASSEMBLY ...	61
		SUNSHADE	61
		Disassembly and Assembly	61

PRECAUTIONS

< PRECAUTION >

PRECAUTION

PRECAUTIONS

Precaution for Supplemental Restraint System (SRS) "AIR BAG" and "SEAT BELT PRE-TENSIONER"

INFOID:000000013472091

The Supplemental Restraint System such as "AIR BAG" and "SEAT BELT PRE-TENSIONER", used along with a front seat belt, helps to reduce the risk or severity of injury to the driver and front passenger for certain types of collision. Information necessary to service the system safely is included in the SR and SB section of this Service Manual.

WARNING:

- To avoid rendering the SRS inoperative, which could increase the risk of personal injury or death in the event of a collision which would result in air bag inflation, it is recommended that all maintenance and repair be performed by an authorized NISSAN/INFINITI dealer.
- Improper repair, including incorrect removal and installation of the SRS, can lead to personal injury caused by unintentional activation of the system. For removal of Spiral Cable and Air Bag Module, see the SR section.
- Do not use electrical test equipment on any circuit related to the SRS unless instructed to in this Service Manual. SRS wiring harnesses can be identified by yellow and/or orange harnesses or harness connectors.

PRECAUTIONS WHEN USING POWER TOOLS (AIR OR ELECTRIC) AND HAMMERS

WARNING:

- When working near the Air Bag Diagnosis Sensor Unit or other Air Bag System sensors with the Ignition ON or engine running, DO NOT use air or electric power tools or strike near the sensor(s) with a hammer. Heavy vibration could activate the sensor(s) and deploy the air bag(s), possibly causing serious injury.
- When using air or electric power tools or hammers, always switch the Ignition OFF, disconnect the battery or batteries, and wait at least three minutes before performing any service.

Procedure without Cowl Top Cover

INFOID:000000012876192

When performing the procedure after removing cowl top cover, cover the lower end of windshield with urethane, etc. to prevent damage to the windshield.

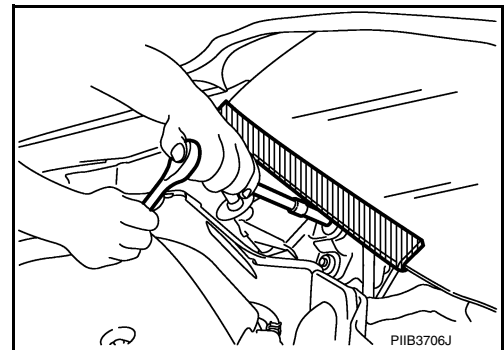

Precaution for Work

INFOID:000000012876193

- When removing or disassembling each component, be careful not to damage or deform it. If a component may be subject to interference, be sure to protect it with a shop cloth.
- When removing (disengaging) components with a screwdriver or similar tool, be sure to wrap the component with a shop cloth or vinyl tape to protect it.
- Protect the removed parts with a shop cloth and prevent them from being dropped.
- Replace a deformed or damaged clip.
- If a part is specified as a non-reusable part, always replace it with a new one.
- Be sure to tighten bolts and nuts securely to the specified torque.
- After installation is complete, be sure to check that each part works properly.
- Follow the steps below to clean components:
 - Water soluble dirt:
 - Dip a soft cloth into lukewarm water, wring the water out of the cloth and wipe the dirty area.
 - Then rub with a soft, dry cloth.
 - Oily dirt:

PRECAUTIONS

< PRECAUTION >

- Dip a soft cloth into lukewarm water with mild detergent (concentration: within 2 to 3%) and wipe the dirty area.
- Then dip a cloth into fresh water, wring the water out of the cloth and wipe the detergent off.
- Then rub with a soft, dry cloth.
- Do not use organic solvent such as thinner, benzene, alcohol or gasoline.
- For genuine leather seats, use a genuine leather seat cleaner.

PREPARATION

< PREPARATION >

PREPARATION

PREPARATION

Special Service Tool

INFOID:0000000012876194

The actual shape of the tools may differ from those illustrated here.

Tool number (TechMate No.) Tool name	Description
— (J-39570) Chassis Ear	Locating the noise
— (J-50397) NISSAN Squeak and Rattle Kit	Repairing the cause of noise
— (J-46534) Trim Tool Set	Removing trim components

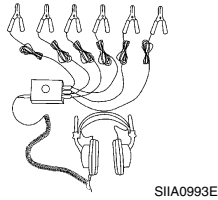

SIA0993E



ALJIA123ZZ

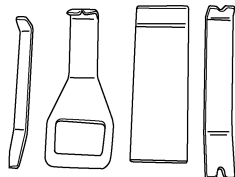

AWJIA0483ZZ

Commercial Service Tools

INFOID:0000000012876195

(TechMate No.) Tool name	Description
(J-39565) Engine Ear	Locating the noise
(—) Power tool	Loosening nuts, screws and bolts

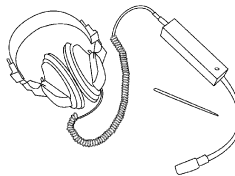

SIA0995E

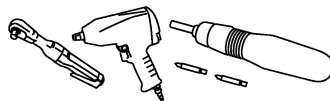

PIIB1407E

COMPONENT PARTS

< SYSTEM DESCRIPTION >

SYSTEM DESCRIPTION

COMPONENT PARTS

Component Parts Location

INFOID:000000012876196

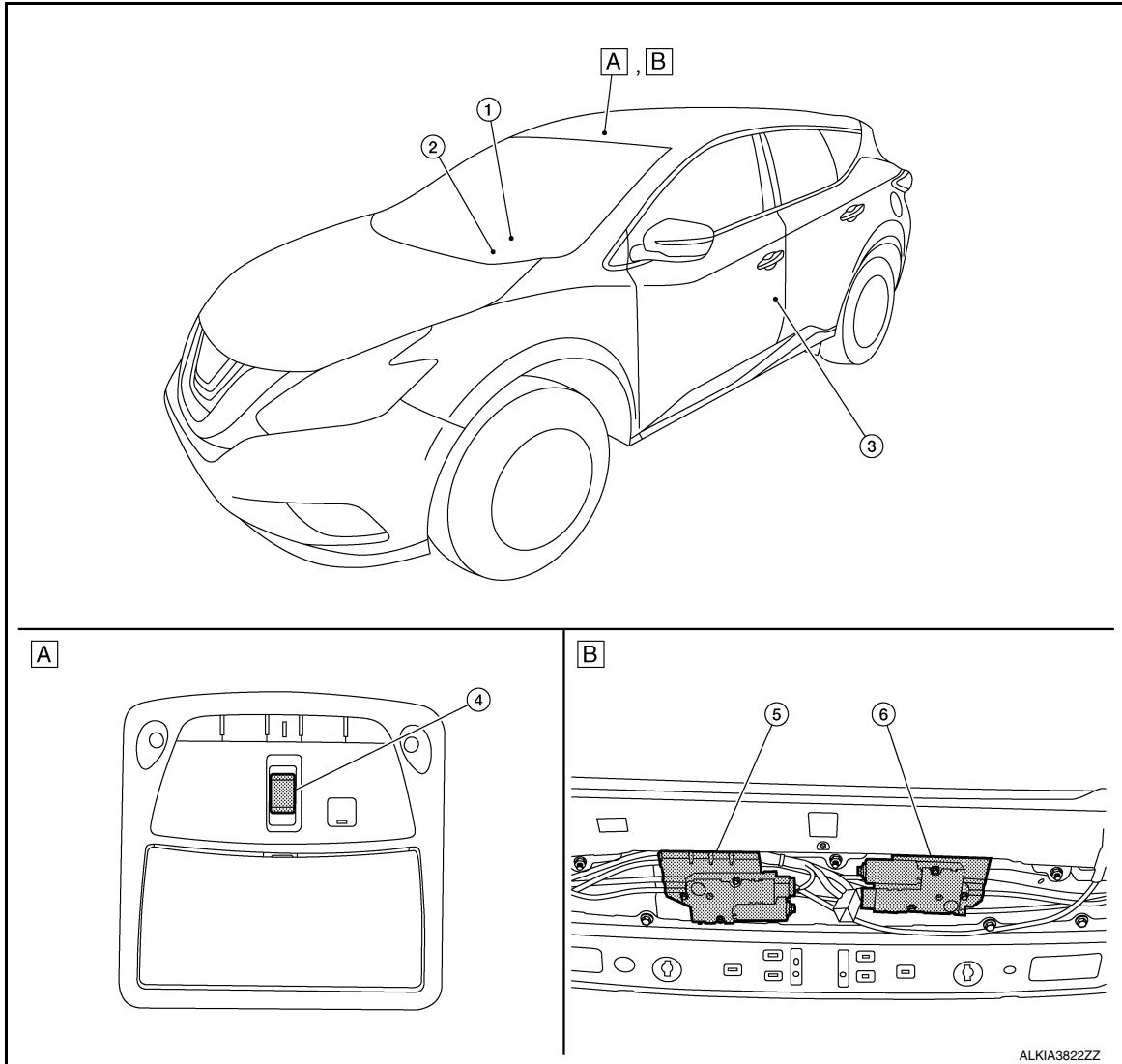

A. Overhead console in headliner

B. View with headliner removed

Component Description

INFOID:000000012876197

No.	Component	Function
1.	BCM	Supplies the power supply to the moonroof & sunshade motor assembly. Refer to BCS-79, "Removal and Installation" for detailed installation information.
2.	Combination meter	Transmits the vehicle speed signal to BCM via CAN communication. Refer to MWI-7, "METER SYSTEM : Combination Meter" for detailed installation information.
3.	Front door switches	Detects door open/close condition and transmits to BCM. Refer to DLK-22, "Front Door Switch" for detailed installation information.
4.	Moonroof switch	Refer to RF-7, "Moonroof Switch" .
5.	Sunshade motor assembly	Refer to RF-7, "Sunshade Motor Assembly" .
6.	Moonroof motor assembly	Refer to RF-7, "Moonroof Motor Assembly" .

COMPONENT PARTS

< SYSTEM DESCRIPTION >

Moonroof Switch

INFOID:000000012876198

Transmits tilt up/slide close and tilt down/slide open signal to moonroof motor and sunshade motor assemblies.

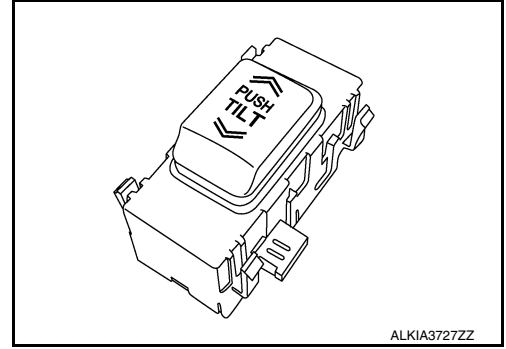

Moonroof Motor Assembly

INFOID:000000012876199

Moonroof motor and CPU are integrated in moonroof motor assembly. Moonroof motor assembly operates moonroof to tilt up/down or slide open/close by moonroof switch operation.

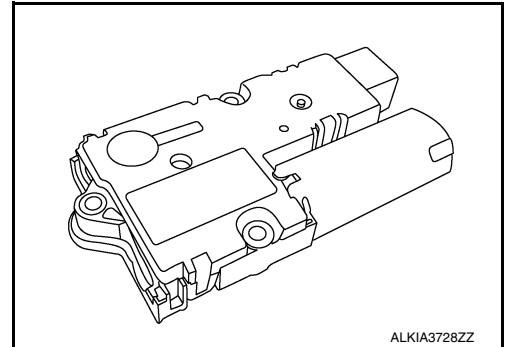

Sunshade Motor Assembly

INFOID:000000012876200

Activated with a signal from the moonroof switch.

A
B
C
D
E
F
G
H
I
J
L
M
N
O
P

RF

SYSTEM

< SYSTEM DESCRIPTION >

SYSTEM MOONROOF

MOONROOF : System Diagram

INFOID:000000012876201

MOONROOF & SUNSHADE

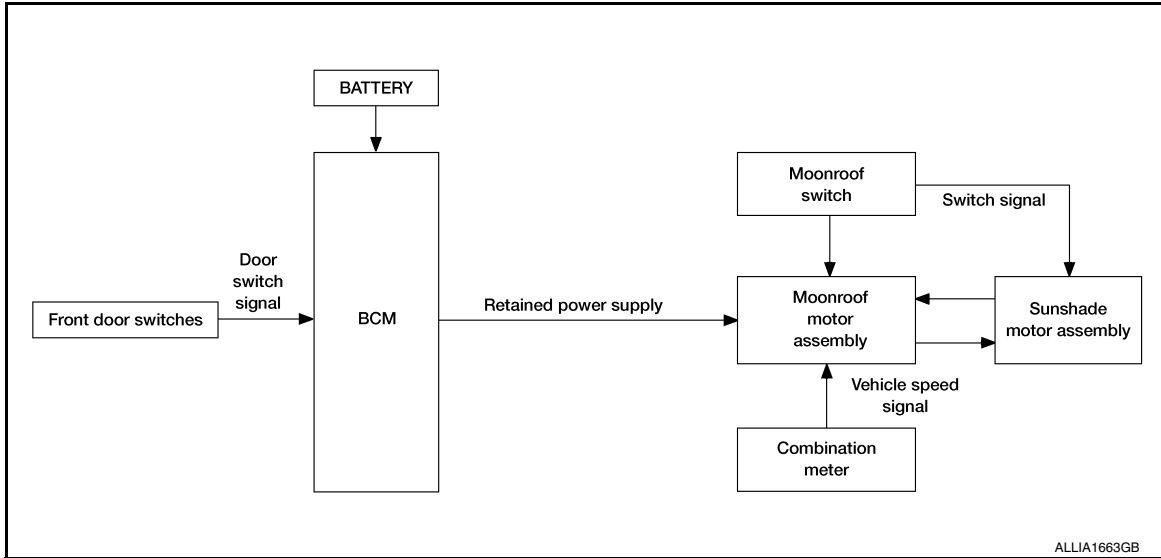

MOONROOF : System Description

INFOID:000000012876202

MOONROOF SYSTEM INPUT/OUTPUT SIGNAL CHART

Item	Input signal to moonroof motor assembly	Moonroof motor function	Actuator
Moonroof switch	Moonroof signal (tilt up/down or slide open/close)	Receives signal and moves the moonroof and sunshade assembly to the correct position.	Moonroof motor and/or Sunshade motor
	Sunshade signal (slide open/close)		
Combination meter	Vehicle speed signal	Receives speed signal and determines the amount of torque the motor requires.	
BCM	RAP signal	Retained power after the key is turned off and the front doors remain closed.	

MOONROOF AND SUNSHADE OPERATION

- The moonroof motor assembly and sunshade motor assembly operates with the power supply that is output from the BCM while the ignition switch is ON or retained power is operating.
- Tilt up/down & slide open/close signals from the moonroof switch enable the moonroof motor and sunshade motor to move.
- Moonroof motor assembly receives a vehicle speed signal from the combination meter and controls the moonroof motor torque of tilt down at the time of high speed operation.

AUTO OPERATION

Moonroof and Sunshade AUTO feature makes it possible to slide open and slide closed the moonroof and sunshade without holding the moonroof switch in the slide open/close position.

RETAINED POWER OPERATION

- Retained power operation is an additional power supply function that enables the moonroof and sunshade system to operate for 45 seconds after the ignition switch is turned off and the front doors remain closed.

Retained power function cancel conditions:

SYSTEM

< SYSTEM DESCRIPTION >

- Door CLOSE (door switch OFF)→OPEN (door switch ON).
- When ignition switch is ON again.
- When timer time passes (45 seconds).

A

ANTI-PINCH FUNCTION

The moonroof and sunshade motor's built in CPU monitors the moonroof motor and sunshade motor operation and position.

B

If a restriction is detected during the slide closed operation the moonroof/sunshade motor will move the glass/sunshade into the open positions.

C

D

E

F

G

H

I

J

RF

L

M

N

O

P

DIAGNOSIS SYSTEM (BCM)

< SYSTEM DESCRIPTION >

DIAGNOSIS SYSTEM (BCM)

COMMON ITEM

COMMON ITEM : CONSULT Function (BCM - COMMON ITEM)

INFOID:000000013387430

APPLICATION ITEM

CONSULT performs the following functions via CAN communication with BCM.

Direct Diagnostic Mode	Description
ECU Identification	The BCM part number is displayed.
Self Diagnostic Result	The BCM self diagnostic results are displayed.
Data Monitor	The BCM input/output data is displayed in real time.
Active Test	The BCM activates outputs to test components.
Work support	The settings for BCM functions can be changed.
Configuration	<ul style="list-style-type: none"> The vehicle specification can be read and saved. The vehicle specification can be written when replacing BCM.
CAN Diag Support Mntr	The result of transmit/receive diagnosis of CAN communication is displayed.

SYSTEM APPLICATION

BCM can perform the following functions:

System	Sub System	Direct Diagnostic Mode						
		ECU Identification	Self Diagnostic Result	Data Monitor	Active Test	Work support	Configuration	CAN Diag Support Mntr
Door lock	DOOR LOCK		×	×	×	×		
Rear window defogger	REAR DEFOGGER			×	×	×		
Warning chime	BUZZER			×	×			
Interior room lamp timer	INT LAMP			×	×	×		
Exterior lamp	HEADLAMP			×	×	×		
Wiper and washer	WIPER			×	×	×		
Turn signal and hazard warning lamps	FLASHER			×	×	×		
Air conditioner	AIR CONDITIONER			×				
Intelligent Key system	INTELLIGENT KEY		×	×	×	×		
Combination switch	COMB SW			×				
BCM	BCM	×	×			×	×	×
Immobilizer	IMMU		×	×	×			
Interior room lamp battery saver	BATTERY SAVER			×	×			
Back door open	TRUNK			×				
Vehicle security system	THEFT ALM			×	×	×		
RAP system	RETAINED PWR			×				
Signal buffer system	SIGNAL BUFFER			×	×			
TPMS	AIR PRESSURE MONITOR		×	×	×			

FREEZE FRAME DATA (FFD)

DIAGNOSIS SYSTEM (BCM)

< SYSTEM DESCRIPTION >

The BCM records the following vehicle condition at the time a particular DTC is detected, and displays it on CONSULT.

CONSULT screen item	Indication/Unit	Description	
Vehicle Speed	km/h	Vehicle speed at the moment a particular DTC is detected	
Odo/Trip Meter	km	Total mileage (Odometer value) at the moment a particular DTC is detected	
Vehicle Condition	SLEEP>LOCK	Power position status at the moment a particular DTC is detected*	While turning BCM status from low power consumption mode to normal mode (Power supply position is "LOCK"*).
	SLEEP>OFF		While turning BCM status from low power consumption mode to normal mode (Power supply position is "OFF".)
	LOCK>ACC		While turning power supply position from "LOCK" *to "ACC"
	ACC>ON		While turning power supply position from "ACC" to "IGN"
	RUN>ACC		While turning power supply position from "RUN" to "ACC" (Vehicle is stopped and selector lever is in P position.)
	CRANK>RUN		While turning power supply position from "CRANKING" to "RUN" (From cranking up the engine to run it)
	RUN>URGENT		While turning power supply position from "RUN" to "ACC" (Emergency stop operation)
	ACC>OFF		While turning power supply position from "ACC" to "OFF"
	OFF>LOCK		While turning power supply position from "OFF" to "LOCK"*
	OFF>ACC		While turning power supply position from "OFF" to "ACC"
	ON>CRANK		While turning power supply position from "IGN" to "CRANKING"
	OFF>SLEEP		While turning BCM status from normal mode (Power supply position is "OFF".) to low power consumption mode
	LOCK>SLEEP		While turning BCM status from normal mode (Power supply position is "LOCK"*.) to low power consumption mode
	LOCK		Power supply position is "LOCK" (Ignition switch OFF)*
	OFF		Power supply position is "OFF" (Ignition switch OFF)
	ACC		Power supply position is "ACC" (Ignition switch ACC)
	ON		Power supply position is "IGN" (Ignition switch ON with engine stopped)
ENGINE RUN	Power supply position is "RUN" (Ignition switch ON with engine running)		
CRANKING	Power supply position is "CRANKING" (At engine cranking)		
IGN Counter	0 - 39	The number of times that ignition switch is turned ON after DTC is detected <ul style="list-style-type: none"> • The number is 0 when a malfunction is detected now. • The number increases like 1 → 2 → 3...38 → 39 after returning to the normal condition whenever ignition is switched OFF → ON. • The number is fixed to 39 until the self-diagnosis results are erased if it is over 39. 	

NOTE:

*: Power supply position shifts to "LOCK" from "OFF", when ignition switch is in the OFF position, selector lever is in the P position, and any of the following conditions are met:

- Closing door
- Opening door
- Door is locked using door request switch
- Door is locked using Intelligent Key

The power supply position shifts to "ACC" when the push-button ignition switch (push switch) is pushed at "LOCK".

RETAINED PWR

RETAINED PWR : CONSULT Function (BCM - RETAINED PWR)

INFOID:0000000013387431

DATA MONITOR

DIAGNOSIS SYSTEM (BCM)

< SYSTEM DESCRIPTION >

Monitor Item [Unit]	Description
DOOR SW-DR [On/Off]	Indicates condition of front door switch LH.
DOOR SW-AS [On/Off]	Indicates condition of front door switch RH.

BCM (BODY CONTROL MODULE)

< ECU DIAGNOSIS INFORMATION >

ECU DIAGNOSIS INFORMATION

BCM (BODY CONTROL MODULE)

List of ECU Reference

INFOID:0000000012876205

ECU	Reference
BCM	BCS-30, "Reference Value"
	BCS-50, "Fail Safe"
	BCS-51, "DTC Inspection Priority Chart"
	BCS-52, "DTC Index"

A
B
C
D
E
F
G
H
I
J
RF
L
M
N
O
P

MOONROOF MOTOR ASSEMBLY

< ECU DIAGNOSIS INFORMATION >

MOONROOF MOTOR ASSEMBLY

Reference Value

INFOID:000000012876206

TERMINAL LAYOUT

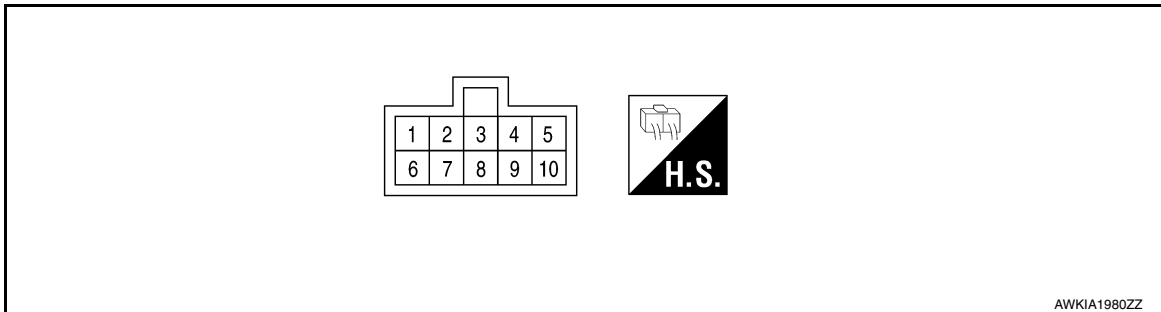

PHYSICAL VALUES

Terminal No. (Wire color)		Description		Condition	Voltage (Approx.)
+	-	Signal name	Input/ Output		
1 (L/W)	Ground	Battery power supply	Input	—	Battery voltage
2 (SB)	Ground	Double detent switch signal	Output	Moonroof switch in following position: • OPEN • CLOSE	0V
3 (G)	Ground	Moonroof push switch signal	Input	—	Battery voltage
4 (Y)	Ground	Vehicle speed signal (2-pulse)	Input	Speedometer operated [When vehicle speed is approx.40km/ h (25MPH)]	
5 (B)	Ground	Ground	—	—	0V
6 (R/Y)	Ground	Ignition power supply	Input	Supplies power to moonroof motor assembly when ignition is in ON position.	Battery voltage
7 (P)	Ground	Open switch signal	Input	Moonroof switch in following position: • OPEN	0V
8 (L/B)	Ground	Close switch signal	Input	Moonroof switch in following position: • CLOSE	0V
9 (W)	Ground	Motor communication	Input/ Output	Provides communication link between sunshade motor assembly and moonroof motor assembly.	0V

SUNSHADE MOTOR ASSEMBLY

< ECU DIAGNOSIS INFORMATION >

SUNSHADE MOTOR ASSEMBLY

Reference Value

INFOID:000000012876207

TERMINAL LAYOUT

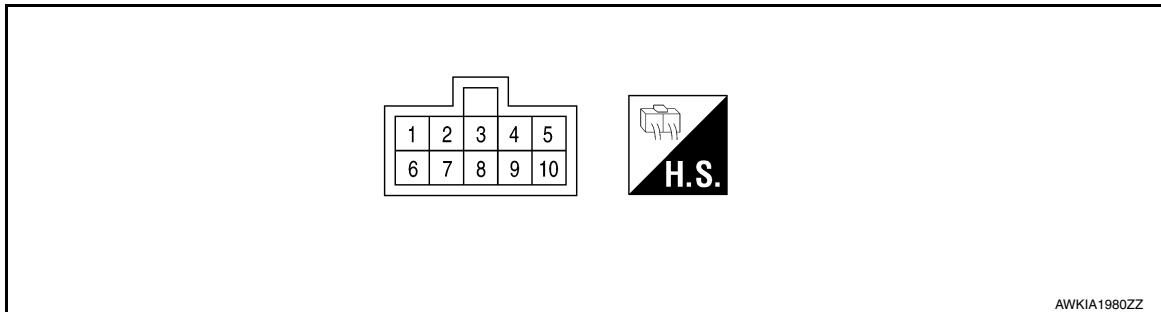

PHYSICAL VALUES

Terminal No. (Wire color)		Description		Condition	Voltage (Approx.)
+	-	Signal name	Input/ Output		
1 (P)	Ground	Battery	Input	Supplies power to sunshade motor.	Battery voltage
5 (GR)	Ground	Ground	—	—	0V
9 (W)	Ground	Serial communication	Input/ Output	Provides communication link between sunshade motor assembly and moonroof motor assembly.	0V

A
B
C
D
E
F
G
H
I
J
RF
L
M
N
O
P

MOONROOF SYSTEM

< WIRING DIAGRAM >

WIRING DIAGRAM

MOONROOF SYSTEM

Wiring Diagram

INFOID:000000012876208

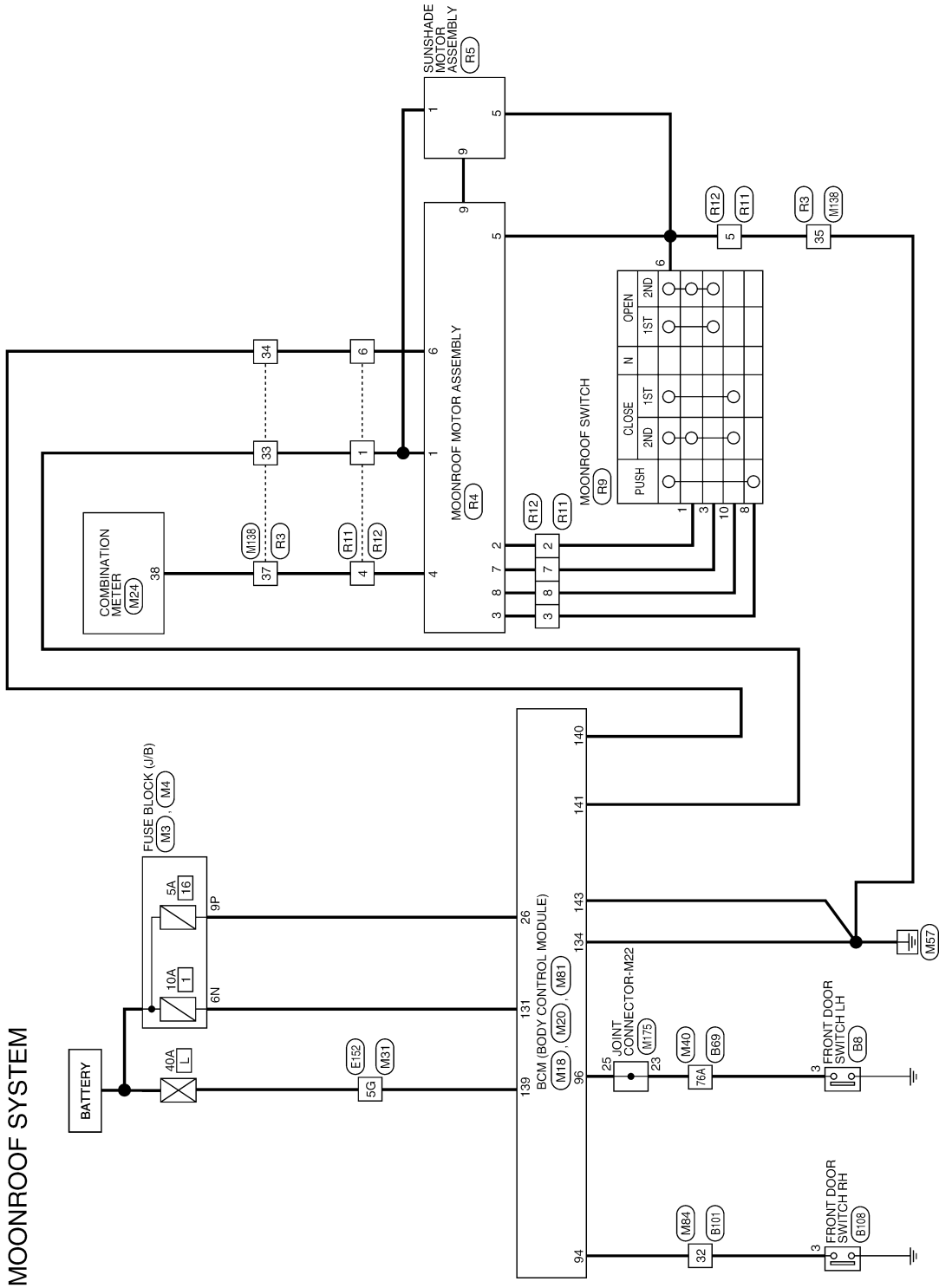

AAKWA1390GB

MOONROOF SYSTEM

< WIRING DIAGRAM >

MOONROOF SYSTEM CONNECTORS

Connector No.	M3
Connector Name	FUSE BLOCK (J/B)
Connector Type	CS06FW-M2
Connector Color	WHITE

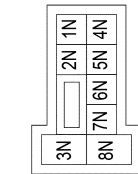

Terminal No.	6N	Color of Wire	W	Signal Name	-
--------------	----	---------------	---	-------------	---

Connector No.	M4
Connector Name	FUSE BLOCK (J/B)
Connector Type	NS16FW-CS
Connector Color	WHITE



Terminal No.	9P	Color of Wire	L	Signal Name	-
--------------	----	---------------	---	-------------	---

Connector No.	M18
Connector Name	BCM (BODY CONTROL MODULE)
Connector Type	TH40FG-NH
Connector Color	GREEN

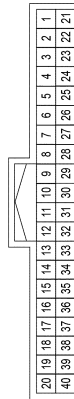

Terminal No.	26	Color of Wire	L	Signal Name	SHORTING INPUT
--------------	----	---------------	---	-------------	----------------

Connector No.	M20
Connector Name	BCM (BODY CONTROL MODULE)
Connector Type	TH24FGY-NH
Connector Color	GRAY

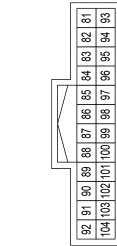

Terminal No.	94	Color of Wire	G	Signal Name	AS DOOR SW
Terminal No.	96	Color of Wire	BG	Signal Name	DR DOOR SW

Connector No.	M24
Connector Name	COMBINATION METER
Connector Type	TH40FW-NH
Connector Color	WHITE

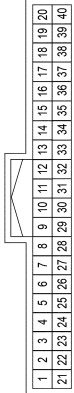

Terminal No.	38	Color of Wire	BR	Signal Name	SPEED 8PR
--------------	----	---------------	----	-------------	-----------

Connector No.	M31
Connector Name	WIRE TO WIRE
Connector Type	TH80FW-CS16-TM4
Connector Color	WHITE

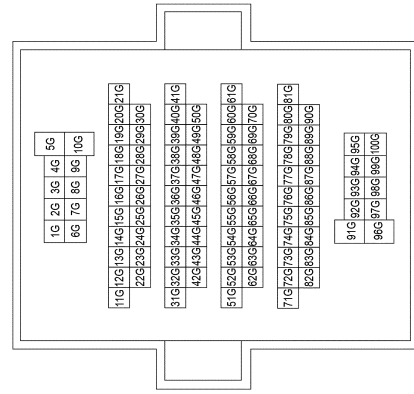

Terminal No.	5G	Color of Wire	L	Signal Name	-
--------------	----	---------------	---	-------------	---

A
B
C
D
E
F
G
H
I
J
L
M
N
O
P

RF

MOONROOF SYSTEM

< WIRING DIAGRAM >

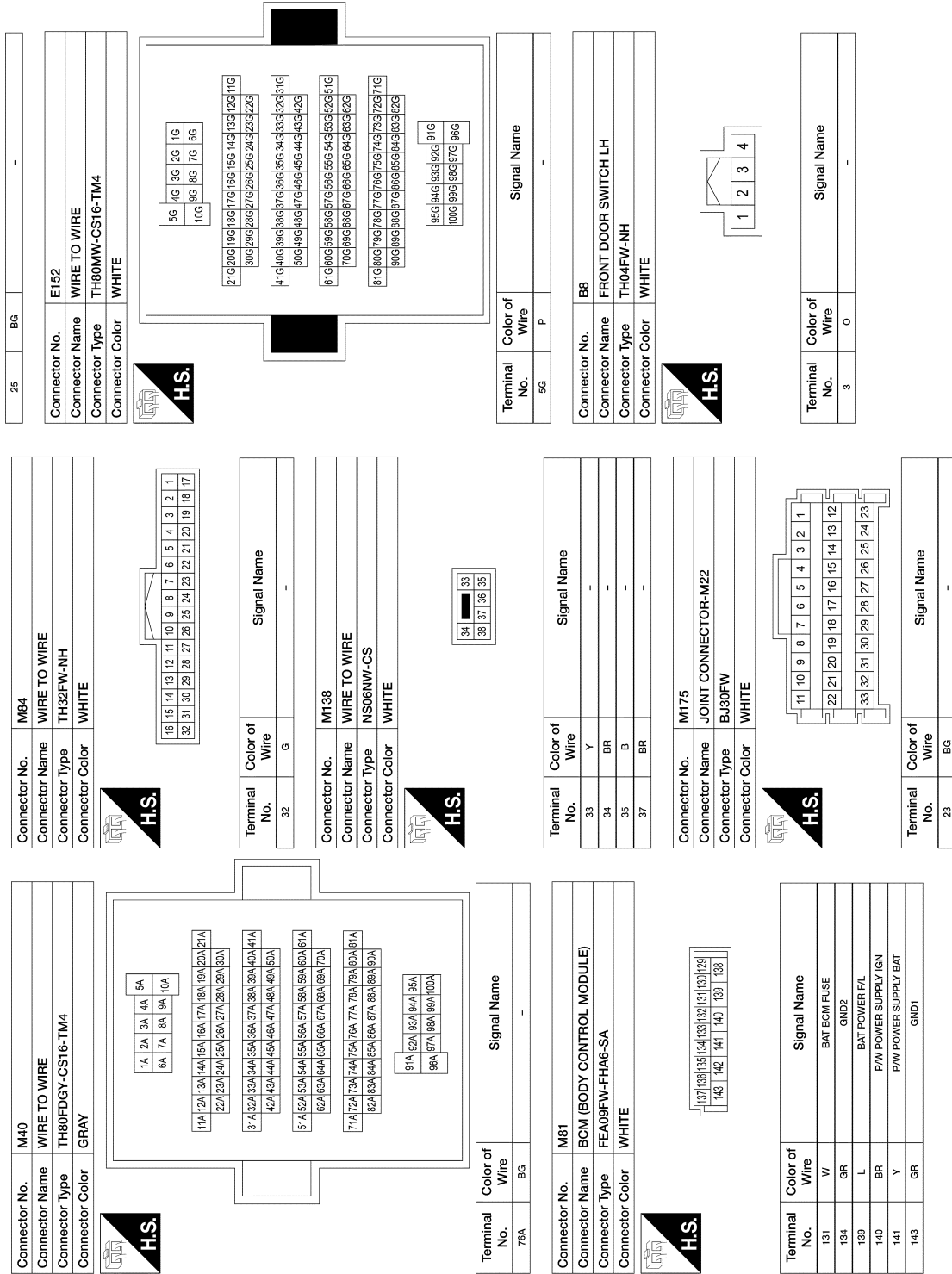

MOONROOF SYSTEM

< WIRING DIAGRAM >

3	G	PUSH
4	Y	VEHICLE SPEED
5	B	GND1
6	R/Y	IGN
7	P	OPEN SW
8	L/B	CLOSE SW
9	W	MOTOR COMMUNICATION

Connector No.	R5
Connector Name	SUNSHADE MOTOR ASSEMBLY
Connector Type	7382-7757-30
Connector Color	GRAY

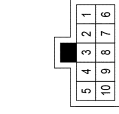

Terminal No.	Color of Wire	Signal Name
1	P	-
5	GR	-
9	W	-

Connector No.	R9
Connector Name	MOONROOF SWITCH
Connector Type	TH12FW-NH
Connector Color	WHITE

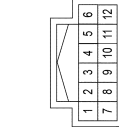

Terminal No.	Color of Wire	Signal Name
1	SB	-
3	P	-
6	B	-
8	G	-
10	L/B	-

Connector No.	B108
Connector Name	FRONT DOOR SWITCH RH
Connector Type	TH04FW-NH
Connector Color	WHITE

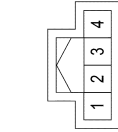

Terminal No.	Color of Wire	Signal Name
3	V	-

Connector No.	R3
Connector Name	WIRE TO WIRE
Connector Type	NS06FW-CS
Connector Color	WHITE

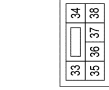

Terminal No.	Color of Wire	Signal Name
33	L/W	-
34	R/Y	-
35	B	-
37	Y	-

Connector No.	R4
Connector Name	MOONROOF MOTOR ASSEMBLY
Connector Type	7382-7757-30
Connector Color	GRAY

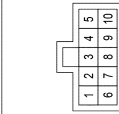

Terminal No.	Color of Wire	Signal Name
1	L/W	BATT1
2	SB	DOUBLE DETENT SW

Connector No.	B69
Connector Name	WIRE TO WIRE
Connector Type	TH80MDGY-CS16-TM4
Connector Color	GRAY

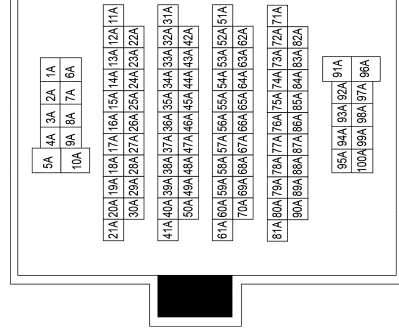

Terminal No.	Color of Wire	Signal Name
76A	O	-

Connector No.	B101
Connector Name	WIRE TO WIRE
Connector Type	TH32MW-NH
Connector Color	WHITE

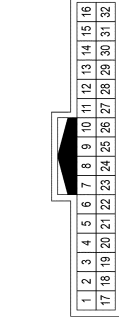

Terminal No.	Color of Wire	Signal Name
32	V	-

AAKIA3342GB

A
B
C
D
E
F
G
H
I
J
K
L
M
N
O
P

RF

MOONROOF SYSTEM

< WIRING DIAGRAM >

Connector No.	R11
Connector Name	WIPE TO WIRE
Connector Type	YEA10FGY-LC
Connector Color	GRAY

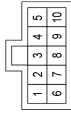

Terminal No.	Color of Wire	Signal Name
1	L/W	-
2	SB	-
3	G	-
4	Y	-
5	B	-
6	R/Y	-
7	P	-
8	L/B	-

Connector No.	R12
Connector Name	WIPE TO WIRE
Connector Type	YEA10MGY-LC
Connector Color	GRAY

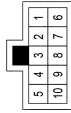

Terminal No.	Color of Wire	Signal Name
1	L/W	-
2	SB	-
3	G	-
4	Y	-
5	B	-
6	R/Y	-
7	P	-
8	L/B	-

AAKIA3343GB

DIAGNOSIS AND REPAIR WORKFLOW

< BASIC INSPECTION >

BASIC INSPECTION

DIAGNOSIS AND REPAIR WORKFLOW

Work Flow

INFOID:0000000012876209

OVERALL SEQUENCE

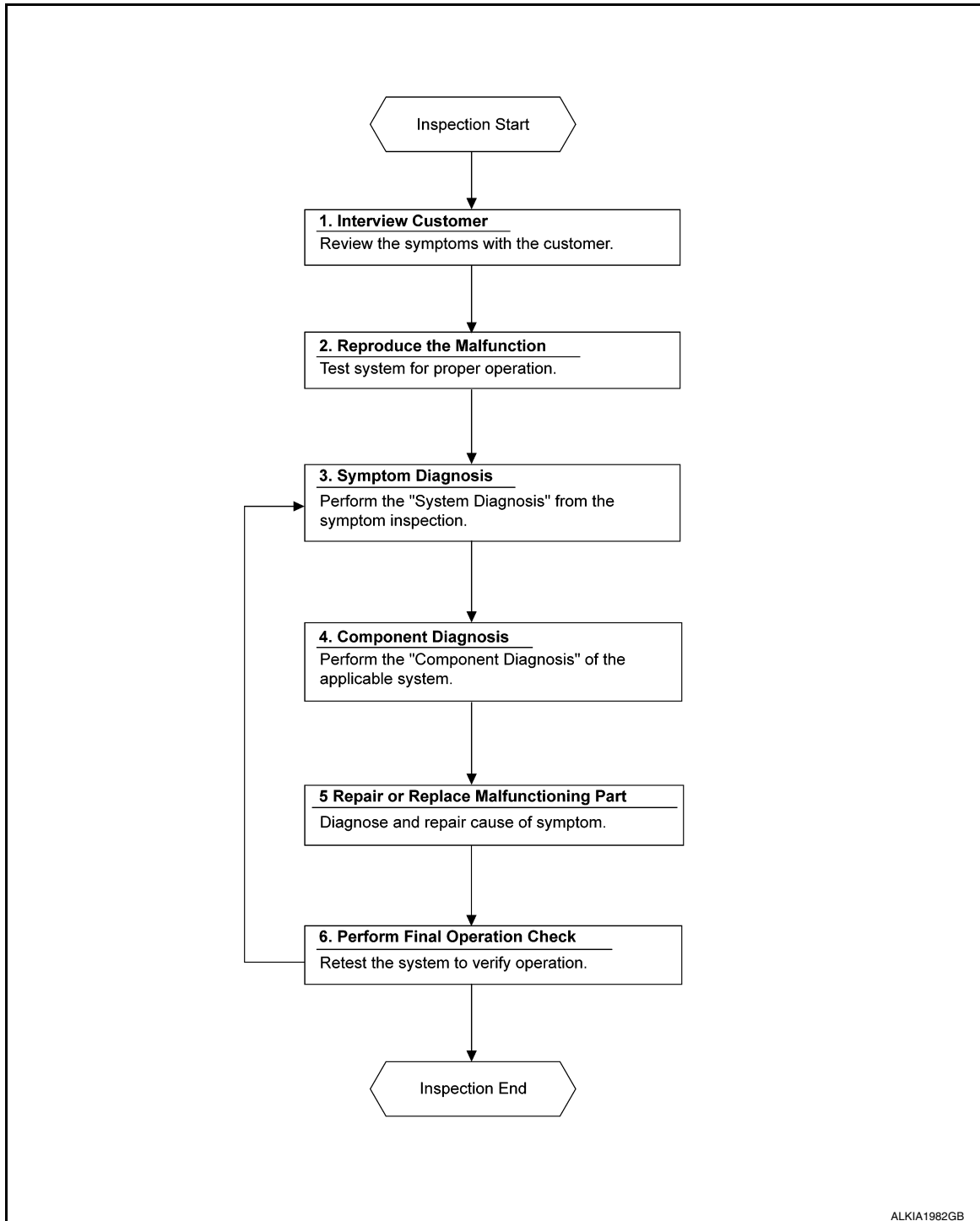

DETAILED FLOW

1. INTERVIEW CUSTOMER

Interview the customer to obtain as much information as possible about the conditions and environment under which the malfunction occurred.

A
B
C
D
E
F
G
H
I
J
RF
L
M
N
O
P

DIAGNOSIS AND REPAIR WORKFLOW

< BASIC INSPECTION >

>> GO TO 2.

2. REPRODUCE THE MALFUNCTION

Reproduce the malfunction on the vehicle that the customer describes.
Inspect the relation of the symptoms and the condition when the symptoms occur.

>> GO TO 3.

3. SYMPTOM DIAGNOSIS

Use Symptom diagnosis from the symptom inspection result in step 2 and then identify where to start performing the diagnosis based on possible causes and symptoms.

>> GO TO 4.

4. COMPONENT DIAGNOSIS

Perform the diagnosis with Component diagnosis of the applicable system.

>> GO TO 5.

5. REPAIR OR REPLACE THE MALFUNCTIONING PART

Repair or replace the specified malfunctioning parts.

>> GO TO 6.

6. PERFORM FINAL OPERATIONAL CHECK

Check that malfunctions are not reproduced when obtaining the malfunction information from the customer, referring to the symptom inspection result in step 2.

Are the malfunctions corrected?

YES >> Inspection End.

NO >> GO TO 3.

INSPECTION AND ADJUSTMENT

< BASIC INSPECTION >

INSPECTION AND ADJUSTMENT

ADDITIONAL SERVICE WHEN REPLACING CONTROL UNIT

ADDITIONAL SERVICE WHEN REPLACING CONTROL UNIT : Special Repair Requirement

INFOID:000000012876210

INITIALIZATION PROCEDURE

Moonroof/Sunshade

If the moonroof does not open or close automatically, use the following procedure to return moonroof operation to normal.

1. Place the ignition switch in the ON position.
2. Fully close the moonroof glass and sunshade by pressing the moonroof switch in the close position.
3. Press and hold the close switch until the moonroof glass and sunshade operate through several small movements (4 - 15 seconds).
4. Once the moonroof has been motionless for 5 seconds, release the close switch .
5. Verify moonroof and sunshade operation by tilting the moonroof glass to vent, opening and closing the moonroof and sunshade.

NOTE:

Repeat this procedure if the moonroof and/or sunshade still do not operate normally.

ANTI-PINCH FUNCTION

Moonroof

1. Fully open the moonroof to the full open position.
2. Place a piece of wood at the fully closed position.
3. Close the moonroof completely with auto-slide close function.
4. Moonroof should make contact and then tilt up or travel in reverse for 200mm (7.87 in.).

Sunshade

1. Open the sunshade to the full open position.
2. Place a piece of wood at the fully closed position.
3. Close the sunshade completely with auto-slide close function.
4. Sunshade should make contact and then travel in reverse for 100mm (3.94 in.).

CAUTION:

- **Do not test the anti-pinch function with your hands or other body parts because they may be pinched.**
- **Depending on the environment and driving conditions, if a similar impact or load is applied to the moonroof it may lower.**
- **Test the auto-slide operation before inspection when the initialization procedure is performed.**
- **Perform the initialization procedure when the auto-slide operation or anti-pinch function does not operate normally.**

POWER SUPPLY AND GROUND CIRCUIT

< DTC/CIRCUIT DIAGNOSIS >

DTC/CIRCUIT DIAGNOSIS

POWER SUPPLY AND GROUND CIRCUIT BODY CONTROL SYSTEM

BODY CONTROL SYSTEM : Diagnosis Procedure

INFOID:0000000013387432

Regarding Wiring Diagram information, refer to [BCS-55, "Wiring Diagram"](#).

1. CHECK FUSE AND FUSIBLE LINK

Check that the following fuse and fusible link are not blown.

Signal name	Fuse and fusible link No.
Fusible link battery power	L (40A)
BCM battery fuse	1 (10A)

Is the fuse or fusible link blown?

- YES >> Replace the blown fuse or fusible link after repairing the affected circuit.
NO >> GO TO 2.

2. CHECK POWER SUPPLY CIRCUIT

1. Disconnect BCM connector M81.
2. Check voltage between BCM connector M81 terminals 131, 139 and ground.

BCM		Ground	Voltage (Approx.)
Connector	Terminal		
M81	131	—	Battery voltage
	139		

Is the inspection result normal?

- YES >> GO TO 3.
NO >> Repair or replace harness or connectors.

3. CHECK GROUND CIRCUIT

Check continuity between BCM connector M81 terminals 134, 143 and ground.

BCM		Ground	Continuity
Connector	Terminal		
M81	134	—	Yes
	143		

Is the inspection result normal?

- YES >> Inspection End.
NO >> Repair or replace harness or connectors.

MOONROOF MOTOR ASSEMBLY

MOONROOF MOTOR ASSEMBLY : Description

INFOID:0000000012876212

- BCM supplies the moonroof motor assembly with power.
- CPU is integrated in moonroof motor assembly.
- Tilts up/down & slides open/close by moonroof switch operation.
- In order to close the moonroof during high speed driving, the Combination meter will send a speed signal to the moonroof CPU to adjust the torque of the motor during the tilt-down operation.

POWER SUPPLY AND GROUND CIRCUIT

< DTC/CIRCUIT DIAGNOSIS >

MOONROOF MOTOR ASSEMBLY : Component Function Check

INFOID:000000012876213

1. CHECK MOONROOF MOTOR FUNCTION

Does the tilt up/down & slide open/close functions operate normally with moonroof switch?

Is the inspection result normal?

YES >> Moonroof motor assembly is OK.

NO >> Refer to [RF-25. "MOONROOF MOTOR ASSEMBLY : Diagnosis Procedure"](#).

MOONROOF MOTOR ASSEMBLY : Diagnosis Procedure

INFOID:000000012876214

Regarding Wiring Diagram information, refer to [RF-16. "Wiring Diagram"](#).

MOONROOF MOTOR ASSEMBLY

1. CHECK POWER SUPPLY CIRCUIT

1. Turn ignition switch OFF.
2. Disconnect the moonroof motor assembly connector R4.
3. Turn ignition switch ON.
4. Check voltage between moonroof motor assembly connector R4 terminals 1 and 6 and ground.

Terminal		Voltage (Approx.)
(+)	(-)	
Moonroof motor assembly	Terminal	Battery voltage
R4	1	
	6	

Is the inspection result normal?

YES >> GO TO 2.

NO >> GO TO 3.

2. CHECK GROUND CIRCUIT

1. Turn ignition switch OFF.
2. Check continuity between moonroof motor assembly connector R4 terminal 5 and ground.

Moonroof motor assembly	Terminal	(-)	Continuity
R4	5	Ground	Yes

Is the inspection result normal?

YES >> GO TO 3.

NO >> Repair or replace harness.

3. CHECK MOONROOF SWITCH INPUT SIGNAL

1. Connect moonroof motor assembly.
2. Turn ignition switch ON.
3. Check voltage between the moonroof motor assembly connector R4 terminals 7 and 8 and ground.

Moonroof motor as- sembly	Terminals		Condition	Voltage (Approx.)
	(+)	(-)		

A
B
C
D
E
F
G
H
I
J
L
M
N
O
P

RF

POWER SUPPLY AND GROUND CIRCUIT

< DTC/CIRCUIT DIAGNOSIS >

R4	7	Ground	Moonroof switch is operated TILT DOWN or SLIDE OPEN	0V
			Other than above	Battery voltage
	8		Moonroof switch is operated TILT UP or SLIDE CLOSE	0V
			Other than above	Battery voltage

Is the inspection result normal?

YES >> GO TO 6.

NO >> GO TO 4.

4. CHECK MOONROOF SWITCH CIRCUIT

1. Turn ignition switch OFF.
2. Disconnect the moonroof motor assembly connector R4 and moonroof switch connector R9.
3. Check continuity between the moonroof motor assembly connector R4 terminals 7 and 8 and moonroof switch connector R9 terminals 3 and 10.

Moonroof motor assembly	Terminal	Moonroof switch	Terminal	Continuity
R4	7	R9	3	Yes
	8		10	

4. Check continuity between the moonroof motor assembly connector R4 terminals 7 and 8 and ground.

Moonroof motor assembly	Terminal	(-)	Continuity
R4	7	Ground	No
	8		

Is the inspection result normal?

YES >> GO TO 5.

NO >> Repair or replace harness.

5. CHECK MOONROOF SWITCH GROUND CIRCUIT

1. Connect moonroof motor assembly.
2. Check continuity between the moonroof switch connector R9 terminal 6 and ground.

Moonroof switch connector	Terminal	(-)	Continuity
R9	6	Ground	Yes

Is the inspection result normal?

YES >> Refer to [RF-30. "Component Inspection"](#).

NO >> Repair or replace harness.

6. CHECK COMBINATION METER SIGNAL

1. Connect the moonroof motor assembly connector.
2. Turn ignition switch ON.
3. Check the signal between the moonroof motor assembly connector R4 terminal 4 and ground with oscilloscope.

POWER SUPPLY AND GROUND CIRCUIT

< DTC/CIRCUIT DIAGNOSIS >

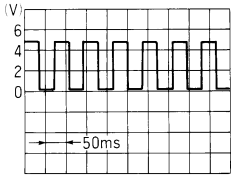
Terminals		Condition	Signal (Reference value)
(+)	(-)		
Moonroof motor assembly	Terminal	Speedometer operated [When vehicle speed is approx.40km/h (25MPH)]	 ELF1080D
R4	4		

Is the inspection result normal?

YES >> Replace moonroof motor assembly. Refer to [RF-49, "Removal and Installation"](#).

NO >> GO TO 7.

7. CHECK COMBINATION METER CIRCUIT

- Turn ignition switch OFF.
- Disconnect combination meter connector M24 and moonroof motor assembly connector R4.
- Check continuity between combination meter connector M24 terminal 38 and the moonroof motor assembly connector R4 terminal 4.

Combination meter	Terminal	Moonroof motor assembly	Terminal	Continuity
M24	38	R4	4	Yes

- Check continuity between the combination meter connector M24 terminal 38 and ground.

Combination meter connector	Terminal	(-)	Continuity
M24	38	Ground	No

Is the inspection result normal?

YES >> Replace combination meter. Refer to [MWI-72, "Removal and Installation"](#).

NO >> Repair or replace harness.

MOONROOF MOTOR ASSEMBLY : Special Repair Requirement

INFOID:000000012876215

RF

1. PERFORM INITIALIZATION PROCEDURE

Perform the initialization procedure.

Refer to [RF-27, "MOONROOF MOTOR ASSEMBLY : Special Repair Requirement"](#).

>> GO TO 2.

2. CHECK ANTI-PINCH OPERATION

Check the anti-pinch operation.

Refer to [RF-27, "MOONROOF MOTOR ASSEMBLY : Special Repair Requirement"](#).

Is the inspection result normal?

YES >> Inspection End.

NO >> Check fitting adjustment.

SUNSHADE MOTOR ASSEMBLY

SUNSHADE MOTOR ASSEMBLY : Description

INFOID:000000012876216

- BCM supplies the sunshade motor assembly with power.
- CPU is integrated in sunshade motor assembly.
- Slide open/close controlled by the moonroof switch operation.

POWER SUPPLY AND GROUND CIRCUIT

< DTC/CIRCUIT DIAGNOSIS >

SUNSHADE MOTOR ASSEMBLY : Component Function Check

INFOID:000000012876217

1. CHECK SUNSHADE MOTOR FUNCTION

Does the slide open and close functions operate normally with the moonroof switch?

Is the inspection result normal?

YES >> Sunshade motor assembly is OK.

NO >> Refer to [RF-28, "SUNSHADE MOTOR ASSEMBLY : Diagnosis Procedure"](#).

SUNSHADE MOTOR ASSEMBLY : Diagnosis Procedure

INFOID:000000012876218

Regarding Wiring Diagram information, refer to [RF-16, "Wiring Diagram"](#).

1. CHECK POWER SUPPLY

1. Turn ignition switch OFF.
2. Disconnect sunshade motor assembly connector R5.
3. Turn ignition switch ON.
4. Check voltage between sunshade motor assembly harness connector R5 terminal 1 and ground.

(+)		(-)	Voltage (Approx.)
Sunshade motor assembly			
Connector	Terminal		
R5	1	Ground	Battery voltage

Is the inspection result normal?

YES >> GO TO 2.

NO >> Repair or replace the harness.

2. CHECK GROUND CIRCUIT

1. Turn ignition switch OFF.
2. Check continuity between sunshade motor assembly harness connector R5 terminal 5 and ground.

Sunshade motor assembly		(-)	Continuity
Connector	Terminal		
R5	5	Ground	Yes

Is the inspection result normal?

YES >> Replace sunshade motor assembly. Refer to [RF-58, "Removal and Installation"](#).

NO >> Repair or replace the harness.

MOONROOF SWITCH

< DTC/CIRCUIT DIAGNOSIS >

MOONROOF SWITCH

Description

INFOID:0000000012876219

Transmits switch operation signal to moonroof motor and sunshade motor assembly.

Diagnosis Procedure

INFOID:0000000012876220

Regarding Wiring Diagram information, refer to [RF-16, "Wiring Diagram"](#).

1. CHECK MOONROOF SWITCH INPUT SIGNAL

1. Turn ignition switch ON.
2. Check voltage between moonroof motor assembly harness connector R4 terminals 2, 7, 8 and 3 and ground.

(+)		(-)	Condition	Voltage (Approx.)
Moonroof motor assembly				
Connector	Terminals			
R4	7	Ground	Moonroof switch is operated OPEN (1st)	0V
			Other than above	Battery voltage
	8		Moonroof switch is operated CLOSE (2nd)	0V
			Other than above	Battery voltage
	2		Moonroof switch is operated OPEN or CLOSE (2nd click to open sunshade)	0V
			Other than above	Battery voltage
	3		Moonroof switch is operated OPEN or CLOSE (2nd click to close sunshade)	0V
			Other than above	Battery voltage

Is the inspection result normal?

- YES >> Inspection End.
NO >> GO TO 2.

2. CHECK MOONROOF SWITCH CIRCUIT

1. Turn ignition switch OFF.
2. Disconnect moonroof motor assembly connector R4 and moonroof switch connector R9.
3. Check continuity between moonroof motor assembly harness connector R4 terminals 2, 7, 8 and 3 and moonroof switch harness connector R9 terminals 1, 3, 10 and 8.

Moonroof motor assembly		Moonroof switch		Continuity
Connector	Terminal	Connector	Terminal	
R4	2	R9	1	Yes
	7		3	
	8		10	
	3		8	

4. Check continuity between moonroof motor assembly harness connector R4 terminals 2, 7, 8 and 3 and ground.

MOONROOF SWITCH

< DTC/CIRCUIT DIAGNOSIS >

Moonroof motor assembly		(-)	Continuity
Connector	Terminal		
R4	2	Ground	No
	7		
	8		
	3		

Is the inspection result normal?

YES >> GO TO 3.

NO >> Repair or replace the harness.

3.CHECK MOONROOF SWITCH GROUND CIRCUIT

Check continuity between moonroof switch harness connector R9 terminal 6 and ground.

Moonroof switch		(-)	Continuity
Connector	Terminal		
R9	6	Ground	Yes

Is the inspection result normal?

YES >> GO TO 4.

NO >> Repair or replace the harness.

4.CHECK MOONROOF SWITCH

Check moonroof switch.

Refer to [RF-30, "Component Inspection"](#).

Is the inspection result normal?

YES >> GO TO 5.

NO >> Replace moonroof switch. Refer to [RF-60, "Removal and Installation"](#).

5.CHECK INTERMITTENT INCIDENT

Refer to [GI-42, "Intermittent Incident"](#).

>> Inspection End.

Component Inspection

INFOID:0000000012876221

MOONROOF SWITCH

1. CHECK MOONROOF SWITCH

1. Turn ignition switch OFF.
2. Disconnect moonroof switch.
3. Check continuity between moonroof switch terminals.

Terminals	Condition	Continuity
3	Moonroof switch is operated - OPEN	Yes
	Other than above	No
10	Moonroof switch is operated - CLOSE	Yes
	Other than above	No
1	Moonroof switch is operated - HOLD OPEN or HOLD CLOSE	Yes
	Other than above	No
8	Moonroof switch is operated - HOLD OPEN or HOLD CLOSE	Yes
	Other than above	No

Is the inspection result normal?

YES >> Moonroof switch is OK.

MOONROOF SWITCH

< DTC/CIRCUIT DIAGNOSIS >

NO >> Replace moonroof switch. Refer to [RF-60. "Removal and Installation"](#).

A

B

C

D

E

F

G

H

I

J

RF

L

M

N

O

P

DOOR SWITCH

< DTC/CIRCUIT DIAGNOSIS >

DOOR SWITCH

Component Function Check

INFOID:000000013387433

1.CHECK FUNCTION

CONSULT

1. Select "DOOR LOCK" of "BCM".
2. Select "DOOR SW-DR", "DOOR SW-AS", "DOOR SW-RL" or "DOOR SW-RR" in "Data Monitor" mode.
3. Check that the function operates normally according to the following conditions:

Monitor Item	Condition		Status
DOOR SW-DR	Front door LH	Open	On
		Closed	Off
DOOR SW-AS	Front door RH	Open	On
		Closed	Off
DOOR SW-RL	Rear door LH	Open	On
		Closed	Off
DOOR SW-RR	Rear door RH	Open	On
		Closed	Off

Is the inspection result normal?

- YES >> Door switch is OK.
 NO >> Refer to [RF-32, "Diagnosis Procedure"](#).

Diagnosis Procedure

INFOID:000000013387434

Regarding Wiring Diagram information, refer to [DLK-75, "Wiring Diagram"](#).

1.CHECK DOOR SWITCH INPUT SIGNAL

1. Turn ignition switch OFF.
2. Disconnect malfunctioning door switch connector.
3. Check signal between malfunctioning door switch harness connector and ground using oscilloscope.

(+)		Terminal	(-)	Signal (Reference value)
Door switch				
Connector		3	Ground	
Front LH	B8			
Front RH	B108			
Rear LH	B18			
Rear RH	B116			

Is the inspection result normal?

- YES >> GO TO 3.
 NO >> GO TO 2.

2.CHECK DOOR SWITCH CIRCUIT

1. Disconnect BCM connector.
2. Check continuity between door switch harness connector and BCM harness connector.

DOOR SWITCH

< DTC/CIRCUIT DIAGNOSIS >

Door switch		BCM		Continuity
Connector	Terminal	Connector	Terminal	
Front LH	B8	3	M20	96
Front RH	B108			94
Rear LH	B18			82
Rear RH	B116			93

3. Check continuity between door switch harness connector and ground.

Door switch		Ground	Continuity
Connector	Terminal		
Front LH	B8	3	No
Front RH	B108		
Rear LH	B18		
Rear RH	B116		

Is the inspection result normal?

YES >> Replace BCM. Refer to [BCS-79. "Removal and Installation"](#).

NO >> Repair or replace harness.

3.CHECK DOOR SWITCH

Refer to [RF-33. "Component Inspection"](#).

Is the inspection result normal?

YES >> GO TO 4.

NO >> Replace malfunctioning door switch. Refer to [DLK-332. "Removal and Installation"](#).

4.CHECK INTERMITTENT INCIDENT

Refer to [GI-42. "Intermittent Incident"](#).

>> Inspection End.

Component Inspection

INFOID:000000013387435

RF

1.CHECK DOOR SWITCH

1. Turn ignition switch OFF.
2. Disconnect malfunctioning door switch connector.
3. Check continuity between door switch terminals.

Door switch		Condition		Continuity
Terminal		Door switch		
3	Ground contact is part of the switch.		Pressed	No
		Released	Yes	

Is the inspection result normal?

YES >> Inspection End.

NO >> Replace malfunctioning door switch. Refer to [DLK-332. "Removal and Installation"](#).

MOONROOF DOES NOT OPERATE PROPERLY

< SYMPTOM DIAGNOSIS >

SYMPTOM DIAGNOSIS

MOONROOF DOES NOT OPERATE PROPERLY

Diagnosis Procedure

INFOID:0000000012876225

1. CHECK BCM POWER SUPPLY AND GROUND CIRCUIT

Check BCM power supply and ground circuit.

Refer to [RF-24, "BODY CONTROL SYSTEM : Diagnosis Procedure"](#).

Is the inspection result normal?

YES >> GO TO 2.

NO >> Repair or replace malfunctioning parts.

2. CHECK MOONROOF MOTOR ASSEMBLY POWER SUPPLY AND GROUND CIRCUIT

Check moonroof motor assembly power supply and ground circuit.

Refer to [RF-25, "MOONROOF MOTOR ASSEMBLY : Component Function Check"](#).

Is the inspection result normal?

YES >> Check intermittent incident. Refer to [GI-42, "Intermittent Incident"](#).

NO >> Repair or replace malfunctioning parts.

SUNSHADE SYSTEM DOES NOT OPERATE PROPERLY

< SYMPTOM DIAGNOSIS >

SUNSHADE SYSTEM DOES NOT OPERATE PROPERLY

Diagnosis Procedure

INFOID:000000012876226

1.CHECK BCM POWER SUPPLY AND GROUND CIRCUIT

Check BCM power supply and ground circuit.

Refer to [RF-24. "BODY CONTROL SYSTEM : Diagnosis Procedure"](#).

Is the inspection result normal?

YES >> GO TO 2.

NO >> Repair or replace the malfunctioning parts.

2.CHECK SUNSHADE MOTOR ASSEMBLY POWER SUPPLY AND GROUND CIRCUIT

Check sunshade motor assembly power supply and ground circuit.

Refer to [RF-28. "SUNSHADE MOTOR ASSEMBLY : Diagnosis Procedure"](#).

Is the inspection result normal?

YES >> GO TO 3.

NO >> Repair or replace the malfunctioning parts.

3.CONFIRM THE OPERATION

Confirm the operation again.

Is the result normal?

YES >> Check intermittent incident. Refer to [GI-42. "Intermittent Incident"](#).

NO >> GO TO 1.

A
B
C
D
E
F
G
H
I
J
RF
L
M
N
O
P

AUTO OPERATION DOES NOT OPERATE

< SYMPTOM DIAGNOSIS >

AUTO OPERATION DOES NOT OPERATE MOONROOF

MOONROOF : Diagnosis Procedure

INFOID:000000012876227

1. PERFORM INITIALIZATION PROCEDURE

Perform initialization procedure.

Refer to [RF-23, "ADDITIONAL SERVICE WHEN REPLACING CONTROL UNIT : Special Repair Requirement"](#).

Is the inspection result normal?

YES >> Moonroof system is normal.

NO >> GO TO 2.

2. CHECK MOONROOF SWITCH

Check moonroof switch.

Refer to [RF-29, "Diagnosis Procedure"](#).

Is the inspection result normal?

YES >> GO TO 3.

NO >> Repair or replace the malfunctioning parts.

3. CONFIRM THE OPERATION

Confirm the operation again.

Is the inspection result normal?

YES >> Check intermittent incident. Refer to [GI-42, "Intermittent Incident"](#).

NO >> GO TO 1.

SUNSHADE

SUNSHADE : Diagnosis Procedure

INFOID:000000012876228

1. PERFORM INITIALIZATION PROCEDURE

Refer to [RF-23, "ADDITIONAL SERVICE WHEN REPLACING CONTROL UNIT : Special Repair Requirement"](#).

Is the inspection result normal?

YES >> Sunshade system is normal.

NO >> GO TO 2.

2. CHECK SUNSHADE SWITCH

Check sunshade switch.

Refer to [RF-29, "Diagnosis Procedure"](#).

Is the inspection result normal?

YES >> GO TO 3.

NO >> Repair or replace the malfunctioning parts.

3. CONFIRM THE OPERATION

Confirm the operation again.

Is the result normal?

YES >> Check intermittent incident. Refer to [GI-42, "Intermittent Incident"](#).

NO >> GO TO 1.

ANTI-PINCH FUNCTION DOES NOT OPERATE

< SYMPTOM DIAGNOSIS >

ANTI-PINCH FUNCTION DOES NOT OPERATE MOONROOF

MOONROOF : Diagnosis Procedure

INFOID:000000012876229

1. PERFORM INITIALIZATION PROCEDURE

Perform initialization procedure.

Refer to [RF-23, "ADDITIONAL SERVICE WHEN REPLACING CONTROL UNIT : Special Repair Requirement"](#).

Is the inspection result normal?

YES >> GO TO 2.

NO >> Perform basic inspection. Refer to [RF-21, "Work Flow"](#).

2. RETEST THE ANTI-PINCH FUNCTION

Check anti-pinch operation. Refer to [RF-23, "ADDITIONAL SERVICE WHEN REPLACING CONTROL UNIT : Special Repair Requirement"](#).

Is the inspection result normal?

YES >> Inspection End.

NO >> Replace the moonroof motor assembly. Refer to [RF-49, "Removal and Installation"](#).

SUNSHADE

SUNSHADE : Diagnosis Procedure

INFOID:000000012876230

1. CHECK SUNSHADE MECHANISM

Check the following:

- Operation malfunction caused by sunshade mechanism deformation, pinched harness or other foreign materials
- Operation malfunction and interference with other parts by poor installation

Is the inspection result normal?

YES >> GO TO 2.

NO >> Repair or replace the malfunctioning parts.

2. PERFORM INITIALIZATION

Perform anti-pinch procedure.

Refer to [RF-23, "ADDITIONAL SERVICE WHEN REPLACING CONTROL UNIT : Special Repair Requirement"](#).

Is the inspection result normal?

YES >> GO TO 3.

NO >> GO TO 1.

3. RETEST THE ANTI-PINCH FUNCTION

Check anti-pinch operation. Refer to [RF-23, "ADDITIONAL SERVICE WHEN REPLACING CONTROL UNIT : Special Repair Requirement"](#).

Is the inspection result normal?

YES >> Inspection End.

NO >> Replace the sunshade motor assembly. Refer to [RF-58, "Removal and Installation"](#).

A
B
C
D
E
F
G
H
I
J
RF
L
M
N
O
P

RETAINED POWER OPERATION DOES NOT OPERATE PROPERLY

< SYMPTOM DIAGNOSIS >

RETAINED POWER OPERATION DOES NOT OPERATE PROPERLY

Diagnosis Procedure

INFOID:000000012876231

1. CHECK FRONT DOOR SWITCH

Check (LH and RH) front door switches.
Refer to [RF-32. "Diagnosis Procedure"](#).

Is the inspection result normal?

YES >> GO TO 2.

NO >> Repair or replace the malfunctioning parts.

2. CONFIRM THE OPERATION

Confirm the operation again.

Is the inspection result normal?

YES >> Check intermittent incident. Refer to [GI-42. "Intermittent Incident"](#).

NO >> GO TO 1.

SQUEAK AND RATTLE TROUBLE DIAGNOSES

< SYMPTOM DIAGNOSIS >

SQUEAK AND RATTLE TROUBLE DIAGNOSES

Work Flow

INFOID:000000012876232

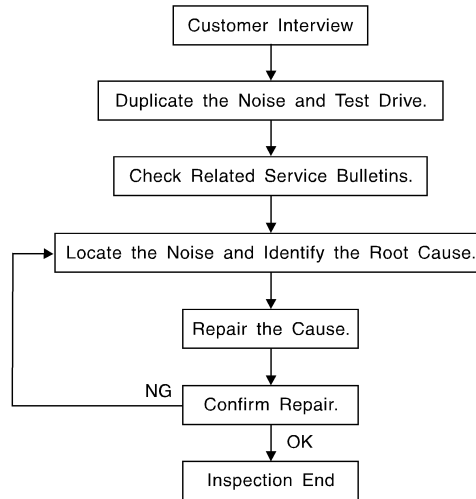

SBT842

CUSTOMER INTERVIEW

Interview the customer if possible, to determine the conditions that exist when the noise occurs. Use the Diagnostic Worksheet during the interview to document the facts and conditions when the noise occurs and any customer's comments; refer to [RF-43, "Diagnostic Worksheet"](#). This information is necessary to duplicate the conditions that exist when the noise occurs.

- The customer may not be able to provide a detailed description or the location of the noise. Attempt to obtain all the facts and conditions that exist when the noise occurs (or does not occur).
- If there is more than one noise in the vehicle, be sure to diagnose and repair the noise that the customer is concerned about. This can be accomplished by test driving the vehicle with the customer.
- After identifying the type of noise, isolate the noise in terms of its characteristics. The noise characteristics are provided so the customer, service adviser and technician are all speaking the same language when defining the noise.
- Squeak —(Like tennis shoes on a clean floor)
Squeak characteristics include the light contact/fast movement/brought on by road conditions/hard surfaces = higher pitch noise/softer surfaces = lower pitch noises/edge to surface = chirping.
- Creak—(Like walking on an old wooden floor)
Creak characteristics include firm contact/slow movement/twisting with a rotational movement/pitch dependent on materials/often brought on by activity.
- Rattle—(Like shaking a baby rattle)
Rattle characteristics include the fast repeated contact/vibration or similar movement/loose parts/missing clip or fastener/incorrect clearance.
- Knock —(Like a knock on a door)
Knock characteristics include hollow sounding/sometimes repeating/often brought on by driver action.
- Tick—(Like a clock second hand)
Tick characteristics include gentle contacting of light materials/loose components/can be caused by driver action or road conditions.
- Thump—(Heavy, muffled knock noise)
Thump characteristics include softer knock/dead sound often brought on by activity.
- Buzz—(Like a bumble bee)
Buzz characteristics include high frequency rattle/firm contact.
- Often the degree of acceptable noise level will vary depending upon the person. A noise that you may judge as acceptable may be very irritating to the customer.
- Weather conditions, especially humidity and temperature, may have a great effect on noise level.

DUPLICATE THE NOISE AND TEST DRIVE

If possible, drive the vehicle with the customer until the noise is duplicated. Note any additional information on the Diagnostic Worksheet regarding the conditions or location of the noise. This information can be used to duplicate the same conditions when you confirm the repair.

SQUEAK AND RATTLE TROUBLE DIAGNOSES

< SYMPTOM DIAGNOSIS >

If the noise can be duplicated easily during the test drive, to help identify the source of the noise, try to duplicate the noise with the vehicle stopped by doing one or all of the following:

- 1) Close a door.
 - 2) Tap or push/pull around the area where the noise appears to be coming from.
 - 3) Rev the engine.
 - 4) Use a floor jack to recreate vehicle "twist".
 - 5) At idle, apply engine load (electrical load, half-clutch on M/T model, drive position on CVT and A/T models).
 - 6) Raise the vehicle on a hoist and hit a tire with a rubber hammer.
- Drive the vehicle and attempt to duplicate the conditions the customer states exist when the noise occurs.
 - If it is difficult to duplicate the noise, drive the vehicle slowly on an undulating or rough road to stress the vehicle body.

CHECK RELATED SERVICE BULLETINS

After verifying the customer concern or symptom, check ASIST for Technical Service Bulletins (TSBs) related to that concern or symptom.

If a TSB relates to the symptom, follow the procedure to repair the noise.

LOCATE THE NOISE AND IDENTIFY THE ROOT CAUSE

1. Narrow down the noise to a general area. To help pinpoint the source of the noise, use a listening tool (Chassis Ear: J-39570, Engine Ear: J-39565 and mechanic's stethoscope).
2. Narrow down the noise to a more specific area and identify the cause of the noise by:
 - removing the components in the area that you suspect the noise is coming from.
Do not use too much force when removing clips and fasteners, otherwise clips and fasteners can be broken or lost during the repair, resulting in the creation of new noise.
 - tapping or pushing/pulling the component that you suspect is causing the noise.
Do not tap or push/pull the component with excessive force, otherwise the noise will be eliminated only temporarily.
 - feeling for a vibration with your hand by touching the component(s) that you suspect is (are) causing the noise.
 - placing a piece of paper between components that you suspect are causing the noise.
 - looking for loose components and contact marks.Refer to [RF-40. "Generic Squeak and Rattle Troubleshooting"](#).

REPAIR THE CAUSE

- If the cause is a loose component, tighten the component securely.
- If the cause is insufficient clearance between components:
 - separate components by repositioning or loosening and retightening the component, if possible.
 - insulate components with a suitable insulator such as urethane pads, foam blocks, felt cloth tape or urethane tape. A NISSAN Squeak and Rattle Kit (J-50397) is available through your authorized NISSAN Parts Department.

CAUTION:

Do not use excessive force as many components are constructed of plastic and may be damaged.

NOTE:

- Always check with the Parts Department for the latest parts information.
- The materials contained in the NISSAN Squeak and Rattle Kit (J-50397) are listed on the inside cover of the kit; and can each be ordered separately as needed.
- The following materials not found in the kit can also be used to repair squeaks and rattles.
 - SILICONE GREASE: Use instead of UHMW tape that will be visible or does not fit. The silicone grease will only last a few months.
 - SILICONE SPRAY: Use when grease cannot be applied.
 - DUCT TAPE: Use to eliminate movement.

CONFIRM THE REPAIR

Confirm that the cause of a noise is repaired by test driving the vehicle. Operate the vehicle under the same conditions as when the noise originally occurred. Refer to the notes on the Diagnostic Worksheet.

Generic Squeak and Rattle Troubleshooting

INFOID:000000012876233

Refer to Table of Contents for specific component removal and installation information.

INSTRUMENT PANEL

Most incidents are caused by contact and movement between:

SQUEAK AND RATTLE TROUBLE DIAGNOSES

< SYMPTOM DIAGNOSIS >

1. Cluster lid A and the instrument panel
2. Acrylic lens and combination meter housing
3. Instrument panel to front pillar finisher
4. Instrument panel to windshield
5. Instrument panel pins
6. Wiring harnesses behind the combination meter
7. A/C defroster duct and duct joint

These incidents can usually be located by tapping or moving the components to duplicate the noise or by pressing on the components while driving to stop the noise. Most of these incidents can be repaired by applying felt cloth tape or silicone spray (in hard to reach areas). Urethane pads can be used to insulate wiring harness.

CAUTION:

Do not use silicone spray to isolate a squeak or rattle. If you saturate the area with silicone, you will not be able to recheck the repair.

CENTER CONSOLE

Components to pay attention to include:

1. Shift selector assembly cover to finisher
2. A/C control unit and cluster lid C
3. Wiring harnesses behind audio and A/C control unit

The instrument panel repair and isolation procedures also apply to the center console.

DOORS

Pay attention to the:

1. Finisher and inner panel making a slapping noise
2. Inside handle escutcheon to door finisher
3. Wiring harnesses tapping
4. Door striker out of alignment causing a popping noise on starts and stops

Tapping or moving the components or pressing on them while driving to duplicate the conditions can isolate many of these incidents. You can usually insulate the areas with felt cloth tape or insulator foam blocks from the NISSAN Squeak and Rattle Kit (J-50397) to repair the noise.

TRUNK

Trunk noises are often caused by a loose jack or loose items put into the trunk by the owner.

In addition look for:

1. Trunk lid bumpers out of adjustment
2. Trunk lid striker out of adjustment
3. The trunk lid torsion bars knocking together
4. A loose license plate or bracket

Most of these incidents can be repaired by adjusting, securing or insulating the item(s) or component(s) causing the noise.

SUNROOF/HEADLINING

Noises in the sunroof/headlining area can often be traced to one of the following:

1. Sunroof lid, rail, linkage or seals making a rattle or light knocking noise
2. Sun visor shaft shaking in the holder
3. Front or rear windshield touching headliner and squeaking

Again, pressing on the components to stop the noise while duplicating the conditions can isolate most of these incidents. Repairs usually consist of insulating with felt cloth tape.

OVERHEAD CONSOLE (FRONT AND REAR)

Overhead console noises are often caused by the console panel clips not being engaged correctly. Most of these incidents are repaired by pushing up on the console at the clip locations until the clips engage.

In addition look for:

1. Loose harness or harness connectors.
2. Front console map/reading lamp lens loose.

A
B
C
D
E
F
G
H
I
J
RF
L
M
N
O
P

SQUEAK AND RATTLE TROUBLE DIAGNOSES

< SYMPTOM DIAGNOSIS >

3. Loose screws at console attachment points.

SEATS

When isolating seat noise it's important to note the position the seat is in and the load placed on the seat when the noise is present. These conditions should be duplicated when verifying and isolating the cause of the noise.

Cause of seat noise include:

1. Headrest rods and holder
2. A squeak between the seat pad cushion and frame
3. The rear seatback lock and bracket

These noises can be isolated by moving or pressing on the suspected components while duplicating the conditions under which the noise occurs. Most of these incidents can be repaired by repositioning the component or applying urethane tape to the contact area.

UNDERHOOD

Some interior noise may be caused by components under the hood or on the engine wall. The noise is then transmitted into the passenger compartment.

Causes of transmitted underhood noise include:

1. Any component installed to the engine wall
2. Components that pass through the engine wall
3. Engine wall mounts and connectors
4. Loose radiator installation pins
5. Hood bumpers out of adjustment
6. Hood striker out of adjustment

These noises can be difficult to isolate since they cannot be reached from the interior of the vehicle. The best method is to secure, move or insulate one component at a time and test drive the vehicle. Also, engine rpm or load can be changed to isolate the noise. Repairs can usually be made by moving, adjusting, securing, or insulating the component causing the noise.

SQUEAK AND RATTLE TROUBLE DIAGNOSES

< SYMPTOM DIAGNOSIS >

Diagnostic Worksheet

INFOID:000000012876234

Dear Customer:

We are concerned about your satisfaction with your vehicle. Repairing a squeak or rattle sometimes can be very difficult. To help us fix your vehicle right the first time, please take a moment to note the area of the vehicle where the squeak or rattle occurs and under what conditions. You may be asked to take a test drive with a service advisor or technician to ensure we confirm the noise you are hearing.

SQUEAK & RATTLE DIAGNOSTIC WORKSHEET

I. WHERE DOES THE NOISE COME FROM? (circle the area of the vehicle)

The illustrations are for reference only, and may not reflect the actual configuration of your vehicle.

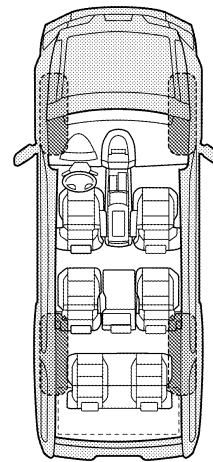
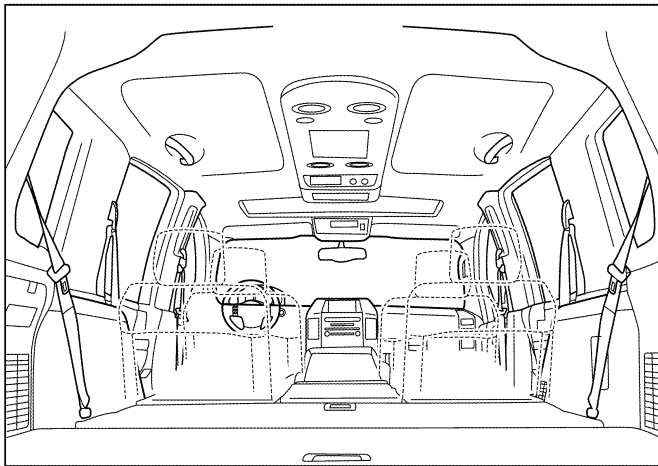
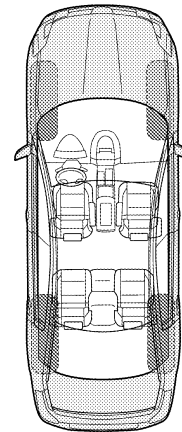
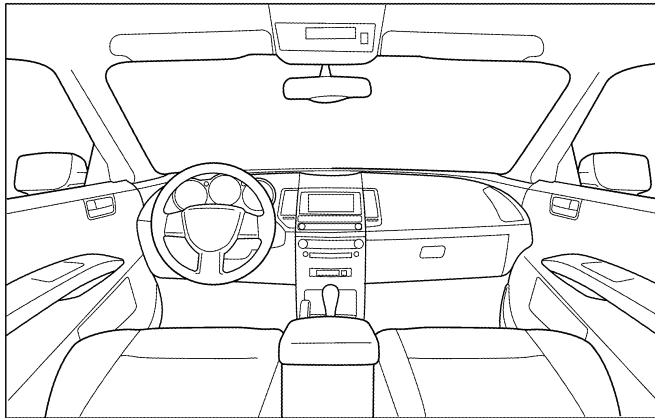

Continue to page 2 of the worksheet and briefly describe the location of the noise or rattle. In addition, please indicate the conditions which are present when the noise occurs.

A
B
C
D
E
F
G
H
I
J
RF
L
M
N
O
P

SQUEAK AND RATTLE TROUBLE DIAGNOSES

< SYMPTOM DIAGNOSIS >

SQUEAK & RATTLE DIAGNOSTIC WORKSHEET - page 2

Briefly describe the location where the noise occurs:

II. WHEN DOES IT OCCUR? (please check the boxes that apply)

- | | |
|---|--|
| <input type="checkbox"/> Anytime | <input type="checkbox"/> After sitting out in the rain |
| <input type="checkbox"/> 1st time in the morning | <input type="checkbox"/> When it is raining or wet |
| <input type="checkbox"/> Only when it is cold outside | <input type="checkbox"/> Dry or dusty conditions |
| <input type="checkbox"/> Only when it is hot outside | <input type="checkbox"/> Other: |

III. WHEN DRIVING:

- Through driveways
- Over rough roads
- Over speed bumps
- Only about ____ mph
- On acceleration
- Coming to a stop
- On turns: left, right or either (circle)
- With passengers or cargo
- Other: _____
- After driving ____ miles or ____ minutes

IV. WHAT TYPE OF NOISE

- Squeak (like tennis shoes on a clean floor)
- Creak (like walking on an old wooden floor)
- Rattle (like shaking a baby rattle)
- Knock (like a knock at the door)
- Tick (like a clock second hand)
- Thump (heavy muffled knock noise)
- Buzz (like a bumble bee)

TO BE COMPLETED BY DEALERSHIP PERSONNEL

Test Drive Notes:

	YES	NO	Initials of person performing
Vehicle test driven with customer	<input type="checkbox"/>	<input type="checkbox"/>	_____
- Noise verified on test drive	<input type="checkbox"/>	<input type="checkbox"/>	_____
- Noise source located and repaired	<input type="checkbox"/>	<input type="checkbox"/>	_____
- Follow up test drive performed to confirm repair	<input type="checkbox"/>	<input type="checkbox"/>	_____

VIN: _____ Customer Name _____
W.O.# _____ Date: _____

This form must be attached to Work Order

LAI0071E

GLASS LID

< REMOVAL AND INSTALLATION >



REMOVAL AND INSTALLATION

GLASS LID

Exploded View

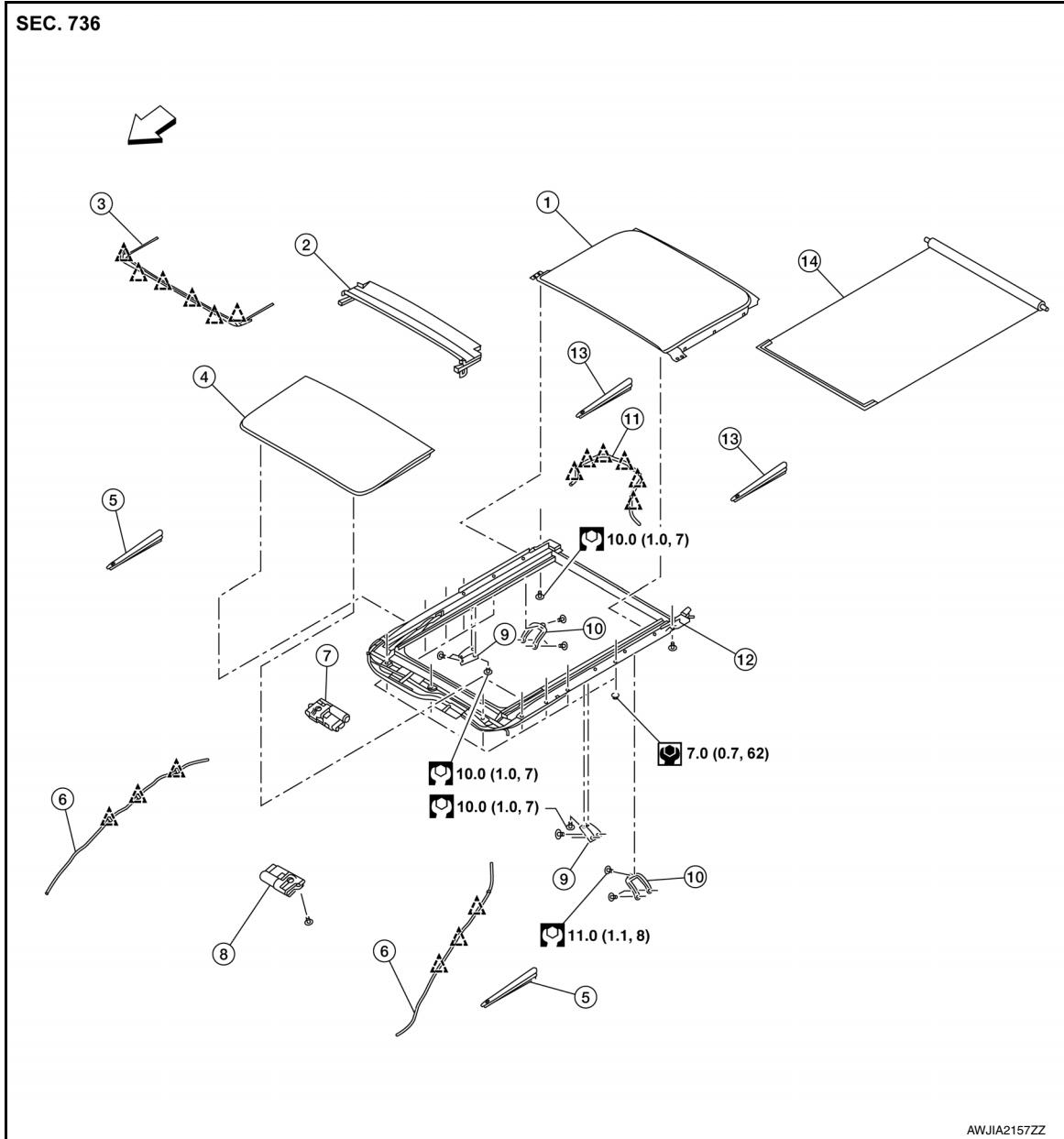
INFOID:000000012876235



- | | | |
|-----------------------------------|-----------------------------|-----------------------------------|
| 1. Panoramic roof glass | 2. Moonroof drain | 3. Wind deflector |
| 4. Glass lid | 5. Side trim covers (LH/RH) | 6. Front drain hose (LH/RH) |
| 7. Moonroof motor assembly | 8. Sunshade motor assembly | 9. Moonroof front bracket (LH/RH) |
| 10. Moonroof rear bracket (LH/RH) | 11. Rear drain hose (LH/RH) | 12. Moonroof unit assembly |
| 13. Rear trim covers (LH/RH) | 14. Sunshade | ⇐ Front |
-  Pawl
  Clip

Removal and Installation

INFOID:000000012876236

CAUTION:
Handle glass lid with care to prevent damage.

A
B
C
D
E
F
G
H
I
J
K
L
M
N
O
P

RF

GLASS LID

< REMOVAL AND INSTALLATION >

REMOVAL

1. Open sunshade (1) and close glass lid.
⇐ Front
2. Slide the side trim covers (2) (LH/RH) inward, then release from the glass lid inside edge and set aside.
3. Remove the glass lid bolts (A) on the (LH/RH) sides.

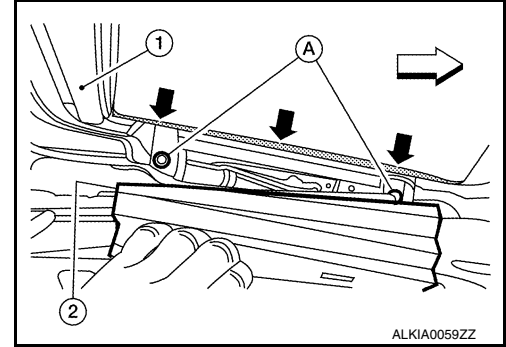

4. Remove glass lid from moonroof unit assembly.

INSTALLATION

Installation is in the reverse order of removal.

CAUTION:

- **First tighten left front bolt, then right rear bolt to prevent uneven alignment while tightening remaining bolt.**
- **After installing glass lid, check gap/height adjustments and operation. Refer to [RF-51, "Inspection"](#).**

PANORAMIC ROOF GLASS



< REMOVAL AND INSTALLATION >

PANORAMIC ROOF GLASS

Exploded View

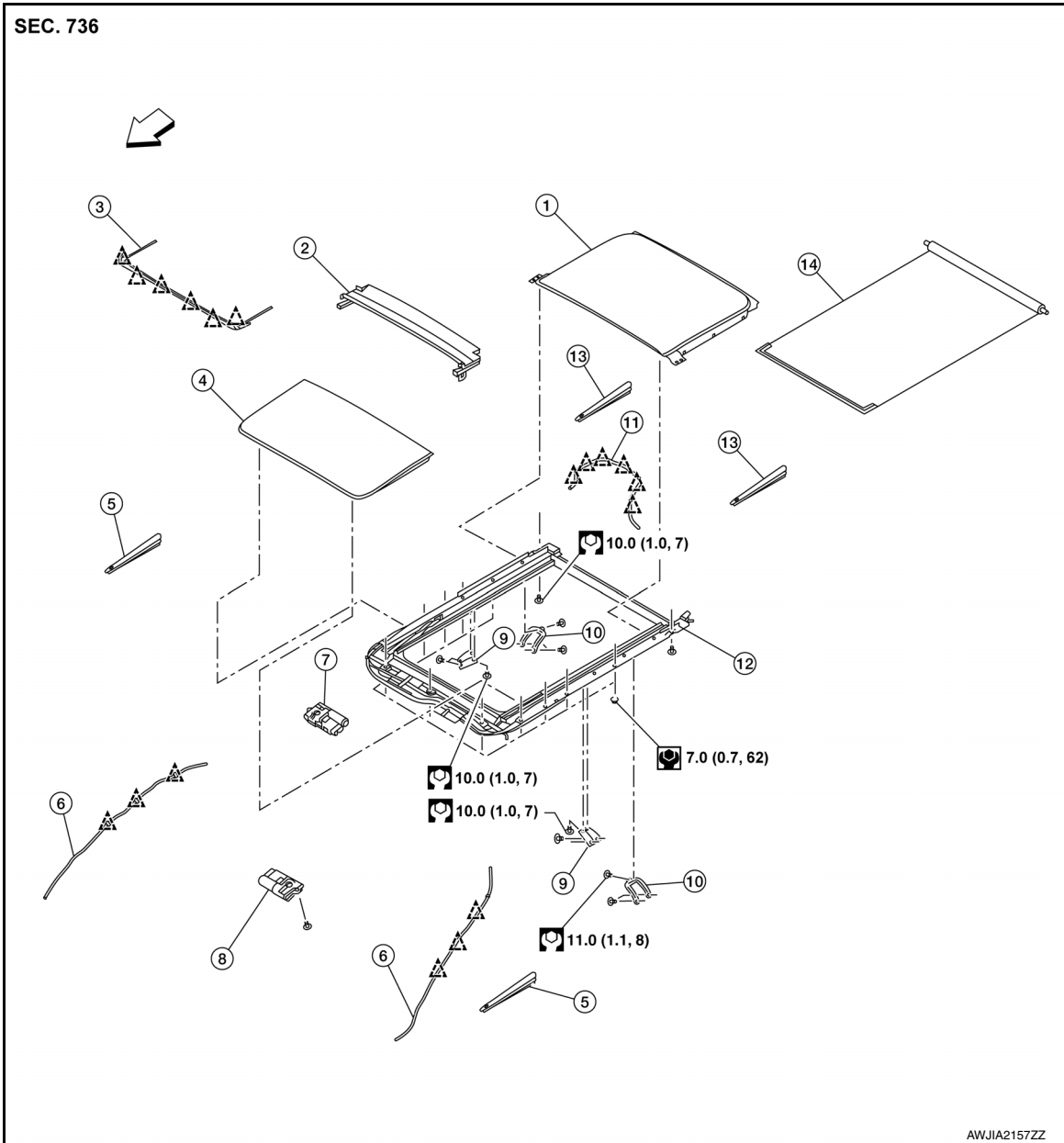
INFOID:000000012876237



- | | | |
|-----------------------------------|-----------------------------|-----------------------------------|
| 1. Panoramic roof glass | 2. Moonroof drain | 3. Wind deflector |
| 4. Glass lid | 5. Side trim covers (LH/RH) | 6. Front drain hose (LH/RH) |
| 7. Moonroof motor assembly | 8. Sunshade motor assembly | 9. Moonroof front bracket (LH/RH) |
| 10. Moonroof rear bracket (LH/RH) | 11. Rear drain hose (LH/RH) | 12. Moonroof unit assembly |
| 13. Rear trim covers (LH/RH) | 14. Sunshade | ⇐ Front |
-  Pawl
  Clip

Removal and Installation

INFOID:000000012876238

CAUTION:
Handle panoramic roof glass with care to prevent damage.

REMOVAL

A
B
C
D
E
F
G
H
I
J
RF
L
M
N
O
P

PANORAMIC ROOF GLASS

< REMOVAL AND INSTALLATION >

1. Remove moonroof unit assembly. Refer to [RF-55, "Removal and Installation"](#).
2. Slide side trim covers LH/RH inward, then release from the panoramic roof glass edge and set aside.
3. Remove four screws and panoramic roof glass.

INSTALLATION

Installation is in the reverse order of removal.

CAUTION:

- **First tighten left front screw, then right rear screw to prevent uneven alignment while tightening remaining screws.**
- **After installing panoramic roof glass, check gap/height adjustments and operation. Refer to [RF-51, "Inspection"](#).**

MOONROOF MOTOR ASSEMBLY



< REMOVAL AND INSTALLATION >

MOONROOF MOTOR ASSEMBLY

Exploded View

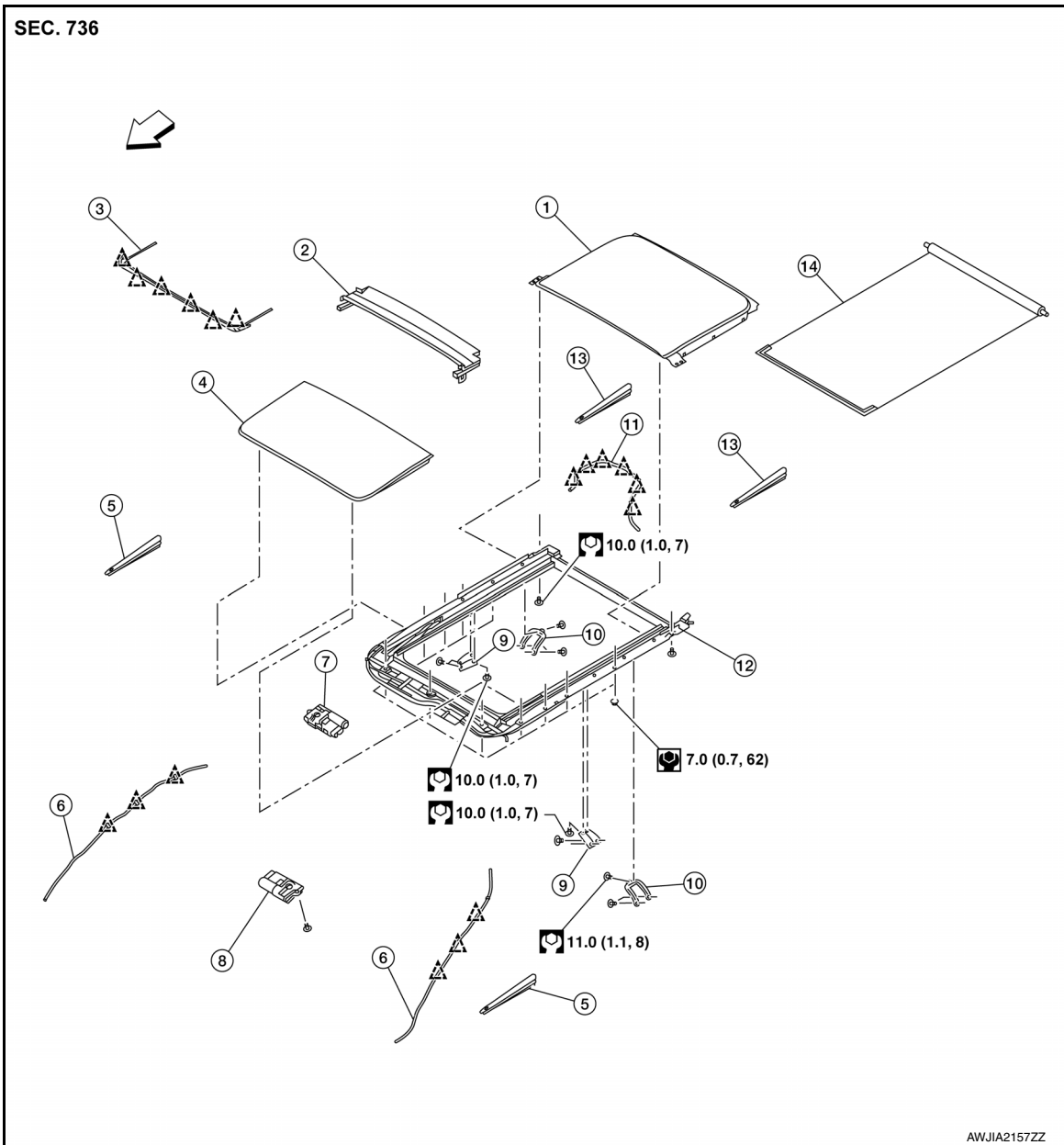
INFOID:000000012876239



- | | | |
|-----------------------------------|-----------------------------|-----------------------------------|
| 1. Panoramic roof glass | 2. Moonroof drain | 3. Wind deflector |
| 4. Glass lid | 5. Side trim covers (LH/RH) | 6. Front drain hose (LH/RH) |
| 7. Moonroof motor assembly | 8. Sunshade motor assembly | 9. Moonroof front bracket (LH/RH) |
| 10. Moonroof rear bracket (LH/RH) | 11. Rear drain hose (LH/RH) | 12. Moonroof unit assembly |
| 13. Rear trim covers (LH/RH) | 14. Sunshade | ↔ Front |
-  Pawl
  Clip

Removal and Installation

INFOID:000000012876240

REMOVAL

1. Close glass lid.
2. Remove the headlining. Refer to [INT-27, "Removal and Installation"](#).

MOONROOF MOTOR ASSEMBLY

< REMOVAL AND INSTALLATION >

3. Disconnect harness connector (A) from moonroof motor assembly (1).

CAUTION:

Do not run the removed moonroof motor assembly as a single unit.

4. Remove moonroof motor assembly screws (B) and release from moonroof unit assembly (2)

↔: Front

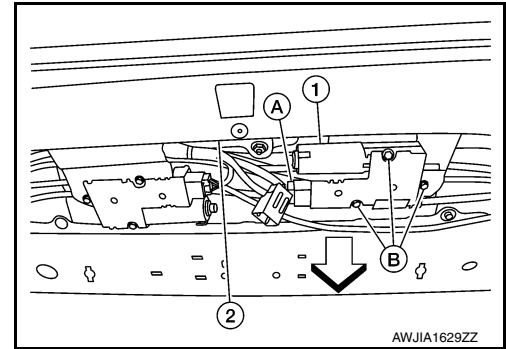

INSTALLATION

1. Move moonroof motor assembly laterally little by little so that the gear is completely engaged into the wire on the moonroof unit assembly, and the mounting surfaces become parallel. Install the moonroof motor assembly screws and tighten.

CAUTION:

Before installing the moonroof motor unit, be sure to place the link and wire assembly in the symmetrical and fully closed position.

NOTE:

If necessary, insert a suitable tool into the drive key and rotate right or left slightly to assist in complete moonroof motor gear alignment.

2. Remainder of installation is in the reverse order of removal.
3. Synchronize moonroof motor assembly with moonroof unit assembly. Refer to [RF-23, "ADDITIONAL SERVICE WHEN REPLACING CONTROL UNIT : Special Repair Requirement"](#).

MOONROOF UNIT ASSEMBLY

< REMOVAL AND INSTALLATION >

MOONROOF UNIT ASSEMBLY

Inspection

INFOID:000000012876241

WIND DEFLECTOR

1. Open glass lid fully.
2. Visually check for proper installation, damaged/deteriorated components, or foreign objects within mechanism. Correct as required for smooth operation.
3. Check for grease at the wind deflector arm (1) and pivot areas. If necessary, apply a sufficient amount of grease for non-binding operation.
⇐: Front

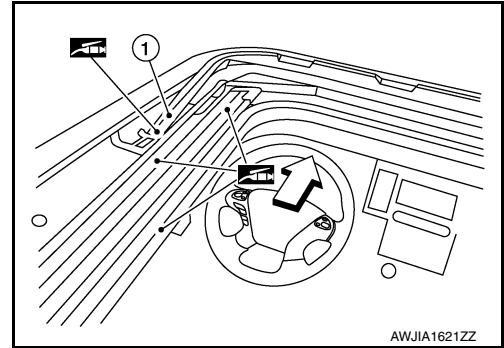

4. Check that the wind deflector (1) moves freely within the moonroof unit assembly while manually pressing down and releasing. If a malfunction is detected, remove the moonroof unit assembly and visually inspect. If damage is found, replace either wind deflector (1) or moonroof unit assembly as required. Refer to [RF-59, "Removal and Installation"](#) (WIND DEFLECTOR) or [RF-55, "Removal and Installation"](#) (MOONROOF UNIT ASSEMBLY).
⇐: Front

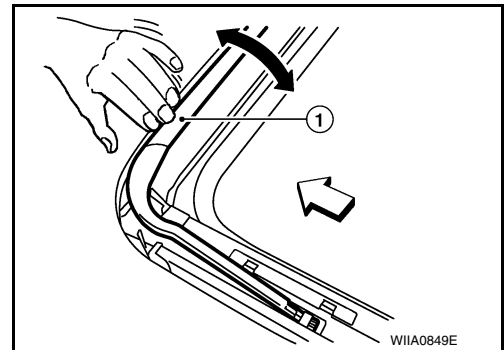

LINK AND WIRE ASSEMBLY

NOTE:

Before replacing a suspect part, make sure it is the source of noise being experienced.

1. Check link to determine if coating film has peeled off excessively enough that substrate is visible. Check also to determine if link is the source of noise. Replace as necessary.
2. Visually check to determine if a sufficient amount of grease has been applied to wire or rail groove. If not, add grease as required.
3. Check wire for any damage or deterioration. If any damage is found, replace moonroof unit assembly. Refer to [RF-55, "Removal and Installation"](#)

WEATHERSTRIP

1. Visually check weatherstrip for damage, deterioration, or deformation.
 - Open glass lid partially to inspect front edge of weatherstrip.
 - Tilt up glass lid fully to inspect sides and rear edge of weatherstrip.If any area of the weatherstrip is found to be damaged, replace the glass lid. Refer to [RF-45, "Removal and Installation"](#).
2. Check for leaks around glass lid.
 - Close glass lid.
 - Pour water around surface to determine area of concern.
 - For gaps or misalignment, adjust glass lid to specifications. Refer to ADJUSTMENT in this section.
 - For damaged sealing surfaces, either replace glass lid, refer to [RF-45, "Removal and Installation"](#) or repair the panel.

DRAIN HOSES

A
B
C
D
E
F
G
H
I
J

RF

L
M
N
O
P

MOONROOF UNIT ASSEMBLY

< REMOVAL AND INSTALLATION >

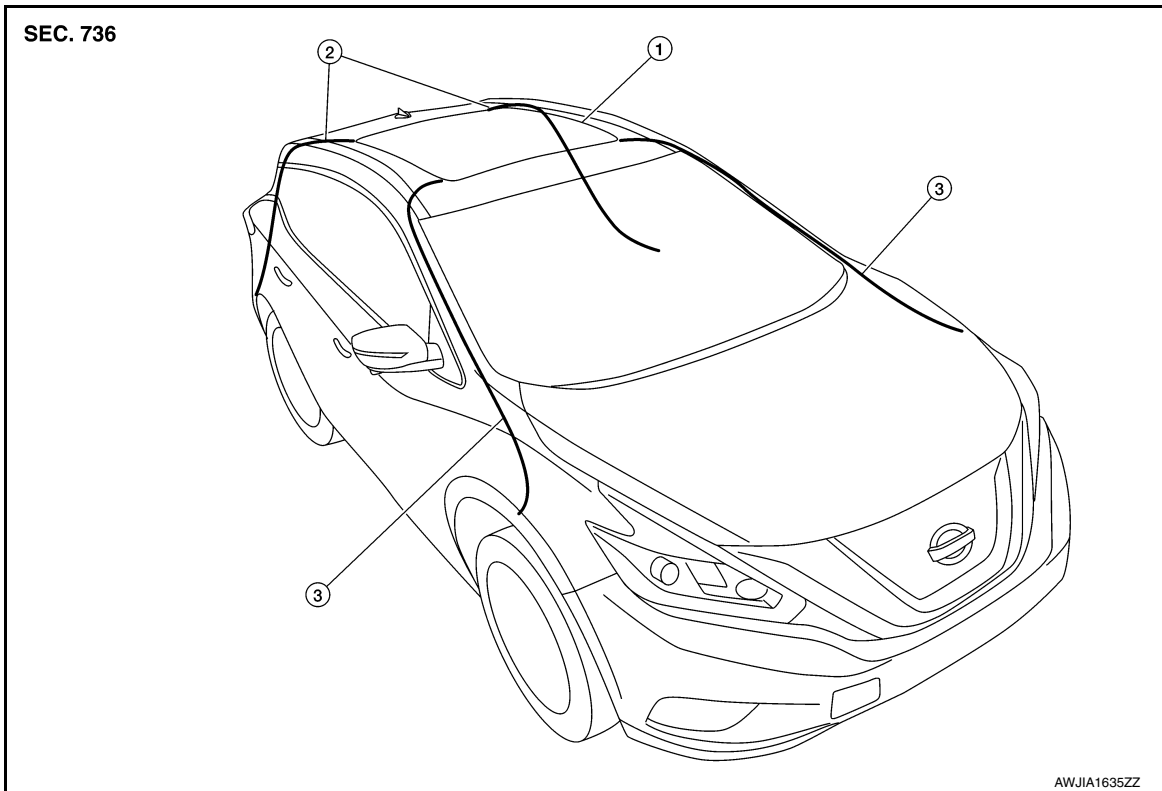

1. Moonroof unit assembly 2. Rear drain hoses (LH/RH) 3. Front drain hoses (LH/RH)

1. Remove the headlining. Refer to [INT-27. "Removal and Installation"](#).
2. From the inside front pillar (3) visually check drain hoses (1) for:
 - Proper connection at moonroof unit assembly (4) and drain hose connection at the exit base (2).
 - Damage, pinch, cracks, deterioration.

⇐: Front

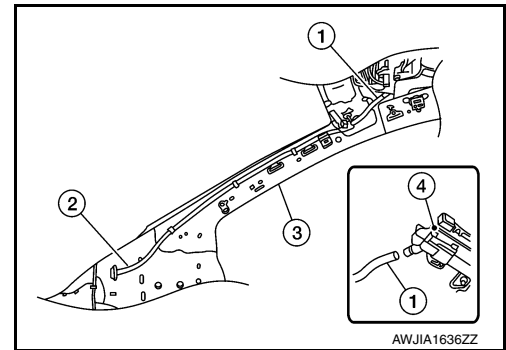

3. Pour water through drain hoses to determine watertight performance. If damaged or leaking portions in any drain hose is found, replace entire drain hose as necessary.
4. From the inside of the rear panel (1) visually check drain hoses (2) for damage, pinching, cracks, or deterioration.
5. Check for proper connection at moonroof unit assembly (3) and drain hose (2) and for proper routing along the rear panel (1).

⇐: Front

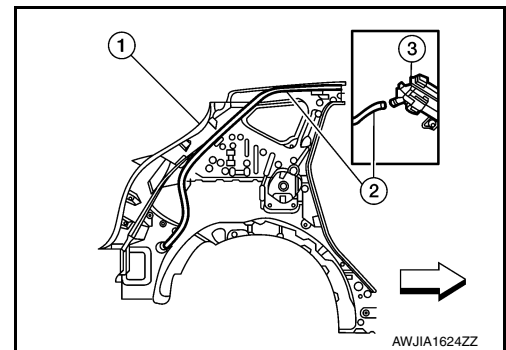

ADJUSTMENT

CAUTION:

- Always work with a helper.

MOONROOF UNIT ASSEMBLY

< REMOVAL AND INSTALLATION >

- Handle glass lid with care to prevent damage.

NOTE:

- For easier and more accurate installation, always mark each point before removal.
- After any adjustment, check moonroof operation and glass lid alignment.

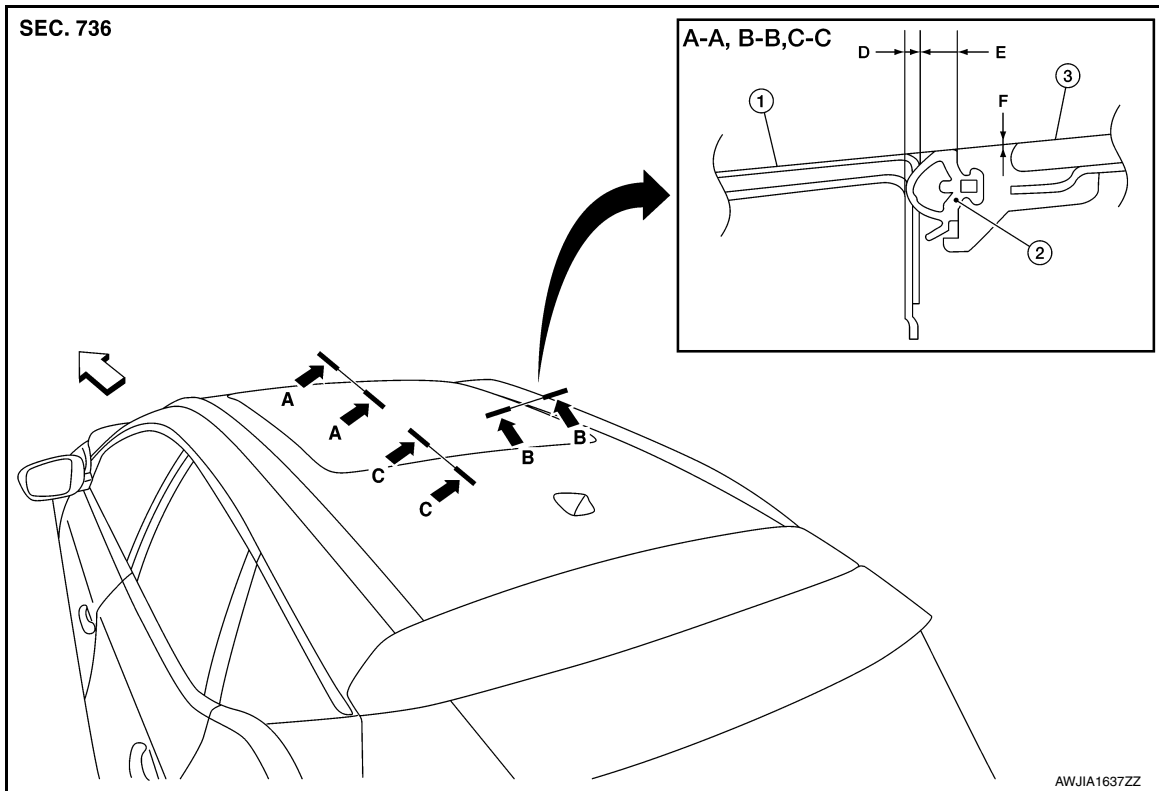

1. Roof panel

2. Weatherstrip

3. Glass lid/panoramic roof glass

⇐ Front

Unit: mm (in)

Portion	Gap		Surface height difference
	D	E	F
A-A	1.2 ± 1.0 (0.06 ± 0.03)	3.0	0.7 ± 1.5 (0.03 ± 0.06)
B-B	1.2 ± 1.0 (0.06 ± 0.03)	3.0	0.7 ± 1.5 (0.03 ± 0.06)
C-C	1.2 ± 1.0 (0.06 ± 0.03)	3.0	0.7 ± 1.5 (0.03 ± 0.06)

Gap adjustment (Front and Rear)

1. Open sunshade (1).
⇐: Front
2. Tilt glass lid up, then release side trim cover (2) on each side and set aside.
NOTE:
LH side shown; RH similar.
3. Loosen glass lid bolts (A) (two each on LH and RH side), then tilt glass lid down.
4. Manually adjust glass lid from outside of vehicle until gaps A-A and C-C are within specification.
NOTE:

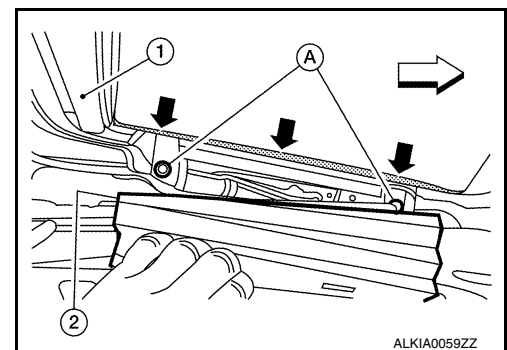

Temporarily loosely tighten glass lid bolts to prevent movement between each adjustment.

5. Tilt glass lid up and down several times using moonroof switch to check that it operates smoothly.
6. Tilt glass lid up and tighten bolts.

MOONROOF UNIT ASSEMBLY

< REMOVAL AND INSTALLATION >

NOTE:

First tighten left front bolt, then right rear bolt on glass lid to prevent uneven torque while tightening remaining bolts.

7. Attach side trim covers (LH/RH), then tilt glass lid down.

Gap Adjustment (Sides)

The moonroof unit assembly is mounted on locator pins and adjustment from side to side cannot be performed.

Surface Height Adjustment

1. Tilt glass lid up and down several times using moonroof switch to check that it operates smoothly.
2. Check height difference between roof surface and glass lid surface, then compare to specifications.
3. If necessary, adjust height difference by using the following procedure.
 - Loosen glass lid bolts.
 - Manually raise/lower glass lid until height difference is within specification.

NOTE:

If necessary, shims may be added between moonroof unit assembly and roof to increase adjustment range. Refer to [RF-55, "Removal and Installation"](#).

Temporarily loosely tighten moonroof unit assembly bolts to prevent movement between each adjustment.

- Tilt glass lid up and down several times using moonroof switch to check that it operates smoothly.
- Tighten glass lid and moonroof side bracket bolts.

NOTE:

First tighten left front bolt, then right rear bolt on glass lid to prevent uneven torque while tightening remaining bolts.

- After any adjustment, check moonroof operation and glass lid alignment.



MOONROOF UNIT ASSEMBLY

< REMOVAL AND INSTALLATION >

Exploded View

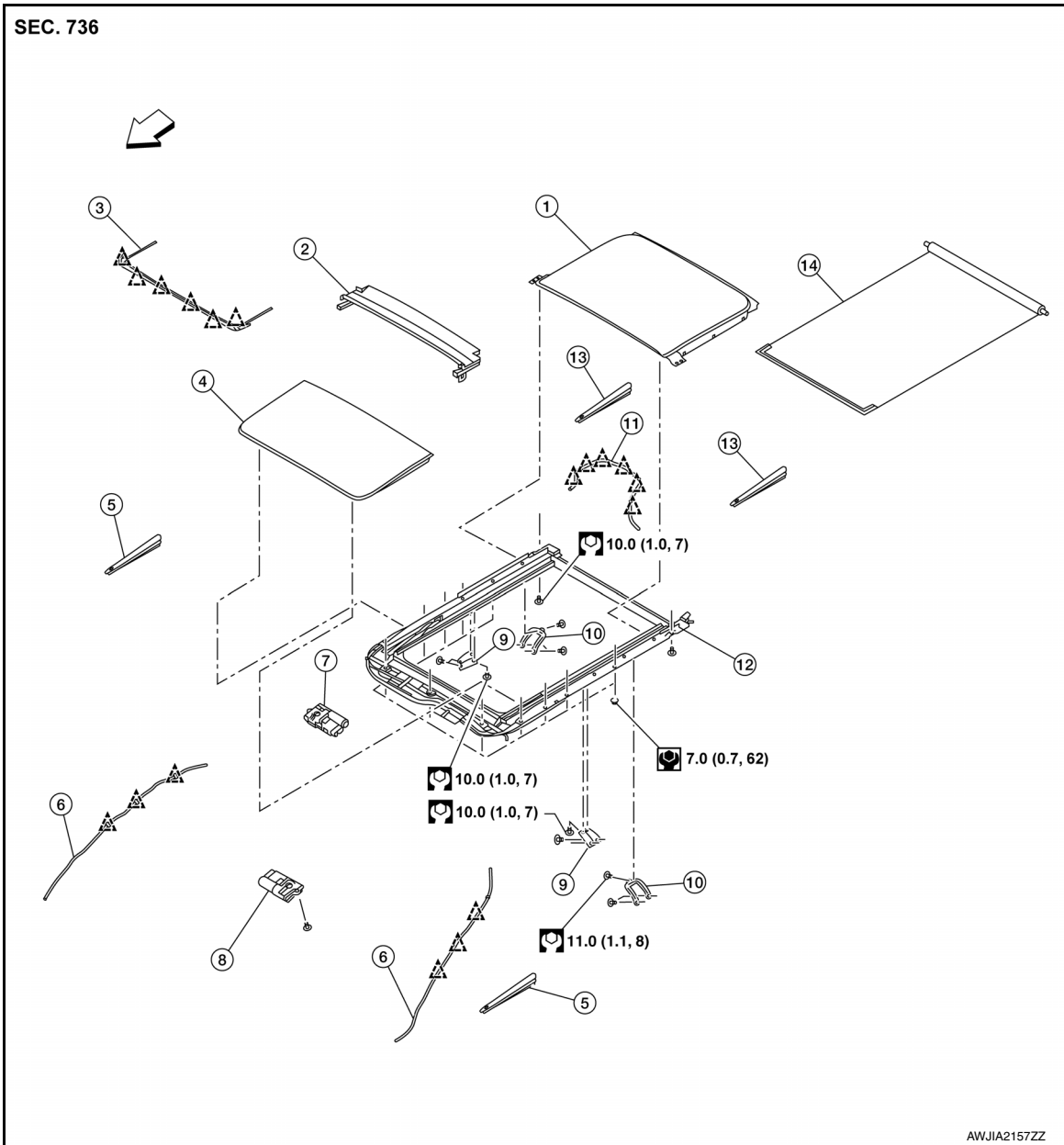
INFOID:000000012876242



- | | | |
|-----------------------------------|-----------------------------|-----------------------------------|
| 1. Panoramic roof glass | 2. Moonroof drain | 3. Wind deflector |
| 4. Glass lid | 5. Side trim covers (LH/RH) | 6. Front drain hose (LH/RH) |
| 7. Moonroof motor assembly | 8. Sunshade motor assembly | 9. Moonroof front bracket (LH/RH) |
| 10. Moonroof rear bracket (LH/RH) | 11. Rear drain hose (LH/RH) | 12. Moonroof unit assembly |
| 13. Rear trim covers (LH/RH) | 14. Sunshade | ⇐ Front |
-  Pawl
  Clip

Removal and Installation

INFOID:000000012876243

REMOVAL

CAUTION:

- Always work with a helper.
- When taking moonroof unit assembly out, use cloths to protect the seats and trim from damage.

1. Remove headlining. Refer to [INT-27, "Removal and Installation"](#).

MOONROOF UNIT ASSEMBLY

< REMOVAL AND INSTALLATION >

2. Disconnect drain hoses (front/rear) from moonroof unit assembly. Refer to [RF-51, "Inspection"](#).
3. Disconnect harness connectors from moonroof motor assembly and sunshade motor assembly.
4. Using a helper, carefully lift each side, then remove nuts and then remove moonroof unit assembly out back of vehicle.

WARNING:

Bodily injury may occur if moonroof unit assembly is not supported properly when removing.

INSTALLATION

Installation is in the reverse order of removal.

CAUTION:

After installing the moonroof unit assembly, perform the leak test and check that there is no air or water intrusion. Refer to [RF-51, "Inspection"](#).

SUNSHADE

< REMOVAL AND INSTALLATION >

SUNSHADE

Removal and Installation

INFOID:000000012876244

REMOVAL

1. Open the sunshade with approximately 8 inches showing.
2. Remove moonroof unit assembly. Refer to [RF-55, "Removal and Installation"](#).
3. Remove panoramic glass. Refer to [RF-47, "Removal and Installation"](#).
4. Release the sunshade by pushing (apply pressure) to driver side of sunshade.
5. Remove the sunshade by pulling rearward from moonroof tracks.

INSTALLATION

Installation is in the reverse order of removal.

A
B
C
D
E
F
G
H
I
J
RF
L
M
N
O
P

SUNSHADE MOTOR ASSEMBLY

< REMOVAL AND INSTALLATION >

SUNSHADE MOTOR ASSEMBLY

Removal and Installation

INFOID:000000012876245

REMOVAL

1. Remove the headlining. Refer to [INT-27, "Removal and Installation"](#).
2. Disconnect the harness connector (A) from the sunshade motor assembly (1).
3. Remove sunshade motor assembly screws (B).
4. Remove the sunshade motor assembly from the moonroof unit assembly (2).

↶: Front

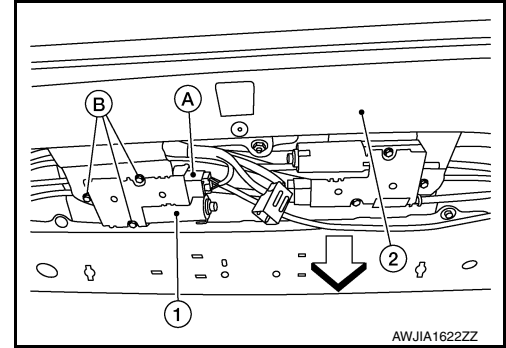

INSTALLATION

Installation is in the reverse order of removal.

- Synchronize sunshade motor assembly with moonroof unit assembly. Refer to [RF-23, "ADDITIONAL SERVICE WHEN REPLACING CONTROL UNIT : Special Repair Requirement"](#).

WIND DEFLECTOR

< REMOVAL AND INSTALLATION >

WIND DEFLECTOR

Removal and Installation

INFOID:000000012876246

REMOVAL

1. Open the glass lid to view the wind deflector.
2. Release upper clips on LH/RH side of the wind deflector.
3. Release bottom wind deflector clips.
4. Apply inward pressure on the bottom LH/RH ends of the wind deflector and remove.

INSTALLATION

Installation is in the reverse order of removal.

A

B

C

D

E

F

G

H

I

J

RF

L

M

N

O

P

MOONROOF SWITCH

< REMOVAL AND INSTALLATION >

MOONROOF SWITCH

Removal and Installation

INFOID:000000012876247

REMOVAL

1. Remove map lamp assembly. Refer to [INL-47, "Removal and Installation"](#).

2. Using a suitable tool release clip from harness connector.

△: Clip

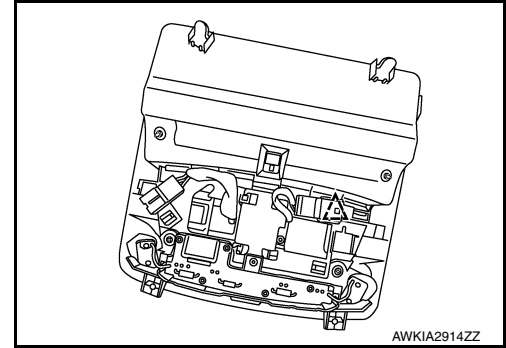

3. Using a suitable tool release pawls and remove moonroof switch finisher (1).

○: Pawl

4. Using a suitable tool release pawls and remove moonroof switch (2) from the front room/map lamp.

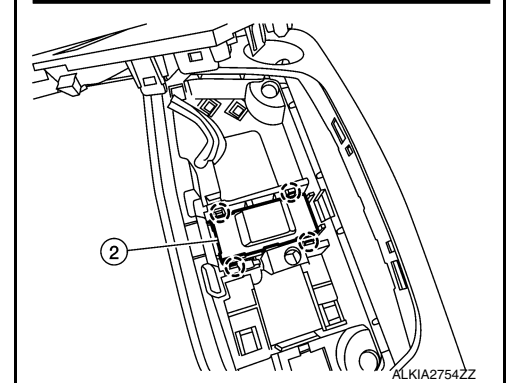
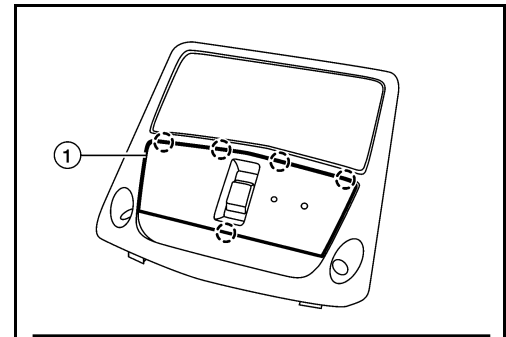

INSTALLATION

Installation is in the reverse order of removal.

SUNSHADE

< UNIT DISASSEMBLY AND ASSEMBLY >

UNIT DISASSEMBLY AND ASSEMBLY

SUNSHADE

Disassembly and Assembly

INFOID:000000012876248

CAUTION:

- Do not rotate sunshade retainer and moonroof unit bases or damage to components may occur.
- Do not over tighten screws on the moonroof unit bases or damage may occur.

DISASSEMBLY

1. Open the sunshade leaving eight inches showing.
2. Remove panoramic roof glass. Refer to [RF-47. "Removal and Installation"](#).
3. Release sunshade retainer (2) from sunshade retainer couplings (1) (LH/RH).
- a. Release the sunshade retainer from both couplings (LH/RH) by pulling rearward as shown.

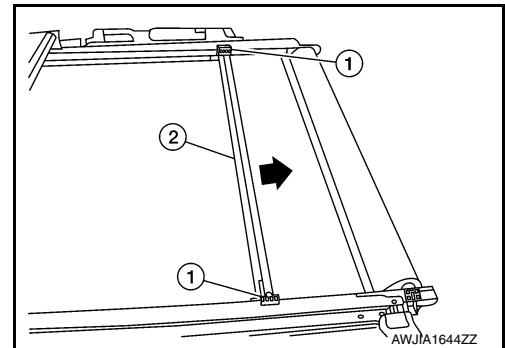

- b. Rotate the sunshade retainer 90 degrees as shown.
- c. Pull back the sunshade retainer (2) to remove ends from each sunshade coupling (1) (LH/RH).

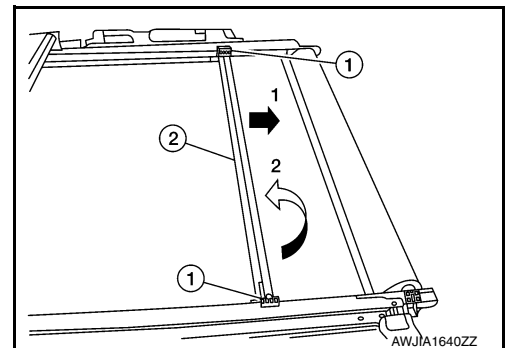

4. Remove sunshade (1) by applying pressure toward the drivers side and pulling rearward from the moonroof bases.
5. Remove moonroof unit base screws (A).
6. Disassemble by pulling off both moonroof unit bases (LH/RH) from the moonroof unit tracks.

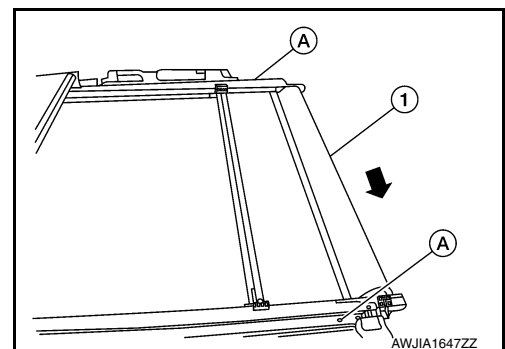

7. Manually disengage the sunshade motor and moonroof motor assembly using a suitable tool then remove both sunshade cables and glass lid cables by pulling rearward.
8. Remove the cable guides (LH/RH) by pulling rearward from the moonroof unit tracks.

ASSEMBLY

CAUTION:

Do not remove the sunshade retainer pin or damage may occur.

1. Insert the sunshade and glass lid cables guides by sliding forward on the moonroof unit track.

A
B
C
D
E
F
G
H
I
J
RF
L
M
N
O
P

SUNSHADE

< UNIT DISASSEMBLY AND ASSEMBLY >

2. Assemble moonroof unit bases (2) (LH/RH) by pushing forward on the moonroof unit tracks (1) (LH/RH).

NOTE:

RH side shown; LH similar.

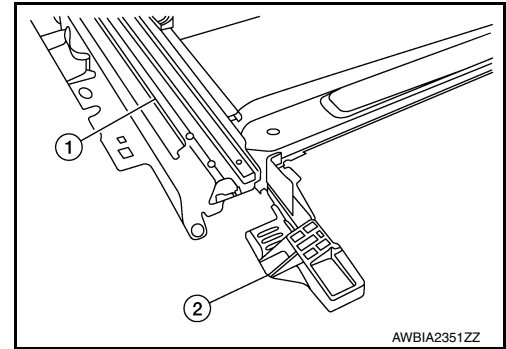

3. Insert sunshade black hem (3) over lower guide (2) and under upper guide (1) on the moonroof unit bases (1) (LH/RH).

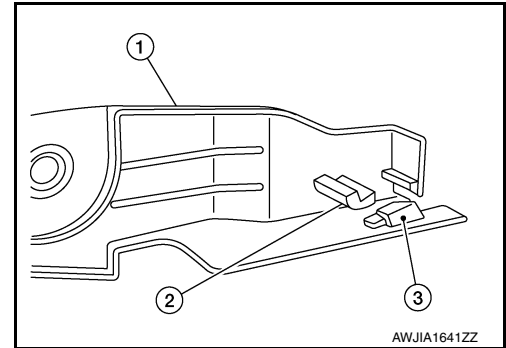

(1) Sunshade black hem.

(2) Sunshade fabric.

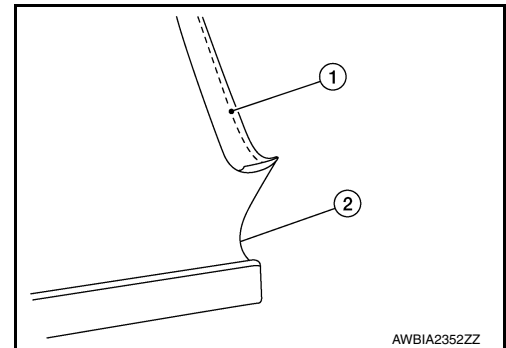

4. Assemble the sunshade by applying pressure towards the drivers and inserting both ends into the moonroof unit bases (LH/RH).
5. Assemble sunshade retainer.
 - a. Position the sunshade retainer on the backside of the moonroof unit couplings then position the moonroof unit couplings inside the sunshade stays open channel.
 - b. Rotate the sunshade 90 degrees.
 - c. Snap in place both ends of the sunshade stay on both LH/RH sunshade couplings.

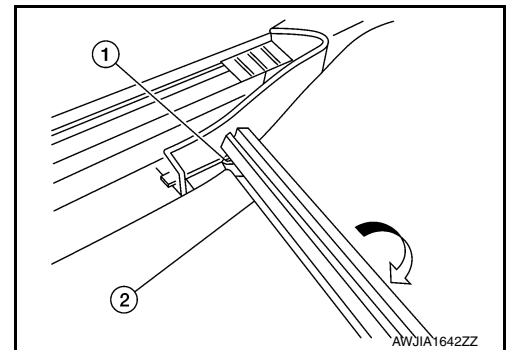

6. Manually engage the sunshade motor and moonroof motor assembly using a suitable tool

SUNSHADE

< UNIT DISASSEMBLY AND ASSEMBLY >

7. With the sunshade (2) assembled remove the sunshade spring retainer pin (1).

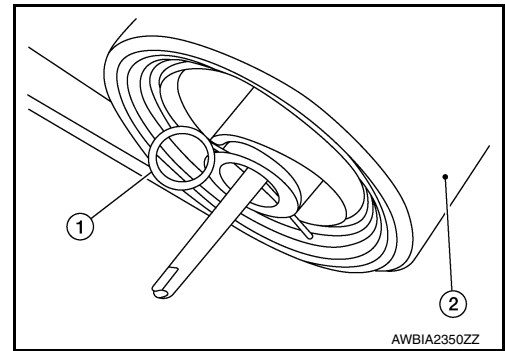

8. Install panoramic roof glass. Refer to [RF-47. "Removal and Installation"](#).
9. Install moonroof unit assembly. Refer to [RF-55. "Removal and Installation"](#).

A
B
C
D
E
F
G
H
I
J
RF
L
M
N
O
P