

SECTION **RSU**
 REAR SUSPENSION

A
B
C
D

RSU

CONTENTS

PRECAUTION	2	Disposal	12	F
PRECAUTIONS	2	RADIUS ROD	13	G
Precaution for Supplemental Restraint System (SRS) "AIR BAG" and "SEAT BELT PRE-TENSIONER"	2	Exploded View	13	
Precautions for Suspension	2	Removal and Installation	13	
PREPARATION	3	FRONT LOWER LINK	14	H
PREPARATION	3	Exploded View	14	
Special Service Tool	3	Removal and Installation	14	
Commercial Service Tool	3	REAR STABILIZER	16	I
SYMPTOM DIAGNOSIS	4	Exploded View	16	
NOISE, VIBRATION AND HARSHNESS (NVH) TROUBLESHOOTING	4	Removal and Installation	16	
NVH Troubleshooting Chart	4	REAR SUSPENSION ARM	18	J
PERIODIC MAINTENANCE	5	Exploded View	18	
REAR SUSPENSION ASSEMBLY	5	Removal and Installation	18	
Inspection	5	UNIT REMOVAL AND INSTALLATION	21	K
REAR WHEEL ALIGNMENT INSPECTION	6	REAR SUSPENSION MEMBER	21	L
Inspection	6	Exploded View	21	
Adjustment	7	Removal and Installation	21	
REMOVAL AND INSTALLATION	9	UNIT DISASSEMBLY AND ASSEMBLY	24	M
REAR LOWER LINK & COIL SPRING	9	REAR SHOCK ABSORBER	24	N
Exploded View	9	Exploded View	24	
Removal and Installation	9	Disassembly and Assembly	24	
REAR SHOCK ABSORBER	11	SERVICE DATA AND SPECIFICATIONS (SDS)	25	O
Exploded View	11	SERVICE DATA AND SPECIFICATIONS (SDS)	25	
Removal and Installation	11	Wheel Alignment (Unladen*)	25	P
		Ball Joint	25	
		Wheelarch Height (Unladen*)	25	

PRECAUTIONS

< PRECAUTION >

PRECAUTION

PRECAUTIONS

Precaution for Supplemental Restraint System (SRS) "AIR BAG" and "SEAT BELT PRE-TENSIONER"

INFOID:000000012894923

The Supplemental Restraint System such as "AIR BAG" and "SEAT BELT PRE-TENSIONER", used along with a front seat belt, helps to reduce the risk or severity of injury to the driver and front passenger for certain types of collision. Information necessary to service the system safely is included in the SR and SB section of this Service Manual.

WARNING:

- To avoid rendering the SRS inoperative, which could increase the risk of personal injury or death in the event of a collision which would result in air bag inflation, it is recommended that all maintenance and repair be performed by an authorized NISSAN/INFINITI dealer.
- Improper repair, including incorrect removal and installation of the SRS, can lead to personal injury caused by unintentional activation of the system. For removal of Spiral Cable and Air Bag Module, see the SR section.
- Do not use electrical test equipment on any circuit related to the SRS unless instructed to in this Service Manual. SRS wiring harnesses can be identified by yellow and/or orange harnesses or harness connectors.

PRECAUTIONS WHEN USING POWER TOOLS (AIR OR ELECTRIC) AND HAMMERS

WARNING:

- When working near the Air Bag Diagnosis Sensor Unit or other Air Bag System sensors with the Ignition ON or engine running, DO NOT use air or electric power tools or strike near the sensor(s) with a hammer. Heavy vibration could activate the sensor(s) and deploy the air bag(s), possibly causing serious injury.
- When using air or electric power tools or hammers, always switch the Ignition OFF, disconnect the battery or batteries, and wait at least three minutes before performing any service.

Precautions for Suspension

INFOID:000000012894924

- When installing rubber bushings, the final tightening must be carried out under unladen conditions with tires on ground. Spilled oil might shorten the life of rubber bushings. Be sure to wipe off any spilled oil.
- Unladen conditions mean that fuel, engine coolant and lubricants are full. Spare tire, jack, hand tools and mats are in designated positions.
- After servicing suspension parts, be sure to check wheel alignment.
- Self-lock nuts are not reusable. Always use new ones when installing. Since new self-lock nuts are pre-oiled, tighten as they are.
- The tightening surface must be kept free of oil/grease.
- When jacking up the vehicle with a floor jack, do not hang the jack on the front lower link.

PREPARATION

< PREPARATION >

PREPARATION

PREPARATION

Special Service Tool

INFOID:0000000012894925

The actual shape of the tools may differ from those illustrated here.

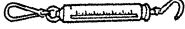
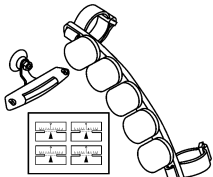
Tool number (TechMate No.) Tool name	Description
— (J-44372) Pull gauge  LST024	Measuring ball joint swinging force
— (J-49286) Drift and Pull gauge  AWEIA0156ZZ	Measuring drift and pull

Commercial Service Tool

INFOID:0000000012894926

Tool name	Description
Power tool  PIIB1407E	Loosening nuts, screws and bolts

A
B
C
D
RSU
F
G
H
I
J
K
L
M
N
O
P

NOISE, VIBRATION AND HARSHNESS (NVH) TROUBLESHOOTING

< SYMPTOM DIAGNOSIS >

SYMPTOM DIAGNOSIS

NOISE, VIBRATION AND HARSHNESS (NVH) TROUBLESHOOTING

NVH Troubleshooting Chart

INFOID:0000000012894927

Use chart below to find the cause of the symptom. If necessary, repair or replace these parts.

Symptom		Possible cause and SUSPECTED PARTS		Reference page													
				RSU-5, RSU-9, RSU-11, RSU-13, RSU-14, RSU-16, RSU-18	RSU-5	—	—	—	RSU-5, RSU-9, RSU-11, RSU-13, RSU-14, RSU-16, RSU-18	RSU-6	RSU-5	DLN-87	DLN-102	RAX-5	WT-61	WT-61	RAX-5
Noise	REAR SUSPENSION	Improper installation, looseness	Shock absorber deformation, damage or deflection	Bushing or mounting deterioration	Parts interference	Spring fatigue	Suspension looseness	Incorrect wheel alignment	Stabilizer fatigue	PROPELLER SHAFT (AWD)	DIFFERENTIAL (AWD)	REAR AXLE	TIRE	WHEEL	DRIVE SHAFT (AWD)	BRAKE	
		×	×	×	×	×	×			×	×	×	×	×	×	×	
		×	×	×	×		×				×		×	×	×	×	×
		×	×	×	×	×			×				×	×	×		×
		×	×	×									×	×	×		×
		×	×	×	×	×			×	×				×	×	×	

×: Applicable

REAR SUSPENSION ASSEMBLY

< PERIODIC MAINTENANCE >

PERIODIC MAINTENANCE

REAR SUSPENSION ASSEMBLY

Inspection

INFOID:0000000012894928

ON-VEHICLE SERVICE

- Check the suspension parts for excessive play, cracks, wear or damage. Shake each rear wheel to check for excessive play.
- Retighten all nuts and bolts to the specified torque.
- Check the wheelarch height. Refer to [RSU-25. "Wheelarch Height \(Unladen*\)"](#).

SHOCK ABSORBER

- Check for smooth operation through a full stroke for both compression and extension.
- Check for oil leaks on the welded or gland packing portions.
- Check the shock absorber piston rod for cracks, deformation or other damage and replace if necessary.

SUSPENSION ARM

- Check the suspension arm for damage, cracks, deformation and replace if necessary.
- Check the rubber bushings for damage, cracks and deformation. Replace suspension arm if necessary.
- Make sure that each cotter pin is installed (if equipped).
- Check the suspension ball joint for grease leaks and the ball joint dust cover for cracks or other damage.
- Check the ball joint. Replace the suspension arm if the ball stud is worn or the joint is hard to swing.

RADIUS ROD

- Check the radius rod for any deformation, cracks, or damage and replace if necessary.
- After installing the radius rod, check the wheel alignment and adjust if necessary. Refer to [RSU-25. "Wheel Alignment \(Unladen*\)"](#).

FRONT LOWER LINK

Check the front lower link for any deformation, cracks, or damage and replace if necessary.

UPPER AND LOWER RUBBER SEATS

Check the upper and lower rubber seats for deterioration or cracks and replace if necessary.

REAR LOWER LINK AND COIL SPRING

Check the rear lower link and coil spring for any deformation, cracks, or other damage and replace if necessary.

REAR STABILIZER

- Check the rear stabilizer and clamps for any deformation, cracks or damage and replace if necessary.
- Check the rubber bushings for deterioration or cracks and replace if necessary.

A

B

C

D

RSU

F

G

H

I

J

K

L

M

N

O

P

REAR WHEEL ALIGNMENT INSPECTION

< PERIODIC MAINTENANCE >

REAR WHEEL ALIGNMENT INSPECTION

Inspection

INFOID:000000012894929

PRELIMINARY INSPECTION

WARNING:

Always adjust wheel alignment with vehicle on flat surface.

NOTE:

If the wheel alignment is out of specification, inspect and replace any damaged or worn suspension parts before making any adjustments.

Check the following:

- Check and adjust the wheel alignment with the vehicle under unladen conditions. "Unladen conditions" means that the fuel, engine coolant, and lubricants are full; spare tire, jack, hand tools and mats are in designated positions.
- Check the tires for incorrect air pressure and for excessive wear. Refer to [WT-72, "Tire Air Pressure"](#).
- Check the wheels for deformation, cracks, and other damage. Remove the wheel and check the wheel runout. Refer to [WT-62, "Inspection"](#).
- Check the rear wheel bearings for looseness.
- Check the rear suspension for looseness.
- Check that the rear shock absorbers work properly.
- Check the wheelarch height in the unladen conditions. Refer to [RSU-25, "Wheelarch Height \(Unladen*\)"](#).

GENERAL INFORMATION AND RECOMMENDATIONS

1. A Four-Wheel Thrust Alignment should be performed.
 - This type of alignment is recommended for any NISSAN/INFINITI vehicle.
 - The four-wheel "thrust" process helps ensure that the vehicle is properly aligned and the steering wheel is centered.
 - The alignment machine itself should be capable of accepting any NISSAN/INFINITI vehicle.
 - The alignment machine should be checked to ensure that it is level.
2. Make sure the alignment machine is properly calibrated.
 - Your alignment machine should be regularly calibrated in order to give correct information.
 - Check with the manufacturer of your specific alignment machine for their recommended Service/Calibration Schedule.

THE ALIGNMENT PROCESS

CAUTION:

If the vehicle is equipped with the Intelligent Cruise Control (ICC) system and the rear toe has been adjusted during a wheel alignment, the ICC sensor must be aligned. Refer to [CCS-64, "ICC Sensor Adjustment"](#).

IMPORTANT: Use only the alignment specifications listed in this Service Manual. Refer to [RSU-25, "Wheelarch Height \(Unladen*\)"](#).

1. When displaying the alignment settings, many alignment machines use "indicators": (Green/red, plus or minus, Go/No Go). **Do NOT use these indicators.**
 - The alignment specifications programmed into your alignment machine that operate these indicators may not be correct.
 - This may result in an ERROR.
2. Most camera-type alignment machines are equipped with both a "Rolling Compensation" method and an optional "Jacking Compensation" method to compensate the alignment targets or head units. "Rolling Compensation" is the preferred method.

"Rolling Compensation" is the preferred method.

 - If using the "Rolling Compensation" method, after installing the alignment targets or head units, push or pull on the rear wheel to move the vehicle. **Do not push or pull on the vehicle body.**
 - If using the "Jacking Compensation" method, after installing the alignment targets or head units, raise the vehicle and rotate the wheels 1/2 turn both ways.

NOTE:

- Do not use the "Rolling Compensation" method if you are using sensor-type alignment equipment.
- Follow all instructions for the alignment machine you're using for more information.

REAR WHEEL ALIGNMENT INSPECTION

< PERIODIC MAINTENANCE >

INFOID:000000012894930

Adjustment

CAMBER

1. Measure the camber of both the right and left wheels using a suitable alignment gauge and adjust using the following procedure.

Camber : Refer to [RSU-25, "Wheel Alignment \(Unladen*\)"](#).

If the camber is not within specification, inspect and replace any damaged or worn rear suspension parts before adjusting.

2. Turn the adjusting bolts in the same direction to calibrate.

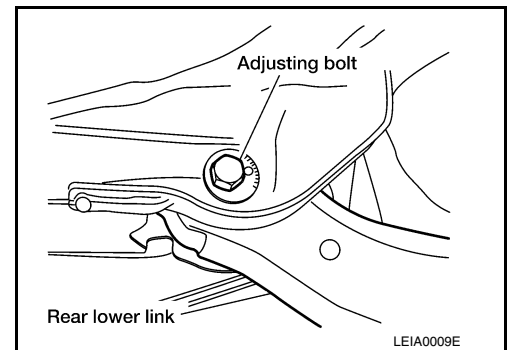
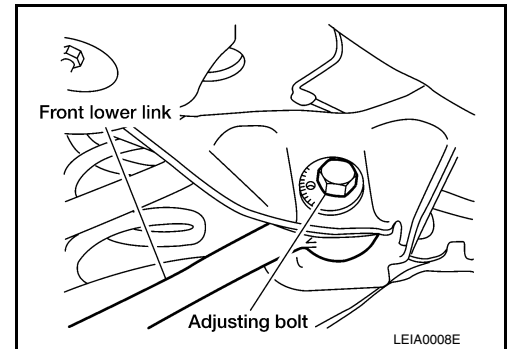

3. Tighten the adjusting bolt nuts to the specified torque.

Adjusting bolt nuts : Refer to [RSU-9, "Exploded View"](#) and [RSU-14, "Exploded View"](#).

CAUTION:

- When tightening the nut firmly and checking the torque, use a wrench to prevent the turning of the bolt.
- After adjusting camber, be sure to check toe-in.

TOE-IN

1. Measure the toe-in of the rear wheels. If out of specification, inspect and replace any damaged or worn rear suspension parts before adjusting.

Total toe-in : Refer to [RSU-25, "Wheel Alignment \(Unladen*\)"](#).

REAR WHEEL ALIGNMENT INSPECTION

< PERIODIC MAINTENANCE >

2. Adjust toe-in by turning adjusting bolt on rear lower link.
3. After adjusting, tighten the adjusting bolt nut to the specified torque.

Adjusting bolt nut : Refer to [RSU-9, "Exploded View"](#).

CAUTION:

When tightening the nut firmly and checking the torque, use a wrench to prevent the turning of the bolt.

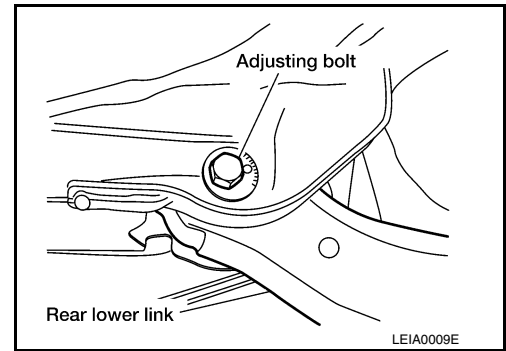

4. After adjusting alignment it is necessary to adjust the neutral position of the steering angle sensor. Refer to [BRC-62, "Description"](#).

CAUTION:

If the vehicle is equipped with the Intelligent Cruise Control (ICC) system and the rear toe has been adjusted during a wheel alignment, the ICC sensor must be aligned. Refer to [CCS-64, "ICC Sensor Adjustment"](#).

REAR LOWER LINK & COIL SPRING

< REMOVAL AND INSTALLATION >

REMOVAL AND INSTALLATION

REAR LOWER LINK & COIL SPRING

Exploded View

INFOID:0000000012894931

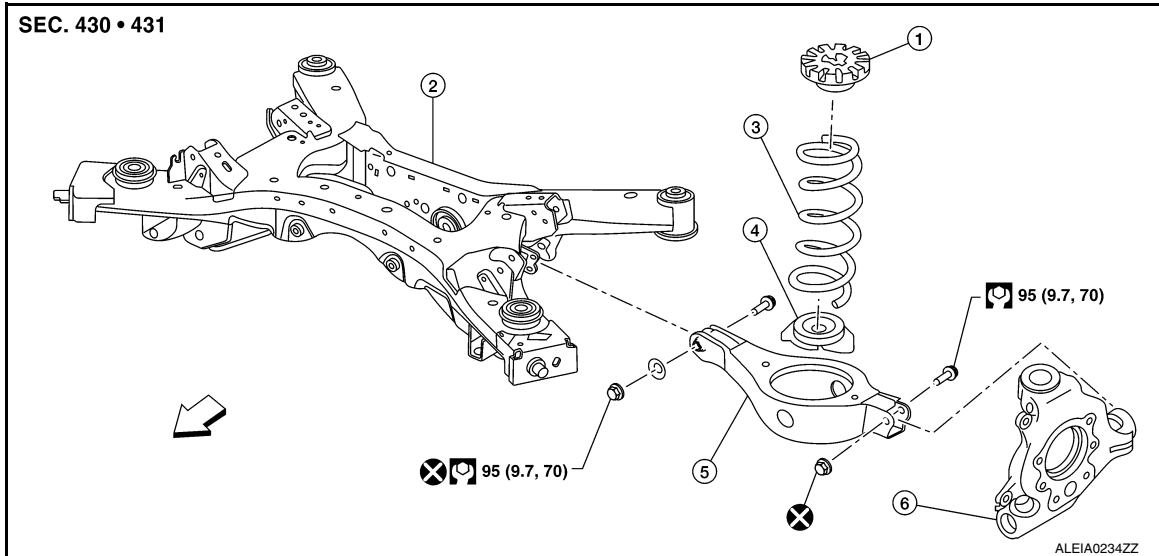

- | | | |
|----------------------|---------------------------|-----------------|
| 1. Upper seat | 2. Rear suspension member | 3. Coil spring |
| 4. Lower rubber seat | 5. Rear lower link | 6. Rear knuckle |
- ⇐ Front

Removal and Installation

INFOID:0000000012894932

REMOVAL

1. Remove the front undercover. Refer to [EXT-40. "FRONT UNDER COVER : Removal and Installation"](#).
2. Support the front of vehicle with a suitable jack.

WARNING:

Place a suitable jack under the center of the front suspension member.

CAUTION:

Do not damage the front suspension member with the suitable jack.

3. Remove the rear wheel and tire using power tool. Refer to [WT-66. "Removal and Installation"](#).
4. Put alignment marks on the adjusting bolt and on the rear lower link.

CAUTION:

Use paint or an equivalent for alignment marks. Do not scratch the surface.

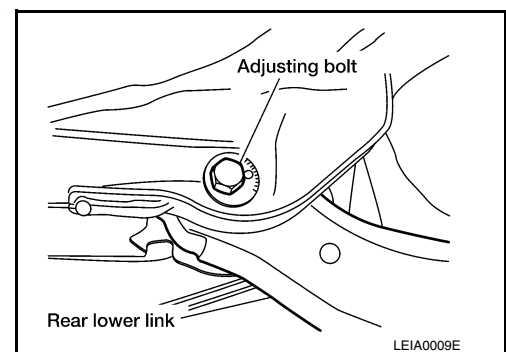

5. Loosen the rear lower link adjusting bolt on the rear suspension member.
6. Support the rear lower link with a suitable jack.

WARNING:

Place a suitable jack under the outer end of the rear lower link.

CAUTION:

REAR LOWER LINK & COIL SPRING

< REMOVAL AND INSTALLATION >

Do not damage the rear lower link with the suitable jack.

7. Support the rear knuckle with a suitable jack.

WARNING:

Place a suitable jack under the center of the rear knuckle.

CAUTION:

Do not damage the rear knuckle with the suitable jack.

8. Remove the rear lower link nut and bolt from the rear knuckle using power tool.
9. Slowly lower the suitable jack supporting the rear lower link. Remove the upper seat, the coil spring, and the lower rubber seat from the rear lower link.
10. Remove the rear lower link nut and bolt from the rear suspension member using power tool.
11. Remove the rear lower link.

INSTALLATION

Installation is in the reverse order of removal.

CAUTION:

Do not reuse lower link nuts.

- Make sure that the upper seat is attached as shown.

CAUTION:

- **Keep the upper seat (1) in place during coil spring installation. The protrusion (A) on the upper seat faces the outside of the vehicle.**
- **Align the tabs (C) to the upper seat openings and securely fit the bracket (2) to the tabs (B).**

⇐ : Body

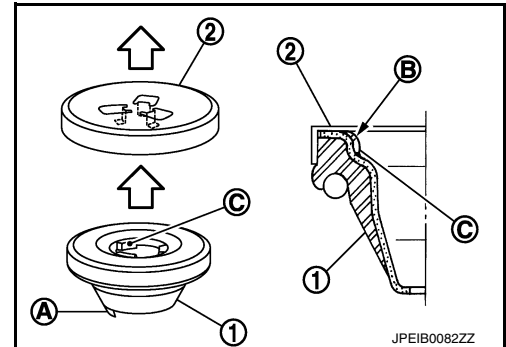

- Perform the final tightening of the parts under unladen conditions with the tires on level ground.
- Check the wheel alignment. Refer to [RSU-6. "Inspection"](#).
- Adjust the neutral position of the steering angle sensor. Refer to [BRC-62. "Description"](#).

REAR SHOCK ABSORBER

< REMOVAL AND INSTALLATION >

REAR SHOCK ABSORBER

Exploded View

INFOID:000000012894933

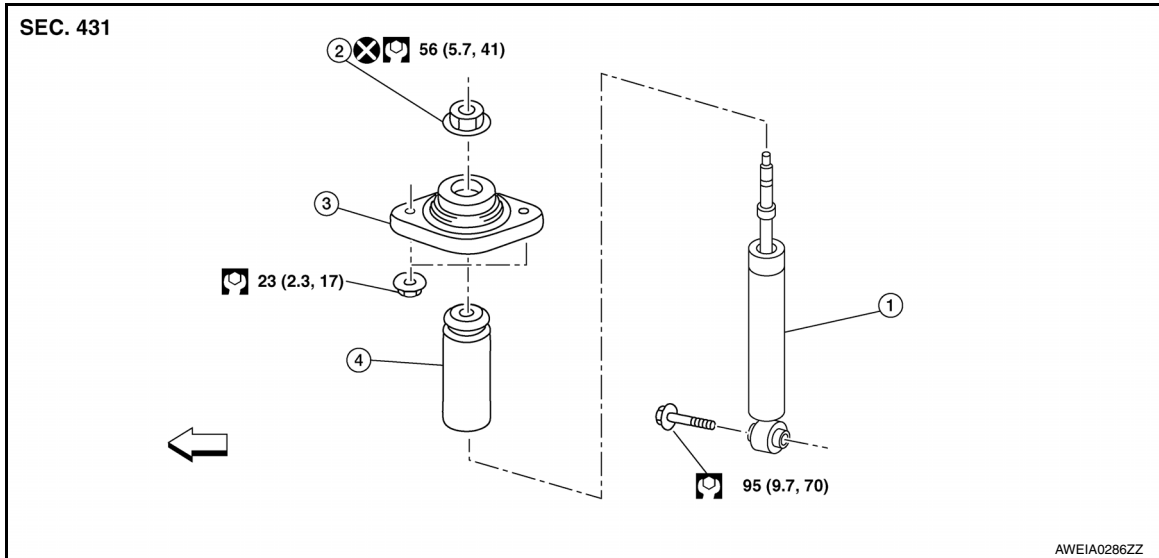

- 1. Rear shock absorber
 - 2. Piston rod lock nut
 - 3. Shock absorber insulator
 - 4. Bound bumper
- ⇐ Front

Removal and Installation

INFOID:000000012894934

REMOVAL

1. Remove the rear wheel and tire using power tool. Refer to [WT-66. "Removal and Installation"](#).
2. Set a suitable jack under the rear lower link to relieve the coil spring tension.

WARNING:

Place a suitable jack under the outer end of the rear lower link.

CAUTION:

Do not damage the rear lower link with the suitable jack.

3. Remove the lower rear shock absorber bolt (A) using power tool.

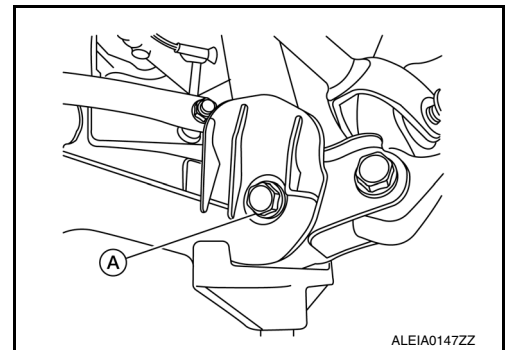

4. Gradually lower the suitable jack to separate the rear shock absorber from the rear lower link.

REAR SHOCK ABSORBER

< REMOVAL AND INSTALLATION >

5. Remove the rear shock absorber nuts (←).

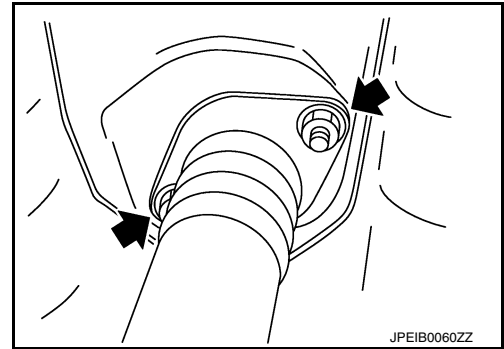

6. Remove the rear shock absorber.

INSTALLATION

Installation is in the reverse order of removal.

- Perform the final tightening of the parts under unladen conditions with the tires on level ground.

Disposal

INFOID:000000012894935

1. Set the shock absorber horizontally with the piston rod fully extended.
2. Drill a 2 – 3 mm (0.08 – 0.12 in) hole at the position (●) as shown to release gas gradually.

CAUTION:

- Wear eye protection (safety glasses).
- Wear gloves.
- Be careful with metal chips or oil blown out by the compressed gas.

NOTE:

- Drill vertically in this direction (←) directly into the outer tube avoiding brackets.
- The gas is clear, colorless, odorless, and harmless.

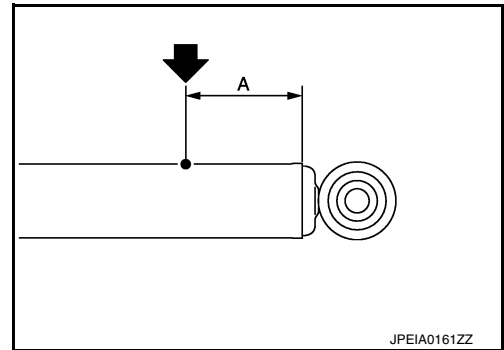

(A) : 20 – 30 mm (0.79 – 1.18 in)

3. Position the drilled hole downward and drain the oil by moving the piston rod several times.

CAUTION:

Dispose of drained oil according to the law and local regulations.

RADIUS ROD

< REMOVAL AND INSTALLATION >

RADIUS ROD

Exploded View

INFOID:000000012894936

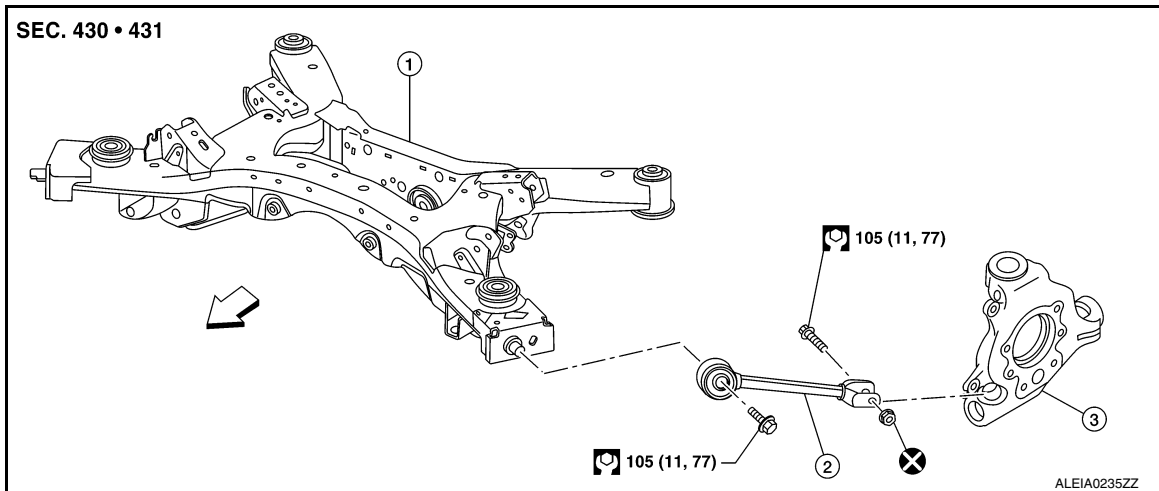

1. Rear suspension member

2. Radius rod

3. Rear knuckle

⇐ Front

Removal and Installation

INFOID:000000012894937

REMOVAL

1. Remove the rear wheel and tire using power tool. Refer to [WT-66, "Removal and Installation"](#).
2. Support the rear knuckle with a suitable jack.

WARNING:

Place a suitable jack under the rear knuckle.

CAUTION:

Do not damage the rear knuckle with the suitable jack.

3. Remove the radius rod nut and bolt from the rear knuckle using power tool.
4. Remove the radius rod bolt from the rear suspension member using power tool.
5. Remove the radius rod.

INSTALLATION

Installation is in the reverse order of removal.

CAUTION:

Do not reuse the radius rod nut.

Perform the final tightening of the parts under unladen conditions with the tires on level ground.

FRONT LOWER LINK

< REMOVAL AND INSTALLATION >

FRONT LOWER LINK

Exploded View

INFOID:000000012894938

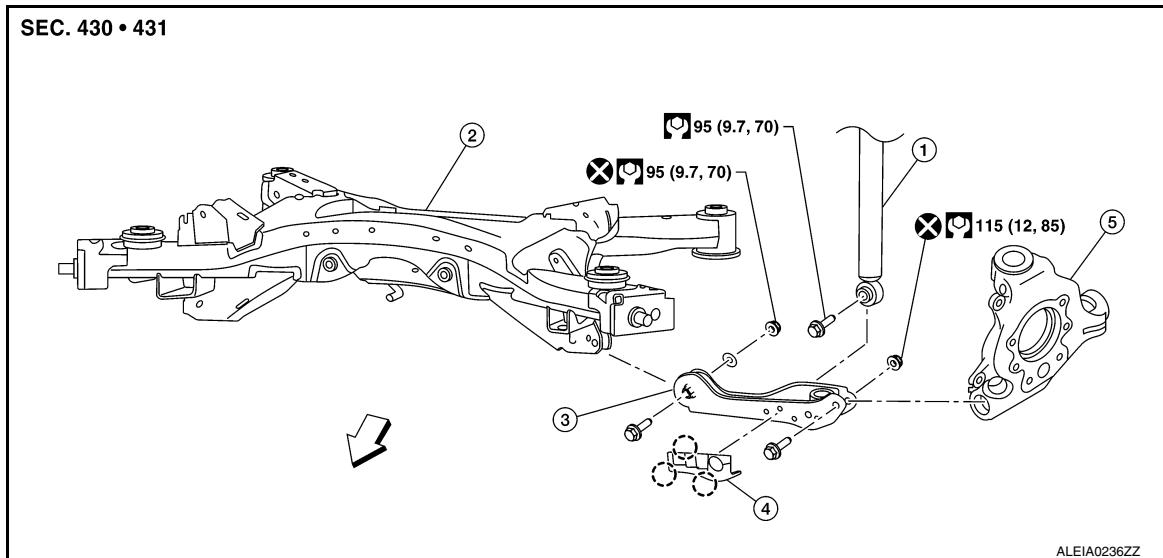

- | | | |
|-----------------------------------|---------------------------|---------------------|
| 1. Rear shock absorber | 2. Rear suspension member | 3. Front lower link |
| 4. Rear suspension link protector | 5. Rear knuckle | ○ Pawl |

← Front

Removal and Installation

INFOID:000000012894939

REMOVAL

1. Remove the front under cover. Refer to [EXT-40. "FRONT UNDER COVER : Removal and Installation"](#).
2. Support the front of vehicle with a suitable jack.

WARNING:

Place a suitable jack under the center of the front suspension member.

CAUTION:

Do not damage the front suspension member with the suitable jack.

3. Remove the rear wheel and tire using power tool. Refer to [WT-66. "Removal and Installation"](#).
4. Support the rear lower link with a suitable jack.

WARNING:

Place a suitable jack under the outer end of the rear lower link.

CAUTION:

Do not damage the rear lower link with the suitable jack.

5. Support the rear knuckle with a suitable jack.

WARNING:

Place a suitable jack under the center of the rear knuckle.

CAUTION:

Do not damage the rear knuckle with the suitable jack.

FRONT LOWER LINK

< REMOVAL AND INSTALLATION >

- Put alignment marks on the adjusting bolt and on the rear suspension member.

CAUTION:

Use paint or an equivalent for alignment marks. Do not scratch the surface.

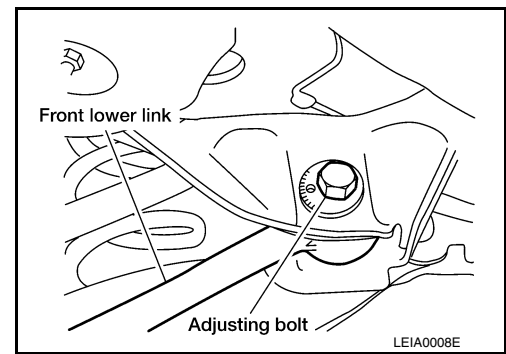

- Remove the lower shock absorber bolt using power tool. Refer to [RSU-11, "Exploded View"](#).
- Support the rear lower link with a suitable jack.
WARNING:
Place a suitable jack under the outer end of the rear lower link.
CAUTION:
Do not damage the rear lower link with the suitable jack.
- Remove the rear lower link nut and bolt from the rear knuckle using power tool. Refer to [RSU-9, "Exploded View"](#).
- Slowly lower the suitable jack supporting the rear lower link. Remove the upper seat, the coil spring, and the lower rubber seat from the rear lower link. Refer to [RSU-9, "Exploded View"](#).
- Remove the coil spring. Refer to [RSU-9, "Exploded View"](#).
- Remove the front lower link nut and bolt from the rear suspension member using power tool.
- Remove the front lower link nut and bolt from the rear knuckle using power tool.
- Remove the rear suspension link protector by pulling forward and releasing pawls.
- Remove the front lower link.

INSTALLATION

Installation is in the reverse order of removal.

CAUTION:

Do not reuse the front lower link nuts.

- Perform the final tightening of the parts under unladen conditions with the tires on level ground.
- Check the wheel alignment. Refer to [RSU-6, "Inspection"](#).
- Adjust the neutral position of the steering angle sensor. Refer to [BRC-62, "Description"](#).

A
B
C
D
RSU
F
G
H
I
J
K
L
M
N
O
P

REAR STABILIZER

< REMOVAL AND INSTALLATION >

REAR STABILIZER

Exploded View

INFOID:000000012894940

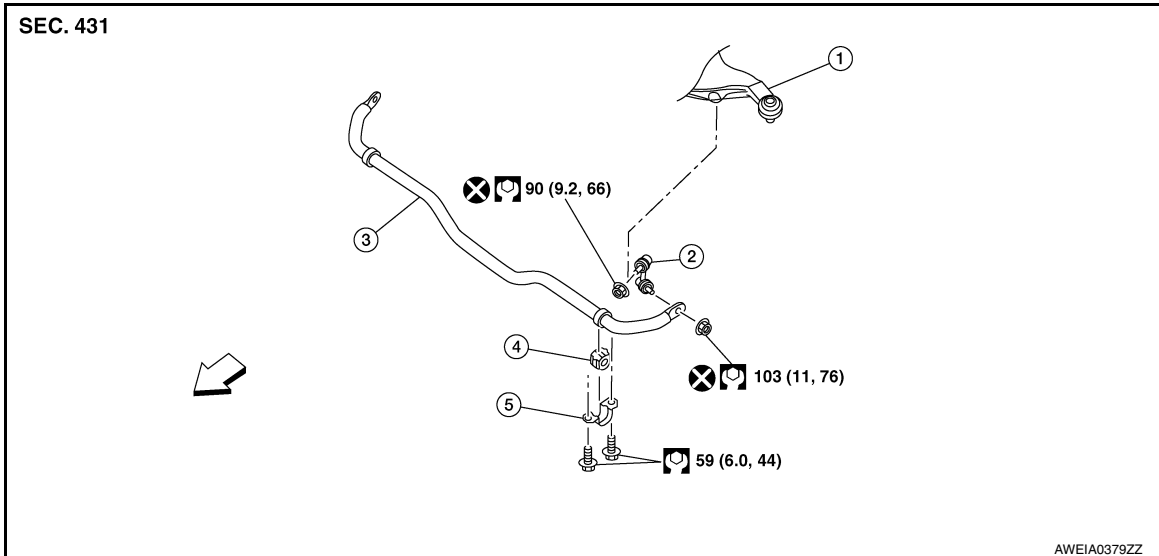

- | | | |
|------------------------|------------------------------|---------------|
| 1. Rear suspension arm | 2. Stabilizer connecting rod | 3. Stabilizer |
| 4. Stabilizer bushing | 5. Stabilizer clamp | ⇐ Front |

Removal and Installation

INFOID:000000012894941

REMOVAL

1. Remove the rear under covers (LH/RH). Refer to [EXT-40, "REAR UNDER COVER : Removal and Installation"](#).
2. Separate center exhaust tube from muffler. Refer to [EX-5, "Exploded View"](#).
3. Remove center exhaust tube from rear mounting rubber. Refer to [EX-5, "Exploded View"](#).
4. Apply matching marks to the rear suspension arms, the stabilizer connecting rods, and the stabilizer to identify the installation position (LH/RH).

CAUTION:

Use paint or an equivalent for matching marks. Do not scratch the surface.

5. Remove the upper stabilizer connecting rod nuts (A). Separate the stabilizer connecting rods from the rear suspension arms (LH/RH).

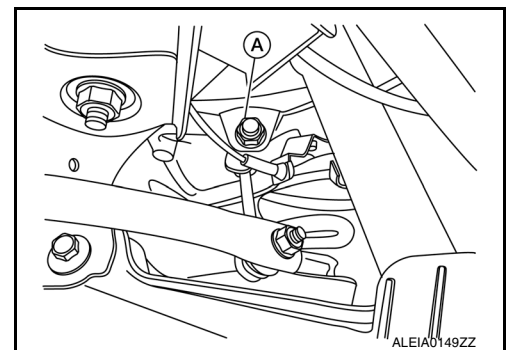

REAR STABILIZER

< REMOVAL AND INSTALLATION >

6. Remove the stabilizer clamp bolts (A) using power tool (LH/RH).

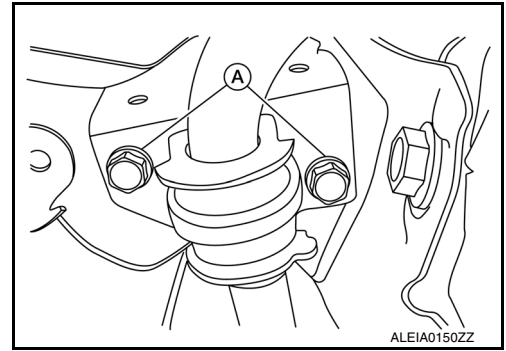

7. Remove the stabilizer clamps (LH/RH).
8. Remove the stabilizer bushings (LH/RH).
9. Remove the stabilizer.
10. Remove the lower stabilizer connecting rod nuts. Separate the stabilizer connecting rods from the stabilizer (LH/RH).

INSTALLATION

Installation is in the reverse order of removal.

CAUTION:

Do not reuse stabilizer connecting rod nuts.

- Position the stabilizer bushings with the slit facing the front of the vehicle.
- Align the matching marks when installing.
- Tighten the stabilizer connecting rod nut to the specified torque while holding the hexagonal part of the stabilizer connecting rod stud.
- Perform the final tightening of the parts under unladen conditions with the tires on level ground.

A
B
C
D

RSU

F
G
H
I
J
K
L
M
N
O
P

REAR SUSPENSION ARM

< REMOVAL AND INSTALLATION >

REAR SUSPENSION ARM

Exploded View

INFOID:000000012894942

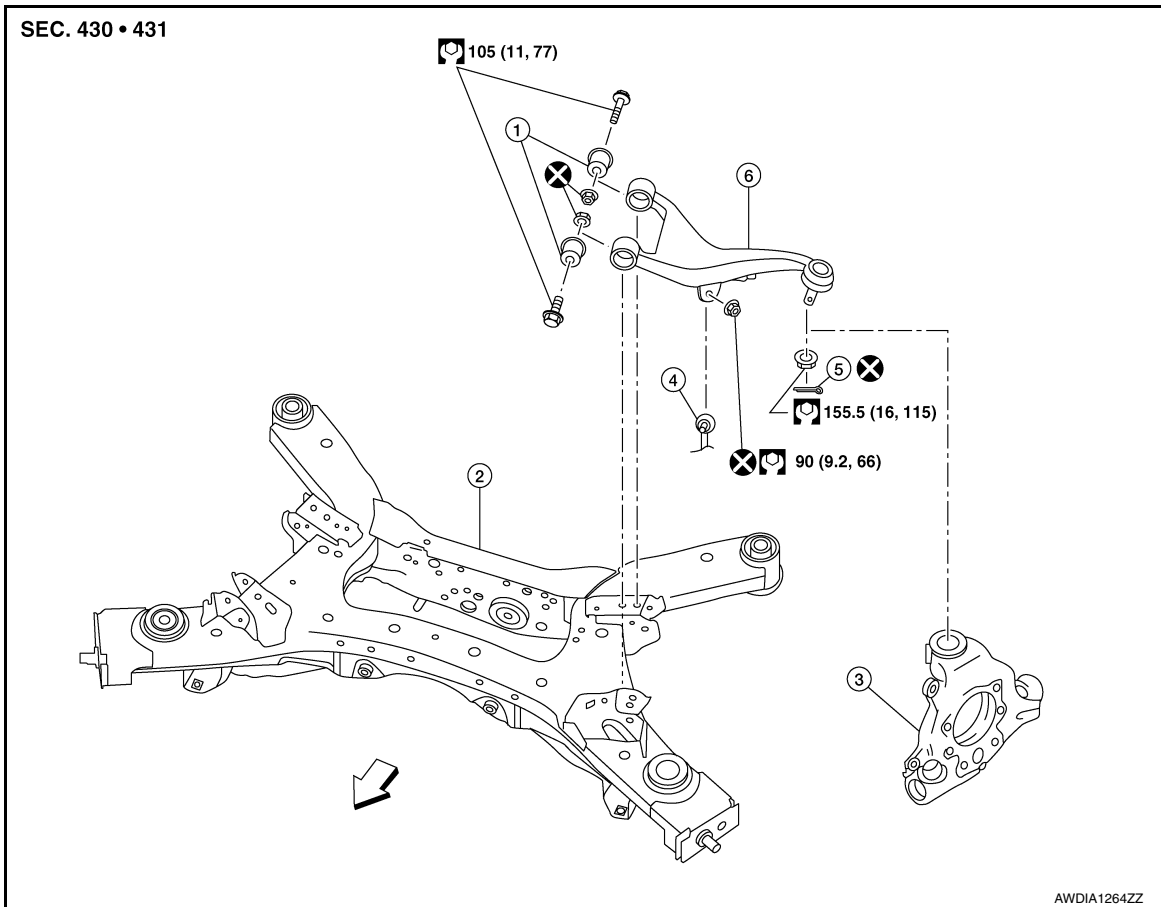

- | | | |
|--------------------------------|---------------------------|------------------------|
| 1. Rear suspension arm bushing | 2. Rear suspension member | 3. Rear knuckle |
| 4. Stabilizer connecting rod | 5. Cotter pin | 6. Rear suspension arm |
- ⇐ Front

Removal and Installation

INFOID:000000012894943

REMOVAL

1. Remove the rear wheel and tire using power tool. Refer to [WT-66. "Removal and Installation"](#).
2. Support the rear lower link with a suitable jack.

WARNING:

Place a suitable jack under the outer end of the rear lower link.

CAUTION:

Do not damage the rear lower link with the suitable jack.

REAR SUSPENSION ARM

< REMOVAL AND INSTALLATION >

3. Remove bolt (1) and separate the rear wheel sensor from the knuckle. Refer to [BRC-168, "REAR WHEEL SENSOR : Exploded View"](#).

CAUTION:

- Pull out the rear wheel sensor being careful to turn it as little as possible. Do not pull on the wheel sensor harness.
- Failure to remove the rear wheel sensor from the rear knuckle may result in damage to the rear wheel sensor.

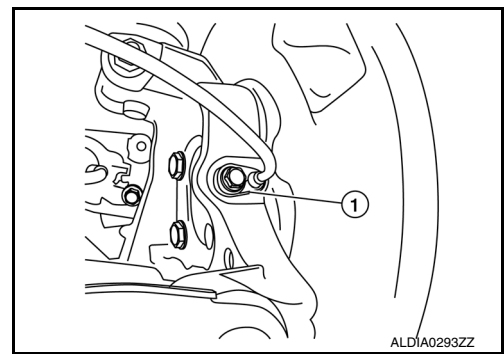

4. For AWD vehicles, remove the rear drive shaft. Refer to [RAX-11, "Removal and Installation"](#).
5. Remove the stabilizer. Refer to [RSU-16, "Removal and Installation"](#).
6. Remove the cotter pin from the rear suspension arm stud.
7. Remove the rear suspension arm nut from the rear knuckle using power tool. Separate the rear suspension arm from the rear knuckle.
8. Remove the rear suspension arm nuts and bolts from the rear suspension member using power tool.
9. Remove the rear suspension arm.
10. If necessary, remove the rear suspension arm bushings.

INSPECTION AFTER REMOVAL

Ball Joint Inspection

Manually move ball joint to confirm it moves smoothly with no binding.

Swinging Torque Inspection

1. Move ball joint at least ten times by hand to check for smooth movement.
2. Hook Tool (A) on ball joint at pinch bolt location. Confirm measurement value is within specifications when ball joint begins moving.

Tool number : - (J-44372)

Swinging torque : Refer to [RSU-25, "Ball Joint"](#).

- If swinging torque exceeds standard range, replace transverse link.

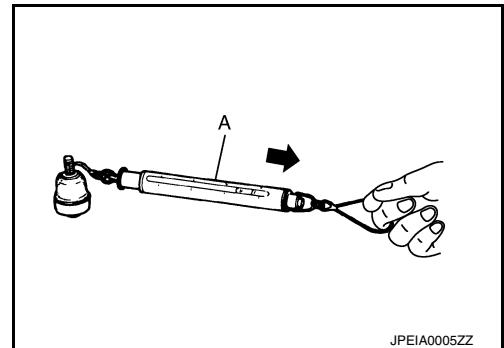

Rotating Torque Inspection

1. Move ball joint at least ten times by hand to check for smooth movement.
2. Confirm measurement value is within specifications when ball joint begins rotating.

Rotating torque : Refer to [RSU-25, "Ball Joint"](#).

- If rotating torque exceeds standard range, replace transverse link.

Axial End Play Inspection

1. Move ball joint at least ten times by hand to check for smooth movement.
2. Move tip of ball joint in axial direction to check for looseness.

Axial end play : Refer to [RSU-25, "Ball Joint"](#).

- If axial end play exceeds standard value, replace transverse link.

INSTALLATION

Installation is in the reverse order of removal.

CAUTION:

- Do not reuse the rear suspension arm nuts at the rear suspension member.
- Do not reuse the cotter pin.

REAR SUSPENSION ARM

< REMOVAL AND INSTALLATION >

- Install the rear wheel sensor to the rear knuckle. Refer to [BRC-169, "REAR WHEEL SENSOR : Removal and Installation"](#).

CAUTION:

- **Before installing, make sure there is no foreign material, such as iron fragments, adhered to the pick-up part of the rear wheel sensor.**
- **When installing, make sure there is no foreign material, such as iron fragments, on and in the hole in the rear knuckle for the rear wheel sensor. Make sure no foreign material has been caught in the sensor rotor. Remove any foreign material and clean the mount.**
- Perform the final tightening of the parts under unladen conditions with tires on level ground.
- Check the wheel alignment. Refer to [RSU-6, "Inspection"](#).
- Adjust the neutral position of the steering angle sensor. Refer to [BRC-62, "Description"](#).
- For AWD vehicles, check the rear differential gear oil level. Refer to [DLN-103, "Inspection"](#).

REAR SUSPENSION MEMBER

< UNIT REMOVAL AND INSTALLATION >

UNIT REMOVAL AND INSTALLATION

REAR SUSPENSION MEMBER

Exploded View

INFOID:0000000012894944

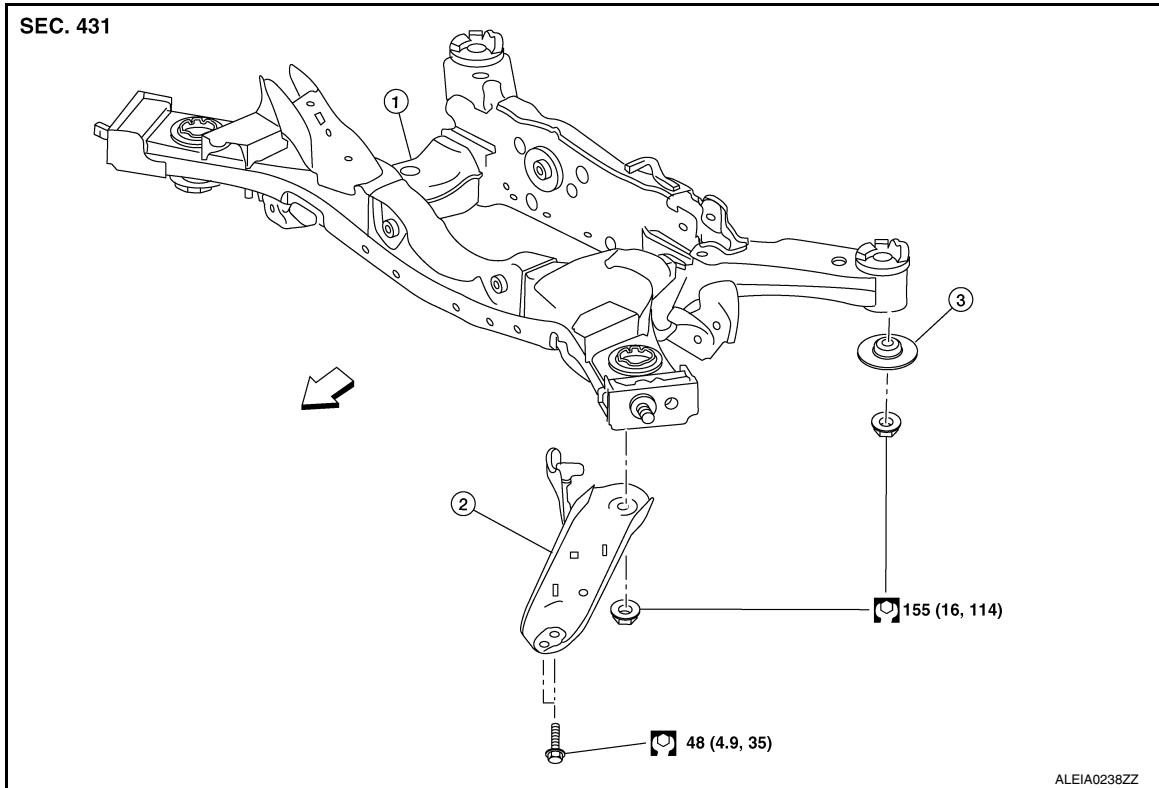

1. Rear suspension member
 2. Rear suspension member stay
 3. Rear suspension member stopper
- ⇐ Front

Removal and Installation

INFOID:0000000012894945

REMOVAL

1. Remove the front under cover. Refer to [EXT-40, "FRONT UNDER COVER : Removal and Installation"](#).
2. Support the front of vehicle with a suitable jack.
WARNING:
Place a suitable jack under the center of the front suspension member.
CAUTION:
Do not damage the front suspension member with the suitable jack.
3. Remove the disc brake rotors (LH/RH). Refer to [BR-45, "DISC BRAKE ROTOR : Removal and Installation"](#).
4. Disconnect the harness connector from the rear wheel sensor harness.
5. Separate the harness from the rear suspension member.
6. Separate the harness from the rear suspension arms (LH/RH).
7. Remove the center exhaust tube. Refer to [EX-5, "Exploded View"](#).
8. For AWD vehicles, remove the propeller shaft. Refer to [DLN-89, "Removal and Installation"](#).
9. For AWD vehicles, remove the rear final drive. Refer to [DLN-116, "Removal and Installation"](#).
10. Remove the stabilizer. Refer to [RSU-16, "Removal and Installation"](#).
11. Separate the parking brake cables from the rear knuckles, from the vehicle chassis, and from the rear suspension member. Refer to [PB-7, "Exploded View"](#).

REAR SUSPENSION MEMBER

< UNIT REMOVAL AND INSTALLATION >

12. Remove the rear lower links and the coil springs (LH/RH). Refer to [RSU-9. "Removal and Installation"](#).
13. Remove the shock absorber lower bolts (LH/RH). Refer to [RSU-11. "Exploded View"](#).
14. Set a suitable jack under the rear suspension member.

WARNING:

Place a suitable jack under the center of the rear suspension member.

CAUTION:

Do not damage the rear suspension member with the suitable jack.

15. Remove the rear suspension member stays from the vehicle chassis (LH/RH).
16. Slowly lower the jack. Remove the rear suspension member, the rear suspension arms, the radius rods, the front lower links, and the rear knuckles from the vehicle as a unit.
17. If necessary, remove bolt (1) and separate the rear wheel sensors from the rear knuckles (LH/RH). Refer to [BRC-169. "REAR WHEEL SENSOR : Removal and Installation"](#).

CAUTION:

- Pull out the rear wheel sensor being careful to turn it as little as possible. Do not pull on the wheel sensor harness.
- Failure to remove the rear wheel sensor from the rear knuckle may result in damage to the rear wheel sensor.

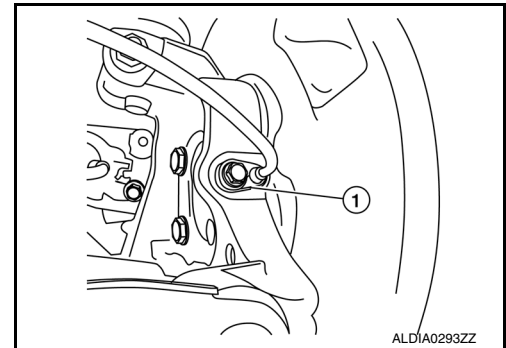

18. If necessary, remove each rear knuckle with the parking brake components and the wheel hub and bearing as an assembly.
19. If necessary, remove the rear suspension arms (LH/RH). Refer to [RSU-18. "Exploded View"](#).
20. If necessary remove the radius rods (LH/RH). Refer to [RSU-13. "Exploded View"](#).
21. If necessary, remove the front lower links (LH/RH). Refer to [RSU-14. "Exploded View"](#).

INSTALLATION

Installation is in the reverse order of the removal.

CAUTION:

- Do not reuse the rear suspension arm nuts at the rear suspension member.
- Do not reuse the rear lower link nuts.
- Do not reuse the front lower link nuts.
- Do not reuse exhaust gaskets.
- Before installation, make sure there is no foreign material, such as iron fragments, adhered to the pick-up part of the rear wheel sensor.
- When installing, make sure there is no foreign material, such as iron fragments, on and in the hole in the rear knuckle for the rear wheel sensor. Make sure no foreign material has been caught in the sensor rotor. Remove any foreign material and clean the mount.
- Do not twist the rear wheel sensor harness when installing the rear wheel sensor. Check that the grommet (2) is fully inserted into the bracket (1). Check that the rear wheel sensor harness is not twisted after installation.

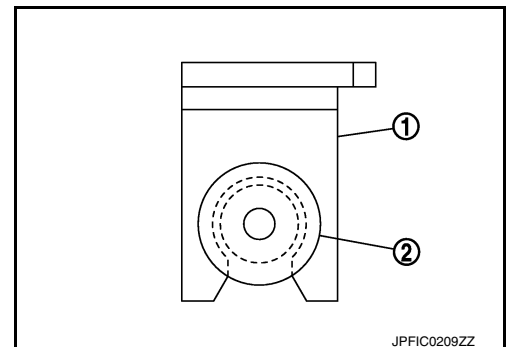

- Perform the final tightening of the parts under unladen conditions with the tires on level ground.
- Check the rear wheel sensor harness for proper connection. Refer to [BRC-168. "REAR WHEEL SENSOR : Exploded View"](#).
- Adjust the parking brake operation (stroke). Refer to [PB-4. "Inspection and Adjustment"](#).
- Check the wheel alignment. Refer to [RSU-6. "Inspection"](#).
- Adjust the neutral position of the steering angle sensor. Refer to [BRC-62. "Description"](#).

REAR SUSPENSION MEMBER

< UNIT REMOVAL AND INSTALLATION >

- For AWD vehicles, check the rear differential gear oil level. Refer to [DLN-103. "Inspection"](#).

A

B

C

D

RSU

F

G

H

I

J

K

L

M

N

O

P

REAR SHOCK ABSORBER

< UNIT DISASSEMBLY AND ASSEMBLY >

UNIT DISASSEMBLY AND ASSEMBLY

REAR SHOCK ABSORBER

Exploded View

INFOID:0000000012894946

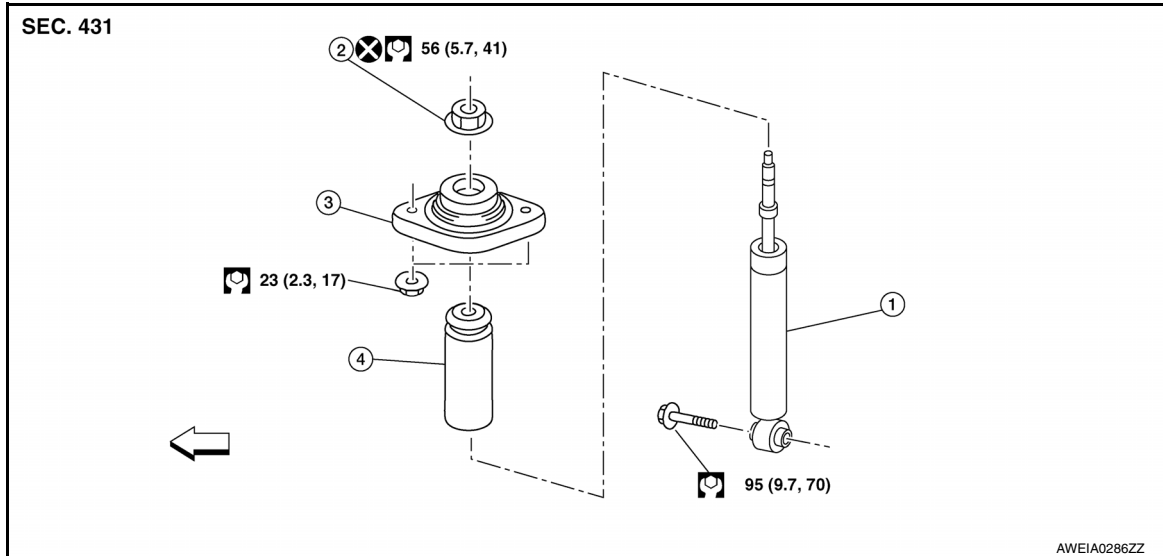

- | | | |
|------------------------|------------------------|-----------------------------|
| 1. Rear shock absorber | 2. Piston rod lock nut | 3. Shock absorber insulator |
| 4. Bound bumper | ← Front | |

Disassembly and Assembly

INFOID:0000000012894947

DISASSEMBLY

CAUTION:

Do not damage the shock absorber piston rod when removing components from the shock absorber.

1. Remove the cap from the shock absorber insulator.
2. Wrap a shop cloth around the lower shock absorber bolt flange. Secure the lower shock absorber bolt flange in a vise.

CAUTION:

Do not set the cylindrical part of the rear shock absorber in a vise.

3. Secure the piston rod tip so that the piston rod does not turn. Remove the piston rod lock nut.
4. Remove the shock absorber insulator and the bound bumper from the rear shock absorber.

ASSEMBLY

Assembly is in the reverse order of disassembly.

CAUTION:

Do not reuse the piston rod lock nut.

SERVICE DATA AND SPECIFICATIONS (SDS)

< SERVICE DATA AND SPECIFICATIONS (SDS)

SERVICE DATA AND SPECIFICATIONS (SDS)

SERVICE DATA AND SPECIFICATIONS (SDS)

Wheel Alignment (Unladen*)

INFOID:0000000012894948

WARNING:

If the vehicle is equipped with the Intelligent Cruise Control (ICC) system and the rear toe has been adjusted during a wheel alignment, the ICC sensor must be aligned. Refer to [CCS-64, "ICC Sensor Adjustment"](#).

A
B
C
D
RSU
F
G
H
I
J
K
L
M
N
O
P

Item		Standard
Camber Degree minute (Decimal degree)	Minimum	-1° 15' (-1.25°)
	Nominal	-0° 45' (-0.75°)
	Maximum	-0° 15' (-0.25°)

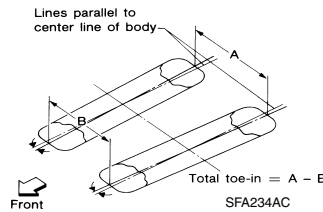

Total toe-in	Distance (A - B)	Minimum	In 0.5 mm (In 0.020 in)
		Nominal	In 3.3 mm (In 0.130 in)
		Maximum	In 6.1 mm (In 0.240 in)
	Angle (LH and RH) Degree minute (Decimal degree)	Minimum	In 0° 2' (In 0.04°)
		Nominal	In 0° 14' (In 0.24°)
		Maximum	In 0° 26' (In 0.44°)

*: Fuel, engine coolant, and lubricants are full. Spare tire, jack, hand tools, and mats are in designated positions.

Ball Joint

INFOID:0000000012894949

Item	Standard
Swinging torque	0.5 – 3.4 N·m (0.05 – 0.35 kg-m, 4 – 30 in-lb)
Rotating torque	0.5 – 3.4 N·m (0.05 – 0.35 kg-m, 4 – 30 in-lb)
Axial end play	0.1 mm (0.004 in)

Wheelarch Height (Unladen*)

INFOID:0000000012894950

UNITED STATES

SERVICE DATA AND SPECIFICATIONS (SDS)

< SERVICE DATA AND SPECIFICATIONS (SDS)

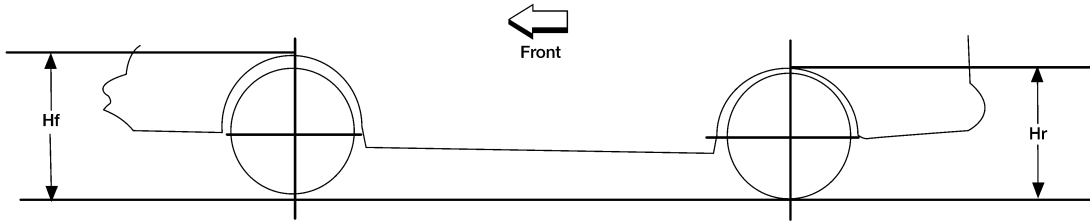

LEIA0085E

Tire size	235/65R18	235/55R20
Front (Hf)	835 mm (32.87 in)	834 mm (32.83 in)
Rear (Hr)	824 mm (32.44 in)	822 mm (32.36 in)

*: Fuel, engine coolant, and lubricants are full. Spare tire, jack, hand tools, and mats are in designated positions.

CANADA

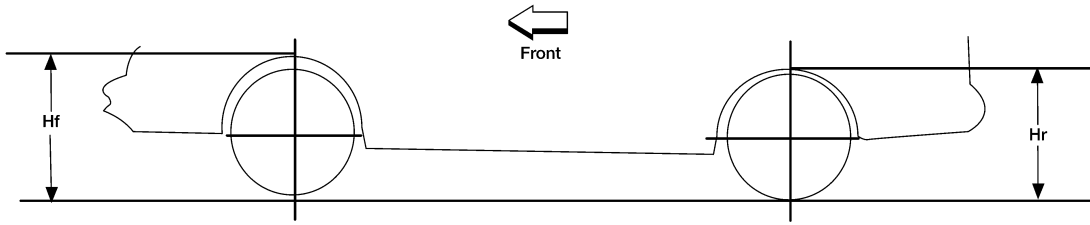

LEIA0085E

Tire size	235/65R18	235/55R20
Front (Hf)	836 mm (32.91 in)	834 mm (32.83 in)
Rear (Hr)	824 mm (32.44 in)	822 mm (32.36 in)

*: Fuel, engine coolant, and lubricants are full. Spare tire, jack, hand tools, and mats are in designated positions.