

SECTION **PWO**  
POWER OUTLET

A  
B  
C

CONTENTS

<b>POWER SOCKET</b>	<b>SYSTEM DESCRIPTION</b> .....	13	F
<b>PRECAUTION</b> .....	<b>COMPONENT PARTS</b> .....	13	G
<b>PRECAUTIONS</b> .....	Component Parts Location .....	13	
Precaution for Supplemental Restraint System (SRS) "AIR BAG" and "SEAT BELT PRE-TENSIONER" .....	Component Description .....	13	
Precaution for Work .....	Inverter Unit .....	14	H
<b>PREPARATION</b> .....	AC 120V Outlet Main Switch .....	14	
<b>PREPARATION</b> .....	AC 120V Outlet .....	14	
Special Service Tool .....	<b>SYSTEM</b> .....	15	I
<b>SYSTEM DESCRIPTION</b> .....	System Diagram .....	15	
<b>COMPONENT PARTS</b> .....	System Description .....	15	
Component Parts Location .....	Fail-safe .....	15	J
<b>WIRING DIAGRAM</b> .....	<b>ECU DIAGNOSIS INFORMATION</b> .....	17	
<b>POWER SOCKET</b> .....	<b>INVERTER UNIT</b> .....	17	K
Wiring Diagram .....	Reference Value .....	17	
<b>REMOVAL AND INSTALLATION</b> .....	Fail-safe .....	18	
<b>POWER SOCKET</b> .....	<b>WIRING DIAGRAM</b> .....	20	L
Removal and Installation .....	<b>INVERTER UNIT</b> .....	20	
<b>AC 120 V OUTLET</b>	Wiring Diagram .....	20	
<b>PRECAUTION</b> .....	<b>BASIC INSPECTION</b> .....	26	PWO
<b>PRECAUTIONS</b> .....	<b>DIAGNOSIS AND REPAIR WORK FLOW</b> .....	26	N
Precaution for Supplemental Restraint System (SRS) "AIR BAG" and "SEAT BELT PRE-TENSIONER" .....	Work Flow .....	26	
Precaution for Work .....	<b>DTC/CIRCUIT DIAGNOSIS</b> .....	28	O
<b>PREPARATION</b> .....	<b>POWER SUPPLY AND GROUND CIRCUIT</b> .....	28	
<b>PREPARATION</b> .....	Diagnosis Procedure .....	28	
Special Service Tool .....	Component Inspection (Inverter Relay) .....	29	P
	<b>AC 120 V OUTLET MAIN SWITCH POWER SUPPLY CIRCUIT</b> .....	31	
	Diagnosis Procedure .....	31	
	<b>AC 120 V OUTLET MAIN SWITCH INPUT SIGNAL CIRCUIT</b> .....	32	
	Diagnosis Procedure .....	32	

Component Inspection (AC 120V Outlet Main Switch) .....	32	<b>NORMAL OPERATING CONDITION</b> .....	42
		Description .....	42
<b>AC 120 V POWER OUTPUT CIRCUIT</b> .....	34	<b>REMOVAL AND INSTALLATION</b> .....	43
Diagnosis Procedure .....	34	<b>INVERTER UNIT</b> .....	43
		Removal and Installation .....	43
<b>AC 120 V OUTLET MAIN SWITCH INDICATOR CIRCUIT</b> .....	37	<b>AC 120V OUTLET MAIN SW</b> .....	44
Diagnosis Procedure (150W Indicator) .....	37	Removal and Installation .....	44
Diagnosis Procedure (400W Indicator) .....	37	<b>AC 120 V OUTLET</b> .....	45
Component Inspection (AC 120V Outlet Main Switch Indicators) .....	38	Removal and Installation .....	45
Component Inspections (A/T Shift Selector) .....	39	<b>SERVICE DATA AND SPECIFICATIONS (SDS)</b> .....	46
<b>SYMPTOM DIAGNOSIS</b> .....	40	<b>SERVICE DATA AND SPECIFICATIONS (SDS)</b> .....	46
<b>NO OUTPUT FROM AC 120 V OUTLET</b> .....	40	AC 120V Outlet .....	46
Diagnosis Procedure .....	40		
<b>AC 120 V OUTLET MAIN SWITCH INDICATOR DOES NOT TURN ON</b> .....	41		
Diagnosis Procedure .....	41		

PRECAUTION

PRECAUTIONS

Precaution for Supplemental Restraint System (SRS) "AIR BAG" and "SEAT BELT PRE-TENSIONER"

INFOID:000000006737423

The Supplemental Restraint System such as "AIR BAG" and "SEAT BELT PRE-TENSIONER", used along with a front seat belt, helps to reduce the risk or severity of injury to the driver and front passenger for certain types of collision. This system includes seat belt switch inputs and dual stage front air bag modules. The SRS system uses the seat belt switches to determine the front air bag deployment, and may only deploy one front air bag, depending on the severity of a collision and whether the front occupants are belted or unbelted. Information necessary to service the system safely is included in the SR and SB section of this Service Manual.

**WARNING:**

- To avoid rendering the SRS inoperative, which could increase the risk of personal injury or death in the event of a collision which would result in air bag inflation, all maintenance must be performed by an authorized NISSAN/INFINITI dealer.
- Improper maintenance, including incorrect removal and installation of the SRS, can lead to personal injury caused by unintentional activation of the system. For removal of Spiral Cable and Air Bag Module, see the SR section.
- Do not use electrical test equipment on any circuit related to the SRS unless instructed to in this Service Manual. SRS wiring harnesses can be identified by yellow and/or orange harnesses or harness connectors.

PRECAUTIONS WHEN USING POWER TOOLS (AIR OR ELECTRIC) AND HAMMERS

**WARNING:**

- When working near the Air Bag Diagnosis Sensor Unit or other Air Bag System sensors with the Ignition ON or engine running, DO NOT use air or electric power tools or strike near the sensor(s) with a hammer. Heavy vibration could activate the sensor(s) and deploy the air bag(s), possibly causing serious injury.
- When using air or electric power tools or hammers, always switch the Ignition OFF, disconnect the battery, and wait at least 3 minutes before performing any service.

Precaution for Work

INFOID:000000007848824

- When removing or disassembling each component, be careful not to damage or deform it. If a component may be subject to interference, be sure to protect it with a shop cloth.
- When removing (disengaging) components with a screwdriver or similar tool, be sure to wrap the component with a shop cloth or vinyl tape to protect it.
- Protect the removed parts with a shop cloth and prevent them from being dropped.
- Replace a deformed or damaged clip.
- If a part is specified as a non-reusable part, always replace it with a new one.
- Be sure to tighten bolts and nuts securely to the specified torque.
- After installation is complete, be sure to check that each part works properly.
- Follow the steps below to clean components.
  - Water soluble dirt: Dip a soft cloth into lukewarm water, and wring the water out of the cloth to wipe the dirty area. Then rub with a soft and dry cloth.
  - Oily dirt: Dip a soft cloth into lukewarm water with mild detergent (concentration: within 2 to 3%), and wipe the dirty area. Then dip a cloth into fresh water, and wring the water out of the cloth to wipe the detergent off. Then rub with a soft and dry cloth.
- Do not use organic solvent such as thinner, benzene, alcohol, or gasoline.
- For genuine leather seats, use a genuine leather seat cleaner.

A  
B  
C  
D  
E  
F  
G  
H  
I  
J  
K  
L  
N  
O  
P

PWO

# PREPARATION

< PREPARATION >

[POWER SOCKET]

## PREPARATION

### PREPARATION

#### Special Service Tool

INFOID:000000006737425

The actual shapes of Kent-Moore tools may differ from those of special service tools illustrated here.

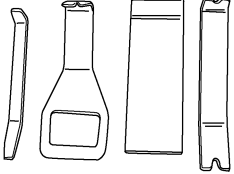
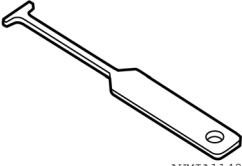
Tool number (Kent-Moore No.) Tool name	Description
— (J-46534) Trim tool set  AWJIA0483ZZ	Removing trim components
— (J-42059) Power socket removal tool  AWMIA1148GB	Removing power sockets

# COMPONENT PARTS

< SYSTEM DESCRIPTION >

[POWER SOCKET]

## SYSTEM DESCRIPTION

### COMPONENT PARTS

#### Component Parts Location

INFOID:000000006928470

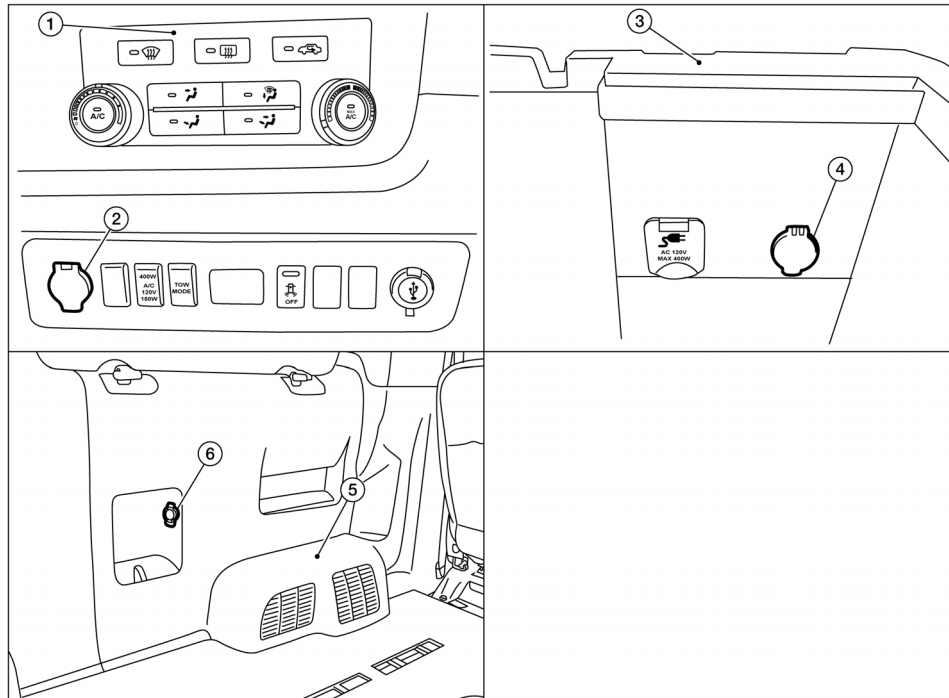

- 1. Front air control
- 2. Front power socket
- 3. Center console
- 4. Console power socket
- 5. Rear heating and cooling assembly
- 6. Third row power socket (passenger van)

ALMIA0541ZZ

A  
B  
C  
D  
E  
F  
G  
H  
I  
J  
K  
L  
N  
O  
P

PWO



POWER SOCKET CONNECTORS

Connector No.	M3
Connector Name	FUSE BLOCK (J/B)
Connector Color	WHITE

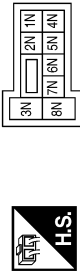

Terminal No.	Color of Wire	Signal Name
2N	O	-

Connector No.	M4
Connector Name	FUSE BLOCK (J/B)
Connector Color	WHITE



Terminal No.	Color of Wire	Signal Name
10P	G	-

Connector No.	M31
Connector Name	WIRE TO WIRE
Connector Color	WHITE

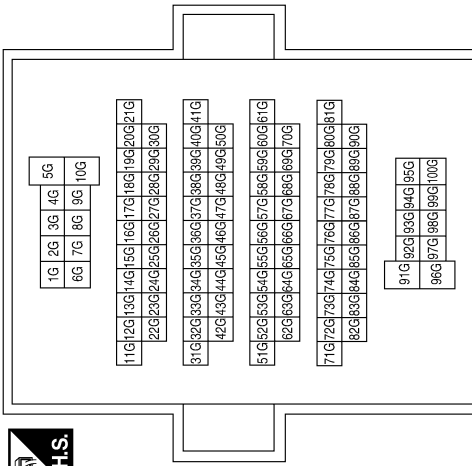

Terminal No.	Color of Wire	Signal Name
7G	L	-
97G	G	-

Connector No.	M32
Connector Name	WIRE TO WIRE
Connector Color	WHITE

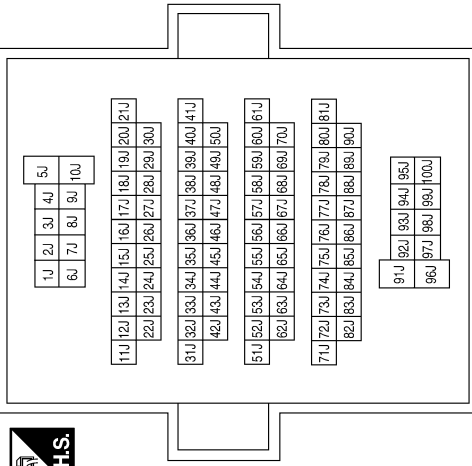

Terminal No.	Color of Wire	Signal Name
91J	R	-

Connector No.	M40
Connector Name	WIRE TO WIRE
Connector Color	WHITE

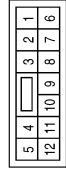

Terminal No.	Color of Wire	Signal Name
4	L	-

A  
B  
C  
D  
E  
F  
G  
H  
I  
J  
K  
L  
P

PWO

AAMIA0922GB

# POWER SOCKET

< WIRING DIAGRAM >

[POWER SOCKET]

Connector No.	M54
Connector Name	FRONT POWER SOCKET
Connector Color	GRAY



Terminal No.	Color of Wire	Signal Name
1	G	-
2	B	-

Connector No.	M179
Connector Name	ACCESSORY SOCKET RELAY
Connector Color	BLUE



Terminal No.	Color of Wire	Signal Name
1	SB	-
2	B	-
3	G	-
5	R	-

Connector No.	E152
Connector Name	WIRE TO WIRE
Connector Color	WHITE

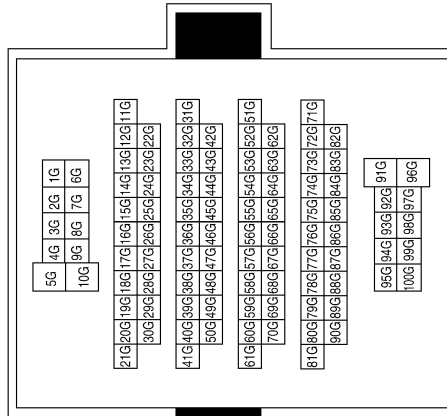

Terminal No.	Color of Wire	Signal Name
7G	L	-
97G	G	-

Connector No.	B20
Connector Name	WIRE TO WIRE
Connector Color	WHITE

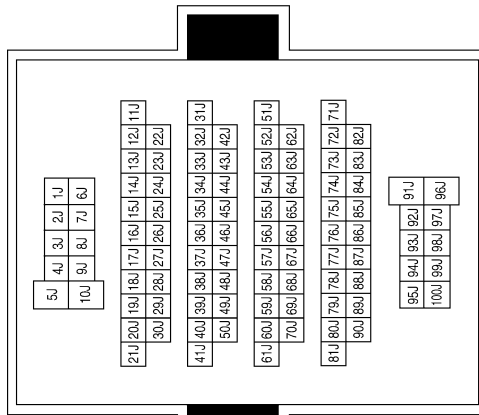

Terminal No.	Color of Wire	Signal Name
91J	R	-

Connector No.	B40
Connector Name	WIRE TO WIRE
Connector Color	GRAY



Terminal No.	Color of Wire	Signal Name
2	L	-
3	B	-



# POWER SOCKET

< WIRING DIAGRAM >

[POWER SOCKET]

Connector No.	B350
Connector Name	WIRE TO WIRE
Connector Color	GRAY



Terminal No.	Color of Wire	Signal Name
2	L	-
3	B	-

Connector No.	B75
Connector Name	THIRD ROW POWER SOCKET
Connector Color	GRAY



Terminal No.	Color of Wire	Signal Name
1	R	-
2	B	-

Connector No.	B69
Connector Name	WIRE TO WIRE
Connector Color	WHITE

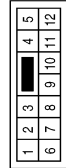

Terminal No.	Color of Wire	Signal Name
4	L	-

Connector No.	B351
Connector Name	CONSOLE POWER SOCKET
Connector Color	GRAY



Terminal No.	Color of Wire	Signal Name
1	L	-
2	B	-

AAMIA0924GB

A  
B  
C  
D  
E  
F  
G  
H  
I  
J  
K  
L  
N  
O  
P

PWO

## REMOVAL AND INSTALLATION

## POWER SOCKET

## Removal and Installation

INFOID:000000006737427

## FRONT POWER SOCKET, CONSOLE POWER SOCKET AND 3RD ROW POWER SOCKET

**NOTE:**

If unable to use the tool because of power socket location or access to the harness connector, then further removal of interior components may be required. Refer to [IP-14, "Exploded View"](#) (Front Power Socket) to remove cluster lid C lower finisher, [IP-25, "Removal and Installation"](#) (Console Power Socket, if equipped) to remove the front center console or [IP-26, "Exploded View"](#) (Third Row Power Socket, if equipped) to remove the rear lower finisher LH.

## Removal

1. Remove the fuse for the power socket.
2. Insert one side of the Tool (A) into one of the square holes inside the power socket.

**Tool number** : — (J-42059)

3. Lift up the handle of the Tool until the other side snaps into the other square hole in the power socket.
4. Pull the power socket straight out with the Tool.

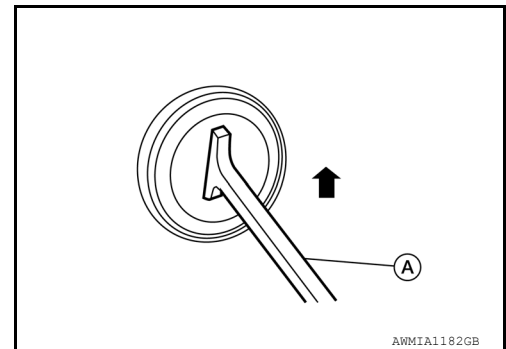

5. Disconnect the harness connector from the power socket.
6. Remove the ring from the power socket finisher while pressing the pawls.

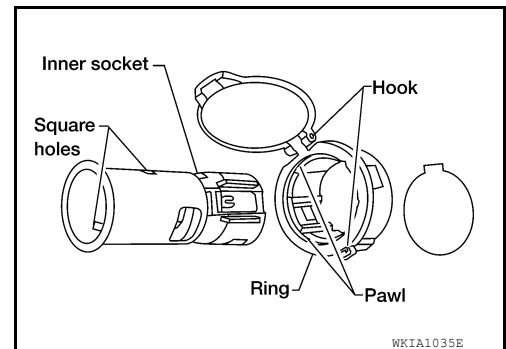

## Installation

Installation is in the reverse order of removal.

**NOTE:**

Make sure to align the tab with the square notched area during installation.

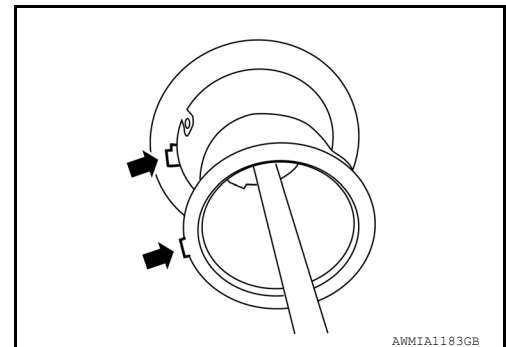

PRECAUTION

PRECAUTIONS

Precaution for Supplemental Restraint System (SRS) "AIR BAG" and "SEAT BELT PRE-TENSIONER"

INFOID:000000007005466

The Supplemental Restraint System such as "AIR BAG" and "SEAT BELT PRE-TENSIONER", used along with a front seat belt, helps to reduce the risk or severity of injury to the driver and front passenger for certain types of collision. This system includes seat belt switch inputs and dual stage front air bag modules. The SRS system uses the seat belt switches to determine the front air bag deployment, and may only deploy one front air bag, depending on the severity of a collision and whether the front occupants are belted or unbelted. Information necessary to service the system safely is included in the SR and SB section of this Service Manual.

**WARNING:**

- To avoid rendering the SRS inoperative, which could increase the risk of personal injury or death in the event of a collision which would result in air bag inflation, all maintenance must be performed by an authorized NISSAN/INFINITI dealer.
- Improper maintenance, including incorrect removal and installation of the SRS, can lead to personal injury caused by unintentional activation of the system. For removal of Spiral Cable and Air Bag Module, see the SR section.
- Do not use electrical test equipment on any circuit related to the SRS unless instructed to in this Service Manual. SRS wiring harnesses can be identified by yellow and/or orange harnesses or harness connectors.

PRECAUTIONS WHEN USING POWER TOOLS (AIR OR ELECTRIC) AND HAMMERS

**WARNING:**

- When working near the Air Bag Diagnosis Sensor Unit or other Air Bag System sensors with the Ignition ON or engine running, DO NOT use air or electric power tools or strike near the sensor(s) with a hammer. Heavy vibration could activate the sensor(s) and deploy the air bag(s), possibly causing serious injury.
- When using air or electric power tools or hammers, always switch the Ignition OFF, disconnect the battery, and wait at least 3 minutes before performing any service.

Precaution for Work

INFOID:000000007848825

- When removing or disassembling each component, be careful not to damage or deform it. If a component may be subject to interference, be sure to protect it with a shop cloth.
- When removing (disengaging) components with a screwdriver or similar tool, be sure to wrap the component with a shop cloth or vinyl tape to protect it.
- Protect the removed parts with a shop cloth and prevent them from being dropped.
- Replace a deformed or damaged clip.
- If a part is specified as a non-reusable part, always replace it with a new one.
- Be sure to tighten bolts and nuts securely to the specified torque.
- After installation is complete, be sure to check that each part works properly.
- Follow the steps below to clean components.
  - Water soluble dirt: Dip a soft cloth into lukewarm water, and wring the water out of the cloth to wipe the dirty area. Then rub with a soft and dry cloth.
  - Oily dirt: Dip a soft cloth into lukewarm water with mild detergent (concentration: within 2 to 3%), and wipe the dirty area. Then dip a cloth into fresh water, and wring the water out of the cloth to wipe the detergent off. Then rub with a soft and dry cloth.
- Do not use organic solvent such as thinner, benzene, alcohol, or gasoline.
- For genuine leather seats, use a genuine leather seat cleaner.

A  
B  
C  
D  
E  
F  
G  
H  
I  
J  
K  
L  
N  
O  
P

PWO

# PREPARATION

< PREPARATION >

[AC 120 V OUTLET]

## PREPARATION

### PREPARATION

#### Special Service Tool

INFOID:000000007902097

The actual shapes of Kent-Moore tools may differ from those of special service tools illustrated here.

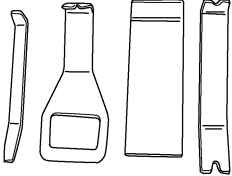
Tool number (Kent-Moore No.) Tool name	Description
<p>— (J-46534) Trim tool set</p>  <p>AWJIA04832Z</p>	Removing trim components

# COMPONENT PARTS

< SYSTEM DESCRIPTION >

[AC 120 V OUTLET]

## SYSTEM DESCRIPTION

### COMPONENT PARTS

#### Component Parts Location

INFOID:000000006928472

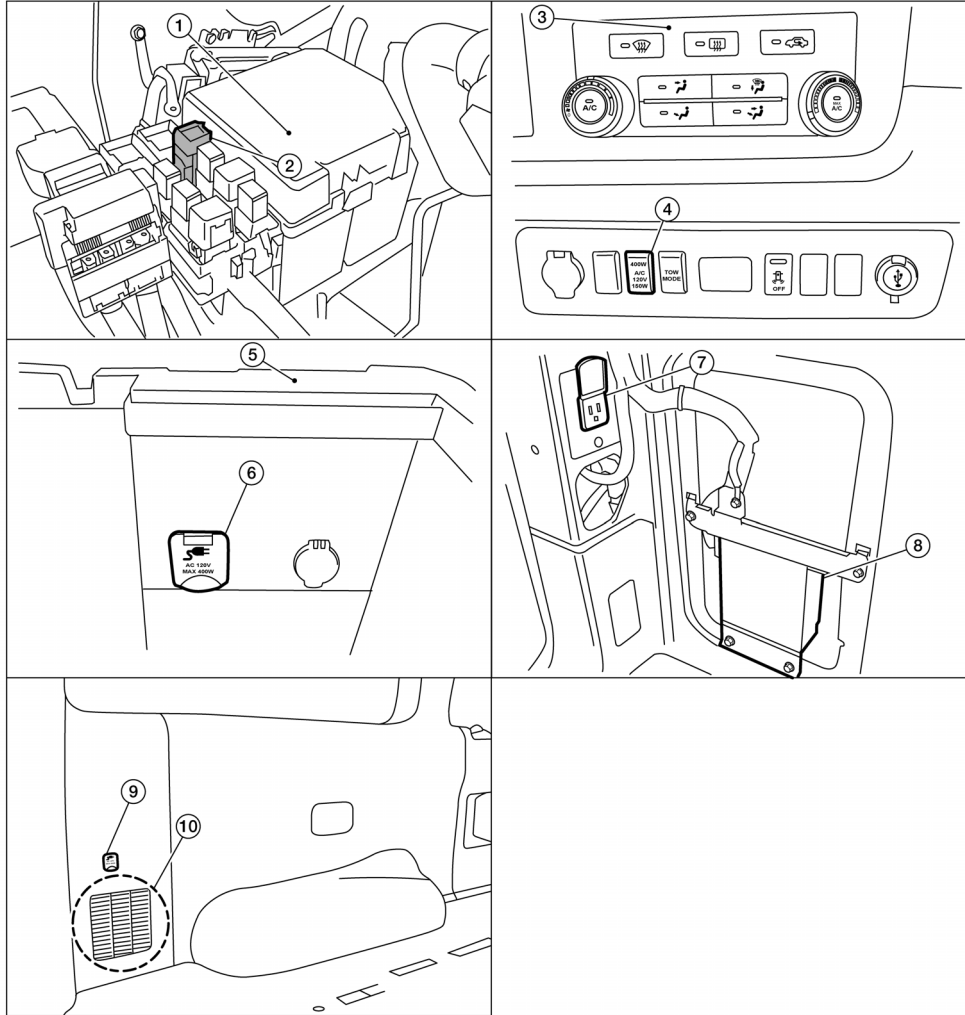

ALMIA05422Z

- |                                    |   |  |
|------------------------------------|---|--|
| 1. IPDM E/R                        | 2. Inverter relay (view with relay box cover removed)                     | 3. Front air control                   |
| 4. AC 120V outlet main switch      | 5. Center console   | 6. AC 120V outlet front                |
| 7. AC 120V outlet rear (cargo van) | 8. Inverter unit (view with left rear finisher panel removed) (cargo van) | 9. AC 120V outlet rear (passenger van) |
| 10. Inverter unit (passenger van)  |   |  |

#### Component Description

INFOID:000000006928473

Component	Reference
Inverter unit	<a href="#">PWO-14, "Inverter Unit"</a>
AC 120V outlet main switch	<a href="#">PWO-14, "AC 120V Outlet Main Switch"</a>
AC 120V outlet	<a href="#">PWO-14, "AC 120V Outlet"</a>

A  
B  
C  
D  
E  
F  
G  
H  
I  
J  
K  
L  
N  
O  
P

PWO

## COMPONENT PARTS

< SYSTEM DESCRIPTION >

[AC 120 V OUTLET]

---

### Inverter Unit

*INFOID:000000006928474*

The inverter unit converts 12V DC to 120V AC.

### AC 120V Outlet Main Switch

*INFOID:000000006928475*

The AC outlet main switch allows operation of the inverter unit in 150W AC 120V and 400W AC 120V modes.

### AC 120V Outlet

*INFOID:000000006928476*

The AC 120V outlet front and AC 120V outlet rear allow use of AC components up to 400W.

SYSTEM

System Diagram

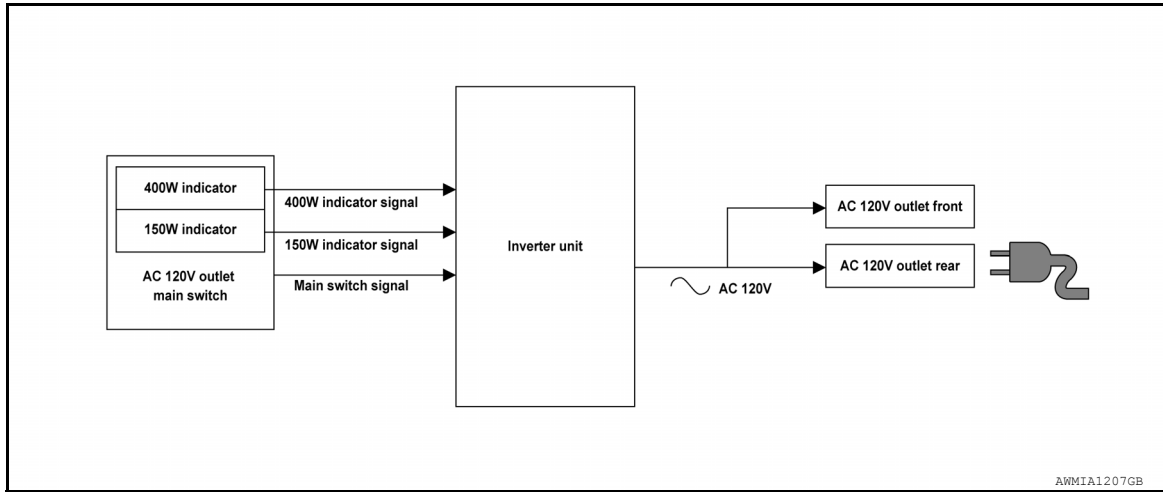

System Description

INFOID:000000006928477

- When turning ON the AC 120V outlet main switch with the ignition switch ON, the 150W indicator turns ON and the inverter unit is activated allowing the use of devices up to 150W.
- When the vehicle is placed in P (Park) with the ignition switch ON, turning ON the AC 120V outlet main switch turns ON the 400W indicator and the inverter unit is activated, allowing the use of devices up to 400W.
- The inverter unit converts 12V DC to 120V AC and outputs the converted voltage to the AC 120V outlet front and AC 120V outlet rear two seconds after the AC 120V outlet main switch is turned ON.

Fail-safe

INFOID:000000007016750

When a malfunction listed below occurs, the inverter unit turns OFF the AC 120V outlet main switch indicator and stops the output.

Malfunction item	Fail-safe condition	Fail-safe cancellation condition
Inverter unit power supply voltage is greater than 15V	When inverter unit input voltage rises above 15V, the output will be suspended to protect the inverter unit.	After the inverter unit power supply voltage drops below 15V, the AC 120V outlet main switch ON ⇒ OFF ⇒ ON operation allows normal return.
Inverter unit power supply voltage is less than 11.5V for 2 seconds or more	When inverter unit input voltage is lowered, the output will be suspended to protect the battery from running out.	After the inverter unit power supply voltage rises above 11.5V, the AC 120V outlet main switch ON ⇒ OFF ⇒ ON operation allows normal return.
Inverter unit power supply voltage is less than 9V		
Inverter unit AC 120V output voltage is greater than 170V	When inverter unit AC 120V output voltage is greater than 170V, the output will be suspended.	After the inverter unit AC 120V output voltage drops below 170V, the AC 120V outlet main switch ON ⇒ OFF ⇒ ON operation allows normal return.
Inverter unit output current is greater than 3.7A (400W mode)	When inverter unit output current rises above 3.7A, the output will be suspended to prevent over current (e.g., connecting an electric appliance exceeding rated output).	After the inverter unit output current drops below 3.7A, the AC 120V outlet main switch ON ⇒ OFF ⇒ ON operation allows normal return.
Inverter unit input current is greater than 13.3A (150W mode)	When inverter unit input current rises above 13.3A, the output will be suspended to prevent over current (e.g., connecting an electric appliance exceeding rated output).	After the inverter unit input current drops below 13.3A, the AC 120V outlet main switch ON ⇒ OFF ⇒ ON operation allows normal return.

A  
B  
C  
D  
E  
F  
G  
H  
I  
J  
K  
L  
N  
O  
P

PWO

# SYSTEM

< SYSTEM DESCRIPTION >

[AC 120 V OUTLET]

Malfunction item	Fail-safe condition	Fail-safe cancellation condition
Inverter unit is overheated	When the inverter unit is overheated [thermistor temperature above 100°C (212°F)], the output will be suspended to protect the inverter unit.	After the inverter unit temperature is lowered, the AC 120V outlet main switch ON ⇒ OFF ⇒ ON operation allows normal return.
Inverter unit output signal (AC 120V output signal) is shorted	When inverter unit output signal is shorted, the output will be suspended.	After recovering from inverter unit output signal short, the AC 120V outlet main switch ON ⇒ OFF ⇒ ON operation allows normal return.



# INVERTER UNIT

< ECU DIAGNOSIS INFORMATION >

[AC 120 V OUTLET]

## ECU DIAGNOSIS INFORMATION

### INVERTER UNIT

Reference Value

INFOID:000000006928479

#### TERMINAL LAYOUT

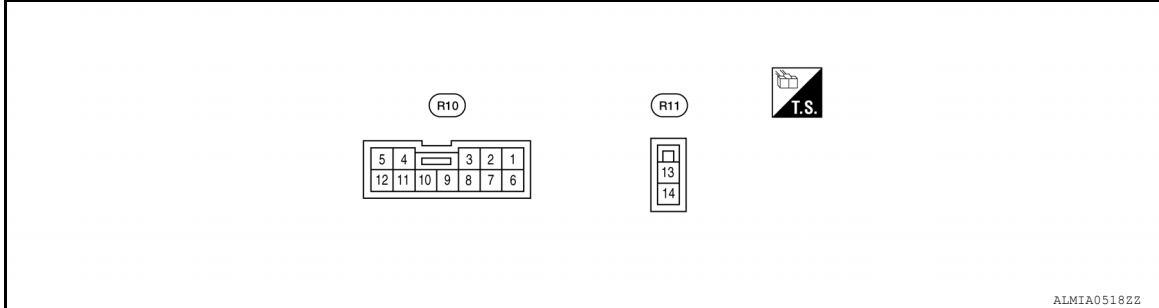

#### PHYSICAL VALUES

Terminal No. (Wire color)		Description		Condition		Value (Approx.)
+	-	Signal name	Input/ Output			
1 (L)	Ground	AC sw signal input	Input	Ignition switch ON	AC 120V outlet main switch OFF	0V
					AC 120V outlet main switch ON	12V
3 (G)	Ground	400W indicator drive signal	Input	Ignition switch ON	AC 120V outlet main switch OFF	0V
					AC 120V outlet main switch ON	12V
5 (G)	11 (Y)	AC output 1	Output	Ignition switch ON	AC 120V outlet main switch OFF	0V
					AC 120V outlet main switch ON (Using circuit tester)	AC 120V
					AC 120V outlet main switch ON (Using oscilloscope)	<div style="text-align: center;"> <p>Reference value</p> <p>RMS 120V</p> <p>5ms</p> <p>JSMIA0397GB</p> </div>
6 (W)	Ground	Input park signal	Input	Ignition switch ON	AC 120V outlet main switch OFF	0V
					AC 120V outlet main switch ON with A/T selec- tor lever in P (Park)	12V
7 (SB)	Ground	RLY output signal	Input	Ignition switch ON	AC 120V outlet main switch OFF	0V
					AC 120V outlet main switch ON	12V

PWO

# INVERTER UNIT

< ECU DIAGNOSIS INFORMATION >

[AC 120 V OUTLET]

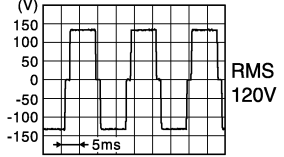
Terminal No. (Wire color)		Description		Condition	Value (Approx.)	
+	-	Signal name	Input/ Output			
11 (Y)	5 (G)	AC output 2	Output	Ignition switch ON	AC 120V outlet main switch OFF	0V
					AC 120V outlet main switch ON (Using circuit tester)	AC 120V
					AC 120V outlet main switch ON (Using oscilloscope)	Reference value  AC 120V
13 (B)	Ground	Ground	—	Ignition switch ON	0V	
14 (W)		Battery power supply	Input	Ignition switch ON	AC 120V outlet main switch OFF	0V
					AC 120V outlet main switch ON	Battery voltage

**CAUTION:**

- To measure AC 120V output signal, always use the circuit tester or oscilloscope AC range. Never allow the probes to contact each other.
- Because of modified sine wave output of the AC 120V output signal, voltage cannot be measured accurately without using a circuit tester that can measure true RMS (root mean square).

**Fail-safe**

INFOID:000000006928480

When a malfunction listed below occurs, the inverter unit turns OFF the AC 120V outlet main switch indicator and stops the output.

Malfunction item	Fail-safe condition	Fail-safe cancellation condition
Inverter unit power supply voltage is greater than 15V	When inverter unit input voltage rises above 15V, the output will be suspended to protect the inverter unit.	After the inverter unit power supply voltage drops below 15V, the AC 120V outlet main switch ON ⇒ OFF ⇒ ON operation allows normal return.
Inverter unit power supply voltage is less than 11.5V for 2 seconds or more	When inverter unit input voltage is lowered, the output will be suspended to protect the battery from running out.	After the inverter unit power supply voltage rises above 11.5V, the AC 120V outlet main switch ON ⇒ OFF ⇒ ON operation allows normal return.
Inverter unit power supply voltage is less than 9V		
Inverter unit AC 120V output voltage is greater than 170V	When inverter unit AC 120V output voltage is greater than 170V, the output will be suspended.	After the inverter unit AC 120V output voltage drops below 170V, the AC 120V outlet main switch ON ⇒ OFF ⇒ ON operation allows normal return.
Inverter unit output current is greater than 3.7A (400W mode)	When inverter unit output current rises above 3.7A, the output will be suspended to prevent over current (e.g., connecting an electric appliance exceeding rated output).	After the inverter unit output current drops below 3.7A, the AC 120V outlet main switch ON ⇒ OFF ⇒ ON operation allows normal return.
Inverter unit input current is greater than 13.3A (150W mode)	When inverter unit input current rises above 13.3A, the output will be suspended to prevent over current (e.g., connecting an electric appliance exceeding rated output).	After the inverter unit input current drops below 13.3A, the AC 120V outlet main switch ON ⇒ OFF ⇒ ON operation allows normal return.

# INVERTER UNIT

< ECU DIAGNOSIS INFORMATION >

[AC 120 V OUTLET]

Malfunction item	Fail-safe condition	Fail-safe cancellation condition
Inverter unit is overheated	When the inverter unit is overheated [thermistor temperature above 100°C (212°F)], the output will be suspended to protect the inverter unit.	After the inverter unit temperature is lowered, the AC 120V outlet main switch ON ⇒ OFF ⇒ ON operation allows normal return.
Inverter unit output signal (AC 120V output signal) is shorted	When inverter unit output signal is shorted, the output will be suspended.	After recovering from inverter unit output signal short, the AC 120V outlet main switch ON ⇒ OFF ⇒ ON operation allows normal return.

A  
B  
C  
D  
E  
F  
G  
H  
I  
J  
K  
L

PWO

N  
O  
P

# INVERTER UNIT

< WIRING DIAGRAM >

[AC 120 V OUTLET]

## WIRING DIAGRAM

### INVERTER UNIT

Wiring Diagram

INFOID:000000006928481

#### INVERTER SYSTEM

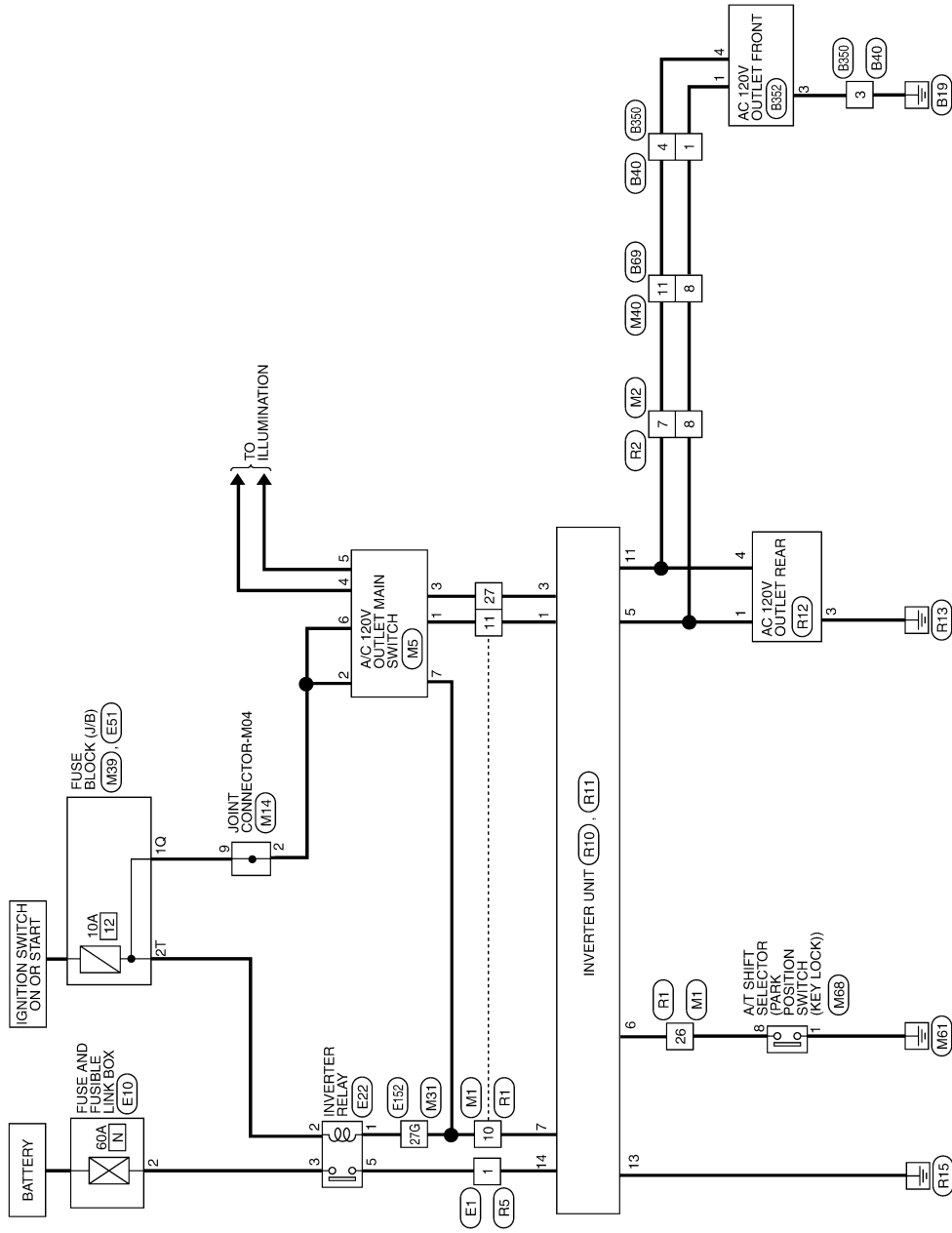

ABMWA1150GB

# INVERTER UNIT

< WIRING DIAGRAM >

[AC 120 V OUTLET]

## INVERTER SYSTEM CONNECTORS

Connector No.	M1
Connector Name	WIRE TO WIRE
Connector Color	WHITE

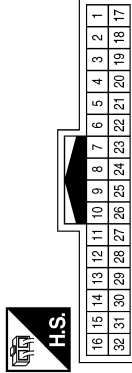

Terminal No.	Color of Wire	Signal Name
10	SB	-
11	L	-
26	W	-
27	G	-

Connector No.	M14
Connector Name	JOINT CONNECTOR-M04
Connector Color	BLUE

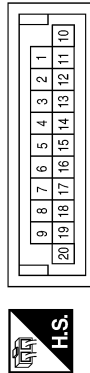

Terminal No.	Color of Wire	Signal Name
2	R	-
9	R	-

Connector No.	M2
Connector Name	WIRE TO WIRE
Connector Color	WHITE



Terminal No.	Color of Wire	Signal Name
7	Y	-
8	G	-

Connector No.	M31
Connector Name	WIRE TO WIRE
Connector Color	WHITE

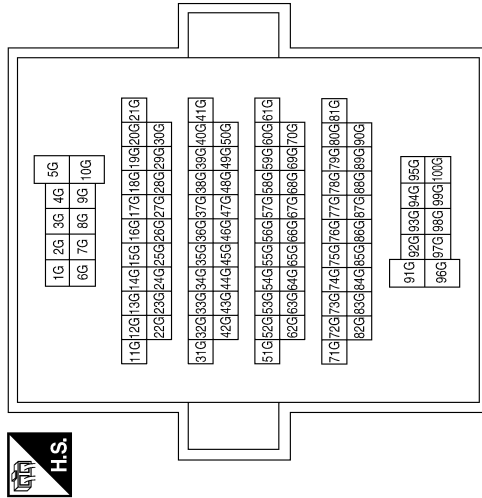

Connector No.	M5
Connector Name	A/C 120V OUTLET MAIN SWITCH
Connector Color	WHITE



Terminal No.	Color of Wire	Signal Name
1	L	SWITCH OUT
2	R	IGN
3	G	400W OUTPUT (IND)
4	V	ILL CONT SW (+)
5	BR	ILL CONT SW (-)
6	R	IGN
7	SB	150W OUTPUT (IND)

Terminal No.	Color of Wire	Signal Name
27G	SB	-

A B C D E F G H I J K L N O P

PWO

# INVERTER UNIT

< WIRING DIAGRAM >

[AC 120 V OUTLET]

Connector No.	M68
Connector Name	A/T SHIFT SELECTOR
Connector Color	WHITE

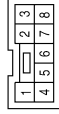

Terminal No.	Color of Wire	Signal Name
1	B	-
8	W	-

Connector No.	M40
Connector Name	WIRE TO WIRE
Connector Color	WHITE

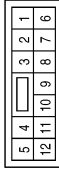

Terminal No.	Color of Wire	Signal Name
8	G	-
11	Y	-

Connector No.	M39
Connector Name	FUSE BLOCK (J/B)
Connector Color	WHITE

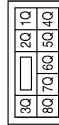

Terminal No.	Color of Wire	Signal Name
1Q	R	-

Connector No.	E22
Connector Name	INVERTER RELAY
Connector Color	BLUE



Terminal No.	Color of Wire	Signal Name
1	SB	-
2	W	-
3	R	-
5	W	-

Connector No.	E10
Connector Name	FUSE AND FUSIBLE LINK BOX
Connector Color	BLACK



Terminal No.	Color of Wire	Signal Name
2	R	-

Connector No.	E1
Connector Name	WIRE TO WIRE
Connector Color	BLACK



Terminal No.	Color of Wire	Signal Name
1	W	-

ABMIA2710GB

# INVERTER UNIT

< WIRING DIAGRAM >

[AC 120 V OUTLET]

Terminal No.	Color of Wire	Signal Name
27G	SB	-

Connector No.	E152
Connector Name	WIRE TO WIRE
Connector Color	WHITE

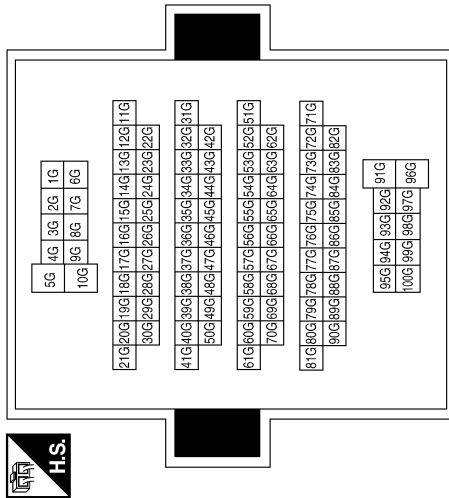

Connector No.	E51
Connector Name	FUSE BLOCK (J/B)
Connector Color	WHITE



Terminal No.	Color of Wire	Signal Name
2T	W	-

Connector No.	B350
Connector Name	WIRE TO WIRE
Connector Color	GRAY

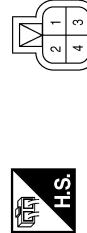

Terminal No.	Color of Wire	Signal Name
1	G	-
3	B	-
4	Y	-

Connector No.	B69
Connector Name	WIRE TO WIRE
Connector Color	WHITE

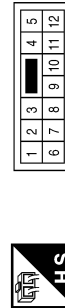

Terminal No.	Color of Wire	Signal Name
8	G	-
11	Y	-

Connector No.	B40
Connector Name	WIRE TO WIRE
Connector Color	GRAY



Terminal No.	Color of Wire	Signal Name
1	G	-
3	B	-
4	Y	-

ABMIA2711GB

A  
B  
C  
D  
E  
F  
G  
H  
I  
J  
K  
L  
N  
O  
P

PWO

# INVERTER UNIT

< WIRING DIAGRAM >

[AC 120 V OUTLET]

Connector No.	B352
Connector Name	AC 120V OUTLET FRONT
Connector Color	WHITE

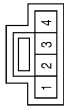

Terminal No.	Color of Wire	Signal Name
1	G	AC1
3	B	GND
4	Y	AC2

Connector No.	R1
Connector Name	WIRE TO WIRE
Connector Color	WHITE

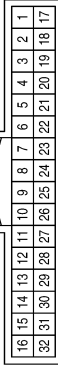

Terminal No.	Color of Wire	Signal Name
10	SB	-
11	L	-
26	W	-
27	G	-

Connector No.	R2
Connector Name	WIRE TO WIRE
Connector Color	WHITE

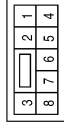

Terminal No.	Color of Wire	Signal Name
7	Y	-
8	G	-

Connector No.	R5
Connector Name	WIRE TO WIRE
Connector Color	BLACK



Terminal No.	Color of Wire	Signal Name
1	W	-

Connector No.	R10
Connector Name	INVERTER UNIT
Connector Color	WHITE



Terminal No.	Color of Wire	Signal Name
1	L	AC SW SIGNAL INPUT
2	-	-
3	G	400W INDICATOR DRIVE
4	-	-
5	G	AC OUTPUT 1
6	W	INPUT PARK SIGNAL
7	SB	RLY OUTPUT
8	-	-
9	-	-
10	-	-
11	Y	AC OUTPUT 2
12	-	-

Connector No.	R11
Connector Name	INVERTER UNIT
Connector Color	WHITE



Terminal No.	Color of Wire	Signal Name
13	B	GND
14	W	POWER



# INVERTER UNIT

< WIRING DIAGRAM >

[AC 120 V OUTLET]

A  
B  
C  
D  
E  
F  
G  
H  
I  
J  
K  
L  
N  
O  
P

Connector No.	R12
Connector Name	AC 120V OUTLET REAR
Connector Color	WHITE

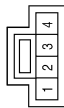

Terminal No.	Color of Wire	Signal Name
1	G	AC 1
3	B	GND
4	Y	AC 2

PWO

ABMIA2913GB

# DIAGNOSIS AND REPAIR WORK FLOW

< BASIC INSPECTION >

[AC 120 V OUTLET]

## BASIC INSPECTION

### DIAGNOSIS AND REPAIR WORK FLOW

Work Flow

INFOID:000000006928482

#### OVERALL SEQUENCE

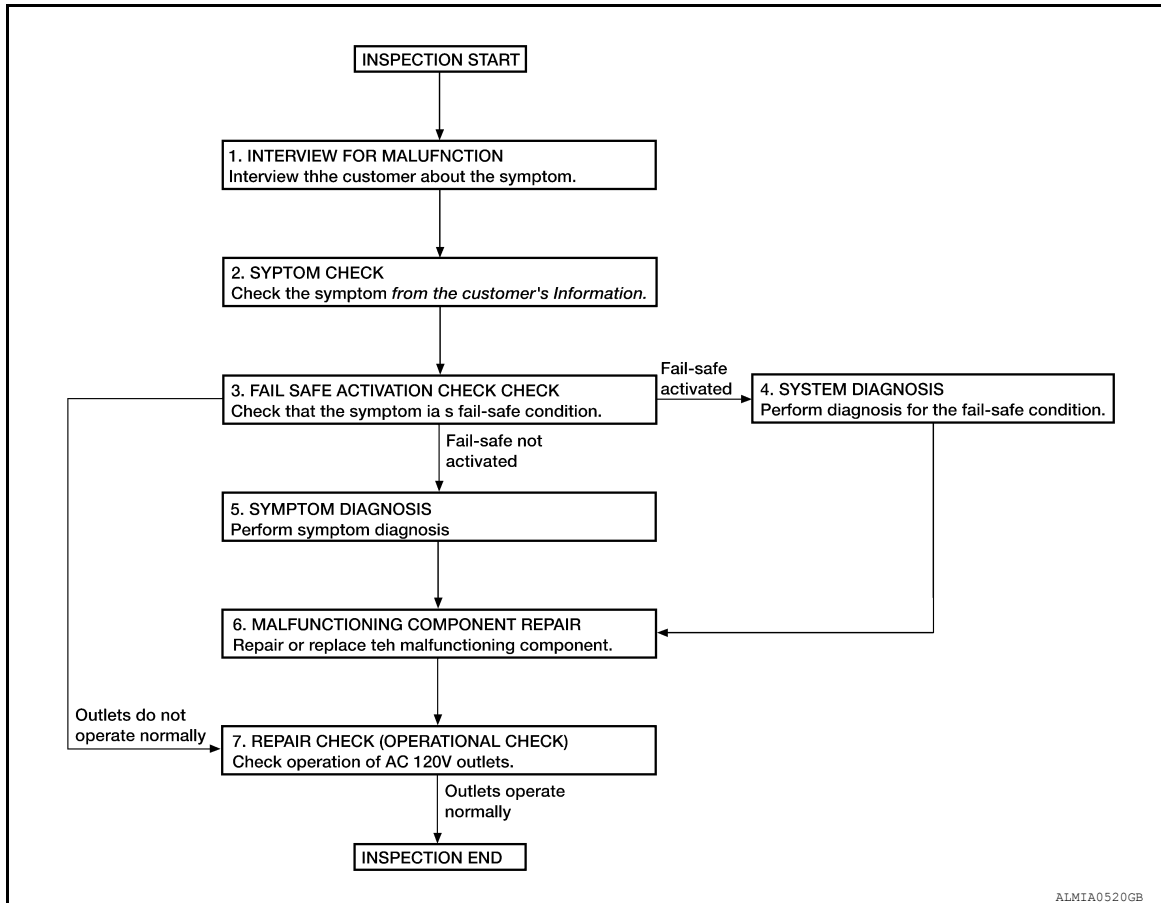

#### DETAILED FLOW

##### 1. INTERVIEW FOR MALFUNCTION

Interview the customer about the symptom.

>> GO TO 2.

##### 2. SYMPTOM CHECK

Check the symptom from the customer's information.

>> GO TO 3.

##### 3. FAIL-SAFE ACTIVATION CHECK

Check that the symptom is a fail-safe condition.

Is fail-safe activated?

YES >> GO TO 4.

NO >> GO TO 5.

##### 4. SYSTEM DIAGNOSIS

Perform diagnosis for the fail-safe activated system. Specify the malfunctioning component.

# DIAGNOSIS AND REPAIR WORK FLOW

< BASIC INSPECTION >

[AC 120 V OUTLET]

>> GO TO 6.

## 5. SYMPTOM DIAGNOSIS

Perform symptom diagnosis. Specify the malfunctioning component.

>> GO TO 6.

## 6. MALFUNCTIONING COMPONENT REPAIR

Repair or replace the malfunctioning component.

>> GO TO 7.

## 7. REPAIR CHECK (OPERATION CHECK)

Check operation of AC 120V outlets.

Do the outlets operate normally?

YES >> Inspection End.

NO >> GO TO 3.

A

B

C

D

E

F

G

H

I

J

K

L

PWO

N

O

P

# POWER SUPPLY AND GROUND CIRCUIT

< DTC/CIRCUIT DIAGNOSIS >

[AC 120 V OUTLET]

## DTC/CIRCUIT DIAGNOSIS

### POWER SUPPLY AND GROUND CIRCUIT

#### Diagnosis Procedure

INFOID:000000006928483

Regarding Wiring Diagram information, refer to [PWO-20, "Wiring Diagram"](#).

#### 1. CHECK FUSE AND FUSIBLE LINK

Check that the following fuse and fusible link are not blown.

Signal name	Fuse or Fusible Link No. or Letter
Ignition switch ON or START	12 (10A)
Battery power supply	N (60A)

Is the fuse or fusible link blown?

- YES >> Replace the blown fuse or fusible link after repairing the affected circuit.  
NO >> GO TO 2.

#### 2. CHECK INVERTER RELAY

Check inverter relay. Refer to [PWO-29, "Component Inspection \(Inverter Relay\)"](#).

Is the inspection result normal?

- YES >> GO TO 3.  
NO >> Replace inverter relay.

#### 3. CHECK INVERTER UNIT POWER SUPPLY CIRCUIT

1. Connect inverter relay connector.
2. Disconnect inverter unit connector R10.
3. Connect a fused jumper wire between inverter unit connector R10 terminal 7 and ground.
4. Turn ignition switch ON.
5. Check voltage between inverter unit connector R11 terminal 14 and ground.

Inverter unit		Ground	Voltage (Approx.)
Connector	Terminal		
R11	14	—	Battery voltage

Is the inspection result normal?

- YES >> GO TO 7.  
NO >> GO TO 4.

#### 4. CHECK INVERTER RELAY POWER SUPPLY CIRCUITS

1. Turn ignition switch OFF.
2. Disconnect inverter relay connector.
3. Check voltage between inverter relay connector E22 terminal 3 and ground.

Inverter relay		Ground	Voltage (Approx.)
Connector	Terminal		
E22	3	—	Battery voltage

4. Turn ignition switch ON.
5. Check voltage between inverter relay connector E22 terminal 2 and ground.

Inverter relay		Ground	Condition	Voltage (Approx.)
Connector	Terminal			

# POWER SUPPLY AND GROUND CIRCUIT

< DTC/CIRCUIT DIAGNOSIS >

[AC 120 V OUTLET]

E22	2	—	Ignition switch ON	Battery voltage
			Ignition switch OFF	0V

Is the inspection result normal?

YES >> GO TO 5.

NO >> Repair or replace the inverter relay power supply circuit.

## 5. CHECK INVERTER UNIT POWER SUPPLY CIRCUIT FOR OPEN

1. Turn ignition switch OFF.
2. Disconnect inverter unit connector R11.
3. Check continuity between inverter relay connector E22 terminal 5 and inverter unit connector R11 terminal 14.

Inverter relay		Inverter unit		Continuity
Connector	Terminal	Connector	Terminal	
E22	5	R11	14	Yes

Is the inspection result normal?

YES >> GO TO 6.

NO >> Repair or replace the inverter unit power supply circuit.

## 6. CHECK INVERTER RELAY COIL CIRCUIT FOR OPEN

Check continuity between inverter relay connector E22 terminal 1 and inverter unit connector R10 terminal 7.

Inverter relay		Inverter unit		Continuity
Connector	Terminal	Connector	Terminal	
E22	1	R10	7	Yes

Is the inspection result normal?

YES >> GO TO 7.

NO >> Repair or replace the inverter unit coil circuit.

## 7. CHECK INVERTER UNIT GROUND CIRCUIT

1. Turn ignition switch OFF.
2. Check continuity between inverter unit connector R11 terminal 13 and ground.

Inverter unit		Ground	Continuity
Connector	Terminal		
R11	13	—	Yes

Is the inspection result normal?

YES >> Inspection End.

NO >> Repair or replace the inverter unit ground circuit.

## Component Inspection (Inverter Relay)

INFOID:000000007004276

### 1. CHECK INVERTER RELAY

1. Turn ignition switch OFF.
2. Disconnect inverter relay connector.
3. Apply battery voltage to inverter relay terminal 2 and ground to terminal 1.
4. Check continuity between inverter relay terminals 3 and 5.

Inverter relay terminals	Condition	Continuity
3 – 5	Battery voltage applied to terminal 2 and ground to terminal 1	Yes
	Voltage and ground removed	No

## POWER SUPPLY AND GROUND CIRCUIT

< DTC/CIRCUIT DIAGNOSIS >

[AC 120 V OUTLET]

---

Is the inspection result normal?

- YES >> Inspection End.
- NO >> Replace inverter relay.

# AC 120 V OUTLET MAIN SWITCH POWER SUPPLY CIRCUIT

< DTC/CIRCUIT DIAGNOSIS >

[AC 120 V OUTLET]

## AC 120 V OUTLET MAIN SWITCH POWER SUPPLY CIRCUIT

### Diagnosis Procedure

INFOID:000000006928484

Regarding Wiring Diagram information, refer to [PWO-20, "Wiring Diagram"](#).

#### 1. CHECK FUSE

Check that the following fuse is not blown.

Signal name	Fuse No.
Ignition switch ON or START	12 (10A)

Is the fuse blown?

- YES >> Replace the blown fuse after repairing the affected circuit.
- NO >> GO TO 2.

#### 2. CHECK POWER SUPPLY FOR AC 120V OUTLET MAIN SWITCH

1. Turn ignition switch ON.
2. Check for voltage between the AC 120V outlet main switch connector and ground.

AC 120V outlet main switch		Ground	Condition	Voltage (Approx.)
Connector	Terminal			
M5	2	—	Ignition switch ON	Battery voltage
			Ignition switch OFF	0V

Is the inspection result normal?

- YES >> Inspection End.
- NO >> Repair or replace the AC 120V main switch power supply circuit.

A  
B  
C  
D  
E  
F  
G  
H  
I  
J  
K  
L

PWO

# AC 120 V OUTLET MAIN SWITCH INPUT SIGNAL CIRCUIT

< DTC/CIRCUIT DIAGNOSIS >

[AC 120 V OUTLET]

## AC 120 V OUTLET MAIN SWITCH INPUT SIGNAL CIRCUIT

### Diagnosis Procedure

INFOID:000000006928485

Regarding Wiring Diagram information, refer to [PWO-20. "Wiring Diagram"](#).

### 1. CHECK AC 120V OUTLET MAIN SWITCH INPUT SIGNAL

1. Turn ignition switch ON.
2. AC 120V outlet main switch ON.
3. Check for voltage between the inverter unit harness connector R10 terminal 1 and ground.

Inverter unit		Ground	Condition	Voltage (Approx.)
Connector	Terminal			
R10	1	—	AC 120V outlet main switch OFF	0V
			AC 120V outlet main switch ON	Battery voltage

Is the inspection result normal?

- YES >> Inspection End.  
NO >> GO TO 2.

### 2. CHECK AC 120V OUTLET MAIN SWITCH

Check AC 120V outlet main switch. Refer to [PWO-32. "Component Inspection \(AC 120V Outlet Main Switch\)"](#).

Is the inspection result normal?

- YES >> GO TO 3.  
NO >> Replace AC 120V outlet main switch.

### 3. CHECK HARNESS BETWEEN INVERTER UNIT AND AC 120V OUTLET MAIN SWITCH

1. Disconnect inverter unit connector R10.
2. Check for continuity between the inverter unit connector R10 terminal 1 and AC 120V outlet main switch connector M5 terminal 1.

Inverter unit		AC 120V outlet main switch		Continuity
Connector	Terminal	Connector	Terminal	
R10	1	M5	1	Yes

3. Check for continuity between inverter unit connector R10 terminal 1 and ground.

Inverter unit		Ground	Continuity
Connector	Terminal		
R10	1	—	No

Is the inspection result normal?

- YES >> Inspection End.  
NO >> Repair or replace the AC 120V outlet main switch input signal circuit.

### Component Inspection (AC 120V Outlet Main Switch)

INFOID:000000006928486

### 1. CHECK AC 120V OUTLET MAIN SWITCH

1. Turn ignition switch OFF.
2. Disconnect AC 120V outlet main switch connector.
3. Check continuity between terminals 1 and 2 of AC 120V outlet main switch.



# AC 120 V OUTLET MAIN SWITCH INPUT SIGNAL CIRCUIT

< DTC/CIRCUIT DIAGNOSIS >

[AC 120 V OUTLET]

AC 120V outlet main switch terminals	Condition	Continuity
1-2	AC 120V outlet main switch ON	Yes
	AC 120V outlet main switch OFF	No

Is the inspection result normal?

YES >> Inspection End.

NO >> Replace AC 120V outlet main switch.

A

B

C

D

E

F

G

H

I

J

K

L

PWO

N

O

P

# AC 120 V POWER OUTPUT CIRCUIT

< DTC/CIRCUIT DIAGNOSIS >

[AC 120 V OUTLET]

## AC 120 V POWER OUTPUT CIRCUIT

### Diagnosis Procedure

INFOID:000000006928487

Regarding Wiring Diagram information, refer to [PWO-20. "Wiring Diagram"](#).

### 1. CHECK HARNESS BETWEEN INVERTER UNIT AND AC 120V OUTLET

1. Turn ignition switch OFF.
2. Disconnect inverter unit connector R10, AC 120V outlet front connector and AC 120V outlet rear connector.
3. Check continuity between inverter unit connector R10 terminals 5, 11 and AC 120V outlet front connector B352 terminals 1, 4.

Inverter unit		AC 120V outlet front		Continuity
Connector	Terminal	Connector	Terminal	
R10	5	B352	1	Yes
	11		4	

4. Check continuity between inverter unit connector R10 terminals 5, 11 and AC 120V outlet rear connector R12 terminals 1, 4.

Inverter unit		AC 120V outlet rear		Continuity
Connector	Terminal	Connector	Terminal	
R10	5	R12	1	Yes
	11		4	

5. Check continuity between inverter unit connector R10 terminals 5, 11 and ground.

Inverter unit		Ground	Continuity
Connector	Terminal		
R10	5	—	No
	11		

6. Check continuity between inverter unit connector R10 terminals 5 and 11.

Inverter unit			Continuity
Connector	Terminal		
R10	5	11	No

Is the inspection result normal?

YES >> GO TO 2.

NO >> Repair or replace the harness or connectors.

### 2. CHECK INVERTER UNIT OUTPUT SIGNAL

1. Connect inverter unit connector R10, AC 120V outlet front connector and AC 120V outlet rear connector.
2. Turn ignition switch ON.
3. AC 120V outlet main switch ON (AC 120V outlet main switch 150W indicator ON).
4. Check voltage between inverter unit connector R10 terminals 5 and 11.

#### **CAUTION:**

- To measure AC 120V output signal, always use the circuit tester AC range.
- Never allow the probes to contact each other.

# AC 120 V POWER OUTPUT CIRCUIT

< DTC/CIRCUIT DIAGNOSIS >

[AC 120 V OUTLET]

Terminals		Condition	Voltage (Approx.)
(+)	(-)		
Inverter unit connector R10		AC 120V outlet main switch	
Terminal			
5	11	All indicators OFF	0V
		150W indicator ON	AC 120V

Is the inspection result normal?

- YES >> GO TO 3  
 NO >> Replace inverter unit.

### 3. CHECK AC 120V OUTLET FRONT VOLTAGE

1. AC 120V outlet main switch ON (AC 120V outlet main switch 150W indicator ON).
2. Check voltage between AC 120V outlet front B352 terminals 1 and 4.

**CAUTION:**

- To measure AC 120V output signal, always use the circuit tester AC range.
- Never allow the probes to contact each other.

Terminals		Condition	Voltage (Approx.)
(+)	(-)		
AC 120V outlet front connector B352		AC 120V outlet main switch	
Terminal			
1	4	OFF	0V
		ON	AC 120V

Is the inspection result normal?

- YES >> GO TO 4  
 NO >> Replace AC 120V outlet front.

### 4. CHECK AC 120V OUTLET FRONT GROUND CIRCUIT

1. AC 120V outlet main switch OFF.
2. Turn ignition switch OFF.
3. Disconnect AC 120V outlet front connector.
4. Check continuity between AC 120V outlet front connector B352 terminal 3 and ground.

AC 120V outlet front		Ground	Continuity
Connector	Terminal		
B352	3	—	Yes

Is the inspection result normal?

- YES >> GO TO 5  
 NO >> Repair AC 120V outlet front ground circuit.

### 5. CHECK AC 120V OUTLET REAR VOLTAGE

1. Turn ignition switch ON.
2. AC 120V outlet main switch ON (AC 120V outlet main switch 150W indicator ON).
3. Check voltage between AC 120V outlet rear R12 terminals 1 and 4.

**CAUTION:**

- To measure AC 120V output signal, always use the circuit tester AC range.
- Never allow the probes to contact each other.

# AC 120 V POWER OUTPUT CIRCUIT

< DTC/CIRCUIT DIAGNOSIS >

[AC 120 V OUTLET]

Terminals		Condition	Voltage (Approx.)
(+)	(-)		
AC 120V outlet front connector R12		AC 120V outlet main switch	
Terminal			
1	4	OFF	0V
		ON	AC 120V

Is the inspection result normal?

YES >> GO TO 6

NO >> Replace AC 120V outlet rear.

## 6. CHECK AC 120V OUTLET FRONT GROUND CIRCUIT

1. AC 120V outlet main switch OFF.
2. Turn ignition switch OFF.
3. Disconnect AC 120V outlet rear connector.
4. Check continuity between AC 120V outlet rear connector R12 terminal 3 and ground.

AC 120V outlet rear		Ground	Continuity
Connector	Terminal		
R12	3	—	Yes

Is the inspection result normal?

YES >> Inspection End.

NO >> Repair AC 120V outlet rear ground circuit.

# AC 120 V OUTLET MAIN SWITCH INDICATOR CIRCUIT

< DTC/CIRCUIT DIAGNOSIS >

[AC 120 V OUTLET]

## AC 120 V OUTLET MAIN SWITCH INDICATOR CIRCUIT

### Diagnosis Procedure (150W Indicator)

INFOID:000000006928488

Regarding Wiring Diagram information, refer to [PWO-20, "Wiring Diagram"](#).

#### 1. CHECK POWER SUPPLY FOR AC 120V OUTLET MAIN SWITCH INDICATOR

1. Turn ignition switch ON.
2. Check for voltage between the AC 120V outlet main switch connector M5 terminal 6 and ground.

AC 120V outlet main switch		Ground	Condition	Voltage (Approx.)
Connector	Terminal			
M5	6	—	Ignition switch ON	Battery voltage
			Ignition switch OFF	0V

Is the inspection result normal?

YES >> GO TO 2.

NO >> Repair or replace the AC 120V outlet main switch indicator power supply circuit.

#### 2. CHECK AC 120V OUTLET MAIN SWITCH 150W INDICATOR GROUND CIRCUIT

1. Turn ignition switch OFF.
2. Disconnect AC 120V outlet main switch connector and inverter unit connector R10.
3. Check continuity between AC 120V outlet main switch connector M5 terminal 7 and inverter unit connector R10 terminal 7.

AC 120V outlet main switch		Inverter unit		Continuity
Connector	Terminal	Connector	Terminal	
M5	7	R10	7	Yes

Is the inspection result normal?

YES >> Replace AC 120V outlet main switch.

NO >> Repair or replace the AC 120V outlet main switch 150W indicator ground circuit.

### Diagnosis Procedure (400W Indicator)

INFOID:000000007016744

Regarding Wiring Diagram information, refer to [PWO-20, "Wiring Diagram"](#).

#### 1. CHECK AC 120V OUTLET MAIN SWITCH INDICATORS

Check AC 120V outlet main switch indicators. Refer to [PWO-38, "Component Inspection \(AC 120V Outlet Main Switch Indicators\)"](#).

Is the inspection result normal?

YES >> GO TO 2.

NO >> Replace AC 120V outlet main switch.

#### 2. CHECK POWER SUPPLY FOR AC 120V OUTLET MAIN SWITCH INDICATOR

1. Turn ignition switch ON.
2. Check for voltage between the AC 120V outlet main switch connector M5 terminal 6 and ground.

AC 120V outlet main switch		Ground	Condition	Voltage (Approx.)
Connector	Terminal			

A  
B  
C  
D  
E  
F  
G  
H  
I  
J  
K  
L  
N  
O  
P

PWO

# AC 120 V OUTLET MAIN SWITCH INDICATOR CIRCUIT

< DTC/CIRCUIT DIAGNOSIS >

[AC 120 V OUTLET]

M5	6	—	Ignition switch ON	Battery voltage
			Ignition switch OFF	0V

Is the inspection result normal?

YES >> GO TO 3.

NO >> Repair or replace the AC 120V outlet main switch indicator power supply circuit.

## 3.CHECK AC 120V OUTLET MAIN SWITCH 400W INDICATOR GROUND CIRCUIT

1. Turn ignition switch OFF.
2. Disconnect AC 120V outlet main switch connector and inverter unit connector R10.
3. Check continuity between AC 120V outlet main switch connector M5 terminal 3 and inverter unit connector R10 terminal 3.

AC 120V outlet main switch		Inverter unit		Continuity
Connector	Terminal	Connector	Terminal	
M5	3	R10	3	Yes

Is the inspection result normal?

YES >> GO TO 4.

NO >> Repair or replace the AC 120V outlet main switch 400W indicator ground circuit.

## 4.CHECK A/T SHIFT SELECTOR

Check A/T shift selector. Refer to [PWO-39, "Component Inspections \(A/T Shift Selector\)"](#).

Is the inspection result normal?

YES >> GO TO 5.

NO >> Replace A/T shift selector.

## 5.CHECK P RANGE SWITCH SIGNAL CIRCUIT

1. Turn ignition switch OFF.
2. Disconnect A/T shift selector connector.
3. Check continuity between A/T shift selector connector M68 terminal 8 and inverter unit connector R10 terminal 6.

A/T shift selector		Inverter unit		Continuity
Connector	Terminal	Connector	Terminal	
M68	8	R10	6	Yes

Is the inspection result normal?

YES >> GO TO 6.

NO >> Repair or replace the P range switch signal circuit.

## 6.CHECK A/T SHIFT SELECTOR GROUND CIRCUIT

Check continuity between A/T shift selector connector M68 terminal 1 and ground.

A/T shift selector		Ground	Continuity
Connector	Terminal		
M68	1	—	Yes

Is the inspection result normal?

YES >> Replace inverter unit.

NO >> Repair or replace the A/T shift selector ground circuit.

## Component Inspection (AC 120V Outlet Main Switch Indicators)

INFOID:000000007016745

## 1.CHECK AC 120V OUTLET MAIN SWITCH INDICATORS

1. Turn ignition switch OFF.
2. Disconnect AC 120V outlet main switch connector.

# AC 120 V OUTLET MAIN SWITCH INDICATOR CIRCUIT

< DTC/CIRCUIT DIAGNOSIS >

[AC 120 V OUTLET]

3. Apply battery voltage to AC 120V outlet main switch terminal 6 and ground to terminal 7.

AC 120V outlet main switch terminals	Condition	150W indicator
6 – 7	Battery voltage applied to terminal 6 and ground to terminal 7	ON
	Voltage and ground removed	OFF

4. Apply battery voltage to AC 120V outlet main switch terminal 6 and ground to terminal 3.

AC 120V outlet main switch terminals	Condition	400W indicator
6 – 3	Battery voltage applied to terminal 6 and ground to terminal 3	ON
	Voltage and ground removed	OFF

Is the inspection result normal?

- YES >> Inspection End.  
NO >> Replace AC 120V outlet main switch.

## Component Inspections (A/T Shift Selector)

INFOID:000000007016746

### 1.CHECK A/T SHIFT SELECTOR

1. Turn ignition switch OFF.
2. Disconnect A/T shift selector connector.
3. Check continuity between terminals of the A/T shift selector.

A/T shift selector terminals	Condition	Continuity
8 – 1	Selector lever in "P" position.	Yes
	Selector lever not in "P" position.	No

Is the inspection result normal?

- YES >> Inspection End.  
NO >> Replace A/T shift selector.

A  
B  
C  
D  
E  
F  
G  
H  
I  
J  
K  
L  
N  
O  
P

PWO

## SYMPTOM DIAGNOSIS

### NO OUTPUT FROM AC 120 V OUTLET

#### Diagnosis Procedure

INFOID:000000006928489

#### 1. CHECK FAIL-SAFE ACTIVATION

---

Check if the symptom is caused by a fail-safe operation. Refer to [PWO-18, "Fail-safe"](#).

Is fail-safe operating?

YES >> Repair the part causing fail-safe operation.

NO >> GO TO 2.

#### 2. CHECK INVERTER UNIT POWER SUPPLY CIRCUIT

---

Check inverter unit power supply circuit. Refer to [PWO-28, "Diagnosis Procedure"](#).

Is the inspection result normal?

YES >> GO TO 3.

NO >> Repair or replace the malfunctioning parts.

#### 3. CHECK AC 120V OUTLET MAIN SWITCH POWER SUPPLY CIRCUIT

---

Check AC 120V outlet main switch power supply circuit. Refer to [PWO-31, "Diagnosis Procedure"](#).

Is the inspection result normal?

YES >> GO TO 4.

NO >> Repair or replace the malfunctioning parts.

#### 4. CHECK AC 120V OUTLET MAIN SWITCH INPUT SIGNAL CIRCUIT

---

Check AC 120V outlet main switch input signal circuit. Refer to [PWO-32, "Diagnosis Procedure"](#).

Is the inspection result normal?

YES >> GO TO 5.

NO >> Repair or replace the malfunctioning parts.

#### 5. CHECK INVERTER UNIT POWER OUTPUT CIRCUIT

---

Check inverter unit power output circuit. Refer to [PWO-34, "Diagnosis Procedure"](#).

Is the inspection result normal?

YES >> Refer to [GI-39, "Intermittent Incident"](#).

NO >> Repair or replace the malfunctioning parts.



# AC 120 V OUTLET MAIN SWITCH INDICATOR DOES NOT TURN ON

< SYMPTOM DIAGNOSIS >

[AC 120 V OUTLET]

## AC 120 V OUTLET MAIN SWITCH INDICATOR DOES NOT TURN ON

### Diagnosis Procedure

INFOID:000000006928490

#### 1. CHECK FAIL-SAFE ACTIVATION

Check if the symptom is caused by a fail-safe operation. Refer to [PWO-18, "Fail-safe"](#).

Is fail-safe operating?

- YES >> Repair the part causing fail-safe operation.
- NO >> GO TO 2.

#### 2. CHECK INVERTER UNIT POWER SUPPLY CIRCUIT

Check inverter unit power supply circuit. Refer to [PWO-28, "Diagnosis Procedure"](#).

Is the inspection result normal?

- YES >> GO TO 3.
- NO >> Repair or replace the malfunctioning parts.

#### 3. CHECK AC 120V OUTLET MAIN SWITCH POWER SUPPLY CIRCUIT

Check AC 120V outlet main switch power supply circuit. Refer to [PWO-31, "Diagnosis Procedure"](#).

Is the inspection result normal?

- YES >> GO TO 4.
- NO >> Repair or replace the malfunctioning parts.

#### 4. CHECK AC 120V OUTLET MAIN SWITCH INPUT SIGNAL CIRCUIT

Check AC 120V outlet main switch input signal circuit. Refer to [PWO-32, "Diagnosis Procedure"](#).

Is the inspection result normal?

- YES >> GO TO 5.
- NO >> Repair or replace the malfunctioning parts.

#### 5. CHECK AC 120V OUTLET MAIN SWITCH INDICATOR CIRCUIT

Check AC 120V outlet main switch indicator circuit. Refer to [PWO-37, "Diagnosis Procedure \(150W Indicator\)"](#).

Is the inspection result normal?

- YES >> Refer to [GI-39, "Intermittent Incident"](#).
- NO >> Repair or replace the malfunctioning parts.

A  
B  
C  
D  
E  
F  
G  
H  
I  
J  
K  
L  
N  
O  
P

PWO

## NORMAL OPERATING CONDITION

### Description

INFOID:000000006928491

Because of modified sine wave output, the AC 120V outlet may not operate normally for electric appliance of which electric power consumption is 150W or less.

- Electric appliances requiring a large amount of electric power consumption at startup (e.g., CRT-based TV, power tool)
- Measuring instruments for data requiring accuracy (e.g., medical equipment, measuring instrument)
- Microprocessor-controlled appliances (e.g., microprocessor-controlled blanket)

Noise may be caused in radio or TV, depending on an electric appliance.

# INVERTER UNIT

< REMOVAL AND INSTALLATION >

[AC 120 V OUTLET]

## REMOVAL AND INSTALLATION

### INVERTER UNIT

#### Removal and Installation

INFOID:000000006928492

#### REMOVAL

1. Remove the inverter unit fuse.
2. Remove rear lower finisher LH (if equipped). Refer to [INT-39. "REAR SIDE REAR FINISHER : Removal and Installation - Rear Lower Finisher LH \(Cargo Van\)"](#) (Cargo Van) or [INT-43. "REAR SIDE REAR FINISHER : Removal and Installation - Rear Lower Finisher LH \(Passenger Van\)"](#) (Passenger Van).

3. Remove the ground bolt (A).

⇐: Front

4. Release the harness clip (B).

5. Remove the inverter unit bracket to body bolts (C), then pull the inverter unit (1) outward.

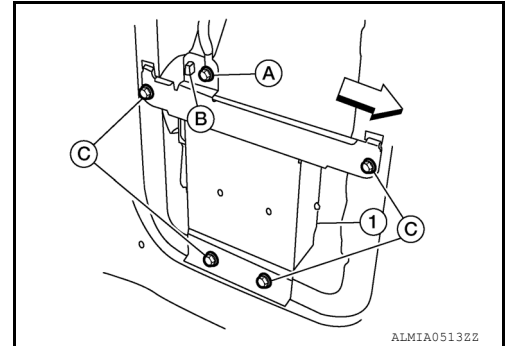

6. Disconnect the harness connectors (B) from the inverter unit and remove.

⇐: Front

7. Remove the inverter unit bracket bolts (A), then remove the inverter unit brackets from the inverter unit.

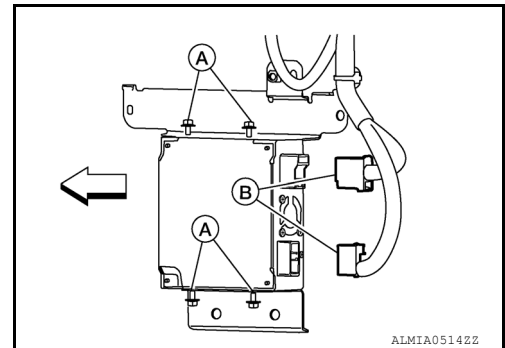

#### INSTALLATION

Installation is in the reverse order of removal.

A

B

C

D

E

F

G

H

I

J

K

L

PWO

N

O

P

# AC 120V OUTLET MAIN SW

< REMOVAL AND INSTALLATION >

[AC 120 V OUTLET]

## AC 120V OUTLET MAIN SW

### Removal and Installation

INFOID:000000006928493

#### REMOVAL

1. Remove the inverter unit fuse.
2. Beginning on the RH side of the instrument panel switch carrier, release the metal clips and pawls using a suitable tool (A), then reposition the instrument panel switch carrier.

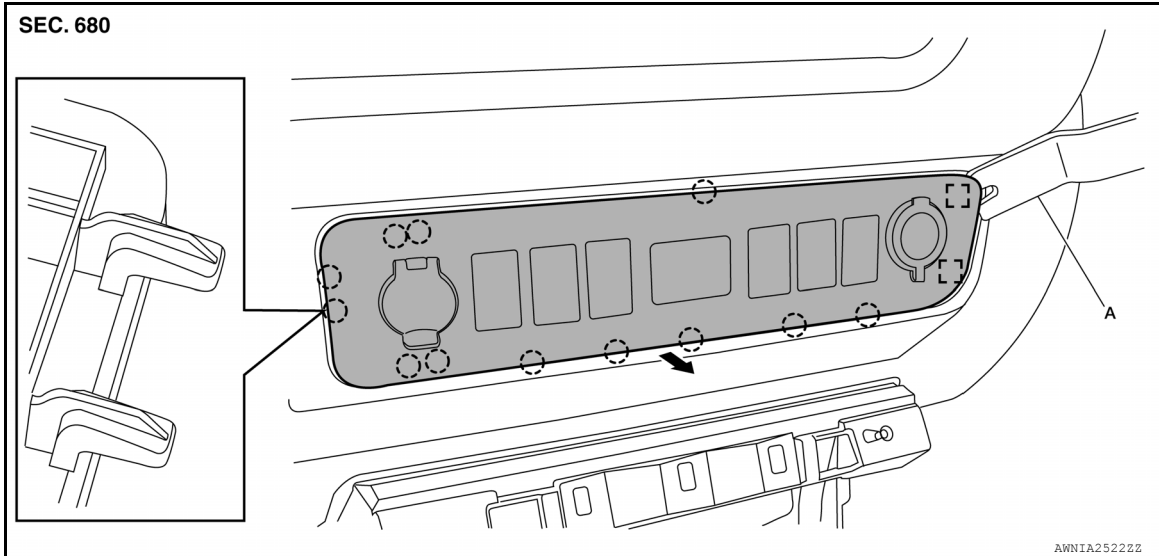

- ☐: Metal clip
- : Pawl

3. Disconnect the harness connector (1) from the AC 120V outlet main switch.
4. Release the pawls using a suitable tool (A), then remove the AC 120V outlet main switch (3) from instrument panel switch carrier (2).

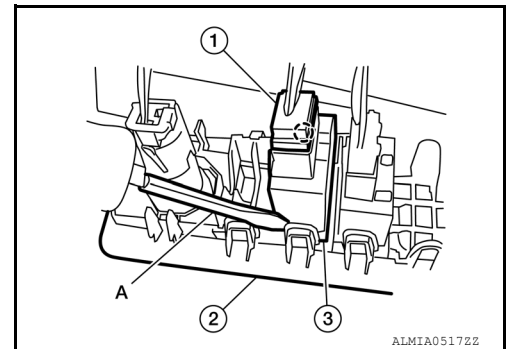

#### INSTALLATION

Installation is in the reverse order of removal.

# AC 120 V OUTLET

< REMOVAL AND INSTALLATION >

[AC 120 V OUTLET]

## AC 120 V OUTLET

### Removal and Installation

INFOID:000000006928494

#### AC 120V OUTLET FRONT

##### Removal

1. Remove the inverter unit fuse.
2. Remove the outlet panel finisher (1). Refer to [IP-26, "Disassembly and Assembly"](#).
3. From the back, release the pawls (A) by pressing inward, then push the AC 120V outlet front (2) through the outlet panel finisher (1).

○: Pawl

4. Disconnect the harness connector from the AC 120V outlet.
5. Remove the AC 120V outlet front (2).

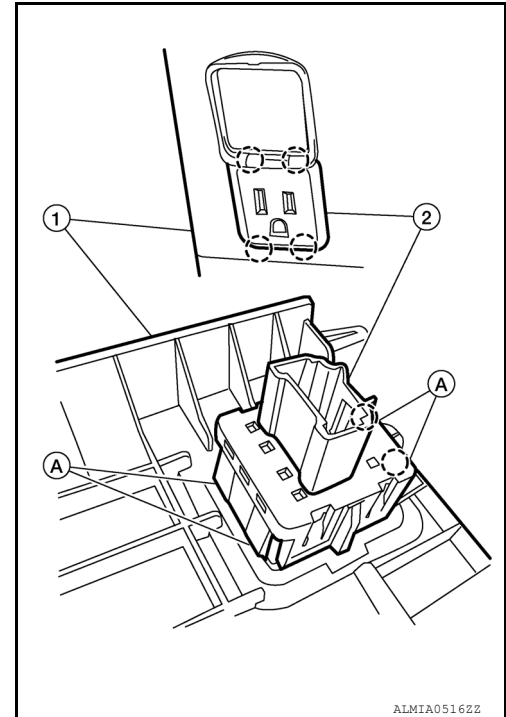

##### Installation

Installation is in the reverse order of removal.

#### AC 120V OUTLET REAR

##### Removal

1. Remove the inverter unit fuse.
2. Remove the rear lower finisher LH. Refer to [INT-39, "REAR SIDE REAR FINISHER : Removal and Installation - Rear Lower Finisher LH \(Cargo Van\)"](#) (Cargo Van) or [INT-43, "REAR SIDE REAR FINISHER : Removal and Installation - Rear Lower Finisher LH \(Passenger Van\)"](#) (Passenger Van).
3. Release the pawls then pull the AC 120V outlet rear (1) from the rear lower finisher LH.

○: Pawl

4. Disconnect the harness connector from the AC 120V outlet.
5. Remove the AC 120V outlet rear (1).

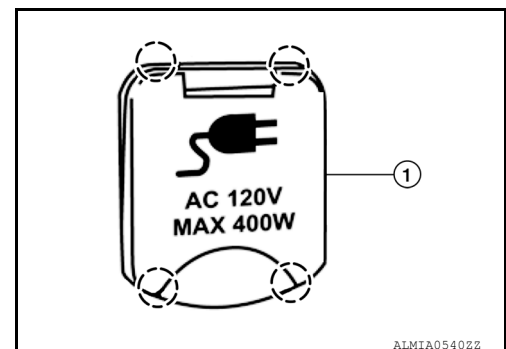

##### Installation

Installation is in the reverse order of removal.

A  
B  
C  
D  
E  
F  
G  
H  
I  
J  
K  
L  
PWO  
N  
O  
P

# SERVICE DATA AND SPECIFICATIONS (SDS)

< SERVICE DATA AND SPECIFICATIONS (SDS)

[AC 120 V OUTLET]

## SERVICE DATA AND SPECIFICATIONS (SDS)

### SERVICE DATA AND SPECIFICATIONS (SDS)

#### AC 120V Outlet

INFOID:000000006928495

Rated voltage output		AC 120V (+/- 10%)
Operating voltage range		DC 11.5V to 15V (Inverter terminal)
Rated power output	Low power mode	150W
	High power mode	400W
Output over current protection	High power mode	3.7A or more
Input over current protection	Low power mode	13.3A or more
Output frequency		60Hz (+/- 10%)
Parasitic current		< 1mA
Max. input current		45A (during continuous power)
Rated continuous power		400W @ 40°C (104°F) Maximum
Overheat protection (Thermistor)		100°C (212°F)