

A
B
C

SECTION **PB**

PARKING BRAKE SYSTEM

CONTENTS

<p>PRECAUTION 2</p> <p>PRECAUTIONS 2</p> <p style="padding-left: 20px;">Precaution for Supplemental Restraint System (SRS) "AIR BAG" and "SEAT BELT PRE-TENSIONER"2</p> <p>PREPARATION 3</p> <p>PREPARATION 3</p> <p style="padding-left: 20px;">Commercial Service Tool3</p> <p>PERIODIC MAINTENANCE 4</p> <p>PARKING BRAKE SYSTEM 4</p> <p style="padding-left: 20px;">Inspection and Adjustment4</p>	<p>REMOVAL AND INSTALLATION 6</p> <p>PARKING BRAKE CONTROL 6</p> <p style="padding-left: 20px;">Exploded View 6</p> <p style="padding-left: 20px;">Removal and Installation 6</p> <p>PARKING BRAKE SHOE 8</p> <p style="padding-left: 20px;">Exploded View 8</p> <p style="padding-left: 20px;">Removal and Installation 8</p> <p>SERVICE DATA AND SPECIFICATIONS (SDS)12</p> <p>SERVICE DATA AND SPECIFICATIONS (SDS)12</p> <p style="padding-left: 20px;">Parking Brake Drum and Shoes12</p> <p style="padding-left: 20px;">Parking Brake Control12</p>
---	--

PB

D
E
F
G
H
I
J
K
L
M
N
O
P

PRECAUTIONS

< PRECAUTION >

PRECAUTION

PRECAUTIONS

Precaution for Supplemental Restraint System (SRS) "AIR BAG" and "SEAT BELT PRE-TENSIONER"

INFOID:000000012521943

The Supplemental Restraint System such as "AIR BAG" and "SEAT BELT PRE-TENSIONER", used along with a front seat belt, helps to reduce the risk or severity of injury to the driver and front passenger for certain types of collision. This system includes seat belt switch inputs and dual stage front air bag modules. The SRS system uses the seat belt switches to determine the front air bag deployment, and may only deploy one front air bag, depending on the severity of a collision and whether the front occupants are belted or unbelted. Information necessary to service the system safely is included in the SR and SB section of this Service Manual.

WARNING:

- To avoid rendering the SRS inoperative, which could increase the risk of personal injury or death in the event of a collision which would result in air bag inflation, all maintenance must be performed by an authorized NISSAN/INFINITI dealer.
- Improper maintenance, including incorrect removal and installation of the SRS, can lead to personal injury caused by unintentional activation of the system. For removal of Spiral Cable and Air Bag Module, see the SR section.
- Do not use electrical test equipment on any circuit related to the SRS unless instructed to in this Service Manual. SRS wiring harnesses can be identified by yellow and/or orange harnesses or harness connectors.

PRECAUTIONS WHEN USING POWER TOOLS (AIR OR ELECTRIC) AND HAMMERS

WARNING:

- When working near the Airbag Diagnosis Sensor Unit or other Airbag System sensors with the Ignition ON or engine running, DO NOT use air or electric power tools or strike near the sensor(s) with a hammer. Heavy vibration could activate the sensor(s) and deploy the air bag(s), possibly causing serious injury.
- When using air or electric power tools or hammers, always switch the Ignition OFF, disconnect the battery and wait at least three minutes before performing any service.

PREPARATION



< PREPARATION >

PREPARATION

PREPARATION

Commercial Service Tool

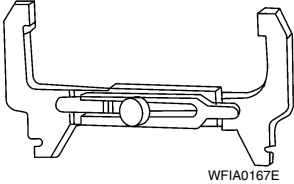
INFOID:0000000012521944

Tool name	Description
Brake drum clearance gauge  WFIA0167E	Measuring rear rotor drum inner diameter
Power tool  PIIB1407E	Loosening nuts, screws and bolts

A

B

C

D

E

PB

G

H

I

J

K

L

M

N

O

P

PARKING BRAKE SYSTEM

< PERIODIC MAINTENANCE >

PERIODIC MAINTENANCE

PARKING BRAKE SYSTEM

Inspection and Adjustment

INFOID:000000012521945

INSPECTION

Pedal Stroke

- When parking brake pedal is operated with the specified force, make sure the pedal stroke is within the specified number of notches. (Check by listening and counting the ratchet clicks).

Pedal stroke : Refer to [PB-12, "Parking Brake Control"](#).

- When brake warning lamp turns ON, check that the pedal stroke is within the specified number of notches. (Check by listening and counting the ratchet clicks).

Pedal stroke : Refer to [PB-12, "Parking Brake Control"](#).

Components

Check the following items and replace if necessary.

- Check that each component is attached properly, checking for looseness and backlash.
- Check parking brake pedal assembly for bends, damage and cracks.
- Check the parking brake cables and equalizer for wear and damage.
- Check parking brake warning lamp switch for malfunction. Refer to [BRC-11, "Parking Brake Switch"](#).

ADJUSTMENT

1. Partially engage parking brake pedal to access the adjusting nut.
2. Insert a deep socket wrench to rotate the adjusting nut and loosen the parking brake cable sufficiently.
3. Disengage the parking brake pedal.
4. Adjust parking brake shoe to drum clearance.
 - Remove access plug from backside of the backing plate.
 - Rotate adjuster in the direction shown until the drum locks, using a suitable tool.
 - Rotate adjuster opposite the direction shown 14 - 15 teeth to set total shoe center clearance, using a suitable tool.
 - A: For RH parking brake
 - B: For LH parking brake
 - ⇐ : Front
 - ← : Adjuster expands

Total shoe center clearance : 0.70 - 0.74 mm (0.028 - 0.029 in)

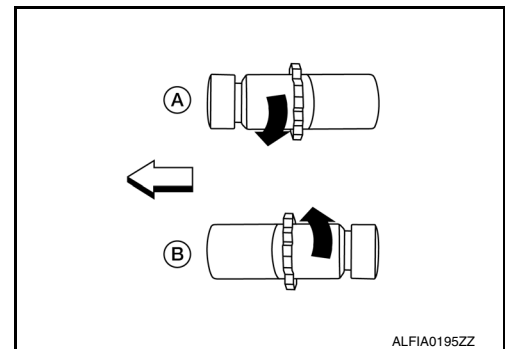

5. Rotate the disc rotor to check that there is no drag. If any drag is found, perform the following.
 - a. Check that the parking brake cable is sufficiently loose.
 - b. Check the rear disc brake. Refer to [BR-20, "BRAKE PAD : Inspection and Adjustment"](#).
6. Install the access plug to the backing plate.
7. Adjust the cable as follows:
 - a. Temporarily adjust the cable so that the parking brake pedal operating force immediately before the full pedal stroke reaches 500 N (51.0 kg-f, 112.4 lb-f) or more.
 - b. Operate the parking brake pedal with a force of 500 N (51.0 kg-f, 112.4 lb-f) for 2 strokes or more.
 - c. Maintain the parking brake pedal at 500 N (51.0 kg-f, 112.4 lb-f) for 48 minutes or more.
 - b. Adjust the parking brake pedal stroke by turning the adjusting nut so the operating force is within the specified number of notches. (Check it by listening and counting the ratchet clicks).

CAUTION:

Do not reuse the adjusting nut if the nut is removed.

Pedal stroke : Refer to [PB-12, "Parking Brake Control"](#).

PARKING BRAKE SYSTEM

< PERIODIC MAINTENANCE >

8. Rotate the disc rotor to check that there is no drag. If any drag is found, perform the following.
 - a. Adjust the parking brake pedal stroke again.
 - b. Check the rear disc brake. Refer to [BR-20. "BRAKE PAD : Inspection and Adjustment"](#).

A

B

C

D

E

PB

G

H

I

J

K

L

M

N

O

P

PARKING BRAKE CONTROL

< REMOVAL AND INSTALLATION >

REMOVAL AND INSTALLATION

PARKING BRAKE CONTROL

Exploded View

INFOID:000000012521946

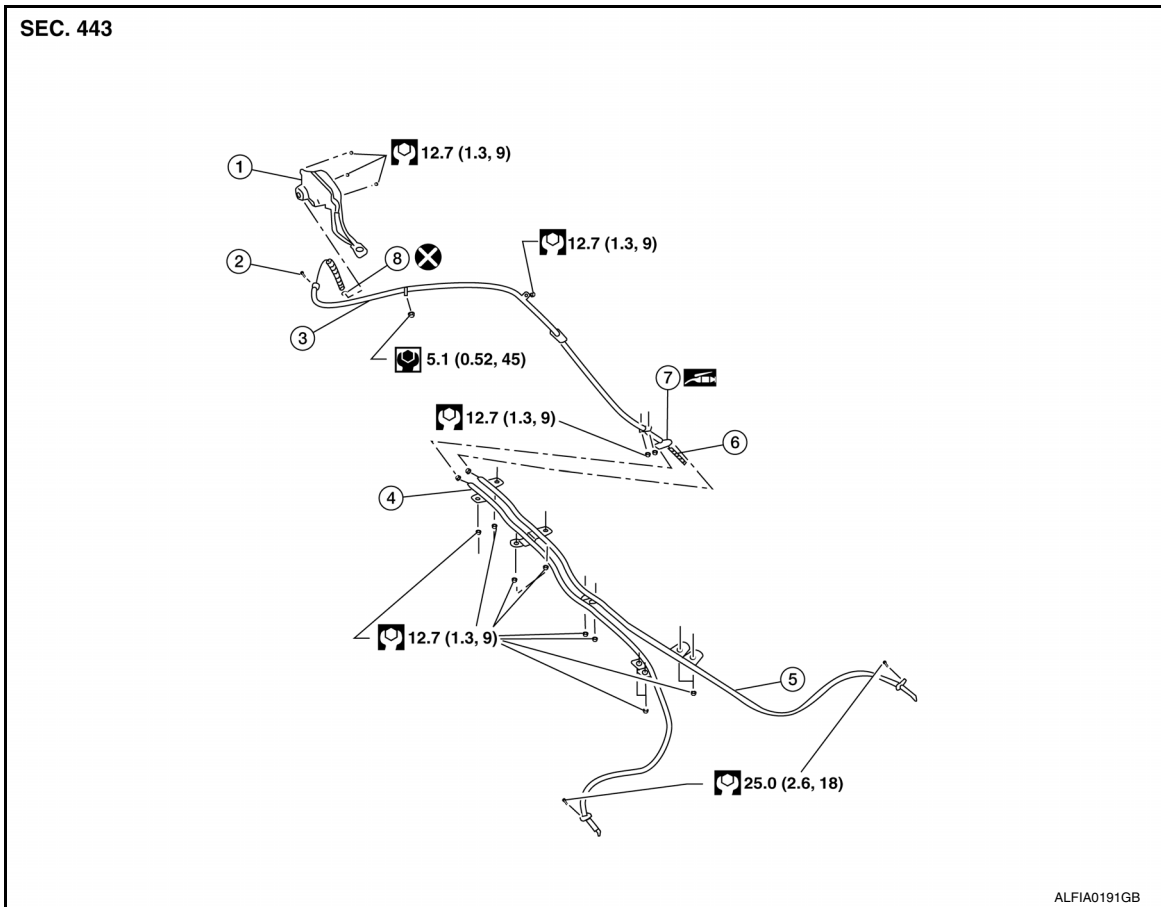

- | | | |
|----------------------------------|----------------------------------|------------------------------|
| 1. Parking brake pedal assembly | 2. Lock plate | 3. Front parking brake cable |
| 4. Rear parking brake cable (LH) | 5. Rear parking brake cable (RH) | 6. Return spring |
| 7. Equalizer | 8. Adjusting nut | |

Removal and Installation

INFOID:000000012521947

PARKING BRAKE PEDAL ASSEMBLY

Removal

1. Disconnect the parking brake warning lamp switch.
2. Remove the adjusting nut and discard.
CAUTION:
Do not reuse adjusting nut after removing it.
3. Remove the lock plate from the front parking brake cable.
4. Remove the parking brake pedal assembly nuts.
5. Position the parking brake pedal in the applied position to remove the front parking brake cable from the parking brake pedal assembly.
6. Remove the parking brake pedal assembly.

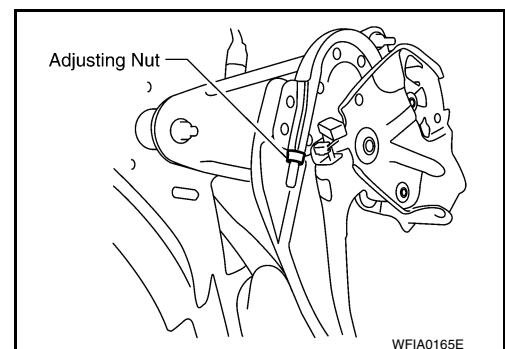

Installation

PARKING BRAKE CONTROL

< REMOVAL AND INSTALLATION >

Installation is in the reverse order of removal.

- Adjust the parking brake. Refer to [PB-4, "Inspection and Adjustment"](#).

CAUTION:

Do not reuse adjusting nut after removing it.

FRONT PARKING BRAKE CABLE

Removal

1. Remove the parking brake pedal assembly. Refer to PARKING BRAKE PEDAL ASSEMBLY. A
2. Remove the center console (if equipped). Refer to [IP-25, "Removal and Installation"](#). B
3. Remove the floor trim. Refer to [INT-44, "Removal and Installation - Cargo Van"](#). C
4. Remove the front parking brake cable nuts inside the vehicle. D
5. Disconnect the return spring from the equalizer. E
6. Disconnect rear parking brake cables from the equalizer. E
7. Remove the front parking brake cable nuts under the vehicle and remove the front parking brake cable from the vehicle. E

Installation

Installation is in the reverse order of removal.

- Adjust the parking brake. Refer to [PB-4, "Inspection and Adjustment"](#).

CAUTION:

Do not reuse adjusting nut after removing it.

REAR PARKING BRAKE CABLES

Removal

1. Remove the rear parking brake cable bolts at rear wheels. G
2. Remove the rear parking brake cable from the toggle lever. H
3. Remove the rear parking brake cables from the equalizer. I
4. Remove the rear parking brake cable retaining nuts, then remove the rear parking brake cables. J

Installation

Installation is in the reverse order of removal.

- Adjust the parking brake. Refer to [PB-4, "Inspection and Adjustment"](#). K

	L
	M
	N
	O
	P

PARKING BRAKE SHOE

< REMOVAL AND INSTALLATION >

PARKING BRAKE SHOE

Exploded View

INFOID:000000012521948

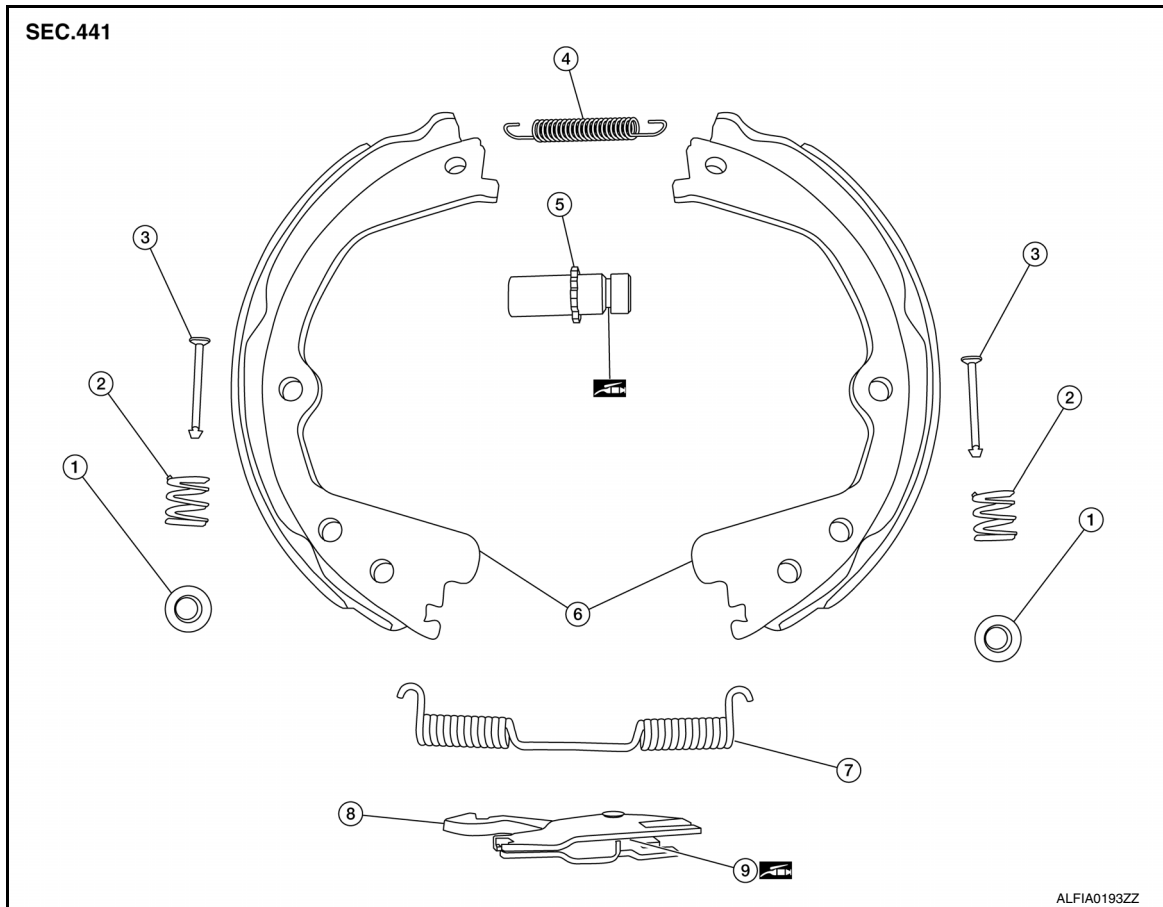

- | | | |
|------------------------|---------------------|------------------------|
| 1. Retainers | 2. Retainer springs | 3. Anti-rattle pins |
| 4. Upper return spring | 5. Adjuster | 6. Parking brake shoes |
| 7. Lower return spring | 8. Toggle lever | 9. Bushing |

 PBC (Poly Butyl Cuprysil) grease

Removal and Installation

INFOID:000000012521949

REMOVAL

WARNING:

Clean the brakes with a vacuum dust collector to minimize the hazard of airborne particles or other materials.

NOTE:

Remove the disc rotor only with the parking brake pedal completely in the released position.

1. Remove the rear disc rotor. Refer to [BR-39, "BRAKE CALIPER ASSEMBLY : Removal and Installation of Brake Caliper Assembly and Rotor"](#).
2. Remove the upper return spring.
3. Remove the adjuster.
4. Disconnect the rear parking brake cable from the toggle lever.

PARKING BRAKE SHOE

< REMOVAL AND INSTALLATION >

5. Using a suitable tool (A), pry gently in the direction shown to remove toggle lever.

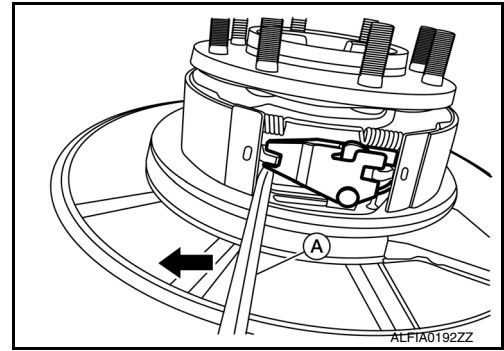

6. Using suitable tool remove the retainers, retainer springs, anti-rattle pins and parking brake shoes.
7. Remove the lower return spring from the parking brake shoes.

INSPECTION AFTER REMOVAL

Lining Thickness Inspection

- Check thickness (A) of lining.

Wear limit thickness (A) : Refer to [PB-12, "Parking Brake Drum and Shoes"](#).

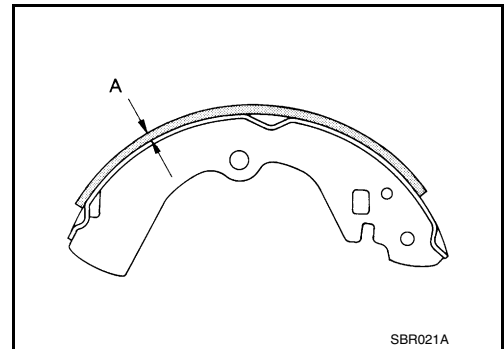

Disc Rotor Inner Diameter Inspection

- Check inner diameter (B) inside drum area of disc rotor, using a suitable tool.

Wear limit of inner diameter (B) : Refer to [PB-12, "Parking Brake Drum and Shoes"](#).

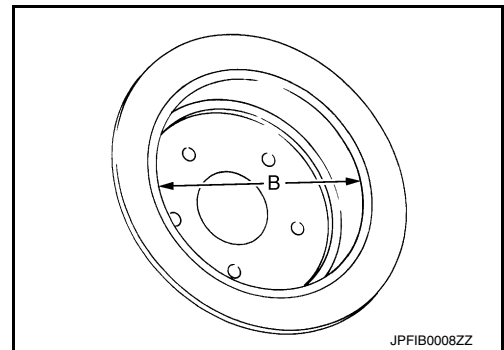

Other Inspections

- Check shoe sliding surface on back plate for excessive wear and damage.
- Check anti-rattle pins for excessive wear and corrosion.
- Check return springs for sagging.
- Check adjuster for rough operation.
- Check the toggle lever for excessive wear, damage and rust.
- When disassembling adjuster, apply PBC (Poly Butyl Cuprysil) grease or equivalent to the threads.
- Visually check inside the drum area of the disc rotor for cracks and damage.
- Check the inside of the drum for excessive wear with a vernier caliper.

INSTALLATION

PARKING BRAKE SHOE

< REMOVAL AND INSTALLATION >

1. Apply PBC (Poly Butyl Cuprysil) grease to the specified points during assembly.

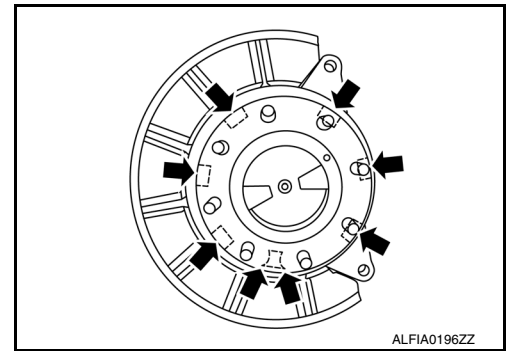

2. Install the front parking brake shoe (1) with the lower return spring (2) attached.

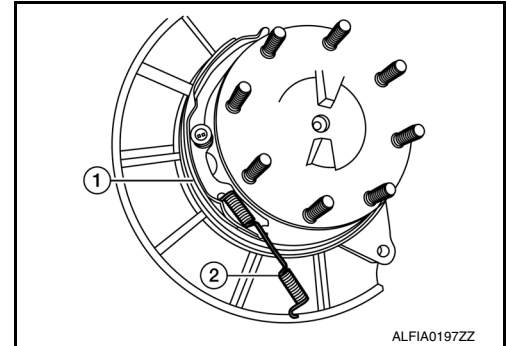

3. Install the rear parking brake shoe.
 - a. Install the lower return spring (1) onto the rear parking brake shoe (2) and hold the rear parking brake shoe in place using suitable tool (A) as shown.
 - b. Install the anti-rattle pin, retainer spring and retainer using suitable tool.
 - c. Remove suitable tool (A) from the rear parking brake shoe (2).

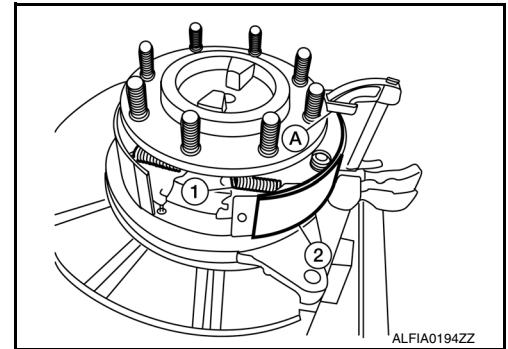

4. Using a suitable tool (A), pry gently in the direction shown to install the toggle lever.

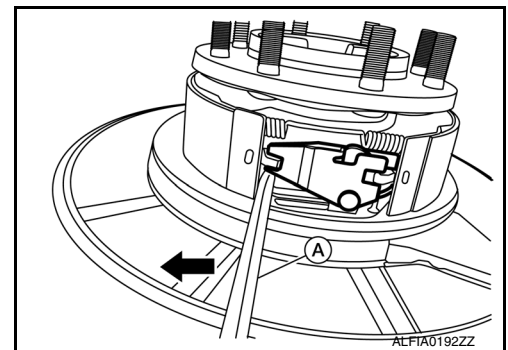

5. Install the adjuster.

PARKING BRAKE SHOE

< REMOVAL AND INSTALLATION >

- Install adjuster so that threaded part expands when rotating it in the direction shown.
- Shorten adjuster by rotating it opposite the direction shown.
- A: For RH parking brake
- B: For LH parking brake
- ⇐ : Front
- ◀ : Adjuster expands

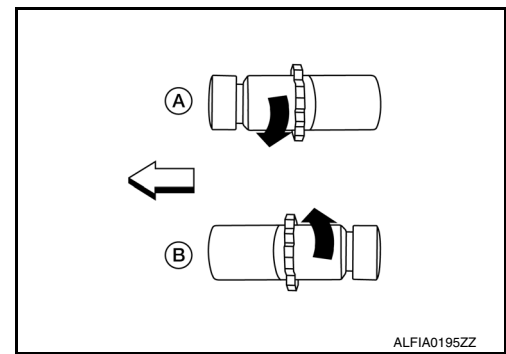

6. Install the upper return spring.
7. The remainder of installation is in the reverse order of removal.

ADJUSTMENT

NOTE:

After replacing brake shoes or disc rotors, or if brakes do not function well, perform break-in operation as follows.

1. Adjust parking brake pedal stroke. Refer to [PB-4. "Inspection and Adjustment"](#).
2. Perform parking brake break-in operation by driving the vehicle forward under the following conditions:
 - Vehicle speed at 40 ± 5 km/h (25 ± 3 MPH)
 - Apply parking brake pedal with an operating force of $250 +40, -0$ N ($25.5 +4.1, -0$ kg-f, $56.2 +9.0, -0$ lb-f)
 - Apply parking brake for a period of $15 +5, -0$ seconds

CAUTION:

- **To prevent lining from getting too hot, allow a cool off period of approximately 5 minutes after every break-in operation.**
 - **Do not perform excessive break-in operations, because it may cause uneven or early wear of lining.**
3. After break-in operation, check parking brake pedal stroke. Readjust if the parking brake pedal stroke is not within specification. Refer to [PB-4. "Inspection and Adjustment"](#).

SERVICE DATA AND SPECIFICATIONS (SDS)

< SERVICE DATA AND SPECIFICATIONS (SDS)

SERVICE DATA AND SPECIFICATIONS (SDS)

SERVICE DATA AND SPECIFICATIONS (SDS)

Parking Brake Drum and Shoes

INFOID:0000000012521950

Unit: mm (in)

Type		Disc rotor with inner drum
Brake lining	Wear limit thickness	1.0 (0.039)
Drum inner diameter (drum in disc)	Wear limit of inner diameter	227.7 (8.96)

Parking Brake Control

INFOID:0000000012521951

Control type		Foot pedal
Number of notches [under force of 196 N (20.0 kg-f, 44.1 lb-f)]		6 - 7 notches
Number of notches when brake warning lamp turns ON		1 notch