

**WT**  
**SECTION**  
**ROAD WHEELS & TIRES**

A  
B  
C  
D

WT

**CONTENTS**

<p><b>BASIC INSPECTION</b> ..... 3</p> <p><b>DIAGNOSIS AND REPAIR WORKFLOW</b> ..... 3</p> <p style="padding-left: 20px;">Repair Work Flow .....3</p> <p><b>INSPECTION AND ADJUSTMENT</b> ..... 5</p> <p style="padding-left: 20px;">Preliminary Check .....5</p> <p style="padding-left: 20px;">Transmitter Wake Up Operation .....5</p> <p style="padding-left: 20px;">ID Registration Procedure .....6</p> <p><b>SYSTEM DESCRIPTION</b> ..... 8</p> <p><b>TPMS</b> ..... 8</p> <p style="padding-left: 20px;">System Diagram .....8</p> <p style="padding-left: 20px;">System Description .....8</p> <p style="padding-left: 20px;">System Component .....10</p> <p><b>DIAGNOSIS SYSTEM (BCM)</b> .....11</p> <p style="padding-left: 20px;">CONSULT Function (BCM - COMMON ITEM) ..... 11</p> <p style="padding-left: 20px;">CONSULT Function (BCM - AIR PRESSURE MONITOR) .....12</p> <p style="padding-left: 20px;">Self-Diagnosis (Without CONSULT) .....12</p> <p><b>DTC/CIRCUIT DIAGNOSIS</b> .....14</p> <p><b>C1708 - C1711 DATA FROM TRANSMITTER NOT BEING RECEIVED</b> .....14</p> <p style="padding-left: 20px;">Description .....14</p> <p style="padding-left: 20px;">DTC Logic .....14</p> <p style="padding-left: 20px;">Diagnosis Procedure .....14</p> <p style="padding-left: 20px;">Special Repair Requirement .....15</p> <p><b>C1712 - C1715, C1720 - C1723, C1724 - C1727 TRANSMITTER MALFUNCTION</b> .....16</p> <p style="padding-left: 20px;">Description .....16</p> <p style="padding-left: 20px;">DTC Logic .....16</p> <p style="padding-left: 20px;">Diagnosis Procedure .....16</p> <p style="padding-left: 20px;">Special Repair Requirement .....17</p> <p><b>C1716 - C1719 TRANSMITTER PRESSURE MALFUNCTION</b> .....18</p> <p style="padding-left: 20px;">Description .....18</p>	<p style="padding-left: 20px;">DTC Logic .....18</p> <p style="padding-left: 20px;">Diagnosis Procedure .....18</p> <p style="padding-left: 20px;">Special Repair Requirement .....19</p> <p><b>C1729 VEHICLE SPEED SIGNAL</b> .....20</p> <p style="padding-left: 20px;">Description .....20</p> <p style="padding-left: 20px;">DTC Logic .....20</p> <p style="padding-left: 20px;">Diagnosis Procedure .....20</p> <p style="padding-left: 20px;">Special Repair Requirement .....20</p> <p><b>C1735 IGNITION SIGNAL</b> .....21</p> <p style="padding-left: 20px;">Description .....21</p> <p style="padding-left: 20px;">DTC Logic .....21</p> <p style="padding-left: 20px;">Diagnosis Procedure .....21</p> <p style="padding-left: 20px;">Special Repair Requirement .....22</p> <p><b>ECU DIAGNOSIS INFORMATION</b> .....23</p> <p><b>BCM (BODY CONTROL MODULE)</b> .....23</p> <p style="padding-left: 20px;">Reference Value .....23</p> <p style="padding-left: 20px;">Terminal Layout .....26</p> <p style="padding-left: 20px;">Physical Values .....26</p> <p style="padding-left: 20px;">Self-Diagnosis (With CONSULT) .....31</p> <p style="padding-left: 20px;">Self-Diagnosis (Without CONSULT) .....32</p> <p><b>WIRING DIAGRAM</b> .....34</p> <p><b>TIRE PRESSURE MONITORING SYSTEM</b> .....34</p> <p style="padding-left: 20px;">Wiring Diagram .....34</p> <p><b>SYMPTOM DIAGNOSIS</b> .....38</p> <p><b>TPMS</b> .....38</p> <p style="padding-left: 20px;">Symptom Table .....38</p> <p><b>LOW TIRE PRESSURE WARNING LAMP DOES NOT TURN ON</b> .....39</p> <p style="padding-left: 20px;">Low Tire Pressure Warning Lamp Does Not Come On When Ignition Switch Is Turned On .....39</p> <p><b>LOW TIRE PRESSURE WARNING LAMP STAYS ON</b> .....40</p>
---	--

F  
G  
H  
I  
J  
K  
L  
M  
N  
O  
P

Low Tire Pressure Warning Lamp Stays On When Ignition Switch Is Turned On .....	40	<b>PREPARATION</b> .....	47
<b>LOW TIRE PRESSURE WARNING LAMP BLINKS</b> .....	41	Special Service Tool .....	47
Low Tire Pressure Warning Lamp Flashes When Ignition Switch Is Turned On .....	41	Commercial Service Tool .....	47
<b>HAZARD WARNING LAMPS FLASH</b> .....	42	<b>SYMPTOM DIAGNOSIS</b> .....	48
Hazard Warning Lamps Flash When Ignition Switch Is Turned On .....	42	<b>NOISE, VIBRATION, AND HARSHNESS (NVH) TROUBLESHOOTING</b> .....	48
<b>"TIRE PRESSURE" INFORMATION IN DISPLAY UNIT DOES NOT EXIST</b> .....	43	NVH Troubleshooting Chart .....	48
"TIRE PRESSURE" Information in Display Unit Does Not Exist .....	43	<b>PERIODIC MAINTENANCE</b> .....	49
<b>ID REGISTRATION CANNOT BE COMPLETED</b> .....	44	<b>WHEEL</b> .....	49
ID Registration Cannot Be Completed .....	44	Inspection .....	49
<b>PRECAUTION</b> .....	45	<b>WHEEL AND TIRE ASSEMBLY</b> .....	50
<b>PRECAUTIONS</b> .....	45	Adjustment .....	50
Precaution for Supplemental Restraint System (SRS) "AIR BAG" and "SEAT BELT PRE-TENSIONER" .....	45	<b>REMOVAL AND INSTALLATION</b> .....	52
Precaution Necessary for Steering Wheel Rotation After Battery Disconnect .....	45	<b>REMOVAL AND INSTALLATION</b> .....	52
Precaution for Road Wheel .....	46	Exploded View .....	52
<b>PREPARATION</b> .....	47	Transmitter (Pressure Sensor) .....	52
		<b>SERVICE DATA AND SPECIFICATIONS (SDS)</b> .....	55
		<b>SERVICE DATA AND SPECIFICATIONS (SDS)</b> .....	55
		Road Wheel .....	55
		Tire .....	55

# DIAGNOSIS AND REPAIR WORKFLOW

< BASIC INSPECTION >

## BASIC INSPECTION

### DIAGNOSIS AND REPAIR WORKFLOW

Repair Work Flow

INFOID:000000007357032

WORK FLOW

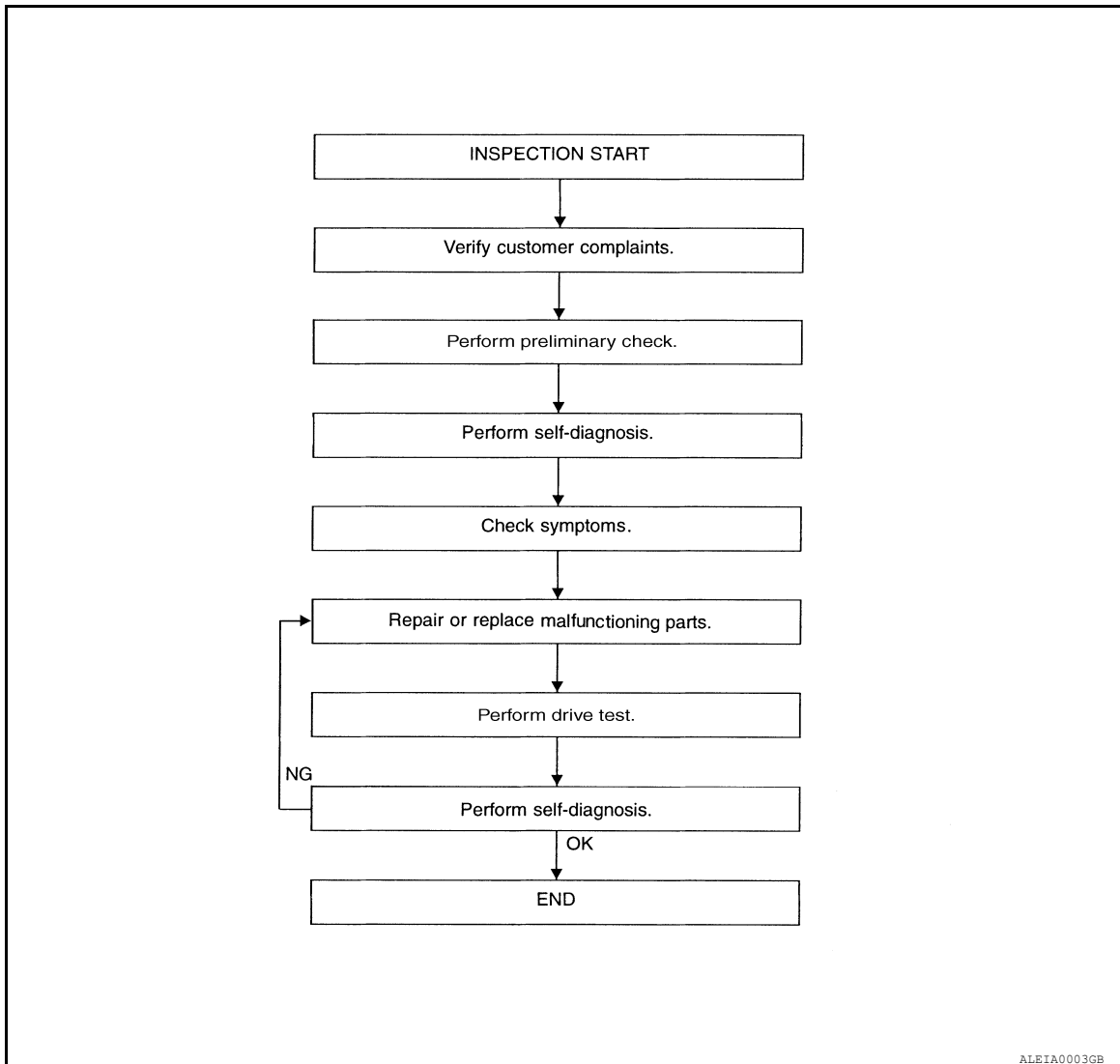

[WT-5. "Preliminary Check"](#)

[WT-31. "Self-Diagnosis \(With CONSULT\)"](#)  
[WT-32. "Self-Diagnosis \(Without CONSULT\)"](#)

[WT-38. "Symptom Table"](#)

DETAILED FLOW

#### 1. CUSTOMER INFORMATION

Interview the customer to obtain detailed information about the symptom.

>> GO TO 2

#### 2. PRELIMINARY CHECK

Perform preliminary check. Refer to [WT-5. "Preliminary Check"](#).

>> GO TO 3

# DIAGNOSIS AND REPAIR WORKFLOW

< BASIC INSPECTION >

---

## 3.SELF-DIAGNOSIS

---

Perform SELF-DIAGNOSIS. Refer to [WT-31. "Self-Diagnosis \(With CONSULT\)"](#) or [WT-32. "Self-Diagnosis \(Without CONSULT\)"](#).

>> GO TO 4

## 4.SYMPTOM

---

Check for symptoms. Refer to [WT-38. "Symptom Table"](#).

>> GO TO 5

## 5.MALFUNCTIONING PARTS

---

Repair or replace the applicable parts.

>> GO TO 6

## 6.DRIVE TEST

---

1. Perform a drive test.
2. Check the low tire pressure warning lamp.

>> GO TO 7

## 7.SELF-DIAGNOSIS

---

Perform SELF-DIAGNOSIS. Refer to [WT-31. "Self-Diagnosis \(With CONSULT\)"](#) or [WT-32. "Self-Diagnosis \(Without CONSULT\)"](#).

Are any DTC's displayed?

- YES >> GO TO 5  
NO >> Inspection End

# INSPECTION AND ADJUSTMENT

< BASIC INSPECTION >

## INSPECTION AND ADJUSTMENT

### Preliminary Check

INFOID:000000007357033

#### NOTE:

The Signal Tech II Tool (J-50190) can be used to perform the following functions. Refer to the Signal Tech II User Guide for additional information.

- Activate and display TPMS transmitter IDs
- Display tire pressure reported by the TPMS transmitter
- Read TPMS DTCs
- Register TPMS transmitter IDs

### 1. TIRE PRESSURE

Check all tire pressures. Refer to [WT-55, "Tire"](#).

Do tire pressures match specification?

- YES >> GO TO 2.
- NO >> Adjust tire pressures to specified value.

### 2. LOW TIRE PRESSURE WARNING LAMP

Check low tire pressure warning lamp activation.

Does the low tire pressure warning lamp activate for one second when ignition switch is turned ON?

- YES >> GO TO 3.
- NO >> GO TO [WT-39, "Low Tire Pressure Warning Lamp Does Not Come On When Ignition Switch Is Turned On"](#).

### 3. BCM CONNECTOR

1. Disconnect BCM harness connectors.
2. Check terminals for damage or loose connections.
3. Reconnect harness connectors.

Are BCM connectors damaged or loose?

- YES >> Repair or replace damaged parts.
- NO >> GO TO 4.

### 4. TRANSMITTER ACTIVATION TOOL

Check battery in transmitter activation tool.

Is transmitter activation tool battery fully charged?

- YES >> Perform self-diagnosis. Refer to [WT-31, "Self-Diagnosis \(With CONSULT\)"](#).
- NO >> Replace battery in transmitter activation tool.

### Transmitter Wake Up Operation

INFOID:000000007357034

#### NOTE:

This procedure must be done after replacement of a TPMS transmitter or BCM. New replacement transmitters are provided "asleep" and must first be "woken up" using Transmitter Activation Tool J-45295 or Signal Tech II Tool J-50190 before ID registration can be performed. Use the following procedure when using the Transmitter Activation Tool J-45295.

#### NOTE:

The Signal Tech II Tool (J-50190) can be used to perform the following functions. Refer to the Signal Tech II User Guide for additional information.

- Activate and display TPMS transmitter IDs
- Display tire pressure reported by the TPMS transmitter
- Read TPMS DTCs
- Register TPMS transmitter IDs

# INSPECTION AND ADJUSTMENT

## < BASIC INSPECTION >

1. Turn ignition switch ON. Push the transmitter activation tool against the tire near the front left transmitter. Press the button for 5 seconds. The hazard warning lamps flash per the following diagram.

**Tool number : (J-45295)**

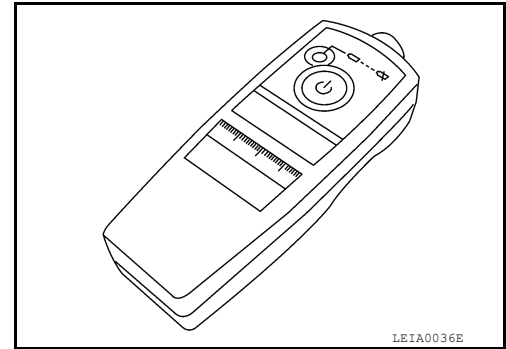

2. Repeat this procedure for each tire in the following order: FL, FR, RR, RL.
3. When the BCM finishes assigning each tire ID, the BCM flashes the hazard warning lamps and sends flashing indicator status by CAN according to the following time chart.

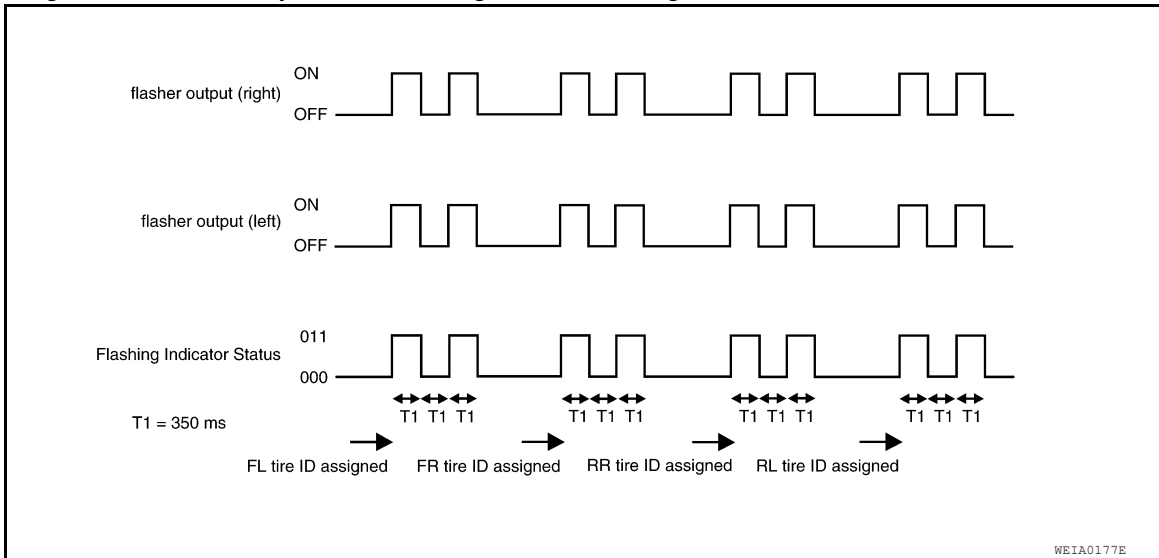

4. After completing wake up of all transmitters, make sure low tire pressure warning lamp goes out.

## ID Registration Procedure

INFOID:000000007357035

### NOTE:

The Signal Tech II Tool (J-50190) can be used to perform the following functions. Refer to the Signal Tech II User Guide for additional information.

- Activate and display TPMS transmitter IDs
- Display tire pressure reported by the TPMS transmitter
- Read TPMS DTCs
- Register TPMS transmitter IDs

## ID REGISTRATION WITH TRANSMITTER ACTIVATION TOOL

### NOTE:

This procedure must be done after replacement of a TPMS transmitter or BCM. New replacement transmitters are provided "asleep" and must first be "woken up" using Transmitter Activation Tool J-45295 or Signal Tech II Tool J-50190 before ID registration can be performed. Use the following procedure when using the Transmitter Activation Tool J-45295.

1. Connect CONSULT.
2. Select ID REGIST under BCM.

# INSPECTION AND ADJUSTMENT

## < BASIC INSPECTION >

- Push the transmitter activation tool against the tire near the front left transmitter. Press the button for 5 seconds.

**Tool number : (J-45295)**

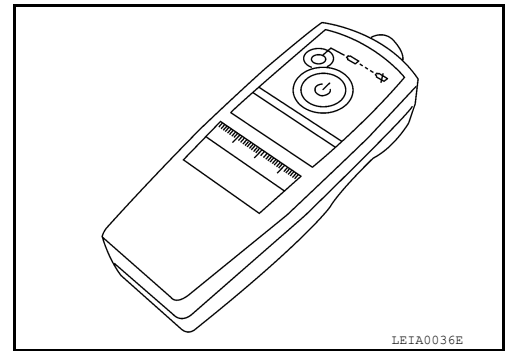

- Register the IDs in order from FR LH, FR RH, RR RH and RR LH. When ID registration of each wheel has been completed, the hazard warning lamps flash.

Step	Activation tire position	Hazard warning lamp	CONSULT
1	Front LH	2 times flashing	YET ↓ DONE
2	Front RH		
3	Rear RH		
4	Rear LH		

- After completing all ID registrations, press END to complete the procedure.

**NOTE:**

Be sure to register all of the IDs in order from FR LH, FR RH, RR RH, to RR LH, or the self-diagnostic results display will not function properly.

### ID REGISTRATION WITHOUT TRANSMITTER ACTIVATION TOOL

**NOTE:**

This procedure must be done after replacement of a TPMS transmitter or BCM. New replacement transmitters are provided "asleep" and must first be "woken up" using Transmitter Activation Tool J-45295 or Signal Tech II Tool J-50190 before ID registration can be performed.

- Connect CONSULT.
- Select ID REGIST under BCM.
- Adjust the tire pressures to the values shown in the table and drive the vehicle at 40 km/h (25 MPH) or more for a few minutes.

Tire position	Tire pressure kPa (kg/cm <sup>2</sup> , psi)
Front LH	250 (2.5, 36)
Front RH	230 (2.3, 33)
Rear RH	210 (2.1, 30)
Rear LH	190 (1.9, 27)

- After completing all ID registrations, press END to complete the procedure.

Activation tire position	CONSULT
Front LH	YET ↓ DONE
Front RH	
Rear RH	
Rear LH	

- Inflate all tires to proper pressure. Refer to [WT-55, "Tire"](#).

# TPMS

< SYSTEM DESCRIPTION >

## SYSTEM DESCRIPTION

### TPMS

#### System Diagram

INFOID:000000007357036

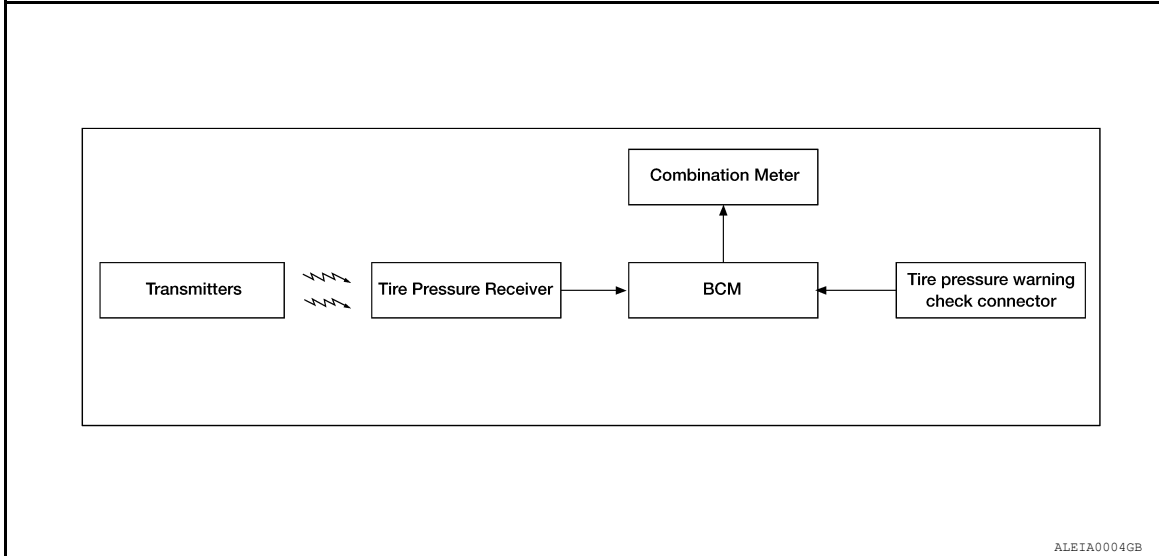

#### System Description

INFOID:000000007357037

#### DESCRIPTION

During driving, the tire pressure monitoring system receives the signal transmitted from the transmitter installed in each wheel, and turns on the low tire pressure warning lamp when the tire pressure becomes low. The control unit (BCM) for this system has pressure judgement and self-diagnosis functions.

#### FUNCTION

When the tire pressure monitoring system detects low inflation pressure or an internal malfunction, the low tire pressure warning lamp in the combination meter comes on. The malfunction is indicated by the low tire pressure warning lamp flashing.

#### BODY CONTROL MODULE (BCM)

The BCM (1) is shown with the lower instrument panel LH removed. The BCM reads the air pressure signal received by the remote keyless entry receiver, and controls the low tire pressure warning lamp as shown below. It also has a self-diagnosis function to detect a system malfunction.

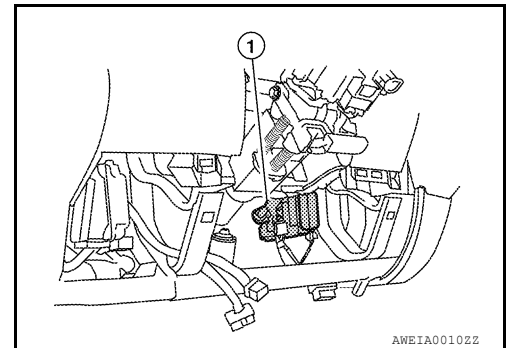

Condition	Low tire pressure warning lamp
System normal	On for 1 second after ignition ON
Tire less than 193 kPa (2.0 kg/cm <sup>2</sup> , 28 psi) [Flat tire]	ON
Low tire pressure warning system malfunction	After key ON, flashes once per second for 1 minute, then stays ON

#### TRANSMITTER



# TPMS

## < SYSTEM DESCRIPTION >

A sensor-transmitter integrated with a valve is installed in each wheel, and transmits a detected air pressure signal in the form of a radio wave. The radio signal is received by the remote keyless entry receiver.

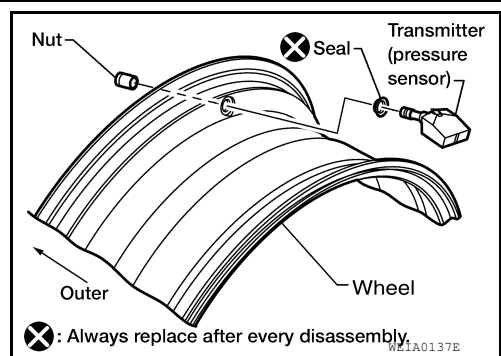

## REMOTE KEYLESS ENTRY RECEIVER

The remote keyless entry receiver is shown with the instrument panel RH removed. The remote keyless entry receiver receives the air pressure signal transmitted by the transmitter in each wheel.

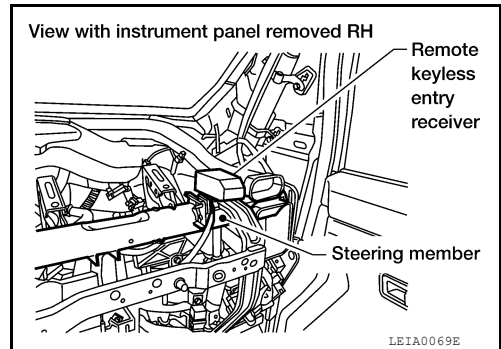

## COMBINATION METER

The combination meter receives tire pressure status from the BCM using CAN communication. When a low tire pressure condition is sensed by the BCM, the combination meter low tire pressure warning lamp is activated. A CHECK TIRE PRESSURE warning message will also be displayed in the odometer. Refer to the Owner's Manual for additional information.

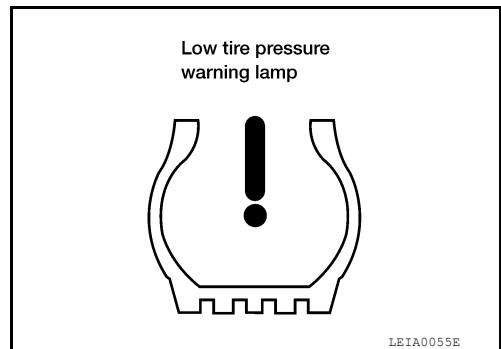

## TIRE PRESSURE WARNING CHECK CONNECTOR

The tire pressure warning check connector can be grounded in order to initiate self-diagnosis without a CONSULT. Refer to [WT-32. "Self-Diagnosis \(Without CONSULT\)"](#). The tire pressure warning check connector (1) is located behind the lower portion of the instrument panel LH.

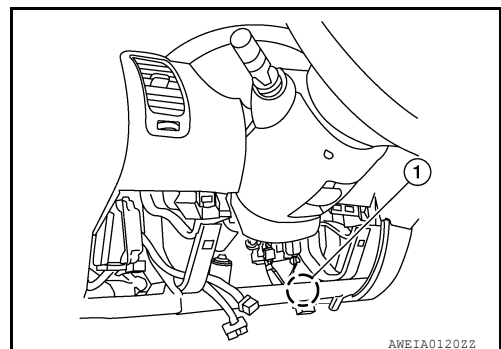

## DISPLAY UNIT (if equipped)

A  
B  
C  
D  
WT  
F  
G  
H  
I  
J  
K  
L  
M  
N  
O  
P

# TPMS

## < SYSTEM DESCRIPTION >

Displays the air pressure of each tire.

**NOTE:**

After the ignition switch is turned on, the pressure values will not be displayed until the data of each wheel is received.



## System Component

INFOID:000000007357038

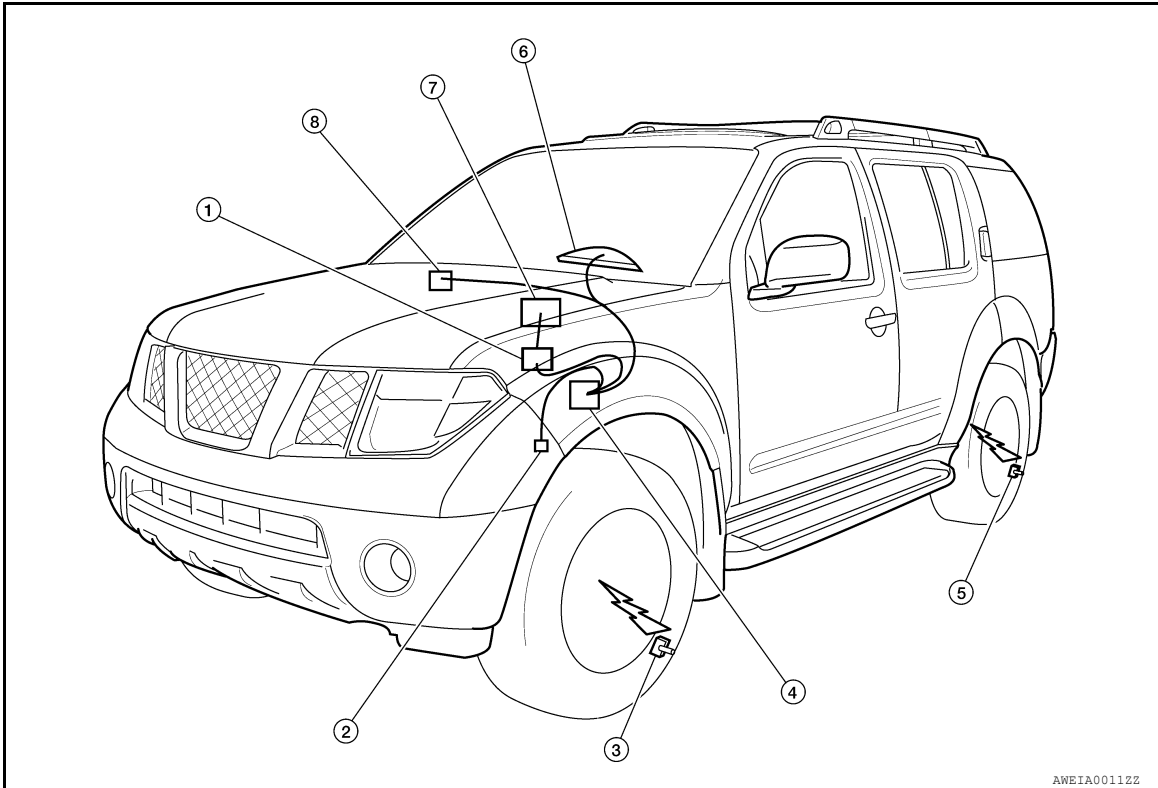

- |  |   |                          |
|--|---|--------------------------|
| 1. AV control unit M37, M48 (with BOSE audio system - with NAVI)<br>AV control unit M45, M70 (with BOSE audio system - without NAVI)<br>AV control unit M133, M135 (with mid audio system) | 2. Tire pressure warning check connector M123 | 3. Transmitter           |
| 4. BCM M18, M20  | 5. Transmitter                                | 6. Combination meter M24 |
| 7. Display unit M92 (with BOSE audio system - with NAVI)<br>Display unit M93 (with mid audio system or with BOSE audio system - without NAVI)  | 8. Remote keyless entry receiver M120         |                          |

# DIAGNOSIS SYSTEM (BCM)

< SYSTEM DESCRIPTION >

## DIAGNOSIS SYSTEM (BCM)

### CONSULT Function (BCM - COMMON ITEM)

INFOID:000000007829972

#### APPLICATION ITEM

CONSULT performs the following functions via CAN communication with BCM.

Direct Diagnostic Mode	Description
Ecu Identification	The BCM part number is displayed.
Self Diagnostic Result	The BCM self diagnostic results are displayed.
Data Monitor	The BCM input/output data is displayed in real time.
Active Test	The BCM activates outputs to test components.
Work support	The settings for BCM functions can be changed.
Configuration	<ul style="list-style-type: none"> <li>The vehicle specification can be read and saved.</li> <li>The vehicle specification can be written when replacing BCM.</li> </ul>
CAN Diag Support Mntr	The result of transmit/receive diagnosis of CAN communication is displayed.

#### SYSTEM APPLICATION

BCM can perform the following functions.

System	Sub System	Direct Diagnostic Mode						
		Ecu Identification	Self Diagnostic Result	Data Monitor	Active Test	Work support	Configuration	CAN Diag Support Mntr
Door lock	DOOR LOCK			x	x	x		
Rear window defogger	REAR DEFOGGER			x	x			
Warning chime	BUZZER			x	x			
Interior room lamp timer	INT LAMP			x	x	x		
Remote keyless entry system	MULTI REMOTE ENT			x	x	x		
Exterior lamp	HEAD LAMP			x	x	x		
Wiper and washer	WIPER			x	x	x		
Turn signal and hazard warning lamps	FLASHER			x	x			
Air conditioner	AIR CONDITIONER			x				
Intelligent Key system	INTELLIGENT KEY			x				
Combination switch	COMB SW			x				
BCM	BCM	x	x			x	x	x
Immobilizer	IMMU		x	x	x			
Interior room lamp battery saver	BATTERY SAVER			x	x	x		
Back door open	TRUNK			x	x			
Vehicle security system	THEFT ALM			x	x	x		
RAP system	RETAINED PWR			x	x	x		
Signal buffer system	SIGNAL BUFFER			x	x			
TPMS	AIR PRESSURE MONITOR		x	x	x	x		
Panic alarm system	PANIC ALARM				x			

# DIAGNOSIS SYSTEM (BCM)

< SYSTEM DESCRIPTION >

## CONSULT Function (BCM - AIR PRESSURE MONITOR)

INFOID:000000007829973

### NOTE:

The Signal Tech II Tool (J-50190) can be used to perform the following functions. Refer to the Signal Tech II User Guide for additional information.

- Activate and display TPMS transmitter IDs
- Display tire pressure reported by the TPMS transmitter
- Read TPMS DTCs
- Register TPMS transmitter IDs

### SELF DIAGNOSTIC RESULT

#### NOTE:

Before performing Self Diagnostic Result, be sure to register the ID, or else the actual malfunction may be different from that displayed on CONSULT.

Refer to [BCS-44, "DTC Index"](#).

### DATA MONITOR

Monitor Item	Condition	Specification
VEHICLE SPEED	Drive vehicle	Vehicle speed (km/h or mph)
AIR PRESS FL	• Drive vehicle for a few minutes. or • Ignition switch ON and activation tool is transmitting activation signals.	Tire pressure (kPa, kg/cm <sup>2</sup> or psi).
AIR PRESS FR		
AIR PRESS RR		
AIR PRESS RL		
ID REGST FL1	Ignition switch ON.	Registration ID: Green No registration: Red
ID REGST FR1		
ID REGST RR1		
ID REGST RL1		
WARNING LAMP	Ignition switch ON.	Low tire pressure warning lamp on: ON. Low tire pressure warning lamp off: OFF.
BUZZER	Ignition switch ON.	Buzzer in combination meter on: ON. Buzzer in combination meter off: OFF.

### ACTIVE TEST

Test Item	Description
WARNING LAMP	This test is able to check tire pressure warning lamp operation [Off/On].
ID REGIST WARNING	This test is able to check ID regist warning chime operation [Off/On].
FLAT TIRE WARNING	This test is able to check flat tire warning chime operation [Off/On].
HORN	This test is able to check horn operation [On].
FLASHER	This test is able to check turn signal lamp operation [Off/LH/RH].

### WORK SUPPORT

Support Item	Description
ID REGIST	Refer to <a href="#">WT-6, "ID Registration Procedure"</a> .
ID READ	The registered ID number is displayed.

### Self-Diagnosis (Without CONSULT)

INFOID:000000007829977

#### NOTE:

The Signal Tech II Tool (J-50190) can be used to perform the following functions. Refer to the Signal Tech II User Guide for additional information.

- Activate and display TPMS transmitter IDs
- Display tire pressure reported by the TPMS transmitter
- Read TPMS DTCs

# DIAGNOSIS SYSTEM (BCM)

## < SYSTEM DESCRIPTION >

- Register TPMS transmitter IDs

### SELF-DIAGNOSTIC PROCEDURE (WITHOUT CONSULT)

1. Turn ignition switch ON.
2. Ground the tire pressure warning check connector to initiate self diagnosis.
3. Compare the flashing pattern with the flash code chart below.

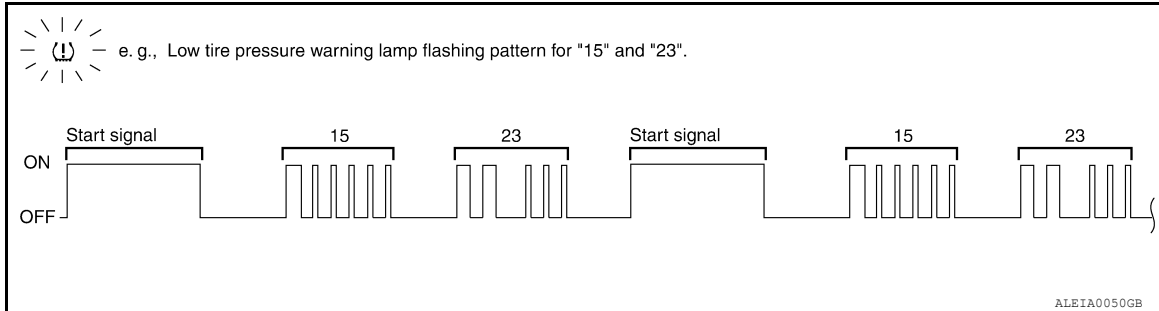

#### NOTE:

The system is normal when the low tire pressure warning lamp flashes 5 times and continues repeating. Self-diagnosis results are erased automatically by turning the ignition switch "OFF".

Flash Code	Malfunction part	Reference page
15 16 17 18	Tire pressure dropped below specified value. Refer to <a href="#">WT-8. "System Description"</a> .	—
21 22 23 24	Transmitter no data (FL) Transmitter no data (FR) Transmitter no data (RR) Transmitter no data (RL)	<a href="#">WT-14</a>
31 32 33 34	Transmitter checksum error (FL) Transmitter checksum error (FR) Transmitter checksum error (RR) Transmitter checksum error (RL)	<a href="#">WT-16</a>
35 36 37 38	Transmitter pressure data error (FL) Transmitter pressure data error (FR) Transmitter pressure data error (RR) Transmitter pressure data error (RL)	<a href="#">WT-18</a>
41 42 43 44	Transmitter function code error (FL) Transmitter function code error (FR) Transmitter function code error (RR) Transmitter function code error (RL)	<a href="#">WT-16</a>
45 46 47 48	Transmitter battery voltage low (FL) Transmitter battery voltage low (FR) Transmitter battery voltage low (RR) Transmitter battery voltage low (RL)	<a href="#">WT-16</a>
52	Vehicle speed signal	<a href="#">WT-20</a>
54	Vehicle ignition signal	<a href="#">WT-21</a>

# C1708 - C1711 DATA FROM TRANSMITTER NOT BEING RECEIVED

< DTC/CIRCUIT DIAGNOSIS >

## DTC/CIRCUIT DIAGNOSIS

### C1708 - C1711 DATA FROM TRANSMITTER NOT BEING RECEIVED

#### Description

INFOID:000000007357042

Tire pressure data for one or more transmitters is not being received by the BCM.

#### DTC Logic

INFOID:000000007357043

#### NOTE:

The Signal Tech II Tool (J-50190) can be used to perform the following functions. Refer to the Signal Tech II User Guide for additional information.

- Activate and display TPMS transmitter IDs
- Display tire pressure reported by the TPMS transmitter
- Read TPMS DTCs
- Register TPMS transmitter IDs

#### DTC DETECTION LOGIC

DTC	CONSULT	DTC detecting condition
C1708	[NO - DATA] - FL	Data from FL transmitter cannot be received.
C1709	[NO - DATA] - FR	Data from FR transmitter cannot be received.
C1710	[NO - DATA] - RR	Data from RR transmitter cannot be received.
C1711	[NO - DATA] - RL	Data from RL transmitter cannot be received.

#### DTC CONFIRMATION PROCEDURE

##### 1.ID REGISTRATION AND VEHICLE DRIVING

1. Carry out ID registration of all transmitters.
2. Drive at a speed of 40 km/h (25 MPH) or more for 3 minutes, and then drive the vehicle at any speed for 10 minutes.
3. Check all tire pressures with CONSULT within 5 minutes.

Does DATA MONITOR ITEM display tire pressure as normal without any warning lamp?

- YES >> Inspection End.  
NO >> Refer to [WT-14, "Diagnosis Procedure"](#).

#### Diagnosis Procedure

INFOID:000000007357044

#### NOTE:

The Signal Tech II Tool (J-50190) can be used to perform the following functions. Refer to the Signal Tech II User Guide for additional information.

- Activate and display TPMS transmitter IDs
- Display tire pressure reported by the TPMS transmitter
- Read TPMS DTCs
- Register TPMS transmitter IDs

MALFUNCTION CODE NO. 21, 22, 23 OR 24 (DTC C1708, C1709, C1710 OR C1711)

##### 1.CHECK BCM

Drive for several minutes. Check all tire pressures with CONSULT.

Are all tire pressures displayed as 0 kPa?

- YES >> GO TO 2  
NO >> GO TO 3

##### 2.CHECK TIRE PRESSURE RECEIVER CONNECTOR

Check tire pressure receiver connector for damage or loose connection.

Is tire pressure receiver connector damaged or loose?

- YES >> Repair or replace tire pressure receiver connector.

# C1708 - C1711 DATA FROM TRANSMITTER NOT BEING RECEIVED

< DTC/CIRCUIT DIAGNOSIS >

NO >> Replace BCM, then GO TO 3. Refer to [BCS-53, "Removal and Installation"](#).

## 3. PERFORM ID REGISTRATION

Carry out ID registration of all transmitters. Refer to [WT-6, "ID Registration Procedure"](#).

Is there a tire that cannot register ID?

YES >> Replace malfunctioning transmitter, then GO TO 5. Refer to [WT-52, "Transmitter \(Pressure Sensor\)"](#).

NO >> GO TO 4

## 4. DRIVE VEHICLE

1. Drive at a speed of 40 km/h (25 MPH) or more for several minutes without stopping.
2. Check all tire pressures with CONSULT within 15 minutes after vehicle speed becomes 17 km/h (11 MPH).

Does DATA MONITOR ITEM display tire pressure as normal without any warning lamp?

YES >> Inspection End.

NO >> GO TO 5

## 5. ID REGISTRATION AND VEHICLE DRIVING

1. Carry out ID registration of all transmitters.
2. Drive at a speed of 40 km/h (25 MPH) or more for 3 minutes, and then drive the vehicle at any speed for 10 minutes.
3. Check all tire pressures with CONSULT within 5 minutes.

Does DATA MONITOR ITEM display tire pressure as normal without any warning lamp?

YES >> Inspection End.

NO >> Proceed to the inspection applicable to DTC.

## Special Repair Requirement

INFOID:000000007357045

Perform preliminary check. Refer to [WT-5, "Preliminary Check"](#).

# C1712 - C1715, C1720 - C1723, C1724 - C1727 TRANSMITTER MALFUNCTION

< DTC/CIRCUIT DIAGNOSIS >

## C1712 - C1715, C1720 - C1723, C1724 - C1727 TRANSMITTER MALFUNCTION

### Description

INFOID:000000007357046

One or more transmitters are malfunctioning internally.

### DTC Logic

INFOID:000000007357047

#### NOTE:

The Signal Tech II Tool (J-50190) can be used to perform the following functions. Refer to the Signal Tech II User Guide for additional information.

- Activate and display TPMS transmitter IDs
- Display tire pressure reported by the TPMS transmitter
- Read TPMS DTCs
- Register TPMS transmitter IDs

### DTC DETECTION LOGIC

DTC	CONSULT	DTC detecting condition
C1712	[CHECKSUM - ERR] - FL	Checksum data from FL transmitter is malfunctioning.
C1713	[CHECKSUM - ERR] - FR	Checksum data from FR transmitter is malfunctioning.
C1714	[CHECKSUM - ERR] - RR	Checksum data from RR transmitter is malfunctioning.
C1715	[CHECKSUM - ERR] - RL	Checksum data from RL transmitter is malfunctioning.
C1720	[CODE - ERR] - FL	Function code data from FL transmitter is malfunctioning.
C1721	[CODE - ERR] - FR	Function code data from FR transmitter is malfunctioning.
C1722	[CODE - ERR] - RR	Function code data from RR transmitter is malfunctioning.
C1723	[CODE - ERR] - RL	Function code data from RL transmitter is malfunctioning.
C1724	[BATT - VOLT - LOW] - FL	Battery voltage of FL transmitter drops.
C1725	[BATT - VOLT - LOW] - FR	Battery voltage of FR transmitter drops.
C1726	[BATT - VOLT - LOW] - RR	Battery voltage of RR transmitter drops.
C1727	[BATT - VOLT - LOW] - RL	Battery voltage of RL transmitter drops.

### DTC CONFIRMATION PROCEDURE

#### 1. DRIVE VEHICLE

1. Drive at a speed of 40 km/h (25 MPH) or more for 3 minutes, and then drive the vehicle at any speed for 10 minutes.
2. Check all tire pressures with CONSULT within 5 minutes.

Does DATA MONITOR ITEM display tire pressure as normal without any warning lamp?

YES >> Inspection End.

NO >> Refer to [WT-16, "Diagnosis Procedure"](#).

### Diagnosis Procedure

INFOID:000000007357048

#### NOTE:

The Signal Tech II Tool (J-50190) can be used to perform the following functions. Refer to the Signal Tech II User Guide for additional information.

- Activate and display TPMS transmitter IDs
- Display tire pressure reported by the TPMS transmitter
- Read TPMS DTCs
- Register TPMS transmitter IDs

MALFUNCTION CODE NO. 31, 32, 33, 34, 41, 42, 43, 44, 45, 46, 47 OR 48 (DTC C1712, C1713, C1714, C1715, C1720, C1721, C1722, C1723, C1724, C1725, C1726 OR C1727)

#### 1. PERFORM ID REGISTRATION



# C1712 - C1715, C1720 - C1723, C1724 - C1727 TRANSMITTER MALFUNCTION

< DTC/CIRCUIT DIAGNOSIS >

1. Carry out ID registration of all transmitters. Refer to [WT-6, "ID Registration Procedure"](#).
2. Drive at a speed of 40 km/h (25 MPH) or more for 3 minutes, and then drive the vehicle at any speed for 10 minutes.

>> GO TO 2

## 2. REPLACE TRANSMITTER

1. Check low tire pressure warning lamp again for flashing, replace malfunctioning transmitter. Refer to [WT-52, "Transmitter \(Pressure Sensor\)"](#).
2. Carry out ID registration of all transmitters.

Can ID registration of all transmitters be completed?

YES >> GO TO 3

NO >> GO TO [WT-14, "Diagnosis Procedure"](#).

## 3. DRIVE VEHICLE

1. Drive at a speed of 40 km/h (25 MPH) or more for 3 minutes, and then drive the vehicle at any speed for 10 minutes.
2. Check all tire pressures with CONSULT within 5 minutes.

Does DATA MONITOR ITEM display tire pressure as normal without any warning lamp?

YES >> Inspection End.

NO >> Replace malfunctioning transmitter, and perform Step 3 again.

## Special Repair Requirement

INFOID:000000007829978

Perform preliminary check. Refer to [WT-5, "Preliminary Check"](#).

WT

# C1716 - C1719 TRANSMITTER PRESSURE MALFUNCTION

< DTC/CIRCUIT DIAGNOSIS >

## C1716 - C1719 TRANSMITTER PRESSURE MALFUNCTION

### Description

INFOID:000000007357050

Air pressure data from one or more transmitters is out of range.

### DTC Logic

INFOID:000000007357051

#### NOTE:

The Signal Tech II Tool (J-50190) can be used to perform the following functions. Refer to the Signal Tech II User Guide for additional information.

- Activate and display TPMS transmitter IDs
- Display tire pressure reported by the TPMS transmitter
- Read TPMS DTCs
- Register TPMS transmitter IDs

### DTC DETECTION LOGIC

DTC	CONSULT	DTC detecting condition
C1716	[PRESSDATA - ERR] FL	Air pressure data from FL transmitter is malfunctioning.
C1717	[PRESSDATA - ERR] FR	Air pressure data from FR transmitter is malfunctioning.
C1718	[PRESSDATA - ERR] RR	Air pressure data from RR transmitter is malfunctioning.
C1719	[PRESSDATA - ERR] RL	Air pressure data from RL transmitter is malfunctioning.

### DTC CONFIRMATION PROCEDURE

#### 1. ID REGISTRATION AND VEHICLE DRIVING

1. Carry out ID registration of all transmitters.
2. Drive at a speed of 40 km/h (25 MPH) or more for 3 minutes, and then drive the vehicle at any speed for 10 minutes.
3. Check all tire pressures with CONSULT within 5 minutes.

Does DATA MONITOR ITEM display tire pressure as normal without any warning lamp?

- YES >> Inspection End.  
NO >> Refer to [WT-18, "Diagnosis Procedure"](#).

### Diagnosis Procedure

INFOID:000000007357052

#### NOTE:

The Signal Tech II Tool (J-50190) can be used to perform the following functions. Refer to the Signal Tech II User Guide for additional information.

- Activate and display TPMS transmitter IDs
- Display tire pressure reported by the TPMS transmitter
- Read TPMS DTCs
- Register TPMS transmitter IDs

MALFUNCTION CODE NO. 35, 36, 37 OR 38 (DTC C1716, C1717, C1718 OR C1719)

#### 1. CHECK ALL TIRE PRESSURES

Check all tire pressures. Refer to [WT-55, "Tire"](#).

Are there any tires with pressure of 64 psi or more?

- YES >> Adjust tire pressure to specified value.  
NO >> GO TO 2

#### 2. ID REGISTRATION AND VEHICLE DRIVING

1. Carry out ID registration of all transmitters. Refer to [WT-6, "ID Registration Procedure"](#).
2. Drive at a speed of 40 km/h (25 MPH) or more for several minutes without stopping.
3. Check all tire pressures with CONSULT within 15 minutes after vehicle speed becomes 17 km/h (11 MPH).

Does DATA MONITOR ITEM display 64 psi or more?

# C1716 - C1719 TRANSMITTER PRESSURE MALFUNCTION

## < DTC/CIRCUIT DIAGNOSIS >

---

- YES >> Replace transmitter. Refer to [WT-52. "Transmitter \(Pressure Sensor\)"](#). GO TO 3.  
NO >> GO TO 3

## 3.ID REGISTRATION AND VEHICLE DRIVING

---

1. Carry out ID registration of all transmitters.
2. Drive at a speed of 40 km/h (25 MPH) or more for 3 minutes, and then drive the vehicle at any speed for 10 minutes.
3. Check all tire pressures with CONSULT within 5 minutes.

Does DATA MONITOR ITEM display tire pressure as normal without any warning lamp?

- YES >> Inspection End.  
NO >> Proceed to the inspection applicable to DTC.

## Special Repair Requirement

INFOID:000000007829981

Perform preliminary check. Refer to [WT-5. "Preliminary Check"](#).

A  
B  
C  
D  
E  
F  
G  
H  
I  
J  
K  
L  
M  
N  
O  
P

WT

# C1729 VEHICLE SPEED SIGNAL

< DTC/CIRCUIT DIAGNOSIS >

## C1729 VEHICLE SPEED SIGNAL

### Description

INFOID:000000007357054

The vehicle speed signal is not being detected by the BCM.

### DTC Logic

INFOID:000000007357055

#### NOTE:

The Signal Tech II Tool (J-50190) can be used to perform the following functions. Refer to the Signal Tech II User Guide for additional information.

- Activate and display TPMS transmitter IDs
- Display tire pressure reported by the TPMS transmitter
- Read TPMS DTCs
- Register TPMS transmitter IDs

### DTC DETECTION LOGIC

DTC	CONSULT	DTC detecting condition
C1729	VHCL SPEED SIG ERR	Vehicle speed signal is in error.

### DTC CONFIRMATION PROCEDURE

#### 1. CHECK SELF-DIAGNOSTIC RESULTS

1. On SELECT DIAG MODE, select the SELF-DIAG RESULT screen.
2. Check display contents on SELF DIAG RESULT screen.

Is the CAN COMM CIRCUIT displayed in the self-diagnosis display?

- YES >> Refer to [WT-20, "Diagnosis Procedure"](#).  
NO >> Inspection end.

### Diagnosis Procedure

INFOID:000000007357056

#### NOTE:

The Signal Tech II Tool (J-50190) can be used to perform the following functions. Refer to the Signal Tech II User Guide for additional information.

- Activate and display TPMS transmitter IDs
- Display tire pressure reported by the TPMS transmitter
- Read TPMS DTCs
- Register TPMS transmitter IDs

### MALFUNCTION CODE NO. 52 (DTC C1729)

#### 1. CHECK SELF-DIAGNOSTIC RESULTS

1. On SELECT DIAG MODE, select the SELF-DIAG RESULT screen.
2. Check display contents on SELF DIAG RESULT screen.

Is the CAN COMM CIRCUIT displayed in the self-diagnosis display?

- YES >> Perform trouble diagnosis for CAN communication system. Refer to [LAN-14, "Trouble Diagnosis Flow Chart"](#).  
NO >> Check combination meter. Refer to [MWI-27, "CONSULT Function \(METER/M&A\)"](#).

### Special Repair Requirement

INFOID:000000007829980

Perform preliminary check. Refer to [WT-5, "Preliminary Check"](#).

# C1735 IGNITION SIGNAL

< DTC/CIRCUIT DIAGNOSIS >

## C1735 IGNITION SIGNAL

### Description

INFOID:000000007357058

The BCM monitors the IGN ON signal on the CAN line and compares it to its direct IGN ON signal. When these two signals do not match, the BCM sets C1735.

### DTC Logic

INFOID:000000007357059

#### NOTE:

The Signal Tech II Tool (J-50190) can be used to perform the following functions. Refer to the Signal Tech II User Guide for additional information.

- Activate and display TPMS transmitter IDs
- Display tire pressure reported by the TPMS transmitter
- Read TPMS DTCs
- Register TPMS transmitter IDs

### DTC DETECTION LOGIC

DTC	CONSULT	DTC detecting condition
C1735	IGNITION SIGNAL LINE - BCM/TPMS	BCM has detected a mismatch between IGN ON signals.

### DTC CONFIRMATION PROCEDURE

#### 1. CHECK SELF-DIAGNOSTIC RESULTS

1. On SELECT DIAG MODE, select the SELF-DIAG RESULT screen.
2. Check display contents on SELF DIAG RESULT screen.

Is C1735 displayed in the self-diagnosis display?

- YES >> Refer to [WT-21, "Diagnosis Procedure"](#).  
NO >> Inspection End.

### Diagnosis Procedure

INFOID:000000007357060

#### NOTE:

The Signal Tech II Tool (J-50190) can be used to perform the following functions. Refer to the Signal Tech II User Guide for additional information.

- Activate and display TPMS transmitter IDs
- Display tire pressure reported by the TPMS transmitter
- Read TPMS DTCs
- Register TPMS transmitter IDs

### MALFUNCTION CODE NO. 54 (DTC C1735)

#### 1. CAN IGNITION SIGNAL

Check BCM IGN RLY signal with CONSULT. Refer to [BCS-35, "Reference Value"](#).

Are the inspection results normal with the ignition switch ON?

- YES >> GO TO 2.  
NO >> Check CAN system. Refer to [LAN-14, "Trouble Diagnosis Flow Chart"](#).

#### 2. BCM POWER SUPPLY

Check BCM power supply (ignition ON). Refer to [BCS-30, "Diagnosis Procedure"](#).

Is the power supply with the ignition switch ON normal?

- YES >> GO TO 3.  
NO >> Repair power supply as necessary.

#### 3. DRIVE VEHICLE

Clear DTC and then test drive the vehicle and check the low tire pressure warning lamp.

Does the vehicle operate without any low tire pressure warning lamp?

- YES >> Inspection End.  
NO >> Replace BCM. Refer to [BCS-53, "Removal and Installation"](#).

## C1735 IGNITION SIGNAL

< DTC/CIRCUIT DIAGNOSIS >

---

### Special Repair Requirement

INFOID:000000007829979

Perform preliminary check. Refer to [WT-5. "Preliminary Check"](#).

## BCM (BODY CONTROL MODULE)

< ECU DIAGNOSIS INFORMATION >

### ECU DIAGNOSIS INFORMATION

#### BCM (BODY CONTROL MODULE)

##### Reference Value

INFOID:000000007829974

**NOTE:**

The Signal Tech II Tool (J-50190) can be used to perform the following functions. Refer to the Signal Tech II User Guide for additional information.

- Activate and display TPMS transmitter IDs
- Display tire pressure reported by the TPMS transmitter
- Read TPMS DTCs
- Register TPMS transmitter IDs

##### VALUES ON THE DIAGNOSIS TOOL

Monitor Item	Condition	Value/Status
ACC ON SW	Ignition switch OFF or ON	Off
	Ignition switch ACC	On
AIR COND SW	A/C switch OFF	Off
	A/C switch ON	On
AIR PRESS FL	Front left tire air pressure value	kPa, kg/cm <sup>2</sup> , psi
AIR PRESS FR	Front right tire air pressure value	kPa, kg/cm <sup>2</sup> , psi
AIR PRESS RL	Rear left tire air pressure value	kPa, kg/cm <sup>2</sup> , psi
AIR PRESS RR	Rear right tire air pressure value	kPa, kg/cm <sup>2</sup> , psi
AUTO LIGHT SW	Lighting switch OFF	Off
	Lighting switch AUTO	On
BACK DOOR SW	Back door closed	Off
	Back door opened	On
BRAKE SW	Brake pedal released	Off
	Brake pedal applied	On
BUCKLE SW	Seat belt buckle unfastened	Off
	Seat belt buckle fastened	On
BUZZER	Buzzer in combination meter OFF	Off
	Buzzer in combination meter ON	On
CDL LOCK SW	Door lock/unlock switch does not operate	Off
	Press door lock/unlock switch to the LOCK side	On
CDL UNLOCK SW	Door lock/unlock switch does not operate	Off
	Press door lock/unlock switch to the UNLOCK side	On
DOOR SW-AS	Front door RH closed	Off
	Front door RH opened	On
DOOR SW-DR	Front door LH closed	Off
	Front door LH opened	On
DOOR SW-RL	Rear door LH closed	Off
	Rear door LH opened	On
DOOR SW-RR	Rear door RH closed	Off
	Rear door RH opened	On
FAN ON SIG	Blower motor fan switch OFF	Off
	Blower motor fan switch ON	On

## BCM (BODY CONTROL MODULE)

### < ECU DIAGNOSIS INFORMATION >

Monitor Item	Condition	Value/Status
FR FOG SW	Front fog lamp switch OFF	Off
	Front fog lamp switch ON	On
FR WASHER SW	Front washer switch OFF	Off
	Front washer switch ON	On
FR WIPER LOW	Front wiper switch OFF	Off
	Front wiper switch LO	On
FR WIPER HI	Front wiper switch OFF	Off
	Front wiper switch HI	On
FR WIPER INT	Front wiper switch OFF	Off
	Front wiper switch INT	On
FR WIPER STOP	Any position other than front wiper stop position	Off
	Front wiper stop position	On
HAZARD SW	When hazard switch is not pressed	Off
	When hazard switch is pressed	On
HEAD LAMP SW 1	Headlamp switch OFF	Off
	Headlamp switch 1st	On
HEAD LAMP SW 2	Headlamp switch OFF	Off
	Headlamp switch 1st	On
HI BEAM SW	High beam switch OFF	Off
	High beam switch HI	On
ID REGST FL1	ID registration of front left tire incomplete	YET
	ID registration of front left tire complete	DONE
ID REGST FR1	ID registration of front right tire incomplete	YET
	ID registration of front right tire complete	DONE
ID REGST RL1	ID registration of rear left tire incomplete	YET
	ID registration of rear left tire complete	DONE
ID REGST RR1	ID registration of rear right tire incomplete	YET
	ID registration of rear right tire complete	DONE
IGN ON SW	Ignition switch OFF or ACC	Off
	Ignition switch ON	On
IGN SW CAN	Ignition switch OFF or ACC	Off
	Ignition switch ON	On
INT VOLUME	Wiper intermittent dial is in a dial position 1 - 7	1 - 7
I-KEY LOCK <sup>1</sup>	LOCK button of Intelligent Key is not pressed	Off
	LOCK button of Intelligent Key is pressed	On
I-KEY PANIC <sup>1</sup>	PANIC button of Intelligent Key is not pressed	Off
	PANIC button of Intelligent Key is pressed	On
I-KEY PW DWN <sup>1</sup>	UNLOCK button of Intelligent Key is not pressed	Off
	UNLOCK button of Intelligent Key is pressed for greater than 3 seconds and driver's window operating in DOWN direction	On
I-KEY UNLOCK <sup>1</sup>	UNLOCK button of Intelligent Key is not pressed	Off
	UNLOCK button of Intelligent Key is pressed	On
KEY CYL LK-SW	Door key cylinder LOCK position	Off
	Door key cylinder other than LOCK position	On



## BCM (BODY CONTROL MODULE)

### < ECU DIAGNOSIS INFORMATION >

Monitor Item	Condition	Value/Status	
KEY CYL UN-SW	Door key cylinder UNLOCK position	Off	A
	Door key cylinder other than UNLOCK position	On	
KEY ON SW	Mechanical key is removed from key cylinder	Off	B
	Mechanical key is inserted to key cylinder	On	
KEYLESS LOCK <sup>2</sup>	LOCK button of key fob is not pressed	Off	C
	LOCK button of key fob is pressed	On	
KEYLESS PANIC <sup>2</sup>	PANIC button of key fob is not pressed	Off	D
	PANIC button of key fob is pressed	On	
KEYLESS UNLOCK <sup>2</sup>	UNLOCK button of key fob is not pressed	Off	
	UNLOCK button of key fob is pressed	On	
LIGHT SW 1ST	Lighting switch OFF	Off	WT
	Lighting switch 1st	On	
OIL PRESS SW	<ul style="list-style-type: none"> <li>• Ignition switch OFF or ACC</li> <li>• Engine running</li> </ul>	Off	F
	Ignition switch ON	On	
OPTICAL SENSOR	Bright outside of the vehicle	Close to 5V	G
	Dark outside of the vehicle	Close to 0V	
PASSING SW	Other than lighting switch PASS	Off	H
	Lighting switch PASS	On	
PUSH SW <sup>1</sup>	Return to ignition switch to LOCK position	Off	I
	Press ignition switch	On	
REAR DEF SW	Rear window defogger switch OFF	Off	J
	Rear window defogger switch ON	On	
RR WASHER SW	Rear washer switch OFF	Off	K
	Rear washer switch ON	On	
RR WIPER INT	Rear wiper switch OFF	Off	L
	Rear wiper switch INT	On	
RR WIPER ON	Rear wiper switch OFF	Off	M
	Rear wiper switch ON	On	
RR WIPER STOP	Rear wiper stop position	Off	N
	Other than rear wiper stop position	On	
TURN SIGNAL L	Turn signal switch OFF	Off	O
	Turn signal switch LH	On	
TURN SIGNAL R	Turn signal switch OFF	Off	P
	Turn signal switch RH	On	
VEHICLE SPEED	While driving	Equivalent to speedometer reading	
WARNING LAMP	Low tire pressure warning lamp in combination meter OFF	Off	
	Low tire pressure warning lamp in combination meter ON	On	

1: With Intelligent Key

2: With remote keyless entry system

# BCM (BODY CONTROL MODULE)

< ECU DIAGNOSIS INFORMATION >

## Terminal Layout

INFOID:000000007829975

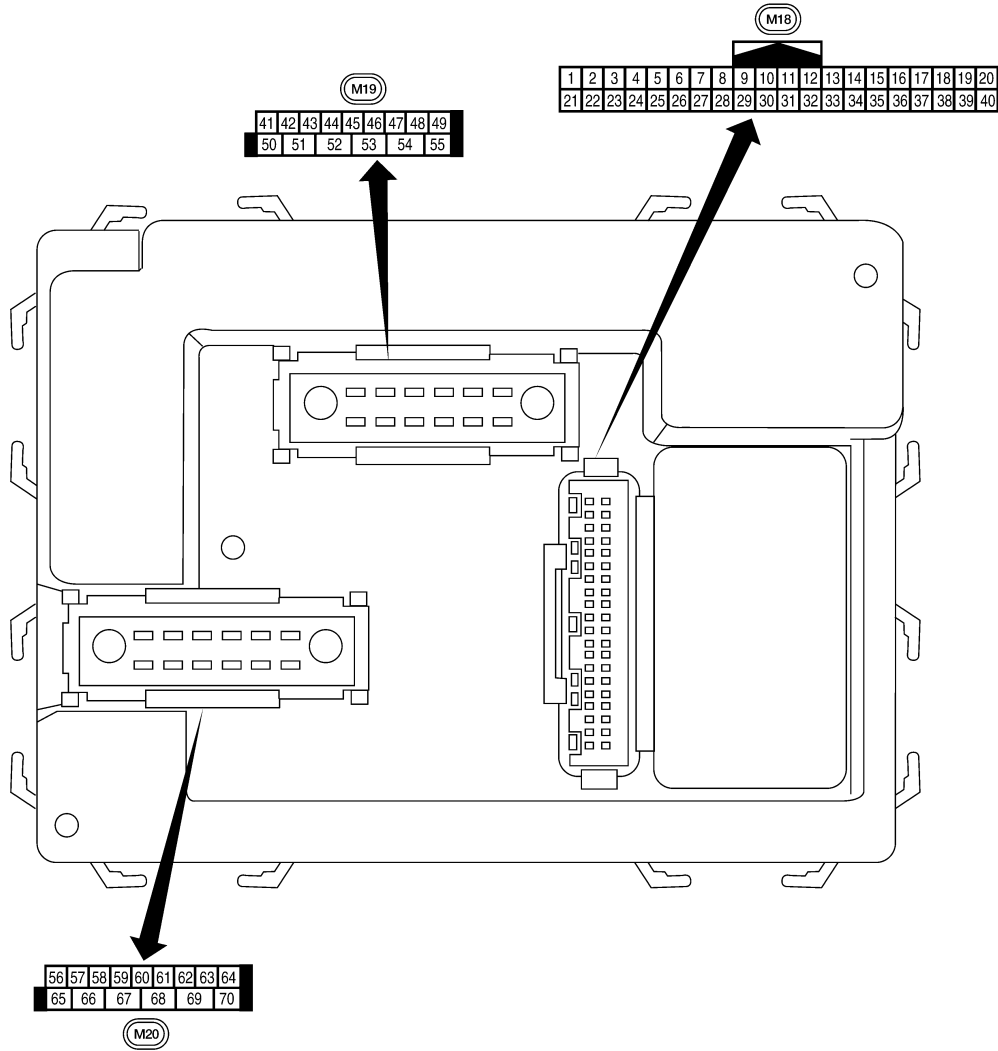



LIIA2443E

## Physical Values

INFOID:000000007829976

# BCM (BODY CONTROL MODULE)

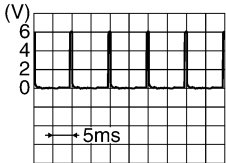
## < ECU DIAGNOSIS INFORMATION >

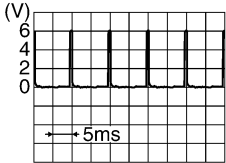
Terminal	Wire color	Signal name	Signal input/output	Measuring condition		Reference value or waveform (Approx.)
				Ignition switch	Operation or condition	
1	BR	Ignition keyhole illumination	Output	OFF	Door is locked (SW OFF)	Battery voltage
					Door is unlocked (SW ON)	0V
2	P	Combination switch input 5	Input	ON	Lighting, turn, wiper OFF Wiper dial position 4	 SKIA5291E
3	SB	Combination switch input 4	Input	ON	Lighting, turn, wiper OFF Wiper dial position 4	 SKIA5292E
4	V	Combination switch input 3	Input	ON	Lighting, turn, wiper OFF Wiper dial position 4	 SKIA5291E
5	L	Combination switch input 2	Input	ON	Lighting, turn, wiper OFF Wiper dial position 4	 SKIA5292E
6	R	Combination switch input 1				
9	Y	Rear window defogger switch	Input	ON	Rear window defogger switch ON	0V
					Rear window defogger switch OFF	5V
11	G/B	Ignition switch (ACC or ON)	Input	ACC or ON	Ignition switch ACC or ON	Battery voltage
12	LG	Front door switch RH	Input	OFF	ON (open)	0V
					OFF (closed)	Battery voltage
13	L	Rear door switch RH	Input	OFF	ON (open)	0V
					OFF (closed)	Battery voltage
15	W	Tire pressure warning check connector	Input	OFF	—	5V
18	BR	Remote keyless entry receiver and optical sensor (ground)	Output	OFF	—	0V

A

B

C

D

WT

F

G

H

I

J

K

L

M

N

O

P

# BCM (BODY CONTROL MODULE)

## < ECU DIAGNOSIS INFORMATION >

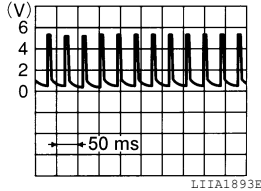
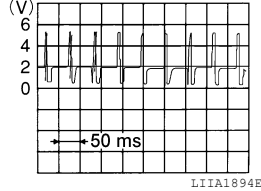
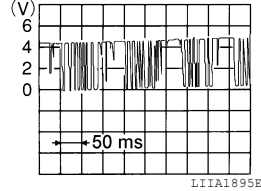
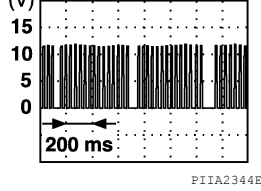
Terminal	Wire color	Signal name	Signal input/output	Measuring condition		Reference value or waveform (Approx.)
				Ignition switch	Operation or condition	
19	V	Remote keyless entry receiver (power supply)	Output	OFF	Ignition switch OFF	 <p style="text-align: right; font-size: small;">LIIA1893E</p>
20	G	Remote keyless entry receiver (signal)	Input	OFF	Stand-by (keyfob buttons released)	 <p style="text-align: right; font-size: small;">LIIA1894E</p>
					When remote keyless entry receiver receives signal from keyfob (keyfob buttons pressed)	 <p style="text-align: right; font-size: small;">LIIA1895E</p>
21	GR	NATS antenna amp.	Input	OFF → ON	Ignition switch (OFF → ON)	Just after turning ignition switch ON: Pointer of tester should move for approx. 1 second, then return to battery voltage.
22	V	BUS	—	—	Ignition switch ON or power window timer operates	 <p style="text-align: right; font-size: small;">PIIA2344E</p>
23	G	Security indicator lamp	Output	OFF	Goes OFF → illuminates (Every 2.4 seconds)	Battery voltage → 0V
25	BR	NATS antenna amp.	Input	OFF → ON	Ignition switch (OFF → ON)	Just after turning ignition switch ON: Pointer of tester should move for approx. 1 second, then return to battery voltage.
27	W	Compressor ON signal	Input	ON	A/C switch OFF	5V
					A/C switch ON	0V
28	R	Front blower monitor	Input	ON	Front blower motor OFF	Battery voltage
					Front blower motor ON	0V
29	G	Hazard switch	Input	OFF	ON	0V
					OFF	5V
30 <sup>1</sup>	G	Back door opener switch	Input	OFF	ON (open)	0V
					OFF (closed)	Battery voltage
30 <sup>2</sup>	SB	Back door opener switch	Input	OFF	ON (open)	0V
					OFF (closed)	Battery voltage

# BCM (BODY CONTROL MODULE)

## < ECU DIAGNOSIS INFORMATION >

Terminal	Wire color	Signal name	Signal input/output	Measuring condition		Reference value or waveform (Approx.)
				Ignition switch	Operation or condition	
32	O	Combination switch output 5	Output	ON	Lighting, turn, wiper OFF Wiper dial position 4	<p style="text-align: right; font-size: small;">SKIA5291E</p>
33	GR	Combination switch output 4	Output	ON	Lighting, turn, wiper OFF Wiper dial position 4	<p style="text-align: right; font-size: small;">SKIA5292E</p>
34	G	Combination switch output 3	Output	ON	Lighting, turn, wiper OFF Wiper dial position 4	<p style="text-align: right; font-size: small;">SKIA5291E</p>
35	BR	Combination switch output 2	Output	ON	Lighting, turn, wiper OFF Wiper dial position 4	<p style="text-align: right; font-size: small;">SKIA5292E</p>
36	LG	Combination switch output 1				
37 <sup>1</sup>	B	Key switch and key lock solenoid	Input	OFF	Key inserted	Battery voltage
					Key inserted	0V
37 <sup>2</sup>	B	Key switch and ignition knob switch	Input	OFF	Intelligent Key inserted	Battery voltage
					Intelligent Key inserted	0V
38	W/R	Ignition switch (ON)	Input	ON	—	Battery voltage
39	L	CAN-H	—	—	—	—
40	P	CAN-L	—	—	—	—
42	LG	Glass hatch ajar switch	Input	ON	Glass hatch open	0V
					Glass hatch closed	Battery voltage
43	P	Back door latch switch	Input	OFF	ON (open)	0V
					OFF (closed)	Battery voltage

A  
B  
C  
D  
WT  
F  
G  
H  
I  
J  
K  
L  
M  
N  
O  
P

# BCM (BODY CONTROL MODULE)

## < ECU DIAGNOSIS INFORMATION >

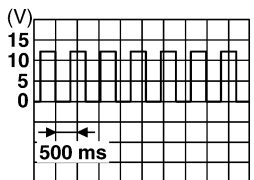
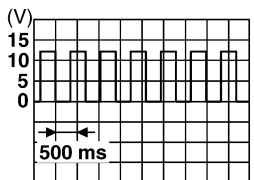
Terminal	Wire color	Signal name	Signal input/output	Measuring condition		Reference value or waveform (Approx.)
				Ignition switch	Operation or condition	
44	O	Rear wiper auto stop switch	Input	ON	Rise up position (rear wiper arm on stopper)	0V
					A Position (full clockwise stop position)	Battery voltage
					Forward sweep (counterclockwise direction)	Fluctuating
					B Position (full counterclockwise stop position)	0V
					Reverse sweep (clockwise direction)	Fluctuating
47	GR	Front door switch LH	Input	OFF	ON (open)	0V
					OFF (closed)	Battery voltage
48	P	Rear door switch LH	Input	OFF	ON (open)	0V
					OFF (closed)	Battery voltage
49	L	Cargo lamp	Output	OFF	Any door open (ON)	0V
					All doors closed (OFF)	Battery voltage
51	O	Trailer turn signal (right)	Output	ON	Turn right ON	 <p style="text-align: right; font-size: small;">SKIA3009J</p>
52	LG	Trailer turn signal (left)	Output	ON	Turn left ON	 <p style="text-align: right; font-size: small;">SKIA3009J</p>
53	L	Back door latch actuator	Output	OFF	OFF	0
					ON	Battery voltage
55	W	Rear wiper output circuit 1	Output	ON	OFF	0
					ON	Battery voltage
56	R/Y	Battery saver output	Output	OFF	15 minutes (early production) or 10 minutes (late production) after ignition switch is turned OFF	0V
				ON	—	Battery voltage
57	R/Y	Battery power supply	Input	OFF	—	Battery voltage
58	W	Optical sensor	Input	ON	When optical sensor is illuminated	3.1V or more
					When optical sensor is not illuminated	0.6V or less
59	GR	Front door lock assembly LH actuator (unlock)	Output	OFF	OFF (neutral)	0V
					ON (unlock)	Battery voltage

# BCM (BODY CONTROL MODULE)

## < ECU DIAGNOSIS INFORMATION >

Terminal	Wire color	Signal name	Signal input/output	Measuring condition		Reference value or waveform (Approx.)
				Ignition switch	Operation or condition	
60	LG	Turn signal (left)	Output	ON	Turn left ON	<p>SKIA3009J</p>
61	G	Turn signal (right)	Output	ON	Turn right ON	<p>SKIA3009J</p>
63	BR	Interior room/map lamp	Output	OFF	Any door switch	ON (open) 0V
					OFF (closed)	Battery voltage
65	V	All door lock actuators (lock)	Output	OFF	OFF (neutral)	0V
					ON (lock)	Battery voltage
66	L	Front door lock actuator RH, rear door lock actuators LH/RH and glass hatch lock actuator (unlock)	Output	OFF	OFF (neutral)	0V
					ON (unlock)	Battery voltage
67	B	Ground	Input	ON	—	0V
68	W/R	Power window power supply (RAP)	Output	—	Ignition switch ON	Battery voltage
					Within 45 seconds after ignition switch OFF	Battery voltage
					More than 45 seconds after ignition switch OFF	0V
					When front door LH or RH is open or power window timer operates	0V
69	L	Power window power supply	Output	—	—	Battery voltage
70	W	Battery power supply	Input	OFF	—	Battery voltage

1: With remote keyless entry system

2: With Intelligent Key system

## Self-Diagnosis (With CONSULT)

INFOID:000000007357065

### NOTE:

The Signal Tech II Tool (J-50190) can be used to perform the following functions. Refer to the Signal Tech II User Guide for additional information.

- Activate and display TPMS transmitter IDs
- Display tire pressure reported by the TPMS transmitter
- Read TPMS DTCs
- Register TPMS transmitter IDs

## FUNCTION

Self-Diagnostic Results Mode

# BCM (BODY CONTROL MODULE)

## < ECU DIAGNOSIS INFORMATION >

Diagnostic item	Diagnostic item is detected when ...	Reference page
LOW - PRESSURE - FL [C1704] LOW - PRESSURE - FR [C1705] LOW - PRESSURE - RR [C1706] LOW - PRESSURE - RL [C1707]	Tire pressures dropped below specified value. Refer to <a href="#">WT-8</a> , " <a href="#">System Description</a> ".	—
[NO-DATA] - FL [C1708] [NO-DATA] - FR [C1709] [NO-DATA] - RR [C1710] [NO-DATA] - RL [C1711]	Data from FL transmitter cannot be received. Data from FR transmitter cannot be received. Data from RR transmitter cannot be received. Data from RL transmitter cannot be received.	<a href="#">WT-14</a>
[CHECKSUM- ERR] - FL [C1712] [CHECKSUM- ERR] - FR [C1713] [CHECKSUM- ERR] - RR [C1714] [CHECKSUM- ERR] - RL [C1715]	Checksum data from FL transmitter is malfunctioning. Checksum data from FR transmitter is malfunctioning. Checksum data from RR transmitter is malfunctioning. Checksum data from RL transmitter is malfunctioning.	<a href="#">WT-16</a>
[PRESSDATA- ERR] - FL [C1716] [PRESSDATA- ERR] - FR [C1717] [PRESSDATA- ERR] - RR [C1718] [PRESSDATA- ERR] - RL [C1719]	Air pressure data from FL transmitter is malfunctioning. Air pressure data from FR transmitter is malfunctioning. Air pressure data from RR transmitter is malfunctioning. Air pressure data from RL transmitter is malfunctioning.	<a href="#">WT-18</a>
[CODE- ERR] - FL [C1720] [CODE- ERR] - FR [C1721] [CODE- ERR] - RR [C1722] [CODE- ERR] - RL [C1723]	Function code data from FL transmitter is malfunctioning. Function code data from FR transmitter is malfunctioning. Function code data from RR transmitter is malfunctioning. Function code data from RL transmitter is malfunctioning.	<a href="#">WT-16</a>
[BATT - VOLT - LOW] - FL [C1724] [BATT - VOLT - LOW] - FR [C1725] [BATT - VOLT - LOW] - RR [C1726] [BATT - VOLT - LOW] - RL [C1727]	Battery voltage of FL transmitter drops. Battery voltage of FR transmitter drops. Battery voltage of RR transmitter drops. Battery voltage of RL transmitter drops.	<a href="#">WT-16</a>
VHCL_SPEED_SIG_ERR [C1729]	Vehicle speed signal is in error.	<a href="#">WT-20</a>
IGN_CIRCUIT_OPEN [C1735]	Vehicle ignition signal is in error.	<a href="#">WT-21</a>

### NOTE:

Before performing the self-diagnosis, be sure to register the ID or else the actual malfunction location may be different from that displayed on CONSULT.

## Self-Diagnosis (Without CONSULT)

INFOID:000000007357066

### NOTE:

The Signal Tech II Tool (J-50190) can be used to perform the following functions. Refer to the Signal Tech II User Guide for additional information.

- Activate and display TPMS transmitter IDs
- Display tire pressure reported by the TPMS transmitter
- Read TPMS DTCs
- Register TPMS transmitter IDs

## SELF-DIAGNOSTIC PROCEDURE (WITHOUT CONSULT)

1. Turn ignition switch ON.
2. Ground the tire pressure warning check connector to initiate self diagnosis.
3. Compare the flashing pattern with the flash code chart below.

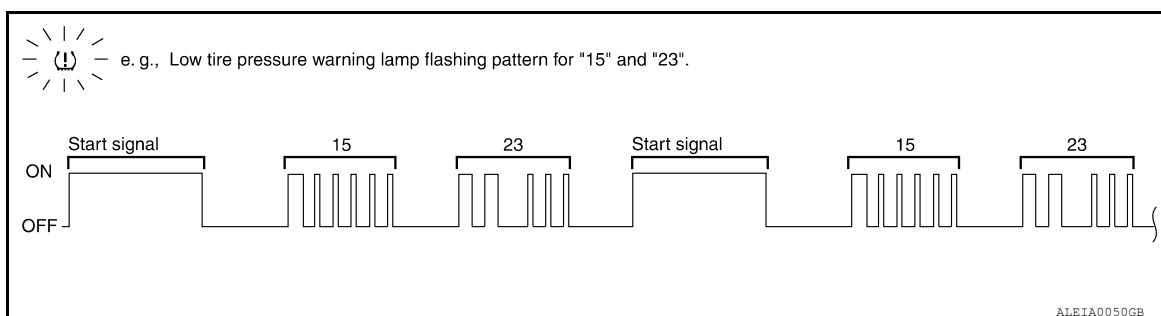

### NOTE:



## BCM (BODY CONTROL MODULE)

### < ECU DIAGNOSIS INFORMATION >

The system is normal when the low tire pressure warning lamp flashes 5 times and continues repeating. Self-diagnosis results are erased automatically by turning the ignition switch "OFF".

Flash Code	Malfunction part	Reference page
15 16 17 18	Tire pressure dropped below specified value. Refer to <a href="#">WT-8. "System Description"</a> .	—
21 22 23 24	Transmitter no data (FL) Transmitter no data (FR) Transmitter no data (RR) Transmitter no data (RL)	<a href="#">WT-14</a>
31 32 33 34	Transmitter checksum error (FL) Transmitter checksum error (FR) Transmitter checksum error (RR) Transmitter checksum error (RL)	<a href="#">WT-16</a>
35 36 37 38	Transmitter pressure data error (FL) Transmitter pressure data error (FR) Transmitter pressure data error (RR) Transmitter pressure data error (RL)	<a href="#">WT-18</a>
41 42 43 44	Transmitter function code error (FL) Transmitter function code error (FR) Transmitter function code error (RR) Transmitter function code error (RL)	<a href="#">WT-16</a>
45 46 47 48	Transmitter battery voltage low (FL) Transmitter battery voltage low (FR) Transmitter battery voltage low (RR) Transmitter battery voltage low (RL)	<a href="#">WT-16</a>
52	Vehicle speed signal	<a href="#">WT-20</a>
54	Vehicle ignition signal	<a href="#">WT-21</a>

A  
B  
C  
D  
WT  
F  
G  
H  
I  
J  
K  
L  
M  
N  
O  
P

# TIRE PRESSURE MONITORING SYSTEM

< WIRING DIAGRAM >

## WIRING DIAGRAM

### TIRE PRESSURE MONITORING SYSTEM

#### Wiring Diagram

INFOID:000000007357067

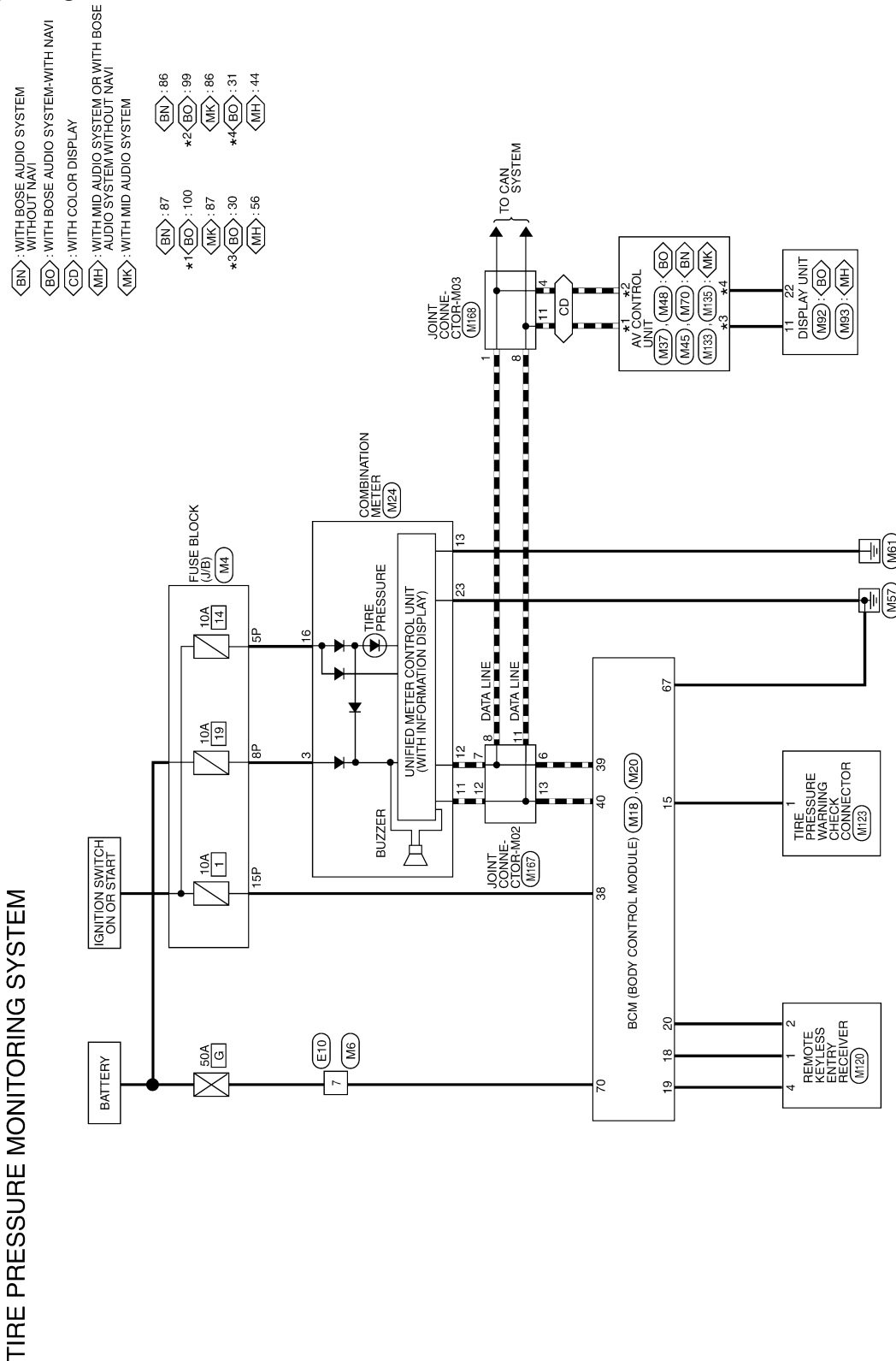

ABEWA0073GB

# TIRE PRESSURE MONITORING SYSTEM

< WIRING DIAGRAM >

## TIRE PRESSURE MONITORING SYSTEM CONNECTORS

Connector No.	M4
Connector Name	FUSE BLOCK (J/B)
Connector Color	WHITE



Terminal No.	Color of Wire	Signal Name
5P	W/G	-
8P	R/Y	-
15P	W/R	-

Connector No.	M6
Connector Name	WIRE TO WIRE
Connector Color	WHITE

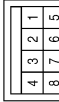

Terminal No.	Color of Wire	Signal Name
7	W	-

Connector No.	M18
Connector Name	BCM (BODY CONTROL MODULE)
Connector Color	WHITE

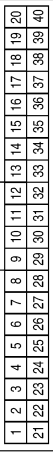

Terminal No.	Color of Wire	Signal Name
15	W	TPMS MODE TRIGGER SW
18	BR	KEYLESS AND AUTO LIGHT SENSOR GND
19	V	KEYLESS TUNER POWER SUPPLY OUTPUT
20	G	KEYLESS TUNER SIGNAL
38	W/R	IGN SW
39	L	CAN-H
40	P	CAN-L

Connector No.	M20
Connector Name	BCM (BODY CONTROL MODULE)
Connector Color	BLACK

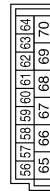

Terminal No.	Color of Wire	Signal Name
67	B	GND (POWER)
70	W	BAT (FL)

Connector No.	M24
Connector Name	COMBINATION METER
Connector Color	WHITE



Terminal No.	Color of Wire	Signal Name
3	R/Y	BATTERY
11	P	CAN-L
12	L	CAN-H
13	GR	GROUND
16	W/G	RUN START
23	B	POWER GND

Connector No.	M37
Connector Name	AV CONTROL UNIT (WITH BOSE AUDIO SYSTEM WITH NAVI)
Connector Color	WHITE

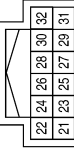

Terminal No.	Color of Wire	Signal Name
30	V	IT DISP
31	LG	DISP IT

A B C D E F G H I J K L M N O P

WT

# TIRE PRESSURE MONITORING SYSTEM

< WIRING DIAGRAM >

Connector No.	M45
Connector Name	AV CONTROL UNIT (WITH BOSE AUDIO SYSTEM WITHOUT NAVI)
Connector Color	WHITE

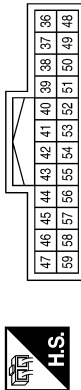

Terminal No.	Color of Wire	Signal Name
44	LG	DISP IT
56	V	IT DISP

Connector No.	M48
Connector Name	AV CONTROL UNIT (WITH BOSE AUDIO SYSTEM WITH NAVI)
Connector Color	WHITE

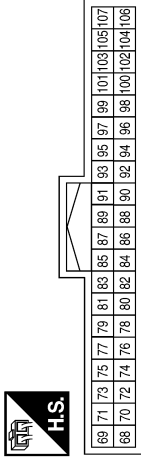

Terminal No.	Color of Wire	Signal Name
99	L	CAN-H
100	P	CAN-L

Connector No.	M70
Connector Name	AV CONTROL UNIT (WITH BOSE AUDIO SYSTEM WITHOUT NAVI)
Connector Color	WHITE

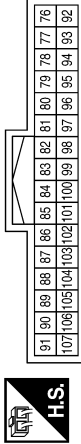

Terminal No.	Color of Wire	Signal Name
86	L	CAN-H
87	P	CAN-L

Connector No.	M92
Connector Name	DISPLAY UNIT (WITH NAVI)
Connector Color	WHITE

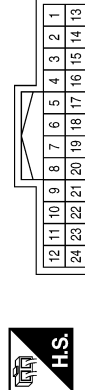

Terminal No.	Color of Wire	Signal Name
11	V	IT DISP
22	LG	DISP IT

Connector No.	M93
Connector Name	DISPLAY UNIT (WITHOUT NAVI)
Connector Color	WHITE

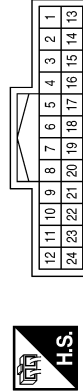

Terminal No.	Color of Wire	Signal Name
11	V	IT DISP
22	LG	DISP IT

Connector No.	M120
Connector Name	REMOTE KEYLESS ENTRY RECEIVER
Connector Color	WHITE



Terminal No.	Color of Wire	Signal Name
1	BR	GND
2	G	SIGNAL
3	-	-
4	V	PWR

# TIRE PRESSURE MONITORING SYSTEM

< WIRING DIAGRAM >

Connector No.	M123
Connector Name	TIRE PRESSURE WARNING CHECK CONNECTOR
Connector Color	WHITE



Terminal No.	Color of Wire	Signal Name
1	W	-

Connector No.	M133
Connector Name	AV CONTROL UNIT (WITH MID AUDIO SYSTEM)
Connector Color	WHITE

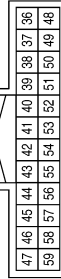

Terminal No.	Color of Wire	Signal Name
44	LG	DISP IT
56	V	IT DISP

Connector No.	M135
Connector Name	AV CONTROL UNIT (WITH MID AUDIO SYSTEM)
Connector Color	WHITE

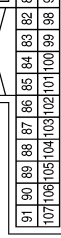

Terminal No.	Color of Wire	Signal Name
86	L	CAN-H
87	P	CAN-L

Connector No.	M167
Connector Name	JOINT CONNECTOR-M02
Connector Color	BLUE

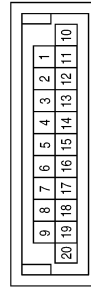

Terminal No.	Color of Wire	Signal Name
6	L	-
7	L	-
8	L	-
11	P	-
12	P	-
13	P	-

Connector No.	M168
Connector Name	JOINT CONNECTOR-M03
Connector Color	GREEN

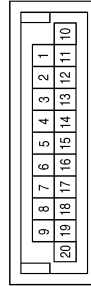

Terminal No.	Color of Wire	Signal Name
1	L	-
4	L	-
8	P	-
11	P	-

Connector No.	E10
Connector Name	WIRE TO WIRE
Connector Color	WHITE



Terminal No.	Color of Wire	Signal Name
7	W	-

ABEIA0130GB

A  
B  
C  
D  
WT  
F  
G  
H  
I  
J  
K  
L  
M  
N  
O  
P

# TPMS

< SYMPTOM DIAGNOSIS >

## SYMPTOM DIAGNOSIS

### TPMS

#### Symptom Table

INFOID:000000007357068

Symptom	Reference
Low tire pressure warning lamp does not come on when ignition switch is turned ON.	<a href="#">WT-39</a>
Low tire pressure warning lamp stays on when ignition switch is turned ON.	<a href="#">WT-40</a>
Low tire pressure warning lamp flashes when ignition switch is turned ON.	<a href="#">WT-41</a>
Hazard warning lamps flash when ignition switch is turned ON.	<a href="#">WT-42</a>
Tire pressure information in display unit does not exist.	<a href="#">WT-42</a>
ID registration cannot be completed.	<a href="#">WT-44</a>

# LOW TIRE PRESSURE WARNING LAMP DOES NOT TURN ON

< SYMPTOM DIAGNOSIS >

## LOW TIRE PRESSURE WARNING LAMP DOES NOT TURN ON

Low Tire Pressure Warning Lamp Does Not Come On When Ignition Switch Is Turned On

INFOID:000000007357069

### NOTE:

The Signal Tech II Tool (J-50190) can be used to perform the following functions. Refer to the Signal Tech II User Guide for additional information.

- Activate and display TPMS transmitter IDs
- Display tire pressure reported by the TPMS transmitter
- Read TPMS DTCs
- Register TPMS transmitter IDs

### DIAGNOSTIC PROCEDURE

#### 1. SELF-DIAGNOSTIC RESULT CHECK

Using CONSULT, check display contents of BCM in SELF-DIAGNOSIS.

Is CAN COMM CIRCUIT displayed in the self-diagnosis display items?

- YES >> Malfunction in CAN communication system.
- NO >> GO TO 2

#### 2. CHECK COMBINATION METER

Check combination meter operation. Refer to [MWI-27, "CONSULT Function \(METER/M&A\)"](#).

Is the inspection result normal?

- YES >> GO TO 3
- NO >> Replace combination meter. Refer to [MWI-89, "Removal and Installation"](#).

#### 3. CHECK LOW TIRE PRESSURE WARNING LAMP

Disconnect BCM harness connector.

Does the low tire pressure warning lamp activate?

- YES >> Replace BCM. Refer to [BCS-53, "Removal and Installation"](#).
- NO >> Check combination meter operation.

A  
B  
C  
D  
WT  
F  
G  
H  
I  
J  
K  
L  
M  
N  
O  
P

# LOW TIRE PRESSURE WARNING LAMP STAYS ON

< SYMPTOM DIAGNOSIS >

---

## LOW TIRE PRESSURE WARNING LAMP STAYS ON

Low Tire Pressure Warning Lamp Stays On When Ignition Switch Is Turned On

INFOID:000000007357070

### DIAGNOSTIC PROCEDURE

#### 1. BCM CONNECTORS

---

1. Turn ignition switch OFF.
2. Disconnect BCM harness connectors.
3. Check terminals for damage or loose connections.

Is the inspection result normal?

- YES >> GO TO 2  
NO >> Repair or replace damaged parts.

#### 2. BCM POWER SUPPLY AND GROUND CIRCUITS

---

Check BCM power supply and ground circuits. Refer to [BCS-30. "Diagnosis Procedure"](#).

Is the inspection result normal?

- YES >> Replace BCM. Refer to [BCS-53. "Removal and Installation"](#).  
NO >> Repair BCM circuits.



# LOW TIRE PRESSURE WARNING LAMP BLINKS

< SYMPTOM DIAGNOSIS >

## LOW TIRE PRESSURE WARNING LAMP BLINKS

Low Tire Pressure Warning Lamp Flashes When Ignition Switch Is Turned On

INFOID:000000007357071

Regarding Wiring Diagram information, refer to [WT-34. "Wiring Diagram"](#).

### NOTE:

If low tire pressure warning lamp flashes as shown, the system is normal.

Flash Mode A

- This mode shows transmitter status is OFF-mode.  
Carry out transmitter wake up operation. Refer to [WT-5. "Transmitter Wake Up Operation"](#).

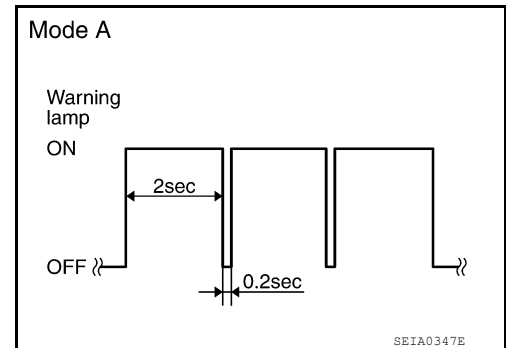

### DIAGNOSTIC PROCEDURE

#### 1. CHECK BCM CONNECTORS

1. Turn ignition switch OFF.
2. Disconnect BCM harness connectors.
3. Check terminals for damage or loose connections.

Is the inspection result normal?

- YES >> GO TO 2
- NO >> Repair or replace damaged parts.

#### 2. CHECK TIRE PRESSURE WARNING CHECK CONNECTOR CIRCUIT

Check continuity between BCM harness connector M18 terminal 15 and ground.

**Continuity should not exist.**

Is the inspection result normal?

- YES >> Replace BCM. Refer to [BCS-53. "Removal and Installation"](#).
- NO >> Repair circuit for short to ground.

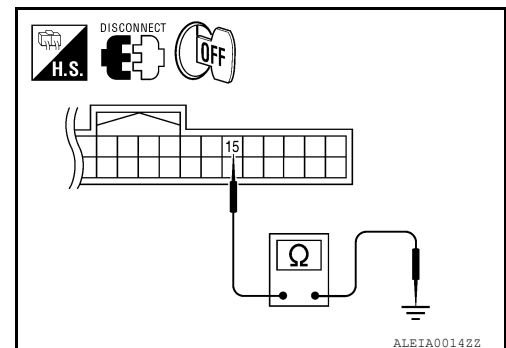

## HAZARD WARNING LAMPS FLASH

< SYMPTOM DIAGNOSIS >

---

### HAZARD WARNING LAMPS FLASH

Hazard Warning Lamps Flash When Ignition Switch Is Turned On

INFOID:000000007357072

#### DIAGNOSTIC PROCEDURE

#### 1. CHECK BCM GROUND CIRCUIT

---

Check BCM ground circuit. Refer to [BCS-30, "Diagnosis Procedure"](#).

Is the inspection result normal?

- YES >> Replace BCM. Refer to [BCS-53, "Removal and Installation"](#).
- NO >> Repair BCM ground circuit.

# "TIRE PRESSURE" INFORMATION IN DISPLAY UNIT DOES NOT EXIST

< SYMPTOM DIAGNOSIS >

## "TIRE PRESSURE" INFORMATION IN DISPLAY UNIT DOES NOT EXIST

"TIRE PRESSURE" Information in Display Unit Does Not Exist

INFOID:000000007357073

### NOTE:

The Signal Tech II Tool (J-50190) can be used to perform the following functions. Refer to the Signal Tech II User Guide for additional information.

- Activate and display TPMS transmitter IDs
- Display tire pressure reported by the TPMS transmitter
- Read TPMS DTCs
- Register TPMS transmitter IDs

### DIAGNOSTIC PROCEDURE

#### 1. SELF-DIAGNOSTIC RESULT CHECK

Using CONSULT, check display contents in self-diagnostic results.

Is CAN COMM CIRCUIT displayed in the self-diagnosis display items?

YES >> Malfunction in CAN communication system.

NO >> GO TO 2.

#### 2. CHECK DISPLAY UNIT

Perform AV unit self-diagnosis. Refer to [AV-306. "AV CONTROL UNIT : CONSULT Function"](#).

Is the inspection result normal?

OK >> Replace BCM. Refer to [BCS-53. "Removal and Installation"](#).

NG >> Repair or replace malfunctioning parts.

A  
B  
C  
D  
WT  
F  
G  
H  
I  
J  
K  
L  
M  
N  
O  
P

## ID REGISTRATION CANNOT BE COMPLETED

< SYMPTOM DIAGNOSIS >

---

### ID REGISTRATION CANNOT BE COMPLETED

#### ID Registration Cannot Be Completed

INFOID:000000007357074

**NOTE:**

The Signal Tech II Tool (J-50190) can be used to perform the following functions. Refer to the Signal Tech II User Guide for additional information.

- Activate and display TPMS transmitter IDs
- Display tire pressure reported by the TPMS transmitter
- Read TPMS DTCs
- Register TPMS transmitter IDs

#### DIAGNOSTIC PROCEDURE

##### 1. PERFORM ID REGISTRATION OF ALL TRANSMITTERS

---

Carry out ID registration of all transmitters. Refer to [WT-6, "ID Registration Procedure"](#).

Can ID registration of all transmitters be completed?

- YES >> Inspection End.  
NO >> GO TO [WT-14, "Diagnosis Procedure"](#).

# PRECAUTIONS

< PRECAUTION >

## PRECAUTION

### PRECAUTIONS

#### Precaution for Supplemental Restraint System (SRS) "AIR BAG" and "SEAT BELT PRE-TENSIONER"

INFOID:000000007357075

The Supplemental Restraint System such as "AIR BAG" and "SEAT BELT PRE-TENSIONER", used along with a front seat belt, helps to reduce the risk or severity of injury to the driver and front passenger for certain types of collision. This system includes seat belt switch inputs and dual stage front air bag modules. The SRS system uses the seat belt switches to determine the front air bag deployment, and may only deploy one front air bag, depending on the severity of a collision and whether the front occupants are belted or unbelted. Information necessary to service the system safely is included in the SR and SB section of this Service Manual.

#### **WARNING:**

- To avoid rendering the SRS inoperative, which could increase the risk of personal injury or death in the event of a collision which would result in air bag inflation, all maintenance must be performed by an authorized NISSAN/INFINITI dealer.
- Improper maintenance, including incorrect removal and installation of the SRS, can lead to personal injury caused by unintentional activation of the system. For removal of Spiral Cable and Air Bag Module, see the SR section.
- Do not use electrical test equipment on any circuit related to the SRS unless instructed to in this Service Manual. SRS wiring harnesses can be identified by yellow and/or orange harnesses or harness connectors.

#### PRECAUTIONS WHEN USING POWER TOOLS (AIR OR ELECTRIC) AND HAMMERS

#### **WARNING:**

- When working near the Airbag Diagnosis Sensor Unit or other Airbag System sensors with the Ignition ON or engine running, DO NOT use air or electric power tools or strike near the sensor(s) with a hammer. Heavy vibration could activate the sensor(s) and deploy the air bag(s), possibly causing serious injury.
- When using air or electric power tools or hammers, always switch the Ignition OFF, disconnect the battery, and wait at least 3 minutes before performing any service.

#### Precaution Necessary for Steering Wheel Rotation After Battery Disconnect

INFOID:000000007357076

#### **NOTE:**

- This Procedure is applied only to models with Intelligent Key system and NATS (NISSAN ANTI-THEFT SYSTEM).
- Remove and install all control units after disconnecting both battery cables with the ignition knob in the "LOCK" position.
- Always use CONSULT to perform self-diagnosis as a part of each function inspection after finishing work. If DTC is detected, perform trouble diagnosis according to self-diagnostic results.

For models equipped with the Intelligent Key system and NATS, an electrically controlled steering lock mechanism is adopted on the key cylinder.

For this reason, if the battery is disconnected or if the battery is discharged, the steering wheel will lock and steering wheel rotation will become impossible.

If steering wheel rotation is required when battery power is interrupted, follow the procedure below before starting the repair operation.

#### OPERATION PROCEDURE

1. Connect both battery cables.

#### **NOTE:**

Supply power using jumper cables if battery is discharged.

2. Use the Intelligent Key or mechanical key to turn the ignition switch to the "ACC" position. At this time, the steering lock will be released.
3. Disconnect both battery cables. The steering lock will remain released and the steering wheel can be rotated.
4. Perform the necessary repair operation.

## PRECAUTIONS

### < PRECAUTION >

---

5. When the repair work is completed, return the ignition switch to the "LOCK" position before connecting the battery cables. (At this time, the steering lock mechanism will engage.)
6. Perform a self-diagnosis check of all control units using CONSULT.

### Precaution for Road Wheel

INFOID:000000007829926

- Genuine NISSAN aluminum wheel is designed for each type of vehicle. Use it on the specified vehicle only.
- Use Genuine NISSAN parts for the wheel nuts.
- Always adjusting the wheel balance prior to using them. For the balance weights, use Genuine NISSAN aluminum wheel weights.
- Use caution when handling the aluminum wheels, because they can be easily scratched. When removing dirt, do not use any abrasives, a wire brush, or other items that may scratch the coating. Use a neutral detergent if a detergent is needed.
- After driving on roads scattered with anti-icing salts, wash off the wheels completely.
- When installing road wheels onto the vehicle, always wipe off any dirt or foreign substances to prevent them from being trapped between the contact surfaces of wheel.
- Never apply oil to nut and bolt threads.

# PREPARATION

< PREPARATION >

## PREPARATION

### PREPARATION

#### Special Service Tool

INFOID:000000007357078

The actual shapes of Kent-Moore tools may differ from those of special service tools illustrated here.

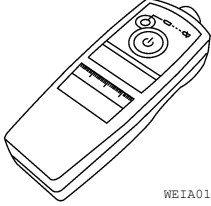
Tool number (Kent-Moore No.) Tool name	Description
KV991B1000 (J-45295) Transmitter activation tool   <p style="text-align: center;">WEIA0144E</p>	<ul style="list-style-type: none"> <li>• Transmitter wake up operation</li> <li>• ID registration procedure</li> </ul>

#### Commercial Service Tool

INFOID:000000007357079

Tool name	Description
Power tool   <p style="text-align: center;">PIIB1407E</p>	Loosening nuts, screws and bolts

A  
B  
C  
D  
WT  
F  
G  
H  
I  
J  
K  
L  
M  
N  
O  
P

# NOISE, VIBRATION, AND HARSHNESS (NVH) TROUBLESHOOTING

< SYMPTOM DIAGNOSIS >

## SYMPTOM DIAGNOSIS

### NOISE, VIBRATION, AND HARSHNESS (NVH) TROUBLESHOOTING

#### NVH Troubleshooting Chart

INFOID:000000007357080

Use chart below to help you find the cause of the symptom. If necessary, repair or replace these parts.

Symptom		Possible cause and SUSPECTED PARTS		Reference page														
				WT-49	WT-50, "Adjustment"	WT-55	WT-50	—	—	WT-55	DLN-350, "NVH Troubleshooting Chart" (R180A), DLN-385, "NVH Troubleshooting Chart" (M205)	DLN-418, "NVH Troubleshooting Chart" (R200), DLN-455, "NVH Troubleshooting Chart" (R230)	FAX-5, "NVH Troubleshooting Chart" (FAX) FSU-6, "NVH Troubleshooting Chart" (FSU)	RAX-5, "NVH Troubleshooting Chart" (RAX) RSU-5, "NVH Troubleshooting Chart" (RSU)	Refer to TIRES in this chart.	Refer to ROAD WHEEL in this chart.	BR-6, "NVH Troubleshooting Chart"	ST-11, "NVH Troubleshooting Chart"
TIRES	Noise	x	x	x	x	x	x	x	x	x	x	x	x	x	x	x	x	
	Shake	x	x	x	x	x	x	x	x	x	x	x	x	x	x	x	x	
	Vibration			x					x			x	x				x	
	Shimmy	x	x	x	x	x	x	x	x			x	x	x	x	x	x	
	Shudder	x	x	x	x	x	x	x	x			x	x	x	x	x	x	
	Poor quality ride or handling	x	x	x	x	x	x	x	x			x	x	x				
	ROAD WHEEL	Noise	x	x			x				x	x	x	x		x	x	x
		Shake	x	x									x	x		x	x	x
		Shimmy, shudder	x	x					x				x	x		x	x	x
		Poor quality ride or handling	x	x					x				x	x		x		

x: Applicable



# WHEEL

< PERIODIC MAINTENANCE >

## PERIODIC MAINTENANCE

### WHEEL

#### Inspection

INFOID:000000007357081

#### ALUMINUM WHEEL

1. Check tires for wear and improper inflation.
2. Check wheels for deformation, cracks and other damage. If deformed, remove wheel and check wheel runout.

**CAUTION:**

**DO NOT use center hole cone-type clamping machines to hold the wheel assembly during tire removal/installation or balancing or damage to the wheel paint, cladding or chrome may result. Use only rim-type or universal lug-type clamping machines to hold the wheel assembly during servicing.**

- a. Remove tire from wheel and mount wheel on a tire balance machine.
- b. Set dial indicator as shown. Refer to [WT-55, "Road Wheel"](#).
3. Check front wheel bearings for looseness.
4. Check front suspension for looseness.

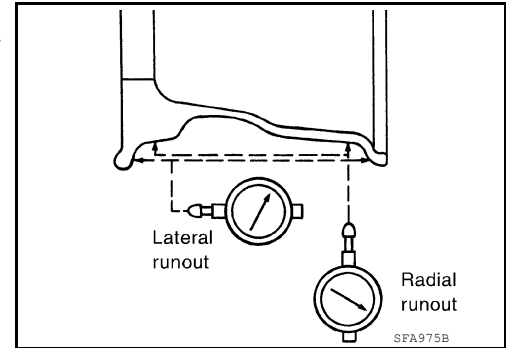

#### STEEL WHEEL

1. Check tires for wear and improper inflation.
  2. Check wheels for deformation, cracks, and other damage. If deformed, remove wheel and check wheel runout.
- a. Remove tire from steel wheel and mount on a tire balance machine.
  - b. Set two dial indicators as shown.
  - c. Set each dial indicator to 0.
  - d. Rotate wheel and check dial indicators at several points around the circumference of the wheel.
  - e. Calculate runout at each point as shown.

$$\text{Radial runout} = (A+B)/2$$

$$\text{Lateral runout} = (C+D)/2$$

- f. Select maximum positive runout value and the maximum negative value.

Add the two values to determine total runout. In case a positive or negative value is not available, use the maximum value (negative or positive) for total runout. If the total runout value exceeds the limit, replace the steel wheel.

**Wheel runout : Refer to [WT-55, "Road Wheel"](#).**

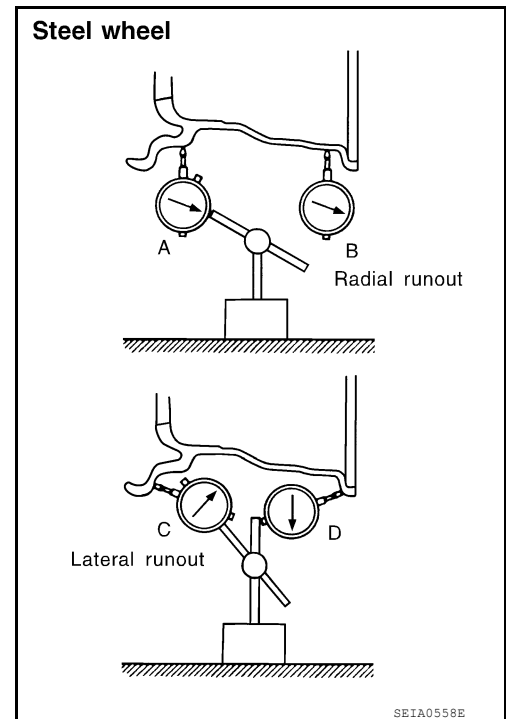

# WHEEL AND TIRE ASSEMBLY

< PERIODIC MAINTENANCE >

## WHEEL AND TIRE ASSEMBLY

### Adjustment

INFOID:000000007357082

#### BALANCING WHEELS (ADHESIVE WEIGHT TYPE)

##### Preparation Before Adjustment

Remove inner and outer balance weights from the road wheel using releasing agent. Remove double-faced adhesive tape from the road wheel.

##### CAUTION:

- **Be careful not to scratch the road wheel during removal.**
- **After removing double-faced adhesive tape, wipe clean all traces of releasing agent from the road wheel.**

##### Wheel Balance Adjustment

- If a balancer machine has an adhesive weight mode setting, select the adhesive weight mode setting and skip Step 2. below. If a balancer machine only has the clip-on (rim flange) weight mode setting, follow Step 2. to calculate the correct size adhesive weight.

1. Set road wheel on balancer machine using the center hole as a guide. Start the balancer machine.
2. For balancer machines that only have a clip-on (rim flange) weight mode setting, follow this step to calculate the correct size adhesive weight to use. When inner and outer imbalance values are shown on the balancer machine indicator, multiply outer imbalance value by 5/3 (1.67) to determine balance weight that should be used. Select the outer balance weight with a value closest to the calculated value above and install in to the designated outer position of, or at the designated angle in relation to the road wheel.

- a. Indicated imbalance value  $\times 5/3 =$  balance weight to be installed

##### Calculation example:

$23 \text{ g (0.81 oz)} \times 5/3 (1.67) = 38.33 \text{ g (1.35 oz)} \Rightarrow 40 \text{ g (1.41 oz)}$   
balance weight (closer to calculated balance weight value)

##### NOTE:

Note that balance weight value must be closer to the calculated balance weight value.

##### Example:

$37.4 \Rightarrow 35 \text{ g (1.23 oz)}$

$37.5 \Rightarrow 40 \text{ g (1.41 oz)}$

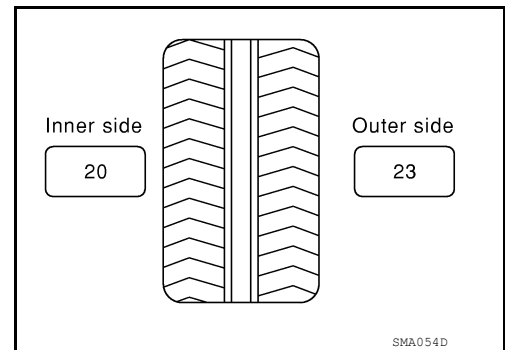

3. Install balance weight in the position shown.

##### CAUTION:

- **Do not install the inner balance weight before installing the outer balance weight.**
- **Before installing the balance weight, be sure to clean the mating surface of the road wheel.**
- When installing balance weight (1) to road wheel, set it into the grooved area (A) on the inner wall of the road wheel as shown so that the balance weight center (B) is aligned with the balancer machine indication position (angle) (C).

##### CAUTION:

- **Always use genuine NISSAN adhesive balance weights.**
- **Balance weights are non-reusable; always replace with new ones.**
- **Do not install more than three sheets of balance weight.**

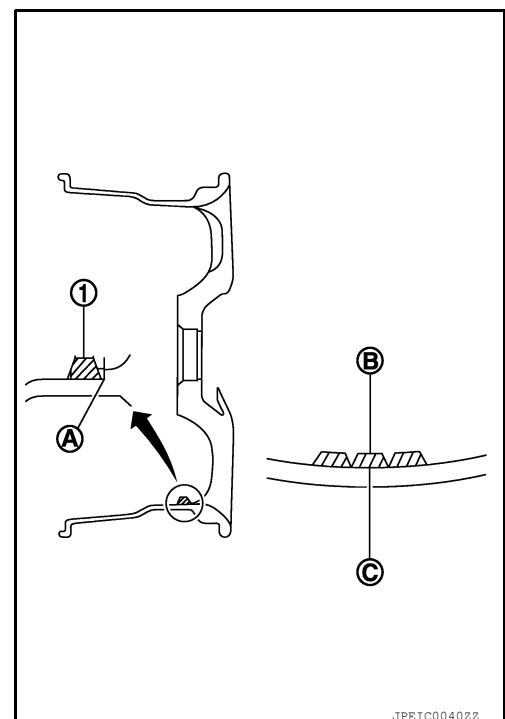

# WHEEL AND TIRE ASSEMBLY

## < PERIODIC MAINTENANCE >

4. If calculated balance weight value exceeds 50 g (1.76 oz), install two balance weight sheets in line with each other as shown.  
**CAUTION:**  
**Do not install one balance weight sheet on top another.**
5. Start balancer machine again.
6. Install balance weight on inner side of road wheel in the balancer machine indication position (angle).  
**CAUTION:**  
**Do not install more than two balance weights.**
7. Start balancer machine. Make sure that inner and outer residual imbalance values are 5 g (0.17 oz) each or below.
8. If either residual imbalance value exceeds 5 g (0.17 oz), repeat installation procedures.

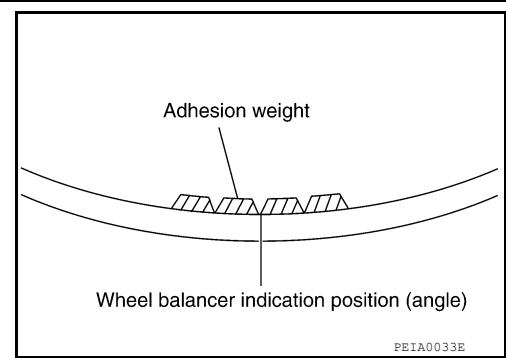

Wheel balance	Dynamic (At flange)	Static (At flange)
Maximum allowable imbalance	Refer to <a href="#">WT-55, "Road Wheel"</a> .	

## TIRE ROTATION

- Follow the maintenance schedule for tire rotation service intervals. Refer to [MA-11, "FOR USA AND CANADA : Introduction to Periodic Maintenance"](#) (United States and Canada), or [MA-15, "FOR MEXICO : Periodic Maintenance Schedule"](#) (Mexico).
- When installing the wheel, tighten wheel nuts to the specified torque.  
**CAUTION:**
  - Do not include the spare tire when rotating the tires.
  - When installing wheels, tighten them diagonally by dividing the work two to three times in order to prevent the wheels from developing any distortion.
  - Be careful not to tighten wheel nut at torque exceeding the criteria for preventing strain of disc rotor.
  - Use NISSAN genuine wheel nuts for aluminum wheels.

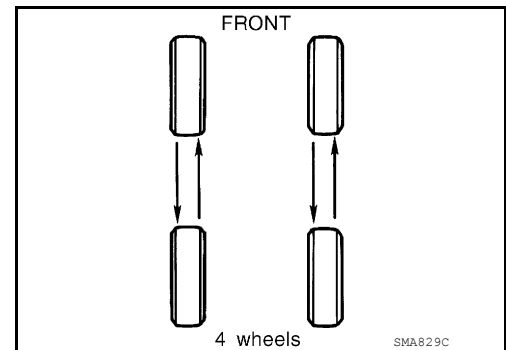

**Wheel nut tightening torque : 133 N·m (14 kg-m, 98 ft-lb)**

- Perform the ID registration, after tire rotation. Refer to [WT-6, "ID Registration Procedure"](#).

# REMOVAL AND INSTALLATION

< REMOVAL AND INSTALLATION >

## REMOVAL AND INSTALLATION

### REMOVAL AND INSTALLATION

#### Exploded View

INFOID:000000008807317

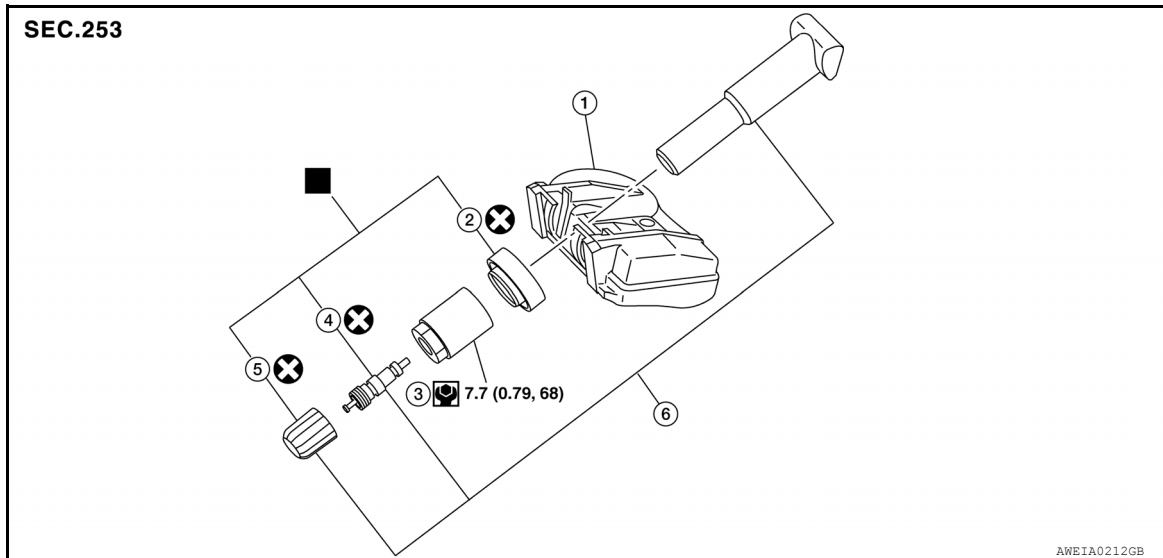

- |  |              |                        |
|--|--------------|------------------------|
| 1. Transmitter (tire pressure sensor)                          | 2. O-ring    | 3. Valve stem nut      |
| 4. Valve core  | 5. Valve cap | 6. Valve stem assembly |
| ■: Parts that are replaced as a set when the tire is replaced. |              |                        |

#### Transmitter (Pressure Sensor)

INFOID:000000007357083

#### REMOVAL

1. Remove road wheel and tire assembly using power tool.
2. Remove valve cap and valve core to deflate the tire.

#### NOTE:

If the tire is to be reused, apply a matching mark on the tire in line with the position of the road wheel valve stem assembly for the purpose of road wheel and tire balance adjustment after installation.

3. Remove the valve stem nut and allow transmitter to fall into tire.

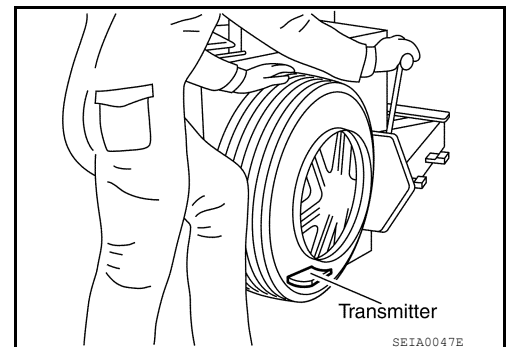

4. Lubricate the tire outside bead well with a suitable non-silicone lubricant, and remove outside of tire from the road wheel. Reach inside the tire and remove the transmitter.

#### CAUTION:

- Do not use silicone lubricant. Use of silicone lubricant will deteriorate the tire and road wheel.
- Be sure not to damage the road wheel or transmitter.
- Do not allow lubricant to make contact with transmitter.

5. Lubricate the tire inside bead well with a suitable non-silicone lubricant, and remove inside of tire from the road wheel.

# REMOVAL AND INSTALLATION

## < REMOVAL AND INSTALLATION >

### CAUTION:

- Do not use silicone lubricant. Use of silicone lubricant will deteriorate the tire and road wheel.
- Be sure not to damage the road wheel.

6. Remove the valve stem from the transmitter as shown.

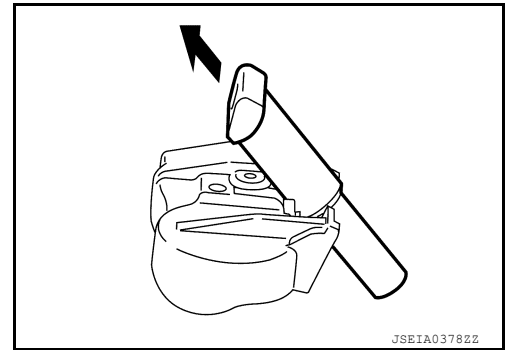

## INSTALLATION

1. Apply a suitable non-silicone lubricant to the tire inside bead.

### CAUTION:

- Do not use silicone lubricant. Use of silicone lubricant will deteriorate the tire and wheel.

2. Install the tire inside bead (1) onto the road wheel (2) in the position shown.

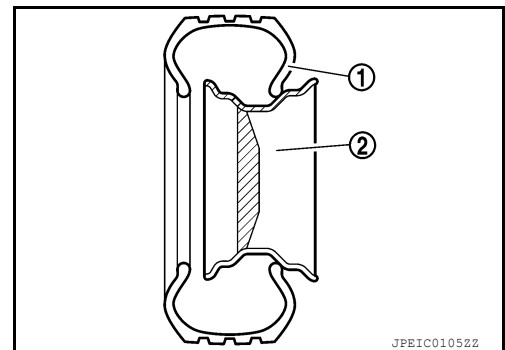

3. Install the valve stem to the transmitter.

4. Install the O-ring to the transmitter.

### CAUTION:

- Do not reuse O-ring
- Insert O-ring to the base of the transmitter.
- The base of the valve stem (A) must be positioned in the groove of the metal plate as shown.

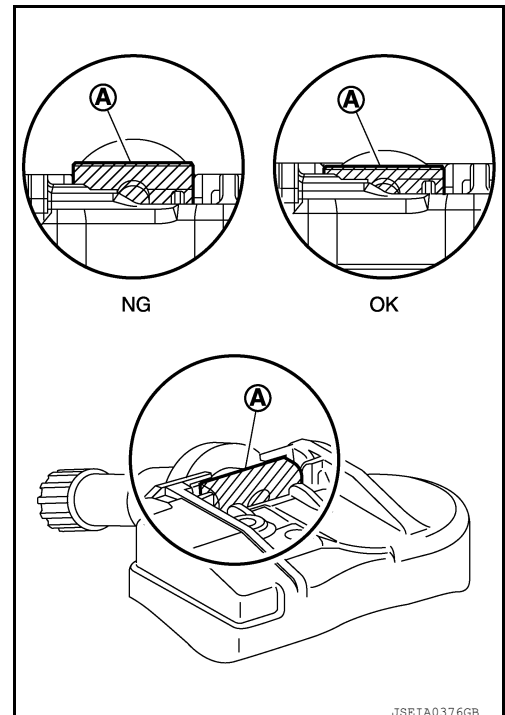

A  
B  
C  
D  
WT  
F  
G  
H  
I  
J  
K  
L  
M  
N  
O  
P

## REMOVAL AND INSTALLATION

### < REMOVAL AND INSTALLATION >

5. Install transmitter (1) to road wheel while pressing at position (A).

**CAUTION:**

- Check that O-ring contacts horizontally with road wheel.
- Check that the base of the valve stem is positioned in the groove of the metal plate.

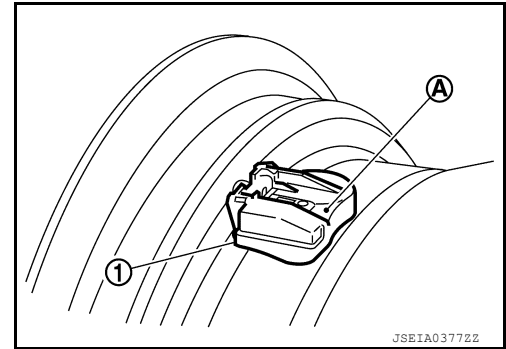

6. Install and tighten the valve stem nut to the specified torque.

**Valve stem nut tightening torque** : 7.7 N·m (0.79 kg-m, 68 in-lb)

**CAUTION:**

**Do not use power tool for installation.**

7. Place wheel on turntable of tire machine. Ensure that transmitter is 270 degrees from mounting/dismounting head.

**NOTE:**

Do not touch transmitter with mounting head.

8. Apply a suitable non-silicone lubricant to the tire outside bead.

**CAUTION:**

- Do not use silicone lubricant. Use of silicone lubricant will deteriorate the tire and wheel.
- Do not allow lubricant to make contact with transmitter.

9. Install the tire outside bead onto the road wheel as normal.

**NOTE:**

If the tire is being reused, align the matching mark applied on the tire with the position of the road wheel valve stem assembly for the purpose of road wheel and tire balance adjustment after installation. Ensure that the tire does not rotate relative to road wheel.

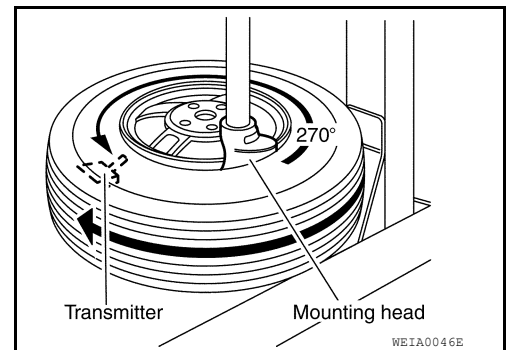

10. Install the valve core and inflate tire.

**CAUTION:**

**Do not reuse valve core.**

11. Install the valve cap.

**CAUTION:**

**Do not reuse valve cap.**

12. Inflate tire and balance the wheel and tire assembly. Refer to [WT-50, "Adjustment"](#).

13. Install wheel and tire assembly in appropriate wheel position on vehicle. Refer to [WT-50, "Adjustment"](#).

**NOTE:**

If replacing the transmitter, then transmitter wake up operation must be performed. Refer to [WT-5, "Transmitter Wake Up Operation"](#).

14. Adjust neutral position of steering angle sensor. Refer to [BRC-121, "ADJUSTMENT OF STEERING ANGLE SENSOR NEUTRAL POSITION : Special Repair Requirement"](#).

## SERVICE DATA AND SPECIFICATIONS (SDS)

< SERVICE DATA AND SPECIFICATIONS (SDS)

# SERVICE DATA AND SPECIFICATIONS (SDS)

## SERVICE DATA AND SPECIFICATIONS (SDS)

### Road Wheel

INFOID:000000007357084

Wheel type		Aluminum	Steel	
			Inside	Outside
Maximum radial runout limit	Lateral mm (in)	0.3 (0.012) or less	1.0 (0.039) or less	0.9 (0.035) or less
	Radial mm (in)	0.3 (0.012) or less	0.8 (0.031) or less	0.4 (0.016) or less
Maximum allowable imbalance	Dynamic (at rim flange)	Less than 5 g (0.18 oz) (per side)		
	Static (at rim flange)	Less than 10 g (0.35 oz)		

### Tire

INFOID:000000007357085

Unit: kPa (kg/cm<sup>2</sup>, psi)

Tire size	Air pressure	
	Conventional tire	Spare tire
P245/75R16	240 (2.4, 35)	240 (2.4, 35)
P265/65R17	240 (2.4, 35)	240 (2.4, 35)
P265/60R18	240 (2.4, 35)	240 (2.4, 35)

A  
B  
C  
D  
WT  
F  
G  
H  
I  
J  
K  
L  
M  
N  
O  
P