

A
B
C

SECTION **WW**

WIPER & WASHER

CONTENTS

BASIC INSPECTION	3	Component Function Check	20	F
DIAGNOSIS AND REPAIR WORKFLOW	3	Diagnosis Procedure	20	
Work Flow	3	FRONT WIPER AUTO STOP SIGNAL CIRCUIT	22	G
SYSTEM DESCRIPTION	4	Component Function Check	22	
FRONT WIPER AND WASHER SYSTEM	4	Diagnosis Procedure	22	H
System Diagram	4	FRONT WIPER MOTOR GROUND CIRCUIT ...	24	
System Description	4	Diagnosis Procedure	24	
Component Parts Location	7	WASHER SWITCH	25	I
Component Description	7	Description	25	
REAR WIPER AND WASHER SYSTEM	8	Component Inspection	25	J
System Diagram	8	WASHER MOTOR CIRCUIT	27	
System Description	8	Diagnosis Procedure	27	
Component Parts Location	10	REAR WIPER MOTOR CIRCUIT	29	K
Component Description	10	Component Function Check	29	
DIAGNOSIS SYSTEM (BCM)	11	Diagnosis Procedure	29	
COMMON ITEM	11	REAR WIPER AUTO STOP SIGNAL CIRCUIT	31	M
COMMON ITEM : CONSULT Function (BCM - COMMON ITEM)	11	Component Function Check	31	
WIPER	12	Diagnosis Procedure	31	
WIPER : CONSULT Function (BCM - WIPER)	12	ECU DIAGNOSIS INFORMATION	32	N
DIAGNOSIS SYSTEM (IPDM E/R)	13	BCM (BODY CONTROL MODULE)	32	
Diagnosis Description	13	Reference Value	32	
CONSULT Function (IPDM E/R)	15	Terminal Layout	35	
DTC/CIRCUIT DIAGNOSIS	17	Physical Values	35	O
WIPER AND WASHER FUSE	17	Fail Safe	40	
Description	17	DTC Inspection Priority Chart	40	
Diagnosis Procedure	17	DTC Index	41	P
FRONT WIPER MOTOR LO CIRCUIT	18	IPDM E/R (INTELLIGENT POWER DISTRIBUTION MODULE ENGINE ROOM)	43	
Component Function Check	18	Reference Value	43	
Diagnosis Procedure	18	Terminal Layout	44	
FRONT WIPER MOTOR HI CIRCUIT	20	Physical Values	45	



Fail Safe	48	PRECAUTION	68
DTC Index	49	Precaution for Supplemental Restraint System (SRS) "AIR BAG" and "SEAT BELT PRE-TENSIONER"	68
WIRING DIAGRAM	50	Precaution Necessary for Steering Wheel Rotation After Battery Disconnect	68
FRONT WIPER AND WASHER SYSTEM	50	REMOVAL AND INSTALLATION	70
Wiring Diagram	50	FRONT WIPER AND WASHER SYSTEM	70
REAR WIPER AND WASHER SYSTEM	55	Removal and Installation	70
Wiring Diagram	55	Washer Nozzle Adjustment	74
SYMPTOM DIAGNOSIS	62	REAR WIPER AND WASHER SYSTEM	75
WIPER AND WASHER SYSTEM SYMPTOMS		Removal and Installation	75
Symptom Table	62	Rear Washer Nozzle Adjustment	78
NORMAL OPERATING CONDITION	65	SERVICE DATA AND SPECIFICATIONS (SDS)	79
Description	65	SERVICE DATA AND SPECIFICATIONS (SDS)	79
FRONT WIPER DOES NOT OPERATE	66	Specifications	79
Description	66		
Diagnosis Procedure	66		
PRECAUTION	68		

DIAGNOSIS AND REPAIR WORKFLOW

< BASIC INSPECTION >

BASIC INSPECTION

DIAGNOSIS AND REPAIR WORKFLOW

Work Flow

INFOID:000000007355258

DETAILED FLOW

1. LISTEN TO CUSTOMER COMPLAINT

Listen to customer complaint. Get detailed information about the conditions and environment when the symptom occurs.

>> GO TO 2

2. VERIFY THE SYMPTOM WITH OPERATIONAL CHECK

Verify the symptom with operational check. Refer to [PCS-9, "Diagnosis Description"](#).

>> GO TO 3

3. GO TO APPROPRIATE TROUBLE DIAGNOSIS

Go to appropriate trouble diagnosis. Refer to [WW-62, "Symptom Table"](#).

>> GO TO 4

4. REPAIR OR REPLACE

Repair or replace the specific parts.

>> GO TO 5

5. FINAL CHECK

Final check.

Is inspection result normal?

YES >> Inspection End.

NO >> Refer to [GI-37, "Intermittent Incident"](#).

A
B
C
D
E
F
G
H
I
J
K
M
N
O
P

WW

FRONT WIPER AND WASHER SYSTEM

< SYSTEM DESCRIPTION >

SYSTEM DESCRIPTION

FRONT WIPER AND WASHER SYSTEM

System Diagram

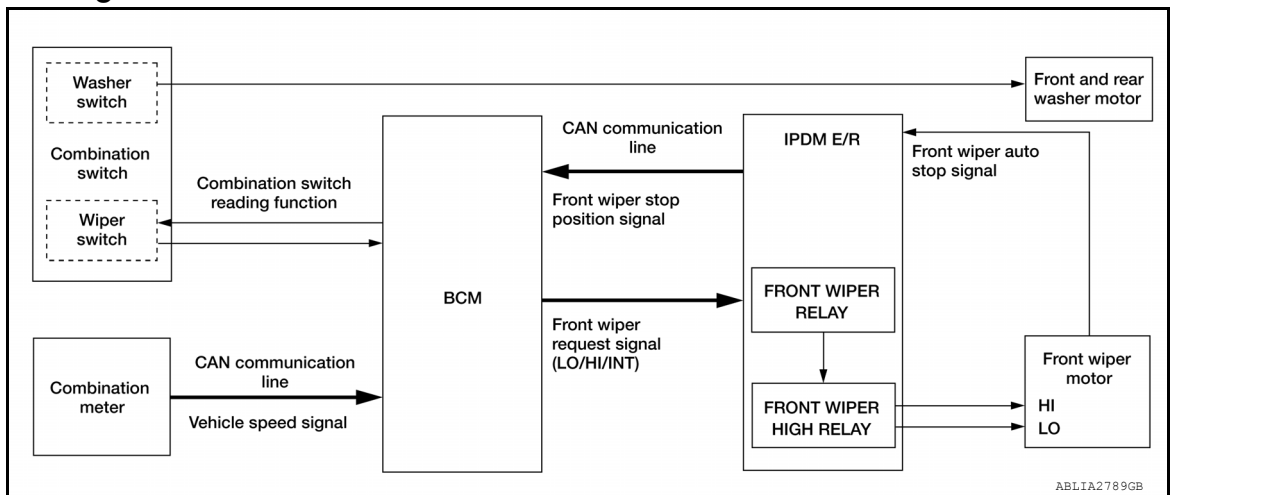

System Description

INFOID:000000007355260

OUTLINE

The front wiper is controlled by each function of BCM and IPDM E/R.

Control by BCM

- Combination switch reading function
- Front wiper control function

Control by IPDM E/R

- Front wiper control function
- Relay control function

FRONT WIPER BASIC OPERATION

- BCM detects the combination switch condition by the combination switch reading function.
- BCM transmits the front wiper request signal to IPDM E/R with CAN communication depending on each operating condition of the front wiper.
- IPDM E/R turns ON/OFF the integrated front wiper relay and the front wiper high relay according to the front wiper request signal. IPDM E/R provides the power supply to operate the front wiper HI/LO operation.

FRONT WIPER LO OPERATION

- BCM transmits the front wiper request signal (LO) to IPDM E/R with CAN communication according to the front wiper LO operating condition.

Front wiper LO operating condition

- Ignition switch ON
- Front wiper switch LO or front wiper switch MIST (while pressing)
- IPDM E/R turns ON the integrated front wiper relay according to the front wiper request signal (LO).

FRONT WIPER HI OPERATION

- BCM transmits the front wiper request signal (HI) to IPDM E/R with CAN communication according to the front wiper HI operating condition.

Front wiper HI operating condition

- Ignition switch ON
- Front wiper switch HI
- IPDM E/R turns ON the integrated front wiper relay and the front wiper high relay according to the front wiper request signal (HI).

FRONT WIPER INT OPERATION (LINKED WITH VEHICLE SPEED)

FRONT WIPER AND WASHER SYSTEM

< SYSTEM DESCRIPTION >

- BCM transmits the front wiper request signal (INT) to IPDM E/R with CAN communication according to the front wiper INT operation condition and the intermittent operation delay interval judged value.

Front wiper INT operating condition

- Ignition switch ON
- Front wiper switch INT

Intermittent operation delay interval judgment

- BCM calculates the intermittent operation delay interval from the vehicle speed signal received from the wiper dial position and the combination meter with CAN communication.

Wiper intermittent dial position	Intermittent operation interval	Intermittent operation delay Interval (s)			
		Vehicle speed			
		Vehicle stopped or less than 5 km/h (3.1 MPH)	5 km/h (3.1 MPH) or more or less than 35 km/h (21.7 MPH)	35 km/h (21.7 MPH) or more or less than 65 km/h (40.4 MPH)	65 km/h (40.4 MPH) or more
1	Short ↑	0.8	0.6	0.4	0.24
2		4	3	2	1.2
3		10	7.5	5	3
4		16	12	8	4.8
5		24	18	12	7.2
6	Long ↓	32	24	16	9.6
7		42	31.5	21	12.6

- IPDM E/R turns the integrated front wiper relay ON so that the front wiper is operated only once according to the front wiper request signal (INT).
- BCM detects stop position/except stop position of the front wiper motor according to the front wiper stop position signal received from IPDM E/R with CAN communication.
- BCM transmits the front wiper request signal (INT) again after the intermittent operation delay interval after the front wiper motor is stopped.

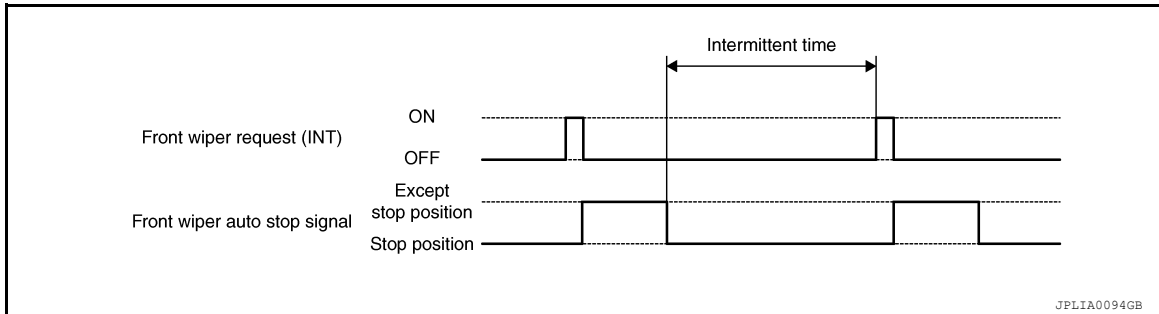

FRONT WIPER AUTO STOP OPERATION

- BCM stops transmitting the front wiper request signal when the front wiper switch is turned OFF.
- IPDM E/R detects the front wiper auto stop signal from the front wiper motor and detects the front wiper motor position (stop position/except stop position).

FRONT WIPER AND WASHER SYSTEM

< SYSTEM DESCRIPTION >

- When the front wiper request signal is stopped, IPDM E/R turns ON the front wiper relay until the front wiper motor returns to the stop position.

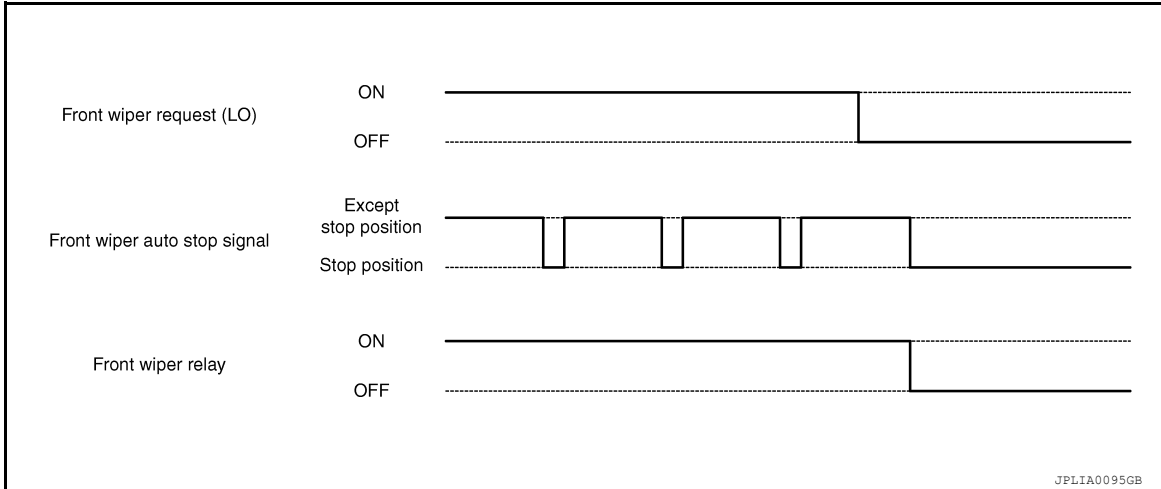

NOTE:

- BCM stops the transmitting of the front wiper request signal when the ignition switch is OFF.
- IPDM E/R turns the front wiper relay OFF when the ignition switch is OFF.

FRONT WIPER OPERATION LINKED WITH WASHER

- BCM transmits the front wiper request signal (LO) to IPDM E/R with CAN communication according to the washer linked operating condition of the front wiper.
- BCM transmits the front wiper request signal (LO) so that the front wiper operates approximately 3 times when the front washer switch OFF is detected.

Washer linked operating condition of front wiper

- Ignition switch ON
- Front washer switch ON (0.4 second or more)
- IPDM E/R turns ON the integrated front wiper relay according to the front wiper request signal (LO).
- The front and rear washer motor is grounded through the combination switch with the front washer switch ON.

FRONT WIPER DROP WIPE OPERATION

- BCM controls the front wiper to operate once according to the conditions of front wiper drop wipe operation.

Front wiper drop wipe operating condition

- Ignition switch ON
- Front wiper switch OFF
- Front washer switch OFF
- BCM transmits the front wiper request signal (LO) to IPDM E/R with CAN communication so that the front wiper operate once three seconds after front wiper operation linked with washer.
- IPDM E/R turns ON the integrated front wiper relay according to the front wiper request signal (LO).

FRONT WIPER FAIL-SAFE OPERATION

- IPDM E/R performs the fail-safe function when the front wiper auto stop circuit is malfunctioning. Refer to [PCS-20, "Fail Safe"](#).

FRONT WIPER AND WASHER SYSTEM

< SYSTEM DESCRIPTION >

Component Parts Location

INFOID:000000007355261

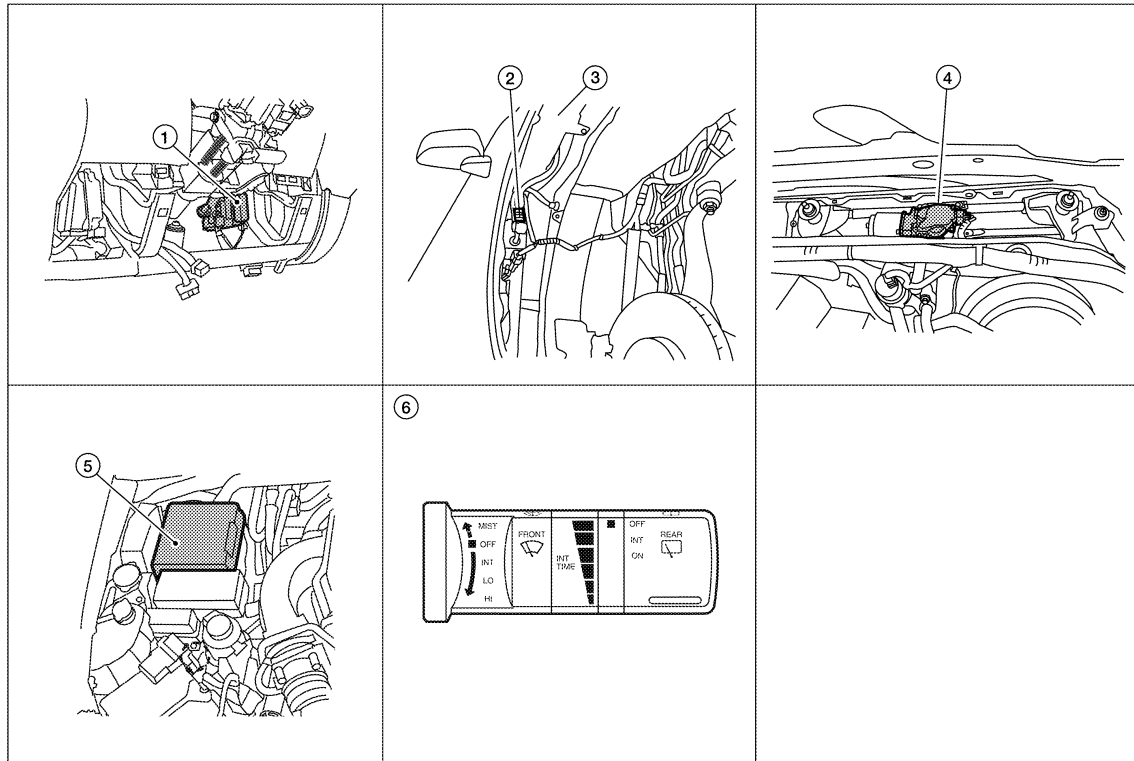

1. BCM M18, M20 (view with instrument lower panel LH removed)
2. Front and rear washer motor E105
3. Washer fluid reservoir
4. Front wiper motor E23 (view with cowl top removed)
5. IPDM E/R E121, E122, E124
6. Combination switch M28 (wiper and washer switch)

ALLIA06172Z

Component Description

INFOID:000000007355262

Part	Description
BCM	<ul style="list-style-type: none"> Judges each switch status by the combination switch reading function. Requests (with CAN communication) the front wiper relay and the front wiper high relay ON to IPDM E/R.
IPDM E/R	<ul style="list-style-type: none"> Controls the integrated relay according to the request (with CAN communication) from BCM. Performs the auto stop control of the front wiper.
Combination switch (Wiper and washer switch)	Refer to WW-4, "System Diagram" .
Combination meter	Transmits the vehicle speed signal to BCM with CAN communication.
Front wiper motor	<ul style="list-style-type: none"> IPDM E/R controls front wiper operation. Sends wiper stop signal to IPDM E/R.
Front and rear washer motor	Pumps washer fluid to the front or rear in wash mode.

A
B
C
D
E
F
G
H
I
J
K

WW

M
N
O
P

REAR WIPER AND WASHER SYSTEM

< SYSTEM DESCRIPTION >

REAR WIPER AND WASHER SYSTEM

System Diagram

INFOID:000000007355263

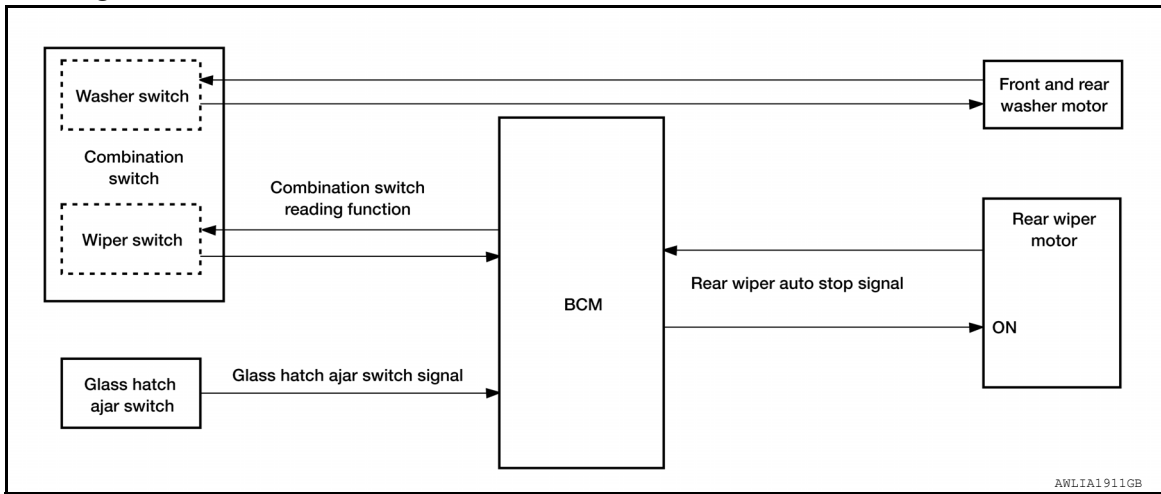

AWLIA1911GB

System Description

INFOID:000000007355264

OUTLINE

The rear wiper is controlled by each function of BCM.

Control by BCM

- Combination switch reading function
- Rear wiper control function

REAR WIPER BASIC OPERATION

- BCM detects the combination switch condition by the combination switch reading function.
- BCM detects the glass hatch ajar switch open before supplying power to the rear wiper.
- BCM controls the rear wiper to start or stop.

REAR WIPER ON OPERATION

- BCM supplies power to the rear wiper motor according to the rear wiper ON operating condition.

Rear wiper ON operating condition

- Ignition switch ON
- Rear wiper switch ON

REAR WIPER INT OPERATION

- BCM supplies power to the rear wiper motor according to the INT operating condition.

Rear wiper INT operating condition

- Ignition switch ON
- Rear wiper switch INT
- BCM controls the rear wiper to operate once.
- BCM detects the rear wiper motor stopping position.
- BCM supplies power to the rear wiper motor after an intermittent from the stop of the rear wiper motor.

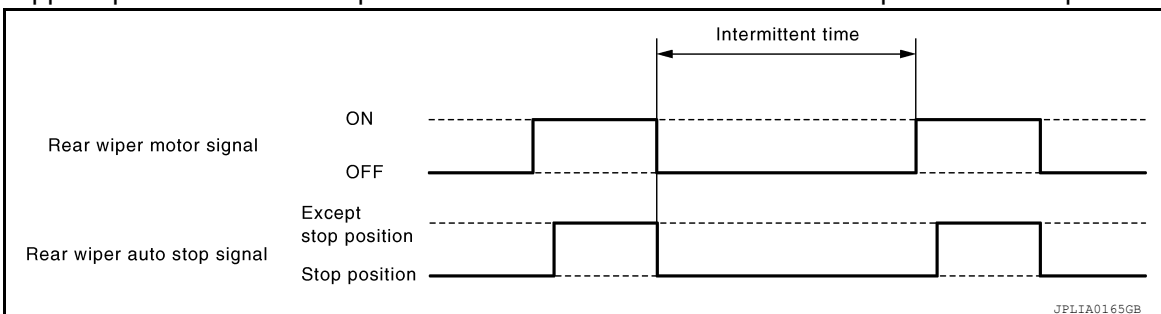

JPLIA0165GB

REAR WIPER AUTO STOP OPERATION

REAR WIPER AND WASHER SYSTEM

< SYSTEM DESCRIPTION >

- BCM stops supplying power to the rear wiper motor when the rear wiper switch is turned OFF.
- BCM reads an auto stop signal from the rear wiper motor to detect a rear wiper motor position.
- When the rear wiper motor is at other than the stopping position, BCM continues to supply power to the rear wiper motor until it returns to the stopping position.

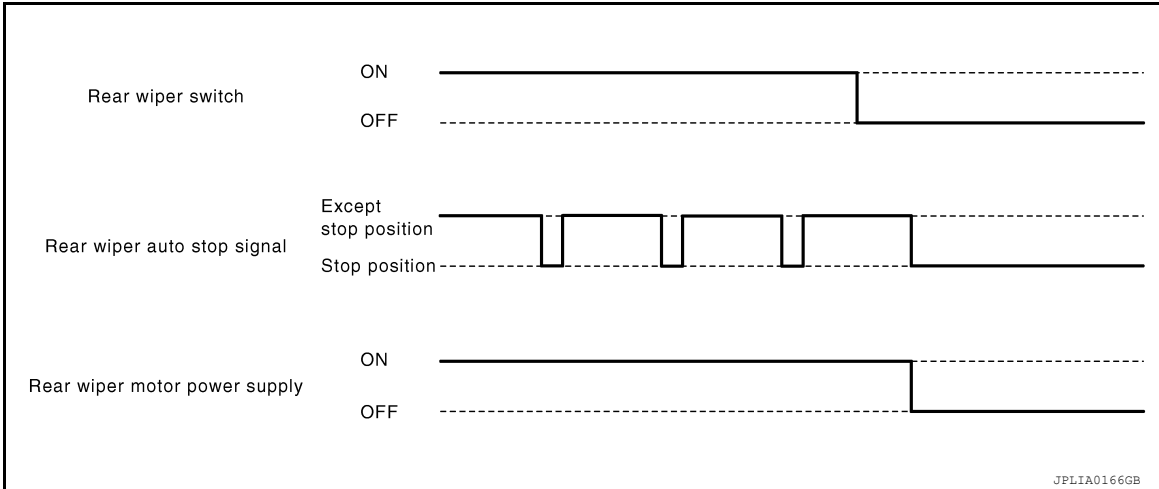

NOTE:

BCM stops supplying power to the rear wiper motor when the ignition switch is turned OFF.

REAR WIPER OPERATION LINKED WITH WASHER

- BCM supplies power to the rear wiper motor according to the washer linked operating condition of rear wiper. When the rear washer switch is turned OFF, BCM controls rear wiper to operate approximately three times.

Washer linked operating condition of rear wiper

- Ignition switch ON
- Rear washer switch ON (0.4 second or more)
- Front and rear washer motor becomes grounded through the combination switch (wiper and washer switch) when the rear washer switch is turned ON.

REAR WIPER DROP WIPE OPERATION

- BCM controls the rear wiper to operate once according to the rear wiper drop wipe operating condition.

Rear wiper drop wipe operating condition

- Ignition switch ON
- Rear wiper switch OFF
- Rear washer switch OFF
- BCM controls the rear wiper so that it operates once time approximately three seconds later after the washer interlocking operation of the rear wiper.

REAR WIPER FAIL-SAFE OPERATION

BCM performs the fail-safe function when the rear wiper auto stop circuit is malfunctioning. Refer to [BCS-43](#). "[Fail Safe](#)".

REAR WIPER AND WASHER SYSTEM

< SYSTEM DESCRIPTION >

Component Parts Location

INFOID:000000007355265

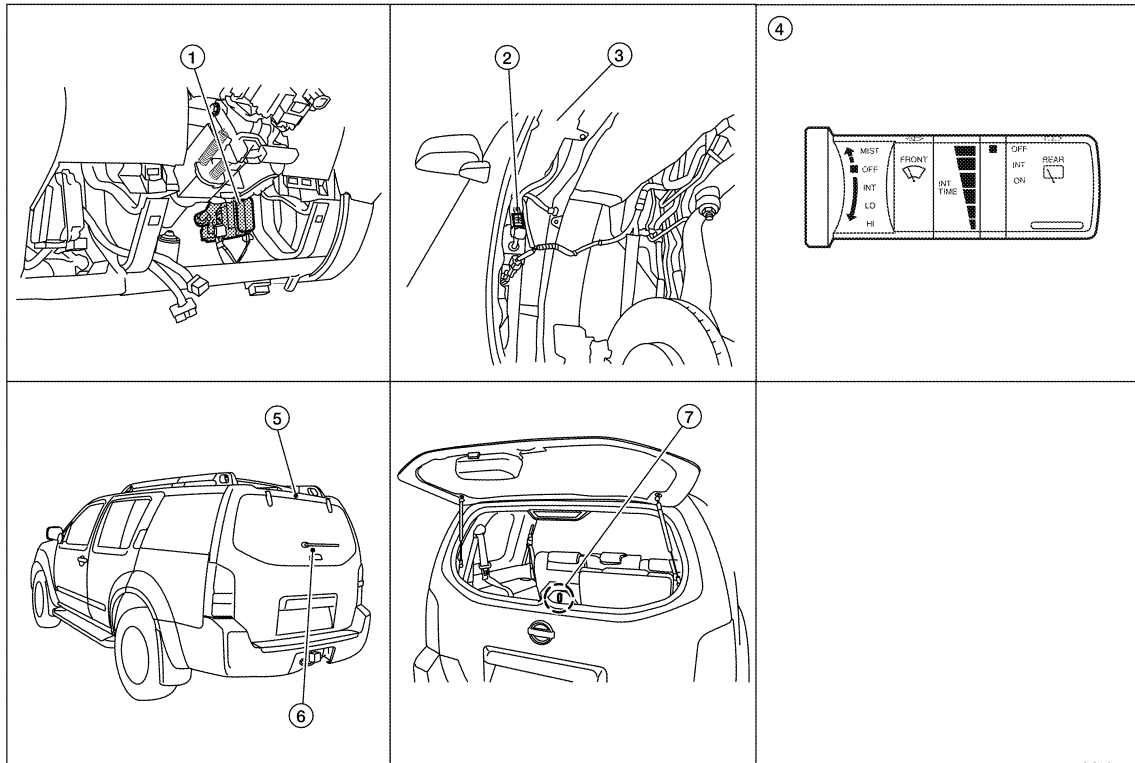

ALLIAR06182Z

- | | | |
|--|---|---------------------------|
| 1. BCM M18, M19, M20 (view with instrument lower panel LH removed) | 2. Front and rear washer motor connector E105 | 3. Washer fluid reservoir |
| 4. Combination switch M28 (wiper and washer switch) | 5. Rear wiper nozzle | 6. Rear wiper motor D602 |
| 7. Glass hatch ajar switch D503 | | |

Component Description

INFOID:000000007355266

Part	Description
BCM	<ul style="list-style-type: none"> Judges each switch status by the combination switch reading function. Supplies power to the rear wiper motor. Performs the auto stop control of the rear wiper.
Combination switch (Wiper and washer switch)	Refer to WW-8. "System Diagram" .
Rear wiper motor	<ul style="list-style-type: none"> BCM controls rear wiper operation. Sends wiper stop signal to BCM.
Front and rear washer motor	Pumps washer fluid to front or rear in wash mode.
Glass hatch ajar switch	Provides BCM with the glass hatch open/closed status to operate rear wiper.

DIAGNOSIS SYSTEM (BCM)

< SYSTEM DESCRIPTION >

DIAGNOSIS SYSTEM (BCM) COMMON ITEM

COMMON ITEM : CONSULT Function (BCM - COMMON ITEM)

INFOID:000000007830025

APPLICATION ITEM

CONSULT performs the following functions via CAN communication with BCM.

Direct Diagnostic Mode	Description
Ecu Identification	The BCM part number is displayed.
Self Diagnostic Result	The BCM self diagnostic results are displayed.
Data Monitor	The BCM input/output data is displayed in real time.
Active Test	The BCM activates outputs to test components.
Work support	The settings for BCM functions can be changed.
Configuration	<ul style="list-style-type: none"> • The vehicle specification can be read and saved. • The vehicle specification can be written when replacing BCM.
CAN Diag Support Mntr	The result of transmit/receive diagnosis of CAN communication is displayed.

SYSTEM APPLICATION

BCM can perform the following functions.

System	Sub System	Direct Diagnostic Mode						
		Ecu Identification	Self Diagnostic Result	Data Monitor	Active Test	Work support	Configuration	CAN Diag Support Mntr
Door lock	DOOR LOCK			x	x	x		
Rear window defogger	REAR DEFOGGER			x	x			
Warning chime	BUZZER			x	x			
Interior room lamp timer	INT LAMP			x	x	x		
Remote keyless entry system	MULTI REMOTE ENT			x	x	x		
Exterior lamp	HEAD LAMP			x	x	x		
Wiper and washer	WIPER			x	x	x		
Turn signal and hazard warning lamps	FLASHER			x	x			
Air conditioner	AIR CONDITIONER			x				
Intelligent Key system	INTELLIGENT KEY			x				
Combination switch	COMB SW			x				
BCM	BCM	x	x			x	x	x
Immobilizer	IMMU		x	x	x			
Interior room lamp battery saver	BATTERY SAVER			x	x	x		
Back door open	TRUNK			x	x			
Vehicle security system	THEFT ALM			x	x	x		
RAP system	RETAINED PWR			x	x	x		
Signal buffer system	SIGNAL BUFFER			x	x			
TPMS	AIR PRESSURE MONITOR		x	x	x	x		
Panic alarm system	PANIC ALARM				x			

DIAGNOSIS SYSTEM (BCM)

< SYSTEM DESCRIPTION >

WIPER

WIPER : CONSULT Function (BCM - WIPER)

INFOID:000000007830026

DATA MONITOR

Monitor Item [Unit]	Description
IGN ON SW [On/Off]	Indicates condition of ignition switch ON position.
IGN SW CAN [On/Off]	Indicates ignition switch ON signal received from IPDM E/R on CAN communication line.
FR WIPER HI [On/Off]	Indicates condition of front wiper operation of combination switch.
FR WIPER LOW [On/Off]	
FR WIPER INT [On/Off]	
FR WASHER SW [On/Off]	
INT VOLUME [1 - 7]	
FR WIPER STOP [On/Off]	Indicates front wiper motor auto stop signal received from IPDM E/R on CAN communication line.
VEHICLE SPEED [km/h/mph]	Indicates vehicle speed signal received from combination meter on CAN communication line.
RR WIPER ON [On/Off]	Indicates condition of rear wiper operation of combination switch.
RR WIPER INT [On/Off]	
RR WASHER SW [On/Off]	
RR WIPER STOP [On/Off]	Indicates rear wiper motor auto stop input from rear wiper motor.

ACTIVE TEST

Test Item	Description
FR WIPER	This test is able to check front wiper operation [Off/INT/Lo/Hi].
RR WIPER	This test is able to check rear wiper operation [Off/On].

WORK SUPPORT

Support Item	Setting	Description
WIPER SPEED SETTING	Off*	Front wiper intermittent time linked with wiper dial position.
	On	Front wiper intermittent time linked with vehicle speed and wiper dial position.

* : Initial setting

DIAGNOSIS SYSTEM (IPDM E/R)

< SYSTEM DESCRIPTION >

DIAGNOSIS SYSTEM (IPDM E/R)

Diagnosis Description

INFOID:000000007830033

AUTO ACTIVE TEST

Description

In auto active test mode, the IPDM E/R sends a drive signal to the following systems to check their operation.

- Oil pressure low warning indicator
- Oil pressure gauge
- Rear window defogger
- Front wipers
- Tail, license and parking lamps
- Front fog lamps (if equipped)
- Headlamps (Hi, Lo)
- A/C compressor (magnetic clutch)
- Cooling fan

Operation Procedure

1. Close the hood and front door RH, and lift the wiper arms from the windshield (to prevent windshield damage due to wiper operation).
NOTE:
When auto active test is performed with hood opened, sprinkle water on windshield before hand.
2. Turn ignition switch OFF.
3. Turn the ignition switch ON and, within 20 seconds, press the front door switch LH 10 times. Then turn the ignition switch OFF.
4. Turn the ignition switch ON within 10 seconds. After that the horn sounds once and the auto active test starts.
5. After a series of the following operations is repeated 3 times, auto active test is completed.

NOTE:

When auto active test mode has to be cancelled halfway through test, turn ignition switch OFF.

CAUTION:

- If auto active test mode cannot be actuated, check door switch system. Refer to [DLK-56, "Description"](#) (with Intelligent Key system), [DLK-229, "Description"](#) (without Intelligent Key system).
- Do not start the engine.

Inspection in Auto Active Test Mode

When auto active test mode is actuated, the following 7 steps are repeated 3 times.

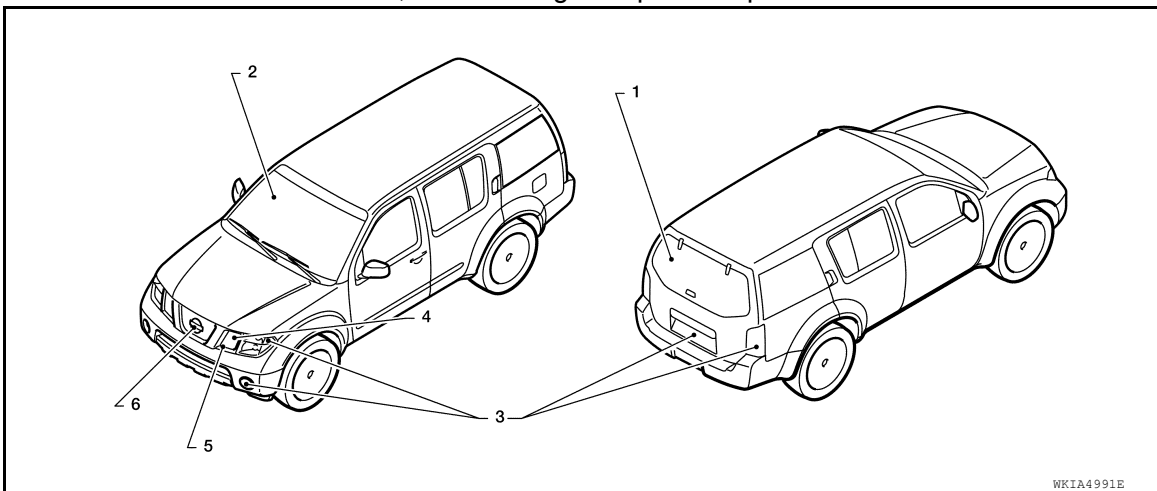

Operation sequence	Inspection Location	Operation
1	Rear window defogger	10 seconds
2	Front wipers	LO for 5 seconds → HI for 5 seconds

A
B
C
D
E
F
G
H
I
J
K
M
N
O
P

WW

DIAGNOSIS SYSTEM (IPDM E/R)

< SYSTEM DESCRIPTION >

Operation sequence	Inspection Location	Operation
3	Tail, license, front fog and parking lamps	10 seconds
4	Headlamps	LO for 10 seconds → HI on-off for 5 seconds
5	A/C compressor (magnetic clutch)	ON ↔ OFF 5 times
6	Cooling fan	10 seconds

Concept of auto active test

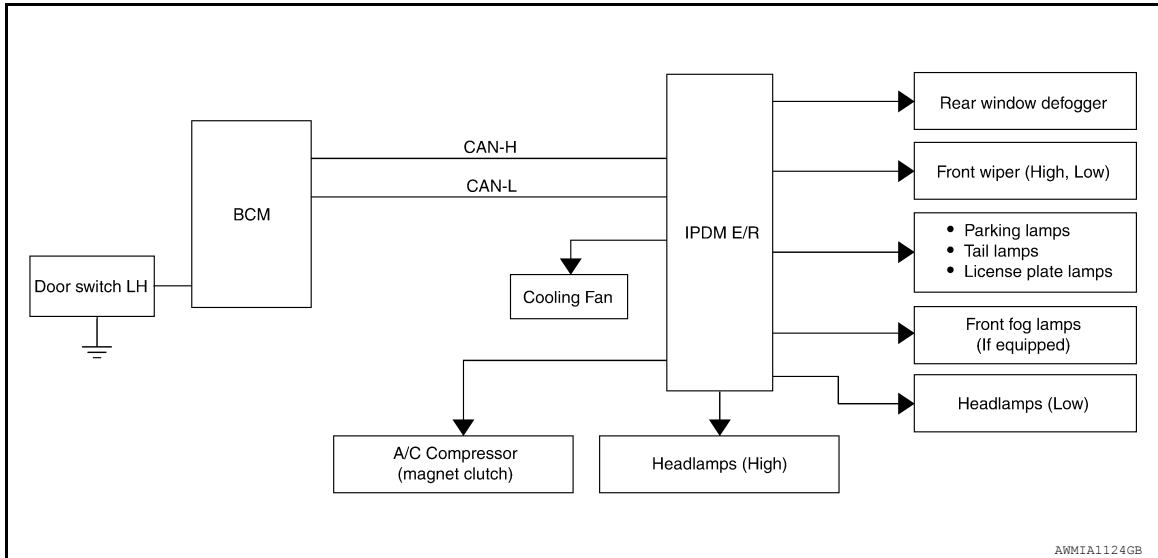

- IPDM E/R starts the auto active test with the door switch signals transmitted by BCM via CAN communication. Therefore, the CAN communication line between IPDM E/R and BCM is considered normal if the auto active test starts successfully.
- The auto active test facilitates troubleshooting if any systems controlled by IPDM E/R cannot be operated.

Diagnosis chart in auto active test mode

Symptom	Inspection contents	Possible cause
Oil pressure low warning indicator does not operate	Perform auto active test. Does the oil pressure low warning indicator operate?	YES • IPDM E/R signal input circuit • ECM signal input circuit • CAN communication signal between ECM and combination meter
		NO • CAN communication signal between IPDM E/R, BCM and combination meter
Oil pressure gauge does not operate	Perform auto active test. Does the oil pressure gauge operate?	YES IPDM E/R signal input circuit
		NO • CAN communication signal between IPDM E/R, BCM and combination meter
Rear window defogger does not operate	Perform auto active test. Does the rear window defogger operate?	YES BCM signal input circuit
		NO • Harness or connector between A/C and AV switch assembly and AV control unit • CAN communication signal between BCM and IPDM E/R

DIAGNOSIS SYSTEM (IPDM E/R)

< SYSTEM DESCRIPTION >

Symptom	Inspection contents	Possible cause	
Any of the following components do not operate <ul style="list-style-type: none"> • Front wipers • Tail lamps • License plate lamps • Parking lamps • Front fog lamps (if equipped) • Headlamps (Hi, Lo) 	Perform auto active test. Does the applicable system operate?	YES	BCM signal input system
		NO	<ul style="list-style-type: none"> • Lamp or front wiper motor malfunction • Lamp or front wiper motor ground circuit • Harness or connector between IPDM E/R and applicable system • IPDM E/R (integrated relay malfunction)
A/C compressor does not operate	Perform auto active test. Does the A/C compressor operate?	YES	<ul style="list-style-type: none"> • BCM signal input circuit • CAN communication signal between BCM and ECM • CAN communication signal between ECM and IPDM E/R
		NO	<ul style="list-style-type: none"> • Magnetic clutch malfunction • Harness or connector between IPDM E/R and magnetic clutch • IPDM E/R (integrated relay malfunction)
Cooling fan does not operate	Perform auto active test. Does the cooling fan operate?	YES	<ul style="list-style-type: none"> • ECM signal input circuit • CAN communication signal between ECM and IPDM E/R
		NO	<ul style="list-style-type: none"> • Cooling fan motor malfunction • Harness or connector between IPDM E/R and cooling fan • IPDM E/R (integrated relay malfunction)

CONSULT Function (IPDM E/R)

INFOID:000000007830034

APPLICATION ITEM

CONSULT performs the following functions via CAN communication with IPDM E/R.

Direct Diagnostic Mode	Description
Self Diagnostic Result	The IPDM E/R self diagnostic results are displayed.
Data Monitor	The IPDM E/R input/output data is displayed in real time.
Active Test	The IPDM E/R activates outputs to test components.
CAN Diag Support Mntr	The result of transmit/receive diagnosis of CAN communication is displayed.

SELF DIAGNOSTIC RESULT

Refer to [WW-49, "DTC Index"](#).

DATA MONITOR

Monitor Item [Unit]	Main Signals	Description
MOTOR FAN REQ [1/2/3/4]	×	Indicates cooling fan speed signal received from ECM on CAN communication line
AC COMP REQ [On/Off]	×	Indicates A/C compressor request signal received from ECM on communication line

DIAGNOSIS SYSTEM (IPDM E/R)

< SYSTEM DESCRIPTION >

Monitor Item [Unit]	Main Signals	Description
TAIL&CLR REQ [On/Off]	×	Indicates position light request signal received from BCM on CAN communication line
HL LO REQ [On/Off]	×	Indicates low beam request signal received from BCM on CAN communication line
HL HI REQ [On/Off]	×	Indicates high beam request signal received from BCM on CAN communication line
FR FOG REQ [On/Off]	×	Indicates front fog light request signal received from BCM on CAN communication line
FR WIP REQ [Stop/1LOW/Low/Hi]	×	Indicates front wiper request signal received from BCM on CAN communication line
WIP AUTO STOP [STOP P/ACT P]	×	Indicates condition of front wiper auto stop signal
WIP PROT [Off/BLOCK]	×	Indicates condition of front wiper fail-safe operation
ST RLY REQ [On/Off]		Indicates starter request signal received from ECM on CAN communication line
IGN RLY [On/Off]	×	Indicates condition of ignition relay
RR DEF REQ [On/Off]	×	Indicates rear defogger request signal received from BCM on CAN communication line
OIL P SW [Open/Close]		Indicates condition of oil pressure switch
DTRL REQ [Off]		Indicates daytime light request signal received from BCM on CAN communication line
THFT HRN REQ [On/Off]		Indicates theft warning horn request signal received from BCM on CAN communication line
HORN CHIRP [On/Off]		Indicates horn reminder signal received from BCM on CAN communication line

ACTIVE TEST

Test item	Description
REAR DEFOGGER	This test is able to check rear defogger operation [On/Off].
FRONT WIPER	This test is able to check wiper motor operation [Hi/Lo/Off].
MOTOR FAN	This test is able to check cooling fan operation [4/3/2/1].
EXTERNAL LAMPS	This test is able to check external lamp operation [Fog/Hi/Lo/TAIL/Off].
HORN	This test is able to check horn operation [On].

WIPER AND WASHER FUSE

< DTC/CIRCUIT DIAGNOSIS >

DTC/CIRCUIT DIAGNOSIS

WIPER AND WASHER FUSE

Description

INFOID:000000007355271

Fuse list

Unit	Location	Fuse No.	Capacity
Front wiper motor	IPDM E/R	39	30 A
Front and rear washer motor	Fuse block (J/B)	15	10 A

Diagnosis Procedure

INFOID:000000007355272

1. CHECK FUSES

Check that the following fuses are not blown.

Unit	Location	Fuse No.	Capacity
Front wiper motor	IPDM E/R	39	30 A
Front and rear washer motor	Fuse block (J/B)	15	10 A

Is the fuse blown?

- YES >> Replace the fuse after repairing the affected circuit.
- NO >> The fuse is normal.

A
B
C
D
E
F
G
H
I
J
K
M
N
O
P

WW

FRONT WIPER MOTOR LO CIRCUIT

< DTC/CIRCUIT DIAGNOSIS >

FRONT WIPER MOTOR LO CIRCUIT

Component Function Check

INFOID:000000007355273

1. CHECK FRONT WIPER LO OPERATION

⊗ IPDM E/R AUTO ACTIVE TEST

1. Start IPDM E/R auto active test. Refer to [PCS-9, "Diagnosis Description"](#).
2. Check that the front wiper operates at the LO operation.

Ⓟ WITH CONSULT ACTIVE TEST

1. Select "FRONT WIPER" of IPDM E/R active test item.
2. While operating the test item, check front wiper operation.

LO : Front wiper (LO) operation

OFF : Stop the front wiper.

Is front wiper (LO) operation normal?

- YES >> Front wiper motor LO circuit is normal.
 NO >> Refer to [WW-18, "Diagnosis Procedure"](#).

Diagnosis Procedure

INFOID:000000007355274

Regarding Wiring Diagram information, refer to [WW-50, "Wiring Diagram"](#).

1. CHECK FRONT WIPER MOTOR FUSE

1. Turn the ignition switch OFF.
2. Check that the following fuse is not blown.

Unit	Location	Fuse No.	Capacity
Front wiper motor	IPDM E/R	39	30 A

Is the fuse blown?

- YES >> Refer to [WW-66, "Diagnosis Procedure"](#).
 NO >> GO TO 2

2. CHECK FRONT WIPER MOTOR (LO) OUTPUT VOLTAGE

Ⓟ WITH CONSULT ACTIVE TEST

1. Turn the ignition switch ON.
2. Select "FRONT WIPER" of IPDM E/R active test item.
3. While operating the test item, check voltage between IPDM E/R harness connector and ground.

Terminals		Test item	Voltage (Approx.)
(+)	(-)		
IPDM E/R		FRONT WIPER	Battery voltage
Connector	Terminal		
E121	32	LO	Battery voltage
		OFF	0V

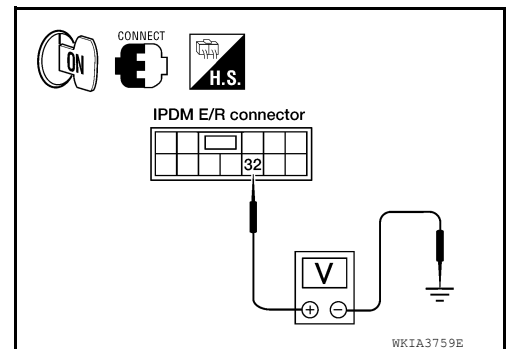

Is the measurement value normal?

- YES >> GO TO 3
 NO >> Replace IPDM E/R. Refer to [PCS-29, "Removal and Installation of IPDM E/R"](#).

3. CHECK FRONT WIPER MOTOR (LO) OPEN CIRCUIT

1. Turn the ignition switch OFF.

FRONT WIPER MOTOR LO CIRCUIT

< DTC/CIRCUIT DIAGNOSIS >

2. Disconnect IPDM E/R and front wiper motor.
3. Check continuity between IPDM E/R harness connector and front wiper motor harness connector.

IPDM E/R		Front wiper motor		Continuity
Connector	Terminal	Connector	Terminal	
E121	32	E23	1	Yes

Does continuity exist?

- YES >> Replace front wiper motor. Refer to [WW-70, "Removal and Installation"](#).
- NO >> Repair or replace harness.

A
B
C
D
E
F
G
H
I
J
K
M
N
O
P

WW

FRONT WIPER MOTOR HI CIRCUIT

< DTC/CIRCUIT DIAGNOSIS >

FRONT WIPER MOTOR HI CIRCUIT

Component Function Check

INFOID:000000007355275

1. CHECK FRONT WIPER HI OPERATION

⊗ IPDM E/R AUTO ACTIVE TEST

1. Start IPDM E/R auto active test. Refer to [PCS-9, "Diagnosis Description"](#).
2. Check that the front wiper operates at the HI operation.

Ⓟ WITH CONSULT ACTIVE TEST

1. Select "FRONT WIPER" of IPDM E/R active test item.
2. While operating the test item, check front wiper operation.

HI : Front wiper (HI) operation

OFF : Stop the front wiper.

Is front wiper (HI) operation normal?

- YES >> Front wiper motor HI circuit is normal.
 NO >> Refer to [WW-20, "Diagnosis Procedure"](#).

Diagnosis Procedure

INFOID:000000007355276

Regarding Wiring Diagram information, refer to [WW-50, "Wiring Diagram"](#).

1. CHECK FRONT WIPER MOTOR FUSE

1. Turn the ignition switch OFF.
2. Check that the following fuse is not blown.

Unit	Location	Fuse No.	Capacity
Front wiper motor	IPDM E/R	39	30 A

Is the fuse blown?

- YES >> Refer to [WW-66, "Diagnosis Procedure"](#).
 NO >> GO TO 2

2. CHECK FRONT WIPER MOTOR (HI) OUTPUT VOLTAGE

Ⓟ WITH CONSULT ACTIVE TEST

1. Turn the ignition switch ON.
2. Select "FRONT WIPER" of IPDM E/R active test item.
3. While operating the test item, check voltage between IPDM E/R harness connector and ground.

Terminals		Test item	Voltage (Approx.)
(+)	(-)		
IPDM E/R		FRONT WIPER	Battery voltage
Connector	Terminal		
E121	35	HI	Battery voltage
		OFF	0 V

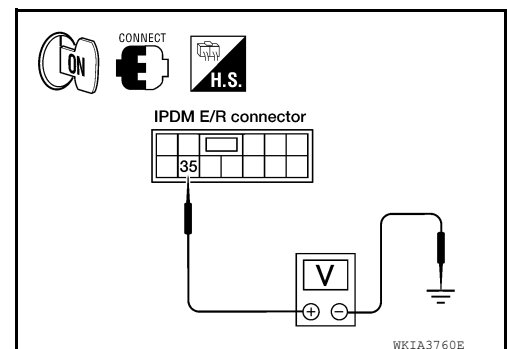

Is the measurement value normal?

- YES >> GO TO 3
 NO >> Replace IPDM E/R. Refer to [PCS-29, "Removal and Installation of IPDM E/R"](#).

3. CHECK FRONT WIPER MOTOR (HI) OPEN CIRCUIT

1. Turn the ignition switch OFF.

FRONT WIPER MOTOR HI CIRCUIT

< DTC/CIRCUIT DIAGNOSIS >

2. Disconnect IPDM E/R and front wiper motor.
3. Check continuity between IPDM E/R harness connector and front wiper motor harness connector.

IPDM E/R		Front wiper motor		Continuity
Connector	Terminal	Connector	Terminal	
E121	35	E23	4	Yes

Does continuity exist?

- YES >> Replace front wiper motor. Refer to [WW-70, "Removal and Installation"](#).
NO >> Repair or replace harness.

A
B
C
D
E
F
G
H
I
J
K
M
N
O
P

WW

FRONT WIPER AUTO STOP SIGNAL CIRCUIT

< DTC/CIRCUIT DIAGNOSIS >

FRONT WIPER AUTO STOP SIGNAL CIRCUIT

Component Function Check

INFOID:000000007355277

1. CHECK FRONT WIPER (AUTO STOP) SIGNAL

Ⓜ WITH CONSULT DATA MONITOR

1. Select "WIP AUTO STOP" of IPDM E/R data monitor item.
2. Operate the front wiper.
3. Check that "WIP AUTO STOP" changes to "STOP P" and "ACT P" linked with the wiper operation.

Monitor item	Condition		Monitor status
WIP AUTO STOP	Front wiper motor	Stop position	STOP P
		Except stop position	ACT P

Is the status of item normal?

- YES >> Front wiper auto stop signal circuit is normal.
 NO >> Refer to [WW-22, "Diagnosis Procedure"](#).

Diagnosis Procedure

INFOID:000000007355278

Regarding Wiring Diagram information, refer to [WW-50, "Wiring Diagram"](#).

1. CHECK IPDM E/R OUTPUT VOLTAGE

1. Turn the ignition switch OFF.
2. Disconnect front wiper motor.
3. Turn the ignition switch ON.
4. Check voltage between front wiper motor harness connector and ground.

Terminals		Voltage (V) (Approx.)
(+)	(-)	
Front wiper motor		Battery voltage
Connector	Terminal	
E23	5	

Is the measurement normal?

- YES >> Replace front wiper motor. Refer to [WW-70, "Removal and Installation"](#).
 NO >> GO TO 2

2. CHECK FRONT WIPER MOTOR (AUTO STOP) CIRCUIT CONTINUITY

1. Turn the ignition switch OFF.
2. Disconnect IPDM E/R connector E122.
3. Check continuity between IPDM E/R harness connector and front wiper motor harness connector.

IPDM E/R		Front wiper motor		Continuity
Connector	Terminal	Connector	Terminal	
E122	43	E23	5	Yes

4. Check continuity between IPDM E/R harness connector and ground.

IPDM E/R		Ground	Continuity
Connector	Terminal		
E122	43		No

Is the inspection result normal?

FRONT WIPER AUTO STOP SIGNAL CIRCUIT

< DTC/CIRCUIT DIAGNOSIS >

YES >> Replace IPDM E/R. Refer to [PCS-29. "Removal and Installation of IPDM E/R"](#).
NO >> Repair or replace harness.

A

B

C

D

E

F

G

H

I

J

K

WW

M

N

O

P

FRONT WIPER MOTOR GROUND CIRCUIT

< DTC/CIRCUIT DIAGNOSIS >

FRONT WIPER MOTOR GROUND CIRCUIT

Diagnosis Procedure

INFOID:000000007355279

Regarding Wiring Diagram information, refer to [WW-50. "Wiring Diagram"](#).

1. CHECK FRONT WIPER MOTOR (GROUND) OPEN CIRCUIT

1. Turn the ignition switch OFF.
2. Disconnect front wiper motor.
3. Check continuity between front wiper motor harness connector and ground.

Front wiper motor		Ground	Continuity
Connector	Terminal		
E23	2		Yes

Does continuity exist?

- YES >> Front wiper motor ground circuit is normal.
NO >> Repair or replace harness.

WASHER SWITCH

< DTC/CIRCUIT DIAGNOSIS >

WASHER SWITCH

Description

INFOID:000000007355280

- Washer switch is integrated with combination switch (wiper and washer switch).
- Combination switch (wiper and washer switch) switches polarity between front washer operating and rear washer operating to supply power and ground to the front and rear washer motor.

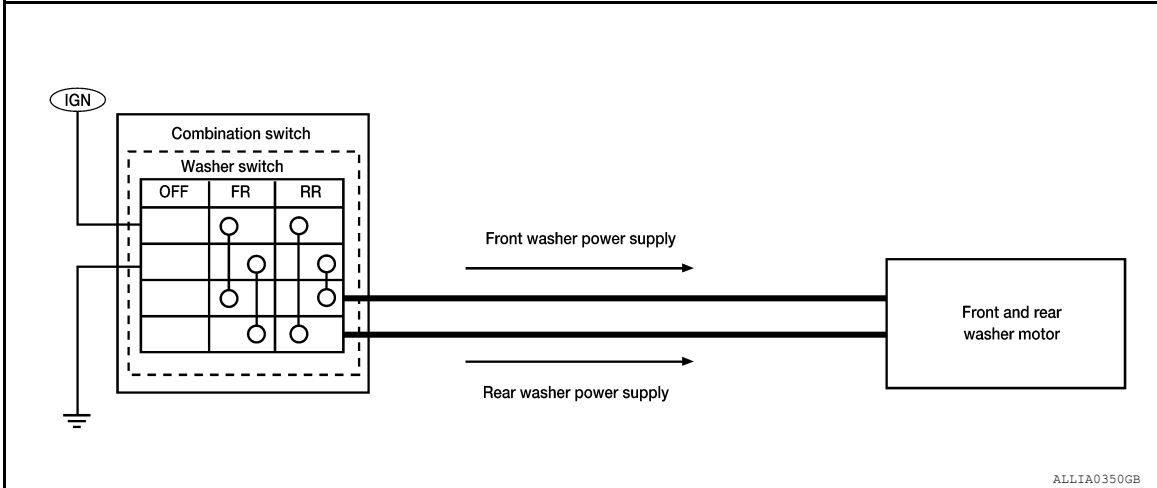

Component Inspection

INFOID:000000007355281

1. CHECK FRONT WASHER SWITCH

1. Turn the ignition switch OFF.
2. Disconnect combination switch (wiper and washer switch).
3. Check continuity between the combination switch (wiper and washer switch) terminals.

- A: Terminal 14
- B: Terminal 12
- C: Terminal 13
- D: Terminal 11

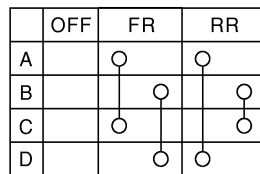

JPLIA0164GB

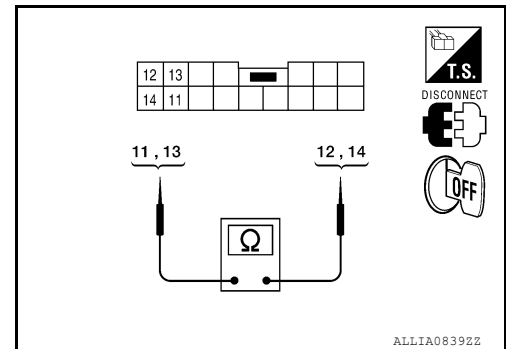

Combination switch (wiper and washer switch)		Condition	Continuity
Terminal			
11	12	Front washer switch ON	Yes
13	14		

Does continuity exist?

YES >> GO TO 2

NO >> Replace combination switch (wiper and washer switch). Refer to [WW-70. "Removal and Installation"](#).

2. CHECK REAR WASHER SWITCH

WASHER SWITCH

< DTC/CIRCUIT DIAGNOSIS >

Check continuity between the combination switch (wiper and washer switch) terminals.

A: Terminal 14

B: Terminal 12

C: Terminal 13

D: Terminal 11

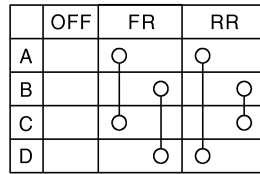

JPLIA0164GB

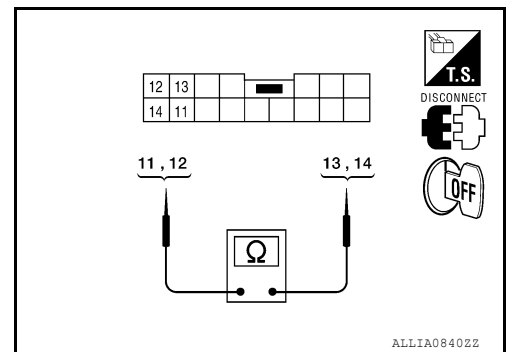

Combination switch (wiper and washer switch)		Condition	Continuity
Terminal			
11	14	Rear washer switch ON	Yes
12	13		

Does continuity exist?

YES >> Wiper and washer switch is normal.

NO >> Replace combination switch (wiper and washer switch). Refer to [WW-70. "Removal and Installation"](#).

WASHER MOTOR CIRCUIT

< DTC/CIRCUIT DIAGNOSIS >

WASHER MOTOR CIRCUIT

Diagnosis Procedure

INFOID:000000007355282

Regarding Wiring Diagram information, refer to [WW-50. "Wiring Diagram"](#), [WW-55. "Wiring Diagram"](#).

1. CHECK FRONT WASHER MOTOR FUSE

1. Turn the ignition switch OFF.
2. Check that the following fuse is not blown.

Unit	Location	Fuse No.	Capacity
Front washer motor	Fuse block (J/B)	15	10A

Is the fuse blown?

- YES >> Replace the fuse after repairing the affected circuit.
NO >> GO TO 2

2. CHECK WIPER AND WASHER SWITCH INPUT VOLTAGE

1. Disconnect combination switch (wiper and washer switch).
2. Turn the ignition switch ON.
3. Check voltage between combination switch (wiper and washer switch) harness connector and ground.

Terminals		Voltage (Approx.)
(+)	(-)	
Combination switch (wiper and washer switch)		Battery voltage
Connector	Terminal	
M28	14	

Is the measurement value normal?

- YES >> GO TO 3
NO >> Repair or replace harness.

3. CHECK WIPER AND WASHER SWITCH GROUND CIRCUIT

Check continuity between combination switch (wiper and washer switch) harness connector and ground.

Combination switch (wiper and washer switch)		Ground	Continuity
Connector	Terminal		
M28	12		Yes

Does continuity exist?

- YES >> GO TO 4
NO >> Repair or replace harness.

4. CHECK WIPER AND WASHER SWITCH

Check wiper and washer switch. Refer to [WW-25. "Component Inspection"](#).

Is the inspection result normal?

- YES >> GO TO 5
NO >> Replace wiper and washer switch. Refer to [WW-70. "Removal and Installation"](#).

5. CHECK FRONT AND REAR WASHER MOTOR POWER SUPPLY

1. Turn ignition switch OFF.
2. Connect combination switch (wiper and washer switch).
3. Disconnect front and rear washer motor.
4. Turn ignition switch ON.

WASHER MOTOR CIRCUIT

< DTC/CIRCUIT DIAGNOSIS >

5. Check voltage between front and rear washer motor harness connector and ground.

Terminal		(-)	Condition	Voltage (V) (Approx.)
(+)				
Front and rear washer motor	Terminal			
E105	1	2	Washer switch	Front: ON
	2	1		Rear: ON
				Battery voltage

Is the measurement value normal?

- YES >> Replace front and rear washer motor. Refer to [WW-70, "Removal and Installation"](#).
 NO >> Repair or replace harness.

REAR WIPER MOTOR CIRCUIT

< DTC/CIRCUIT DIAGNOSIS >

REAR WIPER MOTOR CIRCUIT

Component Function Check

INFOID:000000007355283

1. CHECK REAR WIPER ON OPERATION

Ⓜ WITH CONSULT ACTIVE TEST

1. Select "RR WIPER" of BCM(WIPER) active test item.
2. While operating the test item, check rear wiper operation.

ON : Rear wiper ON operation

OFF : Stop the rear wiper.

Is rear wiper operation normal?

- YES >> Rear wiper motor circuit is normal.
 NO >> Refer to [WW-29, "Diagnosis Procedure"](#).

Diagnosis Procedure

INFOID:000000007355284

Regarding Wiring Diagram information, refer to [WW-55, "Wiring Diagram"](#).

1. CHECK REAR WIPER MOTOR OUTPUT VOLTAGE

Ⓜ WITH CONSULT ACTIVE TEST

1. Turn the ignition switch OFF.
2. Disconnect rear wiper motor.
3. Turn the ignition switch ON.
4. Select "RR WIPER" of BCM(WIPER) active test item.
5. While operating the test item, check voltage between BCM harness connector and ground.

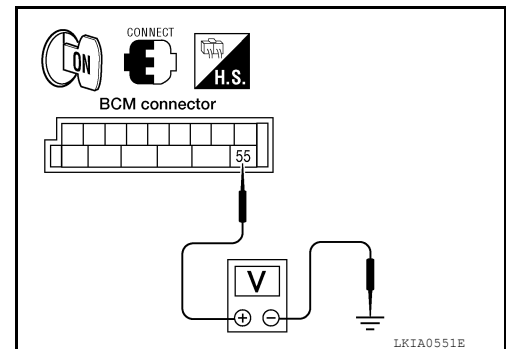

Terminals		Test item	Voltage (Approx.)
(+)	(-)		
BCM		REAR WIPER	Battery voltage
Connector	Terminal		
M19	55	ON	Battery voltage
		OFF	0V

Is the measurement value normal?

- YES >> GO TO 2
 NO >> GO TO 3

2. CHECK REAR WIPER MOTOR GROUND CIRCUIT

1. Turn the ignition switch OFF.
2. Check continuity between rear wiper motor harness connector and ground.

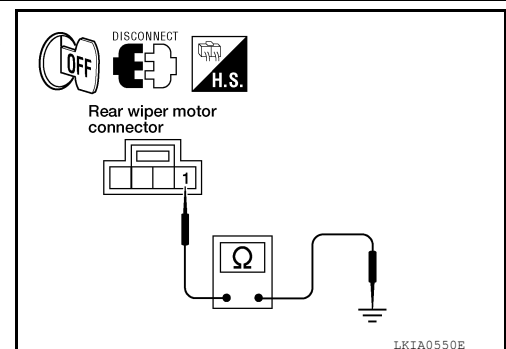

Rear wiper motor		Ground	Continuity
Connector	Terminal		
D602	1		Yes

Does continuity exist?

- YES >> Replace rear wiper motor. Refer to [WW-75, "Removal and Installation"](#).
 NO >> Repair or replace harness.

A
B
C
D
E
F
G
H
I
J
K
L
M
N
O
P

WW

REAR WIPER MOTOR CIRCUIT

< DTC/CIRCUIT DIAGNOSIS >

3. CHECK GLASS HATCH AJAR SWITCH CIRCUIT

1. Disconnect BCM.
2. Turn ignition switch OFF.
3. Make sure glass hatch is closed
4. Check continuity between BCM harness connector and ground.

BCM		Ground	Continuity
Connector	Terminal		
M19	42		No

Does continuity exist?

YES >> Repair harness if shorted. If not, refer to [SEC-48, "Diagnosis Procedure"](#) (with Intelligent Key system) or [SEC-144, "Diagnosis Procedure"](#) (without Intelligent Key system).

NO >> GO TO 4

4. CHECK REAR WIPER MOTOR OPEN CIRCUIT

1. Check continuity between BCM harness connector and rear wiper motor harness connector.

BCM		Rear wiper motor		Continuity
Connector	Terminal	Connector	Terminal	
M19	55	D602	4	Yes

Does continuity exist?

YES >> GO TO 5

NO >> Repair or replace harness.

5. CHECK REAR WIPER MOTOR SHORT CIRCUIT

Check continuity between BCM harness connector and ground.

BCM		Ground	Continuity
Connector	Terminal		
M19	55		No

Does continuity exist?

YES >> Repair or replace harness.

NO >> Replace BCM. Refer to [BCS-53, "Removal and Installation"](#).

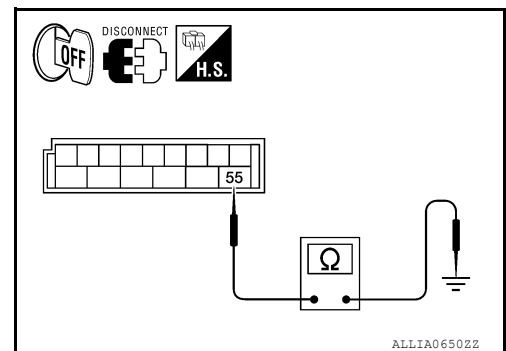
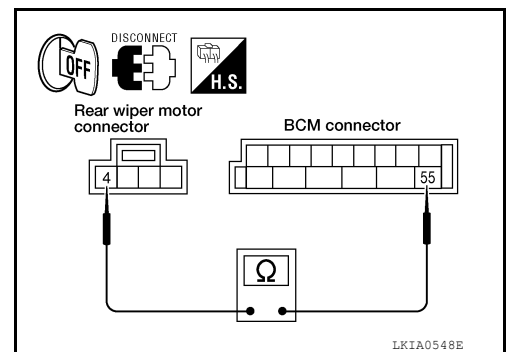
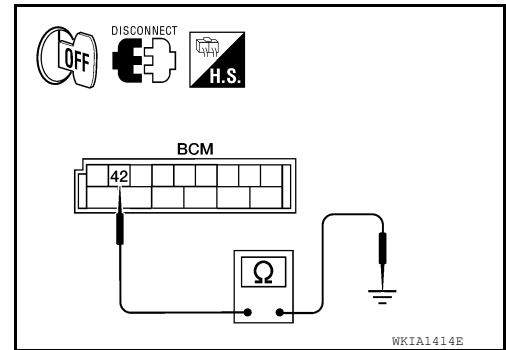

REAR WIPER AUTO STOP SIGNAL CIRCUIT

< DTC/CIRCUIT DIAGNOSIS >

REAR WIPER AUTO STOP SIGNAL CIRCUIT

Component Function Check

INFOID:000000007355285

1. CHECK REAR WIPER (AUTO STOP) OPERATION

Ⓜ WITH CONSULT DATA MONITOR

1. Select "WIPER" of BCM(WIPER) data monitor item.
2. Operate the rear wiper.
3. Check that "RR WIPER STOP" changes to "ON" and "OFF" linked with the wiper operation.

Monitor item	Condition	Monitor status
RR WIPER STOP	Stop position	ON
	Except stop position	OFF

Is the status of item normal?

- YES >> Rear wiper auto stop signal circuit is normal.
 NO >> Refer to [WW-31, "Diagnosis Procedure"](#).

Diagnosis Procedure

INFOID:000000007355286

Regarding Wiring Diagram information, refer to [WW-55, "Wiring Diagram"](#).

1. CHECK REAR WIPER MOTOR AUTO STOP CIRCUITS FOR OPEN

1. Turn ignition switch OFF.
2. Disconnect BCM and rear wiper motor.
3. Check continuity between BCM harness connector terminals and rear wiper motor harness connector terminals.

BCM		Rear wiper motor		Continuity
Connector	Terminal	Connector	Terminal	
M19	44	D602	2	Yes

Is inspection result normal?

- YES >> GO TO 2
 NO >> Repair or replace harness.

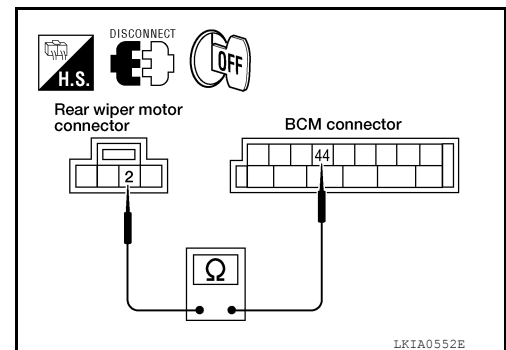

2. CHECK AUTO STOP CIRCUITS FOR SHORT TO GROUND

Check continuity between BCM harness connector terminals and ground.

BCM		Ground	Continuity
Connector	Terminal		
M19	44		No

Is inspection result normal?

- YES >> Replace BCM. Refer to [BCS-53, "Removal and Installation"](#).
 NO >> Repair or replace harness.

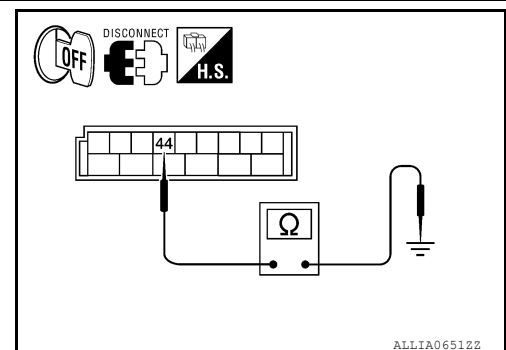

BCM (BODY CONTROL MODULE)

< ECU DIAGNOSIS INFORMATION >

ECU DIAGNOSIS INFORMATION

BCM (BODY CONTROL MODULE)

Reference Value

INFOID:000000007830027

NOTE:

The Signal Tech II Tool (J-50190) can be used to perform the following functions. Refer to the Signal Tech II User Guide for additional information.

- Activate and display TPMS transmitter IDs
- Display tire pressure reported by the TPMS transmitter
- Read TPMS DTCs
- Register TPMS transmitter IDs

VALUES ON THE DIAGNOSIS TOOL

Monitor Item	Condition	Value/Status
ACC ON SW	Ignition switch OFF or ON	Off
	Ignition switch ACC	On
AIR COND SW	A/C switch OFF	Off
	A/C switch ON	On
AIR PRESS FL	Front left tire air pressure value	kPa, kg/cm ² , psi
AIR PRESS FR	Front right tire air pressure value	kPa, kg/cm ² , psi
AIR PRESS RL	Rear left tire air pressure value	kPa, kg/cm ² , psi
AIR PRESS RR	Rear right tire air pressure value	kPa, kg/cm ² , psi
AUTO LIGHT SW	Lighting switch OFF	Off
	Lighting switch AUTO	On
BACK DOOR SW	Back door closed	Off
	Back door opened	On
BRAKE SW	Brake pedal released	Off
	Brake pedal applied	On
BUCKLE SW	Seat belt buckle unfastened	Off
	Seat belt buckle fastened	On
BUZZER	Buzzer in combination meter OFF	Off
	Buzzer in combination meter ON	On
CDL LOCK SW	Door lock/unlock switch does not operate	Off
	Press door lock/unlock switch to the LOCK side	On
CDL UNLOCK SW	Door lock/unlock switch does not operate	Off
	Press door lock/unlock switch to the UNLOCK side	On
DOOR SW-AS	Front door RH closed	Off
	Front door RH opened	On
DOOR SW-DR	Front door LH closed	Off
	Front door LH opened	On
DOOR SW-RL	Rear door LH closed	Off
	Rear door LH opened	On
DOOR SW-RR	Rear door RH closed	Off
	Rear door RH opened	On
FAN ON SIG	Blower motor fan switch OFF	Off
	Blower motor fan switch ON	On

BCM (BODY CONTROL MODULE)

< ECU DIAGNOSIS INFORMATION >

Monitor Item	Condition	Value/Status	
FR FOG SW	Front fog lamp switch OFF	Off	A
	Front fog lamp switch ON	On	
FR WASHER SW	Front washer switch OFF	Off	B
	Front washer switch ON	On	
FR WIPER LOW	Front wiper switch OFF	Off	C
	Front wiper switch LO	On	
FR WIPER HI	Front wiper switch OFF	Off	D
	Front wiper switch HI	On	
FR WIPER INT	Front wiper switch OFF	Off	E
	Front wiper switch INT	On	
FR WIPER STOP	Any position other than front wiper stop position	Off	
	Front wiper stop position	On	
HAZARD SW	When hazard switch is not pressed	Off	F
	When hazard switch is pressed	On	
HEAD LAMP SW 1	Headlamp switch OFF	Off	G
	Headlamp switch 1st	On	
HEAD LAMP SW 2	Headlamp switch OFF	Off	H
	Headlamp switch 1st	On	
HI BEAM SW	High beam switch OFF	Off	I
	High beam switch HI	On	
ID REGST FL1	ID registration of front left tire incomplete	YET	J
	ID registration of front left tire complete	DONE	
ID REGST FR1	ID registration of front right tire incomplete	YET	K
	ID registration of front right tire complete	DONE	
ID REGST RL1	ID registration of rear left tire incomplete	YET	
	ID registration of rear left tire complete	DONE	
ID REGST RR1	ID registration of rear right tire incomplete	YET	
	ID registration of rear right tire complete	DONE	
IGN ON SW	Ignition switch OFF or ACC	Off	WW
	Ignition switch ON	On	
IGN SW CAN	Ignition switch OFF or ACC	Off	M
	Ignition switch ON	On	
INT VOLUME	Wiper intermittent dial is in a dial position 1 - 7	1 - 7	N
I-KEY LOCK ¹	LOCK button of Intelligent Key is not pressed	Off	O
	LOCK button of Intelligent Key is pressed	On	
I-KEY PANIC ¹	PANIC button of Intelligent Key is not pressed	Off	P
	PANIC button of Intelligent Key is pressed	On	
I-KEY PW DWN ¹	UNLOCK button of Intelligent Key is not pressed	Off	
	UNLOCK button of Intelligent Key is pressed for greater than 3 seconds and driver's window operating in DOWN direction	On	
I-KEY UNLOCK ¹	UNLOCK button of Intelligent Key is not pressed	Off	
	UNLOCK button of Intelligent Key is pressed	On	
KEY CYL LK-SW	Door key cylinder LOCK position	Off	
	Door key cylinder other than LOCK position	On	

BCM (BODY CONTROL MODULE)

< ECU DIAGNOSIS INFORMATION >

Monitor Item	Condition	Value/Status
KEY CYL UN-SW	Door key cylinder UNLOCK position	Off
	Door key cylinder other than UNLOCK position	On
KEY ON SW	Mechanical key is removed from key cylinder	Off
	Mechanical key is inserted to key cylinder	On
KEYLESS LOCK ²	LOCK button of key fob is not pressed	Off
	LOCK button of key fob is pressed	On
KEYLESS PANIC ²	PANIC button of key fob is not pressed	Off
	PANIC button of key fob is pressed	On
KEYLESS UNLOCK ²	UNLOCK button of key fob is not pressed	Off
	UNLOCK button of key fob is pressed	On
LIGHT SW 1ST	Lighting switch OFF	Off
	Lighting switch 1st	On
OIL PRESS SW	<ul style="list-style-type: none"> • Ignition switch OFF or ACC • Engine running 	Off
	Ignition switch ON	On
OPTICAL SENSOR	Bright outside of the vehicle	Close to 5V
	Dark outside of the vehicle	Close to 0V
PASSING SW	Other than lighting switch PASS	Off
	Lighting switch PASS	On
PUSH SW ¹	Return to ignition switch to LOCK position	Off
	Press ignition switch	On
REAR DEF SW	Rear window defogger switch OFF	Off
	Rear window defogger switch ON	On
RR WASHER SW	Rear washer switch OFF	Off
	Rear washer switch ON	On
RR WIPER INT	Rear wiper switch OFF	Off
	Rear wiper switch INT	On
RR WIPER ON	Rear wiper switch OFF	Off
	Rear wiper switch ON	On
RR WIPER STOP	Rear wiper stop position	Off
	Other than rear wiper stop position	On
TURN SIGNAL L	Turn signal switch OFF	Off
	Turn signal switch LH	On
TURN SIGNAL R	Turn signal switch OFF	Off
	Turn signal switch RH	On
VEHICLE SPEED	While driving	Equivalent to speedometer reading
WARNING LAMP	Low tire pressure warning lamp in combination meter OFF	Off
	Low tire pressure warning lamp in combination meter ON	On

1: With Intelligent Key

2: With remote keyless entry system

BCM (BODY CONTROL MODULE)

< ECU DIAGNOSIS INFORMATION >

Terminal Layout

INFOID:000000007830028

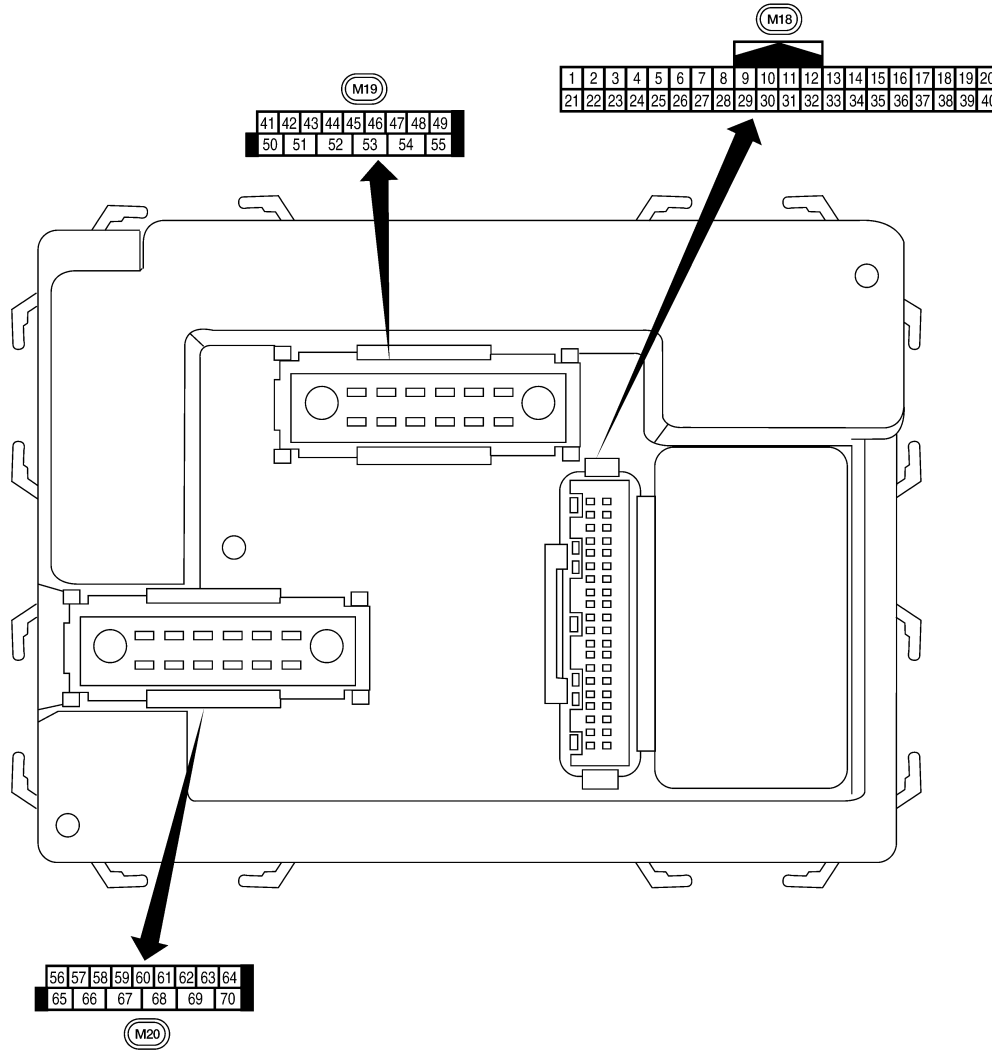

A
B
C
D
E
F
G
H
I
J
K
M
N
O
P

WW

Physical Values

LIIA2443E

INFOID:000000007830029

BCM (BODY CONTROL MODULE)

< ECU DIAGNOSIS INFORMATION >

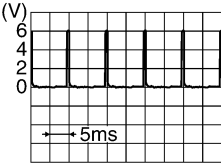
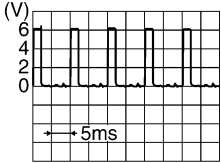
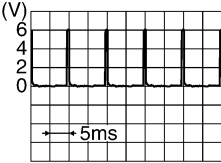
Terminal	Wire color	Signal name	Signal input/output	Measuring condition		Reference value or waveform (Approx.)
				Ignition switch	Operation or condition	
1	BR	Ignition keyhole illumination	Output	OFF	Door is locked (SW OFF)	Battery voltage
					Door is unlocked (SW ON)	0V
2	P	Combination switch input 5	Input	ON	Lighting, turn, wiper OFF Wiper dial position 4	 SKIA5291E
3	SB	Combination switch input 4	Input	ON	Lighting, turn, wiper OFF Wiper dial position 4	 SKIA5292E
4	V	Combination switch input 3	Input	ON	Lighting, turn, wiper OFF Wiper dial position 4	 SKIA5291E
5	L	Combination switch input 2	Input	ON	Lighting, turn, wiper OFF Wiper dial position 4	 SKIA5292E
6	R	Combination switch input 1				
9	Y	Rear window defogger switch	Input	ON	Rear window defogger switch ON	0V
					Rear window defogger switch OFF	5V
11	G/B	Ignition switch (ACC or ON)	Input	ACC or ON	Ignition switch ACC or ON	Battery voltage
12	LG	Front door switch RH	Input	OFF	ON (open)	0V
					OFF (closed)	Battery voltage
13	L	Rear door switch RH	Input	OFF	ON (open)	0V
					OFF (closed)	Battery voltage
15	W	Tire pressure warning check connector	Input	OFF	—	5V
18	BR	Remote keyless entry receiver and optical sensor (ground)	Output	OFF	—	0V

BCM (BODY CONTROL MODULE)

< ECU DIAGNOSIS INFORMATION >





Terminal	Wire color	Signal name	Signal input/output	Measuring condition		Reference value or waveform (Approx.)
				Ignition switch	Operation or condition	
19	V	Remote keyless entry receiver (power supply)	Output	OFF	Ignition switch OFF	<p style="text-align: right; font-size: small;">LIIA1893E</p>
20	G	Remote keyless entry receiver (signal)	Input	OFF	Stand-by (keyfob buttons released)	<p style="text-align: right; font-size: small;">LIIA1894E</p>
					When remote keyless entry receiver receives signal from keyfob (keyfob buttons pressed)	<p style="text-align: right; font-size: small;">LIIA1895E</p>
21	GR	NATS antenna amp.	Input	OFF → ON	Ignition switch (OFF → ON)	Just after turning ignition switch ON: Pointer of tester should move for approx. 1 second, then return to battery voltage.
22	V	BUS	—	—	Ignition switch ON or power window timer operates	<p style="text-align: right; font-size: small;">PIIA2344E</p>
23	G	Security indicator lamp	Output	OFF	Goes OFF → illuminates (Every 2.4 seconds)	Battery voltage → 0V
25	BR	NATS antenna amp.	Input	OFF → ON	Ignition switch (OFF → ON)	Just after turning ignition switch ON: Pointer of tester should move for approx. 1 second, then return to battery voltage.
27	W	Compressor ON signal	Input	ON	A/C switch OFF	5V
					A/C switch ON	0V
28	R	Front blower monitor	Input	ON	Front blower motor OFF	Battery voltage
					Front blower motor ON	0V
29	G	Hazard switch	Input	OFF	ON	0V
					OFF	5V
30 ¹	G	Back door opener switch	Input	OFF	ON (open)	0V
					OFF (closed)	Battery voltage
30 ²	SB	Back door opener switch	Input	OFF	ON (open)	0V
					OFF (closed)	Battery voltage

A
B
C
D
E
F
G
H
I
J
K
L
M
N
O
P

WW

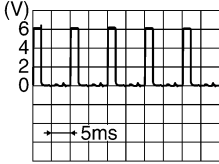
BCM (BODY CONTROL MODULE)

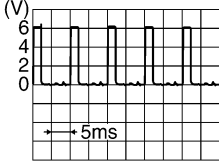
< ECU DIAGNOSIS INFORMATION >

Terminal	Wire color	Signal name	Signal input/output	Measuring condition		Reference value or waveform (Approx.)
				Ignition switch	Operation or condition	
32	O	Combination switch output 5	Output	ON	Lighting, turn, wiper OFF Wiper dial position 4	 <p style="text-align: right; font-size: small;">SKIA5291E</p>
33	GR	Combination switch output 4	Output	ON	Lighting, turn, wiper OFF Wiper dial position 4	 <p style="text-align: right; font-size: small;">SKIA5292E</p>
34	G	Combination switch output 3	Output	ON	Lighting, turn, wiper OFF Wiper dial position 4	 <p style="text-align: right; font-size: small;">SKIA5291E</p>
35	BR	Combination switch output 2	Output	ON	Lighting, turn, wiper OFF Wiper dial position 4	 <p style="text-align: right; font-size: small;">SKIA5292E</p>
36	LG	Combination switch output 1				
37 ¹	B	Key switch and key lock solenoid	Input	OFF	Key inserted	Battery voltage
					Key inserted	0V
37 ²	B	Key switch and ignition knob switch	Input	OFF	Intelligent Key inserted	Battery voltage
					Intelligent Key inserted	0V
38	W/R	Ignition switch (ON)	Input	ON	—	Battery voltage
39	L	CAN-H	—	—	—	—
40	P	CAN-L	—	—	—	—
42	LG	Glass hatch ajar switch	Input	ON	Glass hatch open	0V
					Glass hatch closed	Battery voltage
43	P	Back door latch switch	Input	OFF	ON (open)	0V
					OFF (closed)	Battery voltage

BCM (BODY CONTROL MODULE)

< ECU DIAGNOSIS INFORMATION >

Terminal	Wire color	Signal name	Signal input/output	Measuring condition		Reference value or waveform (Approx.)
				Ignition switch	Operation or condition	
44	O	Rear wiper auto stop switch	Input	ON	Rise up position (rear wiper arm on stopper)	0V
					A Position (full clockwise stop position)	Battery voltage
					Forward sweep (counterclockwise direction)	Fluctuating
					B Position (full counterclockwise stop position)	0V
					Reverse sweep (clockwise direction)	Fluctuating
47	GR	Front door switch LH	Input	OFF	ON (open)	0V
					OFF (closed)	Battery voltage
48	P	Rear door switch LH	Input	OFF	ON (open)	0V
					OFF (closed)	Battery voltage
49	L	Cargo lamp	Output	OFF	Any door open (ON)	0V
					All doors closed (OFF)	Battery voltage
51	O	Trailer turn signal (right)	Output	ON	Turn right ON	<p style="text-align: right; font-size: small;">SKIA3009J</p>
52	LG	Trailer turn signal (left)	Output	ON	Turn left ON	<p style="text-align: right; font-size: small;">SKIA3009J</p>
53	L	Back door latch actuator	Output	OFF	OFF	0
					ON	Battery voltage
55	W	Rear wiper output circuit 1	Output	ON	OFF	0
					ON	Battery voltage
56	R/Y	Battery saver output	Output	OFF	15 minutes (early production) or 10 minutes (late production) after ignition switch is turned OFF	0V
				ON	—	Battery voltage
57	R/Y	Battery power supply	Input	OFF	—	Battery voltage
58	W	Optical sensor	Input	ON	When optical sensor is illuminated	3.1V or more
					When optical sensor is not illuminated	0.6V or less
59	GR	Front door lock assembly LH actuator (unlock)	Output	OFF	OFF (neutral)	0V
					ON (unlock)	Battery voltage

A
B
C
D
E
F
G
H
I
J
K
M
N
O
P

WW

BCM (BODY CONTROL MODULE)

< ECU DIAGNOSIS INFORMATION >

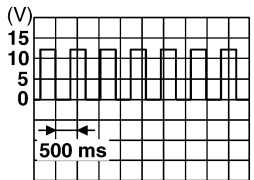
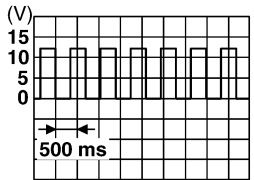
Terminal	Wire color	Signal name	Signal input/output	Measuring condition		Reference value or waveform (Approx.)	
				Ignition switch	Operation or condition		
60	LG	Turn signal (left)	Output	ON	Turn left ON	 <small>SKIA3009J</small>	
61	G	Turn signal (right)	Output	ON	Turn right ON	 <small>SKIA3009J</small>	
63	BR	Interior room/map lamp	Output	OFF	Any door switch	ON (open)	0V
					OFF (closed)	Battery voltage	
65	V	All door lock actuators (lock)	Output	OFF	OFF (neutral)	0V	
					ON (lock)	Battery voltage	
66	L	Front door lock actuator RH, rear door lock actuators LH/RH and glass hatch lock actuator (unlock)	Output	OFF	OFF (neutral)	0V	
					ON (unlock)	Battery voltage	
67	B	Ground	Input	ON	—	0V	
68	W/R	Power window power supply (RAP)	Output	—	Ignition switch ON	Battery voltage	
					Within 45 seconds after ignition switch OFF	Battery voltage	
					More than 45 seconds after ignition switch OFF	0V	
					When front door LH or RH is open or power window timer operates	0V	
69	L	Power window power supply	Output	—	—	Battery voltage	
70	W	Battery power supply	Input	OFF	—	Battery voltage	

1: With remote keyless entry system

2: With Intelligent Key system

Fail Safe

INFOID:000000007830030

Fail-safe index

BCM performs fail-safe control when any DTC listed below is detected.

Display contents of CONSULT	Fail-safe	Cancellation
U1000: CAN COMM CIRCUIT	Inhibit engine cranking	When the BCM re-establishes communication with the other modules.

DTC Inspection Priority Chart

INFOID:000000007830031

If some DTCs are displayed at the same time, perform inspections one by one based on the following priority chart.

BCM (BODY CONTROL MODULE)

< ECU DIAGNOSIS INFORMATION >

Priority	DTC	
1	• U1000: CAN COMM CIRCUIT	A
2	• B2190: NATS ANTENNA AMP • B2191: DIFFERENCE OF KEY • B2192: ID DISCORD BCM-ECM • B2193: CHAIN OF BCM-ECM • B2013: STRG COMM 1 • B2552: INTELLIGENT KEY • B2590: NATS MALFUNCTION	B C
3	• C1729: VHCL SPEED SIG ERR • C1735: IGNITION SIGNAL	D
4	• C1704: LOW PRESSURE FL • C1705: LOW PRESSURE FR • C1706: LOW PRESSURE RR • C1707: LOW PRESSURE RL • C1708: [NO DATA] FL • C1709: [NO DATA] FR • C1710: [NO DATA] RR • C1711: [NO DATA] RL • C1712: [CHECKSUM ERR] FL • C1713: [CHECKSUM ERR] FR • C1714: [CHECKSUM ERR] RR • C1715: [CHECKSUM ERR] RL • C1716: [PRESSDATA ERR] FL • C1717: [PRESSDATA ERR] FR • C1718: [PRESSDATA ERR] RR • C1719: [PRESSDATA ERR] RL • C1720: [CODE ERR] FL • C1721: [CODE ERR] FR • C1722: [CODE ERR] RR • C1723: [CODE ERR] RL • C1724: [BATT VOLT LOW] FL • C1725: [BATT VOLT LOW] FR • C1726: [BATT VOLT LOW] RR • C1727: [BATT VOLT LOW] RL	E F G H I J

DTC Index

INFOID:000000007830032

NOTE:

- Details of time display
- CRNT: Displays when there is a malfunction now or after returning to the normal condition until turning ignition switch OFF → ON again.
- 1 - 39: Displayed if any previous malfunction is present when current condition is normal. It increases like 1 → 2 → 3...38 → 39 after returning to the normal condition whenever ignition switch OFF → ON. The counter remains at 39 even if the number of cycles exceeds it. It is counted from 1 again when turning ignition switch OFF → ON after returning to the normal condition if the malfunction is detected again.

CONSULT display	Fail-safe	Intelligent Key warning lamp ON	Low tire pressure warning lamp ON	Reference page
No DTC is detected. Further testing may be required.	—	—	—	—
U1000: CAN COMM CIRCUIT	X	—	—	BCS-29
B2013: STRG COMM 1	—	—	—	SEC-30
B2190: NATS ANTENNA AMP	—	—	—	SEC-33 (with I-Key) SEC-132 (without I-Key)
B2191: DIFFERENCE OF KEY	—	—	—	SEC-36 (with I-Key) SEC-135 (without I-Key)

BCM (BODY CONTROL MODULE)

< ECU DIAGNOSIS INFORMATION >

CONSULT display	Fail-safe	Intelligent Key warning lamp ON	Low tire pressure warning lamp ON	Reference page
B2192: ID DISCORD BCM-ECM	—	—	—	SEC-37 (with I-Key) SEC-136 (without I-Key)
B2193: CHAIN OF BCM-ECM	—	—	—	SEC-39 (with I-Key) SEC-138 (without I-Key)
B2552: INTELLIGENT KEY	—	—	—	SEC-41
B2590: NATS MALFUNCTION	—	—	—	SEC-42
C1708: [NO DATA] FL	—	—	X	WT-14
C1709: [NO DATA] FR	—	—	X	WT-14
C1710: [NO DATA] RR	—	—	X	WT-14
C1711: [NO DATA] RL	—	—	X	WT-14
C1712: [CHECKSUM ERR] FL	—	—	X	WT-16
C1713: [CHECKSUM ERR] FR	—	—	X	WT-16
C1714: [CHECKSUM ERR] RR	—	—	X	WT-16
C1715: [CHECKSUM ERR] RL	—	—	X	WT-16
C1716: [PRESSDATA ERR] FL	—	—	X	WT-18
C1717: [PRESSDATA ERR] FR	—	—	X	WT-18
C1718: [PRESSDATA ERR] RR	—	—	X	WT-18
C1719: [PRESSDATA ERR] RL	—	—	X	WT-18
C1720: [CODE ERR] FL	—	—	X	WT-16
C1721: [CODE ERR] FR	—	—	X	WT-16
C1722: [CODE ERR] RR	—	—	X	WT-16
C1723: [CODE ERR] RL	—	—	X	WT-16
C1724: [BATT VOLT LOW] FL	—	—	X	WT-16
C1725: [BATT VOLT LOW] FR	—	—	X	WT-16
C1726: [BATT VOLT LOW] RR	—	—	X	WT-16
C1727: [BATT VOLT LOW] RL	—	—	X	WT-16
C1729: VHCL SPEED SIG ERR	—	—	X	WT-20
C1735: IGNITION SWITCH	—	—	X	WT-21

IPDM E/R (INTELLIGENT POWER DISTRIBUTION MODULE ENGINE ROOM)

< ECU DIAGNOSIS INFORMATION >

IPDM E/R (INTELLIGENT POWER DISTRIBUTION MODULE ENGINE ROOM)

Reference Value

INFOID:000000007830035

VALUES ON THE DIAGNOSIS TOOL

Monitor Item	Condition		Value/Status
MOTOR FAN REQ	Engine idle speed	Changes depending on engine coolant temperature, air conditioner operation status, vehicle speed, etc.	1, 2, 3, 4
AC COMP REQ	A/C switch OFF		Off
	A/C switch ON		On
TAIL&CLR REQ	Lighting switch OFF		Off
	Lighting switch 1ST, 2ND, HI or AUTO (Light is illuminated)		On
HL LO REQ	Lighting switch OFF		Off
	Lighting switch 2ND HI or AUTO (Light is illuminated)		On
HL HI REQ	Lighting switch OFF		Off
	Lighting switch HI		On
FR FOG REQ	Lighting switch 2ND or AUTO (Light is illuminated)	Front fog lamp switch OFF	Off
		<ul style="list-style-type: none"> Front fog lamp switch ON Daytime light activated (Canada only) 	On
FR WIP REQ	Ignition switch ON	Front wiper switch OFF	Stop
		Front wiper switch INT	1LOW
		Front wiper switch LO	Low
		Front wiper switch HI	Hi
WIP AUTO STOP	Ignition switch ON	Front wiper stop position	STOP P
		Any position other than front wiper stop position	ACT P
WIP PROT	Ignition switch ON	Front wiper operates normally	Off
		Front wiper stops at fail-safe operation	BLOCK
ST RLY REQ	Ignition switch OFF or ACC		Off
	Ignition switch START		On
IGN RLY	Ignition switch OFF or ACC		Off
	Ignition switch ON		On
RR DEF REQ	Rear defogger switch OFF		Off
	Rear defogger switch ON		On
OIL P SW	Ignition switch OFF, ACC or engine running		Open
	Ignition switch ON		Close
DTRL REQ	Daytime light system requested OFF with CONSULT.		Off
	Daytime light system requested ON with CONSULT.		On
THFT HRN REQ	Not operated		Off
	<ul style="list-style-type: none"> Panic alarm is activated Horn is activated with VEHICLE SECURITY (THEFT WARNING) SYSTEM 		On

IPDM E/R (INTELLIGENT POWER DISTRIBUTION MODULE ENGINE ROOM)

< ECU DIAGNOSIS INFORMATION >

Monitor Item	Condition	Value/Status
HORN CHIRP	Not operated	Off
	Door locking with keyfob or Intelligent Key (if equipped) (horn chirp mode)	On

Terminal Layout

INFOID:000000007830036

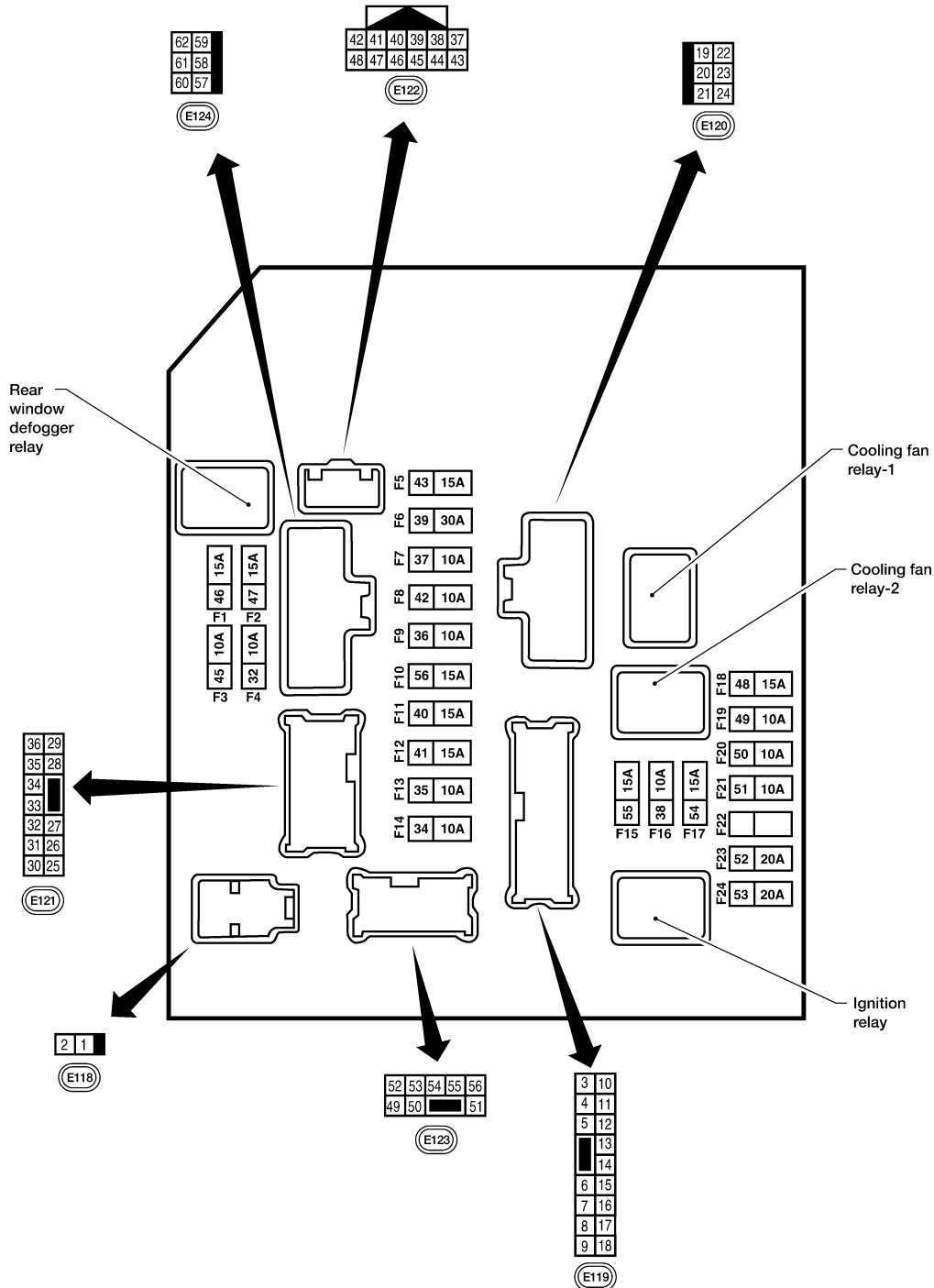

NOTE:

Numbers preceded by an "F" represent the fuse numbers imprinted on the IPDM E/R. The other numbers represent the fuse numbers as they appear in the wiring diagrams.

AAMIA0386GB

IPDM E/R (INTELLIGENT POWER DISTRIBUTION MODULE ENGINE ROOM)

< ECU DIAGNOSIS INFORMATION >

Physical Values

INFOID:000000007830037

PHYSICAL VALUES

Terminal	Wire color	Signal name	Signal input/output	Measuring condition		Reference value (Approx.)
				Ignition switch	Operation or condition	
1	W	Battery power supply	Input	OFF	—	Battery voltage
2	R	Battery power supply	Input	OFF	—	Battery voltage
3	G	ECM relay	Output	—	Ignition switch ON or START	Battery voltage
					Ignition switch OFF or ACC	0V
4	P	ECM relay	Output	—	Ignition switch ON or START	Battery voltage
					Ignition switch OFF or ACC	0V
6	V	Throttle control motor relay	Output	—	Ignition switch ON or START	Battery voltage
					Ignition switch OFF or ACC	0V
7	BR	ECM relay control	Input	—	Ignition switch ON or START	0V
					Ignition switch OFF or ACC	Battery voltage
8	W/R	Fuse 54	Output	—	Ignition switch ON or START	Battery voltage
					Ignition switch OFF or ACC	0V
10	R/B	Fuse 45	Output	ON	Daytime light system active	0V
					Daytime light system inactive	Battery voltage
11	Y	A/C compressor	Output	ON or START	A/C switch ON or defrost A/C switch	Battery voltage
					A/C switch OFF or defrost A/C switch	0V
12	W/G	Ignition switch supplied power	Input	—	OFF or ACC	0V
					ON or START	Battery voltage
13	R	Fuel pump relay	Output	—	Ignition switch ON or START	Battery voltage
					Ignition switch OFF or ACC	0V
14	W/G	Fuse 49	Output	—	Ignition switch ON or START	Battery voltage
					Ignition switch OFF or ACC	0V
15	W/R	Fuse 50 (ABS)	Output	—	Ignition switch ON or START	Battery voltage
					Ignition switch OFF or ACC	0V
16	W/G	Fuse 51	Output	—	Ignition switch ON or START	Battery voltage
					Ignition switch OFF or ACC	0V
17	W/G	Fuse 55	Output	—	Ignition switch ON or START	Battery voltage
					Ignition switch OFF or ACC	0V
19	W	Starter motor	Output	START	—	Battery voltage
20	BR	Cooling fan motor (low)	Output	ON or START	—	Battery voltage
21	GR	Ignition switch supplied power	Input	—	OFF or ACC	0V
					START	Battery voltage
22	G	Battery power supply	Output	OFF	—	Battery voltage
23	LG	Door mirror defogger output signal	Output	—	When rear defogger switch is ON	Battery voltage
					When raker defogger switch is OFF	0V

IPDM E/R (INTELLIGENT POWER DISTRIBUTION MODULE ENGINE ROOM)

< ECU DIAGNOSIS INFORMATION >

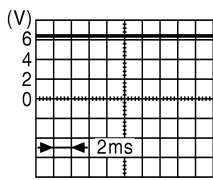
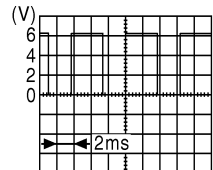
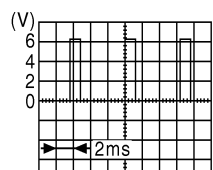
Terminal	Wire color	Signal name	Signal input/output	Measuring condition		Reference value (Approx.)
				Ignition switch	Operation or condition	
24	P	Cooling fan motor (high)	Output	—	Conditions correct for cooling fan operation	Battery voltage
					Conditions not correct for cooling fan operation	0V
27	W	Fuse 38	Output	—	Ignition switch ON or START	Battery voltage
					Ignition switch OFF or ACC	0V
28	R	LH front parking and front side marker lamp	Output	OFF	Lighting switch 1st position OFF	0V
					Lighting switch 1st position ON	Battery voltage
29	G	Trailer tow relay	Output	ON	Lighting switch 1st position OFF	0V
					Lighting switch 1st position ON	Battery voltage
30	R/B	Fuse 53	Output	—	Ignition switch ON or START	Battery voltage
					Ignition switch OFF or ACC	0V
32	GR	Wiper low speed signal	Output	ON or START	Wiper switch OFF	Battery voltage
					Wiper switch LO or INT	0V
35	L	Wiper high speed signal	Output	ON or START	Wiper switch OFF, LO, INT	Battery voltage
					Wiper switch HI	0V
37	Y	Power generation command signal	Output	—	Ignition switch ON	 <p style="text-align: right;">JPMIA0001GB</p> <p style="text-align: center;">6.3 V</p>
					40% is set on "Active test," "ALTERNATOR DUTY" of "ENGINE"	 <p style="text-align: right;">JPMIA0002GB</p> <p style="text-align: center;">3.8 V</p>
					40% is set on "Active test," "ALTERNATOR DUTY" of "ENGINE"	 <p style="text-align: right;">JPMIA0003GB</p> <p style="text-align: center;">1.4 V</p>
38	B	Ground	Input	—	—	0V
39	L	CAN-H	—	ON	—	—
40	P	CAN-L	—	ON	—	—
42	GR	Oil pressure switch	Input	—	Engine running	Battery voltage
					Engine stopped	0V

IPDM E/R (INTELLIGENT POWER DISTRIBUTION MODULE ENGINE ROOM)

< ECU DIAGNOSIS INFORMATION >

Terminal	Wire color	Signal name	Signal input/output	Measuring condition		Reference value (Approx.)
				Ignition switch	Operation or condition	
43	G	Wiper auto stop signal	Input	ON or START	Wiper switch OFF, LO, INT	Battery voltage
44	R	Daytime light relay control	Input	ON	Daytime light system active	0V
					Daytime light system inactive	Battery voltage
45	LG	Horn relay control	Input	ON	When door locks are operated using keyfob or Intelligent Key (if equipped) (OFF → ON)*	Battery voltage → 0V
46	V	Fuel pump relay control	Input	—	Ignition switch ON or START	0V
					Ignition switch OFF or ACC	Battery voltage
47	O	Throttle control motor relay control	Input	—	Ignition switch ON or START	0V
					Ignition switch OFF or ACC	Battery voltage
48	R	Starter relay (range switch)	Input	ON or START	Selector lever in "P" or "N"	0V
					Selector lever any other position	Battery voltage
49	GR	Front RH parking and front side marker lamp	Output	OFF	Lighting switch 1st position OFF	0V
					ON	Battery voltage
50	W	Front fog lamp (LH)	Output	ON or START	Lighting switch must be in the 2nd position (LOW beam is ON) and the front fog lamp switch OFF	0V
					ON	Battery voltage
51	V	Front fog lamp (RH)	Output	ON or START	Lighting switch must be in the 2nd position (LOW beam is ON) and the front fog lamp switch OFF	0V
					ON	Battery voltage
52	P	LH low beam headlamp	Output	—	Lighting switch in 2nd position	Battery voltage
54	R	RH low beam headlamp	Output	—	Lighting switch in 2nd position	Battery voltage
55	G	LH high beam headlamp	Output	—	Lighting switch in 2nd position and placed in HIGH or PASS position	Battery voltage
56	L	RH high beam headlamp	Output	—	Lighting switch in 2nd position and placed in HIGH or PASS position	Battery voltage
57	GR	Parking, license, and tail lamp	Output	ON	Lighting switch 1st position OFF	0V
					ON	Battery voltage
59	B	Ground	Input	—	—	0V
60	GR	Rear window defogger relay	Output	ON or START	Rear defogger switch ON	Battery voltage
					Rear defogger switch OFF	0V
61	R/B	Fuse 32	Output	OFF	—	Battery voltage

A
B
C
D
E
F
G
H
I
J
K
WW
M
N
O
P

IPDM E/R (INTELLIGENT POWER DISTRIBUTION MODULE ENGINE ROOM)

< ECU DIAGNOSIS INFORMATION >

*: When horn reminder is ON

Fail Safe

INFOID:000000007830038

CAN COMMUNICATION CONTROL

When CAN communication with ECM and BCM is impossible, IPDM E/R performs fail-safe control. After CAN communication recovers normally, it also returns to normal control.

If No CAN Communication Is Available With ECM

Control part	Fail-safe in operation
Cooling fan	<ul style="list-style-type: none"> • Turns ON the cooling fan relay when the ignition switch is turned ON • Turns OFF the cooling fan relay when the ignition switch is turned OFF

If No CAN Communication Is Available With BCM

Control part	Fail-safe in operation
Headlamp	<ul style="list-style-type: none"> • Turns ON the headlamp low relay when the ignition switch is turned ON • Turns OFF the headlamp low relay when the ignition switch is turned OFF • Headlamp high relay OFF
<ul style="list-style-type: none"> • Parking lamps • License plate lamps • Tail lamps 	<ul style="list-style-type: none"> • Turns ON the tail lamp relay when the ignition switch is turned ON • Turns OFF the tail lamp relay when the ignition switch is turned OFF
Front wiper	<ul style="list-style-type: none"> • The status just before activation of fail-safe control is maintained until the ignition switch is turned OFF while the front wiper is operating at LO or HI speed. • The wiper is operated at LO speed until the ignition switch is turned OFF if the fail-safe control is activated while the front wiper is set in the INT mode and the front wiper motor is operating.
Rear window defogger	Rear window defogger relay OFF
A/C compressor	A/C relay OFF
Front fog lamps (if equipped)	Front fog lamp relay OFF

IGNITION RELAY MALFUNCTION DETECTION FUNCTION

- IPDM E/R monitors the voltage at the contact circuit and excitation coil circuit of the ignition relay inside it.
- IPDM E/R judges the ignition relay error if the voltage differs between the contact circuit and the excitation coil circuit.
- If the ignition relay cannot turn OFF due to contact seizure, it activates the tail lamp relay for 10 minutes to alert the user to the ignition relay malfunction when the ignition switch is turned OFF.

Ignition switch	Ignition relay	Tail lamp relay
ON	ON	—
OFF	OFF	—

NOTE:

The tail lamp turns OFF when the ignition switch is turned ON.

FRONT WIPER CONTROL

IPDM E/R detects front wiper stop position by a front wiper auto stop signal.

When a front wiper auto stop signal is in the conditions listed below, IPDM E/R stops power supply to wiper after repeating a front wiper 10 second activation and 20 second stop five times.

Ignition switch	Front wiper switch	Auto stop signal
ON	OFF	Front wiper stop position signal cannot be input 10 seconds.
	ON	The signal does not change for 10 seconds.

NOTE:

This operation status can be confirmed on the IPDM E/R "DATA MONITOR" that displays "Block" for the item "WIP PROT" while the wiper is stopped.

IPDM E/R (INTELLIGENT POWER DISTRIBUTION MODULE ENGINE ROOM)

< ECU DIAGNOSIS INFORMATION >

STARTER MOTOR PROTECTION FUNCTION

IPDM E/R turns OFF the starter control relay to protect the starter motor when the starter control relay remains active for 90 seconds.

DTC Index

INFOID:000000007830039

CONSULT display	Fail-safe	TIME ^{NOTE}		Refer to
No DTC is detected. further testing may be required.	—	—	—	—
U1000: CAN COMM CIRCUIT	×	CRNT	1 – 39	PCS-13

NOTE:

The details of TIME display are as follows.

- CRNT: The malfunctions that are detected now
- 1 - 39: The number is indicated when it is normal at present and a malfunction was detected in the past. It increases like 0 → 1 → 2 ... 38 → 39 after returning to the normal condition whenever IGN OFF → ON. It is fixed to 39 until the self-diagnosis results are erased if it is over 39. It returns to 0 when a malfunction is detected again in the process.

A
B
C
D
E
F
G
H
I
J
K
M
N
O
P

WW

FRONT WIPER AND WASHER SYSTEM

< WIRING DIAGRAM >

WIRING DIAGRAM

FRONT WIPER AND WASHER SYSTEM

Wiring Diagram

INFOID:000000007355298

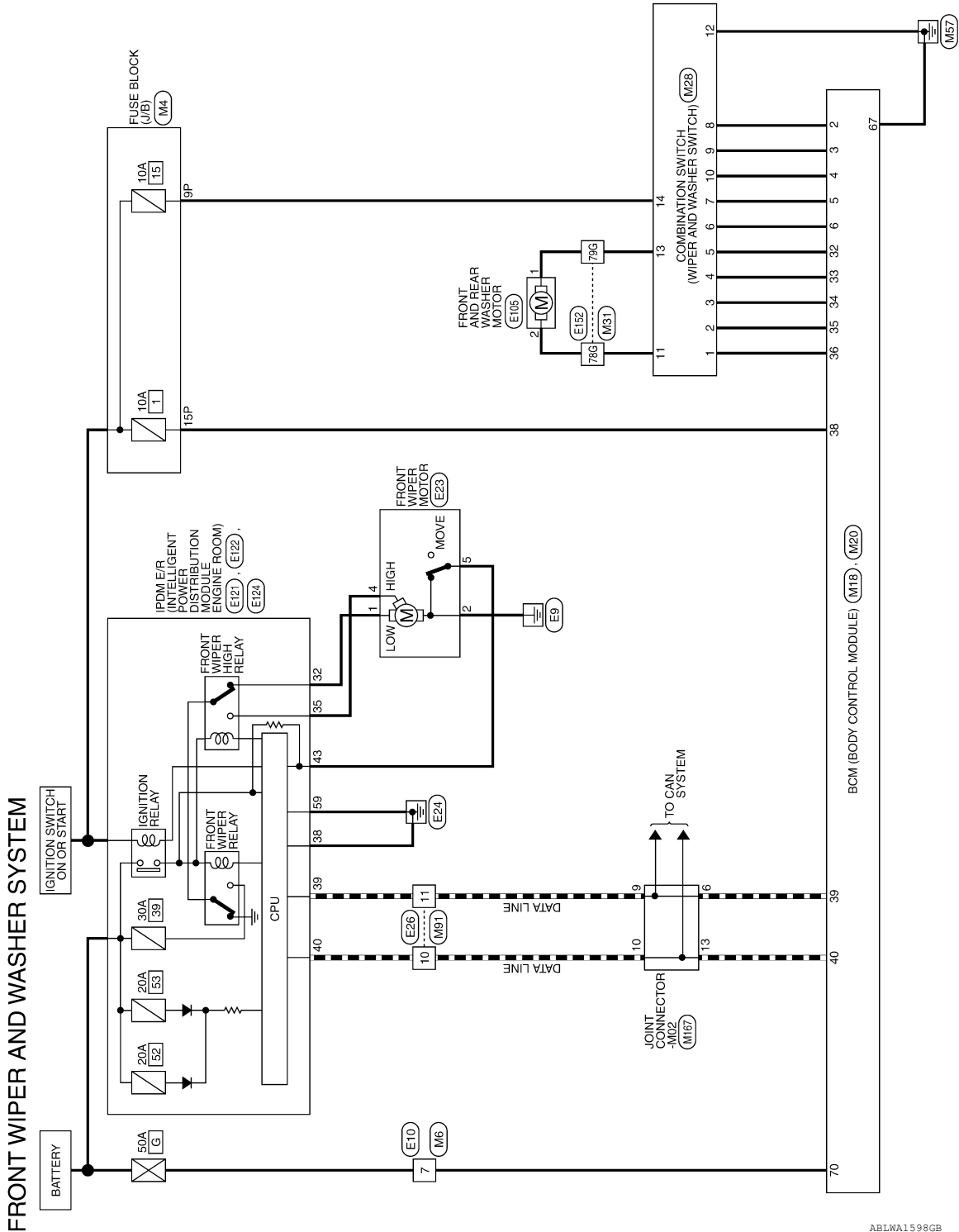

ABLWA1598GB

FRONT WIPER AND WASHER SYSTEM

< WIRING DIAGRAM >

FRONT WIPER AND WASHER SYSTEM CONNECTORS

Connector No.	M4
Connector Name	FUSE BLOCK (J/B)
Connector Color	WHITE



Terminal No.	Color of Wire	Signal Name
9P	W/G	-
15P	W/R	-

Connector No.	M6
Connector Name	WIRE TO WIRE
Connector Color	WHITE

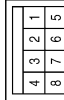

Terminal No.	Color of Wire	Signal Name
7	W	-

Connector No.	M18
Connector Name	BCM (BODY CONTROL MODULE)
Connector Color	WHITE

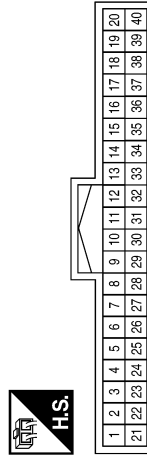

Terminal No.	Color of Wire	Signal Name
2	P	INPUT 5
3	SB	INPUT 4

Terminal No.	Color of Wire	Signal Name
4	V	INPUT 3
5	L	INPUT 2
6	R	INPUT 1
32	O	OUTPUT 5
33	GR	OUTPUT 4
34	G	OUTPUT 3
35	BR	OUTPUT 2
36	LG	OUTPUT 1
38	W/R	IGN SW
39	L	CAN-H
40	P	CAN-L

Connector No.	M20
Connector Name	BCM (BODY CONTROL MODULE)
Connector Color	BLACK

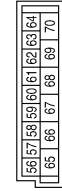

Terminal No.	Color of Wire	Signal Name
67	B	GND (POWER)
70	W	BAT (F/L)

ABLIA0384GB

A
B
C
D
E
F
G
H
I
J
K
L
M
N
O
P

WW

FRONT WIPER AND WASHER SYSTEM

< WIRING DIAGRAM >

Terminal No.	Color of Wire	Signal Name
4	GR	INPUT 4
5	O	INPUT 5
6	R	OUTPUT 1
7	L	OUTPUT 2
8	P	OUTPUT 5
9	SB	OUTPUT 4
10	V	OUTPUT 3
11	O	WASHER MOTOR (RR+)
12	B	GND
13	L	WASHER MOTOR (RR-)
14	W/G	IGN

Connector No.	M28
Connector Name	COMBINATION SWITCH
Connector Color	WHITE

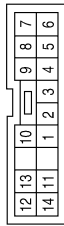

Terminal No.	Color of Wire	Signal Name
1	LG	INPUT 1
2	BR	INPUT 2
3	G	INPUT 3

Terminal No.	Color of Wire	Signal Name
78G	O	-
79G	L	-

Connector No.	M31
Connector Name	WIRE TO WIRE
Connector Color	WHITE

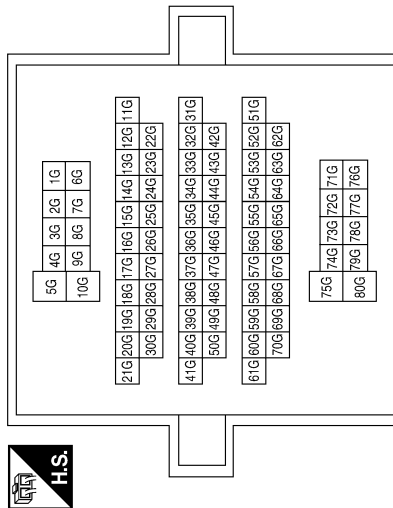

Connector No.	M91
Connector Name	WIRE TO WIRE
Connector Color	WHITE

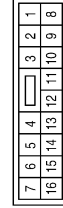

Terminal No.	Color of Wire	Signal Name
10	P	-
11	L	-

ABLIA0385GB

FRONT WIPER AND WASHER SYSTEM

< WIRING DIAGRAM >

Connector No.	E23
Connector Name	FRONT WIPER MOTOR
Connector Color	GRAY

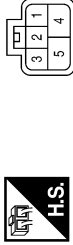

Terminal No.	Color of Wire	Signal Name
1	GR	-
2	B	-
4	L	-
5	G	-

Connector No.	E10
Connector Name	WIRE TO WIRE
Connector Color	WHITE



Terminal No.	Color of Wire	Signal Name
7	W	-

Connector No.	M167
Connector Name	JOINT CONNECTOR-M02
Connector Color	BLUE

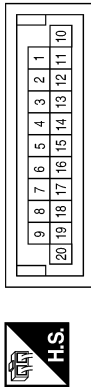

Terminal No.	Color of Wire	Signal Name
6	L	-
9	L	-
10	P	-
13	P	-

Connector No.	E121
Connector Name	IPDM E/R (INTELLIGENT POWER DISTRIBUTION MODULE ENGINE ROOM)
Connector Color	BROWN

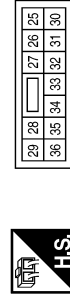

Terminal No.	Color of Wire	Signal Name
32	GR	FR WIPER LO
35	L	FR WIPER HI

Connector No.	E105
Connector Name	FRONT AND REAR WASHER MOTOR
Connector Color	BLACK



Terminal No.	Color of Wire	Signal Name
1	L	-
2	O	-

Connector No.	E26
Connector Name	WIRE TO WIRE
Connector Color	WHITE

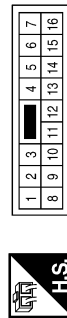

Terminal No.	Color of Wire	Signal Name
10	P	-
11	L	-

ABLIA3335GB

A
B
C
D
E
F
G
H
I
J
K
L
M
N
O
P

WW

FRONT WIPER AND WASHER SYSTEM

< WIRING DIAGRAM >

Connector No.	E152
Connector Name	WIRE TO WIRE
Connector Color	WHITE

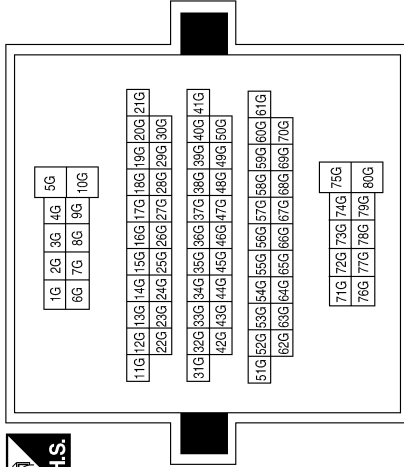

Terminal No.	Color of Wire	Signal Name
78G	O	-
79G	L	-

Connector No.	E124
Connector Name	IPDM E/R (INTELLIGENT POWER DISTRIBUTION MODULE ENGINE ROOM)
Connector Color	BLACK



Terminal No.	Color of Wire	Signal Name
59	B	GND (POWER)

Connector No.	E122
Connector Name	IPDM E/R (INTELLIGENT POWER DISTRIBUTION MODULE ENGINE ROOM)
Connector Color	WHITE

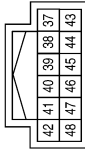

Terminal No.	Color of Wire	Signal Name
38	B	GND (SIGNAL)
39	L	CAN-H
40	P	CAN-L
43	G	AUTO STOP SW

ABLIA3336GB

REAR WIPER AND WASHER SYSTEM

< WIRING DIAGRAM >

REAR WIPER AND WASHER SYSTEM

Wiring Diagram

INFOID:000000007355299

REAR WIPER AND WASHER SYSTEM

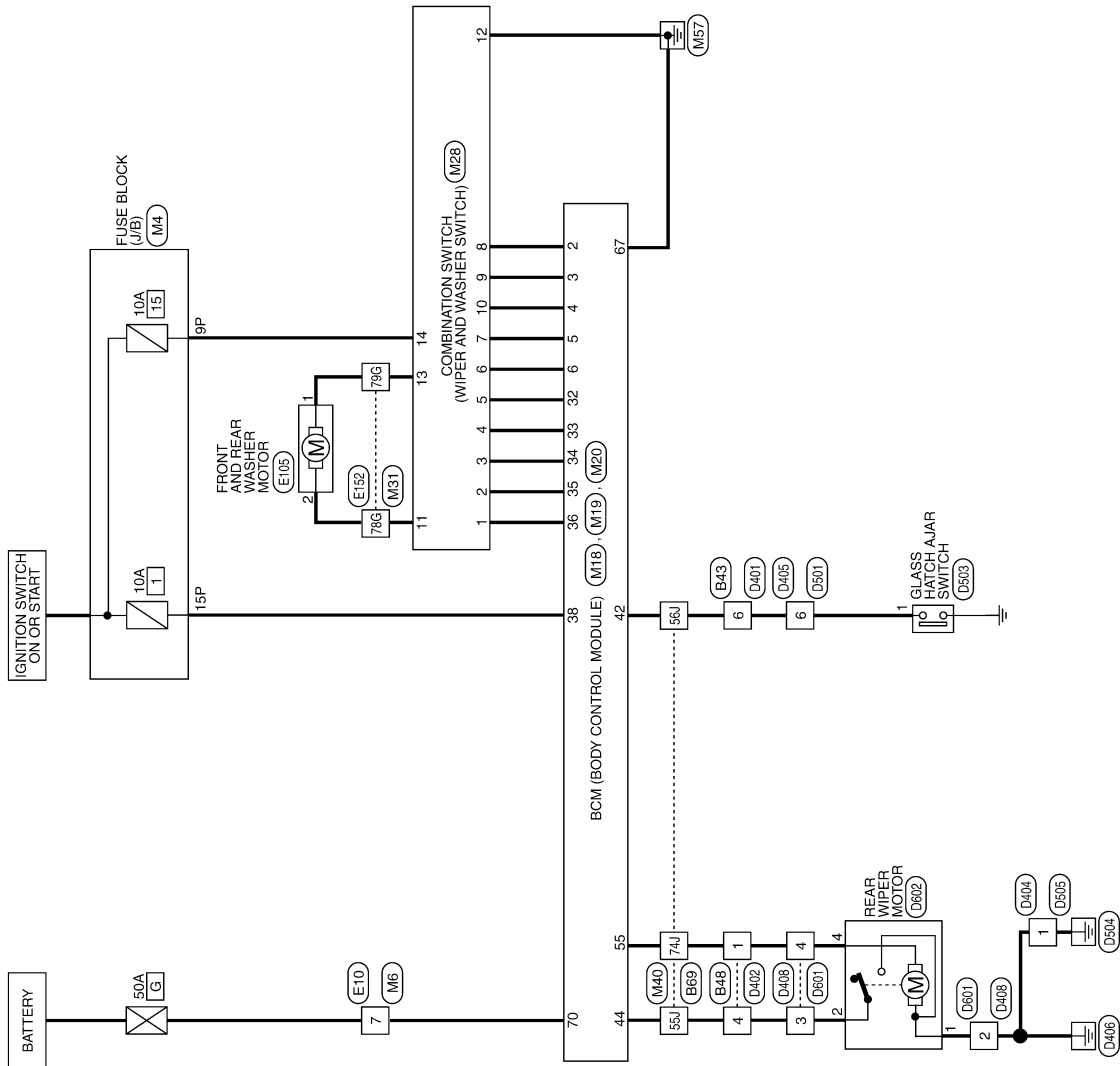

ABLWA1599GB

A
B
C
D
E
F
G
H
I
J
K
L
M
N
O
P

WW

REAR WIPER AND WASHER SYSTEM

< WIRING DIAGRAM >

REAR WIPER AND WASHER SYSTEM CONNECTORS

Connector No.	M4
Connector Name	FUSE BLOCK (J/B)
Connector Color	WHITE



7P	8P	5P	4P	3P	2P	1P		
16P	15P	14P	13P	12P	11P	10P	9P	8P

Terminal No.	Color of Wire	Signal Name
9P	W/G	-
15P	W/R	-

Connector No.	M6
Connector Name	WIRE TO WIRE
Connector Color	WHITE



4	3	2	1
8	7	6	5

Terminal No.	Color of Wire	Signal Name
7	W	-

Connector No.	M18
Connector Name	BCM (BODY CONTROL MODULE)
Connector Color	WHITE



1	2	3	4	5	6	7	8	9	10	11	12	13	14	15	16	17	18	19	20
21	22	23	24	25	26	27	28	29	30	31	32	33	34	35	36	37	38	39	40

Terminal No.	Color of Wire	Signal Name
2	P	INPUT 5
3	SB	INPUT 4

Terminal No.	Color of Wire	Signal Name
4	V	INPUT 3
5	L	INPUT 2
6	R	INPUT 1
32	O	OUTPUT 5
33	GR	OUTPUT 4
34	G	OUTPUT 3
35	BR	OUTPUT 2
36	LG	OUTPUT 1
38	W/R	IGN SW

Connector No.	M19
Connector Name	BCM (BODY CONTROL MODULE)
Connector Color	WHITE



41	42	43	44	45	46	47	48	49
50	51	52	53	54	55			

Terminal No.	Color of Wire	Signal Name
42	LG	GLASS HATCH SW
44	O	REAR WIPER AUTO STOP SW 1
55	W	REAR WIPER MOTOR OUTPUT 1

REAR WIPER AND WASHER SYSTEM

< WIRING DIAGRAM >

Terminal No.	Color of Wire	Signal Name
4	GR	INPUT 4
5	O	INPUT 5
6	R	OUTPUT 1
7	L	OUTPUT 2
8	P	OUTPUT 5
9	SB	OUTPUT 4
10	V	OUTPUT 3
11	O	WASHER MOTO (RR+)
12	B	GND
13	L	WASHER MOTO (RR-)
14	W/G	IGN

Connector No.	M28
Connector Name	COMBINATION SWITCH
Connector Color	WHITE

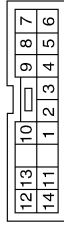

Terminal No.	Color of Wire	Signal Name
1	LG	INPUT 1
2	BR	INPUT 2
3	G	INPUT 3

Connector No.	M20
Connector Name	BCM (BODY CONTROL MODULE)
Connector Color	BLACK



Terminal No.	Color of Wire	Signal Name
67	B	GND (POWER)
70	W	BAT (F/L)

Terminal No.	Color of Wire	Signal Name
78G	O	-
79G	L	-

Connector No.	M31
Connector Name	WIRE TO WIRE
Connector Color	WHITE

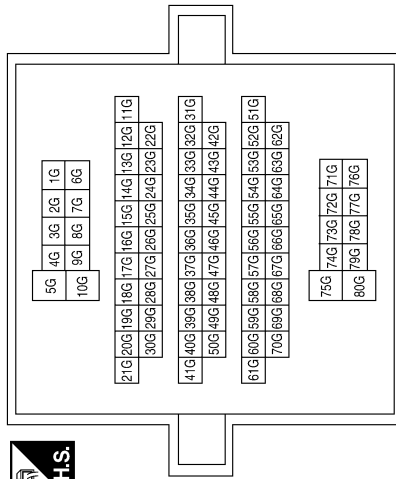

ABLIA0388GB

A B C D E F G H I J K L M N O P



REAR WIPER AND WASHER SYSTEM

< WIRING DIAGRAM >

Connector No.	E10
Connector Name	WIRE TO WIRE
Connector Color	WHITE

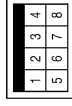

Terminal No.	Color of Wire	Signal Name
7	W	-

Terminal No.	Color of Wire	Signal Name
55J	O	-
56J	LG	-
74J	W	-

Connector No.	M40
Connector Name	WIRE TO WIRE
Connector Color	WHITE

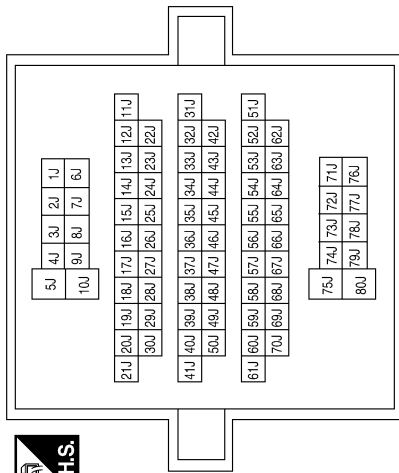

Connector No.	E152
Connector Name	WIRE TO WIRE
Connector Color	WHITE

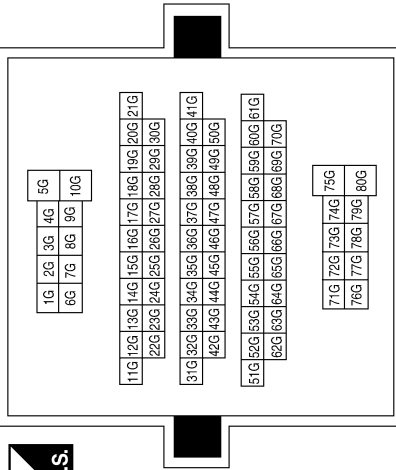

Connector No.	E105
Connector Name	FRONT AND REAR WASHER MOTOR
Connector Color	BLACK



Terminal No.	Color of Wire	Signal Name
1	L	-
2	O	-

ABLIA0389GB

REAR WIPER AND WASHER SYSTEM

< WIRING DIAGRAM >

Connector No.	B43
Connector Name	WIRE TO WIRE
Connector Color	WHITE

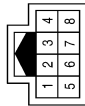

Terminal No.	Color of Wire	Signal Name
6	LG	-

Connector No.	B48
Connector Name	WIRE TO WIRE
Connector Color	WHITE



Terminal No.	Color of Wire	Signal Name
1	W	-
4	O	-

Connector No.	B69
Connector Name	WIRE TO WIRE
Connector Color	WHITE

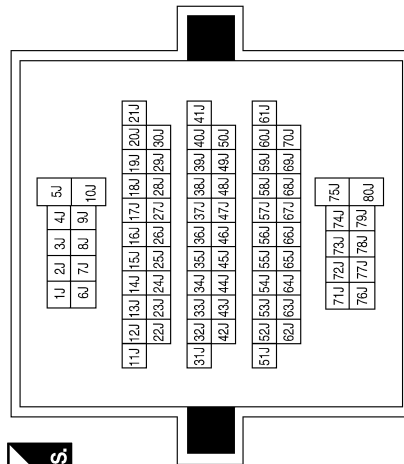

Terminal No.	Color of Wire	Signal Name
55J	O	-
56J	LG	-
74J	W	-

Connector No.	D401
Connector Name	WIRE TO WIRE
Connector Color	WHITE

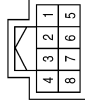

Terminal No.	Color of Wire	Signal Name
6	LG	-

ABLIA0390GB

A
B
C
D
E
F
G
H
I
J
K
M
N
O
P

WW

REAR WIPER AND WASHER SYSTEM

< WIRING DIAGRAM >

Connector No.	D405
Connector Name	WIRE TO WIRE
Connector Color	WHITE

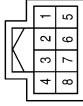

Terminal No.	Color of Wire	Signal Name
6	LG	-

Connector No.	D404
Connector Name	WIRE TO WIRE
Connector Color	WHITE

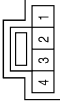

Terminal No.	Color of Wire	Signal Name
1	B	-

Connector No.	D402
Connector Name	WIRE TO WIRE
Connector Color	WHITE



Terminal No.	Color of Wire	Signal Name
1	W	-
4	O	-

Connector No.	D503
Connector Name	GLASS HATCH AJAR SWITCH
Connector Color	BLACK



Terminal No.	Color of Wire	Signal Name
1	LG	-

Connector No.	D501
Connector Name	WIRE TO WIRE
Connector Color	WHITE

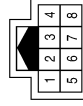

Terminal No.	Color of Wire	Signal Name
6	LG	-

Connector No.	D408
Connector Name	WIRE TO WIRE
Connector Color	WHITE

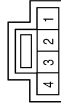

Terminal No.	Color of Wire	Signal Name
2	B	-
3	O	-
4	W	-

ALLIA0312GB

REAR WIPER AND WASHER SYSTEM

< WIRING DIAGRAM >

Connector No.	D602
Connector Name	REAR WIPER MOTOR
Connector Color	WHITE

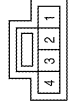

Terminal No.	Color of Wire	Signal Name
1	R	-
2	O	-
4	W	-

Connector No.	D601
Connector Name	WIRE TO WIRE
Connector Color	WHITE



Terminal No.	Color of Wire	Signal Name
2	R	-
3	O	-
4	W	-

Connector No.	D505
Connector Name	WIRE TO WIRE
Connector Color	WHITE



Terminal No.	Color of Wire	Signal Name
1	B	-

A
B
C
D
E
F
G
H
I
J
K
L
M
N
O
P

WW

ABLIA1653GB

WIPER AND WASHER SYSTEM SYMPTOMS

< SYMPTOM DIAGNOSIS >

SYMPTOM DIAGNOSIS

WIPER AND WASHER SYSTEM SYMPTOMS

Symptom Table

INFOID:000000007355300

CAUTION:

Perform the self-diagnosis with CONSULT before performing the diagnosis by symptom. Perform the diagnosis by DTC if DTC is detected.

Symptom	Probable malfunction location	Inspection item	
Front wiper does not operate.	HI only	<ul style="list-style-type: none"> Combination switch (wiper and washer switch) Harness between combination switch (wiper and washer switch) and BCM BCM 	Combination switch (wiper and washer switch) Refer to BCS-50, "Symptom Table" .
		<ul style="list-style-type: none"> IPDM E/R Harness between IPDM E/R and front wiper motor Front wiper motor 	Front wiper motor (HI) circuit Refer to WW-20, "Component Function Check" .
		Front wiper request signal <ul style="list-style-type: none"> BCM IPDM E/R 	IPDM E/R DATA MONITOR "FR WIP REQ"
	LO and INT	<ul style="list-style-type: none"> Combination switch (wiper and washer switch) Harness between combination switch (wiper and washer switch) and BCM BCM 	Combination switch (wiper and washer switch) Refer to BCS-50, "Symptom Table" .
		<ul style="list-style-type: none"> IPDM E/R Harness between IPDM E/R and front wiper motor Front wiper motor 	Front wiper motor (LO) circuit Refer to WW-18, "Component Function Check" .
		Front wiper request signal <ul style="list-style-type: none"> BCM IPDM E/R 	IPDM E/R DATA MONITOR "FR WIP REQ"
	INT only	<ul style="list-style-type: none"> Combination switch (wiper and washer switch) Harness between combination switch (wiper and washer switch) and BCM BCM 	Combination switch (wiper and washer switch) Refer to BCS-50, "Symptom Table" .
		Front wiper request signal <ul style="list-style-type: none"> BCM IPDM E/R 	IPDM E/R DATA MONITOR "FR WIP REQ"
	HI, LO, and INT	SYMPTOM DIAGNOSIS "FRONT WIPER DOES NOT OPERATE" Refer to WW-66, "Diagnosis Procedure" .	

WIPER AND WASHER SYSTEM SYMPTOMS

< SYMPTOM DIAGNOSIS >

Symptom	Probable malfunction location	Inspection item	
Front wiper does not stop.	HI only	<ul style="list-style-type: none"> • Combination switch (wiper and washer switch) • BCM 	Combination switch (wiper and washer switch) Refer to BCS-50, "Symptom Table" .
		Front wiper request signal <ul style="list-style-type: none"> • BCM • IPDM E/R 	IPDM E/R DATA MONITOR "FR WIP REQ"
		IPDM E/R	—
	LO only	<ul style="list-style-type: none"> • Combination switch (wiper and washer switch) • BCM 	Combination switch (wiper and washer switch) Refer to BCS-50, "Symptom Table" .
		Front wiper request signal <ul style="list-style-type: none"> • BCM • IPDM E/R 	IPDM E/R DATA MONITOR "FR WIP REQ"
		IPDM E/R	—
	INT only	<ul style="list-style-type: none"> • Combination switch (wiper and washer switch) • BCM 	Combination switch (wiper and washer switch) Refer to BCS-50, "Symptom Table" .
		Front wiper request signal <ul style="list-style-type: none"> • BCM • IPDM E/R 	IPDM E/R DATA MONITOR "FR WIP REQ"
	Front wiper does not operate normally.	Intermittent adjustment cannot be performed.	<ul style="list-style-type: none"> • Combination switch (wiper and washer switch) • Harness between combination switch (wiper and washer switch) and BCM • BCM
BCM			—
Intermittent control linked with vehicle speed cannot be performed.		Check the vehicle speed detection wiper setting. Refer to BCS-22, "WIPER : CONSULT Function (BCM - WIPER)" .	
Wiper is not linked to the washer operation.		<ul style="list-style-type: none"> • Combination switch (wiper and washer switch) • Harness between combination switch (wiper and washer switch) and BCM • BCM 	Combination switch (wiper and washer switch) Refer to BCS-50, "Symptom Table" .
		BCM	—
Does not return to stop position (Repeatedly operates for 10 seconds and then stops for 20 seconds. After that, it stops the operation).	<ul style="list-style-type: none"> • IPDM E/R • Harness between IPDM E/R and front wiper motor • Front wiper motor 	Front wiper auto stop signal circuit Refer to WW-22, "Component Function Check" .	

A
B
C
D
E
F
G
H
I
J
K
M
N
O
P

WW

WIPER AND WASHER SYSTEM SYMPTOMS

< SYMPTOM DIAGNOSIS >

Symptom		Probable malfunction location	Inspection item
Rear wiper does not operate.	ON only	<ul style="list-style-type: none"> • Combination switch (wiper and washer switch) • Harness between combination switch (wiper and washer switch) and BCM • BCM 	Combination switch (wiper and washer switch) Refer to BCS-50, "Symptom Table" .
	INT only	<ul style="list-style-type: none"> • Combination switch (wiper and washer switch) • Harness between combination switch (wiper and washer switch) and BCM • BCM 	Combination switch (wiper and washer switch) Refer to BCS-50, "Symptom Table" .
	ON and INT	<ul style="list-style-type: none"> • Combination switch (wiper and washer switch) • Harness between combination switch (wiper and washer switch) and BCM • BCM 	Combination switch (wiper and washer switch) Refer to BCS-50, "Symptom Table" .
Rear wiper does not stop.	ON only	<ul style="list-style-type: none"> • Combination switch (wiper and washer switch) • BCM 	Rear wiper motor circuit Refer to WW-29, "Component Function Check" .
	INT only	<ul style="list-style-type: none"> • Combination switch (wiper and washer switch) • BCM 	Combination switch (wiper and washer switch) Refer to BCS-50, "Symptom Table" .
Rear wiper does not operate normally.	Wiper is not linked to the washer operation.	<ul style="list-style-type: none"> • Combination switch (wiper and washer switch) • Harness between rear wiper motor and BCM • BCM 	Combination switch (wiper and washer switch) Refer to BCS-50, "Symptom Table" .
		BCM	—
	<ul style="list-style-type: none"> • BCM • Harness between rear wiper motor and BCM • Rear wiper motor 	<ul style="list-style-type: none"> • Rear wiper does not return to the Stop position (Stops after a five-second operation). • Rear wiper stops after operating for five seconds when ignition switch is turned ON. 	Rear wiper auto stop signal circuit Refer to WW-31, "Component Function Check" .

NORMAL OPERATING CONDITION

< SYMPTOM DIAGNOSIS >

NORMAL OPERATING CONDITION

Description

INFOID:000000007355301

FRONT WIPER MOTOR PROTECTION FUNCTION

- IPDM E/R may stop the front wiper to protect the front wiper motor if any obstruction (operation resistance) such as a large amount of snow is detected during the front wiper operation.
- At that time turn OFF the front wiper and remove the foreign object. Then wait for approximately 20 seconds or more and reactivate the front wiper. The wiper will operate normally.

REAR WIPER MOTOR PROTECTION FUNCTION

- BCM may stop rear wiper to protect the rear wiper motor when the rear wiper is stopped for 5 seconds or more due to a snowfall.
- Rear wiper operates normally one minute after the obstacles are removed with rear wiper OFF.

A
B
C
D
E
F
G
H
I
J
K
M
N
O
P

WW

FRONT WIPER DOES NOT OPERATE

< SYMPTOM DIAGNOSIS >

FRONT WIPER DOES NOT OPERATE

Description

INFOID:000000007355302

The front wiper does not operate under any operation conditions.

Diagnosis Procedure

INFOID:000000007355303

Regarding Wiring Diagram information, refer to [WW-50, "Wiring Diagram"](#).

1. CHECK WIPER RELAY OPERATION

⊗ IPDM E/R AUTO ACTIVE TEST

1. Start IPDM E/R auto active test. Refer to [PCS-9, "Diagnosis Description"](#).
2. Check that the front wiper operates at the LO/HI operation.

Ⓟ WITH CONSULT ACTIVE TEST

1. Select "FRONT WIPER" of IPDM E/R active test item.
2. While operating the test item, check front wiper operation.

LO : Front wiper LO operation

HI : Front wiper HI operation

OFF : Stop the front wiper.

Is front wiper operation normal?

YES >> GO TO 5

NO >> GO TO 2

2. CHECK FRONT WIPER MOTOR FUSE

1. Turn the ignition switch OFF.
2. Check that the following fuse is not blown.

Unit	Location	Fuse No.	Capacity
Front wiper motor	IPDM E/R	39	30 A

Is the fuse blown?

YES >> Replace the fuse after repairing the affected circuit.

NO >> GO TO 3

3. CHECK FRONT WIPER MOTOR GROUND OPEN CIRCUIT

1. Disconnect front wiper motor.
2. Check continuity between front wiper motor harness connector and ground.

Front wiper motor		Ground	Continuity
Connector	Terminal		
E23	2		Yes

Does continuity exist?

YES >> GO TO 4

NO >> Repair or replace harness.

4. CHECK FRONT WIPER MOTOR OUTPUT VOLTAGE

Ⓟ WITH CONSULT ACTIVE TEST

FRONT WIPER DOES NOT OPERATE

< SYMPTOM DIAGNOSIS >

1. Turn the ignition switch ON.
2. Select "FRONT WIPER" of IPDM E/R active test item.
3. With operating the test item, check voltage between IPDM E/R harness connector and ground.

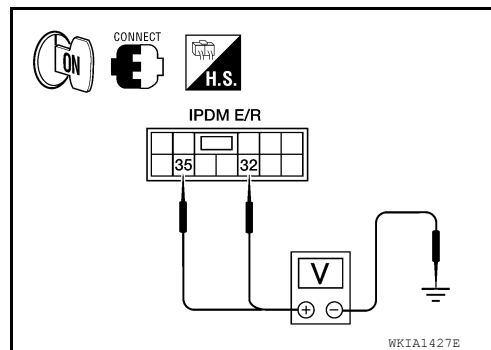

Terminals		Test item	Voltage (Approx.)
(+)	(-)		
IPDM E/R		FRONT WIPER	Battery voltage
Connector	Terminal		
E121	32	LO	0 V
		HI	Battery voltage
	35	OFF	0 V

Is the measurement value normal?

- YES >> Replace front wiper motor. Refer to [WW-70, "Removal and Installation"](#).
 NO >> Replace IPDM E/R. Refer to [PCS-29, "Removal and Installation of IPDM E/R"](#).

5. CHECK FRONT WIPER REQUEST SIGNAL INPUT

Ⓜ WITH CONSULT DATA MONITOR

1. Select "FR WIP REQ" of IPDM E/R data monitor item.
2. Switch the front wiper switch to HI and LO.
3. With operating the front wiper switch, check the status of "FR WIP REQ".

Monitor item	Condition	Monitor status	
FR WIP REQ	Front wiper switch HI	HI	ON
		STOP	OFF
	Front wiper switch LO	1LOW	ON
		STOP	OFF

Is the status of item normal?

- YES >> Replace IPDM E/R. Refer to [PCS-29, "Removal and Installation of IPDM E/R"](#).
 NO >> GO TO 6

6. CHECK COMBINATION SWITCH (WIPER AND WASHER SWITCH)

1. Perform the inspection of the combination switch (wiper and washer switch). Refer to [BCS-50, "Symptom Table"](#).

Is combination switch (wiper and washer switch) normal?

- YES >> Replace BCM. Refer to [BCS-53, "Removal and Installation"](#).
 NO >> Repair or replace the affected parts.

WW

PRECAUTION

< PRECAUTION >

PRECAUTION

PRECAUTION

Precaution for Supplemental Restraint System (SRS) "AIR BAG" and "SEAT BELT PRE-TENSIONER"

INFOID:000000007355304

The Supplemental Restraint System such as "AIR BAG" and "SEAT BELT PRE-TENSIONER", used along with a front seat belt, helps to reduce the risk or severity of injury to the driver and front passenger for certain types of collision. This system includes seat belt switch inputs and dual stage front air bag modules. The SRS system uses the seat belt switches to determine the front air bag deployment, and may only deploy one front air bag, depending on the severity of a collision and whether the front occupants are belted or unbelted. Information necessary to service the system safely is included in the SR and SB section of this Service Manual.

WARNING:

- To avoid rendering the SRS inoperative, which could increase the risk of personal injury or death in the event of a collision which would result in air bag inflation, all maintenance must be performed by an authorized NISSAN/INFINITI dealer.
- Improper maintenance, including incorrect removal and installation of the SRS, can lead to personal injury caused by unintentional activation of the system. For removal of Spiral Cable and Air Bag Module, see the SR section.
- Do not use electrical test equipment on any circuit related to the SRS unless instructed to in this Service Manual. SRS wiring harnesses can be identified by yellow and/or orange harnesses or harness connectors.

PRECAUTIONS WHEN USING POWER TOOLS (AIR OR ELECTRIC) AND HAMMERS

WARNING:

- When working near the Airbag Diagnosis Sensor Unit or other Airbag System sensors with the Ignition ON or engine running, DO NOT use air or electric power tools or strike near the sensor(s) with a hammer. Heavy vibration could activate the sensor(s) and deploy the air bag(s), possibly causing serious injury.
- When using air or electric power tools or hammers, always switch the Ignition OFF, disconnect the battery, and wait at least 3 minutes before performing any service.

Precaution Necessary for Steering Wheel Rotation After Battery Disconnect

INFOID:000000007355305

NOTE:

- This Procedure is applied only to models with Intelligent Key system and NATS (NISSAN ANTI-THEFT SYSTEM).
- Remove and install all control units after disconnecting both battery cables with the ignition knob in the "LOCK" position.
- Always use CONSULT to perform self-diagnosis as a part of each function inspection after finishing work. If DTC is detected, perform trouble diagnosis according to self-diagnostic results.

For models equipped with the Intelligent Key system and NATS, an electrically controlled steering lock mechanism is adopted on the key cylinder.

For this reason, if the battery is disconnected or if the battery is discharged, the steering wheel will lock and steering wheel rotation will become impossible.

If steering wheel rotation is required when battery power is interrupted, follow the procedure below before starting the repair operation.

OPERATION PROCEDURE

1. Connect both battery cables.

NOTE:

Supply power using jumper cables if battery is discharged.

2. Use the Intelligent Key or mechanical key to turn the ignition switch to the "ACC" position. At this time, the steering lock will be released.
3. Disconnect both battery cables. The steering lock will remain released and the steering wheel can be rotated.
4. Perform the necessary repair operation.

PRECAUTION

< PRECAUTION >

5. When the repair work is completed, return the ignition switch to the "LOCK" position before connecting the battery cables. (At this time, the steering lock mechanism will engage.)
6. Perform a self-diagnosis check of all control units using CONSULT.

A

B

C

D

E

F

G

H

I

J

K

WW

M

N

O

P

FRONT WIPER AND WASHER SYSTEM

< REMOVAL AND INSTALLATION >

REMOVAL AND INSTALLATION

FRONT WIPER AND WASHER SYSTEM

Removal and Installation

INFOID:000000007355306

FRONT WIPER ARMS

Removal

1. Remove wiper arm covers and wiper arm nuts.
2. Remove front RH wiper arm and front LH wiper arm.
3. Remove front RH and LH blade assembly from the front RH and LH arm assembly.

Installation

1. Operate wiper motor one full cycle, then turn "OFF" (Auto Stop).
2. Clean up the pivot area as shown. This will reduce possibility of wiper arm looseness.

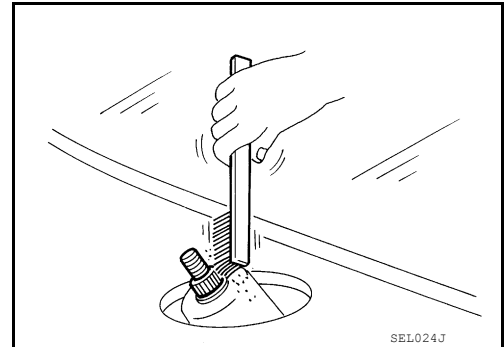

3. Install front RH and LH blade assembly on the front RH and LH arm.
4. Install front RH wiper arm and front LH wiper arm.
5. Ensure that wiper blades stop within proper clearance.

FRONT WIPER ARM ADJUSTMENT

1. Operate windshield washer and wiper motor one full cycle, then turn "OFF" (Auto Stop).
2. Lift the wiper blade up and then rest it onto glass surface, check the blade clearance "L1" and "L2".

Clearance "L1" : 24.5 - 39.5 mm (0.965 - 1.555 in)

Clearance "L2" : 23.5 - 38.5 mm (0.925 - 1.516 in)

3. Remove wiper arm covers and wiper arm nuts.
4. Adjust front wiper arms on wiper motor pivot shafts to obtain above specified blade clearances.
5. Tighten wiper arm nuts to specified torque, and install wiper arm covers.

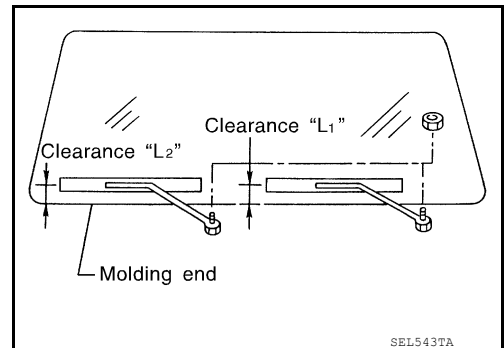

Front wiper arm nuts : 23.5 N·m (2.4 kg-m, 17 ft-lb)

FRONT WIPER AND WASHER SYSTEM

< REMOVAL AND INSTALLATION >

WIPER MOTOR AND LINKAGE

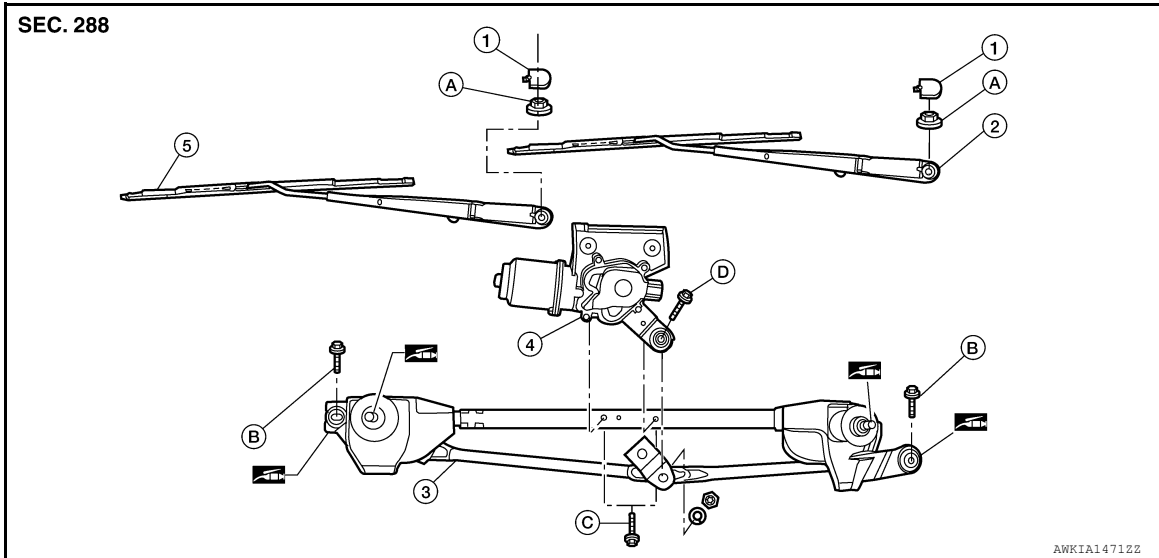

- | | | |
|--------------------------|--|-------------------------------|
| 1. Wiper arm covers | 2. Front LH wiper arm and blade assembly | 3. Wiper frame assembly |
| 4. Wiper motor | 5. Front RH wiper arm and blade assembly | A. Wiper arm nuts |
| B. Wiper arm frame bolts | C. Wiper motor bolts | D. Wiper motor pivot arm bolt |

Removal

1. Remove the cowl top. Refer to [EXT-21, "Removal and Installation"](#).
2. Remove wiper frame bolts, disconnect the wiper motor connector and remove the wiper frame assembly.

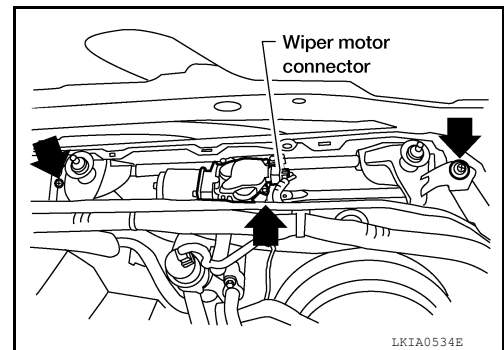

3. Remove wiper motor from wiper frame assembly.

Installation

CAUTION:

- Do not drop the wiper motor or cause it to contact other parts.
 - Check the grease conditions of the motor arm and wiper link joint(s). Apply grease if necessary.
1. Connect wiper motor to connector. Turn the wiper switch ON to operate wiper motor, then turn the wiper switch OFF (auto stop).
 2. Disconnect wiper motor electrical connector.
 3. Install wiper motor to wiper frame assembly, and install wiper frame assembly.
 4. Connect wiper motor electrical connector.
 5. Install cowl top. Refer to [EXT-21, "Removal and Installation"](#).

FRONT WIPER AND WASHER SYSTEM

< REMOVAL AND INSTALLATION >

WASHER HOSE LAYOUT

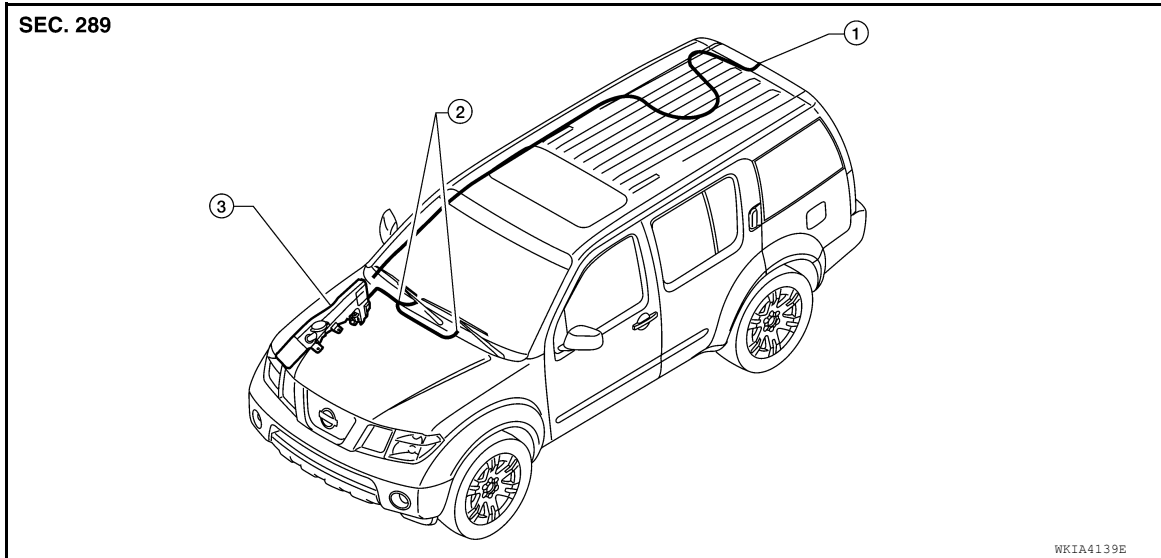

1. Rear washer nozzle

2. Washer nozzles

3. Washer fluid reservoir

WASHER NOZZLES

Removal

1. Remove the cowl top. Refer to [EXT-21, "Removal and Installation"](#).
2. Remove washer nozzles.

Installation

Installation is in the reverse order of removal.

WIPER AND WASHER SWITCH

Removal

1. Remove instrument lower panel LH. Refer to [IP-15, "Removal and Installation"](#).
2. Remove steering column cover lower and steering column cover upper.
3. Disconnect wiper and washer switch connector.
4. Pinch tabs at wiper and washer switch base and slide switch away from steering column.

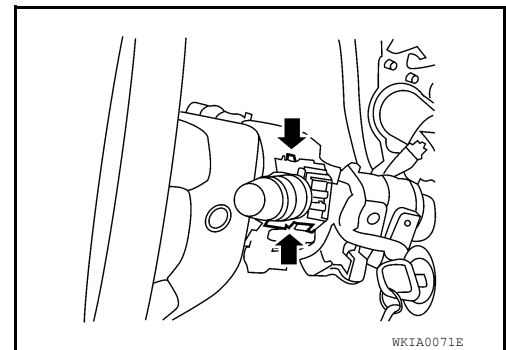

Installation

Installation is in the reverse order of removal.

WASHER FLUID RESERVOIR

Removal

1. Remove the front fender protector RH. Refer to [EXT-25, "Removal and Installation of Front Fender Protector"](#).

FRONT WIPER AND WASHER SYSTEM

< REMOVAL AND INSTALLATION >

2. Remove clip, then remove washer fluid reservoir filler neck from washer fluid reservoir.

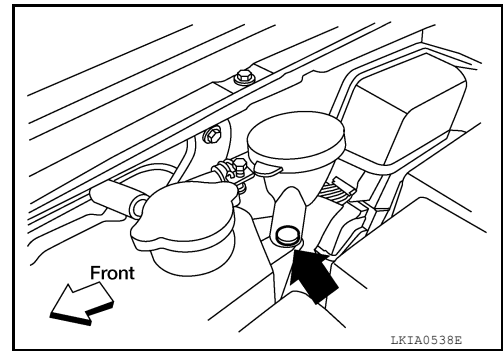

3. Disconnect front and rear washer hoses.
4. Disconnect front and rear washer motor connector.
5. Disconnect washer fluid level sensor connector.

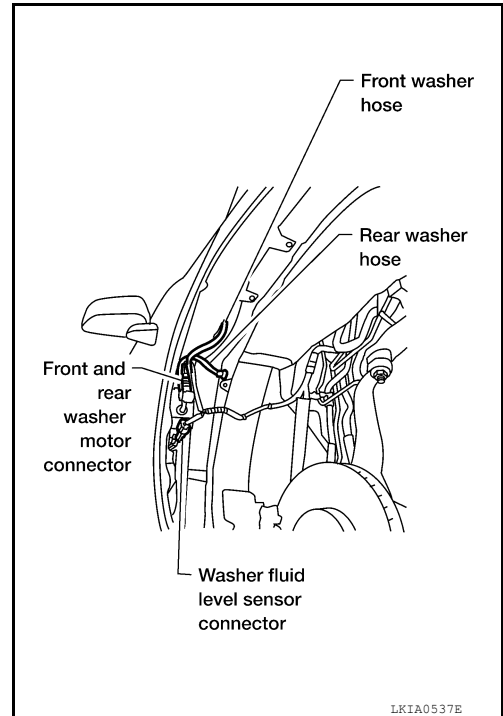

6. Remove washer fluid reservoir screws and remove washer fluid reservoir.

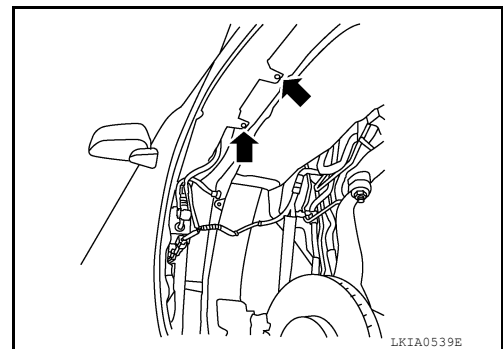

Installation

Installation is in the reverse order of removal.

CAUTION:

After installation, add water up to the upper level of the washer fluid reservoir inlet and check for water leaks.

WASHER MOTOR

Removal

1. Remove RH front fender protector. Refer to [EXT-25. "Removal and Installation of Front Fender Protector"](#).
2. Disconnect the front washer hoses.
3. Disconnect the front washer motor connectors.

A
B
C
D
E
F
G
H
I
J
K
WW
M
N
O
P

FRONT WIPER AND WASHER SYSTEM

< REMOVAL AND INSTALLATION >

- Slide retaining ring upward to release front and rear washer motor.

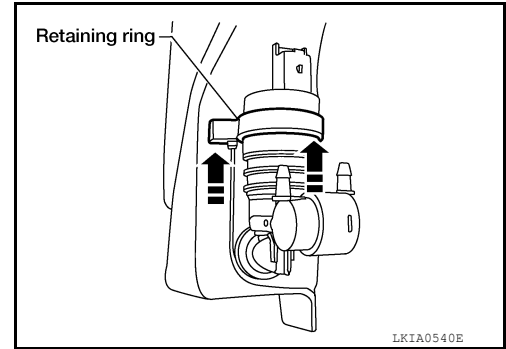

- Remove front washer motor from washer fluid reservoir.

Installation

Installation is in the reverse order of removal.

CAUTION:

When installing front washer motor, there should be no packing twists, etc.

WASHER FLUID LEVEL SENSOR

Removal

- Remove washer fluid reservoir.
- Lift level sensor out of washer fluid reservoir in the direction of the arrow as shown.

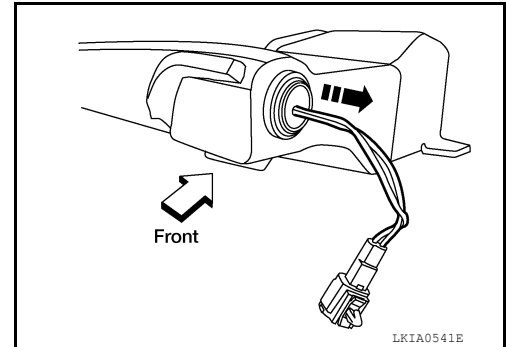

Installation

Installation is in the reverse order of removal.

Washer Nozzle Adjustment

INFOID:000000007355307

- This vehicle is equipped with non-adjustable washer nozzles.
- If not satisfied with washer fluid spray coverage, confirm that the washer nozzle is installed correctly.
- If the washer nozzle is installed correctly, and the washer fluid spray coverage is not satisfactory, replace the washer nozzle.

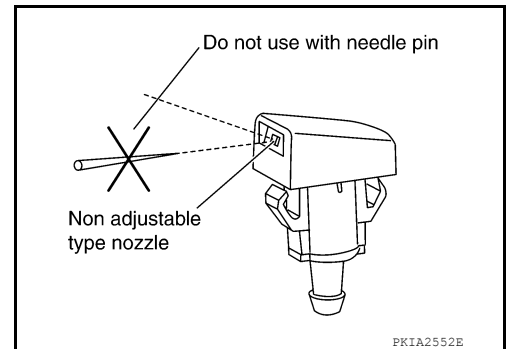

REAR WIPER AND WASHER SYSTEM

< REMOVAL AND INSTALLATION >

REAR WIPER AND WASHER SYSTEM

Removal and Installation

INFOID:000000007355308

REAR WIPER ARM

Removal

1. Remove wiper arm cover, and remove rear wiper arm nut.
2. Remove the wiper arm.
3. Remove wiper blade from the wiper arm.

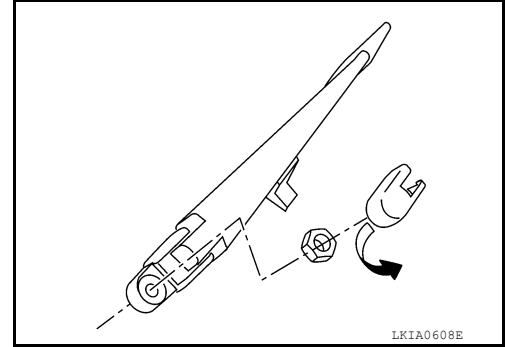

Installation

1. Operate rear wiper motor one full cycle, then turn "OFF" (Auto Stop).
2. Clean pivot area as shown. This will reduce the possibility of wiper arm looseness.

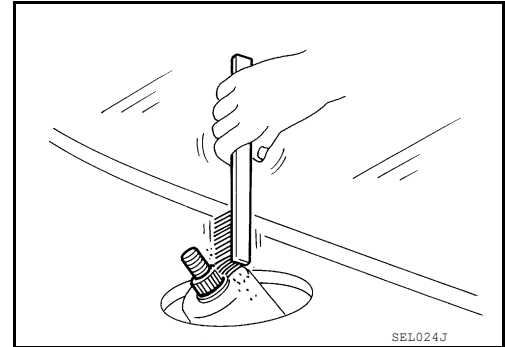

3. Install wiper blade on the wiper arm.
4. Install wiper arm so that the arm rests in the stopper and tighten rear wiper arm nut.
5. Install wiper arm cover.

REAR WIPER MOTOR

A
B
C
D
E
F
G
H
I
J
K
M
N
O
P

WW

REAR WIPER AND WASHER SYSTEM

< REMOVAL AND INSTALLATION >

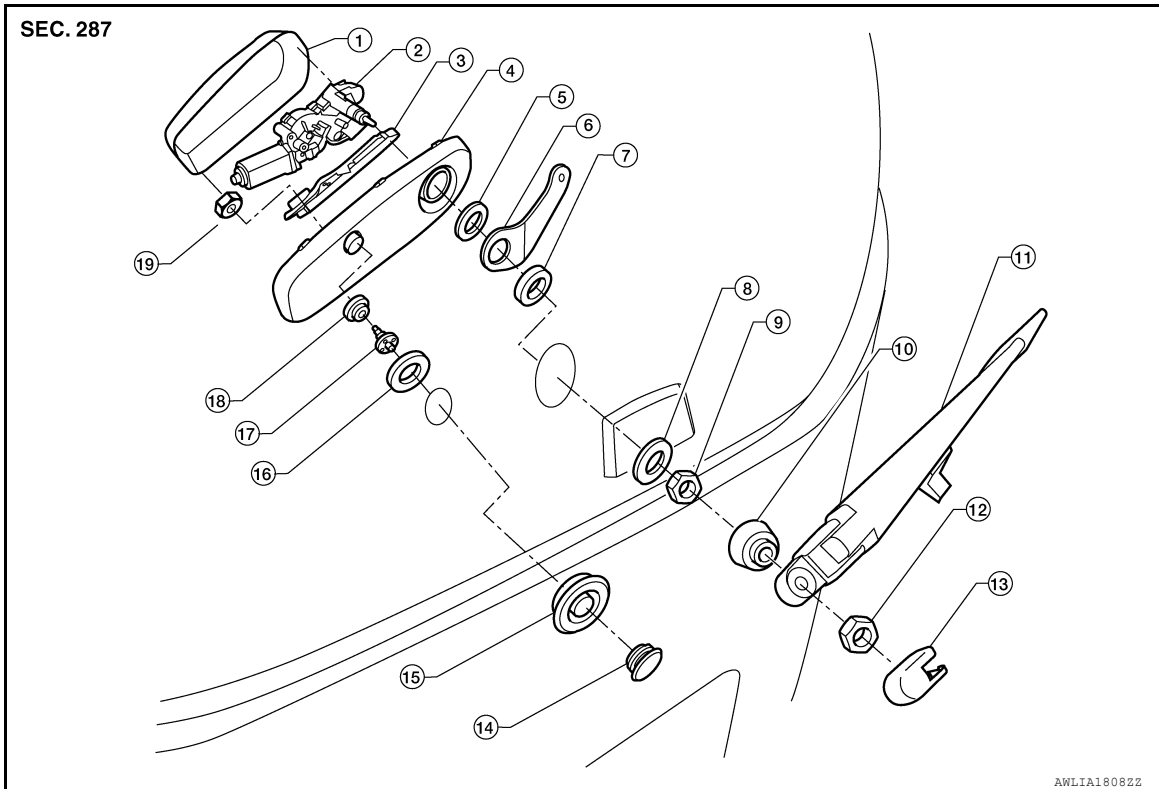

- | | | |
|--------------------------------|------------------------------|-------------------------|
| 1. Rear wiper motor cover | 2. Rear wiper motor | 3. Plate |
| 4. Rear wiper motor cover base | 5. Spacer | 6. Bracket |
| 7. Grommet | 8. Washer | 9. Rear wiper motor nut |
| 10. Pivot cap | 11. Rear wiper arm and blade | 12. Wiper arm nut |
| 13. Wiper arm cover | 14. Cap nut | 15. Gasket |
| 16. Gasket | 17. Stud | 18. Grommet |
| 19. Nut | | |

Removal

1. Remove wiper arm. Refer to [WW-75, "Removal and Installation"](#).
2. Remove pivot cap.
3. Remove rear wiper motor nut.
4. Remove rear wiper motor cover.
5. Disconnect rear wiper motor connector.
6. Remove nut and remove rear wiper motor.

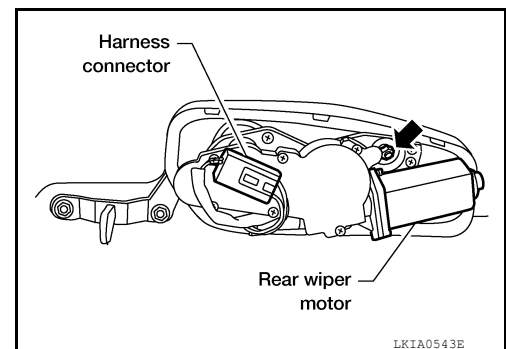

7. Remove rear wiper motor cover base.
8. Remove bracket.

Installation

CAUTION:

- Do not drop the wiper motor or cause it to contact other parts.
- Installation is in the reverse order of removal.

REAR WIPER AND WASHER SYSTEM

< REMOVAL AND INSTALLATION >

REAR WASHER TUBE LAYOUT

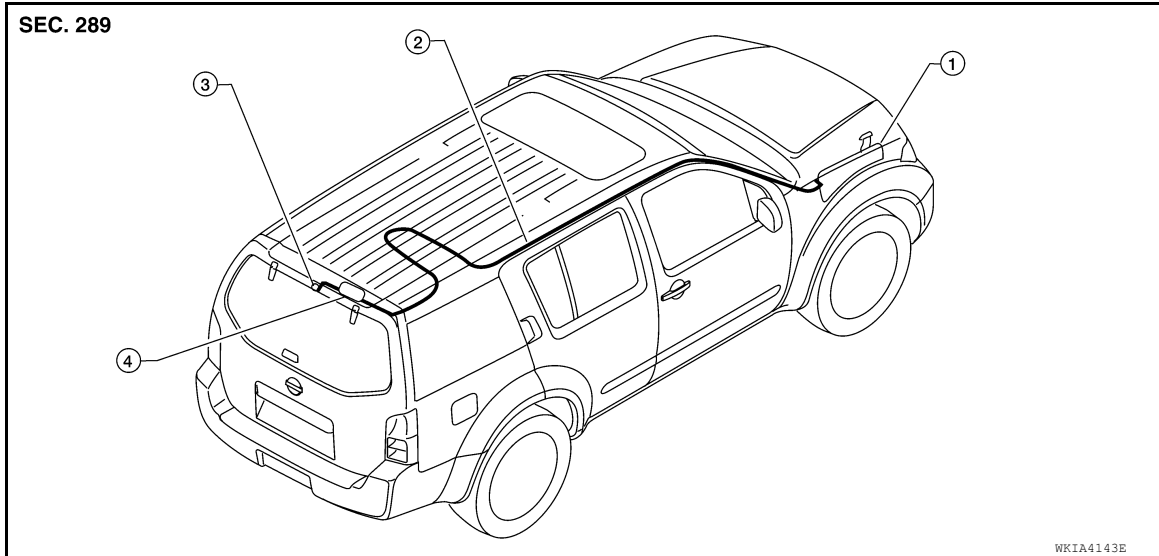

1. Washer fluid reservoir
2. Washer fluid tube to rear door
3. Rear washer nozzle
4. Check valve

NOTE:

Connect the check valve (2) to the washer fluid tube (1) so that the directional arrow on the check valve (2) points towards the washer nozzle tube (3).

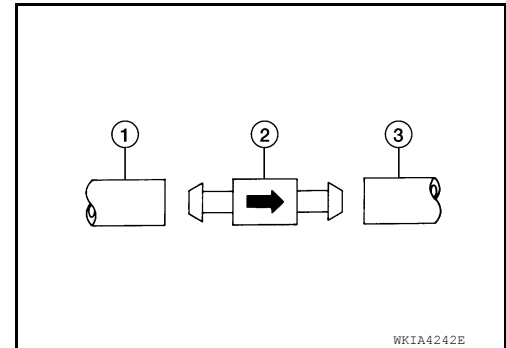

REAR WASHER NOZZLE

Removal

1. Disconnect rear washer tube from rear washer nozzle.
2. Release retaining clips and remove washer nozzle.

Installation

Installation is in the reverse order of removal.

NOTE:

Inspect rear washer nozzle for proper spray pattern, adjust as necessary. Refer to [WW-78, "Rear Washer Nozzle Adjustment"](#).

WASHER MOTOR

Removal

1. Remove RH front fender protector. Refer to [EXT-25, "Removal and Installation of Front Fender Protector"](#).
2. Disconnect the rear washer hoses.
3. Disconnect the rear washer motor connectors.

REAR WIPER AND WASHER SYSTEM

< REMOVAL AND INSTALLATION >

4. Slide retaining ring upward to release rear washer motor.

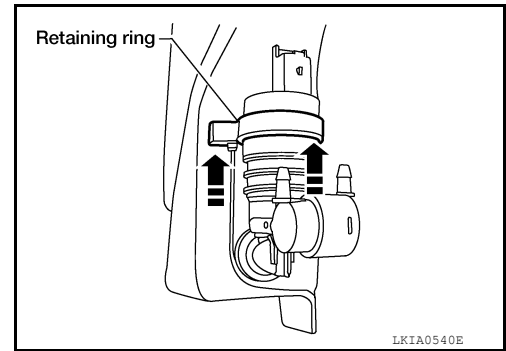

5. Remove rear washer motor from washer fluid reservoir.

Installation

Installation is in the reverse order of removal.

CAUTION:

When installing rear washer motor, there should be no packing twists, etc.

WASHER MOTOR

Refer to [WW-70](#).

Rear Washer Nozzle Adjustment

INFOID:000000007355309

• Adjust washer nozzle with suitable tool as shown in the figure.

Adjustable range : $\pm 15^\circ$ (In any direction)

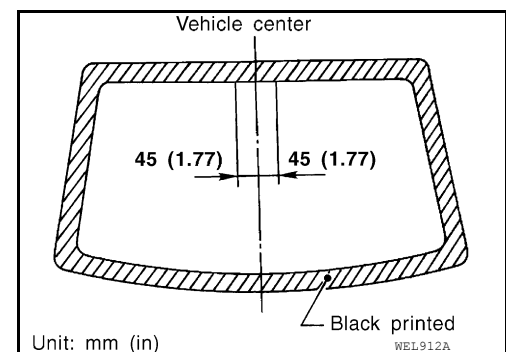
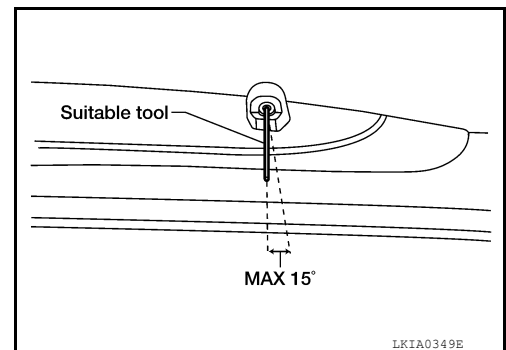

SERVICE DATA AND SPECIFICATIONS (SDS)

< SERVICE DATA AND SPECIFICATIONS (SDS)

SERVICE DATA AND SPECIFICATIONS (SDS)

SERVICE DATA AND SPECIFICATIONS (SDS)

Specifications

INFOID:000000007355310

Windshield Washer Fluid

Windshield washer fluid capacity	4.5 ℓ (1 1/4 US gal, 1 Imp gal)
Windshield washer fluid specification	Refer to MA-18. "FOR USA AND CANADA : Fluids and Lubricants" (United States and Canada), MA-20. "FOR MEXICO : Fluids and Lubricants" (Mexico).

A
B
C
D
E
F
G
H
I
J
K
M
N
O
P

WW