

SECTION **ADP**

AUTOMATIC DRIVE POSITIONER

A
B
C
D
E
F
G
H
I
K
L
M
N
O
P

CONTENTS

<p>PRECAUTION 5</p> <p>PRECAUTIONS 5</p> <p style="padding-left: 20px;">Precaution for Supplemental Restraint System (SRS) "AIR BAG" and "SEAT BELT PRE-TENSIONER"5</p> <p style="padding-left: 20px;">Precaution for Work5</p> <p>PREPARATION 6</p> <p>PREPARATION 6</p> <p style="padding-left: 20px;">Special Service Tool6</p> <p>SYSTEM DESCRIPTION 7</p> <p>COMPONENT PARTS 7</p> <p style="padding-left: 20px;">Component Parts Location7</p> <p style="padding-left: 20px;">Component Description8</p> <p>SYSTEM11</p> <p>AUTOMATIC DRIVE POSITIONER SYSTEM 11</p> <p style="padding-left: 20px;">AUTOMATIC DRIVE POSITIONER SYSTEM : System Diagram 11</p> <p style="padding-left: 20px;">AUTOMATIC DRIVE POSITIONER SYSTEM : System Description 11</p> <p>MANUAL FUNCTION12</p> <p style="padding-left: 20px;">MANUAL FUNCTION : System Diagram 13</p> <p style="padding-left: 20px;">MANUAL FUNCTION : System Description 13</p> <p>MEMORY FUNCTION 14</p> <p style="padding-left: 20px;">MEMORY FUNCTION : System Diagram 15</p> <p style="padding-left: 20px;">MEMORY FUNCTION : System Description 15</p> <p>EXIT ASSIST FUNCTION16</p> <p style="padding-left: 20px;">EXIT ASSIST FUNCTION : System Diagram 17</p> <p style="padding-left: 20px;">EXIT ASSIST FUNCTION : System Description 17</p> <p>ENTRY ASSIST FUNCTION18</p> <p style="padding-left: 20px;">ENTRY ASSIST FUNCTION : System Diagram 18</p> <p style="padding-left: 20px;">ENTRY ASSIST FUNCTION : System Description 18</p>	<p>INTELLIGENT KEY INTERLOCK FUNCTION19</p> <p style="padding-left: 20px;">INTELLIGENT KEY INTERLOCK FUNCTION : System Diagram19</p> <p style="padding-left: 20px;">INTELLIGENT KEY INTERLOCK FUNCTION : System Description19</p> <p style="padding-left: 20px;">Fail Safe20</p> <p>DIAGNOSIS SYSTEM (DRIVER SEAT CONTROL UNIT)22</p> <p style="padding-left: 20px;">CONSULT Function22</p> <p>ECU DIAGNOSIS INFORMATION25</p> <p>DRIVER SEAT CONTROL UNIT25</p> <p style="padding-left: 20px;">Reference Value25</p> <p style="padding-left: 20px;">Fail Safe30</p> <p style="padding-left: 20px;">DTC Index31</p> <p>AUTOMATIC DRIVE POSITIONER CONTROL UNIT32</p> <p style="padding-left: 20px;">Reference Value32</p> <p>BCM (BODY CONTROL MODULE)35</p> <p style="padding-left: 20px;">List of ECU Reference35</p> <p>WIRING DIAGRAM36</p> <p>AUTOMATIC DRIVE POSITIONER SYSTEM ...36</p> <p>WITHOUT AROUND VIEW MONITOR36</p> <p style="padding-left: 20px;">WITHOUT AROUND VIEW MONITOR : Wiring Diagram 36</p> <p>WITH AROUND VIEW MONITOR49</p> <p style="padding-left: 20px;">WITH AROUND VIEW MONITOR : Wiring Diagram50</p> <p>BASIC INSPECTION64</p> <p>DIAGNOSIS AND REPAIR WORK FLOW64</p> <p style="padding-left: 20px;">Work Flow64</p> <p>INSPECTION AND ADJUSTMENT67</p>
---	--

ADP

ADDITIONAL SERVICE WHEN REMOVING BATTERY NEGATIVE TERMINAL	67	Description	80
ADDITIONAL SERVICE WHEN REMOVING BATTERY NEGATIVE TERMINAL : Description ...	67	DTC Logic	80
ADDITIONAL SERVICE WHEN REMOVING BATTERY NEGATIVE TERMINAL : Work Procedure	67	Diagnosis Procedure	80
ADDITIONAL SERVICE WHEN REPLACING CONTROL UNIT	67	B2130 EEPROM	82
ADDITIONAL SERVICE WHEN REPLACING CONTROL UNIT : Description	67	DTC Logic	82
ADDITIONAL SERVICE WHEN REPLACING CONTROL UNIT : Work Procedure	68	Diagnosis Procedure	82
SYSTEM INITIALIZATION	68	POWER SUPPLY AND GROUND CIRCUIT	83
SYSTEM INITIALIZATION : Description	68	BCM	83
SYSTEM INITIALIZATION : Work Procedure	68	BCM : Diagnosis Procedure	83
MEMORY STORING	69	DRIVER SEAT CONTROL UNIT	83
MEMORY STORING : Description	69	DRIVER SEAT CONTROL UNIT :	
MEMORY STORING : Work Procedure	69	Diagnosis Procedure	83
INTELLIGENT KEY INTERLOCK STORING	69	DRIVER SEAT CONTROL UNIT : Special Repair Requirement	84
INTELLIGENT KEY INTERLOCK STORING : Description	69	AUTOMATIC DRIVE POSITIONER CONTROL UNIT	84
INTELLIGENT KEY INTERLOCK STORING : Work Procedure	70	AUTOMATIC DRIVE POSITIONER CONTROL UNIT : Diagnosis Procedure	84
SYSTEM SETTING	70	AUTOMATIC DRIVE POSITIONER CONTROL UNIT : Special Repair Requirement	85
SYSTEM SETTING : Description	70	SLIDING SWITCH	86
SYSTEM SETTING : Work Procedure	70	Description	86
DTC/CIRCUIT DIAGNOSIS	72	Component Function Check	86
U1000 CAN COMM CIRCUIT	72	Diagnosis Procedure	86
Description	72	Component Inspection	87
DTC Logic	72	RECLINING SWITCH	89
Diagnosis Procedure	72	Description	89
Special Repair Requirement	72	Component Function Check	89
U1010 CONTROL UNIT (CAN)	73	Diagnosis Procedure	89
Description	73	Component Inspection	90
DTC Logic	73	LIFTING SWITCH (FRONT)	92
Diagnosis Procedure	73	Description	92
B2112 SLIDING MOTOR	74	Component Function Check	92
Description	74	Diagnosis Procedure	92
DTC Logic	74	Component Inspection	93
Diagnosis Procedure	74	LIFTING SWITCH (REAR)	95
B2113 RECLINING MOTOR	76	Description	95
Description	76	Component Function Check	95
DTC Logic	76	Diagnosis Procedure	95
Diagnosis Procedure	76	Component Inspection	96
B2116 TILT MOTOR	78	TILT SWITCH	98
Description	78	Description	98
DTC Logic	78	Component Function Check	98
Diagnosis Procedure	78	Diagnosis Procedure	98
B2128 UART COMMUNICATION LINE	80	Component Inspection	99
		TELESCOPIC SWITCH	100
		Description	100
		Component Function Check	100
		Diagnosis Procedure	100
		Component Inspection	101

SEAT MEMORY SWITCH	102	DRIVER SIDE	130	
Description	102	DRIVER SIDE : Description	130	A
Component Function Check	102	DRIVER SIDE : Component Function Check	130	
Diagnosis Procedure	102	DRIVER SIDE : Diagnosis Procedure	130	
Component Inspection	103			
DOOR MIRROR REMOTE CONTROL SWITCH	105	PASSENGER SIDE	132	B
CHANGEOVER SWITCH	105	PASSENGER SIDE : Description	132	
CHANGEOVER SWITCH : Description	105	PASSENGER SIDE :		
CHANGEOVER SWITCH :		Component Function Check	132	C
Component Function Check	105	PASSENGER SIDE : Diagnosis Procedure	132	
CHANGEOVER SWITCH : Diagnosis Procedure	105			
CHANGEOVER SWITCH : Component Inspection	106	SLIDING MOTOR	135	D
MIRROR SWITCH	107	Description	135	
MIRROR SWITCH : Description	107	Component Function Check	135	
MIRROR SWITCH : Component Function Check	107	Diagnosis Procedure	135	E
..	107	RECLINING MOTOR	137	
MIRROR SWITCH : Diagnosis Procedure	107	Description	137	
MIRROR SWITCH : Component Inspection	108	Component Function Check	137	F
POWER SEAT SWITCH GROUND CIRCUIT ..	110	Diagnosis Procedure	137	
Diagnosis Procedure	110	LIFTING MOTOR (FRONT)	139	G
TILT & TELESCOPIC SWITCH GROUND CIRCUIT	111	Description	139	
Diagnosis Procedure	111	Component Function Check	139	
SLIDING SENSOR	112	Diagnosis Procedure	139	H
Description	112	LIFTING MOTOR (REAR)	141	
Component Function Check	112	Description	141	
Diagnosis Procedure	112	Component Function Check	141	I
RECLINING SENSOR	115	Diagnosis Procedure	141	
Description	115	TILT MOTOR	143	
Component Function Check	115	Description	143	ADP
Diagnosis Procedure	115	Component Function Check	143	
LIFTING SENSOR (FRONT)	118	Diagnosis Procedure	143	
Description	118	TELESCOPIC MOTOR	145	K
Component Function Check	118	Description	145	
Diagnosis Procedure	118	Component Function Check	145	
LIFTING SENSOR (REAR)	121	Diagnosis Procedure	145	L
Description	121	DOOR MIRROR MOTOR	147	
Component Function Check	121	Description	147	
Diagnosis Procedure	121	Component Function Check	147	M
TILT SENSOR	124	Diagnosis Procedure	147	
Description	124	Component Inspection	151	
Component Function Check	124	SEAT MEMORY INDICATOR	152	N
Diagnosis Procedure	124	Description	152	
TELESCOPIC SENSOR	127	Component Function Check	152	
Description	127	Diagnosis Procedure	152	O
Component Function Check	127	Component Inspection	153	
Diagnosis Procedure	127	SYMPTOM DIAGNOSIS	154	P
MIRROR SENSOR	130	ADP SYSTEM SYMPTOMS	154	
		Symptom Table	154	
		NORMAL OPERATING CONDITION	155	
		Description	155	
		REMOVAL AND INSTALLATION	156	

DRIVER SEAT CONTROL UNIT	156	Removal and Installation	158
Removal and Installation	156		
AUTOMATIC DRIVE POSITIONER CON-		POWER SEAT SWITCH	159
TROL UNIT	157	Removal and Installation	159
Removal and Installation	157	ADP STEERING SWITCH	160
SEAT MEMORY SWITCH	158	Removal and Installation	160

PRECAUTIONS

< PRECAUTION >

PRECAUTION

PRECAUTIONS

Precaution for Supplemental Restraint System (SRS) "AIR BAG" and "SEAT BELT PRE-TENSIONER"

INFOID:000000008945489

The Supplemental Restraint System such as "AIR BAG" and "SEAT BELT PRE-TENSIONER", used along with a front seat belt, helps to reduce the risk or severity of injury to the driver and front passenger for certain types of collision. Information necessary to service the system safely is included in the SR and SB section of this Service Manual.

WARNING:

- To avoid rendering the SRS inoperative, which could increase the risk of personal injury or death in the event of a collision which would result in air bag inflation, all maintenance must be performed by an authorized NISSAN/INFINITI dealer.
- Improper maintenance, including incorrect removal and installation of the SRS, can lead to personal injury caused by unintentional activation of the system. For removal of Spiral Cable and Air Bag Module, see the SR section.
- Do not use electrical test equipment on any circuit related to the SRS unless instructed to in this Service Manual. SRS wiring harnesses can be identified by yellow and/or orange harnesses or harness connectors.

PRECAUTIONS WHEN USING POWER TOOLS (AIR OR ELECTRIC) AND HAMMERS

WARNING:

- When working near the Airbag Diagnosis Sensor Unit or other Airbag System sensors with the Ignition ON or engine running, DO NOT use air or electric power tools or strike near the sensor(s) with a hammer. Heavy vibration could activate the sensor(s) and deploy the air bag(s), possibly causing serious injury.
- When using air or electric power tools or hammers, always switch the Ignition OFF, disconnect the battery and wait at least 3 minutes before performing any service.

Precaution for Work

INFOID:000000008945490

ADP

- When removing or disassembling each component, be careful not to damage or deform it. If a component may be subject to interference, be sure to protect it with a shop cloth.
- When removing (disengaging) components with a screwdriver or similar tool, be sure to wrap the component with a shop cloth or vinyl tape to protect it.
- Protect the removed parts with a shop cloth and prevent them from being dropped.
- Replace a deformed or damaged clip.
- If a part is specified as a non-reusable part, always replace it with a new one.
- Be sure to tighten bolts and nuts securely to the specified torque.
- After installation is complete, be sure to check that each part works properly.
- Follow the steps below to clean components:
 - Water soluble dirt:
 - Dip a soft cloth into lukewarm water, wring the water out of the cloth and wipe the dirty area.
 - Then rub with a soft, dry cloth.
 - Oily dirt:
 - Dip a soft cloth into lukewarm water with mild detergent (concentration: within 2 to 3%) and wipe the dirty area.
 - Then dip a cloth into fresh water, wring the water out of the cloth and wipe the detergent off.
 - Then rub with a soft, dry cloth.
 - Do not use organic solvent such as thinner, benzene, alcohol or gasoline.
 - For genuine leather seats, use a genuine leather seat cleaner.

PREPARATION

< PREPARATION >

PREPARATION

PREPARATION

Special Service Tool

INFOID:000000008508668

The actual shapes of Kent-Moore tools may differ from those of special service tools illustrated here.

Tool number (Kent-Moore No.) Tool name	Description
— (J-46534) Trim tool set	Removing trim components

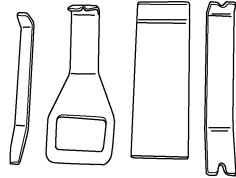

AWJIA0483ZZ

COMPONENT PARTS

< SYSTEM DESCRIPTION >

SYSTEM DESCRIPTION

COMPONENT PARTS

Component Parts Location

INFOID:000000008508669

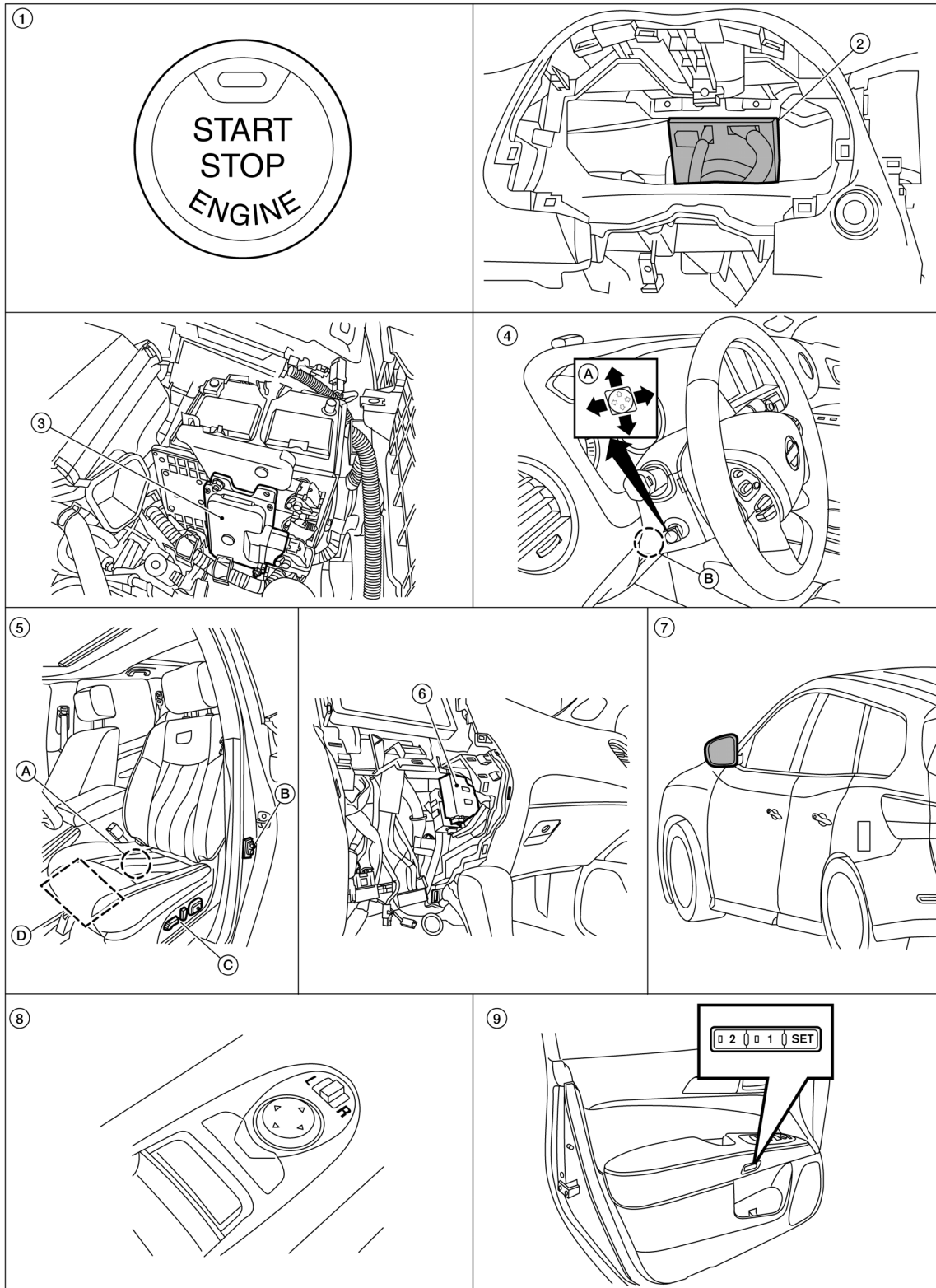

A
B
C
D
E
F
G
H
I
ADP
K
L
M
N
O
P

COMPONENT PARTS

< SYSTEM DESCRIPTION >

- | | | |
|--|---|--|
| 1. Push-button ignition switch | 2. BCM (view with instrument panel re-
moved) | 3. TCM |
| 4. A. ADP steering switch
B. Tilt motor, telescopic motor | 5. A. Driver seat control unit
B. Front door switch LH
C. Power seat switch LH
D. Sliding motor LH, reclining motor
LH, lifting motor LH (front/rear) | 6. Automatic drive positioner control
unit (view with AV control unit re-
moved) |
| 7. Door mirror LH (RH similar) | 8. Power mirror remote control switch | 9. Seat memory switch |

Component Description

INFOID:000000008508670

Component parts	Description
Driver seat control unit	<ul style="list-style-type: none"> • Main units of automatic drive positioner system. • It is connected to the CAN. • It communicates with automatic drive positioner control unit via UART communication. • It performs memory function after receiving the door unlock signal from BCM. • Operates each motor of seat to the registered position. • Requests the operation of steering column and door mirror to automatic drive positioner control unit • Operates the specific seat motor with the signal from power seat switch. • Transmits the ignition switch signal (ACC/ON) via UART communication to automatic driver positioner control unit.
Automatic drive positioner control unit	<ul style="list-style-type: none"> • It communicates with driver seat control unit via UART communication. • Performs various controls with the instructions of driver seat control unit. • Performs the controls of tilt & telescopic, door mirror and seat memory switch. • Operates steering column and door mirror with the signal from the driver seat control unit
BCM	<p>Recognizes the following status and transmits it to driver seat control unit via CAN communication.</p> <ul style="list-style-type: none"> • Handle position: LHD • Driver door: OPEN/CLOSE • Ignition switch position: ACC/ON • Door lock: UNLOCK (with Intelligent Key or driver side door request switch operation) • Key ID • Starter: CRANKING/OTHER
TCM	<p>The following signals are transmitted to driver seat control unit via CAN communication.</p> <ul style="list-style-type: none"> • Shift position signal (P range) • Identification of transmission: CVT
Combination meter	<p>Transmits the vehicle speed signal to driver seat control unit via CAN communication.</p>
CVT shift selector (Detention switch)	<ul style="list-style-type: none"> • Detention switch is installed on CVT shift selector. It is turned OFF when CVT shift selector is in P position. • Driver seat control unit judges that CVT shift selector is in P position if continuity does not exist in this circuit.

COMPONENT PARTS

< SYSTEM DESCRIPTION >

Component parts		Description
Power mirror remote control switch	Mirror switch	<ul style="list-style-type: none"> Mirror switch is integrated in power mirror remote control switch. It operates angle of door mirror face. It transmits mirror face adjust operation to automatic drive positioner control unit.
	Changeover switch	<ul style="list-style-type: none"> Changeover switch is integrated in power mirror remote control switch. Changeover switch has three positions (L, N and R). It changes operating door mirror motor by transmitting control signal to automatic drive positioner control unit.
ADP steering switch	Tilt switch	<ul style="list-style-type: none"> Tilt switch is equipped to steering column. The operation signal is input to automatic drive positioner control unit when tilt switch is operated.
	Telescopic switch	<ul style="list-style-type: none"> Telescopic switch is equipped to steering column. The operation signal is input to automatic drive positioner control unit when telescopic switch is operated.
Seat memory switch	Set switch	It is used for registration and setting change of driving position and Intelligent Key interlock function.
	Seat memory switch	<ul style="list-style-type: none"> The maximum 2 driving positions can be registered by memory switch 1 to 2. Driving position is set to the registered driving position when memory switch is pressed while operation conditions are satisfied.
	Seat memory indicator	Memory indicator indicates the status of auto driving position system by turning ON or blinking.
Power seat switch	Sliding switch	<ul style="list-style-type: none"> Sliding switch is equipped to power seat switch on seat cushion side surface. The operation signal is input to driver seat control unit when sliding switch is operated.
	Reclining switch	<ul style="list-style-type: none"> The operation signal is input to driver seat control unit when reclining switch is operated. The operation signal is input to driver seat control unit when reclining switch is operated.
	Lifting switch (front)	<ul style="list-style-type: none"> Lifting switch (front) is equipped to power seat switch on seat cushion side surface. The operation signal is input to driver seat control unit when lifting switch (front) is operated.
	Lifting switch (rear)	<ul style="list-style-type: none"> Lifting switch (rear) is equipped to power seat switch on seat cushion side surface. The operation signal is input to driver seat control unit when lifting switch (rear) is operated.
Door mirror (driver side/ passenger side)	Door mirror motor	It makes mirror face operate from side to side and up and down with the electric power that automatic drive positioner control unit supplies.
	Mirror sensor	<ul style="list-style-type: none"> Mirror sensor is installed to door mirror. The resistance of 2 sensors (horizontal and vertical) is changed when door mirror is operated. Automatic drive positioner control unit calculates door mirror position according to the change of the voltage of 2 sensor input terminals.

A
B
C
D
E
F
G
H
I
ADP
K
L
M
N
O
P

COMPONENT PARTS

< SYSTEM DESCRIPTION >

Component parts		Description
Tilt motor	Tilt motor	<ul style="list-style-type: none"> • Tilt motor is installed to steering column assembly. • Tilt motor is activated with automatic drive positioner control unit. • Steering column is tilted upward/downward by changing the rotation direction of tilt motor.
	Tilt sensor	<ul style="list-style-type: none"> • Tilt sensor is integrated in tilt motor. • The resistance of tilt sensor is changed according to the up/down position of steering column. • The terminal voltage of automatic drive positioner control unit will be changed according to a change of tilt sensor resistance. • Automatic drive positioner control unit calculates the tilt position from the voltage.
Telescopic motor	Telescopic motor	<ul style="list-style-type: none"> • Telescopic motor is installed to steering column assembly. • Telescopic motor is activated with automatic drive positioner control unit. • Compresses steering column by changing the rotation direction of telescopic motor.
	Telescopic sensor	<ul style="list-style-type: none"> • Telescopic sensor is integrated in telescopic motor. • The resistance of telescopic sensor is changed according to the forward/backward position of steering column. • The terminal voltage of automatic drive positioner control unit will be changed according to a change of telescopic sensor resistance. • Automatic drive positioner control unit calculates the telescopic position from the voltage.
Sliding motor LH	Sliding motor LH	<ul style="list-style-type: none"> • Seat sliding motor LH is installed to the seat cushion frame. • Seat sliding motor LH is activated with driver seat control unit. • Slides the seat frontward/ rearward by changing the rotation direction of sliding motor.
	Sliding sensor	<ul style="list-style-type: none"> • Sliding sensor is integrated in sliding motor. • The pulse signal is input to driver seat control unit when sliding is performed. • Driver seat control unit counts the pulse and calculates the sliding amount of the seat.
Reclining motor LH	Reclining motor LH	<ul style="list-style-type: none"> • Seat reclining motor LH is installed to seat back frame. • Seat reclining motor LH is activated with driver seat control unit. • Seatback is reclined frontward/rearward by changing the rotation direction of reclining motor.
	Reclining sensor	<ul style="list-style-type: none"> • Reclining sensor is integrated in reclining motor. • The pulse signal is input to driver seat control unit when the reclining is operated. • Driver seat control unit counts the pulse and calculates the reclining amount of the seat.
Lifting motor LH (front)	Lifting motor LH (front)	<ul style="list-style-type: none"> • Lifting motor LH (front) is installed to seat side cushion frame. • Lifting motor LH (front) is activated with driver seat control unit. • Seat lifter (front) is moved upward/downward by changing the rotation direction of lifting motor (front).
	Lifting sensor (front)	<ul style="list-style-type: none"> • Lifting sensor (front) is installed in lifting motor (rear). • When lifting motor (rear) operates, pulse signal is transmitted to driver seat control unit from lifting sensor. Driver seat control unit counts the pulse and calculates the lift position (rear) of the seat.
Lifting motor LH (rear)	Lifting motor LH (rear)	<ul style="list-style-type: none"> • Lifting motor LH (rear) is installed to seat slide cushion frame. • Lifting motor LH (rear) is activated with driver seat control unit. • Seat lifter (rear) is moved upward/downward by changing the rotation direction of lifting motor (rear).
	Lifting sensor (rear)	<ul style="list-style-type: none"> • Lifting sensor (rear) is installed to seat side cushion frame. • The pulse signal is input to driver seat control unit when lifting (rear) is operated. • Driver seat control unit counts the pulse and calculates the lifting (rear) amount of the seat.

SYSTEM

< SYSTEM DESCRIPTION >

SYSTEM

AUTOMATIC DRIVE POSITIONER SYSTEM

AUTOMATIC DRIVE POSITIONER SYSTEM : System Diagram

INFOID:000000008901623

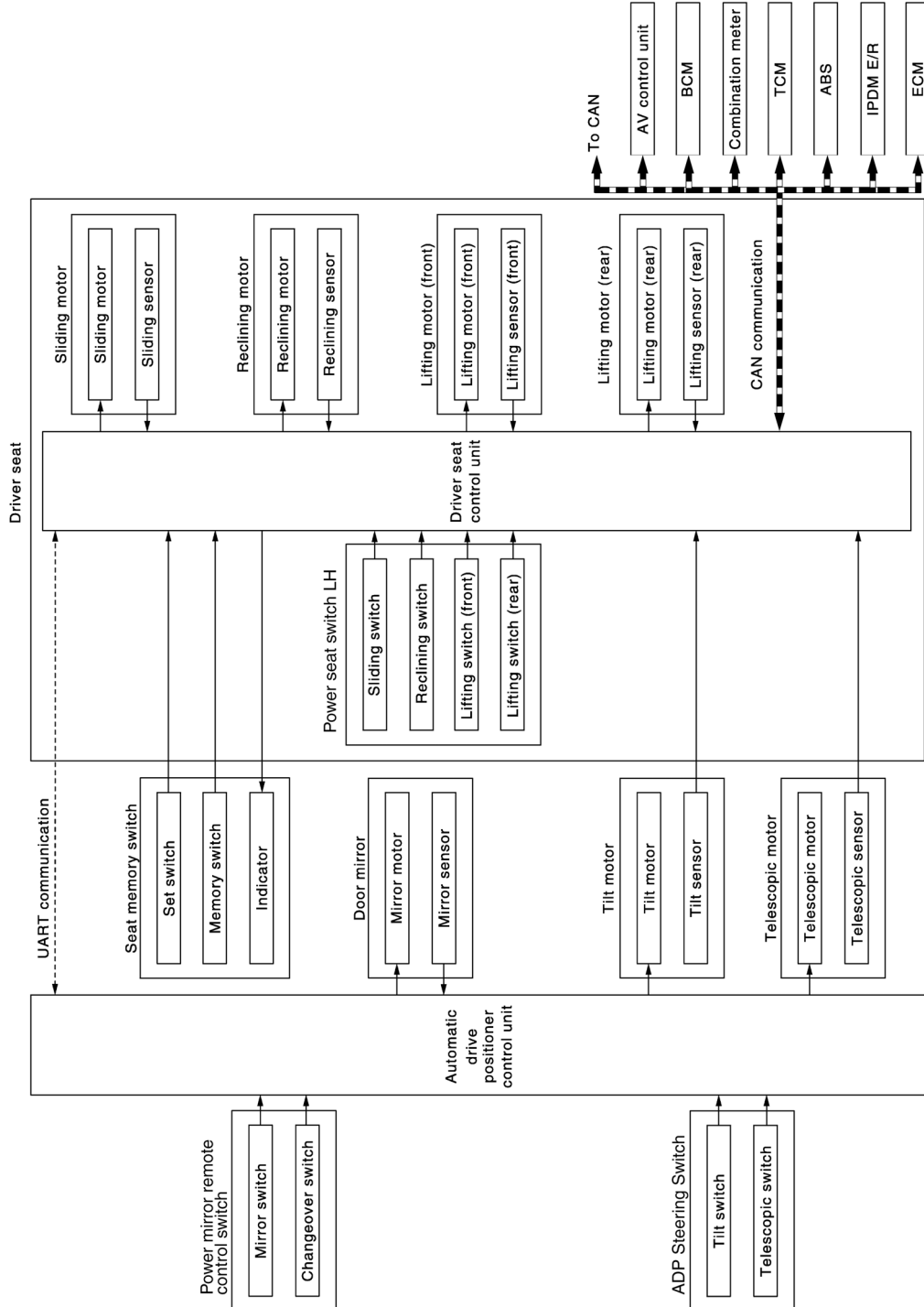

A
B
C
D
E
F
G
H
I
J
K
L
M
N
O
P

ADP

ALJIA0797GB

AUTOMATIC DRIVE POSITIONER SYSTEM : System Description

INFOID:000000008901624

OUTLINE

SYSTEM

< SYSTEM DESCRIPTION >

The system automatically moves the driver seat, steering column and door mirror position by the driver seat control unit and the automatic drive positioner control unit. The driver seat control unit corresponds with the automatic drive positioner control unit by UART communication.

Function		Description
Manual function		The driving position (seat, steering column and door mirror position) can be adjusted by using the power seat switch, ADP steering switch or door mirror remote control switch.
Memory function		The seat, steering column and door mirror move to the stored driving position by pressing seat memory switch (1 or 2).
Entry/Exit assist function	Exit	On exit, the seat moves backward and the steering column moves upward.
	Entry	On entry, the seat and steering column returns from exiting position to the previous driving position.
Intelligent Key interlock function		Perform memory operation, exiting operation and entry operation by Intelligent Key unlock operation or driver side door request switch unlock operation.

NOTE:

The lumbar support system is controlled independently with no link to the automatic drive positioner system.

MANUAL FUNCTION

SYSTEM

< SYSTEM DESCRIPTION >

MANUAL FUNCTION : System Diagram

INFOID:000000008901625

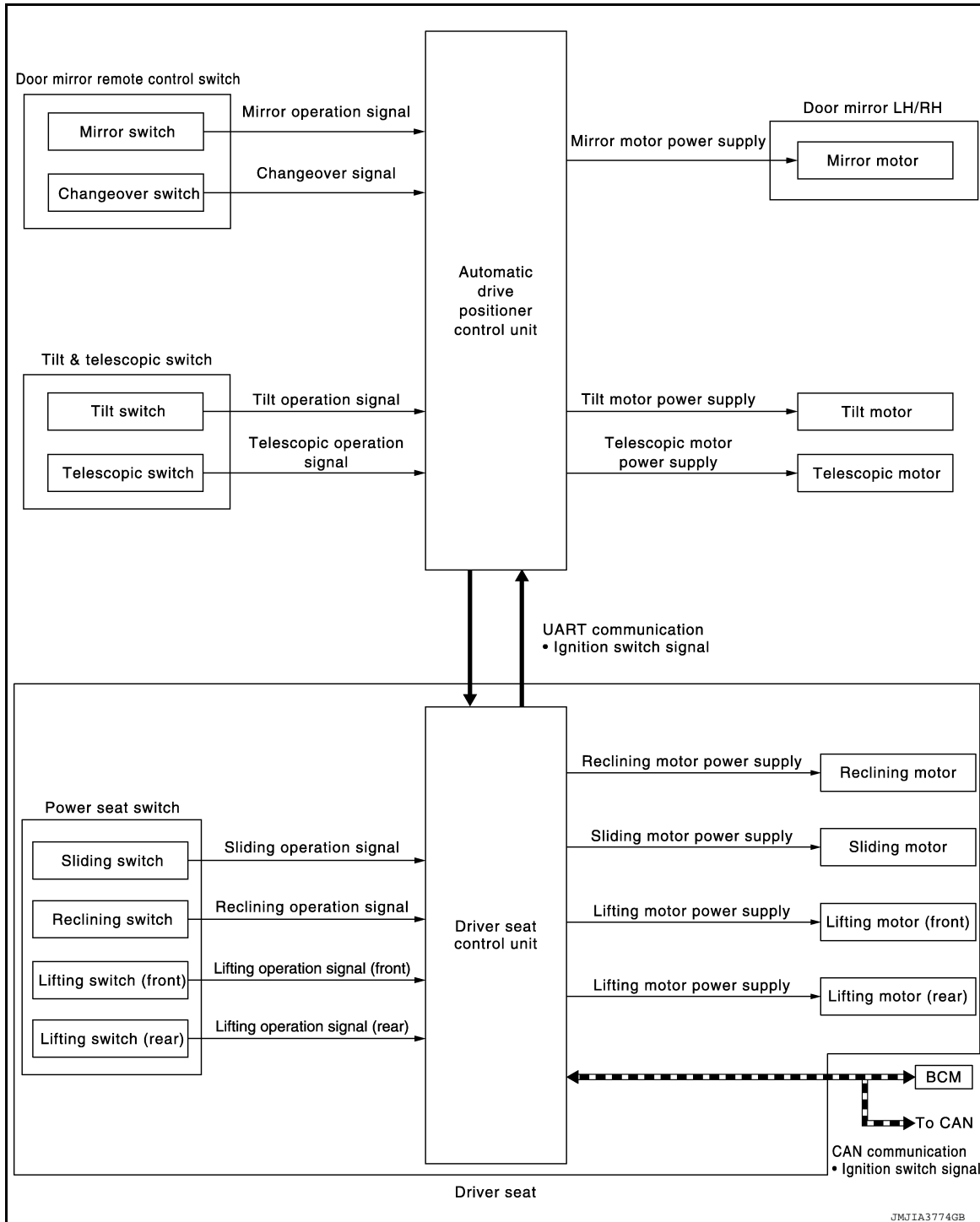

A
B
C
D
E
F
G
H
I
ADP
K
L
M
N
O
P

MANUAL FUNCTION : System Description

INFOID:000000008901626

OUTLINE

The driving position (seat, steering column and door mirror position) can be adjusted manually with power seat switch, ADP steering switch and door mirror remote control switch.

OPERATION PROCEDURE

1. Turn ignition switch ON.
2. Operate power seat switch, ADP steering switch or door mirror remote control switch.
3. The driver seat, steering column or door mirror operates according to the operation of each switch.

SYSTEM

< SYSTEM DESCRIPTION >

DETAIL FLOW

Seat

Order	Input	Output	Control unit condition
1	Power seat switch (sliding, lifting, reclining)	—	The power seat switch signal is inputted to the driver seat control unit when the power seat switch is operated.
2	—	Motors (sliding LH, lifting LH, reclining LH)	The driver seat control unit outputs signals to each motor according to the power seat switch input signal.

Tilt and Telescopic

Order	Input	Output	Control unit condition
1	ADP steering switch	—	The ADP steering switch signal is input to the automatic drive positioner control unit when the ADP steering switch is operated.
2	—	Motors (tilt, telescopic)	The automatic drive positioner control unit actuates the motors according to the operation of the ADP steering switch signal.
3	Sensors (tilt, telescopic)	—	The automatic drive positioner control unit recognizes any operation limit of each actuator via each sensor and will not operate the motors anymore at that time.

Door Mirror

Order	Input	Output	Control unit condition
1	Door mirror remote control switch	—	The door mirror remote control switch signal is inputted to the automatic drive positioner control unit when the door mirror remote control switch is operated.
2	—	Motors (Door mirror motor)	The automatic drive positioner control unit actuates each motor according to the operation of the door mirror remote control switch.

NOTE:

The door mirrors can be operated manually when ignition switch is in either ACC or ON position. The ignition switch signal (ACC/ON) is transmitted from BCM to the driver seat control unit via CAN communication and from the driver seat control unit to the automatic drive positioner control unit via UART communication.

MEMORY FUNCTION

SYSTEM

< SYSTEM DESCRIPTION >

MEMORY FUNCTION : System Diagram

INFOID:000000008901627

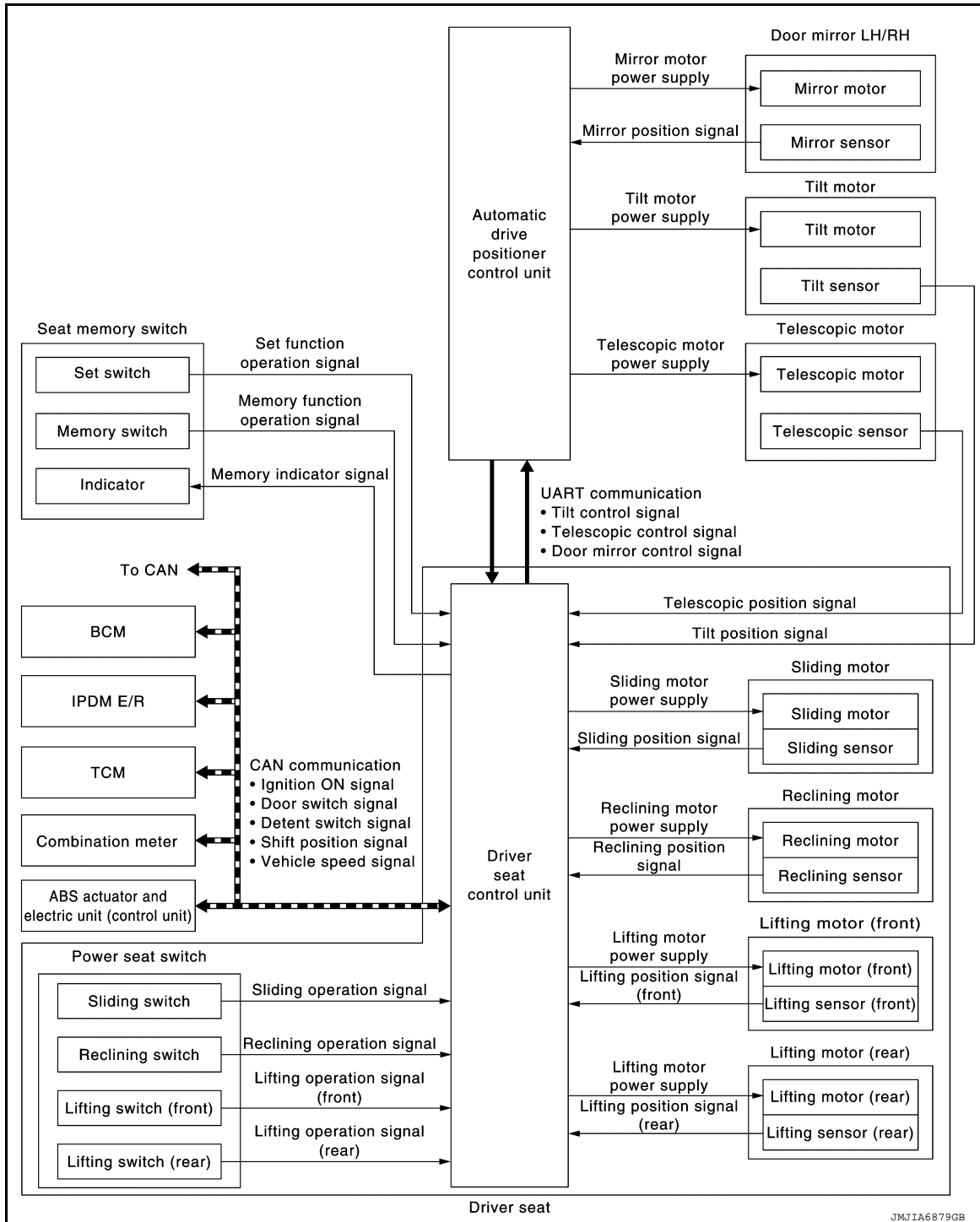

A
B
C
D
E
F
G
H
I
ADP
K
L
M
N
O
P

MEMORY FUNCTION : System Description

INFOID:000000008901628

OUTLINE

The driver seat control unit can store the optimum driving positions (seat, steering column and door mirror position) for 2 people. If the front seat position is changed, one-touch (pressing desired memory switch) operation allows changing to the other driving position.

NOTE:

For further information for the memory storage procedure, refer to Owner's Manual.

OPERATION PROCEDURE

1. Turn ignition switch ON.

SYSTEM

< SYSTEM DESCRIPTION >

2. Press desired memory switch.
3. Front seat LH, steering column and door mirror will move to the memorized position.

OPERATION CONDITION

Satisfy all of the following items. The memory function is not performed if these items are not satisfied.

Item	Request status
Ignition position	ON
Switch inputs <ul style="list-style-type: none"> • Power seat switch • ADP steering switch • Door mirror control switch • Set switch • Seat memory switch 	OFF (Not operated)
CVT selector lever	P position

However, the memory operation can be performed for 45 seconds after opening the front door LH (front door switch LH OFF → ON) even if the ignition switch is OFF.

DETAIL FLOW

Order	Input	Output	Control unit condition
1	Memory switch	—	The memory switch signal is inputted to the automatic drive positioner control unit when memory switch 1 or 2 is operated. Memory switch signal is input to driver seat control unit via UART communication.
2	—	Motors (seat, steering, door mirror)	Driver seat control unit operates each motor of seat when it recognizes the memory switch pressed and requests each motor operation to automatic drive positioner control unit via UART communication. The automatic drive positioner control unit operates each motor.
2	—	Memory switch indicator	Driver seat control unit requests the flashing of memory indicator to automatic drive positioner control unit via UART communication while either of the motors is operating. The automatic drive positioner control unit illuminates the memory indicator.
3	Sensors (seat, steering column, door mirrors)	—	Driver seat control unit judges the operating seat position with each seat sensor input. The positions of the steering column and outside mirrors are monitored with each sensor signal that is input from auto drive positioner control unit via UART communication. Driver seat control unit stops the operation of each motor when each part reaches the recorded address.
4	—	Memory switch indicator	Driver seat control unit requests the illumination of memory indicator to auto drive positioner control unit via UART communication after all motors stop. The auto driving positioner control unit illuminates the memory indicator for 5 seconds.

EXIT ASSIST FUNCTION

SYSTEM

< SYSTEM DESCRIPTION >

EXIT ASSIST FUNCTION : System Diagram

INFOID:000000008901629

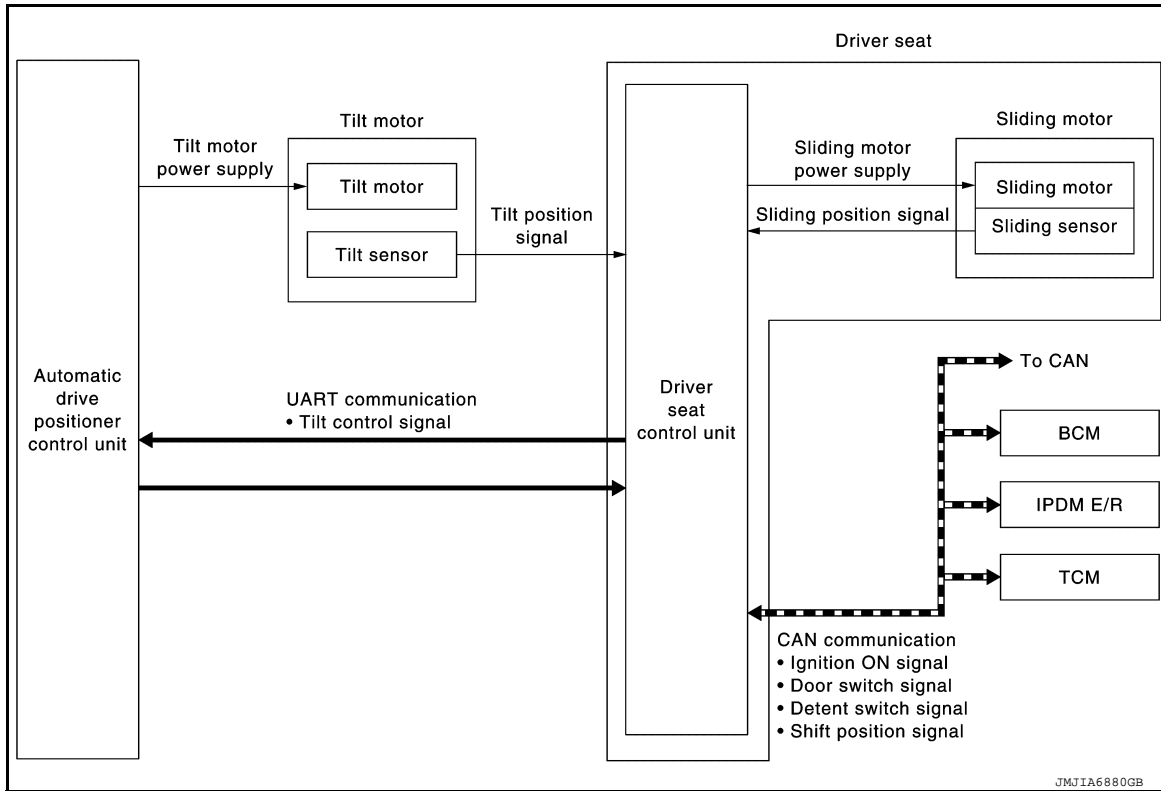

A
B
C
D
E
F
G
H

EXIT ASSIST FUNCTION : System Description

INFOID:000000008901630

OUTLINE

When exiting, if the conditions are satisfied, the seat is moved backward from normal sitting position and the steering column is moved up.

The seat slide amount at entry/exit operation can be changed.

NOTE:

- This function is set to ON before delivery (initial setting).
- For further information for the system setting procedure, refer to Owner's Manual.

OPERATION PROCEDURE

1. Open the front door LH with ignition switch in OFF position.
2. Front seat LH and steering column will move to the exiting position.

OPERATION CONDITION

Satisfy all of the following items. The exit assist function is not performed if these items are not satisfied.

Item	Request status
Ignition switch	OFF
System setting [Entry/exit assist function]	ON
Initialization	Done
Switch inputs <ul style="list-style-type: none"> • Power seat switch • ADP steering switch • Door mirror remote control switch • Set switch • Seat memory switch 	OFF (Not operated)
CVT selector lever	P position

ADP

K

L

M

N

O

P

DETAIL FLOW

SYSTEM

< SYSTEM DESCRIPTION >

Order	Input	Output	Control unit condition
1	Front door switch LH	—	Driver seat control unit receives front door switch LH signal (open) from BCM via CAN communication.
2	—	Motors (seat sliding LH, tilt)	Driver seat control unit operates the seat sliding motor LH, which recognizes that the driver side door is opened with ignition switch OFF. Driver seat control unit then requests the operations of tilt motor to auto drive positioner control unit via UART communication. The automatic drive positioner control unit operates each motor for a constant amount.

ENTRY ASSIST FUNCTION

ENTRY ASSIST FUNCTION : System Diagram

INFOID:000000008901631

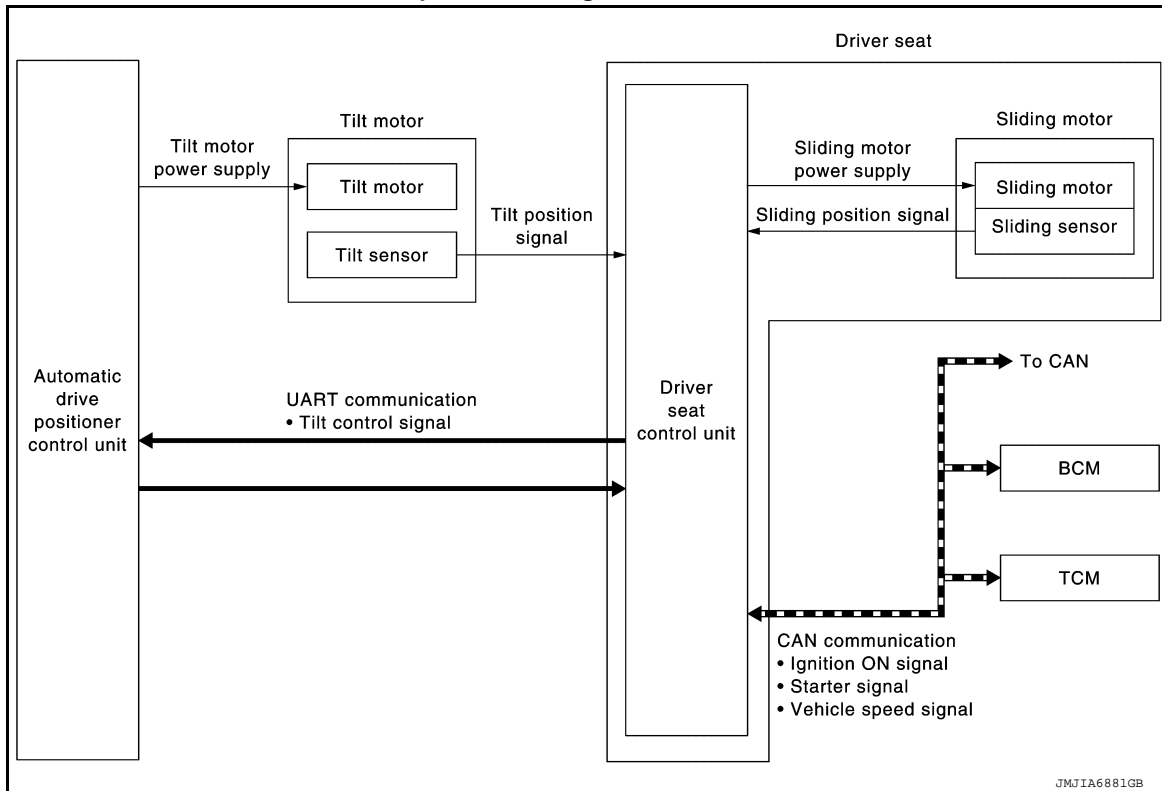

JMJIA6881GB

ENTRY ASSIST FUNCTION : System Description

INFOID:000000008901632

OUTLINE

The seat is in the exiting position when either following condition is satisfied, the seat returns from exiting position to the previous driving position.

NOTE:

- This function is set to OFF before delivery (initial setting).
- For further information for the system setting procedure, refer to Owner's Manual.

OPERATION PROCEDURE

1. Turn the ignition switch to ACC.
2. Front seat LH and steering column will return from the exiting position to entry position.

OPERATION CONDITION

Satisfy all of the following items. The entry assist function is not performed if these items are not satisfied.

SYSTEM

< SYSTEM DESCRIPTION >

Item	Request status
Seat, steering column	The vehicle is not moved after performing the exit assist function.
Switch inputs <ul style="list-style-type: none"> • Power seat switch • ADP steering switch • Door mirror control switch • Set switch • Memory switch 	OFF (Not operated)
CVT selector lever	P position

DETAIL FLOW

Order	Input	Output	Control unit condition
1	Door switch/Ignition switch	—	Driver seat control unit receives the signals of ignition switch signal and front door switch from BCM via CAN communication.
2	—	Motors (sliding LH, tilt)	Driver seat control unit operates the sliding motor LH when the operating conditions are satisfied and requests the operation of tilt motor to automatic drive positioner control unit via UART communication. The automatic drive positioner control unit operates the tilt motor.
	Sensors (sliding, tilt)	—	Each sensor monitors the operating positions of seat and steering column, then stops the operation of motor when each part reaches the recorded address.

INTELLIGENT KEY INTERLOCK FUNCTION

INTELLIGENT KEY INTERLOCK FUNCTION : System Diagram

INFOID:000000008901633

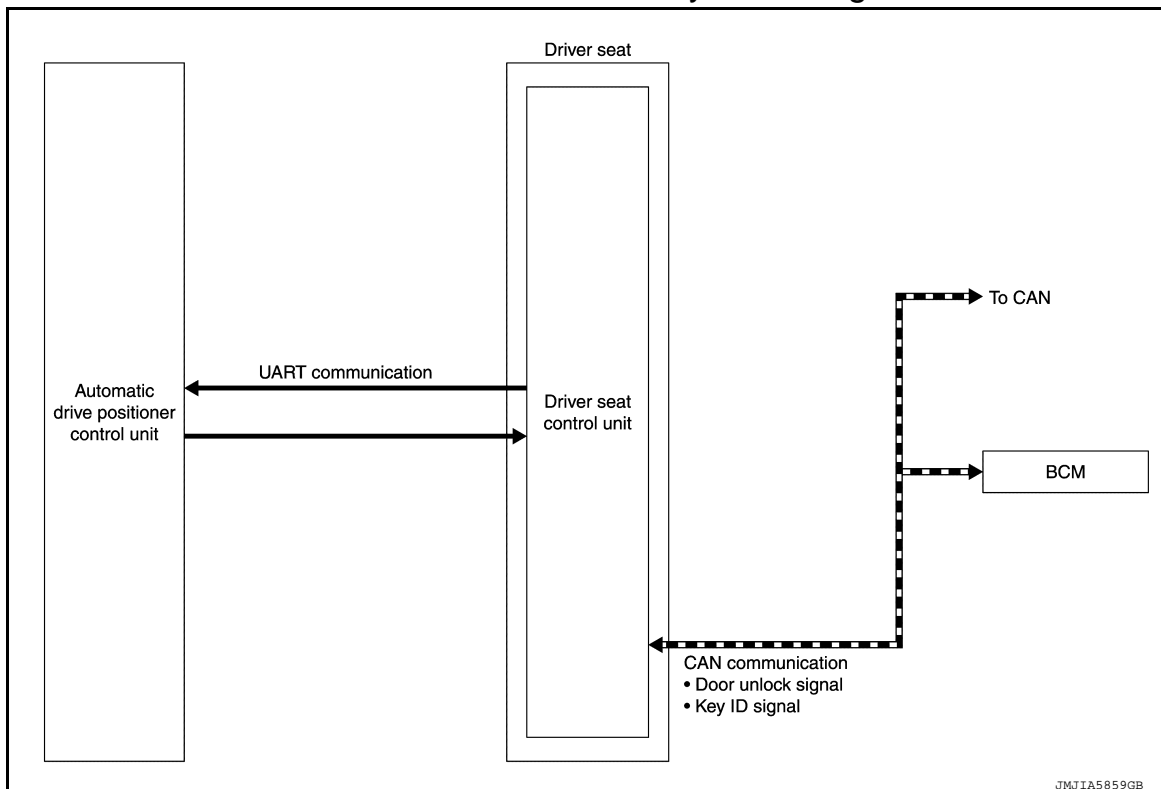

INTELLIGENT KEY INTERLOCK FUNCTION : System Description

INFOID:000000008901634

- By associating Intelligent Key and automatic drive positioner system, the unlock operation of Intelligent Key or driver side door request switch performs memory function and entry/exit assist function.

SYSTEM

< SYSTEM DESCRIPTION >

- Registration of Intelligent Key interlock function can register a different key ID to the driver seat control unit, one by one, for memory switch 1 and 2. A total of 2 key IDs can be registered.
- When ignition switch is OFF, and door unlock operation is performed using Intelligent Key or driver side door request switch, driver seat automatically adjusts to a driving position other than seat sliding. Seat sliding and steering column tilt perform return operation and are set to standby status.
- In standby status, when ignition switch is operated from OFF to ACC, return operation sets seat sliding and steering column tilt to a registered position.

NOTE:

- When another key ID is newly registered to a key switch to which a key ID is already registered, the previously registered key ID is overwritten and becomes unusable.
- When starter signal turns ON during return operation, the operation is interrupted, starter signal turns from ON to OFF, and operation restarts.

OPERATION PROCEDURE

1. Unlock driver door by Intelligent Key or driver side door request switch.
2. Operation other than memory function of seat sliding is performed. Seat sliding and steering column tilt perform exit assist operation.
3. Turn ignition switch ACC.
4. Driver seat and steering column will return from the exiting position to entry position.

NOTE:

Further information for Intelligent Key interlock function. Refer to [ADP-69, "INTELLIGENT KEY INTERLOCK STORING : Description"](#).

OPERATION CONDITION

Satisfy all of the following items. The Intelligent Key interlock function is not performed if these items are not satisfied.

Item	Request status
Ignition position	OFF
Intelligent Key interlock function	Registered
Switch inputs <ul style="list-style-type: none"> • Power seat switch • Tilt & telescopic switch • Door mirror control switch • Set switch • Memory switch 	OFF (Not operated)
CVT shift selector	P position

DETAIL FLOW

Order	Input	Output	Control unit condition
1	<ul style="list-style-type: none"> • Door unlock signal (CAN) • Key ID signal (CAN) 	—	Driver seat control unit receives the door unlock signal and the key ID signal from BCM when unlocking the door with Intelligent Key or driver side door request switch.
2	—	—	Driver seat control unit performs the seat slide and steering tilt move directly to the exit assist function. Other loads move to the exit assist function after performing memory function.
3	—	—	Driver seat control unit performs the entry assist function.

Fail Safe

INFOID:000000008901635

The fail-safe mode may be activated if the following symptoms are observed.

Operating in fail-safe mode	Malfunction Item	Related DTC	Diagnosis
Only manual functions operate normally.	CAN communication	U1000	ADP-72
	CONTROL UNIT	U1010	ADP-73
	EEPROM	B2130	ADP-82

SYSTEM

< SYSTEM DESCRIPTION >

Operating in fail-safe mode	Malfunction Item	Related DTC	Diagnosis
Only manual functions, except door mirror, operate normally.	UART communication	B2128	ADP-80
Only manual functions, except seat sliding, operate normally.	Seat sliding output	B2112	ADP-74
Only manual functions, except seat reclining, operate normally.	Seat reclining output	B2113	ADP-76
Only manual functions, except steering tilt, operate normally.	Steering column tilt output	B2116	ADP-78

A

B

C

D

E

F

G

H

I

ADP

K

L

M

N

O

P

DIAGNOSIS SYSTEM (DRIVER SEAT CONTROL UNIT)

< SYSTEM DESCRIPTION >

DIAGNOSIS SYSTEM (DRIVER SEAT CONTROL UNIT)

CONSULT Function

INFOID:000000008901636

The auto drive positioner system can be checked and diagnosed for component operation with CONSULT.

APPLICATION ITEMS

Diagnostic mode	Description
ECU Identification	Displays part numbers of driver seat control unit parts.
Self Diagnostic Result	Performs self-diagnosis for the auto drive positioner system and displays the results.
Active Test	Drive each output device.
Data Monitor	Displays input signals transmitted from various switches and sensors to driver seat control unit in real time.
Work support	Changes the setting of each function.

SELF-DIAGNOSIS RESULTS

Refer to [ADP-31, "DTC Index"](#).

ACTIVE TEST

CAUTION:

When driving vehicle, do not perform active test.

Test item	Description
SEAT SLIDE	Activates/deactivates the sliding motor LH.
SEAT RECLINING	Activates/deactivates the reclining motor LH.
SEAT LIFTER FR	Activates/deactivates the lifting motor LH (front).
SEAT LIFTER RR	Activates/deactivates the lifting motor LH (rear).
TILT MOTOR	Activates/deactivates the tilt motor.
TELESCO MOTOR	Activates/deactivates the telescopic motor.
MIRROR MOTOR RH	Activates/deactivates the mirror motor (passenger side).
MIRROR MOTOR LH	Activates/deactivates the mirror motor (driver side).
MEMORY SW INDCTR	Turns ON/OFF the memory indicator.

DATA MONITOR

Monitor Item	Unit	Main Signals	Selection From Menu	Contents
DETENT SW	"ON/OFF"	×	×	The selector lever position "OFF (P position) / ON (other than P position)" judged from the detention switch signal.
P RANG SW CAN	"ON/OFF"	×	×	ON/OFF status judged from the P range switch signal.
STARTER SW	"ON/OFF"	×	×	Ignition key switch ON (START, ON) /OFF (ACC, OFF) status judged from the ignition switch signal.
R RANGE (CAN)	"ON/OFF"	×	×	ON/OFF status judged from the R range switch signal.
VEHICLE SPEED	—	×	×	Display the vehicle speed signal received from combination meter by numerical value [km/h].
DOOR SW-FL	"OPEN/CLOSED"	×	×	ON/OFF status judged from the door switch (front driver side) signal.
DOOR SW-FR	"OPEN/CLOSED"	×	×	ON/OFF status judged from the door switch (front passenger side) signal.
IGN ON SW	"ON/OFF"	×	×	ON/OFF status judged from the ignition switch signal.
ACC ON SW	"ON/OFF"	×	×	ON/OFF status judged from the ACC switch signal.
KEY ON SW	"ON/OFF"	×	×	ON/OFF status judged from the key on switch signal.

DIAGNOSIS SYSTEM (DRIVER SEAT CONTROL UNIT)

< SYSTEM DESCRIPTION >

Monitor Item	Unit	Main Signals	Selection From Menu	Contents
KYLS DR UNLK	"ON/OFF"	×	×	ON/OFF status judged from the driver side door unlock actuator output switch signal.
KEYLESS ID	—	×	×	Key ID status judged from the key ID signal.
VHCL SPEED (ABS)	"RCV"	×	×	Vehicle speed status judged from vehicle speed signal.
HANDLE	"RHD/LHD"	×	×	RHD/LHD status judged from handle position signal.
TRANSMISSION	"A/T"	×	×	CVT status judged from transmission.
SET SW	"ON/OFF"	×	×	ON/OFF status judged from the setting switch signal.
MEMORY SW1	"ON/OFF"	×	×	ON/OFF status judged from the seat memory switch 1 signal.
MEMORY SW2	"ON/OFF"	×	×	ON/OFF status judged from the seat memory switch 2 signal.
SLIDE SW-FR	"ON/OFF"	×	×	ON/OFF status judged from the sliding switch (forward) signal.
SLIDE SW-RR	"ON/OFF"	×	×	ON/OFF status judged from the sliding switch (backward) signal.
RECLN SW-FR	"ON/OFF"	×	×	ON/OFF status judged from the reclining switch (forward) signal.
RECLN SW-RR	"ON/OFF"	×	×	ON/OFF status judged from the reclining switch (backward) signal.
LIFT FR SW-UP	"ON/OFF"	×	×	ON/OFF status judged from the lifting switch front (up) signal.
LIFT FR SW-DN	"ON/OFF"	×	×	ON/OFF status judged from the lifting switch front (down) signal.
LIFT RR SW-UP	"ON/OFF"	×	×	ON/OFF status judged from the lifting switch rear (up) signal.
LIFT RR SW-DN	"ON/OFF"	×	×	ON/OFF status judged from the lifting switch rear (down) signal.
MIR CON SW-UP	"ON/OFF"	×	×	ON/OFF status judged from the mirror switch (up) signal.
MIR CON SW-DN	"ON/OFF"	×	×	ON/OFF status judged from the mirror switch (down) signal.
MIR CON SW-RH	"ON/OFF"	×	×	ON/OFF status judged from the door mirror remote control switch (passenger side) signal.
MIR CON SW-LH	"ON/OFF"	×	×	ON/OFF status judged from the door mirror remote control switch (driver side) signal.
MIR CHNG SW-R	"ON/OFF"	×	×	ON/OFF status judged from the door mirror remote control switch (switching to right) signal.
MIR CHNG SW-L	"ON/OFF"	×	×	ON/OFF status judged from the door mirror remote control switch (switching to left) signal.
TILT SW-UP	"ON/OFF"	×	×	ON/OFF status judged from the ADP steering switch (up) signal.
TILT SW-DOWN	"ON/OFF"	×	×	ON/OFF status judged from the ADP steering switch (down) signal.
TELESCO SW-FR	"ON/OFF"	×	×	ON/OFF status judged from the ADP steering switch (forward) signal.
TELESCO SW-RR	"ON/OFF"	×	×	ON/OFF status judged from the ADP steering switch (backward) signal.
SLIDE PULSE	—	—	×	Value (32768) when battery connections are standard. If it moves backward, the value increases. If it moves forward, the value decreases.

A
B
C
D
E
F
G
H
I
K
L
M
N
O
P

ADP

DIAGNOSIS SYSTEM (DRIVER SEAT CONTROL UNIT)

< SYSTEM DESCRIPTION >

Monitor Item	Unit	Main Signals	Selection From Menu	Contents
RECLN PULSE	—	—	×	Value (32768) when battery connections are standard. If it moves backward, the value increases. If it moves forward, the value decreases.
LIFT FR PULSE	—	—	×	Value (32768) when battery connections are standard. If it moves DOWN, the value increases. If it moves UP, the value decreases.
LIFT RR PULSE	—	—	×	Value (32768) when battery connections are standard. If it moves DOWN, the value increases. If it moves UP, the value decreases.
MIR/SEN RH U-D	“V”	—	×	Voltage input from door mirror sensor (passenger side) up/down is displayed.
MIR/SEN RH R-L	“V”	—	×	Voltage input from door mirror sensor (passenger side) left/right is displayed.
MIR/SEN LH U-D	“V”	—	×	Voltage input from door mirror sensor (driver side) up/down is displayed.
MIR/SEN LH R-L	“V”	—	×	Voltage input from door mirror sensor (driver side) left/right is displayed.
TILT PULSE	—	—	×	Value (32768) when battery connections are standard. If it moves DOWN, the value increases. If it moves UP, the value decreases.
TELESCO PULSE	—	—	×	Value (32768) when battery connections are standard. If it moves backward, the value increases. If it moves forward, the value decreases.

WORK SUPPORT

Work item	Content	Item
EXIT SEAT SLIDE SETTING	Entry/exit assist (seat) can be selected: ON (operated) – OFF (not operated)	ON
		OFF
EXIT TILT SETTING	Entry/exit assist (steering column) can be selected: ON (operated) – OFF (not operated)	ON
		OFF
SEAT SLIDE VOLUME SET	The amount of seat sliding for entry/exit assist can be selected from 3 items.	40 mm (1.6 in)
		80 mm (3.1 in)
		150 mm (6 in)

DRIVER SEAT CONTROL UNIT

< ECU DIAGNOSIS INFORMATION >

ECU DIAGNOSIS INFORMATION

DRIVER SEAT CONTROL UNIT

Reference Value

INFOID:000000008901484

VALUES ON THE DIAGNOSIS TOOL

CONSULT MONITOR ITEM

Monitor Item	Condition		Value/Status
DETENT SW	CVT selector lever	P position	OFF
		Other than above	ON
P RANG SW CAN	CVT selector lever	P position	ON
		Other than above	OFF
STARTER SW	Ignition position	Cranking	ON
		Other than above	OFF
R RANGE (CAN)	CVT selector lever	R position	ON
		Other than above	OFF
VEHICLE SPEED	The condition of vehicle speed is displayed		km/h
DOOR SW-FL	Driver door	Open	OPEN
		Close	CLOSED
DOOR SW-FR	Passenger door	Open	OPEN
		Close	CLOSED
IGN ON SW	Ignition switch	ON position	ON
		Other than above	OFF
ACC ON SW	Ignition switch	ACC or ON position	ON
		Other than above	OFF
KEY ON SW	Intelligent Key	Inserted in key slot	ON
		Not Inserted in key slot	OFF
KYL5 DR UNLK	Intelligent Key or driver side door request switch	ON	ON
		OFF	OFF
KEYLESS ID	UNLOCK button of Intelligent Key is pressed		1, 2, 3, 4 or 5
VHCL SPEED (ABS)	CAN signal from ABS	Received	ON
		Not received	OFF
HANDLE	Driving position		LHD
			RHD
TRANSMISSION	Transmission type		A/T
SET SW	Set switch	Push	ON
		Release	OFF
MEMORY SW1	Memory switch 1	Push	ON
		Release	OFF
MEMORY SW2	Memory switch 2	Push	ON
		Release	OFF
SLIDE SW-FR	Sliding switch (forward)	Operate	ON
		Release	OFF
SLIDE SW-RR	Sliding switch (backward)	Operate	ON
		Release	OFF

A
B
C
D
E
F
G
H
I
K
L
M
N
O
P

ADP

DRIVER SEAT CONTROL UNIT

< ECU DIAGNOSIS INFORMATION >

Monitor Item	Condition		Value/Status
RECLN SW-FR	Reclining switch (forward)	Operate	ON
		Release	OFF
RECLN SW-RR	Reclining switch (backward)	Operate	ON
		Release	OFF
LIFT FR SW-UP	Lifting switch front (up)	Operate	ON
		Release	OFF
LIFT FR SW-DN	Lifting switch front (down)	Operate	ON
		Release	OFF
LIFT RR SW-UP	Lifting switch rear (up)	Operate	ON
		Release	OFF
LIFT RR SW-DN	Lifting switch rear (down)	Operate	ON
		Release	OFF
MIR CON SW-UP	Mirror switch	Up	ON
		Other than above	OFF
MIR CON SW-DN	Mirror switch	Down	ON
		Other than above	OFF
MIR CON SW-RH	Mirror switch	Right	ON
		Other than above	OFF
MIR CON SW-LH	Mirror switch	Left	ON
		Other than above	OFF
MIR CHNG SW-R	Changeover switch	Right	ON
		Other than above	OFF
MIR CHNG SW-L	Changeover switch	Left	ON
		Other than above	OFF
TILT SW-UP	Tilt switch	Upward	ON
		Other than above	OFF
TILT SW-DOWN	Tilt switch	Downward	ON
		Other than above	OFF
TELESCO SW-FR	Telescopic switch	Forward	ON
		Other than above	OFF
TELESCO SW-RR	Telescopic switch	Backward	ON
		Other than above	OFF
SLIDE PULSE	Seat sliding	Forward	The numeral value decreases *
		Backward	The numeral value increases*
		Other than above	No change to numeral value*
RECLN PULSE	Seat reclining	Forward	The numeral value decreases*
		Backward	The numeral value increases *
		Other than above	No change to numeral value *
LIFT FR PULSE	Seat lifter (front)	Up	The numeral value decreases *
		Down	The numeral value increases *
		Other than above	No change to numeral value *

DRIVER SEAT CONTROL UNIT

< ECU DIAGNOSIS INFORMATION >

Monitor Item	Condition		Value/Status
LIFT RR PULSE	Seat lifter (rear)	Up	The numeral value decreases *
		Down	The numeral value increases *
		Other than above	No change to numeral value *
MIR/SEN RH U-D	Door mirror (passenger side)		Change between 3.4 (close to peak) 0.6 (close to valley)
MIR/SEN RH R-L	Door mirror (passenger side)		Change between 3.4 (close to left edge) 0.6 (close to right edge)
MIR/SEN LH U-D	Door mirror (driver side)		Change between 3.4 (close to peak) 0.6 (close to valley)
MIR/SEN LH R-L	Door mirror (driver side)		Change between 0.6 (close to left edge) 3.4 (close to right edge)
TILT PULSE	Tilt position	Upward	The numeral value decreases *
		Downward	The numeral value increases *
		Other than above	No change to numeral value *
TELESCO PULSE	Telescopic position	Forward	The numeral value decreases *
		Backward	The numeral value increases *
		Other than above	No change to numeral value *

*: The value at the position attained when the battery is connected is regarded as 32768.

TERMINAL LAYOUT

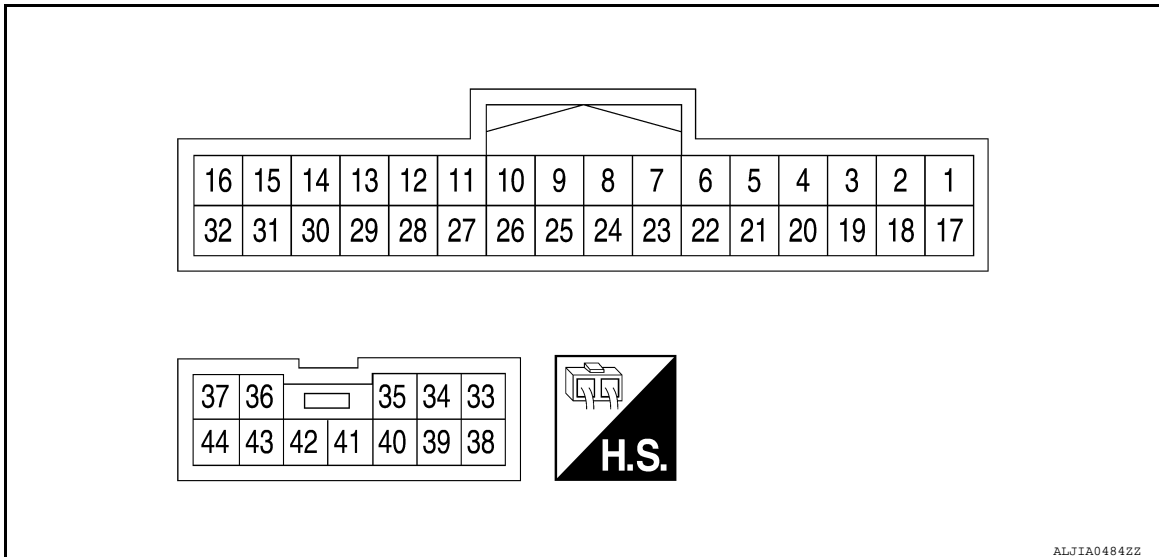

PHYSICAL VALUES

Terminal No. (wire color)		Description		Condition		Voltage (V) (Approx)
+	-	Signal name	Input/ Output			
5 (W)	Ground	Sensor power supply	Output	—		Battery voltage
6 (R)	Ground	Lifting switch (rear) down signal	Input	Lifting switch (rear)	Operate (down)	0
					Release	Battery voltage

DRIVER SEAT CONTROL UNIT

< ECU DIAGNOSIS INFORMATION >

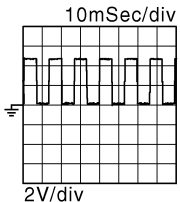
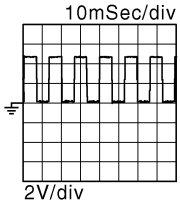
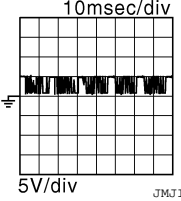
Terminal No. (wire color)		Description		Condition		Voltage (V) (Approx)
+	-	Signal name	Input/ Output			
7 (Y)	Ground	Lifting switch (front) down signal	Input	Lifting switch (front)	Operate (down)	0
					Release	Battery voltage
8 (BR)	Ground	Reclining switch backward signal	Input	Reclining switch	Operate (backward)	0
					Release	Battery voltage
9 (SB)	Ground	Sliding switch backward signal	Input	Sliding switch	Operate (backward)	0
					Release	Battery voltage
10 (G)	Ground	Memory indicator 2 signal	Output	Memory indicator 2	Illuminate	1
					Other than above	Battery voltage
11 (GR)	Ground	Memory switch 2 signal	Input	Memory switch 2	Press	0
					Other than above	5
12 (W)	Ground	Telescopic sensor signal	Input	Telescopic	Operate	 2V/div JMJA0119ZZ
					Other than above	0 or 5
13 (G)	Ground	Reclining sensor signal	Input	Seat reclining	Operate	 2V/div JMJA0119ZZ
					Stop	0 or 5
15 (SB)	Ground	UART communication (TX/RX)	Input	Ignition switch ON	 5V/div JMJA1391ZZ	
16 (P)	—	CAN-H	—	—	—	
21 (L)	Ground	Set switch signal	Input	Set switch	Press	0
					Other than above	5
22 (V)	Ground	Lifting switch (rear) up signal	Input	Seat lifting switch (rear)	Operate (up)	0
					Release	Battery voltage
23 (G)	Ground	Lifting switch (front) up signal	Input	Seat lifting switch (front)	Operate (up)	0
					Release	Battery voltage

DRIVER SEAT CONTROL UNIT

< ECU DIAGNOSIS INFORMATION >

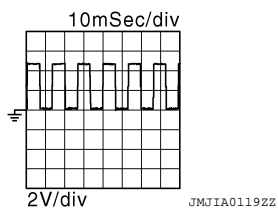
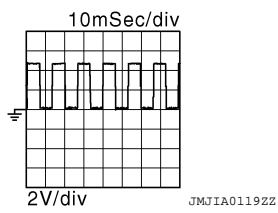
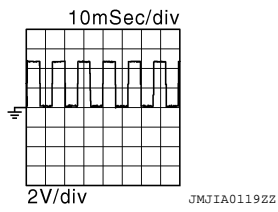
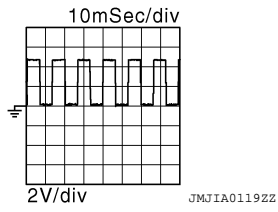
Terminal No. (wire color)		Description		Condition		Voltage (V) (Approx)
+	-	Signal name	Input/ Output			
24 (P)	Ground	Reclining switch forward signal	Input	Reclining switch	Operate (forward)	0
					Release	Battery voltage
25 (L)	Ground	Sliding switch forward signal	Input	Sliding switch	Operate (forward)	0
					Release	Battery voltage
26 (Y)	Ground	Memory indicator 1 signal	Output	Memory indicator 1	Illuminate	1
					Other than above	Battery voltage
27 (V)	Ground	Memory switch 1 signal	Input	Memory switch 1	Press	0
					Other than above	5
28 (BR)	Ground	Tilt sensor signal	Input	Tilt	Operate	
					Other than above	0 or 5
29 (R)	Ground	Lifting sensor (rear) signal	Input	Seat lifting (rear)	Operate	
					Stop	0 or 5
30 (Y)	Ground	Lifting sensor (front) signal	Input	Seat lifting (front)	Operate	
					Stop	0 or 5
31 (L)	Ground	Sliding sensor signal	Input	Seat sliding	Operate	
					Stop	0 or 5
32 (W)	—	CAN-L	—	—	—	—
34 (SB)	Ground	Lifting motor LH (front) down output signal	Output	Seat lifting (front)	Operate (down)	Battery voltage
					Stop	0

A
B
C
D
E
F
G
H
I
K
L
M
N
O
P

ADP

DRIVER SEAT CONTROL UNIT

< ECU DIAGNOSIS INFORMATION >

Terminal No. (wire color)		Description		Condition		Voltage (V) (Approx)
+	-	Signal name	Input/ Output			
35 (V)	Ground	Reclining motor LH forward output signal	Output	Seat reclining	Operate (forward)	Battery voltage
					Release	0
36 (W)	Ground	Sliding motor LH backward output signal	Output	Seat sliding	Operate (backward)	Battery voltage
					Stop	0
37 (R)	Ground	Power source	Input	—		Battery voltage
39 (B)	Ground	Ground (power)	—	—		0
40 (L)	Ground	Lifting motor LH (rear) down output signal	Output	Seat lifting (rear)	Operate (down)	Battery voltage
					Stop	0
41 (Y)	Ground	Lifting motor LH (rear) up output signal	Output	Seat lifting (rear)	Operate (up)	Battery voltage
					Stop	0
42 (GR)	Ground	Lifting motor LH (front) up output signal	Output	Seat lifting (front)	Operate (up)	Battery voltage
					Stop	0
43 (BR)	Ground	Reclining motor LH backward output signal	Output	Seat reclining	Operate (backward)	Battery voltage
					Stop	0
44 (G)	Ground	Sliding motor LH forward output signal	Output	Seat sliding	Operate (forward)	Battery voltage
					Release	0

Fail Safe

INFOID:000000008901485

The fail-safe mode may be activated if the following symptoms are observed.

Operating in fail-safe mode	Malfunction Item	Related DTC	Diagnosis
Only manual functions operate normally.	CAN communication	U1000	ADP-72
	CONTROL UNIT	U1010	ADP-73
	EEPROM	B2130	ADP-82
Only manual functions, except door mirror, operate normally.	UART communication	B2128	ADP-80
Only manual functions, except seat sliding, operate normally.	Seat sliding output	B2112	ADP-74
Only manual functions, except seat reclining, operate normally.	Seat reclining output	B2113	ADP-76
Only manual functions, except steering tilt, operate normally.	Steering column tilt output	B2116	ADP-78

DRIVER SEAT CONTROL UNIT

< ECU DIAGNOSIS INFORMATION >

DTC Index

INFOID:000000008901486

CONSULT display	Timing*1		Item	Reference page
	Current mal-function	Previous mal-function		
CAN COMM CIRCUIT [U1000]	0	1-39	CAN communication	ADP-72
CONTROL UNIT [U1010]	0	1-39	Control unit	ADP-73
SEAT SLIDE [B2112]	0	1-39	Seat slide motor output	ADP-74
SEAT RECLINING [B2113]	0	1-39	Seat reclining motor output	ADP-76
STEERING TILT [B2116]	0	1-39	Tilt motor output	ADP-78
UART COMM [B2128]	0	1-39	UART communication	ADP-80
EEPROM [B2130]	0	1-39	EEPROM	ADP-82

*1:

- 0: Current malfunction is present
- 1-39: Displayed if any previous malfunction is present when current condition is normal. The numeral value increases by one at each IGN ON to OFF cycle from 1 to 39. The counter remains at 39 even if the number of cycles exceeds it. However, the counter is reset to 1 if any malfunction is detected again, the normal operation is resumed and the ignition switch is turned from OFF to ON.

A
B
C
D
E
F
G
H
I
K
L
M
N
O
P

ADP

AUTOMATIC DRIVE POSITIONER CONTROL UNIT

< ECU DIAGNOSIS INFORMATION >

AUTOMATIC DRIVE POSITIONER CONTROL UNIT

Reference Value

INFOID:000000008901487

TERMINAL LAYOUT

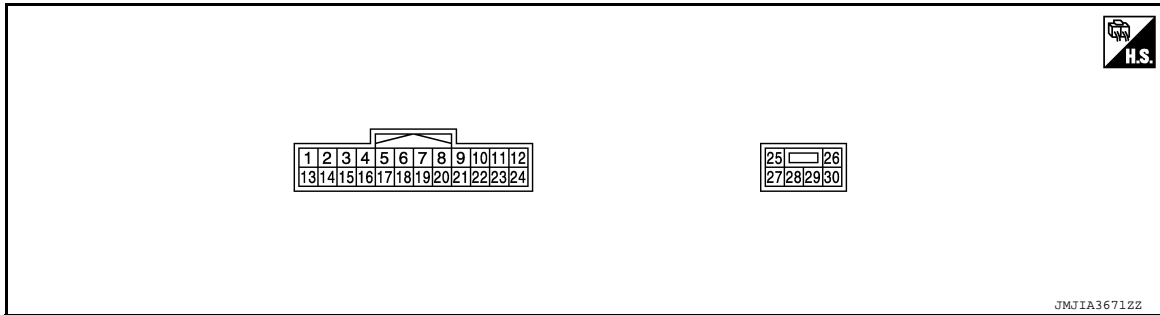

PHYSICAL VALUES

Terminal No. (wire color)		Description		Condition		Voltage (V) (Approx.)
+	-	Signal name	Input/ Output			
1 (LG)	Ground	Tilt switch up signal	Input	Tilt switch	Operate (up)	0
					Other than above	5
2 (GR)	Ground	Changeover switch RH signal	Input	Changeover switch position	RH	0
					Neutral or LH	5
3 (G)	Ground	Mirror switch up signal	Input	Mirror switch	Operated (up)	0
					Other than above	5
4 (P)	Ground	Mirror switch left signal	Input	Mirror switch	Operated (left)	0
					Other than above	5
5 (W)	Ground	Door mirror sensor (passenger side) up/down signal	Input	Door mirror RH position		Change between 3.4 (close to peak) 0.6 (close to valley)
6 (R)	Ground	Door mirror sensor (driver side) up/down signal	Input	Door mirror LH position		Change between 3.4 (close to peak) 0.6 (close to valley)
7 (BR)	Ground	Telescopic switch forward signal	Input	Telescopic switch	Operate (forward)	0
					Other than above	5
8 (G)	Ground	UART communication (TX/RX)	Output	Ignition switch ON		<p style="text-align: right;">JMJIA1391ZZ</p>

AUTOMATIC DRIVE POSITIONER CONTROL UNIT

< ECU DIAGNOSIS INFORMATION >

Terminal No. (wire color)		Description		Condition		Voltage (V) (Approx.)
+	-	Signal name	Input/ Output			
10 (BR)	Ground	Door mirror motor (passenger side) up output signal	Output	Door mirror RH	Operate (up)	Battery voltage
					Other than above	0
11 (G)	Ground	Door mirror motor (passenger side) left output signal	Output	Door mirror RH	Operate (left)	Battery voltage
					Other than above	0
12 (BG)	Ground	Door mirror motor (driver side) down output signal	Output	Door mirror (LH)	Operate (down)	Battery voltage
					Other than above	0
		Door mirror motor (driver side) right output signal			Operate (right)	Battery voltage
					Other than above	0
13 (Y)	Ground	Tilt switch down signal	Input	Tilt switch	Operate (down)	0
					Other than above	5
14 (P)	Ground	Changeover switch LH signal	Input	Changeover switch position	LH	0
					Neutral or RH	5
15 (R)	Ground	Mirror switch down signal	Input	Mirror switch	Operate (down)	0
					Other than above	5
16 (W)	Ground	Mirror switch right signal	Input	Mirror switch	Operate (right)	0
					Other than above	5
17 (G)	Ground	Door mirror sensor (passenger side) left/right signal	Input	Door mirror RH position		Change between 3.4 (close to left edge) 0.6 (close to right edge)
18 (BG)	Ground	Door mirror sensor (driver side) left/right signal	Input	Door mirror LH position		Change between 0.6 (close to left edge) 3.4 (close to right edge)
19 (L)	Ground	Telescopic switch backward signal	Input	Telescopic switch	Operate (backward)	0
					Other than above	5
20 (Y)	Ground	Ground	—	—		0
21 (BG)	Ground	Door mirror motor sensor power supply	Input	—		5

A
B
C
D
E
F
G
H
I
ADP
K
L
M
N
O
P

AUTOMATIC DRIVE POSITIONER CONTROL UNIT

< ECU DIAGNOSIS INFORMATION >

Terminal No. (wire color)		Description		Condition	Voltage (V) (Approx.)	
+	-	Signal name	Input/ Output			
22 (SB)	Ground	Door mirror motor (passenger side) down output signal	Output	Door mirror (RH)	Operate (down)	Battery voltage
					Other than above	0
		Door mirror motor (passenger side) right output signal			Operate (right)	Battery voltage
					Other than above	0
23 (LG)	Ground	Door mirror motor (driver side) up output signal	Output	Door mirror (LH)	Operate (up)	Battery voltage
					Other than above	0
24 (L)	Ground	Door mirror motor (driver side) left output signal	Output	Door mirror (LH)	Operate (left)	Battery voltage
					Other than above	0
25 (L)	Ground	Power source	Input	—	Battery voltage	
26 (V)	Ground	Telescopic motor backward output signal	Output	Steering telescopic	Operate (backward)	Battery voltage
					Other than above	0
27 (LG)	Ground	Tilt and telescopic motor power source		—	Battery voltage	
28 (SB)	Ground	Tilt motor down output signal	Output	Steering tilt	Operate (down)	Battery voltage
					Other than above	0
29 (BR)	Ground	Tilt motor up output signal	Output	Steering tilt	Operate (up)	Battery voltage
					Other than above	0
		Telescopic motor forward output signal		Steering telescopic	Operate (forward)	Battery voltage
					Other than above	0
30 (B)	Ground	Ground	—	—	0	

BCM (BODY CONTROL MODULE)

< ECU DIAGNOSIS INFORMATION >

BCM (BODY CONTROL MODULE)

List of ECU Reference

INFOID:000000008901488

ECU	Reference
BCM	BCS-28. "Reference Value"
	BCS-48. "Fail Safe"
	BCS-48. "DTC Inspection Priority Chart"
	BCS-50. "DTC Index"

A
B
C
D
E
F
G
H
I
K
L
M
N
O
P

ADP

AUTOMATIC DRIVE POSITIONER SYSTEM

< WIRING DIAGRAM >

WIRING DIAGRAM

AUTOMATIC DRIVE POSITIONER SYSTEM
WITHOUT AROUND VIEW MONITOR

WITHOUT AROUND VIEW MONITOR : Wiring Diagram

INFOID:000000008945716

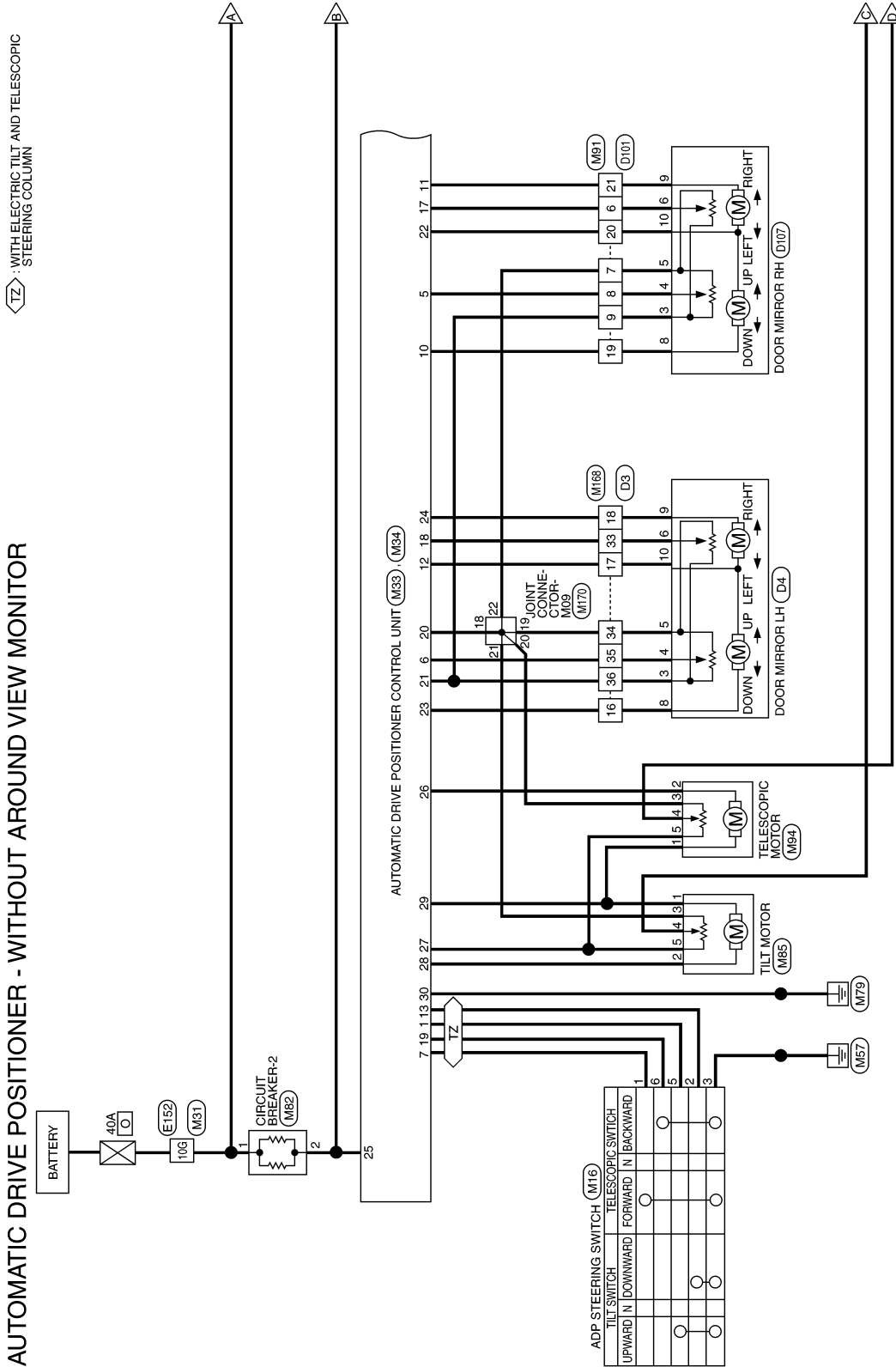

AAJWA0107GB

AUTOMATIC DRIVE POSITIONER SYSTEM

< WIRING DIAGRAM >

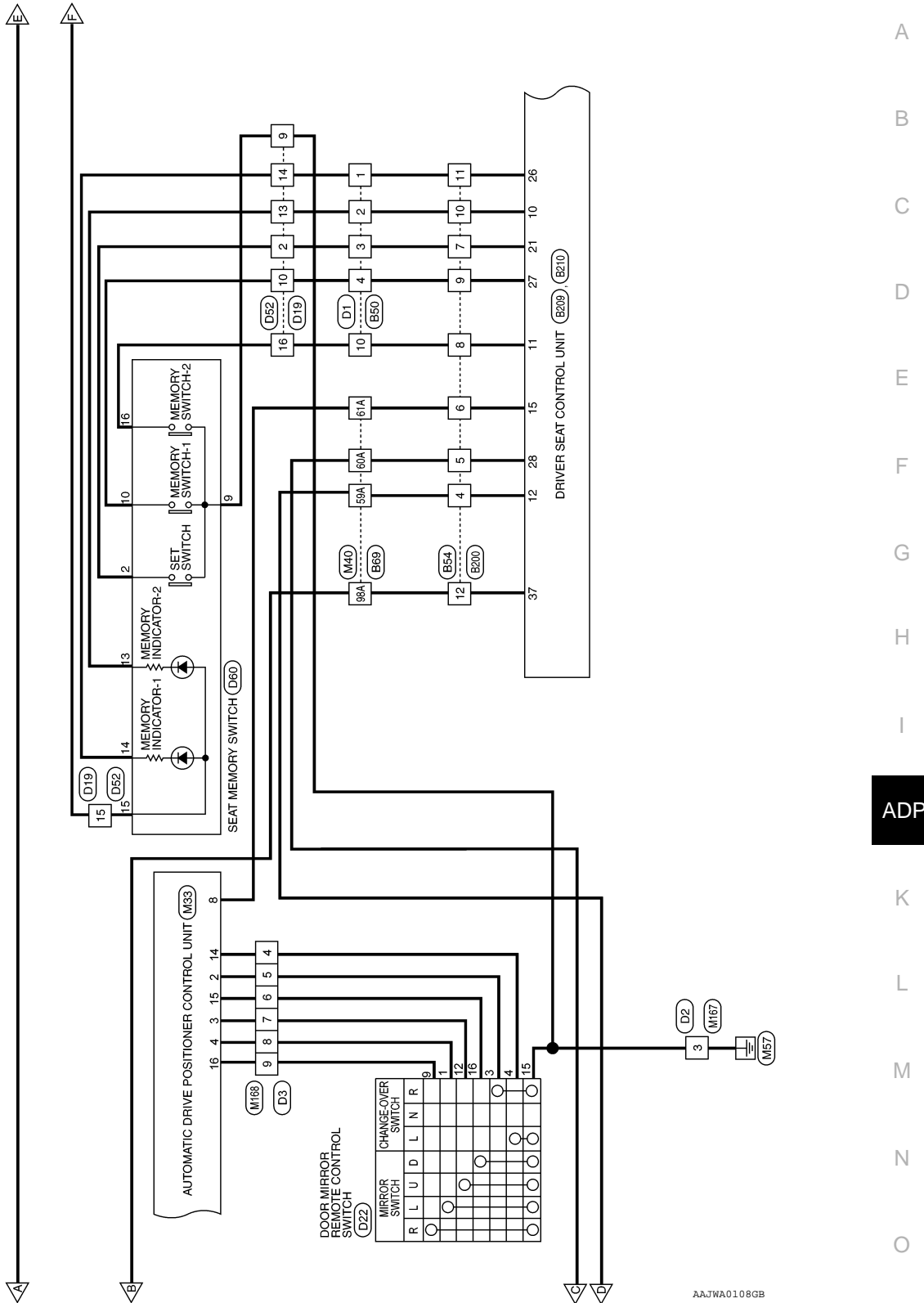

ADP

AUTOMATIC DRIVE POSITIONER SYSTEM

< WIRING DIAGRAM >

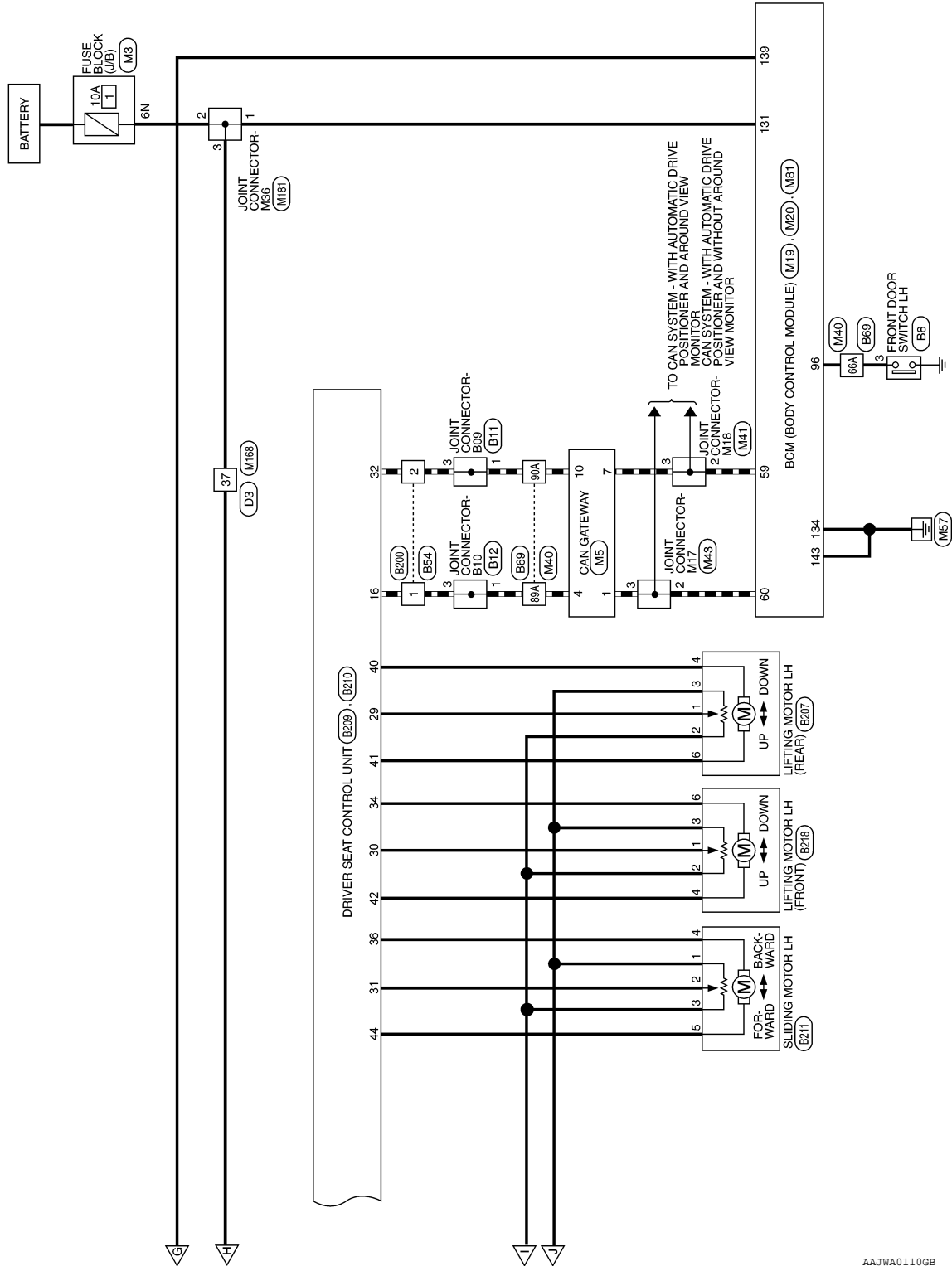

AAJWA0110GB

A
B
C
D
E
F
G
H
I
ADP
K
L
M
N
O
P

AUTOMATIC DRIVE POSITIONER SYSTEM

< WIRING DIAGRAM >

AUTOMATIC DRIVE POSITIONER - WITHOUT AROUND VIEW MONITOR SYSTEM CONNECTORS

Connector No.	M3
Connector Name	FUSE BLOCK (J/B)
Connector Color	WHITE

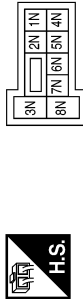

Terminal No.	Color of Wire	Signal Name
6N	W	-

Connector No.	M5
Connector Name	CAN GATEWAY
Connector Color	WHITE

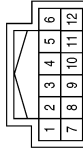

Terminal No.	Color of Wire	Signal Name
1	L	CAN-H
4	L	CAN-H
7	P	CAN-L
10	P	CAN-L

Connector No.	M16
Connector Name	ADP STEERING SWITCH
Connector Color	GRAY

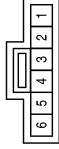

Terminal No.	Color of Wire	Signal Name
1	BR	-
2	Y	-
3	B	-
5	LG	-
6	L	-

Connector No.	M19
Connector Name	BCM (BODY CONTROL MODULE)
Connector Color	BLACK



Terminal No.	Color of Wire	Signal Name
59	P	CAN-L
60	L	CAN-H

Connector No.	M20
Connector Name	BCM (BODY CONTROL MODULE)
Connector Color	GRAY

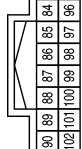

Terminal No.	Color of Wire	Signal Name
96	BG	DR DOOR SW

Connector No.	M31
Connector Name	WIRE TO WIRE
Connector Color	WHITE

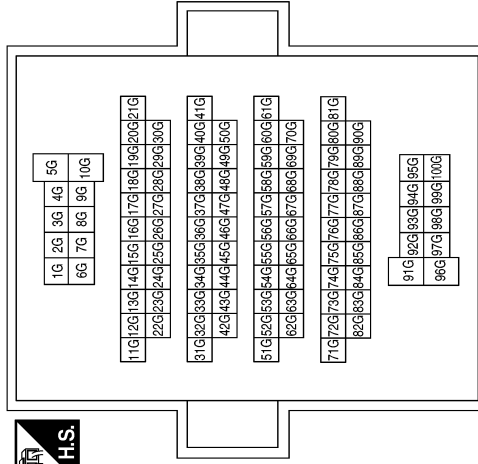

Terminal No.	Color of Wire	Signal Name
10G	W	-

AAJIA0195GB

AUTOMATIC DRIVE POSITIONER SYSTEM

< WIRING DIAGRAM >

Terminal No.	Color of Wire	Signal Name
16	W	MIRROR SW (RIGHTWARD)
17	G	MIRROR SENSOR (RH HORIZONTAL)
18	BG	MIRROR SENSOR (LH HORIZONTAL)
19	L	TELESCOPIC SW (BACKWARD)
20	Y	GND (SENSOR GND)
21	BG	POWER SUPPLY (SENSOR FOR 5V)
22	SB	MIRROR MOTOR (RH COMMON (DOWN&RIGHT))
23	LG	MIRROR MOTOR (LH VERTICAL(UP))
24	L	MIRROR MOTOR (LH HORIZONTAL(LEFT))

Terminal No.	Color of Wire	Signal Name
6	R	MIRROR SENSOR (LH VERTICAL)
7	BR	TELESCOPIC SW (FRONTWARD)
8	G	UART (TX/RX)
9	-	-
10	BR	MIRROR MOTOR (RH VERTICAL (UP))
11	G	MIRROR MOTOR (RH HORIZONTAL (LEFT))
12	BG	MIRROR MOTOR (LH COMMON (DOWN&RIGHT))
13	Y	TILT SW (DOWNWARD)
14	P	MIRROR SELECT SW (LH)
15	R	MIRROR SW (DOWNWARD)

Connector No.	M33
Connector Name	AUTOMATIC DRIVE POSITIONER CONTROL UNIT
Connector Color	WHITE

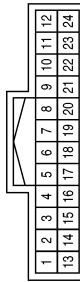

Terminal No.	Color of Wire	Signal Name
1	LG	TILT SW (UPWARD)
2	GR	MIRROR SELECTOR SW (RH)
3	G	MIRROR SW (UPWARD)
4	P	MIRROR SW (LEFTWARD)
5	W	MIRROR SENSOR (RH VERTICAL)



Terminal No.	Color of Wire	Signal Name
26	V	TELESCOPIC MOTOR (BACKWARD)
27	LG	POWER SUPPLY (SENSOR FOR 16V)
28	SB	TILT MOTOR (DOWNWARD)
29	BR	STRG MOTOR COMMON (UPWARD/FORWARD)
30	B	GND (POWER)

Connector No.	M34
Connector Name	AUTOMATIC DRIVE POSITIONER CONTROL UNIT
Connector Color	WHITE



Terminal No.	Color of Wire	Signal Name
25	L	BAT (PTC)

AAJIA0196GB

A
B
C
D
E
F
G
H
I
K
L
M
N
O
P

ADP

AUTOMATIC DRIVE POSITIONER SYSTEM

< WIRING DIAGRAM >

Connector No.	M40
Connector Name	WIRE TO WIRE
Connector Color	BROWN

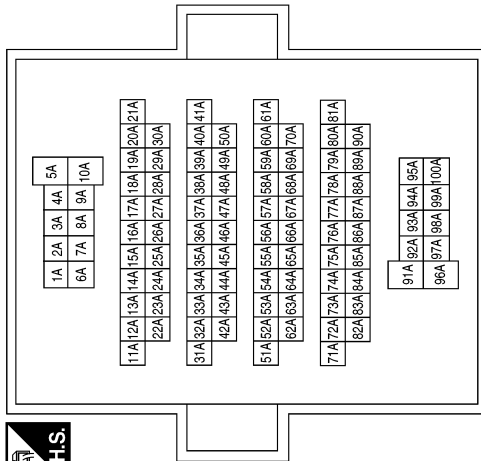

Terminal No.	Color of Wire	Signal Name
59A	SB	-
60A	L	-
61A	G	-
66A	BG	-
89A	L	-
90A	P	-
98A	Y	-

Connector No.	M41
Connector Name	JOINT CONNECTOR-M18
Connector Color	WHITE

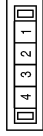

Terminal No.	Color of Wire	Signal Name
2	P	-
3	P	-

Connector No.	M43
Connector Name	JOINT CONNECTOR-M17
Connector Color	WHITE



Terminal No.	Color of Wire	Signal Name
2	L	-
3	L	-

Connector No.	M81
Connector Name	BCM (BODY CONTROL MODULE)
Connector Color	WHITE

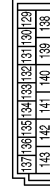

Terminal No.	Color of Wire	Signal Name
131	W	BAT BCM FUSE
134	B	GND 2
139	W	BAT POWER F/L
143	B	GND 1

Connector No.	M82
Connector Name	CIRCUIT BREAKER-2
Connector Color	WHITE



Terminal No.	Color of Wire	Signal Name
1	W	-
2	L	-

AUTOMATIC DRIVE POSITIONER SYSTEM

< WIRING DIAGRAM >

Connector No.	M94
Connector Name	TELESCOPIC MOTOR
Connector Color	BROWN



Terminal No.	Color of Wire	Signal Name
1	BR	-
2	V	-
3	Y	-
4	SB	-
5	LG	-

Connector No.	M91
Connector Name	WIRE TO WIRE
Connector Color	WHITE

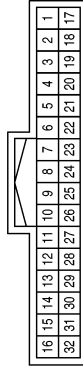

Terminal No.	Color of Wire	Signal Name
6	Y	-
7	L	-
8	BR	-
9	V	-
19	BR	-
20	SB	-
21	G	-

Connector No.	M85
Connector Name	TILT MOTOR
Connector Color	WHITE



Terminal No.	Color of Wire	Signal Name
1	BR	-
2	SB	-
3	Y	-
4	L	-
5	LG	-

Terminal No.	Color of Wire	Signal Name
8	P	-
9	W	-
16	LG	-
17	BG	-
18	L	-
33	V	-
34	Y	-
35	BG	-
36	SB	-

Connector No.	M168
Connector Name	WIRE TO WIRE
Connector Color	WHITE

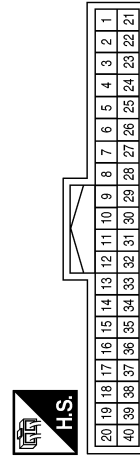

Terminal No.	Color of Wire	Signal Name
4	P	-
5	V	-
6	R	-
7	G	-

Connector No.	M167
Connector Name	WIRE TO WIRE
Connector Color	WHITE



Terminal No.	Color of Wire	Signal Name
3	B	-

AAJIA0198GB

A
B
C
D
E
F
G
H
I
K
L
M
N
O
P



AUTOMATIC DRIVE POSITIONER SYSTEM

< WIRING DIAGRAM >

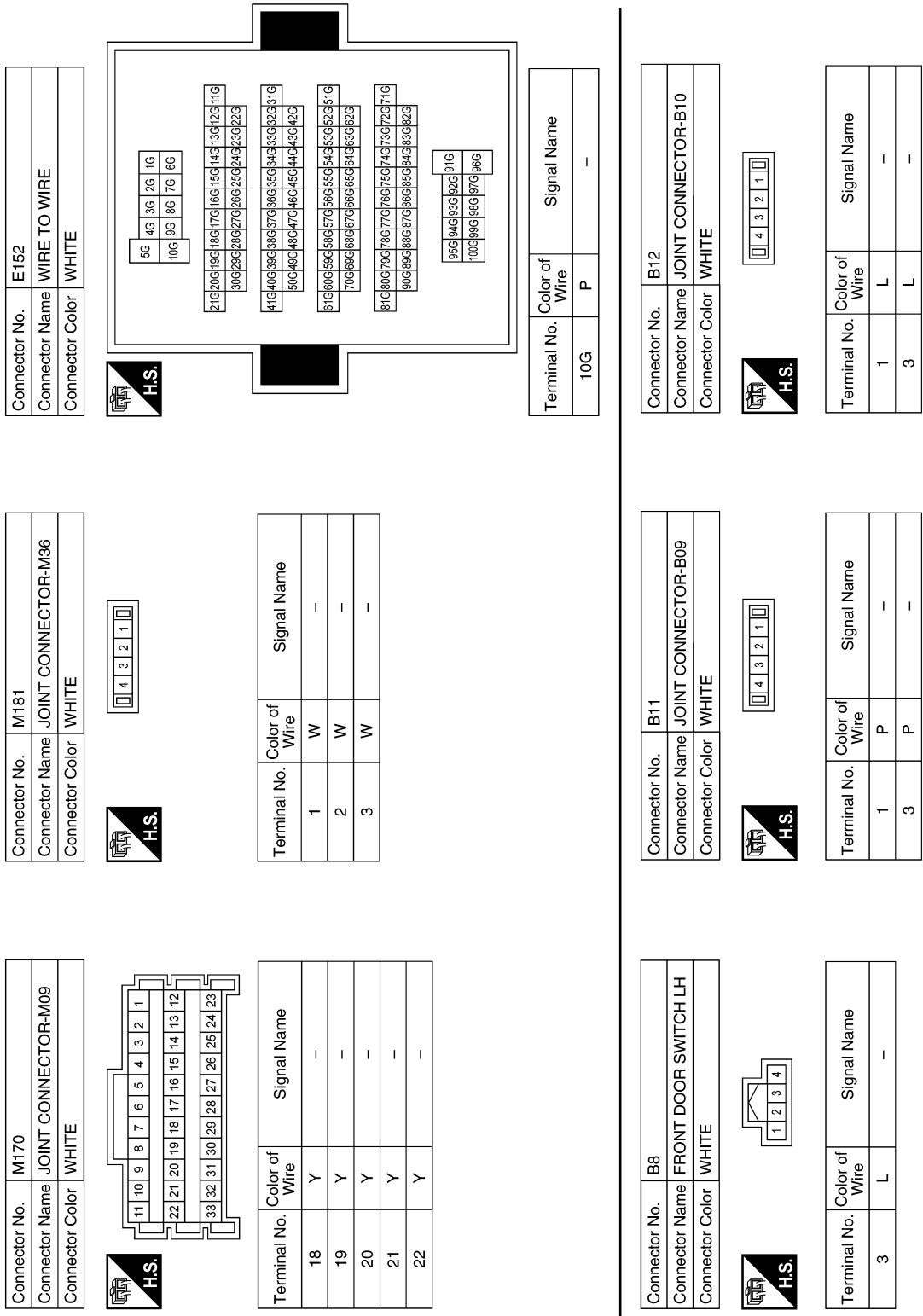

AUTOMATIC DRIVE POSITIONER SYSTEM

< WIRING DIAGRAM >

Terminal No.	Color of Wire	Signal Name
5	L	-
6	Y	-
7	SB	-
8	LG	-
9	V	-
10	BR	-
11	Y	-

Connector No.	B54
Connector Name	WIRE TO WIRE
Connector Color	BROWN

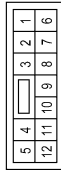

Terminal No.	Color of Wire	Signal Name
1	L	-
2	P	-
3	GR	-
4	BR	-

Connector No.	B50
Connector Name	WIRE TO WIRE
Connector Color	WHITE

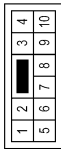

Terminal No.	Color of Wire	Signal Name
1	Y	-
2	BR	-
3	SB	-
4	V	-

Connector No.	B200
Connector Name	WIRE TO WIRE
Connector Color	BROWN

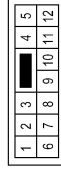

Terminal No.	Color of Wire	Signal Name
1	L	-
2	P	-
3	B	-
4	W	-
5	BG	-
6	SB	-
7	L	-
8	GR	-
9	V	-
10	G	-
11	Y	-
12	R	-

Terminal No.	Color of Wire	Signal Name
59A	BR	-
60A	L	-
61A	Y	-
66A	L	-
89A	L	-
90A	P	-
98A	L	-

Connector No.	B69
Connector Name	WIRE TO WIRE
Connector Color	GRAY

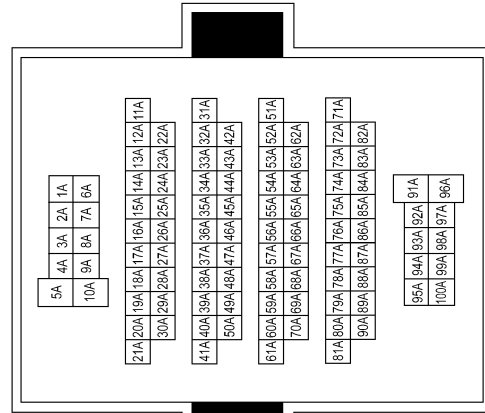
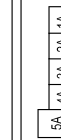

A
B
C
D
E
F
G
H
I
ADP
K
L
M
N
O
P

AUTOMATIC DRIVE POSITIONER SYSTEM

< WIRING DIAGRAM >

Terminal No.	Color of Wire	Signal Name
6	Y	-
7	L	-
8	SB	-
9	P	-
10	BG	-

Connector No.	B208
Connector Name	POWER SEAT SWITCH LH
Connector Color	WHITE

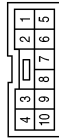

Terminal No.	Color of Wire	Signal Name
1	V	-
2	R	-
3	B	-
5	G	-

Connector No.	B207
Connector Name	LIFTING MOTOR LH (REAR)
Connector Color	WHITE



Terminal No.	Color of Wire	Signal Name
1	R	-
2	B	-
3	W	-
4	L	-
6	Y	-

Terminal No.	Color of Wire	Signal Name
21	L	SET SW
22	V	REAR LIFTER SW (UPWARD)
23	G	FRONT LIFTER SW (UPWARD)
24	P	RECLINER SW (FORWARD)
25	L	SLIDE SW (FORWARD)
26	Y	IND 1
27	V	ADDRESS 1
28	BG	PULSE (TILT)
29	R	PULSE (REAR LIFTER)
30	Y	PULSE (FRONT LIFTER)
31	L	PULSE (SLIDE)
32	W	CAN-L

Terminal No.	Color of Wire	Signal Name
9	SB	SLIDE SW (BACKWARD)
10	G	IND 2
11	GR	ADDRESS 2
12	W	PULSE (TELESCOPIC)
13	G	PULSE (RECLINER)
14	-	-
15	SB	UART (TX/RX)
16	P	CAN-H
17	-	-
18	-	-
19	-	-
20	-	-

Connector No.	B209
Connector Name	DRIVER SEAT CONTROL UNIT
Connector Color	WHITE

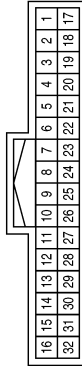

Terminal No.	Color of Wire	Signal Name
1	-	-
2	-	-
3	-	-
4	-	-
5	W	POWER SUPPLY (ENCODER)
6	R	REAR LIFTER SW (DOWNWARD)
7	Y	FRONT LIFTER SW (DOWNWARD)
8	BR	RECLINER SW (BACKWARD)

AAJIA0201GB

AUTOMATIC DRIVE POSITIONER SYSTEM

< WIRING DIAGRAM >

Connector No.	B211
Connector Name	SLIDING MOTOR LH
Connector Color	GRAY



Terminal No.	Color of Wire	Signal Name
1	W	-
2	L	-
3	B	-
4	W	-
5	G	-

Terminal No.	Color of Wire	Signal Name
39	B	GND
40	L	REAR LIFTER MOTOR (DOWNWARD)
41	Y	REAR LIFTER MOTOR (UPWARD)
42	GR	FRONT LIFTER MOTOR (UPWARD)
43	BG	RECLINER MOTOR (BACKWARD)
44	G	SLIDE MOTOR (FORWARD)

Connector No.	B210
Connector Name	DRIVER SEAT CONTROL UNIT
Connector Color	WHITE

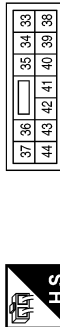

Terminal No.	Color of Wire	Signal Name
33	-	-
34	SB	FRONT LIFTER MOTOR (DOWNWARD)
35	V	RECLINER MOTOR (FORWARD)
36	W	SLIDE MOTOR (BACKWARD)
37	R	BAT (PTC)
38	-	-

Connector No.	D1
Connector Name	WIRE TO WIRE
Connector Color	WHITE

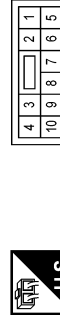

Terminal No.	Color of Wire	Signal Name
1	Y	-
2	LG	-
3	SB	-
4	BR	-
10	L	-

Connector No.	B218
Connector Name	LIFTING MOTOR LH (FRONT)
Connector Color	WHITE



Terminal No.	Color of Wire	Signal Name
1	Y	-
2	B	-
3	W	-
4	GR	-
5	-	-
6	SB	-

Connector No.	B217
Connector Name	RECLINING MOTOR LH
Connector Color	WHITE



Terminal No.	Color of Wire	Signal Name
1	G	-
2	B	-
3	W	-
4	BG	-
5	-	-
6	V	-

AAJIA0202GB

A
B
C
D
E
F
G
H
I
K
L
M
N
O
P



AUTOMATIC DRIVE POSITIONER SYSTEM

< WIRING DIAGRAM >

Terminal No.	Color of Wire	Signal Name
33	V	-
34	Y	-
35	BG	-
36	SB	-

Connector No.	D3
Connector Name	WIRE TO WIRE
Connector Color	WHITE

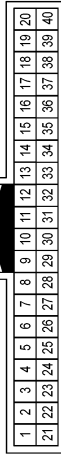

Terminal No.	Color of Wire	Signal Name
16	LG	-
17	BG	-
18	L	-

Connector No.	D2
Connector Name	WIRE TO WIRE
Connector Color	WHITE

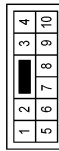

Terminal No.	Color of Wire	Signal Name
3	B	-

Connector No.	D22
Connector Name	DOOR MIRROR REMOTE CONTROL SWITCH
Connector Color	GRAY

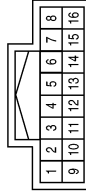

Terminal No.	Color of Wire	Signal Name
1	V	-
3	LG	-
4	SB	-
9	Y	-
12	BR	-
15	B	-
16	L	-

Connector No.	D19
Connector Name	WIRE TO WIRE
Connector Color	WHITE

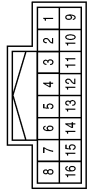

Terminal No.	Color of Wire	Signal Name
2	SB	-
9	B	-
10	BR	-
13	LG	-
14	Y	-
15	V	-
16	L	-

Connector No.	D4
Connector Name	DOOR MIRROR LH (WITHOUT AROUND VIEW MONITOR SYSTEM)
Connector Color	WHITE

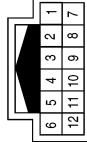

Terminal No.	Color of Wire	Signal Name
3	SB	-
4	BG	-
5	Y	-
6	V	-
8	LG	-
9	L	-
10	BG	-

AAJIA0203GB

AUTOMATIC DRIVE POSITIONER SYSTEM

< WIRING DIAGRAM >

Connector No.	D101
Connector Name	WIRE TO WIRE
Connector Color	WHITE

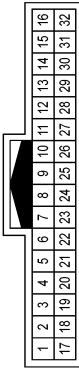
Terminal No.	Color of Wire	Signal Name
6	G	-
7	Y	-
8	W	-
9	BG	-
19	BR	-
20	SB	-
21	LG	-

Connector No.	D60
Connector Name	SEAT MEMORY SWITCH
Connector Color	WHITE

Terminal No.	Color of Wire	Signal Name
2	SB	-
9	B	-
10	BR	-
13	LG	-
14	Y	-
15	V	-
16	L	-

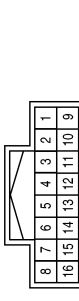
Connector No.	D52
Connector Name	WIRE TO WIRE
Connector Color	WHITE

Terminal No.	Color of Wire	Signal Name
2	SB	-
9	B	-
10	BR	-
13	LG	-
14	Y	-
15	V	-
16	L	-

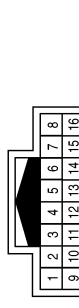
Connector No.	D107
Connector Name	DOOR MIRROR RH (WITHOUT AROUND VIEW MONITOR SYSTEM)
Connector Color	WHITE

Terminal No.	Color of Wire	Signal Name
3	V	-
4	BR	-
5	L	-
6	Y	-
8	BR	-
9	LG	-
10	SB	-

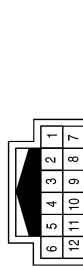
WITH AROUND VIEW MONITOR

AAJIA0204GB

A
B
C
D
E
F
G
H
I
K
L
M
N
O
P

ADP

AUTOMATIC DRIVE POSITIONER SYSTEM

< WIRING DIAGRAM >

WITH AROUND VIEW MONITOR : Wiring Diagram

INFOID:000000008901489

AUTOMATIC DRIVE POSITIONER - WITH AROUND VIEW MONITOR

ⓉⓏ : WITH ELECTRIC TILT AND TELESCOPIC STEERING COLUMN

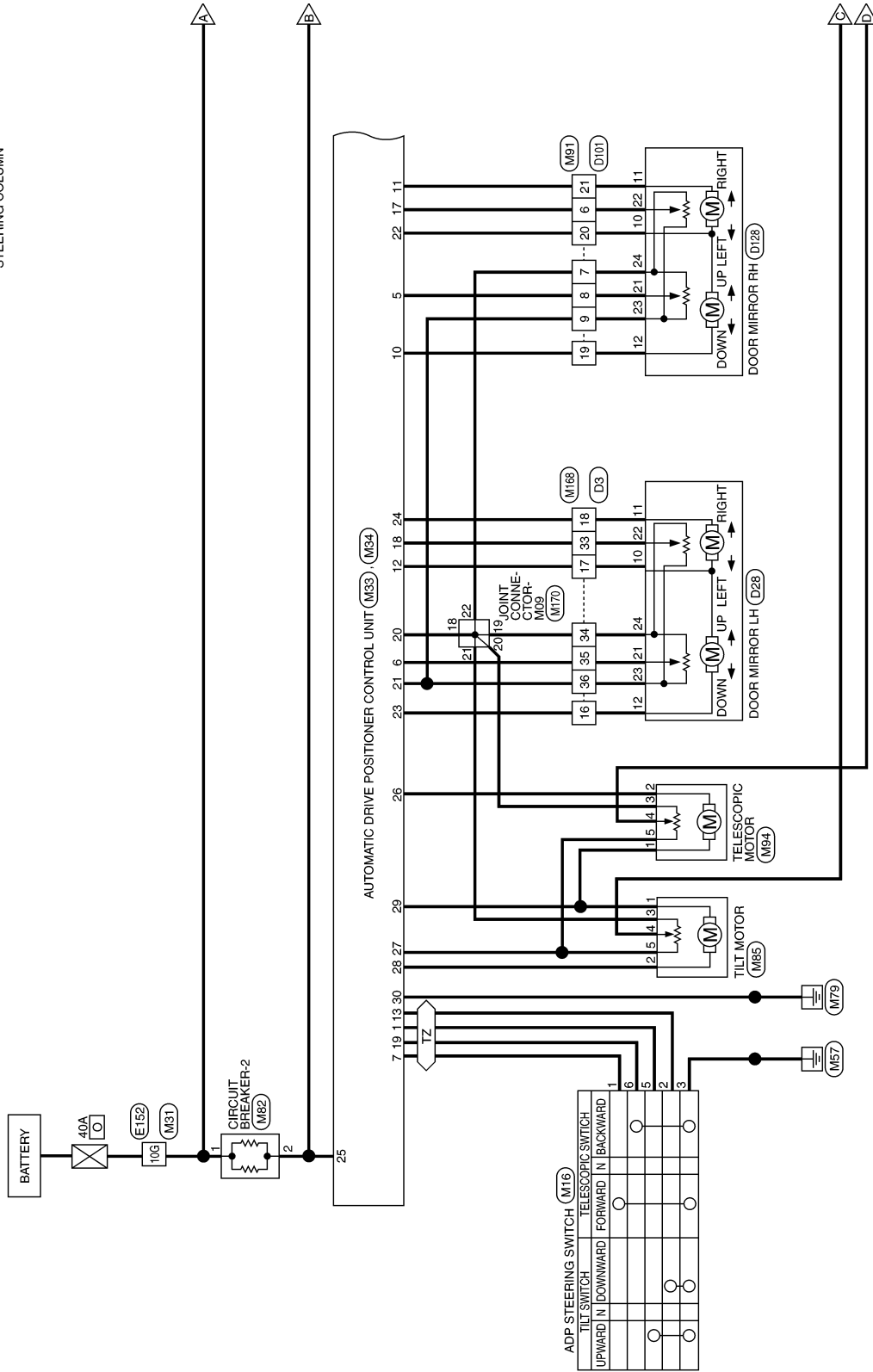

AAJWA0119GB

AUTOMATIC DRIVE POSITIONER SYSTEM

< WIRING DIAGRAM >

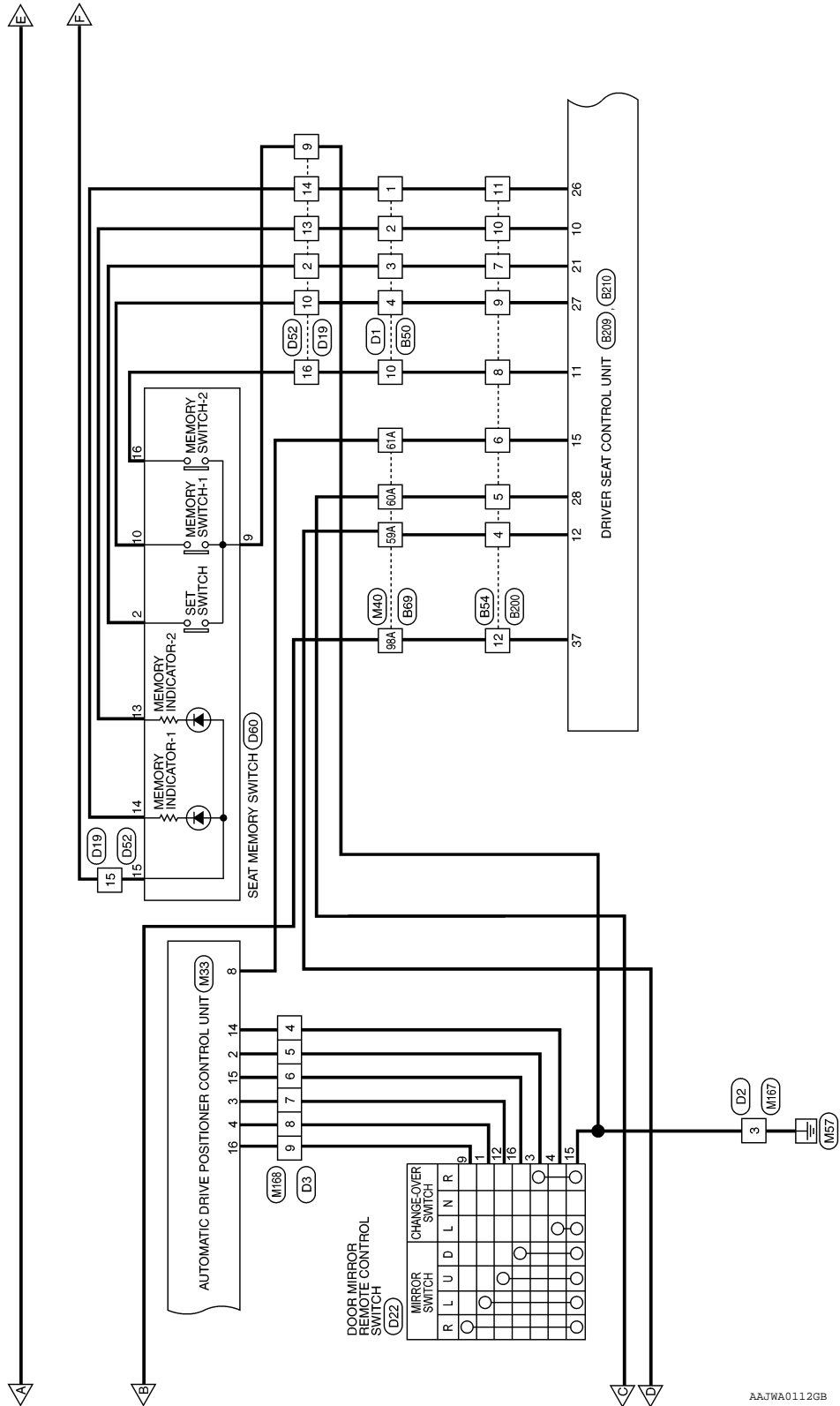

A
B
C
D
E
F
G
H
I
ADP
K
L
M
N
O
P

AUTOMATIC DRIVE POSITIONER SYSTEM

< WIRING DIAGRAM >

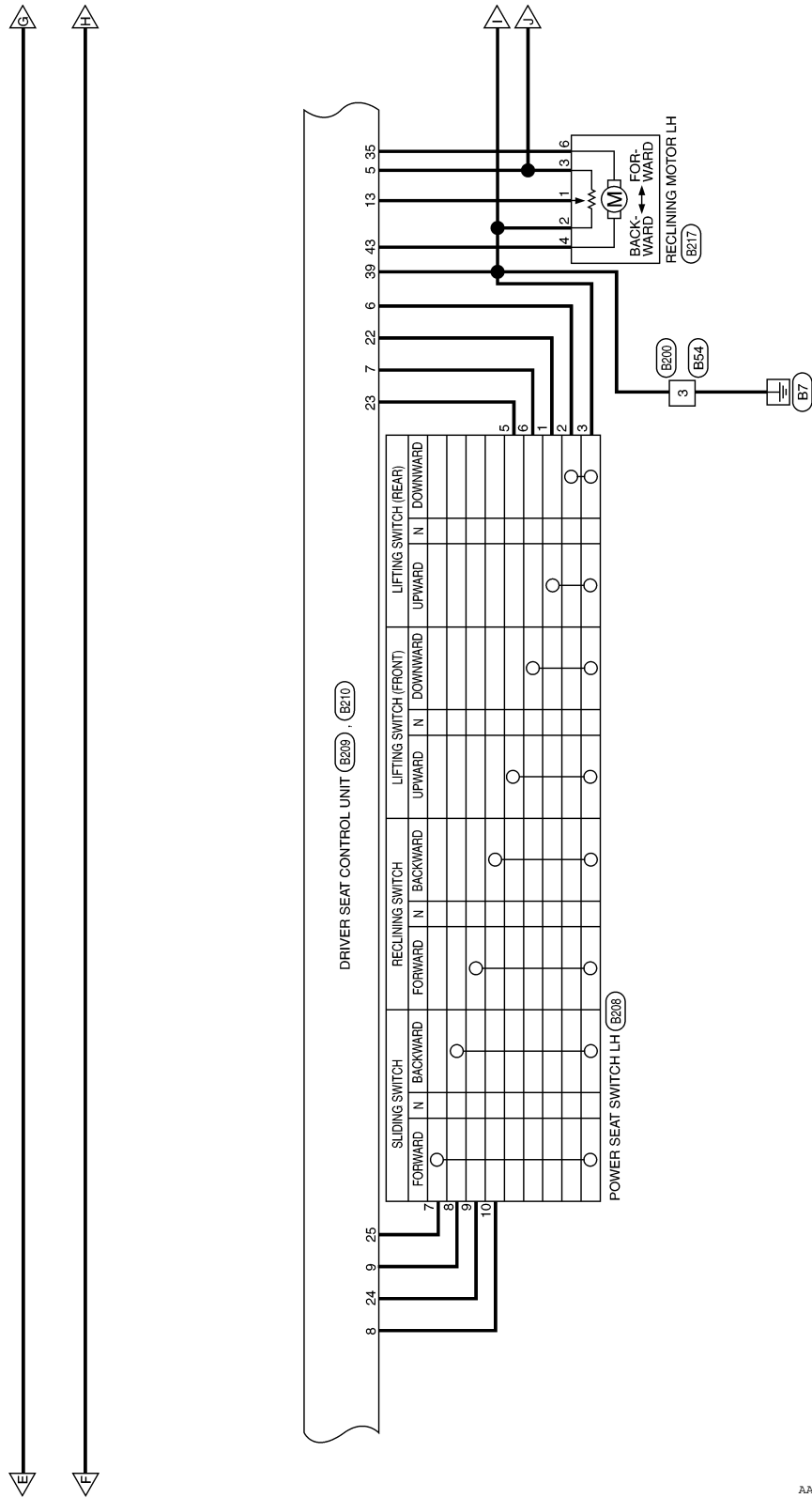

AAJWA0113GB

AUTOMATIC DRIVE POSITIONER SYSTEM

< WIRING DIAGRAM >

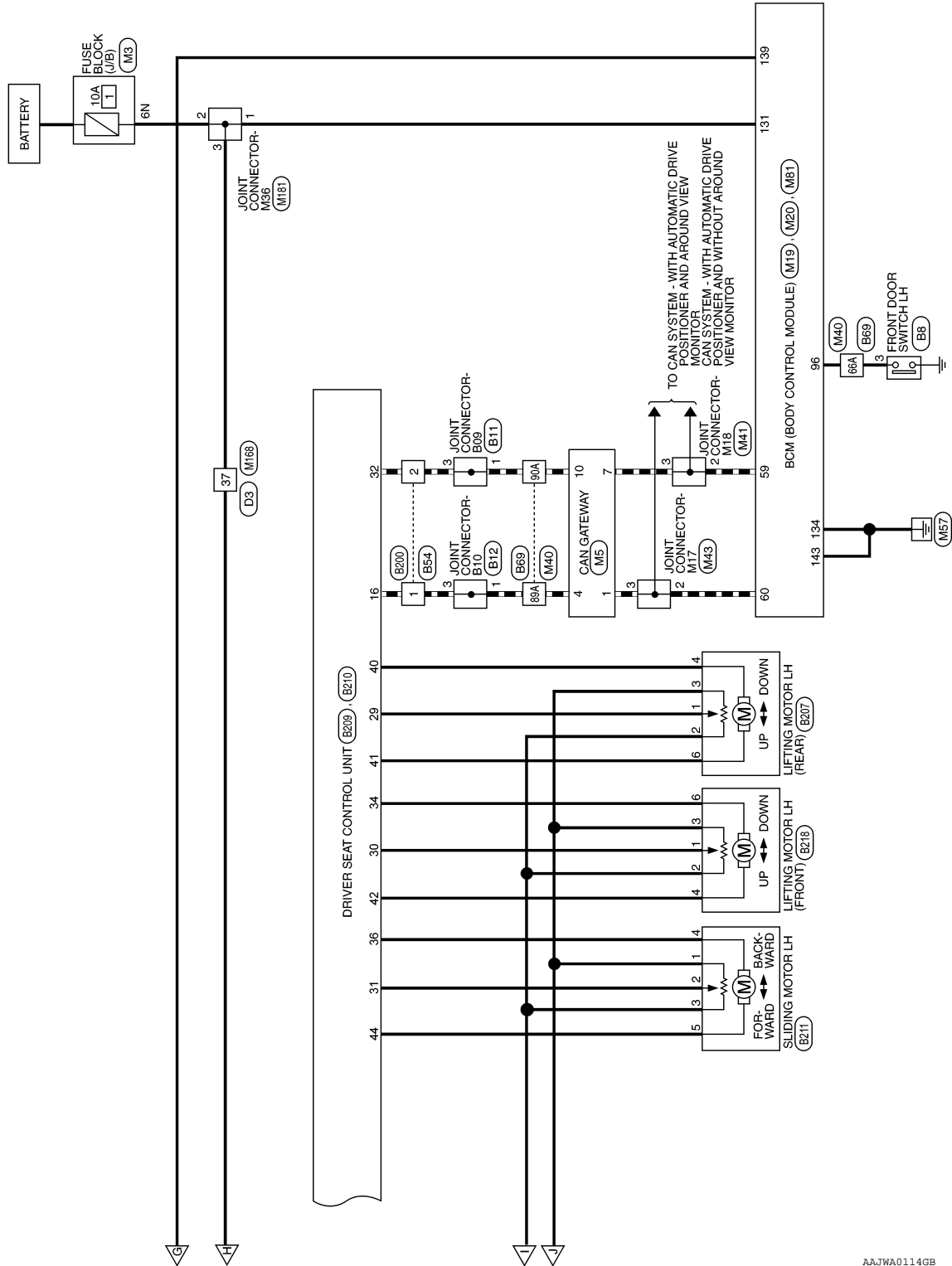

AAJWA0114GB

A
B
C
D
E
F
G
H
I
J
K
L
M
N
O
P

ADP

AUTOMATIC DRIVE POSITIONER SYSTEM

< WIRING DIAGRAM >

AUTOMATIC DRIVE POSITIONER - WITH AROUND VIEW MONITOR CONNECTORS

Connector No.	M3
Connector Name	FUSE BLOCK (J/B)
Connector Color	WHITE

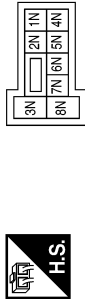

Terminal No.	Color of Wire	Signal Name
6N	W	-

Connector No.	M5
Connector Name	CAN GATEWAY
Connector Color	WHITE

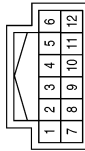

Terminal No.	Color of Wire	Signal Name
1	L	CAN-H
4	L	CAN-H
7	P	CAN-L
10	P	CAN-L

Connector No.	M16
Connector Name	ADP STEERING SWITCH
Connector Color	GRAY

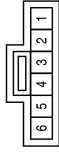

Terminal No.	Color of Wire	Signal Name
1	BR	-
2	Y	-
3	B	-
5	LG	-
6	L	-

Connector No.	M19
Connector Name	BCM (BODY CONTROL MODULE)
Connector Color	BLACK

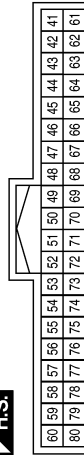

Terminal No.	Color of Wire	Signal Name
59	P	CAN-L
60	L	CAN-H

Connector No.	M20
Connector Name	BCM (BODY CONTROL MODULE)
Connector Color	GRAY

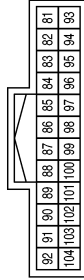

Terminal No.	Color of Wire	Signal Name
96	BG	DR DOOR SW

Connector No.	M31
Connector Name	WIRE TO WIRE
Connector Color	WHITE

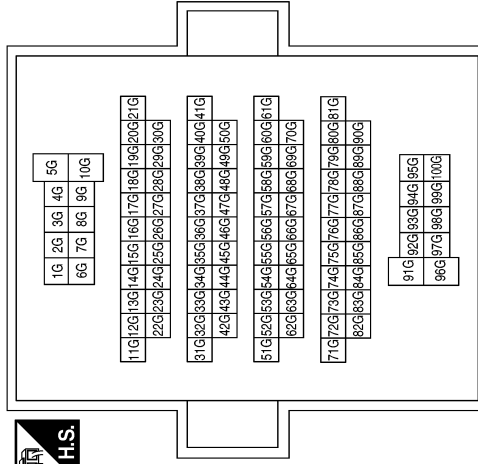

Terminal No.	Color of Wire	Signal Name
10G	W	-

AAJIA0205GB

AUTOMATIC DRIVE POSITIONER SYSTEM

< WIRING DIAGRAM >

Terminal No.	Color of Wire	Signal Name
16	W	MIRROR SW (RIGHTWARD)
17	G	MIRROR SENSOR (RH HORIZONTAL)
18	BG	MIRROR SENSOR (LH HORIZONTAL)
19	L	TELESCOPIC SW (BACKWARD)
20	Y	GND (SENSOR GND)
21	BG	POWER SUPPLY (SENSOR FOR 5V)
22	SB	MIRROR MOTOR (RH COMMON (DOWN&RIGHT))
23	LG	MIRROR MOTOR (LH VERTICAL(UP))
24	L	MIRROR MOTOR (LH HORIZONTAL(LEFT))

Terminal No.	Color of Wire	Signal Name
6	R	MIRROR SENSOR (LH VERTICAL)
7	BR	TELESCOPIC SW (FRONTWARD)
8	G	UART (TX/RX)
9	-	-
10	BR	MIRROR MOTOR (RH VERTICAL (UP))
11	G	MIRROR MOTOR (RH HORIZONTAL (LEFT))
12	BG	MIRROR MOTOR (LH COMMON (DOWN&RIGHT))
13	Y	TILT SW (DOWNWARD)
14	P	MIRROR SELECT SW (LH)
15	R	MIRROR SW (DOWNWARD)

Connector No.	M33
Connector Name	AUTOMATIC DRIVE POSITIONER CONTROL UNIT
Connector Color	WHITE

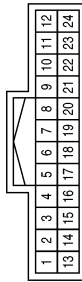

Terminal No.	Color of Wire	Signal Name
1	LG	TILT SW (UPWARD)
2	GR	MIRROR SELECTOR SW (RH)
3	G	MIRROR SW (UPWARD)
4	P	MIRROR SW (LEFTWARD)
5	W	MIRROR SENSOR (RH VERTICAL)

Terminal No.	Color of Wire	Signal Name
26	V	TELESCOPIC MOTOR (BACKWARD)
27	LG	POWER SUPPLY (SENSOR FOR 16V)
28	SB	TILT MOTOR (DOWNWARD)
29	BR	STRG MOTOR COMMON (UPWARD/FORWARD)
30	B	GND (POWER)

Connector No.	M34
Connector Name	AUTOMATIC DRIVE POSITIONER CONTROL UNIT
Connector Color	WHITE



Terminal No.	Color of Wire	Signal Name
25	L	BAT (PTC)

AAJIA0206GB

A
B
C
D
E
F
G
H
I
K
L
M
N
O
P

ADP

AUTOMATIC DRIVE POSITIONER SYSTEM

< WIRING DIAGRAM >

Connector No.	M40
Connector Name	WIRE TO WIRE
Connector Color	BROWN

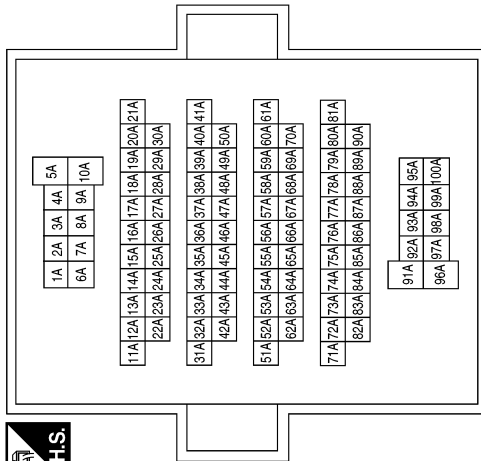

Terminal No.	Color of Wire	Signal Name
59A	SB	-
60A	L	-
61A	G	-
66A	BG	-
89A	L	-
90A	P	-
98A	Y	-

Connector No.	M41
Connector Name	JOINT CONNECTOR-M18
Connector Color	WHITE

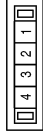

Terminal No.	Color of Wire	Signal Name
2	P	-
3	P	-

Connector No.	M43
Connector Name	JOINT CONNECTOR-M17
Connector Color	WHITE



Terminal No.	Color of Wire	Signal Name
2	L	-
3	L	-

Connector No.	M81
Connector Name	BCM (BODY CONTROL MODULE)
Connector Color	WHITE

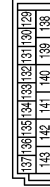

Terminal No.	Color of Wire	Signal Name
131	W	BAT BCM FUSE
134	B	GND 2
139	W	BAT POWER F/L
143	B	GND 1

Connector No.	M82
Connector Name	CIRCUIT BREAKER-2
Connector Color	WHITE



Terminal No.	Color of Wire	Signal Name
1	W	-
2	L	-

AUTOMATIC DRIVE POSITIONER SYSTEM

< WIRING DIAGRAM >

Connector No.	M94
Connector Name	TELESCOPIC MOTOR
Connector Color	BROWN



Terminal No.	Color of Wire	Signal Name
1	BR	-
2	V	-
3	Y	-
4	SB	-
5	LG	-

Connector No.	M91
Connector Name	WIRE TO WIRE
Connector Color	WHITE

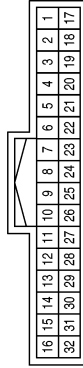

Terminal No.	Color of Wire	Signal Name
6	Y	-
7	L	-
8	BR	-
9	V	-
19	BR	-
20	SB	-
21	G	-

Connector No.	M85
Connector Name	TILT MOTOR
Connector Color	WHITE



Terminal No.	Color of Wire	Signal Name
1	BR	-
2	SB	-
3	Y	-
4	L	-
5	LG	-

Terminal No.	Color of Wire	Signal Name
8	P	-
9	W	-
16	LG	-
17	BG	-
18	L	-
33	V	-
34	Y	-
35	BG	-
36	SB	-

Connector No.	M168
Connector Name	WIRE TO WIRE
Connector Color	WHITE

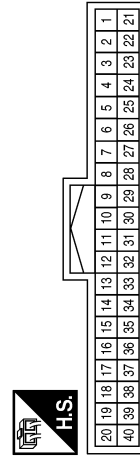

Terminal No.	Color of Wire	Signal Name
4	P	-
5	V	-
6	R	-
7	G	-

Connector No.	M167
Connector Name	WIRE TO WIRE
Connector Color	WHITE



Terminal No.	Color of Wire	Signal Name
3	B	-

AAJIA0208GB

A
B
C
D
E
F
G
H
I
K
L
M
N
O
P

ADP

AUTOMATIC DRIVE POSITIONER SYSTEM

< WIRING DIAGRAM >

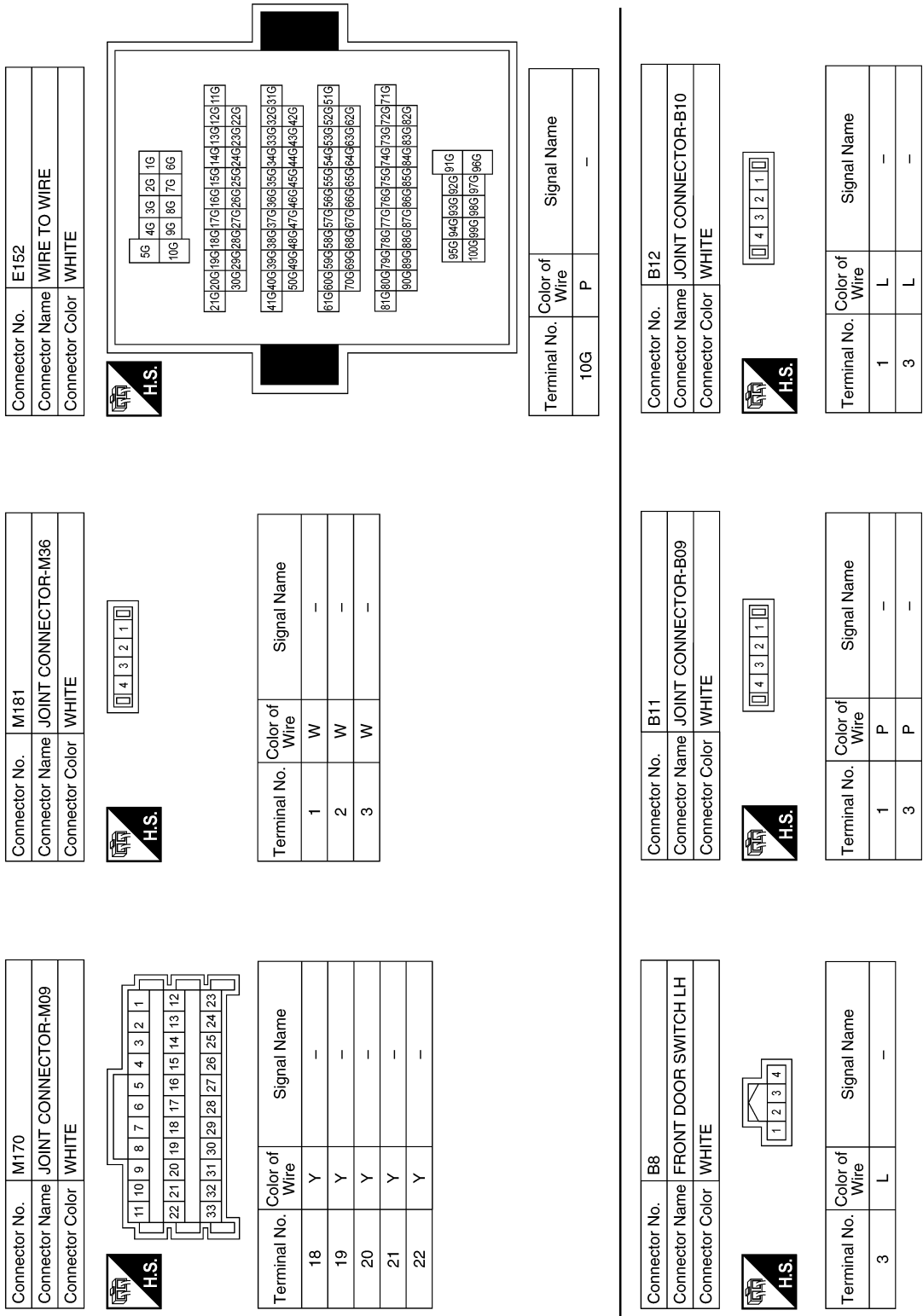

AUTOMATIC DRIVE POSITIONER SYSTEM

< WIRING DIAGRAM >

Terminal No.	Color of Wire	Signal Name
5	L	-
6	Y	-
7	SB	-
8	LG	-
9	V	-
10	BR	-
11	Y	-

Connector No.	B54
Connector Name	WIRE TO WIRE
Connector Color	BROWN

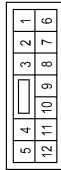

Terminal No.	Color of Wire	Signal Name
1	L	-
2	P	-
3	GR	-
4	BR	-

Connector No.	B50
Connector Name	WIRE TO WIRE
Connector Color	WHITE

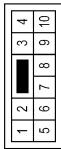

Terminal No.	Color of Wire	Signal Name
1	Y	-
2	BR	-
3	SB	-
4	V	-

Connector No.	B200
Connector Name	WIRE TO WIRE
Connector Color	BROWN

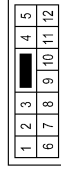

Terminal No.	Color of Wire	Signal Name
1	L	-
2	P	-
3	B	-
4	W	-
5	BG	-
6	SB	-
7	L	-
8	GR	-
9	V	-
10	G	-
11	Y	-
12	R	-

Terminal No.	Color of Wire	Signal Name
59A	BR	-
60A	L	-
61A	Y	-
66A	L	-
89A	L	-
90A	P	-
98A	L	-

Connector No.	B69
Connector Name	WIRE TO WIRE
Connector Color	GRAY

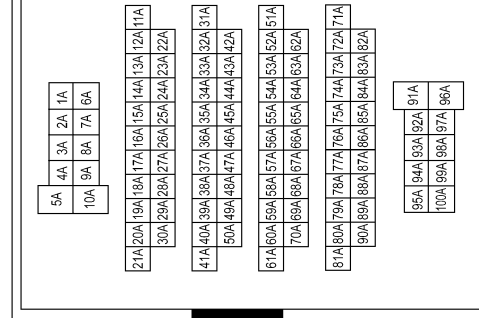

AAJIA0210GB

A
B
C
D
E
F
G
H
I
ADP
K
L
M
N
O
P

AUTOMATIC DRIVE POSITIONER SYSTEM

< WIRING DIAGRAM >

Terminal No.	Color of Wire	Signal Name
6	Y	-
7	L	-
8	SB	-
9	P	-
10	BG	-

Connector No.	B208
Connector Name	POWER SEAT SWITCH LH
Connector Color	WHITE

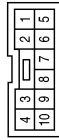

Terminal No.	Color of Wire	Signal Name
1	V	-
2	R	-
3	B	-
5	G	-

Connector No.	B207
Connector Name	LIFTING MOTOR LH (REAR)
Connector Color	WHITE



Terminal No.	Color of Wire	Signal Name
1	R	-
2	B	-
3	W	-
4	L	-
6	Y	-

Terminal No.	Color of Wire	Signal Name
21	L	SET SW
22	V	REAR LIFTER SW (UPWARD)
23	G	FRONT LIFTER SW (UPWARD)
24	P	RECLINER SW (FORWARD)
25	L	SLIDE SW (FORWARD)
26	Y	IND 1
27	V	ADDRESS 1
28	BG	PULSE (TILT)
29	R	PULSE (REAR LIFTER)
30	Y	PULSE (FRONT LIFTER)
31	L	PULSE (SLIDE)
32	W	CAN-L

Terminal No.	Color of Wire	Signal Name
9	SB	SLIDE SW (BACKWARD)
10	G	IND 2
11	GR	ADDRESS 2
12	W	PULSE (TELESCOPIC)
13	G	PULSE (RECLINER)
14	-	-
15	SB	UART (TX/RX)
16	P	CAN-H
17	-	-
18	-	-
19	-	-
20	-	-

Connector No.	B209
Connector Name	DRIVER SEAT CONTROL UNIT
Connector Color	WHITE

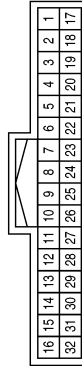

Terminal No.	Color of Wire	Signal Name
1	-	-
2	-	-
3	-	-
4	-	-
5	W	POWER SUPPLY (ENCODER)
6	R	REAR LIFTER SW (DOWNWARD)
7	Y	FRONT LIFTER SW (DOWNWARD)
8	BR	RECLINER SW (BACKWARD)

AAJIA0211GB

AUTOMATIC DRIVE POSITIONER SYSTEM

< WIRING DIAGRAM >

Connector No.	B211
Connector Name	SLIDING MOTOR LH
Connector Color	GRAY



Terminal No.	Color of Wire	Signal Name
1	W	-
2	L	-
3	B	-
4	W	-
5	G	-

Terminal No.	Color of Wire	Signal Name
39	B	GND
40	L	REAR LIFTER MOTOR (DOWNWARD)
41	Y	REAR LIFTER MOTOR (UPWARD)
42	GR	FRONT LIFTER MOTOR (UPWARD)
43	BG	RECLINER MOTOR (BACKWARD)
44	G	SLIDE MOTOR (FORWARD)

Connector No.	B210
Connector Name	DRIVER SEAT CONTROL UNIT
Connector Color	WHITE

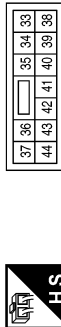

Terminal No.	Color of Wire	Signal Name
33	-	-
34	SB	FRONT LIFTER MOTOR (DOWNWARD)
35	V	RECLINER MOTOR (FORWARD)
36	W	SLIDE MOTOR (BACKWARD)
37	R	BAT (PTC)
38	-	-

Connector No.	D1
Connector Name	WIRE TO WIRE
Connector Color	WHITE



Terminal No.	Color of Wire	Signal Name
1	Y	-
2	LG	-
3	SB	-
4	BR	-
10	L	-

Connector No.	B218
Connector Name	LIFTING MOTOR LH (FRONT)
Connector Color	WHITE



Terminal No.	Color of Wire	Signal Name
1	Y	-
2	B	-
3	W	-
4	GR	-
5	-	-
6	SB	-

Connector No.	B217
Connector Name	RECLINING MOTOR LH
Connector Color	WHITE



Terminal No.	Color of Wire	Signal Name
1	G	-
2	B	-
3	W	-
4	BG	-
5	-	-
6	V	-

AAJIA0212GB

A
B
C
D
E
F
G
H
I
K
L
M
N
O
P

ADP

AUTOMATIC DRIVE POSITIONER SYSTEM

< WIRING DIAGRAM >

Terminal No.	Color of Wire	Signal Name
33	V	-
34	Y	-
35	BG	-
36	SB	-

Connector No.	D3
Connector Name	WIRE TO WIRE
Connector Color	WHITE



1	2	3	4	5	6	7	8	9	10	11	12	13	14	15	16	17	18	19	20
21	22	23	24	25	26	27	28	29	30	31	32	33	34	35	36	37	38	39	40

Terminal No.	Color of Wire	Signal Name
16	LG	-
17	BG	-
18	L	-

Connector No.	D2
Connector Name	WIRE TO WIRE
Connector Color	WHITE



1	2	3	4
5	6	7	8
9	10		

Terminal No.	Color of Wire	Signal Name
3	B	-

Connector No.	D28
Connector Name	DOOR MIRROR LH (WITH AROUND VIEW MONITOR SYSTEM)
Connector Color	WHITE



12	11	10	9	8	7	6	5	4	3	2	1
24	23	22	21	20	19	18	17	16	15	14	13

Connector No.	D22
Connector Name	DOOR MIRROR REMOTE CONTROL SWITCH
Connector Color	GRAY



1	2	3	4	5	6	7	8
9	10	11	12	13	14	15	16

Terminal No.	Color of Wire	Signal Name
10	BG	-
11	L	-
12	LG	-
21	BG	-
22	V	-
23	SB	-
24	Y	-

Terminal No.	Color of Wire	Signal Name
1	V	-
3	LG	-
4	SB	-
9	Y	-
12	BR	-
15	B	-
16	L	-

Connector No.	D19
Connector Name	WIRE TO WIRE
Connector Color	WHITE



8	7	6	5	4	3	2	1
16	15	14	13	12	11	10	9

Terminal No.	Color of Wire	Signal Name
2	SB	-
9	B	-
10	BR	-
13	LG	-
14	Y	-
15	V	-
16	L	-

AAJIA0213GB

AUTOMATIC DRIVE POSITIONER SYSTEM

< WIRING DIAGRAM >

Connector No.	D52
Connector Name	WIRE TO WIRE
Connector Color	WHITE

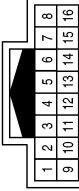
Terminal No.	Color of Wire	Signal Name
2	SB	-
9	B	-
10	BR	-
13	LG	-
14	Y	-
15	V	-
16	L	-

Connector No.	D60
Connector Name	SEAT MEMORY SWITCH
Connector Color	WHITE

Terminal No.	Color of Wire	Signal Name
2	SB	-
9	B	-
10	BR	-
13	LG	-
14	Y	-
15	V	-
16	L	-

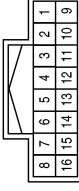
Connector No.	D101
Connector Name	WIRE TO WIRE
Connector Color	WHITE

Terminal No.	Color of Wire	Signal Name
6	Y	-
7	L	-
8	BR	-
9	V	-
19	BR	-
20	SB	-
21	LG	-

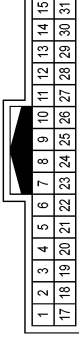
Connector No.	D128
Connector Name	DOOR MIRROR RH (WITH AROUND VIEW MONITOR SYSTEM)
Connector Color	WHITE

Terminal No.	Color of Wire	Signal Name
10	SB	-
11	LG	-
12	BR	-
21	BR	-
22	Y	-
23	V	-
24	L	-

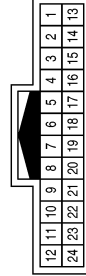
AAJIA0214GB

A
B
C
D
E
F
G
H
I
ADP
K
L
M
N
O
P

DIAGNOSIS AND REPAIR WORK FLOW

< BASIC INSPECTION >

BASIC INSPECTION

DIAGNOSIS AND REPAIR WORK FLOW

Work Flow

INFOID:000000008901490

WORK FLOW

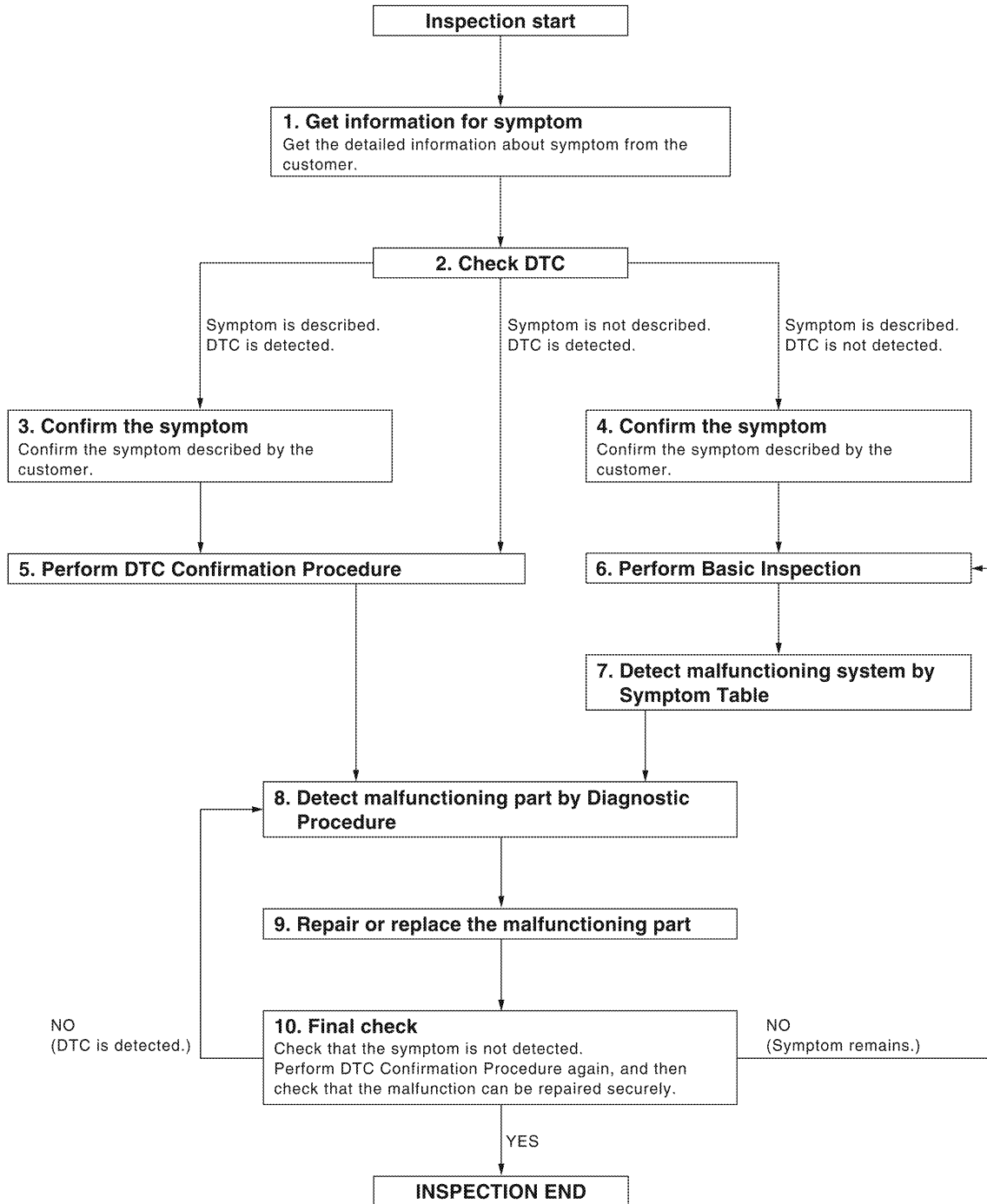

ALKIA0538GB

DETAILED FLOW

DIAGNOSIS AND REPAIR WORK FLOW

< BASIC INSPECTION >

1. GET INFORMATION FOR SYMPTOM

Get the detailed information from the customer about the symptom (the condition and the environment when the incident/malfunction occurred).

>> GO TO 2.

2. CHECK DTC WITH AUTOMATIC DRIVE POSITIONER SYSTEM

Check "Self Diagnostic Result" with CONSULT.

Refer to [ADP-31, "DTC Index"](#).

Is any symptom described and any DTC is displayed?

Symptom is described, DTC is displayed.>>GO TO 3.

Symptom is not described, DTC is displayed.>>GO TO 7.

Symptom is described, DTC is not displayed.>>GO TO 4.

3. CONFIRM THE SYMPTOM

Try to confirm the symptom described by the customer.

>> GO TO 7.

4. CONFIRM THE SYMPTOM

Try to confirm the symptom described by the customer.

>> GO TO 5.

5. CHECK NORMAL OPERATING CONDITION

Check normal operating condition. Refer to [ADP-155, "Description"](#).

Is the incident normal operation?

YES >> Inspection End.

NO >> GO TO 6.

6. PERFORM BASIC INSPECTION

Isolate the malfunctioning point with a basic inspection.

>> GO TO 8.

7. PERFORM DTC CONFIRMATION PROCEDURE

Perform the confirmation procedure for the detected DTC.

Is the DTC displayed?

YES >> GO TO 9.

NO >> Check intermittent incident. Refer to [GI-49, "Intermittent Incident"](#).

8. PERFORM COMPONENT FUNCTION CHECK

Perform the component function check for the isolated malfunctioning point.

>> GO TO 9.

9. DETECT MALFUNCTIONING PART BY DIAGNOSTIC PROCEDURE

Isolate the malfunctioning point by performing the diagnosis procedure relevant to the symptom during the component diagnosis.

>> GO TO 10.

10. REPAIR OR REPLACE

Repair or replace the malfunctioning part.

A
B
C
D
E
F
G
H
I
K
L
M
N
O
P

ADP

DIAGNOSIS AND REPAIR WORK FLOW

< BASIC INSPECTION >

>> GO TO 11.

11. FINAL CHECK

Perform the DTC confirmation procedure (if DTC is detected) or component function check (if no DTC is detected) again, and then check that the malfunction can be repaired securely.

Are all malfunctions corrected?

YES >> Inspection End.

Symptom is detected.>> GO TO 4.

DTC is detected.>> GO TO 7.

INSPECTION AND ADJUSTMENT

< BASIC INSPECTION >

INSPECTION AND ADJUSTMENT

ADDITIONAL SERVICE WHEN REMOVING BATTERY NEGATIVE TERMINAL

ADDITIONAL SERVICE WHEN REMOVING BATTERY NEGATIVE TERMINAL : Description

INFOID:000000008901491

Each function is reset to the following condition when the battery terminal is disconnected.

Function	Condition	Procedure
Memory (Seat, steering, mirror)	Erased	Perform storing
Entry/exit assist	ON	Perform initialization
		Set slide amount* ¹
Intelligent Key interlock	Erased	Perform initialization
		Perform storing

*¹: Default value is 40 mm.

NOTE:

Notice that disconnecting the battery when detected DTC are present will erase the DTC memory.

ADDITIONAL SERVICE WHEN REMOVING BATTERY NEGATIVE TERMINAL : Work Procedure

INFOID:000000008901492

1. SYSTEM INITIALIZATION

Perform system initialization. Refer to [ADP-68. "SYSTEM INITIALIZATION : Work Procedure"](#).

>> GO TO 2.

2. MEMORY STORAGE

Perform memory storage. Refer to [ADP-69. "MEMORY STORING : Work Procedure"](#).

>> GO TO 3.

3. INTELLIGENT KEY INTERLOCK STORAGE

Perform Intelligent Key interlock storage. Refer to [ADP-70. "INTELLIGENT KEY INTERLOCK STORING : Work Procedure"](#).

>> GO TO 4.

4. SYSTEM SETTING

Perform system setting. Refer to [ADP-70. "SYSTEM SETTING : Work Procedure"](#).

>> Inspection End.

ADDITIONAL SERVICE WHEN REPLACING CONTROL UNIT

ADDITIONAL SERVICE WHEN REPLACING CONTROL UNIT : Description

INFOID:000000008901493

Each function is reset to the following condition when the driver seat control unit is replaced.

Function	Condition	Procedure
Memory (Seat, steering, mirror)	Erased	Perform storing
Entry/exit assist	ON	Perform initialization
		Set slide amount* ¹

INSPECTION AND ADJUSTMENT

< BASIC INSPECTION >

Function	Condition	Procedure
Intelligent Key interlock	Erased	Perform initialization
		Perform storing

*1: Default value is 40 mm.

NOTE:

Notice that disconnecting the battery when detected DTC are present will erase the DTC memory.

ADDITIONAL SERVICE WHEN REPLACING CONTROL UNIT : Work Procedure

INFOID:000000008901494

1. SYSTEM INITIALIZATION

Perform system initialization. Refer to [ADP-68, "SYSTEM INITIALIZATION : Work Procedure"](#).

>> GO TO 2.

2. MEMORY STORAGE

Perform memory storage. Refer to [ADP-69, "MEMORY STORING : Work Procedure"](#).

>> GO TO 3.

3. INTELLIGENT KEY INTERLOCK STORAGE

Perform Intelligent Key interlock storage. Refer to [ADP-70, "INTELLIGENT KEY INTERLOCK STORING : Work Procedure"](#).

>> GO TO 4.

4. SYSTEM SETTING

Perform system setting. Refer to [ADP-70, "SYSTEM SETTING : Work Procedure"](#).

>> Inspection End.

SYSTEM INITIALIZATION

SYSTEM INITIALIZATION : Description

INFOID:000000008901495

Always perform the initialization when the battery terminal is disconnected or the driver seat control unit is replaced.

The entry/exit assist function will not operate normally if no initialization is performed.

SYSTEM INITIALIZATION : Work Procedure

INFOID:000000008901496

INITIALIZATION PROCEDURE

1. CHOOSE METHOD

There are two initialization methods.

Which method do you use?

With door switch >> GO TO 2.

With vehicle speed >> GO TO 4.

2. STEP A-1

Turn ignition switch from ACC to OFF position.

>> GO TO 3.

3. STEP A-2

Driver door switch is ON (open) → OFF (close) → ON (open).

INSPECTION AND ADJUSTMENT

< BASIC INSPECTION >

>> Inspection End.

4. STEP B-1

Drive the vehicle at more than 25 km/h (16 MPH).

>> Inspection End.

MEMORY STORING

MEMORY STORING : Description

INFOID:000000008901497

Always perform the memory storage when the battery terminal is disconnected or the driver seat control unit is replaced. The memory function will not operate normally if no memory storage is performed.

MEMORY STORING : Work Procedure

INFOID:000000008901498

Memory Storage Procedure

Two positions for the driver seat, steering column and outside mirror can be stored for memory operation by following procedure.

1. STEP 1

Check the following conditions.

- Ignition switch: ON
- CVT shift selector: P (Park) position

>> GO TO 2.

2. STEP 2

Adjust driver seat, steering column and outside mirror position manually.

>> GO TO 3.

3. STEP 3

1. Push set switch.

NOTE:

- Memory indicator for which driver seat position is already retained in memory is illuminated for 5 seconds.
- Memory indicator for which driver seat position is not retained in memory is illuminated for 0.5 seconds.

2. Push the memory switch (1 or 2) for at least 1 second within 5 seconds after pushing the set switch.

NOTE:

- To enter driver seat positions into blank memory, memory indicator will be turned on for 5 seconds.
- To modify driver seat positions, memory indicator will be turned OFF for 0.5 seconds, then turned ON for 5 seconds.

NOTE:

If memory is stored in the same memory switch, the previous memory will be deleted.

>> GO TO 4.

4. STEP 4

Confirm the operation of each part with memory operation.

>> Inspection End.

INTELLIGENT KEY INTERLOCK STORING

INTELLIGENT KEY INTERLOCK STORING : Description

INFOID:000000008901499

Always perform the Intelligent Key interlock function storage when the battery terminal is disconnected or the driver seat control unit is replaced. The Intelligent Key interlock function will not operate normally if no memory storage is performed.

A
B
C
D
E
F
G
H
I
K
L
M
N
O
P

ADP

INSPECTION AND ADJUSTMENT

< BASIC INSPECTION >

INTELLIGENT KEY INTERLOCK STORING : Work Procedure

INFOID:000000008901500

Intelligent Key Interlock Storage Procedure

Performing the following operation associates the registered driving position with Intelligent Key. When driver door unlock operation is performed by Intelligent Key or driver door request switch, display of the registered driving position and turnout operation can be performed.

1. STEP 1

Check the following conditions.

- Ignition switch: OFF
- Initialization: done
- Driving position: registered

>> GO TO 2.

2. STEP 2

1. Push set switch.

NOTE:

Memory indicator for which driver seat position is already retained in memory is illuminated for 5 seconds.

2. Push the Intelligent Key unlock button within 5 seconds after pushing memory switch (while the memory indicator is turned ON).

NOTE:

From the time registration is performed, the applicable memory indicator blinks for 5 seconds.

>> GO TO 3.

3. STEP 3

Confirm the operation of each part with memory operation and Intelligent Key interlock operation.

>> Inspection End.

SYSTEM SETTING

SYSTEM SETTING : Description

INFOID:000000008901501

The settings of the automatic driving positioner system can be changed, using CONSULT, the display unit in the center of the instrument panel and the set switch. Always check the settings before and after disconnecting the battery terminal or replacing driver seat control unit.

Setting Change

x: Applicable

Item	Content	CONSULT	Set switch	Factory setting
Amount of seat sliding for entry/exit assist	The amount of seat sliding for entry/exit assist can be selected from 3 items. [40 mm/80 mm/150 mm]	x	—	40 mm
Entry/exit assist (seat)	Entry/exit assist (seat) can be selected: ON (operated) – OFF (not operated)	x	x	ON
Entry/exit assist (steering column)	Entry/exit assist (steering column) can be selected: ON (operated) – OFF (not operated)	x		ON

SYSTEM SETTING : Work Procedure

INFOID:000000008901502

1. CHOOSE METHOD

There are three setting methods.

Which method do you choose?

With CONSULT>>GO TO 2.

INSPECTION AND ADJUSTMENT

< BASIC INSPECTION >

With set switch>>GO TO 4.

2. WITH CONSULT - STEP 1

Select "Work support".

>> GO TO 3.

3. WITH CONSULT - STEP 2

1. Select "EXIT SEAT SLIDE SETTING", or "EXIT TILT SETTING" then touch display to change between ON and OFF.
 - EXIT SEAT SLIDE SETTING: Entry/exit assist (seat)
 - EXIT TILT SETTING: Entry/exit assist (steering column)
2. Select "SEAT SLIDE VOLUME SET" and touch either of "40 mm", "80 mm", or "150 mm".
3. Then touch "OK".

>> Inspection End.

4. WITH SET SWITCH - STEP 1

Turn ignition switch OFF.

>> GO TO 5.

5. WITH SET SWITCH - STEP 2

Push set switch and hold for more than 10 seconds, then confirm blinking of the memory switch indicator.

- Entry/exit assist (seat/steering column) are ON: Memory switch indicator blink two times.
- Entry/exit assist (seat/steering column) are OFF: Memory switch indicator blink once.

>> Inspection End.

A
B
C
D
E
F
G
H
I
K
L
M
N
O
P

ADP

U1000 CAN COMM CIRCUIT

< DTC/CIRCUIT DIAGNOSIS >

DTC/CIRCUIT DIAGNOSIS

U1000 CAN COMM CIRCUIT

Description

INFOID:000000008901503

Refer to [LAN-36, "CAN COMMUNICATION SYSTEM : CAN Communication Signal Chart"](#).

DTC Logic

INFOID:000000008901504

DTC DETECTION LOGIC

DTC	Trouble diagnosis name	DTC detecting condition	Possible cause
U1000	CAN COMM CIRCUIT	<ul style="list-style-type: none">• Driver seat control unit cannot communicate to other control units.• Driver seat control unit cannot communicate for more than the specified time.	<ul style="list-style-type: none">• Harness or connectors (CAN communication line is open or shorted)

DTC CONFIRMATION PROCEDURE

1. STEP 1

Turn ignition switch ON and wait at least 3 seconds.

>> GO TO 2.

2. STEP 2

Check "Self diagnostic result" with CONSULT.

Is the DTC detected?

YES >> Perform diagnosis procedure. Refer to [ADP-72, "Diagnosis Procedure"](#).

NO >> Inspection End.

Diagnosis Procedure

INFOID:000000008901505

Refer to [LAN-20, "Trouble Diagnosis Flow Chart"](#).

Special Repair Requirement

INFOID:000000008901506

Refer to [ADP-68, "SYSTEM INITIALIZATION : Work Procedure"](#).

U1010 CONTROL UNIT (CAN)

< DTC/CIRCUIT DIAGNOSIS >

U1010 CONTROL UNIT (CAN)

Description

INFOID:000000008901507

Refer to [LAN-36. "CAN COMMUNICATION SYSTEM : CAN Communication Signal Chart"](#).

DTC Logic

INFOID:000000008901508

DTC DETECTION LOGIC

DTC No.	Trouble diagnosis name	DTC detecting condition	Possible cause
U1010	CONTROL UNIT (CAN)	When detecting error during the initial diagnosis of CAN controller of driver seat control unit.	<ul style="list-style-type: none">• Driver seat control unit

Diagnosis Procedure

INFOID:000000008901509

1. REPLACE DRIVER SEAT CONTROL UNIT

When DTC [U1010] is detected, replace driver seat control unit.

>> Replace driver seat control unit. Refer to [ADP-156. "Removal and Installation"](#).

A
B
C
D
E
F
G
H
I
K
L
M
N
O
P

ADP

B2112 SLIDING MOTOR

< DTC/CIRCUIT DIAGNOSIS >

B2112 SLIDING MOTOR

Description

INFOID:000000008901510

- The seat sliding motor LH is installed to the seat frame.
- The seat sliding motor LH is installed with the driver seat control unit.
- Slides the seat frontward/rearward by changing the rotation direction of sliding motor LH.

DTC Logic

INFOID:000000008901511

DTC DETECTION LOGIC

DTC No.	Trouble diagnosis name	DTC detecting condition	Possible cause
B2112	SEAT SLIDE	The driver seat control unit detects the output of sliding motor LH output terminal for 0.1 second or more even if the sliding switch is not input.	<ul style="list-style-type: none">• Driver seat control unit• Front power seat LH (sliding motor) harness is shorted

DTC CONFIRMATION PROCEDURE

1. PERFORM DTC CONFIRMATION PROCEDURE

1. Turn ignition switch ON.
2. Check "Self diagnostic result" with CONSULT.

Is the DTC detected?

- YES >> Refer to [ADP-74, "Diagnosis Procedure"](#).
NO >> Inspection End.

Diagnosis Procedure

INFOID:000000008901512

Regarding Wiring Diagram information, refer to [ADP-50, "WITH AROUND VIEW MONITOR : Wiring Diagram"](#) or [ADP-36, "WITHOUT AROUND VIEW MONITOR : Wiring Diagram"](#).

1. PERFORM DTC CONFIRMATION PROCEDURE

1. Turn ignition switch ON.
2. Check "Self diagnostic result" with CONSULT.
3. Erase the DTC.
4. Perform DTC confirmation procedure. Refer to [ADP-78, "DTC Logic"](#).

Is the DTC displayed again?

- YES >> GO TO 2.
NO >> Check intermittent incident. Refer to [GI-49, "Intermittent Incident"](#).

2. CHECK SLIDING MOTOR LH CIRCUIT (POWER SHORT)

1. Turn ignition switch OFF.
2. Disconnect sliding motor LH and driver seat control unit connector.
3. Check voltage between sliding motor LH harness connector and ground.

(+)		(-)	Voltage (V) (Approx.)
Sliding motor LH			
Connector	Terminals		
B211	4	Ground	0
	5		

Is the inspection result normal?

- YES >> GO TO 3.
NO >> Repair or replace harness or connector.

B2112 SLIDING MOTOR

< DTC/CIRCUIT DIAGNOSIS >

3. CHECK DRIVER SEAT CONTROL UNIT OUTPUT SIGNAL

1. Connect driver seat control unit connector.
2. Check voltage between driver seat control unit harness connector and ground.

(+)		(-)	Voltage (V) (Approx.)
Driver seat control unit			
Connector	Terminals	Ground	0
B210	36		
	44		

Is the inspection result normal?

YES >> GO TO 4.

NO >> Replace driver seat control unit. Refer to [ADP-156, "Removal and Installation"](#).

4. CHECK INTERMITTENT INCIDENT

Refer to [GI-49, "Intermittent Incident"](#).

>> Inspection End

A
B
C
D
E
F
G
H
I
K
L
M
N
O
P

ADP

B2113 RECLINING MOTOR

< DTC/CIRCUIT DIAGNOSIS >

B2113 RECLINING MOTOR

Description

INFOID:000000008901513

- The seat reclining motor LH is installed to the seatback assembly.
- The seat reclining motor LH is activated with the driver seat control unit.
- Tilts the seatback frontward/rearward by changing the rotation direction of reclining motor LH.

DTC Logic

INFOID:000000008901514

DTC DETECTION LOGIC

DTC No.	Trouble diagnosis name	DTC detecting condition	Possible cause
B2113	SEAT RECLINING	The driver seat control unit detects the output of reclining motor LH output terminal for 0.1 second or more even if the reclining switch is not input.	<ul style="list-style-type: none">• Driver seat control unit• Front power seat LH (reclining motor) harness is shorted

DTC CONFIRMATION PROCEDURE

1. PERFORM DTC CONFIRMATION PROCEDURE

1. Turn ignition switch ON.
2. Check "Self diagnostic result" with CONSULT.

Is the DTC detected?

- YES >> Refer to [ADP-76, "Diagnosis Procedure"](#).
NO >> Inspection End.

Diagnosis Procedure

INFOID:000000008901515

Regarding Wiring Diagram information, refer to [ADP-50, "WITH AROUND VIEW MONITOR : Wiring Diagram"](#) or [ADP-36, "WITHOUT AROUND VIEW MONITOR : Wiring Diagram"](#).

1. PERFORM DTC CONFIRMATION PROCEDURE

1. Turn ignition switch ON.
2. Check "Self diagnostic result" with CONSULT.
3. Erase the DTC.
4. Perform DTC confirmation procedure. Refer to [ADP-76, "DTC Logic"](#).

Is the DTC displayed again?

- YES >> GO TO 2.
NO >> Check intermittent incident. Refer to [GI-49, "Intermittent Incident"](#).

2. CHECK RECLINING MOTOR LH CIRCUIT (POWER SHORT)

1. Turn ignition switch OFF.
2. Disconnect reclining motor LH and driver seat control unit connector.
3. Check voltage between reclining motor LH harness connector and ground.

(+)		(-)	Voltage (V) (Approx.)
Reclining motor LH			
Connector	Terminals		
B217	4	Ground	0
	6		

Is the inspection result normal?

- YES >> GO TO 3.
NO >> Repair or replace harness or connector.

B2113 RECLINING MOTOR

< DTC/CIRCUIT DIAGNOSIS >

3. CHECK DRIVER SEAT CONTROL UNIT OUTPUT SIGNAL

1. Connect driver seat control unit connector.
2. Check voltage between driver seat control unit harness connector and ground.

(+)		(-)	Voltage (V) (Approx.)
Driver seat control unit			
Connector	Terminals	Ground	0
B210	35		
	39		

Is the inspection result normal?

YES >> GO TO 4.

NO >> Replace driver seat control unit. Refer to [ADP-156, "Removal and Installation"](#).

4. CHECK INTERMITTENT INCIDENT

Refer to [GI-49, "Intermittent Incident"](#).

>> Inspection End.

A
B
C
D
E
F
G
H
I
K
L
M
N
O
P

ADP

B2116 TILT MOTOR

< DTC/CIRCUIT DIAGNOSIS >

B2116 TILT MOTOR

Description

INFOID:000000008901516

- The tilt motor is installed to the steering column assembly.
- The tilt motor is activated with the automatic drive positioner control unit.
- The steering column is tilted up/down by changing the rotation direction tilt motor.

DTC Logic

INFOID:000000008901517

DTC DETECTION LOGIC

DTC No.	Trouble diagnosis name	DTC detecting condition	Possible cause
B2116	STEERING TILT	The automatic drive positioner control unit detects tilt motor operation for 0.1 second or more when tilt switch has not been turned on, and there is no output of automatic operation.	<ul style="list-style-type: none">• Automatic drive positioner control unit• Tilt motor harness is shorted

DTC CONFIRMATION PROCEDURE

1. PERFORM DTC CONFIRMATION PROCEDURE

1. Turn ignition switch ON.
2. Check "Self diagnostic result" with CONSULT.

Is the DTC detected?

- YES >> Refer to [ADP-78, "Diagnosis Procedure"](#).
NO >> Inspection End.

Diagnosis Procedure

INFOID:000000008901518

Regarding Wiring Diagram information, refer to [ADP-50, "WITH AROUND VIEW MONITOR : Wiring Diagram"](#) or [ADP-36, "WITHOUT AROUND VIEW MONITOR : Wiring Diagram"](#).

1. PERFORM DTC CONFIRMATION PROCEDURE

1. Turn ignition switch ON.
2. Check "Self diagnostic result" with CONSULT.
3. Erase the DTC.
4. Perform DTC confirmation procedure. Refer to [ADP-78, "DTC Logic"](#).

Is the DTC displayed again?

- YES >> GO TO 2.
NO >> Check intermittent incident. Refer to [GI-49, "Intermittent Incident"](#).

2. CHECK TILT MOTOR CIRCUIT (POWER SHORT)

1. Turn ignition switch OFF.
2. Disconnect automatic drive positioner control unit and tilt motor connector.
3. Check voltage between tilt motor harness connector and ground.

(+)		(-)	Voltage (V) (Approx.)
Tilt motor			
Connector	Terminals		
M85	1	Ground	0
	2		

Is the inspection result normal?

- YES >> GO TO 3.
NO >> Repair or replace harness or connector.

B2116 TILT MOTOR

< DTC/CIRCUIT DIAGNOSIS >

3. CHECK AUTOMATIC DRIVE POSITIONER CONTROL UNIT OUTPUT SIGNAL

1. Connect automatic drive positioner control unit connector.
2. Check voltage between automatic drive positioner control unit harness connector and ground.

(+)		(-)	Voltage (V) (Approx.)
Automatic drive positioner control unit			
Connector	Terminals	Ground	0
M34	28		
	29		

Is the inspection result normal?

- YES >> Check intermittent incident. Refer to [GI-49, "Intermittent Incident"](#)
NO >> Replace automatic drive positioner control unit. Refer to [ADP-157, "Removal and Installation"](#).

A
B
C
D
E
F
G
H
I
K
L
M
N
O
P

ADP

B2128 UART COMMUNICATION LINE

< DTC/CIRCUIT DIAGNOSIS >

B2128 UART COMMUNICATION LINE

Description

INFOID:000000008901519

Driver seat control unit performs UART communication with the automatic drive positioner control unit using 1 communication line. Driver seat control unit receives the operation signals of ADP steering switch, door mirror remote control switch and the position signals of tilt sensor, telescopic sensor and door mirror sensors from the automatic drive positioner control unit and transmits the operation request signal.

DTC Logic

INFOID:000000008901520

DTC DETECTION LOGIC

DTC No.	Trouble diagnosis name	DTC detecting condition	Possible cause
B2128	UART COMM	The communication between driver seat control unit and automatic drive positioner control unit is interrupted for a period of time.	<ul style="list-style-type: none">• UART communication line (UART communication line is open or shorted)• Driver seat control unit• Automatic drive positioner control unit

DTC CONFIRMATION PROCEDURE

1. PERFORM DTC CONFIRMATION PROCEDURE

1. Turn ignition switch ON.
2. Check "Self diagnostic result" with CONSULT.

Is the DTC detected?

- YES >> Refer to [ADP-80, "Diagnosis Procedure"](#).
NO >> Inspection End.

Diagnosis Procedure

INFOID:000000008901521

Regarding Wiring Diagram information, refer to [ADP-50, "WITH AROUND VIEW MONITOR : Wiring Diagram"](#) or [ADP-36, "WITHOUT AROUND VIEW MONITOR : Wiring Diagram"](#).

1. PERFORM DTC CONFIRMATION PROCEDURE

1. Turn ignition switch ON.
2. Check "Self diagnostic result" with CONSULT.
3. Erase the DTC.
4. Perform DTC confirmation procedure. Refer to [ADP-80, "DTC Logic"](#).

Is the DTC displayed again?

- YES >> GO TO 2.
NO >> Check intermittent incident. Refer to [GI-49, "Intermittent Incident"](#).

2. CHECK UART COMMUNICATION LINE CONTINUITY

1. Turn ignition switch OFF.
2. Disconnect driver seat control unit and automatic drive positioner control unit.
3. Check continuity between driver seat control unit harness connector and automatic drive positioner control unit harness connector.

Driver seat control unit		Automatic drive positioner control unit		Continuity
Connector	Terminal	Connector	Terminal	
B209	15	M33	8	Yes

4. Check continuity between driver seat control unit harness connector and ground.

B2128 UART COMMUNICATION LINE

< DTC/CIRCUIT DIAGNOSIS >

Driver seat control unit		Ground	Continuity
Connector	Terminal		
B209	15		No

Is the inspection result normal?

YES >> Check intermittent incident. Refer to [GI-49. "Intermittent Incident"](#).

NO >> Repair or replace harness.

A

B

C

D

E

F

G

H

I

ADP

K

L

M

N

O

P

B2130 EEPROM

< DTC/CIRCUIT DIAGNOSIS >

B2130 EEPROM

DTC Logic

INFOID:000000008901522

DTC DETECTION LOGIC

DTC No.	Trouble diagnosis name	DTC detecting condition	Possible cause
B2130	EEPROM	Driver seat control unit detected CPU malfunction.	• Driver seat control unit

DTC CONFIRMATION PROCEDURE

1. PERFORM DTC CONFIRMATION PROCEDURE

1. Turn ignition switch ON.
2. Check "Self diagnostic result" with CONSULT.

Is the DTC detected?

- YES >> Refer to [ADP-82, "Diagnosis Procedure"](#).
NO >> Inspection End.

Diagnosis Procedure

INFOID:000000008901523

1. PERFORM DTC CONFIRMATION PROCEDURE

1. Turn ignition switch ON.
2. Check "Self diagnostic result" with CONSULT.
3. Erase the DTC.
4. Perform DTC confirmation procedure. Refer to [ADP-82, "DTC Logic"](#).

Is the DTC displayed again?

- YES >> GO TO 2.
NO >> Check intermittent incident. Refer to [GI-49, "Intermittent Incident"](#).

2. REPLACE DRIVER SEAT CONTROL UNIT

Replace driver seat control unit. Refer to [ADP-156, "Removal and Installation"](#).

>> Inspection End.

POWER SUPPLY AND GROUND CIRCUIT

< DTC/CIRCUIT DIAGNOSIS >

POWER SUPPLY AND GROUND CIRCUIT

BCM

BCM : Diagnosis Procedure

INFOID:000000008945524

Regarding Wiring Diagram information, refer to [BCS-53, "Wiring Diagram"](#).

1. CHECK FUSE AND FUSIBLE LINK

Check that the following fuse and fusible link are not blown.

Terminal No.	Signal name	Fuse and fusible link No.
139	Fusible link battery power	O (40A)
131	BCM battery fuse	1 (10A)

Is the fuse or fusible link blown?

- YES >> Replace the blown fuse or fusible link after repairing the affected circuit.
NO >> GO TO 2

2. CHECK POWER SUPPLY CIRCUIT

1. Disconnect BCM connector M81.
2. Check voltage between BCM connector M81 terminals 131, 139 and ground.

BCM		Ground	Voltage (Approx.)
Connector	Terminal		
M81	131	—	Battery voltage
	139		

Is the inspection result normal?

- YES >> GO TO 3
NO >> Repair or replace harness or connectors.

3. CHECK GROUND CIRCUIT

Check continuity between BCM connector M81 terminals 134, 143 and ground.

BCM		Ground	Continuity
Connector	Terminal		
M81	134	—	Yes
	143		

Is the inspection result normal?

- YES >> Inspection End.
NO >> Repair or replace harness or connectors.

DRIVER SEAT CONTROL UNIT

DRIVER SEAT CONTROL UNIT : Diagnosis Procedure

INFOID:000000008901525

NOTE:

Do not disconnect the battery negative terminal and the driver seat control unit connector until DTC is confirmed with CONSULT.

Regarding Wiring Diagram information, refer to [ADP-50, "WITH AROUND VIEW MONITOR : Wiring Diagram"](#) or [ADP-36, "WITHOUT AROUND VIEW MONITOR : Wiring Diagram"](#).

POWER SUPPLY AND GROUND CIRCUIT

< DTC/CIRCUIT DIAGNOSIS >

1. CHECK POWER SUPPLY CIRCUIT

1. Turn ignition switch OFF.
2. Disconnect driver seat control unit.
3. Check voltage between driver seat control unit harness connector and ground.

(+)		(-)	Power source	Condition	Voltage (V) (Approx.)
Connector	Terminal				
B210	37	Ground	Battery power supply	Ignition switch OFF	Battery voltage

Is the inspection result normal?

- YES >> GO TO 2.
NO >> Check the following.
- Repair or replace harness.
 - Circuit breaker-2.

2. CHECK GROUND CIRCUIT

Check continuity between the driver seat control unit harness connector and ground.

Driver seat control unit		Ground	Continuity
Connector	Terminal		
B210	39		Yes

Is the inspection result normal?

- YES >> Inspection End.
NO >> Repair or replace harness.

DRIVER SEAT CONTROL UNIT : Special Repair Requirement

INFOID:000000008901526

1.PERFORM ADDITIONAL SERVICE

Perform additional service when removing battery negative terminal.

>> Refer to [ADP-67, "ADDITIONAL SERVICE WHEN REMOVING BATTERY NEGATIVE TERMINAL : Description"](#).

AUTOMATIC DRIVE POSITIONER CONTROL UNIT

AUTOMATIC DRIVE POSITIONER CONTROL UNIT : Diagnosis Procedure

INFOID:000000008901527

NOTE:

Do not disconnect the battery negative terminal and the driver seat control unit connector until DTC is confirmed with CONSULT.

Regarding Wiring Diagram information, refer to [ADP-50, "WITH AROUND VIEW MONITOR : Wiring Diagram"](#) or [ADP-36, "WITHOUT AROUND VIEW MONITOR : Wiring Diagram"](#).

1. CHECK POWER SUPPLY CIRCUIT

1. Turn ignition switch OFF.
2. Disconnect automatic drive positioner control unit.
3. Check voltage between automatic drive positioner control unit harness connector and ground.

POWER SUPPLY AND GROUND CIRCUIT

< DTC/CIRCUIT DIAGNOSIS >

(+)		(-)	Voltage (V) (Approx.)
Automatic drive positioner control unit			
Connector	Terminal		
M34	25	Ground	Battery voltage

Is the inspection result normal?

YES >> GO TO 2.

NO >> Check the following.

- Repair or replace harness.
- Circuit breaker.

2. CHECK GROUND CIRCUIT

Check continuity between the automatic drive positioner control unit harness connector and ground.

Automatic drive positioner control unit		Ground	Continuity
Connector	Terminal		
M34	30		Yes

Is the inspection result normal?

YES >> Inspection End.

NO >> Repair or replace harness.

AUTOMATIC DRIVE POSITIONER CONTROL UNIT : Special Repair Requirement

INFOID:000000008901528

1. PERFORM ADDITIONAL SERVICE

Perform additional service when removing battery negative terminal.

>> Refer to [ADP-67. "ADDITIONAL SERVICE WHEN REMOVING BATTERY NEGATIVE TERMINAL : Description"](#).

ADP

SLIDING SWITCH

< DTC/CIRCUIT DIAGNOSIS >

SLIDING SWITCH

Description

INFOID:000000008901529

Sliding switch is equipped to the power seat switch LH on the seat frame. The operation signal is input to the driver seat control unit when the sliding switch is operated.

Component Function Check

INFOID:000000008901530

1. CHECK FUNCTION

1. Select "SLIDE SW-FR", "SLIDE SW-RR" in "DATA MONITOR" mode with CONSULT.
2. Check sliding switch signal under the following conditions.

Monitor item	Condition	Status	
SLIDE SW-FR	Sliding switch (forward)	Operate	ON
		Release	OFF
SLIDE SW-RR	Sliding switch (backward)	Operate	ON
		Release	OFF

Is the inspection result normal?

YES >> Inspection End.

NO >> Perform diagnosis procedure. Refer to [ADP-86, "Diagnosis Procedure"](#).

Diagnosis Procedure

INFOID:000000008901531

Regarding Wiring Diagram information, refer to [ADP-50, "WITH AROUND VIEW MONITOR : Wiring Diagram"](#) or [ADP-36, "WITHOUT AROUND VIEW MONITOR : Wiring Diagram"](#).

1. CHECK SLIDING SWITCH SIGNAL

1. Turn ignition switch OFF.
2. Check voltage between driver seat control unit harness connector and ground.

(+) Driver seat control unit		(-)	Condition	Voltage (V) (Approx.)
Connector	Terminals			
B209	9	Ground	Operate (backward)	0
			Release	Battery voltage
	25		Operate (forward)	0
			Release	Battery voltage

Is the inspection result normal?

YES >> GO TO 5.

NO >> GO TO 2.

2. CHECK SLIDING SWITCH CIRCUIT

1. Turn ignition switch OFF.
2. Disconnect driver seat control unit and power seat switch LH.
3. Check continuity between driver seat control unit harness connector and power seat switch LH harness connector.

SLIDING SWITCH

< DTC/CIRCUIT DIAGNOSIS >

Driver seat control unit		Power seat switch LH		Continuity
Connector	Terminal	Connector	Terminal	
B209	9	B208	8	Yes
	25		7	

4. Check continuity between driver seat control unit harness connector and ground.

Driver seat control unit connector		Ground	Continuity
Connector	Terminal		
B209	9		No
	25		

Is the inspection result normal?

YES >> GO TO 3.

NO >> Repair or replace harness.

3. CHECK DRIVER SEAT CONTROL UNIT OUTPUT

1. Connect the driver seat control unit.
2. Turn ignition switch ON.
3. Check voltage between driver seat control unit harness connector and ground.

(+) Driver seat control unit		(-)	Voltage (V) (Approx.)
Connector	Terminals		
B209	9	Ground	Battery voltage
	25		

Is the inspection result normal?

YES >> GO TO 4.

NO >> Replace driver seat control unit. Refer to [ADP-156, "Removal and Installation"](#).

4. CHECK SLIDING SWITCH

Refer to [ADP-87, "Component Inspection"](#).

Is the inspection result normal?

YES >> GO TO 5.

NO >> Replace power seat switch LH. Refer to [ADP-159, "Removal and Installation"](#).

5. CHECK INTERMITTENT INCIDENT

Refer to [GI-49, "Intermittent Incident"](#).

Is the inspection result normal?

YES >> Replace driver seat control unit. Refer to [ADP-156, "Removal and Installation"](#).

NO >> Repair or replace malfunctioning part.

Component Inspection

INFOID:000000008901532

1. CHECK SLIDING SWITCH

1. Turn ignition switch OFF.
2. Disconnect power seat switch LH.
3. Check continuity between power seat switch LH terminals.

SLIDING SWITCH

< DTC/CIRCUIT DIAGNOSIS >

Terminal		Condition	Continuity	
Power seat switch LH				
3	8	Sliding switch (backward)	Operate	Yes
			Release	No
	7	Sliding switch (forward)	Operate	Yes
			Release	No

Is the inspection result normal?

YES >> Inspection End.

NO >> Replace power seat switch LH. Refer to [ADP-159, "Removal and Installation"](#).

RECLINING SWITCH

< DTC/CIRCUIT DIAGNOSIS >

RECLINING SWITCH

Description

INFOID:000000008901533

Reclining switch is equipped to the power seat switch LH on the seat frame. The operation signal is input to the driver seat control unit when the reclining switch is operated.

Component Function Check

INFOID:000000008901534

1. CHECK FUNCTION

1. Select "RECLN SW-FR", "RECLN SW-RR" in "DATA MONITOR" mode with CONSULT.
2. Check reclining switch signal under the following conditions.

Monitor item	Condition	Status	
RECLN SW-FR	Reclining switch (forward)	Operate	ON
		Release	OFF
RECLN SW-RR	Reclining switch (backward)	Operate	ON
		Release	OFF

Is the inspection result normal?

- YES >> Inspection End.
NO >> Perform diagnosis procedure. Refer to [ADP-89, "Diagnosis Procedure"](#).

Diagnosis Procedure

INFOID:000000008901535

Regarding Wiring Diagram information, refer to [ADP-50, "WITH AROUND VIEW MONITOR : Wiring Diagram"](#) or [ADP-36, "WITHOUT AROUND VIEW MONITOR : Wiring Diagram"](#).

1. CHECK RECLINING SWITCH SIGNAL

ADP

1. Turn ignition switch OFF.
2. Check voltage between driver seat control unit harness connector and ground.

(+) Driver seat control unit		(-)	Condition	Voltage (V) (Approx.)
Connector	Terminals			
B209	24	Ground	Operate (forward)	0
			Release	Battery voltage
	8		Operate (backward)	0
			Release	Battery voltage

Is the inspection result normal?

- YES >> GO TO 5.
NO >> GO TO 2.

2. CHECK RECLINING SWITCH CIRCUIT

1. Turn ignition switch OFF.
2. Disconnect driver seat control unit and power seat switch LH.
3. Check continuity between driver seat control unit harness connector and power seat switch LH harness connector.

RECLINING SWITCH

< DTC/CIRCUIT DIAGNOSIS >

Driver seat control unit		Power seat switch LH connector		Continuity
Connector	Terminal	Connector	Terminal	
B209	24	B208	9	Yes
	8		10	

4. Check continuity between driver seat control unit harness connector and ground.

Driver seat control unit		Ground	Continuity
Connector	Terminal		
B209	24		No
	8		

Is the inspection result normal?

YES >> GO TO 3.

NO >> Repair or replace harness.

3. CHECK DRIVER SEAT CONTROL UNIT OUTPUT

1. Connect the driver seat control unit.
2. Turn ignition switch ON.
3. Check voltage between driver seat control unit harness connector and ground.

(+)		(-)	Voltage (V) (Approx.)
Driver seat control unit			
Connector	Terminals	Ground	Battery voltage
B209	8		
	24		

Is the inspection result normal?

YES >> GO TO 4.

NO >> Replace driver seat control unit. Refer to [ADP-156, "Removal and Installation"](#).

4. CHECK RECLINING SWITCH

Refer to [ADP-90, "Component Inspection"](#).

Is the inspection result normal?

YES >> GO TO 5.

NO >> Replace power seat switch LH. Refer to [ADP-159, "Removal and Installation"](#).

5. CHECK INTERMITTENT INCIDENT

Refer to [GI-49, "Intermittent Incident"](#).

Is the inspection result normal?

YES >> Replace driver seat control unit. Refer to [ADP-156, "Removal and Installation"](#).

NO >> Repair or replace the malfunctioning part.

Component Inspection

INFOID:000000008901536

1. CHECK RECLINING SWITCH

1. Turn ignition switch OFF.
2. Disconnect power seat switch LH.
3. Check continuity between power seat switch LH terminals.

RECLINING SWITCH

< DTC/CIRCUIT DIAGNOSIS >

Terminals		Condition		Continuity
Power seat switch LH				
3	10	Reclining switch (backward)	Operate	Yes
			Release	No
	9	Reclining switch (forward)	Operate	Yes
			Release	No

Is the inspection result normal?

YES >> Inspection End.

NO >> Replace power seat switch LH. Refer to [ADP-159, "Removal and Installation"](#).

A
B
C
D
E
F
G
H
I
K
L
M
N
O
P

ADP

LIFTING SWITCH (FRONT)

< DTC/CIRCUIT DIAGNOSIS >

LIFTING SWITCH (FRONT)

Description

INFOID:000000008901537

Lifting switch (front) is equipped to the power seat switch LH on the seat frame. The operation signal is input to the driver seat control unit when the lifting switch (front) is operated.

Component Function Check

INFOID:000000008901538

1. CHECK FUNCTION

1. Select "LIFT FR SW-UP", "LIFT FR SW-DN" in "DATA MONITOR" mode with CONSULT.
2. Check lifting switch (front) signal under the following conditions.

Monitor item	Condition		Status
LIFT FR SW-UP	Lifting switch front (up)	Operate	ON
		Release	OFF
LIFT FR SW-DN	Lifting switch front (down)	Operate	ON
		Release	OFF

Is the inspection result normal?

YES >> Inspection End.

NO >> Perform diagnosis procedure. Refer to [ADP-92, "Diagnosis Procedure"](#).

Diagnosis Procedure

INFOID:000000008901539

Regarding Wiring Diagram information, refer to [ADP-50, "WITH AROUND VIEW MONITOR : Wiring Diagram"](#) or [ADP-36, "WITHOUT AROUND VIEW MONITOR : Wiring Diagram"](#).

1. CHECK LIFTING SWITCH SIGNAL

1. Turn ignition switch OFF.
2. Check voltage between driver seat control unit harness connector and ground.

(+)		(-)	Condition	Voltage (V) (Approx.)
Driver seat control unit Connector	Terminals			
B209	7	Ground	Operate (down)	0V
			Release	Battery voltage
	23		Operate (up)	0V
			Release	Battery voltage

Is the inspection result normal?

YES >> GO TO 5.

NO >> GO TO 2.

2. CHECK LIFTING SWITCH (FRONT) CIRCUIT

1. Turn ignition switch OFF.
2. Disconnect driver seat control unit and power seat switch LH.
3. Check continuity between driver seat control unit harness connector and power seat switch LH harness connector.

LIFTING SWITCH (FRONT)

< DTC/CIRCUIT DIAGNOSIS >

Driver seat control unit		Power seat switch LH		Continuity
Connector	Terminal	Connector	Terminal	
B209	7	B208	6	Yes
	23		5	

4. Check continuity between driver seat control unit harness connector and ground.

Driver seat control unit		Ground	Continuity
Connector	Terminal		
B209	7		No
	23		

Is the inspection result normal?

YES >> GO TO 3.

NO >> Repair or replace harness.

3. CHECK DRIVER SEAT CONTROL UNIT OUTPUT

1. Connect the driver seat control unit.
2. Turn ignition switch ON.
3. Check voltage between driver seat control unit harness connector and ground.

(+)		(-)	Voltage (V) (Approx.)
Driver seat control unit			
Connector	Terminals	Ground	Battery voltage
B209	7		
	23		

Is the inspection result normal?

YES >> GO TO 4.

NO >> Replace driver seat control unit. Refer to [ADP-156, "Removal and Installation"](#).

4. CHECK LIFTING SWITCH (FRONT)

Refer to [ADP-93, "Component Inspection"](#).

Is the inspection result normal?

YES >> GO TO 5.

NO >> Replace power seat switch LH. Refer to [ADP-159, "Removal and Installation"](#).

5. CHECK INTERMITTENT INCIDENT

Refer to [GI-49, "Intermittent Incident"](#).

Is the inspection result normal?

YES >> Replace driver seat control unit. Refer to [ADP-156, "Removal and Installation"](#).

NO >> Repair or replace the malfunctioning part.

Component Inspection

INFOID:000000008901540

1. CHECK LIFTING SWITCH (FRONT)

1. Turn ignition switch OFF.
2. Disconnect power seat switch LH.
3. Check continuity between power seat switch LH terminals.

LIFTING SWITCH (FRONT)

< DTC/CIRCUIT DIAGNOSIS >

Terminal		Condition	Continuity	
Power seat switch LH				
3	6	Lifting switch front (down)	Operate	Yes
			Release	No
	5	Lifting switch front (up)	Operate	Yes
			Release	No

Is the inspection result normal?

YES >> Inspection End.

NO >> Replace power seat switch LH. Refer to [ADP-159, "Removal and Installation"](#).

LIFTING SWITCH (REAR)

< DTC/CIRCUIT DIAGNOSIS >

LIFTING SWITCH (REAR)

Description

INFOID:000000008901541

Lifting switch (rear) is equipped to the power seat switch LH on the seat frame. The operation signal is inputted to the driver seat control unit when the lifting switch (rear) is operated.

Component Function Check

INFOID:000000008901542

1. CHECK FUNCTION

1. Select "LIFT RR SW-UP", "LIFT RR SW-DN" in "DATA MONITOR" mode with CONSULT.
2. Check lifting switch (rear) signal under the following conditions.

Monitor item	Condition		Status
LIFT RR SW-UP	Lifting switch rear (up)	Operate	ON
		Release	OFF
LIFT RR SW-DN	Lifting switch rear (down)	Operate	ON
		Release	OFF

Is the inspection result normal?

YES >> Inspection End.

NO >> Perform diagnosis procedure. Refer to [ADP-95, "Diagnosis Procedure"](#).

Diagnosis Procedure

INFOID:000000008901543

Regarding Wiring Diagram information, refer to [ADP-50, "WITH AROUND VIEW MONITOR : Wiring Diagram"](#) or [ADP-36, "WITHOUT AROUND VIEW MONITOR : Wiring Diagram"](#).

1. CHECK LIFTING SWITCH (REAR) SIGNAL

1. Turn ignition switch OFF.
2. Check voltage between driver seat control unit harness connector and ground.

(+)		(-)	Condition	Voltage (V) (Approx.)
Driver seat control unit Connector	Terminals			
B209	6	Ground	Lifting switch (rear) Operate (down)	0
			Release	Battery voltage
	22		Operate (up)	0
			Release	Battery voltage

Is the inspection result normal?

YES >> GO TO 5.

NO >> GO TO 2.

2. CHECK LIFTING SWITCH (REAR) CIRCUIT

1. Turn ignition switch OFF.
2. Disconnect driver seat control unit and power seat switch LH.
3. Check continuity between driver seat control unit harness connector and power seat switch LH harness connector.

LIFTING SWITCH (REAR)

< DTC/CIRCUIT DIAGNOSIS >

Driver seat control unit		Power seat switch LH		Continuity
Connector	Terminal	Connector	Terminal	
B209	6	B208	2	Yes
	22		1	

4. Check continuity between driver seat control unit harness connector and ground.

Driver seat control unit		Ground	Continuity
Connector	Terminal		
B209	6		No
	22		

Is the inspection result normal?

YES >> GO TO 3.

NO >> Repair or replace harness.

3. CHECK DRIVER SEAT CONTROL UNIT OUTPUT

1. Connect the driver seat control unit.
2. Turn ignition switch ON.
3. Check voltage between driver seat control unit harness connector and ground.

(+)		(-)	Voltage (V) (Approx.)
Driver seat control unit			
Connector	Terminals		
B209	6	Ground	Battery voltage
	22		

Is the inspection result normal?

YES >> GO TO 4.

NO >> Replace driver seat control unit. Refer to [ADP-156, "Removal and Installation"](#).

4. CHECK LIFTING SWITCH (REAR)

Refer to [ADP-96, "Component Inspection"](#).

Is the inspection result normal?

YES >> GO TO 5.

NO >> Replace power seat switch LH. Refer to [ADP-159, "Removal and Installation"](#).

5. CHECK INTERMITTENT INCIDENT

Refer to [GI-49, "Intermittent Incident"](#).

Is the inspection result normal?

YES >> Replace driver seat control unit. Refer to [ADP-156, "Removal and Installation"](#).

NO >> Repair or replace the malfunctioning part.

Component Inspection

INFOID:000000008901544

1. CHECK LIFTING SWITCH (REAR)

1. Turn ignition switch OFF.
2. Disconnect power seat switch LH.
3. Check continuity between power seat switch LH terminals.

LIFTING SWITCH (REAR)

< DTC/CIRCUIT DIAGNOSIS >

Terminal		Condition	Continuity	
Power seat switch LH				
3	1	Lifting switch rear (up)	Operate	Yes
			Release	No
	2	Lifting switch rear (down)	Operate	Yes
			Release	No

Is the inspection result normal?

YES >> Inspection End.

NO >> Replace power seat switch LH. Refer to [ADP-159, "Removal and Installation"](#).

A
B
C
D
E
F
G
H
I
K
L
M
N
O
P

ADP

TILT SWITCH

< DTC/CIRCUIT DIAGNOSIS >

TILT SWITCH

Description

INFOID:000000008901545

ADP steering switch (tilt switch) is equipped to the steering column. The operation signal is input to the automatic drive positioner control unit when the ADP steering switch is operated.

Component Function Check

INFOID:000000008901546

1. CHECK FUNCTION

1. Select "TILT SW-UP", "TILT SW-DOWN" in "DATA MONITOR" mode with CONSULT.
2. Check tilt switch signal under the following conditions.

Monitor item	Condition		Status
TILT SW-UP	Tilt switch (up)	Operate	ON
		Release	OFF
TILT SW-DOWN	Tilt switch (down)	Operate	ON
		Release	OFF

Is the inspection result normal?

YES >> Inspection End.

NO >> Perform diagnosis procedure. Refer to [ADP-98, "Diagnosis Procedure"](#).

Diagnosis Procedure

INFOID:000000008901547

Regarding Wiring Diagram information, refer to [ADP-50, "WITH AROUND VIEW MONITOR : Wiring Diagram"](#) or [ADP-36, "WITHOUT AROUND VIEW MONITOR : Wiring Diagram"](#).

1. CHECK TILT SWITCH SIGNAL

1. Disconnect ADP steering switch (tilt switch).
2. Check voltage between ADP steering switch harness connector and ground.

(+)		(-)	Voltage (V) (Approx.)
Connector	Terminals		
M16	2	Ground	Battery voltage
	5		

Is the inspection result normal?

YES >> GO TO 3.

NO >> GO TO 2.

2. CHECK TILT SWITCH CIRCUIT

1. Disconnect automatic drive positioner control unit.
2. Check continuity between automatic drive positioner control unit harness connector and ADP steering switch harness connector.

Automatic drive positioner control unit		ADP steering switch (tilt switch)		Continuity
Connector	Terminal	Connector	Terminal	
M33	1	M16	5	Yes
	13		2	

3. Check continuity between automatic drive positioner control unit harness connector and ground.

TILT SWITCH

< DTC/CIRCUIT DIAGNOSIS >

Automatic drive positioner control unit		Ground	Continuity
Connector	Terminal		
M33	1		No
	13		

Is the inspection result normal?

- YES >> Replace automatic drive positioner unit. Refer to [ADP-157, "Removal and Installation"](#).
 NO >> Repair or replace harness.

3. CHECK TILT SWITCH

Refer to [ADP-99, "Component Inspection"](#).

Is the inspection result normal?

- YES >> GO TO 4.
 NO >> Replace ADP steering switch (tilt switch). Refer to [ADP-160, "Removal and Installation"](#).

4. CHECK INTERMITTENT INCIDENT

Refer to [GI-49, "Intermittent Incident"](#).

>> Inspection End.

Component Inspection

INFOID:000000008901548

1. CHECK TILT SWITCH

- Turn ignition switch OFF.
- Disconnect ADP steering switch (tilt switch).
- Check continuity between ADP steering switch terminals.

ADP steering switch (tilt switch)		Condition	Continuity	
Terminal				
3	5	Tilt switch (up)	Operate	Yes
			Release	No
	2	Tilt switch (down)	Operate	Yes
			Release	No

Is the inspection result normal?

- YES >> Inspection End.
 NO >> Replace ADP steering switch (tilt switch). Refer to [ADP-160, "Removal and Installation"](#).

A
B
C
D
E
F
G
H
I
K
L
M
N
O
P

ADP

TELESCOPIC SWITCH

< DTC/CIRCUIT DIAGNOSIS >

TELESCOPIC SWITCH

Description

INFOID:000000008901549

ADP steering switch (telescopic switch) is equipped to the steering column. The operation signal is input to the automatic drive positioner control unit when the telescopic switch is operated.

Component Function Check

INFOID:000000008901550

1. CHECK FUNCTION

1. Select "TELESCO SW-FR", "TELESCO SW-RR" in "DATA MONITOR" mode with CONSULT.
2. Check telescopic switch signal under the following conditions.

Monitor item	Condition		Status
TELESCO SW-FR	Telescopic switch (forward)	Operate	ON
		Release	OFF
TELESCO SW-RR	Telescopic switch (backward)	Operate	ON
		Release	OFF

Is the inspection result normal?

YES >> Inspection End.

NO >> Perform diagnosis procedure. Refer to [ADP-100, "Diagnosis Procedure"](#).

Diagnosis Procedure

INFOID:000000008901551

Regarding Wiring Diagram information, refer to [ADP-50, "WITH AROUND VIEW MONITOR : Wiring Diagram"](#) or [ADP-36, "WITHOUT AROUND VIEW MONITOR : Wiring Diagram"](#).

1. CHECK TELESCOPIC SWITCH SIGNAL

1. Disconnect ADP steering switch (telescopic switch).
2. Check voltage between ADP steering switch harness connector and ground.

(+)		(-)	Voltage (V) (Approx.)
Connector	Terminals		
M16	1	Ground	Battery voltage
	6		

Is the inspection result normal?

YES >> GO TO 3.

NO >> GO TO 2.

2. CHECK TELESCOPIC SWITCH CIRCUIT

1. Disconnect automatic drive positioner control unit.
2. Check continuity between automatic drive positioner control unit harness connector and ADP steering switch harness connector.

Automatic drive positioner control unit		ADP steering switch (telescopic switch)		Continuity
Connector	Terminal	Connector	Terminal	
M33	7	M16	1	Yes
	19		6	

3. Check continuity between automatic drive positioner control unit harness connector and ground.

TELESCOPIC SWITCH

< DTC/CIRCUIT DIAGNOSIS >

Automatic drive positioner control unit		Ground	Continuity
Connector	Terminal		
M33	7		No
	19		

Is the inspection result normal?

- YES >> Replace automatic drive positioner unit. Refer to [ADP-157, "Removal and Installation"](#).
 NO >> Repair or replace harness.

3. CHECK TELESCOPIC SWITCH

Refer to [ADP-101, "Component Inspection"](#).

Is the inspection result normal?

- YES >> GO TO 4.
 NO >> Replace ADP steering switch (telescopic switch). Refer to [ADP-160, "Removal and Installation"](#).

4. CHECK INTERMITTENT INCIDENT

Refer to [GI-49, "Intermittent Incident"](#).

>> Inspection End.

Component Inspection

INFOID:000000008901552

1. CHECK TELESCOPIC SWITCH

- Turn ignition switch OFF.
- Disconnect ADP steering switch (telescopic switch).
- Check continuity between ADP steering switch terminals.

ADP steering switch (telescopic switch)		Condition	Continuity	
Terminal				
3	1	Telescopic switch (forward)	Operate	Yes
			Release	No
	6	Telescopic switch (backward)	Operate	Yes
			Release	No

Is the inspection result normal?

- YES >> Inspection End.
 NO >> Replace ADP steering switch (telescopic switch). Refer to [ADP-160, "Removal and Installation"](#).

A
B
C
D
E
F
G
H
I
K
L
M
N
O
P

ADP

SEAT MEMORY SWITCH

< DTC/CIRCUIT DIAGNOSIS >

SEAT MEMORY SWITCH

Description

INFOID:000000008901553

Seat memory switch is installed to the front door LH trim. The operation signal is input to the driver seat control unit when the memory switch is operated.

Component Function Check

INFOID:000000008901554

1. CHECK FUNCTION

1. Select "MEMORY SW 1", "MEMORY SW 2", "SET SW" in "DATA MONITOR" mode with CONSULT.
2. Check seat memory switch signal under the following conditions.

Monitor item	Condition	Status	
MEMORY SW 1	Memory switch 1	Push	ON
		Release	OFF
MEMORY SW 2	Memory switch 2	Push	ON
		Release	OFF
SET SW	Set switch	Push	ON
		Release	OFF

Is the inspection result normal?

YES >> Inspection End.

NO >> Perform diagnosis procedure. Refer to [ADP-102. "Diagnosis Procedure"](#).

Diagnosis Procedure

INFOID:000000008901555

Regarding Wiring Diagram information, refer to [ADP-50. "WITH AROUND VIEW MONITOR : Wiring Diagram"](#) or [ADP-36. "WITHOUT AROUND VIEW MONITOR : Wiring Diagram"](#).

1. CHECK SEAT MEMORY SWITCH SIGNAL

1. Turn ignition switch OFF.
2. Disconnect seat memory switch.
3. Turn ignition switch ON.
4. Check voltage between seat memory switch harness connector and ground.

(+)		(-)	Voltage (V) (Approx.)		
Seat memory switch					
Connector	Terminals	Ground	5		
D60	2			Ground	5
	10				
	16				

Is the inspection result normal?

YES >> GO TO 3.

NO >> GO TO 2.

2. CHECK MEMORY SWITCH CIRCUIT

1. Turn ignition switch OFF.
2. Disconnect driver seat control unit.
3. Check continuity between driver seat control unit harness connector and seat memory switch harness connector.

SEAT MEMORY SWITCH

< DTC/CIRCUIT DIAGNOSIS >

Driver seat control unit		Seat memory switch		Continuity
Connector	Terminal	Connector	Terminal	
B209	11	D60	16	Yes
	21		2	
	27		10	

4. Check continuity between driver seat control unit harness connector and ground.

Driver seat control unit		Ground	Continuity
Connector	Terminal		
B209	11	Ground	No
	21		
	27		

Is the inspection result normal?

YES >> Replace driver seat control unit. Refer to [ADP-156, "Removal and Installation"](#).

NO >> Repair or replace harness.

3. CHECK MEMORY SWITCH GROUND CIRCUIT

Check continuity between seat memory switch harness connector and ground.

Seat memory switch		Ground	Continuity
Connector	Terminal		
D60	9	Ground	Yes

Is the inspection result normal?

YES >> GO TO 4.

NO >> Repair or replace harness.

4. CHECK SEAT MEMORY SWITCH

Refer to [ADP-103, "Component Inspection"](#).

Is the inspection result normal?

YES >> Check intermittent incident. Refer to [GI-49, "Intermittent Incident"](#).

NO >> Replace seat memory switch. Refer to [ADP-158, "Removal and Installation"](#).

Component Inspection

INFOID:000000008901556

1. CHECK SEAT MEMORY SWITCH

1. Turn ignition switch OFF.
2. Disconnect seat memory switch.
3. Check continuity between seat memory switch terminals.

Terminal		Condition	Continuity	
Seat memory switch				
9	10	Memory switch 1	Push	Yes
			Release	No
	16	Memory switch 2	Push	Yes
			Release	No
	2	Set switch	Push	Yes
			Release	No

Is the inspection result normal?

YES >> Inspection End.

A
B
C
D
E
F
G
H
I
K
L
M
N
O
P

ADP

SEAT MEMORY SWITCH

< DTC/CIRCUIT DIAGNOSIS >

NO >> Replace seat memory switch. Refer to [ADP-158, "Removal and Installation"](#).

DOOR MIRROR REMOTE CONTROL SWITCH

< DTC/CIRCUIT DIAGNOSIS >

DOOR MIRROR REMOTE CONTROL SWITCH CHANGEOVER SWITCH

CHANGEOVER SWITCH : Description

INFOID:000000008901557

Changeover switch is integrated into door mirror remote control switch.
Changeover switch has three positions (L, N and R).
It changes door mirror motor operation by transmitting control signal to automatic drive positioner control unit.

CHANGEOVER SWITCH : Component Function Check

INFOID:000000008901558

1. CHECK FUNCTION

1. Select "MIR CHNG SW-R", "MIR CHNG SW-L" in "DATA MONITOR" mode with CONSULT.
2. Check changeover switch signal under the following conditions.

Monitor item	Condition	Status	
MIR CHNG SW-R	Mirror switch (right)	Operate	ON
		Release	OFF
MIR CHNG SW-L	Mirror switch (left)	Operate	ON
		Release	OFF

Is the inspection result normal?

- YES >> Inspection End.
NO >> Perform diagnosis procedure. Refer to [ADP-105, "CHANGEOVER SWITCH : Diagnosis Procedure"](#).

CHANGEOVER SWITCH : Diagnosis Procedure

INFOID:000000008901559

Regarding Wiring Diagram information, refer to [ADP-50, "WITH AROUND VIEW MONITOR : Wiring Diagram"](#) or [ADP-36, "WITHOUT AROUND VIEW MONITOR : Wiring Diagram"](#).

1. CHECK CHANGEOVER SWITCH SIGNAL

1. Turn ignition switch ON.
2. Check voltage between automatic drive positioner control unit connector and ground.

(+)		(-)	Change over switch condition	Voltage (V) (Approx.)
Automatic drive positioner control unit	Connector			
M33	2	Ground	RIGHT	0
			Other than above	5
	14		LEFT	0
			Other than above	5

Is the inspection result normal?

- YES >> GO TO 5.
NO >> GO TO 2.

2. CHECK HARNESS CONTINUITY

1. Turn ignition switch OFF.
2. Disconnect automatic drive positioner control unit and door mirror remote control switch.
3. Check continuity between automatic drive positioner control unit connector and door mirror remote control switch connector.

DOOR MIRROR REMOTE CONTROL SWITCH

< DTC/CIRCUIT DIAGNOSIS >

Automatic drive positioner control unit		Door mirror remote control switch		Continuity
Connector	Terminal	Connector	Terminal	
M33	2	D22	3	Yes
	14		4	

4. Check continuity between automatic drive positioner control unit connector and ground.

Automatic drive positioner control unit		Ground	Continuity
Connector	Terminal		
M33	2		No
	14		

Is the inspection result normal?

YES >> GO TO 3.

NO >> Repair or replace harness.

3. CHECK DOOR MIRROR REMOTE CONTROL SWITCH GROUND CIRCUIT

Check continuity between door mirror remote control switch connector and ground.

Door mirror remote control switch		Ground	Continuity
Connector	Terminal		
D22	15		Yes

Is the inspection result normal?

YES >> GO TO 4.

NO >> Repair or replace harness.

4. CHECK CHANGEOVER SWITCH

Check changeover switch.

Refer to [ADP-106, "CHANGEOVER SWITCH : Component Inspection"](#).

Is the inspection result normal?

YES >> Refer to [GI-49, "Intermittent Incident"](#).

NO >> Replace door mirror remote control switch. Refer to [MIR-22, "Removal and Installation"](#).

5. CHECK INTERMITTENT INCIDENT

Check intermittent incident.

Refer to [GI-49, "Intermittent Incident"](#).

Is the inspection result normal?

YES >> Replace automatic drive positioner control unit. Refer to [ADP-157, "Removal and Installation"](#).

NO >> Repair or replace the malfunctioning parts.

CHANGEOVER SWITCH : Component Inspection

INFOID:000000008901560

1. CHECK CHANGEOVER SWITCH

Check door mirror remote control switch.

Terminal		Change over switch condition	Continuity
Door mirror remote control switch			
3	15	LEFT	Yes
		Other than above	No
4		RIGHT	Yes
		Other than above	No

DOOR MIRROR REMOTE CONTROL SWITCH

< DTC/CIRCUIT DIAGNOSIS >

Is the inspection result normal?

YES >> Inspection End.

NO >> Replace door mirror remote control switch. Refer to [MIR-22, "Removal and Installation"](#).

MIRROR SWITCH

MIRROR SWITCH : Description

INFOID:000000008901561

It operates angle of the door mirror face.

It transmits mirror face adjust operation to automatic drive positioner control unit.

MIRROR SWITCH : Component Function Check

INFOID:000000008901562

1. CHECK FUNCTION

1. Select "MIR CON SW-UP/DN", "MIR CON SW-RH/LH" in "DATA MONITOR" mode with CONSULT.

2. Check mirror switch signal under the following conditions.

Monitor item	Condition		Status
MIR CON SW-UP/DN	Mirror switch (up/down)	Operate	ON
		Release	OFF
MIR CON SW-RH/LH	Mirror switch (right/left)	Operate	ON
		Release	OFF

Is the inspection result normal?

YES >> Inspection End.

NO >> Perform diagnosis procedure. Refer to [ADP-107, "MIRROR SWITCH : Diagnosis Procedure"](#).

MIRROR SWITCH : Diagnosis Procedure

INFOID:000000008901563

Regarding Wiring Diagram information, refer to [ADP-50, "WITH AROUND VIEW MONITOR : Wiring Diagram"](#) or [ADP-36, "WITHOUT AROUND VIEW MONITOR : Wiring Diagram"](#).

ADP

1. CHECK MIRROR SWITCH FUNCTION

1. Turn ignition switch ON.

2. Check voltage between automatic drive positioner control unit connector and ground.

(+) Automatic drive positioner control unit		(-)	Mirror switch Condition	Voltage (V) (Approx.)
Connector	Terminal			
M33	3	Ground	UP	0
			Other than above	5
	4		LEFT	0
			Other than above	5
	15		DOWN	0
			Other than above	5
	16		RIGHT	0
			Other than above	5

Is the inspection result normal?

YES >> GO TO 5.

NO >> GO TO 2.

2. CHECK HARNESS CONTINUITY

DOOR MIRROR REMOTE CONTROL SWITCH

< DTC/CIRCUIT DIAGNOSIS >

1. Turn ignition switch OFF.
2. Disconnect automatic drive positioner control unit and door mirror remote control switch.
3. Check continuity between automatic drive positioner control unit connector and door mirror remote control switch connector.

Automatic drive positioner control unit		Door mirror remote control switch		Continuity
Connector	Terminal	Connector	Terminal	
M33	3	D22	12	Yes
	4		1	
	15		16	
	16		9	

4. Check continuity between automatic drive positioner control unit connector and ground.

Automatic drive positioner control unit		Ground	Continuity
Connector	Terminal		
M33	3	Ground	No
	4		
	15		
	16		

Is the inspection result normal?

YES >> GO TO 3.

NO >> Repair or replace harness.

3. CHECK DOOR MIRROR REMOTE CONTROL SWITCH GROUND CIRCUIT

Check continuity between door mirror remote control switch connector and ground.

Door mirror remote control switch		Ground	Continuity
Connector	Terminal		
D22	15		Yes

Is the inspection result normal?

YES >> GO TO 4.

NO >> Repair or replace harness.

4. CHECK MIRROR SWITCH

Check mirror switch.

Refer to [ADP-108, "MIRROR SWITCH : Component Inspection"](#).

Is the inspection result normal?

YES >> Refer to [GI-49, "Intermittent Incident"](#).

NO >> Replace door mirror remote control switch. Refer to [MIR-22, "Removal and Installation"](#).

5. CHECK INTERMITTENT INCIDENT

Check intermittent incident.

Refer to [GI-49, "Intermittent Incident"](#).

Is the inspection result normal?

YES >> Replace automatic drive positioner control unit. Refer to [ADP-157, "Removal and Installation"](#).

NO >> Repair or replace the malfunctioning parts.

MIRROR SWITCH : Component Inspection

INFOID:000000008901564

1. CHECK MIRROR SWITCH

Check door mirror remote control switch.

DOOR MIRROR REMOTE CONTROL SWITCH

< DTC/CIRCUIT DIAGNOSIS >

Terminal		Mirror switch condition	Continuity
Door mirror remote control switch			
9	15	RIGHT	Yes
		Other than above	No
1		LEFT	Yes
		Other than above	No
12		UP	Yes
		Other than above	No
16		DOWN	Yes
		Other than above	No

Is the inspection result normal?

YES >> Inspection End.

NO >> Replace door mirror remote control switch. Refer to [MIR-22, "Removal and Installation"](#).

A
B
C
D
E
F
G
H
I
K
L
M
N
O
P

ADP

POWER SEAT SWITCH GROUND CIRCUIT

< DTC/CIRCUIT DIAGNOSIS >

POWER SEAT SWITCH GROUND CIRCUIT

Diagnosis Procedure

INFOID:000000008901565

Regarding Wiring Diagram information, refer to [ADP-50, "WITH AROUND VIEW MONITOR : Wiring Diagram"](#) or [ADP-36, "WITHOUT AROUND VIEW MONITOR : Wiring Diagram"](#).

1. CHECK POWER SEAT SWITCH LH GROUND CIRCUIT

1. Turn ignition switch OFF.
2. Disconnect power seat switch LH.
3. Check continuity between power seat switch LH connector and ground.

Power seat switch LH		Ground	Continuity
Connector	Terminal		
B208	3		Yes

Is the inspection result normal?

- YES >> Check intermittent incident. Refer to [GI-49, "Intermittent Incident"](#).
NO >> Repair or replace harness.

TILT & TELESCOPIC SWITCH GROUND CIRCUIT

< DTC/CIRCUIT DIAGNOSIS >

TILT & TELESCOPIC SWITCH GROUND CIRCUIT

Diagnosis Procedure

INFOID:000000008901566

Regarding Wiring Diagram information, refer to [ADP-50, "WITH AROUND VIEW MONITOR : Wiring Diagram"](#) or [ADP-36, "WITHOUT AROUND VIEW MONITOR : Wiring Diagram"](#).

1. CHECK ADP STEERING SWITCH (TILT & TELESCOPIC SWITCH) GROUND CIRCUIT

1. Turn ignition switch OFF.
2. Disconnect ADP steering switch (tilt & telescopic switch).
3. Check continuity between ADP steering switch (tilt & telescopic switch) and ground.

ADP steering switch (tilt & telescopic switch)		Ground	Continuity
Connector	Terminal		
M16	3		Yes

Is the inspection result normal?

- YES >> Check intermittent incident. Refer to [GI-49, "Intermittent Incident"](#).
NO >> Repair or replace harness.

A
B
C
D
E
F
G
H
I
K
L
M
N
O
P

ADP

SLIDING SENSOR

< DTC/CIRCUIT DIAGNOSIS >

SLIDING SENSOR

Description

INFOID:000000008901567

- The sliding sensor is installed to the seat frame.
- The pulse signal is input to the driver seat control unit when sliding is performed.
- The driver seat control unit counts the pulse and calculates the sliding amount of the seat.

Component Function Check

INFOID:000000008901568

1. CHECK FUNCTION

1. Select "SLIDE PULSE" in "DATA MONITOR" mode with CONSULT.
2. Check sliding sensor switch signal under the following conditions.

Monitor item	Condition		Value
SLIDE PULSE	Seat sliding	Operate (forward)	Change (decrease)
		Operate (backward)	Change (increase)
		Release	No change

Is the inspection result normal?

YES >> Inspection End.

NO >> Perform diagnosis procedure. Refer to [ADP-112, "Diagnosis Procedure"](#).

Diagnosis Procedure

INFOID:000000008901569

Regarding Wiring Diagram information, refer to [ADP-50, "WITH AROUND VIEW MONITOR : Wiring Diagram"](#) or [ADP-36, "WITHOUT AROUND VIEW MONITOR : Wiring Diagram"](#).

1. CHECK SLIDING SENSOR SIGNAL

1. Turn ignition switch ON.
2. Read voltage signal between driver seat control unit harness connector and ground with oscilloscope.

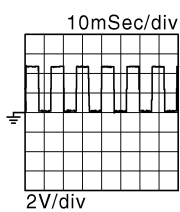
(+)		(-)	Condition	Voltage signal
Driver's seat control unit				
Connector	Terminal			
B209	31	Ground	Seat sliding	 <p>10mSec/div</p> <p>2V/div</p> <p>JMJIA0119ZZ</p>
			Operate	
			Other than above	0 or 5

Is the inspection result normal?

YES >> Replace driver seat control unit. Refer to [ADP-156, "Removal and Installation"](#).

NO >> GO TO 2.

2. CHECK SLIDING SENSOR CIRCUIT

1. Turn ignition switch OFF.
2. Disconnect driver seat control unit and sliding motor LH.

SLIDING SENSOR

< DTC/CIRCUIT DIAGNOSIS >

3. Check continuity between driver seat control unit harness connector and sliding motor LH harness connector.

Driver seat control unit		Sliding motor LH		Continuity
Connector	Terminal	Connector	Terminal	
B209	31	B211	2	Yes

4. Check continuity between driver seat control unit harness connector and ground.

Driver seat control unit		Ground	Continuity
Connector	Terminal		
B209	31		No

Is the inspection result normal?

YES >> GO TO 3.

NO >> Repair or replace harness.

3. CHECK SLIDING SENSOR POWER SUPPLY

1. Connect driver seat control unit.
2. Turn ignition switch ON.
3. Check voltage between sliding motor LH harness connector and ground.

(+)		(-)	Voltage (V) (Approx.)
Sliding motor LH			
Connector	Terminals		
B211	3	Ground	Battery voltage

Is the inspection result normal?

YES >> GO TO 5.

NO >> GO TO 4.

4. CHECK SLIDING SENSOR POWER SUPPLY CIRCUIT

1. Turn ignition switch OFF.
2. Disconnect driver seat control unit.
3. Check continuity between driver seat control unit harness connector and sliding motor LH harness connector.

Driver seat control unit		Sliding motor LH		Continuity
Connector	Terminal	Connector	Terminal	
B209	5	B211	3	Yes

4. Check continuity between driver seat control unit harness connector and ground.

Driver seat control unit		Ground	Continuity
Connector	Terminal		
B209	5		No

Is the inspection result normal?

YES >> Replace driver seat control unit. Refer to [ADP-156, "Removal and Installation"](#).

NO >> Repair or replace harness.

5. CHECK SLIDING SENSOR GROUND

1. Turn ignition switch OFF.
2. Check continuity between sliding motor LH harness connector and ground.

A
B
C
D
E
F
G
H
I
K
L
M
N
O
P

ADP

SLIDING SENSOR

< DTC/CIRCUIT DIAGNOSIS >

Sliding motor LH		Ground	Continuity
Connector	Terminal		
B211	1		Yes

Is the inspection result normal?

- YES >> Replace sliding motor LH. Refer to [SE-85. "Removal and Installation"](#).
- NO >> Repair or replace harness.

RECLINING SENSOR

< DTC/CIRCUIT DIAGNOSIS >

RECLINING SENSOR

Description

INFOID:000000008901570

- The reclining motor LH is installed to the seatback assembly.
- The pulse signal is input to the driver seat control unit when the reclining is operated.
- The driver seat control unit counts the pulse and calculates the reclining amount of the seat.

Component Function Check

INFOID:000000008901571

1. CHECK FUNCTION

1. Select "RECLN PULSE" in "DATA MONITOR" mode with CONSULT.
2. Check reclining sensor signal under the following conditions.

Monitor item	Condition		Value
RECLN PULSE	Seat reclining	Operate (forward)	Change (decrease)
		Operate (backward)	Change (increase)
		Release	No change

Is the inspection result normal?

YES >> Inspection End.

NO >> Perform diagnosis procedure. Refer to [ADP-115, "Diagnosis Procedure"](#).

Diagnosis Procedure

INFOID:000000008901572

Regarding Wiring Diagram information, refer to [ADP-50, "WITH AROUND VIEW MONITOR : Wiring Diagram"](#) or [ADP-36, "WITHOUT AROUND VIEW MONITOR : Wiring Diagram"](#).

1. CHECK RECLINING SENSOR SIGNAL

1. Turn ignition switch ON.
2. Read voltage signal between driver seat control unit harness connector and ground with oscilloscope.

(+)		(-)	Condition	Voltage signal
Driver seat control unit				
Connector	Terminal			
B209	13	Ground	Seat reclining	<p>10mSec/div</p> <p>2V/div</p> <p>JMJIA0119ZZ</p>
			Operate	
			Other than above	0 or 5

Is the inspection result normal?

YES >> Replace driver seat control unit. Refer to [ADP-156, "Removal and Installation"](#).

NO >> GO TO 2.

2. CHECK RECLINING SENSOR CIRCUIT

1. Turn ignition switch OFF.
2. Disconnect driver seat control unit and reclining motor LH.

A
B
C
D
E
F
G
H
I
K
L
M
N
O
P

ADP

RECLINING SENSOR

< DTC/CIRCUIT DIAGNOSIS >

3. Check continuity between driver seat control unit harness connector and reclining motor LH harness connector.

Driver seat control unit		Reclining motor LH		Continuity
Connector	Terminal	Connector	Terminal	
B209	13	B217	1	Yes

4. Check continuity between driver seat control unit harness connector and ground.

Driver seat control unit		Ground	Continuity
Connector	Terminal		
B209	13		No

Is the inspection result normal?

YES >> GO TO 3.

NO >> Repair or replace harness.

3. CHECK RECLINING SENSOR POWER SUPPLY

1. Connect driver seat control unit.
2. Turn ignition switch ON.
3. Check voltage between reclining motor LH harness connector and ground.

(+)		(-)	Voltage (V) (Approx.)
Reclining motor LH			
Connector	Terminals		
B217	3	Ground	Battery voltage

Is the inspection result normal?

YES >> GO TO 5.

NO >> GO TO 4.

4. CHECK RECLINING SENSOR POWER SUPPLY CIRCUIT

1. Turn ignition switch OFF.
2. Disconnect driver seat control unit.
3. Check continuity between driver seat control unit harness connector and reclining motor LH harness connector.

Driver seat control unit		Reclining motor LH		Continuity
Connector	Terminal	Connector	Terminal	
B209	5	B217	3	Yes

4. Check continuity between driver seat control unit harness connector and ground.

Driver seat control unit		Ground	Continuity
Connector	Terminal		
B209	5		No

Is the inspection result normal?

YES >> Replace driver seat control unit. Refer to [ADP-156, "Removal and Installation"](#).

NO >> Repair or replace harness.

5. CHECK RECLINING SENSOR GROUND

1. Turn ignition switch OFF.
2. Check continuity between reclining motor LH harness connector and ground.

RECLINING SENSOR

< DTC/CIRCUIT DIAGNOSIS >

Reclining motor LH		Ground	Continuity
Connector	Terminal		
B217	2		Yes

Is the inspection result normal?

YES >> Replace reclining motor LH. Refer to [SE-85. "Removal and Installation"](#).

NO >> Repair or replace harness.

A
B
C
D
E
F
G
H
I
K
L
M
N
O
P

ADP

LIFTING SENSOR (FRONT)

< DTC/CIRCUIT DIAGNOSIS >

LIFTING SENSOR (FRONT)

Description

INFOID:000000008901573

- The lifting sensor (front) is installed to the seat frame.
- The pulse signal is input to the driver seat control unit when the lifting (front) is operated.
- The driver seat control unit counts the pulse and calculates the lifting (front) amount of the seat.

Component Function Check

INFOID:000000008901574

1. CHECK FUNCTION

1. Select "LIFT FR PULSE" in "DATA MONITOR" mode with CONSULT.
2. Check the lifting sensor (front) signal under the following conditions.

Monitor item	Condition		Value
LIFT FR PULSE	Seat lifting (front)	Operate (up)	Change (decrease)
		Operate (down)	Change (increase)
		Release	No change

Is the inspection result normal?

YES >> Inspection End.

NO >> Perform diagnosis procedure. Refer to [ADP-118, "Diagnosis Procedure"](#).

Diagnosis Procedure

INFOID:000000008901575

Regarding Wiring Diagram information, refer to [ADP-50, "WITH AROUND VIEW MONITOR : Wiring Diagram"](#) or [ADP-36, "WITHOUT AROUND VIEW MONITOR : Wiring Diagram"](#).

1. CHECK LIFTING SENSOR (FRONT) SIGNAL

1. Turn ignition switch ON.
2. Read the voltage signal between driver seat control unit harness connector and ground with an oscilloscope.

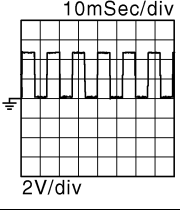
(+)		(-)	Condition	Voltage signal
Connector	Terminal			
B209	30	Ground	Seat lifting (front)	 <p>10mSec/div 2V/div JMJA0119ZZ</p>
			Operate	
			Other than above	0 or 5

Is the inspection result normal?

YES >> GO TO 4.

NO >> GO TO 2.

2. CHECK LIFTING SENSOR (FRONT) CIRCUIT

1. Turn ignition switch OFF.
2. Disconnect driver seat control unit and lifting motor LH (front).
3. Check continuity between driver seat control unit harness connector and lifting motor LH (front) harness connector.

LIFTING SENSOR (FRONT)

< DTC/CIRCUIT DIAGNOSIS >

Driver seat control unit		Lifting motor LH (front)		Continuity
Connector	Terminal	Connector	Terminal	
B209	30	B218	1	Yes

4. Check continuity between driver seat control unit harness connector and ground.

Driver seat control unit		Ground	Continuity
Connector	Terminal		
B209	30		No

Is the inspection result normal?

YES >> GO TO 3.

NO >> Repair or replace harness.

3. CHECK LIFTING SENSOR (FRONT) POWER SUPPLY

1. Connect driver seat control unit.
2. Turn ignition switch ON.
3. Check voltage between lifting motor LH (front) harness connector and ground.

(+)		(-)	Voltage (V) (Approx.)
Lifting motor LH (front)			
Connector	Terminals		
B218	3	Ground	Battery voltage

Is the inspection result normal?

YES >> GO TO 5.

NO >> GO TO 4.

4. CHECK LIFTING SENSOR (FRONT) POWER SUPPLY CIRCUIT

1. Turn ignition switch OFF.
2. Disconnect driver seat control unit.
3. Check continuity between driver seat control unit harness connector and lifting motor LH (front) harness connector.

Driver seat control unit		Lifting motor LH (front)		Continuity
Connector	Terminal	Connector	Terminal	
B209	5	B218	3	Yes

4. Check continuity between driver seat control unit harness connector and ground.

Driver seat control unit		Ground	Continuity
Connector	Terminal		
B209	5		No

Is the inspection result normal?

YES >> Replace driver seat control unit. Refer to [ADP-156, "Removal and Installation"](#).

NO >> Repair or replace harness.

5. CHECK LIFTING SENSOR (FRONT) GROUND

1. Turn ignition switch OFF.
2. Check continuity between lifting motor LH (front) harness connector and ground.

Lifting motor LH (front)		Ground	Continuity
Connector	Terminal		
B218	2		Yes

A
B
C
D
E
F
G
H
I
K
L
M
N
O
P

ADP

LIFTING SENSOR (FRONT)

< DTC/CIRCUIT DIAGNOSIS >

Is the inspection result normal?

- YES >> Replace lifting motor LH (front). Refer to [SE-85, "Removal and Installation"](#).
- NO >> Repair or replace harness.

LIFTING SENSOR (REAR)

< DTC/CIRCUIT DIAGNOSIS >

LIFTING SENSOR (REAR)

Description

INFOID:000000008901576

- The lifting sensor (rear) is installed to the seat frame.
- The pulse signal is input to the driver seat control unit when the lifting (rear) is operated.
- The driver seat control unit counts the pulse and calculates the lifting (rear) amount of the seat.

Component Function Check

INFOID:000000008901577

1. CHECK FUNCTION

1. Select "LIFT RR PULSE" in " mode with CONSULT.
2. Check lifting sensor (rear) signal under the following conditions.

Monitor item	Condition		Value
LIFT RR PULSE	Seat lifting (rear)	Operate (up)	Change (decrease)
		Operate (down)	Change (increase)
		Release	No change

Is the inspection result normal?

- YES >> Inspection End.
 NO >> Perform diagnosis procedure. Refer to [ADP-121, "Diagnosis Procedure"](#).

Diagnosis Procedure

INFOID:000000008901578

Regarding Wiring Diagram information, refer to [ADP-50, "WITH AROUND VIEW MONITOR : Wiring Diagram"](#) or [ADP-36, "WITHOUT AROUND VIEW MONITOR : Wiring Diagram"](#).

1. CHECK LIFTING SENSOR (REAR) SIGNAL

ADP

1. Turn ignition switch ON.
2. Read voltage signal between driver seat control unit harness connector and ground with oscilloscope.

(+)		(-)	Condition	Voltage signal
Driver seat control unit				
Connec-tor	Termi-nal			
B209	29	Ground	Seat lifting (rear)	
			Other than above	0 or 5

Is the inspection result normal?

- YES >> Replace driver seat control unit. Refer to [ADP-156, "Removal and Installation"](#).
 NO >> GO TO 2.

2. CHECK LIFTING SENSOR (REAR) CIRCUIT

1. Turn ignition switch OFF.
2. Disconnect driver seat control unit and lifting motor LH (rear).

LIFTING SENSOR (REAR)

< DTC/CIRCUIT DIAGNOSIS >

3. Check the continuity between driver seat control unit harness connector and lifting motor LH (rear) harness connector.

Driver seat control unit		Lifting motor LH (rear)		Continuity
Connector	Terminal	Connector	Terminal	
B209	29	B207	1	Yes

4. Check the continuity between driver seat control unit harness connector and ground.

Driver seat control unit		Ground	Continuity
Connector	Terminal		
B209	29		No

Is the inspection result normal?

YES >> GO TO 3.

NO >> Repair or replace harness.

3. CHECK LIFTING SENSOR (REAR) POWER SUPPLY

1. Connect driver seat control unit.
2. Turn ignition switch ON.
3. Check the voltage between lifting motor LH (rear) harness connector and ground.

(+)		(-)	Voltage (V) (Approx.)
Lifting motor LH (rear)			
Connector	Terminals		
B207	3	Ground	Battery voltage

Is the inspection result normal?

YES >> GO TO 5.

NO >> GO TO 4.

4. CHECK LIFTING SENSOR (REAR) POWER SUPPLY CIRCUIT

1. Turn ignition switch OFF.
2. Disconnect driver seat control unit.
3. Check the continuity between driver seat control unit harness connector and lifting motor LH (rear) harness connector.

Driver seat control unit		Lifting motor LH (rear)		Continuity
Connector	Terminal	Connector	Terminal	
B209	5	B207	3	Yes

4. Check the continuity between driver seat control unit harness connector and ground.

Driver seat control unit		Ground	Continuity
Connector	Terminal		
B209	5		No

Is the inspection result normal?

YES >> Replace driver seat control unit. Refer to [ADP-156, "Removal and Installation"](#).

NO >> Repair or replace harness.

5. CHECK LIFTING SENSOR (REAR) GROUND

1. Turn ignition switch OFF.
2. Check the continuity between lifting motor LH (rear) harness connector and ground.

LIFTING SENSOR (REAR)

< DTC/CIRCUIT DIAGNOSIS >

Lifting motor LH (rear)		Ground	Continuity
Connector	Terminal		
B207	2		Yes

Is the inspection result normal?

YES >> Replace lifting motor LH (rear). Refer to [SE-85. "Removal and Installation"](#).

NO >> Repair or replace harness.

A

B

C

D

E

F

G

H

I

ADP

K

L

M

N

O

P

TILT SENSOR

< DTC/CIRCUIT DIAGNOSIS >

TILT SENSOR

Description

INFOID:000000008901579

- The tilt sensor is installed to the steering column assembly.
- The pulse signal is input to the driver seat control unit when the tilt is operated.
- The driver seat control unit counts the pulse and calculates the tilt amount of the steering column.

Component Function Check

INFOID:000000008901580

1. CHECK FUNCTION

1. Select "TILT PULSE" in "DATA MONITOR" mode with CONSULT.
2. Check tilt sensor signal under the following conditions.

Monitor item	Condition		Value
TILT PULSE	Steering column	Operate (UP-WARD)	Change (decrease)
		Operate (DOWN-WARD)	Change (increase)
		Release	No change

Is the inspection result normal?

- YES >> Inspection End.
 NO >> Perform diagnosis procedure. Refer to [ADP-124. "Diagnosis Procedure"](#).

Diagnosis Procedure

INFOID:000000008901581

Regarding Wiring Diagram information, refer to [ADP-50. "WITH AROUND VIEW MONITOR : Wiring Diagram"](#) or [ADP-36. "WITHOUT AROUND VIEW MONITOR : Wiring Diagram"](#).

1. CHECK TILT SENSOR SIGNAL

1. Turn ignition switch ON.
2. Check voltage signal between driver seat control unit connector and ground with oscilloscope.

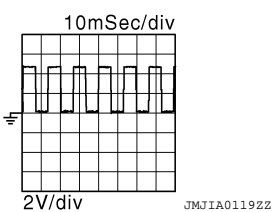
(+)		(-)	Condition	Voltage (V) (Approx.)
Driver seat control unit	Con-connector			
	Terminals			
B209	28	Ground	Steering column	 <p>10mSec/div 2V/div JMJA0119ZZ</p>
			Other than above	0 or 5

Is the inspection result normal?

- YES >> Replace driver seat control unit. Refer to [ADP-156. "Removal and Installation"](#).
 NO >> GO TO 2.

2. CHECK TILT SENSOR CIRCUIT

1. Turn ignition switch OFF.
2. Disconnect driver seat control unit and tilt motor.

TILT SENSOR

< DTC/CIRCUIT DIAGNOSIS >

3. Check continuity between driver seat control unit harness connector and tilt motor harness connector.

Driver seat control unit		Tilt motor		Continuity
Connector	Terminal	Connector	Terminal	
B209	28	M85	4	Yes

4. Check continuity between driver seat control unit harness connector and ground.

Driver seat control unit		Ground	Continuity
Connector	Terminal		
B209	28		No

Is the inspection result normal?

YES >> GO TO 3.

NO >> Repair or replace harness.

3. CHECK TILT SENSOR POWER SUPPLY

1. Connect driver seat control unit.
2. Turn ignition switch ON.
3. Check voltage between tilt motor harness connector and ground.

(+)		(-)	Voltage (V) (Approx.)
Tilt motor			
Connector	Terminals		
M85	5	Ground	Battery voltage

Is the inspection result normal?

YES >> GO TO 5.

NO >> GO TO 4.

4. CHECK TILT SENSOR POWER SUPPLY CIRCUIT

1. Turn ignition switch OFF.
2. Disconnect automatic drive positioner control unit.
3. Check continuity between automatic drive positioner control unit harness connector and tilt motor harness connector.

Automatic drive positioner control unit		Tilt motor		Continuity
Connector	Terminal	Connector	Terminal	
M34	27	M85	5	Yes

4. Check continuity between automatic drive positioner control unit harness connector and ground.

Automatic drive positioner control unit		Ground	Continuity
Connector	Terminal		
M34	27		No

Is the inspection result normal?

YES >> Replace automatic drive positioner control unit. Refer to [ADP-157, "Removal and Installation"](#).

NO >> Repair or replace harness or connector.

5. CHECK TILT SENSOR GROUND CIRCUIT

1. Turn ignition switch OFF.
2. Disconnect automatic drive positioner control unit.
3. Check continuity between automatic drive positioner control unit harness connector and tilt motor harness connector.

A
B
C
D
E
F
G
H
I
K
L
M
N
O
P

ADP

TILT SENSOR

< DTC/CIRCUIT DIAGNOSIS >

Automatic drive positioner control unit		Tilt motor		Continuity
Connector	Terminal	Connector	Terminal	
M33	20	M85	3	Yes

Is the inspection result normal?

- YES >> Replace tilt motor. Refer to [ST-46. "Exploded View"](#).
NO >> Repair or replace harness.

TELESCOPIC SENSOR

< DTC/CIRCUIT DIAGNOSIS >

TELESCOPIC SENSOR

Description

INFOID:000000008901582

- The telescopic sensor is installed to the steering column assembly.
- The pulse signal is input to the driver seat control unit when telescopic is performed.
- The driver seat control unit counts the pulse and calculates the telescopic amount of the steering column.

Component Function Check

INFOID:000000008901583

1. CHECK FUNCTION

1. Select "TELESCO PULSE" in "DATA MONITOR" mode with CONSULT.
2. Check telescopic sensor signal under the following conditions.

Monitor item	Condition		Valve
TELESCO PULSE	Steering column	Operate (forward)	Change (decrease)
		Operate (backward)	Change (increase)
		Release	No change

Is the inspection result normal?

- YES >> Inspection End.
 NO >> Perform diagnosis procedure. Refer to [ADP-127, "Diagnosis Procedure"](#).

Diagnosis Procedure

INFOID:000000008901584

Regarding Wiring Diagram information, refer to [ADP-50, "WITH AROUND VIEW MONITOR : Wiring Diagram"](#) or [ADP-36, "WITHOUT AROUND VIEW MONITOR : Wiring Diagram"](#).

1. CHECK TELESCOPIC SENSOR SIGNAL

ADP

1. Turn ignition switch ON.
2. Check voltage signal between driver seat control unit connector and ground with oscilloscope.

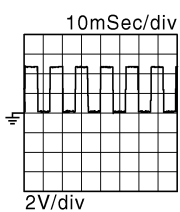
(+)		(-)	Condition	Voltage (V) (Approx.)
Driver seat control unit				
Con- nector	Termi- nals			
B209	12	Ground	Steering column	
			Operate	
			Other than above	0 or 5

Is the inspection result normal?

- YES >> Replace driver seat control unit. Refer to [ADP-156, "Removal and Installation"](#).
 NO >> GO TO 2.

2. CHECK TELESCOPIC SENSOR CIRCUIT

1. Turn ignition switch OFF.
2. Disconnect driver seat control unit and telescopic motor.

TELESCOPIC SENSOR

< DTC/CIRCUIT DIAGNOSIS >

3. Check continuity between driver seat control unit harness connector and telescopic motor harness connector.

Driver seat control unit		Telescopic motor		Continuity
Connector	Terminal	Connector	Terminal	
B209	12	M94	4	Yes

4. Check continuity between driver seat control unit harness connector and ground.

Driver seat control unit		Ground	Continuity
Connector	Terminal		
B209	12		No

Is the inspection result normal?

YES >> GO TO 3.

NO >> Repair or replace harness.

3. CHECK TELESCOPIC SENSOR POWER SUPPLY

1. Connect driver seat control unit.
2. Turn ignition switch ON.
3. Check voltage between telescopic motor harness connector and ground.

(+)		(-)	Voltage (V) (Approx.)
Telescopic motor			
Connector	Terminals		
M94	5	Ground	Battery voltage

Is the inspection result normal?

YES >> GO TO 5.

NO >> GO TO 4.

4. CHECK TELESCOPIC SENSOR POWER SUPPLY CIRCUIT

1. Turn ignition switch OFF.
2. Disconnect automatic drive positioner control unit.
3. Check continuity between automatic drive positioner control unit harness connector and telescopic motor harness connector.

Automatic drive positioner control unit		Telescopic motor		Continuity
Connector	Terminal	Connector	Terminal	
M34	27	M94	5	Yes

4. Check continuity between automatic drive positioner control unit harness connector and ground.

Automatic drive positioner control unit		Ground	Continuity
Connector	Terminal		
M34	27		No

Is the inspection result normal?

YES >> Replace automatic drive positioner control unit. Refer to [ADP-157. "Removal and Installation"](#).

NO >> Repair or replace harness.

5. CHECK TELESCOPIC SENSOR GROUND CIRCUIT

1. Turn ignition switch OFF.
2. Disconnect automatic drive positioner control unit.
3. Check continuity between automatic drive positioner control unit harness connector and telescopic motor harness connector.

TELESCOPIC SENSOR

< DTC/CIRCUIT DIAGNOSIS >

Automatic drive positioner control unit		Telescopic motor		Continuity
Connector	Terminal	Connector	Terminal	
M33	20	M94	3	Yes

Is the inspection result normal?

- YES >> Replace telescopic motor. Refer to [ST-46, "Exploded View"](#).
- NO >> Repair or replace harness.

A
B
C
D
E
F
G
H
I
K
L
M
N
O
P

ADP

MIRROR SENSOR

< DTC/CIRCUIT DIAGNOSIS >

MIRROR SENSOR DRIVER SIDE

DRIVER SIDE : Description

INFOID:000000008901585

- The mirror sensor LH is installed to the door mirror LH.
- The resistance of 2 sensors (horizontal and vertical) is changed when the door mirror LH is operated.
- Automatic drive positioner control unit calculates the door mirror position according to the change of the voltage of 2 sensor input terminals.

DRIVER SIDE : Component Function Check

INFOID:000000008901586

1. CHECK FUNCTION

1. Select "MIR/SEN LH U-D", "MIR/SEN LH R-L" in "DATA MONITOR" mode with CONSULT.
2. Check mirror sensor (driver side) signal under the following condition.

Monitor item	Condition	Value
MIR/SEN LH U-D	Close to peak	3.4V
	Close to valley	0.6V
MIR/SEN LH R-L	Close to right edge	3.4V
	Close to left edge	0.6V

Is the inspection result normal?

YES >> Inspection End.

NO >> Perform diagnosis procedure. Refer to [ADP-130, "DRIVER SIDE : Diagnosis Procedure"](#).

DRIVER SIDE : Diagnosis Procedure

INFOID:000000008901587

Regarding Wiring Diagram information, refer to [ADP-50, "WITH AROUND VIEW MONITOR : Wiring Diagram"](#) or [ADP-36, "WITHOUT AROUND VIEW MONITOR : Wiring Diagram"](#).

1. CHECK DOOR MIRROR LH SENSOR SIGNAL

1. Turn ignition switch to ACC.
2. Check voltage between door mirror LH harness connector and ground.

(+) Door mirror LH		(-)	Condition	Voltage (V) (Approx.)	
Connector	Terminal				
D28 (with around view monitor system)	21	Ground	Door mirror LH	Close to peak	3.4
				Close to valley	0.6
	22		Door mirror LH	Close to right edge	3.4
				Close to left edge	0.6
D4 (without around view monitor system)	4	Ground	Door mirror LH	Close to peak	3.4
				Close to valley	0.6
	6		Door mirror LH	Close to right edge	3.4
				Close to left edge	0.6

Is the inspection result normal?

YES >> GO TO 5.

NO >> GO TO 2.

2. CHECK DOOR MIRROR LH SENSOR CIRCUIT 1

1. Turn ignition switch OFF.

MIRROR SENSOR

< DTC/CIRCUIT DIAGNOSIS >

2. Disconnect automatic drive positioner control unit and door mirror LH connector.
3. Check continuity between automatic drive positioner control unit harness connector and door mirror LH harness connector.

Automatic drive positioner control unit		Door mirror LH		Continuity
Connector	Terminal	Connector	Terminal	
M33	6	D28 (with around view monitor system)	21	Yes
		D4 (without around view monitor system)	4	
	18	D28 (with around view monitor system)	22	
		D4 (without around view monitor system)	6	

4. Check continuity between automatic drive positioner control unit harness connector and ground.

Automatic drive positioner control unit		Ground	Continuity
Connector	Terminal		
M33	6		No
	18		

Is the inspection result normal?

- YES >> GO TO 3.
 NO >> Repair or replace harness.

3. CHECK DOOR MIRROR LH SENSOR CIRCUIT 2

1. Check continuity between automatic drive positioner control unit harness connector and door mirror LH harness connector.

Automatic drive positioner control unit		Door mirror LH		Continuity
Connector	Terminal	Connector	Terminal	
M33	20	D28 (with around view monitor system)	24	Yes
		D4 (without around view monitor system)	5	
	21	D28 (with around view monitor system)	23	
		D4 (without around view monitor system)	3	

2. Check continuity between automatic drive positioner control unit harness connector and ground.

Automatic drive positioner control unit		Ground	Continuity
Connector	Terminal		
M33	20		No
	21		

Is the inspection result normal?

- YES >> GO TO 4.
 NO >> Repair or replace harness.

4. CHECK TILT MOTOR ADJUSTING OPERATION

1. Connect automatic drive positioner control unit and door mirror LH.
2. Turn ignition switch ON.
3. Check tilt motor adjusting operation with memory function.

MIRROR SENSOR

< DTC/CIRCUIT DIAGNOSIS >

Is the operation normal?

- YES >> Replace door mirror actuator. (Built in door mirror LH). Refer to [MIR-20, "Removal and Installation"](#).
- NO >> Replace automatic drive positioner control unit. Refer to [ADP-157, "Removal and Installation"](#).

5. CHECK INTERMITTENT INCIDENT

Refer to [GI-49, "Intermittent Incident"](#).

Is the inspection result normal?

- YES >> Replace automatic drive positioner control unit. Refer to [ADP-157, "Removal and Installation"](#).
- NO >> Repair or replace the malfunctioning part.

PASSENGER SIDE

PASSENGER SIDE : Description

INFOID:000000008901588

- The mirror sensor RH is installed to the door mirror RH.
- The resistance of 2 sensors (horizontal and vertical) is changed when the door mirror RH is operated.
- Automatic drive positioner control unit calculates the door mirror position according to the change of the voltage of 2 sensor input terminals.

PASSENGER SIDE : Component Function Check

INFOID:000000008901589

1. CHECK FUNCTION

1. Select "MIR/SEN RH U-D", "MIR/SEN RH R-L" in "DATA MONITOR" mode with CONSULT.
2. Check the mirror sensor RH signal under the following conditions.

Monitor item	Condition		Value
MIR/SEN RH U-D	Door mirror RH	Close to peak	3.4V
		Close to valley	0.6V
MIR/SEN RH R-L		Close to right edge	3.4V
		Close to left edge	0.6V

Is the inspection result normal?

- YES >> Inspection End.
- NO >> Perform diagnosis procedure. Refer to [ADP-132, "PASSENGER SIDE : Diagnosis Procedure"](#).

PASSENGER SIDE : Diagnosis Procedure

INFOID:000000008901590

Regarding Wiring Diagram information, refer to [ADP-50, "WITH AROUND VIEW MONITOR : Wiring Diagram"](#) or [ADP-36, "WITHOUT AROUND VIEW MONITOR : Wiring Diagram"](#).

1. CHECK DOOR MIRROR RH SENSOR SIGNAL

1. Turn ignition switch to ACC.
2. Check voltage between door mirror RH harness connector and ground.

(+) Door mirror LH		(-)	Condition	Voltage (V) (Approx.)	
Connector	Terminal				
D128 (with around view monitor system)	21	Ground	Door mirror RH	Close to peak	3.4
			Close to valley	0.6	
	22		Close to right edge	3.4	
			Close to left edge	0.6	

MIRROR SENSOR

< DTC/CIRCUIT DIAGNOSIS >

(+)		(-)	Condition	Voltage (V) (Approx.)	
Door mirror LH					
Connector	Terminal				
D107 (without around view monitor system)	4	Ground	Door mirror RH	Close to peak	3.4
				Close to valley	0.6
	6			Close to right edge	3.4
				Close to left edge	0.6

Is the inspection result normal?

YES >> GO TO 5.

NO >> GO TO 2.

2. CHECK DOOR MIRROR RH SENSOR CIRCUIT 1

1. Turn ignition switch OFF.
2. Disconnect automatic drive positioner control unit and door mirror RH.
3. Check continuity between automatic drive positioner control unit harness connector and door mirror RH harness connector.

Automatic drive positioner control unit		Door mirror RH		Continuity
Connector	Terminal	Connector	Terminal	
M33	5	D128 (with around view monitor system)	21	Yes
		D107 (without around view monitor system)	4	
	17	D128 (with around view monitor system)	22	
		D107 (without around view monitor system)	6	

4. Check continuity between automatic drive positioner control unit harness connector and ground.

Automatic drive positioner control unit		Ground	Continuity
Connector	Terminal		
M33	5		No
	17		

Is the inspection result normal?

YES >> GO TO 3.

NO >> Repair or replace harness.

3. CHECK DOOR MIRROR RH SENSOR CIRCUIT 2

1. Check continuity between automatic drive positioner control unit harness connector and door mirror RH harness connector.

Automatic drive positioner control unit		Door mirror RH		Continuity
Connector	Terminal	Connector	Terminal	
M33	20	D128 (with around view monitor system)	24	Yes
		D107 (without around view monitor system)	5	
	21	D128 (with around view monitor system)	23	
		D107 (without around view monitor system)	3	

MIRROR SENSOR

< DTC/CIRCUIT DIAGNOSIS >

2. Check continuity between automatic drive positioner control unit harness connector and ground.

Automatic drive positioner control unit		Ground	Continuity
Connector	Terminal		
M33	20		No
	21		

Is the inspection result normal?

YES >> GO TO 4.

NO >> Repair or replace harness.

4. CHECK TILT MOTOR ADJUSTING OPERATION

1. Connect automatic drive positioner control unit and door mirror RH.
2. Turn ignition switch ON.
3. Check tilt motor adjusting operation with memory function.

Is the operation normal?

YES >> Replace door mirror actuator. (Built in door mirror RH). Refer to [MIR-20, "Removal and Installation"](#).

NO >> Replace automatic drive positioner control unit. Refer to [ADP-157, "Removal and Installation"](#).

5. CHECK INTERMITTENT INCIDENT

Refer to [GI-49, "Intermittent Incident"](#).

Is the inspection result normal?

YES >> Replace automatic drive positioner control unit. Refer to [ADP-157, "Removal and Installation"](#).

NO >> Repair or replace the malfunctioning part.

SLIDING MOTOR

< DTC/CIRCUIT DIAGNOSIS >

SLIDING MOTOR

Description

INFOID:000000008901591

- The sliding motor LH is installed to the seat frame.
- The sliding motor LH is activated with the driver seat control unit.
- The seat is slid forward/backward by changing the rotation direction of sliding motor LH.

Component Function Check

INFOID:000000008901592

1. CHECK FUNCTION

1. Select "SEAT SLIDE" in "ACTIVE TEST" mode with CONSULT.
2. Check the sliding motor LH operation.

Test Item		Description	
SEAT SLIDE	OFF	Seat sliding	Stop
	FR		Forward
	RR		Backward

Is the operation of relevant parts normal?

- YES >> Inspection End.
NO >> Perform diagnosis procedure. Refer to [ADP-135, "Diagnosis Procedure"](#).

Diagnosis Procedure

INFOID:000000008901593

Regarding Wiring Diagram information, refer to [ADP-50, "WITH AROUND VIEW MONITOR : Wiring Diagram"](#) or [ADP-36, "WITHOUT AROUND VIEW MONITOR : Wiring Diagram"](#).

1. CHECK SLIDING MOTOR LH POWER SUPPLY

ADP

1. Turn the ignition switch to ACC.
2. Perform "ACTIVE TEST" ("SEAT SLIDE") with CONSULT.
3. Check voltage between driver seat control unit harness connector and ground.

(+) Driver seat control unit		(-)	Condition	Voltage (V) (Approx.)	
Connector	Terminal				
B210	36	Ground	SEAT SLIDE	OFF	0
				FR (forward)	0
				RR (backward)	Battery voltage
	44			OFF	0
				FR (forward)	Battery voltage
				RR (backward)	0

Is the inspection result normal?

- YES >> Replace sliding motor LH. Refer to [SE-85, "Removal and Installation"](#).
NO >> GO TO 2.

2. CHECK SLIDING MOTOR LH CIRCUIT

1. Turn ignition switch OFF.
2. Disconnect driver seat control unit and sliding motor LH.
3. Check continuity between driver seat control unit harness connector and sliding motor LH harness connector.

SLIDING MOTOR

< DTC/CIRCUIT DIAGNOSIS >

Driver seat control unit		Sliding motor LH		Continuity
Connector	Terminal	Connector	Terminal	
B210	36	B211	4	Yes
	44		5	

4. Check continuity between driver seat control unit harness connector and ground.

Driver seat control unit connector		Ground	Continuity
Connector	Terminal		
B210	36		No
	44		

Is the inspection result normal?

YES >> GO TO 3.

NO >> Repair or replace harness.

3. CHECK INTERMITTENT INCIDENT

Refer to [GI-49. "Intermittent Incident"](#).

Is the inspection result normal?

YES >> Replace driver seat control unit. Refer to [ADP-156. "Removal and Installation"](#).

NO >> Repair or replace the malfunctioning part.

RECLINING MOTOR

< DTC/CIRCUIT DIAGNOSIS >

RECLINING MOTOR

Description

INFOID:000000008901594

- The reclining motor LH is installed to the seatback assembly.
- The reclining motor LH is activated with the driver seat control unit.
- The seatback is reclined forward/backward by changing the rotation direction of reclining motor LH.

Component Function Check

INFOID:000000008901595

1. CHECK FUNCTION

1. Select "SEAT RECLINING" in "ACTIVE TEST" mode with CONSULT.
2. Check the reclining motor LH operation.

Test Item		Description	
SEAT RECLINING	OFF	Seat reclining	Stop
	FR		Forward
	RR		Backward

Is the operation of relevant parts normal?

YES >> Inspection End.

NO >> Perform diagnosis procedure. Refer to [ADP-137, "Diagnosis Procedure"](#).

Diagnosis Procedure

INFOID:000000008901596

Regarding Wiring Diagram information, refer to [ADP-50, "WITH AROUND VIEW MONITOR : Wiring Diagram"](#) or [ADP-36, "WITHOUT AROUND VIEW MONITOR : Wiring Diagram"](#).

1. CHECK RECLINING MOTOR LH POWER SUPPLY

1. Turn the ignition switch to ACC.
2. Perform "ACTIVE TEST" ("SEAT RECLINING") with CONSULT.
3. Check voltage between driver seat control unit harness connector and ground.

(+)		(-)	Condition	Voltage (V) (Approx.)	
Driver seat control unit	Terminal				
B210	43	Ground	SEAT RE-CLINING	OFF	0
			FR (forward)	0	
			RR (backward)	Battery voltage	
	35		OFF	0	
			FR (forward)	Battery voltage	
			RR (backward)	0	

Is the inspection result normal?

YES >> Replace reclining motor LH. Refer to [SE-85, "Removal and Installation"](#).

NO >> GO TO 2.

2. CHECK RECLINING MOTOR LH CIRCUIT

1. Turn ignition switch OFF.
2. Disconnect driver seat control unit and reclining motor LH.
3. Check continuity between driver seat control unit harness connector and reclining motor LH harness connector.

RECLINING MOTOR

< DTC/CIRCUIT DIAGNOSIS >

Driver seat control unit		Reclining motor LH		Continuity
Connector	Terminal	Connector	Terminal	
B210	35	B217	6	Yes
	43		4	

4. Check continuity between driver seat control unit harness connector and ground.

Driver seat control unit		Ground	Continuity
Connector	Terminal		
B210	35		No
	43		

Is the inspection result normal?

YES >> GO TO 3.

NO >> Repair or replace harness.

3. CHECK INTERMITTENT INCIDENT

Refer to [GI-49. "Intermittent Incident"](#).

Is the inspection result normal?

YES >> Replace driver seat control unit. Refer to [ADP-156. "Removal and Installation"](#).

NO >> Repair or replace the malfunctioning part.

LIFTING MOTOR (FRONT)

< DTC/CIRCUIT DIAGNOSIS >

LIFTING MOTOR (FRONT)

Description

INFOID:000000008901597

- The lifting motor LH (front) is installed to the seat frame.
- The lifting motor LH (front) is activated with the driver seat control unit.
- The lifter (front) is moved upward/downward by changing the rotation direction of lifting motor LH (front).

Component Function Check

INFOID:000000008901598

1. CHECK FUNCTION

1. Select "SEAT LIFTER FR" in "ACTIVE TEST" mode with CONSULT.
2. Check the lifting motor LH (front) operation.

Test Item		Description	
SEAT LIFTER FR	OFF	Seat lifting (front)	Stop
	UP		Upward
	DWN		Downward

Is the operation of relevant parts normal?

- YES >> Inspection End.
 NO >> Perform diagnosis procedure. Refer to [ADP-139, "Diagnosis Procedure"](#).

Diagnosis Procedure

INFOID:000000008901599

Regarding Wiring Diagram information, refer to [ADP-50, "WITH AROUND VIEW MONITOR : Wiring Diagram"](#) or [ADP-36, "WITHOUT AROUND VIEW MONITOR : Wiring Diagram"](#).

1. CHECK LIFTING MOTOR LH (FRONT) POWER SUPPLY

ADP

1. Turn the ignition switch to ACC.
2. Perform "ACTIVE TEST" ("SEAT LIFTER FR") with CONSULT.
3. Check voltage between driver seat control unit harness connector and ground.

(+)		(-)	Condition	Voltage (V) (Approx.)
Connector	Terminal			
B210	34	Ground	SEAT LIFTER FR OFF	0
			SEAT LIFTER FR UP	0
			SEAT LIFTER FR DWN (down)	Battery voltage
	42		SEAT LIFTER FR OFF	0
			SEAT LIFTER FR UP	Battery voltage
			SEAT LIFTER FR DWN (down)	0

Is the inspection result normal?

- YES >> Replace lifting motor LH (front). Refer to [SE-85, "Removal and Installation"](#).
 NO >> GO TO 2.

2. CHECK LIFTING MOTOR LH (FRONT) CIRCUIT

1. Turn ignition switch OFF.
2. Disconnect driver seat control unit and lifting motor LH (front).
3. Check continuity between driver seat control unit harness connector and lifting motor LH (front) harness connector.

LIFTING MOTOR (FRONT)

< DTC/CIRCUIT DIAGNOSIS >

Driver seat control unit		Lifting motor LH (front)		Continuity
Connector	Terminal	Connector	Terminal	
B210	34	B218	6	Yes
	42		4	

4. Check continuity between driver seat control unit harness connector and ground.

Driver seat control unit		Ground	Continuity
Connector	Terminal		
B210	34		No
	42		

Is the inspection result normal?

YES >> GO TO 3.

NO >> Repair or replace harness.

3. CHECK INTERMITTENT INCIDENT

Refer to [GI-49. "Intermittent Incident"](#).

Is the inspection result normal?

YES >> Replace driver seat control unit. Refer to [ADP-156. "Removal and Installation"](#).

NO >> Repair or replace the malfunctioning part.

LIFTING MOTOR (REAR)

< DTC/CIRCUIT DIAGNOSIS >

LIFTING MOTOR (REAR)

Description

INFOID:000000008901600

- The lifting motor LH (rear) is installed to the seat frame.
- The lifting motor LH (rear) is activated with the driver seat control unit.
- The seat lifter (rear) is moved upward/downward by changing the rotation direction of lifting motor LH (rear).

Component Function Check

INFOID:000000008901601

1. CHECK FUNCTION

1. Select "SEAT LIFTER RR" in "ACTIVE TEST" mode with CONSULT.
2. Check the lifting motor LH (rear) operation.

Test Item		Description	
SEAT LIFTER RR	OFF	Seat lifting (rear)	Stop
	UP		Upward
	DWN		Downward

Is the operation of relevant parts normal?

- YES >> Inspection End.
 NO >> Perform diagnosis procedure. Refer to [ADP-141, "Diagnosis Procedure"](#).

Diagnosis Procedure

INFOID:000000008901602

Regarding Wiring Diagram information, refer to [ADP-50, "WITH AROUND VIEW MONITOR : Wiring Diagram"](#) or [ADP-36, "WITHOUT AROUND VIEW MONITOR : Wiring Diagram"](#).

1. CHECK LIFTING MOTOR LH (REAR) POWER SUPPLY

ADP

1. Turn the ignition switch to ACC.
2. Perform "ACTIVE TEST" ("SEAT LIFTER RR") with CONSULT.
3. Check voltage between driver seat control unit harness connector and ground.

(+)		(-)	Condition	Voltage (V) (Approx.)
Connector	Terminal			
B210	40	Ground	SEAT LIFTER RR OFF	0
			SEAT LIFTER RR UP	0
			SEAT LIFTER RR DWN (down)	Battery voltage
	41		SEAT LIFTER RR OFF	0
			SEAT LIFTER RR UP	Battery voltage
			SEAT LIFTER RR DWN (down)	0

Is the inspection result normal?

- YES >> Replace lifting motor LH (rear). Refer to [SE-85, "Removal and Installation"](#).
 NO >> GO TO 2.

2. CHECK LIFTING MOTOR (REAR) CIRCUIT

1. Turn ignition switch OFF.
2. Disconnect driver seat control unit and lifting motor LH (rear).
3. Check continuity between driver seat control unit harness connector and lifting motor LH (rear) harness connector.

LIFTING MOTOR (REAR)

< DTC/CIRCUIT DIAGNOSIS >

Driver seat control unit		Lifting motor LH (rear)		Continuity
Connector	Terminal	Connector	Terminal	
B210	41	B207	6	Yes
	40		4	

4. Check continuity between driver seat control unit harness connector and ground.

Driver seat control unit		Ground	Continuity
Connector	Terminal		
B210	41		No
	40		

Is the inspection result normal?

YES >> GO TO 3.

NO >> Repair or replace harness.

3. CHECK INTERMITTENT INCIDENT

Refer to [GI-49. "Intermittent Incident"](#).

Is the inspection result normal?

YES >> Replace driver seat control unit. Refer to [ADP-156. "Removal and Installation"](#).

NO >> Repair or replace the malfunctioning part.

TILT MOTOR

< DTC/CIRCUIT DIAGNOSIS >

TILT MOTOR

Description

INFOID:000000008901603

- The tilt motor is installed to the steering column assembly.
- The tilt motor is activated with the automatic drive positioner control unit.
- The steering column is tilted upward/downward by changing the rotation direction of tilt motor.

Component Function Check

INFOID:000000008901604

1. CHECK FUNCTION

1. Select "TILT MOTOR" in "ACTIVE TEST" mode with CONSULT.
2. Check the tilt motor operation.

Test item		Description	
TILT MOTOR	OFF	Steering tilt	Stop
	UP		Upward
	DWN		Downward

Is the operation of relevant parts normal?

- YES >> Inspection End.
 NO >> Perform diagnosis procedure. Refer to [ADP-143, "Diagnosis Procedure"](#).

Diagnosis Procedure

INFOID:000000008901605

Regarding Wiring Diagram information, refer to [ADP-50, "WITH AROUND VIEW MONITOR : Wiring Diagram"](#) or [ADP-36, "WITHOUT AROUND VIEW MONITOR : Wiring Diagram"](#).

1. CHECK TILT MOTOR POWER SUPPLY

ADP

1. Turn ignition switch OFF.
2. Disconnect tilt motor.
3. Turn the ignition switch ON.
4. Perform "ACTIVE TEST" ("TILT MOTOR") with CONSULT.
5. Check voltage between tilt motor harness connector and ground.

(+)		(-)	Condition	Voltage (V) (Approx.)
Tilt motor				
Connector	Terminals			
M85	2	Ground	TILT MOTOR OFF	0
			TILT MOTOR UP	0
			TILT MOTOR DWN (down)	Battery voltage
	1		TILT MOTOR OFF	0
			TILT MOTOR UP	Battery voltage
			TILT MOTOR DWN (down)	0

Is the inspection result normal?

- YES >> Replace tilt motor. Refer to [ST-46, "Exploded View"](#).
 NO >> GO TO 2.

2. CHECK TILT MOTOR CIRCUIT

1. Turn ignition switch OFF.
2. Disconnect automatic drive positioner control unit.
3. Check continuity between automatic drive positioner control unit harness connector and tilt motor harness connector.

TILT MOTOR

< DTC/CIRCUIT DIAGNOSIS >

Automatic drive positioner control unit		Tilt motor		Continuity
Connector	Terminal	Connector	Terminal	
M34	28	M85	2	Yes
	29		1	

4. Check continuity between automatic drive positioner control unit harness connector and ground.

Automatic drive positioner control unit		Ground	Continuity
Connector	Terminal		
M34	28		No
	29		

Is the inspection result normal?

- YES >> Replace automatic drive positioner control unit. Refer to [ADP-157. "Removal and Installation"](#).
 NO >> Repair or replace harness.

TELESCOPIC MOTOR

< DTC/CIRCUIT DIAGNOSIS >

TELESCOPIC MOTOR

Description

INFOID:000000008901606

- The telescopic motor is installed to the steering column assembly.
- The telescopic motor is activated with the automatic drive positioner control unit.
- Compresses the steering column by changing the rotation direction of telescopic motor.

Component Function Check

INFOID:000000008901607

1. CHECK FUNCTION

1. Select "TELESCO MOTOR" in "ACTIVE TEST" mode with CONSULT.
2. Check the telescopic motor operation.

Test item		Description	
TELESCO MOTOR	OFF	Steering telescopic	Stop
	FR		Forward
	RR		Backward

Is the operation of relevant parts normal?

YES >> Inspection End.

NO >> Perform diagnosis procedure. Refer to [ADP-145, "Diagnosis Procedure"](#).

Diagnosis Procedure

INFOID:000000008901608

Regarding Wiring Diagram information, refer to [ADP-50, "WITH AROUND VIEW MONITOR : Wiring Diagram"](#) or [ADP-36, "WITHOUT AROUND VIEW MONITOR : Wiring Diagram"](#).

1. CHECK TELESCOPIC MOTOR POWER SUPPLY

ADP

1. Turn ignition switch OFF.
2. Disconnect telescopic motor.
3. Turn the ignition switch ON.
4. Perform "ACTIVE TEST" ("TELESCO MOTOR") with CONSULT.
5. Check voltage between telescopic motor harness connector and ground.

(+)		(-)	Condition	Voltage (V) (Approx.)	
Connector	Terminals				
M94	2	Ground	TELE- SCOPIC MOTOR	OFF	0
				FR (forward)	0
				RR (backward)	Battery voltage
	1			OFF	0
				FR (forward)	Battery voltage
				RR (backward)	0

Is the inspection result normal?

YES >> Replace telescopic motor. Refer to [ST-46, "Exploded View"](#).

NO >> GO TO 2.

2. CHECK TELESCOPIC MOTOR CIRCUIT

1. Turn ignition switch OFF.
2. Disconnect automatic drive positioner control unit.
3. Check continuity between automatic drive positioner control unit harness connector and telescopic motor harness connector.

TELESCOPIC MOTOR

< DTC/CIRCUIT DIAGNOSIS >

Automatic drive positioner control unit		Telescopic motor		Continuity
Connector	Terminal	Connector	Terminal	
M34	29	M94	1	Yes
	26		2	

4. Check continuity between automatic drive positioner control unit harness connector and ground.

Automatic drive positioner control unit		Ground	Continuity
Connector	Terminal		
M34	29		No
	26		

Is the inspection result normal?

- YES >> Replace automatic drive positioner control unit. Refer to [ADP-157. "Removal and Installation"](#).
 NO >> Repair or replace harness.

DOOR MIRROR MOTOR

< DTC/CIRCUIT DIAGNOSIS >

DOOR MIRROR MOTOR

Description

INFOID:000000008901609

It makes mirror face operate from side to side and up and down with the electric power that automatic drive positioner control unit supplies.

Component Function Check

INFOID:000000008901610

1. CHECK DOOR MIRROR MOTOR FUNCTION

Check the operation with "MIRROR MOTOR RH" and "MIRROR MOTOR LH" in "ACTIVE TEST" mode with CONSULT.

Refer to [ADP-22, "CONSULT Function"](#).

Is the inspection result normal?

YES >> Door mirror motor function is OK.

NO >> Refer to [ADP-147, "Diagnosis Procedure"](#).

Diagnosis Procedure

INFOID:000000008901611

Regarding Wiring Diagram information, refer to [ADP-50, "WITH AROUND VIEW MONITOR : Wiring Diagram"](#) or [ADP-36, "WITHOUT AROUND VIEW MONITOR : Wiring Diagram"](#).

WITH AROUND VIEW MONITOR SYSTEM

1. CHECK DOOR MIRROR MOTOR INPUT SIGNAL

1. Turn ignition switch ON.
2. Check voltage between door mirror connector and ground.

(+)		(-)	Door mirror remote control switch condition	Voltage (V) (Approx.)
Door mirror				
Connector	Terminal			
D28 (LH) D128 (RH)	12	Ground	UP	Battery voltage
			Other than above	0
	11		LEFT	Battery voltage
			Other than above	0
	10		DOWN / RIGHT	Battery voltage
			Other than above	0

Is the inspection result normal?

YES >> Refer to [ADP-151, "Component Inspection"](#).

NO >> GO TO 2.

2. CHECK HARNESS CONTINUITY

1. Turn ignition switch OFF.
2. Disconnect automatic drive positioner control unit and door mirror.
3. Check continuity between automatic drive positioner control unit connector and door mirror connector.
Door mirror LH

Automatic drive positioner control unit		Door mirror LH connector		Continuity
Connector	Terminal	Connector	Terminal	
M33	12	D28	10	Yes
	23		12	
	24		11	

DOOR MIRROR MOTOR

< DTC/CIRCUIT DIAGNOSIS >

Door mirror RH

Automatic drive positioner control unit		Door mirror RH		Continuity
Connector	Terminal	Connector	Terminal	
M33	10	D128	12	Yes
	11		11	
	22		10	

4. Check continuity between automatic drive positioner control unit connector and ground.

Door mirror LH

Automatic drive positioner control unit		Ground	Continuity
Connector	Terminal		
M33	12	Ground	No
	23		
	24		

Door mirror RH

Automatic drive positioner control unit		Ground	Continuity
Connector	Terminal		
M33	10	Ground	No
	11		
	22		

Is the inspection result normal?

YES >> GO TO 3.

NO >> Repair or replace harness.

3. CHECK AUTOMATIC DRIVE POSITIONER CONTROL UNIT OUTPUT SIGNAL

1. Connect automatic drive positioner control unit.
2. Turn ignition switch ON.
3. Check voltage between automatic drive positioner control unit connector and ground.

Door mirror LH

(+)		(-)	Mirror switch condition	Voltage (V) (Approx.)
Automatic drive positioner control unit				
Connector	Terminal			
M33	12	Ground	DOWN / RIGHT	Battery voltage
			Other than above	0
	23		UP	Battery voltage
			Other than above	0
	24		LEFT	Battery voltage
			Other than above	0

Door mirror RH

(+)		(-)	Mirror switch condition	Voltage (V) (Approx.)
Automatic drive positioner control unit				
Connector	Terminal			

DOOR MIRROR MOTOR

< DTC/CIRCUIT DIAGNOSIS >

M33	10	Ground	UP	Battery voltage
			Other than above	0
	11		LEFT	Battery voltage
			Other than above	0
	22		DOWN / RIGHT	Battery voltage
			Other than above	0

Is the inspection result normal?

YES >> GO TO 4.

NO >> Replace automatic drive positioner control unit. Refer to [ADP-157, "Removal and Installation"](#).

4. CHECK DOOR MIRROR MOTOR

Check door mirror motor.

Refer to [ADP-151, "Component Inspection"](#).

Is the inspection result normal?

YES >> Refer to [GI-49, "Intermittent Incident"](#).

NO >> Replace door mirror actuator. Refer to [MIR-20, "Removal and Installation"](#).

WITHOUT AROUND VIEW MONITOR SYSTEM

1. CHECK DOOR MIRROR MOTOR INPUT SIGNAL

1. Turn ignition switch ON.
2. Check voltage between door mirror connector and ground.

(+)		(-)	Door mirror remote control switch condition	Voltage (V) (Approx.)
Door mirror				
Connector	Terminal			
D4 (LH) D107 (RH)	8	Ground	UP	Battery voltage
			Other than above	0
	9		LEFT	Battery voltage
			Other than above	0
	10		DOWN / RIGHT	Battery voltage
			Other than above	0

Is the inspection result normal?

YES >> Refer to [ADP-151, "Component Inspection"](#).

NO >> GO TO 2.

2. CHECK HARNESS CONTINUITY

1. Turn ignition switch OFF.
2. Disconnect automatic drive positioner control unit and door mirror.
3. Check continuity between automatic drive positioner control unit connector and door mirror connector.
Door mirror LH

Automatic drive positioner control unit		Door mirror LH connector		Continuity
Connector	Terminal	Connector	Terminal	
M33	12	D4	10	Yes
	23		8	
	24		9	

DOOR MIRROR MOTOR

< DTC/CIRCUIT DIAGNOSIS >

Door mirror RH

Automatic drive positioner control unit		Door mirror RH		Continuity
Connector	Terminal	Connector	Terminal	
M33	10	D107	8	Yes
	11		9	
	22		10	

4. Check continuity between automatic drive positioner control unit connector and ground.

Door mirror LH

Automatic drive positioner control unit		Ground	Continuity
Connector	Terminal		
M33	12		No
	23		
	24		

Door mirror RH

Automatic drive positioner control unit		Ground	Continuity
Connector	Terminal		
M33	10		No
	11		
	22		

Is the inspection result normal?

YES >> GO TO 3.

NO >> Repair or replace harness.

3. CHECK AUTOMATIC DRIVE POSITIONER CONTROL UNIT OUTPUT SIGNAL

1. Connect automatic drive positioner control unit.
2. Turn ignition switch ON.
3. Check voltage between automatic drive positioner control unit connector and ground.

Door mirror LH

(+)		(-)	Mirror switch condition	Voltage (V) (Approx.)
Automatic drive positioner control unit				
Connector	Terminal			
M33	12	Ground	DOWN / RIGHT	Battery voltage
			Other than above	0
	23		UP	Battery voltage
			Other than above	0
	24		LEFT	Battery voltage
			Other than above	0

Door mirror RH

(+)		(-)	Mirror switch condition	Voltage (V) (Approx.)
Automatic drive positioner control unit				
Connector	Terminal			

DOOR MIRROR MOTOR

< DTC/CIRCUIT DIAGNOSIS >

M33	10	Ground	UP	Battery voltage
			Other than above	0
	11		LEFT	Battery voltage
			Other than above	0
	22		DOWN / RIGHT	Battery voltage
			Other than above	0

Is the inspection result normal?

YES >> GO TO 4.

NO >> Replace automatic drive positioner control unit. Refer to [ADP-157, "Removal and Installation"](#).

4. CHECK DOOR MIRROR MOTOR

Check door mirror motor.

Refer to [ADP-151, "Component Inspection"](#).

Is the inspection result normal?

YES >> Refer to [GI-49, "Intermittent Incident"](#).

NO >> Replace door mirror actuator. Refer to [MIR-20, "Removal and Installation"](#).

Component Inspection

INFOID:000000008901612

1. CHECK DOOR MIRROR MOTOR-I

Check that door mirror motor does not trap foreign objects and does not have any damage.

Refer to [MIR-17, "Exploded View"](#).

Is the inspection result normal?

YES >> GO TO 2.

NO >> Replace door mirror actuator. Refer to [MIR-20, "Removal and Installation"](#).

2. CHECK DOOR MIRROR MOTOR-II

1. Turn ignition switch OFF.
2. Disconnect door mirror.
3. Apply 12V to each power supply terminal of door mirror motor.

With around view monitor system

Door mirror connector	Terminal		Operational direction
	(+)	(-)	
D28 (LH) D128 (RH)	10	11	RIGHT
	11	10	LEFT
	12	10	UP
	10	12	DOWN

Without around view monitor system

Door mirror connector	Terminal		Operational direction
	(+)	(-)	
D4 (LH) D107 (RH)	10	9	RIGHT
	9	10	LEFT
	8	10	UP
	10	8	DOWN

Is the inspection result normal?

YES >> Inspection End.

NO >> Replace door mirror actuator. Refer to [MIR-20, "Removal and Installation"](#).

A
B
C
D
E
F
G
H
I
K
L
M
N
O
P

ADP

SEAT MEMORY INDICATOR

< DTC/CIRCUIT DIAGNOSIS >

SEAT MEMORY INDICATOR

Description

INFOID:000000008901613

- Memory switch is equipped on the seat memory switch installed to the driver side door trim. The operation signal is input to the driver seat control unit when the memory switch is operated.
- The status of automatic drive positioner system can be checked according to the illuminating/flashing status.

Component Function Check

INFOID:000000008901614

1. CHECK FUNCTION

1. Select "MEMORY SW INDCTR" in "ACTIVE TEST" mode with CONSULT.
2. Check the memory indicator operation.

Test item		Description	
MEMORY SW INDCTR	OFF	Memory switch indicator	OFF
	ON-1		Indicator 1: ON
	ON-2		Indicator 2: ON

Is the operation of relevant parts normal?

YES >> Inspection End.

NO >> Perform diagnosis procedure. Refer to [ADP-152. "Diagnosis Procedure"](#).

Diagnosis Procedure

INFOID:000000008901615

Regarding Wiring Diagram information, refer to [ADP-50. "WITH AROUND VIEW MONITOR : Wiring Diagram"](#) or [ADP-36. "WITHOUT AROUND VIEW MONITOR : Wiring Diagram"](#).

1. CHECK SEAT MEMORY INDICATOR CIRCUIT

1. Turn ignition switch OFF.
2. Disconnect driver seat control unit and seat memory switch.
3. Check continuity between driver seat control unit harness connector and seat memory switch harness connector.

Driver seat control unit		Seat memory switch		Continuity
Connector	Terminal	Connector	Terminal	
B209	10	D60	13	Yes
	26		14	

4. Check continuity between driver seat control unit harness connector and ground.

Driver seat control unit		Ground	Continuity
Connector	Terminal		
B209	10		No
	26		

Is the inspection result normal?

YES >> GO TO 2.

NO >> Repair or replace harness.

2. CHECK MEMORY INDICATOR POWER SUPPLY

Check voltage between seat memory switch harness connector and ground.

SEAT MEMORY INDICATOR

< DTC/CIRCUIT DIAGNOSIS >

(+)		(-)	Voltage (V) (Approx.)
Seat memory switch			
Connector	Terminals		
D60	15	Ground	Battery voltage

Is the inspection result normal?

YES >> GO TO 3.

NO >> Check the following:

- 10A fuse no.1.
- Harness for open or short between memory indicator and fuse.

3. CHECK MEMORY INDICATOR

Refer to [ADP-153. "Component Inspection"](#).

Is the inspection result normal?

YES >> GO TO 4.

NO >> Replace seat memory switch. Refer to [ADP-158. "Removal and Installation"](#).

4. CHECK INTERMITTENT INCIDENT

Refer to [GI-49. "Intermittent Incident"](#).

Is the inspection result normal?

YES >> Replace driver seat control unit. Refer to [ADP-156. "Removal and Installation"](#).

NO >> Repair or replace the malfunctioning part.

Component Inspection

INFOID:000000008901616

1. CHECK SEAT MEMORY INDICATOR

1. Disconnect seat memory switch.
2. Check continuity between seat memory switch terminals.

Terminal		Continuity
Seat memory switch		
(+)	(-)	
15	13	Yes
	14	

Is the inspection result normal?

YES >> Inspection End.

NO >> Replace seat memory switch. Refer to [ADP-158. "Removal and Installation"](#).

A
B
C
D
E
F
G
H
I
K
L
M
N
O
P

ADP

ADP SYSTEM SYMPTOMS

< SYMPTOM DIAGNOSIS >

SYMPTOM DIAGNOSIS

ADP SYSTEM SYMPTOMS

Symptom Table

INFOID:000000008901617

NOTE:

Always perform the "Basic Inspection" before performing diagnosis in the following table. Refer to [ADP-64](#), "Work Flow".

Symptom	Diagnosis procedure	Reference page
Manual functions (for specific part) do not operate.	Sliding operation	Check sliding switch. ADP-86
	Reclining operation	Check reclining switch. ADP-89
	Lifting operation (front)	Check lifting switch (front). ADP-92
	Lifting operation (rear)	Check lifting switch (rear). ADP-95
	Tilt operation	Check tilt switch. ADP-98
	Telescopic sensor	Check telescopic switch. ADP-100
	Door mirror operation	1. Changeover switch. ADP-105
		2. Mirror switch ADP-107
All parts of seat	Check power seat switch ground circuit. ADP-110	
Memory functions (for specific part) do not operate.	Sliding operation	Check sliding sensor. ADP-112
	Reclining operation	Check reclining sensor. ADP-115
	Lifting operation (front)	Check lifting sensor (front). ADP-118
	Lifting operation (rear)	Check lifting sensor (rear). ADP-121
	Tilt operation	Check tilt sensor. ADP-124
	Telescopic operation	Check telescopic sensor. ADP-127
	Door mirror operation	Check door mirror sensor. Driver side: ADP-130 Passenger side: ADP-132
Memory functions and manual functions (for specific part) do not operate.	Sliding operation	Check sliding motor LH. ADP-135
	Reclining operation	Check reclining motor LH. ADP-137
	Lifting operation (front)	Check lifting motor LH (front). ADP-139
	Lifting operation (rear)	Check lifting motor LH (rear). ADP-141
	Tilt operation	Check tilt motor. ADP-143
	Telescopic operation	Check telescopic motor. ADP-145
	Door mirror operation	Check door mirror motor. ADP-147
Entry/Exit assist function does not operate.	1. Check system setting. ADP-11	
	2. Perform initialization. ADP-68	
	3. Check front door switch (driver side). DLK-168	
Intelligent Key interlock function does not operate. (Other automatic operations and Intelligent Key system are normal)	1. Check door lock function. DLK-20	
	2. Perform memory storing. ADP-69	

NORMAL OPERATING CONDITION

< SYMPTOM DIAGNOSIS >

NORMAL OPERATING CONDITION

Description

INFOID:000000008901618

The following symptoms are normal operations, and they do not indicate a malfunction.

Symptom	Cause	Action to take	Reference page
Entry/exit assist function do not operate.	No initialization has been performed.	Perform initialization.	ADP-68
	Entry/exit assist function is disabled. NOTE: Entry/exit assist function is set to ON before delivery (initial setting).	Change the settings.	ADP-70
Entry assist function does not operate.	Manual operation with power seat switch was performed after exit assist function execution.	Perform the entry assist function.	ADP-18
Memory function, entry/exit assist function, or Intelligent Key interlock function does not operate.	The operating conditions are not fulfilled.	Fulfill the operation conditions.	Memory function: ADP-15
			Entry assist function: ADP-18
			Exit assist function: ADP-17
			Intelligent Key interlock function: ADP-19

A
B
C
D
E
F
G
H
I
K
L
M
N
O
P

ADP

DRIVER SEAT CONTROL UNIT

< REMOVAL AND INSTALLATION >

REMOVAL AND INSTALLATION

DRIVER SEAT CONTROL UNIT

Removal and Installation

INFOID:000000008508820

REMOVAL

1. Remove the driver seat. Refer to [SE-85, "Removal and Installation"](#).
2. Remove the two driver seat control unit screws (A).
⇐: Front
3. Disconnect the two harness connectors from driver seat control unit (1).
4. Remove the driver seat control unit (1).

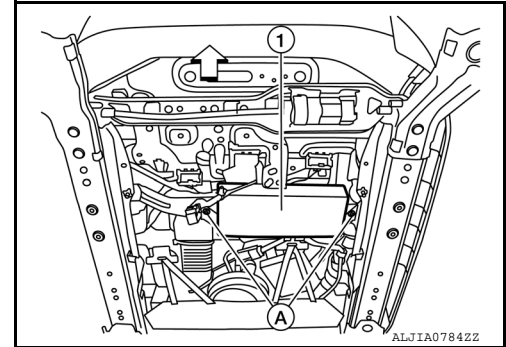

INSTALLATION

Installation is in the reverse order of removal.

NOTE:

After installing the driver seat, perform additional service when replacing control unit. Refer to [ADP-68, "ADDITIONAL SERVICE WHEN REPLACING CONTROL UNIT : Work Procedure"](#).

AUTOMATIC DRIVE POSITIONER CONTROL UNIT

< REMOVAL AND INSTALLATION >

AUTOMATIC DRIVE POSITIONER CONTROL UNIT

Removal and Installation

INFOID:000000008508821

REMOVAL

1. Disconnect the negative battery terminal. Refer to [PG-89. "Removal and Installation"](#).
2. Remove cluster lid C upper (AC and AV switch assembly). Refer to [HAC-155. "Removal and Installation"](#).
3. Remove the automatic drive positioner control unit screw (A).
4. Disconnect the two harness connectors from the automatic drive positioner control unit (1).
5. Remove automatic drive positioner control unit (1).

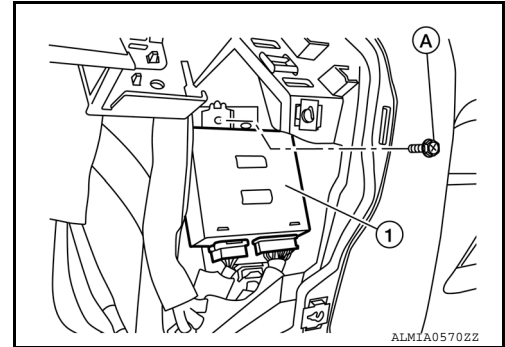

INSTALLATION

Installation is in the reverse order of removal.

NOTE:

After installing the automatic drive positioner control unit, perform additional service. Refer to [ADP-68. "ADDITIONAL SERVICE WHEN REPLACING CONTROL UNIT : Work Procedure"](#).

A
B
C
D
E
F
G
H
I
K
L
M
N
O
P

ADP

SEAT MEMORY SWITCH

< REMOVAL AND INSTALLATION >

SEAT MEMORY SWITCH

Removal and Installation

INFOID:000000008508822

REMOVAL

1. Remove front door finisher LH. Refer to [INT-15. "Removal and Installation"](#).
2. Release the pawls using a suitable tool (A) and remove seat memory switch (2) from switch finisher (1).

: Pawl

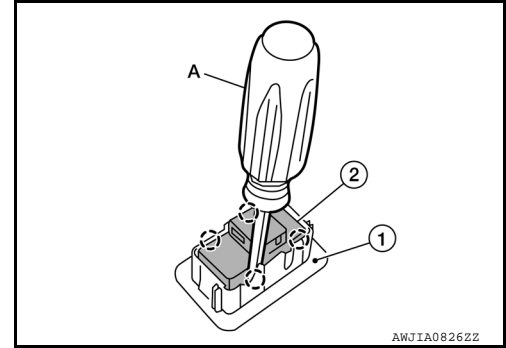

INSTALLATION

Installation is in the reverse order of removal.

POWER SEAT SWITCH

< REMOVAL AND INSTALLATION >

POWER SEAT SWITCH

Removal and Installation

INFOID:000000008508823

REMOVAL

1. Remove seat cushion outer finisher LH (2). Refer to [SE-112](#), "[Disassembly and Assembly](#)".
⇐: Front
2. Remove the power seat switch screws (A).
3. Remove power seat switch (1) from seat cushion outer finisher LH (2).

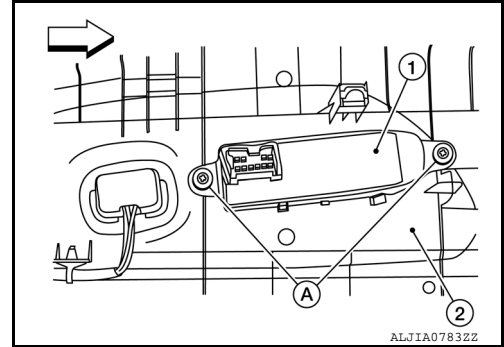

INSTALLATION

Installation is in the reverse order of removal.

A
B
C
D
E
F
G
H
I
K
L
M
N
O
P

ADP

ADP STEERING SWITCH

< REMOVAL AND INSTALLATION >

ADP STEERING SWITCH

Removal and Installation

INFOID:000000008508824

REMOVAL

1. Remove steering column lower cover (1). Refer to [IP-17. "Removal and Installation"](#).
2. Release the pawls and remove ADP steering switch (2) from the steering column lower cover (1).

: Pawl

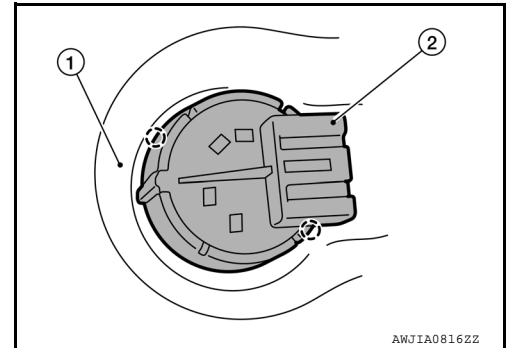

INSTALLATION

Installation is in the reverse order of removal.