

SECTION HAC

HEATER & AIR CONDITIONING CONTROL SYSTEM

CONTENTS

AUTOMATIC AIR CONDITIONING		
PRECAUTION	5	
PRECAUTIONS	5	
Precaution for Supplemental Restraint System (SRS) "AIR BAG" and "SEAT BELT PRE-TENSIONER"	5	
Working with HFC-134a (R-134a)	5	
Precautions For Refrigerant System Service	6	
Precaution for Service Equipment	9	
PREPARATION	11	
PREPARATION	11	
Special Service Tool	11	
Commercial Service Tool	11	
SYSTEM DESCRIPTION	12	
COMPONENT PARTS	12	
FRONT AUTOMATIC AIR CONDITIONING SYSTEM	12	
FRONT AUTOMATIC AIR CONDITIONING SYSTEM : Component Parts Location	12	
FRONT AUTOMATIC AIR CONDITIONING SYSTEM : Component Description	13	
REAR AUTOMATIC AIR CONDITIONING SYSTEM	15	
REAR AUTOMATIC AIR CONDITIONING SYSTEM : Component Parts Location	16	
REAR AUTOMATIC AIR CONDITIONING SYSTEM : Component Description	17	
SYSTEM	19	
FRONT AUTOMATIC AIR CONDITIONING SYSTEM	19	
FRONT AUTOMATIC AIR CONDITIONING SYSTEM : System Diagram	19	
FRONT AUTOMATIC AIR CONDITIONING SYSTEM : System Description	19	
FRONT AUTOMATIC AIR CONDITIONING SYSTEM : Intelligent Key Interlock Function	20	
FRONT AUTOMATIC AIR CONDITIONING SYSTEM : Air Flow Control	21	
FRONT AUTOMATIC AIR CONDITIONING SYSTEM : Air Inlet Control	22	
FRONT AUTOMATIC AIR CONDITIONING SYSTEM : Air Outlet Control	22	
FRONT AUTOMATIC AIR CONDITIONING SYSTEM : Compressor Control	23	
FRONT AUTOMATIC AIR CONDITIONING SYSTEM : Door Control	24	
FRONT AUTOMATIC AIR CONDITIONING SYSTEM : Temperature Control	26	
FRONT AUTOMATIC AIR CONDITIONING SYSTEM : Fail-safe	26	
REAR AUTOMATIC AIR CONDITIONING SYSTEM	26	
REAR AUTOMATIC AIR CONDITIONING SYSTEM : System Diagram	27	
REAR AUTOMATIC AIR CONDITIONING SYSTEM : System Description	27	
REAR AUTOMATIC AIR CONDITIONING SYSTEM : Intelligent Key Interlock Function	28	
REAR AUTOMATIC AIR CONDITIONING SYSTEM : Air Flow Control	29	
REAR AUTOMATIC AIR CONDITIONING SYSTEM : Air Outlet Control	30	
REAR AUTOMATIC AIR CONDITIONING SYSTEM : Door Control	30	
REAR AUTOMATIC AIR CONDITIONING SYSTEM : Temperature Control	31	
OPERATION	32	
FRONT AUTOMATIC AIR CONDITIONING SYSTEM	32	

A
B
C
D
E
F
G
H
HAC
J
K
L
M
N
O
P

FRONT AUTOMATIC AIR CONDITIONING SYSTEM : Switch Name and Function	32	DTC/CIRCUIT DIAGNOSIS	82
REAR AUTOMATIC AIR CONDITIONING SYSTEM	36	U1000 CAN COMM CIRCUIT	82
REAR AUTOMATIC AIR CONDITIONING SYSTEM : Switch Name and Function	36	Description	82
DIAGNOSIS SYSTEM (HVAC)	40	DTC Logic	82
Description	40	Diagnosis Procedure	82
CONSULT Function	40	U1010 CONTROL UNIT (CAN)	83
ECU DIAGNOSIS INFORMATION	43	Description	83
A/C AUTO AMP.	43	DTC Logic	83
Reference Value	43	Diagnosis Procedure	83
Fail-safe	46	B2578, B2579 IN-VEHICLE SENSOR	84
DTC Index	47	DTC Logic	84
ECM, IPDM E/R, BCM	49	Diagnosis Procedure	84
List of ECU Reference	49	Component Inspection	85
WIRING DIAGRAM	50	B257B, B257C AMBIENT SENSOR	87
AUTOMATIC AIR CONDITIONING SYSTEM ...	50	DTC Logic	87
Wiring Diagram	50	Diagnosis Procedure	87
BASIC INSPECTION	71	Component Inspection	88
DIAGNOSIS AND REPAIR WORK FLOW	71	B2581, B2582 INTAKE SENSOR	90
Work Flow	71	DTC Logic	90
OPERATION INSPECTION	74	Diagnosis Procedure	90
FRONT AUTOMATIC AIR CONDITIONING SYSTEM	74	Component Inspection	91
FRONT AUTOMATIC AIR CONDITIONING SYSTEM : Work Procedure	74	B2630, B2631 SUNLOAD SENSOR	93
REAR AUTOMATIC AIR CONDITIONING SYSTEM	75	DTC Logic	93
REAR AUTOMATIC AIR CONDITIONING SYSTEM : Work Procedure	76	Diagnosis Procedure	93
SYSTEM SETTING	79	Component Inspection	94
FRONT AUTOMATIC AIR CONDITIONING SYSTEM	79	B2632, B2633 AIR MIX DOOR MOTOR (DRIVER SIDE)	96
FRONT AUTOMATIC AIR CONDITIONING SYSTEM : Temperature Setting Trimmer (Front)	79	DTC Logic	96
FRONT AUTOMATIC AIR CONDITIONING SYSTEM : Foot Position Setting Trimmer	79	Diagnosis Procedure	96
FRONT AUTOMATIC AIR CONDITIONING SYSTEM : Inlet Port Memory Function (FRE)	80	B2634, B2635 AIR MIX DOOR MOTOR (PASSENGER SIDE)	98
FRONT AUTOMATIC AIR CONDITIONING SYSTEM : Inlet Port Memory Function (REC)	80	DTC Logic	98
REAR AUTOMATIC AIR CONDITIONING SYSTEM	80	Diagnosis Procedure	98
REAR AUTOMATIC AIR CONDITIONING SYSTEM : Temperature Setting Trimmer (Rear)	80	B2636, B2637, B2638, B2639, B2654 MODE DOOR MOTOR (FRONT)	100
		DTC Logic	100
		Diagnosis Procedure	100
		B263D, B263E, B263F INTAKE DOOR MOTOR	102
		DTC Logic	102
		Diagnosis Procedure	102
		B2799, B279A AIR MIX DOOR MOTOR (REAR)	104
		DTC Logic	104
		Diagnosis Procedure	104
		B279B, B279C MODE DOOR MOTOR (REAR)	106
		DTC Logic	106
		Diagnosis Procedure	106

B279D, B279E REAR SHUT-OFF DOOR MOTOR	108	Diagnosis Procedure	127	
DTC Logic	108	DOOR MOTOR COMMUNICATION CIRCUIT	129	A
Diagnosis Procedure	108	Diagnosis Procedure	129	
B2796, B2797, B2798 COMMUNICATION ERROR	110	FRONT BLOWER MOTOR	131	B
DTC Logic	110	Diagnosis Procedure	131	
Diagnosis Procedure	110	Component Inspection (Front Blower Motor)	132	C
B27B0 A/C AUTO AMP.	112	Component Inspection (Front Blower Motor Relay)	132	
DTC Logic	112	MAGNET CLUTCH	134	D
Diagnosis Procedure	112	Component Function Check	134	
POWER SUPPLY AND GROUND CIRCUIT ...	113	Diagnosis Procedure	134	
A/C AUTO AMP.	113	PTC HEATER RELAY	135	E
A/C AUTO AMP. : Diagnosis Procedure	113	Description	135	
AIR MIX DOOR MOTOR (DRIVER SIDE)	113	Component Function Check	135	
AIR MIX DOOR MOTOR (DRIVER SIDE) : Diagnosis Procedure	113	Diagnosis Procedure	135	F
AIR MIX DOOR MOTOR (PASSENGER SIDE)	114	Component Inspection	136	
AIR MIX DOOR MOTOR (PASSENGER SIDE) : Diagnosis Procedure	114	PTC HEATER	137	G
AIR MIX DOOR MOTOR (REAR)	115	Diagnosis Procedure	137	
AIR MIX DOOR MOTOR (REAR) : Diagnosis Procedure	115	REAR BLOWER MOTOR	139	H
MODE DOOR MOTOR (FRONT)	116	Diagnosis Procedure	139	
MODE DOOR MOTOR (FRONT) : Diagnosis Procedure	116	Component Inspection (Rear Blower Motor)	143	
MODE DOOR MOTOR (REAR)	117	Component Inspection (Rear Blower Motor Relay)	143	
MODE DOOR MOTOR (REAR) : Diagnosis Procedure	117	Component Inspection (Rear Blower Motor Resistor)	143	HAC
INTAKE DOOR MOTOR	118	SYMPTOM DIAGNOSIS	145	J
INTAKE DOOR MOTOR : Diagnosis Procedure ..	118	FRONT AUTOMATIC AIR CONDITIONING SYSTEM	145	
A/C SWITCH ASSEMBLY	119	Diagnosis Chart By Symptom	145	K
A/C SWITCH ASSEMBLY : Component Function Check	119	REAR AUTOMATIC AIR CONDITIONING SYSTEM	147	
A/C SWITCH ASSEMBLY : Diagnosis Procedure ..	120	Diagnosis Chart By Symptom	147	L
A/C DISPLAY UNIT	120	INSUFFICIENT COOLING	148	M
A/C DISPLAY UNIT : Diagnosis Procedure	120	FRONT AIR CONDITIONER	148	
REAR SHUT-OFF DOOR MOTOR	121	FRONT AIR CONDITIONER : Description	148	
REAR SHUT-OFF DOOR MOTOR : Diagnosis Procedure	121	FRONT AIR CONDITIONER : Diagnosis Procedure	148	N
REAR A/C CONTROL	122	REAR AIR CONDITIONER	149	
REAR A/C CONTROL : Diagnosis Procedure	122	REAR AIR CONDITIONER : Description	149	O
A/C SWITCH ASSEMBLY SIGNAL CIRCUIT ..	124	REAR AIR CONDITIONER : Diagnosis Procedure ..	149	
Diagnosis Procedure	124	INSUFFICIENT HEATING	150	P
A/C DISPLAY	126	FRONT AIR CONDITIONER	150	
Diagnosis Procedure	126	FRONT AIR CONDITIONER : Description	150	
DOOR MOTOR	127	FRONT AIR CONDITIONER : Diagnosis Procedure	150	
		REAR AIR CONDITIONER	150	
		REAR AIR CONDITIONER : Description	151	

REAR AIR CONDITIONER : Diagnosis Procedure ..151	Removal and Installation 161
INTELLIGENT KEY INTERLOCK FUNCTION DOES NOT OPERATE 152	DOOR MOTOR 162
Description152	Exploded View 162
Diagnosis Procedure152	MODE DOOR MOTOR 163
COMPRESSOR DOES NOT OPERATE 153	MODE DOOR MOTOR : Removal and Installation
Description153	- Mode Door Motor (Front) 163
Diagnosis Procedure153	MODE DOOR MOTOR : Removal and Installation
REMOVAL AND INSTALLATION 155	- Mode Door Motor (Rear) 163
A/C SWITCH 155	AIR MIX DOOR MOTOR 164
Removal and Installation 155	AIR MIX DOOR MOTOR : Removal and Installation
A/C AUTO AMP. 156	- Air Mix Door Motor (Driver Side) 164
Exploded View156	AIR MIX DOOR MOTOR : Removal and Installation
Removal and Installation156	- Air Mix Door Motor (Passenger Side) 164
AMBIENT SENSOR 157	AIR MIX DOOR MOTOR : Removal and Installation
Removal and Installation 157	- Air Mix Door Motor (Rear) 164
IN-VEHICLE SENSOR 158	INTAKE DOOR MOTOR 164
Removal and Installation158	INTAKE DOOR MOTOR : Removal and Installation
SUNLOAD SENSOR 159 164
Removal and Installation 159	REAR SHUT-OFF DOOR MOTOR 164
INTAKE SENSOR 160	REAR SHUT-OFF DOOR MOTOR : Removal and
Removal and Installation160	Installation 164
REFRIGERANT PRESSURE SENSOR 161	BLOWER MOTOR RESISTOR 166
	Removal and Installation 166
	IONIZER 167
	Exploded View 167
	Removal and Installation 167

PRECAUTION

PRECAUTIONS

Precaution for Supplemental Restraint System (SRS) "AIR BAG" and "SEAT BELT PRE-TENSIONER"

INFOID:000000008929705

The Supplemental Restraint System such as "AIR BAG" and "SEAT BELT PRE-TENSIONER", used along with a front seat belt, helps to reduce the risk or severity of injury to the driver and front passenger for certain types of collision. Information necessary to service the system safely is included in the SR and SB section of this Service Manual.

WARNING:

- To avoid rendering the SRS inoperative, which could increase the risk of personal injury or death in the event of a collision which would result in air bag inflation, all maintenance must be performed by an authorized NISSAN/INFINITI dealer.
- Improper maintenance, including incorrect removal and installation of the SRS, can lead to personal injury caused by unintentional activation of the system. For removal of Spiral Cable and Air Bag Module, see the SR section.
- Do not use electrical test equipment on any circuit related to the SRS unless instructed to in this Service Manual. SRS wiring harnesses can be identified by yellow and/or orange harnesses or harness connectors.

PRECAUTIONS WHEN USING POWER TOOLS (AIR OR ELECTRIC) AND HAMMERS

WARNING:

- When working near the Airbag Diagnosis Sensor Unit or other Airbag System sensors with the Ignition ON or engine running, DO NOT use air or electric power tools or strike near the sensor(s) with a hammer. Heavy vibration could activate the sensor(s) and deploy the air bag(s), possibly causing serious injury.
- When using air or electric power tools or hammers, always switch the Ignition OFF, disconnect the battery and wait at least 3 minutes before performing any service.

Working with HFC-134a (R-134a)

INFOID:000000008929710

WARNING:

- CFC-12 (R-12) refrigerant and HFC-134a (R-134a) refrigerant are not compatible. If the refrigerants are mixed compressor failure is likely to occur. To determine the purity of HFC-134a (R-134a) in the vehicle and recovery tank, use Refrigerant Recovery/Recycling Recharging equipment and Refrigerant Identifier.
- Use only specified oil for the HFC-134a (R-134a) A/C system and HFC-134a (R-134a) components. If oil other than that specified is used, compressor failure is likely to occur.
- The specified HFC-134a (R-134a) oil rapidly absorbs moisture from the atmosphere. The following handling precautions must be observed:
 - When removing refrigerant components from a vehicle, immediately cap (seal) the component to minimize the entry of moisture from the atmosphere.
 - When installing refrigerant components to a vehicle, do not remove the caps (unseal) until just before connecting the components. Connect all refrigerant loop components as quickly as possible to minimize the entry of moisture into system.
 - Only use the specified oil from a sealed container. Immediately reseal containers of oil. Without proper sealing, oil will become moisture saturated and should not be used.
 - Avoid breathing A/C refrigerant and oil vapor or mist. Exposure may irritate eyes, nose and throat. Remove HFC-134a (R-134a) from the A/C system using certified service equipment meeting requirements of SAE J2210 [HFC-134a (R-134a) recycling equipment] or J2209 [HFC-134a (R-134a) recycling equipment]. If accidental system discharge occurs, ventilate work area before resuming service. Additional health and safety information may be obtained from refrigerant and oil manufacturers.
 - Do not allow A/C oil to come in contact with styrofoam parts or damage may result.

CONTAMINATED REFRIGERANT

If a refrigerant other than pure HFC-134a (R-134a) is identified in a vehicle, your options are:

- Explain to the customer that environmental regulations prohibit the release of contaminated refrigerant into the atmosphere.

A
B
C
D
E
F
G
H
HAC
J
K
L
M
N
O
P

PRECAUTIONS

[AUTOMATIC AIR CONDITIONING]

< PRECAUTION >

- Explain that recovery of the contaminated refrigerant could damage your service equipment and refrigerant supply.
- Suggest the customer return the vehicle to the location of previous service where the contamination may have occurred.
- If you choose to perform the repair, recover the refrigerant using only **dedicated equipment and containers. Do not recover contaminated refrigerant into your existing service equipment.** If your facility does not have dedicated recovery equipment, you may contact a local refrigerant product retailer for available service. This refrigerant must be disposed of in accordance with all federal and local regulations. In addition, replacement of all refrigerant system components on the vehicle is recommended.
- If the vehicle is within the warranty period, the air conditioner warranty is void. Please contact NISSAN Customer Affairs for further assistance.

Precautions For Refrigerant System Service

INFOID:000000008929708

WORKING WITH HFC-134a (R-134a)

CAUTION:

- **CFC-12 (R-12) refrigerant and HFC-134a (R-134a) refrigerant are not compatible. Compressor malfunction is likely to occur if the refrigerants are mixed, refer to “CONTAMINATED REFRIGERANT” below. To determine the purity of HFC-134a (R-134a) in the vehicle and recovery tank, use Refrigerant recovery/recycling recharging equipment and Refrigerant Identifier.**
- **Use only specified oil for the HFC-134a (R-134a) A/C system and HFC-134a (R-134a) components. Compressor malfunction is likely to occur if oil other than that specified is used.**
- **The specified HFC-134a (R-134a) oil rapidly absorbs moisture from the atmosphere. The following handling precautions must be observed:**
 - **Cap (seal) the component immediately to minimize the entry of moisture from the atmosphere when removing refrigerant components from a vehicle.**
 - **Do not remove the caps (unseal) until just before connecting the components when installing refrigerant components to a vehicle. Connect all refrigerant loop components as quickly as possible to minimize the entry of moisture into system.**
 - **Use only the specified oil from a sealed container. Reseal containers of oil immediately. Oil becomes moisture saturated and should not be used without proper sealing.**
 - **Do not allow oil to come in contact with styrene foam parts. Damage may result.**

GENERAL REFRIGERANT PRECAUTION

WARNING:

- **Do not breathe A/C refrigerant and oil vapor or mist. Exposure may irritate eyes, nose and throat. Remove HFC-134a (R-134a) from the A/C system, using certified service equipment meeting requirements of SAE J-2210 [HFC-134a (R-134a) recycling equipment] or J-2209 [HFC-134a (R-134a) recovery equipment]. Ventilate work area before resuming service if accidental system discharge occurs. Additional health and safety information may be obtained from refrigerant and oil manufacturers.**
- **Do not release refrigerant into the air. Use approved recovery/recycling recharging equipment to capture the refrigerant each time an air conditioning system is discharged.**
- **Always wear eye and hand protection (goggles and gloves) when working with any refrigerant or air conditioning system.**
- **Do not store or heat refrigerant containers above 52°C (126°F).**
- **Do not heat a refrigerant container with an open flame; Place the bottom of the container in a warm pail of water if container warming is required.**
- **Do not intentionally drop, puncture or incinerate refrigerant containers.**
- **Do not refrigerant away from open flames; poisonous gas is produced if refrigerant burns.**
- **Refrigerant displaces oxygen; therefore be certain to work in well ventilated areas to prevent suffocation.**
- **Do not pressure test or leakage test HFC-134a (R-134a) service equipment and/or vehicle air conditioning systems with compressed air during repair. Some mixtures of air and HFC-134a (R-134a) have been shown to be combustible at elevated pressures. These mixtures, if ignited, may cause injury or property damage. Additional health and safety information may be obtained from refrigerant manufacturers.**

O-RING AND REFRIGERANT CONNECTION

PRECAUTIONS

< PRECAUTION >

[AUTOMATIC AIR CONDITIONING]

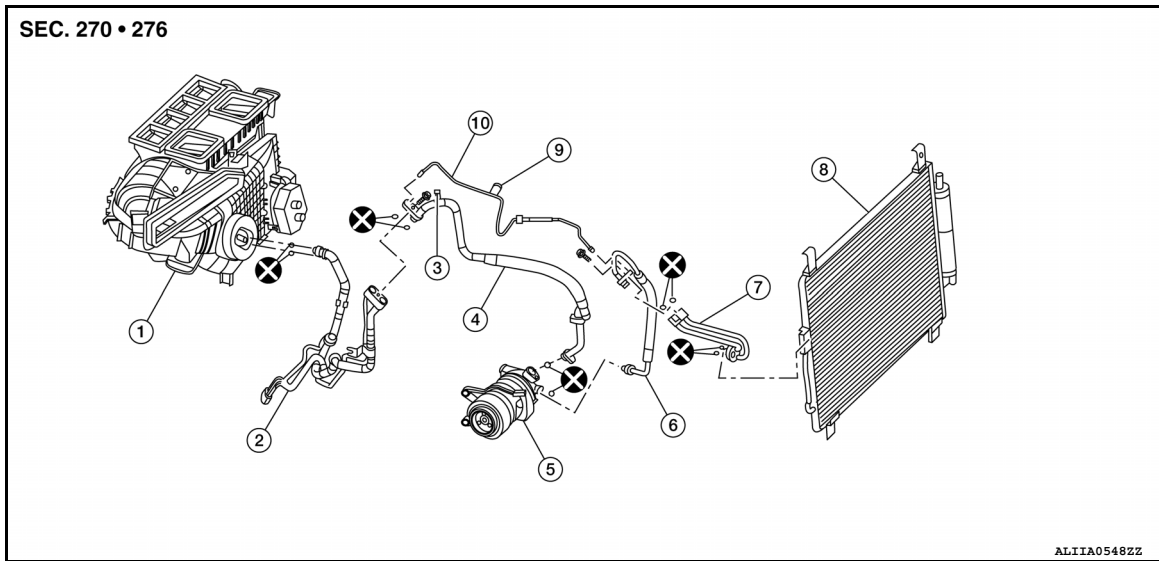

- | | | |
|--|--|--------------------------------|
| 1. Front heating and cooling unit assembly | 2. High-pressure and low-pressure pipe | 3. Low-pressure service port |
| 4. Low-pressure flexible hose | 5. Compressor | 6. High-pressure flexible hose |
| 7. Condenser pipe assembly | 8. Condenser | 9. High-pressure service port |
| 10. High-pressure pipe | | |

A new type of refrigerant connection has been introduced to all refrigerant lines except the following locations:

- Expansion valve to evaporator
- Refrigerant pressure sensor to liquid tank

WARNING:

Check that all refrigerant is discharged into the recycling equipment and the pressure in the system is less than atmospheric pressure. Then gradually loosen the discharge side hose fitting and remove it.

CAUTION:

Observe the following when replacing or cleaning refrigerant cycle components.

- Store it in the same way as it is when mounted on the vehicle when the compressor is removed. Failure to do so will cause oil to enter the low-pressure chamber.
- Always use a torque wrench and a back-up wrench when connecting tubes.
- Immediately plug all openings to prevent entry of dust and moisture after disconnecting tubes.
- Connect the pipes at the final stage of the operation when installing an air conditioner in the vehicle. Do not remove the seal caps of pipes and other components until just before required for connection.
- Allow components stored in cool areas to warm to working area temperature before removing seal caps. This prevents condensation from forming inside A/C components.
- Remove moisture thoroughly from the refrigeration system before charging the refrigerant.
- Always replace used O-rings.
- Apply oil to circle of the O-rings shown in illustration when connecting tube. Be careful not to apply oil to threaded portion.
- O-ring must be closely attached to the groove portion of tube.
- Be careful not to damage O-ring and tube when replacing the O-ring.
- Connect tube until a click can be heard. Then tighten the nut or bolt by hand. Check that the O-ring is installed to tube correctly.

PRECAUTIONS

< PRECAUTION >

[AUTOMATIC AIR CONDITIONING]

- Perform leakage test and make sure that there is no leakage from connections after connecting line. Disconnect that line and replace the O-ring when the refrigerant leaking point is found. Then tighten connections of seal seat to the specified torque.

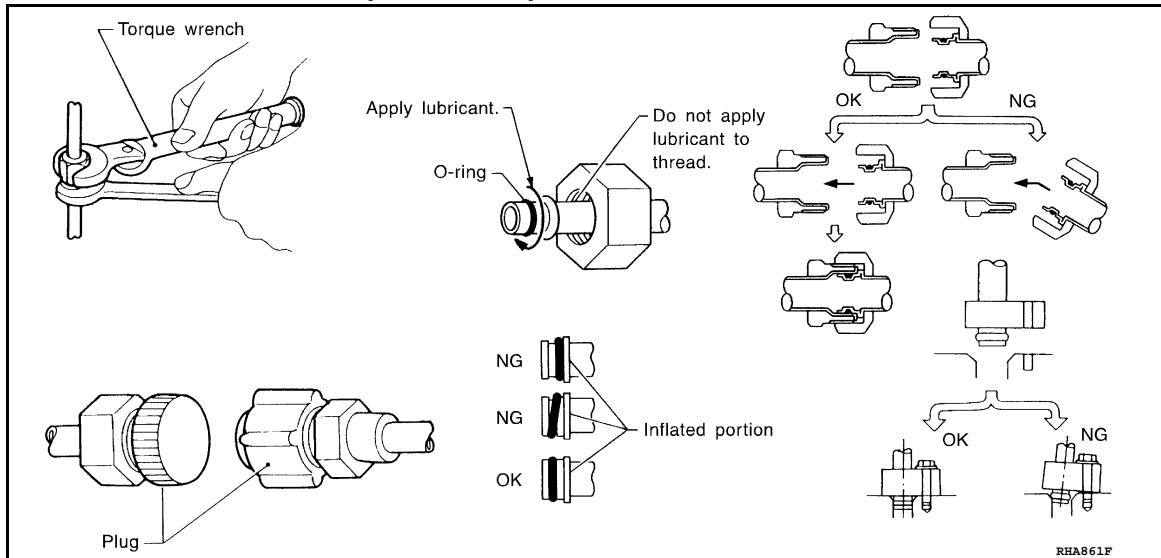

CONTAMINATED REFRIGERANT

Take appropriate steps shown below if a refrigerant other than pure HFC-134a (R-134a) is identified in a vehicle:

- Explain to the customer that environmental regulations prohibit the release of contaminated refrigerant into the atmosphere.
- Explain that recovery of the contaminated refrigerant could damage service equipment and refrigerant supply.
- Suggest the customer return the vehicle to the location of previous service where the contamination may have occurred.
- In case of repairing, recover the refrigerant using only **dedicated equipment and containers**. **Do not recover contaminated refrigerant into the existing service equipment**. Contact a local refrigerant product retailer for available service if the facility does not have dedicated recovery equipment. This refrigerant must be disposed of in accordance with all federal and local regulations. In addition, replacement of all refrigerant system components on the vehicle is recommended.
- The air conditioner warranty is void if the vehicle is within the warranty period. Please contact Nissan Customer Affairs for further assistance.

COMPRESSOR

CAUTION:

- Plug all openings to prevent moisture and foreign matter from entering.
- Store it in the same way as it is when mounted on the car when the compressor is removed.
- Follow "Maintenance of Oil Quantity in Compressor" exactly when replacing or repairing compressor. Refer to [HA-25, "Description"](#).
- Keep friction surfaces between clutch and pulley clean. Wipe it off by using a clean waste cloth moistened with thinner if the surface is contaminated with oil.
- Turn the compressor shaft by hand more than five turns in both directions after compressor service operation. This distributes oil equally inside the compressor. Let the engine idle and operate the compressor for one hour after the compressor is installed.
- Apply voltage to the new one and check for normal operation after replacing the compressor magnet clutch.

LEAK DETECTION DYE

CAUTION:

- The A/C system contains a fluorescent leak detection dye used for locating refrigerant leakages. An ultraviolet (UV) lamp is required to illuminate the dye when inspecting for leakages.
- Always wear fluorescence enhancing UV safety goggles to protect eyes and enhance the visibility of the fluorescent dye.
- The fluorescent dye leak detector is not a replacement for an electrical leak detector (SST: J-41995). The fluorescent dye leak detector should be used in conjunction with an electrical leak detector (SST: J-41995) to pinpoint refrigerant leakages.

PRECAUTIONS

[AUTOMATIC AIR CONDITIONING]

< PRECAUTION >

- Read and follow all manufacturer's operating instructions and precautions prior to performing the work for the purpose of safety and customer's satisfaction.
- A compressor shaft seal should not necessarily be repaired because of dye seepage. The compressor shaft seal should only be repaired after confirming the leakage with an electrical leak detector (SST: J-41995).
- Always remove any remaining dye from the leakage area after repairs are completed to avoid a misdiagnosis during a future service.
- Do not allow dye to come into contact with painted body panels or interior components. Clean immediately with the approved dye cleaner if dye is spilled. Fluorescent dye left on a surface for an extended period of time cannot be removed.
- Do not spray the fluorescent dye cleaning agent on hot surfaces (engine exhaust manifold, etc.).
- Do not use more than one refrigerant dye bottle [1/4 ounce (7.4 cc)] per A/C system.
- Leak detection dyes for HFC-134a (R-134a) and CFC-12 (R-12) A/C systems are different. Do not use HFC-134a (R-134a) leak detection dye in CFC-12 (R-12) A/C system or CFC-12 (R-12) leak detection dye in HFC-134a (R-134a) A/C system or A/C system damage may result.
- The fluorescent properties of the dye remains for three or more years unless a compressor malfunction occurs.

NOTE:

Identification

- Vehicles with factory installed fluorescent dye have a green label.
- Vehicles without factory installed fluorescent dye have a blue label.

Precaution for Service Equipment

INFOID:000000008929709

MANIFOLD GAUGE SET

Be certain that the gauge face indicates R-134a or 134a. Make sure the gauge set has 1/2"-16 ACME threaded connections for service hoses. Confirm the set has been used only with refrigerant HFC-134a (R-134a) along with specified oil.

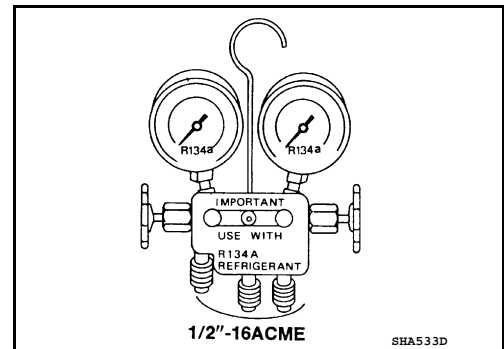

SERVICE HOSES

Be certain that the service hoses display the markings described (colored hose with black stripe). All hoses must include positive shut-off devices (either manual or automatic) near the end of the hoses opposite the manifold gauge.

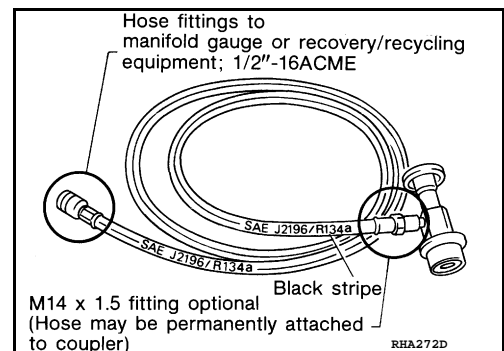

SERVICE COUPLERS

PRECAUTIONS

< PRECAUTION >

Do not attempt to connect HFC-134a (R-134a) service couplers to a CFC-12 (R-12) A/C system. The HFC-134a (R-134a) couplers will not properly connect to the CFC-12 (R-12) system. However, if an improper connection is attempted, discharging and contamination may occur.

Shut-off valve rotation	A/C service valve
Clockwise	Open
Counterclockwise	Close

[AUTOMATIC AIR CONDITIONING]

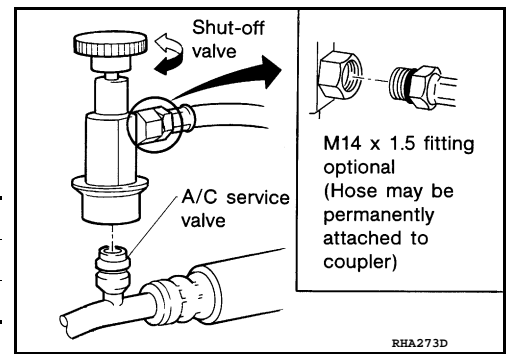

PREPARATION

< PREPARATION >

[AUTOMATIC AIR CONDITIONING]

PREPARATION

PREPARATION

Special Service Tool

INFOID:000000008929711

The actual shapes of Kent-Moore tools may differ from those of special service tools illustrated here.

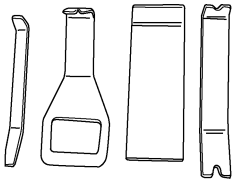
Tool number (Kent-Moore No.) Tool name	Description
— (J-46534) Trim Tool Set <div style="text-align: center;">  <p>AWJIA0483ZZ</p> </div>	Removing trim components

Commercial Service Tool

INFOID:000000008929712

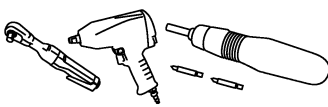
(Kent-Moore No.) Tool name	Description
(—) Power tool <div style="text-align: center;">  <p>PIIB1407E</p> </div>	Loosening nuts, screws and bolts

A

B

C

D

E

F

G

H

HAC

J

K

L

M

N

O

P

COMPONENT PARTS

< SYSTEM DESCRIPTION >

[AUTOMATIC AIR CONDITIONING]

SYSTEM DESCRIPTION

COMPONENT PARTS

FRONT AUTOMATIC AIR CONDITIONING SYSTEM

FRONT AUTOMATIC AIR CONDITIONING SYSTEM : Component Parts Location

INFOID:000000008901664

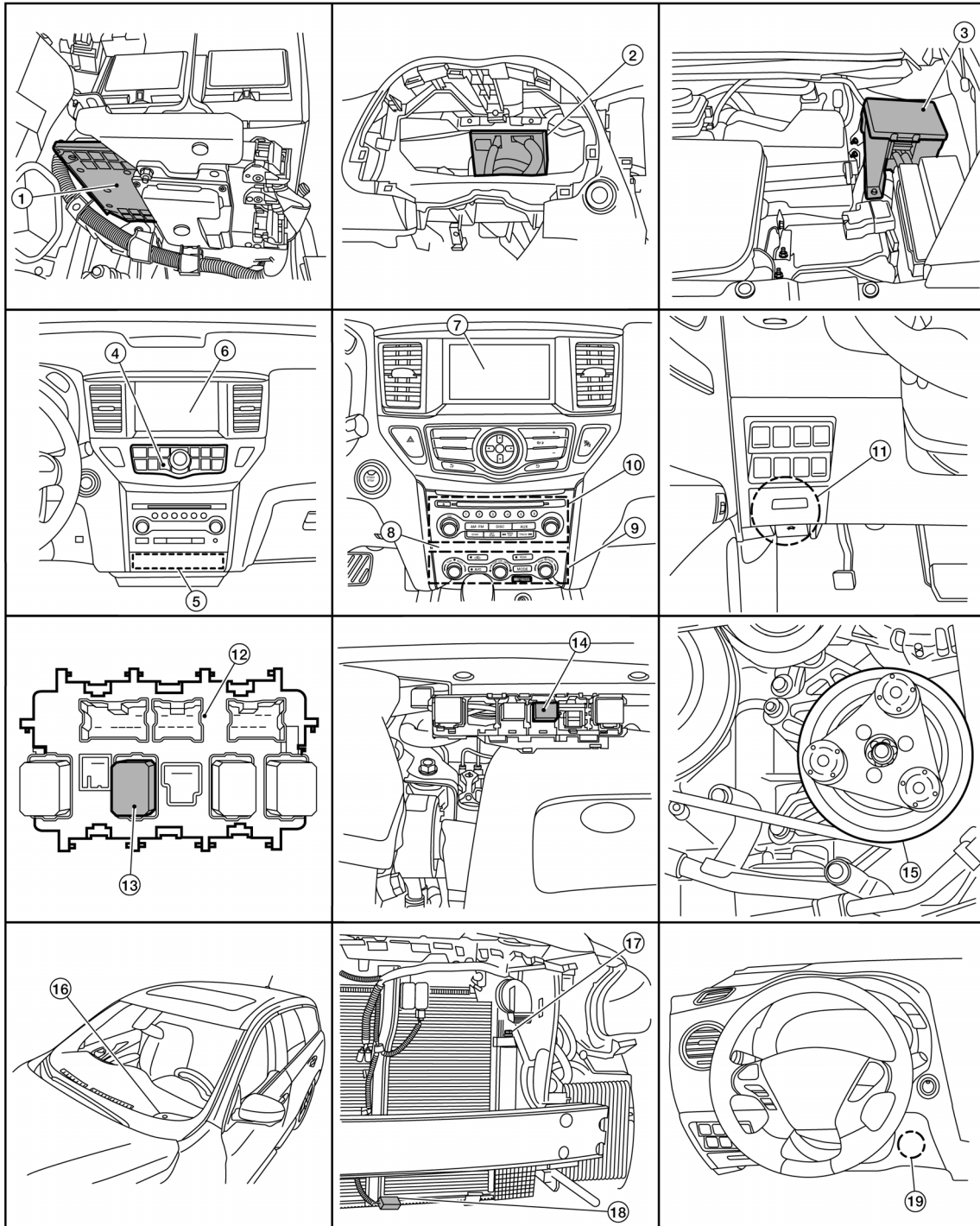

ALL11A06822Z

COMPONENT PARTS

< SYSTEM DESCRIPTION >

[AUTOMATIC AIR CONDITIONING]

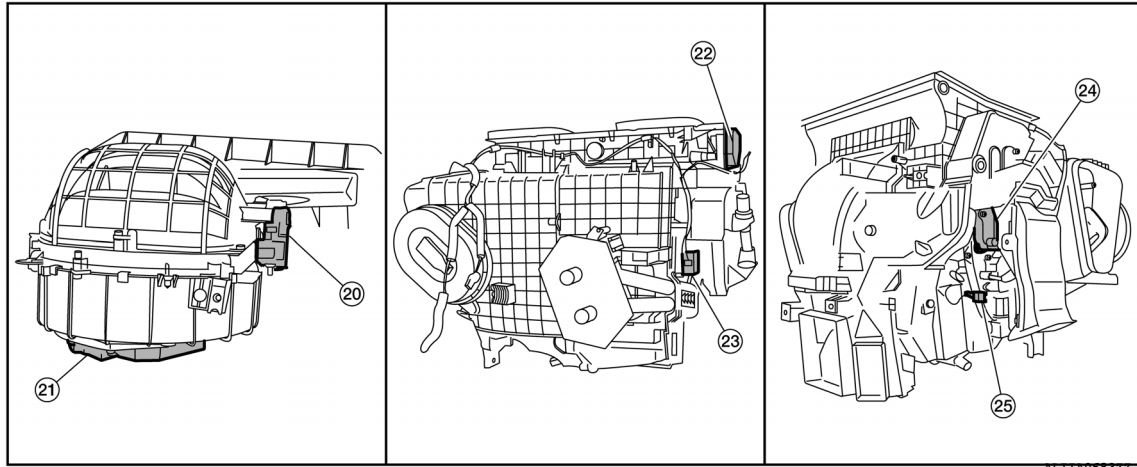

- | | | |
|---|--|---|
| 1. ECM | 2. BCM (view with combination meter removed) | 3. IPDM E/R. |
| 4. A/C switch assembly (with base audio system) | 5. A/C auto amp. | 6. A/C display unit (with base audio system) |
| 7. Display unit (except base audio system) | 8. A/C and AV switch assembly (except base audio system) | 9. A/C auto amp. |
| 10. AV control unit | 11. Fuse block (J/B) | 12. Fuse block (J/B) |
| 13. Front blower motor relay | 14. Accessory relay-2 | 15. A/C compressor |
| 16. Sunload sensor | 17. Refrigerant pressure sensor (view with front bumper fascia removed) | 18. Ambient sensor |
| 19. In-vehicle sensor | 20. Intake door motor (view with fresh air intake duct removed from vehicle) | 21. Front blower motor |
| 22. Mode door motor (front) (view with front A/C assembly removed from vehicle) | 23. Air mix door motor (driver side) | 24. Air mix door motor (passenger side) (view with front A/C assembly removed from vehicle) |
| 25. Intake sensor | | |

FRONT AUTOMATIC AIR CONDITIONING SYSTEM : Component Description

INFOID:000000008901665

Component	Description
A/C and AV switch assembly (except base audio system)	Front A/C control operation signal is transmitted from the A/C and AV switch assembly to AV control unit via communication line.
A/C display unit (with base audio system)	The A/C display unit indicates operation status of the front and rear automatic air conditioning system.
A/C switch assembly (with base audio system)	The A/C switch assembly controls the operation of the A/C and heating system based on inputs from the temperature control knob, the mode switches, the blower control dial, the ambient temperature sensor, the intake sensor, and inputs received from the ECM via CAN communication. Diagnosis of the A/C switch assembly can be performed using the CONSULT. There is no self-diagnostic feature available.
A/C auto amp.	A/C auto amp. controls front automatic air conditioning system by inputting and calculating signals from each sensor and each switch.
A/C Compressor	Vaporized refrigerant is drawn into the A/C compressor from the evaporator, where it is compressed to a high pressure, high temperature vapor. The hot, compressed vapor is then discharged to the condenser.

COMPONENT PARTS

< SYSTEM DESCRIPTION >

[AUTOMATIC AIR CONDITIONING]

Component	Description
Air mix door motor (Driver side)	The air mix door controls the mix of hot or cold air that enters the ventilation system. It is controlled by the A/C auto amp. based on the position of the temperature dial. The air mix door motor receives position commands from the A/C auto amp. and reports actual door position back via an LCU (Local Control Unit) installed inside the motor. Commands and responses are sent across the LIN (Local Interconnect Network) to each motor simultaneously, with each motor having its own unique address, thereby only responding to requests sent to its specific address. The LCU reads the door position from a Position Balanced Resistor (PBR), also part of the motor, and returns that information to the A/C auto amp. The LCU switches the polarity of the circuits connected to the DC motor to drive the motor forward or backward as requested by the front air control. If the air mix door moves to a position less than 5% or more than 95% of its expected or allowed positions, the A/C auto amp. will set a DTC.
Air mix door motor (Passenger side)	The air mix door controls the mix of hot or cold air that enters the ventilation system. It is controlled by the A/C auto amp. based on the position of the temperature dial. The air mix door motor receives position commands from the A/C auto amp. and reports actual door position back via an LCU (Local Control Unit) installed inside the motor. Commands and responses are sent across the LIN (Local Interconnect Network) to each motor simultaneously, with each motor having its own unique address, thereby only responding to requests sent to its specific address. The LCU reads the door position from a Position Balanced Resistor (PBR), also part of the motor, and returns that information to the A/C auto amp. The LCU switches the polarity of the circuits connected to the DC motor to drive the motor forward or backward as requested by the front air control. If the air mix door moves to a position less than 5% or more than 95% of its expected or allowed positions, the A/C auto amp. will set a DTC.
Ambient sensor	The ambient sensor measures the temperature of the air surrounding the vehicle. The sensor uses a thermistor which is sensitive to the change in temperature. The electrical resistance of the thermistor decreases as temperature increases.
AV control unit	AV control unit transmits A/C and AV switch assembly operation signal to A/C auto amp. via CAN communication line.
BCM	BCM transmits blower motor ON signal to the front and rear blower motor relays.
Display unit (except base audio system)	The display unit indicates operation status of the front and rear automatic air conditioning system.
ECM	The ECM sends a compressor ON request to the IPDM E/R based on the status of engine operation and load as well as refrigerant pressure information. If all the conditions are met for A/C operation, the ECM transmits the compressor ON request to the IPDM E/R. The ECM shares the refrigerant pressure sensor signal, engine RPM, and engine coolant temperature with the A/C auto amp. via CAN communication line.
Front blower motor	The front blower motor varies the speed at which the air flows through the ventilation system.
Front blower motor relay	The front blower motor relay controls the flow of current to fuse 17 and 27 in the Fuse Block (J/B). The relay is connected directly to ground, and is controlled by the BCM.
Fuse block (J/B)	Located in the passenger compartment, behind the left lower IP, the Fuse Block (J/B) contains the front blower motor relay and several fuses required for the air conditioner control system.
IPDM E/R	A/C relay is integrated in IPDM E/R. IPDM E/R operates A/C relay when A/C compressor request signal is received from ECM via CAN communication line.
Intake door motor	The intake door motor controls the position of the intake door. Fresh air is allowed to enter the cabin in one position, and recirculated inside air is allowed to enter in the other position. At times the A/C auto amp. may command partial fresh or recirculation based on evaporator or coolant temperatures. The intake door motor receives position commands from the front air control and reports actual door position back via an LCU (Local Control Unit) installed inside the motor. Commands and responses are sent across the LIN (Local Interconnect Network) to each motor simultaneously, with each motor having its own unique address, thereby only responding to requests sent to its specific address. The LCU reads the door position from a Position Balanced Resistor (PBR), also part of the motor, and returns that information to the front air control. The LCU switches the polarity of the circuits connected to the DC motor to drive the motor forward or backward as requested by the front air control. If the recirculation door moves to a position less than 5% or more than 95% of its expected or allowed positions, the front air control will set a DTC.
Intake sensor	Intake sensor measures temperature of front evaporator fin temperature. The sensor uses a thermistor which is sensitive to the change in temperature. The electrical resistance of the thermistor decreases as temperature increases.

COMPONENT PARTS

< SYSTEM DESCRIPTION >

[AUTOMATIC AIR CONDITIONING]

Component	Description
In-vehicle sensor	In-vehicle sensor measures temperature of intake air that flows through aspirator to passenger room. The sensor uses a thermistor which is sensitive to the change in temperature. The electrical resistance of the thermistor decreases as temperature increases.
Mode door motor (Front)	The mode door (front) controls the direction the conditioned air passes through the ventilation system. Through a series of levers and gears, the mode door controls the defrost door, the foot door, and the vent door. There are 5 preset positions: VENT, B/L, FOOT, D/F and DEF. The FOOT position can be set to allow some airflow through to the defroster vent or to completely block the defroster vent using the CONSULT. The mode door motor receives position commands from the A/C auto amp. and reports actual door position back via an LCU (Local Control Unit) installed inside the motor. Commands and responses are sent across the LIN (Local Interconnect Network) to each motor simultaneously, with each motor having its own unique address, thereby only responding to requests sent to its specific address. The LCU reads the door position from a Position Balanced Resistor (PBR), also part of the motor, and returns that information to the front air control. The LCU switches the polarity of the circuits connected to the DC motor to drive the motor forward or backward as requested by the front air control. The mode door has 5 expected positions and, therefore, can set up to 5 DTCs if the expected position is not reported back to the A/C auto amp.
Refrigerant pressure sensor	Refer to EC-28. "Refrigerant Pressure Sensor" .
Sunload sensor	Sunload sensor measures sunload amount. This sensor converts sunload amount to voltage signal by photodiode and transmits to A/C auto amp.

REAR AUTOMATIC AIR CONDITIONING SYSTEM

A
B
C
D
E
F
G
H
I
J
K
L
M
N
O
P

HAC

COMPONENT PARTS

< SYSTEM DESCRIPTION >

[AUTOMATIC AIR CONDITIONING]

REAR AUTOMATIC AIR CONDITIONING SYSTEM : Component Parts Location

INFOID:000000008901666

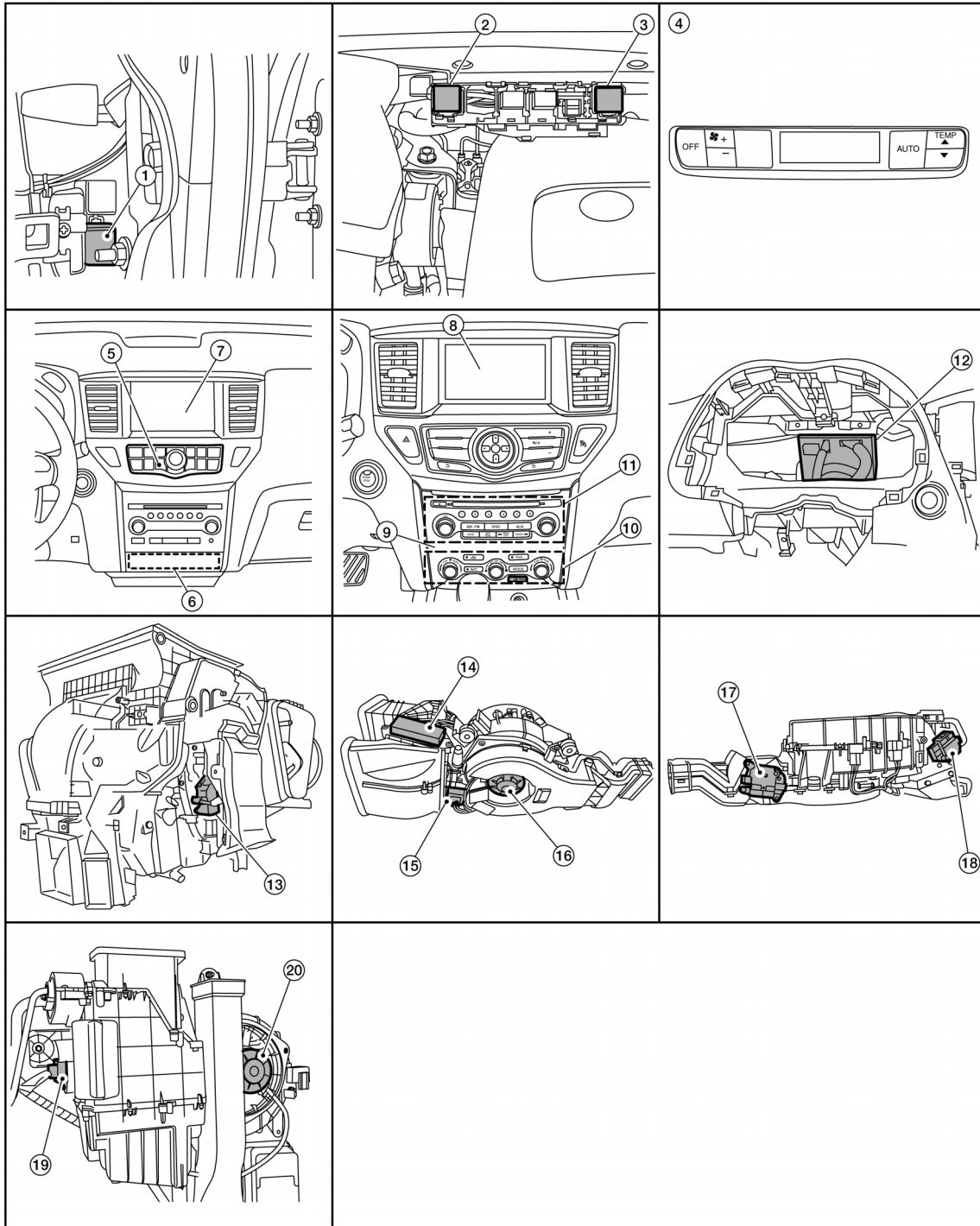

AL11A0684ZZ

- | | | |
|---|---|--|
| 1. Rear blower motor relay (view with instrument panel removed) | 2. PTC relay 1 | 3. PTC relay 2 |
| 4. Rear air control | 5. A/C switch assembly (with base audio system) | 6. A/C auto amp. |
| 7. A/C display unit (with base audio system) | 8. Display unit (except base audio system) | 9. A/C and AV switch assembly (except base audio system) |
| 10. A/C auto amp. | 11. AV control unit (except base audio system) | 12. BCM (view with combination meter removed) |

COMPONENT PARTS

< SYSTEM DESCRIPTION >

[AUTOMATIC AIR CONDITIONING]

- | | | |
|---|---|----------------------------------|
| 13. Air mix door motor (rear) (view with front A/C assembly removed from vehicle) | 14. PTC heater (view with rear booster assembly removed from vehicle) | 15. Rear blower motor resistor 1 |
| 16. Rear blower motor 1 | 17. Rear shut-off door motor (view with rear booster assembly removed from vehicle) | 18. Mode door motor (rear) |
| 19. Rear blower motor resistor 2 (view with luggage side lower finisher RH removed) | 20. Rear blower motor 2 | |

A
B
C
D

REAR AUTOMATIC AIR CONDITIONING SYSTEM : Component Description

INFOID:000000008901667

Component	Description
A/C auto amp.	A/C auto amp. controls the automatic air conditioning system by inputting and calculating signals from each sensor and each switch.
A/C display unit (with base audio system)	The A/C display unit indicates operation status of the front and rear automatic air conditioning system.
A/C switch assembly (with base audio system)	The A/C switch assembly controls the operation of the A/C and heating system based on inputs from the temperature control knob, the mode switches, the blower control dial, the ambient temperature sensor, the intake sensor, and inputs received from the ECM via CAN communication. Diagnosis of the A/C switch assembly can be performed using the CONSULT. There is no self-diagnostic feature available.
A/C and AV switch assembly (except base audio system)	Rear air control operation signal is transmitted from the A/C and AV switch assembly to AV control unit via communication line.
Air mix door motor (Rear)	The air mix door (rear) controls the mix of hot or cold air that enters the ventilation system. It is controlled by the A/C auto amp. based on the position of the temperature dial. The air mix door motor (rear) receives position commands from the A/C auto amp. and reports actual door position back via an LCU (Local Control Unit) installed inside the motor. Commands and responses are sent across the LIN (Local Interconnect Network) to each motor simultaneously, with each motor having its own unique address, thereby only responding to requests sent to its specific address. The LCU reads the door position from a Position Balanced Resistor (PBR), also part of the motor, and returns that information to the A/C auto amp. The LCU switches the polarity of the circuits connected to the DC motor to drive the motor forward or backward as requested by the front air control. If the air mix door (rear) moves to a position less than 5% or more than 95% of its expected or allowed positions, the A/C auto amp. will set a DTC.
AV control unit	AV control unit transmits A/C and AV switch assembly operation signal to A/C auto amp. via CAN communication line.
BCM	BCM transmits blower motor ON signal to the rear blower motor relay.
Display unit (except base audio system)	The display unit indicates operation status of the front and rear automatic air conditioning system.
Mode door motor (Rear)	The mode door (rear) controls the direction the conditioned air passes through the ventilation system. The mode door motor (rear) receives position commands from the A/C auto amp. and reports actual door position back via an LCU (Local Control Unit) installed inside the motor. Commands and responses are sent across the LIN (Local Interconnect Network) to each motor simultaneously, with each motor having its own unique address, thereby only responding to requests sent to its specific address. The LCU reads the door position from a Position Balanced Resistor (PBR), also part of the motor, and returns that information to the front air control. The LCU switches the polarity of the circuits connected to the DC motor to drive the motor forward or backward as requested by the A/C auto amp. The mode door has 2 expected positions and, therefore, can set up to 2 DTCs if the expected position is not reported back to the A/C auto amp.
PTC heater	The positive temperature coefficient (PTC) heater provides supplemental heat to the rear seating by warming the air as it flows through its electrically controlled heating grid.
PTC heater relay	The PTC heater relay controls the flow of current to the PTC heater. The relay is controlled by the A/C auto amp.
Rear blower motor 1	The rear blower motor-1 varies the speed at which the air flows through the ventilation system.

HAC

J
K
L
M
N
O
P

COMPONENT PARTS

< SYSTEM DESCRIPTION >

[AUTOMATIC AIR CONDITIONING]

Component	Description
Rear blower motor 2	The rear blower motor-2 varies the speed at which the air flows through the ventilation system.
Rear blower motor relay	The rear blower motor relay controls the flow of current to the rear blower motor. The relay is connected directly to ground, and is controlled by the BCM.
Rear shut-off door motor	The rear shut-off door controls the conditioned air through the ventilation system. The rear shut-off door motor receives position commands from the A/C auto amp. and reports actual door position back via an LCU (Local Control Unit) installed inside the motor. Commands and responses are sent across the LIN (Local Interconnect Network) to each motor simultaneously, with each motor having its own unique address, thereby only responding to requests sent to its specific address. The LCU reads the door position from a Position Balanced Resistor (PBR), also part of the motor, and returns that information to the front air control. The LCU switches the polarity of the circuits connected to the DC motor to drive the motor forward or backward as requested by the A/C auto amp. The mode door has 2 expected positions and therefore will set a DTC if the expected position is not reported back to the A/C auto amp.

SYSTEM

< SYSTEM DESCRIPTION >

[AUTOMATIC AIR CONDITIONING]

SYSTEM

FRONT AUTOMATIC AIR CONDITIONING SYSTEM

FRONT AUTOMATIC AIR CONDITIONING SYSTEM : System Diagram

INFOID:000000008901670

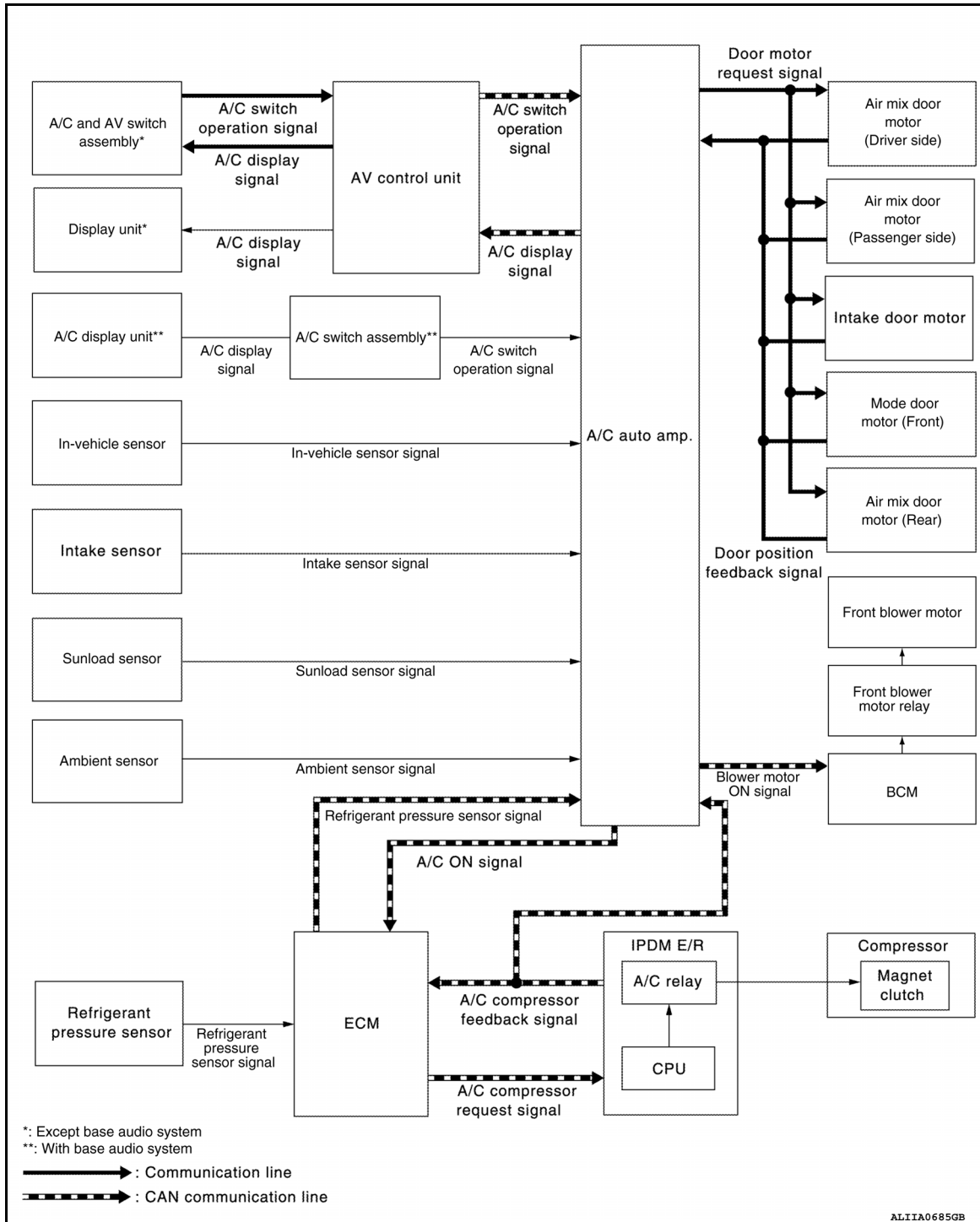

FRONT AUTOMATIC AIR CONDITIONING SYSTEM : System Description

INFOID:000000008901671

- Front automatic air conditioning system is controlled by each function of A/C auto amp., ECM, IPDM E/R and BCM.

Control by A/C auto amp.

- [HAC-21. "FRONT AUTOMATIC AIR CONDITIONING SYSTEM : Air Flow Control"](#)
- [HAC-22. "FRONT AUTOMATIC AIR CONDITIONING SYSTEM : Air Inlet Control"](#)

A
B
C
D
E
F
G
H
HAC
J
K
L
M
N
O
P

SYSTEM

< SYSTEM DESCRIPTION >

[AUTOMATIC AIR CONDITIONING]

- [HAC-22, "FRONT AUTOMATIC AIR CONDITIONING SYSTEM : Air Outlet Control"](#)
- [HAC-23, "FRONT AUTOMATIC AIR CONDITIONING SYSTEM : Compressor Control"](#)
- [HAC-24, "FRONT AUTOMATIC AIR CONDITIONING SYSTEM : Door Control"](#)
- [HAC-26, "FRONT AUTOMATIC AIR CONDITIONING SYSTEM : Temperature Control"](#)
- [HAC-20, "FRONT AUTOMATIC AIR CONDITIONING SYSTEM : Intelligent Key Interlock Function"](#)
- Correction for input value of each sensor

Ambient sensor (setting temperature correction)

- A/C auto amp. controls passenger room temperature so that the optimum level always matches the temperature level that the passenger may feel. Correction is applied to the target temperature that is set using temperature control dial, according to ambient temperature detected by ambient sensor.

In-vehicle sensor [in-vehicle temperature (front side) correction]

- Passenger room temperature (front side) detected by in-vehicle sensor is corrected for each front air conditioning control (driver side and passenger side).

Intake sensor (intake temperature correction)

- A/C auto amp. performs correction to change recognition intake temperature of A/C auto amp. quickly when difference is large between recognition intake temperature and intake temperature detected by intake temperature sensor. The correction is performed to change recognition intake temperature slowly when difference is small.

Sunload sensor (sunload amount correction)

- Sunload amount detected by sunload sensor is corrected for each air conditioning control.
- A/C auto amp. performs correction to change recognition sunload amount of A/C auto amp. slowly when sunload amount changes quickly, for example when entering or exiting a tunnel.

Control by ECM

- Cooling fan control
Refer to [EC-39, "COOLING FAN CONTROL : System Description"](#).
- Air conditioning cut control
Refer to [EC-37, "AIR CONDITIONING CUT CONTROL : System Description"](#).

Control by IPDM E/R

- Relay control
Refer to [PCS-6, "RELAY CONTROL SYSTEM : System Description"](#).
- Cooling fan control
Refer to [EC-39, "COOLING FAN CONTROL : System Description"](#).

Control by BCM

- Intelligent Key interlock function
Refer to [HAC-20, "FRONT AUTOMATIC AIR CONDITIONING SYSTEM : Intelligent Key Interlock Function"](#).
- Relay control
Refer to [BCS-7, "BODY CONTROL SYSTEM : System Description"](#).
- Vehicles with base audio system, the A/C switch assembly transmits the commands for front automatic air conditioning system operation to the A/C auto amp. via communication line. A/C auto amp. transmits each indication information to the A/C display unit via communication line. A/C display unit displays each indication information that is received.
- Vehicles without base audio system, the A/C and AV switch assembly transmits the commands for front automatic air conditioning system operation to the AV control unit via communication line, then AV control unit transmits the commands to A/C auto amp. via CAN communication. A/C auto amp. transmits each indication information to AV control unit via CAN communication. AV control unit displays each indication information that is received.

FRONT AUTOMATIC AIR CONDITIONING SYSTEM : Intelligent Key Interlock Function

INFOID:000000008901672

DESCRIPTION

- Setting value of air conditioning system when ignition switch is previously OFF can be memorized for each Intelligent Key. Air conditioning system is automatically operated by the setting value.

NOTE:

- Setting value can be memorized for up to 3 Intelligent Keys.
- Interlock items are as per the following table.

SYSTEM

< SYSTEM DESCRIPTION >

[AUTOMATIC AIR CONDITIONING]

Operation	Conditions
A/C and AV switch assembly	AUTO switch (ON / OFF)
	Setting temperature (Setting value)
	Air flow (Setting value)
	Air inlet (FRE / REC)
	Air outlet (VENT / B/L / FOOT / D/F / DEF)
"Climate" menu screen	"A/C" (ON / OFF)
	"DUAL" (ON / OFF)

Operation Description

Memory

1. Unlock door using Intelligent Key or driver door request switch.
2. BCM transmits Key ID signal to A/C auto amp. via CAN communication line.
3. When ignition switch turns OFF, A/C auto amp. memorizes setting information (setting temperature, air inlet status, and others) of air conditioning system to memory for each Key ID.

Readout

1. Unlock door using Intelligent Key or driver door request switch.
2. BCM transmits Key ID signal to A/C auto amp. via CAN communication line.
3. When ignition switch turns ON, A/C auto amp. operates automatically air conditioning system according to setting information of Key ID that is received.

NOTE:

When Intelligent Key interlock function operates, "Connection with the key has been done." is displayed.

FRONT AUTOMATIC AIR CONDITIONING SYSTEM : Air Flow Control

INFOID:000000008901673

HAC

DESCRIPTION

- A/C auto amp. changes duty ratio of blower motor drive signal and controls air flow continuously. When air flow is increased, duty ratio of front blower motor control signal gradually increases to prevent a sudden increase in air flow.
- In addition to manual control and automatic control, air flow control is consist of starting fan speed control, low coolant temperature starting control, high in-vehicle temperature starting control and fan speed control at door motor operation

AUTOMATIC AIR FLOW CONTROL

- A/C auto amp. decides target air flow depending on target air mix door (front) opening angle.
- A/C auto amp. changes duty ratio of front blower motor control signal and controls the air flow continuously so that air flow matches the target air flow.
- When air outlet is VENT or B/L, the minimum air flow is changed depending on sunload.

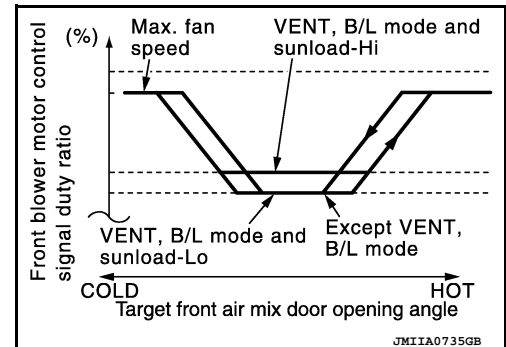

STARTING AIR FLOW CONTROL

SYSTEM

< SYSTEM DESCRIPTION >

[AUTOMATIC AIR CONDITIONING]

- When front blower motor is activated, A/C auto amp. gradually increases duty ratio of front blower motor control signal to prevent a sudden increase in discharge air flow.
- It takes approximately 8 seconds for air flow to reach HI from LOW.

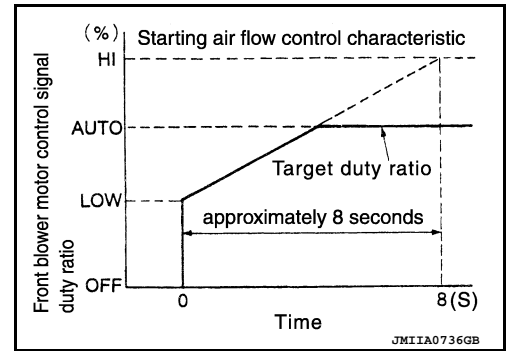

LOW COOLANT TEMPERATURE STARTING CONTROL

If the engine coolant temperature is 56°C (133°F) or less, to prevent a cold discharged air flow, A/C auto amp. suspends front blower motor activation for the maximum 150 seconds depending on target air mix door (front) opening angle. After this, front blower motor control signal is increased gradually, and front blower motor is activated.

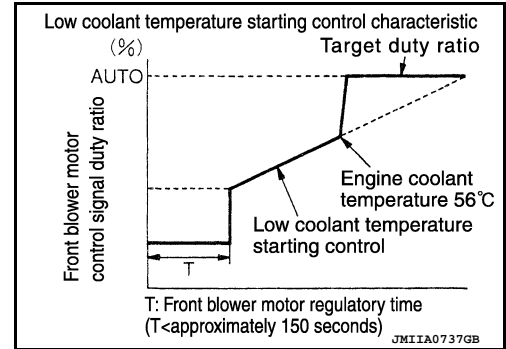

HIGH IN-VEHICLE TEMPERATURE STARTING CONTROL

When front evaporator fin temperature is high [intake sensor value is 35°C (95°F) or more], to prevent a hot discharged air flow, A/C auto amp. suspends front blower motor activation for approximately 3 seconds so that front evaporator is cooled by refrigerant.

FAN SPEED CONTROL AT DOOR MOTOR OPERATION

When mode door motor (front) is activated while air flow is more than the specified value, A/C auto amp. reduces fan speed temporarily so that mode door (front) moves smoothly.

FRONT AUTOMATIC AIR CONDITIONING SYSTEM : Air Inlet Control

INFOID:000000008901674

The intake door is automatically controlled by the temperature setting, ambient temperature, in-vehicle temperature, intake temperature, amount of sunload and ON/OFF operation of the compressor. Intake door automatic control selects FRE, 20% FRE, or REC depending on a target air mix door (front) opening angle, based on in-vehicle temperature, ambient temperature, and sunload.

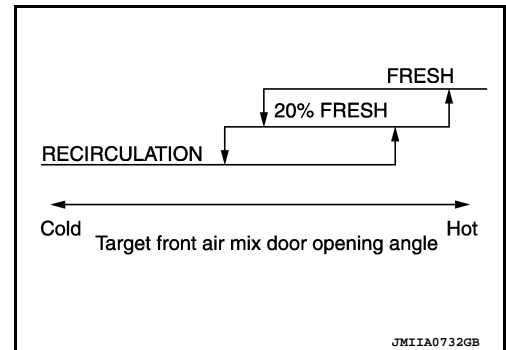

FRONT AUTOMATIC AIR CONDITIONING SYSTEM : Air Outlet Control

INFOID:000000008901675

- While air outlet is in automatic control, A/C auto amp. selects the mode door (front) position depending on a target air mix door (front) angle and outlet air temperature calculated from sunload.
- If ambient temperature is excessively low, D/F is selected to prevent windshield fogging when air outlet is set to FOOT.

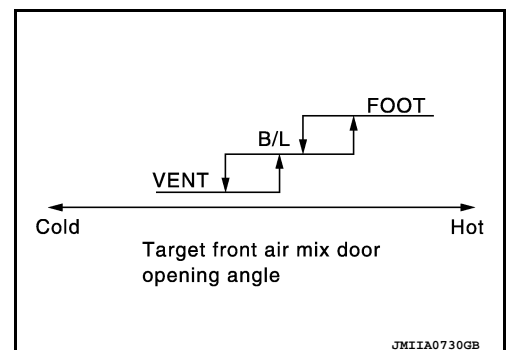

FRONT AUTOMATIC AIR CONDITIONING SYSTEM : Compressor Control

INFOID:000000008901676

DESCRIPTION

- When the compressor activation condition is satisfied while blower motor is activated, A/C auto amp. transmits A/C ON signal and blower fan ON signal to ECM via CAN communication.
- ECM judges that the compressor can be activated depending on each sensors state (refrigerant pressure sensor signal and others) and transmits A/C compressor request signal to IPDM E/R via CAN communication.
- IPDM E/R turns A/C relay ON and activates the compressor depending on request from ECM.

COMPRESSOR PROTECTION CONTROL AT PRESSURE MALFUNCTION

When high-pressure side value that is detected by refrigerant pressure sensor is as per the following state, ECM requests IPDM E/R to turn A/C relay OFF and stops the compressor.

- 3.12 MPa (31.82 kg/cm², 452.4 psi) or more (When the engine speed is less than 1,500 rpm)
- 2.74 MPa (27.95 kg/cm², 397.3 psi) or more (When the engine speed is 1,500 rpm or more)
- 0.14 MPa (1.43 kg/cm², 20.3 psi) or less

COMPRESSOR OIL CIRCULATION CONTROL

When the engine starts while the engine coolant temperature is 56°C (133°F) or less, ECM activates the compressor for approximately 6 seconds and circulates the compressor lubricant once.

LOW TEMPERATURE PROTECTION CONTROL

- When intake sensor detects that front evaporator fin temperature is 2.5°C (37°F) or less, A/C auto amp. requests ECM to turn compressor OFF, and stops the compressor.
- When the front evaporator fin temperature returns to 5.0°C (41°F) or more, the compressor is activated.

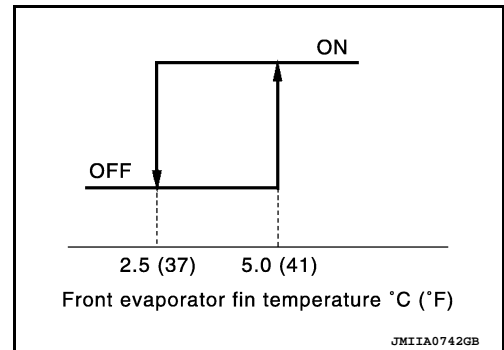

OPERATING RATE CONTROL

When set temperature is other than fully cold or air outlet is "VENT", "B/L" or "FOOT" A/C auto amp. controls the compressor activation depending on ambient temperature.

AIR CONDITIONING CUT CONTROL









When set engine is running is excessively high load condition, ECM requests IPDM E/R to turn A/C relay OFF, and stops the compressor. Refer to [EC-37, "AIR CONDITIONING CUT CONTROL : System Description"](#) for details.









A
B
C
D
E
F
G
H
HAC
J
K
L
M
N
O
P

SYSTEM

< SYSTEM DESCRIPTION >

[AUTOMATIC AIR CONDITIONING]

- | | | |
|---------------------|-------------------------|-------------------------|
| 1. Intake door | 2. Front blower motor | 3. In-cabin microfilter |
| 4. Front evaporator | 5. Air mix door (front) | 6. Front heater core |
| 7. Foot door | 8. Ventilator door | 9. Defroster door |
| 10. Max. cool door | | |
-
- | | | |
|--|---|---|
|  Fresh air |  Recirculation air |  Discharge air |
|  Defroster |  Center ventilator |  Side ventilator |
|  Front foot |  Rear foot | |

Switch position		Door position						
		Mode door (front)				Intake door	Air mix door (front)	
		Ventilator door	Max. cool door	Defroster door	Foot door		(Driver side)	(Passenger side)
AUTO switch		AUTO						
MODE switch		A	A	A	A	—	—	—
		B	B	A	B			
		C	C	B	B			
		C	B	B	B			
DEF switch	 	C	A	C	C	A	—	—
Intake switch*	 	—	—	—	—			
Temperature control switch (Driver side)	DUAL switch: OFF					Full cold [18°C (60°F)]	—	—
		18.5°C – 31.5°C (61°F – 89 °F)	AUTO					
		Full hot [32°C (90°F)]	B					
Temperature control switch (Driver side)	DUAL switch: ON	Full cold [18°C (60°F)]	—	—	—	—	A	—
		18.5°C – 31.5°C (61°F – 89 °F)					AUTO	
		Full hot [32°C (90°F)]					B	
Temperature control switch (Passenger side)		Full cold [18°C (60°F)]	—	—	—	—	—	A
		18.5°C – 31.5°C (61°F – 89 °F)						AUTO
		Full hot [32°C (90°F)]						B
ON-OFF switch	OFF	C	C	B	B	B	—	

*: Inlet status is displayed by indicator during activating automatic control

AIR DISTRIBUTION

A
B
C
D
E
F
G
H
HAC
J
K
L
M
N
O
P

SYSTEM

< SYSTEM DESCRIPTION >

[AUTOMATIC AIR CONDITIONING]

Discharge air flow						
MODE/DEF set position	Condition	Air outlet/distribution				
		Ventilator		Foot		Defroster
		Center	Side	Front	Rear	
	DUAL switch: OFF	50%	50%	—		—
		26%	30%	30%	14%	—
		—	14%	40%	16.5%	29.5%
		—	14%	35%	16%	35%
		—	12%	—		88%

FRONT AUTOMATIC AIR CONDITIONING SYSTEM : Temperature Control

INFOID:000000008901678

- When ignition switch is in the ON position, A/C auto amp. always automatically controls temperature regardless of front air conditioning operational state.
- A/C auto amp. calculates the target air mix door (front) opening angle depending on set temperature, in-vehicle temperature, ambient temperature, and sunload.
- Air mix door (front) is controlled depending on the comparison of current air mix door (front) opening angle and target air mix door (front) opening angle.
- Regardless of in-vehicle temperature, ambient temperature, and sunload, air mix door (front) is fixed at the fully cold position when set temperature is 18.0°C (60°F), and at the fully hot position when set temperature is 32.0°C (90°F).

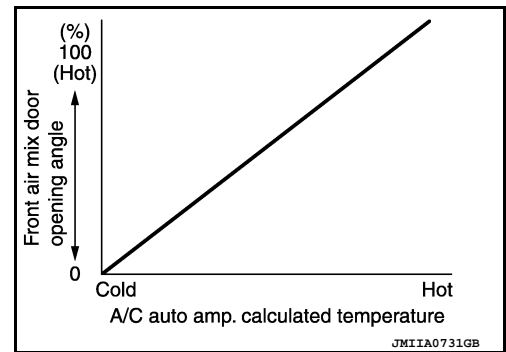

FRONT AUTOMATIC AIR CONDITIONING SYSTEM : Fail-safe

INFOID:000000008901679

FAIL-SAFE FUNCTION

If a communication error exists between the A/C auto amp., and the AV control unit and preset switch for 30 seconds or longer, air conditioning is controlled under the following conditions:

When ambient temperature is less than 3°C (37°F) and engine coolant temperature is less than 56°C (133°F)

- Compressor** : ON
- Air outlet** : DEF
- Air inlet** : FRE (Fresh air intake)
- Blower fan speed** : AUTO
- Set temperature** : Setting before communication error occurs

When ambient temperature is 3°C (37°F) or more, or engine coolant temperature is 56°C (133°F) or more

- Compressor** : ON
- Air outlet** : AUTO
- Air inlet** : 20% FRE (20% fresh air intake)
- Blower fan speed** : AUTO
- Set temperature** : Setting before communication error occurs

REAR AUTOMATIC AIR CONDITIONING SYSTEM

SYSTEM

< SYSTEM DESCRIPTION >

[AUTOMATIC AIR CONDITIONING]

REAR AUTOMATIC AIR CONDITIONING SYSTEM : System Diagram

INFOID:000000008901680

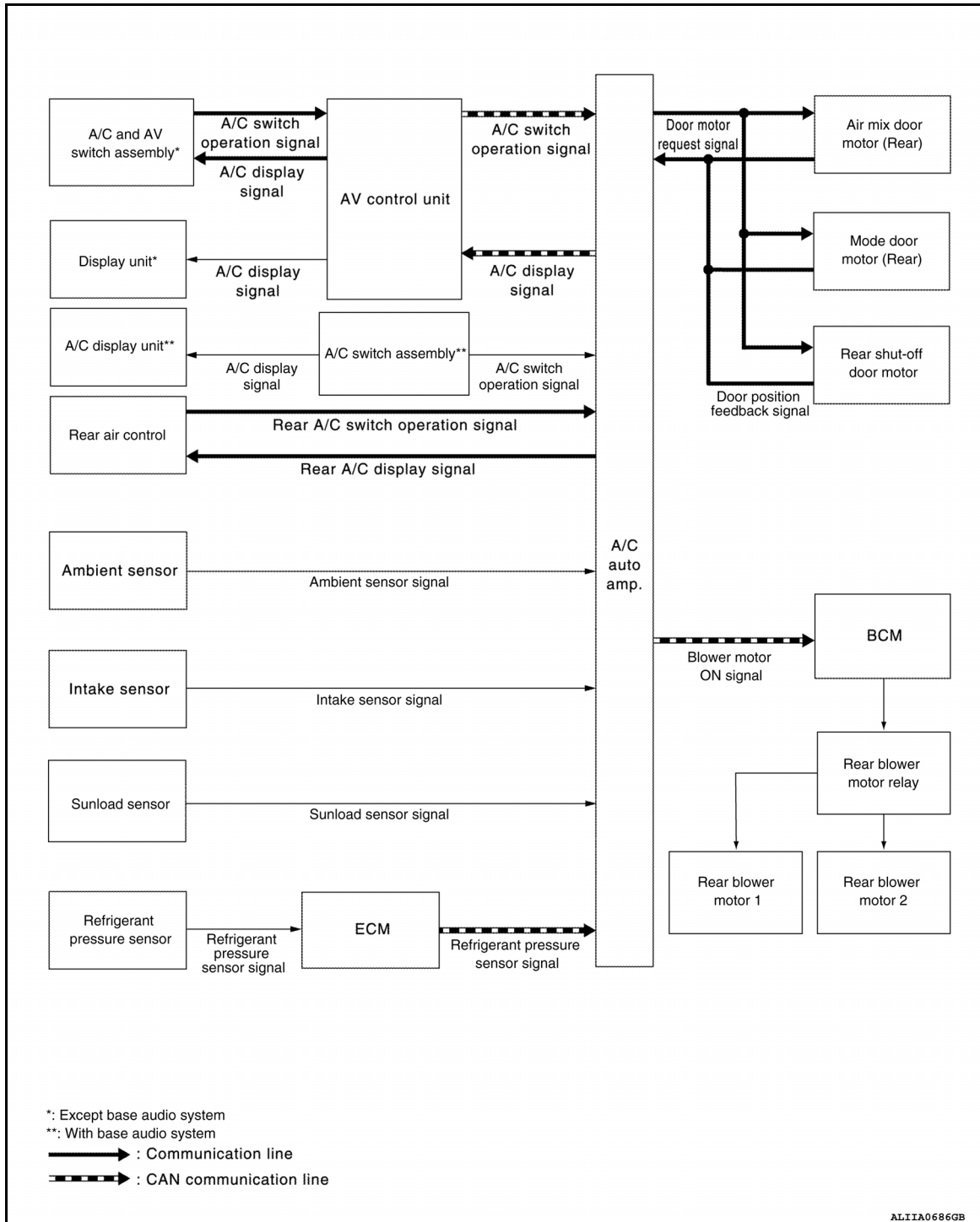

A
B
C
D
E
F
G
H
I
J
K
L
M
N
O
P

HAC

REAR AUTOMATIC AIR CONDITIONING SYSTEM : System Description

INFOID:000000008901681

- Rear automatic air conditioning system is controlled by each function of A/C auto amp.

Control by A/C auto amp.

- [HAC-29. "REAR AUTOMATIC AIR CONDITIONING SYSTEM : Air Flow Control"](#)
- [HAC-30. "REAR AUTOMATIC AIR CONDITIONING SYSTEM : Air Outlet Control"](#)
- [HAC-30. "REAR AUTOMATIC AIR CONDITIONING SYSTEM : Door Control"](#)
- [HAC-31. "REAR AUTOMATIC AIR CONDITIONING SYSTEM : Temperature Control"](#)
- [HAC-28. "REAR AUTOMATIC AIR CONDITIONING SYSTEM : Intelligent Key Interlock Function"](#)
- Correction for input value of each sensor

SYSTEM

< SYSTEM DESCRIPTION >

[AUTOMATIC AIR CONDITIONING]

Ambient sensor (setting temperature correction)

- A/C auto amp. controls passenger room temperature so that the optimum level always matches the temperature level that passenger may feel. Correction is applied to the target temperature that is set using temperature control dial, according to ambient temperature detected by ambient sensor.

Intake sensor (intake temperature correction)

- A/C auto amp. performs correction to change recognition intake temperature of A/C auto amp. quickly when difference is large between recognition intake temperature and intake temperature detected by intake temperature sensor. The correction is performed to change recognition intake temperature slowly when difference is small.

Sunload sensor (sunload amount correction)

- Sunload amount detected by sunload sensor is corrected for each rear automatic air conditioning control.
- A/C auto amp. performs correction to change recognition sunload amount of A/C auto amp. slowly when sunload amount changes quickly, for example when entering or exiting a tunnel.

Operation by front controller (with base audio system)

- Front A/C control (A/C switch assembly) transmits the commands for rear automatic air conditioning system operation to A/C auto amp. via communication line, the A/C auto amp. transmits each indication information to A/C display unit via communication line. A/C display unit displays each indication information that is received.

Operation by front controller (except base audio system)

- Front A/C control (A/C and AV switch assembly) transmits the commands for rear automatic air conditioning system operation to AV control unit via communication line, then AV control unit transmits the commands to A/C auto amp. via CAN communication. A/C auto amp. transmits each indication information to AV control unit via CAN communication. AV control unit displays each indication information that is received.

Operation by rear controller

- Rear air control transmits the commands for rear automatic air conditioning system operation to A/C auto amp. via communication line.

REAR AUTOMATIC AIR CONDITIONING SYSTEM : Intelligent Key Interlock Function

INFOID:000000008901682

DESCRIPTION

- Setting value of rear air conditioning system when ignition switch is previously OFF can be memorized for each Intelligent Key. Rear air conditioning system is automatically operated by the setting value.

NOTE:

- Setting value can be memorized for up to 3 Intelligent Keys.
- Interlock items are as per the following table.

Operation	Conditions
A/C and AV switch assembly / Rear air control	AUTO switch (ON/OFF)
	Setting temperature (Setting value)
	Air flow (Setting value)
	Air outlet (VENT / FOOT)

Operation Description

Memory

1. Unlock door using Intelligent Key or driver door request switch.
2. BCM transmits Key ID signal to A/C auto amp. via CAN communication line.
3. When ignition switch turns OFF, A/C auto amp. memorizes setting information (setting temperature, air outlet status, and others) of rear air conditioning system to memory for each Key ID.

Readout

1. Unlock door using Intelligent Key or driver door request switch.
2. BCM transmits Key ID signal to A/C auto amp. via CAN communication line.
3. When ignition switch turns ON, A/C auto amp. operates automatically rear air conditioning system according to setting information of Key ID that is received.

NOTE:

SYSTEM

< SYSTEM DESCRIPTION >

[AUTOMATIC AIR CONDITIONING]

When Intelligent Key interlock function operates, "Connection with the key has been done." is displayed.

REAR AUTOMATIC AIR CONDITIONING SYSTEM : Air Flow Control

INFOID:000000008901683

DESCRIPTION

- A/C auto amp. changes duty ratio of rear blower motor drive signal and controls air flow continuously. When air flow is increased, duty ratio of rear blower motor control signal gradually increases to prevent a sudden increase in air flow.
- In addition to manual control and automatic control, air flow control is composed of starting fan speed control, low coolant temperature starting control, high in-vehicle temperature starting control and fan speed control at door motor operation

AUTOMATIC AIR FLOW CONTROL

- A/C auto amp. decides target air flow depending on target air mix door (rear) opening angle.
- A/C auto amp. changes duty ratio of rear blower motor control signal and controls the air flow continuously so that air flow matches to target air flow.
- When air outlet is VENT, the minimum air flow is changed depending on sunload.

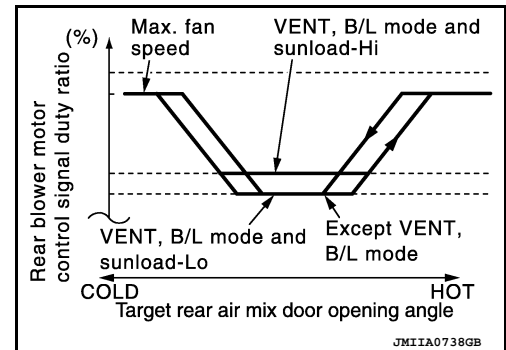

STARTING AIR FLOW CONTROL

- When rear blower motor is activated, A/C auto amp. gradually increases duty ratio of rear blower motor control signal to prevent a sudden increase in discharge air flow.
- It takes approximately 8 seconds for air flow to reach HI from LOW.

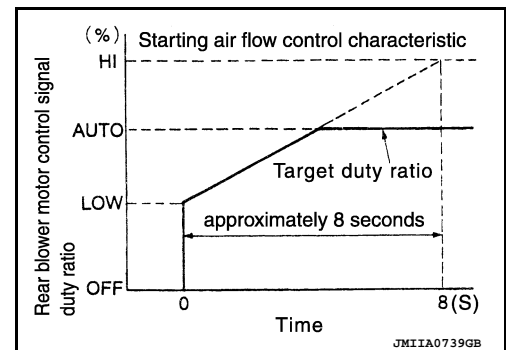

LOW COOLANT TEMPERATURE STARTING CONTROL

If the engine coolant temperature is 56°C (133°F) or less, to prevent a cold discharged air flow, A/C auto amp. suspends rear blower motor activation for the maximum 150 seconds depending on target air mix door (rear) opening angle. After this, rear blower motor control signal is increased gradually, and rear blower motor is activated.

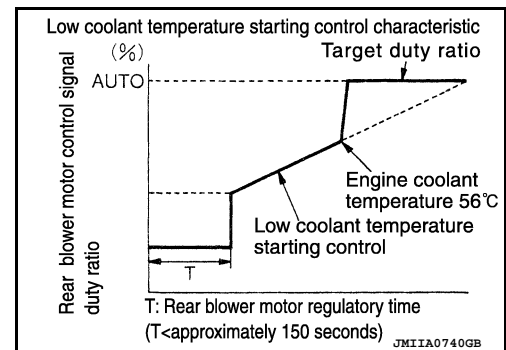

HIGH IN-VEHICLE TEMPERATURE STARTING CONTROL

When front evaporator fin temperature is high [intake sensor value is 35°C (95°F) or more], to prevent a hot discharged air flow, A/C auto amp. suspends rear blower motor activation for approximately 3 seconds so that rear evaporator is cooled by refrigerant.

FAN SPEED CONTROL AT DOOR MOTOR OPERATION

SYSTEM

< SYSTEM DESCRIPTION >

[AUTOMATIC AIR CONDITIONING]

When mode door motor (rear) is activated while air flow is more than the specified value, A/C auto amp. reduces temporarily fan speed so that mode door (rear) moves smoothly.

REAR AUTOMATIC AIR CONDITIONING SYSTEM : Air Outlet Control

INFOID:000000008901684

- While air outlet is in automatic control, A/C auto amp. selects the mode door (rear) position depending on a target air mix door (rear) angle and outlet air temperature calculated from sunload.

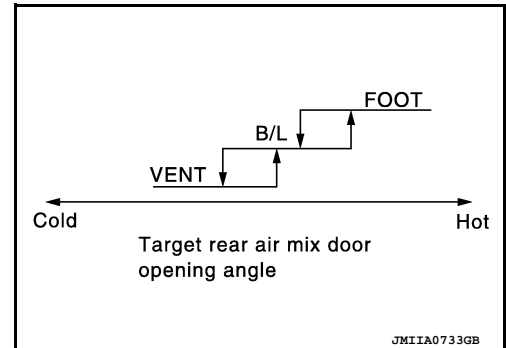

REAR AUTOMATIC AIR CONDITIONING SYSTEM : Door Control

INFOID:000000008901685

DOOR MOTOR CONTROL

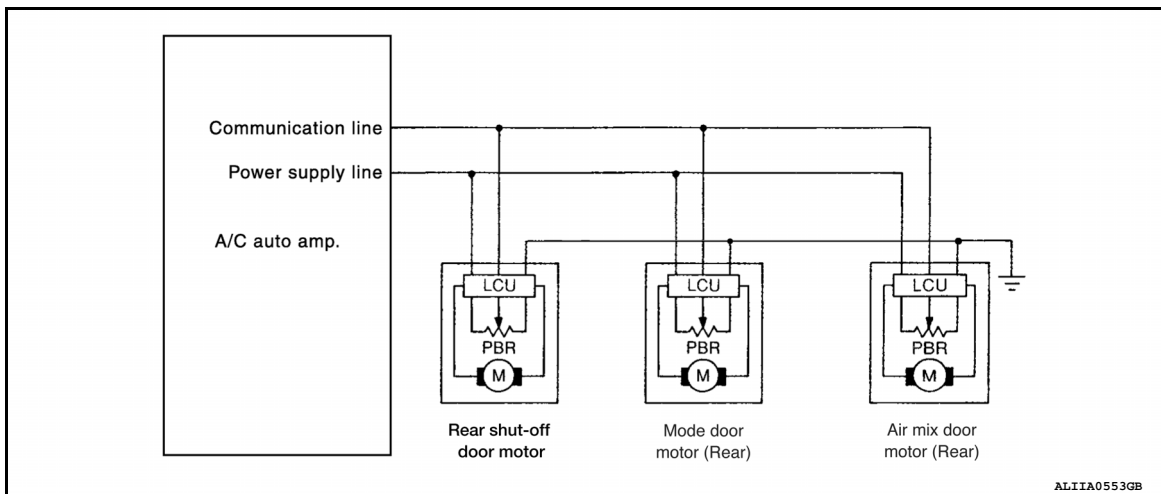

- LCU (Local Control Unit) is built in to each door motor, and detects door position by PBR (Potentiometer Balance Resistor).
- A/C auto amp. communicates with each LCU via communication line and receives each door position feedback signal from each LCU.
- Each LCU controls each door to the appropriate position depending on the control signal from A/C auto amp. when the door movement is complete, transmits the signal of door movement completion to A/C auto amp.

SWITCHES AND THEIR CONTROL FUNCTION

SYSTEM

< SYSTEM DESCRIPTION >

[AUTOMATIC AIR CONDITIONING]

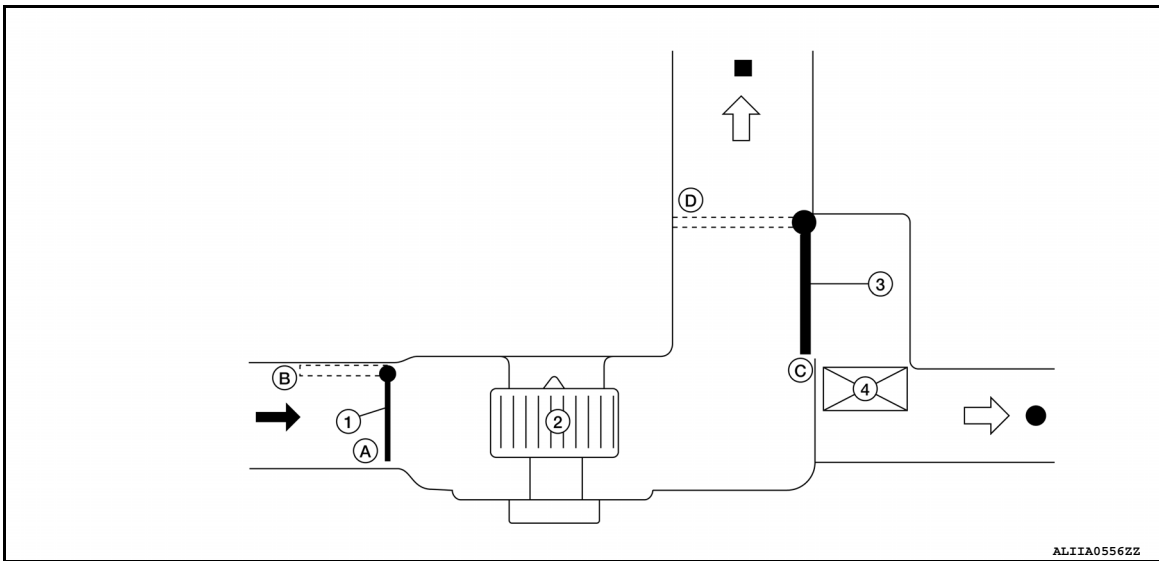

- 1. Rear shut-off door
- 2. Rear blower motor 1
- 3. Mode door (rear)
- 4. PTC heater
- ← Recirculation air
- Rear ventilator
- Rear A/C foot

Switch/Dial position		Door position	
		Mode door (rear)	Rear shut-off door
AUTO switch	Front A/C control	☀	AUTO
	Rear air control	AUTO	
	VENT	↕	—
	FOOT	↙	—
OFF switch		AUTO	A

AIR DISTRIBUTION

Discharge air flow		
Mode position	Air outlet/distribution	
	VENT	FOOT
↕	100%	—
↙	—	100%

REAR AUTOMATIC AIR CONDITIONING SYSTEM : Temperature Control INFOID:000000008901686

- When ignition switch is in the ON position, A/C auto amp. always automatically controls temperature regardless of rear air conditioning operational state.
- A/C auto amp. calculates the target air mix door (rear) opening angle depending on set temperature, ambient temperature, and sunload.
- Air mix door (rear) is controlled depending on the comparison of current air mix door (rear) opening angle and target air mix door (front) opening angle.
- Regardless of ambient temperature, and sunload, air mix door (rear) is fixed at the fully cold position when set temperature is 18.0°C (60°F), and at the fully hot position when set temperature is 32.0°C (90°F).

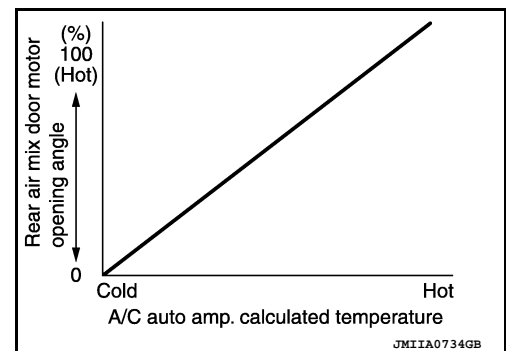

OPERATION

< SYSTEM DESCRIPTION >

[AUTOMATIC AIR CONDITIONING]

OPERATION

FRONT AUTOMATIC AIR CONDITIONING SYSTEM

FRONT AUTOMATIC AIR CONDITIONING SYSTEM : Switch Name and Function

INFOID:000000008901692

FRONT AIR CONTROLLER OPERATION (WITH BASE AUDIO SYSTEM)

A/C Display

Front air conditioning system state is indicated on the display.

Display Screen

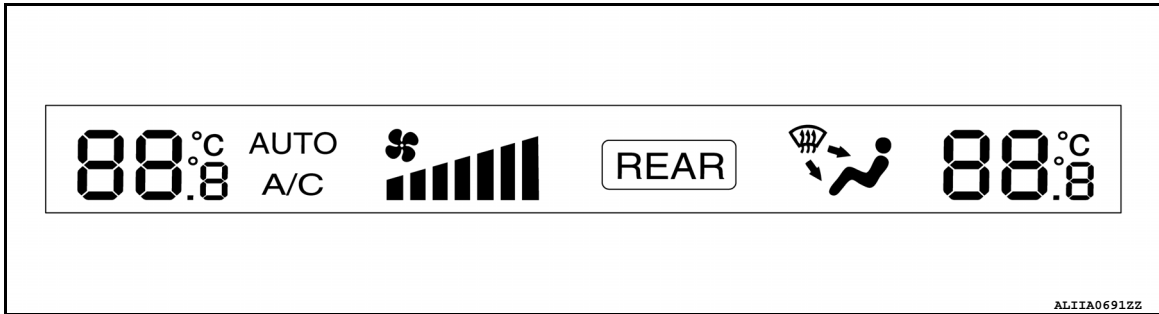

Controller (A/C switch assembly)

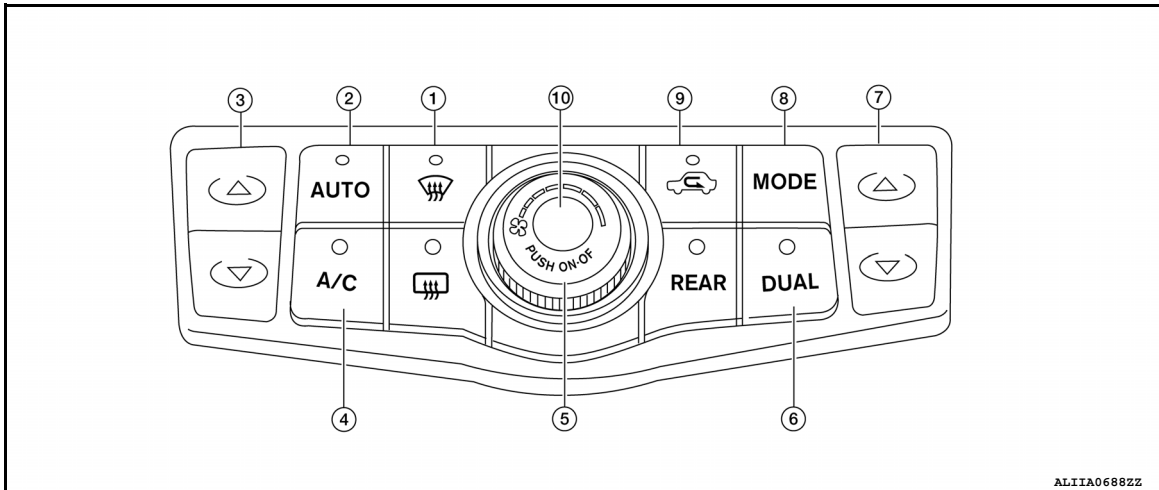

- | | | |
|---|----------------|--------------------------------------|
| 1. DEF switch | 2. AUTO switch | 3. Temperature control (Driver side) |
| 4. A/C switch | 5. Fan switch | 6. DUAL switch |
| 7. Temperature control (passenger side) | 8. MODE switch | 9. Intake switch |
| 10. ON/OFF switch | | |

Switch Operation

A/C switch	<p>Turns the compressor control (switch indicator) between ON ⇔ OFF each time while front blower fan is activated.</p> <p>NOTE:</p> <ul style="list-style-type: none"> • When front blower fan is OFF, the compressor control cannot be activated. • When the compressor control (switch indicator) is in the OFF position, air inlet is fresh air intake.
AUTO switch	<p>Turns the switch indicator lamp and "AUTO" indicator on the display ON, and then front air conditioning system becomes the following state.</p> <ul style="list-style-type: none"> • Air inlet: Automatic control • Air outlet: Automatic control • Blower fan: Automatic control • Compressor: ON

OPERATION

< SYSTEM DESCRIPTION >

[AUTOMATIC AIR CONDITIONING]

Defroster (DEF) switch	<p>Turns DEF mode (switch indicator) between ON ⇔ OFF each time.</p> <p>When DEF switch is pressed while front air conditioning system is in the ON position.</p> <ul style="list-style-type: none"> • When DEF mode is turned ON, front air conditioning system becomes the following state. <ul style="list-style-type: none"> - Air inlet: Fresh air intake - Air outlet: DEF - Blower fan: Automatic control (If fan speed other than AUTO is selected before pressing DEF switch, fan speed is manual control.) - Compressor: ON • When DEF mode is turned OFF, front air conditioning system state returns to the previous state before DEF mode is selected. But, the following state is continued. <ul style="list-style-type: none"> - Air inlet: Fresh air intake - Compressor: ON <p>When DEF switch is pressed while front air conditioning system is in the OFF position.</p> <ul style="list-style-type: none"> • When DEF mode is turned ON, front air conditioning system becomes the following state. <ul style="list-style-type: none"> - Air inlet: Fresh air intake - Air outlet: DEF - Blower fan: Automatic control - Compressor: ON • When DEF mode is turned OFF, entire front air conditioning system is set to auto mode. <p>NOTE: When DEF mode turns ON while front air conditioning system is in automatic control ("AUTO" is indicated), automatic control is released ("AUTO" turns OFF).</p>	A B C D E F
DUAL switch	<ul style="list-style-type: none"> • Turns left and right ventilation temperature separately control (switch indicator) between ON ⇔ OFF each time. • When DUAL switch indicator is ON, the driver side and passenger side temperatures can each be set independently. • When DUAL switch indicator is OFF, the driver side outlet and setting temperature is applied to both sides. • Left and right ventilation temperature separately control is cancelled by turning the DEF mode ON. <p>NOTE: When front air conditioning system is in the OFF position, left and right ventilation temperature separately control can be selected only while front air conditioning system state (when MODE switch is pressed) is indicated on the display.</p>	G H
Fan switch	<p>Blower fan speed is manually controlled with this switch.</p> <p>NOTE:</p> <ul style="list-style-type: none"> • When fan switch is operated while front air conditioning system is in OFF, front air conditioning system is activated. (Compressor control state returns to the previous state before front air conditioning system OFF.) • When fan switch is operated while front air conditioning system is in automatic control ("AUTO" is indicated), automatic control is released ("AUTO" turns OFF). 	J K
MODE switch	<p>Selects air outlet sequentially from VENT ⇒ B/L ⇒ FOOT ⇒ D/F ⇒ VENT each time.</p> <p>NOTE:</p> <ul style="list-style-type: none"> • When front air conditioning system is in the OFF position, air outlet can be selected. • When MODE switch is pressed while front air conditioning system is in automatic control ("AUTO" is indicated), automatic control is released ("AUTO" turns OFF). 	L M
ON/OFF switch	<ul style="list-style-type: none"> • Turns front air conditioning system ON/OFF. • When front air conditioning system turns OFF, air inlet and air outlet become the automatic control. 	
Intake switch	<p>Air inlet changes between recirculation (REC) ⇔ fresh air intake (FRE) each time this switch is pressed.</p> <ul style="list-style-type: none"> • Intake switch indicator ON: Recirculation • Intake switch indicator OFF: Fresh air intake <p>NOTE:</p> <ul style="list-style-type: none"> • When front air conditioning system is in the OFF position, air inlet can be selected. • When MODE switch and DEF switch is in the D/F or DEF position, air inlet cannot be selected to recirculation (REC). 	N O P

HAC

OPERATION

< SYSTEM DESCRIPTION >

[AUTOMATIC AIR CONDITIONING]

<p>Temperature control switch (Driver side)</p>	<p>Setting temperature is selected using this switch within a range between 18°C (60°F) and 32°C (90°F) at a rate of 0.5°C (1.0°F) per adjustment.</p> <ul style="list-style-type: none"> ▲ Press: Setting temperature increases ▼ Press: Setting temperature decreases <p>NOTE: When air conditioning system is OFF, setting temperature can be selected only while air conditioning system status screen [only when MODE switch (driver side) is pressed] is indicated on display.</p>
<p>Temperature control switch (Passenger side)</p>	<ul style="list-style-type: none"> The system is set to LH/RH independent status ("DUAL" displays) by operating this switch. Outlet air flow temperature of passenger side can be changed without changing outlet air flow temperature of driver side. Setting temperature is selected using this switch within a range between 18°C (60°F) and 32°C (90°F) at a rate of 0.5°C (1.0°F) per adjustment. ▲ Press: Setting temperature increases ▼ Press: Setting temperature decreases <p>NOTE:</p> <ul style="list-style-type: none"> When air conditioning system is OFF, setting temperature can be selected only while air conditioning system status screen [only when MODE switch (passenger side) is pressed] is indicated on display. When DEF mode is ON, temperature control switch (passenger side) is inoperative.

FRONT AIR CONTROLLER OPERATION (EXCEPT BASE AUDIO SYSTEM)

A/C Display

- Front air conditioning system state is indicated on the display.
- When "STATUS" on the A/C and AV switch assembly is pressed while front air conditioning system is in the ON position, the display changes to state indication display of front air conditioning system. When front air conditioning system is operated while navigation system or audio system is displayed, front air conditioning system state is indicated in the lower portion of display for several seconds.
- When MODE switch is pressed while front air conditioning system is in the OFF position, state indication display is indicated for several seconds.

Display Screen

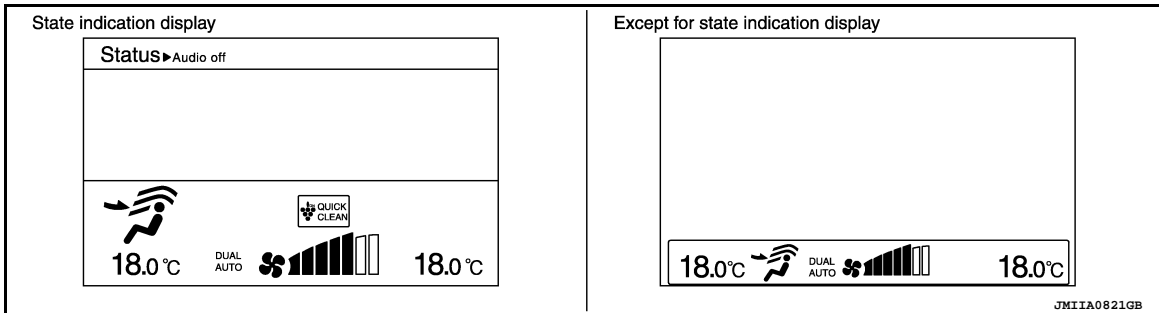

Controller (A/C and AV switch assembly)

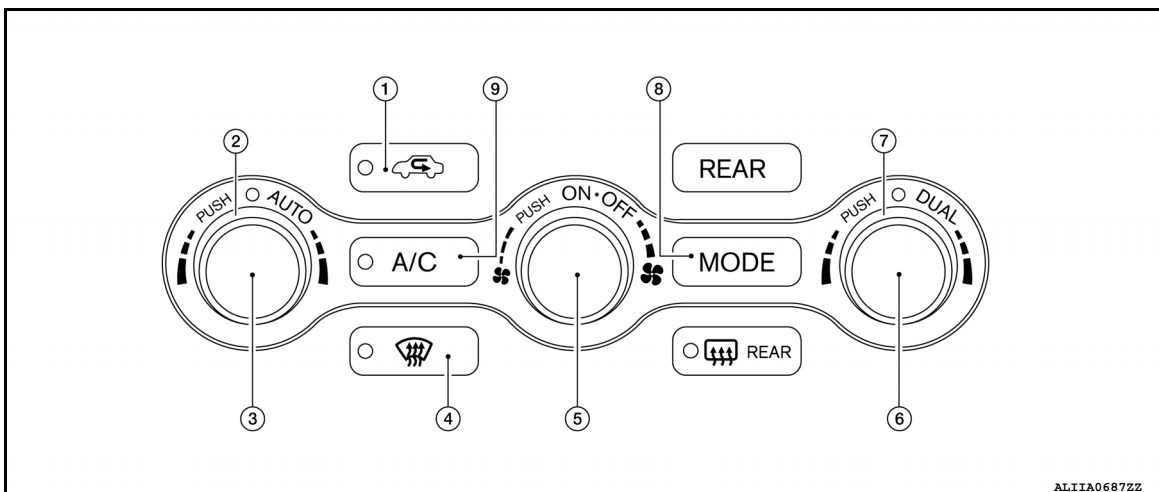

OPERATION

< SYSTEM DESCRIPTION >

[AUTOMATIC AIR CONDITIONING]

- | | | | |
|--|--------------------------------------|----------------|---|
| 1. Intake switch | 2. Temperature control (Driver side) | 3. AUTO switch | |
| 4. DEF switch | 5. ON/OFF switch | 6. DUAL switch | A |
| 7. Temperature control dial (passenger side) | 8. MODE switch | 9. Fan switch | B |
| 10. A/C switch | | | C |

Switch Operation

A/C switch	<p>Turns the compressor control (switch indicator) between ON ⇔ OFF each time while front blower fan is activated.</p> <p>NOTE:</p> <ul style="list-style-type: none"> • When front blower fan is OFF, the compressor control cannot be activated. • When the compressor control (switch indicator) is in the OFF position, air inlet is fresh air intake. 	D
AUTO switch	<p>Turns the switch indicator lamp and "AUTO" indicator on the display ON, and then front air conditioning system becomes the following state.</p> <ul style="list-style-type: none"> • Air inlet: Automatic control • Air outlet: Automatic control • Blower fan: Automatic control • Compressor: ON 	E
Defroster (DEF) switch	<p>Turns DEF mode (switch indicator) between ON ⇔ OFF each time.</p> <p>When DEF switch is pressed while front air conditioning system is in the ON position.</p> <ul style="list-style-type: none"> • When DEF mode is turned ON, front air conditioning system becomes the following state. <ul style="list-style-type: none"> - Air inlet: Fresh air intake - Air outlet: DEF - Blower fan: Automatic control (If fan speed other than AUTO is selected before pressing DEF switch, fan speed is manual control.) - Compressor: ON • When DEF mode is turned OFF, front air conditioning system state returns to the previous state before DEF mode is selected. But, the following state is continued. <ul style="list-style-type: none"> - Air inlet: Fresh air intake - Compressor: ON When DEF switch is pressed while front air conditioning system is in the OFF position. • When DEF mode is turned ON, front air conditioning system becomes the following state. <ul style="list-style-type: none"> - Air inlet: Fresh air intake - Air outlet: DEF - Blower fan: Automatic control - Compressor: ON • When DEF mode is turned OFF, entire front air conditioning system is set to auto mode. <p>NOTE:</p> <p>When DEF mode turns ON while front air conditioning system is in automatic control ("AUTO" is indicated), automatic control is released ("AUTO" turns OFF).</p>	G
DUAL switch	<ul style="list-style-type: none"> • Turns left and right ventilation temperature separately control (switch indicator) between ON ⇔ OFF each time. • When DUAL switch indicator is ON, the driver side and passenger side temperatures can each be set independently. • When DUAL switch indicator is OFF, the driver side outlet and setting temperature is applied to both sides. • Left and right ventilation temperature separately control is cancelled by turning the DEF mode ON. <p>NOTE:</p> <p>When front air conditioning system is in the OFF position, left and right ventilation temperature separately control can be selected only while front air conditioning system state (when MODE switch is pressed) is indicated on the display.</p>	H
Fan switch	<p>Blower fan speed is manually controlled with this switch.</p> <p>NOTE:</p> <ul style="list-style-type: none"> • When fan switch is operated while front air conditioning system is in OFF, front air conditioning system is activated. (Compressor control state returns to the previous state before front air conditioning system OFF.) • When fan switch is operated while front air conditioning system is in automatic control ("AUTO" is indicated), automatic control is released ("AUTO" turns OFF). 	I

HAC

OPERATION

< SYSTEM DESCRIPTION >

[AUTOMATIC AIR CONDITIONING]

MODE switch	<p>Selects air outlet sequentially from VENT ⇒ B/L ⇒ FOOT ⇒ D/F ⇒ VENT each time.</p> <p>NOTE:</p> <ul style="list-style-type: none"> • When front air conditioning system is in the OFF position, air outlet can be selected. • When MODE switch is pressed while front air conditioning system is in automatic control ("AUTO" is indicated), automatic control is released ("AUTO" turns OFF).
ON/OFF switch	<ul style="list-style-type: none"> • Turns front air conditioning system ON/OFF. • When front air conditioning system turns OFF, air inlet and air outlet become the automatic control.
Intake switch	<p>Air inlet changes between recirculation (REC) ⇔ fresh air intake (FRE) each time this switch is pressed.</p> <ul style="list-style-type: none"> • Intake switch indicator ON: Recirculation • Intake switch indicator OFF: Fresh air intake <p>NOTE:</p> <ul style="list-style-type: none"> • When front air conditioning system is in the OFF position, air inlet can be selected. • When MODE switch and DEF switch is in the D/F or DEF position, air inlet cannot be selected to recirculation (REC).
Temperature control switch (Driver side)	<ul style="list-style-type: none"> • Selects set temperature within a range between 18.0°C (60°F) – 32.0°C (90°F) at a rate of 0.5°C (1°F) each time the dial is rotated. - Clockwise rotation: Set temperature increases. - Counterclockwise rotation: Set temperature decreases. <p>NOTE:</p> <p>When front air conditioning system is in the OFF position, set temperature can be selected only while front air conditioning system state (when MODE switch is pressed) is indicated on the display.</p>
Temperature control switch (Passenger side)	<ul style="list-style-type: none"> • Selects set temperature within a range between 18.0°C (60°F) – 32.0°C (90°F) at a rate of 0.5°C (1°F) each time the dial is rotated. - Clockwise rotation: Set temperature increases. - Counterclockwise rotation: Set temperature decreases. • When the temperature control dial is turned, DUAL switch indicator turns ON. <p>NOTE:</p> <p>When front air conditioning system is in the OFF position, set temperature can be selected only while front air conditioning system state (when MODE switch is pressed) is indicated on the display.</p>

REAR AUTOMATIC AIR CONDITIONING SYSTEM

REAR AUTOMATIC AIR CONDITIONING SYSTEM : Switch Name and Function

INFOID:000000008901693

FRONT CONTROLLER OPERATION (WITH BASE AUDIO SYSTEM)

A/C Display

- Rear air conditioning system state is indicated on the display unit.
- When REAR switch is pressed while air conditioning system is in the ON position, the display unit changes to state indication display (rear control mode) of rear air conditioning system.

Display screen



Controller (A/C switch assembly)

OPERATION

< SYSTEM DESCRIPTION >

[AUTOMATIC AIR CONDITIONING]

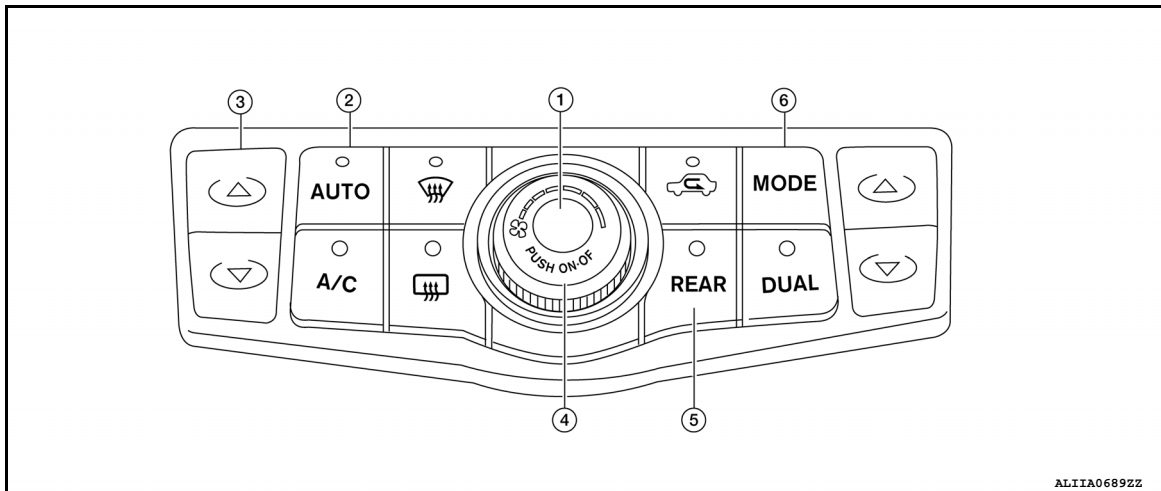

- | | | |
|----------------|--------------------------------------|----------------|
| 1. OFF switch | 2. Temperature control (Driver side) | 3. MODE switch |
| 4. REAR switch | 5. AUTO switch | 6. Fan switch |

Switch Operation

<p>AUTO switch</p>	<p>Turns the switch indicator lamp and "AUTO" indicator on the display unit ON, and then rear air conditioning system becomes the following state.</p> <ul style="list-style-type: none"> • Air outlet: Automatic control • Blower fan: Automatic control • Compressor: ON
<p>Fan switch</p>	<p>Blower fan speed is manually controlled with this switch.</p> <p>NOTE: When fan switch is operated while air conditioning system is in automatic control ("AUTO" is indicated), automatic control is released ("AUTO" turns OFF).</p>
<p>MODE switch</p>	<p>Selects air outlet sequentially from VENT ⇒ B/L ⇒ FOOT ⇒ VENT each time.</p> <p>NOTE: When MODE switch is pressed while air conditioning system is in automatic control ("AUTO" is indicated), automatic control is released ("AUTO" turns OFF).</p>
<p>ON/OFF switch</p>	<ul style="list-style-type: none"> • Turns rear air conditioning system ON/OFF. (When rear control mode is ON) • When rear air conditioning system turns OFF, air outlet become the automatic control.
<p>REAR switch</p>	<ul style="list-style-type: none"> • Turns the switch indicator lamp and rear control mode on the display unit ON, and then rear air conditioning system becomes the following state. <ul style="list-style-type: none"> - Air outlet: Automatic control - Blower fan: Automatic control - Compressor: ON • Rear control mode is released when switch is pressed again (rear air conditioning system operates continuously).
<p>Temperature control switch (Driver side)</p>	<p>Setting temperature is selected using this switch within a range between 18°C (60°F) and 32°C (90°F) at a rate of 0.5°C (1.0°F) per adjustment.</p> <ul style="list-style-type: none"> • ▲ Press: Setting temperature increases • ▼ Press: Setting temperature decreases <p>NOTE: When air conditioning system is OFF, setting temperature can be selected only while air conditioning system status screen [only when MODE switch (driver side) is pressed] is indicated on display.</p>

FRONT CONTROLLER OPERATION (EXCEPT BASE AUDIO SYSTEM)

A/C Display

- Rear air conditioning system state is indicated on the display unit.
- When REAR switch is pressed while air conditioning system is in the ON position, the display unit changes to state indication display (rear control mode) of rear air conditioning system.

OPERATION

< SYSTEM DESCRIPTION >

[AUTOMATIC AIR CONDITIONING]

Display screen

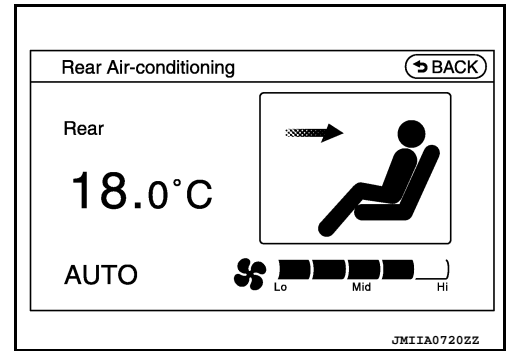

Controller (A/C and AV switch assembly)

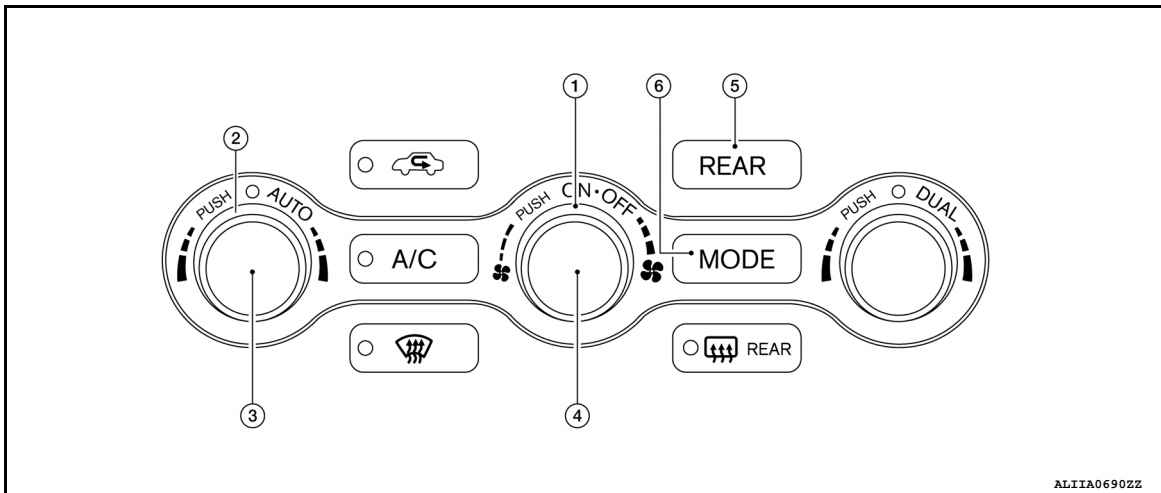

- | | | |
|----------------|--------------------------------------|----------------|
| 1. OFF switch | 2. Temperature control (Driver side) | 3. MODE switch |
| 4. REAR switch | 5. AUTO switch | 6. Fan switch |

Switch Operation

AUTO switch	<p>Turns the switch indicator lamp and "AUTO" indicator on the display unit ON, and then rear air conditioning system becomes the following state.</p> <ul style="list-style-type: none"> • Air outlet: Automatic control • Blower fan: Automatic control • Compressor: ON
Fan switch	<p>Blower fan speed is manually controlled with this switch.</p> <p>NOTE: When fan switch is operated while air conditioning system is in automatic control ("AUTO" is indicated), automatic control is released ("AUTO" turns OFF).</p>
MODE switch	<p>Selects air outlet sequentially from VENT ⇒ B/L ⇒ FOOT ⇒ VENT each time.</p> <p>NOTE: When MODE switch is pressed while air conditioning system is in automatic control ("AUTO" is indicated), automatic control is released ("AUTO" turns OFF).</p>
ON/OFF switch	<ul style="list-style-type: none"> • Turns rear air conditioning system ON/OFF. (When rear control mode is ON) • When rear air conditioning system turns OFF, air outlet become the automatic control.

OPERATION

< SYSTEM DESCRIPTION >

[AUTOMATIC AIR CONDITIONING]

<p>REAR switch</p>	<ul style="list-style-type: none"> • Turns the switch indicator lamp and rear control mode on the display unit ON, and then rear air conditioning system becomes the following state. <ul style="list-style-type: none"> - Air outlet: Automatic control - Blower fan: Automatic control - Compressor: ON • Rear control mode is released when switch is pressed again (rear air conditioning system operates continuously).
<p>Temperature control switch (Driver side)</p>	<ul style="list-style-type: none"> • Selects set temperature within a range between 18.0°C (60°F) – 32.0°C (90°F) at a rate of 0.5°C (1°F) each time the dial is rotated. <ul style="list-style-type: none"> - Clockwise rotation: Set temperature increases. - Counterclockwise rotation: Set temperature decreases. <p>NOTE: When front air conditioning system is in the OFF position, set temperature can be selected only while front air conditioning system state (when MODE switch is pressed) is indicated on the display.</p>

REAR CONTROLLER OPERATION

Controller (Rear Air Control)

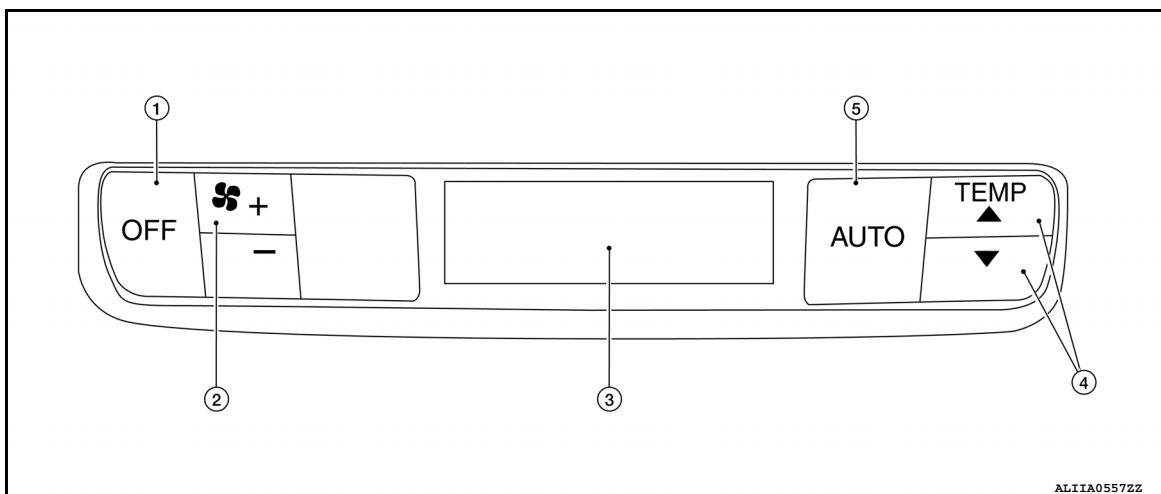

- | | | |
|-------------------------------|----------------|------------|
| 1. OFF switch | 2. Fan switch | 3. Display |
| 4. Temperature control switch | 5. AUTO switch | |

Switch Operation

<p>AUTO switch</p>	<p>Turns the switch indicator lamp and "AUTO" indicator on the display ON, and then rear air conditioning system becomes the following state.</p> <ul style="list-style-type: none"> • Air outlet: Automatic control • Blower fan: Automatic control • Compressor: ON
<p>Fan switch (UP/DOWN)</p>	<p>Blower fan speed is manually controlled with these switches. Seven speeds are available for manual control (as shown on the display screen).</p> <p>NOTE: When fan switch is pressed while air conditioning system is in automatic control ("AUTO" is indicated), automatic control is released ("AUTO" turns OFF).</p>
<p>OFF switch</p>	<ul style="list-style-type: none"> • Turns rear air conditioning system OFF. • When rear air conditioning system turns OFF, air outlet become the automatic control.
<p>Temperature control switch</p>	<p>Setting temperature is selected using this switch with in a range between 18.0°C (60°F) – 32.0°C (90°F) at a rate of 0.5°C (1°F) per adjustment.</p> <ul style="list-style-type: none"> • ▲: Press: Set temperature increases. • ▼: Press: Set temperature decreases.

DIAGNOSIS SYSTEM (HVAC)

< SYSTEM DESCRIPTION >

[AUTOMATIC AIR CONDITIONING]

DIAGNOSIS SYSTEM (HVAC)

Description

INFOID:000000008901695

Air conditioning system performs self-diagnosis, operation check, function diagnosis, and various settings using diagnosis function of each control unit.

ECU	Diagnostic item (CONSULT)	
A/C auto amp.	HVAC	Self Diagnostic Result
		Data Monitor
		Active Test
		Work support
AV control unit	MULTI AV	Self Diagnostic Result
	Multi AV system on board diagnosis function	
ECM	ENGINE	Self Diagnostic Result
		Data Monitor
IPDM E/R	IPDM E/R	Self Diagnostic Result
		Data Monitor
	Auto active test	

CONSULT Function

INFOID:000000008901696

CONSULT performs the following functions via CAN communication with A/C auto amp.

APPLICATION ITEMS

Diagnostic mode	Description
Self Diagnostic Result	Displays the diagnosis results judged by A/C auto amp.
Data Monitor	Displays the input/output signal of A/C auto amp.
Active Test	The signals used to activate each device are forcibly supplied from A/C auto amp.
Work support	Changes the setting for each setting function.
ECU identification	Displays the part number of A/C auto amp.

NOTE:

Diagnosis should be performed with engine running. Door motor operation speeds become slower and NO results may be returned even for normal operation if battery voltage drops below 12 V during self-diagnosis.

SELF-DIAGNOSIS RESULTS

Refer to [HAC-47, "DTC Index"](#).

ACTIVE TEST

Test item	Description
HVAC TEST	The operation check of air conditioning system can be performed by selecting the mode. Refer to the following table for the conditions of each mode.

Check each output device

	Test item						
	MODE 1	MODE 2	MODE 3	MODE 4	MODE 5	MODE 6	MODE 7
Mode door motor (front) position	VENT	VENT	B/L	D/F	D/F	DEF	DEF
Intake door motor position	REC	REC	20% FRE	FRE	FRE	FRE	FRE

DIAGNOSIS SYSTEM (HVAC)

[AUTOMATIC AIR CONDITIONING]

< SYSTEM DESCRIPTION >

	Test item						
	MODE 1	MODE 2	MODE 3	MODE 4	MODE 5	MODE 6	MODE 7
Air mix door motor (driver side) position	FULL COLD	FULL COLD	FULL COLD	FULL HOT	FULL HOT	FULL HOT	FULL HOT
Air mix door motor (passenger side) position	FULL COLD	FULL COLD	FULL COLD	FULL HOT	FULL HOT	FULL HOT	FULL HOT
Front blower motor control signal duty ratio	30%	30%	60%	HI	HI	60%	HI
Magnet clutch	ON	ON	ON	OFF	OFF	ON	ON
Mode door motor (rear) position	VENT	VENT	FOOT	FOOT	FOOT	FOOT	FOOT
Air mix door motor (rear) position	FULL COLD	FULL COLD	FULL COLD	FULL HOT	FULL HOT	FULL HOT	FULL HOT
Rear shut-off door motor position	FR / INT CLOSE	FR / INT CLOSE	FR / INT CLOSE	FR / INT CLOSE	FR / INT OPEN	FR / INT OPEN	FR / INT OPEN
PTC heater 1	OFF	ON	ON	ON	ON	OFF	ON
PTC heater 2	OFF	OFF	OFF	ON	ON	OFF	ON
Rear blower motor 1 control signal	3V	3V	7V	HI	HI	7V	3V
Rear blower motor 2 control signal	3V	3V	7V	HI	HI	7V	3V

NOTE:

Perform the inspection of each output device after starting the engine because the compressor is operated.

DATA MONITOR

Display item list

Monitor item [Unit]	Description
AMB TEMP SEN [°C (°F)]	Ambient sensor value converted from ambient sensor signal received from ambient sensor.
IN-VEH TEMP [°C (°F)]	In-vehicle sensor value converted from in-vehicle sensor signal received from in-vehicle sensor.
INT TEMP SEN [°C (°F)]	Intake sensor value converted from intake sensor signal received from intake sensor.
SUNLOAD SEN [w/m ²]	Sunload sensor value converted from sunload sensor signal received from sunload sensor.
AMB SEN CAL [°C (°F)]	Ambient temperature value calculated by A/C auto amp.
IN-VEH CAL [°C (°F)]	In-vehicle temperature value calculated by A/C auto amp.
INT TEMP CAL [°C (°F)]	Front evaporator fin temperature value calculated by A/C auto amp.
SUNL SEN CAL [w/m ²]	Sunload value calculated by A/C auto amp.
COMP REQ SIG [On/Off]	Displays A/C switch ON/OFF status transmitted to other units via CAN communication.
FAN REQ SIG [On/Off]	Displays front blower motor ON/OFF status transmitted to other units via CAN communication.
FAN DUTY	Duty ratio of front blower motor judged by A/C auto amp.
XM	Target discharge front air temperature (driver side) judged by A/C auto amp. depending on the temperature setting and the value from each sensor.
RR XM	Target discharge rear air temperature judged by A/C auto amp. depending on the temperature setting and the value from each sensor.
PA TARGET A/TEMP	Target discharge front air temperature (passenger side) judged by A/C auto amp. depending on the temperature setting and the value from each sensor.
RRFAN REQ SIG [On/Off]	Displays rear blower motor ON/OFF status transmitted to other units via CAN communication.
RR FAN DUTY	Duty ratio of rear blower motor judged by A/C auto amp.

DIAGNOSIS SYSTEM (HVAC)

[AUTOMATIC AIR CONDITIONING]

< SYSTEM DESCRIPTION >

Monitor item [Unit]	Description
ENG COOL TEMP [°C (°F)]	Engine coolant temperature signal value received from ECM via CAN communication.
VEHICLE SPEED [km/h (mph)]	Vehicle speed signal value received from combination meter via CAN communication.
TRI ZONE XM	Target discharge tri zone air temperature judged by A/C auto amp. depending on the temperature setting and the value from each sensor.
BOOSTR FAN RQST SIGNAL [On/Off]	Displays rear blower motor ON/OFF status transmitted to other units via CAN communication.
BOOSTER FAN DUTY	Duty ratio of rear blower motor judged by A/C auto amp.

WORK SUPPORT

Work item	Description	Refer to
REAR TEMP SET CORRECT	Setting change of temperature setting trimmer (rear) can be performed.	HAC-79, "FRONT AUTOMATIC AIR CONDITIONING SYSTEM : Temperature Setting Trimmer (Front)"
TEMP SET CORRECT	Setting change of temperature setting trimmer (front) can be performed.	HAC-79, "FRONT AUTOMATIC AIR CONDITIONING SYSTEM : Temperature Setting Trimmer (Front)"
REC MEMORY SET	Setting change of inlet port memory function (REC) can be performed.	HAC-80, "FRONT AUTOMATIC AIR CONDITIONING SYSTEM : Inlet Port Memory Function (REC)"
FRE MEMORY SET	Setting change of inlet port memory function (FRE) can be performed.	HAC-80, "FRONT AUTOMATIC AIR CONDITIONING SYSTEM : Inlet Port Memory Function (FRE)"
BLOW SET	Setting change of foot position setting trimmer can be performed.	HAC-79, "FRONT AUTOMATIC AIR CONDITIONING SYSTEM : Foot Position Setting Trimmer"

NOTE:

When the battery cable is disconnected from the negative terminal or when the battery voltage becomes 10 V or less, the setting of WORK SUPPORT may be cancelled.

A/C AUTO AMP.

< ECU DIAGNOSIS INFORMATION >

[AUTOMATIC AIR CONDITIONING]

ECU DIAGNOSIS INFORMATION

A/C AUTO AMP.

Reference Value

INFOID:0000000008901697

VALUES ON THE DIAGNOSIS TOOL

Monitor item	Condition		Value/Status
AMB TEMP SEN	Ignition switch ON	—	Equivalent to ambient temperature
IN-VEH TEMP	Ignition switch ON	—	Equivalent to in-vehicle temperature (front side)
INT TEMP SEN	Ignition switch ON	—	Equivalent to front evaporator fin temperature
SUNLOAD SEN	Ignition switch ON	—	Equivalent to sunload (driver side)
AMB SEN CAL	Ignition switch ON	—	Equivalent to ambient temperature
IN-VEH CAL	Ignition switch ON	—	Equivalent to in-vehicle temperature (front side)
INT TEMP CAL	Ignition switch ON	—	Equivalent to front evaporator fin temperature
SUNL SEN CAL	Ignition switch ON	—	Equivalent to sunload (driver side)
COMP REQ SIG	Engine: Run at idle after warming up	A/C switch: ON (Compressor operation status)	On
		A/C switch: OFF	Off
FAN REQ SIG	Engine: Run at idle after warming up	Front blower motor: ON	On
		Front blower motor: OFF	Off
FAN DUTY	Engine: Run at idle after warming up	Front blower motor: ON	25 – 81
		Front blower motor: OFF	0
XM	Ignition switch ON	—	Value according to target air flow temperature (driver side)
RR XM	Ignition switch ON	—	Value according to target air flow temperature (rear side)
PA TARGET A/TEMP	Ignition switch ON	—	Value according to target air flow temperature (passenger side)
RRFAN REQ SIG	Engine: Run at idle after warming up	Rear blower motor: ON	On
		Rear blower motor: OFF	Off
RR FAN DUTY	Engine: Run at idle after warming up	Rear blower motor: ON	25 – 81
		Rear blower motor: OFF	0
ENG COOL TEMP	Ignition switch ON	—	Equivalent to engine coolant temperature
VEHICLE SPEED	Driving	—	Equivalent to speedometer reading
TRI_ZONE XM	Ignition switch ON	—	Value according to target air flow temperature (rear side)
BOOSTR FAN RQST SIGNAL	Engine: Run at idle after warming up	Rear blower motor: ON	On
		Rear blower motor: OFF	Off

A/C AUTO AMP.

< ECU DIAGNOSIS INFORMATION >

[AUTOMATIC AIR CONDITIONING]

Monitor item	Condition		Value/Status
BOOSTER FAN DUTY	Engine: Run at idle after warming up	Rear blower motor: ON	25 – 81
		Rear blower motor: OFF	0

TERMINAL LAYOUT

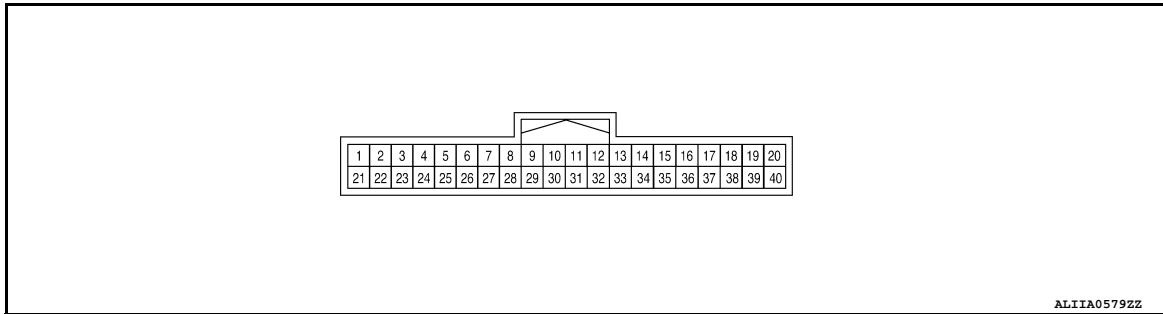

PHYSICAL VALUES

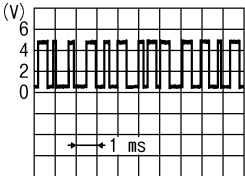
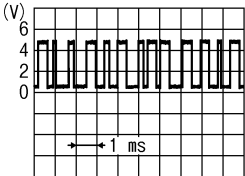
Terminal No. (Wire color)		Description		Condition	Value (Approx.)
+	-	Signal name	Input/ Output		
1 (L)	—	CAN-H	Input/ Output	—	—
2 (GR)	—	Ground	—	—	—
3 (G)	Ground	Battery power supply	Input	Ignition switch OFF	Battery voltage
4 (W)	Ground	Communication signal (A/C auto amp.→A/C switch assembly)	Output	Ignition switch ON	 <small>SJIA1521J</small>
5 (G)	Ground	Communication signal (A/C auto amp.→Rear air control)	Output	Ignition switch ON	 <small>SJIA1521J</small>
7 (G)	Ground	Ambient sensor signal	Input	Ignition switch ON	0 – 4.8 V Output voltage varies with ambient temperature
8*1 (G)	Ground	Heated steering wheel switch signal	Input	Ignition switch ON	<div style="display: flex; justify-content: space-between;"> <div style="width: 45%;">Heated steering wheel switch: While pressing</div> <div style="width: 45%; text-align: center;">0 V</div> </div> <hr/> <div style="display: flex; justify-content: space-between;"> <div style="width: 45%;">Other than the above</div> <div style="width: 45%; text-align: center;">12 V</div> </div>
9 (W)	Ground	Sunload sensor signal	Input	Ignition switch ON	0 – 4.8 V Output voltage varies with sunload amount

A/C AUTO AMP.

< ECU DIAGNOSIS INFORMATION >

[AUTOMATIC AIR CONDITIONING]

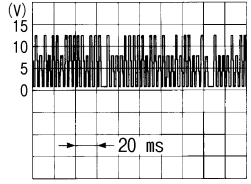
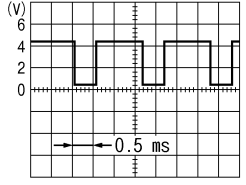
Terminal No. (Wire color)		Description		Condition	Value (Approx.)	
+	-	Signal name	Input/ Output			
12 (G)	Ground	Fan control amp. control signal	Output	• Ignition switch ON • Blower speed: OFF	0 V	
				• Ignition switch ON • Blower speed: 1st - 23rd	2.5 - 3.5 V	
				• Ignition switch ON • Blower speed: 24th - 25th	10 V	
13 (W)	Ground	IGN 2	Input	Ignition switch ON	Battery voltage	
14 (W)	Ground	Fan control amp. control signal	Output	• Ignition switch ON • Blower speed: OFF	0 V	
				• Ignition switch ON • Blower speed: 1st - 23rd	2.5 - 3.5 V	
				• Ignition switch ON • Blower speed: 24th - 25th	10 V	
16 (Y)	Ground	Each door motor LIN signal	Input/ Output	Ignition switch ON	 <small>SJIA1453J</small>	
17 (LG)	Ground	Each door motor power supply	Output	Ignition switch ON	12 V	
18 (W)	Ground	Front blower motor control signal	Output	• Ignition switch ON • Front fan speed: 1st speed (manual)	 <small>JSIIA0096ZZ</small>	
19 (W)	Ground	PTC1 relay output signal	Input	Ignition switch ON	PTC heater: ON	0 V
				PTC heater: OFF	12 V	
20*1 (BR)	Ground	Heated steering wheel relay control signal	Output	Ignition switch ON	Within 30 seconds after turning ON the heated steering switch.	0 V
					Other than the above	12 V
21 (P)	—	CAN-L	Input/ Output	—	—	
22 (GR)	—	Ground	—	—	—	
23 (LG)	Ground	Ignition power supply	Input	Ignition switch ON	Battery voltage	

A

B

C

D

E

F

G

H

HAC

J

K

L

M

N

O

P

A/C AUTO AMP.

< ECU DIAGNOSIS INFORMATION >

[AUTOMATIC AIR CONDITIONING]

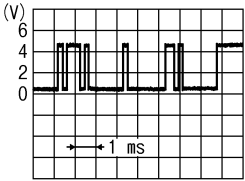
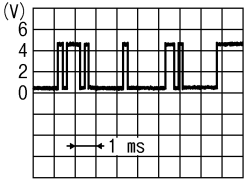
Terminal No. (Wire color)		Description		Condition	Value (Approx.)	
+	-	Signal name	Input/ Output			
24 (G)	Ground	Communication signal (A/C switch assembly→A/C auto amp.)	Input	Ignition switch ON		
25 (W)	Ground	Communication signal (Rear air control→A/C auto amp.)	Input	Ignition switch ON		
26 (G)	—	Sensor ground	—	—	—	
27 (W)	Ground	In-vehicle sensor signal	Input	Ignition switch ON	0 – 4.8 V Output voltage varies with in-vehicle temperature	
28 (W)	Ground	Intake sensor signal	Input	Ignition switch ON	0 – 4.8 V Output voltage varies with front evaporator fin temperature	
32 (L)	Ground	Blower motor feedback	Input	• Ignition switch ON • Blower speed: OFF	Battery voltage	
				• Ignition switch ON • Blower speed: 1st	10 V	
				• Ignition switch ON • Blower speed: 25th	0 V	
34 (L)	Ground	Blower motor feedback	Input	• Ignition switch ON • Blower speed: OFF	Battery voltage	
				• Ignition switch ON • Blower speed: 1st	10 V	
				• Ignition switch ON • Blower speed: 25th	0 V	
37 (BR)	—	Ground	—	—	—	
39 (L)	Ground	PTC2 relay output signal	Input	Ignition switch ON	PTC heater: ON	0 V
				Ignition switch ON	PTC heater: OFF	12 V

*1: With heated steering wheel

Fail-safe

INFOID:000000008901698

FAIL-SAFE FUNCTION

If a communication error exists between the A/C auto amp., and the AV control unit and preset switch for 30 seconds or longer, air conditioning is controlled under the following conditions:

When ambient temperature is less than 3°C (37°F) and engine coolant temperature is less than 56°C (133°F)

Compressor : ON

Air outlet : DEF

A/C AUTO AMP.

< ECU DIAGNOSIS INFORMATION >

[AUTOMATIC AIR CONDITIONING]

Air inlet : FRE (Fresh air intake)
Blower fan speed : AUTO
Set temperature : Setting before communication error occurs

When ambient temperature is 3°C (37°F) or more, or engine coolant temperature is 56°C (133°F) or more

Compressor : ON
Air outlet : AUTO
Air inlet : 20% FRE (20% fresh air intake)
Blower fan speed : AUTO
Set temperature : Setting before communication error occurs

DTC Index

INFOID:000000008901699

DTC	Items (CONSULT screen terms)	Reference
U1000	CAN COMM CIRCUIT	HAC-82, "DTC Logic"
U1010	CONTROL UNIT (CAN)	HAC-83, "DTC Logic"
B2578	IN-VEHICLE SENSOR	HAC-84, "DTC Logic"
B2579	IN-VEHICLE SENSOR	HAC-84, "DTC Logic"
B257B	AMBIENT SENSOR	HAC-87, "DTC Logic"
B257C	AMBIENT SENSOR	HAC-87, "DTC Logic"
B2581	INTAKE SENSOR	HAC-90, "DTC Logic"
B2582	INTAKE SENSOR	HAC-90, "DTC Logic"
B2630*1	SUNLOAD SENSOR	HAC-93, "DTC Logic"
B2631*1	SUNLOAD SENSOR	HAC-93, "DTC Logic"
B2632	DR AIR MIX DOOR MOT	HAC-96, "DTC Logic"
B2633	DR AIR MIX DOOR MOT	HAC-96, "DTC Logic"
B2634	PASS AIR MIX DOOR MOT	HAC-98, "DTC Logic"
B2635	PASS AIR MIX DOOR MOT	HAC-98, "DTC Logic"
B2636	DR VENT DOOR FAIL	HAC-100, "DTC Logic"
B2637	DR B/L DOOR FAIL	HAC-100, "DTC Logic"
B2638	DR D/F1 DOOR FAIL	HAC-100, "DTC Logic"
B2639	DR DEF DOOR FAIL	HAC-100, "DTC Logic"
B263D	FRE DOOR FAIL	HAC-102, "DTC Logic"
B263E	20P FRE DOOR FAIL	HAC-102, "DTC Logic"
B263F	REC DOOR FAIL	HAC-102, "DTC Logic"
B2654	D/F2 DOOR FAIL	HAC-100, "DTC Logic"
B2796	COMMUNICATION ERROR	HAC-104, "DTC Logic"
B2797	COMMUNICATION ERROR	HAC-104, "DTC Logic"
B2798	COMMUNICATION ERROR	HAC-104, "DTC Logic"
B2799	REAR AIR MIX DOOR MOT	HAC-104, "DTC Logic"
B279A	REAR AIR MIX DOOR MOT	HAC-104, "DTC Logic"
B279B	REAR MODE DOOR MOT	HAC-106, "DTC Logic"
B279C	REAR MODE DOOR MOT	HAC-106, "DTC Logic"
B279D	REAR SHUT-OFF DOOR MOT	HAC-106, "DTC Logic"
B279E	REAR SHUT-OFF DOOR MOT	HAC-106, "DTC Logic"
B27B0	A/C AUTO AMP.	HAC-112, "DTC Logic"

A/C AUTO AMP.

< ECU DIAGNOSIS INFORMATION >

[AUTOMATIC AIR CONDITIONING]

*1: Perform self-diagnosis under sunshine. When performing indoors, aim a light (more than 60 W) at sunload sensor, otherwise self-diagnosis indicates even though the sunload sensor is functioning normally.

NOTE:

If all of door motor DTCs (B2632, B2633, B2634, B2635, B2636, B2637, B2638, B2639, B263D, B263E, B263F, B2654, B2799, B279A, B279B, B279C, B279D, and B279E) are detected, check door motor communication circuit. Refer to [HAC-129, "Diagnosis Procedure"](#).

ECM, IPDM E/R, BCM

< ECU DIAGNOSIS INFORMATION >

[AUTOMATIC AIR CONDITIONING]

ECM, IPDM E/R, BCM

List of ECU Reference

INFOID:000000008901700

ECU	Reference
ECM	EC-74. "Reference Value"
	EC-88. "Fail-safe"
	EC-90. "DTC Inspection Priority Chart"
	EC-92. "DTC Index"
IPDM E/R	PCS-12. "Reference Value"
	PCS-19. "Fail Safe"
	PCS-20. "DTC Index"
BCM	BCS-28. "Reference Value"
	BCS-48. "Fail Safe"
	BCS-48. "DTC Inspection Priority Chart"
	BCS-50. "DTC Index"

A
B
C
D
E
F
G
H
J
K
L
M
N
O
P

HAC

AUTOMATIC AIR CONDITIONING SYSTEM

[AUTOMATIC AIR CONDITIONING]

< WIRING DIAGRAM >

- EN : WITHOUT NAVI
- NV : WITH NAVI
- OB : WITHOUT BOSE AUDIO SYSTEM
- VD : WITH AROUND VIEW MONITOR
- VK : WITHOUT AROUND VIEW MONITOR
- WB : WITH BOSE AUDIO SYSTEM

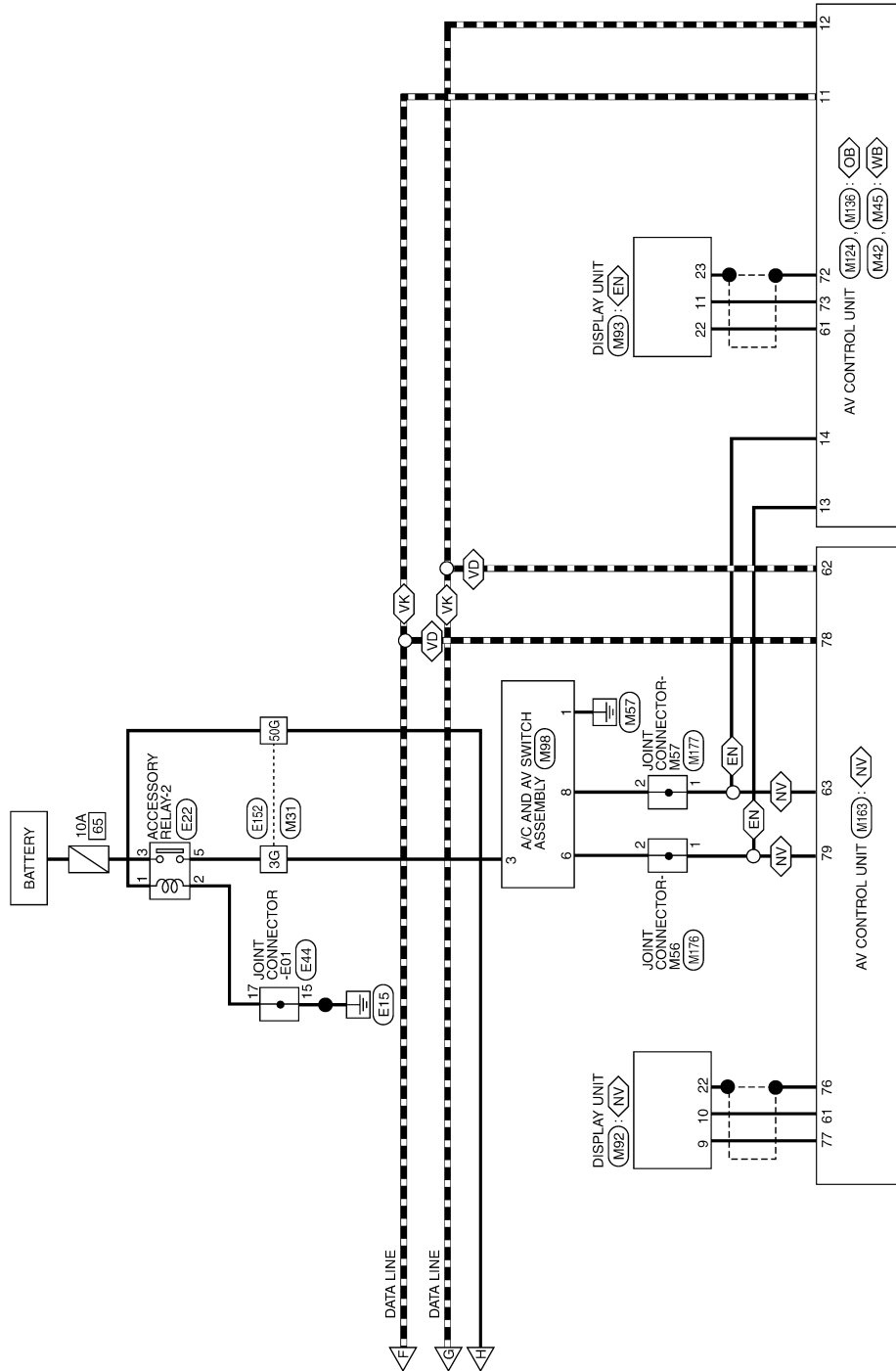

AAIWA0130GB

A
B
C
D
E
F
G
H
HAC
J
K
L
M
N
O
P

AUTOMATIC AIR CONDITIONING SYSTEM

< WIRING DIAGRAM >

[AUTOMATIC AIR CONDITIONING]

AIR CONDITIONER CONTROL CONNECTORS

Connector No.	M3
Connector Name	FUSE BLOCK (J/B)
Connector Color	WHITE

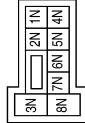

Terminal No.	Color of Wire	Signal Name
3N	L	-
8N	L	-

Connector No.	M4
Connector Name	FUSE BLOCK (J/B)
Connector Color	WHITE



Terminal No.	Color of Wire	Signal Name
7P	LG	-
16P	W	-

Connector No.	M7
Connector Name	WIRE TO WIRE
Connector Color	WHITE



Terminal No.	Color of Wire	Signal Name
1	Y	-
2	BR	-
3	LG	-

Connector No.	M8
Connector Name	WIRE TO WIRE
Connector Color	WHITE



Terminal No.	Color of Wire	Signal Name
1	V	-

Connector No.	M12
Connector Name	REAR SHUT-OFF DOOR MOTOR
Connector Color	WHITE

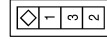

Terminal No.	Color of Wire	Signal Name
1	LG	-
2	Y	-
3	BR	-

Connector No.	M13
Connector Name	MODE DOOR MOTOR (REAR)
Connector Color	WHITE

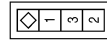

Terminal No.	Color of Wire	Signal Name
1	LG	-
2	Y	-
3	BR	-

AUTOMATIC AIR CONDITIONING SYSTEM

< WIRING DIAGRAM >

[AUTOMATIC AIR CONDITIONING]

Terminal No.	Color of Wire	Signal Name
3G	P	-
8G	G	-
12G	G	-
13G	G	-
35G	P	-
36G	L	-
37G	L	-
38G	W	-
50G	L	-
63G	P	-
94G	O	-

Connector No.	M31
Connector Name	WIRE TO WIRE
Connector Color	WHITE

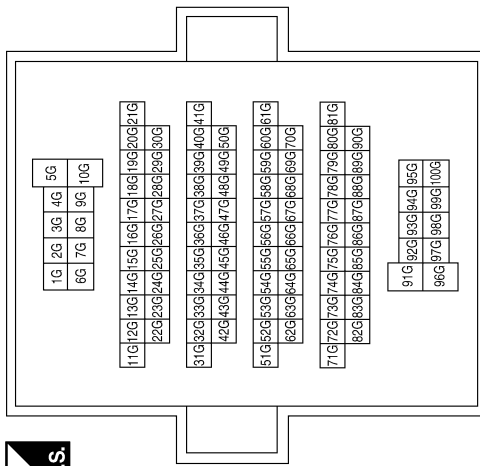

Connector No.	M19
Connector Name	BCM (BODY CONTROL MODULE)
Connector Color	BLACK

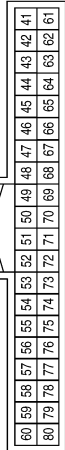

Terminal No.	Color of Wire	Signal Name
59	P	CAN-L
60	L	CAN-H
66	W	BLOWER FAN RELAY OUT
70	P	IGN USM OUT1

A
B
C
D
E
F
G
H
HAC
J
K
L
M
N
O
P

AAIIA0228GB

AUTOMATIC AIR CONDITIONING SYSTEM

[AUTOMATIC AIR CONDITIONING]

< WIRING DIAGRAM >

Connector No.	M41
Connector Name	JOINT CONNECTOR-M18
Connector Color	WHITE



Terminal No.	Color of Wire	Signal Name
1	P	-
2	P	-

Terminal No.	Color of Wire	Signal Name
89A	L	-
90A	P	-

Connector No.	M40
Connector Name	WIRE TO WIRE
Connector Color	WHITE

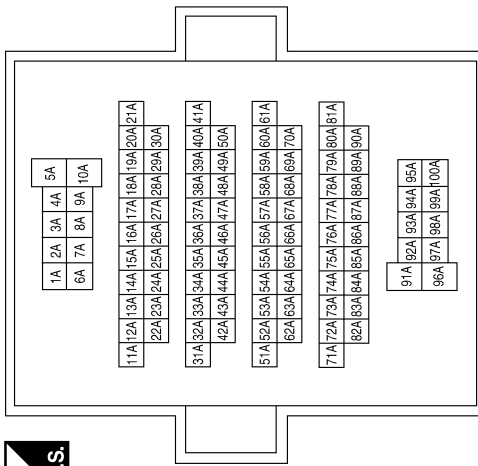

Connector No.	M45
Connector Name	AV CONTROL UNIT (MID AUDIO WITH BOSE)
Connector Color	WHITE

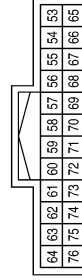

Terminal No.	Color of Wire	Signal Name
61	B	DISP IT
72	SHIELD	SHIELD
73	W	IT DISP

Connector No.	M43
Connector Name	JOINT CONNECTOR-M17
Connector Color	WHITE

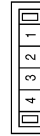

Terminal No.	Color of Wire	Signal Name
1	L	-
2	L	-

Connector No.	M42
Connector Name	AV CONTROL UNIT (MID AUDIO WITH BOSE)
Connector Color	WHITE

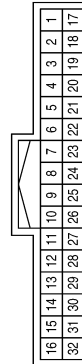

Terminal No.	Color of Wire	Signal Name
11	L	CAN-H
12	P	CAN-L
13	SB	M-CAN1 H
14	LG	M-CAN1 L

AA11A0229GB

AUTOMATIC AIR CONDITIONING SYSTEM

[AUTOMATIC AIR CONDITIONING]

< WIRING DIAGRAM >

Terminal No.	Color of Wire	Signal Name
25	W	RX RR
26	G	SENS GND
27	W	INC SENS
28	W	INT SENS
29	-	-
30	-	-
31	-	-
32	L	FAN F/B (COOLER)
33	-	-
34	L	FAN F/B (BOOSTER)
35	-	-
36	-	-
37	BR	ACTR GND
38	-	-
39	L	PTC2
40	-	-

Terminal No.	Color of Wire	Signal Name
8	G	STRG HTR SW
9	W	SUN SENS
10	-	-
11	-	-
12	G	FAN OUT (COOLER)
13	W	IGN2
14	W	FAN OUT (BOOSTER)
15	-	-
16	Y	ACTR (LIN)
17	LG	VACTR
18	W	FR FAN PWM
19	W	PTC1
20	BR	STRG HTR RLY
21	P	CAN-L
22	GR	GND (POWER)
23	LG	IGN
24	-	-

Connector No.	M50
Connector Name	A/C AUTO AMP.
Connector Color	WHITE



1	2	3	4	5	6	7	8	9	10	11	12	13	14	15	16	17	18	19	20	21	22	23	24	25	26	27	28	29	30	31	32	33	34	35	36	37	38	39	40
---	---	---	---	---	---	---	---	---	----	----	----	----	----	----	----	----	----	----	----	----	----	----	----	----	----	----	----	----	----	----	----	----	----	----	----	----	----	----	----

Terminal No.	Color of Wire	Signal Name
1	L	CAN-H
2	GR	GND
3	G	BATT
4	-	-
5	G	TX RR
6	-	-
7	G	AMB SENS

Connector No.	M68
Connector Name	FUSE BLOCK (J/B)
Connector Color	BROWN



1	2	3	4	5	6	7	8	9	10	11	12	13	14	15	16	17	18	19	20	21	22	23	24	25	26	27	28	29	30	31	32	33	34	35	36	37	38	39	40
---	---	---	---	---	---	---	---	---	----	----	----	----	----	----	----	----	----	----	----	----	----	----	----	----	----	----	----	----	----	----	----	----	----	----	----	----	----	----	----

Connector No.	M65
Connector Name	WIRE TO WIRE
Connector Color	WHITE



1	2	3	4	5	6	7	8	9	10	11	12	13	14	15	16
---	---	---	---	---	---	---	---	---	----	----	----	----	----	----	----

Connector No.	M56
Connector Name	WIRE TO WIRE
Connector Color	WHITE



1	2	3	4	5	6	7	8	9	10	11	12	13	14	15	16	17	18	19	20	21	22	23	24
---	---	---	---	---	---	---	---	---	----	----	----	----	----	----	----	----	----	----	----	----	----	----	----

Terminal No.	Color of Wire	Signal Name
3R	G	-
13R	GR	-

Terminal No.	Color of Wire	Signal Name
10	B	-

Terminal No.	Color of Wire	Signal Name
22	LG	-
23	W	-
24	G	-

AA1IA0230GB

A
B
C
D
E
F
G
H
HAC
J
K
L
M
N
O
P

AUTOMATIC AIR CONDITIONING SYSTEM

< WIRING DIAGRAM >

[AUTOMATIC AIR CONDITIONING]

Connector No.	M84
Connector Name	WIRE TO WIRE
Connector Color	WHITE

Terminal No.	Color of Wire	Signal Name
17	L	-
18	P	-
23	G	-

Connector No.	M80
Connector Name	BCM (BODY CONTROL MODULE)
Connector Color	BLACK

Terminal No.	Color of Wire	Signal Name
113	L	ACC RELAY OUT

Connector No.	M75
Connector Name	WIRE TO WIRE
Connector Color	WHITE

Terminal No.	Color of Wire	Signal Name
2	G	-
3	W	-

Connector No.	M98
Connector Name	A/C AND AV SWITCH ASSEMBLY
Connector Color	WHITE

Terminal No.	Color of Wire	Signal Name
1	B	-
3	P	-
6	SB	-
8	LG	-

Connector No.	M93
Connector Name	DISPLAY UNIT (WITHOUT NAVIGATION SYSTEM)
Connector Color	WHITE

Terminal No.	Color of Wire	Signal Name
11	W	UART IN
22	B	UART OUT
23	SHIELD	UART GND

Connector No.	M92
Connector Name	DISPLAY UNIT (WITH NAVIGATION SYSTEM)
Connector Color	WHITE

Terminal No.	Color of Wire	Signal Name
9	B	FRONT DISP IT
10	W	IT FRONT DISP
22	SHIELD	SHIELD

AA1IA0231GB

AUTOMATIC AIR CONDITIONING SYSTEM

< WIRING DIAGRAM >

[AUTOMATIC AIR CONDITIONING]

Connector No.	M103
Connector Name	INTAKE SENSOR
Connector Color	WHITE



Terminal No.	Color of Wire	Signal Name
1	W	-
2	G	-

Connector No.	M102
Connector Name	IN-VEHICLE SENSOR
Connector Color	WHITE



Terminal No.	Color of Wire	Signal Name
1	W	-
2	G	-

Connector No.	M101
Connector Name	SUNLOAD SENSOR
Connector Color	BLACK



Terminal No.	Color of Wire	Signal Name
1	W	-
2	G	-

Connector No.	M108
Connector Name	REAR BLOWER MOTOR RELAY
Connector Color	BROWN



Terminal No.	Color of Wire	Signal Name
1	W	-
2	GR	-
3	O	-
5	W	-
6	G	-
7	V	-

Connector No.	M107
Connector Name	REAR BLOWER MOTOR 1
Connector Color	WHITE



Terminal No.	Color of Wire	Signal Name
1	W	-
2	L	-

Connector No.	M104
Connector Name	REAR BLOWER MOTOR RESISTOR 1
Connector Color	WHITE



Terminal No.	Color of Wire	Signal Name
1	L	-
2	W	-
3	B	-

AA1IA0232GB

A
B
C
D
E
F
G
H
HAC
J
K
L
M
N
O
P

AUTOMATIC AIR CONDITIONING SYSTEM

< WIRING DIAGRAM >

[AUTOMATIC AIR CONDITIONING]

Connector No.	M118
Connector Name	PTC HEATER
Connector Color	WHITE

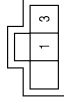

Terminal No.	Color of Wire	Signal Name
1	W	-
3	G	-

Connector No.	M117
Connector Name	PTC HEATER
Connector Color	WHITE



Terminal No.	Color of Wire	Signal Name
2	GR	-
4	B	-

Connector No.	M112
Connector Name	FRONT BLOWER MOTOR
Connector Color	WHITE

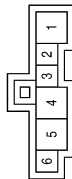

Terminal No.	Color of Wire	Signal Name
1	GR	-
3	W	-
4	L	-

Connector No.	M128
Connector Name	INTAKE DOOR MOTOR
Connector Color	WHITE



Terminal No.	Color of Wire	Signal Name
1	GR	-
2	GR	-
3	GR	-

Connector No.	M127
Connector Name	WIRE TO WIRE
Connector Color	WHITE



Terminal No.	Color of Wire	Signal Name
1	GR	-
2	GR	-
3	GR	-

Connector No.	M124
Connector Name	AV CONTROL UNIT (MID AUDIO WITHOUT BOSE)
Connector Color	WHITE

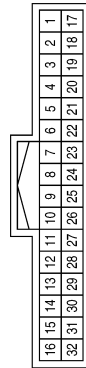

Terminal No.	Color of Wire	Signal Name
11	L	CAN-H
12	P	CAN-L
13	SB	M-CAN H
14	LG	M-CAN L

AA1IA0233GB

AUTOMATIC AIR CONDITIONING SYSTEM

< WIRING DIAGRAM >

[AUTOMATIC AIR CONDITIONING]

Connector No.	M131
Connector Name	AIR MIX DOOR MOTOR PASSENGER SIDE
Connector Color	WHITE



Terminal No.	Color of Wire	Signal Name
1	GR	-
2	GR	-
3	GR	-

Connector No.	M130
Connector Name	AIR MIX DOOR MOTOR DRIVER SIDE
Connector Color	WHITE

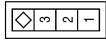

Terminal No.	Color of Wire	Signal Name
1	GR	-
2	GR	-
3	GR	-

Connector No.	M129
Connector Name	MODE DOOR MOTOR (FRONT)
Connector Color	WHITE

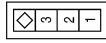

Terminal No.	Color of Wire	Signal Name
1	GR	-
2	GR	-
3	GR	-

Connector No.	M146
Connector Name	A/C SWITCH ASSEMBLY
Connector Color	WHITE

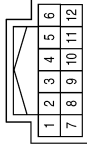

Terminal No.	Color of Wire	Signal Name
1	LG	-
2	B	-
3	W	-
4	G	-
5	R	-
6	B	-
7	-	-
8	-	-
9	-	-
10	-	-
11	-	-
12	-	-

Connector No.	M136
Connector Name	AUDIO CONTROL UNIT (MID AUDIO WITHOUT BOSE)
Connector Color	WHITE

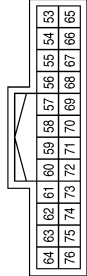

Terminal No.	Color of Wire	Signal Name
61	B	DISP IT
72	SHIELD	DISP SHIELD
73	W	IT DISPLAY

Connector No.	M132
Connector Name	AIR MIX DOOR MOTOR (REAR)
Connector Color	WHITE



Terminal No.	Color of Wire	Signal Name
1	GR	-
2	GR	-
3	GR	-

AA11A0234GB

A
B
C
D
E
F
G
H
HAC
J
K
L
M
N
O
P

AUTOMATIC AIR CONDITIONING SYSTEM

[AUTOMATIC AIR CONDITIONING]

< WIRING DIAGRAM >

Connector No.	M163
Connector Name	AV CONTROL UNIT (PREMIUM AUDIO WITH NAVIGATION)
Connector Color	WHITE

49	50	51	52	53	54	55	56	57	58	59	60	61	62	63	64
65	66	67	68	69	70	71	72	73	74	75	76	77	78	79	80

Terminal No.	Color of Wire	Signal Name
61	W	IT DISP
62	P	CAN-L
63	LG	M-CAN L
76	SHIELD	DISP SHIELD
77	B	DISP IT
78	L	CAN-H
79	SB	M-CAN H

Connector No.	M157
Connector Name	WIRE TO WIRE
Connector Color	WHITE

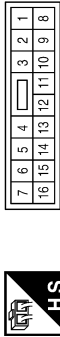

Terminal No.	Color of Wire	Signal Name
13	L	-

Connector No.	M148
Connector Name	A/C DISPLAY UNIT
Connector Color	BLACK

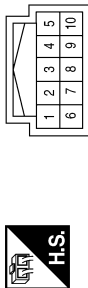

Terminal No.	Color of Wire	Signal Name
1	B	-
2	-	-
3	-	-
4	-	-
5	-	-
6	LG	-
7	-	-
8	R	-
9	B	-
10	W	-

Connector No.	M177
Connector Name	JOINT CONNECTOR-M57
Connector Color	WHITE



Terminal No.	Color of Wire	Signal Name
1	LG	-
2	LG	-

Connector No.	M176
Connector Name	JOINT CONNECTOR-M56
Connector Color	WHITE



Terminal No.	Color of Wire	Signal Name
1	SB	-
2	SB	-

Connector No.	M170
Connector Name	JOINT CONNECTOR-M09
Connector Color	WHITE

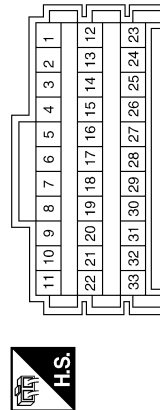

Terminal No.	Color of Wire	Signal Name
12	G	-
14	G	-
15	G	-
16	G	-
17	G	-

AA1IA0235GB

AUTOMATIC AIR CONDITIONING SYSTEM

< WIRING DIAGRAM >

[AUTOMATIC AIR CONDITIONING]

Connector No.	M217
Connector Name	WIRE TO WIRE
Connector Color	WHITE

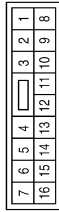

Terminal No.	Color of Wire	Signal Name
10	B	-

Connector No.	M214
Connector Name	WIRE TO WIRE
Connector Color	WHITE

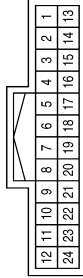

Terminal No.	Color of Wire	Signal Name
22	LG	-
23	W	-
24	G	-

Connector No.	M202
Connector Name	WIRE TO WIRE
Connector Color	WHITE



Terminal No.	Color of Wire	Signal Name
13	B	-
14	LG	-
15	W	-
16	G	-

Connector No.	E2
Connector Name	WIRE TO WIRE
Connector Color	WHITE



Terminal No.	Color of Wire	Signal Name
12	Y	-
13	LG	-
14	V	-

Connector No.	M258
Connector Name	REAR AIR CONTROL
Connector Color	WHITE

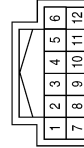

Terminal No.	Color of Wire	Signal Name
1	B	-
5	R	-
6	B	-
9	G	-
10	W	-
12	LG	-

Connector No.	M257
Connector Name	WIRE TO WIRE
Connector Color	WHITE

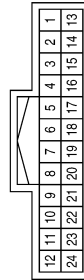

Terminal No.	Color of Wire	Signal Name
13	B	-
14	LG	-
15	W	-
16	G	-

AA1IA0236GB

A
B
C
D
E
F
G
H
HAC
J
K
L
M
N
O
P

AUTOMATIC AIR CONDITIONING SYSTEM

< WIRING DIAGRAM >

[AUTOMATIC AIR CONDITIONING]

Connector No.	E16
Connector Name	ECM
Connector Color	GRAY

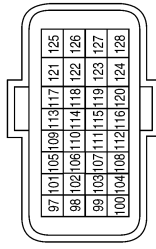

Terminal No.	Color of Wire	Signal Name
113	P	CAN-L
114	L	CAN-H

Connector No.	E12
Connector Name	PTC RELAY-2
Connector Color	BLUE



Terminal No.	Color of Wire	Signal Name
1	R	-
2	BG	-
3	W	-
5	P	-

Connector No.	E11
Connector Name	PTC RELAY-1
Connector Color	BLUE



Terminal No.	Color of Wire	Signal Name
1	R	-
2	W	-
3	Y	-
5	Y	-

Connector No.	E26
Connector Name	WIRE TO WIRE
Connector Color	WHITE

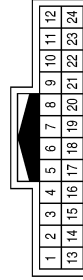

Terminal No.	Color of Wire	Signal Name
18	P	-
19	W	-

Connector No.	E22
Connector Name	ACCESSORY RELAY-2
Connector Color	BLUE



Terminal No.	Color of Wire	Signal Name
1	G	-
2	B	-
3	R	-
5	P	-

Connector No.	E19
Connector Name	WIRE TO WIRE
Connector Color	WHITE

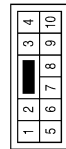

Terminal No.	Color of Wire	Signal Name
10	GR	-

AAIIA0237GB

AUTOMATIC AIR CONDITIONING SYSTEM

< WIRING DIAGRAM >

[AUTOMATIC AIR CONDITIONING]

Connector No.	E44
Connector Name	JOINT CONNECTOR-E01
Connector Color	WHITE

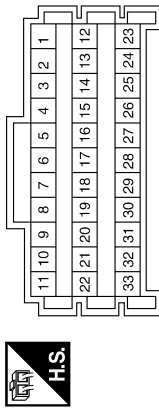

Terminal No.	Color of Wire	Signal Name
15	GR	-
17	B	-

Connector No.	E36
Connector Name	WIRE TO WIRE
Connector Color	WHITE

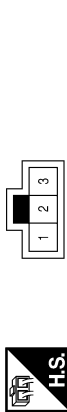

Terminal No.	Color of Wire	Signal Name
2	P	-
3	Y	-

Connector No.	E28
Connector Name	FUSE BLOCK (J/B)
Connector Color	WHITE

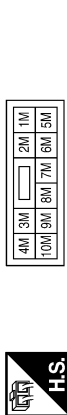

Terminal No.	Color of Wire	Signal Name
1M	R	-

Connector No.	E71
Connector Name	JOINT CONNECTOR-E15
Connector Color	BLACK

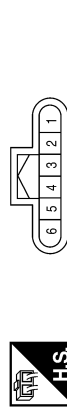

Terminal No.	Color of Wire	Signal Name
1	L	-
2	L	-

Connector No.	E70
Connector Name	JOINT CONNECTOR-E14
Connector Color	BLACK

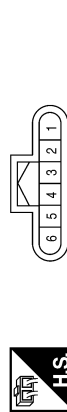

Terminal No.	Color of Wire	Signal Name
1	P	-
2	P	-

Connector No.	E45
Connector Name	JOINT CONNECTOR-E12
Connector Color	BLUE

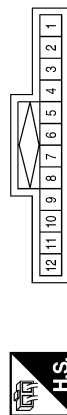

Terminal No.	Color of Wire	Signal Name
1	L	-
2	L	-
4	L	-
7	P	-
8	P	-
10	P	-

AA11A0238GB

A
B
C
D
E
F
G
H
HAC
J
K
L
M
N
O
P

AUTOMATIC AIR CONDITIONING SYSTEM

[AUTOMATIC AIR CONDITIONING]

< WIRING DIAGRAM >

Connector No.	E121
Connector Name	IPDM E/R (INTELLIGENT POWER DISTRIBUTION MODULE ENGINE ROOM)
Connector Color	WHITE

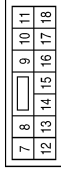

Terminal No.	Color of Wire	Signal Name
7	B	GND (POWER)

Terminal No.	Color of Wire	Signal Name
28	P	CAN-L
29	L	CAN-H
41	B	GND (SIGNAL)
43	L	IGN SIGNAL
45	LG	PD SENS SIG-E/R
47	Y	PD SENS PWR-E/R
48	V	PD SENS GND-E/R

Connector No.	E119
Connector Name	IPDM E/R (INTELLIGENT POWER DISTRIBUTION MODULE ENGINE ROOM)
Connector Color	WHITE

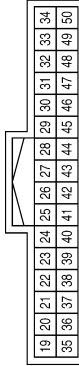

Connector No.	E206
Connector Name	AMBIENT SENSOR
Connector Color	BLACK



Terminal No.	Color of Wire	Signal Name
1	L	-
2	Y	-

Terminal No.	Color of Wire	Signal Name
3G	P	-
8G	G	-
12G	P	-
13G	W	-
35G	P	-
36G	L	-
37G	BG	-
38G	W	-
50G	G	-
63G	L	-
94G	Y	-

Connector No.	E152
Connector Name	WIRE TO WIRE
Connector Color	WHITE

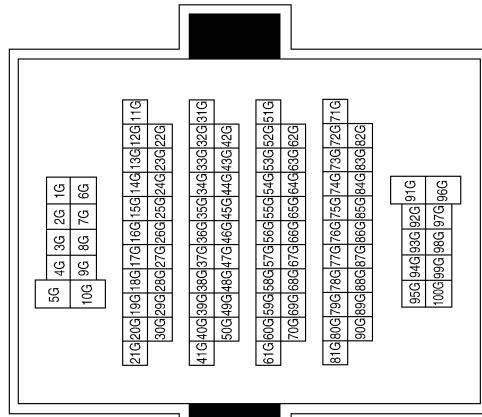

AA11A0239GB

AUTOMATIC AIR CONDITIONING SYSTEM

< WIRING DIAGRAM >

[AUTOMATIC AIR CONDITIONING]

Connector No.	E244
Connector Name	REFRIGERANT PRESSURE SENSOR
Connector Color	BLACK



Terminal No.	Color of Wire	Signal Name
1	G	-
2	P	-
3	L	-

Connector No.	E218
Connector Name	IPDM E/R (INTELLIGENT POWER DISTRIBUTION MODULE ENGINE ROOM)
Connector Color	WHITE

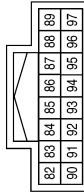

Terminal No.	Color of Wire	Signal Name
82	P	PD SENS SIG-FEM
83	G	PD SENS PWR-FEM
86	L	PD SENS GND-FEM

Connector No.	E209
Connector Name	WIRE TO WIRE
Connector Color	WHITE

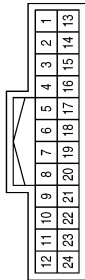

Terminal No.	Color of Wire	Signal Name
18	L	-
19	Y	-

Connector No.	F32
Connector Name	WIRE TO WIRE
Connector Color	WHITE

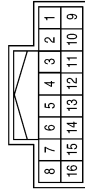

Terminal No.	Color of Wire	Signal Name
12	P	-
13	SB	-
14	V	-

Connector No.	F19
Connector Name	IPDM E/R (INTELLIGENT POWER DISTRIBUTION MODULE ENGINE ROOM)
Connector Color	WHITE

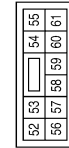

Terminal No.	Color of Wire	Signal Name
56	SB	A/C COMP

Connector No.	F3
Connector Name	A/C COMPRESSOR
Connector Color	BLACK



Terminal No.	Color of Wire	Signal Name
1	SB	-
2	B	-

AA1IA0240GB

A
B
C
D
E
F
G
H
HAC
J
K
L
M
N
O
P

AUTOMATIC AIR CONDITIONING SYSTEM

< WIRING DIAGRAM >

[AUTOMATIC AIR CONDITIONING]

Connector No.	B11
Connector Name	JOINT CONNECTOR-B09
Connector Color	WHITE



4	3	2	1
---	---	---	---

Terminal No.	Color of Wire	Signal Name
1	P	-
2	P	-

Connector No.	F52
Connector Name	ECM
Connector Color	BROWN



96	92	88	84	80	76	72	68	64	60	56	52
95	91	87	83	79	75	71	67	63	59	55	51
94	90	86	82	78	74	70	66	62	58	54	50
93	89	85	81	77	73	69	65	61	57	53	49

Terminal No.	Color of Wire	Signal Name
63	SB	REFRIGERANT PRESSURE SENSOR
64	V	SENSOR GROUND (REFRIGERANT PRESSURE SENSOR)
96	P	SENSOR POWER SUPPLY (REFRIGERANT PRESSURE SENSOR)

Connector No.	F33
Connector Name	WIRE TO WIRE
Connector Color	WHITE



4	3	2	1
10	9	8	7
6	5		

Terminal No.	Color of Wire	Signal Name
10	B	-

Connector No.	B17
Connector Name	JOINT CONNECTOR-B12
Connector Color	WHITE



4	3	2	1
---	---	---	---

Terminal No.	Color of Wire	Signal Name
1	L	-
2	L	-

Connector No.	B16
Connector Name	JOINT CONNECTOR-B11
Connector Color	WHITE



4	3	2	1
---	---	---	---

Terminal No.	Color of Wire	Signal Name
1	P	-
2	P	-

Connector No.	B12
Connector Name	JOINT CONNECTOR-B10
Connector Color	WHITE



4	3	2	1
---	---	---	---

Terminal No.	Color of Wire	Signal Name
1	L	-
2	L	-

AA1IA0241GB

AUTOMATIC AIR CONDITIONING SYSTEM

< WIRING DIAGRAM >

[AUTOMATIC AIR CONDITIONING]

Terminal No.	Color of Wire	Signal Name
89A	L	-
90A	P	-

Connector No.	B69
Connector Name	WIRE TO WIRE
Connector Color	WHITE

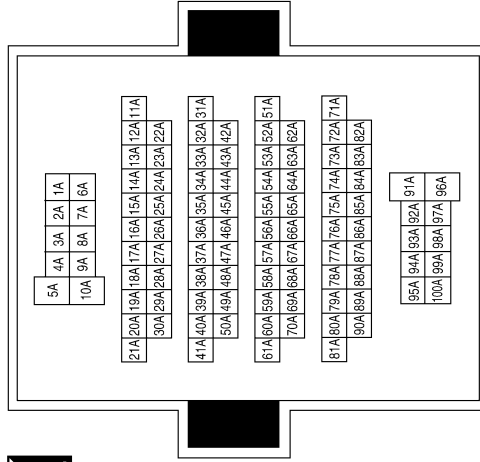

Connector No.	B32
Connector Name	WIRE TO WIRE
Connector Color	WHITE

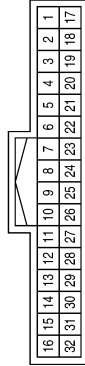

Terminal No.	Color of Wire	Signal Name
18	L	-
19	P	-

Connector No.	B124
Connector Name	WIRE TO WIRE
Connector Color	WHITE



Connector No.	B106
Connector Name	WIRE TO WIRE
Connector Color	WHITE



Terminal No.	Color of Wire	Signal Name
18	L	-
19	P	-

Connector No.	B101
Connector Name	WIRE TO WIRE
Connector Color	WHITE

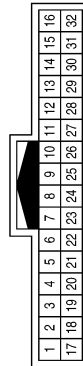

Terminal No.	Color of Wire	Signal Name
17	L	-
18	P	-
23	W	-

AA11A0242GB

A
B
C
D
E
F
G
H
HAC
J
K
L
M
N
O
P

AUTOMATIC AIR CONDITIONING SYSTEM

< WIRING DIAGRAM >

[AUTOMATIC AIR CONDITIONING]

Connector No.	B161
Connector Name	WIRE TO WIRE
Connector Color	WHITE

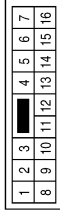

Terminal No.	13	Color of Wire	SB	Signal Name	-
--------------	----	---------------	----	-------------	---

Connector No.	B134
Connector Name	REAR BLOWER MOTOR 2
Connector Color	WHITE



Terminal No.	1	Color of Wire	W	Signal Name	-
	2	Color of Wire	SB	Signal Name	-

Connector No.	B133
Connector Name	REAR BLOWER MOTOR RESISTOR 2
Connector Color	WHITE



Terminal No.	1	Color of Wire	SB	Signal Name	-
	2	Color of Wire	W	Signal Name	-
	3	Color of Wire	GR	Signal Name	-

AA1IA0243GB

DIAGNOSIS AND REPAIR WORK FLOW

< BASIC INSPECTION >

[AUTOMATIC AIR CONDITIONING]

BASIC INSPECTION

DIAGNOSIS AND REPAIR WORK FLOW

Work Flow

INFOID:000000008901701

OVERALL SEQUENCE

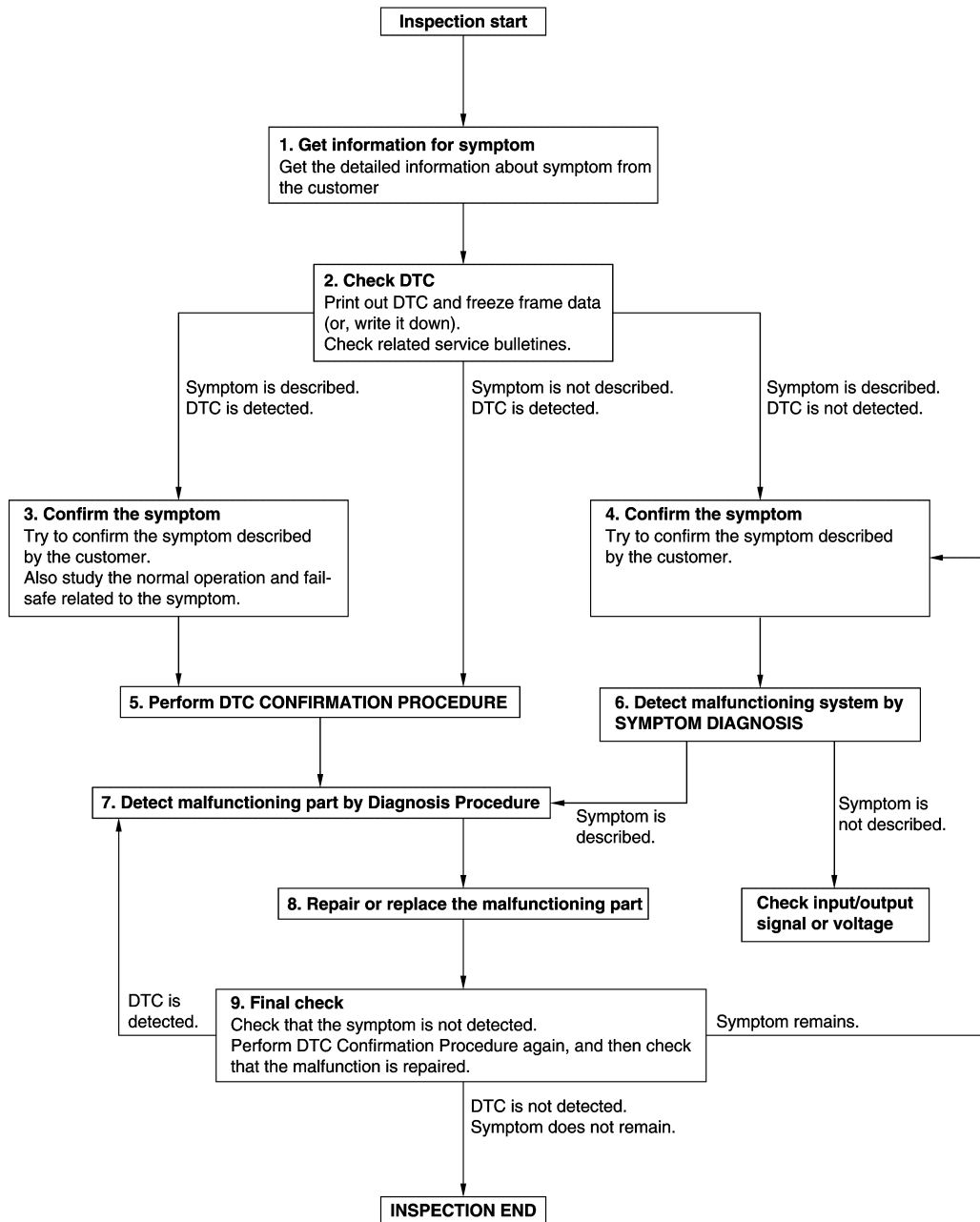

DETAILED FLOW

DIAGNOSIS AND REPAIR WORK FLOW

[AUTOMATIC AIR CONDITIONING]

< BASIC INSPECTION >

1. GET INFORMATION FOR SYMPTOM

1. Get detailed information from the customer about the symptom (the condition and the environment when the incident/malfunction occurs).
2. Check operation condition of the function that is malfunctioning.

>> GO TO 2.

2. CHECK DTC

1. Check DTC.
2. Perform the following procedure if DTC is detected.
 - Record DTC and freeze frame data (Print them out using CONSULT.)
 - Erase DTC.
 - Study the relationship between the cause detected by DTC and the symptom described by the customer.
3. Check related service bulletins for information.

Are any symptoms described and any DTC detected?

Symptom is described, DTC is detected>>GO TO 3.

Symptom is described, DTC is not detected>>GO TO 4.

Symptom is not described, DTC is detected>>GO TO 5.

3. CONFIRM THE SYMPTOM

Try to confirm the symptom described by the customer.

Also study the normal operation and fail-safe related to the symptom.

Verify relation between the symptom and the condition when the symptom is detected.

>> GO TO 5.

4. CONFIRM THE SYMPTOM

Try to confirm the symptom described by the customer.

Verify relation between the symptom and the condition when the symptom is detected.

>> GO TO 6.

5. PERFORM DTC CONFIRMATION PROCEDURE

Perform DTC CONFIRMATION PROCEDURE for the detected DTC, and then check that DTC is detected again. At this time, always connect CONSULT to the vehicle, and check self diagnostic results in real time. If two or more DTCs are detected, refer to DTC INSPECTION PRIORITY CHART, and determine trouble diagnosis order.

NOTE:

- Freeze frame data is useful if the DTC is not detected.
- Perform Component Function Check if DTC CONFIRMATION PROCEDURE is not included on Service Manual. This simplified check procedure is an effective alternative though DTC cannot be detected during this check.
If the result of Component Function Check is NG, it is the same as the detection of DTC by DTC CONFIRMATION PROCEDURE.

Is DTC detected?

YES >> GO TO 7.

NO >> Check according to [GI-49. "Intermittent Incident"](#).

6. DETECT MALFUNCTIONING SYSTEM BY SYMPTOM DIAGNOSIS

Detect malfunctioning system according to SYMPTOM DIAGNOSIS based on the confirmed symptom in step 4, and determine the trouble diagnosis order based on possible causes and symptom.

Is the symptom described?

YES >> GO TO 7.

NO >> Monitor input data from related sensors or check voltage of related module terminals using CONSULT.

7. DETECT MALFUNCTIONING PART BY DIAGNOSIS PROCEDURE

DIAGNOSIS AND REPAIR WORK FLOW

[AUTOMATIC AIR CONDITIONING]

< BASIC INSPECTION >

Inspect according to Diagnosis Procedure of the system.

Is malfunctioning part detected?

YES >> GO TO 8.

NO >> Check according to [GI-49. "Intermittent Incident"](#).

8. REPAIR OR REPLACE THE MALFUNCTIONING PART

1. Repair or replace the malfunctioning part.
2. Reconnect parts or connectors disconnected during Diagnosis Procedure again after repair and replacement.
3. Check DTC. If DTC is detected, erase it.

>> GO TO 9.

9. FINAL CHECK

When DTC is detected in step 2, perform DTC CONFIRMATION PROCEDURE again, and then check that the malfunction is repaired securely.

When symptom is described by the customer, refer to confirmed symptom in step 3 or 4, and check that the symptom is not detected.

Is DTC detected and does symptom remain?

YES-1 >> DTC is detected: GO TO 7.

YES-2 >> Symptom remains: GO TO 4.

NO >> Before returning the vehicle to the customer, always erase DTC.

A
B
C
D
E
F
G
H
J
K
L
M
N
O
P

HAC

OPERATION INSPECTION

< BASIC INSPECTION >

[AUTOMATIC AIR CONDITIONING]

OPERATION INSPECTION

FRONT AUTOMATIC AIR CONDITIONING SYSTEM

FRONT AUTOMATIC AIR CONDITIONING SYSTEM : Work Procedure

INFOID:000000008901702

DESCRIPTION

The purpose of the operational check is to check that the individual system operates normally.

Check condition : Engine running at normal operating temperature.

OPERATION INSPECTION

1. CHECK MEMORY FUNCTION

1. Set temperature control (driver side) to 32.0°C (90°F).
2. Press OFF switch.
3. Turn ignition switch OFF.
4. Turn ignition switch ON.
5. Press AUTO switch.
6. Check that set temperature is maintained.

Is the inspection result normal?

- YES >> GO TO 2.
NO >> GO TO 10.

2. CHECK FRONT BLOWER MOTOR

1. Start engine.
2. Operate fan switch.
3. Check that fan speed changes. Check operation for all fan speeds.

Is the inspection result normal?

- YES >> GO TO 3.
NO >> GO TO 10.

3. CHECK DISCHARGE AIR (MODE SWITCH AND DEF SWITCH)

1. Operate fan switch to set the fan speed to maximum speed.
2. Operate MODE switch and DEF switch.
3. Check that air outlets change according to each indicated air outlet by placing a hand in front of the outlets. Refer to [HAC-19, "FRONT AUTOMATIC AIR CONDITIONING SYSTEM : System Description"](#).

Is the inspection result normal?

- YES >> GO TO 4.
NO >> GO TO 10.

4. CHECK INTAKE AIR

1. Press REC switch to set the air inlet to recirculation. The REC switch indicator turns ON.
2. Listen to intake sound and confirm air inlets change.
3. Press REC switch again to set the air inlet to fresh air intake. The REC switch indicator turns OFF.
4. Listen to intake sound and confirm air inlets change.

Is the inspection result normal?

- YES >> GO TO 5.
NO >> GO TO 10.

5. CHECK DISCHARGE AIR TEMPERATURE (LH/RH INDEPENDENT TEMPERATURE ADJUSTMENT FUNCTION)

1. Operate temperature control (driver side).
2. Check that discharge air temperature (driver side) changes.
3. Operate temperature control (passenger side). The DUAL switch indicator is turns ON.
4. Check that the discharge air temperature (passenger side) changes.
5. Press DUAL switch. The DUAL switch indicator turns OFF.
6. Check that air temperature setting (LH/RH) is unified to the driver side temperature setting.

Is the inspection result normal?

OPERATION INSPECTION

[AUTOMATIC AIR CONDITIONING]

< BASIC INSPECTION >

- YES >> GO TO 6.
NO >> GO TO 10.

6.CHECK WITH TEMPERATURE SETTING LOWERED

1. Operate compressor.
2. Operate temperature control (driver side) and lower the set temperature to 18°C (60°F).
3. Check that cool air blows from the air outlets.

Is the inspection result normal?

- YES >> GO TO 7.
NO >> GO TO 10.

7.CHECK TEMPERATURE INCREASE

1. Operate temperature control (driver side) and raise the set temperature to 32°C (90°F).
2. Check that warm air blows from the air outlets.

Is the inspection result normal?

- YES >> GO TO 8.
NO >> GO TO 10.

8.CHECK AUTO MODE

1. Press AUTO switch to confirm that "AUTO" is indicated on the display.
2. Operate temperature control (driver side) to check that fan speed or air outlet changes (the air outlet or fan speed varies depending on the ambient temperature, in-vehicle temperature, set temperature, etc.).

Is the inspection result normal?

- YES >> GO TO 9.
NO >> GO TO 10.

9.CHECK INTELLIGENT KEY INTERLOCK FUNCTION

1. Operate temperature control (driver side) to 32.0°C (90°F).
2. Operate fan switch. Set fan speed to 1st speed.
3. Turn ignition switch OFF.
4. Lock door using Intelligent Key or driver door request switch.
5. Switch to another Intelligent Key and unlock door using Intelligent Key or driver door request switch.
6. Turn ignition switch ON.
7. Operate fan switch. Set fan speed to 7th speed.
8. Operate temperature control (driver side). Decrease setting temperature to 18.0°C (60°F).
9. Turn ignition switch OFF.
10. Lock door using Intelligent Key or driver door request switch.
11. Switch to another Intelligent Key and unlock door using Intelligent Key or driver door request switch.
12. Turn ignition switch ON.
13. Check that "Connection with the key has been done." is indicated on display and that air conditioning system starts to operate automatically by setting temperature to 32.0°C (90°F) and fan speed to 1st.

Is the inspection result normal?

- YES >> Inspection End.
NO >> GO TO 10.

10.CHECK SELF-DIAGNOSIS WITH CONSULT

1. Perform self-diagnosis with CONSULT.
2. Check that any DTC is detected.

Is any DTC detected?

- YES >> Refer to [HAC-47, "DTC Index"](#) and perform the appropriate diagnosis.
NO >> GO TO 11.

11.CHECK FAIL-SAFE ACTIVATION

Check that symptom is applied to the fail-safe activation. Refer to [HAC-46, "Fail-safe"](#).

>> Refer to [HAC-145, "Diagnosis Chart By Symptom"](#) and perform the appropriate diagnosis.

REAR AUTOMATIC AIR CONDITIONING SYSTEM

OPERATION INSPECTION

< BASIC INSPECTION >

[AUTOMATIC AIR CONDITIONING]

REAR AUTOMATIC AIR CONDITIONING SYSTEM : Work Procedure

INFOID:000000008901703

DESCRIPTION

The purpose of the operational check is to check that the individual system operates normally.

NOTE:

Check that front automatic air conditioning system operates normally. Refer to [HAC-145. "Diagnosis Chart By Symptom"](#).

Check condition : Engine running at normal operating temperature.
: Front air conditioning system operate.

OPERATION INSPECTION

Front A/C Control Operation

1. CHECK REAR CONTROL MODE FUNCTION

1. Press REAR switch. The REAR switch indicator turns ON.
2. Check that display unit changes to state indication display (rear control mode) and that rear automatic air conditioning system starts.
3. Press REAR switch again. The REAR switch indicator turns OFF.
4. Check that rear control mode released. (rear automatic air conditioning system operates continuously)

Is the inspection result normal?

YES >> GO TO 2.
NO >> GO TO 8.

2. CHECK REAR BLOWER MOTOR

1. Press REAR switch.
2. Operate fan switch.
3. Check that fan speed changes. Check operation for all fan speeds.

Is the inspection result normal?

YES >> GO TO 3.
NO >> GO TO 8.

3. CHECK DISCHARGE AIR

1. Operate fan switch to set the fan speed to maximum speed.
2. Operate MODE switch.
3. Check that air outlets change according to each indicated air outlet by placing a hand in front of the outlets. Refer to [HAC-27. "REAR AUTOMATIC AIR CONDITIONING SYSTEM : System Description"](#).

Is the inspection result normal?

YES >> GO TO 4.
NO >> GO TO 8.

4. CHECK DISCHARGE AIR TEMPERATURE

1. Operate temperature control dial (driver side).
2. Check that discharge air temperature changes.

Is the inspection result normal?

YES >> GO TO 5.
NO >> GO TO 8.

5. CHECK WITH TEMPERATURE SETTING LOWERED

1. Operate temperature control dial (driver side) and lower the set temperature to 18°C (60°F).
2. Check that cool air blows from the air outlets.

Is the inspection result normal?

YES >> GO TO 6.
NO >> GO TO 8.

6. CHECK TEMPERATURE INCREASE

1. Operate temperature control dial (driver side) and raise the set temperature to 32°C (90°F).

OPERATION INSPECTION

[AUTOMATIC AIR CONDITIONING]

< BASIC INSPECTION >

2. Check that warm air blows from the air outlets.

Is the inspection result normal?

- YES >> GO TO 7.
NO >> GO TO 8.

7.CHECK AUTO MODE

1. Press AUTO switch.
2. Operate temperature control dial (driver side) to check that fan speed or air outlet changes (the air outlet or fan speed varies depending on the ambient temperature, in-vehicle temperature, set temperature, and etc.).

Is the inspection result normal?

- YES >> Inspection End.
NO >> GO TO 8.

8.CHECK SELF-DIAGNOSIS WITH CONSULT

1. Perform self-diagnosis with CONSULT.
2. Check that any DTC is detected.

Is any DTC detected?

- YES >> Refer to [HAC-47, "DTC Index"](#) and perform the appropriate diagnosis.
NO >> Refer to [HAC-147, "Diagnosis Chart By Symptom"](#) and perform the appropriate diagnosis.

Rear Air Control Operation

1.CHECK REAR BLOWER MOTOR

1. Press AUTO switch.
2. Operate fan switch.
3. Check that fan speed changes. Check operation for all fan speeds.

Is the inspection result normal?

- YES >> GO TO 2.
NO >> GO TO 7.

2.CHECK DISCHARGE AIR

1. Operate fan switch to set the fan speed to maximum speed.
2. Operate MODE switch.
3. Check that air outlets change according to each indicated air outlet by placing a hand in front of the outlets. Refer to [HAC-27, "REAR AUTOMATIC AIR CONDITIONING SYSTEM : System Description"](#).

Is the inspection result normal?

- YES >> GO TO 3.
NO >> GO TO 7.

3.CHECK DISCHARGE AIR TEMPERATURE

1. Operate temperature control switch.
2. Check that discharge air temperature changes.

Is the inspection result normal?

- YES >> GO TO 4.
NO >> GO TO 7.

4.CHECK WITH TEMPERATURE SETTING LOWERED

1. Operate temperature control switch and lower the set temperature to 18°C.
2. Check that cool air blows from the air outlets.

Is the inspection result normal?

- YES >> GO TO 5.
NO >> GO TO 7.

5.CHECK TEMPERATURE INCREASE

1. Operate temperature control switch and raise the set temperature to 32°C.
2. Check that warm air blows from the air outlets.

Is the inspection result normal?

A
B
C
D
E
F
G
H
J
K
L
M
N
O
P

HAC

OPERATION INSPECTION

< BASIC INSPECTION >

[AUTOMATIC AIR CONDITIONING]

- YES >> GO TO 6.
- NO >> GO TO 7.

6. CHECK AUTO MODE

1. Press AUTO switch.
2. Operate temperature control switch to check that fan speed or air outlet changes (the air outlet or fan speed varies depending on the ambient temperature, in-vehicle temperature (rear side), set temperature, and etc.).

Is the inspection result normal?

- YES >> Inspection End.
- NO >> GO TO 7.

7. CHECK SELF-DIAGNOSIS WITH CONSULT

1. Perform self-diagnosis with CONSULT.
2. Check that any DTC is detected.

Is any DTC detected?

- YES >> Refer to [HAC-47, "DTC Index"](#) and perform the appropriate diagnosis.
- NO >> Refer to [HAC-147, "Diagnosis Chart By Symptom"](#) and perform the appropriate diagnosis.

SYSTEM SETTING

< BASIC INSPECTION >

[AUTOMATIC AIR CONDITIONING]

SYSTEM SETTING

FRONT AUTOMATIC AIR CONDITIONING SYSTEM

FRONT AUTOMATIC AIR CONDITIONING SYSTEM : Temperature Setting Trimmer (Front)

INFOID:000000008901705

DESCRIPTION

If the temperature felt by the customer is different from the front air flow temperature controlled by the temperature setting, the A/C auto amp. control temperature can be adjusted to compensate for the temperature setting.

HOW TO SET

Ⓜ With CONSULT

Perform "TEMP SET CORRECT" of HVAC work support item.

Work support items	Display (°C)	Display (°F)
TEMP SET CORRECT	3.0	6
	2.5	5
	2.0	4
	1.5	3
	1.0	2
	0.5	1
	0 (initial status)	0 (initial status)
	-0.5	-1
	-1.0	-2
	-1.5	-3
	-2.0	-4
	-2.5	-5
	-3.0	-6

NOTE:

- When -3.0°C (-6°F) is corrected on the temperature setting set as 25.0°C (77°F) the temperature controlled by A/C auto amp. is 25.0°C (77°F) -3.0°C (-6°F) = 22.0°C (72°F) and the temperature becomes lower than the temperature setting.
- When the battery cable is disconnected from the negative terminal or when the battery voltage becomes 10 V or less, the setting of the difference between the set temperature and control temperature may be cancelled.

FRONT AUTOMATIC AIR CONDITIONING SYSTEM : Foot Position Setting Trimmer

INFOID:000000008901706

DESCRIPTION

In FOOT mode, the air blowing to DEF can change ON/OFF.

HOW TO SET

Ⓜ With CONSULT

Perform the "BLOW SET" of HVAC work support item.

Work support items	Display	Defroster door position	
		Auto control	Manual control
BLOW SET	Mode1	OPEN	CLOSE
	Mode2 (initial status)	OPEN	OPEN
	Mode3	CLOSE	OPEN
	Mode4	CLOSE	CLOSE

SYSTEM SETTING

< BASIC INSPECTION >

[AUTOMATIC AIR CONDITIONING]

NOTE:

When the battery cable is disconnected from the negative terminal or when the battery voltage becomes 10 V or less, the setting of the discharge air mix ratio in FOOT mode may be cancelled.

FRONT AUTOMATIC AIR CONDITIONING SYSTEM : Inlet Port Memory Function (FRE)

INFOID:000000008901707

DESCRIPTION

- If the ignition switch is turned to the OFF position while the intake switch is set to OFF (fresh air intake), “Perform the memory” or “Do not perform the memory” of intake switch OFF (fresh air intake) condition can be selected.
- If “Perform the memory” was set, the intake switch will be OFF (fresh air intake) when turning the ignition switch to the ON position again.
- If “Do not perform the memory” was set, the air inlets will be controlled automatically when turning the ignition switch to the ON position again.

HOW TO SET

Ⓟ With CONSULT

Perform the “FRE MEMORY SET” of HVAC work support item.

Work support items	Display	Setting
FRE MEMORY SET	WITHOUT	Perform the memory of manual FRE
	WITH (initial status)	Do not perform the memory of manual FRE (auto control)

NOTE:

When the battery cable is disconnected from the negative terminal or when the battery voltage becomes 10 V or less, the setting of the FRE memory function may be cancelled.

FRONT AUTOMATIC AIR CONDITIONING SYSTEM : Inlet Port Memory Function (REC)

INFOID:000000008901708

DESCRIPTION

- If the ignition switch is turned to the OFF position while the intake switch is set to ON (recirculation), “Perform the memory” or “Do not perform the memory” of intake switch ON (recirculation) condition can be selected.
- If “Perform the memory” was set, the intake switch will be ON (recirculation) when turning the ignition switch to the ON position again.
- If “Do not perform the memory” was set, the air inlets will be controlled automatically when turning the ignition switch to the ON position again.

HOW TO SET

Ⓟ With CONSULT

Perform the “REC MEMORY SET” of HVAC work support item.

Work support items	Display	Setting
REC MEMORY SET	WITHOUT (initial status)	Perform the memory of manual REC
	WITH	Do not perform the memory of manual REC (auto control)

NOTE:

When the battery cable is disconnected from the negative terminal or when the battery voltage becomes 10 V or less, the setting of the REC memory function may be cancelled.

REAR AUTOMATIC AIR CONDITIONING SYSTEM

REAR AUTOMATIC AIR CONDITIONING SYSTEM : Temperature Setting Trimmer (Rear)

INFOID:000000008901709

DESCRIPTION

SYSTEM SETTING

< BASIC INSPECTION >

[AUTOMATIC AIR CONDITIONING]

If the temperature felt by the customer is different from the rear air flow temperature controlled by the temperature setting, the A/C auto amp. control temperature can be adjusted to compensate for the temperature setting.

HOW TO SET

Ⓜ With CONSULT

Perform "REAR TEMP SET CORRECT" of HVAC work support item.

Work support items	Display (°C)	Display (°F)
REAR TEMP SET CORRECT	3.0	6
	2.5	5
	2.0	4
	1.5	3
	1.0	2
	0.5	1
	0 (initial status)	0 (initial status)
	-0.5	-1
	-1.0	-2
	-1.5	-3
	-2.0	-4
	-2.5	-5
	-3.0	-6

NOTE:

- When -3.0°C (-6°F) is corrected on the temperature setting set as 25.0°C (77°F) the temperature controlled by A/C auto amp. is 25.0°C (77°F) -3.0°C (-6°F) = 22.0°C (72°F) and the temperature becomes lower than the temperature setting.
- When the battery cable is disconnected from the negative terminal or when the battery voltage becomes 10 V or less, the setting of the difference between the set temperature and control temperature may be cancelled.

DTC/CIRCUIT DIAGNOSIS

U1000 CAN COMM CIRCUIT

Description

INFOID:000000008901727

CAN (Controller Area Network) is a serial communication system for real time application. It is an on-vehicle multiplex communication system with high data communication speed and excellent error detection ability. Many electronic control units are equipped onto vehicles, and each control unit shares information and links with other control units during operation (not independent). In CAN communication, control units are connected with two communication lines (CAN-H line, CAN-L line) allowing a high rate of information transmission with less wiring. Each control unit transmits/receives data but selectively reads required data only. Refer to [LAN-36, "CAN COMMUNICATION SYSTEM : CAN Communication Signal Chart"](#).

DTC Logic

INFOID:000000008901728

DTC DETECTION LOGIC

DTC	Items (CONSULT screen terms)	DTC detection condition	Possible cause
U1000	CAN COMM CIRCUIT	When A/C auto amp. is not transmitting or receiving CAN communication signal for 2 or more seconds.	CAN communication system

DTC CONFIRMATION PROCEDURE

1. PERFORM SELF-DIAGNOSIS

④ With CONSULT

1. Turn ignition switch ON and wait for 2 seconds or more.
2. Using CONSULT, perform "SELF-DIAGNOSIS RESULTS" of HVAC.
3. Check if any DTC No. is displayed in the self-diagnosis results.

Is DTC detected?

- YES >> Refer to [HAC-82, "Diagnosis Procedure"](#).
 NO >> Refer to [GI-49, "Intermittent Incident"](#).

Diagnosis Procedure

INFOID:000000008901729

1. CHECK CAN COMMUNICATION SYSTEM

Check CAN communication system. Refer to [LAN-20, "Trouble Diagnosis Flow Chart"](#).

>> Inspection End.

U1010 CONTROL UNIT (CAN)

[AUTOMATIC AIR CONDITIONING]

< DTC/CIRCUIT DIAGNOSIS >

U1010 CONTROL UNIT (CAN)

Description

INFOID:000000008901730

Initial diagnosis of A/C auto amp.

DTC Logic

INFOID:000000008901731

DTC DETECTION LOGIC

DTC	Items (CONSULT screen terms)	DTC detection condition	Possible cause
U1010	CONTROL UNIT (CAN)	When detecting error during the initial diagnosis of CAN controller of A/C auto amp.	A/C auto amp.

DTC CONFIRMATION PROCEDURE

1. PERFORM SELF-DIAGNOSIS

Ⓜ With CONSULT

1. Turn ignition switch ON.
2. Using CONSULT, perform "SELF-DIAGNOSIS RESULTS" of HVAC.
3. Check if any DTC No. is displayed in the self-diagnosis results.

Is DTC detected?

- YES >> Refer to [HAC-83. "Diagnosis Procedure"](#).
NO >> Inspection End.

Diagnosis Procedure

INFOID:000000008901732

1. REPLACE A/C AUTO AMP.

Replace A/C auto amp. Refer to [HAC-156. "Removal and Installation"](#).

>> Inspection End.

A
B
C
D
E
F
G
H
HAC
J
K
L
M
N
O
P

B2578, B2579 IN-VEHICLE SENSOR

< DTC/CIRCUIT DIAGNOSIS >

[AUTOMATIC AIR CONDITIONING]

B2578, B2579 IN-VEHICLE SENSOR

DTC Logic

INFOID:000000008901733

DTC DETECTION LOGIC

NOTE:

- If DTC is displayed along with DTC U1000, first perform the trouble diagnosis for DTC U1000. Refer to [HAC-82, "DTC Logic"](#).
- If DTC is displayed along with DTC U1010, first perform the trouble diagnosis for DTC U1010. Refer to [HAC-83, "DTC Logic"](#).

DTC	Items (CONSULT screen terms)	DTC detection condition	Possible cause
B2578	IN-VEHICLE SENSOR	The in-vehicle sensor recognition temperature is too high.	<ul style="list-style-type: none"> • In-vehicle sensor • A/C auto amp. • Harness or connectors (The sensor circuit is open or shorted.)
B2579		The in-vehicle sensor recognition temperature is too low.	

DTC CONFIRMATION PROCEDURE

1. PERFORM DTC CONFIRMATION PROCEDURE

Ⓟ With CONSULT

1. Turn ignition switch ON.
2. Using CONSULT, perform "SELF-DIAGNOSIS RESULTS" of HVAC.
3. Check if any DTC No. is displayed in the self-diagnosis results.

Is DTC detected?

- YES >> Refer to [HAC-84, "Diagnosis Procedure"](#).
 NO >> Inspection End.

Diagnosis Procedure

INFOID:000000008901734

Regarding Wiring Diagram information, refer to [HAC-50, "Wiring Diagram"](#).

1. CHECK IN-VEHICLE SENSOR POWER SUPPLY

1. Turn ignition switch OFF.
2. Disconnect in-vehicle sensor connector.
3. Turn ignition switch ON.
4. Check voltage between in-vehicle sensor harness connector and ground.

+		-	Voltage (Approx.)
In-vehicle sensor			
Connector	Terminal		
M102	1	Ground	5 V

Is the inspection result normal?

- YES >> GO TO 2.
 NO >> GO TO 4.

2. CHECK IN-VEHICLE SENSOR GROUND CIRCUIT

1. Turn ignition switch OFF.
2. Check continuity between front in-vehicle sensor harness connector and ground.

B2578, B2579 IN-VEHICLE SENSOR

[AUTOMATIC AIR CONDITIONING]

< DTC/CIRCUIT DIAGNOSIS >

In-vehicle sensor		—	Continuity
Connector	Terminal		
M102	2	Ground	Yes

Is the inspection result normal?

YES >> GO TO 3.

NO >> Repair harness or connector.

3.CHECK IN-VEHICLE SENSOR

Check in-vehicle sensor. Refer to [HAC-85, "Component Inspection"](#).

Is the inspection result normal?

YES >> Replace A/C auto amp. Refer to [HAC-156, "Removal and Installation"](#).

NO >> Replace in-vehicle sensor. Refer to [HAC-158, "Removal and Installation"](#).

4.CHECK IN-VEHICLE SENSOR POWER SUPPLY CIRCUIT FOR OPEN

1. Turn ignition switch OFF.
2. Disconnect A/C auto amp. connector.
3. Check continuity between in-vehicle sensor harness connector and A/C auto amp. harness connector.

In-vehicle sensor		A/C auto amp.		Continuity
Connector	Terminal	Connector	Terminal	
M102	1	M50	27	Yes

Is the inspection result normal?

YES >> GO TO 5.

NO >> Repair harness or connector.

5.CHECK IN-VEHICLE SENSOR POWER SUPPLY CIRCUIT FOR GROUND SHORT

Check continuity between in-vehicle sensor harness connector and ground.

In-vehicle sensor		—	Continuity
Connector	Terminal		
M102	1	Ground	No

Is the inspection result normal?

YES >> GO TO 6.

NO >> Repair harness or connector.

6.CHECK IN-VEHICLE SENSOR POWER SUPPLY CIRCUIT FOR POWER SHORT

1. Turn ignition switch ON.
2. Check voltage between in-vehicle sensor harness connector and ground.

+		-	Voltage (Approx.)
In-vehicle sensor			
Connector	Terminal		
M102	1	Ground	0 V

Is the inspection result normal?

YES >> Replace A/C auto amp. Refer to [HAC-156, "Removal and Installation"](#).

NO >> Repair harness or connector.

Component Inspection

INFOID:000000008901735

1.CHECK IN-VEHICLE SENSOR

1. Turn ignition switch OFF.
2. Disconnect in-vehicle sensor connector.

B2578, B2579 IN-VEHICLE SENSOR

< DTC/CIRCUIT DIAGNOSIS >

[AUTOMATIC AIR CONDITIONING]

3. Check resistance between in-vehicle sensor terminals.

Terminal		Condition	Resistance: kΩ
		Temperature: °C (°F)	
1	2	-15 (5)	12.73
		-10 (14)	9.92
		-5 (23)	7.80
		0 (32)	6.19
		5 (41)	4.95
		10 (50)	3.99
		15 (59)	3.24
		20 (68)	2.65
		25 (77)	2.19
		30 (86)	1.81
		35 (95)	1.51
		40 (104)	1.27
		45 (113)	1.07

Is the inspection result normal?

YES >> Inspection End.

NO >> Replace in-vehicle sensor. Refer to [HAC-158. "Removal and Installation"](#).

B257B, B257C AMBIENT SENSOR

< DTC/CIRCUIT DIAGNOSIS >

[AUTOMATIC AIR CONDITIONING]

B257B, B257C AMBIENT SENSOR

DTC Logic

INFOID:000000008901736

DTC DETECTION LOGIC

NOTE:

- If DTC is displayed along with DTC U1000, first perform the trouble diagnosis for DTC U1000. Refer to [HAC-82, "DTC Logic"](#).
- If DTC is displayed along with DTC U1010, first perform the trouble diagnosis for DTC U1010. [HAC-83, "DTC Logic"](#).

DTC	Items (CONSULT screen terms)	DTC detection condition	Possible cause
B257B	AMBIENT SENSOR	The ambient sensor recognition temperature is too high.	<ul style="list-style-type: none"> • Ambient sensor • A/C auto amp. • Harness or connectors (The sensor circuit is open or shorted.)
B257C		The ambient sensor recognition temperature is too low.	

DTC CONFIRMATION PROCEDURE

1. PERFORM DTC CONFIRMATION PROCEDURE

Ⓜ With CONSULT

1. Turn ignition switch ON.
2. Using CONSULT, perform "SELF-DIAGNOSIS RESULTS" of HVAC.
3. Check if any DTC No. is displayed in the self-diagnosis results.

Is DTC detected?

- YES >> Refer to [HAC-87, "Diagnosis Procedure"](#).
 NO >> Inspection End.

HAC

Diagnosis Procedure

INFOID:000000008901737

Regarding Wiring Diagram information, refer to [HAC-50, "Wiring Diagram"](#).

1. CHECK AMBIENT SENSOR POWER SUPPLY

1. Turn ignition switch OFF.
2. Disconnect ambient sensor connector.
3. Turn ignition switch ON.
4. Check voltage between ambient sensor harness connector and ground.

+		-	Voltage (Approx.)
Ambient sensor			
Connector	Terminal		
E206	1	Ground	5 V

Is the inspection result normal?

- YES >> GO TO 2.
 NO >> GO TO 4.

2. CHECK AMBIENT SENSOR GROUND CIRCUIT

1. Turn ignition switch OFF.
2. Check continuity between ambient sensor harness connector and ground.

B257B, B257C AMBIENT SENSOR

< DTC/CIRCUIT DIAGNOSIS >

[AUTOMATIC AIR CONDITIONING]

Ambient sensor		—	Continuity
Connector	Terminal		
E206	2	Ground	Yes

Is the inspection result normal?

YES >> GO TO 3.

NO >> Repair harness or connector.

3.CHECK AMBIENT SENSOR

Check ambient sensor. Refer to [HAC-88, "Component Inspection"](#).

Is the inspection result normal?

YES >> Replace A/C auto amp. Refer to [HAC-156, "Removal and Installation"](#).

NO >> Replace ambient sensor. Refer to [HAC-157, "Removal and Installation"](#).

4.CHECK AMBIENT SENSOR POWER SUPPLY CIRCUIT FOR OPEN

1. Turn ignition switch OFF.
2. Disconnect A/C auto amp.connector.
3. Check continuity between ambient sensor harness connector and A/C auto amp. harness connector.

Ambient sensor		A/C auto amp.		Continuity
Connector	Terminal	Connector	Terminal	
E206	1	M50	7	Yes

Is the inspection result normal?

YES >> GO TO 5.

NO >> Repair harness or connector.

5.CHECK AMBIENT SENSOR POWER SUPPLY CIRCUIT FOR GROUND SHORT

Check continuity between ambient sensor harness connector and ground.

Ambient sensor		—	Continuity
Connector	Terminal		
E206	1	Ground	No

Is the inspection result normal?

YES >> GO TO 6.

NO >> Repair harness or connector.

6.CHECK AMBIENT SENSOR POWER SUPPLY CIRCUIT FOR POWER SHORT

1. Turn ignition switch ON.
2. Check voltage between ambient sensor harness connector and ground.

+		-	Voltage (Approx.)
Ambient sensor			
Connector	Terminal		
E206	1	Ground	0 V

Is the inspection result normal?

YES >> Replace A/C auto amp. Refer to [HAC-156, "Removal and Installation"](#).

NO >> Repair harness or connector.

Component Inspection

INFOID:000000008901738

1.CHECK AMBIENT SENSOR

1. Turn ignition switch OFF.
2. Disconnect ambient sensor connector.

B257B, B257C AMBIENT SENSOR

< DTC/CIRCUIT DIAGNOSIS >

[AUTOMATIC AIR CONDITIONING]

3. Check resistance between ambient sensor terminals.

Terminal		Condition	Resistance: kΩ
		Temperature: °C (°F)	
1	2	-15 (5)	12.73
		-10 (14)	9.92
		-5 (23)	7.80
		0 (32)	6.19
		5 (41)	4.95
		10 (50)	3.99
		15 (59)	3.24
		20 (68)	2.65
		25 (77)	2.19
		30 (86)	1.81
		35 (95)	1.51
		40 (104)	1.27
		45 (113)	1.07

Is the inspection result normal?

YES >> Inspection End.

NO >> Replace ambient sensor. Refer to [HAC-157. "Removal and Installation"](#).

A
B
C
D
E
F
G
H
J
K
L
M
N
O
P

HAC

B2581, B2582 INTAKE SENSOR

< DTC/CIRCUIT DIAGNOSIS >

[AUTOMATIC AIR CONDITIONING]

B2581, B2582 INTAKE SENSOR

DTC Logic

INFOID:000000008901739

DTC DETECTION LOGIC

NOTE:

- If DTC is displayed along with DTC U1000, first perform the trouble diagnosis for DTC U1000. Refer to [HAC-82, "DTC Logic"](#).
- If DTC is displayed along with DTC U1010, first perform the trouble diagnosis for DTC U1010. [HAC-83, "DTC Logic"](#).

DTC	Items (CONSULT screen terms)	DTC detection condition	Possible cause
B2581	INTAKE SENSOR	The intake sensor recognition temperature is too high.	<ul style="list-style-type: none">• Intake sensor• A/C auto amp.• Harness or connectors (The sensor circuit is open or shorted.)
B2582		The intake sensor recognition temperature is too low.	

DTC CONFIRMATION PROCEDURE

1. PERFORM DTC CONFIRMATION PROCEDURE

Ⓟ With CONSULT

1. Turn ignition switch ON.
2. Using CONSULT, perform "SELF-DIAGNOSIS RESULTS" of HVAC.
3. Check if any DTC No. is displayed in the self-diagnosis results.

Is DTC detected?

- YES >> Refer to [HAC-90, "Diagnosis Procedure"](#).
NO >> Inspection End.

Diagnosis Procedure

INFOID:000000008901740

Regarding Wiring Diagram information, refer to [HAC-50, "Wiring Diagram"](#).

1. CHECK INTAKE SENSOR POWER SUPPLY

1. Turn ignition switch OFF.
2. Disconnect intake sensor connector.
3. Turn ignition switch ON.
4. Check voltage between intake sensor harness connector and ground.

+		-	Voltage (Approx.)
Intake sensor			
Connector	Terminal		
M103	1	Ground	5 V

Is the inspection result normal?

- YES >> GO TO 2.
NO >> GO TO 4.

2. CHECK INTAKE SENSOR GROUND CIRCUIT

1. Turn ignition switch OFF.
2. Check continuity between intake sensor harness connector and ground.

B2581, B2582 INTAKE SENSOR

< DTC/CIRCUIT DIAGNOSIS >

[AUTOMATIC AIR CONDITIONING]

Intake sensor		—	Continuity
Connector	Terminal		
M103	2	Ground	Yes

Is the inspection result normal?

YES >> GO TO 3.

NO >> Repair harness or connector.

3.CHECK INTAKE SENSOR

Check intake sensor. Refer to [HAC-91, "Component Inspection"](#).

Is the inspection result normal?

YES >> Replace A/C auto amp. Refer to [HAC-156, "Removal and Installation"](#).

NO >> Replace intake sensor. Refer to [HAC-160, "Removal and Installation"](#).

4.CHECK INTAKE SENSOR POWER SUPPLY CIRCUIT FOR OPEN

1. Turn ignition switch OFF.
2. Disconnect A/C auto amp. connector.
3. Check continuity between intake sensor harness connector and A/C auto amp. harness connector.

Intake sensor		A/C auto amp.		Continuity
Connector	Terminal	Connector	Terminal	
M103	1	M50	28	Yes

Is the inspection result normal?

YES >> GO TO 5.

NO >> Repair harness or connector.

5.CHECK INTAKE SENSOR POWER SUPPLY CIRCUIT FOR GROUND SHORT

Check continuity between intake sensor harness connector and ground.

Intake sensor		—	Continuity
Connector	Terminal		
M103	1	Ground	No

Is the inspection result normal?

YES >> GO TO 6.

NO >> Repair harness or connector.

6.CHECK INTAKE SENSOR POWER SUPPLY CIRCUIT FOR POWER SHORT

1. Turn ignition switch ON.
2. Check voltage between intake sensor harness connector and ground.

+		-	Voltage (Approx.)
Intake sensor			
Connector	Terminal		
M103	1	Ground	0 V

Is the inspection result normal?

YES >> Replace A/C auto amp. Refer to [HAC-156, "Removal and Installation"](#).

NO >> Repair harness or connector.

Component Inspection

INFOID:000000008901741

1.CHECK INTAKE SENSOR

1. Turn ignition switch OFF.
2. Disconnect intake sensor connector.

B2581, B2582 INTAKE SENSOR

< DTC/CIRCUIT DIAGNOSIS >

[AUTOMATIC AIR CONDITIONING]

3. Check resistance between intake sensor terminals.

Terminal		Condition	Resistance: kΩ
		Temperature: °C (°F)	
1	2	-15 (5)	17.73
		-10 (14)	13.46
		-5 (23)	10.33
		0 (32)	8.00
		5 (41)	6.25
		10 (50)	4.93
		15 (59)	3.92
		20 (68)	3.14
		25 (77)	2.54
		30 (86)	2.06
		35 (95)	1.69
		40 (104)	1.39
		45 (113)	1.15

Is the inspection result normal?

YES >> Inspection End.

NO >> Replace intake sensor. Refer to [HAC-160. "Removal and Installation"](#).

B2630, B2631 SUNLOAD SENSOR

< DTC/CIRCUIT DIAGNOSIS >

[AUTOMATIC AIR CONDITIONING]

B2630, B2631 SUNLOAD SENSOR

DTC Logic

INFOID:000000008901744

DTC DETECTION LOGIC

NOTE:

- If DTC is displayed along with DTC U1000 or U1010, first diagnose the DTC U1000 or U1010. Refer to [HAC-82. "DTC Logic"](#) or [HAC-83. "DTC Logic"](#).
- Sunload sensor may register a malfunction when indoors, at dusk, or at other times when light is insufficient. When performing the diagnosis indoors, light the sunload sensor with a lamp (60W or more).

DTC	Items (CONSULT screen terms)	Diagnostic item is detected when...	Possible cause
B2630	SUNLOAD SEN (SHORT)	Detected calorie at sunload sensor 1395 w/m ² (1200 kcal/m ² ·h) or more	<ul style="list-style-type: none"> • Sunload sensor • A/C auto amp. • Harness and connector
B2631	SUNLOAD SEN (OPEN)	Detected calorie at sunload sensor 0 w/m ² (0 kcal/m ² ·h)	(Sunload sensor circuit is open, or there is a short in the circuit)

DTC CONFIRMATION PROCEDURE

1. CHECK WITH SELF-DIAGNOSIS FUNCTION OF CONSULT

1. Using CONSULT, perform "SELF-DIAGNOSIS RESULTS" of HVAC.
2. Check if any DTC No. is displayed in the self-diagnosis results.

NOTE:

- If DTC is displayed along with DTC U1000 or U1010, first diagnose the DTC U1000 or U1010. Refer to [HAC-82. "DTC Logic"](#) or [HAC-83. "DTC Logic"](#).
- Sunload sensor may register a malfunction when indoors, at dusk, or at other times when light is insufficient. When performing the diagnosis indoors, light the sunload sensor with a lamp (60W or more).

Is DTC No. "B2630" or "B2631" displayed?

- YES >> Perform trouble diagnosis for the sunload sensor. Refer to [HAC-93. "Diagnosis Procedure"](#).
- NO >> Inspection End.

Diagnosis Procedure

INFOID:000000008901745

Regarding Wiring Diagram information, refer to [HAC-50. "Wiring Diagram"](#).

1. CHECK SUNLOAD SENSOR POWER SUPPLY

1. Disconnect sunload sensor connector.
2. Turn ignition switch ON.
3. Check voltage between sunload sensor harness connector M101 terminal 1 and ground.

+		-	Voltage (Approx.)
Sunload sensor			
Connector	Terminal		
M101	1	Ground	5 V

Is the inspection result normal?

- YES >> GO TO 2.
- NO >> GO TO 4.

2. CHECK CONTINUITY BETWEEN SUNLOAD SENSOR AND A/C AUTO AMP.

1. Turn ignition switch OFF.
2. Disconnect A/C auto amp. connector.

B2630, B2631 SUNLOAD SENSOR

[AUTOMATIC AIR CONDITIONING]

< DTC/CIRCUIT DIAGNOSIS >

3. Check continuity between sunload sensor harness connector M101 terminal 2 and A/C auto amp. harness connector M50 terminal 26.

Sunload sensor		A/C auto amp.		Continuity
Connector	Terminal	Connector	Terminal	
M101	2	M50	26	Yes

Is the inspection result normal?

YES >> GO TO 3.

NO >> Repair harness or connector.

3.CHECK SUNLOAD SENSOR

1. Reconnect sunload sensor connector and A/C auto amp. connector.
2. Check sunload sensor. Refer to [HAC-94. "Component Inspection"](#).

Is the inspection result normal?

YES >> Replace A/C auto amp. Refer to [HAC-156. "Removal and Installation"](#).

NO >> Replace sunload sensor. Refer to [HAC-159. "Removal and Installation"](#).

4.CHECK CONTINUITY BETWEEN SUNLOAD SENSOR AND A/C AUTO AMP.

1. Turn ignition switch OFF.
2. Disconnect A/C auto amp. connector.
3. Check continuity between sunload sensor harness connector M101 terminal 1 and A/C auto amp. harness connector M50 terminal 9.

Sunload sensor		A/C auto amp.		Continuity
Connector	Terminal	Connector	Terminal	
M101	1	M50	9	Yes

4. Check continuity between sunload sensor harness connector M101 terminal 1 and ground.

Sunload sensor		—	Continuity
Connector	Terminal		
M101	1	Ground	No

Is the inspection result normal?

YES >> Replace A/C auto amp. Refer to [HAC-156. "Removal and Installation"](#).

NO >> Repair harness or connector.

Component Inspection

INFOID:000000008901746

1.CHECK SUNLOAD SENSOR

1. Turn ignition switch ON.
2. Check voltage between A/C auto amp. harness connector and ground.

(+)		(-)	
A/C auto amp.		—	
Connector	Terminal		
M50	9	Ground	

B2630, B2631 SUNLOAD SENSOR

< DTC/CIRCUIT DIAGNOSIS >

[AUTOMATIC AIR CONDITIONING]

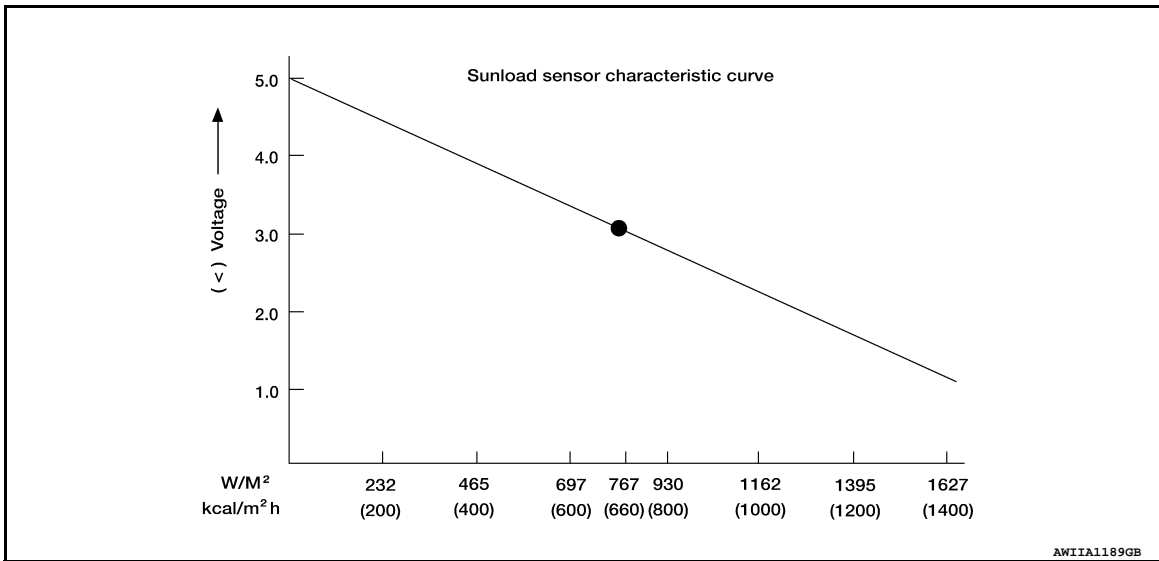

NOTE:

Select a place in direct sunlight when checking sunload sensor.

Is the inspection result normal?

YES >> Inspection End.

NO >> Replace sunload sensor. Refer to [HAC-159, "Removal and Installation"](#).

A
B
C
D
E
F
G
H
J
K
L
M
N
O
P

HAC

B2632, B2633 AIR MIX DOOR MOTOR (DRIVER SIDE)

< DTC/CIRCUIT DIAGNOSIS >

[AUTOMATIC AIR CONDITIONING]

B2632, B2633 AIR MIX DOOR MOTOR (DRIVER SIDE)

DTC Logic

INFOID:000000008901747

DTC DETECTION LOGIC

DTC	Items (CONSULT screen terms)	DTC detection condition	Possible cause
B2632	DR AIR MIX DOOR MOT	Air mix door motor (driver side) PBR position 95% or more	<ul style="list-style-type: none"> Air mix door motor (driver side) (PBR internal circuit is open or shorted) Air mix door motor (driver side) installation condition A/C auto amp. Harness and connector (LIN communication line is open or shorted)
B2633		Air mix door motor (driver side) PBR position 5% or less	

DTC CONFIRMATION PROCEDURE

1. PERFORM DTC CONFIRMATION PROCEDURE

④ With CONSULT

- Turn ignition switch ON.
- Using CONSULT, perform "SELF-DIAGNOSIS RESULTS" of HVAC.
- Check if any DTC No. is displayed in the self-diagnosis results.

Is DTC detected?

- YES >> Refer to [HAC-96. "Diagnosis Procedure"](#).
 NO >> Inspection End.

Diagnosis Procedure

INFOID:000000008901748

Regarding Wiring Diagram information, refer to [HAC-50. "Wiring Diagram"](#).

1. CHECK AIR MIX DOOR MOTOR (DRIVER SIDE) COMMUNICATION SIGNAL

- Turn ignition switch ON.
- Check output waveform between air mix door motor (driver side) harness connector and ground with the oscilloscope.

+		-	Output waveform
Air mix door motor (driver side)	Connector		
	Terminal		
M130	2	Ground	

Is the inspection result normal?

- YES >> GO TO 2.
 NO >> GO TO 3.

2. CHECK INSTALLATION OF AIR MIX DOOR MOTOR (DRIVER SIDE)

Check air mix door motor (driver side) is properly installed. Refer to [HAC-162. "Exploded View"](#).

B2632, B2633 AIR MIX DOOR MOTOR (DRIVER SIDE)

< DTC/CIRCUIT DIAGNOSIS >

[AUTOMATIC AIR CONDITIONING]

Is the inspection result normal?

- YES >> Replace air mix door motor (driver side). Refer to [HAC-164, "AIR MIX DOOR MOTOR : Removal and Installation - Air Mix Door Motor \(Driver Side\)"](#).
NO >> Repair or replace malfunctioning part.

3. CHECK AIR MIX DOOR MOTOR (DRIVER SIDE) COMMUNICATION SIGNAL CIRCUIT

1. Turn ignition switch OFF.
2. Disconnect air mix door motor (driver side) and A/C auto amp. connector.
3. Check continuity between air mix door motor (driver side) harness connector and A/C auto amp. harness connector.

Air mix door motor (driver side)		A/C auto amp.		Continuity
Connector	Terminal	Connector	Terminal	
M130	2	M50	16	Yes

Is the inspection result normal?

- YES >> Replace A/C auto amp. Refer to [HAC-156, "Removal and Installation"](#).
NO >> Repair harness or connector.

A
B
C
D
E
F
G
H
J
K
L
M
N
O
P

HAC

B2634, B2635 AIR MIX DOOR MOTOR (PASSENGER SIDE)

< DTC/CIRCUIT DIAGNOSIS >

[AUTOMATIC AIR CONDITIONING]

B2634, B2635 AIR MIX DOOR MOTOR (PASSENGER SIDE)

DTC Logic

INFOID:000000008901749

DTC DETECTION LOGIC

DTC	Items (CONSULT screen terms)	DTC detection condition	Possible cause
B2634	PASS AIR MIX DOOR MOT	Air mix door motor (passenger side) PBR position 95% or more	<ul style="list-style-type: none"> Air mix door motor (passenger side) (PBR internal circuit is open or shorted) Air mix door motor (passenger side) installation condition A/C auto amp. Harness and connector (LIN communication line is open or shorted)
B2635		Air mix door motor (passenger side) PBR position 5% or less	

DTC CONFIRMATION PROCEDURE

1. PERFORM DTC CONFIRMATION PROCEDURE

④ With CONSULT

- Turn ignition switch ON.
- Using CONSULT, perform "SELF-DIAGNOSIS RESULTS" of HVAC.
- Check if any DTC No. is displayed in the self-diagnosis results.

Is DTC detected?

- YES >> Refer to [HAC-98. "Diagnosis Procedure"](#).
 NO >> Inspection End.

Diagnosis Procedure

INFOID:000000008901750

Regarding Wiring Diagram information, refer to [HAC-50. "Wiring Diagram"](#).

1. CHECK AIR MIX DOOR MOTOR (PASSENGER SIDE) COMMUNICATION SIGNAL

- Turn ignition switch ON.
- Check output waveform between front air mix door motor RH harness connector and ground with the oscilloscope.

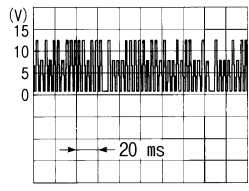
+		-	Output waveform
Connector	Terminal		
M131	2	Ground	 <p style="text-align: right;">SJIA1453J</p>

Is the inspection result normal?

- YES >> GO TO 2.
 NO >> GO TO 3.

2. CHECK INSTALLATION OF AIR MIX DOOR MOTOR (PASSENGER SIDE)

Check air mix door motor (passenger side) is properly installed. Refer to [HAC-162. "Exploded View"](#).

B2634, B2635 AIR MIX DOOR MOTOR (PASSENGER SIDE)

< DTC/CIRCUIT DIAGNOSIS >

[AUTOMATIC AIR CONDITIONING]

Is the inspection result normal?

- YES >> Replace air mix door motor (passenger side). Refer to [HAC-164, "AIR MIX DOOR MOTOR : Removal and Installation - Air Mix Door Motor \(Passenger Side\)"](#).
- NO >> Repair or replace malfunctioning part.

3. CHECK AIR MIX DOOR MOTOR (PASSENGER SIDE) COMMUNICATION SIGNAL CIRCUIT

1. Turn ignition switch OFF.
2. Disconnect air mix door motor (passenger side) and A/C auto amp. connector.
3. Check continuity between air mix door motor (passenger side) harness connector and A/C auto amp. harness connector.

Air mix door motor (passenger side)		A/C auto amp.		Continuity
Connector	Terminal	Connector	Terminal	
M131	2	M50	16	Yes

Is the inspection result normal?

- YES >> Replace A/C auto amp. Refer to [HAC-156, "Removal and Installation"](#).
- NO >> Repair harness or connector.

A
B
C
D
E
F
G
H
J
K
L
M
N
O
P

HAC

B2636, B2637, B2638, B2639, B2654 MODE DOOR MOTOR (FRONT)

< DTC/CIRCUIT DIAGNOSIS >

[AUTOMATIC AIR CONDITIONING]

B2636, B2637, B2638, B2639, B2654 MODE DOOR MOTOR (FRONT)

DTC Logic

INFOID:000000008901751

DTC DETECTION LOGIC

DTC	Items (CONSULT screen terms)	DTC detection condition	Possible cause
B2636	DR VENT DOOR FAIL	When the malfunctioning door position is detected at VENT position	<ul style="list-style-type: none"> Mode door motor (front) (PBR internal circuit is open or shorted) Mode door motor (front) control linkage installation condition A/C auto amp. Harness and connector (LIN communication line is open or shorted)
B2637	DR B/L DOOR FAIL	When the malfunctioning door position is detected at B/L position	
B2638	DR D/F1 DOOR FAIL	When the malfunctioning door position is detected at FOOT position	
B2639	DR DEF DOOR FAIL	When the malfunctioning door position is detected at DEF position	
B2654	D/F2 VENT DOOR FAIL	When the malfunctioning door position is detected at D/F position	

DTC CONFIRMATION PROCEDURE

1. PERFORM DTC CONFIRMATION PROCEDURE

Ⓜ With CONSULT

- Turn ignition switch ON.
- Using CONSULT, perform "SELF-DIAGNOSIS RESULTS" of HVAC.
- Check if any DTC No. is displayed in the self-diagnosis results.

Is DTC detected?

- YES >> Refer to [HAC-100, "Diagnosis Procedure"](#).
 NO >> Inspection End.

Diagnosis Procedure

INFOID:000000008901752

Regarding Wiring Diagram information, refer to [HAC-50, "Wiring Diagram"](#).

1. CHECK MODE DOOR MOTOR (FRONT) COMMUNICATION SIGNAL

- Turn ignition switch ON.
- Check output waveform between mode door motor (front) harness connector and ground with the oscilloscope.

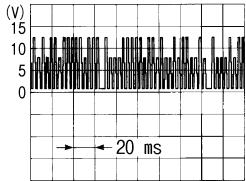
+		-	Output waveform
Mode door motor (front)			
Connector	Terminal		
M129	2	Ground	 <p style="text-align: right;">SJIA1453J</p>

Is the inspection result normal?

- YES >> GO TO 2.
 NO >> GO TO 3.

B2636, B2637, B2638, B2639, B2654 MODE DOOR MOTOR (FRONT)

[AUTOMATIC AIR CONDITIONING]

< DTC/CIRCUIT DIAGNOSIS >

2. CHECK INSTALLATION OF MODE DOOR MOTOR (FRONT)

Check mode door motor (front) is properly installed. Refer to [HAC-162, "Exploded View"](#).

Is the inspection result normal?

YES >> Replace mode door motor (front). Refer to [HAC-163, "MODE DOOR MOTOR : Removal and Installation - Mode Door Motor \(Front\)"](#).

NO >> Repair or replace malfunctioning part.

3. CHECK MODE DOOR MOTOR (FRONT) COMMUNICATION SIGNAL CIRCUIT

1. Turn ignition switch OFF.
2. Disconnect mode door motor (front) and A/C auto amp. connector.
3. Check continuity between mode door motor (front) harness connector and A/C auto amp. harness connector.

Mode door motor (front)		A/C auto amp.		Continuity
Connector	Terminal	Connector	Terminal	
M129	2	M50	16	Yes

Is the inspection result normal?

YES >> Replace A/C auto amp. Refer to [HAC-156, "Removal and Installation"](#).

NO >> Repair harness or connector.

A
B
C
D
E
F
G
H
J
K
L
M
N
O
P

HAC

B263D, B263E, B263F INTAKE DOOR MOTOR

< DTC/CIRCUIT DIAGNOSIS >

[AUTOMATIC AIR CONDITIONING]

B263D, B263E, B263F INTAKE DOOR MOTOR

DTC Logic

INFOID:000000008901753

DTC DETECTION LOGIC

DTC	Items (CONSULT screen terms)	DTC detection condition	Possible cause
B263D	FRE DOOR FAIL	When the malfunctioning intake door position is detected at FRE position	<ul style="list-style-type: none"> Intake door motor (PBR internal circuit is open or shorted) A/C auto amp. Harness and connector (LIN communication line is open or shorted)
B263E	20P FRE DOOR FAIL	When the malfunctioning intake door position is detected at 20% FRE position	
B263F	REC DOOR FAIL	When the malfunctioning intake door position is detected at REC position	

DTC CONFIRMATION PROCEDURE

1. PERFORM DTC CONFIRMATION PROCEDURE

Ⓟ With CONSULT

- Turn ignition switch ON.
- Using CONSULT, perform "SELF-DIAGNOSIS RESULTS" of HVAC.
- Check if any DTC No. is displayed in the self-diagnosis results.

Is DTC detected?

- YES >> Refer to [HAC-102, "Diagnosis Procedure"](#).
 NO >> Inspection End.

Diagnosis Procedure

INFOID:000000008901754

Regarding Wiring Diagram information, refer to [HAC-50, "Wiring Diagram"](#).

1. CHECK INTAKE DOOR MOTOR COMMUNICATION SIGNAL

- Turn ignition switch ON.
- Check output waveform between intake door motor harness connector and ground with the oscilloscope.

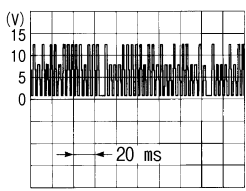
+		-	Output waveform
Intake door motor			
Connector	Terminal		
M128	2	Ground	 <p style="text-align: right;">SJIA1453J</p>

Is the inspection result normal?

- YES >> GO TO 2.
 NO >> GO TO 3.

2. CHECK INSTALLATION OF INTAKE DOOR MOTOR

Check intake door motor is properly installed. Refer to [HAC-162, "Exploded View"](#).

Is the inspection result normal?

B263D, B263E, B263F INTAKE DOOR MOTOR

[AUTOMATIC AIR CONDITIONING]

< DTC/CIRCUIT DIAGNOSIS >

- YES >> Replace intake door motor. Refer to [HAC-164. "INTAKE DOOR MOTOR : Removal and Installation"](#).
NO >> Repair or replace malfunctioning part.

3. CHECK INTAKE DOOR MOTOR COMMUNICATION SIGNAL CIRCUIT

1. Turn ignition switch OFF.
2. Disconnect intake door motor and A/C auto amp. connector.
3. Check continuity between intake door motor harness connector and A/C auto amp. harness connector.

Intake door motor		A/C auto amp.		Continuity
Connector	Terminal	Connector	Terminal	
M128	2	M50	16	Yes

Is the inspection result normal?

- YES >> Replace A/C auto amp. Refer to [HAC-156. "Removal and Installation"](#).
NO >> Repair harness or connector.

A
B
C
D
E
F
G
H
J
K
L
M
N
O
P

HAC

B2799, B279A AIR MIX DOOR MOTOR (REAR)

< DTC/CIRCUIT DIAGNOSIS >

[AUTOMATIC AIR CONDITIONING]

B2799, B279A AIR MIX DOOR MOTOR (REAR)

DTC Logic

INFOID:000000008901755

DTC DETECTION LOGIC

DTC	Items (CONSULT screen terms)	DTC detection condition	Possible cause
B2664	REAR AIR MIX DOOR MOT	Air mix door motor (rear) PBR position 95% or more	<ul style="list-style-type: none"> Air mix door motor (rear) (PBR internal circuit is open or shorted) Air mix door motor (rear) installation condition A/C auto amp. Harness and connector (LIN communication line is open or shorted)
B2665		Air mix door motor (rear) PBR position 5% or less	

DTC CONFIRMATION PROCEDURE

1. PERFORM DTC CONFIRMATION PROCEDURE

④ With CONSULT

- Turn ignition switch ON.
- Using CONSULT, perform "SELF-DIAGNOSIS RESULTS" of HVAC.
- Check if any DTC No. is displayed in the self-diagnosis results.

Is DTC detected?

- YES >> Refer to [HAC-104. "Diagnosis Procedure"](#).
 NO >> Inspection End.

Diagnosis Procedure

INFOID:000000008901756

Regarding Wiring Diagram information, refer to [HAC-50. "Wiring Diagram"](#).

1. CHECK AIR MIX DOOR MOTOR (REAR) COMMUNICATION SIGNAL

- Turn ignition switch ON.
- Check output waveform between air mix door motor (rear) harness connector and ground with the oscilloscope.

+		-	Output waveform
Air mix door motor (rear)	Connector		
Terminal	Connector	Terminal	
	M132	2	Ground

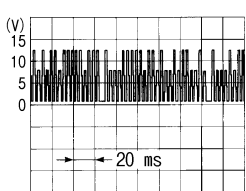

SJIA1453J

Is the inspection result normal?

- YES >> GO TO 2.
 NO >> GO TO 3.

2. CHECK INSTALLATION OF AIR MIX DOOR MOTOR (REAR)

Check air mix door motor (rear) is properly installed. Refer to [HAC-162. "Exploded View"](#).

B2799, B279A AIR MIX DOOR MOTOR (REAR)

[AUTOMATIC AIR CONDITIONING]

< DTC/CIRCUIT DIAGNOSIS >

Is the inspection result normal?

- YES >> Replace air mix door motor (rear). Refer to [HAC-164, "AIR MIX DOOR MOTOR : Removal and Installation - Air Mix Door Motor \(Rear\)"](#).
NO >> Repair or replace malfunctioning part.

3. CHECK AIR MIX DOOR MOTOR (REAR) COMMUNICATION SIGNAL CIRCUIT

1. Turn ignition switch OFF.
2. Disconnect air mix door motor (rear) and A/C auto amp. connector.
3. Check continuity between air mix door motor (rear) harness connector and A/C auto amp. harness connector.

Air mix door motor (rear)		A/C auto amp.		Continuity
Connector	Terminal	Connector	Terminal	
M132	2	M50	16	Yes

Is the inspection result normal?

- YES >> Replace A/C auto amp. Refer to [HAC-156, "Removal and Installation"](#).
NO >> Repair harness or connector.

A
B
C
D
E
F
G
H
J
K
L
M
N
O
P

HAC

B279B, B279C MODE DOOR MOTOR (REAR)

< DTC/CIRCUIT DIAGNOSIS >

[AUTOMATIC AIR CONDITIONING]

B279B, B279C MODE DOOR MOTOR (REAR)

DTC Logic

INFOID:000000008901757

DTC DETECTION LOGIC

DTC	Items (CONSULT screen terms)	DTC detection condition	Possible cause
B279B	REAR MODE DOOR MOT	When the malfunctioning door position is detected at VENT position	<ul style="list-style-type: none"> Mode door motor (rear) (PBR internal circuit is open or shorted) A/C auto amp. Harness and connector (LIN communication line is open or shorted)
B279C		When the malfunctioning door position is detected at FOOT position	

DTC CONFIRMATION PROCEDURE

1. PERFORM DTC CONFIRMATION PROCEDURE

ⓐ With CONSULT

- Turn ignition switch ON.
- Using CONSULT, perform "SELF-DIAGNOSIS RESULTS" of HVAC.
- Check if any DTC No. is displayed in the self-diagnosis results.

Is DTC detected?

- YES >> Refer to [HAC-106. "Diagnosis Procedure"](#).
 NO >> Inspection End.

Diagnosis Procedure

INFOID:000000008901758

Regarding Wiring Diagram information, refer to [HAC-50. "Wiring Diagram"](#).

1. CHECK MODE DOOR MOTOR (REAR) COMMUNICATION SIGNAL

- Turn ignition switch ON.
- Check output waveform between mode door motor (rear) harness connector and ground with the oscilloscope.

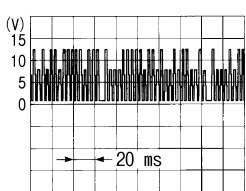
+		-	Output waveform
Mode door motor (rear)			
Connector	Terminal		
M13	2	Ground	 <p style="text-align: right;">SJIA1453J</p>

Is the inspection result normal?

- YES >> GO TO 2.
 NO >> GO TO 3.

2. CHECK INSTALLATION OF MODE DOOR MOTOR (REAR)

Check mode door motor (rear) is properly installed. Refer to [HAC-162. "Exploded View"](#).

Is the inspection result normal?

B279B, B279C MODE DOOR MOTOR (REAR)

[AUTOMATIC AIR CONDITIONING]

< DTC/CIRCUIT DIAGNOSIS >

- YES >> Replace mode door motor (rear). Refer to [HAC-163. "MODE DOOR MOTOR : Removal and Installation - Mode Door Motor \(Rear\)".](#)
- NO >> Repair or replace malfunctioning part.

3. CHECK MODE DOOR MOTOR (REAR) COMMUNICATION SIGNAL CIRCUIT

1. Turn ignition switch OFF.
2. Disconnect mode door motor (rear) and A/C auto amp. connector.
3. Check continuity between mode door motor (rear) harness connector and A/C auto amp. harness connector.

Mode door motor (rear)		A/C auto amp.		Continuity
Connector	Terminal	Connector	Terminal	
M13	2	M50	16	Yes

Is the inspection result normal?

- YES >> Replace A/C auto amp. Refer to [HAC-156. "Removal and Installation".](#)
- NO >> Repair harness or connector.

A
B
C
D
E
F
G
H
J
K
L
M
N
O
P

HAC

B279D, B279E REAR SHUT-OFF DOOR MOTOR

< DTC/CIRCUIT DIAGNOSIS >

[AUTOMATIC AIR CONDITIONING]

B279D, B279E REAR SHUT-OFF DOOR MOTOR

DTC Logic

INFOID:000000008901759

DTC DETECTION LOGIC

DTC	Items (CONSULT screen terms)	DTC detection condition	Possible cause
B279D	REAR SHUT DOOR MOT	When the malfunctioning door position is detected at open position	<ul style="list-style-type: none"> • Rear shut door motor (PBR internal circuit is open or shorted) • A/C auto amp. • Harness and connector (LIN communication line is open or shorted)
B279E		When the malfunctioning door position is detected at closed position	

DTC CONFIRMATION PROCEDURE

1. PERFORM DTC CONFIRMATION PROCEDURE

ⓐ With CONSULT

1. Turn ignition switch ON.
2. Using CONSULT, perform "SELF-DIAGNOSIS RESULTS" of HVAC.
3. Check if any DTC No. is displayed in the self-diagnosis results.

Is DTC detected?

- YES >> Refer to [HAC-108. "Diagnosis Procedure"](#).
 NO >> Inspection End.

Diagnosis Procedure

INFOID:000000008901760

Regarding Wiring Diagram information, refer to [HAC-50. "Wiring Diagram"](#).

1. CHECK REAR SHUT-OFF DOOR MOTOR COMMUNICATION SIGNAL

1. Turn ignition switch ON.
2. Check output waveform between rear shut-off door motor harness connector and ground with the oscilloscope.

+		-	Output waveform
Mode door motor (rear)			
Connector	Terminal		
M12	2	Ground	

Is the inspection result normal?

- YES >> GO TO 2.
 NO >> GO TO 3.

2. CHECK INSTALLATION OF REAR SHUT-OFF DOOR MOTOR

Check rear shut-off door motor is properly installed. Refer to [HAC-162. "Exploded View"](#).

Is the inspection result normal?

B279D, B279E REAR SHUT-OFF DOOR MOTOR

[AUTOMATIC AIR CONDITIONING]

< DTC/CIRCUIT DIAGNOSIS >

- YES >> Replace shut-off door motor. Refer to [HAC-164. "REAR SHUT-OFF DOOR MOTOR : Removal and Installation"](#).
- NO >> Repair or replace malfunctioning part.

3. CHECK MODE DOOR MOTOR (REAR) COMMUNICATION SIGNAL CIRCUIT

1. Turn ignition switch OFF.
2. Disconnect rear shut-off door motor and A/C auto amp. connector.
3. Check continuity between rear shut-off door motor harness connector and A/C auto amp. harness connector.

Rear shut-off door motor		A/C auto amp.		Continuity
Connector	Terminal	Connector	Terminal	
M12	2	M50	16	Yes

Is the inspection result normal?

- YES >> Replace A/C auto amp. Refer to [HAC-156. "Removal and Installation"](#).
- NO >> Repair harness or connector.

A
B
C
D
E
F
G
H
J
K
L
M
N
O
P

HAC

B2796, B2797, B2798 COMMUNICATION ERROR

< DTC/CIRCUIT DIAGNOSIS >

[AUTOMATIC AIR CONDITIONING]

B2796, B2797, B2798 COMMUNICATION ERROR

DTC Logic

INFOID:000000008901761

DTC DETECTION LOGIC

DTC	Items (CONSULT screen terms)	DTC detection condition	Possible cause
B2796	Communication error	When A/C auto amp. is not transmitting or receiving communication signal for 2 or more seconds.	<ul style="list-style-type: none">• Rear control unit• A/C auto amp.• Harness and connector (Communication line is open or shorted)
B2797		When display unit is not transmitting or receiving communication signal for 2 or more seconds.	
B2798		When rear control unit is not transmitting or receiving communication signal for 2 or more seconds.	

DTC CONFIRMATION PROCEDURE

1. PERFORM DTC CONFIRMATION PROCEDURE

 With CONSULT

1. Turn ignition switch ON.
2. Using CONSULT, perform "SELF-DIAGNOSIS RESULTS" of HVAC.
3. Check if any DTC No. is displayed in the self-diagnosis results.

Is DTC detected?

YES >> Refer to [HAC-110, "Diagnosis Procedure"](#).

NO >> Inspection End.

Diagnosis Procedure

INFOID:000000008901762

Regarding Wiring Diagram information, refer to [HAC-50, "Wiring Diagram"](#).

1. CHECK COMMUNICATION SIGNAL CIRCUIT (A/C AUTO AMP. → REAR AIR CONTROL) FOR OPEN

1. Turn ignition switch OFF.
2. Disconnect rear air control and A/C auto amp. connector.
3. Check continuity between rear air control harness connector and A/C auto amp. harness connector.

Rear air control		A/C auto amp.		Continuity
Connector	Terminal	Connector	Terminal	
M258	9	M50	5	Yes

Is the inspection result normal?

YES >> GO TO 2.

NO >> Repair harness or connector.

2. CHECK COMMUNICATION SIGNAL CIRCUIT (A/C AUTO AMP. → REAR AIR CONTROL) FOR SHORT

Check continuity between rear air control harness connector and ground.

Rear air control		—	Continuity
Connector	Terminal		
M258	9	Ground	No

Is the inspection result normal?

YES >> GO TO 3.

B2796, B2797, B2798 COMMUNICATION ERROR

[AUTOMATIC AIR CONDITIONING]

< DTC/CIRCUIT DIAGNOSIS >

NO >> Repair harness or connector.

3. CHECK COMMUNICATION SIGNAL CIRCUIT (REAR AIR CONTROL → A/C AUTO AMP.) CIRCUIT FOR OPEN

Check continuity between rear air control harness connector and A/C auto amp. harness connector.

Rear air control		A/C auto amp.		Continuity
Connector	Terminal	Connector	Terminal	
M258	10	M50	25	Yes

Is the inspection result normal?

YES >> GO TO 4.

NO >> Repair harness or connector.

4. CHECK COMMUNICATION SIGNAL CIRCUIT (REAR AIR CONTROL → A/C AUTO AMP.) CIRCUIT FOR SHORT

Check continuity between rear air control harness connector and ground.

Rear air control		—	Continuity
Connector	Terminal		
M258	10	Ground	No

Is the inspection result normal?

YES >> Replace A/C auto amp. Refer to [HAC-156, "Removal and Installation"](#).

NO >> Repair harness or connector.

A
B
C
D
E
F
G
H
J
K
L
M
N
O
P

HAC

B27B0 A/C AUTO AMP.

< DTC/CIRCUIT DIAGNOSIS >

[AUTOMATIC AIR CONDITIONING]

B27B0 A/C AUTO AMP.

DTC Logic

INFOID:000000008901763

DTC DETECTION LOGIC

NOTE:

- If DTC is displayed along with DTC U1000, first perform the trouble diagnosis for DTC U1000. Refer to [HAC-82, "DTC Logic"](#).
- If DTC is displayed along with DTC U1010, first perform the trouble diagnosis for DTC U1010. [HAC-83, "DTC Logic"](#).

DTC	Items (CONSULT screen terms)	DTC detection condition	Possible cause
B27B0	A/C AUTO AMP.	A/C auto amp. EEPROM system is malfunctioning.	A/C auto amp.

DTC CONFIRMATION PROCEDURE

1. PERFORM DTC CONFIRMATION PROCEDURE

Ⓟ With CONSULT

1. Turn ignition switch ON.
2. Using CONSULT, perform "SELF-DIAGNOSIS RESULTS" of HVAC.
3. Check if any DTC No. is displayed in the self-diagnosis results.

Is DTC detected?

- YES >> Refer to [HAC-112, "Diagnosis Procedure"](#).
NO >> Inspection End.

Diagnosis Procedure

INFOID:000000008901764

1. PERFORM SELF DIAGNOSTIC

Ⓟ With CONSULT

1. Turn ignition switch ON.
2. Select "Self Diagnostic Result" mode of "HVAC" using CONSULT.
3. Touch "ERASE".
4. Turn ignition switch OFF.
5. Turn ignition switch ON.
6. Perform "DTC CONFIRMATION PROCEDURE". Refer to [HAC-112, "DTC Logic"](#).

Is DTC detected again?

- YES >> Replace A/C auto amp. Refer to [HAC-156, "Removal and Installation"](#).
NO >> Inspection End.

POWER SUPPLY AND GROUND CIRCUIT

< DTC/CIRCUIT DIAGNOSIS >

[AUTOMATIC AIR CONDITIONING]

POWER SUPPLY AND GROUND CIRCUIT

A/C AUTO AMP.

A/C AUTO AMP. : Diagnosis Procedure

INFOID:000000008901765

Regarding Wiring Diagram information, refer to [HAC-50. "Wiring Diagram"](#).

1. CHECK FUSE

Check fuses [No. 14 and 30, located in the fuse block (J/B)].

NOTE:

Refer to [PG-80. "Terminal Arrangement"](#).

Is the inspection result normal?

YES >> GO TO 2.

NO >> Replace the blown fuse after repairing the affected circuit.

2. CHECK A/C AUTO AMP. POWER SUPPLY

1. Turn ignition switch OFF.
2. Disconnect A/C auto amp. connector.
3. Check voltage between A/C auto amp. harness connector and ground.

+		-	Voltage		
A/C auto amp.			Ignition switch position		
Connector	Terminal		OFF	ACC	ON
M50	23	Ground	Approx. 0 V	Approx. 0 V	Battery voltage
	3		Battery voltage	Battery voltage	Battery voltage

Is the inspection result normal?

YES >> GO TO 3.

NO >> Repair harness or connector between A/C auto amp. and fuse block (J/B).

3. CHECK A/C AUTO AMP. GROUND CIRCUIT

1. Turn ignition switch OFF.
2. Check continuity between A/C auto amp. harness connector and ground.

A/C auto amp.		—	Continuity
Connector	Terminal		
M50	2	Ground	Yes
	22		

Is the inspection result normal?

YES >> Inspection End.

NO >> Repair harness or connector.

AIR MIX DOOR MOTOR (DRIVER SIDE)

AIR MIX DOOR MOTOR (DRIVER SIDE) : Diagnosis Procedure

INFOID:000000008901766

Regarding Wiring Diagram information, refer to [HAC-50. "Wiring Diagram"](#).

1. CHECK AIR MIX DOOR MOTOR (DRIVER SIDE) POWER SUPPLY

1. Turn ignition switch ON.
2. Check voltage between air mix door motor (driver side) harness connector and ground.

POWER SUPPLY AND GROUND CIRCUIT

< DTC/CIRCUIT DIAGNOSIS >

[AUTOMATIC AIR CONDITIONING]

+		-	Voltage (Approx.)
Air mix door motor (driver side)			
Connector	Terminal		
M130	1	Ground	Battery voltage

Is the inspection result normal?

- YES >> GO TO 2.
- NO >> GO TO 4.

2. CHECK AIR MIX DOOR MOTOR (DRIVER SIDE) GROUND CIRCUIT

1. Turn ignition switch OFF.
2. Disconnect air mix door motor (driver side) connector.
3. Check continuity between air mix door motor (driver side) harness connector and ground.

Air mix door motor (driver side)		—	Continuity
Connector	Terminal		
M130	3	Ground	Yes

Is the inspection result normal?

- YES >> GO TO 3.
- NO >> Repair harness or connector.

3. CHECK INSTALLATION OF AIR MIX DOOR MOTOR (DRIVER SIDE)

Check air mix door motor (driver side) is properly installed. Refer to [HAC-162, "Exploded View"](#).

Is the inspection result normal?

- YES >> Replace air mix door motor (driver side). Refer to [HAC-164, "AIR MIX DOOR MOTOR : Removal and Installation - Air Mix Door Motor \(Driver Side\)"](#).
- NO >> Repair or replace malfunctioning part.

4. CHECK AIR MIX DOOR MOTOR (DRIVER SIDE) POWER SUPPLY CIRCUIT

1. Turn ignition switch OFF.
2. Disconnect air mix door motor (driver side) connector and A/C auto amp. connector.
3. Check continuity between air mix door motor (driver side) harness connector and A/C auto amp. harness connector.

Air mix door motor (driver side)		A/C auto amp.		Continuity
Connector	Terminal	Connector	Terminal	
M130	1	M50	17	Yes

Is the inspection result normal?

- YES >> Replace A/C auto amp. Refer to [HAC-156, "Removal and Installation"](#).
- NO >> Repair harness or connector.

AIR MIX DOOR MOTOR (PASSENGER SIDE)

AIR MIX DOOR MOTOR (PASSENGER SIDE) : Diagnosis Procedure

INFOID:000000008901767

Regarding Wiring Diagram information, refer to [HAC-50, "Wiring Diagram"](#).

1. CHECK AIR MIX DOOR MOTOR (PASSENGER SIDE) POWER SUPPLY

1. Turn ignition switch ON.
2. Check voltage between air mix door motor (passenger side) harness connector and ground.

POWER SUPPLY AND GROUND CIRCUIT

< DTC/CIRCUIT DIAGNOSIS >

[AUTOMATIC AIR CONDITIONING]

+		-	Voltage (Approx.)
Connector	Terminal		
M131	1	Ground	Battery voltage

Is the inspection result normal?

YES >> GO TO 2.

NO >> GO TO 4.

2. CHECK AIR MIX DOOR MOTOR (PASSENGER SIDE) GROUND CIRCUIT

1. Turn ignition switch OFF.
2. Disconnect air mix door motor (passenger side) connector.
3. Check continuity between air mix door motor (passenger side) harness connector and ground.

Air mix door motor (passenger side)		—	Continuity
Connector	Terminal		
M131	3	Ground	Yes

Is the inspection result normal?

YES >> GO TO 3.

NO >> Repair harness or connector.

3. CHECK INSTALLATION OF AIR MIX DOOR MOTOR (PASSENGER SIDE)

Check air mix door motor (passenger side) is properly installed. Refer to [HAC-162, "Exploded View"](#).

Is the inspection result normal?

YES >> Replace air mix door motor (passenger side). Refer to [HAC-164, "AIR MIX DOOR MOTOR : Removal and Installation - Air Mix Door Motor \(Passenger Side\)"](#).

NO >> Repair or replace malfunctioning part.

4. CHECK AIR MIX DOOR MOTOR (PASSENGER SIDE) POWER SUPPLY CIRCUIT

1. Turn ignition switch OFF.
2. Disconnect air mix door motor (passenger side) connector and A/C auto amp. connector.
3. Check continuity between air mix door motor (passenger side) harness connector and A/C auto amp. harness connector.

Air mix door motor (passenger side)		A/C auto amp.		Continuity
Connector	Terminal	Connector	Terminal	
M131	1	M50	17	Yes

Is the inspection result normal?

YES >> Replace A/C auto amp. Refer to [HAC-156, "Removal and Installation"](#).

NO >> Repair harness or connector.

AIR MIX DOOR MOTOR (REAR)

AIR MIX DOOR MOTOR (REAR) : Diagnosis Procedure

INFOID:000000008901768

Regarding Wiring Diagram information, refer to [HAC-50, "Wiring Diagram"](#).

1. CHECK AIR MIX DOOR MOTOR (REAR) POWER SUPPLY

1. Turn ignition switch ON.
2. Check voltage between air mix door motor (rear) harness connector and ground.

POWER SUPPLY AND GROUND CIRCUIT

< DTC/CIRCUIT DIAGNOSIS >

[AUTOMATIC AIR CONDITIONING]

+		-	Voltage (Approx.)
Connector	Terminal		
M132	1	Ground	Battery voltage

Is the inspection result normal?

- YES >> GO TO 2.
- NO >> GO TO 4.

2. CHECK AIR MIX DOOR MOTOR (REAR) GROUND CIRCUIT

1. Turn ignition switch OFF.
2. Disconnect air mix door motor (rear) connector.
3. Check continuity between air mix door motor (rear) harness connector and ground.

Air mix door motor (rear)		—	Continuity
Connector	Terminal		
M132	3	Ground	Yes

Is the inspection result normal?

- YES >> GO TO 3.
- NO >> Repair harness or connector.

3. CHECK INSTALLATION OF AIR MIX DOOR MOTOR (REAR)

Check air mix door motor (rear) is properly installed.

Is the inspection result normal?

- YES >> Replace air mix door motor (rear). Refer to [HAC-164, "AIR MIX DOOR MOTOR : Removal and Installation - Air Mix Door Motor \(Rear\)"](#).
- NO >> Repair or replace malfunctioning part.

4. CHECK AIR MIX DOOR MOTOR (REAR) POWER SUPPLY CIRCUIT

1. Turn ignition switch OFF.
2. Disconnect air mix door motor (rear) connector and A/C auto amp. connector.
3. Check continuity between air mix door motor (rear) harness connector and A/C auto amp. harness connector.

Air mix door motor (rear)		A/C auto amp.		Continuity
Connector	Terminal	Connector	Terminal	
M132	1	M50	17	Yes

Is the inspection result normal?

- YES >> Replace A/C auto amp. Refer to [HAC-156, "Removal and Installation"](#).
- NO >> Repair harness or connector.

MODE DOOR MOTOR (FRONT)

MODE DOOR MOTOR (FRONT) : Diagnosis Procedure

INFOID:000000008901769

Regarding Wiring Diagram information, refer to [HAC-50, "Wiring Diagram"](#).

1. CHECK MODE DOOR MOTOR (FRONT) POWER SUPPLY

1. Turn ignition switch ON.
2. Check voltage between mode door motor (front) harness connector and ground.

POWER SUPPLY AND GROUND CIRCUIT

< DTC/CIRCUIT DIAGNOSIS >

[AUTOMATIC AIR CONDITIONING]

+		-	Voltage (Approx.)
Mode door motor (front)			
Connector	Terminal		
M129	1	Ground	Battery voltage

Is the inspection result normal?

YES >> GO TO 2.

NO >> GO TO 4.

2. CHECK MODE DOOR MOTOR (FRONT) GROUND CIRCUIT

1. Turn ignition switch OFF.
2. Disconnect mode door motor (front) connector.
3. Check continuity between mode door motor (front) harness connector and ground.

Mode door motor (front)		—	Continuity
Connector	Terminal		
M129	3	Ground	Yes

Is the inspection result normal?

YES >> GO TO 3.

NO >> Repair harness or connector.

3. CHECK INSTALLATION OF MODE DOOR MOTOR (FRONT) CONTROL LINKAGE

Check mode door motor (front) control linkage is properly installed. Refer to [HAC-162. "Exploded View"](#).

Is the inspection result normal?

YES >> Replace mode door motor (front). Refer to [HAC-163. "MODE DOOR MOTOR : Removal and Installation - Mode Door Motor \(Front\)"](#).

NO >> Repair or replace malfunctioning part.

4. CHECK MODE DOOR MOTOR (FRONT) POWER SUPPLY CIRCUIT

1. Turn ignition switch OFF.
2. Disconnect mode door motor (front) connector and A/C auto amp. connector.
3. Check continuity between mode door motor (front) harness connector and A/C auto amp. harness connector.

Mode door motor (front)		A/C auto amp.		Continuity
Connector	Terminal	Connector	Terminal	
M129	1	M50	17	Yes

Is the inspection result normal?

YES >> Replace A/C auto amp. Refer to [HAC-156. "Removal and Installation"](#).

NO >> Repair harness or connector.

MODE DOOR MOTOR (REAR)

MODE DOOR MOTOR (REAR) : Diagnosis Procedure

INFOID:000000008901770

Regarding Wiring Diagram information, refer to [HAC-50. "Wiring Diagram"](#).

1. CHECK MODE DOOR MOTOR (REAR) POWER SUPPLY

1. Turn ignition switch ON.
2. Check voltage between mode door motor (rear) harness connector and ground.

POWER SUPPLY AND GROUND CIRCUIT

< DTC/CIRCUIT DIAGNOSIS >

[AUTOMATIC AIR CONDITIONING]

+		-	Voltage (Approx.)
Mode door motor (rear)			
Connector	Terminal		
M13	1	Ground	Battery voltage

Is the inspection result normal?

- YES >> GO TO 2.
- NO >> GO TO 4.

2. CHECK MODE DOOR MOTOR (REAR) GROUND CIRCUIT

1. Turn ignition switch OFF.
2. Disconnect mode door motor (rear) connector.
3. Check continuity between mode door motor (rear) harness connector and ground.

Mode door motor (rear)		—	Continuity
Connector	Terminal		
M13	3	Ground	Yes

Is the inspection result normal?

- YES >> GO TO 3.
- NO >> Repair harness or connector.

3. CHECK INSTALLATION OF MODE DOOR MOTOR (REAR)

Check mode door motor (rear) is properly installed. Refer to [HAC-162. "Exploded View"](#).

Is the inspection result normal?

- YES >> Replace mode door motor (rear). Refer to [HAC-163. "MODE DOOR MOTOR : Removal and Installation - Mode Door Motor \(Rear\)"](#).
- NO >> Repair or replace malfunctioning part.

4. CHECK MODE DOOR MOTOR (REAR) POWER SUPPLY CIRCUIT

1. Turn ignition switch OFF.
2. Disconnect mode door motor (rear) connector and A/C auto amp. connector.
3. Check continuity between mode door motor (rear) harness connector and A/C auto amp. harness connector.

Mode door motor (rear)		A/C auto amp.		Continuity
Connector	Terminal	Connector	Terminal	
M13	1	M50	17	Yes

Is the inspection result normal?

- YES >> Replace A/C auto amp. Refer to [HAC-156. "Removal and Installation"](#).
- NO >> Repair harness or connector.

INTAKE DOOR MOTOR

INTAKE DOOR MOTOR : Diagnosis Procedure

INFOID:000000008901771

Regarding Wiring Diagram information, refer to [HAC-50. "Wiring Diagram"](#).

1. CHECK INTAKE MODE DOOR MOTOR POWER SUPPLY

1. Turn ignition switch ON.
2. Check voltage between intake mode door motor harness connector and ground.

POWER SUPPLY AND GROUND CIRCUIT

< DTC/CIRCUIT DIAGNOSIS >

[AUTOMATIC AIR CONDITIONING]

+		-	Voltage (Approx.)
Connector	Terminal		
M128	1	Ground	Battery voltage

Is the inspection result normal?

- YES >> GO TO 2.
- NO >> GO TO 4.

2.CHECK INTAKE MODE DOOR MOTOR GROUND CIRCUIT

1. Turn ignition switch OFF.
2. Disconnect intake mode door motor connector.
3. Check continuity between intake mode door motor harness connector and ground.

Intake mode door motor		—	Continuity
Connector	Terminal		
M128	3	Ground	Yes

Is the inspection result normal?

- YES >> GO TO 3.
- NO >> Repair harness or connector.

3.CHECK INSTALLATION OF INTAKE MODE DOOR MOTOR

Check intake mode door motor is properly installed. Refer to [HAC-162, "Exploded View"](#).

Is the inspection result normal?

- YES >> Replace intake mode door motor. Refer to [HAC-164, "INTAKE DOOR MOTOR : Removal and Installation"](#).
- NO >> Repair or replace malfunctioning part.

4.CHECK INTAKE MODE DOOR MOTOR POWER SUPPLY CIRCUIT

1. Turn ignition switch OFF.
2. Disconnect intake mode door motor connector and A/C auto amp. connector.
3. Check continuity between intake mode door motor harness connector and A/C auto amp. harness connector.

Intake mode door motor		A/C auto amp.		Continuity
Connector	Terminal	Connector	Terminal	
M128	1	M50	17	Yes

Is the inspection result normal?

- YES >> Replace A/C auto amp. Refer to [HAC-156, "Removal and Installation"](#).
- NO >> Repair harness or connector.

A/C SWITCH ASSEMBLY

A/C SWITCH ASSEMBLY : Component Function Check

INFOID:000000008934183

WITH BASE AUDIO SYSTEM

1.CHECK OPERATION

1. Press the AUTO switch, and then check that "AUTO" is shown on the display.
2. Operate the temperature control switch (driver side). Check that the fan speed or outlet changes. (The discharge air temperature or fan speed varies depending on the ambient temperature, in-vehicle temperature, and temperature setting.)

Does it operate normally?

- YES >> Inspection End.

POWER SUPPLY AND GROUND CIRCUIT

[AUTOMATIC AIR CONDITIONING]

< DTC/CIRCUIT DIAGNOSIS >

NO >> Perform trouble diagnosis for the A/C switch assembly. Refer to [HAC-120. "A/C SWITCH ASSEMBLY : Diagnosis Procedure"](#).

A/C SWITCH ASSEMBLY : Diagnosis Procedure

INFOID:000000008934184

WITH BASE AUDIO SYSTEM

Regarding Wiring Diagram information, refer to [HAC-50. "Wiring Diagram"](#).

1. CHECK FUSE

Check 10A fuse [No. 30, located in the fuse block (J/B)].

NOTE:

Refer to [PG-80. "Terminal Arrangement"](#).

Is the inspection result normal?

YES >> GO TO 2.

NO >> Replace the blown fuse after repairing the affected circuit.

2. CHECK A/C SWITCH ASSEMBLY POWER SUPPLY

1. Turn ignition switch OFF.
2. Disconnect A/C switch assembly connector.
3. Turn ignition switch ON.
4. Check voltage between A/C switch assembly connector and ground.

+		-	Voltage (Approx.)
A/C switch assembly			
Connector	Terminal		
M146	1	Ground	Battery voltage

Is the inspection result normal?

YES >> GO TO 3.

NO >> Repair harness or connector between A/C switch assembly and fuse block (J/B).

3. CHECK A/C SWITCH ASSEMBLY GROUND CIRCUIT

1. Turn ignition switch OFF.
2. Check continuity between A/C switch assembly harness connector and ground.

A/C switch assembly		—	Continuity
Connector	Terminal		
M146	2	Ground	Yes

Is the inspection result normal?

YES >> Replace A/C switch assembly.

NO >> Repair harness or connector.

A/C DISPLAY UNIT

A/C DISPLAY UNIT : Diagnosis Procedure

INFOID:000000008940707

WITH BASE AUDIO SYSTEM

Regarding Wiring Diagram information, refer to [HAC-50. "Wiring Diagram"](#).

1. CHECK FUSE

Check 10A fuse [No. 30, located in the fuse block (J/B)].

NOTE:

Refer to [PG-80. "Terminal Arrangement"](#).

Is the inspection result normal?

POWER SUPPLY AND GROUND CIRCUIT

[AUTOMATIC AIR CONDITIONING]

< DTC/CIRCUIT DIAGNOSIS >

YES >> GO TO 2.

NO >> Replace the blown fuse after repairing the affected circuit.

2.CHECK A/C DISPLAY UNIT POWER SUPPLY

1. Turn ignition switch OFF.
2. Disconnect A/C display unit connector.
3. Turn ignition switch ON.
4. Check voltage between A/C display unit connector and ground.

+		-	Voltage (Approx.)
A/C display unit			
Connector	Terminal		
M148	6	Ground	Battery voltage

Is the inspection result normal?

YES >> GO TO 3.

NO >> Repair harness or connector between A/C display unit and fuse block (J/B).

3.CHECK A/C DISPLAY UNIT GROUND CIRCUIT

1. Turn ignition switch OFF.
2. Check continuity between A/C display unit harness connector and ground.

A/C display unit		—	Continuity
Connector	Terminal		
M148	1	Ground	Yes

Is the inspection result normal?

YES >> Replace A/C display unit.

NO >> Repair harness or connector.

REAR SHUT-OFF DOOR MOTOR

REAR SHUT-OFF DOOR MOTOR : Diagnosis Procedure

INFOID:000000008901772

Regarding Wiring Diagram information, refer to [HAC-50. "Wiring Diagram"](#).

1.CHECK SHUT-OFF DOOR MOTOR POWER SUPPLY

1. Turn ignition switch ON.
2. Check voltage between shut-off door motor harness connector and ground.

+		-	Voltage (Approx.)
Shut-off door motor			
Connector	Terminal		
M12	1	Ground	Battery voltage

Is the inspection result normal?

YES >> GO TO 2.

NO >> GO TO 4.

2.CHECK SHUT-OFF DOOR MOTOR GROUND CIRCUIT

1. Turn ignition switch OFF.
2. Disconnect shut-off door motor connector.
3. Check continuity between shut-off door motor harness connector and ground.

A
B
C
D
E
F
G
H
J
K
L
M
N
O
P

HAC

POWER SUPPLY AND GROUND CIRCUIT

< DTC/CIRCUIT DIAGNOSIS >

[AUTOMATIC AIR CONDITIONING]

Shut-off door motor		—	Continuity
Connector	Terminal		
M12	3	Ground	Yes

Is the inspection result normal?

YES >> GO TO 3.

NO >> Repair harness or connector.

3. CHECK INSTALLATION OF SHUT-OFF DOOR MOTOR

Check shut-off door motor is properly installed. Refer to [HAC-162, "Exploded View"](#).

Is the inspection result normal?

YES >> Replace shut-off door motor. Refer to [HAC-164, "REAR SHUT-OFF DOOR MOTOR : Removal and Installation"](#).

NO >> Repair or replace malfunctioning part.

4. CHECK SHUT-OFF DOOR MOTOR POWER SUPPLY CIRCUIT

1. Turn ignition switch OFF.
2. Disconnect shut-off door motor connector and A/C auto amp. connector.
3. Check continuity between shut-off door motor harness connector and A/C auto amp. harness connector.

Shut-off door motor		A/C auto amp.		Continuity
Connector	Terminal	Connector	Terminal	
M12	1	M50	17	Yes

Is the inspection result normal?

YES >> Replace A/C auto amp. Refer to [HAC-156, "Removal and Installation"](#).

NO >> Repair harness or connector.

REAR A/C CONTROL

REAR A/C CONTROL : Diagnosis Procedure

INFOID:000000008901773

Regarding Wiring Diagram information, refer to [HAC-50, "Wiring Diagram"](#).

1. CHECK FUSE

Check 10A fuse [No. 30, located in the fuse block (J/B)].

NOTE:

Refer to [PG-80, "Terminal Arrangement"](#).

Is the inspection result normal?

YES >> GO TO 2.

NO >> Replace the blown fuse after repairing the affected circuit.

2. CHECK REAR AIR CONTROL POWER SUPPLY

1. Turn ignition switch OFF.
2. Disconnect rear air control connector.
3. Turn ignition switch ON.
4. Check voltage between rear air control harness connector and ground.

+		-	Voltage (Approx.)
Connector	Terminal		
M258	12	Ground	Battery voltage

Is the inspection result normal?

POWER SUPPLY AND GROUND CIRCUIT

[AUTOMATIC AIR CONDITIONING]

< DTC/CIRCUIT DIAGNOSIS >

YES >> GO TO 3.

NO >> Repair harness or connector between rear air control and fuse block (J/B).

3. CHECK REAR AIR CONTROL GROUND CIRCUIT

1. Turn ignition switch OFF.
2. Check continuity between rear air control harness connector and ground.

Rear air control		—	Continuity
Connector	Terminal		
M258	1	Ground	Yes

Is the inspection result normal?

YES >> Replace rear air control. Refer to [HAC-155, "Removal and Installation"](#).

NO >> Repair harness or connector.

A
B
C
D
E
F
G
H
J
K
L
M
N
O
P

HAC

A/C SWITCH ASSEMBLY SIGNAL CIRCUIT

< DTC/CIRCUIT DIAGNOSIS >

[AUTOMATIC AIR CONDITIONING]

A/C SWITCH ASSEMBLY SIGNAL CIRCUIT

Diagnosis Procedure

INFOID:000000008934185

WITH BASE AUDIO SYSTEM

Regarding Wiring Diagram information, refer to [HAC-50. "Wiring Diagram"](#).

1. CHECK WITH SELF-DIAGNOSIS FUNCTION OF CONSULT

1. Using CONSULT, perform "SELF-DIAGNOSIS RESULTS" of HVAC.
2. Check if any DTC No. is displayed in the self-diagnosis results.

NOTE:

If DTC is displayed along with DTC U1000 or U1010, first diagnose the DTC U1000 or U1010. Refer to [HAC-82. "DTC Logic"](#) or [HAC-83. "DTC Logic"](#).

Is any DTC No. displayed?

- YES >> Perform diagnosis for the applicable DTC. Refer to [HAC-47. "DTC Index"](#).
NO >> GO TO 2.

2. CHECK TX (A/C SWITCH ASSEMBLY → A/C AUTO AMP.) CIRCUIT CONTINUITY

1. Turn ignition switch OFF.
2. Disconnect the A/C switch assembly and the A/C auto amp. connectors.
3. Check continuity between A/C switch assembly harness connector M146 terminal 4 and A/C auto amp. harness connector M50 terminal 24.

A/C switch assembly		A/C auto amp.		Continuity
Connector	Terminal	Connector	Terminal	
M146	4	M50	24	Yes

4. Check continuity between A/C switch assembly harness connector M146 terminal 4 and ground.

A/C switch assembly		—	Continuity
Connector	Terminal		
M146	4	Ground	No

Is the inspection result normal?

- YES >> GO TO 3.
NO >> Repair harness or connector.

3. CHECK RX (A/C AUTO AMP. → A/C SWITCH ASSEMBLY) CIRCUIT CONTINUITY

1. Disconnect the A/C display unit connector.
2. Check continuity between A/C switch assembly harness connector M146 terminal 3 and A/C auto amp. harness connector M50 terminal 4.

A/C switch assembly		A/C auto amp.		Continuity
Connector	Terminal	Connector	Terminal	
M146	3	M50	4	Yes

3. Check continuity between A/C switch assembly harness connector M146 terminal 3 and ground.

A/C switch assembly		—	Continuity
Connector	Terminal		
M146	3	Ground	No

Is the inspection result normal?

- YES >> Perform trouble diagnosis for the A/C switch assembly. Refer to [HAC-120. "A/C SWITCH ASSEMBLY : Diagnosis Procedure"](#).

A/C SWITCH ASSEMBLY SIGNAL CIRCUIT

< DTC/CIRCUIT DIAGNOSIS >

[AUTOMATIC AIR CONDITIONING]

NO >> Repair harness or connector.

A

B

C

D

E

F

G

H

HAC

J

K

L

M

N

O

P

A/C DISPLAY

Diagnosis Procedure

INFOID:000000008940746

WITH BASE AUDIO SYSTEM

Regarding Wiring Diagram information, refer to [HAC-50. "Wiring Diagram"](#).

1. CHECK WITH SELF-DIAGNOSIS FUNCTION OF CONSULT

1. Using CONSULT, perform "SELF-DIAGNOSIS RESULTS" of HVAC.
2. Check if any DTC No. is displayed in the self-diagnosis results.

NOTE:

If DTC is displayed along with DTC U1000 or U1010, first diagnose the DTC U1000 or U1010. Refer to [HAC-82. "DTC Logic"](#) or [HAC-83. "DTC Logic"](#).

Is any DTC No. displayed?

- YES >> Perform diagnosis for the applicable DTC. Refer to [HAC-47. "DTC Index"](#).
- NO >> GO TO 2.

2. CHECK RX (A/C AUTO AMP. → A/C DISPLAY UNIT) CIRCUIT CONTINUITY

1. Disconnect the A/C switch assembly, A/C display unit and the A/C auto amp. connectors.
2. Check continuity between A/C display unit harness connector M148 terminal 10 and A/C auto amp. harness connector M50 terminal 4.

A/C display unit		A/C auto amp.		Continuity
Connector	Terminal	Connector	Terminal	
M148	10	M50	4	Yes

3. Check continuity between A/C display unit harness connector M148 terminal 10 and ground.

A/C display unit		—	Continuity
Connector	Terminal		
M148	10	Ground	No

Is the inspection result normal?

- YES >> Perform trouble diagnosis for the A/C display unit. Refer to [HAC-120. "A/C DISPLAY UNIT : Diagnosis Procedure"](#).
- NO >> Repair harness or connector.

DOOR MOTOR

< DTC/CIRCUIT DIAGNOSIS >

[AUTOMATIC AIR CONDITIONING]

DOOR MOTOR

Diagnosis Procedure

INFOID:000000008901774

Regarding Wiring Diagram information, refer to [HAC-50. "Wiring Diagram"](#).

1. CHECK EACH DOOR MOTOR POWER SUPPLY

1. Turn ignition switch ON.
2. Check voltage between intake door motor harness connector and ground.

+		-	Voltage (Approx.)
Intake door motor			
Connector	Terminal		
M128	1	Ground	Battery voltage

Is the inspection result normal?

- YES >> GO TO 2.
NO >> GO TO 3.

2. CHECK EACH DOOR MOTOR GROUND CIRCUIT

1. Turn ignition switch OFF.
2. Disconnect intake door motor connector.
3. Check continuity between intake door motor harness connector and ground.

Intake door motor		—	Continuity
Connector	Terminal		
M128	3	Ground	Yes

Is the inspection result normal?

- YES >> Inspection End.
NO >> Repair harness or connector.

3. CHECK EACH DOOR MOTOR POWER SUPPLY CIRCUIT FOR OPEN

1. Disconnect A/C auto amp. connector.
2. Check continuity between intake door motor harness connector and A/C auto amp. harness connector.

Intake door motor		A/C auto amp.		Continuity
Connector	Terminal	Connector	Terminal	
M128	1	M50	17	Yes

Is the inspection result normal?

- YES >> GO TO 4.
NO >> Repair harness or connector.

4. CHECK EACH DOOR MOTOR POWER SUPPLY CIRCUIT FOR SHORT

1. Disconnect following connectors.
 - Air mix door motor (driver side)
 - Air mix door motor (passenger side)
 - Mode door motor (front)
 - Rear shut-off door motor
 - Air mix door motor (rear)
 - Mode door motor (rear)
2. Check continuity between intake door motor harness connector and ground.

A
B
C
D
E
F
G
H
J
K
L
M
N
O
P

HAC

DOOR MOTOR

< DTC/CIRCUIT DIAGNOSIS >

[AUTOMATIC AIR CONDITIONING]

Intake door motor		—	Continuity
Connector	Terminal		
M128	1	Ground	No

Is the inspection result normal?

YES >> Replace A/C auto amp. Refer to [HAC-156. "Removal and Installation"](#).

NO >> Repair harness or connector.

DOOR MOTOR COMMUNICATION CIRCUIT

< DTC/CIRCUIT DIAGNOSIS >

[AUTOMATIC AIR CONDITIONING]

DOOR MOTOR COMMUNICATION CIRCUIT

Diagnosis Procedure

INFOID:000000008901775

Regarding Wiring Diagram information, refer to [HAC-50. "Wiring Diagram"](#).

NOTE:

If all of door motor DTCs are detected, check this circuit.

1. CHECK EACH DOOR MOTOR COMMUNICATION SIGNAL

1. Turn ignition switch ON.
2. Check output waveform between A/C auto amp. harness connector and ground with the oscilloscope.

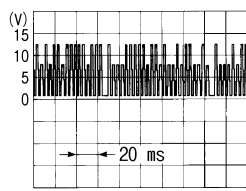
+		-	Output waveform
A/C auto amp.			
Connector	Terminal		
M50	16	Ground	 <p style="text-align: right;">SJIA1453J</p>

Is the inspection result normal?

- YES >> GO TO 2.
NO >> GO TO 3.

2. CHECK EACH DOOR MOTOR COMMUNICATION SIGNAL CIRCUIT FOR OPEN

1. Turn ignition switch OFF.
2. Disconnect A/C auto amp. connector and intake door motor connector.
3. Check continuity between A/C auto amp. harness connector and intake door motor harness connector.

A/C auto amp.		Intake door motor		Continuity
Connector	Terminal	Connector	Terminal	
M50	16	M128	2	Yes

Is the inspection result normal?

- YES >> Inspection End.
NO >> Repair harness or connector.

3. CHECK EACH DOOR MOTOR COMMUNICATION SIGNAL CIRCUIT FOR SHORT

1. Disconnect following connectors.
 - Air mix door motor (driver side)
 - Air mix door motor (passenger side)
 - Mode door motor (front)
 - Rear shut-off door motor
 - Air mix door motor (rear)
 - Mode door motor (rear)
2. Check continuity between A/C auto amp. harness connector and ground.

A/C auto amp.		—	Continuity
Connector	Terminal		
M50	16	Ground	No

A

B

C

D

E

F

G

H

HAC

J

K

L

M

N

O

P

DOOR MOTOR COMMUNICATION CIRCUIT

< DTC/CIRCUIT DIAGNOSIS >

[AUTOMATIC AIR CONDITIONING]

Is the inspection result normal?

- YES >> Replace A/C auto amp. Refer to [HAC-156, "Removal and Installation"](#).
- NO >> Repair harness or connector.

FRONT BLOWER MOTOR

< DTC/CIRCUIT DIAGNOSIS >

[AUTOMATIC AIR CONDITIONING]

FRONT BLOWER MOTOR

Diagnosis Procedure

INFOID:000000008901776

Regarding Wiring Diagram information, refer to [HAC-50. "Wiring Diagram"](#).

1. CHECK FUSE

1. Turn ignition switch OFF.
2. Check 15A fuses [Nos. 17 and 27, located in fuse block (J/B)].

NOTE:

Refer to [PG-80. "Terminal Arrangement"](#).

Is the inspection result normal?

YES >> GO TO 2.

NO >> Replace the blown fuse after repairing the affected circuit.

2. CHECK FRONT BLOWER MOTOR POWER SUPPLY

1. Disconnect front blower motor connector.
2. Turn ignition switch ON.
3. Check voltage between front blower motor harness connector and ground.

+		-	Voltage
Front blower motor			
Connector	Terminal		
M112	4	Ground	Battery voltage

Is the inspection result normal?

YES >> GO TO 3.

NO >> GO TO 6.

3. CHECK FRONT BLOWER MOTOR GROUND CIRCUIT

1. Turn ignition switch OFF.
2. Check continuity between front blower motor harness connector and ground.

Front blower motor		—	Continuity
Connector	Terminal		
M112	1	Ground	Yes

Is the inspection result normal?

YES >> GO TO 4.

NO >> Repair harness or connector.

4. CHECK FRONT BLOWER MOTOR CONTROL SIGNAL CIRCUIT

1. Disconnect A/C auto amp. connector.
2. Check continuity between front blower motor harness connector and A/C auto amp. harness connector.

Front blower motor		A/C auto amp.		Continuity
Connector	Terminal	Connector	Terminal	
M112	3	M50	18	Yes

Is the inspection result normal?

YES >> GO TO 5.

NO >> Repair the harness or connector.

5. CHECK FRONT BLOWER MOTOR CONTROL SIGNAL

A

B

C

D

E

F

G

H

HAC

J

K

L

M

N

O

P

FRONT BLOWER MOTOR

[AUTOMATIC AIR CONDITIONING]

< DTC/CIRCUIT DIAGNOSIS >

1. Reconnect front blower motor connector and A/C auto amp. connector.
2. Turn ignition switch ON.
3. Operate MODE switch to set air outlet to VENT.
4. Change fan speed from Lo to Hi, and check duty ratios between front blower motor harness connector and ground by using an oscilloscope.

NOTE:

Calculate drive signal duty ratio as shown in the figure.
T2 = Approx. 1.6 ms

Front blower motor		Condition	Duty ratio (Approx.)
Connector	Terminal	Fan speed (manual) VENT mode	
M112	3	1st	25 %
		2nd	33 %
		3rd	41 %
		4th	51 %
		5th	61 %
		6th	69 %
		7th	81 %

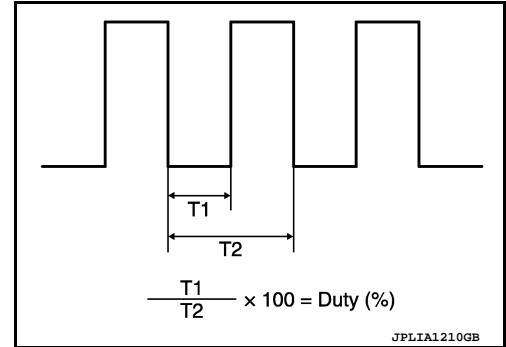

Is the inspection result normal?

YES >> Replace front blower motor. Refer to [VTL-19, "FRONT BLOWER MOTOR : Removal and Installation"](#).

NO >> Replace A/C auto amp. Refer to [HAC-156, "Removal and Installation"](#).

6. CHECK FRONT BLOWER MOTOR RELAY GROUND CIRCUIT

1. Turn ignition switch OFF.
2. Check continuity between fuse block (J/B) harness connector and ground.

Fuse block (J/B)		—	Continuity
Connector	Terminal		
M68	13R	Ground	Yes

Is the inspection result normal?

YES >> GO TO 7.

NO >> Repair harness or connector.

7. CHECK FRONT BLOWER RELAY

Check front blower motor relay. Refer to [HAC-132, "Component Inspection \(Front Blower Motor Relay\)"](#).

Is the inspection result normal?

YES >> Repair harness or connector between front blower motor and fuse block (J/B).

NO >> Replace front blower relay.

Component Inspection (Front Blower Motor)

INFOID:000000008901777

1. CHECK FRONT BLOWER MOTOR

1. Connect battery voltage to terminal 1 of front blower motor.
2. Connect ground to terminal 2 of front blower motor.

Does the front blower fan operate?

YES >> Intermittent incident. Refer to [GI-49, "Intermittent Incident"](#).

NO >> Replace front blower motor. Refer to [VTL-19, "FRONT BLOWER MOTOR : Removal and Installation"](#).

Component Inspection (Front Blower Motor Relay)

INFOID:000000008901778

1. CHECK BLOWER RELAY

FRONT BLOWER MOTOR

[AUTOMATIC AIR CONDITIONING]

< DTC/CIRCUIT DIAGNOSIS >

1. Turn ignition switch OFF.
2. Remove front blower motor relay.
3. Check continuity between front blower motor relay terminals 3 and 5 when voltage is supplied between terminals 1 and 2.

Terminals		Voltage	Continuity
3	5	ON	Yes
		OFF	No

Is the inspection result normal?

- YES >> Inspection End.
 NO >> Replace front blower motor relay.

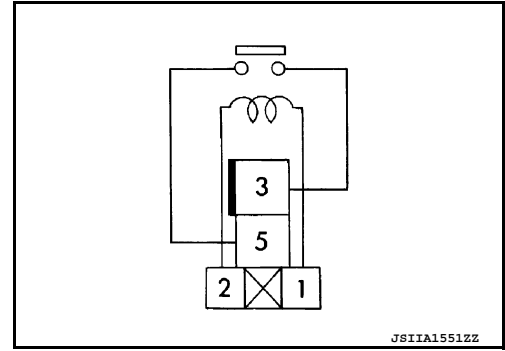

A
B
C
D
E
F
G
H
J
K
L
M
N
O
P

HAC

MAGNET CLUTCH

< DTC/CIRCUIT DIAGNOSIS >

[AUTOMATIC AIR CONDITIONING]

MAGNET CLUTCH

Component Function Check

INFOID:000000008901781

1.CHECK MAGNET CLUTCH OPERATION

Perform auto active test of IPDM E/R. Refer to [PCS-8, "Diagnosis Description"](#).

Does it operate normally?

YES >> Inspection End.

NO >> Refer to [HAC-134, "Diagnosis Procedure"](#).

Diagnosis Procedure

INFOID:000000008901782

Regarding Wiring Diagram information, refer to [HAC-50, "Wiring Diagram"](#).

1.CHECK FUSE

1. Turn ignition switch OFF.
2. Check 10A fuse (No. 53, located in IPDM E/R).

NOTE:

Refer to [PG-84, "IPDM E/R Terminal Arrangement"](#).

Is the inspection result normal?

YES >> GO TO 2.

NO >> Replace the blown fuse after repairing the affected circuit.

2.CHECK MAGNET CLUTCH POWER SUPPLY CIRCUIT

1. Disconnect compressor connector and IPDM E/R connector.
2. Check continuity between compressor harness connector and IPDM E/R harness connector.

Compressor		IPDM E/R		Continuity
Connector	Terminal	Connector	Terminal	
F3	1	F19	56	Yes

Is the inspection result normal?

YES >> GO TO 3.

NO >> Repair harness or connector.

3.CHECK MAGNET CLUTCH GROUND CIRCUIT

1. Disconnect compressor connector.
2. Check continuity between compressor harness connector and ground.

Compressor			Continuity
Connector	Terminal		
F3	2	Ground	Yes

Is the inspection result normal?

YES >> GO TO 4.

NO >> Repair harness or connector.

4.CHECK MAGNET CLUTCH

Directly apply battery voltage to the magnet clutch. Check operation visually and by sound.

Does it operate normally?

YES >> Replace IPDM E/R. Refer to [PCS-32, "Removal and Installation"](#).

NO >> Replace magnet clutch. Refer to [HA-31, "MAGNET CLUTCH : Removal and Installation of Compressor Clutch"](#).

PTC HEATER RELAY

< DTC/CIRCUIT DIAGNOSIS >

[AUTOMATIC AIR CONDITIONING]

PTC HEATER RELAY

Description

INFOID:000000008901783

Power is supplied to the PTC heater with A/C auto amp. control.

Component Function Check

INFOID:000000008901784

1. CHECK REAR WINDOW DEFOGGER RELAY POWER SUPPLY CIRCUIT

Check that an operation noise of PTC heater relay (located in relay box) can be heard when operating the rear air conditioning system in heat mode.

Is the inspection result normal?

- YES >> PTC heater relay power supply circuit is OK.
- NO >> Refer to [HAC-135, "Diagnosis Procedure"](#).

Diagnosis Procedure

INFOID:000000008901785

Regarding Wiring Diagram information, refer to [HAC-50, "Wiring Diagram"](#).

1. CHECK PTC HEATER RELAY GROUND CIRCUIT

1. Turn ignition switch ON.
2. Check voltage between A/C auto amp. connector and ground.

Terminals		Voltage (V) (Approx.)	
(+)	(-)		
A/C auto amp.	Terminal	Ground	Battery voltage
M50	19		
	39		

Is the inspection result normal?

- YES >> Replace A/C auto amp. Refer to [HAC-156, "Removal and Installation"](#).
- NO >> GO TO 2.

2. CHECK HARNESS CONTINUITY

1. Turn ignition switch OFF.
2. Disconnect A/C auto amp. and PTC heater relay connector.
3. Check continuity between A/C auto amp. connector and PTC heater relay connector.

A/C auto amp. connector	Terminal	PTC heater relay connector	Terminal	Continuity
M50	19	E11	2	Yes
	39	E12		

4. Check continuity between A/C auto amp. connector and ground.

A/C auto amp. connector	Terminal	Ground	Continuity
M50	19		No
	39		

Is the inspection result normal?

- YES >> GO TO 3.
- NO >> Repair or replace harness.

3. CHECK PTC HEATER RELAY

A
B
C
D
E
F
G
H
J
K
L
M
N
O
P

HAC

PTC HEATER RELAY

[AUTOMATIC AIR CONDITIONING]

< DTC/CIRCUIT DIAGNOSIS >

Check PTC heater relay. Refer to [HAC-136. "Component Inspection"](#).

Is the inspection result normal?

- YES >> Check intermittent incident. Refer to [GI-49. "Intermittent Incident"](#).
- NO >> Replace PTC heater relay.

Component Inspection

INFOID:000000008901786

1. CHECK PTC HEATER RELAY

1. Turn ignition switch OFF.
2. Remove PTC heater relay.
3. Check continuity between PTC heater relay terminal 3 and 5 when voltage is supplied between terminal 1 and 2.

Terminal		Voltage	Continuity
3	5	ON	Yes
		OFF	No

Is the inspection result normal?

- YES >> Inspection End.
- NO >> Replace blower relay.

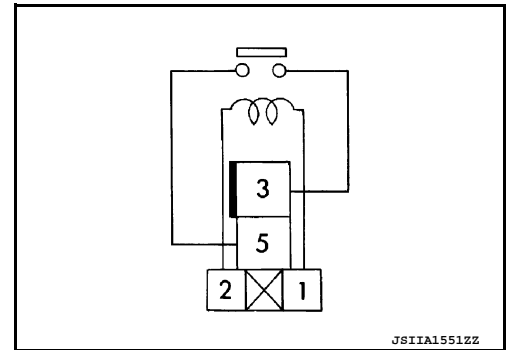

PTC HEATER

< DTC/CIRCUIT DIAGNOSIS >

[AUTOMATIC AIR CONDITIONING]

PTC HEATER

Diagnosis Procedure

INFOID:000000008901787

Regarding Wiring Diagram information, refer to [HAC-50. "Wiring Diagram"](#).

1. CHECK FUSE

1. Turn ignition switch OFF.
2. Check 30A fuse [No. 59 and 60, located in relay box].

NOTE:

Refer to [PG-81. "Terminal Arrangement"](#).

Is the inspection result normal?

YES >> GO TO 2.

NO >> Replace the blown fuse after repairing the affected circuit.

2. CHECK POWER SUPPLY CIRCUIT

1. Turn ignition switch ON.
2. Check voltage between PTC heater connector and ground.

Terminals		Condition of rear window defogger switch	Voltage (V) (Approx.)
(+)	(-)		
PTC heater connector	Terminal		
M118	1	ON	Battery voltage
		OFF	0
	3	ON	Battery voltage
		OFF	0

Is the inspection result normal?

YES >> GO TO 3.

NO >> GO TO 4.

3. CHECK GROUND CIRCUIT

1. Turn ignition switch OFF.
2. Disconnect PTC heater connector.
3. Check continuity between PTC heater connector and ground.

Rear window defogger connector	Terminal	Ground	Continuity
M117	2	Ground	Yes
	4		

Is the inspection result normal?

YES >> Replace PTC heater. Refer to [VTL-19. "CENTER BLOWER UNIT : Removal and Installation"](#).

NO >> Repair or replace harness.

4. CHECK HARNESS CONTINUITY

1. Disconnect PTC relay connectors.
2. Check continuity between PTC heater connector and PTC relay connector.

PTC heater connector	Terminal	PTC heater relay connector	Terminal	Continuity
----------------------	----------	----------------------------	----------	------------

PTC HEATER

< DTC/CIRCUIT DIAGNOSIS >

[AUTOMATIC AIR CONDITIONING]

M118	1	E11	5	Yes
	3	E12		

3. Check continuity between PTC heater connector and ground.

PTC heater connector	Terminal	Ground	Continuity
M118	1		Ground
	3		

Is the inspection result normal?

YES >> Check intermittent incident. Refer to [GI-49, "Intermittent Incident"](#).

NO >> Replace or repair harness.

REAR BLOWER MOTOR

< DTC/CIRCUIT DIAGNOSIS >

[AUTOMATIC AIR CONDITIONING]

REAR BLOWER MOTOR

Diagnosis Procedure

INFOID:000000008901788

Regarding Wiring Diagram information, refer to [HAC-50. "Wiring Diagram"](#).

REAR BLOWER MOTOR 1

1. CHECK FUSE

Check 20A fuse [No. 70, located in the fuse block (J/B)].

Is the inspection result normal?

YES >> GO TO 2.

NO >> Replace the blown fuse after repairing the affected circuit.

2. CHECK POWER SUPPLY FOR BLOWER MOTOR

1. Turn ignition switch ON.
2. Check voltage between rear blower motor harness connector and ground.

(+)		(-)	Voltage (Approx.)
Rear blower motor			
Connector	Terminal	Ground	Battery voltage
M107	1		

Is the inspection result normal?

YES >> GO TO 3.

NO >> GO TO 7.

3. CHECK POWER SUPPLY FOR REAR BLOWER MOTOR RESISTOR 1

Check voltage between rear blower motor resistor 1 harness connector and ground.

(+)		(-)	Voltage (Approx.)
Rear blower motor resistor 1			
Connector	Terminal	Ground	Battery voltage
M104	1		

Is the inspection result normal?

YES >> GO TO 4.

NO >> GO TO 8.

4. CHECK BLOWER MOTOR CONTROL SIGNAL

1. Turn mode control to VENT.
2. Turn fan control to 1st speed.
3. Check voltage between rear blower motor resistor 1 harness connector and ground.

(+)		(-)	Voltage (Approx.)
Rear blower motor resistor 1			
Connector	Terminal	Ground	2.5 V
M104	2		

Is the inspection result normal?

YES >> GO TO 5.

NO-1 >> Less than approximately 2.5 V: GO TO 9.

NO-2 >> More than approximately 10 V: Replace auto amp.

5. CHECK REAR BLOWER MOTOR RESISTOR 1 GROUND CIRCUIT

1. Disconnect rear blower motor resistor 1 connector.

A
B
C
D
E
F
G
H
HAC
J
K
L
M
N
O
P

REAR BLOWER MOTOR

< DTC/CIRCUIT DIAGNOSIS >

[AUTOMATIC AIR CONDITIONING]

2. Check continuity between rear blower motor resistor 1 harness connector and ground.

Rear blower motor resistor 1		—	Continuity
Connector	Terminal		
M104	3	Ground	Yes

Is the inspection result normal?

YES >> GO TO 6.

NO >> Repair harness or connector.

6. CHECK BLOWER MOTOR FEEDBACK SIGNAL

1. Reconnect rear blower motor resistor 1 connector.
2. Turn ignition switch ON.
3. Turn fan control to 1st speed.
4. Check voltage between auto amp. harness connector and ground.

(+)		(-)	Condition	Voltage (Approx.)
Auto amp.				
Connector	Terminal			
M50	34	Ground	Blower speed: 1st (Blower motor operating)	10 V

Is the inspection result normal?

YES >> Replace auto amp.

NO >> Repair harness or connector.

7. CHECK POWER SUPPLY OF BLOWER RELAY

1. Turn ignition switch OFF.
2. Remove blower relay.
3. Turn ignition switch ON.
4. Check voltage between rear blower relay connector terminals and ground.

(+)		(-)	Voltage (Approx.)
Rear blower relay			
Connector	Terminal		
M108	1	Ground	Battery voltage
	3		
	6		

Is the inspection result normal?

YES >> Check rear blower motor relay. Refer to [HAC-143. "Component Inspection \(Rear Blower Motor Relay\)".](#)

NO >> Repair harness or connector.

8. CHECK CIRCUIT CONTINUITY BETWEEN BLOWER MOTOR AND REAR BLOWER MOTOR RESISTOR

1. Turn ignition switch OFF.
2. Disconnect rear blower motor resistor 1 connector.
3. Check continuity between blower motor harness connector and rear blower motor resistor 1 harness connector.

Blower motor		Rear blower motor resistor 1		Continuity
Connector	Terminal	Connector	Terminal	
M107	2	M104	1	Yes

Is the inspection result normal?

REAR BLOWER MOTOR

[AUTOMATIC AIR CONDITIONING]

< DTC/CIRCUIT DIAGNOSIS >

- YES >> Replace blower motor.
NO >> Repair harness or connector.

9. CHECK REAR BLOWER MOTOR RESISTOR 1

Check rear blower motor resistor 1. Refer to [HAC-143. "Component Inspection \(Rear Blower Motor Relay\)"](#).

Is the inspection result normal?

- YES >> Replace auto amp.
NO >> Replace rear blower motor resistor 1.

REAR BLOWER MOTOR 2

1. CHECK FUSE

Check 20A fuse [Nos. 71, located in the fuse block (J/B)].

Is the inspection result normal?

- YES >> GO TO 2.
NO >> Replace fuse after repairing the affected circuit.

2. CHECK POWER SUPPLY FOR BLOWER MOTOR

- Turn ignition switch ON.
- Check voltage between rear blower motor harness connector and ground.

(+)		(-)	Voltage (Approx.)
Rear blower motor			
Connector	Terminal		
B134	1	Ground	Battery voltage

Is the inspection result normal?

- YES >> GO TO 3.
NO >> GO TO 7.

3. CHECK POWER SUPPLY FOR REAR BLOWER MOTOR RESISTOR 2

Check voltage between rear blower motor resistor 2 harness connector and ground.

(+)		(-)	Voltage (Approx.)
Rear blower motor resistor 2			
Connector	Terminal		
B133	1	Ground	Battery voltage

Is the inspection result normal?

- YES >> GO TO 4.
NO >> GO TO 8.

4. CHECK BLOWER MOTOR CONTROL SIGNAL

- Turn mode control to VENT.
- Turn fan control to 1st speed.
- Check voltage between rear blower motor resistor 2 harness connector and ground.

(+)		(-)	Voltage (Approx.)
Rear blower motor resistor 2			
Connector	Terminal		
B133	2	Ground	2.5 V

Is the inspection result normal?

- YES >> GO TO 5.
NO-1 >> Less than approximately 2.5 V: GO TO 9.
NO-2 >> More than approximately 10 V: Replace auto amp.

A
B
C
D
E
F
G
H
J
K
L
M
N
O
P

HAC

REAR BLOWER MOTOR

< DTC/CIRCUIT DIAGNOSIS >

[AUTOMATIC AIR CONDITIONING]

5. CHECK REAR BLOWER MOTOR RESISTOR 2 GROUND CIRCUIT

1. Disconnect rear blower motor resistor 2 connector.
2. Check continuity between rear blower motor resistor 2 harness connector and ground.

Rear blower motor resistor 2		—	Continuity
Connector	Terminal		
B133	3	Ground	Yes

Is the inspection result normal?

YES >> GO TO 6.

NO >> Repair harness or connector.

6. CHECK BLOWER MOTOR FEEDBACK SIGNAL

1. Reconnect rear blower motor resistor 2 connector.
2. Turn ignition switch ON.
3. Turn fan control to 1st speed.
4. Check voltage between auto amp. harness connector and ground.

(+)		(-)	Condition	Voltage (Approx.)
Auto amp.				
Connector	Terminal			
M50	32	Ground	Blower speed: 1st (Blower motor operating)	10 V

Is the inspection result normal?

YES >> Replace auto amp.

NO >> Repair harness or connector.

7. CHECK POWER VOLTAGE OF BLOWER RELAY

1. Turn ignition switch OFF.
2. Remove blower relay.
3. Turn ignition switch ON.
4. Check voltage between rear blower relay connector terminals and ground.

(+)		(-)	Voltage (Approx.)
Rear blower relay			
Connector	Terminal		
M108	1	Ground	Battery voltage
	3		
	6		

Is the inspection result normal?

YES >> Check rear blower motor relay. Refer to [HAC-143, "Component Inspection \(Rear Blower Motor Relay\)"](#).

NO >> Repair harness or connector.

8. CHECK CIRCUIT CONTINUITY BETWEEN BLOWER MOTOR AND REAR BLOWER MOTOR RESISTOR

1. Turn ignition switch OFF.
2. Disconnect rear blower motor resistor 2 connector.
3. Check continuity between blower motor harness connector and rear blower motor resistor 2 harness connector.

REAR BLOWER MOTOR

< DTC/CIRCUIT DIAGNOSIS >

[AUTOMATIC AIR CONDITIONING]

Blower motor		Rear blower motor resistor 2		Continuity
Connector	Terminal	Connector	Terminal	
B134	2	B133	1	Yes

Is the inspection result normal?

YES >> Replace blower motor.

NO >> Repair harness or connector.

9.CHECK REAR BLOWER MOTOR RESISTOR 2

Check rear blower motor resistor 2. Refer to [HAC-143, "Component Inspection \(Rear Blower Motor Resistor\)"](#).

Is the inspection result normal?

YES >> Replace auto amp.

NO >> Replace rear blower motor resistor 2.

Component Inspection (Rear Blower Motor)

INFOID:000000008901789

1.CHECK FRONT BLOWER MOTOR

1. Connect battery voltage to terminal 1 of front blower motor.
2. Connect ground to terminal 2 of front blower motor.

Does the front blower fan operate?

YES >> Intermittent incident. Refer to [GI-49, "Intermittent Incident"](#).

NO >> Replace front blower motor. Refer to [VTL-19, "FRONT BLOWER MOTOR : Removal and Installation"](#).

Component Inspection (Rear Blower Motor Relay)

INFOID:000000008901790

1.CHECK REAR BLOWER RELAY

1. Remove rear blower relay. Refer to [PG-81, "Terminal Arrangement"](#).
2. Check continuity between rear blower relay terminals 3 and 5, then 6 and 7 when voltage is supplied between terminals 1 and 2.

Terminal		Voltage	Continuity
3	5	ON	Yes
		OFF	No
6	7	ON	Yes
		OFF	No

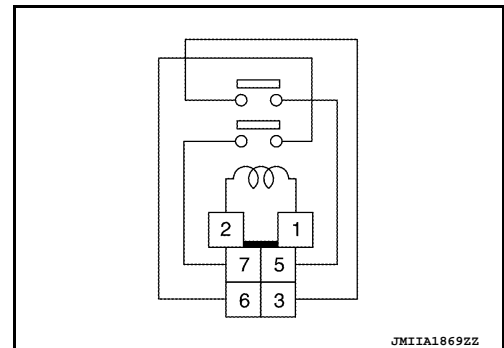

Is the inspection result normal?

YES >> Inspection End.

NO >> Replace rear blower relay.

Component Inspection (Rear Blower Motor Resistor)

INFOID:000000008901791

1.CHECK FAN CONTROL AMP.

1. Turn ignition switch OFF.
2. Remove rear blower motor resistor. Refer to [HAC-166, "Removal and Installation"](#).
3. Check continuity between the rear blower motor resistor terminals using analog circuit tester.

Terminal		Continuity
(+)	(-)	
3	2	Yes
2	3	No

Is the inspection result normal?

REAR BLOWER MOTOR

< DTC/CIRCUIT DIAGNOSIS >

[AUTOMATIC AIR CONDITIONING]

- YES >> Inspection End.
- NO >> Replace rear blower motor resistor.

FRONT AUTOMATIC AIR CONDITIONING SYSTEM

< SYMPTOM DIAGNOSIS >

[AUTOMATIC AIR CONDITIONING]

SYMPTOM DIAGNOSIS

FRONT AUTOMATIC AIR CONDITIONING SYSTEM

Diagnosis Chart By Symptom

INFOID:000000008901712

NOTE:

Perform the self-diagnoses with CONSULT before performing the symptom diagnosis. If DTC is detected, perform the corresponding diagnosis.

Symptom	Corresponding malfunction part	Reference
<ul style="list-style-type: none"> Front air conditioning does not activate. Front air conditioning cannot be controlled. Operation status of air conditioning is not indicated on display. 	<ul style="list-style-type: none"> A/C auto amp. ignition power supply circuit Front A/C control (A/C auto amp.) 	HAC-113, "A/C AUTO AMP. : Diagnosis Procedure"
<ul style="list-style-type: none"> Air outlet does not change. Mode door motor (front) does not operate normally. 	<ul style="list-style-type: none"> Circuit between mode door motor (front) and A/C auto amp. Mode door motor (front) control linkage Mode door motor (front) A/C auto amp. 	HAC-116, "MODE DOOR MOTOR (FRONT) : Diagnosis Procedure"
<ul style="list-style-type: none"> Discharge air temperature of driver side does not change. Air mix door motor (driver side) does not operate normally. 	<ul style="list-style-type: none"> Circuit between air mix door motor (driver side) and A/C auto amp. Air mix door motor (driver side) installation condition Air mix door motor (driver side) A/C auto amp. 	HAC-113, "AIR MIX DOOR MOTOR (DRIVER SIDE) : Diagnosis Procedure"
<ul style="list-style-type: none"> Discharge air temperature of passenger side does not change. Air mix door motor (passenger side) does not operate normally. 	<ul style="list-style-type: none"> Circuit between air mix door motor (passenger side) and A/C auto amp. Air mix door motor (passenger side) installation condition Air mix door motor (passenger side) A/C auto amp. 	HAC-114, "AIR MIX DOOR MOTOR (PASSENGER SIDE) : Diagnosis Procedure"
<ul style="list-style-type: none"> Intake door does not change. Intake door motor does not operate normally. 	<ul style="list-style-type: none"> Circuit between intake door motor and A/C auto amp. Intake door motor control linkage Intake door motor A/C auto amp. 	HAC-118, "INTAKE DOOR MOTOR : Diagnosis Procedure"
All door motors do not operate normally.	<ul style="list-style-type: none"> Each door motor power supply and ground circuit A/C auto amp. 	HAC-127, "Diagnosis Procedure"
Front blower motor operation is malfunctioning.	<ul style="list-style-type: none"> Power supply system of front blower motor Circuit between front blower motor and A/C auto amp. Front blower motor A/C auto amp. 	HAC-131, "Diagnosis Procedure"
Compressor does not operate.	<ul style="list-style-type: none"> Circuit between magnet clutch and IPDM E/R Magnet clutch IPDM E/R (A/C relay) Circuit between ECM and refrigerant pressure sensor Refrigerant pressure sensor CAN communication circuit A/C auto amp. 	HAC-134, "Diagnosis Procedure"

A
B
C
D
E
F
G
H
J
K
L
M
N
O
P

HAC

FRONT AUTOMATIC AIR CONDITIONING SYSTEM

< SYMPTOM DIAGNOSIS >

[AUTOMATIC AIR CONDITIONING]

Symptom	Corresponding malfunction part	Reference	
<ul style="list-style-type: none"> • Insufficient cooling. • No cool air comes out. (Air flow volume is normal.) 	<ul style="list-style-type: none"> • Magnet clutch control system • Drive belt slipping • Refrigerant cycle • Air leakage from each duct • A/C auto amp. connection recognition signal circuit • Temperature setting trimmer (front) 	HAC-148, "FRONT AIR CONDITIONER : Diagnosis Procedure"	
<ul style="list-style-type: none"> • Insufficient heating. • No warm air comes out. (Air flow volume is normal.) 	<ul style="list-style-type: none"> • Engine cooling system • Heater hose • Heater core • Air leakage from each duct • Temperature setting trimmer (front) 	HAC-150, "FRONT AIR CONDITIONER : Diagnosis Procedure"	
Noise is heard when front air conditioning system operates.	During compressor operation	Refrigerant cycle	HA-18, "Symptom Table"
	During front blower motor operation	<ul style="list-style-type: none"> • Mixing any foreign object in front blower motor • Front blower motor fan breakage • Front blower motor rotation inferiority 	HAC-132, "Component Inspection (Front Blower Motor)"
<ul style="list-style-type: none"> • Memory function does not operate. • Setting temperature is not memorized. 	<ul style="list-style-type: none"> • Battery power supply system of A/C auto amp. • A/C auto amp. 	HAC-113, "A/C AUTO AMP. : Diagnosis Procedure"	
Intelligent Key interlock function does not operate.	<ul style="list-style-type: none"> • Door lock system • CAN communication circuit • A/C auto amp. 	HAC-152, "Diagnosis Procedure"	

REAR AUTOMATIC AIR CONDITIONING SYSTEM

< SYMPTOM DIAGNOSIS >

[AUTOMATIC AIR CONDITIONING]

REAR AUTOMATIC AIR CONDITIONING SYSTEM

Diagnosis Chart By Symptom

INFOID:000000008901713

NOTE:

- Perform the self-diagnoses with CONSULT before performing the symptom diagnosis. If DTC is detected, perform the corresponding diagnosis.
- The following table is based on the condition that front automatic air conditioning system operates normally.

Symptom		Corresponding malfunction part	Reference
<ul style="list-style-type: none"> • Rear air conditioning cannot be controlled by front A/C control. • Operation status of rear air conditioning is not indicated on front A/C control display. 		A/C auto amp.	Replace A/C auto amp. Refer to HAC-156, "Removal and Installation" .
Rear air conditioning cannot be controlled by rear air control.	Operation status of rear air conditioning is indicated on rear air control display.	Communication signal (rear air control → A/C auto amp.)	Refer to HAC-110, "Diagnosis Procedure" .
	Operation status of rear air conditioning is not indicated on rear air control display.	Communication signal (A/C auto amp. → rear air control) Rear air control power supply circuit	Refer to HAC-110, "Diagnosis Procedure" . Refer to HAC-122, "REAR A/C CONTROL : Diagnosis Procedure" .
<ul style="list-style-type: none"> • Air outlet does not change. • Mode door motor (rear) does not operate normally. 		<ul style="list-style-type: none"> • Circuit between mode door motor (rear) and A/C auto amp. • Mode door motor (rear) control linkage • Mode door motor (rear) • A/C auto amp. 	HAC-117, "MODE DOOR MOTOR (REAR) : Diagnosis Procedure"
<ul style="list-style-type: none"> • Discharge air temperature does not change. • Air mix door motor (rear) does not operate normally. 		<ul style="list-style-type: none"> • Circuit between air mix door motor (rear) and A/C auto amp. • Air mix door motor (rear) installation condition • Air mix door motor (rear) • A/C auto amp. 	HAC-115, "AIR MIX DOOR MOTOR (REAR) : Diagnosis Procedure"
Rear blower motor operation is malfunctioning.		<ul style="list-style-type: none"> • Power supply system of rear blower motor • Circuit between rear blower motor and A/C auto amp. • Rear blower motor • A/C auto amp. 	HAC-139, "Diagnosis Procedure"
<ul style="list-style-type: none"> • Insufficient cooling. • No cool air comes out. (Air flow volume is normal.) 		<ul style="list-style-type: none"> • A/C auto amp. • Refrigerant cycle • Air leakage from each duct • Temperature setting trimmer (rear) 	HAC-113, "A/C AUTO AMP. : Diagnosis Procedure"
<ul style="list-style-type: none"> • Insufficient heating. • No warm air comes out. (Air flow volume is normal.) 		<ul style="list-style-type: none"> • PTC heater • Air leakage from each duct • Temperature setting trimmer (rear) 	HAC-137, "Diagnosis Procedure"
Noise is heard when rear blower motor operates.		<ul style="list-style-type: none"> • Mixing any foreign object in rear blower motor • Rear blower motor fan breakage • Rear blower motor rotation inferiority 	HAC-143, "Component Inspection (Rear Blower Motor)"

A
B
C
D
E
F
G
H
I
J
K
L
M
N
O
P

HAC

INSUFFICIENT COOLING

[AUTOMATIC AIR CONDITIONING]

< SYMPTOM DIAGNOSIS >

INSUFFICIENT COOLING FRONT AIR CONDITIONER

FRONT AIR CONDITIONER : Description

INFOID:000000008901715

Symptom

- Insufficient cooling
- No cool air comes out. (Air flow volume is normal.)

FRONT AIR CONDITIONER : Diagnosis Procedure

INFOID:000000008901716

NOTE:

Perform self-diagnoses with CONSULT before performing symptom diagnosis. If any DTC is detected, perform the corresponding diagnosis.

1.CHECK MAGNET CLUTCH OPERATION

1. Turn ignition switch ON.
2. Operate fan switch.
3. Press A/C switch.
4. Check that A/C indicator turns ON. Check visually and by sound that compressor operates.
5. Press A/C switch again.
6. Check that A/C indicator turns OFF. Check that compressor stops.

Is the inspection result normal?

YES >> GO TO 2.

NO >> Perform diagnosis of "COMPRESSOR DOES NOT OPERATE" in "SYMPTOM DIAGNOSIS".
Refer to [HAC-153, "Diagnosis Procedure"](#).

2.CHECK DRIVE BELT

Check tension of drive belt. Refer to [EM-12, "Checking Drive Belt"](#).

Is the inspection result normal?

YES >> GO TO 3.

NO >> Adjust or replace drive belt depending on the inspection results.

3.CHECK REFRIGERANT CYCLE

Connect recovery/recycling recharging equipment to the vehicle and perform pressure inspection with gauge. Refer to [HA-18, "Symptom Table"](#).

Is the inspection result normal?

YES >> GO TO 4.

NO >> Repair or replace parts depending on the inspection results.

4.CHECK AIR LEAKAGE FROM EACH DUCT

Check duct and nozzle, etc. of the front air conditioning system for leakage.

Is the inspection result normal?

YES >> GO TO 5.

NO >> Repair or replace parts depending on the inspection results.

5.CHECK AMBIENT TEMPERATURE DISPLAY

Check that there is not much difference between actual ambient temperature and indicated temperature on information display in combination meter.

Is the inspection result normal?

YES >> GO TO 6.

NO >> Perform diagnosis for the A/C auto amp. connection recognition signal circuit. Refer to [HAC-87, "Diagnosis Procedure"](#).

6.CHECK SETTING OF TEMPERATURE SETTING TRIMMER (FRONT)

1. Check setting value of temperature setting trimmer (front). Refer to [HAC-79, "FRONT AUTOMATIC AIR CONDITIONING SYSTEM : Temperature Setting Trimmer \(Front\)"](#).
2. Check that temperature setting trimmer (front) is set to "+ direction".

INSUFFICIENT COOLING

[AUTOMATIC AIR CONDITIONING]

< SYMPTOM DIAGNOSIS >

NOTE:

The control temperature can be set with the setting of the temperature setting trimmer (front).

3. Set difference between set temperature and control temperature to "0".

Is inspection result normal?

YES >> Inspection End.

NO >> Replace A/C auto amp. Refer to [HAC-156. "Removal and Installation"](#).

REAR AIR CONDITIONER

REAR AIR CONDITIONER : Description

INFOID:000000008901717

Symptom

- Insufficient cooling
- No cool air comes out. (Air flow volume is normal.)

REAR AIR CONDITIONER : Diagnosis Procedure

INFOID:000000008901718

NOTE:

Perform self-diagnoses with CONSULT before performing symptom diagnosis. If any DTC is detected, perform the corresponding diagnosis.

1.CHECK REFRIGERANT CYCLE

Connect recovery/recycling recharging equipment to the vehicle and perform pressure inspection with gauge. Refer to [HA-18. "Symptom Table"](#).

Is the inspection result normal?

YES >> GO TO 2.

NO >> Repair or replace parts depending on the inspection results.

2.CHECK AIR LEAKAGE FROM EACH DUCT

Check duct and nozzle, etc. of the rear air conditioning system for leakage.

Is the inspection result normal?

YES >> GO TO 3.

NO >> Repair or replace parts depending on the inspection results.

3.CHECK SETTING OF TEMPERATURE SETTING TRIMMER (REAR)

1. Check setting value of temperature setting trimmer (rear). Refer to [HAC-80. "REAR AUTOMATIC AIR CONDITIONING SYSTEM : Temperature Setting Trimmer \(Rear\)"](#).
2. Check that temperature setting trimmer (rear) is set to "+ direction".

NOTE:

The control temperature can be set with the setting of the temperature setting trimmer (rear).

3. Set difference between set temperature and control temperature to "0".

Is inspection result normal?

YES >> Inspection End.

NO >> Replace A/C auto amp. Refer to [HAC-156. "Removal and Installation"](#).

INSUFFICIENT HEATING

[AUTOMATIC AIR CONDITIONING]

< SYMPTOM DIAGNOSIS >

INSUFFICIENT HEATING FRONT AIR CONDITIONER

FRONT AIR CONDITIONER : Description

INFOID:000000008901719

Symptom

- Insufficient heating
- No warm air comes out. (Air flow volume is normal.)

FRONT AIR CONDITIONER : Diagnosis Procedure

INFOID:000000008901720

NOTE:

Perform self-diagnoses with on board diagnosis and CONSULT before performing symptom diagnosis. If DTC is detected, perform the corresponding diagnosis.

1. CHECK COOLING SYSTEM

1. Check engine coolant level and check leakage. Refer to [CO-10. "System Inspection"](#).
2. Check reservoir tank cap. Refer to [CO-10. "System Inspection"](#).
3. Check water flow sounds of the engine coolant. Refer to [CO-10. "System Inspection"](#).

Is the inspection result normal?

YES >> GO TO 2.

NO >> Refill engine coolant and repair or replace parts depending on the inspection results.

2. CHECK HEATER HOSE

Check installation of heater hose visually or by touching.

Is the inspection result normal?

YES >> GO TO 3.

NO >> Repair or replace parts depending on the inspection results.

3. CHECK HEATER CORE

1. Check temperature of inlet hose and outlet hose of front heater core.
2. Check that inlet side of heater core is hot and the outlet side is slightly lower than/almost equal to the inlet side.

CAUTION:

Always perform the temperature inspection in a short period of time because the engine coolant temperature is very hot.

Is the inspection result normal?

YES >> GO TO 4.

NO >> Replace heater core. Refer to [HA-44. "HEATER CORE : Removal and Installation"](#).

4. CHECK AIR LEAKAGE FROM EACH DUCT

Check duct and nozzle, etc. of front air conditioning system for air leakage.

Is the inspection result normal?

YES >> GO TO 5.

NO >> Repair or replace parts depending on the inspection results.

5. CHECK SETTING OF TEMPERATURE SETTING TRIMMER (FRONT)

1. Check setting value of temperature setting trimmer (front). Refer to [HAC-79. "FRONT AUTOMATIC AIR CONDITIONING SYSTEM : Temperature Setting Trimmer \(Front\)"](#).
2. Check that temperature setting trimmer (front) is set to "– direction".

NOTE:

The control temperature can be set by the temperature setting trimmer (front).

3. Set difference between the set temperature and control temperature to "0".

Are the symptoms solved?

YES >> Inspection End.

NO >> Replace A/C auto amp. Refer to [HAC-156. "Removal and Installation"](#).

REAR AIR CONDITIONER

INSUFFICIENT HEATING

< SYMPTOM DIAGNOSIS >

[AUTOMATIC AIR CONDITIONING]

REAR AIR CONDITIONER : Description

INFOID:000000008901721

Symptom

- Insufficient heating
- No warm air comes out. (Air flow volume is normal.)

REAR AIR CONDITIONER : Diagnosis Procedure

INFOID:000000008901722

CAUTION:

Perform the self-diagnoses with on board diagnosis and CONSULT before performing symptom diagnosis. If any malfunction result or DTC is detected, perform the corresponding diagnosis.

1. CHECK PTC HEATER

Check PTC heater. Refer to [HAC-137, "Diagnosis Procedure"](#).

Is the inspection result normal?

YES >> GO TO 2.

NO >> Replace PTC heater. Refer to [HA-49, "Removal and Installation"](#).

2. CHECK AIR LEAKAGE FROM EACH DUCT

Check duct and nozzle, etc. of the rear air conditioning system for air leakage.

Is the inspection result normal?

YES >> GO TO 3.

NO >> Repair or replace parts depending on the inspection results.

3. CHECK SETTING OF TEMPERATURE SETTING TRIMMER (REAR)

1. Check setting value of temperature setting trimmer (rear). Refer to [HAC-80, "REAR AUTOMATIC AIR CONDITIONING SYSTEM : Temperature Setting Trimmer \(Rear\)"](#).

2. Check that the temperature setting trimmer is set to "– direction".

NOTE:

The control temperature can be set by the temperature setting trimmer (rear).

3. Set the difference between the set temperature (rear) and control temperature to "0".

Are the symptoms solved?

YES >> Inspection End.

NO >> Replace A/C auto amp. Refer to [HAC-156, "Removal and Installation"](#).

A
B
C
D
E
F
G
H
J
K
L
M
N
O
P

HAC

INTELLIGENT KEY INTERLOCK FUNCTION DOES NOT OPERATE

< SYMPTOM DIAGNOSIS >

[AUTOMATIC AIR CONDITIONING]

INTELLIGENT KEY INTERLOCK FUNCTION DOES NOT OPERATE

Description

INFOID:000000008901723

Symptom: Intelligent Key interlock function does not operate.

Diagnosis Procedure

INFOID:000000008901724

1.CHECK DOOR LOCK SYSTEM

Check door lock system.

Refer to [DLK-106. "Work Flow"](#).

Is the inspection result normal?

YES >> GO TO 2.

NO >> Repair or replace malfunctioning parts.

2.CHECK INTERMITTENT INCIDENT

Refer to [GI-49. "Intermittent Incident"](#).

Is the inspection result normal?

YES >> Replace A/C auto amp. Refer to [HAC-156. "Removal and Installation"](#).

NO >> Repair or replace malfunctioning parts.

COMPRESSOR DOES NOT OPERATE

< SYMPTOM DIAGNOSIS >

[AUTOMATIC AIR CONDITIONING]

COMPRESSOR DOES NOT OPERATE

Description

INFOID:000000008901725

Symptom: Compressor does not operate.

Diagnosis Procedure

INFOID:000000008901726

NOTE:

- Perform self-diagnoses with CONSULT before performing symptom diagnosis. If DTC is detected, perform the corresponding diagnosis.
- Check that refrigerant system is properly charged. If refrigerant amount is below the proper amount, perform inspection of refrigerant leakage.

1. CHECK MAGNET CLUTCH OPERATION

Check magnet clutch. Refer to [HAC-134, "Component Function Check"](#).

Does it operate normally?

YES >> GO TO 2.

NO >> Repair or replace malfunctioning parts.

2. CHECK REFRIGERANT PRESSURE SENSOR

Check refrigerant pressure sensor. Refer to [EC-442, "Component Function Check"](#).

Is the inspection result normal?

YES >> GO TO 3.

NO >> Repair or replace malfunctioning parts.

3. CHECK A/C AUTO AMP. OUTPUT SIGNAL

 With CONSULT

Check "COMP REQ SIG" and "FAN REQ SIG" in "DATA MONITOR" mode of "HVAC" using CONSULT.

Monitor item	Condition	Status	
COMP REQ SIG	A/C switch	ON	On
		OFF	Off
FAN REQ SIG	Front blower motor	ON	On
		OFF	Off

Is the inspection result normal?

YES >> GO TO 4.

NO >> Replace A/C auto amp. Refer to [HAC-156, "Removal and Installation"](#).

4. CHECK ECM INPUT SIGNAL

 With CONSULT

Check "AIR COND SIG" and "HEATER FAN SW" in "DATA MONITOR" mode of "ECM" using CONSULT.

Monitor item	Condition	Status	
AIR COND SIG	A/C switch	ON	On
		OFF	Off
HEATER FAN SW	Front blower motor	ON	On
		OFF	Off

Is the inspection result normal?

YES >> GO TO 5.

NO >> Check CAN communication system. Refer to [LAN-20, "Trouble Diagnosis Flow Chart"](#).

5. CHECK IPDM E/R INPUT SIGNAL

 With CONSULT

1. Start engine.

A
B
C
D
E
F
G
H
J
K
L
M
N
O
P

HAC

COMPRESSOR DOES NOT OPERATE

< SYMPTOM DIAGNOSIS >

[AUTOMATIC AIR CONDITIONING]

2. Check "AC COMP REQ" in "DATA MONITOR" mode of "IPDM E/R" using CONSULT.

Monitor item	Condition	Status
AC COMP REQ	A/C switch	ON
		OFF

Is the inspection result normal?

YES >> Inspection End.

NO >> Check CAN communication system. Refer to [LAN-20. "Trouble Diagnosis Flow Chart"](#).

REMOVAL AND INSTALLATION

A/C SWITCH

Removal and Installation

INFOID:000000008509339

REMOVAL

1. Remove cluster lid C lower. Refer to [IP-22, "Removal and Installation - Cluster Lid C Lower"](#).
2. Remove the AV and A/C switch assembly screws (A).

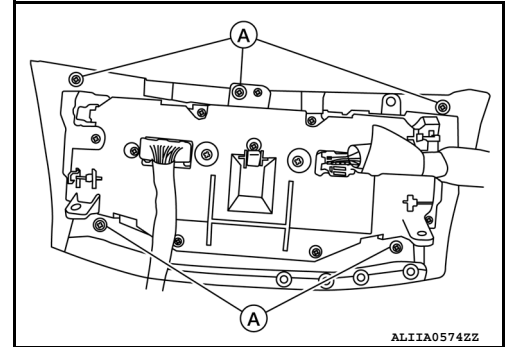

3. Disconnect the harness connectors from the AV and A/C switch assembly and remove.

INSTALLATION

Installation is in the reverse order of removal.

A
B
C
D
E
F
G
H
J
K
L
M
N
O
P

HAC

A/C AUTO AMP.

Exploded View

INFOID:000000008509340

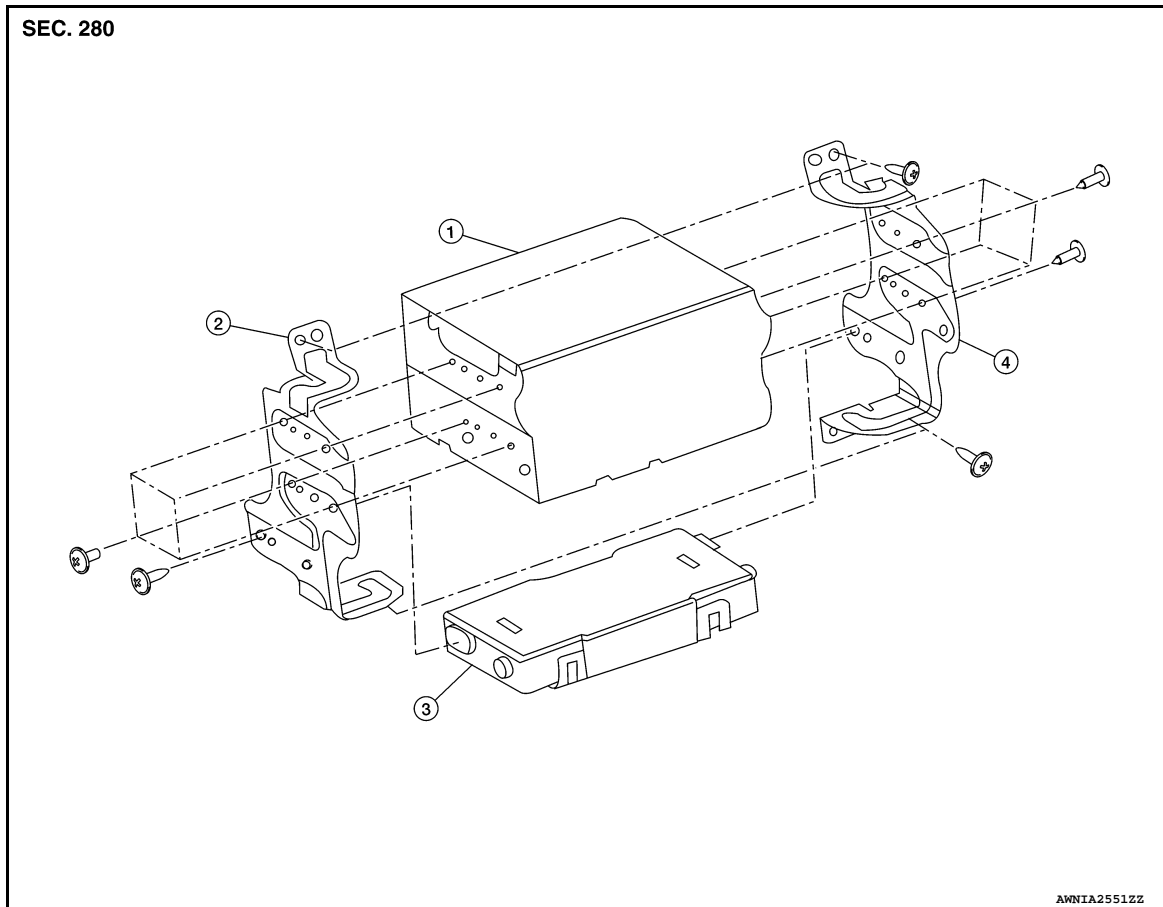

1. A/V control unit
2. AV control unit bracket LH
3. A/C auto amp.
4. AV control unit bracket RH

Removal and Installation

INFOID:000000008509341

REMOVAL

1. Remove the audio unit (BASE AUDIO). Refer to [AV-46. "Removal and Installation"](#)
2. Remove the AV control unit. Refer to [AV-186. "Removal and Installation"](#) (MID AUDIO WITHOUT BOSE), [AV-357. "Removal and Installation"](#) (MID AUDIO WITH BOSE) or [AV-585. "Removal and Installation"](#) (PREMIUM AUDIO WITH NAVIGATION).
3. Remove the screws and the A/C auto amp. brackets (LH/RH).
4. Remove the A/C auto amp.

INSTALLATION

Installation is in the reverse order of removal.

AMBIENT SENSOR

< REMOVAL AND INSTALLATION >

[AUTOMATIC AIR CONDITIONING]

AMBIENT SENSOR

Removal and Installation

INFOID:000000008509342

REMOVAL

1. Remove the core support cover. Refer to [EXT-16. "Exploded View"](#).
2. Disconnect the harness connector from the ambient sensor.
3. Release the ambient sensor clip, then remove the ambient sensor (1).

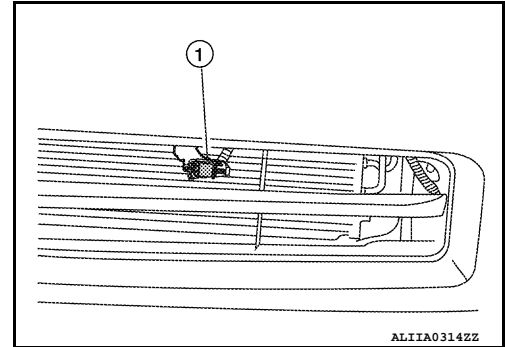

INSTALLATION

Installation is in the reverse order of removal.

A
B
C
D
E
F
G
H
J
K
L
M
N
O
P

HAC

IN-VEHICLE SENSOR

< REMOVAL AND INSTALLATION >

[AUTOMATIC AIR CONDITIONING]

IN-VEHICLE SENSOR

Removal and Installation

INFOID:00000008509343

REMOVAL

1. Remove instrument lower panel LH. Refer to [IP-25. "Removal and Installation"](#).
2. Remove the in-vehicle sensor screw (A), then remove in-vehicle sensor (1).

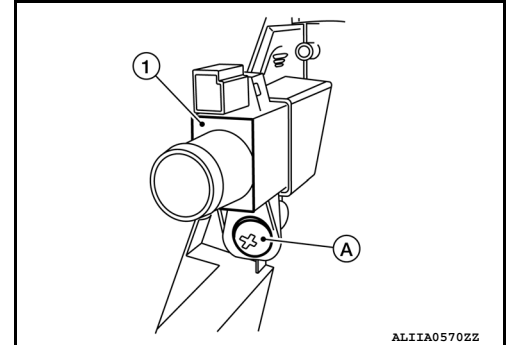

INSTALLATION

Installation is in the reverse order of removal.

CAUTION:

Make sure that the aspirator hose is securely attached to the in-vehicle sensor when installing the instrument lower panel LH.

SUNLOAD SENSOR

< REMOVAL AND INSTALLATION >

[AUTOMATIC AIR CONDITIONING]

SUNLOAD SENSOR

Removal and Installation

INFOID:000000008509344

REMOVAL

1. Remove the instrument panel tweeter grille (LH). Refer to [IP-14. "Exploded View"](#).
2. Disconnect the harness connector from the sunload sensor.
3. Release the pawls, then remove sunload sensor (1) from the instrument panel tweeter grille (LH).

: Pawl

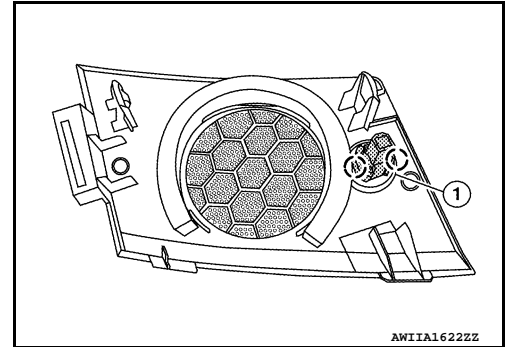

INSTALLATION

Installation is in the reverse order of removal.

A

B

C

D

E

F

G

H

HAC

J

K

L

M

N

O

P

INTAKE SENSOR

< REMOVAL AND INSTALLATION >

[AUTOMATIC AIR CONDITIONING]

INTAKE SENSOR

Removal and Installation

INFOID:000000008509345

REMOVAL

1. Remove the front evaporator. Refer to [HA-45. "EVAPORATOR : Removal and Installation - Front Evaporator"](#).
2. Remove the intake sensor (2) by pulling out of the front evaporator (1).

CAUTION:

- Mark the installed position of the intake sensor.
- Do not damage the evaporator core.

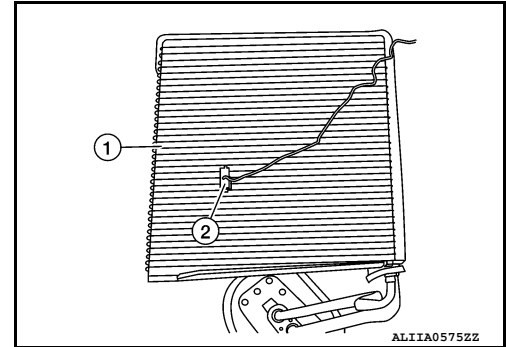

INSTALLATION

Installation is in the reverse order of removal.

CAUTION:

Install the intake sensor in the same position as the original intake sensor on the evaporator core.

REFRIGERANT PRESSURE SENSOR

< REMOVAL AND INSTALLATION >

[AUTOMATIC AIR CONDITIONING]

REFRIGERANT PRESSURE SENSOR

Removal and Installation

INFOID:000000009000812

REMOVAL

1. Discharge the refrigerant. Refer to [HA-23, "Recycle Refrigerant"](#).
2. Remove the radiator core support upper cover. Refer to [HA-38, "Exploded View"](#).
3. Disconnect the harness connector from the refrigerant pressure sensor.
4. Remove the refrigerant pressure sensor (1).

CAUTION:

Cap or wrap the opening of the refrigerant pressure sensor with suitable material such as vinyl tape to avoid the entry of air.

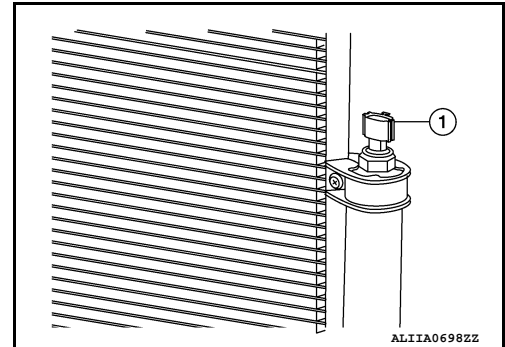

INSTALLATION

Installation is in the reverse order of removal.

CAUTION:

- Do not reuse O-ring.
- Apply A/C oil to the O-ring of the refrigerant pressure sensor for installation.
- After charging the refrigerant, check for leaks. Refer to [HA-21, "Leak Test"](#).

A
B
C
D
E
F
G
H
J
K
L
M
N
O
P

HAC

DOOR MOTOR

< REMOVAL AND INSTALLATION >

[AUTOMATIC AIR CONDITIONING]

DOOR MOTOR

Exploded View

INFOID:00000008509348

Front Door Motors

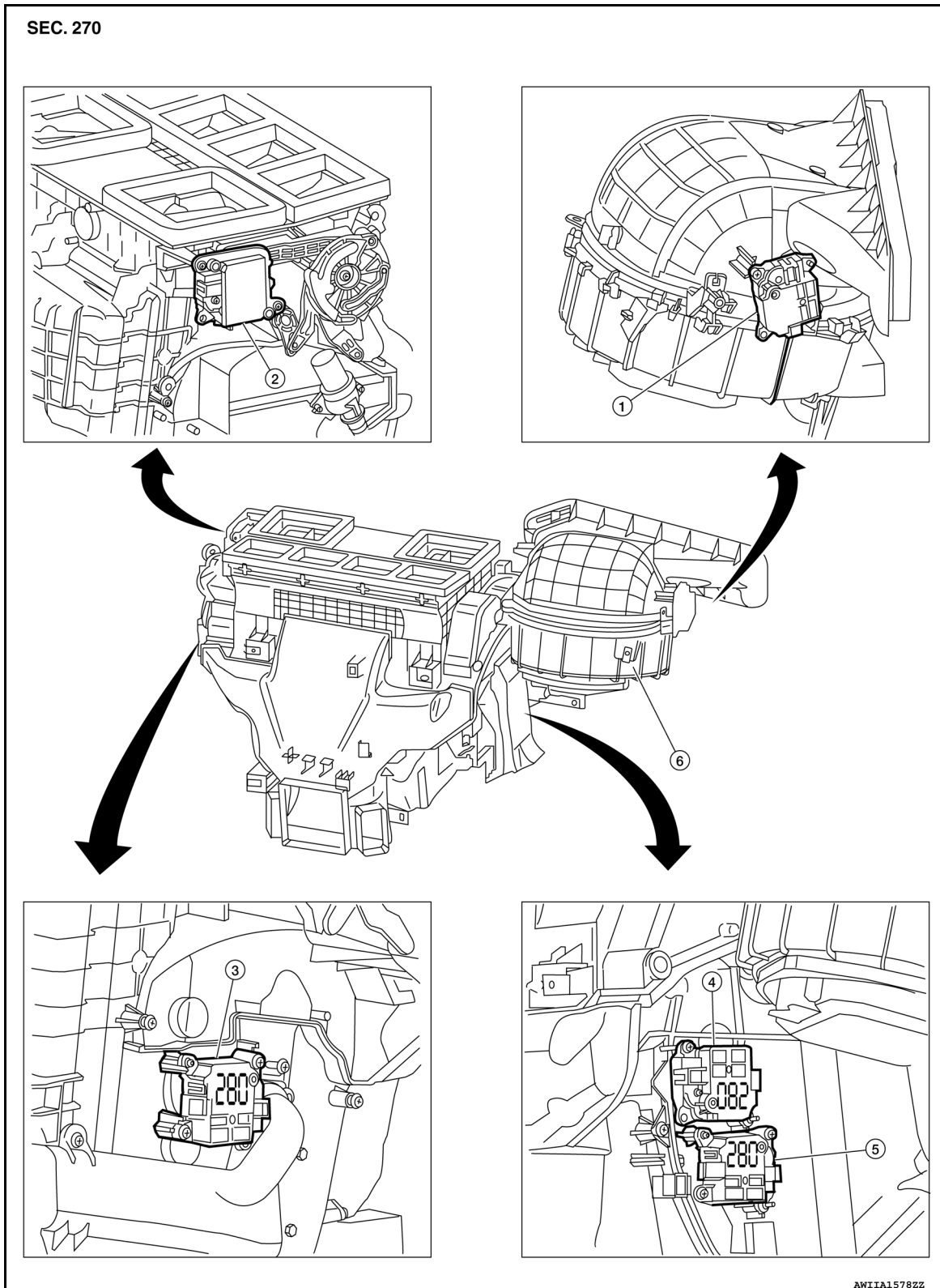

- | | | |
|--|------------------------------|--|
| 1. Intake door motor | 2. Mode door motor (front) | 3. Air mix door motor (driver side) |
| 4. Air mix door motor (passenger side) | 5. Air mix door motor (rear) | 6. Front heating and cooling unit assembly |

DOOR MOTOR

< REMOVAL AND INSTALLATION >

[AUTOMATIC AIR CONDITIONING]

Rear Door Motors

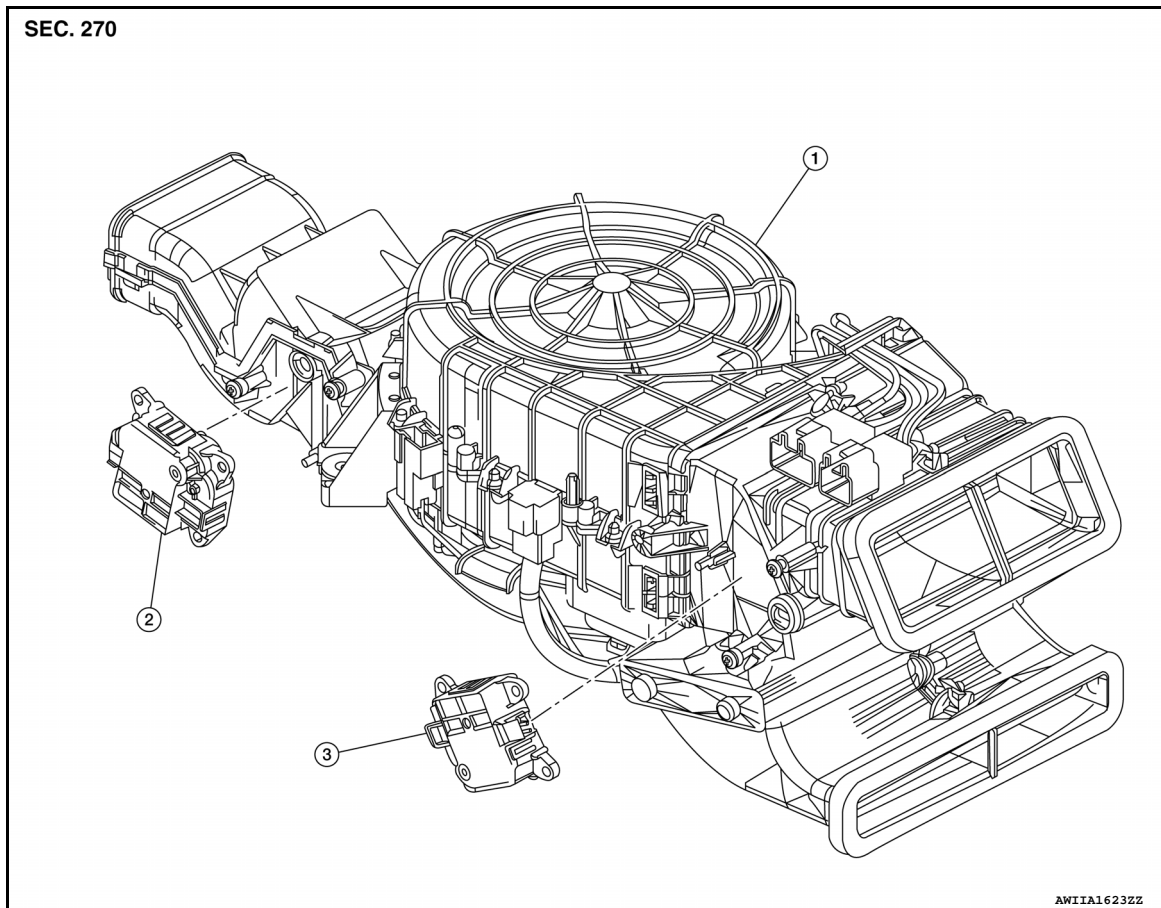

1. Center PTC heating unit 2. Rear shut-off door motor 3. Mode door motor (rear)

MODE DOOR MOTOR

MODE DOOR MOTOR : Removal and Installation - Mode Door Motor (Front)

INFOID:000000008509349

REMOVAL

1. Remove the center console side finisher (LH). Refer to [IP-18, "Exploded View"](#).
2. Remove the front foot duct (LH). Refer to [HA-41, "HEATING AND COOLING UNIT ASSEMBLY : Exploded View - Front Heating and Cooling Unit Assembly"](#).
3. Remove the mode door motor (front) screws.
4. Disconnect the harness connector from the mode door motor (front) and remove.

INSTALLATION

Installation is in the reverse order of removal.

MODE DOOR MOTOR : Removal and Installation - Mode Door Motor (Rear)

INFOID:000000008509350

REMOVAL

1. Remove the center console assembly. Refer to [IP-18, "Removal and Installation"](#).
2. Disconnect the harness connectors from the PTC heater.
3. Remove the screws from the mode door motor (rear).
4. Disconnect the harness connector from the mode door motor (rear) and remove.

INSTALLATION

Installation is in the reverse order of removal.

A
B
C
D
E
F
G
H
J
K
L
M
N
O
P

HAC

DOOR MOTOR

< REMOVAL AND INSTALLATION >

[AUTOMATIC AIR CONDITIONING]

AIR MIX DOOR MOTOR

AIR MIX DOOR MOTOR : Removal and Installation - Air Mix Door Motor (Driver Side)

INFOID:000000008509351

REMOVAL

1. Remove the center console side finisher (LH). Refer to [IP-18, "Exploded View"](#).
2. Remove the front foot duct (LH). Refer to [HA-41, "HEATING AND COOLING UNIT ASSEMBLY : Exploded View - Front Heating and Cooling Unit Assembly"](#).
3. Remove the air mix door motor (driver side) screws.
4. Disconnect the harness connector from the air mix door motor (driver side) and remove.

INSTALLATION

Installation is in the reverse order of removal.

AIR MIX DOOR MOTOR : Removal and Installation - Air Mix Door Motor (Passenger Side)

INFOID:000000008509352

REMOVAL

1. Remove the front foot duct (RH). Refer to [HA-41, "HEATING AND COOLING UNIT ASSEMBLY : Exploded View - Front Heating and Cooling Unit Assembly"](#).
2. Remove the air mix door motor (passenger side) screws.
3. Disconnect the harness connector from the air mix door motor (passenger side) and remove.

INSTALLATION

Installation is in the reverse order of removal.

AIR MIX DOOR MOTOR : Removal and Installation - Air Mix Door Motor (Rear)

INFOID:000000008509353

REMOVAL

1. Remove the glove box assembly. Refer to [IP-26, "Removal and Installation"](#).
2. Remove the front foot duct (RH). Refer to [HA-41, "HEATING AND COOLING UNIT ASSEMBLY : Exploded View - Front Heating and Cooling Unit Assembly"](#).
3. Remove the air mix door motor (rear) screws.
4. Disconnect the harness connector from the air mix door motor (rear) and remove.

INSTALLATION

Installation is in the reverse order of removal.

INTAKE DOOR MOTOR

INTAKE DOOR MOTOR : Removal and Installation

INFOID:000000008509354

REMOVAL

1. Remove the glove box assembly. Refer to [IP-26, "Removal and Installation"](#).
2. Remove the intake door motor screws.
3. Disconnect the harness connector from the intake door motor and remove.

INSTALLATION

Installation is in the reverse order of removal.

REAR SHUT-OFF DOOR MOTOR

REAR SHUT-OFF DOOR MOTOR : Removal and Installation

INFOID:000000008509355

REMOVAL

1. Remove the center console rear brace. Refer to [IP-18, "Exploded View"](#).

DOOR MOTOR

< REMOVAL AND INSTALLATION >

[AUTOMATIC AIR CONDITIONING]

2. Remove the rear shut-off door motor screws.
3. Disconnect the harness connector from the rear shut-off door motor and remove.

INSTALLATION

Installation is in the reverse order of removal.

A

B

C

D

E

F

G

H

HAC

J

K

L

M

N

O

P

BLOWER MOTOR RESISTOR

< REMOVAL AND INSTALLATION >

[AUTOMATIC AIR CONDITIONING]

BLOWER MOTOR RESISTOR

Removal and Installation

INFOID:000000008509356

REMOVAL

1. Remove the luggage side lower finisher (RH). Refer to [INT-28. "LUGGAGE SIDE LOWER FINISHER : Removal and Installation"](#).
2. Disconnect the harness connector from the blower motor resistor.
3. Remove the blower motor resistor screws and remove.

INSTALLATION

Installation is in the reverse order of removal.

IONIZER

< REMOVAL AND INSTALLATION >

[AUTOMATIC AIR CONDITIONING]

IONIZER

Exploded View

INFOID:000000008931690

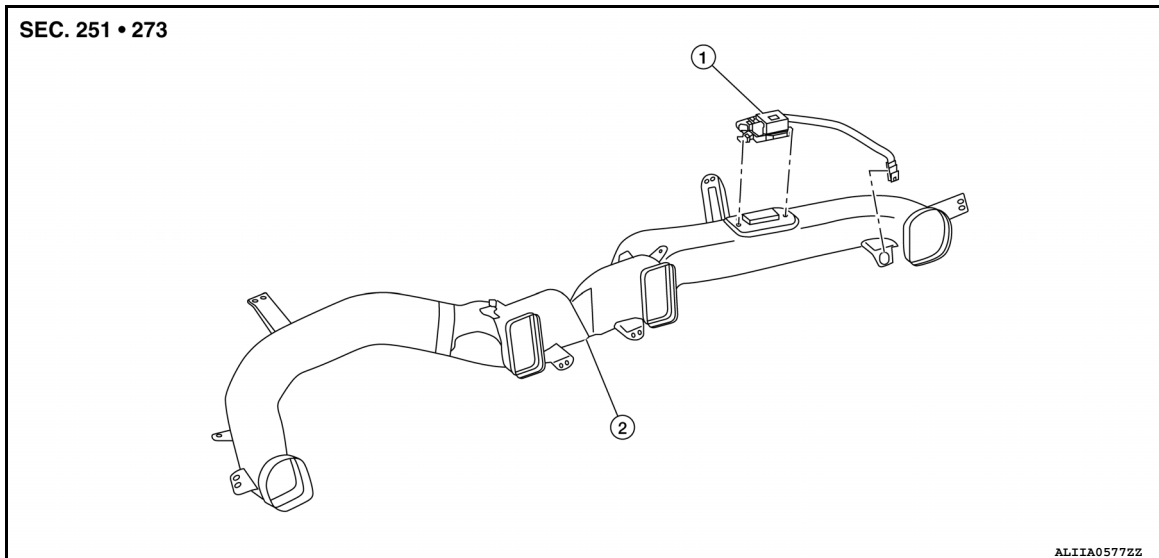

1. Ionizer
2. Center ventilator duct

Removal and Installation

INFOID:000000008931691

Removal

1. Remove instrument panel assembly. Refer to [IP-15. "Removal and Installation"](#).
2. Disconnect the harness connector from the ionizer.
3. Release the ionizer clips, then remove ionizer from the center ventilator duct.

INSTALLATION

Installation is in the reverse order of removal.

CAUTION:

- If there is dirt, use a clean cloth and clean the discharge electrode (ceramic part) of the ionizer.
- Do not touch the surface (ceramic part) of the ionizer, it is the discharge electrode.

A
B
C
D
E
F
G
H
HAC
J
K
L
M
N
O
P