

SECTION **INT**
INTERIOR

A
B
C

CONTENTS

D
E

PRECAUTION	3	CENTER PILLAR UPPER FINISHER : Removal and Installation	18	F
PRECAUTIONS	3	CENTER PILLAR LOWER FINISHER	19	G
Precaution for Supplemental Restraint System (SRS) "AIR BAG" and "SEAT BELT PRE-TENSIONER"	3	CENTER PILLAR LOWER FINISHER : Removal and Installation	19	
Precaution for Work	3	BODY SIDE WELT	19	H
PREPARATION	4	BODY SIDE WELT : Removal and Installation - Front Door Welt	19	
PREPARATION	4	BODY SIDE WELT : Removal and Installation - Rear Door Welt	19	I
Special Service Tool	4	KICKING PLATE	20	
Commercial Service Tools	4	KICKING PLATE : Removal and Installation - Front Kicking Plate	20	INT
CLIP LIST	5	KICKING PLATE : Removal and Installation - Rear Kicking Plate	20	K
Descriptions for Clips	5	FLOOR TRIM	21	
SYMPTOM DIAGNOSIS	9	Exploded View	21	L
SQUEAK AND RATTLE TROUBLE DIAGNOSES	9	Removal and Installation	21	
Work Flow	9	HEADLINING	23	M
Generic Squeak and Rattle Troubleshooting	11	Exploded View	23	
Diagnostic Worksheet	13	Removal and Installation	24	
REMOVAL AND INSTALLATION	15	LUGGAGE FLOOR TRIM	27	N
FRONT DOOR FINISHER	15	Exploded View	27	
Exploded View	15	REAR PILLAR FINISHER	27	O
Removal and Installation	15	REAR PILLAR FINISHER : Removal and Installation	27	
REAR DOOR FINISHER	16	LUGGAGE SIDE LOWER FINISHER	28	P
Exploded View	16	LUGGAGE SIDE LOWER FINISHER : Removal and Installation	28	
Removal and Installation	16	LUGGAGE SIDE UPPER FINISHER	28	
BODY SIDE TRIM	17	LUGGAGE SIDE UPPER FINISHER : Removal and Installation	29	
Exploded View	17	BACK PILLAR FINISHER	29	
FRONT PILLAR FINISHER	17			
FRONT PILLAR FINISHER : Removal and Installation	17			
CENTER PILLAR UPPER FINISHER	18			

BACK PILLAR FINISHER : Removal and Installation	29	BACK DOOR UPPER FINISHER : Removal and Installation	31
STORAGE BOX	30	BACK DOOR SIDE FINISHER	32
STORAGE BOX : Removal and Installation	30	BACK DOOR SIDE FINISHER : Removal and Installation	32
STORAGE BOX SIDE FINISHER	30	BACK DOOR LOWER FINISHER	32
STORAGE BOX SIDE FINISHER : Removal and Installation	30	BACK DOOR LOWER FINISHER : Removal and Installation	32
BACK DOOR TRIM	31	BACK DOOR KICKING PLATE	33
Exploded View	31	BACK DOOR KICKING PLATE : Removal and Installation	33
BACK DOOR UPPER FINISHER	31		

PRECAUTIONS

< PRECAUTION >

PRECAUTION

PRECAUTIONS

Precaution for Supplemental Restraint System (SRS) "AIR BAG" and "SEAT BELT PRE-TENSIONER"

INFOID:000000009020426

The Supplemental Restraint System such as "AIR BAG" and "SEAT BELT PRE-TENSIONER", used along with a front seat belt, helps to reduce the risk or severity of injury to the driver and front passenger for certain types of collision. Information necessary to service the system safely is included in the SR and SB section of this Service Manual.

WARNING:

- To avoid rendering the SRS inoperative, which could increase the risk of personal injury or death in the event of a collision which would result in air bag inflation, all maintenance must be performed by an authorized NISSAN/INFINITI dealer.
- Improper maintenance, including incorrect removal and installation of the SRS, can lead to personal injury caused by unintentional activation of the system. For removal of Spiral Cable and Air Bag Module, see the SR section.
- Do not use electrical test equipment on any circuit related to the SRS unless instructed to in this Service Manual. SRS wiring harnesses can be identified by yellow and/or orange harnesses or harness connectors.

PRECAUTIONS WHEN USING POWER TOOLS (AIR OR ELECTRIC) AND HAMMERS

WARNING:

- When working near the Airbag Diagnosis Sensor Unit or other Airbag System sensors with the Ignition ON or engine running, DO NOT use air or electric power tools or strike near the sensor(s) with a hammer. Heavy vibration could activate the sensor(s) and deploy the air bag(s), possibly causing serious injury.
- When using air or electric power tools or hammers, always switch the Ignition OFF, disconnect the battery and wait at least 3 minutes before performing any service.

Precaution for Work

INFOID:000000009020427

- When removing or disassembling each component, be careful not to damage or deform it. If a component may be subject to interference, be sure to protect it with a shop cloth.
- When removing (disengaging) components with a screwdriver or similar tool, be sure to wrap the component with a shop cloth or vinyl tape to protect it.
- Protect the removed parts with a shop cloth and prevent them from being dropped.
- Replace a deformed or damaged clip.
- If a part is specified as a non-reusable part, always replace it with a new one.
- Be sure to tighten bolts and nuts securely to the specified torque.
- After installation is complete, be sure to check that each part works properly.
- Follow the steps below to clean components:
 - Water soluble dirt:
 - Dip a soft cloth into lukewarm water, wring the water out of the cloth and wipe the dirty area.
 - Then rub with a soft, dry cloth.
 - Oily dirt:
 - Dip a soft cloth into lukewarm water with mild detergent (concentration: within 2 to 3%) and wipe the dirty area.
 - Then dip a cloth into fresh water, wring the water out of the cloth and wipe the detergent off.
 - Then rub with a soft, dry cloth.
 - Do not use organic solvent such as thinner, benzene, alcohol or gasoline.
 - For genuine leather seats, use a genuine leather seat cleaner.

PREPARATION

< PREPARATION >

PREPARATION

PREPARATION

Special Service Tool

INFOID:000000008507093

The actual shapes of Kent-Moore tools may differ from those of special service tools illustrated here.

Tool number (Kent-Moore No.) Tool name	Description
— (J-39570) Chassis ear	Locating the noise
— (J-43980) NISSAN Squeak and Rattle Kit	Repairing the cause of noise
— (J-46534) Trim tool set	Removing trim components

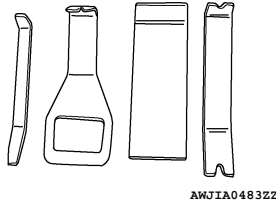
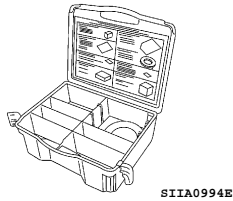
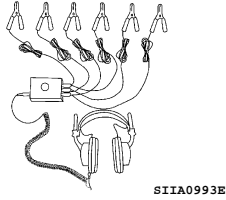

Commercial Service Tools

INFOID:000000008507094

(Kent-Moore No.) Tool name	Description
(J-39565) Engine ear	Locating the noise
(—) Power tools	Loosening nuts, screws and bolts

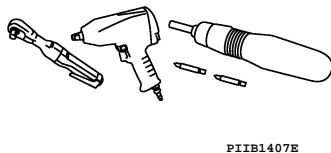
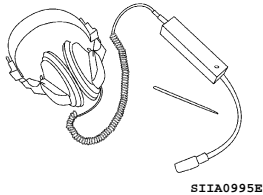

CLIP LIST







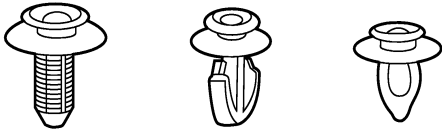

< PREPARATION >

CLIP LIST

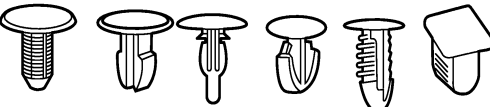
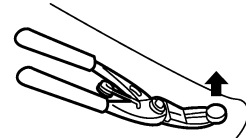
Descriptions for Clips

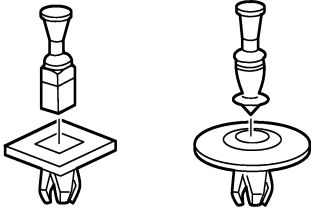
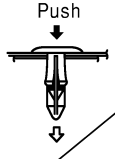
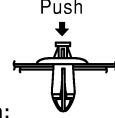
INFOID:000000008507095

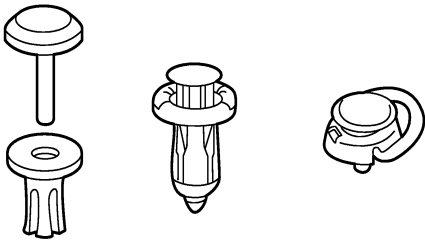
Replace any clips which are damaged during removal or installation.

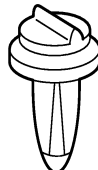
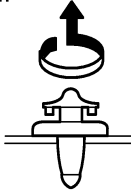







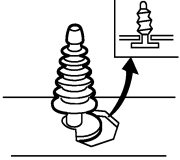
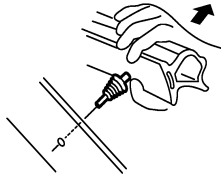

Symbol No.	Shapes	Removal & Installation
C101 		<p>Removal: Remove by bending up with flat-bladed screwdrivers or clip remover.</p> 
C103 		 <p>Removal: Remove with a clip remover.</p>
C203 		<p>Removal: Push center pin to catching position. (Do not remove center pin by hitting it.)</p> <p>Push</p>  <p>Installation:</p> <p>Push</p> 
C205 		<p>Removal: Flat-bladed screwdriver</p>  <p>Clip</p> <p>Finisher</p>
C206 		<p>Removal:</p> 

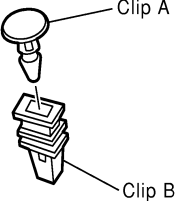
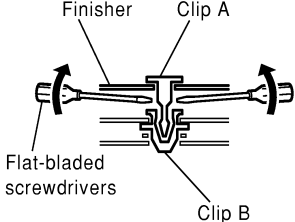
SIIA0315E

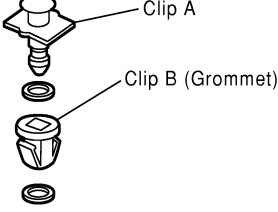
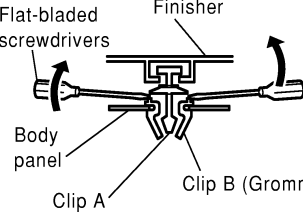
A
B
C
D
E
F
G
H
I
INT
K
L
M
N
O
P

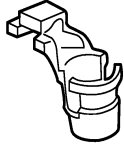
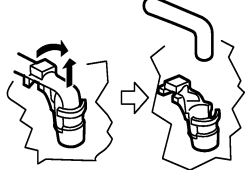
CLIP LIST

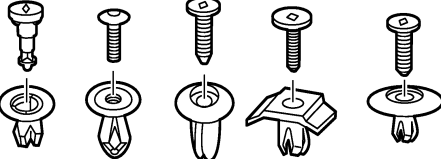









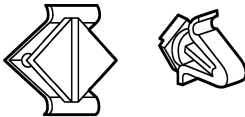

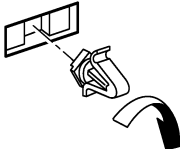
< PREPARATION >

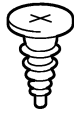
Symbol No.	Shapes	Removal & Installation
<p>CE103</p> 		<p>Removal:</p> 
<p>CF110</p> 		<p>Removal:</p> 
<p>CF118</p> 		<p>Removal:</p> 
<p>CR103</p> 		<p>Removal: Holder portion of clip must be spread out to remove rod.</p> 
<p>CS101</p> 		<p>Removal:</p> <ol style="list-style-type: none"> 1. Screw out with a Phillips screwdriver. 2. Remove female portion with flat-bladed screwdriver. 

SIIA0316E

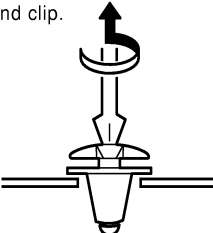
CLIP LIST

< PREPARATION >





Symbol No.	Shapes	Removal & Installation	
CG101 		Removal:  Rotate 45° to remove	Installation: 
CS102 			
CS113 		Removal: Disconnect upper connection of clip with a flat-bladed screwdriver, then remove clip while inserting a flat-bladed screwdriver between body panel and clip. 	
C111 			

SIIA0317E

A
B
C
D
E
F
G
H
I
INT
K
L
M
N
O
P

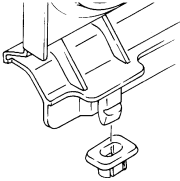
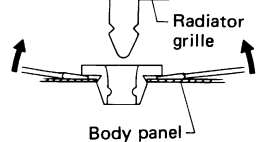
CLIP LIST

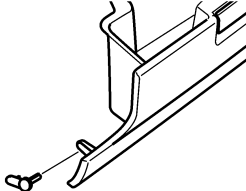
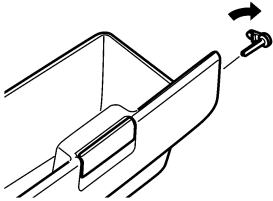
< PREPARATION >

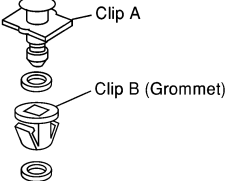
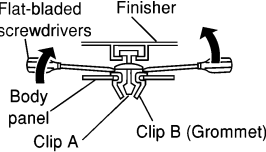
Symbol No.	Shapes	Removal & Installation
<p>CG104</p> 		<p>Removal: Remove by bending up with flat-bladed screwdrivers.</p> 
<p>CE114</p> 		
<p>CF118</p> 		<p>Removal: Flat-bladed screwdrivers Finisher</p> 

ALJIA0564GB

SQUEAK AND RATTLE TROUBLE DIAGNOSES

< SYMPTOM DIAGNOSIS >

SYMPTOM DIAGNOSIS

SQUEAK AND RATTLE TROUBLE DIAGNOSES

Work Flow

INFOID:000000009020419

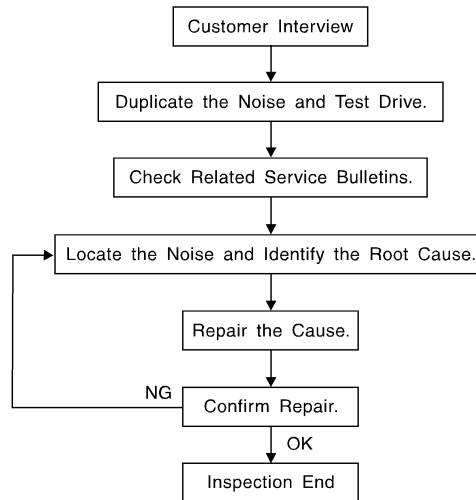

SBT842

CUSTOMER INTERVIEW

Interview the customer if possible, to determine the conditions that exist when the noise occurs. Use the Diagnostic Worksheet during the interview to document the facts and conditions when the noise occurs and any customer's comments; refer to [INT-13, "Diagnostic Worksheet"](#). This information is necessary to duplicate the conditions that exist when the noise occurs.

- The customer may not be able to provide a detailed description or the location of the noise. Attempt to obtain all the facts and conditions that exist when the noise occurs (or does not occur).
- If there is more than one noise in the vehicle, be sure to diagnose and repair the noise that the customer is concerned about. This can be accomplished by test driving the vehicle with the customer.
- After identifying the type of noise, isolate the noise in terms of its characteristics. The noise characteristics are provided so the customer, service adviser and technician are all speaking the same language when defining the noise.
- Squeak —(Like tennis shoes on a clean floor)
Squeak characteristics include the light contact/fast movement/brought on by road conditions/hard surfaces = higher pitch noise/softer surfaces = lower pitch noises/edge to surface = chirping.
- Creak—(Like walking on an old wooden floor)
Creak characteristics include firm contact/slow movement/twisting with a rotational movement/pitch dependent on materials/often brought on by activity.
- Rattle—(Like shaking a baby rattle)
Rattle characteristics include the fast repeated contact/vibration or similar movement/loose parts/missing clip or fastener/incorrect clearance.
- Knock —(Like a knock on a door)
Knock characteristics include hollow sounding/sometimes repeating/often brought on by driver action.
- Tick—(Like a clock second hand)
Tick characteristics include gentle contacting of light materials/loose components/can be caused by driver action or road conditions.
- Thump—(Heavy, muffled knock noise)
Thump characteristics include softer knock/dead sound often brought on by activity.
- Buzz—(Like a bumble bee)
Buzz characteristics include high frequency rattle/firm contact.
- Often the degree of acceptable noise level will vary depending upon the person. A noise that you may judge as acceptable may be very irritating to the customer.
- Weather conditions, especially humidity and temperature, may have a great effect on noise level.

DUPLICATE THE NOISE AND TEST DRIVE

SQUEAK AND RATTLE TROUBLE DIAGNOSES

< SYMPTOM DIAGNOSIS >

If possible, drive the vehicle with the customer until the noise is duplicated. Note any additional information on the Diagnostic Worksheet regarding the conditions or location of the noise. This information can be used to duplicate the same conditions when you confirm the repair.

If the noise can be duplicated easily during the test drive, to help identify the source of the noise, try to duplicate the noise with the vehicle stopped by doing one or all of the following:

- 1) Close a door.
 - 2) Tap or push/pull around the area where the noise appears to be coming from.
 - 3) Rev the engine.
 - 4) Use a floor jack to recreate vehicle "twist".
 - 5) At idle, apply engine load (electrical load, half-clutch on M/T model, drive position on CVT and A/T models).
 - 6) Raise the vehicle on a hoist and hit a tire with a rubber hammer.
- Drive the vehicle and attempt to duplicate the conditions the customer states exist when the noise occurs.
 - If it is difficult to duplicate the noise, drive the vehicle slowly on an undulating or rough road to stress the vehicle body.

CHECK RELATED SERVICE BULLETINS

After verifying the customer concern or symptom, check ASIST for Technical Service Bulletins (TSBs) related to that concern or symptom.

If a TSB relates to the symptom, follow the procedure to repair the noise.

LOCATE THE NOISE AND IDENTIFY THE ROOT CAUSE

1. Narrow down the noise to a general area. To help pinpoint the source of the noise, use a listening tool (Chassis Ear: J-39570, Engine Ear: J-39565 and mechanic's stethoscope).
2. Narrow down the noise to a more specific area and identify the cause of the noise by:
 - removing the components in the area that you suspect the noise is coming from.
Do not use too much force when removing clips and fasteners, otherwise clips and fasteners can be broken or lost during the repair, resulting in the creation of new noise.
 - tapping or pushing/pulling the component that you suspect is causing the noise.
Do not tap or push/pull the component with excessive force, otherwise the noise will be eliminated only temporarily.
 - feeling for a vibration with your hand by touching the component(s) that you suspect is (are) causing the noise.
 - placing a piece of paper between components that you suspect are causing the noise.
 - looking for loose components and contact marks.
Refer to [INT-11, "Generic Squeak and Rattle Troubleshooting"](#).

REPAIR THE CAUSE

- If the cause is a loose component, tighten the component securely.
- If the cause is insufficient clearance between components:
 - separate components by repositioning or loosening and retightening the component, if possible.
 - insulate components with a suitable insulator such as urethane pads, foam blocks, felt cloth tape or urethane tape. A NISSAN Squeak and Rattle Kit (J-43980) is available through your authorized NISSAN Parts Department.

CAUTION:

Do not use excessive force as many components are constructed of plastic and may be damaged.

Always check with the Parts Department for the latest parts information.

The following materials are contained in the NISSAN Squeak and Rattle Kit (J-43980). Each item can be ordered separately as needed.

URETHANE PADS [1.5 mm (0.059 in) thick]

Insulates connectors, harness, etc.

76268-9E005: 100×135 mm (3.94×5.31 in)/76884-71L01: 60×85 mm (2.36×3.35 in)/76884-71L02: 15×25 mm (0.59×0.98 in)

INSULATOR (Foam blocks)

Insulates components from contact. Can be used to fill space behind a panel.

73982-9E000: 45 mm (1.77 in) thick, 50×50 mm (1.97×1.97 in)/73982-50Y00: 10 mm (0.39 in) thick, 50×50 mm (1.97×1.97 in)

INSULATOR (Light foam block)

80845-71L00: 30 mm (1.18 in) thick, 30×50 mm (1.18×1.97 in)

FELT CLOTH TAPE

Used to insulate where movement does not occur. Ideal for instrument panel applications.

68370-4B000: 15×25 mm (0.59×0.98 in) pad/68239-13E00: 5 mm (0.20 in) wide tape roll. The following materials not found in the kit can also be used to repair squeaks and rattles.

SQUEAK AND RATTLE TROUBLE DIAGNOSES

< SYMPTOM DIAGNOSIS >

UHMW (TEFLON) TAPE

Insulates where slight movement is present. Ideal for instrument panel applications.

SILICONE GREASE

Used instead of UHMW tape that will be visible or not fit.

Note: Will only last a few months.

SILICONE SPRAY

Use when grease cannot be applied.

DUCT TAPE

Use to eliminate movement.

CONFIRM THE REPAIR

Confirm that the cause of a noise is repaired by test driving the vehicle. Operate the vehicle under the same conditions as when the noise originally occurred. Refer to the notes on the Diagnostic Worksheet.

Generic Squeak and Rattle Troubleshooting

INFOID:000000009020420

Refer to Table of Contents for specific component removal and installation information.

INSTRUMENT PANEL

Most incidents are caused by contact and movement between:

1. Cluster lid A and the instrument panel
2. Acrylic lens and combination meter housing
3. Instrument panel to front pillar finisher
4. Instrument panel to windshield
5. Instrument panel pins
6. Wiring harnesses behind the combination meter
7. A/C defroster duct and duct joint

These incidents can usually be located by tapping or moving the components to duplicate the noise or by pressing on the components while driving to stop the noise. Most of these incidents can be repaired by applying felt cloth tape or silicone spray (in hard to reach areas). Urethane pads can be used to insulate wiring harness.

CAUTION:

Do not use silicone spray to isolate a squeak or rattle. If you saturate the area with silicone, you will not be able to recheck the repair.

CENTER CONSOLE

Components to pay attention to include:

1. Shift selector assembly cover to finisher
2. A/C control unit and cluster lid C
3. Wiring harnesses behind audio and A/C control unit

The instrument panel repair and isolation procedures also apply to the center console.

DOORS

Pay attention to the:

1. Finisher and inner panel making a slapping noise
2. Inside handle escutcheon to door finisher
3. Wiring harnesses tapping
4. Door striker out of alignment causing a popping noise on starts and stops

Tapping or moving the components or pressing on them while driving to duplicate the conditions can isolate many of these incidents. You can usually insulate the areas with felt cloth tape or insulator foam blocks from the NISSAN Squeak and Rattle Kit (J-43980) to repair the noise.

TRUNK

Trunk noises are often caused by a loose jack or loose items put into the trunk by the owner.

In addition look for:

1. Trunk lid bumpers out of adjustment
2. Trunk lid striker out of adjustment
3. The trunk lid torsion bars knocking together

A

B

C

D

E

F

G

H

I

INT

K

L

M

N

O

P

SQUEAK AND RATTLE TROUBLE DIAGNOSES

< SYMPTOM DIAGNOSIS >

4. A loose license plate or bracket

Most of these incidents can be repaired by adjusting, securing or insulating the item(s) or component(s) causing the noise.

SUNROOF/HEADLINING

Noises in the sunroof/headlining area can often be traced to one of the following:

1. Sunroof lid, rail, linkage or seals making a rattle or light knocking noise
2. Sun visor shaft shaking in the holder
3. Front or rear windshield touching headlining and squeaking

Again, pressing on the components to stop the noise while duplicating the conditions can isolate most of these incidents. Repairs usually consist of insulating with felt cloth tape.

OVERHEAD CONSOLE (FRONT AND REAR)

Overhead console noises are often caused by the console panel clips not being engaged correctly. Most of these incidents are repaired by pushing up on the console at the clip locations until the clips engage.

In addition look for:

1. Loose harness or harness connectors.
2. Front console map/reading lamp lens loose.
3. Loose screws at console attachment points.

SEATS

When isolating seat noise it's important to note the position the seat is in and the load placed on the seat when the noise is present. These conditions should be duplicated when verifying and isolating the cause of the noise.

Cause of seat noise include:

1. Headrest rods and holder
2. A squeak between the seat pad cushion and frame
3. The rear seatback lock and bracket

These noises can be isolated by moving or pressing on the suspected components while duplicating the conditions under which the noise occurs. Most of these incidents can be repaired by repositioning the component or applying urethane tape to the contact area.

UNDERHOOD

Some interior noise may be caused by components under the hood or on the engine wall. The noise is then transmitted into the passenger compartment.

Causes of transmitted underhood noise include:

1. Any component installed to the engine wall
2. Components that pass through the engine wall
3. Engine wall mounts and connectors
4. Loose radiator installation pins
5. Hood bumpers out of adjustment
6. Hood striker out of adjustment

These noises can be difficult to isolate since they cannot be reached from the interior of the vehicle. The best method is to secure, move or insulate one component at a time and test drive the vehicle. Also, engine rpm or load can be changed to isolate the noise. Repairs can usually be made by moving, adjusting, securing, or insulating the component causing the noise.

SQUEAK AND RATTLE TROUBLE DIAGNOSES

< SYMPTOM DIAGNOSIS >

Diagnostic Worksheet

INFOID:000000009020421

Dear Customer:

We are concerned about your satisfaction with your vehicle. Repairing a squeak or rattle sometimes can be very difficult. To help us fix your vehicle right the first time, please take a moment to note the area of the vehicle where the squeak or rattle occurs and under what conditions. You may be asked to take a test drive with a service advisor or technician to ensure we confirm the noise you are hearing.

SQUEAK & RATTLE DIAGNOSTIC WORKSHEET

I. WHERE DOES THE NOISE COME FROM? (circle the area of the vehicle)

The illustrations are for reference only, and may not reflect the actual configuration of your vehicle.

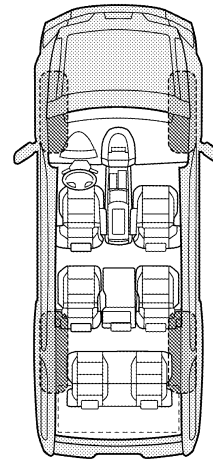
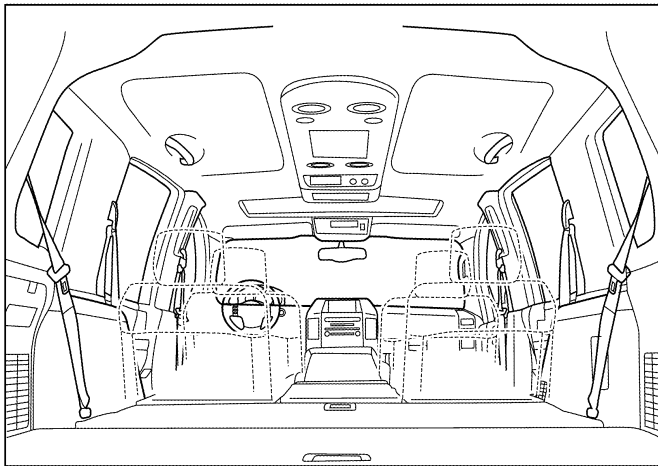
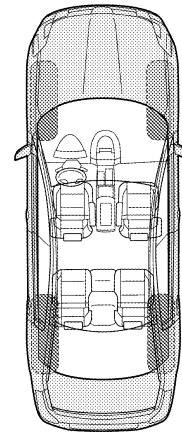
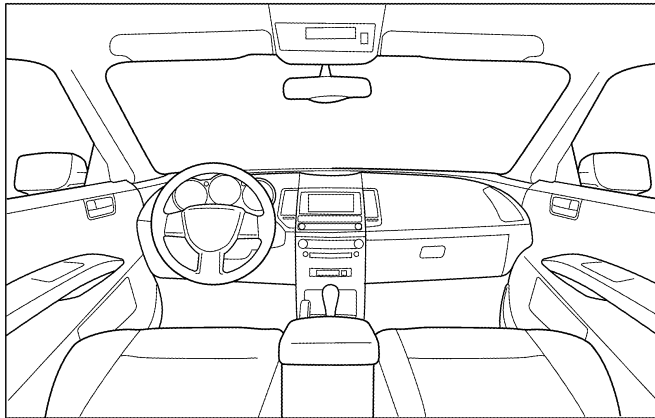

Continue to page 2 of the worksheet and briefly describe the location of the noise or rattle. In addition, please indicate the conditions which are present when the noise occurs.

A
B
C
D
E
F
G
H
I
INT
K
L
M
N
O
P

SQUEAK AND RATTLE TROUBLE DIAGNOSES

< SYMPTOM DIAGNOSIS >

SQUEAK & RATTLE DIAGNOSTIC WORKSHEET - page 2

Briefly describe the location where the noise occurs:

II. WHEN DOES IT OCCUR? (please check the boxes that apply)

- | | |
|---|--|
| <input type="checkbox"/> Anytime | <input type="checkbox"/> After sitting out in the rain |
| <input type="checkbox"/> 1st time in the morning | <input type="checkbox"/> When it is raining or wet |
| <input type="checkbox"/> Only when it is cold outside | <input type="checkbox"/> Dry or dusty conditions |
| <input type="checkbox"/> Only when it is hot outside | <input type="checkbox"/> Other: |

III. WHEN DRIVING:

- Through driveways
- Over rough roads
- Over speed bumps
- Only about ____ mph
- On acceleration
- Coming to a stop
- On turns: left, right or either (circle)
- With passengers or cargo
- Other: _____
- After driving ____ miles or ____ minutes

IV. WHAT TYPE OF NOISE

- Squeak (like tennis shoes on a clean floor)
- Creak (like walking on an old wooden floor)
- Rattle (like shaking a baby rattle)
- Knock (like a knock at the door)
- Tick (like a clock second hand)
- Thump (heavy muffled knock noise)
- Buzz (like a bumble bee)

TO BE COMPLETED BY DEALERSHIP PERSONNEL

Test Drive Notes:

	YES	NO	Initials of person performing
Vehicle test driven with customer	<input type="checkbox"/>	<input type="checkbox"/>	_____
- Noise verified on test drive	<input type="checkbox"/>	<input type="checkbox"/>	_____
- Noise source located and repaired	<input type="checkbox"/>	<input type="checkbox"/>	_____
- Follow up test drive performed to confirm repair	<input type="checkbox"/>	<input type="checkbox"/>	_____

VIN: _____ Customer Name _____
W.O.# _____ Date: _____

This form must be attached to Work Order

LATA0071E

FRONT DOOR FINISHER

< REMOVAL AND INSTALLATION >

REMOVAL AND INSTALLATION

FRONT DOOR FINISHER

Exploded View

INFOID:000000008507099

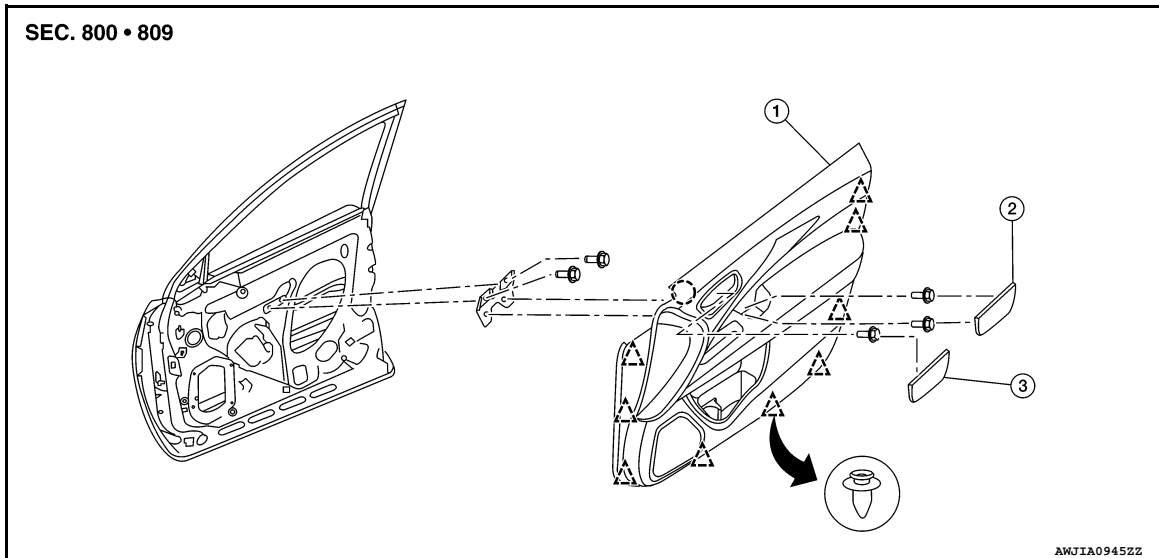

1. Front door finisher

2. Armrest cover

3. Inside door handle escutcheon

△ Clip

○ Pawl

Removal and Installation

INFOID:000000008507100

REMOVAL

1. Remove the armrest cover using a suitable tool.
2. Remove the front door finisher bolts.
3. Remove the inside door handle escutcheon using a suitable tool, then remove the inside door handle escutcheon bolt.
4. Remove the step lamp. Refer to [INL-62. "Removal and Installation"](#).
5. Remove the main power window and door lock/unlock switch or power windows and door lock/unlock switch RH. Refer to [PWC-62. "Removal and Installation"](#) [MAIN POWER WINDOW AND DOOR LOCK/UNLOCK SWITCH - LH FRONT ONLY AUTO DOWN], [PWC-63. "Removal and Installation"](#) [POWER WINDOW AND DOOR LOCK/UNLOCK SWITCH RH - LH FRONT ONLY AUTO DOWN], [PWC-137. "Removal and Installation"](#) [MAIN POWER WINDOW AND DOOR LOCK/UNLOCK SWITCH - LH & RH FRONT AUTO UP/DOWN] or [PWC-138. "Removal and Installation"](#) [POWER WINDOW AND DOOR LOCK/UNLOCK SWITCH RH - LH & RH FRONT AUTO UP/DOWN].
6. Release the front door finisher clips and pawls using a suitable tool.
7. Disconnect the harness connector from the front door finisher.
8. Disconnect the door lock cable and inside door handle cable from front door finisher.
9. Remove the front door finisher.

INSTALLATION

Installation is in the reverse order of removal.

CAUTION:

- Visually check the clips and pawls for deformation and damage during installation. Replace with new ones if necessary.
- When installing front door finisher, check that clips and pawls are securely placed in body panel holes.

A
B
C
D
E
F
G
H
I
INT
K
L
M
N
O
P

REAR DOOR FINISHER

< REMOVAL AND INSTALLATION >

REAR DOOR FINISHER

Exploded View

INFOID:000000008507101

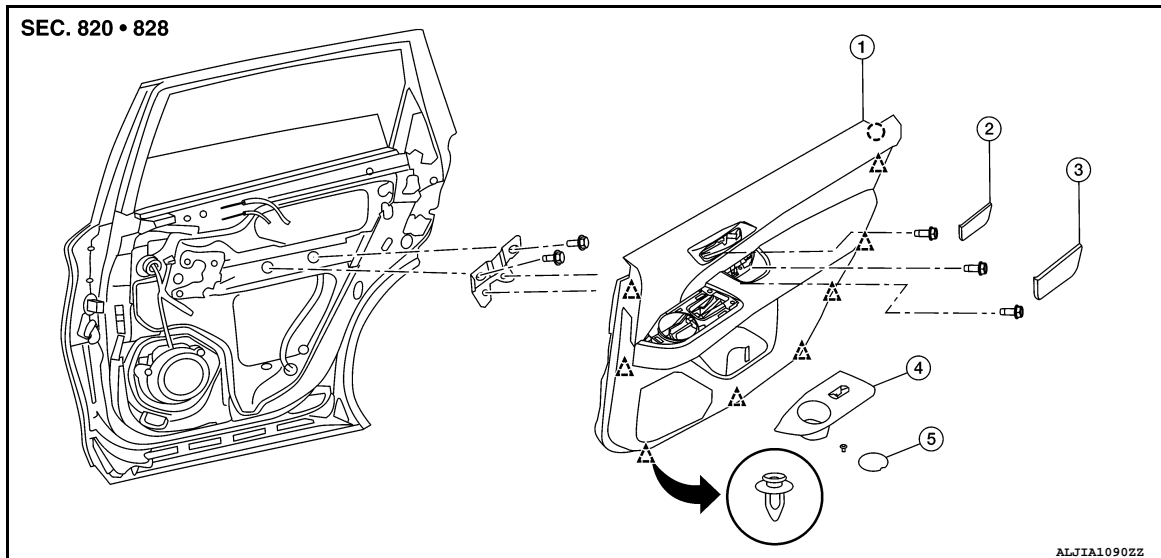

1. Rear door finisher

2. Armrest cover

3. Inside door handle escutcheon

4. Cup holder

5. Cup holder cover

△ Clip

○ Pawl

Removal and Installation

INFOID:000000008507102

REMOVAL

1. Remove the armrest cover using a suitable tool.
2. Remove the rear door finisher bolts.
3. Remove the inside door handle escutcheon using a suitable tool, then remove the inside door handle escutcheon bolt.
4. Remove the rear power window switch. Refer to [PWC-64, "Removal and Installation"](#) [LH FRONT ONLY AUTO DOWN] or [PWC-139, "Removal and Installation"](#) [LH & RH FRONT AUTO UP/DOWN].
5. Release the rear door finisher clips and pawls using a suitable tool.
6. Disconnect the harness connector from the rear door finisher.
7. Disconnect the door lock cable and inside door handle cable from the rear door finisher.
8. Remove the rear door finisher.

INSTALLATION

Installation is in the reverse order of removal.

CAUTION:

- Visually check the clips and pawls for deformation and damage during installation. Replace with new ones if necessary.
- When installing rear door finisher, check that clips and pawls are securely placed in body panel holes.

BODY SIDE TRIM

< REMOVAL AND INSTALLATION >

BODY SIDE TRIM

Exploded View

INFOID:000000008507103

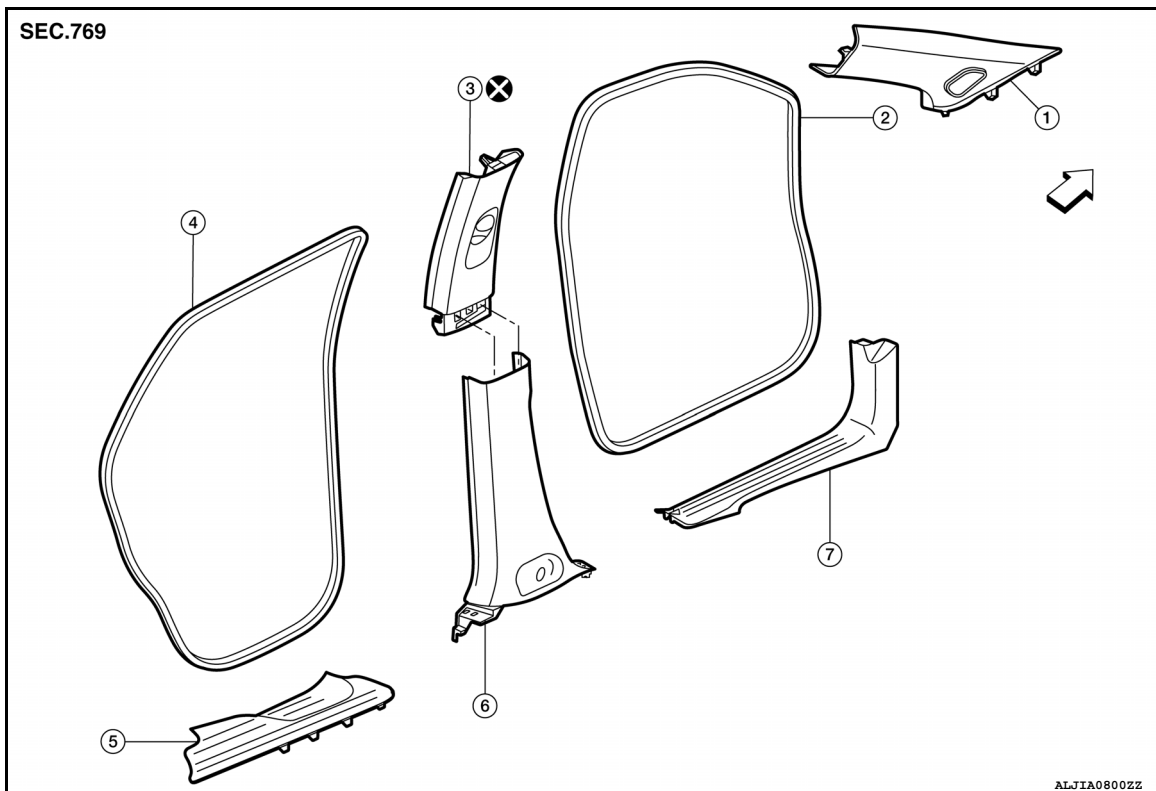

- | | | |
|--------------------------|-----------------------|---------------------------------|
| 1. Front pillar finisher | 2. Front door welt | 3. Center pillar upper finisher |
| 4. Rear door welt | 5. Rear kicking plate | 6. Center pillar lower finisher |
| 7. Front kicking plate | ← Front | |

FRONT PILLAR FINISHER

FRONT PILLAR FINISHER : Removal and Installation

INFOID:000000008507104

REMOVAL

1. Partially remove the front door welt. Refer to [INT-19. "BODY SIDE WELT : Removal and Installation - Front Door Welt"](#).

BODY SIDE TRIM

< REMOVAL AND INSTALLATION >

2. Release the front pillar finisher metal clip and pawls using a suitable tool.
□: Metal clip
△: Clip
○: Pawl
3. Release the tether clip (A) from the front pillar finisher.
CAUTION:
Do not reuse the tether clip (A).

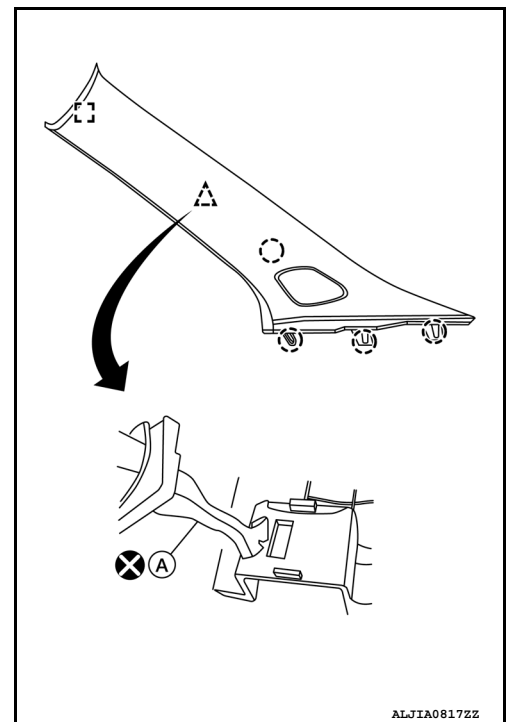

4. Disconnect the harness connector from the front pillar finisher, then remove the front pillar finisher (LH/RH).

INSTALLATION

Installation is in the reverse order of removal.

CAUTION:

- Visually check the metal clip and pawls for deformation and damage during installation. Replace with new ones if necessary.
- Do not reuse the tether clip. Replace with new part after removal.
- When installing front pillar finisher, check that the metal clip, tether clip, and pawls are securely placed in body panel holes.

CENTER PILLAR UPPER FINISHER

CENTER PILLAR UPPER FINISHER : Removal and Installation

INFOID:000000008507105

REMOVAL

1. Move the front seat to the full forward position.
2. Remove the center pillar lower finisher. Refer to [INT-19. "CENTER PILLAR LOWER FINISHER : Removal and Installation"](#).
3. Release the center pillar upper finisher pawl and clips using a suitable tool.

CAUTION:

Do not bend the sheet metal when removing the center pillar upper finisher from the sheet metal.

- △: Clip
○: Pawl

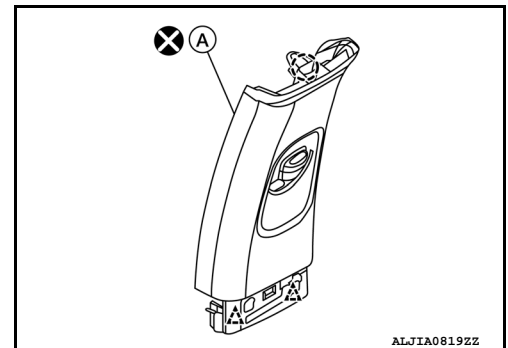

4. Remove the seat belt from the center pillar upper finisher, then remove the center pillar upper finisher (LH/RH).
CAUTION:
Do not reuse center pillar upper finisher (A).

BODY SIDE TRIM

< REMOVAL AND INSTALLATION >

INSTALLATION

Installation is in the reverse order of removal.

CAUTION:

- Do not reuse center pillar upper finisher. Replace with new part for installation.
- Visually check the clips for deformation and damage during installation. Replace with new ones if necessary.
- When installing center pillar upper finisher, check that the clips and pawl are securely placed in body panel holes.

CENTER PILLAR LOWER FINISHER

CENTER PILLAR LOWER FINISHER : Removal and Installation

INFOID:000000008507106

REMOVAL

1. Move the front seat to the full forward position.
2. Remove the front kicking plate. Refer to [INT-20, "KICKING PLATE : Removal and Installation - Front Kicking Plate"](#).
3. Remove the rear kicking plate. Refer to [INT-20, "KICKING PLATE : Removal and Installation - Rear Kicking Plate"](#).
4. Remove the seat belt bolt from the center pillar lower finisher.
5. Release the center pillar lower finisher clips using a suitable tool, then remove the center pillar lower finisher.

△: Clip

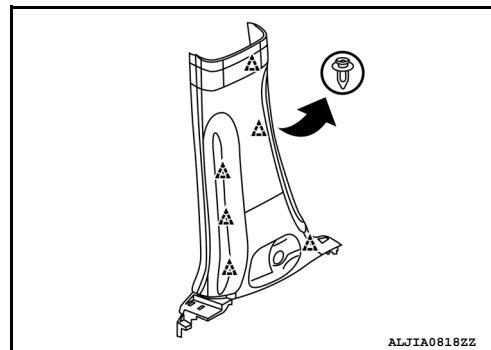

INSTALLATION

Installation is in the reverse order of removal.

CAUTION:

- Visually check the clips for deformation and damage during installation. Replace with new ones if necessary.
- When installing center pillar lower finisher, check that clips are securely placed in body panel holes.

BODY SIDE WELT

BODY SIDE WELT : Removal and Installation - Front Door Welt

INFOID:000000008507107

REMOVAL

1. Remove the center pillar upper finisher. Refer to [INT-18, "CENTER PILLAR UPPER FINISHER : Removal and Installation"](#).
2. Remove the front body side welt.

INSTALLATION

Installation is in the reverse order of removal.

BODY SIDE WELT : Removal and Installation - Rear Door Welt

INFOID:000000008507108

REMOVAL

1. Remove the center pillar upper finisher. Refer to [INT-18, "CENTER PILLAR UPPER FINISHER : Removal and Installation"](#).
2. Remove the rear body side welt.

INSTALLATION

BODY SIDE TRIM

< REMOVAL AND INSTALLATION >

Installation is in the reverse order of removal.

KICKING PLATE

KICKING PLATE : Removal and Installation - Front Kicking Plate

INFOID:000000008507109

REMOVAL

1. Release the front kicking plate metal clips and pawls using a suitable tool.

- : Metal clip
- : Pawl
- ←: Front

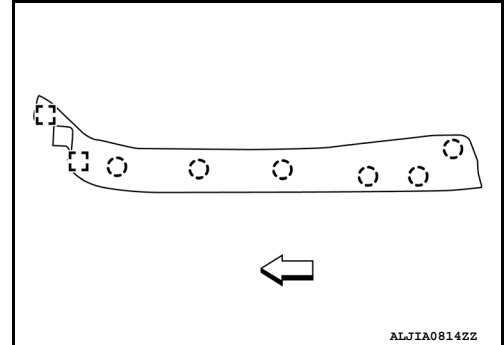

2. Remove the front kicking plate.

INSTALLATION

Installation is in the reverse order of removal.

CAUTION:

- Visually check the clips and pawls for deformation and damage during installation. Replace with new ones if necessary.
- When installing front kicking plate, check that the clips and pawls are securely placed in body panel holes.

KICKING PLATE : Removal and Installation - Rear Kicking Plate

INFOID:000000008507110

REMOVAL

1. Release the rear kicking plate clips and pawls using a suitable tool.

- △: Clip
- : Pawl
- ←: Front

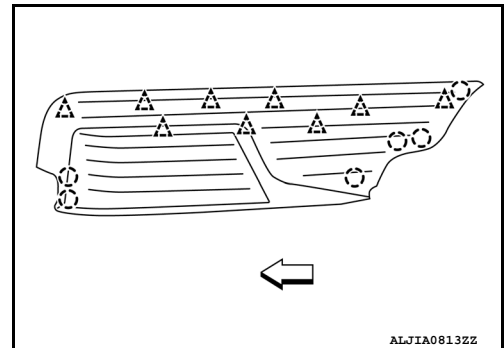

2. Remove the rear kicking plate.

INSTALLATION

Installation is in the reverse order of removal.

CAUTION:

- Visually check the clips and pawls for deformation and damage during installation. Replace with new ones if necessary.
- When installing rear kicking plate, check that the clips and pawls are securely placed in body panel holes.

FLOOR TRIM

< REMOVAL AND INSTALLATION >

FLOOR TRIM

Exploded View

INFOID:000000008507111

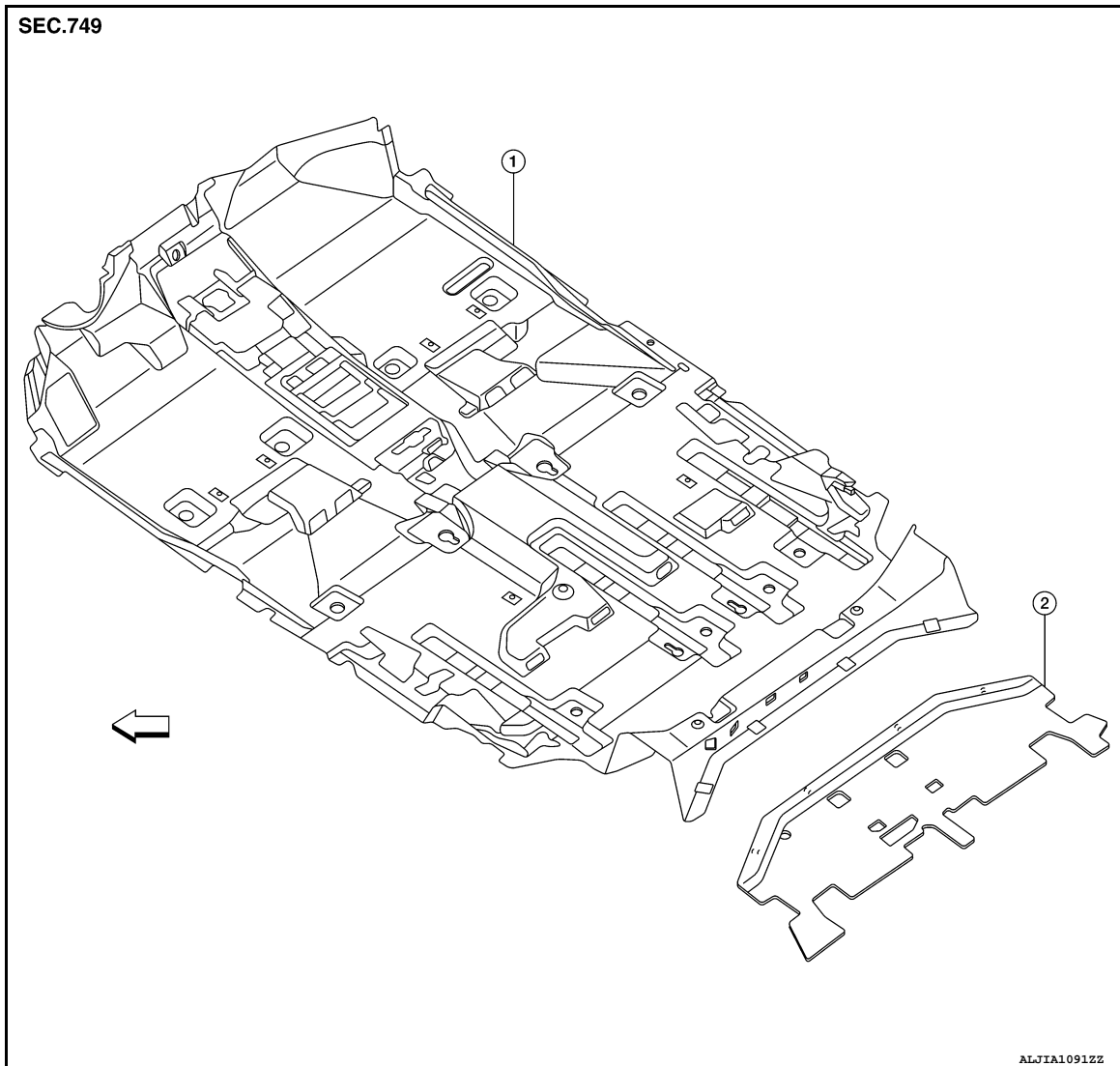

1. Front floor trim

2. Rear floor trim

← Front

Removal and Installation

INFOID:000000008507112

FRONT FLOOR TRIM

Removal

CAUTION:

Before servicing, turn the ignition switch off, disconnect both battery cables and wait at least three minutes.

1. Disconnect the negative battery terminal, then wait at least three minutes.
2. Remove the front kicking plates (LH/RH). Refer to [INT-20, "KICKING PLATE : Removal and Installation - Front Kicking Plate"](#).
3. Remove the rear kicking plates (LH/RH). Refer to [INT-20, "KICKING PLATE : Removal and Installation - Rear Kicking Plate"](#).
4. Remove the front seat assemblies (LH/RH). Refer to [SE-85, "Removal and Installation"](#).
5. Remove the center blower unit. Refer to [VTL-19, "CENTER BLOWER UNIT : Removal and Installation"](#).

A
B
C
D
E
F
G
H
I

INT

K
L

M

N

O

P

FLOOR TRIM

< REMOVAL AND INSTALLATION >

6. Remove the second row seats. Refer to [SE-91. "Removal and Installation"](#).
7. Remove the front floor trim.

Installation

Installation is in the reverse order of removal.

REAR FLOOR TRIM

Removal

1. Remove the back door kicking plate. Refer to [INT-33. "BACK DOOR KICKING PLATE : Removal and Installation"](#)
2. Remove the third row seat. Refer to [SE-100. "Removal and Installation"](#).
3. Remove the storage box side finishers (LH/RH). Refer to [INT-30. "STORAGE BOX SIDE FINISHER : Removal and Installation"](#).
4. Remove the luggage side lower finishers (LH/RH). Refer to [INT-28. "LUGGAGE SIDE LOWER FINISHER : Removal and Installation"](#).
5. Remove the rear floor trim.

Installation

Installation is in the reverse order of removal.

HEADLINING

< REMOVAL AND INSTALLATION >

HEADLINING

Exploded View

INFOID:000000008507113

With rear sunroof

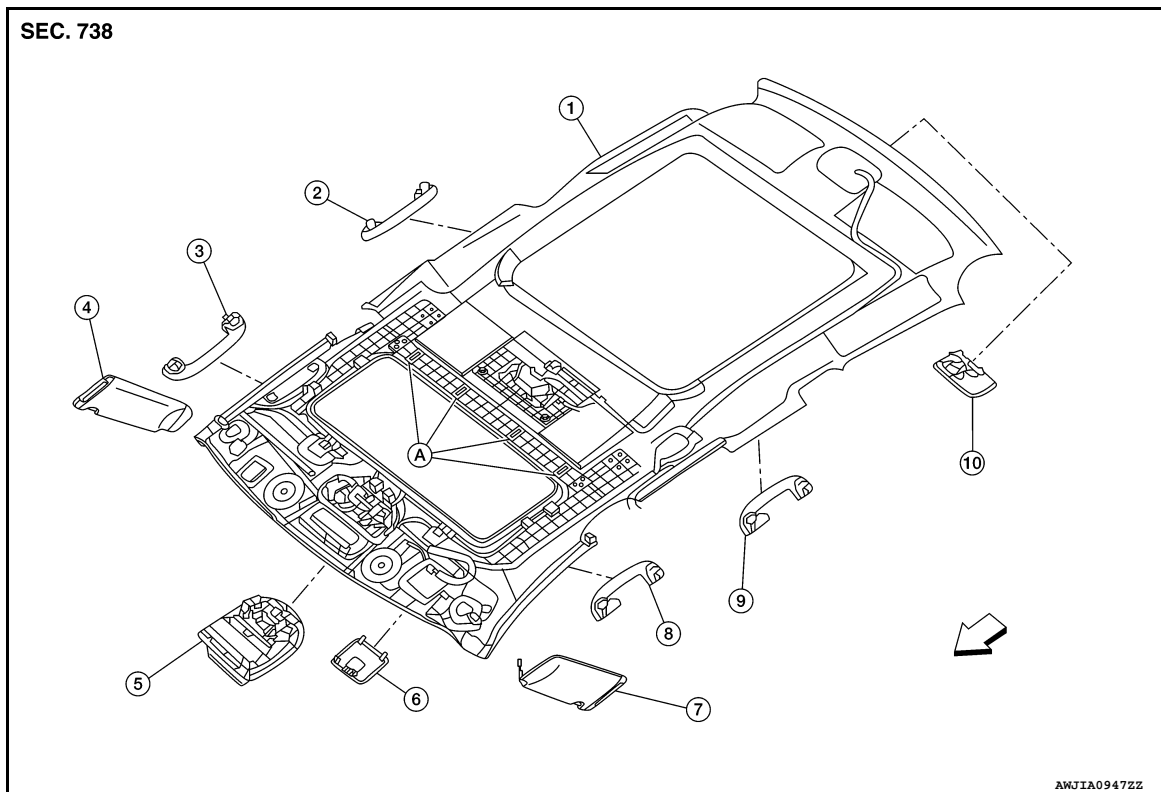

- | | | |
|-------------------|---------------------------------|----------------------------|
| 1. Headlining | 2. Rear assist grip (RH) | 3. Front assist grip (RH) |
| 4. Sun visor (RH) | 5. Front room/map lamp assembly | 6. Headlining access cover |
| 7. Sun visor (LH) | 8. Front assist grip (LH) | 9. Rear assist grip (LH) |
| 10. Cargo lamp | A. Magnetic clip | ⇐ Front |

A
B
C
D
E
F
G
H
I

INT

K
L
M
N
O
P

HEADLINING

< REMOVAL AND INSTALLATION >

Without rear sunroof

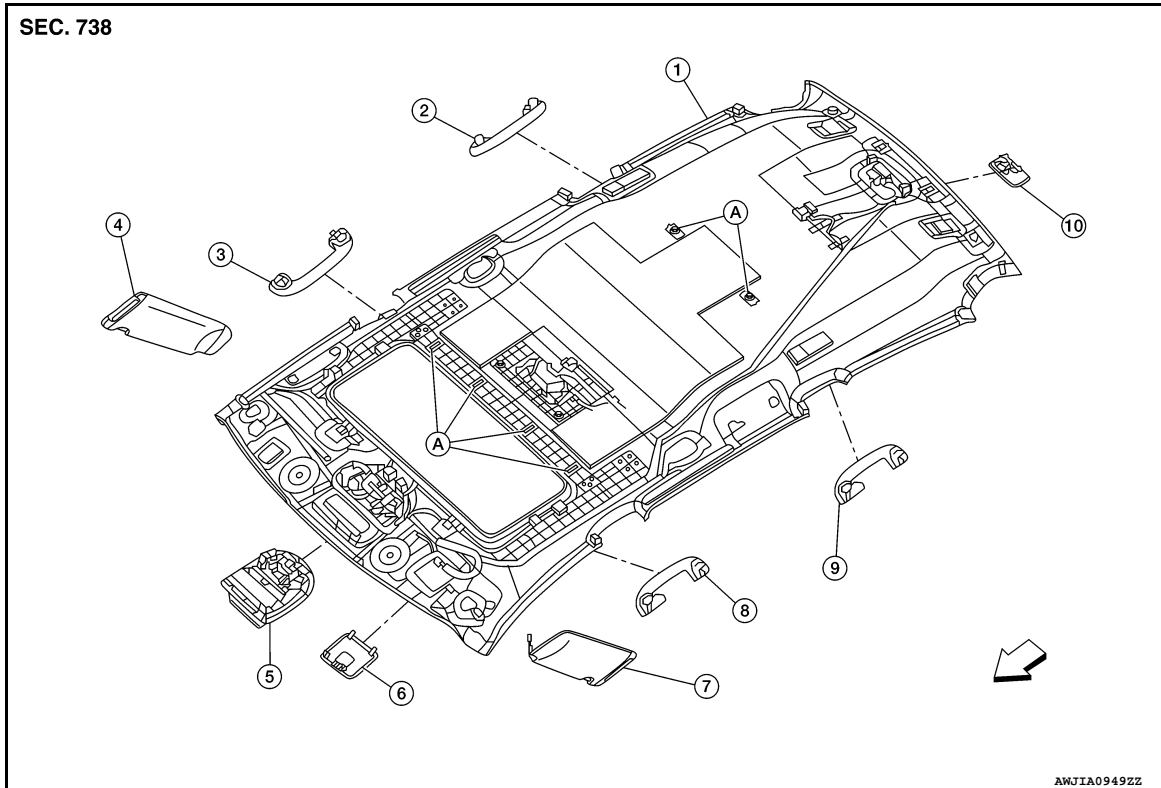

- | | | |
|-------------------|---------------------------------|----------------------------|
| 1. Headlining | 2. Rear assist grip (RH) | 3. Front assist grip (RH) |
| 4. Sun visor (RH) | 5. Front room/map lamp assembly | 6. Headlining access cover |
| 7. Sun visor (LH) | 8. Front assist grip (LH) | 9. Rear assist grip (LH) |
| 10. Cargo lamp | ↶ Front | |

Removal and Installation

INFOID:000000008507114

REMOVAL

1. Remove sun visor cap (A) using a suitable tool.

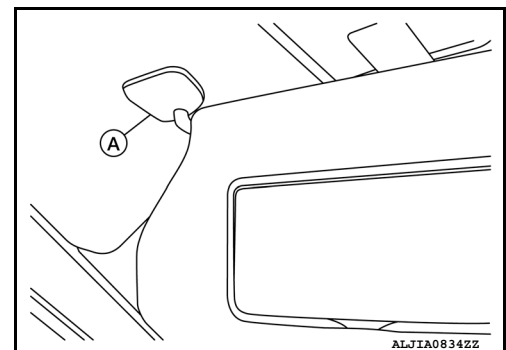

2. Remove sun visor screws.
3. Disconnect the harness connector from the vanity mirror lamp, and remove sun visors (LH/RH).

HEADLINING

< REMOVAL AND INSTALLATION >

4. Insert a suitable tool (A) at approximately a 30 degree angle into the sun visor holder notch on the front of the sun visor holder (1). Press in to release the locking tab (B). While holding in locking tab (B), turn the sun visor holder (1) 90 degrees to release it from the headliner.

- If the sun visor holder (1) does not fully rotate, make sure that the suitable tool (A) is pressing in on the locking tab (B) and is not positioned under locking tab (B). Reinsert the suitable tool (A) as necessary to release the locking tab (B).

- \leftarrow: Front

CAUTION:

Do not force the sun visor holder when removing as the locking tab may be damaged if the suitable tool is not positioned correctly.

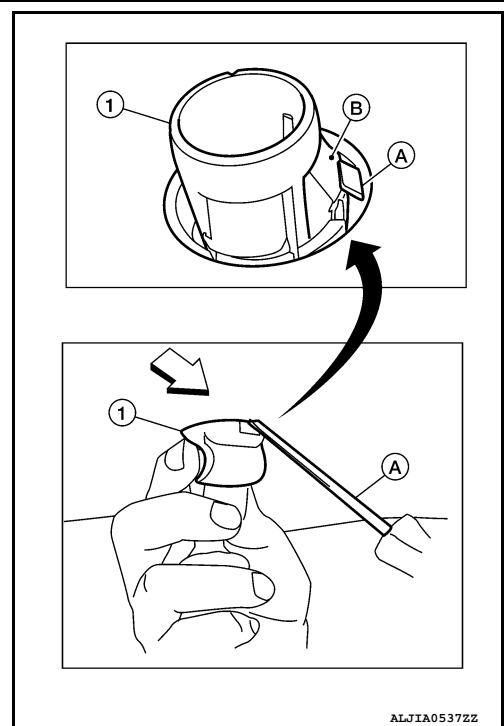

5. Remove the inside mirror finisher(1).
6. Disconnect the harness connector (A) from the inside mirror (2).

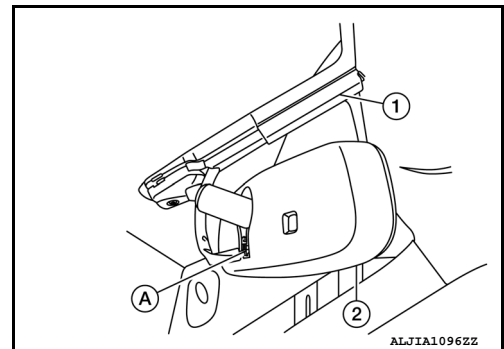

7. Remove all assist grips.
 - a. Release assist grip clip (1) using a suitable tool (A). Slide assist grip clip forward and remove.
△: Clip
 - b. Slide assist grip (2) forward and remove.

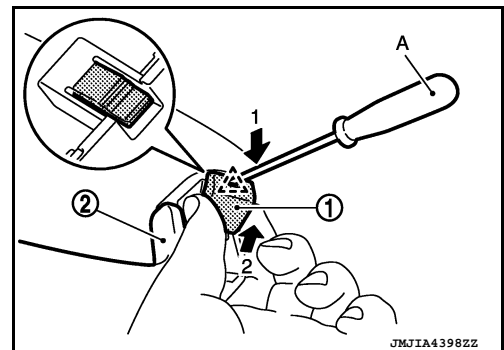

8. Remove front pillar finishers (LH/RH). Refer to [INT-17, "FRONT PILLAR FINISHER : Removal and Installation"](#).
9. Remove front door welts (LH/RH). Refer to [INT-19, "BODY SIDE WELT : Removal and Installation - Front Door Welt"](#).
10. Remove rear door welts (LH/RH). Refer to [INT-19, "BODY SIDE WELT : Removal and Installation - Rear Door Welt"](#).
11. Remove center pillar upper finishers (LH/RH). Refer to [INT-18, "CENTER PILLAR UPPER FINISHER : Removal and Installation"](#).

A
B
C
D
E
F
G
H
I
INT
K
L
M
N
O
P

HEADLINING

< REMOVAL AND INSTALLATION >

12. Remove rear pillar finishers (LH/RH). Refer to [INT-27. "REAR PILLAR FINISHER : Removal and Installation"](#).
13. Remove back pillar finishers (LH/RH). Refer to [INT-29. "BACK PILLAR FINISHER : Removal and Installation"](#).
14. Remove luggage side upper finishers (LH/RH). Refer to [INT-29. "LUGGAGE SIDE UPPER FINISHER : Removal and Installation"](#).
15. Remove the third row seat. Refer to [SE-100. "Removal and Installation"](#).
16. Remove headlining clips located at the rear of the headlining.
17. Remove headlining (1) through the back door.

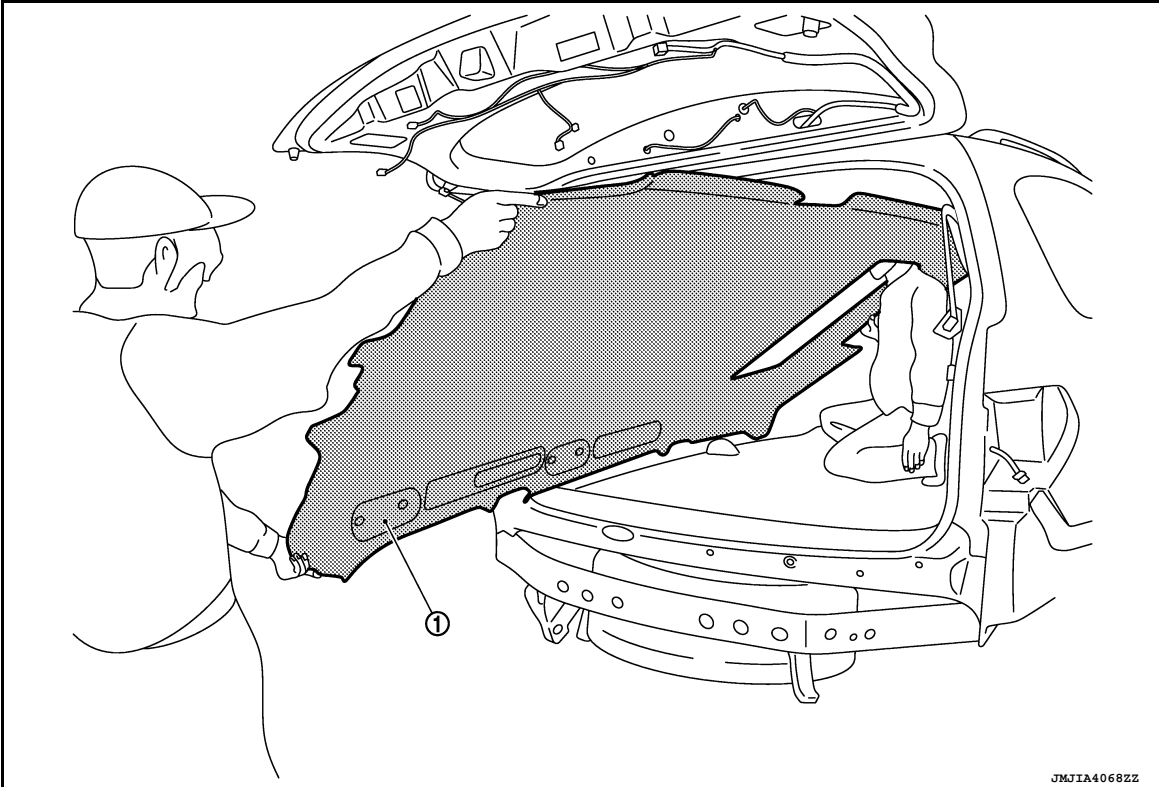

CAUTION:

- When removing headlining, two people are required.
- Do not bend headlining when removing.
- Be careful not to scratch or damage any part of the body while removing the headlining.

INSTALLATION

Installation is in the reverse order of removal.

CAUTION:

Do not to bend headlining when installing.

NOTE:

Install metal clips of map lamp assembly and clips of the rear end of headlining for positioning.

LUGGAGE FLOOR TRIM

< REMOVAL AND INSTALLATION >

LUGGAGE FLOOR TRIM

Exploded View

INFOID:000000008507115

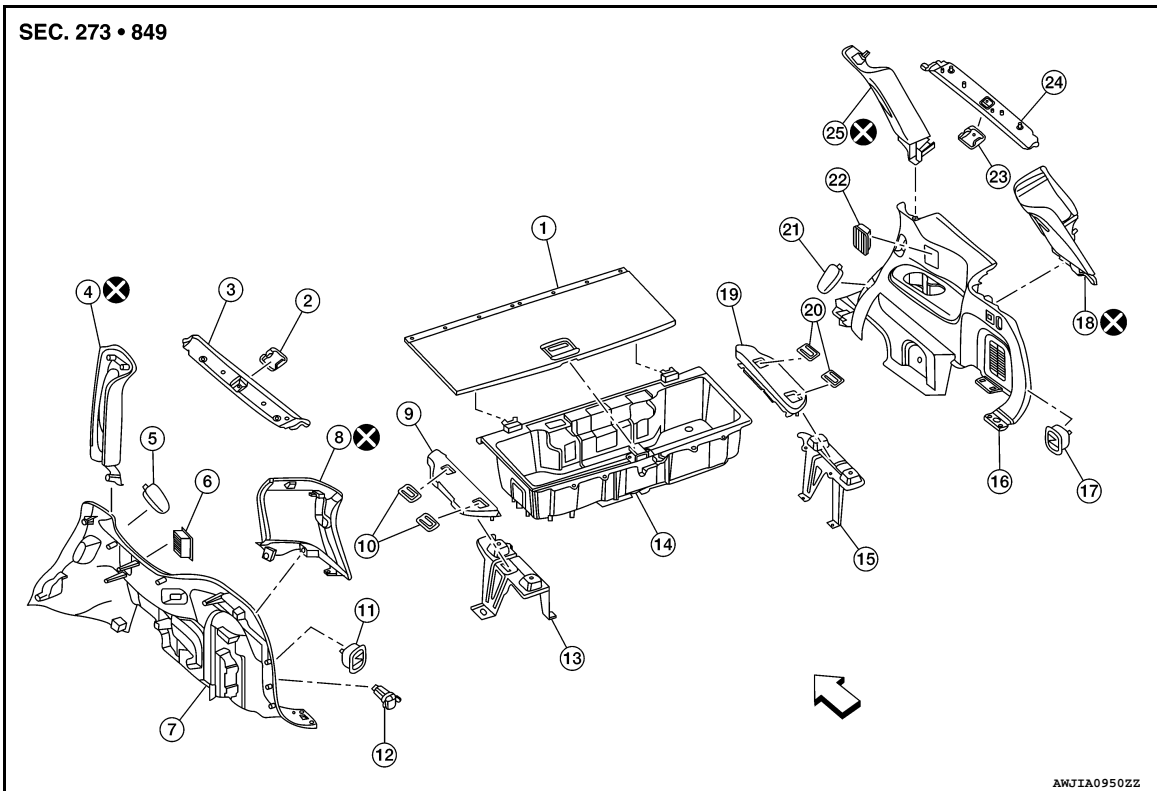

- | | | |
|--|--|--|
| 1. Storage box lid | 2. Luggage side upper finisher cover (LH) | 3. Luggage side upper finisher (LH) |
| 4. Rear pillar finisher (LH) | 5. Luggage side lower finisher cover (LH) | 6. Rear ventilator grille (LH) |
| 7. Luggage side lower finisher (LH) | 8. Back pillar finisher (LH) | 9. Storage box side finisher (LH) |
| 10. Storage box side finisher hook (LH) | 11. Luggage side lower finisher coat hook (LH) | 12. Power socket |
| 13. Storage box side finisher bracket (LH) | 14. Storage box | 15. Storage box side finisher bracket (RH) |
| 16. Luggage side lower finisher (RH) | 17. Luggage side lower finisher coat hook (RH) | 18. Back pillar finisher (RH) |
| 19. Storage box side finishers (RH) | 20. Storage box side finisher hook (RH) | 21. Luggage side lower finisher cover (RH) |
| 22. Rear ventilator grille (RH) | 23. Luggage side upper finisher cover (RH) | 24. Luggage side upper finisher (RH) |
| 25. Rear pillar finisher (RH) | ↔ Front | |

REAR PILLAR FINISHER

REAR PILLAR FINISHER : Removal and Installation

INFOID:000000008507116

REMOVAL

1. Remove the seat belt bolt cover and bolt from the luggage side lower finisher.
2. Remove luggage side lower finisher. Refer to [INT-28, "LUGGAGE SIDE LOWER FINISHER : Removal and Installation"](#)

A
B
C
D
E
F
G
H
I

INT

K

L

M

N

O

P

LUGGAGE FLOOR TRIM

< REMOVAL AND INSTALLATION >

3. Release the rear pillar finisher clips and pawls using a suitable tool.

CAUTION:

Do not bend the sheet metal when removing the rear pillar finisher from the sheet metal.

- △: Clip
○: Pawl

4. Remove the rear pillar finisher (A) from the luggage side lower finisher.
5. Remove the seat belt from the rear pillar finisher (A), then remove the rear pillar finisher.

CAUTION:

Do not reuse rear pillar finisher.

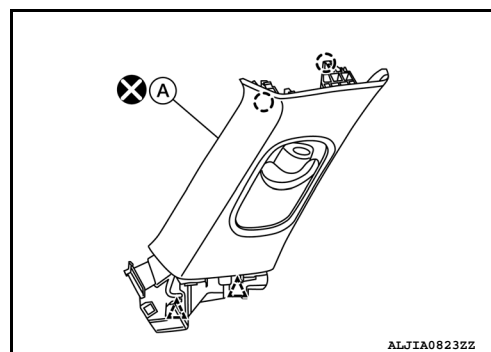

INSTALLATION

Installation is in the reverse order of removal.

CAUTION:

- Do not reuse rear pillar finisher. Replace with new part for installation.
- Visually check the clip and pawls for deformation and damage during installation. Replace with new ones if necessary.
- When installing rear pillar finisher, check that clips and pawls are securely placed in body panel holes.

LUGGAGE SIDE LOWER FINISHER

LUGGAGE SIDE LOWER FINISHER : Removal and Installation

INFOID:000000008507117

REMOVAL

1. Remove the storage box side finisher. Refer to [INT-30. "STORAGE BOX SIDE FINISHER : Removal and Installation"](#).
2. Remove the third row seat. Refer to [SE-100. "Removal and Installation"](#).
3. Partially remove the rear door welt. Refer to [INT-19. "BODY SIDE WELT : Removal and Installation - Rear Door Welt"](#).
4. Remove the seat belt bolt cover and bolt from the luggage side lower finisher.
5. Remove the seat belt from the luggage side lower finisher.
6. Remove the luggage side lower finisher cover, then remove the luggage side lower finisher bolt (A).
⇐: Front

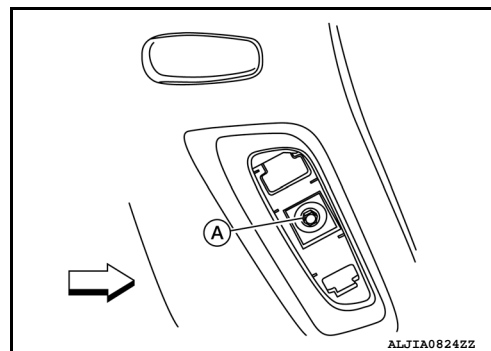

7. Disconnect the harness connector from the power socket (LH only).
8. Remove the luggage side lower finisher.

INSTALLATION

Installation is in the reverse order of removal.

CAUTION:

- Visually check the clips and pawls for deformation and damage during installation. Replace with new ones if necessary.
- When installing luggage side lower finisher, check that clips and pawls are securely placed in body panel holes.

LUGGAGE SIDE UPPER FINISHER

LUGGAGE FLOOR TRIM

< REMOVAL AND INSTALLATION >

LUGGAGE SIDE UPPER FINISHER : Removal and Installation

INFOID:000000008507118

REMOVAL

1. Remove the luggage side upper finisher cover, then remove the luggage side upper finisher bolt (A).

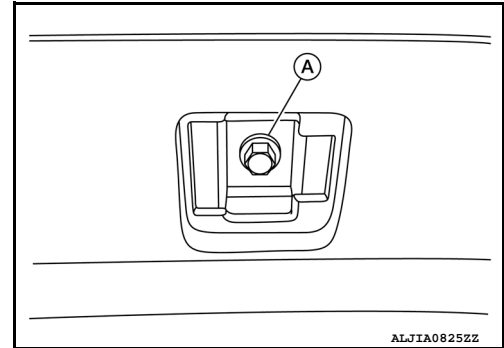

2. Remove rear pillar finisher. Refer to [INT-27, "REAR PILLAR FINISHER : Removal and Installation"](#).
3. Remove back pillar finisher. Refer to [INT-29, "BACK PILLAR FINISHER : Removal and Installation"](#).
4. Release the clips, then remove the luggage side upper finisher.

INSTALLATION

Installation is in the reverse order of removal.

CAUTION:

- Visually check the clips for deformation and damage during installation. Replace with new ones if necessary.
- When installing luggage side upper finisher, check that clips are securely placed in body panel holes.

BACK PILLAR FINISHER

BACK PILLAR FINISHER : Removal and Installation

INFOID:000000008507119

REMOVAL

1. Remove the third row seat. Refer to [SE-100, "Removal and Installation"](#).
2. Remove the seat belt bolt cover and bolt from the luggage side lower finisher.
3. Release the back pillar finisher clips and pawl using a suitable tool, then disconnect the back pillar finisher from the luggage side lower finisher.

CAUTION:

Do not bend the sheet metal when removing the back pillar finisher from the sheet metal.

- △: Clip
- : Pawl

4. Remove the seat belt from the back pillar finisher (A), then remove the back pillar finisher (A).

CAUTION:

Do not reuse back pillar finisher (A).

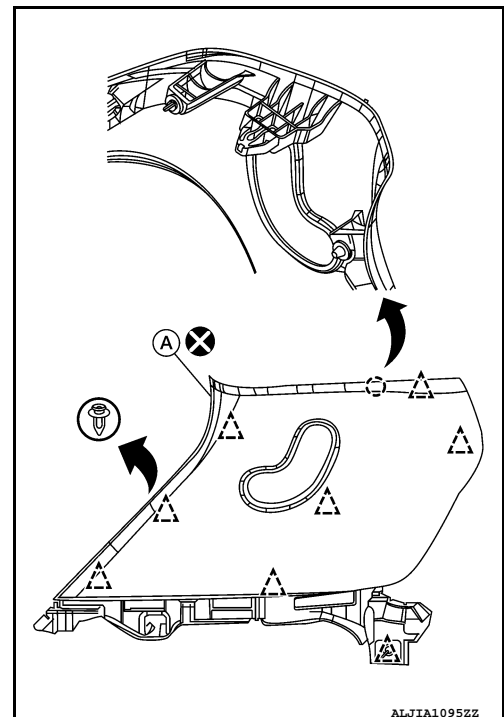

INSTALLATION

A
B
C
D
E
F
G
H
I
K
L
M
N
O
P

INT

LUGGAGE FLOOR TRIM

< REMOVAL AND INSTALLATION >

Installation is in the reverse order of removal.

CAUTION:

- Do not reuse back pillar finisher. Replace with new part for installation.
- Visually check the clips for deformation and damage during installation. Replace with new ones if necessary.
- When installing back pillar garnish, check that the clips and pawl are securely placed in body panel holes.

STORAGE BOX

STORAGE BOX : Removal and Installation

INFOID:000000008507120

REMOVAL

1. Release the clips that retain the seat back board to the storage box lid.
2. Open the storage box lid.
3. Remove the subwoofer from the storage box (if equipped). Refer to [AV-371. "Removal and Installation"](#) [MID AUDIO SYSTEM - WITH BOSE AUDIO SYSTEM] or [AV-599. "Removal and Installation"](#) [PREMIUM AUDIO SYSTEM - WITH NAVIGATION].
4. Remove the storage box screws and the storage box.

INSTALLATION

Installation is in the reverse order of removal.

STORAGE BOX SIDE FINISHER

STORAGE BOX SIDE FINISHER : Removal and Installation

INFOID:000000008507121

REMOVAL

1. Remove the storage box. Refer to [INT-30. "STORAGE BOX : Removal and Installation"](#).
2. Release the clips pawls using a suitable tool, then remove the storage box side finisher.

INSTALLATION

Installation is in the reverse order of removal.

CAUTION:

- Visually check the clips for deformation and damage during installation. Replace with new ones if necessary.
- When installing storage box side finisher, check that the clips and pawls are securely placed in body panel holes.

BACK DOOR TRIM

< REMOVAL AND INSTALLATION >

BACK DOOR TRIM

Exploded View

INFOID:000000008507122

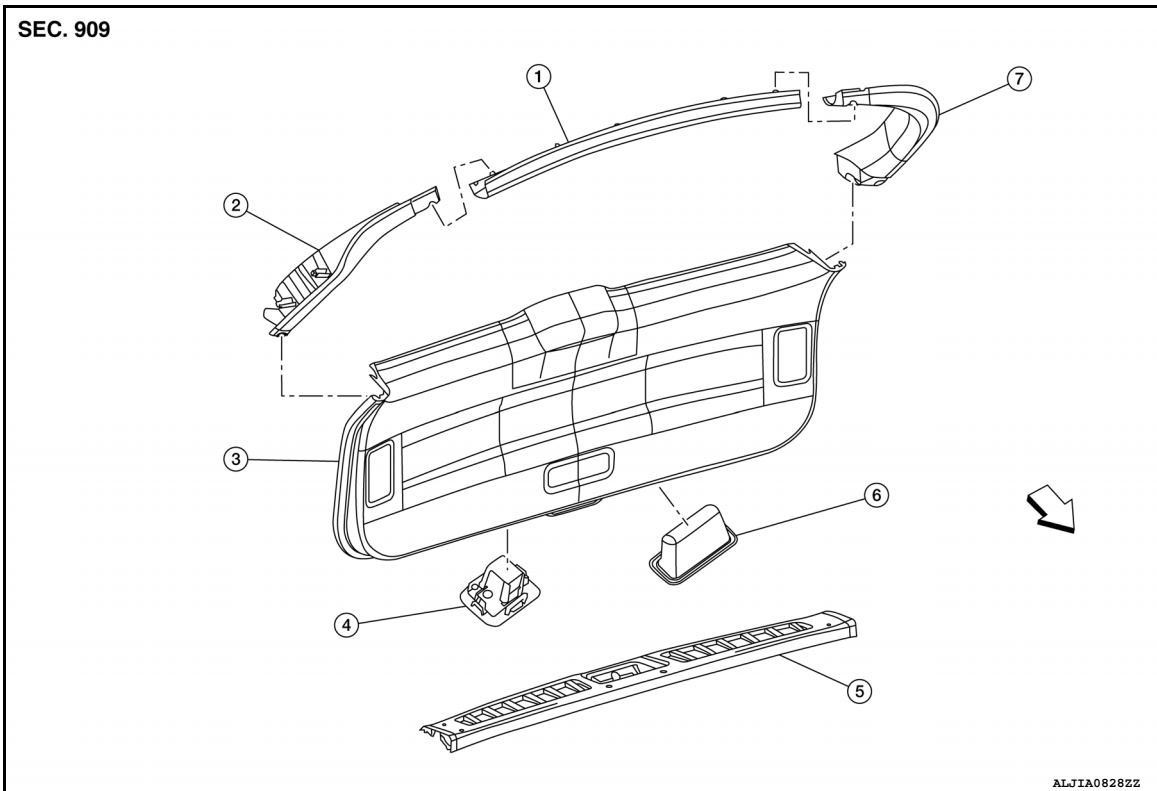

- | | | |
|---------------------------------|---------------------------------|-----------------------------|
| 1. Back door upper finisher | 2. Back door side finisher (RH) | 3. Back door lower finisher |
| 4. Back door switch | 5. Back door kicking plate | 6. Back door pull handle |
| 7. Back door side finisher (LH) | ← Front | |

BACK DOOR UPPER FINISHER

BACK DOOR UPPER FINISHER : Removal and Installation

INFOID:000000008507123

REMOVAL

1. Release the back door upper finisher metal clips using a suitable tool, then remove the back door upper finisher.

 Metal clip

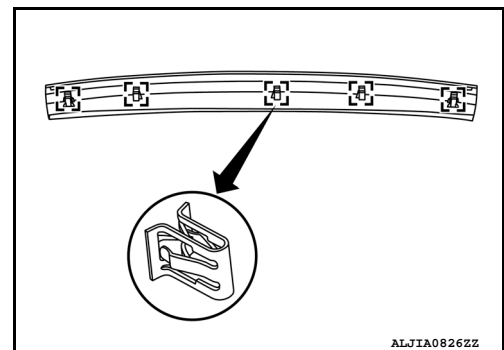

INSTALLATION

Installation is in the reverse order of removal.

CAUTION:

- Visually check the metal clips for deformation and damage during installation. Replace with new ones if necessary.

A
B
C
D
E
F
G
H
I
INT
K
L
M
N
O
P

BACK DOOR TRIM

< REMOVAL AND INSTALLATION >

- When installing back door upper finisher, check that the metal clips are securely placed in body panel holes.

BACK DOOR SIDE FINISHER

BACK DOOR SIDE FINISHER : Removal and Installation

INFOID:000000008507124

REMOVAL

1. Remove the back door upper finisher. Refer to [INT-31, "BACK DOOR UPPER FINISHER : Removal and Installation"](#).
2. Remove the back door lower finisher. Refer to [INT-32, "BACK DOOR LOWER FINISHER : Removal and Installation"](#).
3. Release the back door side finisher metal clips using a suitable tool, then remove the back door side finisher.

[]: Metal clip

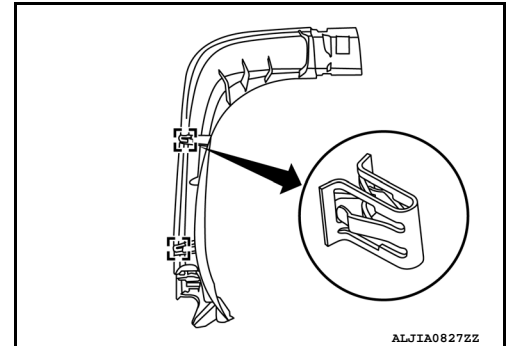

INSTALLATION

Installation is in the reverse order of removal.

CAUTION:

- Visually check the metal clips for deformation and damage during installation. Replace with new ones if necessary.
- When installing back door upper finisher, check that the metal clips are securely placed in body panel holes.

BACK DOOR LOWER FINISHER

BACK DOOR LOWER FINISHER : Removal and Installation

INFOID:000000008507125

REMOVAL

1. Remove the back door pull handle.
2. Remove the back door lower finisher clips (A).

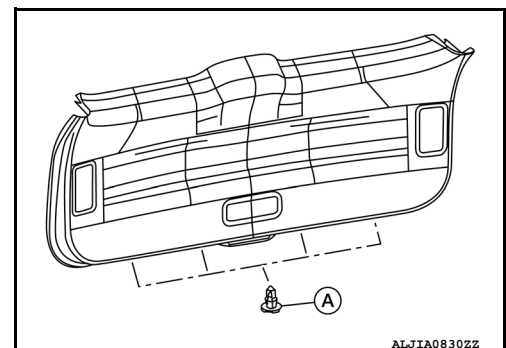

BACK DOOR TRIM

< REMOVAL AND INSTALLATION >

3. Release the back door lower finisher clips using a suitable tool.

△: Clip

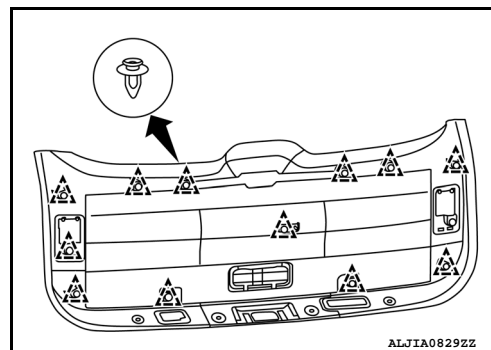

4. Disconnect the harness connectors from the back door lower finisher and remove.

INSTALLATION

Installation is in the reverse order of removal.

CAUTION:

- Visually check the clips for deformation and damage during installation. Replace with new ones if necessary.
- When installing back door finisher, check that clips are securely placed in body panel holes.

BACK DOOR KICKING PLATE

BACK DOOR KICKING PLATE : Removal and Installation

INFOID:000000008507126

REMOVAL

1. Release the back door kicking plate clips and pawls using a suitable tool.

△: Clip
○: Pawl

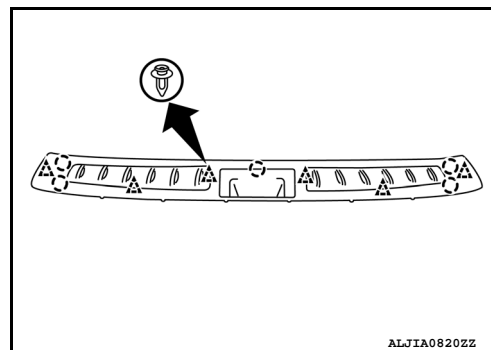

2. Remove the back door kicking plate.

INSTALLATION

Installation is in the reverse order of removal.

CAUTION:

- Visually check the clips and pawls for deformation and damage during installation. Replace with new ones if necessary.
- When installing back door kicking plate, check that clips and pawls are securely placed in body panel holes.