

SECTION **LAN**
LAN SYSTEM

A
B
C
D
E
F
G
H
I
J
K
L

CONTENTS

CAN FUNDAMENTAL		HOW TO USE THIS SECTION	25	
HOW TO USE THIS MANUAL	9	Information	25	
HOW TO USE THIS SECTION	9	Abbreviation List	25	
Information	9	PRECAUTION	26	
PRECAUTION	10	PRECAUTIONS	26	
PRECAUTIONS	10	Precaution for Supplemental Restraint System (SRS) "AIR BAG" and "SEAT BELT PRE-TENSIONER"	26	
Precautions for Trouble Diagnosis	10	Precautions for Trouble Diagnosis	26	
Precautions for Harness Repair	10	Precautions for Harness Repair	26	
SYSTEM DESCRIPTION	11	SYSTEM DESCRIPTION	28	
SYSTEM	11	COMPONENT PARTS	28	
CAN COMMUNICATION SYSTEM	11	Component Parts Location	28	
CAN COMMUNICATION SYSTEM : System Description	11	SYSTEM	29	
DIAG ON CAN	11	CAN COMMUNICATION SYSTEM	29	
DIAG ON CAN : System Description	11	CAN COMMUNICATION SYSTEM : System Description	29	
TROUBLE DIAGNOSIS	13	CAN COMMUNICATION SYSTEM : CAN Communication Control Circuit	34	
Component Description	13	CAN COMMUNICATION SYSTEM : CAN System Specification Chart	34	
Condition of Error Detection	13	CAN COMMUNICATION SYSTEM : CAN Communication Signal Chart	36	
Symptom When Error Occurs in CAN Communication System	14	WIRING DIAGRAM	40	
CAN Diagnosis with CONSULT	16	CAN SYSTEM (WITHOUT AROUND VIEW MONITOR SYSTEM)	40	
Self-Diagnosis	17	Wiring Diagram	40	
CAN Diagnostic Support Monitor	17	CAN SYSTEM (WITH AROUND VIEW MONITOR SYSTEM)	49	
How to Use CAN Communication Signal Chart	19	Wiring Diagram	49	
BASIC INSPECTION	20	BASIC INSPECTION	59	
DIAGNOSIS AND REPAIR WORKFLOW	20	DIAGNOSIS AND REPAIR WORKFLOW	59	
Trouble Diagnosis Flow Chart	20			
Trouble Diagnosis Procedure	20			
CAN				
HOW TO USE THIS MANUAL	25			

LAN

N
O
P

Interview Sheet	59	DLC BRANCH LINE CIRCUIT (CAN COMMUNICATION CIRCUIT 2)	76
DTC/CIRCUIT DIAGNOSIS	60	Diagnosis Procedure	76
MALFUNCTION AREA CHART	60	HVAC BRANCH LINE CIRCUIT	77
Main Line	60	Diagnosis Procedure	77
Branch Line	60	M&A BRANCH LINE CIRCUIT	78
Short Circuit	60	Diagnosis Procedure	78
MAIN LINE BETWEEN IPDM-E AND ABS CIRCUIT	61	SONAR BRANCH LINE CIRCUIT	79
Diagnosis Procedure	61	Diagnosis Procedure	79
MAIN LINE BETWEEN ABS AND DLC CIRCUIT	62	STRG BRANCH LINE CIRCUIT	80
Diagnosis Procedure	62	Diagnosis Procedure	80
MAIN LINE BETWEEN DLC AND 4WD CIRCUIT	63	ADP BRANCH LINE CIRCUIT	81
Diagnosis Procedure	63	Diagnosis Procedure	81
MAIN LINE BETWEEN DLC AND ADP CIRCUIT	64	4WD BRANCH LINE CIRCUIT	82
Diagnosis Procedure	64	Diagnosis Procedure	82
MAIN LINE BETWEEN ADP AND PWBD CIRCUIT	65	PWBD BRANCH LINE CIRCUIT	83
Diagnosis Procedure	65	Diagnosis Procedure	83
MAIN LINE BETWEEN DLC AND CGW CIRCUIT	66	BCM BRANCH LINE CIRCUIT	84
Diagnosis Procedure	66	Diagnosis Procedure	84
ECM BRANCH LINE CIRCUIT	67	CGW BRANCH LINE CIRCUIT (CAN COMMUNICATION CIRCUIT 1)	85
Diagnosis Procedure	67	Diagnosis Procedure	85
IPDM-E BRANCH LINE CIRCUIT	68	CGW BRANCH LINE CIRCUIT (CAN COMMUNICATION CIRCUIT 2)	86
Diagnosis Procedure	68	Diagnosis Procedure	86
TCM BRANCH LINE CIRCUIT	69	AVM BRANCH LINE CIRCUIT	87
Diagnosis Procedure	69	Diagnosis Procedure	87
ABS BRANCH LINE CIRCUIT	70	CAN COMMUNICATION CIRCUIT	88
Diagnosis Procedure	70	Diagnosis Procedure	88
EPS BRANCH LINE CIRCUIT	71	CAN COMMUNICATION CIRCUIT 1	90
Diagnosis Procedure	71	Diagnosis Procedure	90
A-BAG BRANCH LINE CIRCUIT	72	CAN COMMUNICATION CIRCUIT 2	92
Diagnosis Procedure	72	Diagnosis Procedure	92
AV BRANCH LINE CIRCUIT	73	CAN GATEWAY	
Diagnosis Procedure	73	PRECAUTION	94
DLC BRANCH LINE CIRCUIT	74	PRECAUTIONS	94
Diagnosis Procedure	74	Precaution for Supplemental Restraint System (SRS) "AIR BAG" and "SEAT BELT PRE-TENSIONER"	94
DLC BRANCH LINE CIRCUIT (CAN COMMUNICATION CIRCUIT 1)	75	SYSTEM DESCRIPTION	95
Diagnosis Procedure	75	COMPONENT PARTS	95
		Component Parts Location	95
		SYSTEM	96
		System Description	

DIAGNOSIS SYSTEM (CAN GATEWAY)	97	Diagnosis Procedure	111	
CONSULT Function	97			A
ECU DIAGNOSIS INFORMATION	98	IPDM-E BRANCH LINE CIRCUIT	112	
		Diagnosis Procedure	112	
CAN GATEWAY	98	TCM BRANCH LINE CIRCUIT	113	B
Reference Value	98	Diagnosis Procedure	113	
DTC Inspection Priority Chart	98	ABS BRANCH LINE CIRCUIT	114	C
DTC Index	99	Diagnosis Procedure	114	
WIRING DIAGRAM	100	EPS BRANCH LINE CIRCUIT	115	
CAN GATEWAY SYSTEM	100	Diagnosis Procedure	115	D
Wiring Diagram	100	A-BAG BRANCH LINE CIRCUIT	116	
BASIC INSPECTION	102	Diagnosis Procedure	116	E
ADDITIONAL SERVICE WHEN REPLACING		DLC BRANCH LINE CIRCUIT	117	
CAN GATEWAY	102	Diagnosis Procedure	117	F
Description	102	HVAC BRANCH LINE CIRCUIT	118	
Work Procedure	102	Diagnosis Procedure	118	
CONFIGURATION (CAN GATEWAY)	103	M&A BRANCH LINE CIRCUIT	119	G
Work Procedure	103	Diagnosis Procedure	119	
DTC/CIRCUIT DIAGNOSIS	104	STRG BRANCH LINE CIRCUIT	120	H
U1000 CAN COMM CIRCUIT	104	Diagnosis Procedure	120	
Description	104	BCM BRANCH LINE CIRCUIT	121	I
DTC Logic	104	Diagnosis Procedure	121	
Diagnosis Procedure	104	CAN COMMUNICATION CIRCUIT	122	J
U1010 CONTROL UNIT (CAN)	105	Diagnosis Procedure	122	
Description	105	CAN SYSTEM (TYPE 2)		
DTC Logic	105	DTC/CIRCUIT DIAGNOSIS	124	K
Diagnosis Procedure	105	MAIN LINE BETWEEN IPDM-E AND ABS		
B2600 CONFIG ERROR	106	CIRCUIT	124	L
Description	106	Diagnosis Procedure	124	
DTC Logic	106	MAIN LINE BETWEEN ABS AND DLC CIR-		
Diagnosis Procedure	106	CUIT	125	
POWER SUPPLY AND GROUND CIRCUIT ...	107	Diagnosis Procedure	125	LAN
Diagnosis Procedure	107	ECM BRANCH LINE CIRCUIT	126	
REMOVAL AND INSTALLATION	108	Diagnosis Procedure	126	N
CAN GATEWAY	108	IPDM-E BRANCH LINE CIRCUIT	127	
Removal and Installation	108	Diagnosis Procedure	127	
CAN SYSTEM (TYPE 1)		TCM BRANCH LINE CIRCUIT	128	O
DTC/CIRCUIT DIAGNOSIS	109	Diagnosis Procedure	128	
MAIN LINE BETWEEN IPDM-E AND ABS		ABS BRANCH LINE CIRCUIT	129	P
CIRCUIT	109	Diagnosis Procedure	129	
Diagnosis Procedure	109	EPS BRANCH LINE CIRCUIT	130	
MAIN LINE BETWEEN ABS AND DLC CIR-		Diagnosis Procedure	130	
CUIT	110	A-BAG BRANCH LINE CIRCUIT	131	
Diagnosis Procedure	110	Diagnosis Procedure	131	
ECM BRANCH LINE CIRCUIT	111			

AV BRANCH LINE CIRCUIT	132	DLC BRANCH LINE CIRCUIT	152
Diagnosis Procedure	132	Diagnosis Procedure	152
DLC BRANCH LINE CIRCUIT	133	HVAC BRANCH LINE CIRCUIT	153
Diagnosis Procedure	133	Diagnosis Procedure	153
HVAC BRANCH LINE CIRCUIT	134	M&A BRANCH LINE CIRCUIT	154
Diagnosis Procedure	134	Diagnosis Procedure	154
M&A BRANCH LINE CIRCUIT	135	SONAR BRANCH LINE CIRCUIT	155
Diagnosis Procedure	135	Diagnosis Procedure	155
SONAR BRANCH LINE CIRCUIT	136	STRG BRANCH LINE CIRCUIT	156
Diagnosis Procedure	136	Diagnosis Procedure	156
STRG BRANCH LINE CIRCUIT	137	ADP BRANCH LINE CIRCUIT	157
Diagnosis Procedure	137	Diagnosis Procedure	157
BCM BRANCH LINE CIRCUIT	138	PWBD BRANCH LINE CIRCUIT	158
Diagnosis Procedure	138	Diagnosis Procedure	158
CAN COMMUNICATION CIRCUIT	139	BCM BRANCH LINE CIRCUIT	159
Diagnosis Procedure	139	Diagnosis Procedure	159
CAN SYSTEM (TYPE 3)		CAN COMMUNICATION CIRCUIT	160
DTC/CIRCUIT DIAGNOSIS	141	Diagnosis Procedure	160
MAIN LINE BETWEEN IPDM-E AND ABS		CAN SYSTEM (TYPE 4)	
CIRCUIT	141	DTC/CIRCUIT DIAGNOSIS	162
Diagnosis Procedure	141	MAIN LINE BETWEEN IPDM-E AND ABS	
MAIN LINE BETWEEN ABS AND DLC CIR-		CIRCUIT	162
CUIT	142	Diagnosis Procedure	162
Diagnosis Procedure	142	MAIN LINE BETWEEN ABS AND DLC CIR-	
MAIN LINE BETWEEN DLC AND ADP CIR-		CUIT	163
CUIT	143	Diagnosis Procedure	163
Diagnosis Procedure	143	MAIN LINE BETWEEN DLC AND ADP CIR-	
MAIN LINE BETWEEN ADP AND PWBD CIR-		CUIT	164
CUIT	144	Diagnosis Procedure	164
Diagnosis Procedure	144	MAIN LINE BETWEEN ADP AND PWBD CIR-	
ECM BRANCH LINE CIRCUIT	145	CUIT	165
Diagnosis Procedure	145	Diagnosis Procedure	165
IPDM-E BRANCH LINE CIRCUIT	146	MAIN LINE BETWEEN DLC AND CGW CIR-	
Diagnosis Procedure	146	CUIT	166
TCM BRANCH LINE CIRCUIT	147	Diagnosis Procedure	166
Diagnosis Procedure	147	ECM BRANCH LINE CIRCUIT	167
ABS BRANCH LINE CIRCUIT	148	Diagnosis Procedure	167
Diagnosis Procedure	148	IPDM-E BRANCH LINE CIRCUIT	168
EPS BRANCH LINE CIRCUIT	149	Diagnosis Procedure	168
Diagnosis Procedure	149	TCM BRANCH LINE CIRCUIT	169
A-BAG BRANCH LINE CIRCUIT	150	Diagnosis Procedure	169
Diagnosis Procedure	150	ABS BRANCH LINE CIRCUIT	170
AV BRANCH LINE CIRCUIT	151	Diagnosis Procedure	170
Diagnosis Procedure	151	EPS BRANCH LINE CIRCUIT	171

Diagnosis Procedure	171	Diagnosis Procedure	191
A-BAG BRANCH LINE CIRCUIT	172	MAIN LINE BETWEEN DLC AND 4WD CIR-	192
Diagnosis Procedure	172	CUIT	192
AV BRANCH LINE CIRCUIT	173	Diagnosis Procedure	192
Diagnosis Procedure	173	ECM BRANCH LINE CIRCUIT	193
DLC BRANCH LINE CIRCUIT (CAN COMMU-	174	Diagnosis Procedure	193
UNICATION CIRCUIT 1)	174	IPDM-E BRANCH LINE CIRCUIT	194
Diagnosis Procedure	174	Diagnosis Procedure	194
DLC BRANCH LINE CIRCUIT (CAN COMMU-	175	TCM BRANCH LINE CIRCUIT	195
UNICATION CIRCUIT 2)	175	Diagnosis Procedure	195
Diagnosis Procedure	175	ABS BRANCH LINE CIRCUIT	196
HVAC BRANCH LINE CIRCUIT	176	Diagnosis Procedure	196
Diagnosis Procedure	176	EPS BRANCH LINE CIRCUIT	197
M&A BRANCH LINE CIRCUIT	177	Diagnosis Procedure	197
Diagnosis Procedure	177	A-BAG BRANCH LINE CIRCUIT	198
SONAR BRANCH LINE CIRCUIT	178	Diagnosis Procedure	198
Diagnosis Procedure	178	DLC BRANCH LINE CIRCUIT	199
STRG BRANCH LINE CIRCUIT	179	Diagnosis Procedure	199
Diagnosis Procedure	179	HVAC BRANCH LINE CIRCUIT	200
ADP BRANCH LINE CIRCUIT	180	Diagnosis Procedure	200
Diagnosis Procedure	180	M&A BRANCH LINE CIRCUIT	201
PWBD BRANCH LINE CIRCUIT	181	Diagnosis Procedure	201
Diagnosis Procedure	181	STRG BRANCH LINE CIRCUIT	202
BCM BRANCH LINE CIRCUIT	182	Diagnosis Procedure	202
Diagnosis Procedure	182	4WD BRANCH LINE CIRCUIT	203
CGW BRANCH LINE CIRCUIT (CAN COM-	183	Diagnosis Procedure	203
MUNICATION CIRCUIT 1)	183	BCM BRANCH LINE CIRCUIT	204
Diagnosis Procedure	183	Diagnosis Procedure	204
CGW BRANCH LINE CIRCUIT (CAN COM-	184	CAN COMMUNICATION CIRCUIT	205
MUNICATION CIRCUIT 2)	184	Diagnosis Procedure	205
Diagnosis Procedure	184	CAN SYSTEM (TYPE 6)	
AVM BRANCH LINE CIRCUIT	185	DTC/CIRCUIT DIAGNOSIS	207
Diagnosis Procedure	185	MAIN LINE BETWEEN IPDM-E AND ABS	
CAN COMMUNICATION CIRCUIT 1	186	CIRCUIT	207
Diagnosis Procedure	186	Diagnosis Procedure	207
CAN COMMUNICATION CIRCUIT 2	188	MAIN LINE BETWEEN ABS AND DLC CIR-	208
Diagnosis Procedure	188	CUIT	208
CAN SYSTEM (TYPE 5)		Diagnosis Procedure	208
DTC/CIRCUIT DIAGNOSIS	190	MAIN LINE BETWEEN DLC AND 4WD CIR-	209
MAIN LINE BETWEEN IPDM-E AND ABS		CUIT	209
CIRCUIT	190	Diagnosis Procedure	209
Diagnosis Procedure	190	ECM BRANCH LINE CIRCUIT	210
MAIN LINE BETWEEN ABS AND DLC CIR-	191	Diagnosis Procedure	210
CUIT	191		

A
B
C
D
E
F
G
H
I
J
K
L
LAN
N
O
P

IPDM-E BRANCH LINE CIRCUIT	211	TCM BRANCH LINE CIRCUIT	231
Diagnosis Procedure	211	Diagnosis Procedure	231
TCM BRANCH LINE CIRCUIT	212	ABS BRANCH LINE CIRCUIT	232
Diagnosis Procedure	212	Diagnosis Procedure	232
ABS BRANCH LINE CIRCUIT	213	EPS BRANCH LINE CIRCUIT	233
Diagnosis Procedure	213	Diagnosis Procedure	233
EPS BRANCH LINE CIRCUIT	214	A-BAG BRANCH LINE CIRCUIT	234
Diagnosis Procedure	214	Diagnosis Procedure	234
A-BAG BRANCH LINE CIRCUIT	215	AV BRANCH LINE CIRCUIT	235
Diagnosis Procedure	215	Diagnosis Procedure	235
AV BRANCH LINE CIRCUIT	216	DLC BRANCH LINE CIRCUIT	236
Diagnosis Procedure	216	Diagnosis Procedure	236
DLC BRANCH LINE CIRCUIT	217	HVAC BRANCH LINE CIRCUIT	237
Diagnosis Procedure	217	Diagnosis Procedure	237
HVAC BRANCH LINE CIRCUIT	218	M&A BRANCH LINE CIRCUIT	238
Diagnosis Procedure	218	Diagnosis Procedure	238
M&A BRANCH LINE CIRCUIT	219	SONAR BRANCH LINE CIRCUIT	239
Diagnosis Procedure	219	Diagnosis Procedure	239
SONAR BRANCH LINE CIRCUIT	220	STRG BRANCH LINE CIRCUIT	240
Diagnosis Procedure	220	Diagnosis Procedure	240
STRG BRANCH LINE CIRCUIT	221	4WD BRANCH LINE CIRCUIT	241
Diagnosis Procedure	221	Diagnosis Procedure	241
4WD BRANCH LINE CIRCUIT	222	PWBD BRANCH LINE CIRCUIT	242
Diagnosis Procedure	222	Diagnosis Procedure	242
BCM BRANCH LINE CIRCUIT	223	BCM BRANCH LINE CIRCUIT	243
Diagnosis Procedure	223	Diagnosis Procedure	243
CAN COMMUNICATION CIRCUIT	224	CAN COMMUNICATION CIRCUIT	244
Diagnosis Procedure	224	Diagnosis Procedure	244
CAN SYSTEM (TYPE 7)		CAN SYSTEM (TYPE 8)	
DTC/CIRCUIT DIAGNOSIS	226	DTC/CIRCUIT DIAGNOSIS	246
MAIN LINE BETWEEN IPDM-E AND ABS CIRCUIT	226	MAIN LINE BETWEEN IPDM-E AND ABS CIRCUIT	246
Diagnosis Procedure	226	Diagnosis Procedure	246
MAIN LINE BETWEEN ABS AND DLC CIRCUIT	227	MAIN LINE BETWEEN ABS AND DLC CIRCUIT	247
Diagnosis Procedure	227	Diagnosis Procedure	247
MAIN LINE BETWEEN DLC AND 4WD CIRCUIT	228	MAIN LINE BETWEEN DLC AND ADP CIRCUIT	248
Diagnosis Procedure	228	Diagnosis Procedure	248
ECM BRANCH LINE CIRCUIT	229	MAIN LINE BETWEEN ADP AND PWBD CIRCUIT	249
Diagnosis Procedure	229	Diagnosis Procedure	249
IPDM-E BRANCH LINE CIRCUIT	230	ECM BRANCH LINE CIRCUIT	250
Diagnosis Procedure	230	Diagnosis Procedure	250

IPDM-E BRANCH LINE CIRCUIT	251	MAIN LINE BETWEEN ADP AND PWBD CIRCUIT	271	A
Diagnosis Procedure	251	Diagnosis Procedure	271	
TCM BRANCH LINE CIRCUIT	252	MAIN LINE BETWEEN DLC AND CGW CIRCUIT	272	B
Diagnosis Procedure	252	Diagnosis Procedure	272	
ABS BRANCH LINE CIRCUIT	253	ECM BRANCH LINE CIRCUIT	273	C
Diagnosis Procedure	253	Diagnosis Procedure	273	
EPS BRANCH LINE CIRCUIT	254	IPDM-E BRANCH LINE CIRCUIT	274	D
Diagnosis Procedure	254	Diagnosis Procedure	274	
A-BAG BRANCH LINE CIRCUIT	255	TCM BRANCH LINE CIRCUIT	275	E
Diagnosis Procedure	255	Diagnosis Procedure	275	
AV BRANCH LINE CIRCUIT	256	ABS BRANCH LINE CIRCUIT	276	F
Diagnosis Procedure	256	Diagnosis Procedure	276	
DLC BRANCH LINE CIRCUIT	257	EPS BRANCH LINE CIRCUIT	277	G
Diagnosis Procedure	257	Diagnosis Procedure	277	
HVAC BRANCH LINE CIRCUIT	258	A-BAG BRANCH LINE CIRCUIT	278	H
Diagnosis Procedure	258	Diagnosis Procedure	278	
M&A BRANCH LINE CIRCUIT	259	AV BRANCH LINE CIRCUIT	279	I
Diagnosis Procedure	259	Diagnosis Procedure	279	
SONAR BRANCH LINE CIRCUIT	260	DLC BRANCH LINE CIRCUIT (CAN COMMUNICATION CIRCUIT 1)	280	J
Diagnosis Procedure	260	Diagnosis Procedure	280	
STRG BRANCH LINE CIRCUIT	261	DLC BRANCH LINE CIRCUIT (CAN COMMUNICATION CIRCUIT 2)	281	K
Diagnosis Procedure	261	Diagnosis Procedure	281	
ADP BRANCH LINE CIRCUIT	262	HVAC BRANCH LINE CIRCUIT	282	L
Diagnosis Procedure	262	Diagnosis Procedure	282	
4WD BRANCH LINE CIRCUIT	263	M&A BRANCH LINE CIRCUIT	283	LAN
Diagnosis Procedure	263	Diagnosis Procedure	283	
PWBD BRANCH LINE CIRCUIT	264	SONAR BRANCH LINE CIRCUIT	284	N
Diagnosis Procedure	264	Diagnosis Procedure	284	
BCM BRANCH LINE CIRCUIT	265	STRG BRANCH LINE CIRCUIT	285	O
Diagnosis Procedure	265	Diagnosis Procedure	285	
CAN COMMUNICATION CIRCUIT	266	ADP BRANCH LINE CIRCUIT	286	P
Diagnosis Procedure	266	Diagnosis Procedure	286	
CAN SYSTEM (TYPE 9)		4WD BRANCH LINE CIRCUIT	287	
DTC/CIRCUIT DIAGNOSIS	268	Diagnosis Procedure	287	
MAIN LINE BETWEEN IPDM-E AND ABS CIRCUIT	268	PWBD BRANCH LINE CIRCUIT	288	
Diagnosis Procedure	268	Diagnosis Procedure	288	
MAIN LINE BETWEEN ABS AND DLC CIRCUIT	269	BCM BRANCH LINE CIRCUIT	289	
Diagnosis Procedure	269	Diagnosis Procedure	289	
MAIN LINE BETWEEN DLC AND ADP CIRCUIT	270	CGW BRANCH LINE CIRCUIT (CAN COMMUNICATION CIRCUIT 1)	290	
Diagnosis Procedure	270			

Diagnosis Procedure	290	Diagnosis Procedure	292
CGW BRANCH LINE CIRCUIT (CAN COM- MUNICATION CIRCUIT 2)	291	CAN COMMUNICATION CIRCUIT 1	293
Diagnosis Procedure	291	Diagnosis Procedure	293
AVM BRANCH LINE CIRCUIT	292	CAN COMMUNICATION CIRCUIT 2	295
		Diagnosis Procedure	295

HOW TO USE THIS MANUAL

HOW TO USE THIS SECTION

Information

INFOID:000000008510068

- “CAN FUNDAMENTAL” of LAN Section describes the basic knowledge of the CAN communication system and the method of trouble diagnosis.
- For information peculiar to a vehicle and inspection procedure, refer to “CAN”.

A
B
C
D
E
F
G
H
I
J
K
L
LAN
N
O
P

PRECAUTION

PRECAUTIONS

Precautions for Trouble Diagnosis

INFOID:000000008510069

CAUTION:

Follow the instructions listed below. Failure to do this may cause damage to parts:

- Never apply 7.0 V or more to the measurement terminal.
- Use a tester with open terminal voltage of 7.0 V or less.
- Turn the ignition switch OFF and disconnect the battery cable from the negative terminal when checking the harness.

Precautions for Harness Repair

INFOID:000000008510070

- Solder the repaired area and wrap tape around the soldered area.

NOTE:

A fray of twisted lines must be within 110 mm (4.33 in).

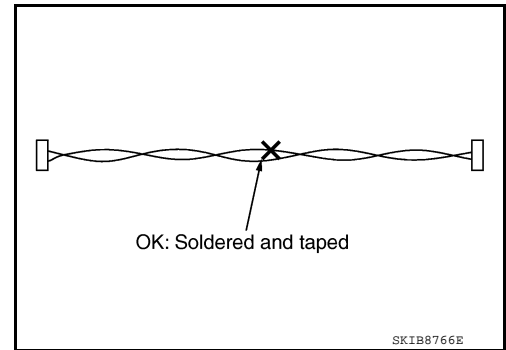

- Bypass connection is never allowed at the repaired area.

NOTE:

Bypass connection may cause CAN communication error. The spliced wire becomes separated and the characteristics of twisted line are lost.

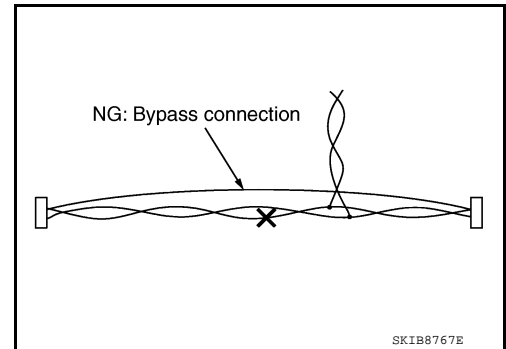

- Replace the applicable harness as an assembly if error is detected on the shield lines of CAN communication line.

SYSTEM DESCRIPTION

SYSTEM

CAN COMMUNICATION SYSTEM

CAN COMMUNICATION SYSTEM : System Description

INFOID:000000008510071

CAN (Controller Area Network) is a serial communication line for real time application. It is an on-vehicle multiplex communication line with high data communication speed and excellent error detection ability. Many electronic control units are equipped onto a vehicle, and each control unit shares information and links with other control units during operation (not independent). In CAN communication, control units are connected with 2 communication lines (CAN-H line, CAN-L line) allowing a high rate of information transmission with less wiring. Each control unit transmits/receives data but selectively reads required data only.

DIAG ON CAN

DIAG ON CAN : System Description

INFOID:000000008510072

SYSTEM DIAGRAM

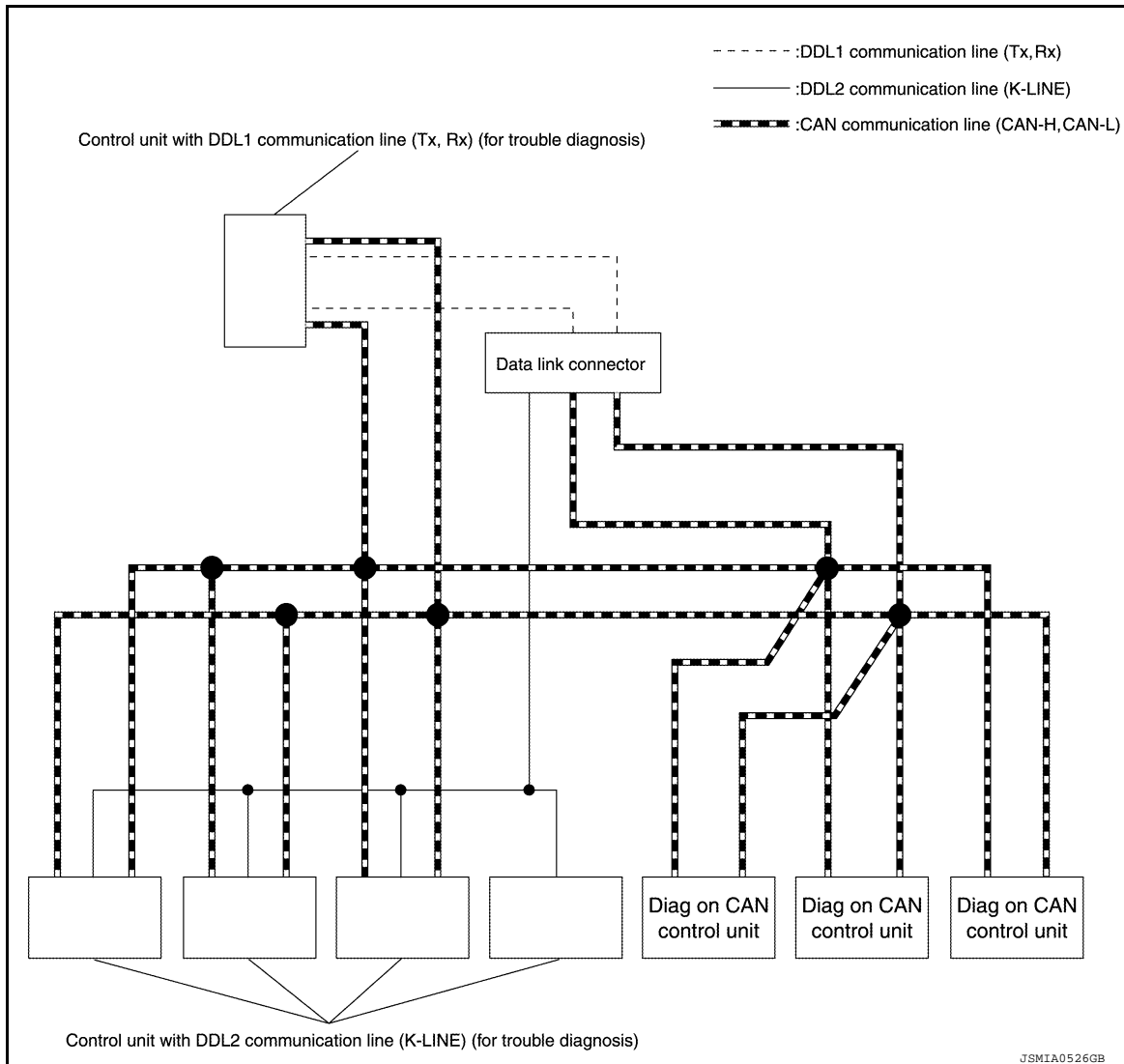

A
B
C
D
E
F
G
H
I
J
K
L
N
O
P

LAN

SYSTEM

< SYSTEM DESCRIPTION >

[CAN FUNDAMENTAL]

Name	Harness	Description
DDL1	Tx Rx	For communications with the diagnostic tool. (CAN-H and CAN-L are used for controlling)
DDL2	K-LINE	For communications with the diagnostic tool. (CAN-H and CAN-L are used for controlling)
Diag on CAN	CAN-H CAN-L	For communications with the diagnostic tool. (CAN-H and CAN-L are also used for control and diagnoses.)

DESCRIPTION

“Diag on CAN” is a diagnosis method which uses the CAN communication line for the communication between the control unit and the diagnostic tool.

TROUBLE DIAGNOSIS

Component Description

INFOID:000000008510073

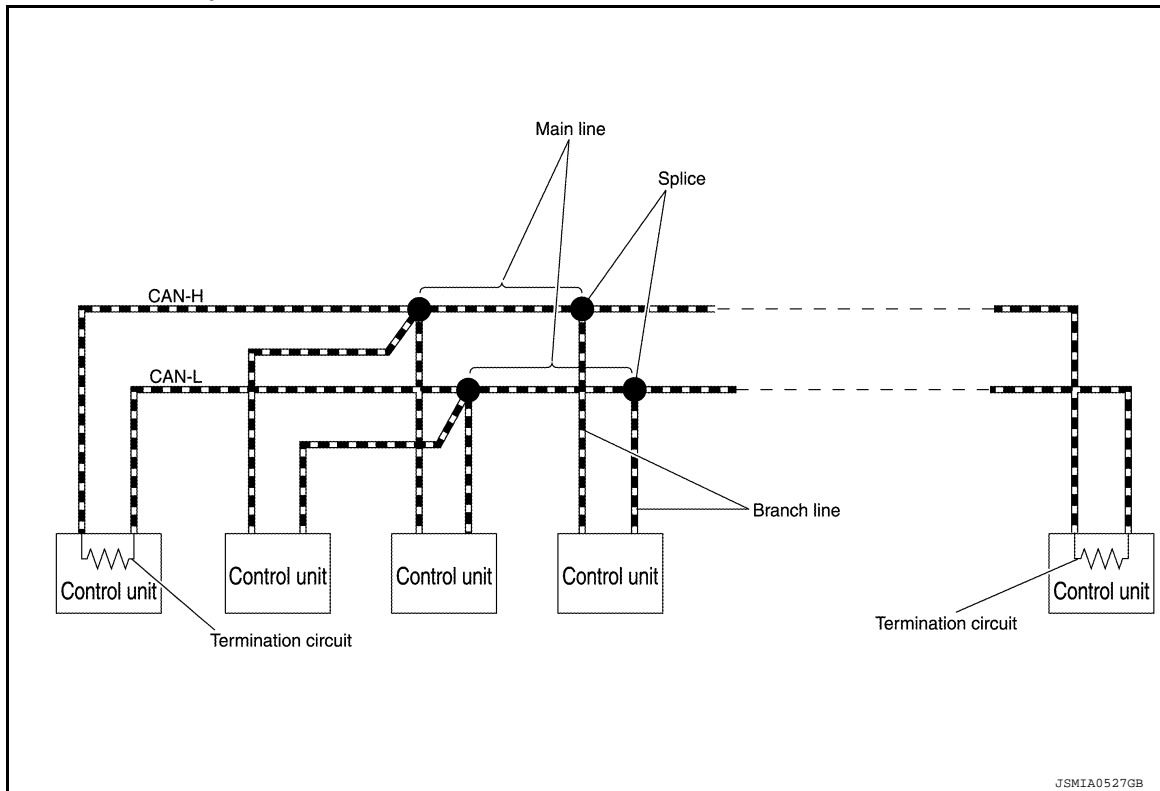

JSMIA0527GB

Component	Description
Main line	CAN communication line between splices
Branch line	CAN communication line between splice and a control unit
Splice	A point connecting a branch line with a main line
Termination circuit	Circuit connected across the CAN communication system. (Resistor)

Condition of Error Detection

INFOID:000000008510074

DTC (e.g. U1000 and U1001) of CAN communication is indicated on SELF-DIAG RESULTS on CONSULT if a CAN communication signal is not transmitted or received between units for 2 seconds or more.

CAN COMMUNICATION SYSTEM ERROR

- CAN communication line open (CAN-H, CAN-L, or both)
- CAN communication line short (ground, between CAN communication lines, other harnesses)
- Error of CAN communication control circuit of the unit connected to CAN communication line

WHEN DTC OF CAN COMMUNICATION IS INDICATED EVEN THOUGH CAN COMMUNICATION SYSTEM IS NORMAL

- Removal/installation of parts: Error may be detected when removing and installing CAN communication unit and related parts while turning the ignition switch ON. (A DTC except for CAN communication may be detected.)
- Fuse blown out (removed): CAN communication of the unit may cease.
- Voltage drop: Error may be detected if voltage drops due to discharged battery when turning the ignition switch ON (Depending on the control unit which carries out CAN communication).
- Error may be detected if the power supply circuit of the control unit, which carries out CAN communication, malfunctions (Depending on the control unit which carries out CAN communication).
- Error may be detected if reprogramming is not completed normally.

NOTE:

CAN communication system is normal if DTC of CAN communication is indicated on SELF-DIAG RESULTS of CONSULT under the above conditions. Erase the memory of the self-diagnosis of each control unit.

A
B
C
D
E
F
G
H
I
J
K
L

LAN

N
O
P

TROUBLE DIAGNOSIS

< SYSTEM DESCRIPTION >

[CAN FUNDAMENTAL]

Symptom When Error Occurs in CAN Communication System

INFOID:000000008510075

In CAN communication system, multiple control units mutually transmit and receive signals. Each control unit cannot transmit and receive signals if any error occurs on CAN communication line. Under this condition, multiple control units related to the root cause malfunction or go into fail-safe mode.

ERROR EXAMPLE

NOTE:

Each vehicle differs in symptom of each control unit under fail-safe mode and CAN communication line wiring.

Example: Main Line Between Data Link Connector and ABS Actuator and Electric Unit (Control Unit) Open Circuit

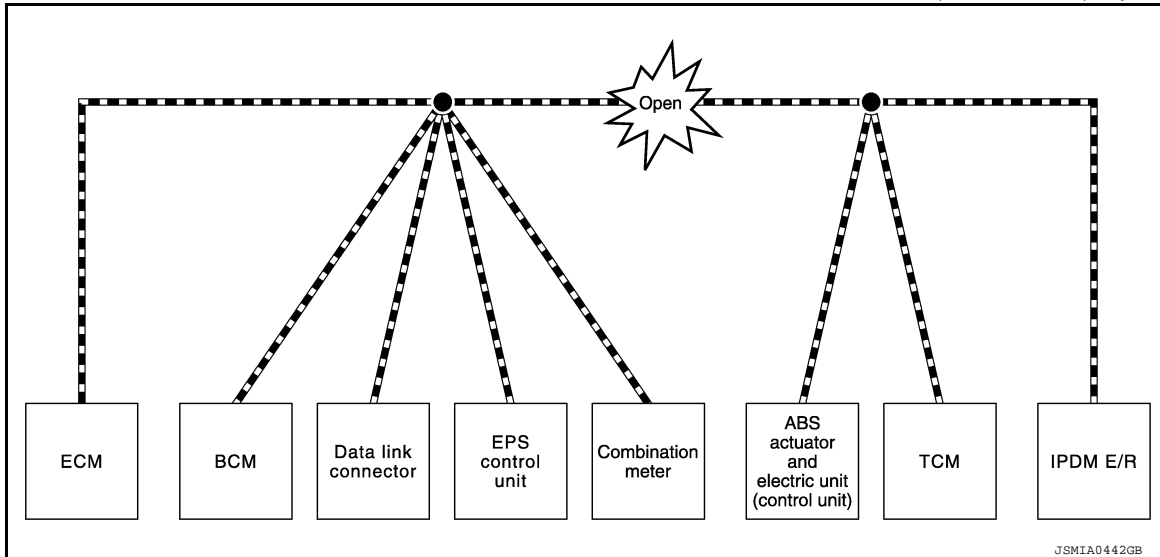

Unit name	Major symptom
ECM	Engine torque limiting is affected, and shift harshness increases.
BCM	<ul style="list-style-type: none"> • Reverse warning buzzer does not sound. • The front wiper moves under continuous operation mode even though the front wiper switch being in the intermittent position.
EPS control unit	The steering effort increases.
Combination meter	<ul style="list-style-type: none"> • The shift position indicator and OD OFF indicator turn OFF. • The speedometer is inoperative. • The odo/trip meter stops.
ABS actuator and electric unit (control unit)	Normal operation.
TCM	No impact on operation.
IPDM E/R	When the ignition switch is ON, <ul style="list-style-type: none"> • The headlamps (Lo) turn ON. • The cooling fan continues to rotate.

TROUBLE DIAGNOSIS

< SYSTEM DESCRIPTION >

[CAN FUNDAMENTAL]

Example: TCM Branch Line Open Circuit

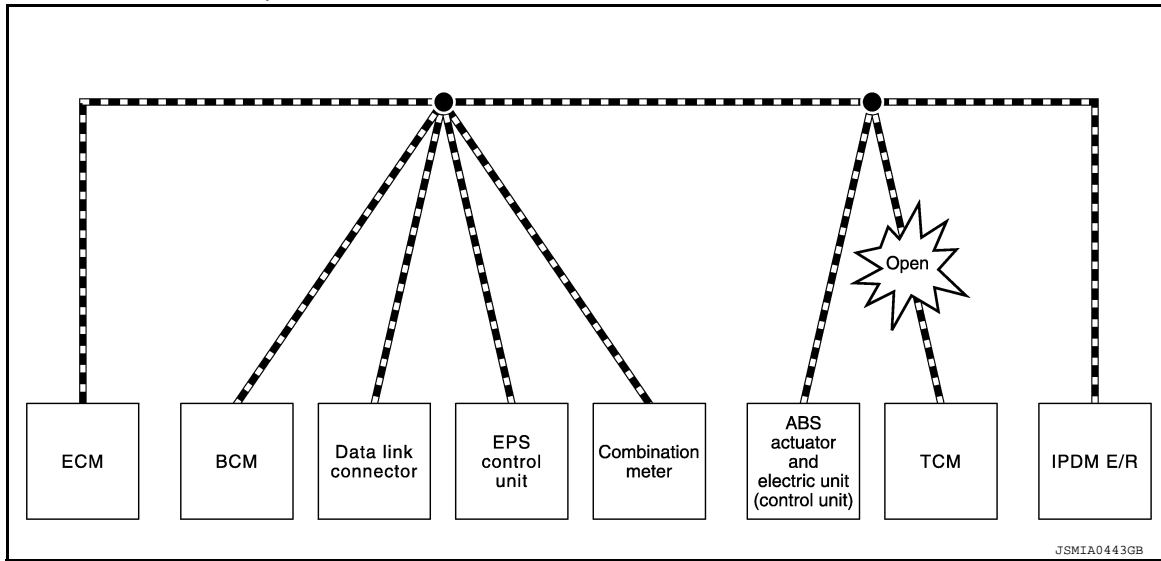

Unit name	Major symptom
ECM	Engine torque limiting is affected, and shift harshness increases.
BCM	Reverse warning buzzer does not sound.
EPS control unit	Normal operation.
Combination meter	<ul style="list-style-type: none"> Shift position indicator and O/D OFF indicator turn OFF. Warning lamps turn ON.
ABS actuator and electric unit (control unit)	Normal operation.
TCM	No impact on operation.
IPDM E/R	Normal operation.

NOTE:

The model (all control units on CAN communication system are Diag on CAN) cannot perform CAN diagnosis with CONSULT if the following error occurs. The error is judged by the symptom.

Error	Difference of symptom
Data link connector branch line open circuit	Normal operation.
CAN-H, CAN-L harness short-circuit	Most of the control units which are connected to the CAN communication system enter fail-safe mode or are deactivated.

Example: Data Link Connector Branch Line Open Circuit

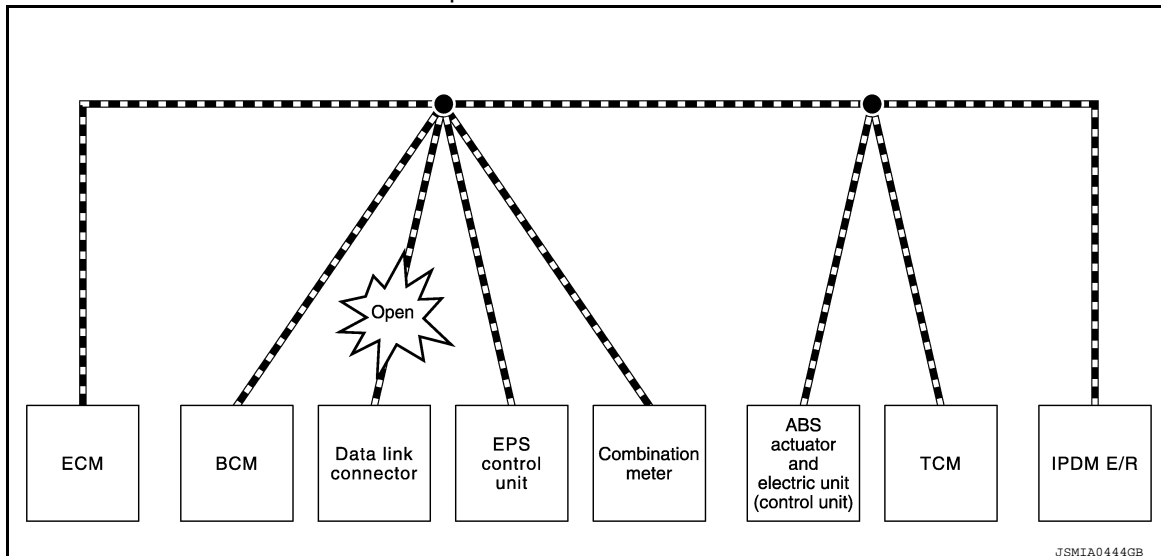

A
B
C
D
E
F
G
H
I
J
K
L
N
O
P

LAN

TROUBLE DIAGNOSIS

< SYSTEM DESCRIPTION >

[CAN FUNDAMENTAL]

Unit name	Major symptom
ECM	Normal operation.
BCM	
EPS control unit	
Combination meter	
ABS actuator and electric unit (control unit)	
TCM	
IPDM E/R	

NOTE:

When data link connector branch line is open, transmission and reception of CAN communication signals are not affected. Therefore, no symptoms occur. However, be sure to repair malfunctioning circuit.

Example: CAN-H, CAN-L Harness Short Circuit

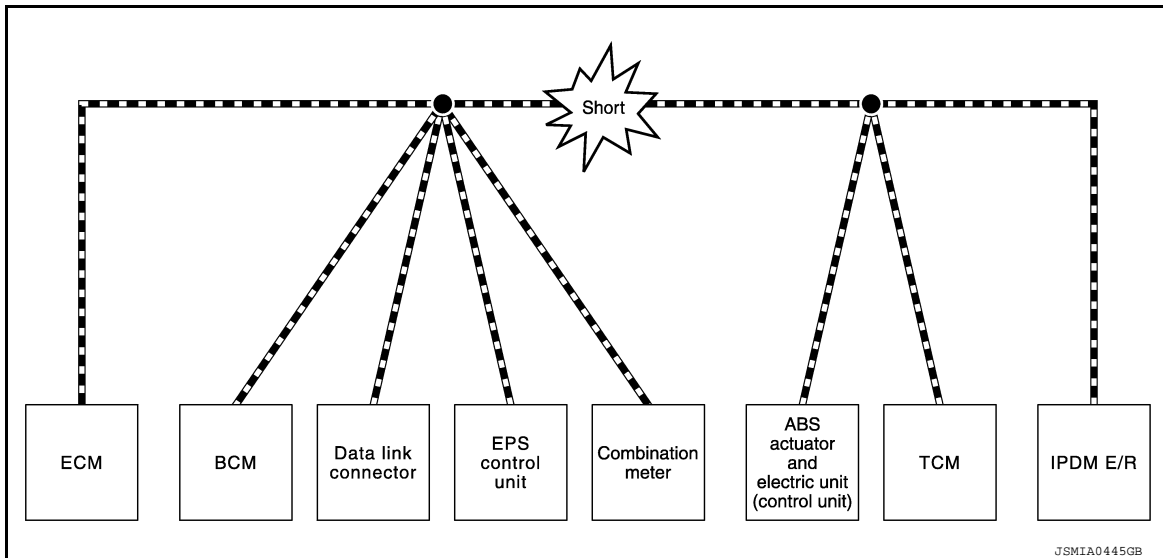

Unit name	Major symptom
ECM	<ul style="list-style-type: none"> • Engine torque limiting is affected, and shift harshness increases. • Engine speed drops.
BCM	<ul style="list-style-type: none"> • Reverse warning buzzer does not sound. • The front wiper moves under continuous operation mode even though the front wiper switch being in the intermittent position. • The room lamp does not turn ON. • The engine does not start (if an error or malfunction occurs while turning the ignition switch OFF.) • The steering lock does not release (if an error or malfunction occurs while turning the ignition switch OFF.)
EPS control unit	The steering effort increases.
Combination meter	<ul style="list-style-type: none"> • The tachometer and the speedometer do not move. • Warning lamps turn ON. • Indicator lamps do not turn ON.
ABS actuator and electric unit (control unit)	Normal operation.
TCM	No impact on operation.
IPDM E/R	When the ignition switch is ON, <ul style="list-style-type: none"> • The headlamps (Lo) turn ON. • The cooling fan continues to rotate.

CAN Diagnosis with CONSULT

INFOID:000000008510076

CAN diagnosis on CONSULT extracts the root cause by receiving the following information.

TROUBLE DIAGNOSIS

[CAN FUNDAMENTAL]

< SYSTEM DESCRIPTION >

- Response to the system call
- Control unit diagnosis information
- Self-diagnosis
- CAN diagnostic support monitor

Self-Diagnosis

INFOID:000000008510077

If communication signals cannot be transmitted or received among control units communicating via CAN communication line, CAN communication-related DTC is displayed on the CONSULT "Self Diagnostic Result" screen.

NOTE:

The following table shows examples of CAN communication-related DTC. For other DTC, refer to the applicable sections.

DTC	Self-diagnosis item (CONSULT indication)	DTC detection condition		Inspection/Action
U1000	CAN COMM CIRCUIT	ECM	When ECM is not transmitting or receiving CAN communication signal of OBD (emission-related diagnosis) for 2 seconds or more.	Start the inspection. Refer to the applicable section of the indicated control unit.
		Except for ECM	When a control unit (except for ECM) is not transmitting or receiving CAN communication signal for 2 seconds or more.	
U1001	CAN COMM CIRCUIT	When ECM is not transmitting or receiving CAN communication signal other than OBD (emission-related diagnosis) for 2 seconds or more.		
U1002	SYSTEM COMM	When a control unit is not transmitting or receiving CAN communication signal for 2 seconds or less.		
U1010	CONTROL UNIT(CAN)	When an error is detected during the initial diagnosis for CAN controller of each control unit.		

CAN Diagnostic Support Monitor

INFOID:000000008510078

MONITOR ITEM (CONSULT)

Example: CAN DIAG SUPPORT MNTR indication

Without PAST				With PAST			
BCM				ENGINE			
MONITOR ITEM	PRESENT	PAST		MONITOR ITEM	PRESENT	PAST	
INITIAL DIAG	OK	-		TRANSMIT DIAG	OK	OK	
TRANSMIT DIAG	OK	-		VDC/TCS/ABS	OK	5	
ECM	OK	-		METER/M&A	Not diagnosed	-	
METER/M&A	OK	-		BCM/SEC	OK	OK	
TCM	OK	-		ICC	Not diagnosed	-	
IPDM E/R	OK	-		HVAC	Not diagnosed	-	
I-KEY	OK	-		TCM	OK	OK	
				EPS	OK	OK	
				IPDM E/R	OK	5	
				e4WD	Not diagnosed	-	
				AWD/4WD	Not diagnosed	-	

JSMIA0964GB

Without PAST

Item	PRESENT	Description
Initial diagnosis	OK	Normal at present
	NG	Control unit error (Except for some control units)

TROUBLE DIAGNOSIS

< SYSTEM DESCRIPTION >

[CAN FUNDAMENTAL]

Item	PRESENT	Description
Transmission diagnosis	OK	Normal at present
	UNKWN	Unable to transmit signals for 2 seconds or more.
		Diagnosis not performed
Control unit name (Reception diagnosis)	OK	Normal at present
	UNKWN	Unable to receive signals for 2 seconds or more.
		Diagnosis not performed
		No control unit for receiving signals. (No applicable optional parts)

With PAST

Item	PRESENT	PAST	Description
Transmission diagnosis	OK	OK	Normal at present and in the past
		1 – 39	Normal at present, but unable to transmit signals for 2 seconds or more in the past. (The number indicates the number of ignition switch cycles from OFF to ON.)
	UNKWN	0	Unable to transmit signals for 2 seconds or more at present.
Control unit name (Reception diagnosis)	OK	OK	Normal at present and in the past
		1 – 39	Normal at present, but unable to receive signals for 2 seconds or more in the past. (The number indicates the number of ignition switch cycles from OFF to ON.)
	UNKWN	0	Unable to receive signals for 2 seconds or more at present.
	Not diagnosed	-	-
-			No control unit for receiving signals. (No applicable optional parts)

TROUBLE DIAGNOSIS

< SYSTEM DESCRIPTION >

[CAN FUNDAMENTAL]

How to Use CAN Communication Signal Chart

INFOID:000000008510079

The CAN communication signal chart lists the signals transmitted/received among control units. It is useful for detecting the root cause by finding a signal related to the symptom, and by checking transmission and reception unit.

Example: Tachometer does not move even though the engine rotates.

T: Transmit R: Receive

Signal name/Connecting unit	ECM	BCM	M&A	STRG	ABS	IPDM-E
A/C compressor feedback signal	T		R			
A/C compressor request signal	T					R
Accelerator pedal position signal	T				R	
Cooling fan motor operation signal	T					R
Engine coolant temperature signal	T		R			
Engine speed signal	T		R		R	
Fuel consumption monitor signal	T		R			
Malfunction indicator lamp signal	T		R			
A/C switch signal	R	T				
Ignition switch signal		T				R
Sleep/wake up signal		T	R			R

It indicates that an error occurs between ECM and Combination meter (Shaded area).

JSMIA0446GB

A
B
C
D
E
F
G
H
I
J
K
L
N
O
P

LAN

BASIC INSPECTION

DIAGNOSIS AND REPAIR WORKFLOW

Trouble Diagnosis Flow Chart

INFOID:000000008510080

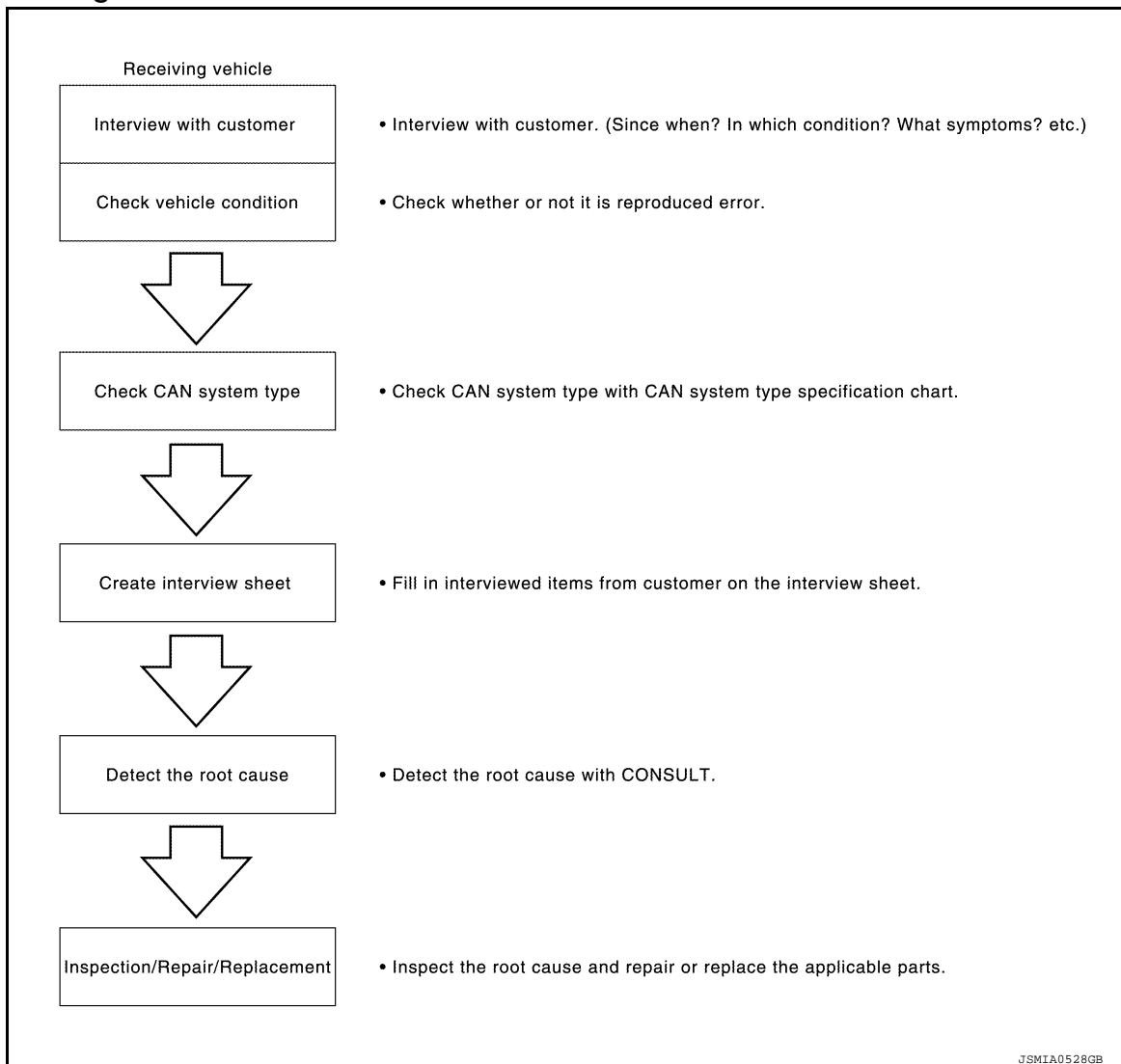

Trouble Diagnosis Procedure

INFOID:000000008510081

INTERVIEW WITH CUSTOMER

Interview with the customer is important to detect the root cause of CAN communication system errors and to understand vehicle condition and symptoms for proper trouble diagnosis.

Points in interview

- What: Parts name, system name
- When: Date, Frequency
- Where: Road condition, Place
- In what condition: Driving condition/environment
- Result: Symptom

Notes for checking error symptoms:

- Check normal units as well as error symptoms.
- Example: Circuit between ECM and the combination meter is judged normal if the customer indicates tachometer functions normally.
- When a CAN communication system error is present, multiple control units may malfunction or go into fail-safe mode.

DIAGNOSIS AND REPAIR WORKFLOW

< BASIC INSPECTION >

[CAN FUNDAMENTAL]

- Indication of the combination meter is important to detect the root cause because it is the most obvious to the customer, and it performs CAN communication with many units.

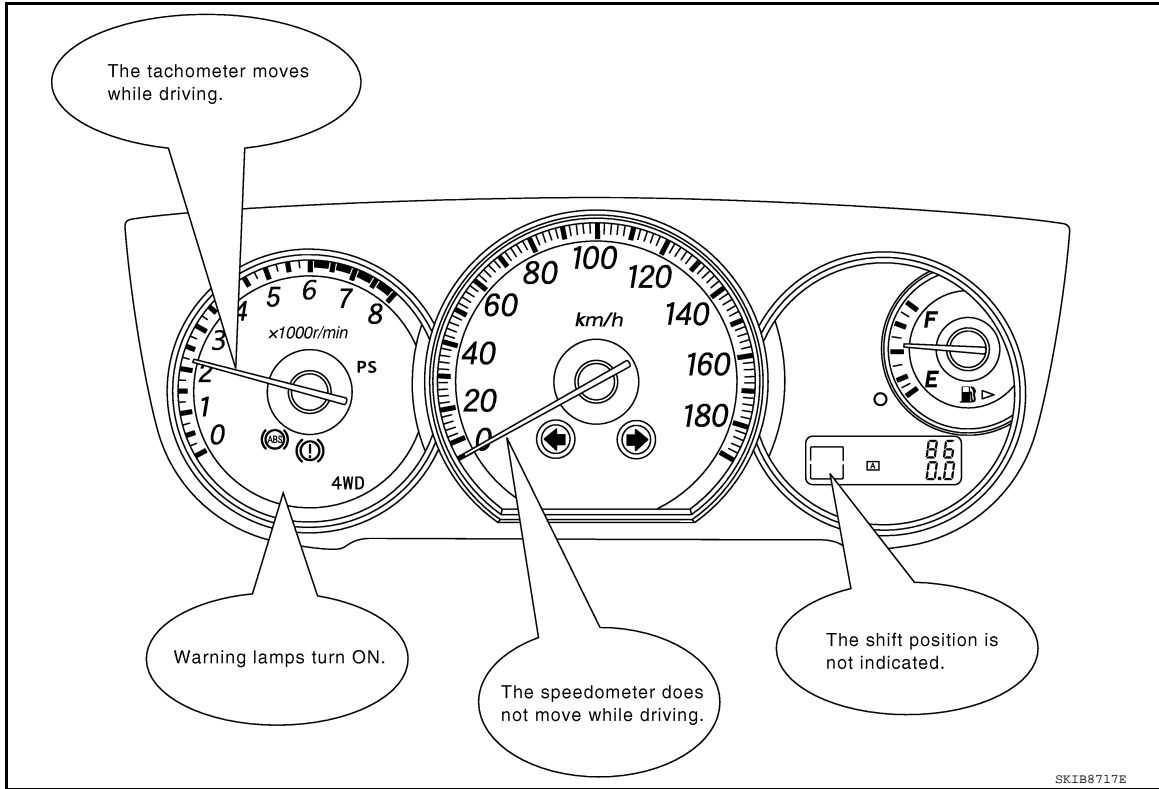

INSPECTION OF VEHICLE CONDITION

Check whether the symptom is reproduced or not.

NOTE:

Do not turn the ignition switch OFF or disconnect the battery cable while reproducing the error. The error may temporarily correct itself, making it difficult to determine the root cause.

CHECK OF CAN SYSTEM TYPE (HOW TO USE CAN SYSTEM TYPE SPECIFICATION CHART)

Determine CAN system type based on vehicle equipment.

NOTE:

- This chart is used if CONSULT does not automatically recognize CAN system type.
- There are two styles for CAN system type specification charts. Depending on the number of available system types, either style A or style B may be used.

CAN System Type Specification Chart (Style A)

NOTE:

A
B
C
D
E
F
G
H
I
J
K
L

LAN

DIAGNOSIS AND REPAIR WORKFLOW

< BASIC INSPECTION >

[CAN FUNDAMENTAL]

CAN system type is easily checked with the vehicle equipment identification information shown in the chart.

Example:
Vehicle is equipped as follows: Wagon, AWD, VQ35DE, CVT, VDC, and Intelligent Key system. (○ shows an example of CAN system type.)

CAN System Specification Chart
Determine CAN system type from the following specification chart.

Body type	Wagon					
Axle	2WD			AWD		
Engine	QR25DE		VQ35DE			
Transmission	A/T			CVT		
Brake control	ABS				VDC	
Intelligent Key system		×		×		×
CAN system type	1	2	3	4	5	6
CAN communication control unit						
ECM	×	×	×	×	×	×
AWD control unit					×	×
Air bag diagnosis sensor unit	×	×	×	×	×	×
BCM	×	×	×	×	×	×
Intelligent Key unit		×		×		×
Steering angle sensor					×	×
EPS control unit	×	×	×	×	×	×
Combination meter	×	×	×	×	×	×
ABS actuator and electric unit (control unit)	×	×	×	×	×	×
TCM	×	×	×	×	×	×
IPDM E/R	×	×	×	×	×	×

× : Applicable

VEHICLE EQUIPMENT IDENTIFICATION INFORMATION
NOTE:
Check CAN system type from the vehicle shape and equipment.

(A)

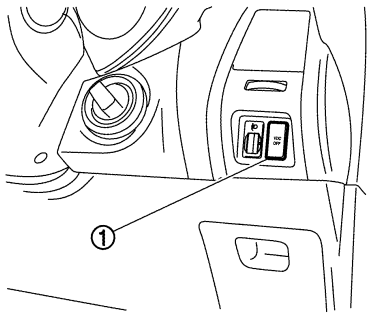

1. VDC OFF switch
A. With VDC

(B)

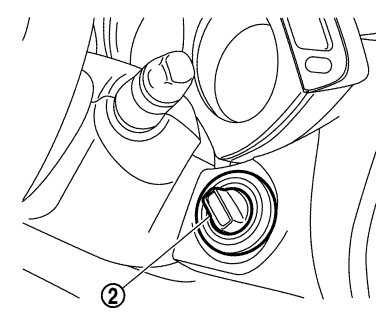

2. Ignition knob
B. With Intelligent Key system

For the above case, CAN system type is "6".

JSMIA0529GB

CAN System Type Specification Chart (Style B)

NOTE:

DIAGNOSIS AND REPAIR WORKFLOW

< BASIC INSPECTION >

[CAN FUNDAMENTAL]

CAN system type is easily checked with the vehicle equipment identification information shown in the chart.

Example:
Vehicle is equipped as follows: Sedan, 2WD, MR20DE, CVT, ABS, Active AFS, Intelligent Key system, Navigation system and Automatic drive positioner. (○ shows an example of CAN system type.)

CAN System Specification Chart
Refer to the specification as shown in the chart.

Body type	Sedan		
Axle	2WD		AWD
Engine	HR15DE	MR20DE	HR15DE
Transmission	A/T	CVT	A/T
Brake control		ABS	
Specification chart	XX.XX. SPECIFICATION CHART A.	XX.XX. SPECIFICATION CHART B.	XX.XX. SPECIFICATION CHART C.

×: Applicable

Check the vehicle equipment with the vehicle identification number plate.
Check the vehicle equipment.
Select the applicable vehicle equipment. Refer to the specification chart.

SPECIFICATION CHART B
Determine CAN system type from the following specification chart.

Body type	Sedan													
Axle	2WD													
Engine	MR20DE													
Transmission	CVT													
Brake control	ABS													
Active AFS		×			×	×			×	×		×	×	×
Intelligent Key system			×		×		×	×	×	×	×	×	×	×
Navigation system				×		×		×		×		×		×
Automatic drive positioner									×		×		×	×
CAN system type	9	10	11	12	13	14	15	16	17	18	19	20		
CAN communication control unit														
ECM	×	×	×	×	×	×	×	×	×	×	×	×	×	×
AFS control unit		×			×	×				×	×		×	
BCM	×	×	×	×	×	×	×	×	×	×	×	×	×	×
IPDM E/R	×	×	×	×	×	×	×	×	×	×	×	×	×	×

×: Applicable

Check the vehicle equipment.
The number indicates the CAN system type of the vehicle.

VEHICLE EQUIPMENT IDENTIFICATION INFORMATION
NOTE:
Check CAN system type from the vehicle shape and equipment.

In the above example,

- Checking Xenon bulb and bending lamp lead to judge whether or not Active AFS is equipped.
- Checking the ignition knob leads to judge whether or not Intelligent Key system is equipped.
- Checking display and multifunction switch lead to judge whether or not Navigation system is equipped.
- Checking seat memory switch leads to judge whether or not Automatic drive positioner is equipped.

1. Bending lamp 2. Xenon bulb 3. Ignition knob
4. Display 5. Multifunction switch 6. Seat memory switch
A. With active AFS B. With Intelligent Key system C. With navigation system
D. With automatic drive positioner

For the above case, CAN system type is "20".

JSMIA0530GB

CREATE INTERVIEW SHEET

Fill out the symptom described by the customer, vehicle condition, and CAN system type on the interview sheet.

DIAGNOSIS AND REPAIR WORKFLOW

< BASIC INSPECTION >

[CAN FUNDAMENTAL]

Interview Sheet (Example)

CAN Communication System Diagnosis Interview Sheet	
Date received:	3, Feb. 2006
Type: DBA-KG11	VIN No.: KG11-005040
Model: BDRARGZG11EDA-E-J-	
First registration: 10, Jan. 2001	Mileage: 62,140
CAN system type: Type 19	
Symptom (Results from interview with customer)	
<ul style="list-style-type: none">· Headlamps suddenly turn ON while driving the vehicle.· The engine does not restart after stopping the vehicle and turning the ignition switch OFF.· The cooling fan continues rotating while turning the ignition switch ON.	
Condition at inspection	
Error Symptom: <u>Present</u> / Past	
The engine does not start. While turning the ignition switch ON, <ul style="list-style-type: none">· The headlamps (Lo) turn ON, and the cooling fan continues rotating.· The interior lamp does not turn ON.	

JSMIA0531GB

DETECT THE ROOT CAUSE

CAN diagnosis function of CONSULT detects the root cause.

HOW TO USE THIS SECTION

< HOW TO USE THIS MANUAL >

[CAN]

HOW TO USE THIS MANUAL

HOW TO USE THIS SECTION

Information

INFOID:000000008510082

- “CAN” of LAN Section describes information peculiar to a vehicle and inspection procedures.
- For trouble diagnosis procedure, refer to [LAN-20. "Trouble Diagnosis Flow Chart"](#) of “CAN FUNDAMENTAL”.

Abbreviation List

INFOID:000000008510083

Unit name abbreviations in CONSULT CAN diagnosis and in this section are as per the following list.

Abbreviation	Unit name
4WD	4WD control unit
A-BAG	Air bag diagnosis sensor unit
ABS	ABS actuator and electric unit (control unit)
ADP	Driver seat control unit
AV	AV control unit
AVM	Around view monitor control unit
BCM	BCM
CGW	CAN gateway
DLC	Data link connector
ECM	ECM
EPS	Power steering control module
HVAC	A/C auto amp.
IPDM-E	IPDM E/R
M&A	Combination meter
PWBD	Automatic back door control module
STRG	Steering angle sensor
SONAR	Sonar control unit
TCM	TCM

A
B
C
D
E
F
G
H
I
J
K
L

LAN

N
O
P

PRECAUTION

PRECAUTIONS

Precaution for Supplemental Restraint System (SRS) "AIR BAG" and "SEAT BELT PRE-TENSIONER"

INFOID:000000009002456

The Supplemental Restraint System such as "AIR BAG" and "SEAT BELT PRE-TENSIONER", used along with a front seat belt, helps to reduce the risk or severity of injury to the driver and front passenger for certain types of collision. This system includes seat belt switch inputs and dual stage front air bag modules. The SRS system uses the seat belt switches to determine the front air bag deployment, and may only deploy one front air bag, depending on the severity of a collision and whether the front occupants are belted or unbelted. Information necessary to service the system safely is included in the SR and SB section of this Service Manual.

WARNING:

- To avoid rendering the SRS inoperative, which could increase the risk of personal injury or death in the event of a collision which would result in air bag inflation, all maintenance must be performed by an authorized NISSAN/INFINITI dealer.
- Improper maintenance, including incorrect removal and installation of the SRS, can lead to personal injury caused by unintentional activation of the system. For removal of Spiral Cable and Air Bag Module, see the SR section.
- Do not use electrical test equipment on any circuit related to the SRS unless instructed to in this Service Manual. SRS wiring harnesses can be identified by yellow and/or orange harnesses or harness connectors.

PRECAUTIONS WHEN USING POWER TOOLS (AIR OR ELECTRIC) AND HAMMERS

WARNING:

- When working near the Airbag Diagnosis Sensor Unit or other Airbag System sensors with the Ignition ON or engine running, DO NOT use air or electric power tools or strike near the sensor(s) with a hammer. Heavy vibration could activate the sensor(s) and deploy the air bag(s), possibly causing serious injury.
- When using air or electric power tools or hammers, always switch the Ignition OFF, disconnect the battery and wait at least 3 minutes before performing any service.

Precautions for Trouble Diagnosis

INFOID:000000008510085

CAUTION:

Follow the instructions listed below. Failure to do this may cause damage to parts:

- Never apply 7.0 V or more to the measurement terminal.
- Use a tester with open terminal voltage of 7.0 V or less.
- Turn the ignition switch OFF and disconnect the battery cable from the negative terminal when checking the harness.

Precautions for Harness Repair

INFOID:000000008510086

- Solder the repaired area and wrap tape around the soldered area.

NOTE:

A fray of twisted lines must be within 110 mm (4.33 in).

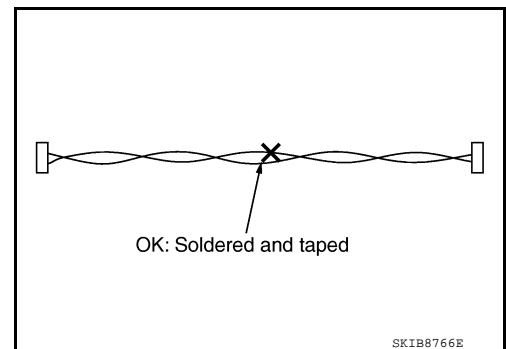

PRECAUTIONS

< PRECAUTION >

[CAN]

- Bypass connection is never allowed at the repaired area.

NOTE:

Bypass connection may cause CAN communication error. The spliced wire becomes separated and the characteristics of twisted line are lost.

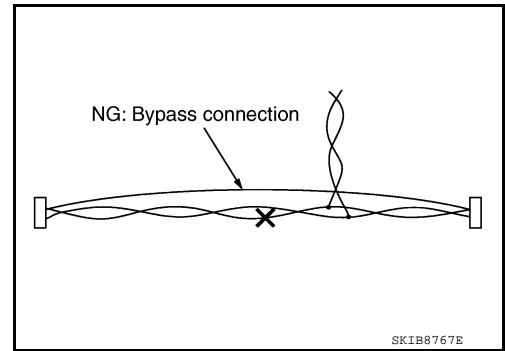

- Replace the applicable harness as an assembly if error is detected on the shield lines of CAN communication line.

A
B
C
D
E
F
G
H
I
J
K
L

LAN

N
O
P

SYSTEM DESCRIPTION

COMPONENT PARTS

Component Parts Location

INFOID:000000008510087

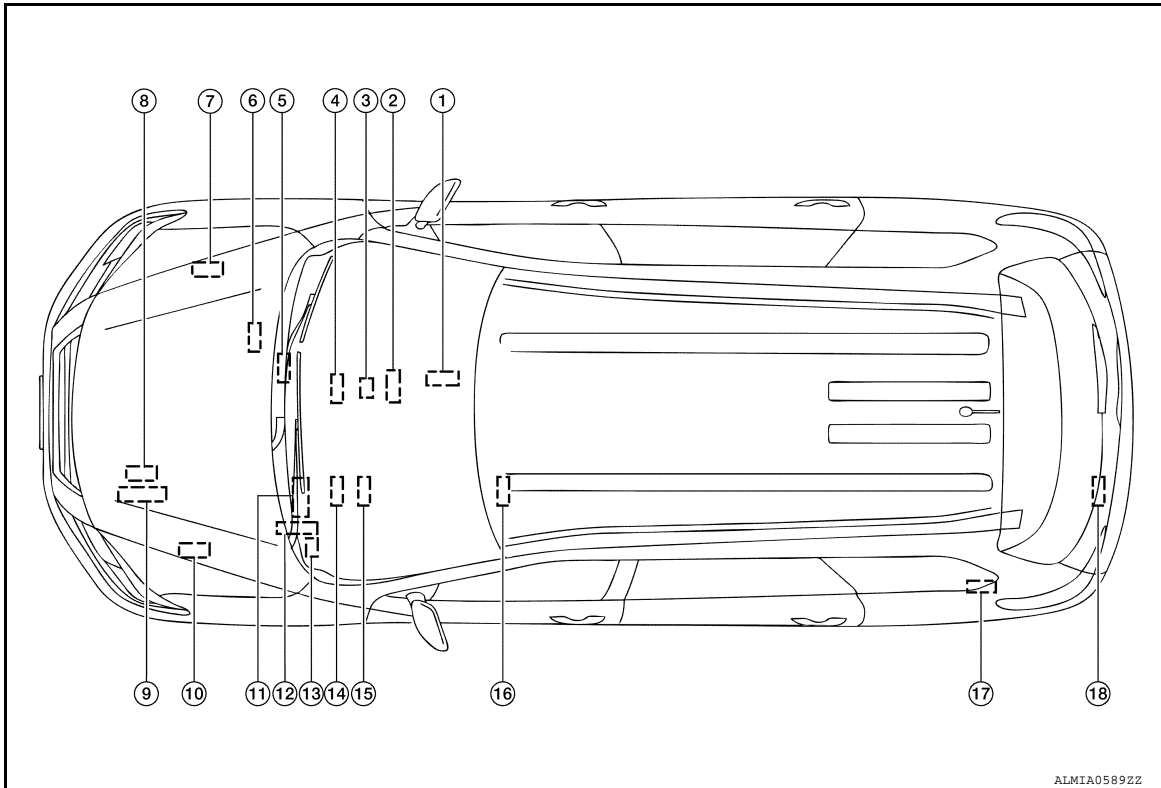

ALMIA05892Z

- | | | |
|------------------------------------|--------------------------------------|---|
| ① Around view monitor control unit | ② AV control unit | ③ A/C auto amp. |
| ④ Air bag diagnosis sensor unit | ⑤ CAN gateway | ⑥ ABS actuator and electric unit (control unit) |
| ⑦ Power steering control module | ⑧ TCM | ⑨ ECM |
| ⑩ IPDM E/R | ⑪ BCM | ⑫ Sonar control unit |
| ⑬ Data link connector | ⑭ Combination meter | ⑮ Steering angle sensor |
| ⑯ Driver seat control unit | ⑰ Automatic back door control module | ⑱ 4WD control unit |

SYSTEM

< SYSTEM DESCRIPTION >

[CAN]

SYSTEM

CAN COMMUNICATION SYSTEM

CAN COMMUNICATION SYSTEM : System Description

INFOID:000000008510088

SYSTEM DIAGRAM

Without Around View Monitor

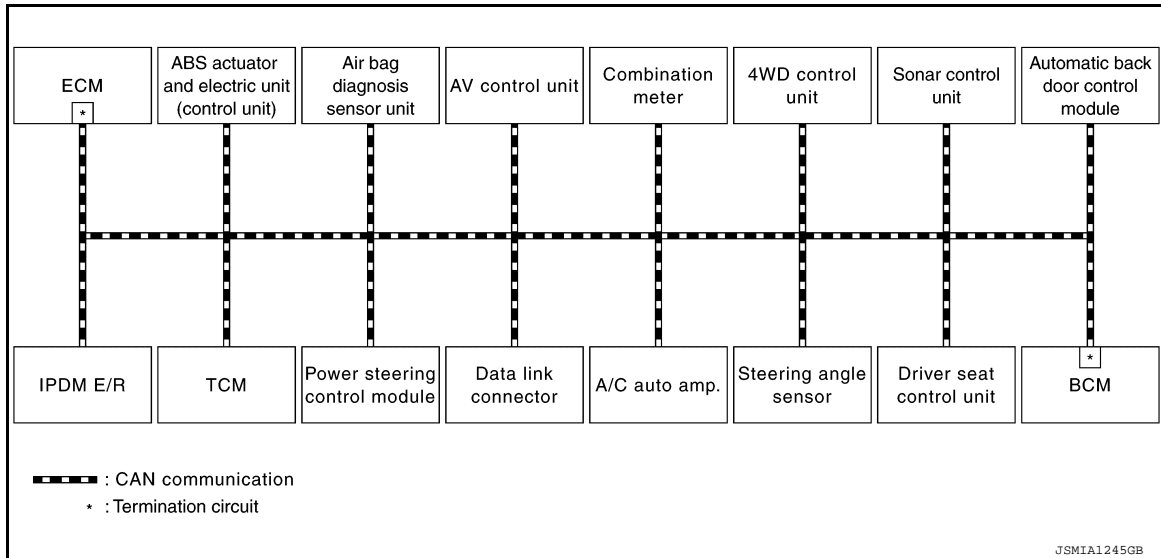

A
B
C
D
E
F
G
H
I
J
K
L

LAN

< SYSTEM DESCRIPTION >

With Around View Monitor

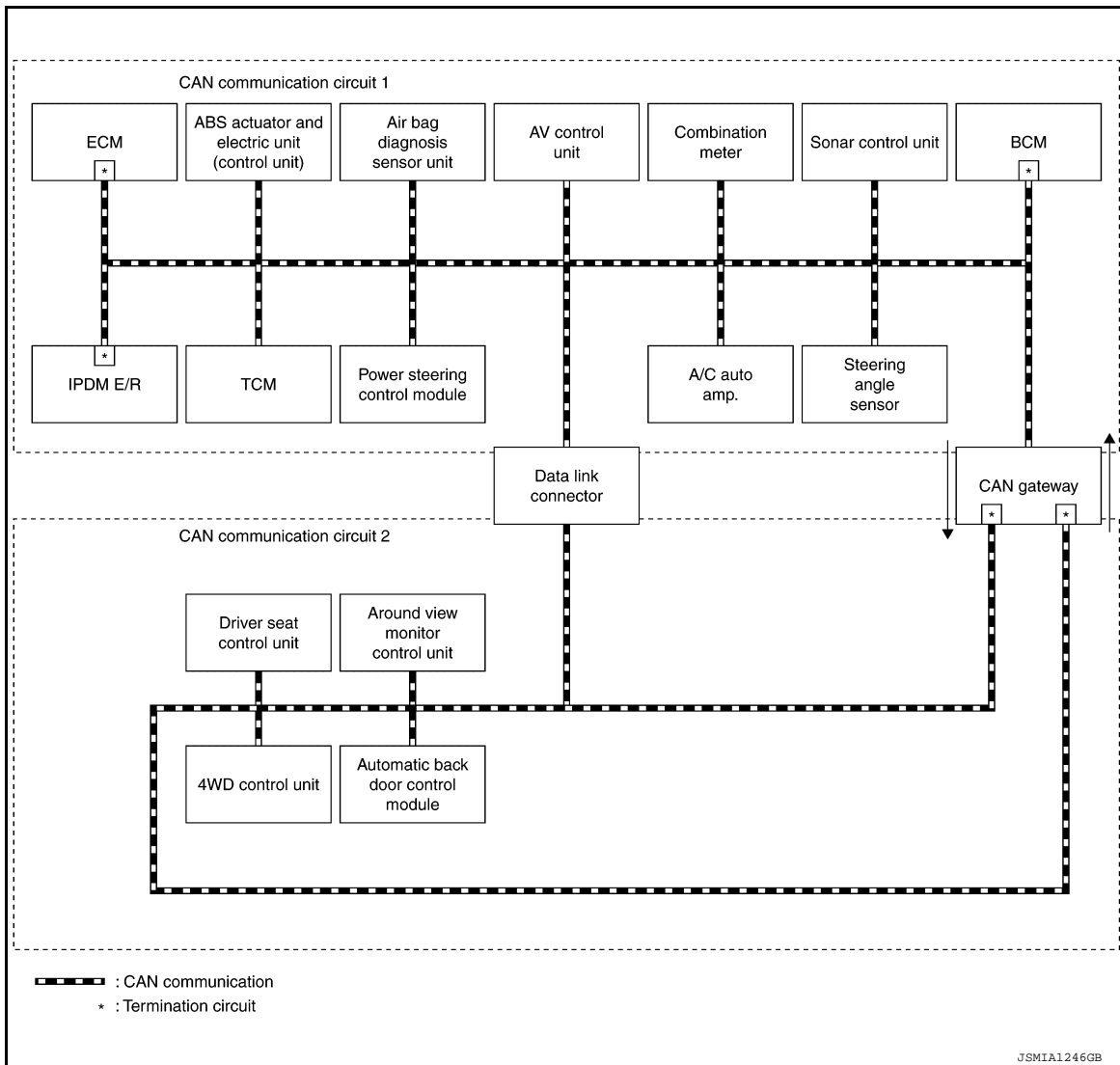

DESCRIPTION

- CAN (Controller Area Network) is a serial communication line for real time application. It is an on-vehicle multiplex communication line with high data communication speed and excellent error detection ability. Many electronic control units are equipped onto a vehicle, and each control unit shares information and links with other control units during operation (not independent). In CAN communication, control units are connected with 2 communication lines (CAN-H line, CAN-L line) allowing a high rate of information transmission with less wiring. Each control unit transmits/receives data but selectively reads required data only.
- The CAN gateway include a gateway function and communicate signals between the CAN communication circuit 1 and the CAN communication circuit 2. Refer to [LAN-96. "System Description"](#).

CAN Communication Signal Generation

SYSTEM

[CAN]

< SYSTEM DESCRIPTION >

- Termination circuits (resistors) are connected across the CAN communication system. When transmitting a CAN communication signal, each control unit passes a current to the CAN-H line and the current returns to the CAN-L line.

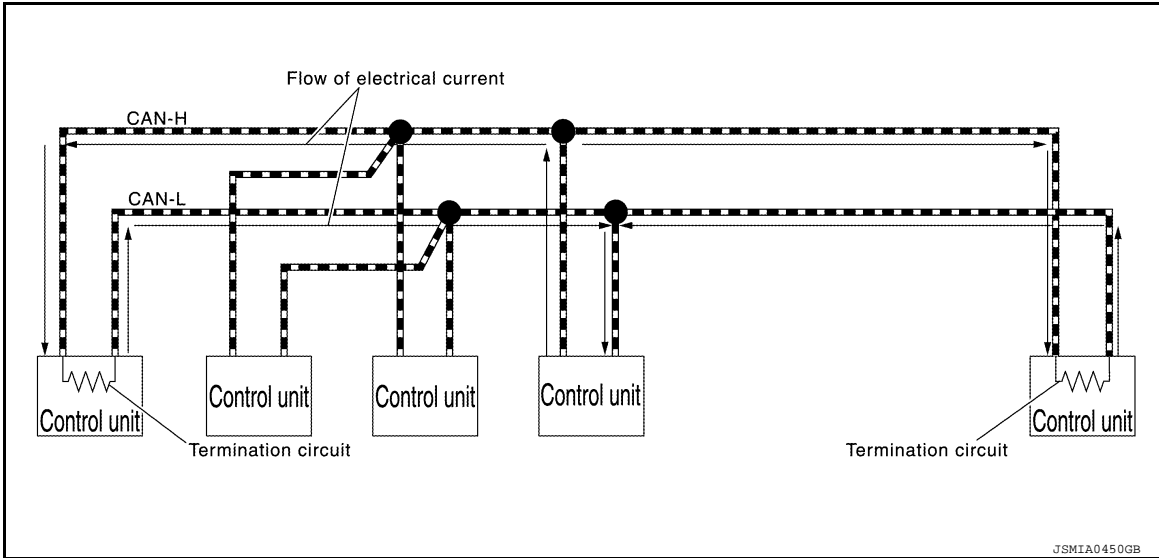

- The current flows separately into the termination circuits connected across the CAN communication system and the termination circuits drop voltage to generate a potential difference between the CAN-H line and the CAN-L line.

NOTE:

A signal with no current passage is called "Recessive" and one with current passage is called "Dominant".

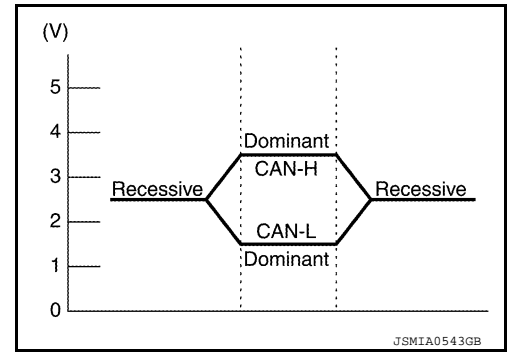

- The system produces digital signals for signal communications, by using the potential difference.

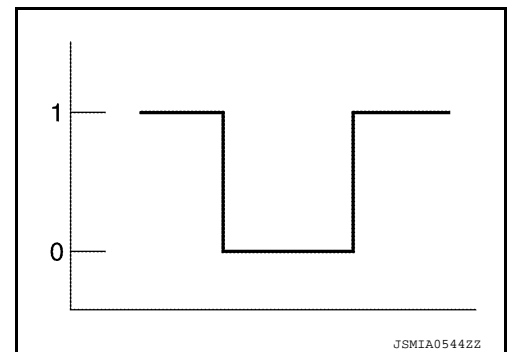

The Construction of CAN Communication Signal (Message)

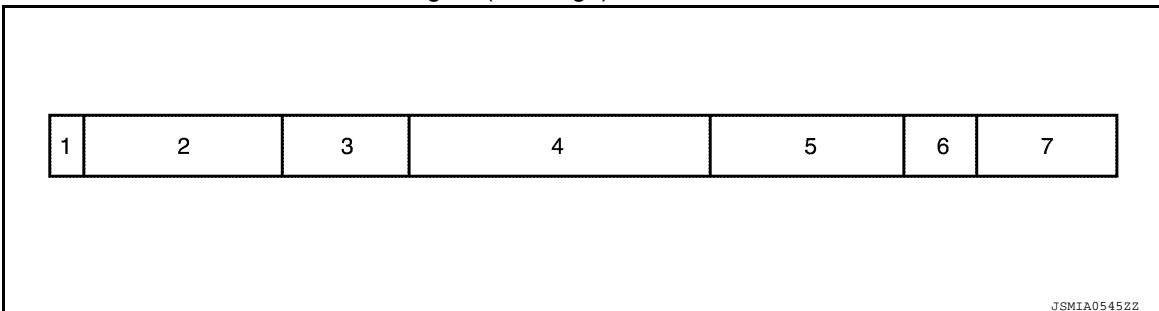

A
B
C
D
E
F
G
H
I
J
K
L
N
O
P

LAN

No.	Message name	Description
1	Start of frame (1 bit)	Start of message.
2	Arbitration of field (11 bit)	Priorities of message-sending are shown when there is a possibility that multiple messages are sent at the same time.
3	Control field (6 bit)	Signal quantity in data field is shown.
4	Data field (0-64 bit)	Actual signal is shown.
5	CRC field (16 bit)	<ul style="list-style-type: none"> The transmitting control unit calculates sending data in advance and writes the calculated value in a message. The receiving control unit calculates received data and judges that the data reception is normal when the calculated value is the same as the value written in the sent data.
6	ACK field (2 bit)	The completion of normal reception is sent to the transmitting control unit.
7	End of frame (7 bit)	End of message.

CAN COMMUNICATION LINE

The CAN communication line is a twisted pair wire consisting of strands of CAN-H (1) and CAN-L (2) and has noise immunity.

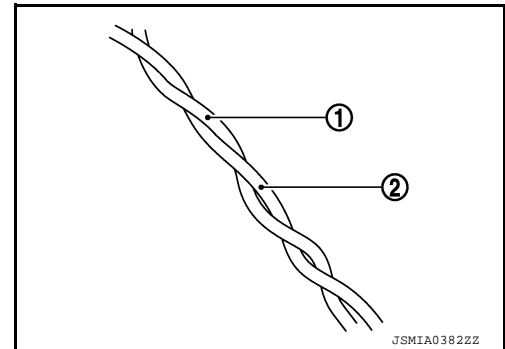

NOTE:

The CAN communication system has the characteristics of noise-resistant because this system produces digital signals by using the potential difference between the CAN-H line and the CAN-L line and has the twisted pair wire structure.

Since the CAN-H line and the CAN-L line are always adjacent to each other, the same degree of noise occurs, respectively, when a noise (1) occurs. Although the noise changes the voltage, the potential difference (2) between the CAN-H line and the CAN-L line is insensitive to noise. Therefore, noise-resistant signals can be obtained.

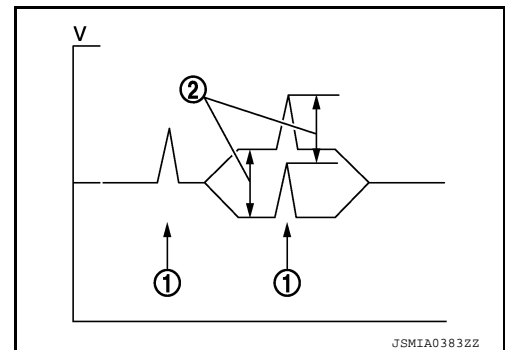

CAN SIGNAL COMMUNICATIONS

Each control unit of the CAN communication system transmits signals through the CAN communication control circuit included in the control unit and receives only necessary signals from each control unit to perform various kinds of control.

SYSTEM

[CAN]

< SYSTEM DESCRIPTION >

• Example: Transmitted signals

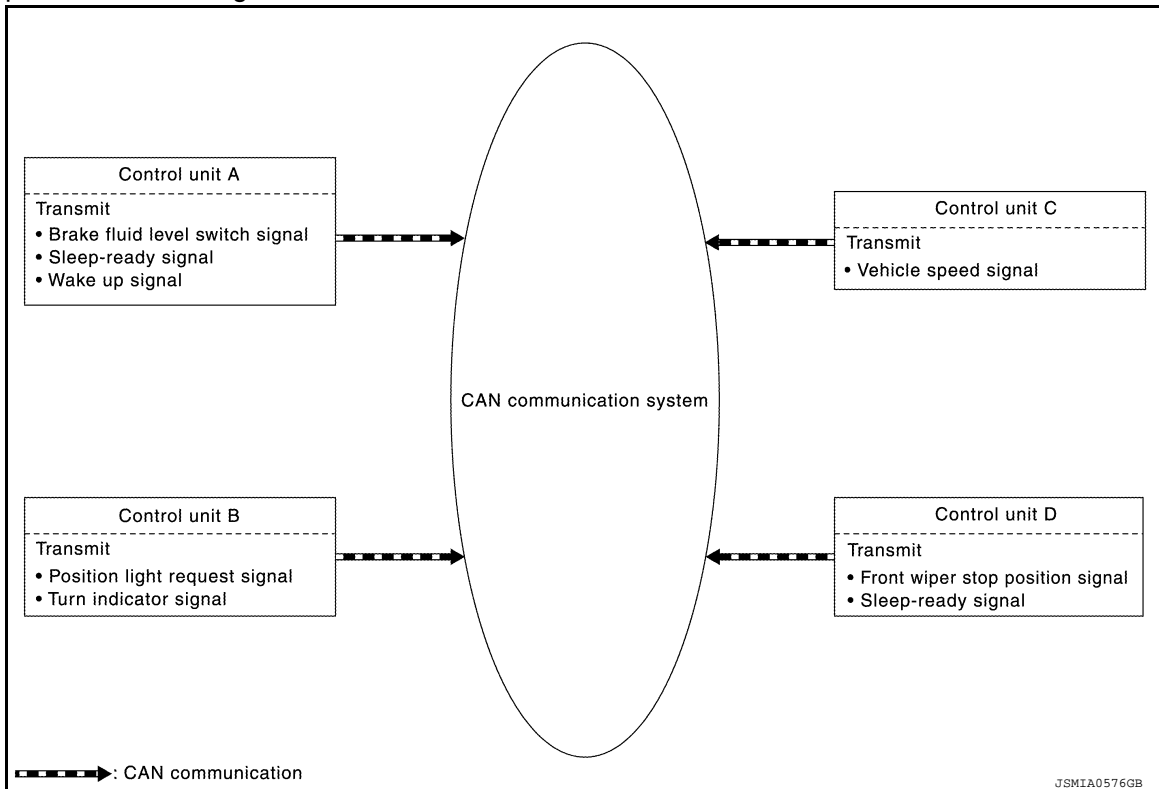

• Example: Received signals

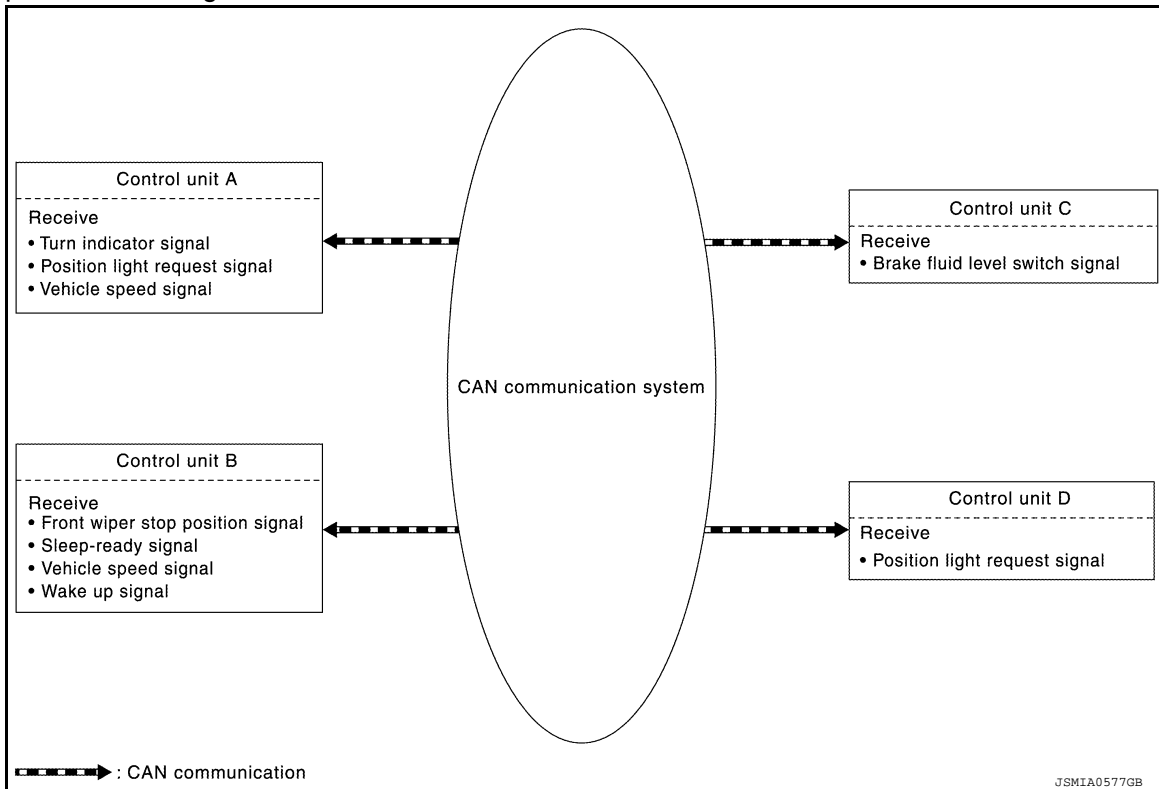

NOTE:

The above signal names and signal communications are provided for reference purposes. For CAN communications signals of this vehicle, refer to [LAN-36. "CAN COMMUNICATION SYSTEM : CAN Communication Signal Chart"](#).

A
B
C
D
E
F
G
H
I
J
K
L
N
O
P

LAN

SYSTEM

< SYSTEM DESCRIPTION >

[CAN]

CAN COMMUNICATION SYSTEM : CAN Communication Control Circuit

INFOID:000000008510089

CAN communication control circuit is incorporated into the control unit and transmits/receives CAN communication signals.

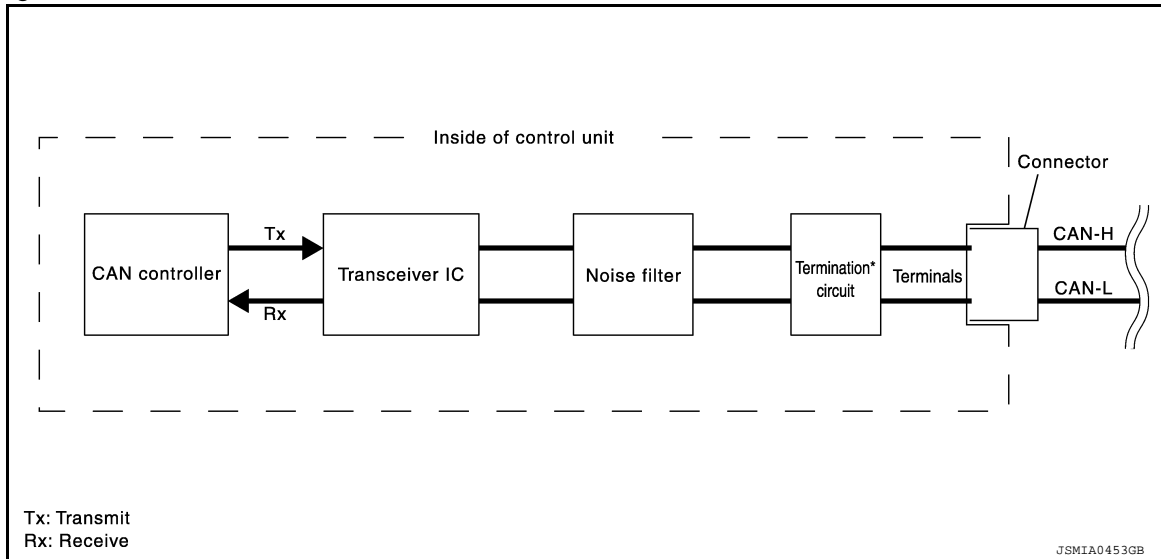

Component	System description
CAN controller	It controls CAN communication signal transmission and reception, error detection, etc.
Transceiver IC	It converts digital signal into CAN communication signal, and CAN communication signal into digital signal.
Noise filter	It eliminates noise of CAN communication signal.
Termination circuit* (Resistance of approx. 120 Ω)	Generates a potential difference between CAN-H and CAN-L.

*: These are the only control units wired with both ends of CAN communication system.

CAN COMMUNICATION SYSTEM : CAN System Specification Chart

INFOID:000000008510090

Determine CAN system type from the following specification chart.

NOTE:

Refer to [LAN-20, "Trouble Diagnosis Procedure"](#) for how to use CAN system specification chart.

Body type	Wagon								
Axle	2WD				4WD				
Engine	VQ35DE								
Transmission	CVT								
Brake control	VDC								
Color display		×	×	×		×	×	×	×
Around view monitor				×					×
Automatic back door system			×	×			×	×	×
Automatic drive positioner			×	×				×	×
CAN system type	1	2	3	4	5	6	7	8	9
CAN communication control unit									
ECM	×	×	×	×	×	×	×	×	×
IPDM E/R	×	×	×	×	×	×	×	×	×
TCM	×	×	×	×	×	×	×	×	×
ABS actuator and electric unit (control unit)	×	×	×	×	×	×	×	×	×

SYSTEM

< SYSTEM DESCRIPTION >

[CAN]

Body type	Wagon								
Axle	2WD				4WD				
Engine	VQ35DE								
Transmission	CVT								
Brake control	VDC								
Color display		×	×	×		×	×	×	×
Around view monitor				×					×
Automatic back door system			×	×			×	×	×
Automatic drive positioner			×	×				×	×
CAN system type	1	2	3	4	5	6	7	8	9
CAN communication control unit									
Power steering control module	×	×	×	×	×	×	×	×	×
Air bag diagnosis sensor unit	×	×	×	×	×	×	×	×	×
AV control unit		×	×	×		×	×	×	×
Data link connector	×	×	×	×	×	×	×	×	×
A/C auto amp.	×	×	×	×	×	×	×	×	×
Combination meter	×	×	×	×	×	×	×	×	×
Sonar control unit		×	×	×		×	×	×	×
Steering angle sensor	×	×	×	×	×	×	×	×	×
CAN gateway				×					×
BCM	×	×	×	×	×	×	×	×	×
Around view monitor control unit				×					×
Driver seat control unit			×	×				×	×
4WD control unit					×	×	×	×	×
Automatic back door control module			×	×			×	×	×

×: Applicable

VEHICLE EQUIPMENT IDENTIFICATION INFORMATION

NOTE:

Check CAN system type from the vehicle shape and equipment.

A
B
C
D
E
F
G
H
I
J
K
L

LAN

N
O
P

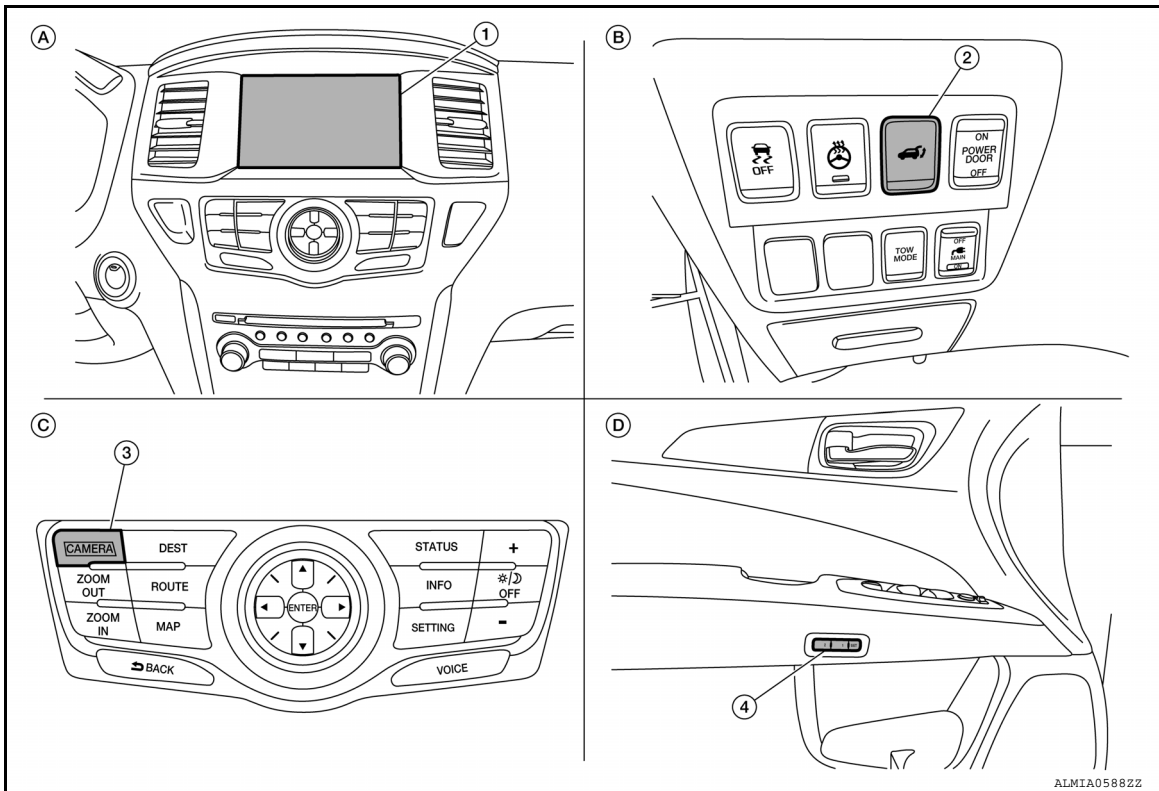

- ① Color display
- ② Automatic back door switch
- ③ Camera switch
- ④ Seat memory switches
- Ⓐ With color display
- Ⓑ With automatic back door system
- Ⓒ With around view monitor
- Ⓓ With automatic drive positioner

CAN COMMUNICATION SYSTEM : CAN Communication Signal Chart

INFOID:000000008510091

Refer to [LAN-19, "How to Use CAN Communication Signal Chart"](#) for how to use CAN communication signal chart.

NOTE:

Refer to [LAN-25, "Abbreviation List"](#) for the abbreviations of the connecting units.

T: Transmit R: Receive

Signal name	ECM	IPDM-E	TCM	ABS	EPS	AV	HVAC	M&A	STRG	SONAR	CGW	BCM	AVM	ADP	4WD	PWBD
A/C compressor request signal	T	R														
Accelerator pedal position signal	T		R	R											R	
ASCD operation signal	T		R													
ASCD status signal	T							R								
Closed throttle position signal	T		R													
Cooling fan speed request signal	T	R														
Engine and CVT integrated control signal	T		R													
	R		T													
Engine coolant temperature signal	T						R	R								
Engine speed signal	T		R	R				R							R	
Engine status signal	T				R	R		R				R				
Fuel consumption monitor signal	T					R		R								

SYSTEM

< SYSTEM DESCRIPTION >

[CAN]

Signal name	ECM	IPDM-E	TCM	ABS	EPS	AV	HVAC	M&A	STRG	SONAR	CGW	BCM	AVM	ADP	4WD	PWBD	
Fuel filler cap warning display signal	T							R									A
Malfunction indicator lamp signal	T							R									B
Oil pressure warning lamp signal	T							R									C
Power generation command value signal	T	R															
A/C compressor feedback signal	R	T				R	R										D
Front wiper position signal		T										R					
High beam status signal	R	T				R											E
Hood switch signal		T										R					
Low beam status signal	R	T				R											
Push-button ignition switch status signal		T										R					F
CVT ratio signal			T												R		
CVT position indicator signal			T			R		R		R		R	R	R		R	G
Current gear position signal	R		T														
Input speed signal	R		T	R											R		
N range signal			T	R								R					H
Next gear position signal	R		T														
OD OFF indicator signal			T					R									
Output shaft revolution signal	R		T														I
P range signal			T									R					
R range signal			T	R													J
Shift position signal	R		T					R		R			R	R			
Shift schedule signal	R		T														
Tow mode indicator signal			T					R									K
ABS malfunction signal			R	T													
ABS operation signal			R	T		R											L
ABS warning lamp signal				T				R									
Brake warning lamp signal				T				R									
Rear LH wheel speed signal				T									R				LAN
Rear RH wheel speed signal				T									R				
Stop lamp switch signal			R									T					N
				T									R		R		
TCS operation signal	R		R	T													
VDC OFF indicator lamp signal				T				R									O
VDC operation signal	R		R	T													
VDC warning lamp signal				T				R									
Vehicle speed signal			R	T				R		R		R	R	R	R	R	P
	R	R			R	R	R	T				R		R		R	
EPS operation signal	R				T												
Hydraulic pump electric power steering warning lamp signal					T			R									
A/C switch operation signal						T	R										

SYSTEM

< SYSTEM DESCRIPTION >

[CAN]

Signal name	ECM	IPDM-E	TCM	ABS	EPS	AV	HVAC	M&A	STRG	SONAR	CGW	BCM	AVM	ADP	4WD	PWBD
Rear window defogger switch signal						T						R				
System setting signal						T						R				
						R						T				
Voice recognition signal						T	R									
A/C display signal						R	T									
A/C evaporator temperature signal	R						T									
A/C ON signal	R						T									
Ambient sensor signal							T	R								
Blower fan ON signal	R						T									
Target A/C evaporator temperature signal	R						T									
Brake fluid level switch signal				R				T								
Distance to empty signal						R		T								
Fuel filler cap warning reset signal	R							T								
Fuel level low warning signal						R		T								
Fuel level sensor signal	R							T								
Odometer signal								T				R				
Overdrive control switch signal			R					T								
Parking brake switch signal				R				T				R			R	R
Seat belt buckle switch signal (driver side)								T				R				
Sleep-ready signal								T				R				
		T										R				
Tow mode switch signal			R									R				T
												R				
Wake up signal												R				
												R				T
Buzzer request signal								R				T				
										R			T			
Low tire pressure warning lamp signal								R				T				
Steering angle sensor malfunction signal				R	R				T				R			
Steering angle sensor signal				R	R	R			T				R		R	
Steering angle speed signal				R					T							
Steering calibration signal				R					T				R			
Sonar status signal										T			R			
Automatic back door request signal												T				R
Back door lock status signal												T				R
Buzzer output signal								R				T				
Day time running light request signal		R					R					T	R			
Dimmer signal								R				T				
Door switch signal		R					R	R				T	R	R		

SYSTEM

< SYSTEM DESCRIPTION >

[CAN]

Signal name	ECM	IPDM-E	TCM	ABS	EPS	AV	HVAC	M&A	STRG	SONAR	CGW	BCM	AVM	ADP	4WD	PWBD	A
Door unlock signal												T		R			B
Front fog light request signal		R					R	R				T	R				C
Front wiper request signal		R				R	R					T					D
Handle position signal												T		R			E
High beam request signal		R					R	R				T	R				F
Horn reminder signal		R										T					G
Ignition switch ON signal		R										T					H
		T										R					I
Ignition switch signal		R										T		R			J
Intelligent Key system warning display signal								R				T					K
Interlock/PNP switch signal		R										T					L
		T										R					LAN
Key ID signal							R					T		R			N
Low beam request signal		R					R					T	R				O
Meter display signal								R				T					P
Meter ring illumination request signal								R				T					
Oil pressure switch signal								R				T					
		T						R				R					
Position light request signal		R					R	R				T	R				
Rear window defogger control signal		R					R					T					
	R	T				R											
Sleep wake up signal		R						R			R	T		R		R	
Starter control relay signal		R										T					
Starter relay status signal		R						R				T					
		T										R					
Starting mode signal												T		R		R	
Theft warning horn request signal		R										T					
Trunk switch signal								R				T	R				
Turn indicator signal						R	R	R				T	R				
Sonar setting change signal										R			T				
4WD signal				R											T		
4WD warning icon/display signal								R							T		
Hazard request signal								R									T

NOTE:

CAN data of the air bag diagnosis sensor unit is not used by usual service work, thus it is omitted.

CAN SYSTEM (WITHOUT AROUND VIEW MONITOR SYSTEM)

[CAN]

< WIRING DIAGRAM >

WIRING DIAGRAM

CAN SYSTEM (WITHOUT AROUND VIEW MONITOR SYSTEM)

Wiring Diagram

INFOID:000000008510093

CAN SYSTEM - WITHOUT AROUND VIEW MONITOR SYSTEM

- ◊BN◊ : WITH BOSE AUDIO SYSTEM-WITHOUT NAVI
- ◊NN◊ : WITH NAVIGATION SYSTEM AND BOSE AUDIO SYSTEM
- ◊NP◊ : WITH NAVIGATION SYSTEM WITHOUT BOSE AUDIO SYSTEM
- ◊SV◊ : WITH SONAR SYSTEM
- ◊BN◊ : 11 ◊BN◊ : 12
- *1 ◊NN◊ : 78 *2 ◊NN◊ : 62
- ◊NP◊ : 11 ◊NP◊ : 12

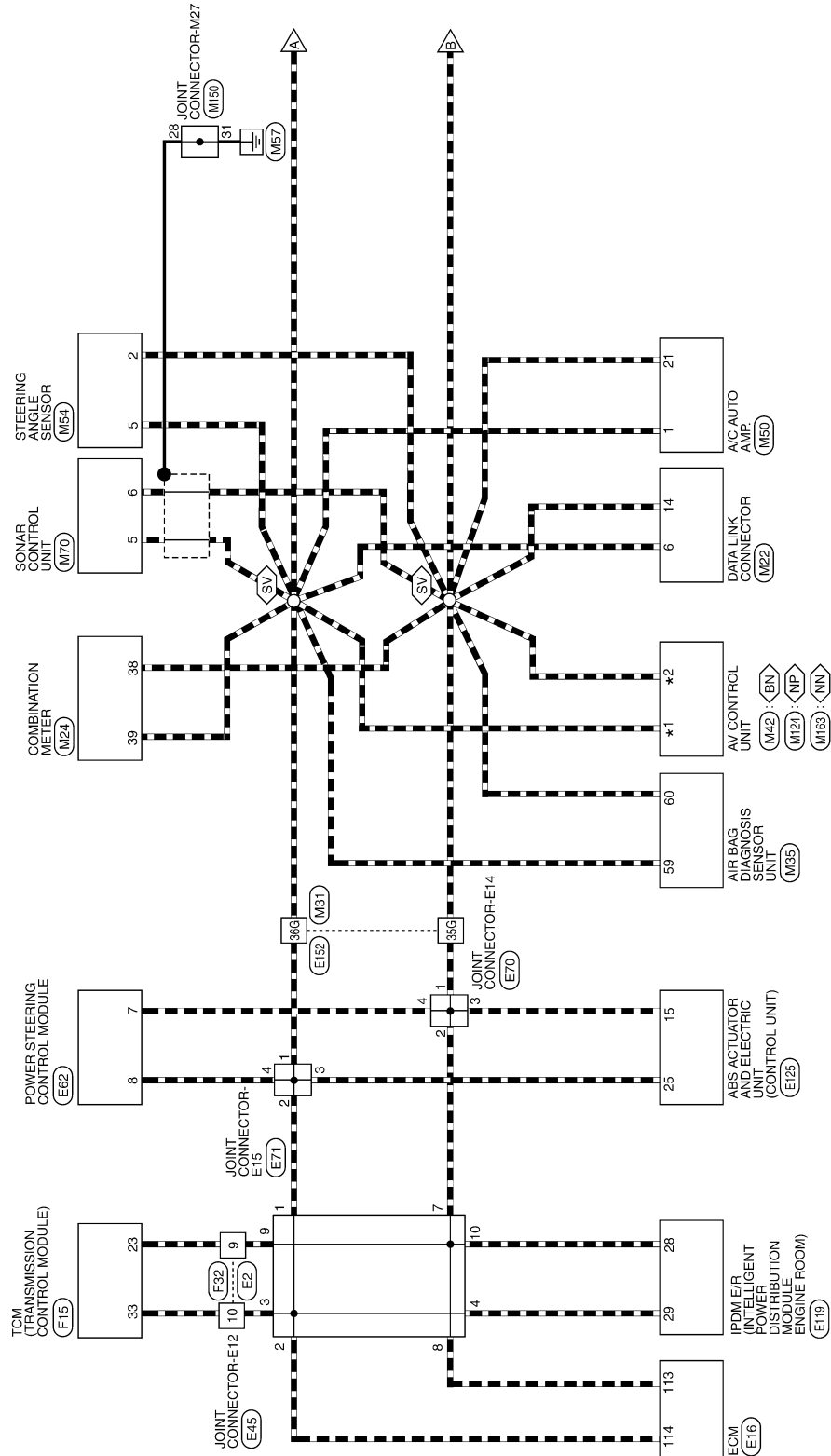

RAMWA0649GB

CAN SYSTEM (WITHOUT AROUND VIEW MONITOR SYSTEM)

< WIRING DIAGRAM >

[CAN]

<AD> : WITH AUTOMATIC DRIVE POSITIONER
 <PB> : WITH POWER BACK DOOR
 <4W> : WITH 4-WHEEL DRIVE

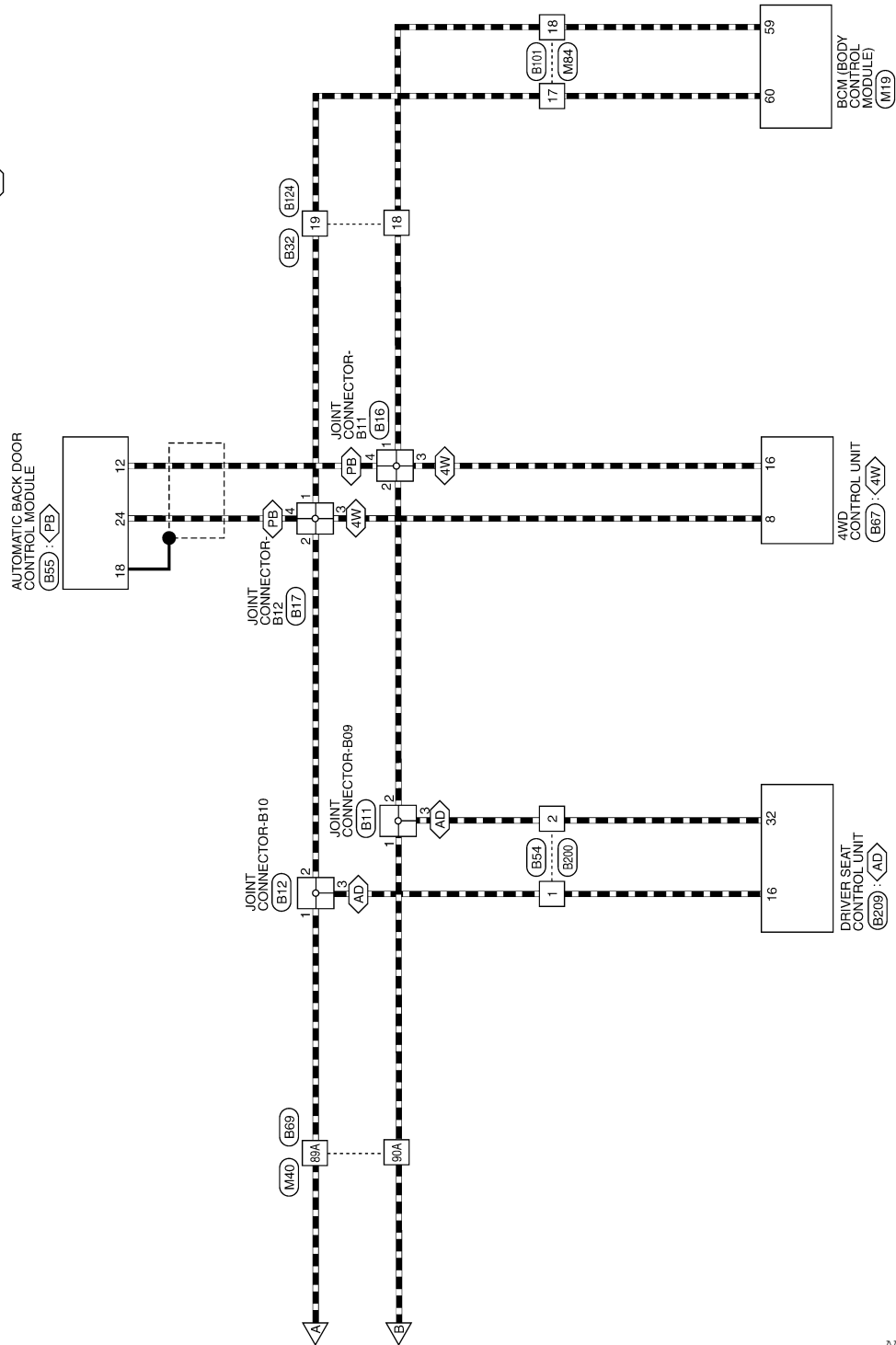

AAMWA0650GB

A
B
C
D
E
F
G
H
I
J
K
L
N
O
P

LAN

CAN SYSTEM (WITHOUT AROUND VIEW MONITOR SYSTEM)

[CAN]

< WIRING DIAGRAM >

CAN SYSTEM CONNECTORS - WITHOUT AROUND VIEW MONITOR

Connector No.	M19
Connector Name	BCM (BODY CONTROL MODULE)
Connector Color	BLACK

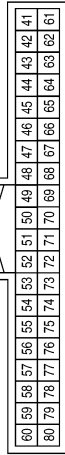

Terminal No.	Color of Wire	Signal Name
59	P	CAN-L
60	L	CAN-H

Connector No.	M22
Connector Name	DATA LINK CONNECTOR
Connector Color	WHITE

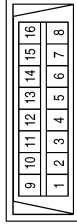

Terminal No.	Color of Wire	Signal Name
6	L	-
14	P	-

Connector No.	M24
Connector Name	COMBINATION METER
Connector Color	WHITE

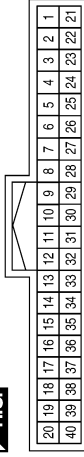

Terminal No.	Color of Wire	Signal Name
38	P	CAN-L
39	L	CAN-H

Connector No.	M31
Connector Name	WIRE TO WIRE
Connector Color	WHITE

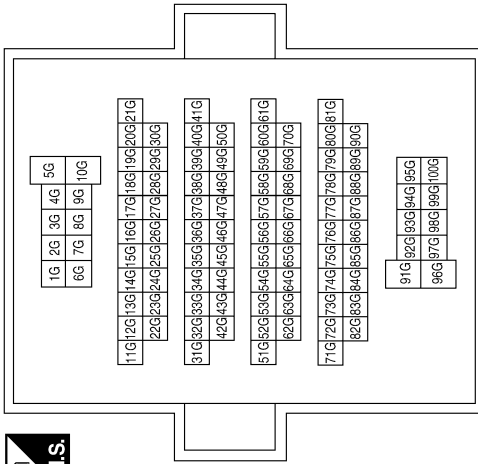

Terminal No.	Color of Wire	Signal Name
35G	P	-
36G	L	-

Connector No.	M35
Connector Name	AIR BAG DIAGNOSIS SENSOR UNIT
Connector Color	YELLOW

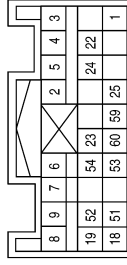

Terminal No.	Color of Wire	Signal Name
59	L	CAN-H
60	P	CAN-L

AAM1A1296GB

CAN SYSTEM (WITHOUT AROUND VIEW MONITOR SYSTEM)

< WIRING DIAGRAM >

[CAN]

Connector No.	M42
Connector Name	AV CONTROL UNIT (WITHOUT NAVIGATION SYSTEM WITH BOSE AUDIO SYSTEM)
Connector Color	WHITE



16	15	14	13	12	11	10	9	8	7	6	5	4	3	2	1
32	31	30	29	28	27	26	25	24	23	22	21	20	19	18	17

Terminal No.	Color of Wire	Signal Name
11	L	CAN-H
12	P	CAN-L

Terminal No.	Color of Wire	Signal Name
89A	L	-
90A	P	-

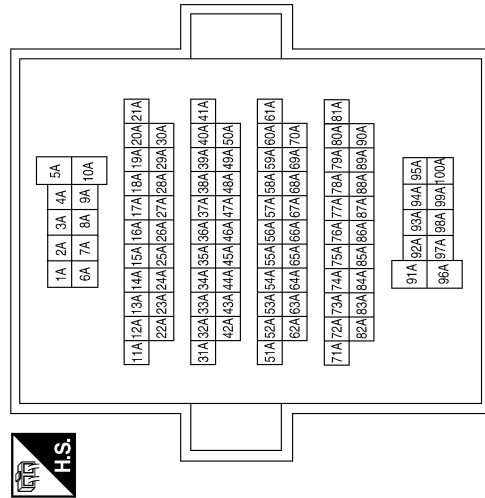

Connector No.	M40
Connector Name	WIRE TO WIRE
Connector Color	BROWN

Connector No.	M70
Connector Name	SONAR CONTROL UNIT
Connector Color	WHITE



12	11	10	9	8	7	6	5	4	3	2	1
24	23	22	21	20	19	18	17	16	15	14	13

Terminal No.	Color of Wire	Signal Name
5	B	CAN-H
6	W	CAN-L

Connector No.	M54
Connector Name	STEERING ANGLE SENSOR
Connector Color	WHITE



1	2	3	4
5	6	7	8

Terminal No.	Color of Wire	Signal Name
2	P	CAN-L
5	L	CAN-H

Connector No.	M50
Connector Name	A/C AUTO AMP.
Connector Color	WHITE



1	2	3	4	5	6	7	8	9	10	11	12	13	14	15	16	17	18	19	20
21	22	23	24	25	26	27	28	29	30	31	32	33	34	35	36	37	38	39	40

Terminal No.	Color of Wire	Signal Name
1	L	CAN-H
21	P	CAN-L

AAMIA1297GB

A
B
C
D
E
F
G
H
I
J
K
L
M
N
O
P

LAN

CAN SYSTEM (WITHOUT AROUND VIEW VIEW MONITOR SYSTEM)

< WIRING DIAGRAM >

[CAN]

Connector No.	M84
Connector Name	WIRE TO WIRE
Connector Color	WHITE

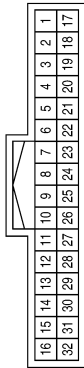

Terminal No.	Color of Wire	Signal Name
17	L	-
18	P	-

Connector No.	M124
Connector Name	AV CONTROL UNIT (WITH NAVIGATION SYSTEM WITHOUT BOSE AUDIO SYSTEM)
Connector Color	WHITE

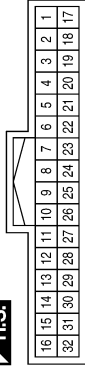

Terminal No.	Color of Wire	Signal Name
11	L	CAN-H
12	P	CAN-L

Connector No.	M150
Connector Name	JOINT CONNECTOR-M27
Connector Color	WHITE

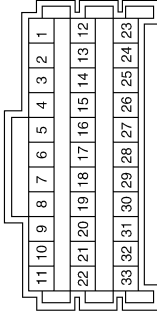

Terminal No.	Color of Wire	Signal Name
28	SHIELD	-
31	GR	-

Connector No.	M163
Connector Name	AV CONTROL UNIT (WITH NAVIGATION SYSTEM AND BOSE AUDIO SYSTEM)
Connector Color	WHITE



Terminal No.	Color of Wire	Signal Name
62	P	CAN-L
78	L	CAN-H

Connector No.	E2
Connector Name	WIRE TO WIRE
Connector Color	WHITE

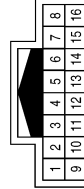

Terminal No.	Color of Wire	Signal Name
9	P	-
10	L	-

Connector No.	E16
Connector Name	ECM
Connector Color	GRAY

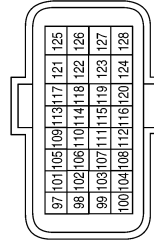

Terminal No.	Color of Wire	Signal Name
113	P	CAN-L
114	L	CAN-H

AAM1A1298GB

CAN SYSTEM (WITHOUT AROUND VIEW MONITOR SYSTEM)

< WIRING DIAGRAM >

[CAN]

Connector No.	E45
Connector Name	JOINT CONNECTOR-E12
Connector Color	BLUE

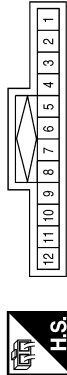

Terminal No.	Color of Wire	Signal Name
1	L	-
2	L	-
3	L	-
4	L	-
7	P	-
8	P	-
9	P	-
10	P	-

Connector No.	E62
Connector Name	POWER STEERING CONTROL MODULE
Connector Color	BLACK



Terminal No.	Color of Wire	Signal Name
7	P	CAN-L
8	L	CAN-H

Connector No.	E70
Connector Name	JOINT CONNECTOR-E14
Connector Color	BLACK



Terminal No.	Color of Wire	Signal Name
1	P	-
2	P	-
3	P	-
4	P	-

Connector No.	E71
Connector Name	JOINT CONNECTOR-E15
Connector Color	BLACK



Terminal No.	Color of Wire	Signal Name
1	L	-
2	L	-
3	L	-
4	L	-

Connector No.	E119
Connector Name	IPDM E/R (INTELLIGENT POWER DISTRIBUTION MODULE ENGINE ROOM)
Connector Color	WHITE



Terminal No.	Color of Wire	Signal Name
28	P	CAN-L
29	L	CAN-H

Connector No.	E125
Connector Name	ABS ACTUATOR AND ELECTRIC UNIT (CONTROL UNIT)
Connector Color	BLACK

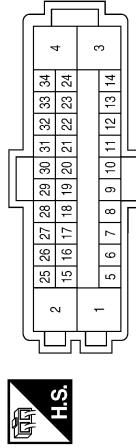

Terminal No.	Color of Wire	Signal Name
15	P	CAN-L
25	L	CAN-H

AAMIA1299GB

A
B
C
D
E
F
G
H
I
J
K
L
M
N
O
P

LAN

CAN SYSTEM (WITHOUT AROUND VIEW MONITOR SYSTEM)

< WIRING DIAGRAM >

[CAN]

Connector No.	E152
Connector Name	WIRE TO WIRE
Connector Color	WHITE

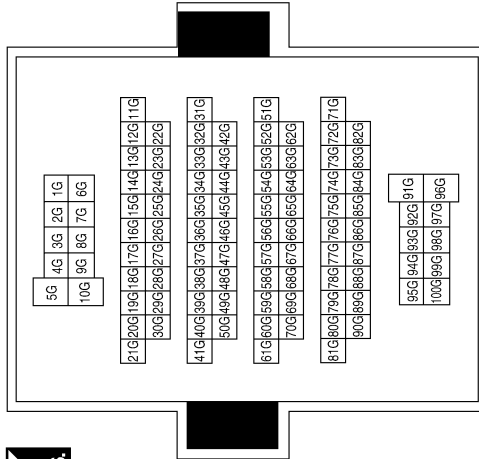

Terminal No.	Color of Wire	Signal Name
35G	P	-
36G	L	-

Connector No.	F15
Connector Name	TCM (TRANSMISSION CONTROL MODULE)
Connector Color	BLACK

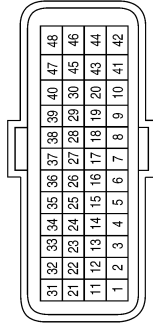

Terminal No.	Color of Wire	Signal Name
23	P	CAN-L
33	L	CAN-H

Connector No.	F32
Connector Name	WIRE TO WIRE
Connector Color	WHITE

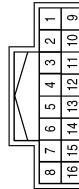

Connector No.	B11
Connector Name	JOINT CONNECTOR-B09
Connector Color	WHITE



Terminal No.	Color of Wire	Signal Name
9	P	-
10	L	-

Connector No.	B12
Connector Name	JOINT CONNECTOR-B10
Connector Color	WHITE



Terminal No.	Color of Wire	Signal Name
1	L	-
2	L	-
3	L	-

CAN SYSTEM (WITHOUT AROUND VIEW VIEW MONITOR SYSTEM)

< WIRING DIAGRAM >

[CAN]

Connector No.	B32
Connector Name	WIRE TO WIRE
Connector Color	WHITE

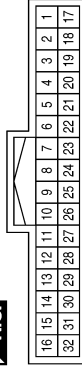

Terminal No.	Color of Wire	Signal Name
18	L	-
19	P	-

Connector No.	B17
Connector Name	JOINT CONNECTOR-B12
Connector Color	WHITE



Terminal No.	Color of Wire	Signal Name
1	L	-
2	L	-
3	L	-
4	B	-

Connector No.	B16
Connector Name	JOINT CONNECTOR-B11
Connector Color	WHITE



Terminal No.	Color of Wire	Signal Name
1	P	-
2	P	-
3	P	-
4	W	-

Connector No.	B67
Connector Name	4WD CONTROL UNIT
Connector Color	WHITE

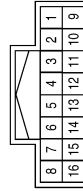

Terminal No.	Color of Wire	Signal Name
8	L	CAN-H
16	P	CAN-L

Connector No.	B55
Connector Name	AUTOMATIC BACK DOOR CONTROL MODULE
Connector Color	BLACK

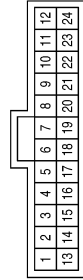

Terminal No.	Color of Wire	Signal Name
12	W	CAN-L
18	SHIELD	CAN SHIELD
24	B	CAN-H

Connector No.	B54
Connector Name	WIRE TO WIRE
Connector Color	BROWN

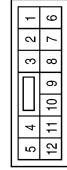

Terminal No.	Color of Wire	Signal Name
1	L	-
2	P	-

AAM1A1301GB

A
B
C
D
E
F
G
H
I
J
K
L
N
O
P

LAN

CAN SYSTEM (WITHOUT AROUND VIEW MONITOR SYSTEM)

< WIRING DIAGRAM >

[CAN]

Connector No.	B101
Connector Name	WIRE TO WIRE
Connector Color	WHITE



1	2	3	4	5	6	7	8	9	10	11	12	13	14	15	16
17	18	19	20	21	22	23	24	25	26	27	28	29	30	31	32

Terminal No.	Color of Wire	Signal Name
17	L	-
18	P	-

Terminal No.	Color of Wire	Signal Name
89A	L	-
90A	P	-

Connector No.	B69
Connector Name	WIRE TO WIRE
Connector Color	GRAY

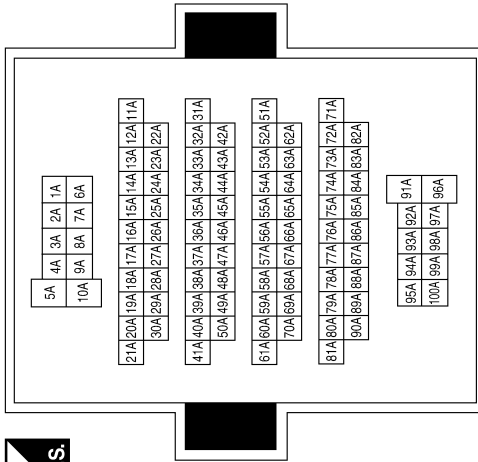

Connector No.	B209
Connector Name	DRIVER SEAT CONTROL UNIT
Connector Color	WHITE



16	15	14	13	12	11	10	9	8	7	6	5	4	3	2	1
32	31	30	29	28	27	26	25	24	23	22	21	20	19	18	17

Terminal NO.	Color of Wire	Signal Name
16	P	CAN-H
32	W	CAN-L

Connector No.	B200
Connector Name	WIRE TO WIRE
Connector Color	WHITE



1	2	3	4	5		
6	7	8	9	10	11	12

Terminal NO.	Color of Wire	Signal Name
1	P	-
2	W	-

Connector No.	B124
Connector Name	WIRE TO WIRE
Connector Color	WHITE



1	2	3	4	5	6	7	8	9	10	11	12	13	14	15	16
17	18	19	20	21	22	23	24	25	26	27	28	29	30	31	32

Terminal NO.	Color of Wire	Signal Name
18	L	-
19	P	-

AAM1A1302GB

CAN SYSTEM (WITH AROUND VIEW MONITOR SYSTEM)

[CAN]

< WIRING DIAGRAM >

CAN SYSTEM (WITH AROUND VIEW MONITOR SYSTEM)

Wiring Diagram

INFOID:000000008510094

CAN SYSTEM - WITH AROUND VIEW MONITOR SYSTEM

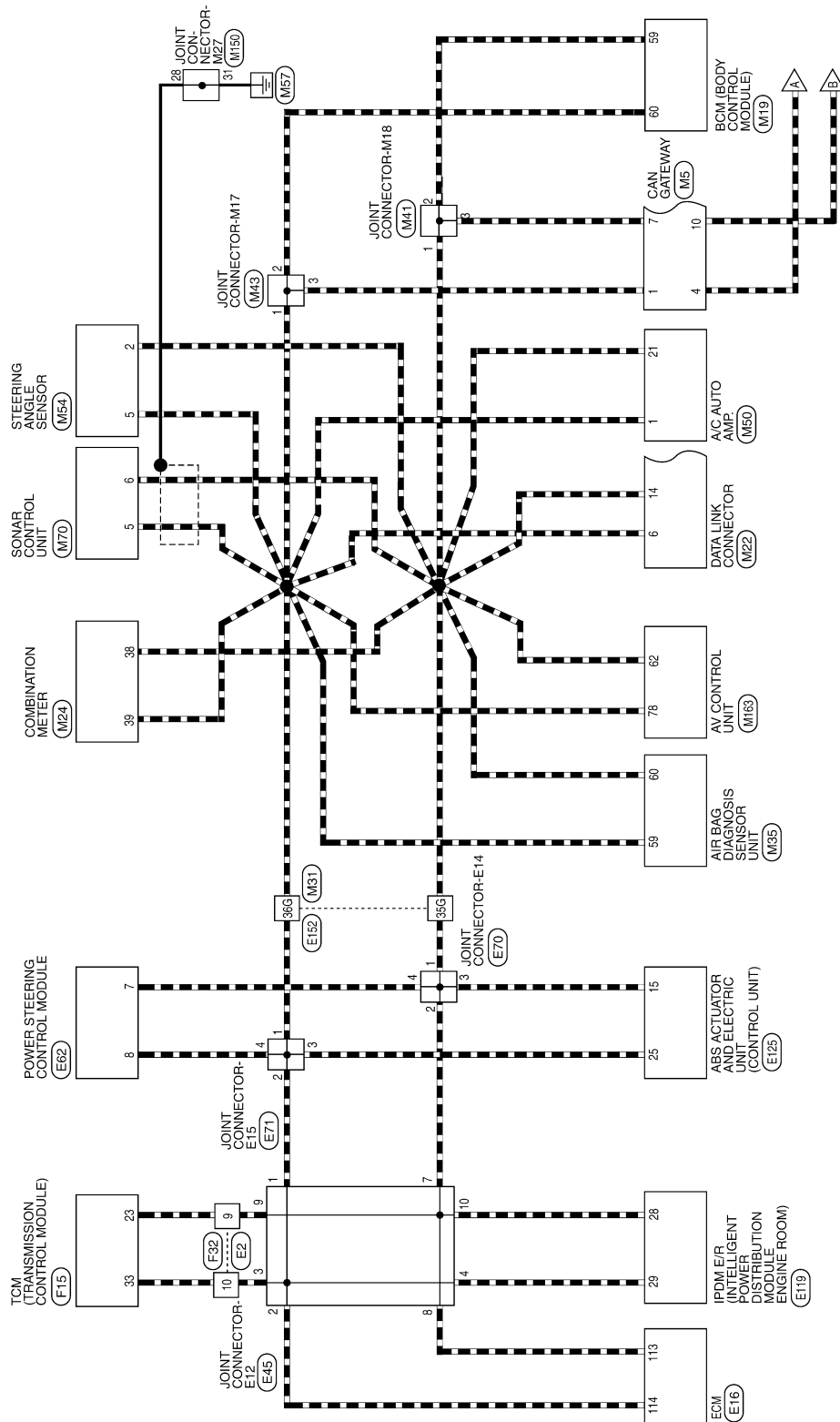

AAMWA0647GB

A
B
C
D
E
F
G
H
I
J
K
L
M
N
O
P

LAN

CAN SYSTEM (WITH AROUND VIEW MONITOR SYSTEM)

< WIRING DIAGRAM >

[CAN]

◀4W▶ WITH 4-WHEEL DRIVE

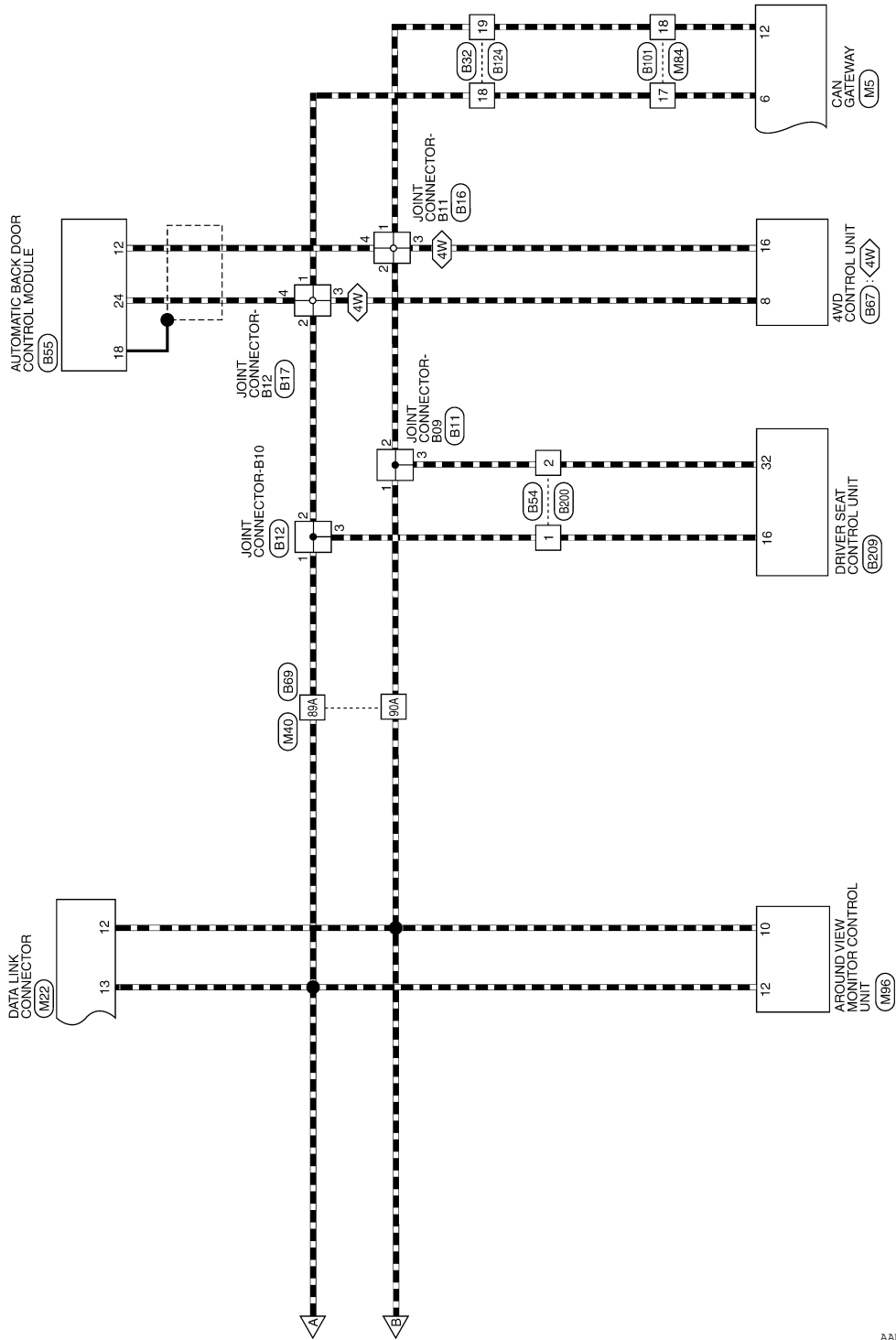

AAMWA0648GB

CAN SYSTEM (WITH AROUND VIEW MONITOR SYSTEM)

< WIRING DIAGRAM >

[CAN]

CAN SYSTEM CONNECTORS - WITH AROUND VIEW MONITOR

Connector No.	M5
Connector Name	CAN GATEWAY
Connector Color	WHITE

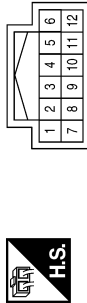

Terminal No.	Color of Wire	Signal Name
1	L	CAN-H
4	L	CAN-H
6	L	CAN-H
7	P	CAN-L
10	P	CAN-L
12	P	CAN-L

Connector No.	M19
Connector Name	BCM (BODY CONTROL MODULE)
Connector Color	BLACK



60	59	58	57	56	55	54	53	52	51	50	49	48	47	46	45	44	43	42	41	40	39	38	37	36	35	34	33	32	31	30	29	28	27	26	25	24	23	22	21	20	19	18	17	16	15	14	13	12	11	10	9	8	7	6	5	4	3	2	1
----	----	----	----	----	----	----	----	----	----	----	----	----	----	----	----	----	----	----	----	----	----	----	----	----	----	----	----	----	----	----	----	----	----	----	----	----	----	----	----	----	----	----	----	----	----	----	----	----	----	----	---	---	---	---	---	---	---	---	---

Terminal No.	Color of Wire	Signal Name
59	P	CAN-L
60	L	CAN-H

Connector No.	M22
Connector Name	DATA LINK CONNECTOR
Connector Color	WHITE

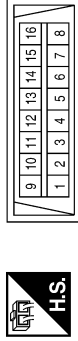

Terminal No.	Color of Wire	Signal Name
6	L	-
12	P	-
13	L	-
14	P	-

Connector No.	M24
Connector Name	COMBINATION METER
Connector Color	WHITE

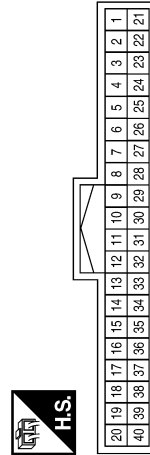

Terminal No.	Color of Wire	Signal Name
38	P	CAN-L
39	L	CAN-H

A
B
C
D
E
F
G
H
I
J
K
L
LAN
N
O
P

CAN SYSTEM (WITH AROUND VIEW MONITOR SYSTEM)

< WIRING DIAGRAM >

[CAN]

Connector No.	M40
Connector Name	WIRE TO WIRE
Connector Color	WHITE

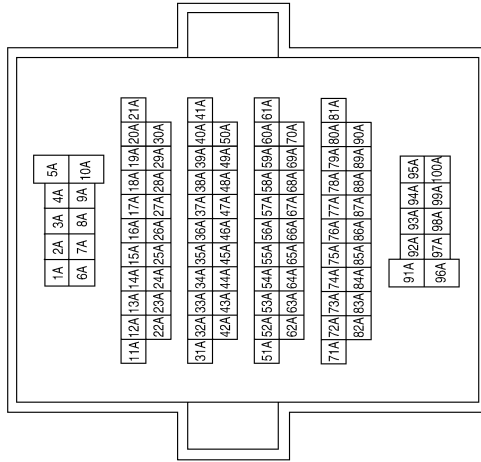

Terminal No.	Color of Wire	Signal Name
89A	L	-
90A	P	-

Connector No.	M35
Connector Name	AIR BAG DIAGNOSIS SENSOR UNIT
Connector Color	YELLOW

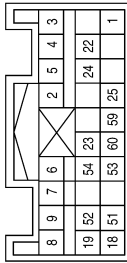

Terminal No.	Color of Wire	Signal Name
59	L	CAN-H
60	P	CAN-L

Connector No.	M31
Connector Name	WIRE TO WIRE
Connector Color	WHITE

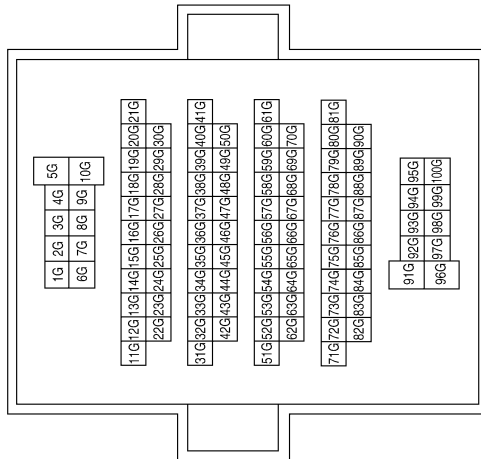

Terminal No.	Color of Wire	Signal Name
35G	P	-
36G	L	-

AAM1A1289GB

CAN SYSTEM (WITH AROUND VIEW MONITOR SYSTEM)

< WIRING DIAGRAM >

[CAN]

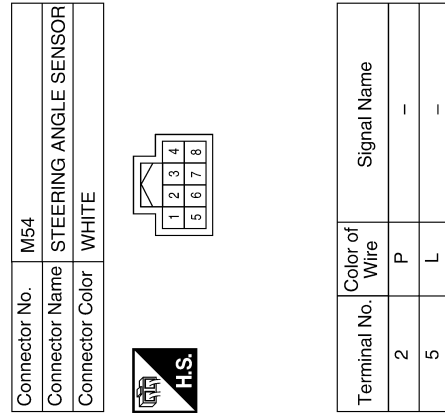
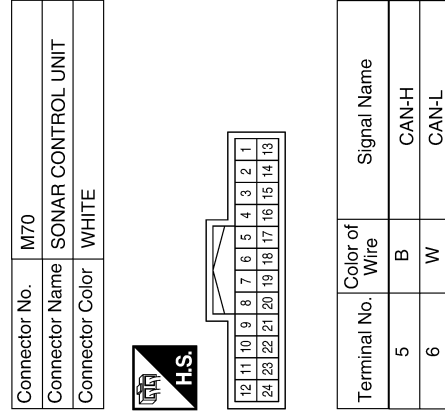
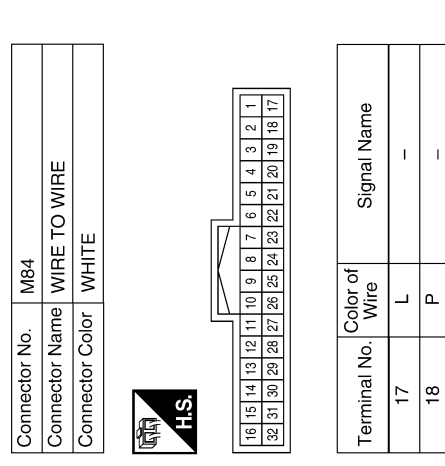
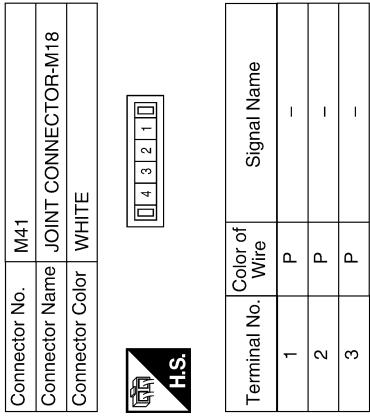
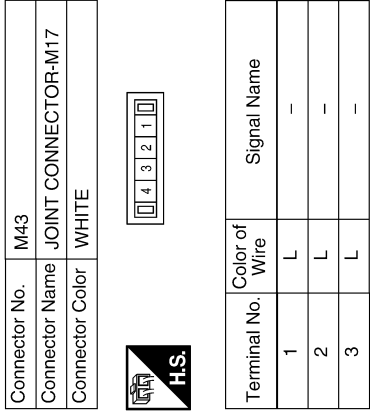
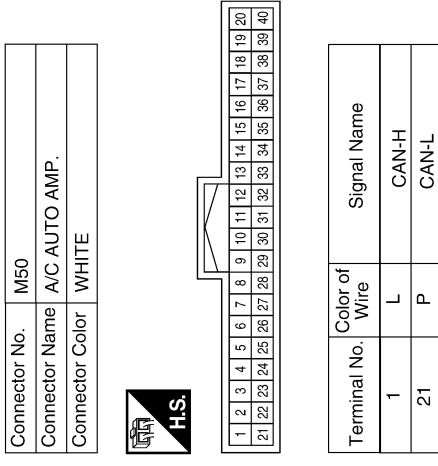

AAMIA1290GB

A
B
C
D
E
F
G
H
I
J
K
L
N
O
P

LAN

CAN SYSTEM (WITH AROUND VIEW MONITOR SYSTEM)

< WIRING DIAGRAM >

[CAN]

Connector No.	M96
Connector Name	AROUND VIEW MONITOR CONTROL UNIT
Connector Color	WHITE

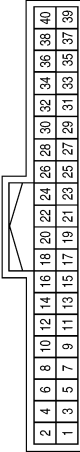

Terminal No.	Color of Wire	Signal Name
10	P	CAN-L
12	L	CAN-H

Connector No.	E2
Connector Name	WIRE TO WIRE
Connector Color	WHITE

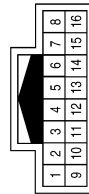

Terminal No.	Color of Wire	Signal Name
9	P	-
10	L	-

Connector No.	M150
Connector Name	JOINT CONNECTOR-M27
Connector Color	WHITE

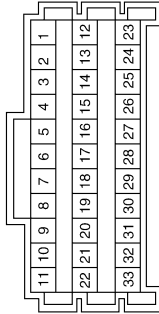

Terminal No.	Color of Wire	Signal Name
28	SHIELD	-
31	GR	-

Connector No.	E16
Connector Name	ECM
Connector Color	GRAY

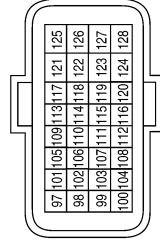

Terminal No.	Color of Wire	Signal Name
113	P	CAN-L
114	L	CAN-H

Connector No.	M163
Connector Name	AV CONTROL UNIT (WITH NAVIGATION SYSTEM AND BOSE AUDIO SYSTEM)
Connector Color	WHITE

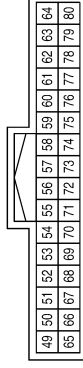

Terminal No.	Color of Wire	Signal Name
62	P	CAN-L
78	L	CAN-H

Connector No.	E45
Connector Name	JOINT CONNECTOR-E12
Connector Color	BLUE



Terminal No.	Color of Wire	Signal Name
1	L	-
2	L	-
3	L	-
4	L	-
7	P	-
8	P	-
9	P	-
10	P	-

AAMIA1291GB

CAN SYSTEM (WITH AROUND VIEW MONITOR SYSTEM)

< WIRING DIAGRAM >

[CAN]

Connector No.	E71
Connector Name	JOINT CONNECTOR-E15
Connector Color	BLACK

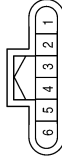

Terminal No.	Color of Wire	Signal Name
1	L	-
2	L	-
3	L	-
4	L	-

Connector No.	E70
Connector Name	JOINT CONNECTOR-E14
Connector Color	BLACK

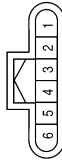

Terminal No.	Color of Wire	Signal Name
1	P	-
2	P	-
3	P	-
4	P	-

Connector No.	E62
Connector Name	POWER STEERING CONTROL MODULE
Connector Color	BLACK

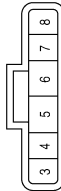

Terminal No.	Color of Wire	Signal Name
7	P	CAN-L
8	L	CAN-H

Connector No.	E125
Connector Name	ABS ACTUATOR AND ELECTRIC UNIT (CONTROL UNIT)
Connector Color	BLACK

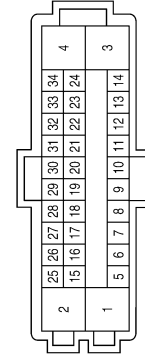

Terminal No.	Color of Wire	Signal Name
15	P	CAN-L
25	L	CAN-H

Connector No.	E119
Connector Name	IPDM E/R (INTELLIGENT POWER DISTRIBUTION MODULE ENGINE ROOM)
Connector Color	WHITE



Terminal No.	Color of Wire	Signal Name
28	P	CAN-L
29	L	CAN-H

AAMIA1292GB

A
B
C
D
E
F
G
H
I
J
K
L
N
O
P

LAN

CAN SYSTEM (WITH AROUND VIEW MONITOR SYSTEM)

< WIRING DIAGRAM >

[CAN]

Connector No.	F15
Connector Name	TCM (TRANSMISSION CONTROL MODULE)
Connector Color	BLACK

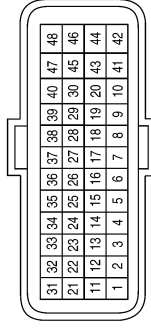

Terminal No.	Color of Wire	Signal Name
23	P	CAN-L
33	L	CAN-H

Terminal No.	Color of Wire	Signal Name
35G	P	-
36G	L	-

Connector No.	E152
Connector Name	WIRE TO WIRE
Connector Color	WHITE

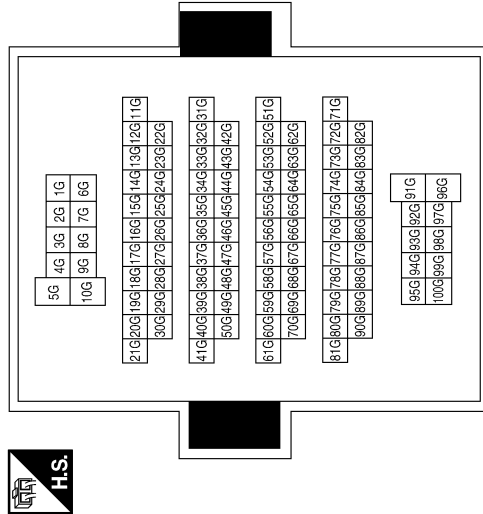

Connector No.	B12
Connector Name	JOINT CONNECTOR-B10
Connector Color	WHITE

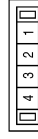

Terminal No.	Color of Wire	Signal Name
1	L	-
2	L	-
3	L	-

Connector No.	B11
Connector Name	JOINT CONNECTOR-B09
Connector Color	WHITE

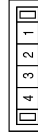

Terminal No.	Color of Wire	Signal Name
1	P	-
2	P	-
3	P	-

Connector No.	F32
Connector Name	WIRE TO WIRE
Connector Color	WHITE

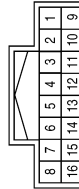

Terminal No.	Color of Wire	Signal Name
9	P	-
10	L	-

CAN SYSTEM (WITH AROUND VIEW MONITOR SYSTEM)

< WIRING DIAGRAM >

[CAN]

Connector No.	B32
Connector Name	WIRE TO WIRE
Connector Color	WHITE

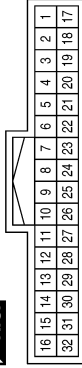

Terminal No.	Color of Wire	Signal Name
18	L	-
19	P	-

Connector No.	B17
Connector Name	JOINT CONNECTOR-B12
Connector Color	WHITE



Terminal No.	Color of Wire	Signal Name
1	L	-
2	L	-
3	L	-
4	B	-

Connector No.	B16
Connector Name	JOINT CONNECTOR-B11
Connector Color	WHITE



Terminal No.	Color of Wire	Signal Name
1	P	-
2	P	-
3	P	-
4	W	-

Connector No.	B67
Connector Name	4WD CONTROL UNIT
Connector Color	WHITE

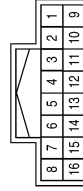

Terminal No.	Color of Wire	Signal Name
8	L	CAN-H
16	P	CAN-L

Connector No.	B55
Connector Name	AUTOMATIC BACK DOOR CONTROL MODULE
Connector Color	BLACK

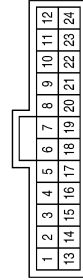

Terminal No.	Color of Wire	Signal Name
12	W	CAN-L
18	SHIELD	CAN SHIELD
24	B	CAN-H

Connector No.	B54
Connector Name	WIRE TO WIRE
Connector Color	BROWN



Terminal No.	Color of Wire	Signal Name
1	L	-
2	P	-

AAMIA1294GB

A
B
C
D
E
F
G
H
I
J
K
L
M
N
O
P

LAN

CAN SYSTEM (WITH AROUND VIEW MONITOR SYSTEM)

< WIRING DIAGRAM >

[CAN]

Connector No.	B101
Connector Name	WIRE TO WIRE
Connector Color	WHITE

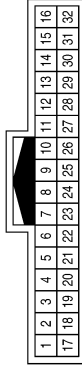

Terminal No.	Color of Wire	Signal Name
17	L	-
18	P	-

Terminal No.	Color of Wire	Signal Name
89A	L	-
90A	P	-

Connector No.	B69
Connector Name	WIRE TO WIRE
Connector Color	GRAY

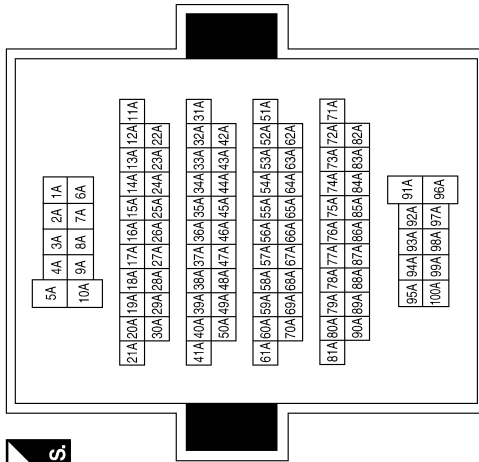

Connector No.	B209
Connector Name	DRIVER SEAT CONTROL UNIT
Connector Color	WHITE

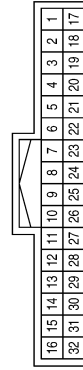

Terminal No.	Color of Wire	Signal Name
16	P	CAN-H
32	W	CAN-L

Connector No.	B200
Connector Name	WIRE TO WIRE
Connector Color	WHITE

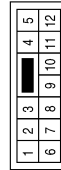

Terminal No.	Color of Wire	Signal Name
1	P	-
2	W	-

Connector No.	B124
Connector Name	WIRE TO WIRE
Connector Color	WHITE

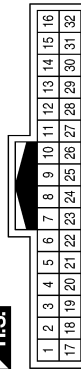

Terminal No.	Color of Wire	Signal Name
18	L	-
19	P	-

AAM1A1295GB

DIAGNOSIS AND REPAIR WORKFLOW

< BASIC INSPECTION >

[CAN]

BASIC INSPECTION

DIAGNOSIS AND REPAIR WORKFLOW

Interview Sheet

INFOID:000000008510095

NOTE:

Refer to [LAN-20. "Trouble Diagnosis Procedure"](#) for how to use interview sheet.

CAN Communication System Diagnosis Interview Sheet	
Date received:	<input type="text"/>
Type:	<input type="text"/>
VIN No.:	<input type="text"/>
Model:	<input type="text"/>
First registration:	<input type="text"/>
Mileage:	<input type="text"/>
CAN system type:	<input type="text"/>
Symptom (Results from interview with customer)	
<input type="text"/>	
Condition at inspection	
Error symptom : Present / Past	
<input type="text"/>	

SKIB8898E

A
B
C
D
E
F
G
H
I
J
K
L
LAN
N
O
P

MALFUNCTION AREA CHART

< DTC/CIRCUIT DIAGNOSIS >

[CAN]

DTC/CIRCUIT DIAGNOSIS

MALFUNCTION AREA CHART

Main Line

INFOID:000000008510096

Malfunction area	Reference
Main line between IPDM E/R and ABS actuator and electric unit (control unit)	LAN-61, "Diagnosis Procedure"
Main line between ABS actuator and electric unit (control unit) and data link connector	LAN-62, "Diagnosis Procedure"
Main line between data link connector and 4WD control unit	LAN-63, "Diagnosis Procedure"
Main line between data link connector and driver seat control unit	LAN-64, "Diagnosis Procedure"
Main line between driver seat control unit and automatic back door control module	LAN-65, "Diagnosis Procedure"
Main line between data link connector and CAN gateway	LAN-66, "Diagnosis Procedure"

Branch Line

INFOID:000000008968030

Malfunction area	Reference
ECM branch line circuit	LAN-67, "Diagnosis Procedure"
IPDM E/R branch line circuit	LAN-68, "Diagnosis Procedure"
TCM branch line circuit	LAN-69, "Diagnosis Procedure"
ABS actuator and electric unit (control unit) branch line circuit	LAN-70, "Diagnosis Procedure"
Power steering control module branch line circuit	LAN-71, "Diagnosis Procedure"
Air bag diagnosis sensor unit branch line circuit	LAN-72, "Diagnosis Procedure"
AV control unit branch line circuit	LAN-73, "Diagnosis Procedure"
Data link connector branch line circuit	LAN-74, "Diagnosis Procedure"
Data link connector branch line circuit (CAN communication circuit 1)	LAN-75, "Diagnosis Procedure"
Data link connector branch line circuit (CAN communication circuit 2)	LAN-76, "Diagnosis Procedure"
A/C auto amp. branch line circuit	LAN-77, "Diagnosis Procedure"
Combination meter branch line circuit	LAN-78, "Diagnosis Procedure"
Sonar control unit branch line circuit	LAN-79, "Diagnosis Procedure"
Steering angle sensor branch line circuit	LAN-80, "Diagnosis Procedure"
Driver seat control unit branch line circuit	LAN-81, "Diagnosis Procedure"
4WD control unit branch line circuit	LAN-82, "Diagnosis Procedure"
Automatic back door control module branch line circuit	LAN-83, "Diagnosis Procedure"
BCM branch line circuit	LAN-84, "Diagnosis Procedure"
CAN gateway branch line circuit (CAN communication circuit 1)	LAN-85, "Diagnosis Procedure"
CAN gateway branch line circuit (CAN communication circuit 2)	LAN-86, "Diagnosis Procedure"
Around view monitor control unit branch line circuit	LAN-87, "Diagnosis Procedure"

Short Circuit

INFOID:000000008968031

Malfunction area	Reference
CAN communication circuit	LAN-88, "Diagnosis Procedure"
CAN communication circuit 1	LAN-90, "Diagnosis Procedure"
CAN communication circuit 2	LAN-92, "Diagnosis Procedure"

MAIN LINE BETWEEN IPDM-E AND ABS CIRCUIT

< DTC/CIRCUIT DIAGNOSIS >

[CAN]

MAIN LINE BETWEEN IPDM-E AND ABS CIRCUIT

Diagnosis Procedure

INFOID:000000008510098

1. CHECK HARNESS CONTINUITY (OPEN CIRCUIT)

1. Turn the ignition switch OFF.
2. Disconnect the battery cable from the negative terminal.
3. Disconnect the following harness connectors.
 - ECM
 - IPDM E/R
 - ABS actuator and electric unit (control unit)
4. Check the continuity between the IPDM E/R harness connector and the ABS actuator and electric unit (control unit) harness connector.

IPDM E/R harness connector		ABS actuator and electric unit (control unit) harness connector		Continuity
Connector No.	Terminal No.	Connector No.	Terminal No.	
E119	29	E125	25	Existed
	28		15	Existed

Is the inspection result normal?

YES (Present error)>>Check CAN system type decision again.

YES (Past error)>>Error was detected in the main line between the IPDM E/R and the ABS actuator and electric unit (control unit).

NO >> Repair the main line between the IPDM E/R and the ABS actuator and electric unit (control unit).

A
B
C
D
E
F
G
H
I
J
K
L
N
O
P

LAN

MAIN LINE BETWEEN ABS AND DLC CIRCUIT

< DTC/CIRCUIT DIAGNOSIS >

[CAN]

MAIN LINE BETWEEN ABS AND DLC CIRCUIT

Diagnosis Procedure

INFOID:000000008510099

1. CHECK CONNECTOR

1. Turn the ignition switch OFF.
2. Disconnect the battery cable from the negative terminal.
3. Check the following terminals and connectors for damage, bend and loose connection (connector side and harness side).
 - Harness connector E152
 - Harness connector M31

Is the inspection result normal?

YES >> GO TO 2.

NO >> Repair the terminal and connector.

2. CHECK HARNESS CONTINUITY (OPEN CIRCUIT)

1. Disconnect the following harness connectors.
 - ABS actuator and electric unit (control unit)
 - Harness connectors E152 and M31.
2. Check the continuity between the ABS actuator and electric unit (control unit) harness connector and the harness connector.

ABS actuator and electric unit (control unit) harness connector		Harness connector		Continuity
Connector No.	Terminal No.	Connector No.	Terminal No.	
E125	25	E152	36G	Existed
	15		35G	Existed

Is the inspection result normal?

YES >> GO TO 3.

NO >> Repair the main line between the ABS actuator and electric unit (control unit) and the harness connector E152.

3. CHECK HARNESS CONTINUITY (OPEN CIRCUIT)

Check the continuity between the harness connector and the data link connector.

Harness connector		Data link connector		Continuity
Connector No.	Terminal No.	Connector No.	Terminal No.	
M31	36G	M22	6	Existed
	35G		14	Existed

Is the inspection result normal?

YES (Present error)>>Check CAN system type decision again.

YES (Past error)>>Error was detected in the main line between the ABS actuator and electric unit (control unit) and the data link connector.

NO >> Repair the main line between the harness connector M31 and the data link connector.

MAIN LINE BETWEEN DLC AND 4WD CIRCUIT

< DTC/CIRCUIT DIAGNOSIS >

[CAN]

MAIN LINE BETWEEN DLC AND 4WD CIRCUIT

Diagnosis Procedure

INFOID:000000008510100

1. CHECK CONNECTOR

1. Turn the ignition switch OFF.
2. Disconnect the battery cable from the negative terminal.
3. Check the following terminals and connectors for damage, bend and loose connection (connector side and harness side).
 - Harness connector M40
 - Harness connector B69

Is the inspection result normal?

YES >> GO TO 2.

NO >> Repair the terminal and connector.

2. CHECK HARNESS CONTINUITY (OPEN CIRCUIT)

1. Disconnect the harness connectors M40 and B69.
2. Check the continuity between the data link connector and the harness connector.

Data link connector		Harness connector		Continuity
Connector No.	Terminal No.	Connector No.	Terminal No.	
M22	6	M40	89A	Existed
	14		90A	Existed

Is the inspection result normal?

YES >> GO TO 3.

NO >> Repair the main line between the data link connector and the harness connector M40.

3. CHECK HARNESS CONTINUITY (OPEN CIRCUIT)

1. Disconnect the connector of 4WD control unit.
2. Check the continuity between the harness connector and the 4WD control unit harness connector.

Harness connector		4WD control unit harness connector		Continuity
Connector No.	Terminal No.	Connector No.	Terminal No.	
B69	89A	B67	8	Existed
	90A		16	Existed

Is the inspection result normal?

YES (Present error)>>Check CAN system type decision again.

YES (Past error)>>Error was detected in the main line between the data link connector and the 4WD control unit.

NO >> Repair the main line between the harness connector B69 and the 4WD control unit.

A
B
C
D
E
F
G
H
I
J
K
L
N
O
P

LAN

MAIN LINE BETWEEN DLC AND ADP CIRCUIT

< DTC/CIRCUIT DIAGNOSIS >

[CAN]

MAIN LINE BETWEEN DLC AND ADP CIRCUIT

Diagnosis Procedure

INFOID:000000008510102

1.CHECK CONNECTOR

1. Turn the ignition switch OFF.
2. Disconnect the battery cable from the negative terminal.
3. Check the following terminals and connectors for damage, bend and loose connection (connector side and harness side).
 - Harness connector M40
 - Harness connector B69

Is the inspection result normal?

YES >> GO TO 2.

NO >> Repair the terminal and connector.

2.CHECK HARNESS CONTINUITY (OPEN CIRCUIT)

1. Disconnect the harness connectors M40 and B69.
2. Check the continuity between the data link connector and the harness connector.
 - Without around view monitor

Data link connector		Harness connector		Continuity
Connector No.	Terminal No.	Connector No.	Terminal No.	
M22	6	M40	89A	Existed
	14		90A	Existed

- With around view monitor

Data link connector		Harness connector		Continuity
Connector No.	Terminal No.	Connector No.	Terminal No.	
M22	13	M40	89A	Existed
	12		90A	Existed

Is the inspection result normal?

YES >> GO TO 3.

NO >> Repair the main line between the data link connector and the harness connector M40.

3.CHECK HARNESS CONTINUITY (OPEN CIRCUIT)

1. Disconnect the harness connectors B54 and B200.
2. Check the continuity between the harness connectors

Harness connector		Harness connector		Continuity
Connector No.	Terminal No.	Connector No.	Terminal No.	
B69	89A	B54	2	Existed
	90A		1	Existed

Is the inspection result normal?

YES (Present error)>>Check CAN system type decision again.

YES (Past error)>>Error was detected in the main line between the data link connector and the driver seat control unit.

NO >> Repair the main line between the harness connectors B69 and B54.

MAIN LINE BETWEEN ADP AND PWBD CIRCUIT

< DTC/CIRCUIT DIAGNOSIS >

[CAN]

MAIN LINE BETWEEN ADP AND PWBD CIRCUIT

Diagnosis Procedure

INFOID:000000008510103

1. CHECK HARNESS CONTINUITY (OPEN CIRCUIT)

1. Turn the ignition switch OFF.
2. Disconnect the battery cable from the negative terminal.
3. Disconnect the following harness connectors.
 - ECM (Models without around view monitor)
 - CAN gateway (Models with around view monitor)
 - Harness connector B54 and B200
 - Automatic back door control module
4. Check the continuity between the harness connector and the automatic back door control module harness connector.

Harness connector		Automatic back door control module harness connector		Continuity
Connector No.	Terminal No.	Connector No.	Terminal No.	
B54	1	B55	24	Existed
	2		12	Existed

Is the inspection result normal?

YES (Present error)>>Check CAN system type decision again.

YES (Past error)>>Error was detected in the main line between the driver seat control unit and the automatic back door control module.

NO >> Repair the main line between the harness connector B54 and the automatic back door control module.

A
B
C
D
E
F
G
H
I
J
K
L

LAN

N
O
P

MAIN LINE BETWEEN DLC AND CGW CIRCUIT

< DTC/CIRCUIT DIAGNOSIS >

[CAN]

MAIN LINE BETWEEN DLC AND CGW CIRCUIT

Diagnosis Procedure

INFOID:000000008510101

1. CHECK HARNESS CONTINUITY (OPEN CIRCUIT)

1. Turn the ignition switch OFF.
2. Disconnect the battery cable from the negative terminal.
3. Disconnect the following harness connectors.
 - ECM
 - CAN gateway
4. Check the continuity between the data link connector and the CAN gateway harness connector.

Data link connector		CAN gateway harness connector		Continuity
Connector No.	Terminal No.	Connector No.	Terminal No.	
M22	6	M5	1	Existed
	14		7	Existed

Is the inspection result normal?

YES (Present error)>>Check CAN system type decision again.

YES (Past error)>>Error was detected in the main line between the data link connector and the CAN gateway.

NO >> Repair the main line between the data link connector and the CAN gateway.

ECM BRANCH LINE CIRCUIT

< DTC/CIRCUIT DIAGNOSIS >

[CAN]

ECM BRANCH LINE CIRCUIT

Diagnosis Procedure

INFOID:000000008510109

1. CHECK CONNECTOR

1. Turn the ignition switch OFF.
2. Disconnect the battery cable from the negative terminal.
3. Check the terminals and connectors of the ECM for damage, bend and loose connection (unit side and connector side).

Is the inspection result normal?

- YES >> GO TO 2.
NO >> Repair the terminal and connector.

2. CHECK HARNESS FOR OPEN CIRCUIT

1. Disconnect the connector of ECM.
2. Check the resistance between the ECM harness connector terminals.

ECM harness connector			Resistance (Ω)
Connector No.	Terminal No.		
E16	114	113	Approx. 108 – 132

Is the measurement value within the specification?

- YES >> GO TO 3.
NO >> Repair the ECM branch line.

3. CHECK POWER SUPPLY AND GROUND CIRCUIT

Check the power supply and the ground circuit of the ECM. Refer to [EC-170. "Diagnosis Procedure"](#).

Is the inspection result normal?

- YES (Present error)>>Replace the ECM. Refer to [EC-460. "Removal and Installation"](#).
YES (Past error)>>Error was detected in the ECM branch line.
NO >> Repair the power supply and the ground circuit.

A
B
C
D
E
F
G
H
I
J
K
L

LAN

N
O
P

IPDM-E BRANCH LINE CIRCUIT

< DTC/CIRCUIT DIAGNOSIS >

[CAN]

IPDM-E BRANCH LINE CIRCUIT

Diagnosis Procedure

INFOID:000000008510110

1. CHECK CONNECTOR

1. Turn the ignition switch OFF.
2. Disconnect the battery cable from the negative terminal.
3. Check the terminals and connectors of the IPDM E/R for damage, bend and loose connection (unit side and connector side).

Is the inspection result normal?

- YES >> GO TO 2.
NO >> Repair the terminal and connector.

2. CHECK HARNESS FOR OPEN CIRCUIT

1. Disconnect the connector of IPDM E/R.
2. Check the resistance between the IPDM E/R harness connector terminals.

IPDM E/R harness connector			Resistance (Ω)
Connector No.	Terminal No.		
E119	29	28	Approx. 54 – 66

Is the measurement value within the specification?

- YES >> GO TO 3.
NO >> Repair the IPDM E/R branch line.

3. CHECK POWER SUPPLY AND GROUND CIRCUIT

Check the power supply and the ground circuit of the IPDM E/R. Refer to [PCS-31, "Diagnosis Procedure"](#).

Is the inspection result normal?

- YES (Present error)>>Replace the IPDM E/R. Refer to [PCS-32, "Removal and Installation"](#).
YES (Past error)>>Error was detected in the IPDM E/R branch line.
NO >> Repair the power supply and the ground circuit.

TCM BRANCH LINE CIRCUIT

< DTC/CIRCUIT DIAGNOSIS >

[CAN]

TCM BRANCH LINE CIRCUIT

Diagnosis Procedure

INFOID:000000008510111

1. CHECK CONNECTOR

1. Turn the ignition switch OFF.
2. Disconnect the battery cable from the negative terminal.
3. Check the following terminals and connectors for damage, bend and loose connection (unit side and connector side).
 - TCM
 - Harness connector F32
 - Harness connector E2

Is the inspection result normal?

- YES >> GO TO 2.
NO >> Repair the terminal and connector.

2. CHECK HARNESS FOR OPEN CIRCUIT

1. Disconnect the connector of TCM.
2. Check the resistance between the TCM harness connector terminals.

TCM harness connector			Resistance (Ω)
Connector No.	Terminal No.		
F15	33	23	Approx. 54 – 66

Is the measurement value within the specification?

- YES >> GO TO 3.
NO >> Repair the TCM branch line.

3. CHECK POWER SUPPLY AND GROUND CIRCUIT

Check the power supply and the ground circuit of the TCM. Refer to [TM-165, "Diagnosis Procedure"](#).

Is the inspection result normal?

- YES (Present error)>>Replace the TCM. Refer to [TM-197, "Removal and Installation"](#).
YES (Past error)>>Error was detected in the TCM branch line.
NO >> Repair the power supply and the ground circuit.

A
B
C
D
E
F
G
H
I
J
K
L

LAN

ABS BRANCH LINE CIRCUIT

< DTC/CIRCUIT DIAGNOSIS >

[CAN]

ABS BRANCH LINE CIRCUIT

Diagnosis Procedure

INFOID:000000008510112

1. CHECK CONNECTOR

1. Turn the ignition switch OFF.
2. Disconnect the battery cable from the negative terminal.
3. Check the terminals and connectors of the ABS actuator and electric unit (control unit) for damage, bend and loose connection (unit side and connector side).

Is the inspection result normal?

- YES >> GO TO 2.
NO >> Repair the terminal and connector.

2. CHECK HARNESS FOR OPEN CIRCUIT

1. Disconnect the connector of ABS actuator and electric unit (control unit).
2. Check the resistance between the ABS actuator and electric unit (control unit) harness connector terminals.

ABS actuator and electric unit (control unit) harness connector			Resistance (Ω)
Connector No.	Terminal No.		
E125	25	15	Approx. 54 – 66

Is the measurement value within the specification?

- YES >> GO TO 3.
NO >> Repair the ABS actuator and electric unit (control unit) branch line.

3. CHECK POWER SUPPLY AND GROUND CIRCUIT

Check the power supply and the ground circuit of the ABS actuator and electric unit (control unit). Refer to [BRC-63. "Diagnosis Procedure"](#).

Is the inspection result normal?

- YES (Present error)>>Replace the ABS actuator and electric unit (control unit). Refer to [BRC-121. "Removal and Installation"](#).
YES (Past error)>>Error was detected in the ABS actuator and electric unit (control unit) branch line.
NO >> Repair the power supply and the ground circuit.

EPS BRANCH LINE CIRCUIT

< DTC/CIRCUIT DIAGNOSIS >

[CAN]

EPS BRANCH LINE CIRCUIT

Diagnosis Procedure

INFOID:000000008510113

1. CHECK CONNECTOR

1. Turn the ignition switch OFF.
2. Disconnect the battery cable from the negative terminal.
3. Check the terminals and connectors of the power steering control module for damage, bend and loose connection (unit side and connector side).

Is the inspection result normal?

- YES >> GO TO 2.
NO >> Repair the terminal and connector.

2. CHECK HARNESS FOR OPEN CIRCUIT

1. Disconnect the connector of power steering control module.
2. Check the resistance between the power steering control module harness connector terminals.

Power steering control module harness connector			Resistance (Ω)
Connector No.	Terminal No.		
E62	8	7	Approx. 54 – 66

Is the measurement value within the specification?

- YES >> GO TO 3.
NO >> Repair the power steering control module branch line.

3. CHECK POWER SUPPLY AND GROUND CIRCUIT

Check the power supply and the ground circuit of the power steering control module. Refer to [STC-22, "Diagnosis Procedure"](#).

Is the inspection result normal?

- YES (Present error)>>Replace the power steering oil pump assembly. Refer to [ST-51, "Removal and Installation"](#).
YES (Past error)>>Error was detected in the power steering control module branch line.
NO >> Repair the power supply and the ground circuit.

A
B
C
D
E
F
G
H
I
J
K
L

LAN

A-BAG BRANCH LINE CIRCUIT

< DTC/CIRCUIT DIAGNOSIS >

[CAN]

A-BAG BRANCH LINE CIRCUIT

Diagnosis Procedure

INFOID:000000008510114

WARNING:

- Before servicing, turn ignition switch OFF, disconnect battery negative terminal, and wait 3 minutes or more. (To discharge backup capacitor.)
- Never use unspecified tester or other measuring device.

1.CHECK CONNECTOR

1. Turn the ignition switch OFF.
2. Disconnect the battery cable from the negative terminal.
3. Check the terminals and connectors of the air bag diagnosis sensor unit for damage, bend and loose connection (unit side and connector side).

Is the inspection result normal?

- YES >> GO TO 2.
NO >> Replace the main harness.

2.CHECK AIR BAG DIAGNOSIS SENSOR UNIT

Check the air bag diagnosis sensor unit. Refer to [SRC-40, "Work Flow"](#).

Is the inspection result normal?

- YES >> Replace the main harness.
NO >> Replace parts whose air bag system has a malfunction.

AV BRANCH LINE CIRCUIT

< DTC/CIRCUIT DIAGNOSIS >

[CAN]

AV BRANCH LINE CIRCUIT

Diagnosis Procedure

INFOID:000000008510115

1. CHECK CONNECTOR

1. Turn the ignition switch OFF.
2. Disconnect the battery cable from the negative terminal.
3. Check the terminals and connectors of the AV control unit for damage, bend and loose connection (unit side and connector side).

Is the inspection result normal?

- YES >> GO TO 2.
NO >> Repair the terminal and connector.

2. CHECK HARNESS FOR OPEN CIRCUIT

1. Disconnect the connector of AV control unit.
 2. Check the resistance between the AV control unit harness connector terminals.
- With BOSE audio without navigation

AV control unit harness connector			Resistance (Ω)
Connector No.	Terminal No.		
M42	11	12	Approx. 54 – 66

- Without BOSE audio with navigation

AV control unit harness connector			Resistance (Ω)
Connector No.	Terminal No.		
M124	11	12	Approx. 54 – 66

- With BOSE audio with navigation

AV control unit harness connector			Resistance (Ω)
Connector No.	Terminal No.		
M163	78	62	Approx. 54 – 66

Is the measurement value within the specification?

- YES >> GO TO 3.
NO >> Repair the AV control unit branch line.

3. CHECK POWER SUPPLY AND GROUND CIRCUIT

Check the power supply and the ground circuit of the AV control unit. Refer to the following.

- Mid audio without BOSE: [AV-143, "AV CONTROL UNIT : Diagnosis Procedure"](#)
- Mid audio with BOSE: [AV-303, "AV CONTROL UNIT : Diagnosis Procedure"](#)
- Premium audio with navigation: [AV-532, "AV CONTROL UNIT : Diagnosis Procedure"](#)

Is the inspection result normal?

- YES (Present error)>>Replace the AV control unit. Refer to the following.
- Mid audio without BOSE: [AV-186, "Removal and Installation"](#)
 - Mid audio with BOSE: [AV-357, "Removal and Installation"](#)
 - Premium audio with navigation: [AV-585, "Removal and Installation"](#)

YES (Past error)>>Error was detected in the AV control unit branch line.

- NO >> Repair the power supply and the ground circuit.

A
B
C
D
E
F
G
H
I
J
K
L
N
O
P

LAN

DLC BRANCH LINE CIRCUIT

< DTC/CIRCUIT DIAGNOSIS >

[CAN]

DLC BRANCH LINE CIRCUIT

Diagnosis Procedure

INFOID:000000008510116

1. CHECK CONNECTOR

1. Turn the ignition switch OFF.
2. Disconnect the battery cable from the negative terminal.
3. Check the terminals and connectors of the data link connector for damage, bend and loose connection (connector side and harness side).

Is the inspection result normal?

- YES >> GO TO 2.
NO >> Repair the terminal and connector.

2. CHECK HARNESS FOR OPEN CIRCUIT

Check the resistance between the data link connector terminals.

Data link connector			Resistance (Ω)
Connector No.	Terminal No.		
M22	6	14	Approx. 54 – 66

Is the measurement value within the specification?

- YES (Present error)>>Check CAN system type decision again.
YES (Past error)>>Error was detected in the data link connector branch line circuit.
NO >> Repair the data link connector branch line.

DLC BRANCH LINE CIRCUIT (CAN COMMUNICATION CIRCUIT 1)

< DTC/CIRCUIT DIAGNOSIS >

[CAN]

DLC BRANCH LINE CIRCUIT (CAN COMMUNICATION CIRCUIT 1)

Diagnosis Procedure

INFOID:000000008510117

1. CHECK CONNECTOR

1. Turn the ignition switch OFF.
2. Disconnect the battery cable from the negative terminal.
3. Check the terminals and connectors of the data link connector for damage, bend and loose connection (connector side and harness side).

Is the inspection result normal?

- YES >> GO TO 2.
NO >> Repair the terminal and connector.

2. CHECK HARNESS FOR OPEN CIRCUIT

Check the resistance between the data link connector terminals.

Data link connector			Resistance (Ω)
Connector No.	Terminal No.		
M22	6	14	Approx. 54 – 66

Is the measurement value within the specification?

- YES (Present error)>>Check CAN system type decision again.
YES (Past error)>>Error was detected in the data link connector branch line circuit (CAN communication circuit 1 side).
NO >> Repair the data link connector branch line (CAN communication circuit 1 side).

A
B
C
D
E
F
G
H
I
J
K
L
N
O
P

LAN

DLC BRANCH LINE CIRCUIT (CAN COMMUNICATION CIRCUIT 2)

< DTC/CIRCUIT DIAGNOSIS >

[CAN]

DLC BRANCH LINE CIRCUIT (CAN COMMUNICATION CIRCUIT 2)

Diagnosis Procedure

INFOID:000000008510118

1. CHECK CONNECTOR

1. Turn the ignition switch OFF.
2. Disconnect the battery cable from the negative terminal.
3. Check the terminals and connectors of the data link connector for damage, bend and loose connection (connector side and harness side).

Is the inspection result normal?

- YES >> GO TO 2.
NO >> Repair the terminal and connector.

2. CHECK HARNESS FOR OPEN CIRCUIT

Check the resistance between the data link connector terminals.

Data link connector			Resistance (Ω)
Connector No.	Terminal No.		
M22	13	12	Approx. 54 – 66

Is the measurement value within the specification?

- YES (Present error)>>Check CAN system type decision again.
YES (Past error)>>Error was detected in the data link connector branch line circuit (CAN communication circuit 2 side).
NO >> Repair the data link connector branch line (CAN communication circuit 2 side).

HVAC BRANCH LINE CIRCUIT

< DTC/CIRCUIT DIAGNOSIS >

[CAN]

HVAC BRANCH LINE CIRCUIT

Diagnosis Procedure

INFOID:000000008510119

1. CHECK CONNECTOR

1. Turn the ignition switch OFF.
2. Disconnect the battery cable from the negative terminal.
3. Check the terminals and connectors of the A/C auto amp. for damage, bend and loose connection (unit side and connector side).

Is the inspection result normal?

- YES >> GO TO 2.
NO >> Repair the terminal and connector.

2. CHECK HARNESS FOR OPEN CIRCUIT

1. Disconnect the connector of A/C auto amp.
2. Check the resistance between the A/C auto amp. harness connector terminals.

A/C auto amp. harness connector			Resistance (Ω)
Connector No.	Terminal No.		
M50	1	21	Approx. 54 – 66

Is the measurement value within the specification?

- YES >> GO TO 3.
NO >> Repair the A/C auto amp. branch line.

3. CHECK POWER SUPPLY AND GROUND CIRCUIT

Check the power supply and the ground circuit of the A/C auto amp. Refer to [HAC-113, "A/C AUTO AMP. : Diagnosis Procedure"](#).

Is the inspection result normal?

- YES (Present error)>>Replace the A/C auto amp. Refer to [HAC-156, "Removal and Installation"](#).
YES (Past error)>>Error was detected in the A/C auto amp. branch line.
NO >> Repair the power supply and the ground circuit.

A
B
C
D
E
F
G
H
I
J
K
L

LAN

N
O
P

M&A BRANCH LINE CIRCUIT

< DTC/CIRCUIT DIAGNOSIS >

[CAN]

M&A BRANCH LINE CIRCUIT

Diagnosis Procedure

INFOID:000000008510120

1. CHECK CONNECTOR

1. Turn the ignition switch OFF.
2. Disconnect the battery cable from the negative terminal.
3. Check the terminals and connectors of the combination meter for damage, bend and loose connection (unit side and connector side).

Is the inspection result normal?

- YES >> GO TO 2.
NO >> Repair the terminal and connector.

2. CHECK HARNESS FOR OPEN CIRCUIT

1. Disconnect the connector of combination meter.
2. Check the resistance between the combination meter harness connector terminals.

Combination meter harness connector			Resistance (Ω)
Connector No.	Terminal No.		
M24	39	38	Approx. 54 – 66

Is the measurement value within the specification?

- YES >> GO TO 3.
NO >> Repair the combination meter branch line.

3. CHECK POWER SUPPLY AND GROUND CIRCUIT

Check the power supply and the ground circuit of the combination meter. Refer to [MWI-59, "COMBINATION METER : Diagnosis Procedure"](#).

Is the inspection result normal?

- YES (Present error)>>Replace the combination meter. Refer to [MWI-82, "Removal and Installation"](#).
YES (Past error)>>Error was detected in the combination meter branch line.
NO >> Repair the power supply and the ground circuit.

SONAR BRANCH LINE CIRCUIT

< DTC/CIRCUIT DIAGNOSIS >

[CAN]

SONAR BRANCH LINE CIRCUIT

Diagnosis Procedure

INFOID:000000008510129

1. CHECK CONNECTOR

1. Turn the ignition switch OFF.
2. Disconnect the battery cable from the negative terminal.
3. Check the terminals and connectors of sonar control unit for damage, bend and loose connection (unit side and connector side).

Is the inspection result normal?

- YES >> GO TO 2.
NO >> Repair the terminal and connector.

2. CHECK HARNESS FOR OPEN CIRCUIT

1. Disconnect the connector of sonar control unit.
2. Check the resistance between the sonar control unit harness connector terminals.

Sonar control unit harness connector			Resistance (Ω)
Connector No.	Terminal No.		
M70	5	6	Approx. 54 – 66

Is the measurement value within the specification?

- YES >> GO TO 3.
NO >> Replace the main harness.

3. CHECK POWER SUPPLY AND GROUND CIRCUIT

Check the power supply and the ground circuit of the sonar control unit. Refer to [SN-32, "Diagnosis Procedure"](#).

Is the inspection result normal?

- YES (Present error)>>Replace the sonar control unit. Refer to [SN-34, "Removal and Installation"](#).
YES (Past error)>>Error was detected in the sonar control unit branch line.
NO >> Repair the power supply and the ground circuit.

A
B
C
D
E
F
G
H
I
J
K
L

LAN

STRG BRANCH LINE CIRCUIT

< DTC/CIRCUIT DIAGNOSIS >

[CAN]

STRG BRANCH LINE CIRCUIT

Diagnosis Procedure

INFOID:000000008510121

1. CHECK CONNECTOR

1. Turn the ignition switch OFF.
2. Disconnect the battery cable from the negative terminal.
3. Check the terminals and connectors of the steering angle sensor for damage, bend and loose connection (unit side and connector side).

Is the inspection result normal?

- YES >> GO TO 2.
NO >> Repair the terminal and connector.

2. CHECK HARNESS FOR OPEN CIRCUIT

1. Disconnect the connector of steering angle sensor.
2. Check the resistance between the steering angle sensor harness connector terminals.

Steering angle sensor harness connector			Resistance (Ω)
Connector No.	Terminal No.		
M54	5	2	Approx. 54 – 66

Is the measurement value within the specification?

- YES >> GO TO 3.
NO >> Repair the steering angle sensor branch line.

3. CHECK POWER SUPPLY AND GROUND CIRCUIT

Check the power supply and the ground circuit of the steering angle sensor. Refer to [BRC-44, "Wiring Diagram"](#).

Is the inspection result normal?

- YES (Present error)>>Replace the steering angle sensor. Refer to [BRC-124, "Removal and Installation"](#).
YES (Past error)>>Error was detected in the steering angle sensor branch line.
NO >> Repair the power supply and the ground circuit.

ADP BRANCH LINE CIRCUIT

< DTC/CIRCUIT DIAGNOSIS >

[CAN]

ADP BRANCH LINE CIRCUIT

Diagnosis Procedure

INFOID:000000008510130

1. CHECK CONNECTOR

1. Turn the ignition switch OFF.
2. Disconnect the battery cable from the negative terminal.
3. Check the following terminals and connectors for damage, bend and loose connection (unit side and connector side).
 - Driver seat control unit
 - Harness connector B200
 - Harness connector B54
 - CAN gateway (Models with around view monitor)

Is the inspection result normal?

- YES-1 >> Models with around view monitor: GO TO 2.
YES-2 >> Models without around view monitor: GO TO 3.
NO >> Repair the terminal and connector.

2. CHECK HARNESS CONTINUITY (OPEN CIRCUIT)

1. Disconnect the connector of CAN gateway.
2. Check the continuity between the CAN gateway harness connector terminals.

CAN gateway harness connector			Continuity
Connector No.	Terminal No.		
M5	4	6	Existed
	10	12	Existed

Is the inspection result normal?

- YES >> GO TO 3.
NO >> Check the harness and repair the root cause (CAN communication circuit 2 side).

3. CHECK HARNESS FOR OPEN CIRCUIT

1. Connect the connector of CAN gateway. (Models with around view monitor)
2. Disconnect the connector of driver seat control unit.
3. Check the resistance between the driver seat control unit harness connector terminals.

Driver seat control unit harness connector			Resistance (Ω)
Connector No.	Terminal No.		
B209	16	32	Approx. 54 – 66

Is the measurement value within the specification?

- YES >> GO TO 4.
NO >> Repair the driver seat control unit branch line.

4. CHECK POWER SUPPLY AND GROUND CIRCUIT

Check the power supply and the ground circuit of the driver seat control unit. Refer to [ADP-83, "DRIVER SEAT CONTROL UNIT : Diagnosis Procedure"](#).

Is the inspection result normal?

- YES (Present error)>>Replace the driver seat control unit. Refer to [ADP-156, "Removal and Installation"](#).
YES (Past error)>>Error was detected in the driver seat control unit branch line.
NO >> Repair the power supply and the ground circuit.

A
B
C
D
E
F
G
H
I
J
K
L
N
O
P

LAN

4WD BRANCH LINE CIRCUIT

< DTC/CIRCUIT DIAGNOSIS >

[CAN]

4WD BRANCH LINE CIRCUIT

Diagnosis Procedure

INFOID:000000008510125

1. CHECK CONNECTOR

1. Turn the ignition switch OFF.
2. Disconnect the battery cable from the negative terminal.
3. Check the following terminals and connectors for damage, bend and loose connection (unit side and connector side).
 - 4WD control unit
 - CAN gateway (Models with around view monitor)

Is the inspection result normal?

- YES-1 >> Models with around view monitor: GO TO 2.
YES-2 >> Models without around view monitor: GO TO 3.
NO >> Repair the terminal and connector.

2. CHECK HARNESS CONTINUITY (OPEN CIRCUIT)

1. Disconnect the connector of CAN gateway.
2. Check the continuity between the CAN gateway harness connector terminals.

CAN gateway harness connector		Continuity	
Connector No.	Terminal No.		
M5	4	6	Existed
	10	12	Existed

Is the inspection result normal?

- YES >> GO TO 3.
NO >> Check the harness and repair the root cause (CAN communication circuit 2 side).

3. CHECK HARNESS FOR OPEN CIRCUIT

1. Connect the connector of CAN gateway. (Models with around view monitor)
2. Disconnect the connector of 4WD control unit.
3. Check the resistance between the 4WD control unit harness connector terminals.

4WD control unit harness connector		Resistance (Ω)	
Connector No.	Terminal No.		
B67	8	16	Approx. 54 – 66

Is the measurement value within the specification?

- YES >> GO TO 4.
NO >> Repair the 4WD control unit branch line.

4. CHECK POWER SUPPLY AND GROUND CIRCUIT

Check the power supply and the ground circuit of the 4WD control unit. Refer to [DLN-59, "Diagnosis Procedure"](#).

Is the inspection result normal?

- YES (Present error)>>Replace the 4WD control unit. Refer to [DLN-71, "Removal and Installation"](#).
YES (Past error)>>Error was detected in the 4WD control unit branch line.
NO >> Repair the power supply and the ground circuit.

PWBD BRANCH LINE CIRCUIT

< DTC/CIRCUIT DIAGNOSIS >

[CAN]

PWBD BRANCH LINE CIRCUIT

Diagnosis Procedure

INFOID:000000008510126

1. CHECK CONNECTOR

1. Turn the ignition switch OFF.
2. Disconnect the battery cable from the negative terminal.
3. Check the following terminals and connectors for damage, bend and loose connection (unit side and connector side).
 - Automatic back door control module
 - CAN gateway (Models with around view monitor)

Is the inspection result normal?

- YES-1 >> Models with around view monitor: GO TO 2.
YES-2 >> Models without around view monitor: GO TO 3.
NO >> Repair the terminal and connector.

2. CHECK HARNESS CONTINUITY (OPEN CIRCUIT)

1. Disconnect the connector of CAN gateway.
2. Check the continuity between the CAN gateway harness connector terminals.

CAN gateway harness connector		Continuity	
Connector No.	Terminal No.		
M5	4	6	Existed
	10	12	Existed

Is the inspection result normal?

- YES >> GO TO 3.
NO >> Check the harness and repair the root cause (CAN communication circuit 2 side).

3. CHECK HARNESS FOR OPEN CIRCUIT

1. Connect the connector of CAN gateway. (Models with around view monitor)
2. Disconnect the connector of automatic back door control module.
3. Check the resistance between the automatic back door control module harness connector terminals.

Automatic back door control module harness connector		Resistance (Ω)	
Connector No.	Terminal No.		
B55	24	12	Approx. 54 – 66

Is the measurement value within the specification?

- YES >> GO TO 4.
NO >> Replace the body harness.

4. CHECK POWER SUPPLY AND GROUND CIRCUIT

Check the power supply and the ground circuit of the automatic back door control module. Refer to [DLK-160, "AUTOMATIC BACK DOOR CONTROL UNIT : Diagnosis Procedure"](#).

Is the inspection result normal?

- YES (Present error)>>Replace the automatic back door control module. Refer to [DLK-317, "Removal and Installation"](#).
YES (Past error)>>Error was detected in the automatic back door control module branch line.
NO >> Repair the power supply and the ground circuit.

A
B
C
D
E
F
G
H
I
J
K
L
N
O
P

LAN

BCM BRANCH LINE CIRCUIT

[CAN]

< DTC/CIRCUIT DIAGNOSIS >

BCM BRANCH LINE CIRCUIT

Diagnosis Procedure

INFOID:000000008510127

1. CHECK CONNECTOR

1. Turn the ignition switch OFF.
2. Disconnect the battery cable from the negative terminal.
3. Check the following terminals and connectors for damage, bend and loose connection (unit side and connector side).
 - BCM
 - Harness connector M84 (Models without around view monitor)
 - Harness connector B101 (Models without around view monitor)
 - Harness connector B124 (Models without around view monitor)
 - Harness connector B32 (Models without around view monitor)
 - Harness connector B69 (2WD models without automatic back door system)
 - Harness connector M40 (2WD models without automatic back door system)

Is the inspection result normal?

YES >> GO TO 2.

NO >> Repair the terminal and connector.

2. CHECK HARNESS FOR OPEN CIRCUIT

1. Disconnect the connector of BCM.
2. Check the resistance between the BCM harness connector terminals.

BCM harness connector			Resistance (Ω)
Connector No.	Terminal No.		
M19	60	59	Approx. 108 – 132

Is the measurement value within the specification?

YES >> GO TO 3.

NO >> Repair the BCM branch line.

3. CHECK POWER SUPPLY AND GROUND CIRCUIT

Check the power supply and the ground circuit of the BCM. Refer to [BCS-72, "Diagnosis Procedure"](#).

Is the inspection result normal?

YES (Present error)>>Replace the BCM. Refer to [BCS-78, "Removal and Installation"](#).

YES (Past error)>>Error was detected in the BCM branch line.

NO >> Repair the power supply and the ground circuit.

CGW BRANCH LINE CIRCUIT (CAN COMMUNICATION CIRCUIT 1)

[CAN]

< DTC/CIRCUIT DIAGNOSIS >

CGW BRANCH LINE CIRCUIT (CAN COMMUNICATION CIRCUIT 1)

Diagnosis Procedure

INFOID:000000008510123

1. CHECK DTC

Check DTC of the CAN gateway with CONSULT.

Is U1010 or B2600 indicated?

- YES >> Perform a diagnosis of the indicated DTC.
- NO >> GO TO 2.

2. CHECK CONNECTOR

1. Turn the ignition switch OFF.
2. Disconnect the battery cable from the negative terminal.
3. Check the terminals and connectors of the CAN gateway for damage, bend and loose connection (unit side and connector side).

Is the inspection result normal?

- YES >> GO TO 3.
- NO >> Repair the terminal and connector.

3. CHECK HARNESS FOR OPEN CIRCUIT

1. Disconnect the connector of CAN gateway.
2. Check the resistance between the CAN gateway harness connector terminals.

CAN gateway harness connector			Resistance (Ω)
Connector No.	Terminal No.		
M5	1	7	Approx. 54 – 66

Is the measurement value within the specification?

- YES >> GO TO 4.
- NO >> Repair the CAN gateway branch line (CAN communication circuit 1 side).

4. CHECK POWER SUPPLY AND GROUND CIRCUIT

Check the power supply and the ground circuit of the CAN gateway. Refer to [LAN-107. "Diagnosis Procedure"](#).

Is the inspection result normal?

- YES (Present error)>>Replace the CAN gateway. Refer to [LAN-108. "Removal and Installation"](#).
- YES (Past error)>>Error was detected in the CAN gateway branch line (CAN communication circuit 1 side).
- NO >> Repair the power supply and the ground circuit.

A
B
C
D
E
F
G
H
I
J
K
L

LAN

CGW BRANCH LINE CIRCUIT (CAN COMMUNICATION CIRCUIT 2)

< DTC/CIRCUIT DIAGNOSIS >

[CAN]

CGW BRANCH LINE CIRCUIT (CAN COMMUNICATION CIRCUIT 2)

Diagnosis Procedure

INFOID:000000008510124

1. CHECK DTC

Check DTC of the CAN gateway with CONSULT.

Is U1010 or B2600 indicated?

- YES >> Perform a diagnosis of the indicated DTC.
- NO >> GO TO 2.

2. CHECK CONNECTOR

1. Turn the ignition switch OFF.
2. Disconnect the battery cable from the negative terminal.
3. Check the following terminals and connectors of the CAN gateway for damage, bend and loose connection (unit side and connector side).

Is the inspection result normal?

- YES >> GO TO 3.
- NO >> Repair the terminal and connector.

3. CHECK HARNESS CONTINUITY (OPEN CIRCUIT)

1. Disconnect the connector of CAN gateway.
2. Check the continuity between the CAN gateway harness connector terminals.

CAN gateway harness connector			Continuity
Connector No.	Terminal No.		
M5	4	6	Existed
	10	12	Existed

Is the inspection result normal?

- YES >> GO TO 4.
- NO >> Repair the CAN gateway branch line (CAN communication circuit 2 side).

4. CHECK POWER SUPPLY AND GROUND CIRCUIT

Check the power supply and the ground circuit of the CAN gateway. Refer to [LAN-107, "Diagnosis Procedure"](#).

Is the inspection result normal?

- YES (Present error)>>Replace the CAN gateway. Refer to [LAN-108, "Removal and Installation"](#).
- YES (Past error)>>Error was detected in the CAN gateway branch line (CAN communication circuit 2 side).
- NO >> Repair the power supply and the ground circuit.

AVM BRANCH LINE CIRCUIT

< DTC/CIRCUIT DIAGNOSIS >

[CAN]

AVM BRANCH LINE CIRCUIT

Diagnosis Procedure

INFOID:000000008510128

1. CHECK CONNECTOR

1. Turn the ignition switch OFF.
2. Disconnect the battery cable from the negative terminal.
3. Check the following terminals and connectors for damage, bend and loose connection (unit side and connector side).
 - Around view monitor control unit
 - CAN gateway

Is the inspection result normal?

- YES >> GO TO 2.
NO >> Repair the terminal and connector.

2. CHECK HARNESS CONTINUITY (OPEN CIRCUIT)

1. Disconnect the connector of CAN gateway.
2. Check the continuity between the CAN gateway harness connector terminals.

CAN gateway harness connector		Continuity	
Connector No.	Terminal No.		
M5	4	6	Existed
	10	12	Existed

Is the inspection result normal?

- YES >> GO TO 3.
NO >> Check the harness and repair the root cause (CAN communication circuit 2 side).

3. CHECK HARNESS FOR OPEN CIRCUIT

1. Connect the connector of CAN gateway.
2. Disconnect the connector of around view monitor control unit.
3. Check the resistance between the around view monitor control unit harness connector terminals.

Around view monitor control unit harness connector		Resistance (Ω)	
Connector No.	Terminal No.		
M96	12	10	Approx. 54 – 66

Is the measurement value within the specification?

- YES >> GO TO 4.
NO >> Replace the main harness.

4. CHECK POWER SUPPLY AND GROUND CIRCUIT

Check the power supply and the ground circuit of the around view monitor control unit. Refer to [AV-537, "AROUND VIEW MONITOR CONTROL UNIT : Diagnosis Procedure"](#).

Is the inspection result normal?

- YES (Present error)>>Replace the around view monitor control unit. Refer to [AV-603, "Removal and Installation"](#).
YES (Past error)>>Error was detected in the around view monitor control unit branch line.
NO >> Repair the power supply and the ground circuit.

A
B
C
D
E
F
G
H
I
J
K
L
LAN
N
O
P

CAN COMMUNICATION CIRCUIT

< DTC/CIRCUIT DIAGNOSIS >

[CAN]

CAN COMMUNICATION CIRCUIT

Diagnosis Procedure

INFOID:000000008510138

1.CONNECTOR INSPECTION

1. Turn the ignition switch OFF.
2. Disconnect the battery cable from the negative terminal.
3. Disconnect all the unit connectors on CAN communication circuit.
4. Check terminals and connectors for damage, bend and loose connection.

Is the inspection result normal?

- YES >> GO TO 2.
NO >> Repair the terminal and connector.

2.CHECK HARNESS CONTINUITY (SHORT CIRCUIT)

Check the continuity between the data link connector terminals.

Data link connector			Continuity
Connector No.	Terminal No.		
M22	6	14	Not existed

Is the inspection result normal?

- YES >> GO TO 3.
NO >> Check the harness and repair the root cause.

3.CHECK HARNESS CONTINUITY (SHORT CIRCUIT)

Check the continuity between the data link connector and the ground.

Data link connector		Ground	Continuity
Connector No.	Terminal No.		
M22	6		Not existed
	14		Not existed

Is the inspection result normal?

- YES >> GO TO 4.
NO >> Check the harness and repair the root cause.

4.CHECK ECM AND BCM TERMINATION CIRCUIT

1. Remove the ECM and the BCM.
2. Check the resistance between the ECM terminals.

ECM		Resistance (Ω)
Terminal No.		
114	113	Approx. 108 – 132

3. Check the resistance between the BCM terminals.

BCM		Resistance (Ω)
Terminal No.		
60	59	Approx. 108 – 132

Is the measurement value within the specification?

- YES >> GO TO 5.
NO >> Replace the ECM and/or the BCM.

5.CHECK SYMPTOM

Connect all the connectors. Check if the symptoms described in the “Symptom (Results from interview with customer)” are reproduced.

CAN COMMUNICATION CIRCUIT

[CAN]

< DTC/CIRCUIT DIAGNOSIS >

Inspection result

Reproduced>>GO TO 6.

Non-reproduced>>Start the diagnosis again. Follow the trouble diagnosis procedure when past error is detected.

6.CHECK UNIT REPRODUCTION

Perform the reproduction test as per the following procedure for each unit.

1. Turn the ignition switch OFF.
2. Disconnect the battery cable from the negative terminal.
3. Disconnect one of the unit connectors of CAN communication circuit.

NOTE:

ECM and BCM have a termination circuit. Check other units first.

4. Connect the battery cable to the negative terminal. Check if the symptoms described in the “Symptom (Results from interview with customer)” are reproduced.

NOTE:

Although unit-related error symptoms occur, do not confuse them with other symptoms.

Inspection result

Reproduced>>Connect the connector. Check other units as per the above procedure.

Non-reproduced>>Replace the unit whose connector was disconnected.

A
B
C
D
E
F
G
H
I
J
K
L

LAN

N
O
P

CAN COMMUNICATION CIRCUIT 1

< DTC/CIRCUIT DIAGNOSIS >

[CAN]

CAN COMMUNICATION CIRCUIT 1

Diagnosis Procedure

INFOID:000000008510139

1.CONNECTOR INSPECTION

1. Turn the ignition switch OFF.
2. Disconnect the battery cable from the negative terminal.
3. Disconnect all the unit connectors on CAN communication circuit 1.
4. Check terminals and connectors for damage, bend and loose connection.

Is the inspection result normal?

- YES >> GO TO 2.
NO >> Repair the terminal and connector.

2.CHECK HARNESS CONTINUITY (SHORT CIRCUIT)

Check the continuity between the data link connector terminals.

Data link connector			Continuity
Connector No.	Terminal No.		
M22	6	14	Not existed

Is the inspection result normal?

- YES >> GO TO 3.
NO >> Check the harness and repair the root cause.

3.CHECK HARNESS CONTINUITY (SHORT CIRCUIT)

Check the continuity between the data link connector and the ground.

Data link connector		Ground	Continuity
Connector No.	Terminal No.		
M22	6		Not existed
	14		Not existed

Is the inspection result normal?

- YES >> GO TO 4.
NO >> Check the harness and repair the root cause.

4.CHECK ECM AND BCM TERMINATION CIRCUIT

1. Remove the ECM and the BCM.
2. Check the resistance between the ECM terminals.

ECM		Resistance (Ω)
Terminal No.		
114	113	Approx. 108 – 132

3. Check the resistance between the BCM terminals.

BCM		Resistance (Ω)
Terminal No.		
60	59	Approx. 108 – 132

Is the measurement value within the specification?

- YES >> GO TO 5.
NO >> Replace the ECM and/or the BCM.

5.CHECK SYMPTOM

Connect all the connectors. Check if the symptoms described in the “Symptom (Results from interview with customer)” are reproduced.

CAN COMMUNICATION CIRCUIT 1

[CAN]

< DTC/CIRCUIT DIAGNOSIS >

Inspection result

Reproduced>>GO TO 6.

Non-reproduced>>Start the diagnosis again. Follow the trouble diagnosis procedure when past error is detected.

6.CHECK UNIT REPRODUCTION

Perform the reproduction test as per the following procedure for each unit.

1. Turn the ignition switch OFF.
2. Disconnect the battery cable from the negative terminal.
3. Disconnect one of the unit connectors of CAN communication circuit 1.

NOTE:

ECM and BCM have a termination circuit. Check other units first.

4. Connect the battery cable to the negative terminal. Check if the symptoms described in the “Symptom (Results from interview with customer)” are reproduced.

NOTE:

Although unit-related error symptoms occur, do not confuse them with other symptoms.

Inspection result

Reproduced>>Connect the connector. Check other units as per the above procedure.

Non-reproduced>>Replace the unit whose connector was disconnected.

A
B
C
D
E
F
G
H
I
J
K
L

LAN

N
O
P

CAN COMMUNICATION CIRCUIT 2

< DTC/CIRCUIT DIAGNOSIS >

[CAN]

CAN COMMUNICATION CIRCUIT 2

Diagnosis Procedure

INFOID:000000008510140

1.CONNECTOR INSPECTION

1. Turn the ignition switch OFF.
2. Disconnect the battery cable from the negative terminal.
3. Disconnect all the unit connectors on CAN communication circuit 2.
4. Check terminals and connectors for damage, bend and loose connection.

Is the inspection result normal?

- YES >> GO TO 2.
NO >> Repair the terminal and connector.

2.CHECK HARNESS CONTINUITY (SHORT CIRCUIT)

Check the continuity between the data link connector terminals.

Data link connector		Continuity
Connector No.	Terminal No.	
M22	13	Not existed
	12	

Is the inspection result normal?

- YES >> GO TO 3.
NO >> Check the harness and repair the root cause.

3.CHECK HARNESS CONTINUITY (SHORT CIRCUIT)

Check the continuity between the data link connector and the ground.

Data link connector		Ground	Continuity
Connector No.	Terminal No.		
M22	13		Not existed
	12		Not existed

Is the inspection result normal?

- YES >> GO TO 4.
NO >> Check the harness and repair the root cause.

4.CHECK CAN GATEWAY TERMINATION CIRCUIT

1. Remove the CAN gateway.
2. Check the resistance between the CAN gateway terminals.

CAN gateway		Resistance (Ω)
Terminal No.		
4	10	Approx. 108 – 132
6	12	Approx. 108 – 132

Is the measurement value within the specification?

- YES >> GO TO 5.
NO >> Replace the CAN gateway.

5.CHECK SYMPTOM

Connect all the connectors. Check if the symptoms described in the “Symptom (Results from interview with customer)” are reproduced.

Inspection result

- Reproduced>>GO TO 6.
Non-reproduced>>Start the diagnosis again. Follow the trouble diagnosis procedure when past error is detected.

CAN COMMUNICATION CIRCUIT 2

< DTC/CIRCUIT DIAGNOSIS >

[CAN]

6. CHECK UNIT REPRODUCTION

Perform the reproduction test as per the following procedure for each unit.

1. Turn the ignition switch OFF.
2. Disconnect the battery cable from the negative terminal.
3. Disconnect one of the unit connectors of CAN communication circuit 2.

NOTE:

CAN gateway has two termination circuits. Check other units first.

4. Connect the battery cable to the negative terminal. Check if the symptoms described in the "Symptom (Results from interview with customer)" are reproduced.

NOTE:

Although unit-related error symptoms occur, do not confuse them with other symptoms.

Inspection result

Reproduced>>Connect the connector. Check other units as per the above procedure.

Non-reproduced>>Replace the unit whose connector was disconnected.

A
B
C
D
E
F
G
H
I
J
K
L

LAN

N
O
P

PRECAUTION

PRECAUTIONS

Precaution for Supplemental Restraint System (SRS) "AIR BAG" and "SEAT BELT PRE-TENSIONER"

INFOID:000000009002457

The Supplemental Restraint System such as "AIR BAG" and "SEAT BELT PRE-TENSIONER", used along with a front seat belt, helps to reduce the risk or severity of injury to the driver and front passenger for certain types of collision. This system includes seat belt switch inputs and dual stage front air bag modules. The SRS system uses the seat belt switches to determine the front air bag deployment, and may only deploy one front air bag, depending on the severity of a collision and whether the front occupants are belted or unbelted. Information necessary to service the system safely is included in the SR and SB section of this Service Manual.

WARNING:

- To avoid rendering the SRS inoperative, which could increase the risk of personal injury or death in the event of a collision which would result in air bag inflation, all maintenance must be performed by an authorized NISSAN/INFINITI dealer.
- Improper maintenance, including incorrect removal and installation of the SRS, can lead to personal injury caused by unintentional activation of the system. For removal of Spiral Cable and Air Bag Module, see the SR section.
- Do not use electrical test equipment on any circuit related to the SRS unless instructed to in this Service Manual. SRS wiring harnesses can be identified by yellow and/or orange harnesses or harness connectors.

PRECAUTIONS WHEN USING POWER TOOLS (AIR OR ELECTRIC) AND HAMMERS

WARNING:

- When working near the Airbag Diagnosis Sensor Unit or other Airbag System sensors with the Ignition ON or engine running, DO NOT use air or electric power tools or strike near the sensor(s) with a hammer. Heavy vibration could activate the sensor(s) and deploy the air bag(s), possibly causing serious injury.
- When using air or electric power tools or hammers, always switch the Ignition OFF, disconnect the battery and wait at least 3 minutes before performing any service.

SYSTEM DESCRIPTION

COMPONENT PARTS

Component Parts Location

INFOID:000000008510143

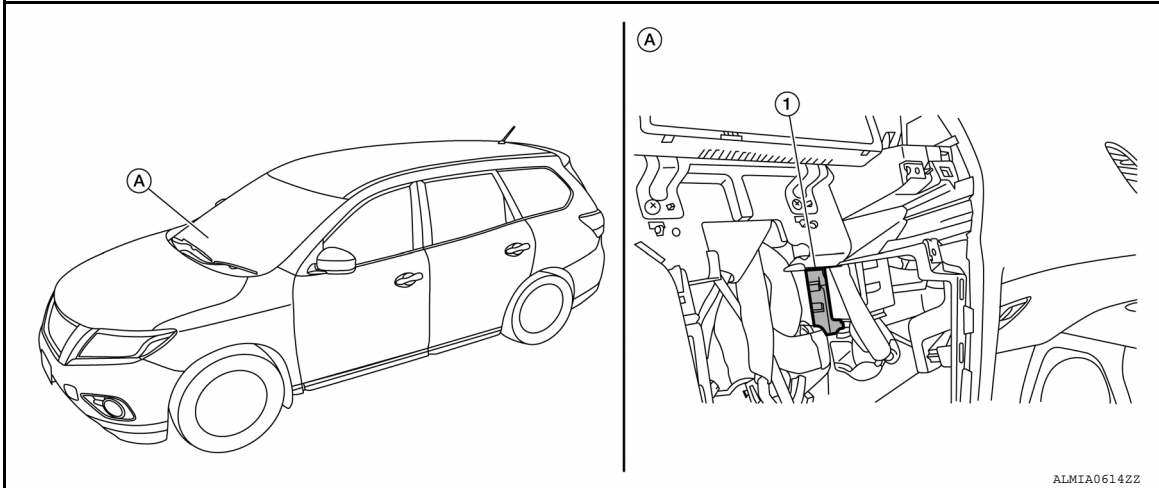

- ① CAN gateway
- Ⓐ Left side of glove box

A
B
C
D
E
F
G
H
I
J
K
L

LAN

N
O
P

SYSTEM

< SYSTEM DESCRIPTION >

[CAN GATEWAY]

SYSTEM

System Description

INFOID:000000008510144

SYSTEM DIAGRAM

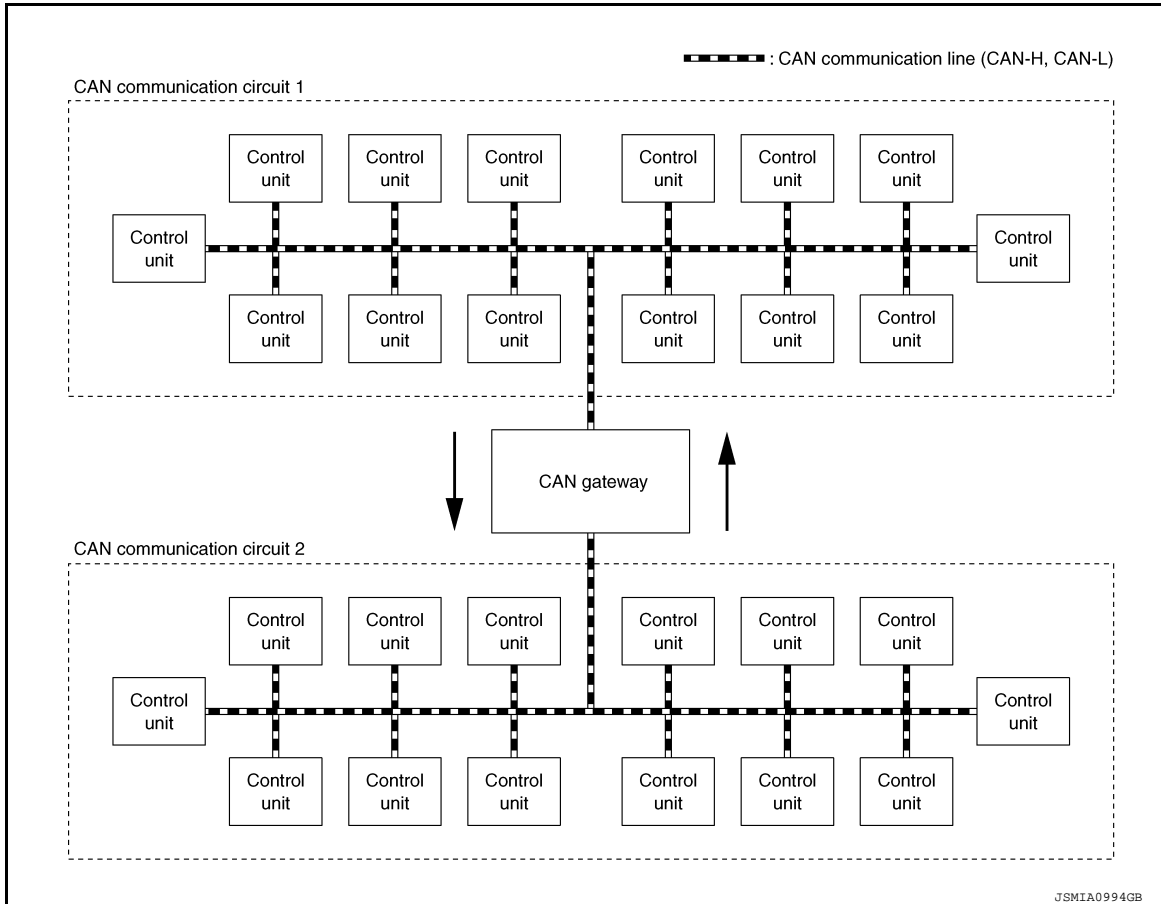

SYSTEM DESCRIPTION

- The CAN gateway system communicates between two CAN communication circuits.
- This system selects and transmits only necessary information.

DIAGNOSIS SYSTEM (CAN GATEWAY)

< SYSTEM DESCRIPTION >

[CAN GATEWAY]

DIAGNOSIS SYSTEM (CAN GATEWAY)

CONSULT Function

INFOID:000000008510145

APPLICATION ITEM

CONSULT performs the following functions via CAN communication with CAN gateway.

Diagnosis mode	Function Description
Ecu Identification	The CAN gateway part number is displayed.
Self Diagnostic Result	Displays the diagnosis results judged by CAN gateway.
CAN Diag Support Monitor	The results of transmit/receive diagnosis of CAN communication can be read.
Configuration	<ul style="list-style-type: none">• Read and save the vehicle specification.• Write the vehicle specification when replacing CAN gateway.

ECU IDENTIFICATION

The CAN gateway part number is displayed.

SELF DIAGNOSTIC RESULT

Refer to [LAN-99. "DTC Index"](#).

- When "CRNT" is displayed on self-diagnosis result
 - The system is presently malfunctioning.
- When "PAST" is displayed on self-diagnosis result
 - System malfunction in the past is detected, but the system is presently normal.

Freeze Frame Data (FFD)

When DTC is detected, a vehicle state shown below is recorded and displayed on CONSULT.

Item name	Display item
IGN counter (0 – 39)	<p>The number of times that ignition switch is turned ON after the DTC is detected is displayed.</p> <ul style="list-style-type: none">• When "0" is displayed: It indicates that the system is presently malfunctioning.• When except "0" is displayed: It indicates that system malfunction in the past is detected, but the system is presently normal. <p>NOTE: Each time when ignition switch is turned OFF to ON, numerical number increases in 1 → 2 → 3...38 → 39. When the operation number of times exceeds 39, the number do not increase and "39" is displayed until self-diagnosis result is erased.</p>

CAN DIAG SUPPORT MONITOR

The results of transmit/receive diagnosis of CAN communication can be read.

CONFIGURATION

Function	Description
Read / Write Configuration	Before Replace ECU <ul style="list-style-type: none">• Reads the vehicle configuration of current CAN gateway.• Saves the read vehicle configuration.
	After Replace ECU <ul style="list-style-type: none">• Writes the vehicle configuration with saved data.
Manual Configuration	Writes the vehicle configuration with manual selection.

CAUTION:

Follow the instructions listed below. Failure to do this may cause malfunctions to the CAN gateway.:

- When replacing CAN gateway, you must perform "Read / Write Configuration" or "Manual Configuration" with CONSULT.
- Complete the procedure of "Read / Write Configuration" or "Manual Configuration" in order.
- If you set incorrect "Read / Write Configuration" or "Manual Configuration", incidents might occur.
- Configuration is different for each vehicle model. Confirm configuration of each vehicle model.
- Never perform "Read / Write Configuration" or "Manual Configuration" except for new CAN gateway.

CAN GATEWAY

< ECU DIAGNOSIS INFORMATION >

[CAN GATEWAY]

ECU DIAGNOSIS INFORMATION

CAN GATEWAY

Reference Value

INFOID:000000008510146

TERMINAL LAYOUT

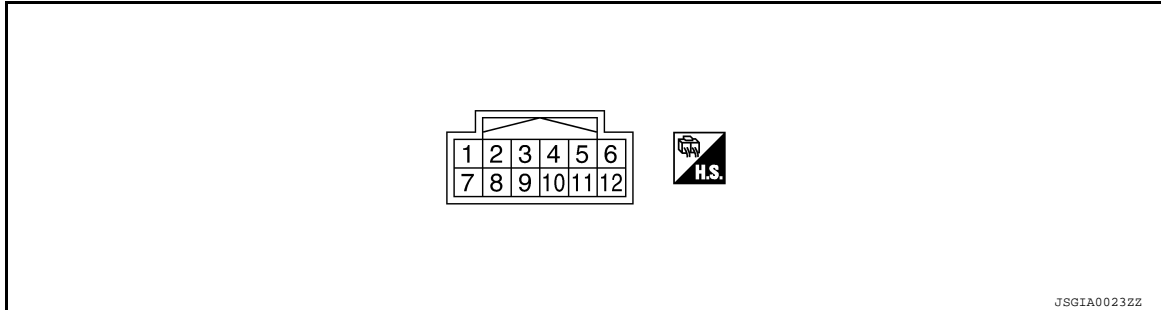

PHYSICAL VALUES

Terminal No. (Wire color)		Description		Condition	Standard value	Reference value (Approx.)
+	-	Signal name	Input/ Output			
1 (L)	—	CAN-H (CAN communication circuit 1)	Input/ Output	—	—	—
3 (BG)	Ground	Battery power supply	Input	Ignition switch OFF	6 - 16 V	Battery voltage
4 (L)	—	CAN-H (CAN communication circuit 2)	Input/ Output	—	—	—
5 (B)	Ground	Ground	—	Ignition switch ON	—	0 V
6 (L)	—	CAN-H (CAN communication circuit 2)	Input/ Output	—	—	—
7 (P)	—	CAN-L (CAN communication circuit 1)	Input/ Output	—	—	—
9 (BG)	Ground	Ignition power supply	Input	Ignition switch ON	4.5 V - 16 V	Battery voltage
10 (P)	—	CAN-L (CAN communication circuit 2)	Input/ Output	—	—	—
11 (B)	Ground	Ground	—	Ignition switch ON	—	0 V
12 (P)	—	CAN-L (CAN communication circuit 2)	Input/ Output	—	—	—

DTC Inspection Priority Chart

INFOID:000000008510147

If some DTCs are displayed at the same time, perform inspections one by one based on the following priority chart.

Priority	DTC
1	<ul style="list-style-type: none"> B2600: CONFIG ERROR U1010: CONTROL UNIT(CAN)
2	U1000: CAN COMM CIRCUIT

CAN GATEWAY

< ECU DIAGNOSIS INFORMATION >

[CAN GATEWAY]

DTC Index

INFOID:000000008510148

DTC		Reference
No DTC is detected. Further testing may be required.		—
U1000: CAN COMM CIRCUIT		LAN-104
U1010: CONTROL UNIT(CAN)		LAN-105
B2600: CONFIG ERROR	WRONG DATA	LAN-106
	NOT CONFIGURED	

A
B
C
D
E
F
G
H
I
J
K
L
N
O
P

LAN

WIRING DIAGRAM

CAN GATEWAY SYSTEM

Wiring Diagram

INFOID:000000008510149

CAN GATEWAY SYSTEM

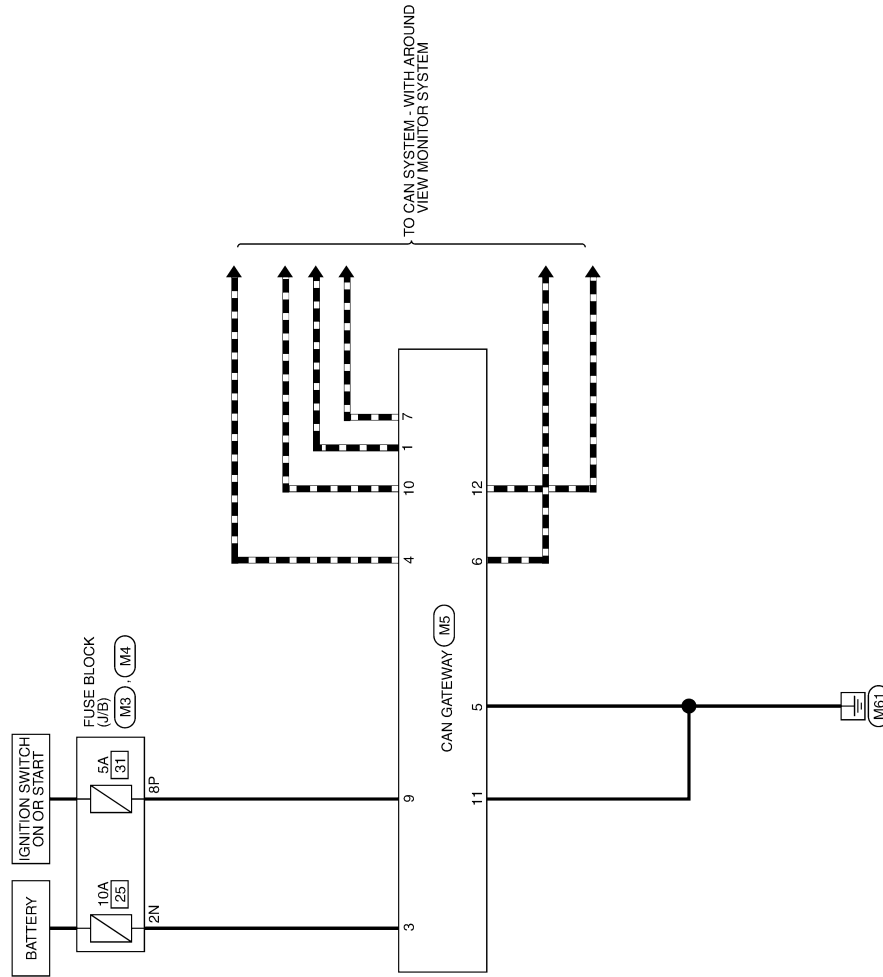

AAMWA0646GB

CAN GATEWAY SYSTEM

< WIRING DIAGRAM >

[CAN GATEWAY]

CAN GATEWAY SYSTEM CONNECTORS

Connector No.	M3
Connector Name	FUSE BLOCK (J/B)
Connector Color	WHITE

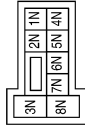

Terminal No.	Color of Wire	Signal Name
2N	BG	-

Connector No.	M4
Connector Name	FUSE BLOCK (J/B)
Connector Color	WHITE



Terminal No.	Color of Wire	Signal Name
8P	BG	-

Connector No.	M5
Connector Name	CAN GATEWAY
Connector Color	WHITE

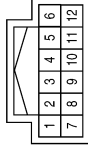

Terminal No.	Color of Wire	Signal Name
1	L	CAN-H
2	-	-
3	BG	BATTERY
4	L	CAN-H
5	B	GND
6	L	CAN-H
7	P	CAN-L
8	-	-
9	BG	IGNITION
10	P	CAN-L
11	B	GND
12	P	CAN-L

A
B
C
D
E
F
G
H
I
J
K
L
N
O
P

LAN

BASIC INSPECTION

ADDITIONAL SERVICE WHEN REPLACING CAN GATEWAY

Description

INFOID:000000008510150

BEFORE REPLACEMENT

When replacing CAN gateway, save or print current vehicle specification with CONSULT configuration before replacement.

NOTE:

If “Before Replace ECU” of “Read / Write Configuration” can not be used, use the “Manual Configuration” after replacing CAN gateway.

AFTER REPLACEMENT

CAUTION:

Follow the instructions listed below. Failure to do this may cause malfunctions to the CAN gateway.:

- When replacing CAN gateway, you must perform “Read / Write Configuration” or “Manual Configuration” with CONSULT.
- Complete the procedure of “Read / Write Configuration” or “Manual Configuration” in order.
- If you set incorrect “Read / Write Configuration” or “Manual Configuration”, incidents might occur.
- Configuration is different for each vehicle model. Confirm configuration of each vehicle model.
- Never perform “Read / Write Configuration” or “Manual Configuration” except for new CAN gateway.

Work Procedure

INFOID:000000008510151

1. SAVING VEHICLE SPECIFICATION

ⓅCONSULT Configuration

Perform “Before Replace ECU” of “Read / Write Configuration” to save or print current vehicle specification. Refer to [LAN-102, "Description"](#).

NOTE:

If “Before Replace ECU” of “Read / Write Configuration” can not be used, use the “Manual Configuration” after replacing CAN gateway.

>> GO TO 2.

2. REPLACE CAN GATEWAY

Replace CAN gateway. Refer to [LAN-108, "Removal and Installation"](#).

>> GO TO 3.

3. WRITING VEHICLE SPECIFICATION

ⓅCONSULT Configuration

Perform “After Replace ECU” of “Read / Write Configuration” or “Manual Configuration” to write vehicle specification. Refer to [LAN-103, "Work Procedure"](#).

>> WORK END

CONFIGURATION (CAN GATEWAY)

< BASIC INSPECTION >

[CAN GATEWAY]

CONFIGURATION (CAN GATEWAY)

Work Procedure

INFOID:000000008510152

1. WRITING MODE SELECTION

 CONSULT Configuration
Select "Re/programming, Configuration" of CAN gateway.

When writing saved data>>GO TO 2.
When writing manually>>GO TO 3.

2. PERFORM "AFTER REPLACE ECU" OF "READ / WRITE CONFIGURATION"

 CONSULT Configuration
Perform "After Replace ECU" of "Read / Write Configuration".

>> GO TO 4.

3. PERFORM "MANUAL CONFIGURATION"

 CONSULT Configuration

1. Select "Manual Configuration".
2. Touch "Next".
3. Touch "OK".
4. Check that the configuration has been successfully written and touch "End".

>> GO TO 4.

4. CHECK ALL ECU SELF-DIAGNOSIS RESULTS

1. Erase all ECU self-diagnosis results using CONSULT.
2. Turn the ignition switch OFF.
3. Turn the ignition switch ON and wait for 2 seconds or more.
4. Check that all ECU self-diagnosis results have no DTC (e.g. U1000 and U1001) of CAN communication.

>> WORK END

A
B
C
D
E
F
G
H
I
J
K
L

LAN

N
O
P

DTC/CIRCUIT DIAGNOSIS

U1000 CAN COMM CIRCUIT

Description

INFOID:000000008510153

CAN (Controller Area Network) is a serial communication line for real time applications. It is an on-vehicle multiplex communication line with high data communication speed and excellent error detection ability. Modern vehicle is equipped with many electronic control unit, and each control unit shares information and links with other control units during operation (not independent). In CAN communication, control units are connected with two communication lines (CAN-H and CAN-L) allowing a high rate of information transmission with less wiring. Each control unit transmits/receives data but selectively reads required data only.

CAN Communication Signal Chart. Refer to [LAN-36, "CAN COMMUNICATION SYSTEM : CAN Communication Signal Chart"](#).

DTC Logic

INFOID:000000008510154

DTC DETECTION LOGIC

DTC	CONSULT display description	DTC Detection Condition	Possible cause
U1000	CAN COMM CIRCUIT	When CAN gateway cannot communicate CAN communication signal continuously for 2 seconds or more.	CAN communication system

Diagnosis Procedure

INFOID:000000008510155

1. PERFORM SELF DIAGNOSTIC

1. Turn the ignition switch ON and wait for 2 seconds or more.
2. Check "Self Diagnostic Result".

Is "U1000: CAN COMM CIRCUIT" displayed?

- YES >> Refer to [LAN-20, "Trouble Diagnosis Flow Chart"](#).
- NO >> Refer to [GI-49, "Intermittent Incident"](#).

U1010 CONTROL UNIT (CAN)

< DTC/CIRCUIT DIAGNOSIS >

[CAN GATEWAY]

U1010 CONTROL UNIT (CAN)

Description

INFOID:000000008510156

CAN (Controller Area Network) is a serial communication line for real time applications. It is an on-vehicle multiplex communication line with high data communication speed and excellent error detection ability. Modern vehicle is equipped with many electronic control unit, and each control unit shares information and links with other control units during operation (not independent). In CAN communication, control units are connected with two communication lines (CAN-H and CAN-L) allowing a high rate of information transmission with less wiring. Each control unit transmits/receives data but selectively reads required data only.

CAN Communication Signal Chart. Refer to [LAN-36. "CAN COMMUNICATION SYSTEM : CAN Communication Signal Chart"](#).

DTC Logic

INFOID:000000008510157

DTC DETECTION LOGIC

DTC	CONSULT display description	DTC Detection Condition	Possible cause
U1010	CONTROL UNIT(CAN)	When an error is detected during the initial diagnosis for CAN controller of CAN gateway.	CAN gateway

Diagnosis Procedure

INFOID:000000008510158

1. REPLACE CAN GATEWAY

When DTC "U1010: CONTROL UNIT(CAN)" is detected, replace CAN gateway.

>> Replace CAN gateway. Refer to [LAN-108. "Removal and Installation"](#).

A
B
C
D
E
F
G
H
I
J
K
L
N
O
P

LAN

B2600 CONFIG ERROR

< DTC/CIRCUIT DIAGNOSIS >

[CAN GATEWAY]

B2600 CONFIG ERROR

Description

INFOID:000000008510159

The CAN gateway requires initial settings to judge necessary information, according to a vehicle specification.

DTC Logic

INFOID:000000008510160

DTC DETECTION LOGIC

DTC	CONSULT display description	DTC Detection Condition	Probable cause
B2600	CONFIG ERROR WRONG DATA	When errors are detected in the configuration data stored in the CAN gateway.	CAN gateway
	CONFIG ERROR NOT CONFIGURED	When no data are stored in the CAN gateway.	

Diagnosis Procedure

INFOID:000000008510161

1. REPLACE CAN GATEWAY

When DTC "B2600: CONFIG ERROR" is detected, replace CAN gateway.

>> Replace CAN gateway. Refer to [LAN-108, "Removal and Installation"](#).

POWER SUPPLY AND GROUND CIRCUIT

< DTC/CIRCUIT DIAGNOSIS >

[CAN GATEWAY]

POWER SUPPLY AND GROUND CIRCUIT

Diagnosis Procedure

INFOID:000000008510162

1. CHECK FUSE

Check that the following fuse are not blown.

Signal name	Fuse No.
Battery power supply	25
Ignition power supply	31

Is the fuse fusing?

YES >> Replace the blown fuse after repairing the affected circuit if a fuse is blown.

NO >> GO TO 2.

2. CHECK POWER SUPPLY CIRCUIT

1. Turn the ignition switch OFF.
2. Disconnect the connector of CAN gateway.
3. Check voltage between CAN gateway harness connector and ground.

Terminals		Condition	Standard voltage	Reference voltage (Approx.)
(+)	(-)			
CAN gateway		Ignition switch		
Connector	Terminal			
M5	3	OFF	6 - 16 V	Battery voltage
	9	ON	4.5 - 16 V	Battery voltage

Is the measurement value normal?

YES >> GO TO 3.

NO >> Repair harness or connector.

3. CHECK GROUND CIRCUIT

Check continuity between CAN gateway harness connector and ground.

CAN gateway		Ground	Continuity
Connector	Terminal		
M5	5		Existed
	11		

Does continuity exist?

YES >> INSPECTION END

NO >> Repair harness or connector.

A
B
C
D
E
F
G
H
I
J
K
L
N
O
P

LAN

REMOVAL AND INSTALLATION

CAN GATEWAY

Removal and Installation

INFOID:000000008510163

CAUTION:

Before replacing CAN gateway, perform “Before Replace ECU” of “Read / Write Configuration” to save or print current vehicle specification. Refer to [LAN-102, "Description"](#).

REMOVAL

1. Remove the AV control unit. Refer to [AV-585, "Removal and Installation"](#).
2. Remove the screw (A) from the bracket of the automatic drive positioner control unit (1).

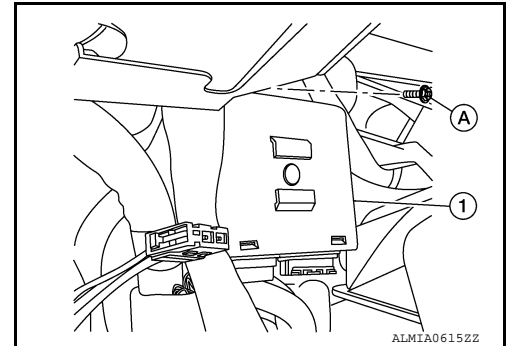

3. Position the automatic drive positioner control unit aside and remove the CAN gateway (2) from the bracket by sliding it as shown.

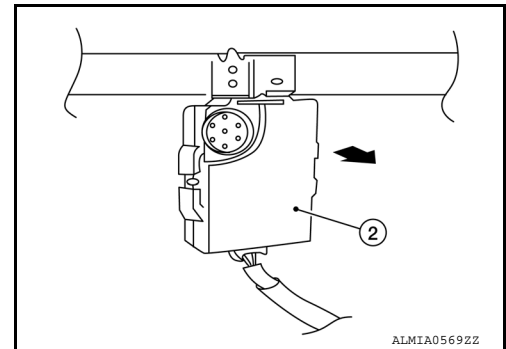

4. Disconnect the harness connector from the CAN gateway and remove the CAN gateway.

INSTALLATION

Installation is in the reverse order of removal.

CAUTION:

To prevent malfunction, be sure to perform “After Replace ECU” of “Read / Write Configuration” or “Manual Configuration” when replacing CAN gateway. Refer to [LAN-103, "Work Procedure"](#).

MAIN LINE BETWEEN IPDM-E AND ABS CIRCUIT

< DTC/CIRCUIT DIAGNOSIS >

[CAN SYSTEM (TYPE 1)]

DTC/CIRCUIT DIAGNOSIS

MAIN LINE BETWEEN IPDM-E AND ABS CIRCUIT

Diagnosis Procedure

INFOID:000000008970385

1. CHECK HARNESS CONTINUITY (OPEN CIRCUIT)

1. Turn the ignition switch OFF.
2. Disconnect the battery cable from the negative terminal.
3. Disconnect the following harness connectors.
 - ECM
 - IPDM E/R
 - ABS actuator and electric unit (control unit)
4. Check the continuity between the IPDM E/R harness connector and the ABS actuator and electric unit (control unit) harness connector.

IPDM E/R harness connector		ABS actuator and electric unit (control unit) harness connector		Continuity
Connector No.	Terminal No.	Connector No.	Terminal No.	
E119	29	E125	25	Existed
	28		15	Existed

Is the inspection result normal?

YES (Present error)>>Check CAN system type decision again.

YES (Past error)>>Error was detected in the main line between the IPDM E/R and the ABS actuator and electric unit (control unit).

NO >> Repair the main line between the IPDM E/R and the ABS actuator and electric unit (control unit).

A
B
C
D
E
F
G
H
I
J
K
L
N
O
P

LAN

MAIN LINE BETWEEN ABS AND DLC CIRCUIT

< DTC/CIRCUIT DIAGNOSIS >

[CAN SYSTEM (TYPE 1)]

MAIN LINE BETWEEN ABS AND DLC CIRCUIT

Diagnosis Procedure

INFOID:000000008970386

1.CHECK CONNECTOR

1. Turn the ignition switch OFF.
2. Disconnect the battery cable from the negative terminal.
3. Check the following terminals and connectors for damage, bend and loose connection (connector side and harness side).
 - Harness connector E152
 - Harness connector M31

Is the inspection result normal?

YES >> GO TO 2.

NO >> Repair the terminal and connector.

2.CHECK HARNESS CONTINUITY (OPEN CIRCUIT)

1. Disconnect the following harness connectors.
 - ABS actuator and electric unit (control unit)
 - Harness connectors E152 and M31.
2. Check the continuity between the ABS actuator and electric unit (control unit) harness connector and the harness connector.

ABS actuator and electric unit (control unit) harness connector		Harness connector		Continuity
Connector No.	Terminal No.	Connector No.	Terminal No.	
E125	25	E152	36G	Existed
	15		35G	Existed

Is the inspection result normal?

YES >> GO TO 3.

NO >> Repair the main line between the ABS actuator and electric unit (control unit) and the harness connector E152.

3.CHECK HARNESS CONTINUITY (OPEN CIRCUIT)

Check the continuity between the harness connector and the data link connector.

Harness connector		Data link connector		Continuity
Connector No.	Terminal No.	Connector No.	Terminal No.	
M31	36G	M22	6	Existed
	35G		14	Existed

Is the inspection result normal?

YES (Present error)>>Check CAN system type decision again.

YES (Past error)>>Error was detected in the main line between the ABS actuator and electric unit (control unit) and the data link connector.

NO >> Repair the main line between the harness connector M31 and the data link connector.

ECM BRANCH LINE CIRCUIT

< DTC/CIRCUIT DIAGNOSIS >

[CAN SYSTEM (TYPE 1)]

ECM BRANCH LINE CIRCUIT

Diagnosis Procedure

INFOID:000000008970393

1. CHECK CONNECTOR

1. Turn the ignition switch OFF.
2. Disconnect the battery cable from the negative terminal.
3. Check the terminals and connectors of the ECM for damage, bend and loose connection (unit side and connector side).

Is the inspection result normal?

- YES >> GO TO 2.
NO >> Repair the terminal and connector.

2. CHECK HARNESS FOR OPEN CIRCUIT

1. Disconnect the connector of ECM.
2. Check the resistance between the ECM harness connector terminals.

ECM harness connector			Resistance (Ω)
Connector No.	Terminal No.		
E16	114	113	Approx. 108 – 132

Is the measurement value within the specification?

- YES >> GO TO 3.
NO >> Repair the ECM branch line.

3. CHECK POWER SUPPLY AND GROUND CIRCUIT

Check the power supply and the ground circuit of the ECM. Refer to [EC-170. "Diagnosis Procedure"](#).

Is the inspection result normal?

- YES (Present error)>>Replace the ECM. Refer to [EC-460. "Removal and Installation"](#).
YES (Past error)>>Error was detected in the ECM branch line.
NO >> Repair the power supply and the ground circuit.

A
B
C
D
E
F
G
H
I
J
K
L

LAN

IPDM-E BRANCH LINE CIRCUIT

< DTC/CIRCUIT DIAGNOSIS >

[CAN SYSTEM (TYPE 1)]

IPDM-E BRANCH LINE CIRCUIT

Diagnosis Procedure

INFOID:000000008970394

1. CHECK CONNECTOR

1. Turn the ignition switch OFF.
2. Disconnect the battery cable from the negative terminal.
3. Check the terminals and connectors of the IPDM E/R for damage, bend and loose connection (unit side and connector side).

Is the inspection result normal?

- YES >> GO TO 2.
NO >> Repair the terminal and connector.

2. CHECK HARNESS FOR OPEN CIRCUIT

1. Disconnect the connector of IPDM E/R.
2. Check the resistance between the IPDM E/R harness connector terminals.

IPDM E/R harness connector			Resistance (Ω)
Connector No.	Terminal No.		
E119	29	28	Approx. 54 – 66

Is the measurement value within the specification?

- YES >> GO TO 3.
NO >> Repair the IPDM E/R branch line.

3. CHECK POWER SUPPLY AND GROUND CIRCUIT

Check the power supply and the ground circuit of the IPDM E/R. Refer to [PCS-31, "Diagnosis Procedure"](#).

Is the inspection result normal?

- YES (Present error)>>Replace the IPDM E/R. Refer to [PCS-32, "Removal and Installation"](#).
YES (Past error)>>Error was detected in the IPDM E/R branch line.
NO >> Repair the power supply and the ground circuit.

TCM BRANCH LINE CIRCUIT

< DTC/CIRCUIT DIAGNOSIS >

[CAN SYSTEM (TYPE 1)]

TCM BRANCH LINE CIRCUIT

Diagnosis Procedure

INFOID:000000008970395

1. CHECK CONNECTOR

1. Turn the ignition switch OFF.
2. Disconnect the battery cable from the negative terminal.
3. Check the following terminals and connectors for damage, bend and loose connection (unit side and connector side).
 - TCM
 - Harness connector F32
 - Harness connector E2

Is the inspection result normal?

- YES >> GO TO 2.
NO >> Repair the terminal and connector.

2. CHECK HARNESS FOR OPEN CIRCUIT

1. Disconnect the connector of TCM.
2. Check the resistance between the TCM harness connector terminals.

TCM harness connector		Resistance (Ω)
Connector No.	Terminal No.	
F15	33 23	Approx. 54 – 66

Is the measurement value within the specification?

- YES >> GO TO 3.
NO >> Repair the TCM branch line.

3. CHECK POWER SUPPLY AND GROUND CIRCUIT

Check the power supply and the ground circuit of the TCM. Refer to [TM-165, "Diagnosis Procedure"](#).

Is the inspection result normal?

- YES (Present error)>>Replace the TCM. Refer to [TM-197, "Removal and Installation"](#).
YES (Past error)>>Error was detected in the TCM branch line.
NO >> Repair the power supply and the ground circuit.

A
B
C
D
E
F
G
H
I
J
K
L

LAN

ABS BRANCH LINE CIRCUIT

< DTC/CIRCUIT DIAGNOSIS >

[CAN SYSTEM (TYPE 1)]

ABS BRANCH LINE CIRCUIT

Diagnosis Procedure

INFOID:000000008970396

1. CHECK CONNECTOR

1. Turn the ignition switch OFF.
2. Disconnect the battery cable from the negative terminal.
3. Check the terminals and connectors of the ABS actuator and electric unit (control unit) for damage, bend and loose connection (unit side and connector side).

Is the inspection result normal?

- YES >> GO TO 2.
NO >> Repair the terminal and connector.

2. CHECK HARNESS FOR OPEN CIRCUIT

1. Disconnect the connector of ABS actuator and electric unit (control unit).
2. Check the resistance between the ABS actuator and electric unit (control unit) harness connector terminals.

ABS actuator and electric unit (control unit) harness connector			Resistance (Ω)
Connector No.	Terminal No.		
E125	25	15	Approx. 54 – 66

Is the measurement value within the specification?

- YES >> GO TO 3.
NO >> Repair the ABS actuator and electric unit (control unit) branch line.

3. CHECK POWER SUPPLY AND GROUND CIRCUIT

Check the power supply and the ground circuit of the ABS actuator and electric unit (control unit). Refer to [BRC-63, "Diagnosis Procedure"](#).

Is the inspection result normal?

- YES (Present error)>>Replace the ABS actuator and electric unit (control unit). Refer to [BRC-121, "Removal and Installation"](#).
YES (Past error)>>Error was detected in the ABS actuator and electric unit (control unit) branch line.
NO >> Repair the power supply and the ground circuit.

EPS BRANCH LINE CIRCUIT

< DTC/CIRCUIT DIAGNOSIS >

[CAN SYSTEM (TYPE 1)]

EPS BRANCH LINE CIRCUIT

Diagnosis Procedure

INFOID:000000008970397

1. CHECK CONNECTOR

1. Turn the ignition switch OFF.
2. Disconnect the battery cable from the negative terminal.
3. Check the terminals and connectors of the power steering control module for damage, bend and loose connection (unit side and connector side).

Is the inspection result normal?

- YES >> GO TO 2.
NO >> Repair the terminal and connector.

2. CHECK HARNESS FOR OPEN CIRCUIT

1. Disconnect the connector of power steering control module.
2. Check the resistance between the power steering control module harness connector terminals.

Power steering control module harness connector			Resistance (Ω)
Connector No.	Terminal No.		
E62	8	7	Approx. 54 – 66

Is the measurement value within the specification?

- YES >> GO TO 3.
NO >> Repair the power steering control module branch line.

3. CHECK POWER SUPPLY AND GROUND CIRCUIT

Check the power supply and the ground circuit of the power steering control module. Refer to [STC-22, "Diagnosis Procedure"](#).

Is the inspection result normal?

- YES (Present error)>>Replace the power steering oil pump assembly. Refer to [ST-51, "Removal and Installation"](#).
YES (Past error)>>Error was detected in the power steering control module branch line.
NO >> Repair the power supply and the ground circuit.

A
B
C
D
E
F
G
H
I
J
K
L

LAN

A-BAG BRANCH LINE CIRCUIT

< DTC/CIRCUIT DIAGNOSIS >

[CAN SYSTEM (TYPE 1)]

A-BAG BRANCH LINE CIRCUIT

Diagnosis Procedure

INFOID:000000008970398

WARNING:

- Before servicing, turn ignition switch OFF, disconnect battery negative terminal, and wait 3 minutes or more. (To discharge backup capacitor.)
- Never use unspecified tester or other measuring device.

1.CHECK CONNECTOR

1. Turn the ignition switch OFF.
2. Disconnect the battery cable from the negative terminal.
3. Check the terminals and connectors of the air bag diagnosis sensor unit for damage, bend and loose connection (unit side and connector side).

Is the inspection result normal?

- YES >> GO TO 2.
NO >> Replace the main harness.

2.CHECK AIR BAG DIAGNOSIS SENSOR UNIT

Check the air bag diagnosis sensor unit. Refer to [SRC-40, "Work Flow"](#).

Is the inspection result normal?

- YES >> Replace the main harness.
NO >> Replace parts whose air bag system has a malfunction.

DLC BRANCH LINE CIRCUIT

< DTC/CIRCUIT DIAGNOSIS >

[CAN SYSTEM (TYPE 1)]

DLC BRANCH LINE CIRCUIT

Diagnosis Procedure

INFOID:000000008970400

1. CHECK CONNECTOR

1. Turn the ignition switch OFF.
2. Disconnect the battery cable from the negative terminal.
3. Check the terminals and connectors of the data link connector for damage, bend and loose connection (connector side and harness side).

Is the inspection result normal?

- YES >> GO TO 2.
NO >> Repair the terminal and connector.

2. CHECK HARNESS FOR OPEN CIRCUIT

Check the resistance between the data link connector terminals.

Data link connector			Resistance (Ω)
Connector No.	Terminal No.		
M22	6	14	Approx. 54 – 66

Is the measurement value within the specification?

- YES (Present error)>>Check CAN system type decision again.
YES (Past error)>>Error was detected in the data link connector branch line circuit.
NO >> Repair the data link connector branch line.

A
B
C
D
E
F
G
H
I
J
K
L

LAN

N
O
P

HVAC BRANCH LINE CIRCUIT

< DTC/CIRCUIT DIAGNOSIS >

[CAN SYSTEM (TYPE 1)]

HVAC BRANCH LINE CIRCUIT

Diagnosis Procedure

INFOID:000000008970403

1. CHECK CONNECTOR

1. Turn the ignition switch OFF.
2. Disconnect the battery cable from the negative terminal.
3. Check the terminals and connectors of the A/C auto amp. for damage, bend and loose connection (unit side and connector side).

Is the inspection result normal?

- YES >> GO TO 2.
NO >> Repair the terminal and connector.

2. CHECK HARNESS FOR OPEN CIRCUIT

1. Disconnect the connector of A/C auto amp.
2. Check the resistance between the A/C auto amp. harness connector terminals.

A/C auto amp. harness connector			Resistance (Ω)
Connector No.	Terminal No.		
M50	1	21	Approx. 54 – 66

Is the measurement value within the specification?

- YES >> GO TO 3.
NO >> Repair the A/C auto amp. branch line.

3. CHECK POWER SUPPLY AND GROUND CIRCUIT

Check the power supply and the ground circuit of the A/C auto amp. Refer to [HAC-113, "A/C AUTO AMP. : Diagnosis Procedure"](#).

Is the inspection result normal?

- YES (Present error)>>Replace the A/C auto amp. Refer to [HAC-156, "Removal and Installation"](#).
YES (Past error)>>Error was detected in the A/C auto amp. branch line.
NO >> Repair the power supply and the ground circuit.

M&A BRANCH LINE CIRCUIT

< DTC/CIRCUIT DIAGNOSIS >

[CAN SYSTEM (TYPE 1)]

M&A BRANCH LINE CIRCUIT

Diagnosis Procedure

INFOID:000000008970404

1. CHECK CONNECTOR

1. Turn the ignition switch OFF.
2. Disconnect the battery cable from the negative terminal.
3. Check the terminals and connectors of the combination meter for damage, bend and loose connection (unit side and connector side).

Is the inspection result normal?

- YES >> GO TO 2.
NO >> Repair the terminal and connector.

2. CHECK HARNESS FOR OPEN CIRCUIT

1. Disconnect the connector of combination meter.
2. Check the resistance between the combination meter harness connector terminals.

Combination meter harness connector			Resistance (Ω)
Connector No.	Terminal No.		
M24	39	38	Approx. 54 – 66

Is the measurement value within the specification?

- YES >> GO TO 3.
NO >> Repair the combination meter branch line.

3. CHECK POWER SUPPLY AND GROUND CIRCUIT

Check the power supply and the ground circuit of the combination meter. Refer to [MWI-59, "COMBINATION METER : Diagnosis Procedure"](#).

Is the inspection result normal?

- YES (Present error)>>Replace the combination meter. Refer to [MWI-82, "Removal and Installation"](#).
YES (Past error)>>Error was detected in the combination meter branch line.
NO >> Repair the power supply and the ground circuit.

A
B
C
D
E
F
G
H
I
J
K
L

LAN

STRG BRANCH LINE CIRCUIT

< DTC/CIRCUIT DIAGNOSIS >

[CAN SYSTEM (TYPE 1)]

STRG BRANCH LINE CIRCUIT

Diagnosis Procedure

INFOID:000000008970406

1. CHECK CONNECTOR

1. Turn the ignition switch OFF.
2. Disconnect the battery cable from the negative terminal.
3. Check the terminals and connectors of the steering angle sensor for damage, bend and loose connection (unit side and connector side).

Is the inspection result normal?

- YES >> GO TO 2.
NO >> Repair the terminal and connector.

2. CHECK HARNESS FOR OPEN CIRCUIT

1. Disconnect the connector of steering angle sensor.
2. Check the resistance between the steering angle sensor harness connector terminals.

Steering angle sensor harness connector			Resistance (Ω)
Connector No.	Terminal No.		
M54	5	2	Approx. 54 – 66

Is the measurement value within the specification?

- YES >> GO TO 3.
NO >> Repair the steering angle sensor branch line.

3. CHECK POWER SUPPLY AND GROUND CIRCUIT

Check the power supply and the ground circuit of the steering angle sensor. Refer to [BRC-44, "Wiring Diagram"](#).

Is the inspection result normal?

- YES (Present error)>>Replace the steering angle sensor. Refer to [BRC-124, "Removal and Installation"](#).
YES (Past error)>>Error was detected in the steering angle sensor branch line.
NO >> Repair the power supply and the ground circuit.

BCM BRANCH LINE CIRCUIT

< DTC/CIRCUIT DIAGNOSIS >

[CAN SYSTEM (TYPE 1)]

BCM BRANCH LINE CIRCUIT

Diagnosis Procedure

INFOID:000000008970410

1. CHECK CONNECTOR

1. Turn the ignition switch OFF.
2. Disconnect the battery cable from the negative terminal.
3. Check the following terminals and connectors for damage, bend and loose connection (unit side and connector side).
 - BCM
 - Harness connector M84 (Models without around view monitor)
 - Harness connector B101 (Models without around view monitor)
 - Harness connector B124 (Models without around view monitor)
 - Harness connector B32 (Models without around view monitor)
 - Harness connector B69 (2WD models without automatic back door system)
 - Harness connector M40 (2WD models without automatic back door system)

Is the inspection result normal?

YES >> GO TO 2.

NO >> Repair the terminal and connector.

2. CHECK HARNESS FOR OPEN CIRCUIT

1. Disconnect the connector of BCM.
2. Check the resistance between the BCM harness connector terminals.

BCM harness connector			Resistance (Ω)
Connector No.	Terminal No.		
M19	60	59	Approx. 108 – 132

Is the measurement value within the specification?

YES >> GO TO 3.

NO >> Repair the BCM branch line.

3. CHECK POWER SUPPLY AND GROUND CIRCUIT

Check the power supply and the ground circuit of the BCM. Refer to [BCS-72, "Diagnosis Procedure"](#).

Is the inspection result normal?

YES (Present error)>>Replace the BCM. Refer to [BCS-78, "Removal and Installation"](#).

YES (Past error)>>Error was detected in the BCM branch line.

NO >> Repair the power supply and the ground circuit.

A
B
C
D
E
F
G
H
I
J
K
L

LAN

CAN COMMUNICATION CIRCUIT

< DTC/CIRCUIT DIAGNOSIS >

[CAN SYSTEM (TYPE 1)]

CAN COMMUNICATION CIRCUIT

Diagnosis Procedure

INFOID:000000008970414

1.CONNECTOR INSPECTION

1. Turn the ignition switch OFF.
2. Disconnect the battery cable from the negative terminal.
3. Disconnect all the unit connectors on CAN communication circuit.
4. Check terminals and connectors for damage, bend and loose connection.

Is the inspection result normal?

- YES >> GO TO 2.
NO >> Repair the terminal and connector.

2.CHECK HARNESS CONTINUITY (SHORT CIRCUIT)

Check the continuity between the data link connector terminals.

Data link connector			Continuity
Connector No.	Terminal No.		
M22	6	14	Not existed

Is the inspection result normal?

- YES >> GO TO 3.
NO >> Check the harness and repair the root cause.

3.CHECK HARNESS CONTINUITY (SHORT CIRCUIT)

Check the continuity between the data link connector and the ground.

Data link connector		Ground	Continuity
Connector No.	Terminal No.		
M22	6		Not existed
	14		Not existed

Is the inspection result normal?

- YES >> GO TO 4.
NO >> Check the harness and repair the root cause.

4.CHECK ECM AND BCM TERMINATION CIRCUIT

1. Remove the ECM and the BCM.
2. Check the resistance between the ECM terminals.

ECM		Resistance (Ω)
Terminal No.		
114	113	Approx. 108 – 132

3. Check the resistance between the BCM terminals.

BCM		Resistance (Ω)
Terminal No.		
60	59	Approx. 108 – 132

Is the measurement value within the specification?

- YES >> GO TO 5.
NO >> Replace the ECM and/or the BCM.

5.CHECK SYMPTOM

Connect all the connectors. Check if the symptoms described in the “Symptom (Results from interview with customer)” are reproduced.

CAN COMMUNICATION CIRCUIT

< DTC/CIRCUIT DIAGNOSIS >

[CAN SYSTEM (TYPE 1)]

Inspection result

Reproduced>>GO TO 6.

Non-reproduced>>Start the diagnosis again. Follow the trouble diagnosis procedure when past error is detected.

6.CHECK UNIT REPRODUCTION

Perform the reproduction test as per the following procedure for each unit.

1. Turn the ignition switch OFF.
2. Disconnect the battery cable from the negative terminal.
3. Disconnect one of the unit connectors of CAN communication circuit.

NOTE:

ECM and BCM have a termination circuit. Check other units first.

4. Connect the battery cable to the negative terminal. Check if the symptoms described in the “Symptom (Results from interview with customer)” are reproduced.

NOTE:

Although unit-related error symptoms occur, do not confuse them with other symptoms.

Inspection result

Reproduced>>Connect the connector. Check other units as per the above procedure.

Non-reproduced>>Replace the unit whose connector was disconnected.

A

B

C

D

E

F

G

H

I

J

K

L

LAN

N

O

P

MAIN LINE BETWEEN IPDM-E AND ABS CIRCUIT

< DTC/CIRCUIT DIAGNOSIS >

[CAN SYSTEM (TYPE 2)]

DTC/CIRCUIT DIAGNOSIS

MAIN LINE BETWEEN IPDM-E AND ABS CIRCUIT

Diagnosis Procedure

INFOID:000000008970460

1. CHECK HARNESS CONTINUITY (OPEN CIRCUIT)

1. Turn the ignition switch OFF.
2. Disconnect the battery cable from the negative terminal.
3. Disconnect the following harness connectors.
 - ECM
 - IPDM E/R
 - ABS actuator and electric unit (control unit)
4. Check the continuity between the IPDM E/R harness connector and the ABS actuator and electric unit (control unit) harness connector.

IPDM E/R harness connector		ABS actuator and electric unit (control unit) harness connector		Continuity
Connector No.	Terminal No.	Connector No.	Terminal No.	
E119	29	E125	25	Existed
	28		15	Existed

Is the inspection result normal?

YES (Present error)>>Check CAN system type decision again.

YES (Past error)>>Error was detected in the main line between the IPDM E/R and the ABS actuator and electric unit (control unit).

NO >> Repair the main line between the IPDM E/R and the ABS actuator and electric unit (control unit).

MAIN LINE BETWEEN ABS AND DLC CIRCUIT

< DTC/CIRCUIT DIAGNOSIS >

[CAN SYSTEM (TYPE 2)]

MAIN LINE BETWEEN ABS AND DLC CIRCUIT

Diagnosis Procedure

INFOID:000000008970461

1. CHECK CONNECTOR

1. Turn the ignition switch OFF.
2. Disconnect the battery cable from the negative terminal.
3. Check the following terminals and connectors for damage, bend and loose connection (connector side and harness side).
 - Harness connector E152
 - Harness connector M31

Is the inspection result normal?

YES >> GO TO 2.

NO >> Repair the terminal and connector.

2. CHECK HARNESS CONTINUITY (OPEN CIRCUIT)

1. Disconnect the following harness connectors.
 - ABS actuator and electric unit (control unit)
 - Harness connectors E152 and M31.
2. Check the continuity between the ABS actuator and electric unit (control unit) harness connector and the harness connector.

ABS actuator and electric unit (control unit) harness connector		Harness connector		Continuity
Connector No.	Terminal No.	Connector No.	Terminal No.	
E125	25	E152	36G	Existed
	15		35G	Existed

Is the inspection result normal?

YES >> GO TO 3.

NO >> Repair the main line between the ABS actuator and electric unit (control unit) and the harness connector E152.

3. CHECK HARNESS CONTINUITY (OPEN CIRCUIT)

Check the continuity between the harness connector and the data link connector.

Harness connector		Data link connector		Continuity
Connector No.	Terminal No.	Connector No.	Terminal No.	
M31	36G	M22	6	Existed
	35G		14	Existed

Is the inspection result normal?

YES (Present error)>>Check CAN system type decision again.

YES (Past error)>>Error was detected in the main line between the ABS actuator and electric unit (control unit) and the data link connector.

NO >> Repair the main line between the harness connector M31 and the data link connector.

A
B
C
D
E
F
G
H
I
J
K
L
N
O
P

LAN

ECM BRANCH LINE CIRCUIT

< DTC/CIRCUIT DIAGNOSIS >

[CAN SYSTEM (TYPE 2)]

ECM BRANCH LINE CIRCUIT

Diagnosis Procedure

INFOID:000000008970468

1. CHECK CONNECTOR

1. Turn the ignition switch OFF.
2. Disconnect the battery cable from the negative terminal.
3. Check the terminals and connectors of the ECM for damage, bend and loose connection (unit side and connector side).

Is the inspection result normal?

- YES >> GO TO 2.
NO >> Repair the terminal and connector.

2. CHECK HARNESS FOR OPEN CIRCUIT

1. Disconnect the connector of ECM.
2. Check the resistance between the ECM harness connector terminals.

ECM harness connector			Resistance (Ω)
Connector No.	Terminal No.		
E16	114	113	Approx. 108 – 132

Is the measurement value within the specification?

- YES >> GO TO 3.
NO >> Repair the ECM branch line.

3. CHECK POWER SUPPLY AND GROUND CIRCUIT

Check the power supply and the ground circuit of the ECM. Refer to [EC-170, "Diagnosis Procedure"](#).

Is the inspection result normal?

- YES (Present error)>>Replace the ECM. Refer to [EC-460, "Removal and Installation"](#).
YES (Past error)>>Error was detected in the ECM branch line.
NO >> Repair the power supply and the ground circuit.

IPDM-E BRANCH LINE CIRCUIT

< DTC/CIRCUIT DIAGNOSIS >

[CAN SYSTEM (TYPE 2)]

IPDM-E BRANCH LINE CIRCUIT

Diagnosis Procedure

INFOID:000000008970469

1. CHECK CONNECTOR

1. Turn the ignition switch OFF.
2. Disconnect the battery cable from the negative terminal.
3. Check the terminals and connectors of the IPDM E/R for damage, bend and loose connection (unit side and connector side).

Is the inspection result normal?

- YES >> GO TO 2.
NO >> Repair the terminal and connector.

2. CHECK HARNESS FOR OPEN CIRCUIT

1. Disconnect the connector of IPDM E/R.
2. Check the resistance between the IPDM E/R harness connector terminals.

IPDM E/R harness connector			Resistance (Ω)
Connector No.	Terminal No.		
E119	29	28	Approx. 54 – 66

Is the measurement value within the specification?

- YES >> GO TO 3.
NO >> Repair the IPDM E/R branch line.

3. CHECK POWER SUPPLY AND GROUND CIRCUIT

Check the power supply and the ground circuit of the IPDM E/R. Refer to [PCS-31, "Diagnosis Procedure"](#).

Is the inspection result normal?

- YES (Present error)>>Replace the IPDM E/R. Refer to [PCS-32, "Removal and Installation"](#).
YES (Past error)>>Error was detected in the IPDM E/R branch line.
NO >> Repair the power supply and the ground circuit.

A
B
C
D
E
F
G
H
I
J
K
L
N
O
P

LAN

TCM BRANCH LINE CIRCUIT

< DTC/CIRCUIT DIAGNOSIS >

[CAN SYSTEM (TYPE 2)]

TCM BRANCH LINE CIRCUIT

Diagnosis Procedure

INFOID:000000008970470

1. CHECK CONNECTOR

1. Turn the ignition switch OFF.
2. Disconnect the battery cable from the negative terminal.
3. Check the following terminals and connectors for damage, bend and loose connection (unit side and connector side).
 - TCM
 - Harness connector F32
 - Harness connector E2

Is the inspection result normal?

YES >> GO TO 2.

NO >> Repair the terminal and connector.

2. CHECK HARNESS FOR OPEN CIRCUIT

1. Disconnect the connector of TCM.
2. Check the resistance between the TCM harness connector terminals.

TCM harness connector			Resistance (Ω)
Connector No.	Terminal No.		
F15	33	23	Approx. 54 – 66

Is the measurement value within the specification?

YES >> GO TO 3.

NO >> Repair the TCM branch line.

3. CHECK POWER SUPPLY AND GROUND CIRCUIT

Check the power supply and the ground circuit of the TCM. Refer to [TM-165, "Diagnosis Procedure"](#).

Is the inspection result normal?

YES (Present error)>>Replace the TCM. Refer to [TM-197, "Removal and Installation"](#).

YES (Past error)>>Error was detected in the TCM branch line.

NO >> Repair the power supply and the ground circuit.

ABS BRANCH LINE CIRCUIT

< DTC/CIRCUIT DIAGNOSIS >

[CAN SYSTEM (TYPE 2)]

ABS BRANCH LINE CIRCUIT

Diagnosis Procedure

INFOID:000000008970471

1. CHECK CONNECTOR

1. Turn the ignition switch OFF.
2. Disconnect the battery cable from the negative terminal.
3. Check the terminals and connectors of the ABS actuator and electric unit (control unit) for damage, bend and loose connection (unit side and connector side).

Is the inspection result normal?

- YES >> GO TO 2.
NO >> Repair the terminal and connector.

2. CHECK HARNESS FOR OPEN CIRCUIT

1. Disconnect the connector of ABS actuator and electric unit (control unit).
2. Check the resistance between the ABS actuator and electric unit (control unit) harness connector terminals.

ABS actuator and electric unit (control unit) harness connector			Resistance (Ω)
Connector No.	Terminal No.		
E125	25	15	Approx. 54 – 66

Is the measurement value within the specification?

- YES >> GO TO 3.
NO >> Repair the ABS actuator and electric unit (control unit) branch line.

3. CHECK POWER SUPPLY AND GROUND CIRCUIT

Check the power supply and the ground circuit of the ABS actuator and electric unit (control unit). Refer to [BRC-63, "Diagnosis Procedure"](#).

Is the inspection result normal?

- YES (Present error)>>Replace the ABS actuator and electric unit (control unit). Refer to [BRC-121, "Removal and Installation"](#).
YES (Past error)>>Error was detected in the ABS actuator and electric unit (control unit) branch line.
NO >> Repair the power supply and the ground circuit.

A
B
C
D
E
F
G
H
I
J
K
L

LAN

EPS BRANCH LINE CIRCUIT

Diagnosis Procedure

INFOID:000000008970472

1. CHECK CONNECTOR

1. Turn the ignition switch OFF.
2. Disconnect the battery cable from the negative terminal.
3. Check the terminals and connectors of the power steering control module for damage, bend and loose connection (unit side and connector side).

Is the inspection result normal?

- YES >> GO TO 2.
 NO >> Repair the terminal and connector.

2. CHECK HARNESS FOR OPEN CIRCUIT

1. Disconnect the connector of power steering control module.
2. Check the resistance between the power steering control module harness connector terminals.

Power steering control module harness connector			Resistance (Ω)
Connector No.	Terminal No.		
E62	8	7	Approx. 54 – 66

Is the measurement value within the specification?

- YES >> GO TO 3.
 NO >> Repair the power steering control module branch line.

3. CHECK POWER SUPPLY AND GROUND CIRCUIT

Check the power supply and the ground circuit of the power steering control module. Refer to [STC-22, "Diagnosis Procedure"](#).

Is the inspection result normal?

- YES (Present error)>>Replace the power steering oil pump assembly. Refer to [ST-51, "Removal and Installation"](#).
 YES (Past error)>>Error was detected in the power steering control module branch line.
 NO >> Repair the power supply and the ground circuit.

A-BAG BRANCH LINE CIRCUIT

< DTC/CIRCUIT DIAGNOSIS >

[CAN SYSTEM (TYPE 2)]

A-BAG BRANCH LINE CIRCUIT

Diagnosis Procedure

INFOID:000000008970473

WARNING:

- Before servicing, turn ignition switch OFF, disconnect battery negative terminal, and wait 3 minutes or more. (To discharge backup capacitor.)
- Never use unspecified tester or other measuring device.

1.CHECK CONNECTOR

1. Turn the ignition switch OFF.
2. Disconnect the battery cable from the negative terminal.
3. Check the terminals and connectors of the air bag diagnosis sensor unit for damage, bend and loose connection (unit side and connector side).

Is the inspection result normal?

YES >> GO TO 2.

NO >> Replace the main harness.

2.CHECK AIR BAG DIAGNOSIS SENSOR UNIT

Check the air bag diagnosis sensor unit. Refer to [SRC-40, "Work Flow"](#).

Is the inspection result normal?

YES >> Replace the main harness.

NO >> Replace parts whose air bag system has a malfunction.

A
B
C
D
E
F
G
H
I
J
K
L
N
O
P

LAN

AV BRANCH LINE CIRCUIT

< DTC/CIRCUIT DIAGNOSIS >

[CAN SYSTEM (TYPE 2)]

AV BRANCH LINE CIRCUIT

Diagnosis Procedure

INFOID:000000008970474

1. CHECK CONNECTOR

1. Turn the ignition switch OFF.
2. Disconnect the battery cable from the negative terminal.
3. Check the terminals and connectors of the AV control unit for damage, bend and loose connection (unit side and connector side).

Is the inspection result normal?

- YES >> GO TO 2.
NO >> Repair the terminal and connector.

2. CHECK HARNESS FOR OPEN CIRCUIT

1. Disconnect the connector of AV control unit.
 2. Check the resistance between the AV control unit harness connector terminals.
- With BOSE audio without navigation

AV control unit harness connector			Resistance (Ω)
Connector No.	Terminal No.		
M42	11	12	Approx. 54 – 66

- Without BOSE audio with navigation

AV control unit harness connector			Resistance (Ω)
Connector No.	Terminal No.		
M124	11	12	Approx. 54 – 66

- With BOSE audio with navigation

AV control unit harness connector			Resistance (Ω)
Connector No.	Terminal No.		
M163	78	62	Approx. 54 – 66

Is the measurement value within the specification?

- YES >> GO TO 3.
NO >> Repair the AV control unit branch line.

3. CHECK POWER SUPPLY AND GROUND CIRCUIT

Check the power supply and the ground circuit of the AV control unit. Refer to the following.

- Mid audio without BOSE: [AV-143. "AV CONTROL UNIT : Diagnosis Procedure"](#)
- Mid audio with BOSE: [AV-303. "AV CONTROL UNIT : Diagnosis Procedure"](#)
- Premium audio with navigation: [AV-532. "AV CONTROL UNIT : Diagnosis Procedure"](#)

Is the inspection result normal?

- YES (Present error)>>Replace the AV control unit. Refer to the following.
- Mid audio without BOSE: [AV-186. "Removal and Installation"](#)
 - Mid audio with BOSE: [AV-357. "Removal and Installation"](#)
 - Premium audio with navigation: [AV-585. "Removal and Installation"](#)

YES (Past error)>>Error was detected in the AV control unit branch line.

NO >> Repair the power supply and the ground circuit.

DLC BRANCH LINE CIRCUIT

< DTC/CIRCUIT DIAGNOSIS >

[CAN SYSTEM (TYPE 2)]

DLC BRANCH LINE CIRCUIT

Diagnosis Procedure

INFOID:000000008970475

1. CHECK CONNECTOR

1. Turn the ignition switch OFF.
2. Disconnect the battery cable from the negative terminal.
3. Check the terminals and connectors of the data link connector for damage, bend and loose connection (connector side and harness side).

Is the inspection result normal?

- YES >> GO TO 2.
NO >> Repair the terminal and connector.

2. CHECK HARNESS FOR OPEN CIRCUIT

Check the resistance between the data link connector terminals.

Data link connector			Resistance (Ω)
Connector No.	Terminal No.		
M22	6	14	Approx. 54 – 66

Is the measurement value within the specification?

- YES (Present error)>>Check CAN system type decision again.
YES (Past error)>>Error was detected in the data link connector branch line circuit.
NO >> Repair the data link connector branch line.

A
B
C
D
E
F
G
H
I
J
K
L
N
O
P

LAN

HVAC BRANCH LINE CIRCUIT

< DTC/CIRCUIT DIAGNOSIS >

[CAN SYSTEM (TYPE 2)]

HVAC BRANCH LINE CIRCUIT

Diagnosis Procedure

INFOID:000000008970478

1. CHECK CONNECTOR

1. Turn the ignition switch OFF.
2. Disconnect the battery cable from the negative terminal.
3. Check the terminals and connectors of the A/C auto amp. for damage, bend and loose connection (unit side and connector side).

Is the inspection result normal?

- YES >> GO TO 2.
NO >> Repair the terminal and connector.

2. CHECK HARNESS FOR OPEN CIRCUIT

1. Disconnect the connector of A/C auto amp.
2. Check the resistance between the A/C auto amp. harness connector terminals.

A/C auto amp. harness connector			Resistance (Ω)
Connector No.	Terminal No.		
M50	1	21	Approx. 54 – 66

Is the measurement value within the specification?

- YES >> GO TO 3.
NO >> Repair the A/C auto amp. branch line.

3. CHECK POWER SUPPLY AND GROUND CIRCUIT

Check the power supply and the ground circuit of the A/C auto amp. Refer to [HAC-113, "A/C AUTO AMP. : Diagnosis Procedure"](#).

Is the inspection result normal?

- YES (Present error)>>Replace the A/C auto amp. Refer to [HAC-156, "Removal and Installation"](#).
YES (Past error)>>Error was detected in the A/C auto amp. branch line.
NO >> Repair the power supply and the ground circuit.

M&A BRANCH LINE CIRCUIT

< DTC/CIRCUIT DIAGNOSIS >

[CAN SYSTEM (TYPE 2)]

M&A BRANCH LINE CIRCUIT

Diagnosis Procedure

INFOID:000000008970479

1. CHECK CONNECTOR

1. Turn the ignition switch OFF.
2. Disconnect the battery cable from the negative terminal.
3. Check the terminals and connectors of the combination meter for damage, bend and loose connection (unit side and connector side).

Is the inspection result normal?

- YES >> GO TO 2.
NO >> Repair the terminal and connector.

2. CHECK HARNESS FOR OPEN CIRCUIT

1. Disconnect the connector of combination meter.
2. Check the resistance between the combination meter harness connector terminals.

Combination meter harness connector			Resistance (Ω)
Connector No.	Terminal No.		
M24	39	38	Approx. 54 – 66

Is the measurement value within the specification?

- YES >> GO TO 3.
NO >> Repair the combination meter branch line.

3. CHECK POWER SUPPLY AND GROUND CIRCUIT

Check the power supply and the ground circuit of the combination meter. Refer to [MWI-59, "COMBINATION METER : Diagnosis Procedure"](#).

Is the inspection result normal?

- YES (Present error)>>Replace the combination meter. Refer to [MWI-82, "Removal and Installation"](#).
YES (Past error)>>Error was detected in the combination meter branch line.
NO >> Repair the power supply and the ground circuit.

A
B
C
D
E
F
G
H
I
J
K
L

LAN

SONAR BRANCH LINE CIRCUIT

< DTC/CIRCUIT DIAGNOSIS >

[CAN SYSTEM (TYPE 2)]

SONAR BRANCH LINE CIRCUIT

Diagnosis Procedure

INFOID:000000008970480

1. CHECK CONNECTOR

1. Turn the ignition switch OFF.
2. Disconnect the battery cable from the negative terminal.
3. Check the terminals and connectors of sonar control unit for damage, bend and loose connection (unit side and connector side).

Is the inspection result normal?

- YES >> GO TO 2.
NO >> Repair the terminal and connector.

2. CHECK HARNESS FOR OPEN CIRCUIT

1. Disconnect the connector of sonar control unit.
2. Check the resistance between the sonar control unit harness connector terminals.

Sonar control unit harness connector			Resistance (Ω)
Connector No.	Terminal No.		
M70	5	6	Approx. 54 – 66

Is the measurement value within the specification?

- YES >> GO TO 3.
NO >> Replace the main harness.

3. CHECK POWER SUPPLY AND GROUND CIRCUIT

Check the power supply and the ground circuit of the sonar control unit. Refer to [SN-32, "Diagnosis Procedure"](#).

Is the inspection result normal?

- YES (Present error)>>Replace the sonar control unit. Refer to [SN-34, "Removal and Installation"](#).
YES (Past error)>>Error was detected in the sonar control unit branch line.
NO >> Repair the power supply and the ground circuit.

STRG BRANCH LINE CIRCUIT

< DTC/CIRCUIT DIAGNOSIS >

[CAN SYSTEM (TYPE 2)]

STRG BRANCH LINE CIRCUIT

Diagnosis Procedure

INFOID:000000008970481

1.CHECK CONNECTOR

1. Turn the ignition switch OFF.
2. Disconnect the battery cable from the negative terminal.
3. Check the terminals and connectors of the steering angle sensor for damage, bend and loose connection (unit side and connector side).

Is the inspection result normal?

- YES >> GO TO 2.
NO >> Repair the terminal and connector.

2.CHECK HARNESS FOR OPEN CIRCUIT

1. Disconnect the connector of steering angle sensor.
2. Check the resistance between the steering angle sensor harness connector terminals.

Steering angle sensor harness connector			Resistance (Ω)
Connector No.	Terminal No.		
M54	5	2	Approx. 54 – 66

Is the measurement value within the specification?

- YES >> GO TO 3.
NO >> Repair the steering angle sensor branch line.

3.CHECK POWER SUPPLY AND GROUND CIRCUIT

Check the power supply and the ground circuit of the steering angle sensor. Refer to [BRC-44, "Wiring Diagram"](#).

Is the inspection result normal?

- YES (Present error)>>Replace the steering angle sensor. Refer to [BRC-124, "Removal and Installation"](#).
YES (Past error)>>Error was detected in the steering angle sensor branch line.
NO >> Repair the power supply and the ground circuit.

A
B
C
D
E
F
G
H
I
J
K
L

LAN

N
O
P

BCM BRANCH LINE CIRCUIT

< DTC/CIRCUIT DIAGNOSIS >

[CAN SYSTEM (TYPE 2)]

BCM BRANCH LINE CIRCUIT

Diagnosis Procedure

INFOID:000000008970485

1. CHECK CONNECTOR

1. Turn the ignition switch OFF.
2. Disconnect the battery cable from the negative terminal.
3. Check the following terminals and connectors for damage, bend and loose connection (unit side and connector side).
 - BCM
 - Harness connector M84 (Models without around view monitor)
 - Harness connector B101 (Models without around view monitor)
 - Harness connector B124 (Models without around view monitor)
 - Harness connector B32 (Models without around view monitor)
 - Harness connector B69 (2WD models without automatic back door system)
 - Harness connector M40 (2WD models without automatic back door system)

Is the inspection result normal?

YES >> GO TO 2.

NO >> Repair the terminal and connector.

2. CHECK HARNESS FOR OPEN CIRCUIT

1. Disconnect the connector of BCM.
2. Check the resistance between the BCM harness connector terminals.

BCM harness connector			Resistance (Ω)
Connector No.	Terminal No.		
M19	60	59	Approx. 108 – 132

Is the measurement value within the specification?

YES >> GO TO 3.

NO >> Repair the BCM branch line.

3. CHECK POWER SUPPLY AND GROUND CIRCUIT

Check the power supply and the ground circuit of the BCM. Refer to [BCS-72, "Diagnosis Procedure"](#).

Is the inspection result normal?

YES (Present error)>>Replace the BCM. Refer to [BCS-78, "Removal and Installation"](#).

YES (Past error)>>Error was detected in the BCM branch line.

NO >> Repair the power supply and the ground circuit.

CAN COMMUNICATION CIRCUIT

< DTC/CIRCUIT DIAGNOSIS >

[CAN SYSTEM (TYPE 2)]

CAN COMMUNICATION CIRCUIT

Diagnosis Procedure

INFOID:000000008970489

1. CONNECTOR INSPECTION

1. Turn the ignition switch OFF.
2. Disconnect the battery cable from the negative terminal.
3. Disconnect all the unit connectors on CAN communication circuit.
4. Check terminals and connectors for damage, bend and loose connection.

Is the inspection result normal?

- YES >> GO TO 2.
NO >> Repair the terminal and connector.

2. CHECK HARNESS CONTINUITY (SHORT CIRCUIT)

Check the continuity between the data link connector terminals.

Data link connector		Continuity
Connector No.	Terminal No.	
M22	6 14	Not existed

Is the inspection result normal?

- YES >> GO TO 3.
NO >> Check the harness and repair the root cause.

3. CHECK HARNESS CONTINUITY (SHORT CIRCUIT)

Check the continuity between the data link connector and the ground.

Data link connector		Ground	Continuity
Connector No.	Terminal No.		
M22	6		Not existed
	14		Not existed

Is the inspection result normal?

- YES >> GO TO 4.
NO >> Check the harness and repair the root cause.

4. CHECK ECM AND BCM TERMINATION CIRCUIT

1. Remove the ECM and the BCM.
2. Check the resistance between the ECM terminals.

ECM		Resistance (Ω)
Terminal No.		
114	113	Approx. 108 – 132

3. Check the resistance between the BCM terminals.

BCM		Resistance (Ω)
Terminal No.		
60	59	Approx. 108 – 132

Is the measurement value within the specification?

- YES >> GO TO 5.
NO >> Replace the ECM and/or the BCM.

5. CHECK SYMPTOM

Connect all the connectors. Check if the symptoms described in the "Symptom (Results from interview with customer)" are reproduced.

A
B
C
D
E
F
G
H
I
J
K
L

LAN

N
O
P

CAN COMMUNICATION CIRCUIT

< DTC/CIRCUIT DIAGNOSIS >

[CAN SYSTEM (TYPE 2)]

Inspection result

Reproduced>>GO TO 6.

Non-reproduced>>Start the diagnosis again. Follow the trouble diagnosis procedure when past error is detected.

6.CHECK UNIT REPRODUCTION

Perform the reproduction test as per the following procedure for each unit.

1. Turn the ignition switch OFF.
2. Disconnect the battery cable from the negative terminal.
3. Disconnect one of the unit connectors of CAN communication circuit.

NOTE:

ECM and BCM have a termination circuit. Check other units first.

4. Connect the battery cable to the negative terminal. Check if the symptoms described in the "Symptom (Results from interview with customer)" are reproduced.

NOTE:

Although unit-related error symptoms occur, do not confuse them with other symptoms.

Inspection result

Reproduced>>Connect the connector. Check other units as per the above procedure.

Non-reproduced>>Replace the unit whose connector was disconnected.

MAIN LINE BETWEEN IPDM-E AND ABS CIRCUIT

< DTC/CIRCUIT DIAGNOSIS >

[CAN SYSTEM (TYPE 3)]

DTC/CIRCUIT DIAGNOSIS

MAIN LINE BETWEEN IPDM-E AND ABS CIRCUIT

Diagnosis Procedure

INFOID:000000008970498

1. CHECK HARNESS CONTINUITY (OPEN CIRCUIT)

1. Turn the ignition switch OFF.
2. Disconnect the battery cable from the negative terminal.
3. Disconnect the following harness connectors.
 - ECM
 - IPDM E/R
 - ABS actuator and electric unit (control unit)
4. Check the continuity between the IPDM E/R harness connector and the ABS actuator and electric unit (control unit) harness connector.

IPDM E/R harness connector		ABS actuator and electric unit (control unit) harness connector		Continuity
Connector No.	Terminal No.	Connector No.	Terminal No.	
E119	29	E125	25	Existed
	28		15	Existed

Is the inspection result normal?

YES (Present error)>>Check CAN system type decision again.

YES (Past error)>>Error was detected in the main line between the IPDM E/R and the ABS actuator and electric unit (control unit).

NO >> Repair the main line between the IPDM E/R and the ABS actuator and electric unit (control unit).

A
B
C
D
E
F
G
H
I
J
K
L
N
O
P

LAN

MAIN LINE BETWEEN ABS AND DLC CIRCUIT

< DTC/CIRCUIT DIAGNOSIS >

[CAN SYSTEM (TYPE 3)]

MAIN LINE BETWEEN ABS AND DLC CIRCUIT

Diagnosis Procedure

INFOID:000000008970499

1.CHECK CONNECTOR

1. Turn the ignition switch OFF.
2. Disconnect the battery cable from the negative terminal.
3. Check the following terminals and connectors for damage, bend and loose connection (connector side and harness side).
 - Harness connector E152
 - Harness connector M31

Is the inspection result normal?

YES >> GO TO 2.

NO >> Repair the terminal and connector.

2.CHECK HARNESS CONTINUITY (OPEN CIRCUIT)

1. Disconnect the following harness connectors.
 - ABS actuator and electric unit (control unit)
 - Harness connectors E152 and M31.
2. Check the continuity between the ABS actuator and electric unit (control unit) harness connector and the harness connector.

ABS actuator and electric unit (control unit) harness connector		Harness connector		Continuity
Connector No.	Terminal No.	Connector No.	Terminal No.	
E125	25	E152	36G	Existed
	15		35G	Existed

Is the inspection result normal?

YES >> GO TO 3.

NO >> Repair the main line between the ABS actuator and electric unit (control unit) and the harness connector E152.

3.CHECK HARNESS CONTINUITY (OPEN CIRCUIT)

Check the continuity between the harness connector and the data link connector.

Harness connector		Data link connector		Continuity
Connector No.	Terminal No.	Connector No.	Terminal No.	
M31	36G	M22	6	Existed
	35G		14	Existed

Is the inspection result normal?

YES (Present error)>>Check CAN system type decision again.

YES (Past error)>>Error was detected in the main line between the ABS actuator and electric unit (control unit) and the data link connector.

NO >> Repair the main line between the harness connector M31 and the data link connector.

MAIN LINE BETWEEN DLC AND ADP CIRCUIT

< DTC/CIRCUIT DIAGNOSIS >

[CAN SYSTEM (TYPE 3)]

MAIN LINE BETWEEN DLC AND ADP CIRCUIT

Diagnosis Procedure

INFOID:000000008970503

1.CHECK CONNECTOR

1. Turn the ignition switch OFF.
2. Disconnect the battery cable from the negative terminal.
3. Check the following terminals and connectors for damage, bend and loose connection (connector side and harness side).
 - Harness connector M40
 - Harness connector B69

Is the inspection result normal?

YES >> GO TO 2.

NO >> Repair the terminal and connector.

2.CHECK HARNESS CONTINUITY (OPEN CIRCUIT)

1. Disconnect the harness connectors M40 and B69.
2. Check the continuity between the data link connector and the harness connector.
 - Without around view monitor

Data link connector		Harness connector		Continuity
Connector No.	Terminal No.	Connector No.	Terminal No.	
M22	6	M40	89A	Existed
	14		90A	Existed

- With around view monitor

Data link connector		Harness connector		Continuity
Connector No.	Terminal No.	Connector No.	Terminal No.	
M22	13	M40	89A	Existed
	12		90A	Existed

Is the inspection result normal?

YES >> GO TO 3.

NO >> Repair the main line between the data link connector and the harness connector M40.

3.CHECK HARNESS CONTINUITY (OPEN CIRCUIT)

1. Disconnect the harness connectors B54 and B200.
2. Check the continuity between the harness connectors

Harness connector		Harness connector		Continuity
Connector No.	Terminal No.	Connector No.	Terminal No.	
B69	89A	B54	2	Existed
	90A		1	Existed

Is the inspection result normal?

YES (Present error)>>Check CAN system type decision again.

YES (Past error)>>Error was detected in the main line between the data link connector and the driver seat control unit.

NO >> Repair the main line between the harness connectors B69 and B54.

MAIN LINE BETWEEN ADP AND PWBD CIRCUIT

< DTC/CIRCUIT DIAGNOSIS >

[CAN SYSTEM (TYPE 3)]

MAIN LINE BETWEEN ADP AND PWBD CIRCUIT

Diagnosis Procedure

INFOID:000000008970504

1. CHECK HARNESS CONTINUITY (OPEN CIRCUIT)

1. Turn the ignition switch OFF.
2. Disconnect the battery cable from the negative terminal.
3. Disconnect the following harness connectors.
 - ECM (Models without around view monitor)
 - CAN gateway (Models with around view monitor)
 - Harness connector B54 and B200
 - Automatic back door control module
4. Check the continuity between the harness connector and the automatic back door control module harness connector.

Harness connector		Automatic back door control module harness connector		Continuity
Connector No.	Terminal No.	Connector No.	Terminal No.	
B54	1	B55	24	Existed
	2		12	Existed

Is the inspection result normal?

YES (Present error)>>Check CAN system type decision again.

YES (Past error)>>Error was detected in the main line between the driver seat control unit and the automatic back door control module.

NO >> Repair the main line between the harness connector B54 and the automatic back door control module.

ECM BRANCH LINE CIRCUIT

< DTC/CIRCUIT DIAGNOSIS >

[CAN SYSTEM (TYPE 3)]

ECM BRANCH LINE CIRCUIT

Diagnosis Procedure

INFOID:000000008970506

1. CHECK CONNECTOR

1. Turn the ignition switch OFF.
2. Disconnect the battery cable from the negative terminal.
3. Check the terminals and connectors of the ECM for damage, bend and loose connection (unit side and connector side).

Is the inspection result normal?

- YES >> GO TO 2.
NO >> Repair the terminal and connector.

2. CHECK HARNESS FOR OPEN CIRCUIT

1. Disconnect the connector of ECM.
2. Check the resistance between the ECM harness connector terminals.

ECM harness connector			Resistance (Ω)
Connector No.	Terminal No.		
E16	114	113	Approx. 108 – 132

Is the measurement value within the specification?

- YES >> GO TO 3.
NO >> Repair the ECM branch line.

3. CHECK POWER SUPPLY AND GROUND CIRCUIT

Check the power supply and the ground circuit of the ECM. Refer to [EC-170. "Diagnosis Procedure"](#).

Is the inspection result normal?

- YES (Present error)>>Replace the ECM. Refer to [EC-460. "Removal and Installation"](#).
YES (Past error)>>Error was detected in the ECM branch line.
NO >> Repair the power supply and the ground circuit.

A
B
C
D
E
F
G
H
I
J
K
L

LAN

N
O
P

IPDM-E BRANCH LINE CIRCUIT

< DTC/CIRCUIT DIAGNOSIS >

[CAN SYSTEM (TYPE 3)]

IPDM-E BRANCH LINE CIRCUIT

Diagnosis Procedure

INFOID:000000008970507

1. CHECK CONNECTOR

1. Turn the ignition switch OFF.
2. Disconnect the battery cable from the negative terminal.
3. Check the terminals and connectors of the IPDM E/R for damage, bend and loose connection (unit side and connector side).

Is the inspection result normal?

- YES >> GO TO 2.
NO >> Repair the terminal and connector.

2. CHECK HARNESS FOR OPEN CIRCUIT

1. Disconnect the connector of IPDM E/R.
2. Check the resistance between the IPDM E/R harness connector terminals.

IPDM E/R harness connector			Resistance (Ω)
Connector No.	Terminal No.		
E119	29	28	Approx. 54 – 66

Is the measurement value within the specification?

- YES >> GO TO 3.
NO >> Repair the IPDM E/R branch line.

3. CHECK POWER SUPPLY AND GROUND CIRCUIT

Check the power supply and the ground circuit of the IPDM E/R. Refer to [PCS-31, "Diagnosis Procedure"](#).

Is the inspection result normal?

- YES (Present error)>>Replace the IPDM E/R. Refer to [PCS-32, "Removal and Installation"](#).
YES (Past error)>>Error was detected in the IPDM E/R branch line.
NO >> Repair the power supply and the ground circuit.

TCM BRANCH LINE CIRCUIT

< DTC/CIRCUIT DIAGNOSIS >

[CAN SYSTEM (TYPE 3)]

TCM BRANCH LINE CIRCUIT

Diagnosis Procedure

INFOID:000000008970508

1. CHECK CONNECTOR

1. Turn the ignition switch OFF.
2. Disconnect the battery cable from the negative terminal.
3. Check the following terminals and connectors for damage, bend and loose connection (unit side and connector side).
 - TCM
 - Harness connector F32
 - Harness connector E2

Is the inspection result normal?

- YES >> GO TO 2.
NO >> Repair the terminal and connector.

2. CHECK HARNESS FOR OPEN CIRCUIT

1. Disconnect the connector of TCM.
2. Check the resistance between the TCM harness connector terminals.

TCM harness connector		Resistance (Ω)
Connector No.	Terminal No.	
F15	33 23	Approx. 54 – 66

Is the measurement value within the specification?

- YES >> GO TO 3.
NO >> Repair the TCM branch line.

3. CHECK POWER SUPPLY AND GROUND CIRCUIT

Check the power supply and the ground circuit of the TCM. Refer to [TM-165, "Diagnosis Procedure"](#).

Is the inspection result normal?

- YES (Present error)>>Replace the TCM. Refer to [TM-197, "Removal and Installation"](#).
YES (Past error)>>Error was detected in the TCM branch line.
NO >> Repair the power supply and the ground circuit.

A
B
C
D
E
F
G
H
I
J
K
L

LAN

ABS BRANCH LINE CIRCUIT

< DTC/CIRCUIT DIAGNOSIS >

[CAN SYSTEM (TYPE 3)]

ABS BRANCH LINE CIRCUIT

Diagnosis Procedure

INFOID:000000008970509

1. CHECK CONNECTOR

1. Turn the ignition switch OFF.
2. Disconnect the battery cable from the negative terminal.
3. Check the terminals and connectors of the ABS actuator and electric unit (control unit) for damage, bend and loose connection (unit side and connector side).

Is the inspection result normal?

- YES >> GO TO 2.
NO >> Repair the terminal and connector.

2. CHECK HARNESS FOR OPEN CIRCUIT

1. Disconnect the connector of ABS actuator and electric unit (control unit).
2. Check the resistance between the ABS actuator and electric unit (control unit) harness connector terminals.

ABS actuator and electric unit (control unit) harness connector			Resistance (Ω)
Connector No.	Terminal No.		
E125	25	15	Approx. 54 – 66

Is the measurement value within the specification?

- YES >> GO TO 3.
NO >> Repair the ABS actuator and electric unit (control unit) branch line.

3. CHECK POWER SUPPLY AND GROUND CIRCUIT

Check the power supply and the ground circuit of the ABS actuator and electric unit (control unit). Refer to [BRC-63, "Diagnosis Procedure"](#).

Is the inspection result normal?

- YES (Present error)>>Replace the ABS actuator and electric unit (control unit). Refer to [BRC-121, "Removal and Installation"](#).
YES (Past error)>>Error was detected in the ABS actuator and electric unit (control unit) branch line.
NO >> Repair the power supply and the ground circuit.

EPS BRANCH LINE CIRCUIT

< DTC/CIRCUIT DIAGNOSIS >

[CAN SYSTEM (TYPE 3)]

EPS BRANCH LINE CIRCUIT

Diagnosis Procedure

INFOID:000000008970510

1. CHECK CONNECTOR

1. Turn the ignition switch OFF.
2. Disconnect the battery cable from the negative terminal.
3. Check the terminals and connectors of the power steering control module for damage, bend and loose connection (unit side and connector side).

Is the inspection result normal?

- YES >> GO TO 2.
NO >> Repair the terminal and connector.

2. CHECK HARNESS FOR OPEN CIRCUIT

1. Disconnect the connector of power steering control module.
2. Check the resistance between the power steering control module harness connector terminals.

Power steering control module harness connector			Resistance (Ω)
Connector No.	Terminal No.		
E62	8	7	Approx. 54 – 66

Is the measurement value within the specification?

- YES >> GO TO 3.
NO >> Repair the power steering control module branch line.

3. CHECK POWER SUPPLY AND GROUND CIRCUIT

Check the power supply and the ground circuit of the power steering control module. Refer to [STC-22, "Diagnosis Procedure"](#).

Is the inspection result normal?

- YES (Present error)>>Replace the power steering oil pump assembly. Refer to [ST-51, "Removal and Installation"](#).
YES (Past error)>>Error was detected in the power steering control module branch line.
NO >> Repair the power supply and the ground circuit.

A
B
C
D
E
F
G
H
I
J
K
L

LAN

A-BAG BRANCH LINE CIRCUIT

< DTC/CIRCUIT DIAGNOSIS >

[CAN SYSTEM (TYPE 3)]

A-BAG BRANCH LINE CIRCUIT

Diagnosis Procedure

INFOID:000000008970511

WARNING:

- Before servicing, turn ignition switch OFF, disconnect battery negative terminal, and wait 3 minutes or more. (To discharge backup capacitor.)
- Never use unspecified tester or other measuring device.

1.CHECK CONNECTOR

1. Turn the ignition switch OFF.
2. Disconnect the battery cable from the negative terminal.
3. Check the terminals and connectors of the air bag diagnosis sensor unit for damage, bend and loose connection (unit side and connector side).

Is the inspection result normal?

YES >> GO TO 2.

NO >> Replace the main harness.

2.CHECK AIR BAG DIAGNOSIS SENSOR UNIT

Check the air bag diagnosis sensor unit. Refer to [SRC-40, "Work Flow"](#).

Is the inspection result normal?

YES >> Replace the main harness.

NO >> Replace parts whose air bag system has a malfunction.

AV BRANCH LINE CIRCUIT

< DTC/CIRCUIT DIAGNOSIS >

[CAN SYSTEM (TYPE 3)]

AV BRANCH LINE CIRCUIT

Diagnosis Procedure

INFOID:000000008970512

1. CHECK CONNECTOR

1. Turn the ignition switch OFF.
2. Disconnect the battery cable from the negative terminal.
3. Check the terminals and connectors of the AV control unit for damage, bend and loose connection (unit side and connector side).

Is the inspection result normal?

- YES >> GO TO 2.
NO >> Repair the terminal and connector.

2. CHECK HARNESS FOR OPEN CIRCUIT

1. Disconnect the connector of AV control unit.
 2. Check the resistance between the AV control unit harness connector terminals.
- With BOSE audio without navigation

AV control unit harness connector			Resistance (Ω)
Connector No.	Terminal No.		
M42	11	12	Approx. 54 – 66

- Without BOSE audio with navigation

AV control unit harness connector			Resistance (Ω)
Connector No.	Terminal No.		
M124	11	12	Approx. 54 – 66

- With BOSE audio with navigation

AV control unit harness connector			Resistance (Ω)
Connector No.	Terminal No.		
M163	78	62	Approx. 54 – 66

Is the measurement value within the specification?

- YES >> GO TO 3.
NO >> Repair the AV control unit branch line.

3. CHECK POWER SUPPLY AND GROUND CIRCUIT

Check the power supply and the ground circuit of the AV control unit. Refer to the following.

- Mid audio without BOSE: [AV-143, "AV CONTROL UNIT : Diagnosis Procedure"](#)
- Mid audio with BOSE: [AV-303, "AV CONTROL UNIT : Diagnosis Procedure"](#)
- Premium audio with navigation: [AV-532, "AV CONTROL UNIT : Diagnosis Procedure"](#)

Is the inspection result normal?

- YES (Present error)>>Replace the AV control unit. Refer to the following.
- Mid audio without BOSE: [AV-186, "Removal and Installation"](#)
 - Mid audio with BOSE: [AV-357, "Removal and Installation"](#)
 - Premium audio with navigation: [AV-585, "Removal and Installation"](#)

YES (Past error)>>Error was detected in the AV control unit branch line.

- NO >> Repair the power supply and the ground circuit.

A
B
C
D
E
F
G
H
I
J
K
L
N
O
P

LAN

DLC BRANCH LINE CIRCUIT

< DTC/CIRCUIT DIAGNOSIS >

[CAN SYSTEM (TYPE 3)]

DLC BRANCH LINE CIRCUIT

Diagnosis Procedure

INFOID:000000008970513

1. CHECK CONNECTOR

1. Turn the ignition switch OFF.
2. Disconnect the battery cable from the negative terminal.
3. Check the terminals and connectors of the data link connector for damage, bend and loose connection (connector side and harness side).

Is the inspection result normal?

- YES >> GO TO 2.
NO >> Repair the terminal and connector.

2. CHECK HARNESS FOR OPEN CIRCUIT

Check the resistance between the data link connector terminals.

Data link connector			Resistance (Ω)
Connector No.	Terminal No.		
M22	6	14	Approx. 54 – 66

Is the measurement value within the specification?

- YES (Present error)>>Check CAN system type decision again.
YES (Past error)>>Error was detected in the data link connector branch line circuit.
NO >> Repair the data link connector branch line.

HVAC BRANCH LINE CIRCUIT

< DTC/CIRCUIT DIAGNOSIS >

[CAN SYSTEM (TYPE 3)]

HVAC BRANCH LINE CIRCUIT

Diagnosis Procedure

INFOID:000000008970516

1. CHECK CONNECTOR

1. Turn the ignition switch OFF.
2. Disconnect the battery cable from the negative terminal.
3. Check the terminals and connectors of the A/C auto amp. for damage, bend and loose connection (unit side and connector side).

Is the inspection result normal?

- YES >> GO TO 2.
NO >> Repair the terminal and connector.

2. CHECK HARNESS FOR OPEN CIRCUIT

1. Disconnect the connector of A/C auto amp.
2. Check the resistance between the A/C auto amp. harness connector terminals.

A/C auto amp. harness connector			Resistance (Ω)
Connector No.	Terminal No.		
M50	1	21	Approx. 54 – 66

Is the measurement value within the specification?

- YES >> GO TO 3.
NO >> Repair the A/C auto amp. branch line.

3. CHECK POWER SUPPLY AND GROUND CIRCUIT

Check the power supply and the ground circuit of the A/C auto amp. Refer to [HAC-113, "A/C AUTO AMP. : Diagnosis Procedure"](#).

Is the inspection result normal?

- YES (Present error)>>Replace the A/C auto amp. Refer to [HAC-156, "Removal and Installation"](#).
YES (Past error)>>Error was detected in the A/C auto amp. branch line.
NO >> Repair the power supply and the ground circuit.

A
B
C
D
E
F
G
H
I
J
K
L
LAN
N
O
P

M&A BRANCH LINE CIRCUIT

Diagnosis Procedure

INFOID:000000008970517

1. CHECK CONNECTOR

1. Turn the ignition switch OFF.
2. Disconnect the battery cable from the negative terminal.
3. Check the terminals and connectors of the combination meter for damage, bend and loose connection (unit side and connector side).

Is the inspection result normal?

- YES >> GO TO 2.
 NO >> Repair the terminal and connector.

2. CHECK HARNESS FOR OPEN CIRCUIT

1. Disconnect the connector of combination meter.
2. Check the resistance between the combination meter harness connector terminals.

Combination meter harness connector			Resistance (Ω)
Connector No.	Terminal No.		
M24	39	38	Approx. 54 – 66

Is the measurement value within the specification?

- YES >> GO TO 3.
 NO >> Repair the combination meter branch line.

3. CHECK POWER SUPPLY AND GROUND CIRCUIT

Check the power supply and the ground circuit of the combination meter. Refer to [MWI-59, "COMBINATION METER : Diagnosis Procedure"](#).

Is the inspection result normal?

- YES (Present error)>>Replace the combination meter. Refer to [MWI-82, "Removal and Installation"](#).
 YES (Past error)>>Error was detected in the combination meter branch line.
 NO >> Repair the power supply and the ground circuit.

SONAR BRANCH LINE CIRCUIT

< DTC/CIRCUIT DIAGNOSIS >

[CAN SYSTEM (TYPE 3)]

SONAR BRANCH LINE CIRCUIT

Diagnosis Procedure

INFOID:000000008970518

1. CHECK CONNECTOR

1. Turn the ignition switch OFF.
2. Disconnect the battery cable from the negative terminal.
3. Check the terminals and connectors of sonar control unit for damage, bend and loose connection (unit side and connector side).

Is the inspection result normal?

- YES >> GO TO 2.
NO >> Repair the terminal and connector.

2. CHECK HARNESS FOR OPEN CIRCUIT

1. Disconnect the connector of sonar control unit.
2. Check the resistance between the sonar control unit harness connector terminals.

Sonar control unit harness connector			Resistance (Ω)
Connector No.	Terminal No.		
M70	5	6	Approx. 54 – 66

Is the measurement value within the specification?

- YES >> GO TO 3.
NO >> Replace the main harness.

3. CHECK POWER SUPPLY AND GROUND CIRCUIT

Check the power supply and the ground circuit of the sonar control unit. Refer to [SN-32, "Diagnosis Procedure"](#).

Is the inspection result normal?

- YES (Present error)>>Replace the sonar control unit. Refer to [SN-34, "Removal and Installation"](#).
YES (Past error)>>Error was detected in the sonar control unit branch line.
NO >> Repair the power supply and the ground circuit.

A
B
C
D
E
F
G
H
I
J
K
L

LAN

STRG BRANCH LINE CIRCUIT

< DTC/CIRCUIT DIAGNOSIS >

[CAN SYSTEM (TYPE 3)]

STRG BRANCH LINE CIRCUIT

Diagnosis Procedure

INFOID:000000008970519

1. CHECK CONNECTOR

1. Turn the ignition switch OFF.
2. Disconnect the battery cable from the negative terminal.
3. Check the terminals and connectors of the steering angle sensor for damage, bend and loose connection (unit side and connector side).

Is the inspection result normal?

- YES >> GO TO 2.
NO >> Repair the terminal and connector.

2. CHECK HARNESS FOR OPEN CIRCUIT

1. Disconnect the connector of steering angle sensor.
2. Check the resistance between the steering angle sensor harness connector terminals.

Steering angle sensor harness connector			Resistance (Ω)
Connector No.	Terminal No.		
M54	5	2	Approx. 54 – 66

Is the measurement value within the specification?

- YES >> GO TO 3.
NO >> Repair the steering angle sensor branch line.

3. CHECK POWER SUPPLY AND GROUND CIRCUIT

Check the power supply and the ground circuit of the steering angle sensor. Refer to [BRC-44, "Wiring Diagram"](#).

Is the inspection result normal?

- YES (Present error)>>Replace the steering angle sensor. Refer to [BRC-124, "Removal and Installation"](#).
YES (Past error)>>Error was detected in the steering angle sensor branch line.
NO >> Repair the power supply and the ground circuit.

ADP BRANCH LINE CIRCUIT

< DTC/CIRCUIT DIAGNOSIS >

[CAN SYSTEM (TYPE 3)]

ADP BRANCH LINE CIRCUIT

Diagnosis Procedure

INFOID:000000008970520

1. CHECK CONNECTOR

1. Turn the ignition switch OFF.
2. Disconnect the battery cable from the negative terminal.
3. Check the following terminals and connectors for damage, bend and loose connection (unit side and connector side).
 - Driver seat control unit
 - Harness connector B200
 - Harness connector B54
 - CAN gateway (Models with around view monitor)

Is the inspection result normal?

- YES-1 >> Models with around view monitor: GO TO 2.
YES-2 >> Models without around view monitor: GO TO 3.
NO >> Repair the terminal and connector.

2. CHECK HARNESS CONTINUITY (OPEN CIRCUIT)

1. Disconnect the connector of CAN gateway.
2. Check the continuity between the CAN gateway harness connector terminals.

CAN gateway harness connector			Continuity
Connector No.	Terminal No.		
M5	4	6	Existed
	10	12	Existed

Is the inspection result normal?

- YES >> GO TO 3.
NO >> Check the harness and repair the root cause (CAN communication circuit 2 side).

3. CHECK HARNESS FOR OPEN CIRCUIT

1. Connect the connector of CAN gateway. (Models with around view monitor)
2. Disconnect the connector of driver seat control unit.
3. Check the resistance between the driver seat control unit harness connector terminals.

Driver seat control unit harness connector			Resistance (Ω)
Connector No.	Terminal No.		
B209	16	32	Approx. 54 – 66

Is the measurement value within the specification?

- YES >> GO TO 4.
NO >> Repair the driver seat control unit branch line.

4. CHECK POWER SUPPLY AND GROUND CIRCUIT

Check the power supply and the ground circuit of the driver seat control unit. Refer to [ADP-83, "DRIVER SEAT CONTROL UNIT : Diagnosis Procedure"](#).

Is the inspection result normal?

- YES (Present error)>>Replace the driver seat control unit. Refer to [ADP-156, "Removal and Installation"](#).
YES (Past error)>>Error was detected in the driver seat control unit branch line.
NO >> Repair the power supply and the ground circuit.

A
B
C
D
E
F
G
H
I
J
K
L
N
O
P

LAN

PWBD BRANCH LINE CIRCUIT

Diagnosis Procedure

INFOID:000000008970522

1. CHECK CONNECTOR

1. Turn the ignition switch OFF.
2. Disconnect the battery cable from the negative terminal.
3. Check the following terminals and connectors for damage, bend and loose connection (unit side and connector side).
 - Automatic back door control module
 - CAN gateway (Models with around view monitor)

Is the inspection result normal?

- YES-1 >> Models with around view monitor: GO TO 2.
- YES-2 >> Models without around view monitor: GO TO 3.
- NO >> Repair the terminal and connector.

2. CHECK HARNESS CONTINUITY (OPEN CIRCUIT)

1. Disconnect the connector of CAN gateway.
2. Check the continuity between the CAN gateway harness connector terminals.

CAN gateway harness connector		Continuity	
Connector No.	Terminal No.		
M5	4	6	Existed
	10	12	Existed

Is the inspection result normal?

- YES >> GO TO 3.
- NO >> Check the harness and repair the root cause (CAN communication circuit 2 side).

3. CHECK HARNESS FOR OPEN CIRCUIT

1. Connect the connector of CAN gateway. (Models with around view monitor)
2. Disconnect the connector of automatic back door control module.
3. Check the resistance between the automatic back door control module harness connector terminals.

Automatic back door control module harness connector		Resistance (Ω)	
Connector No.	Terminal No.		
B55	24	12	Approx. 54 – 66

Is the measurement value within the specification?

- YES >> GO TO 4.
- NO >> Replace the body harness.

4. CHECK POWER SUPPLY AND GROUND CIRCUIT

Check the power supply and the ground circuit of the automatic back door control module. Refer to [DLK-160, "AUTOMATIC BACK DOOR CONTROL UNIT : Diagnosis Procedure"](#).

Is the inspection result normal?

- YES (Present error)>>Replace the automatic back door control module. Refer to [DLK-317, "Removal and Installation"](#).
- YES (Past error)>>Error was detected in the automatic back door control module branch line.
- NO >> Repair the power supply and the ground circuit.

BCM BRANCH LINE CIRCUIT

< DTC/CIRCUIT DIAGNOSIS >

[CAN SYSTEM (TYPE 3)]

BCM BRANCH LINE CIRCUIT

Diagnosis Procedure

INFOID:000000008970523

1. CHECK CONNECTOR

1. Turn the ignition switch OFF.
2. Disconnect the battery cable from the negative terminal.
3. Check the following terminals and connectors for damage, bend and loose connection (unit side and connector side).
 - BCM
 - Harness connector M84 (Models without around view monitor)
 - Harness connector B101 (Models without around view monitor)
 - Harness connector B124 (Models without around view monitor)
 - Harness connector B32 (Models without around view monitor)
 - Harness connector B69 (2WD models without automatic back door system)
 - Harness connector M40 (2WD models without automatic back door system)

Is the inspection result normal?

YES >> GO TO 2.

NO >> Repair the terminal and connector.

2. CHECK HARNESS FOR OPEN CIRCUIT

1. Disconnect the connector of BCM.
2. Check the resistance between the BCM harness connector terminals.

BCM harness connector			Resistance (Ω)
Connector No.	Terminal No.		
M19	60	59	Approx. 108 – 132

Is the measurement value within the specification?

YES >> GO TO 3.

NO >> Repair the BCM branch line.

3. CHECK POWER SUPPLY AND GROUND CIRCUIT

Check the power supply and the ground circuit of the BCM. Refer to [BCS-72, "Diagnosis Procedure"](#).

Is the inspection result normal?

YES (Present error)>>Replace the BCM. Refer to [BCS-78, "Removal and Installation"](#).

YES (Past error)>>Error was detected in the BCM branch line.

NO >> Repair the power supply and the ground circuit.

A
B
C
D
E
F
G
H
I
J
K
L

LAN

CAN COMMUNICATION CIRCUIT

< DTC/CIRCUIT DIAGNOSIS >

[CAN SYSTEM (TYPE 3)]

CAN COMMUNICATION CIRCUIT

Diagnosis Procedure

INFOID:000000008970527

1. CONNECTOR INSPECTION

1. Turn the ignition switch OFF.
2. Disconnect the battery cable from the negative terminal.
3. Disconnect all the unit connectors on CAN communication circuit.
4. Check terminals and connectors for damage, bend and loose connection.

Is the inspection result normal?

- YES >> GO TO 2.
NO >> Repair the terminal and connector.

2. CHECK HARNESS CONTINUITY (SHORT CIRCUIT)

Check the continuity between the data link connector terminals.

Data link connector		Continuity
Connector No.	Terminal No.	
M22	6 14	Not existed

Is the inspection result normal?

- YES >> GO TO 3.
NO >> Check the harness and repair the root cause.

3. CHECK HARNESS CONTINUITY (SHORT CIRCUIT)

Check the continuity between the data link connector and the ground.

Data link connector		Ground	Continuity
Connector No.	Terminal No.		
M22	6		Not existed
	14		Not existed

Is the inspection result normal?

- YES >> GO TO 4.
NO >> Check the harness and repair the root cause.

4. CHECK ECM AND BCM TERMINATION CIRCUIT

1. Remove the ECM and the BCM.
2. Check the resistance between the ECM terminals.

ECM		Resistance (Ω)
Terminal No.		
114	113	Approx. 108 – 132

3. Check the resistance between the BCM terminals.

BCM		Resistance (Ω)
Terminal No.		
60	59	Approx. 108 – 132

Is the measurement value within the specification?

- YES >> GO TO 5.
NO >> Replace the ECM and/or the BCM.

5. CHECK SYMPTOM

Connect all the connectors. Check if the symptoms described in the "Symptom (Results from interview with customer)" are reproduced.

CAN COMMUNICATION CIRCUIT

< DTC/CIRCUIT DIAGNOSIS >

[CAN SYSTEM (TYPE 3)]

Inspection result

Reproduced>>GO TO 6.

Non-reproduced>>Start the diagnosis again. Follow the trouble diagnosis procedure when past error is detected.

6.CHECK UNIT REPRODUCTION

Perform the reproduction test as per the following procedure for each unit.

1. Turn the ignition switch OFF.
2. Disconnect the battery cable from the negative terminal.
3. Disconnect one of the unit connectors of CAN communication circuit.

NOTE:

ECM and BCM have a termination circuit. Check other units first.

4. Connect the battery cable to the negative terminal. Check if the symptoms described in the “Symptom (Results from interview with customer)” are reproduced.

NOTE:

Although unit-related error symptoms occur, do not confuse them with other symptoms.

Inspection result

Reproduced>>Connect the connector. Check other units as per the above procedure.

Non-reproduced>>Replace the unit whose connector was disconnected.

A
B
C
D
E
F
G
H
I
J
K
L
N
O
P

LAN

MAIN LINE BETWEEN IPDM-E AND ABS CIRCUIT

< DTC/CIRCUIT DIAGNOSIS >

[CAN SYSTEM (TYPE 4)]

DTC/CIRCUIT DIAGNOSIS

MAIN LINE BETWEEN IPDM-E AND ABS CIRCUIT

Diagnosis Procedure

INFOID:000000008970530

1. CHECK HARNESS CONTINUITY (OPEN CIRCUIT)

1. Turn the ignition switch OFF.
2. Disconnect the battery cable from the negative terminal.
3. Disconnect the following harness connectors.
 - ECM
 - IPDM E/R
 - ABS actuator and electric unit (control unit)
4. Check the continuity between the IPDM E/R harness connector and the ABS actuator and electric unit (control unit) harness connector.

IPDM E/R harness connector		ABS actuator and electric unit (control unit) harness connector		Continuity
Connector No.	Terminal No.	Connector No.	Terminal No.	
E119	29	E125	25	Existed
	28		15	Existed

Is the inspection result normal?

YES (Present error)>>Check CAN system type decision again.

YES (Past error)>>Error was detected in the main line between the IPDM E/R and the ABS actuator and electric unit (control unit).

NO >> Repair the main line between the IPDM E/R and the ABS actuator and electric unit (control unit).

MAIN LINE BETWEEN ABS AND DLC CIRCUIT

< DTC/CIRCUIT DIAGNOSIS >

[CAN SYSTEM (TYPE 4)]

MAIN LINE BETWEEN ABS AND DLC CIRCUIT

Diagnosis Procedure

INFOID:000000008970531

1. CHECK CONNECTOR

1. Turn the ignition switch OFF.
2. Disconnect the battery cable from the negative terminal.
3. Check the following terminals and connectors for damage, bend and loose connection (connector side and harness side).
 - Harness connector E152
 - Harness connector M31

Is the inspection result normal?

YES >> GO TO 2.

NO >> Repair the terminal and connector.

2. CHECK HARNESS CONTINUITY (OPEN CIRCUIT)

1. Disconnect the following harness connectors.
 - ABS actuator and electric unit (control unit)
 - Harness connectors E152 and M31.
2. Check the continuity between the ABS actuator and electric unit (control unit) harness connector and the harness connector.

ABS actuator and electric unit (control unit) harness connector		Harness connector		Continuity
Connector No.	Terminal No.	Connector No.	Terminal No.	
E125	25	E152	36G	Existed
	15		35G	Existed

Is the inspection result normal?

YES >> GO TO 3.

NO >> Repair the main line between the ABS actuator and electric unit (control unit) and the harness connector E152.

3. CHECK HARNESS CONTINUITY (OPEN CIRCUIT)

Check the continuity between the harness connector and the data link connector.

Harness connector		Data link connector		Continuity
Connector No.	Terminal No.	Connector No.	Terminal No.	
M31	36G	M22	6	Existed
	35G		14	Existed

Is the inspection result normal?

YES (Present error)>>Check CAN system type decision again.

YES (Past error)>>Error was detected in the main line between the ABS actuator and electric unit (control unit) and the data link connector.

NO >> Repair the main line between the harness connector M31 and the data link connector.

A
B
C
D
E
F
G
H
I
J
K
L
LAN
N
O
P

MAIN LINE BETWEEN DLC AND ADP CIRCUIT

< DTC/CIRCUIT DIAGNOSIS >

[CAN SYSTEM (TYPE 4)]

MAIN LINE BETWEEN DLC AND ADP CIRCUIT

Diagnosis Procedure

INFOID:000000008970535

1.CHECK CONNECTOR

1. Turn the ignition switch OFF.
2. Disconnect the battery cable from the negative terminal.
3. Check the following terminals and connectors for damage, bend and loose connection (connector side and harness side).
 - Harness connector M40
 - Harness connector B69

Is the inspection result normal?

YES >> GO TO 2.

NO >> Repair the terminal and connector.

2.CHECK HARNESS CONTINUITY (OPEN CIRCUIT)

1. Disconnect the harness connectors M40 and B69.
2. Check the continuity between the data link connector and the harness connector.
 - Without around view monitor

Data link connector		Harness connector		Continuity
Connector No.	Terminal No.	Connector No.	Terminal No.	
M22	6	M40	89A	Existed
	14		90A	Existed

- With around view monitor

Data link connector		Harness connector		Continuity
Connector No.	Terminal No.	Connector No.	Terminal No.	
M22	13	M40	89A	Existed
	12		90A	Existed

Is the inspection result normal?

YES >> GO TO 3.

NO >> Repair the main line between the data link connector and the harness connector M40.

3.CHECK HARNESS CONTINUITY (OPEN CIRCUIT)

1. Disconnect the harness connectors B54 and B200.
2. Check the continuity between the harness connectors

Harness connector		Harness connector		Continuity
Connector No.	Terminal No.	Connector No.	Terminal No.	
B69	89A	B54	2	Existed
	90A		1	Existed

Is the inspection result normal?

YES (Present error)>>Check CAN system type decision again.

YES (Past error)>>Error was detected in the main line between the data link connector and the driver seat control unit.

NO >> Repair the main line between the harness connectors B69 and B54.

MAIN LINE BETWEEN ADP AND PWBD CIRCUIT

< DTC/CIRCUIT DIAGNOSIS >

[CAN SYSTEM (TYPE 4)]

MAIN LINE BETWEEN ADP AND PWBD CIRCUIT

Diagnosis Procedure

INFOID:000000008970536

1. CHECK HARNESS CONTINUITY (OPEN CIRCUIT)

1. Turn the ignition switch OFF.
2. Disconnect the battery cable from the negative terminal.
3. Disconnect the following harness connectors.
 - ECM (Models without around view monitor)
 - CAN gateway (Models with around view monitor)
 - Harness connector B54 and B200
 - Automatic back door control module
4. Check the continuity between the harness connector and the automatic back door control module harness connector.

Harness connector		Automatic back door control module harness connector		Continuity
Connector No.	Terminal No.	Connector No.	Terminal No.	
B54	1	B55	24	Existed
	2		12	Existed

Is the inspection result normal?

YES (Present error)>>Check CAN system type decision again.

YES (Past error)>>Error was detected in the main line between the driver seat control unit and the automatic back door control module.

NO >> Repair the main line between the harness connector B54 and the automatic back door control module.

A
B
C
D
E
F
G
H
I
J
K
L
N
O
P

LAN

MAIN LINE BETWEEN DLC AND CGW CIRCUIT

< DTC/CIRCUIT DIAGNOSIS >

[CAN SYSTEM (TYPE 4)]

MAIN LINE BETWEEN DLC AND CGW CIRCUIT

Diagnosis Procedure

INFOID:000000008970537

1. CHECK HARNESS CONTINUITY (OPEN CIRCUIT)

1. Turn the ignition switch OFF.
2. Disconnect the battery cable from the negative terminal.
3. Disconnect the following harness connectors.
 - ECM
 - CAN gateway
4. Check the continuity between the data link connector and the CAN gateway harness connector.

Data link connector		CAN gateway harness connector		Continuity
Connector No.	Terminal No.	Connector No.	Terminal No.	
M22	6	M5	1	Existed
	14		7	Existed

Is the inspection result normal?

YES (Present error)>>Check CAN system type decision again.

YES (Past error)>>Error was detected in the main line between the data link connector and the CAN gateway.

NO >> Repair the main line between the data link connector and the CAN gateway.

ECM BRANCH LINE CIRCUIT

< DTC/CIRCUIT DIAGNOSIS >

[CAN SYSTEM (TYPE 4)]

ECM BRANCH LINE CIRCUIT

Diagnosis Procedure

INFOID:000000008970538

1. CHECK CONNECTOR

1. Turn the ignition switch OFF.
2. Disconnect the battery cable from the negative terminal.
3. Check the terminals and connectors of the ECM for damage, bend and loose connection (unit side and connector side).

Is the inspection result normal?

- YES >> GO TO 2.
NO >> Repair the terminal and connector.

2. CHECK HARNESS FOR OPEN CIRCUIT

1. Disconnect the connector of ECM.
2. Check the resistance between the ECM harness connector terminals.

ECM harness connector			Resistance (Ω)
Connector No.	Terminal No.		
E16	114	113	Approx. 108 – 132

Is the measurement value within the specification?

- YES >> GO TO 3.
NO >> Repair the ECM branch line.

3. CHECK POWER SUPPLY AND GROUND CIRCUIT

Check the power supply and the ground circuit of the ECM. Refer to [EC-170. "Diagnosis Procedure"](#).

Is the inspection result normal?

- YES (Present error)>>Replace the ECM. Refer to [EC-460. "Removal and Installation"](#).
YES (Past error)>>Error was detected in the ECM branch line.
NO >> Repair the power supply and the ground circuit.

A
B
C
D
E
F
G
H
I
J
K
L

LAN

N
O
P

IPDM-E BRANCH LINE CIRCUIT

< DTC/CIRCUIT DIAGNOSIS >

[CAN SYSTEM (TYPE 4)]

IPDM-E BRANCH LINE CIRCUIT

Diagnosis Procedure

INFOID:000000008970539

1. CHECK CONNECTOR

1. Turn the ignition switch OFF.
2. Disconnect the battery cable from the negative terminal.
3. Check the terminals and connectors of the IPDM E/R for damage, bend and loose connection (unit side and connector side).

Is the inspection result normal?

- YES >> GO TO 2.
NO >> Repair the terminal and connector.

2. CHECK HARNESS FOR OPEN CIRCUIT

1. Disconnect the connector of IPDM E/R.
2. Check the resistance between the IPDM E/R harness connector terminals.

IPDM E/R harness connector			Resistance (Ω)
Connector No.	Terminal No.		
E119	29	28	Approx. 54 – 66

Is the measurement value within the specification?

- YES >> GO TO 3.
NO >> Repair the IPDM E/R branch line.

3. CHECK POWER SUPPLY AND GROUND CIRCUIT

Check the power supply and the ground circuit of the IPDM E/R. Refer to [PCS-31, "Diagnosis Procedure"](#).

Is the inspection result normal?

- YES (Present error)>>Replace the IPDM E/R. Refer to [PCS-32, "Removal and Installation"](#).
YES (Past error)>>Error was detected in the IPDM E/R branch line.
NO >> Repair the power supply and the ground circuit.

TCM BRANCH LINE CIRCUIT

< DTC/CIRCUIT DIAGNOSIS >

[CAN SYSTEM (TYPE 4)]

TCM BRANCH LINE CIRCUIT

Diagnosis Procedure

INFOID:000000008970540

1. CHECK CONNECTOR

1. Turn the ignition switch OFF.
2. Disconnect the battery cable from the negative terminal.
3. Check the following terminals and connectors for damage, bend and loose connection (unit side and connector side).
 - TCM
 - Harness connector F32
 - Harness connector E2

Is the inspection result normal?

- YES >> GO TO 2.
NO >> Repair the terminal and connector.

2. CHECK HARNESS FOR OPEN CIRCUIT

1. Disconnect the connector of TCM.
2. Check the resistance between the TCM harness connector terminals.

TCM harness connector		Resistance (Ω)
Connector No.	Terminal No.	
F15	33 23	Approx. 54 – 66

Is the measurement value within the specification?

- YES >> GO TO 3.
NO >> Repair the TCM branch line.

3. CHECK POWER SUPPLY AND GROUND CIRCUIT

Check the power supply and the ground circuit of the TCM. Refer to [TM-165, "Diagnosis Procedure"](#).

Is the inspection result normal?

- YES (Present error)>>Replace the TCM. Refer to [TM-197, "Removal and Installation"](#).
YES (Past error)>>Error was detected in the TCM branch line.
NO >> Repair the power supply and the ground circuit.

A
B
C
D
E
F
G
H
I
J
K
L

LAN

ABS BRANCH LINE CIRCUIT

< DTC/CIRCUIT DIAGNOSIS >

[CAN SYSTEM (TYPE 4)]

ABS BRANCH LINE CIRCUIT

Diagnosis Procedure

INFOID:000000008970541

1. CHECK CONNECTOR

1. Turn the ignition switch OFF.
2. Disconnect the battery cable from the negative terminal.
3. Check the terminals and connectors of the ABS actuator and electric unit (control unit) for damage, bend and loose connection (unit side and connector side).

Is the inspection result normal?

- YES >> GO TO 2.
NO >> Repair the terminal and connector.

2. CHECK HARNESS FOR OPEN CIRCUIT

1. Disconnect the connector of ABS actuator and electric unit (control unit).
2. Check the resistance between the ABS actuator and electric unit (control unit) harness connector terminals.

ABS actuator and electric unit (control unit) harness connector			Resistance (Ω)
Connector No.	Terminal No.		
E125	25	15	Approx. 54 – 66

Is the measurement value within the specification?

- YES >> GO TO 3.
NO >> Repair the ABS actuator and electric unit (control unit) branch line.

3. CHECK POWER SUPPLY AND GROUND CIRCUIT

Check the power supply and the ground circuit of the ABS actuator and electric unit (control unit). Refer to [BRC-63. "Diagnosis Procedure"](#).

Is the inspection result normal?

- YES (Present error)>>Replace the ABS actuator and electric unit (control unit). Refer to [BRC-121. "Removal and Installation"](#).
YES (Past error)>>Error was detected in the ABS actuator and electric unit (control unit) branch line.
NO >> Repair the power supply and the ground circuit.

EPS BRANCH LINE CIRCUIT

< DTC/CIRCUIT DIAGNOSIS >

[CAN SYSTEM (TYPE 4)]

EPS BRANCH LINE CIRCUIT

Diagnosis Procedure

INFOID:000000008970542

1. CHECK CONNECTOR

1. Turn the ignition switch OFF.
2. Disconnect the battery cable from the negative terminal.
3. Check the terminals and connectors of the power steering control module for damage, bend and loose connection (unit side and connector side).

Is the inspection result normal?

- YES >> GO TO 2.
NO >> Repair the terminal and connector.

2. CHECK HARNESS FOR OPEN CIRCUIT

1. Disconnect the connector of power steering control module.
2. Check the resistance between the power steering control module harness connector terminals.

Power steering control module harness connector			Resistance (Ω)
Connector No.	Terminal No.		
E62	8	7	Approx. 54 – 66

Is the measurement value within the specification?

- YES >> GO TO 3.
NO >> Repair the power steering control module branch line.

3. CHECK POWER SUPPLY AND GROUND CIRCUIT

Check the power supply and the ground circuit of the power steering control module. Refer to [STC-22, "Diagnosis Procedure"](#).

Is the inspection result normal?

- YES (Present error)>>Replace the power steering oil pump assembly. Refer to [ST-51, "Removal and Installation"](#).
YES (Past error)>>Error was detected in the power steering control module branch line.
NO >> Repair the power supply and the ground circuit.

A
B
C
D
E
F
G
H
I
J
K
L

LAN

A-BAG BRANCH LINE CIRCUIT

< DTC/CIRCUIT DIAGNOSIS >

[CAN SYSTEM (TYPE 4)]

A-BAG BRANCH LINE CIRCUIT

Diagnosis Procedure

INFOID:000000008970543

WARNING:

- Before servicing, turn ignition switch OFF, disconnect battery negative terminal, and wait 3 minutes or more. (To discharge backup capacitor.)
- Never use unspecified tester or other measuring device.

1.CHECK CONNECTOR

1. Turn the ignition switch OFF.
2. Disconnect the battery cable from the negative terminal.
3. Check the terminals and connectors of the air bag diagnosis sensor unit for damage, bend and loose connection (unit side and connector side).

Is the inspection result normal?

YES >> GO TO 2.

NO >> Replace the main harness.

2.CHECK AIR BAG DIAGNOSIS SENSOR UNIT

Check the air bag diagnosis sensor unit. Refer to [SRC-40, "Work Flow"](#).

Is the inspection result normal?

YES >> Replace the main harness.

NO >> Replace parts whose air bag system has a malfunction.

AV BRANCH LINE CIRCUIT

< DTC/CIRCUIT DIAGNOSIS >

[CAN SYSTEM (TYPE 4)]

AV BRANCH LINE CIRCUIT

Diagnosis Procedure

INFOID:000000008970544

1. CHECK CONNECTOR

1. Turn the ignition switch OFF.
2. Disconnect the battery cable from the negative terminal.
3. Check the terminals and connectors of the AV control unit for damage, bend and loose connection (unit side and connector side).

Is the inspection result normal?

- YES >> GO TO 2.
NO >> Repair the terminal and connector.

2. CHECK HARNESS FOR OPEN CIRCUIT

1. Disconnect the connector of AV control unit.
 2. Check the resistance between the AV control unit harness connector terminals.
- With BOSE audio without navigation

AV control unit harness connector			Resistance (Ω)
Connector No.	Terminal No.		
M42	11	12	Approx. 54 – 66

- Without BOSE audio with navigation

AV control unit harness connector			Resistance (Ω)
Connector No.	Terminal No.		
M124	11	12	Approx. 54 – 66

- With BOSE audio with navigation

AV control unit harness connector			Resistance (Ω)
Connector No.	Terminal No.		
M163	78	62	Approx. 54 – 66

Is the measurement value within the specification?

- YES >> GO TO 3.
NO >> Repair the AV control unit branch line.

3. CHECK POWER SUPPLY AND GROUND CIRCUIT

Check the power supply and the ground circuit of the AV control unit. Refer to the following.

- Mid audio without BOSE: [AV-143, "AV CONTROL UNIT : Diagnosis Procedure"](#)
- Mid audio with BOSE: [AV-303, "AV CONTROL UNIT : Diagnosis Procedure"](#)
- Premium audio with navigation: [AV-532, "AV CONTROL UNIT : Diagnosis Procedure"](#)

Is the inspection result normal?

YES (Present error)>>Replace the AV control unit. Refer to the following.

- Mid audio without BOSE: [AV-186, "Removal and Installation"](#)
- Mid audio with BOSE: [AV-357, "Removal and Installation"](#)
- Premium audio with navigation: [AV-585, "Removal and Installation"](#)

YES (Past error)>>Error was detected in the AV control unit branch line.

NO >> Repair the power supply and the ground circuit.

A
B
C
D
E
F
G
H
I
J
K
L
N
O
P

LAN

DLC BRANCH LINE CIRCUIT (CAN COMMUNICATION CIRCUIT 1)

< DTC/CIRCUIT DIAGNOSIS >

[CAN SYSTEM (TYPE 4)]

DLC BRANCH LINE CIRCUIT (CAN COMMUNICATION CIRCUIT 1)

Diagnosis Procedure

INFOID:000000008970546

1. CHECK CONNECTOR

1. Turn the ignition switch OFF.
2. Disconnect the battery cable from the negative terminal.
3. Check the terminals and connectors of the data link connector for damage, bend and loose connection (connector side and harness side).

Is the inspection result normal?

YES >> GO TO 2.

NO >> Repair the terminal and connector.

2. CHECK HARNESS FOR OPEN CIRCUIT

Check the resistance between the data link connector terminals.

Data link connector			Resistance (Ω)
Connector No.	Terminal No.		
M22	6	14	Approx. 54 – 66

Is the measurement value within the specification?

YES (Present error)>>Check CAN system type decision again.

YES (Past error)>>Error was detected in the data link connector branch line circuit (CAN communication circuit 1 side).

NO >> Repair the data link connector branch line (CAN communication circuit 1 side).

DLC BRANCH LINE CIRCUIT (CAN COMMUNICATION CIRCUIT 2)

< DTC/CIRCUIT DIAGNOSIS >

[CAN SYSTEM (TYPE 4)]

DLC BRANCH LINE CIRCUIT (CAN COMMUNICATION CIRCUIT 2)

Diagnosis Procedure

INFOID:000000008970547

1. CHECK CONNECTOR

1. Turn the ignition switch OFF.
2. Disconnect the battery cable from the negative terminal.
3. Check the terminals and connectors of the data link connector for damage, bend and loose connection (connector side and harness side).

Is the inspection result normal?

YES >> GO TO 2.

NO >> Repair the terminal and connector.

2. CHECK HARNESS FOR OPEN CIRCUIT

Check the resistance between the data link connector terminals.

Data link connector			Resistance (Ω)
Connector No.	Terminal No.		
M22	13	12	Approx. 54 – 66

Is the measurement value within the specification?

YES (Present error)>>Check CAN system type decision again.

YES (Past error)>>Error was detected in the data link connector branch line circuit (CAN communication circuit 2 side).

NO >> Repair the data link connector branch line (CAN communication circuit 2 side).

A
B
C
D
E
F
G
H
I
J
K
L

LAN

N
O
P

HVAC BRANCH LINE CIRCUIT

< DTC/CIRCUIT DIAGNOSIS >

[CAN SYSTEM (TYPE 4)]

HVAC BRANCH LINE CIRCUIT

Diagnosis Procedure

INFOID:000000008970548

1. CHECK CONNECTOR

1. Turn the ignition switch OFF.
2. Disconnect the battery cable from the negative terminal.
3. Check the terminals and connectors of the A/C auto amp. for damage, bend and loose connection (unit side and connector side).

Is the inspection result normal?

- YES >> GO TO 2.
NO >> Repair the terminal and connector.

2. CHECK HARNESS FOR OPEN CIRCUIT

1. Disconnect the connector of A/C auto amp.
2. Check the resistance between the A/C auto amp. harness connector terminals.

A/C auto amp. harness connector			Resistance (Ω)
Connector No.	Terminal No.		
M50	1	21	Approx. 54 – 66

Is the measurement value within the specification?

- YES >> GO TO 3.
NO >> Repair the A/C auto amp. branch line.

3. CHECK POWER SUPPLY AND GROUND CIRCUIT

Check the power supply and the ground circuit of the A/C auto amp. Refer to [HAC-113, "A/C AUTO AMP. : Diagnosis Procedure"](#).

Is the inspection result normal?

- YES (Present error)>>Replace the A/C auto amp. Refer to [HAC-156, "Removal and Installation"](#).
YES (Past error)>>Error was detected in the A/C auto amp. branch line.
NO >> Repair the power supply and the ground circuit.

M&A BRANCH LINE CIRCUIT

< DTC/CIRCUIT DIAGNOSIS >

[CAN SYSTEM (TYPE 4)]

M&A BRANCH LINE CIRCUIT

Diagnosis Procedure

INFOID:000000008970549

1. CHECK CONNECTOR

1. Turn the ignition switch OFF.
2. Disconnect the battery cable from the negative terminal.
3. Check the terminals and connectors of the combination meter for damage, bend and loose connection (unit side and connector side).

Is the inspection result normal?

- YES >> GO TO 2.
NO >> Repair the terminal and connector.

2. CHECK HARNESS FOR OPEN CIRCUIT

1. Disconnect the connector of combination meter.
2. Check the resistance between the combination meter harness connector terminals.

Combination meter harness connector			Resistance (Ω)
Connector No.	Terminal No.		
M24	39	38	Approx. 54 – 66

Is the measurement value within the specification?

- YES >> GO TO 3.
NO >> Repair the combination meter branch line.

3. CHECK POWER SUPPLY AND GROUND CIRCUIT

Check the power supply and the ground circuit of the combination meter. Refer to [MWI-59, "COMBINATION METER : Diagnosis Procedure"](#).

Is the inspection result normal?

- YES (Present error)>>Replace the combination meter. Refer to [MWI-82, "Removal and Installation"](#).
YES (Past error)>>Error was detected in the combination meter branch line.
NO >> Repair the power supply and the ground circuit.

A
B
C
D
E
F
G
H
I
J
K
L

LAN

N
O
P

SONAR BRANCH LINE CIRCUIT

< DTC/CIRCUIT DIAGNOSIS >

[CAN SYSTEM (TYPE 4)]

SONAR BRANCH LINE CIRCUIT

Diagnosis Procedure

INFOID:000000008970550

1. CHECK CONNECTOR

1. Turn the ignition switch OFF.
2. Disconnect the battery cable from the negative terminal.
3. Check the terminals and connectors of sonar control unit for damage, bend and loose connection (unit side and connector side).

Is the inspection result normal?

- YES >> GO TO 2.
NO >> Repair the terminal and connector.

2. CHECK HARNESS FOR OPEN CIRCUIT

1. Disconnect the connector of sonar control unit.
2. Check the resistance between the sonar control unit harness connector terminals.

Sonar control unit harness connector			Resistance (Ω)
Connector No.	Terminal No.		
M70	5	6	Approx. 54 – 66

Is the measurement value within the specification?

- YES >> GO TO 3.
NO >> Replace the main harness.

3. CHECK POWER SUPPLY AND GROUND CIRCUIT

Check the power supply and the ground circuit of the sonar control unit. Refer to [SN-32, "Diagnosis Procedure"](#).

Is the inspection result normal?

- YES (Present error)>>Replace the sonar control unit. Refer to [SN-34, "Removal and Installation"](#).
YES (Past error)>>Error was detected in the sonar control unit branch line.
NO >> Repair the power supply and the ground circuit.

STRG BRANCH LINE CIRCUIT

< DTC/CIRCUIT DIAGNOSIS >

[CAN SYSTEM (TYPE 4)]

STRG BRANCH LINE CIRCUIT

Diagnosis Procedure

INFOID:000000008970551

1. CHECK CONNECTOR

1. Turn the ignition switch OFF.
2. Disconnect the battery cable from the negative terminal.
3. Check the terminals and connectors of the steering angle sensor for damage, bend and loose connection (unit side and connector side).

Is the inspection result normal?

- YES >> GO TO 2.
NO >> Repair the terminal and connector.

2. CHECK HARNESS FOR OPEN CIRCUIT

1. Disconnect the connector of steering angle sensor.
2. Check the resistance between the steering angle sensor harness connector terminals.

Steering angle sensor harness connector			Resistance (Ω)
Connector No.	Terminal No.		
M54	5	2	Approx. 54 – 66

Is the measurement value within the specification?

- YES >> GO TO 3.
NO >> Repair the steering angle sensor branch line.

3. CHECK POWER SUPPLY AND GROUND CIRCUIT

Check the power supply and the ground circuit of the steering angle sensor. Refer to [BRC-44, "Wiring Diagram"](#).

Is the inspection result normal?

- YES (Present error)>>Replace the steering angle sensor. Refer to [BRC-124, "Removal and Installation"](#).
YES (Past error)>>Error was detected in the steering angle sensor branch line.
NO >> Repair the power supply and the ground circuit.

A
B
C
D
E
F
G
H
I
J
K
L

LAN

N
O
P

ADP BRANCH LINE CIRCUIT

< DTC/CIRCUIT DIAGNOSIS >

[CAN SYSTEM (TYPE 4)]

ADP BRANCH LINE CIRCUIT

Diagnosis Procedure

INFOID:000000008970552

1. CHECK CONNECTOR

1. Turn the ignition switch OFF.
2. Disconnect the battery cable from the negative terminal.
3. Check the following terminals and connectors for damage, bend and loose connection (unit side and connector side).
 - Driver seat control unit
 - Harness connector B200
 - Harness connector B54
 - CAN gateway (Models with around view monitor)

Is the inspection result normal?

- YES-1 >> Models with around view monitor: GO TO 2.
YES-2 >> Models without around view monitor: GO TO 3.
NO >> Repair the terminal and connector.

2. CHECK HARNESS CONTINUITY (OPEN CIRCUIT)

1. Disconnect the connector of CAN gateway.
2. Check the continuity between the CAN gateway harness connector terminals.

CAN gateway harness connector			Continuity
Connector No.	Terminal No.		
M5	4	6	Existed
	10	12	Existed

Is the inspection result normal?

- YES >> GO TO 3.
NO >> Check the harness and repair the root cause (CAN communication circuit 2 side).

3. CHECK HARNESS FOR OPEN CIRCUIT

1. Connect the connector of CAN gateway. (Models with around view monitor)
2. Disconnect the connector of driver seat control unit.
3. Check the resistance between the driver seat control unit harness connector terminals.

Driver seat control unit harness connector			Resistance (Ω)
Connector No.	Terminal No.		
B209	16	32	Approx. 54 – 66

Is the measurement value within the specification?

- YES >> GO TO 4.
NO >> Repair the driver seat control unit branch line.

4. CHECK POWER SUPPLY AND GROUND CIRCUIT

Check the power supply and the ground circuit of the driver seat control unit. Refer to [ADP-83, "DRIVER SEAT CONTROL UNIT : Diagnosis Procedure"](#).

Is the inspection result normal?

- YES (Present error)>>Replace the driver seat control unit. Refer to [ADP-156, "Removal and Installation"](#).
YES (Past error)>>Error was detected in the driver seat control unit branch line.
NO >> Repair the power supply and the ground circuit.

PWBD BRANCH LINE CIRCUIT

< DTC/CIRCUIT DIAGNOSIS >

[CAN SYSTEM (TYPE 4)]

PWBD BRANCH LINE CIRCUIT

Diagnosis Procedure

INFOID:000000008970554

1. CHECK CONNECTOR

1. Turn the ignition switch OFF.
2. Disconnect the battery cable from the negative terminal.
3. Check the following terminals and connectors for damage, bend and loose connection (unit side and connector side).
 - Automatic back door control module
 - CAN gateway (Models with around view monitor)

Is the inspection result normal?

- YES-1 >> Models with around view monitor: GO TO 2.
YES-2 >> Models without around view monitor: GO TO 3.
NO >> Repair the terminal and connector.

2. CHECK HARNESS CONTINUITY (OPEN CIRCUIT)

1. Disconnect the connector of CAN gateway.
2. Check the continuity between the CAN gateway harness connector terminals.

CAN gateway harness connector		Continuity	
Connector No.	Terminal No.		
M5	4	6	Existed
	10	12	Existed

Is the inspection result normal?

- YES >> GO TO 3.
NO >> Check the harness and repair the root cause (CAN communication circuit 2 side).

3. CHECK HARNESS FOR OPEN CIRCUIT

1. Connect the connector of CAN gateway. (Models with around view monitor)
2. Disconnect the connector of automatic back door control module.
3. Check the resistance between the automatic back door control module harness connector terminals.

Automatic back door control module harness connector		Resistance (Ω)	
Connector No.	Terminal No.		
B55	24	12	Approx. 54 – 66

Is the measurement value within the specification?

- YES >> GO TO 4.
NO >> Replace the body harness.

4. CHECK POWER SUPPLY AND GROUND CIRCUIT

Check the power supply and the ground circuit of the automatic back door control module. Refer to [DLK-160, "AUTOMATIC BACK DOOR CONTROL UNIT : Diagnosis Procedure"](#).

Is the inspection result normal?

- YES (Present error)>>Replace the automatic back door control module. Refer to [DLK-317, "Removal and Installation"](#).
YES (Past error)>>Error was detected in the automatic back door control module branch line.
NO >> Repair the power supply and the ground circuit.

A
B
C
D
E
F
G
H
I
J
K
L
N
O
P

LAN

BCM BRANCH LINE CIRCUIT

< DTC/CIRCUIT DIAGNOSIS >

[CAN SYSTEM (TYPE 4)]

BCM BRANCH LINE CIRCUIT

Diagnosis Procedure

INFOID:000000008970555

1. CHECK CONNECTOR

1. Turn the ignition switch OFF.
2. Disconnect the battery cable from the negative terminal.
3. Check the following terminals and connectors for damage, bend and loose connection (unit side and connector side).
 - BCM
 - Harness connector M84 (Models without around view monitor)
 - Harness connector B101 (Models without around view monitor)
 - Harness connector B124 (Models without around view monitor)
 - Harness connector B32 (Models without around view monitor)
 - Harness connector B69 (2WD models without automatic back door system)
 - Harness connector M40 (2WD models without automatic back door system)

Is the inspection result normal?

YES >> GO TO 2.

NO >> Repair the terminal and connector.

2. CHECK HARNESS FOR OPEN CIRCUIT

1. Disconnect the connector of BCM.
2. Check the resistance between the BCM harness connector terminals.

BCM harness connector			Resistance (Ω)
Connector No.	Terminal No.		
M19	60	59	Approx. 108 – 132

Is the measurement value within the specification?

YES >> GO TO 3.

NO >> Repair the BCM branch line.

3. CHECK POWER SUPPLY AND GROUND CIRCUIT

Check the power supply and the ground circuit of the BCM. Refer to [BCS-72, "Diagnosis Procedure"](#).

Is the inspection result normal?

YES (Present error)>>Replace the BCM. Refer to [BCS-78, "Removal and Installation"](#).

YES (Past error)>>Error was detected in the BCM branch line.

NO >> Repair the power supply and the ground circuit.

CGW BRANCH LINE CIRCUIT (CAN COMMUNICATION CIRCUIT 1)

< DTC/CIRCUIT DIAGNOSIS >

[CAN SYSTEM (TYPE 4)]

CGW BRANCH LINE CIRCUIT (CAN COMMUNICATION CIRCUIT 1)

Diagnosis Procedure

INFOID:000000008970556

1. CHECK DTC

Check DTC of the CAN gateway with CONSULT.

Is U1010 or B2600 indicated?

YES >> Perform a diagnosis of the indicated DTC.

NO >> GO TO 2.

2. CHECK CONNECTOR

1. Turn the ignition switch OFF.
2. Disconnect the battery cable from the negative terminal.
3. Check the terminals and connectors of the CAN gateway for damage, bend and loose connection (unit side and connector side).

Is the inspection result normal?

YES >> GO TO 3.

NO >> Repair the terminal and connector.

3. CHECK HARNESS FOR OPEN CIRCUIT

1. Disconnect the connector of CAN gateway.
2. Check the resistance between the CAN gateway harness connector terminals.

CAN gateway harness connector			Resistance (Ω)
Connector No.	Terminal No.		
M5	1	7	Approx. 54 – 66

Is the measurement value within the specification?

YES >> GO TO 4.

NO >> Repair the CAN gateway branch line (CAN communication circuit 1 side).

4. CHECK POWER SUPPLY AND GROUND CIRCUIT

Check the power supply and the ground circuit of the CAN gateway. Refer to [LAN-107. "Diagnosis Procedure"](#).

Is the inspection result normal?

YES (Present error)>>Replace the CAN gateway. Refer to [LAN-108. "Removal and Installation"](#).

YES (Past error)>>Error was detected in the CAN gateway branch line (CAN communication circuit 1 side).

NO >> Repair the power supply and the ground circuit.

LAN

CGW BRANCH LINE CIRCUIT (CAN COMMUNICATION CIRCUIT 2)

< DTC/CIRCUIT DIAGNOSIS >

[CAN SYSTEM (TYPE 4)]

CGW BRANCH LINE CIRCUIT (CAN COMMUNICATION CIRCUIT 2)

Diagnosis Procedure

INFOID:000000008970557

1. CHECK DTC

Check DTC of the CAN gateway with CONSULT.

Is U1010 or B2600 indicated?

- YES >> Perform a diagnosis of the indicated DTC.
- NO >> GO TO 2.

2. CHECK CONNECTOR

1. Turn the ignition switch OFF.
2. Disconnect the battery cable from the negative terminal.
3. Check the following terminals and connectors of the CAN gateway for damage, bend and loose connection (unit side and connector side).

Is the inspection result normal?

- YES >> GO TO 3.
- NO >> Repair the terminal and connector.

3. CHECK HARNESS CONTINUITY (OPEN CIRCUIT)

1. Disconnect the connector of CAN gateway.
2. Check the continuity between the CAN gateway harness connector terminals.

CAN gateway harness connector			Continuity
Connector No.	Terminal No.		
M5	4	6	Existed
	10	12	Existed

Is the inspection result normal?

- YES >> GO TO 4.
- NO >> Repair the CAN gateway branch line (CAN communication circuit 2 side).

4. CHECK POWER SUPPLY AND GROUND CIRCUIT

Check the power supply and the ground circuit of the CAN gateway. Refer to [LAN-107, "Diagnosis Procedure"](#).

Is the inspection result normal?

- YES (Present error)>>Replace the CAN gateway. Refer to [LAN-108, "Removal and Installation"](#).
- YES (Past error)>>Error was detected in the CAN gateway branch line (CAN communication circuit 2 side).
- NO >> Repair the power supply and the ground circuit.

AVM BRANCH LINE CIRCUIT

< DTC/CIRCUIT DIAGNOSIS >

[CAN SYSTEM (TYPE 4)]

AVM BRANCH LINE CIRCUIT

Diagnosis Procedure

INFOID:000000008970558

1. CHECK CONNECTOR

1. Turn the ignition switch OFF.
2. Disconnect the battery cable from the negative terminal.
3. Check the following terminals and connectors for damage, bend and loose connection (unit side and connector side).
 - Around view monitor control unit
 - CAN gateway

Is the inspection result normal?

- YES >> GO TO 2.
NO >> Repair the terminal and connector.

2. CHECK HARNESS CONTINUITY (OPEN CIRCUIT)

1. Disconnect the connector of CAN gateway.
2. Check the continuity between the CAN gateway harness connector terminals.

CAN gateway harness connector		Continuity	
Connector No.	Terminal No.		
M5	4	6	Existed
	10	12	Existed

Is the inspection result normal?

- YES >> GO TO 3.
NO >> Check the harness and repair the root cause (CAN communication circuit 2 side).

3. CHECK HARNESS FOR OPEN CIRCUIT

1. Connect the connector of CAN gateway.
2. Disconnect the connector of around view monitor control unit.
3. Check the resistance between the around view monitor control unit harness connector terminals.

Around view monitor control unit harness connector		Resistance (Ω)	
Connector No.	Terminal No.		
M96	12	10	Approx. 54 – 66

Is the measurement value within the specification?

- YES >> GO TO 4.
NO >> Replace the main harness.

4. CHECK POWER SUPPLY AND GROUND CIRCUIT

Check the power supply and the ground circuit of the around view monitor control unit. Refer to [AV-537, "AROUND VIEW MONITOR CONTROL UNIT : Diagnosis Procedure"](#).

Is the inspection result normal?

- YES (Present error)>>Replace the around view monitor control unit. Refer to [AV-603, "Removal and Installation"](#).
YES (Past error)>>Error was detected in the around view monitor control unit branch line.
NO >> Repair the power supply and the ground circuit.

A
B
C
D
E
F
G
H
I
J
K
L
LAN
N
O
P

CAN COMMUNICATION CIRCUIT 1

< DTC/CIRCUIT DIAGNOSIS >

[CAN SYSTEM (TYPE 4)]

CAN COMMUNICATION CIRCUIT 1

Diagnosis Procedure

INFOID:000000008970560

1.CONNECTOR INSPECTION

1. Turn the ignition switch OFF.
2. Disconnect the battery cable from the negative terminal.
3. Disconnect all the unit connectors on CAN communication circuit 1.
4. Check terminals and connectors for damage, bend and loose connection.

Is the inspection result normal?

- YES >> GO TO 2.
NO >> Repair the terminal and connector.

2.CHECK HARNESS CONTINUITY (SHORT CIRCUIT)

Check the continuity between the data link connector terminals.

Data link connector		Continuity
Connector No.	Terminal No.	
M22	6 14	Not existed

Is the inspection result normal?

- YES >> GO TO 3.
NO >> Check the harness and repair the root cause.

3.CHECK HARNESS CONTINUITY (SHORT CIRCUIT)

Check the continuity between the data link connector and the ground.

Data link connector		Ground	Continuity
Connector No.	Terminal No.		
M22	6		Not existed
	14		Not existed

Is the inspection result normal?

- YES >> GO TO 4.
NO >> Check the harness and repair the root cause.

4.CHECK ECM AND BCM TERMINATION CIRCUIT

1. Remove the ECM and the BCM.
2. Check the resistance between the ECM terminals.

ECM		Resistance (Ω)
Terminal No.		
114	113	Approx. 108 – 132

3. Check the resistance between the BCM terminals.

BCM		Resistance (Ω)
Terminal No.		
60	59	Approx. 108 – 132

Is the measurement value within the specification?

- YES >> GO TO 5.
NO >> Replace the ECM and/or the BCM.

5.CHECK SYMPTOM

Connect all the connectors. Check if the symptoms described in the “Symptom (Results from interview with customer)” are reproduced.

CAN COMMUNICATION CIRCUIT 1

< DTC/CIRCUIT DIAGNOSIS >

[CAN SYSTEM (TYPE 4)]

Inspection result

Reproduced>>GO TO 6.

Non-reproduced>>Start the diagnosis again. Follow the trouble diagnosis procedure when past error is detected.

6.CHECK UNIT REPRODUCTION

Perform the reproduction test as per the following procedure for each unit.

1. Turn the ignition switch OFF.
2. Disconnect the battery cable from the negative terminal.
3. Disconnect one of the unit connectors of CAN communication circuit 1.

NOTE:

ECM and BCM have a termination circuit. Check other units first.

4. Connect the battery cable to the negative terminal. Check if the symptoms described in the “Symptom (Results from interview with customer)” are reproduced.

NOTE:

Although unit-related error symptoms occur, do not confuse them with other symptoms.

Inspection result

Reproduced>>Connect the connector. Check other units as per the above procedure.

Non-reproduced>>Replace the unit whose connector was disconnected.

A
B
C
D
E
F
G
H
I
J
K
L
N
O
P

LAN

CAN COMMUNICATION CIRCUIT 2

< DTC/CIRCUIT DIAGNOSIS >

[CAN SYSTEM (TYPE 4)]

CAN COMMUNICATION CIRCUIT 2

Diagnosis Procedure

INFOID:000000008970561

1.CONNECTOR INSPECTION

1. Turn the ignition switch OFF.
2. Disconnect the battery cable from the negative terminal.
3. Disconnect all the unit connectors on CAN communication circuit 2.
4. Check terminals and connectors for damage, bend and loose connection.

Is the inspection result normal?

- YES >> GO TO 2.
NO >> Repair the terminal and connector.

2.CHECK HARNESS CONTINUITY (SHORT CIRCUIT)

Check the continuity between the data link connector terminals.

Data link connector		Continuity
Connector No.	Terminal No.	
M22	13	Not existed
	12	

Is the inspection result normal?

- YES >> GO TO 3.
NO >> Check the harness and repair the root cause.

3.CHECK HARNESS CONTINUITY (SHORT CIRCUIT)

Check the continuity between the data link connector and the ground.

Data link connector		Ground	Continuity
Connector No.	Terminal No.		
M22	13		Not existed
	12		Not existed

Is the inspection result normal?

- YES >> GO TO 4.
NO >> Check the harness and repair the root cause.

4.CHECK CAN GATEWAY TERMINATION CIRCUIT

1. Remove the CAN gateway.
2. Check the resistance between the CAN gateway terminals.

CAN gateway		Resistance (Ω)
Terminal No.		
4	10	Approx. 108 – 132
6	12	Approx. 108 – 132

Is the measurement value within the specification?

- YES >> GO TO 5.
NO >> Replace the CAN gateway.

5.CHECK SYMPTOM

Connect all the connectors. Check if the symptoms described in the “Symptom (Results from interview with customer)” are reproduced.

Inspection result

- Reproduced>>GO TO 6.
Non-reproduced>>Start the diagnosis again. Follow the trouble diagnosis procedure when past error is detected.

CAN COMMUNICATION CIRCUIT 2

< DTC/CIRCUIT DIAGNOSIS >

[CAN SYSTEM (TYPE 4)]

6. CHECK UNIT REPRODUCTION

Perform the reproduction test as per the following procedure for each unit.

1. Turn the ignition switch OFF.
2. Disconnect the battery cable from the negative terminal.
3. Disconnect one of the unit connectors of CAN communication circuit 2.

NOTE:

CAN gateway has two termination circuits. Check other units first.

4. Connect the battery cable to the negative terminal. Check if the symptoms described in the “Symptom (Results from interview with customer)” are reproduced.

NOTE:

Although unit-related error symptoms occur, do not confuse them with other symptoms.

Inspection result

Reproduced>>Connect the connector. Check other units as per the above procedure.

Non-reproduced>>Replace the unit whose connector was disconnected.

A

B

C

D

E

F

G

H

I

J

K

L

LAN

N

O

P

MAIN LINE BETWEEN IPDM-E AND ABS CIRCUIT

< DTC/CIRCUIT DIAGNOSIS >

[CAN SYSTEM (TYPE 5)]

DTC/CIRCUIT DIAGNOSIS

MAIN LINE BETWEEN IPDM-E AND ABS CIRCUIT

Diagnosis Procedure

INFOID:000000008970562

1. CHECK HARNESS CONTINUITY (OPEN CIRCUIT)

1. Turn the ignition switch OFF.
2. Disconnect the battery cable from the negative terminal.
3. Disconnect the following harness connectors.
 - ECM
 - IPDM E/R
 - ABS actuator and electric unit (control unit)
4. Check the continuity between the IPDM E/R harness connector and the ABS actuator and electric unit (control unit) harness connector.

IPDM E/R harness connector		ABS actuator and electric unit (control unit) harness connector		Continuity
Connector No.	Terminal No.	Connector No.	Terminal No.	
E119	29	E125	25	Existed
	28		15	Existed

Is the inspection result normal?

YES (Present error)>>Check CAN system type decision again.

YES (Past error)>>Error was detected in the main line between the IPDM E/R and the ABS actuator and electric unit (control unit).

NO >> Repair the main line between the IPDM E/R and the ABS actuator and electric unit (control unit).

MAIN LINE BETWEEN ABS AND DLC CIRCUIT

< DTC/CIRCUIT DIAGNOSIS >

[CAN SYSTEM (TYPE 5)]

MAIN LINE BETWEEN ABS AND DLC CIRCUIT

Diagnosis Procedure

INFOID:000000008970563

1. CHECK CONNECTOR

1. Turn the ignition switch OFF.
2. Disconnect the battery cable from the negative terminal.
3. Check the following terminals and connectors for damage, bend and loose connection (connector side and harness side).
 - Harness connector E152
 - Harness connector M31

Is the inspection result normal?

YES >> GO TO 2.

NO >> Repair the terminal and connector.

2. CHECK HARNESS CONTINUITY (OPEN CIRCUIT)

1. Disconnect the following harness connectors.
 - ABS actuator and electric unit (control unit)
 - Harness connectors E152 and M31.
2. Check the continuity between the ABS actuator and electric unit (control unit) harness connector and the harness connector.

ABS actuator and electric unit (control unit) harness connector		Harness connector		Continuity
Connector No.	Terminal No.	Connector No.	Terminal No.	
E125	25	E152	36G	Existed
	15		35G	Existed

Is the inspection result normal?

YES >> GO TO 3.

NO >> Repair the main line between the ABS actuator and electric unit (control unit) and the harness connector E152.

3. CHECK HARNESS CONTINUITY (OPEN CIRCUIT)

Check the continuity between the harness connector and the data link connector.

Harness connector		Data link connector		Continuity
Connector No.	Terminal No.	Connector No.	Terminal No.	
M31	36G	M22	6	Existed
	35G		14	Existed

Is the inspection result normal?

YES (Present error)>>Check CAN system type decision again.

YES (Past error)>>Error was detected in the main line between the ABS actuator and electric unit (control unit) and the data link connector.

NO >> Repair the main line between the harness connector M31 and the data link connector.

A
B
C
D
E
F
G
H
I
J
K
L
LAN
N
O
P

MAIN LINE BETWEEN DLC AND 4WD CIRCUIT

< DTC/CIRCUIT DIAGNOSIS >

[CAN SYSTEM (TYPE 5)]

MAIN LINE BETWEEN DLC AND 4WD CIRCUIT

Diagnosis Procedure

INFOID:000000008970594

1. CHECK CONNECTOR

1. Turn the ignition switch OFF.
2. Disconnect the battery cable from the negative terminal.
3. Check the following terminals and connectors for damage, bend and loose connection (connector side and harness side).
 - Harness connector M40
 - Harness connector B69

Is the inspection result normal?

YES >> GO TO 2.

NO >> Repair the terminal and connector.

2. CHECK HARNESS CONTINUITY (OPEN CIRCUIT)

1. Disconnect the harness connectors M40 and B69.
2. Check the continuity between the data link connector and the harness connector.

Data link connector		Harness connector		Continuity
Connector No.	Terminal No.	Connector No.	Terminal No.	
M22	6	M40	89A	Existed
	14		90A	Existed

Is the inspection result normal?

YES >> GO TO 3.

NO >> Repair the main line between the data link connector and the harness connector M40.

3. CHECK HARNESS CONTINUITY (OPEN CIRCUIT)

1. Disconnect the connector of 4WD control unit.
2. Check the continuity between the harness connector and the 4WD control unit harness connector.

Harness connector		4WD control unit harness connector		Continuity
Connector No.	Terminal No.	Connector No.	Terminal No.	
B69	89A	B67	8	Existed
	90A		16	Existed

Is the inspection result normal?

YES (Present error)>>Check CAN system type decision again.

YES (Past error)>>Error was detected in the main line between the data link connector and the 4WD control unit.

NO >> Repair the main line between the harness connector B69 and the 4WD control unit.

ECM BRANCH LINE CIRCUIT

< DTC/CIRCUIT DIAGNOSIS >

[CAN SYSTEM (TYPE 5)]

ECM BRANCH LINE CIRCUIT

Diagnosis Procedure

INFOID:000000008970570

1. CHECK CONNECTOR

1. Turn the ignition switch OFF.
2. Disconnect the battery cable from the negative terminal.
3. Check the terminals and connectors of the ECM for damage, bend and loose connection (unit side and connector side).

Is the inspection result normal?

- YES >> GO TO 2.
NO >> Repair the terminal and connector.

2. CHECK HARNESS FOR OPEN CIRCUIT

1. Disconnect the connector of ECM.
2. Check the resistance between the ECM harness connector terminals.

ECM harness connector			Resistance (Ω)
Connector No.	Terminal No.		
E16	114	113	Approx. 108 – 132

Is the measurement value within the specification?

- YES >> GO TO 3.
NO >> Repair the ECM branch line.

3. CHECK POWER SUPPLY AND GROUND CIRCUIT

Check the power supply and the ground circuit of the ECM. Refer to [EC-170. "Diagnosis Procedure"](#).

Is the inspection result normal?

- YES (Present error)>>Replace the ECM. Refer to [EC-460. "Removal and Installation"](#).
YES (Past error)>>Error was detected in the ECM branch line.
NO >> Repair the power supply and the ground circuit.

A
B
C
D
E
F
G
H
I
J
K
L

LAN

N
O
P

IPDM-E BRANCH LINE CIRCUIT

< DTC/CIRCUIT DIAGNOSIS >

[CAN SYSTEM (TYPE 5)]

IPDM-E BRANCH LINE CIRCUIT

Diagnosis Procedure

INFOID:000000008970571

1. CHECK CONNECTOR

1. Turn the ignition switch OFF.
2. Disconnect the battery cable from the negative terminal.
3. Check the terminals and connectors of the IPDM E/R for damage, bend and loose connection (unit side and connector side).

Is the inspection result normal?

- YES >> GO TO 2.
NO >> Repair the terminal and connector.

2. CHECK HARNESS FOR OPEN CIRCUIT

1. Disconnect the connector of IPDM E/R.
2. Check the resistance between the IPDM E/R harness connector terminals.

IPDM E/R harness connector			Resistance (Ω)
Connector No.	Terminal No.		
E119	29	28	Approx. 54 – 66

Is the measurement value within the specification?

- YES >> GO TO 3.
NO >> Repair the IPDM E/R branch line.

3. CHECK POWER SUPPLY AND GROUND CIRCUIT

Check the power supply and the ground circuit of the IPDM E/R. Refer to [PCS-31, "Diagnosis Procedure"](#).

Is the inspection result normal?

- YES (Present error)>>Replace the IPDM E/R. Refer to [PCS-32, "Removal and Installation"](#).
YES (Past error)>>Error was detected in the IPDM E/R branch line.
NO >> Repair the power supply and the ground circuit.

TCM BRANCH LINE CIRCUIT

< DTC/CIRCUIT DIAGNOSIS >

[CAN SYSTEM (TYPE 5)]

TCM BRANCH LINE CIRCUIT

Diagnosis Procedure

INFOID:000000008970572

1. CHECK CONNECTOR

1. Turn the ignition switch OFF.
2. Disconnect the battery cable from the negative terminal.
3. Check the following terminals and connectors for damage, bend and loose connection (unit side and connector side).
 - TCM
 - Harness connector F32
 - Harness connector E2

Is the inspection result normal?

- YES >> GO TO 2.
NO >> Repair the terminal and connector.

2. CHECK HARNESS FOR OPEN CIRCUIT

1. Disconnect the connector of TCM.
2. Check the resistance between the TCM harness connector terminals.

TCM harness connector		Resistance (Ω)
Connector No.	Terminal No.	
F15	33 23	Approx. 54 – 66

Is the measurement value within the specification?

- YES >> GO TO 3.
NO >> Repair the TCM branch line.

3. CHECK POWER SUPPLY AND GROUND CIRCUIT

Check the power supply and the ground circuit of the TCM. Refer to [TM-165, "Diagnosis Procedure"](#).

Is the inspection result normal?

- YES (Present error)>>Replace the TCM. Refer to [TM-197, "Removal and Installation"](#).
YES (Past error)>>Error was detected in the TCM branch line.
NO >> Repair the power supply and the ground circuit.

A
B
C
D
E
F
G
H
I
J
K
L

LAN

ABS BRANCH LINE CIRCUIT

< DTC/CIRCUIT DIAGNOSIS >

[CAN SYSTEM (TYPE 5)]

ABS BRANCH LINE CIRCUIT

Diagnosis Procedure

INFOID:000000008970573

1. CHECK CONNECTOR

1. Turn the ignition switch OFF.
2. Disconnect the battery cable from the negative terminal.
3. Check the terminals and connectors of the ABS actuator and electric unit (control unit) for damage, bend and loose connection (unit side and connector side).

Is the inspection result normal?

- YES >> GO TO 2.
NO >> Repair the terminal and connector.

2. CHECK HARNESS FOR OPEN CIRCUIT

1. Disconnect the connector of ABS actuator and electric unit (control unit).
2. Check the resistance between the ABS actuator and electric unit (control unit) harness connector terminals.

ABS actuator and electric unit (control unit) harness connector			Resistance (Ω)
Connector No.	Terminal No.		
E125	25	15	Approx. 54 – 66

Is the measurement value within the specification?

- YES >> GO TO 3.
NO >> Repair the ABS actuator and electric unit (control unit) branch line.

3. CHECK POWER SUPPLY AND GROUND CIRCUIT

Check the power supply and the ground circuit of the ABS actuator and electric unit (control unit). Refer to [BRC-63. "Diagnosis Procedure"](#).

Is the inspection result normal?

- YES (Present error)>>Replace the ABS actuator and electric unit (control unit). Refer to [BRC-121. "Removal and Installation"](#).
YES (Past error)>>Error was detected in the ABS actuator and electric unit (control unit) branch line.
NO >> Repair the power supply and the ground circuit.

EPS BRANCH LINE CIRCUIT

< DTC/CIRCUIT DIAGNOSIS >

[CAN SYSTEM (TYPE 5)]

EPS BRANCH LINE CIRCUIT

Diagnosis Procedure

INFOID:000000008970574

1. CHECK CONNECTOR

1. Turn the ignition switch OFF.
2. Disconnect the battery cable from the negative terminal.
3. Check the terminals and connectors of the power steering control module for damage, bend and loose connection (unit side and connector side).

Is the inspection result normal?

- YES >> GO TO 2.
NO >> Repair the terminal and connector.

2. CHECK HARNESS FOR OPEN CIRCUIT

1. Disconnect the connector of power steering control module.
2. Check the resistance between the power steering control module harness connector terminals.

Power steering control module harness connector			Resistance (Ω)
Connector No.	Terminal No.		
E62	8	7	Approx. 54 – 66

Is the measurement value within the specification?

- YES >> GO TO 3.
NO >> Repair the power steering control module branch line.

3. CHECK POWER SUPPLY AND GROUND CIRCUIT

Check the power supply and the ground circuit of the power steering control module. Refer to [STC-22, "Diagnosis Procedure"](#).

Is the inspection result normal?

- YES (Present error)>>Replace the power steering oil pump assembly. Refer to [ST-51, "Removal and Installation"](#).
YES (Past error)>>Error was detected in the power steering control module branch line.
NO >> Repair the power supply and the ground circuit.

LAN

A-BAG BRANCH LINE CIRCUIT

< DTC/CIRCUIT DIAGNOSIS >

[CAN SYSTEM (TYPE 5)]

A-BAG BRANCH LINE CIRCUIT

Diagnosis Procedure

INFOID:000000008970575

WARNING:

- Before servicing, turn ignition switch OFF, disconnect battery negative terminal, and wait 3 minutes or more. (To discharge backup capacitor.)
- Never use unspecified tester or other measuring device.

1. CHECK CONNECTOR

1. Turn the ignition switch OFF.
2. Disconnect the battery cable from the negative terminal.
3. Check the terminals and connectors of the air bag diagnosis sensor unit for damage, bend and loose connection (unit side and connector side).

Is the inspection result normal?

- YES >> GO TO 2.
NO >> Replace the main harness.

2. CHECK AIR BAG DIAGNOSIS SENSOR UNIT

Check the air bag diagnosis sensor unit. Refer to [SRC-40, "Work Flow"](#).

Is the inspection result normal?

- YES >> Replace the main harness.
NO >> Replace parts whose air bag system has a malfunction.

DLC BRANCH LINE CIRCUIT

< DTC/CIRCUIT DIAGNOSIS >

[CAN SYSTEM (TYPE 5)]

DLC BRANCH LINE CIRCUIT

Diagnosis Procedure

INFOID:000000008970577

1. CHECK CONNECTOR

1. Turn the ignition switch OFF.
2. Disconnect the battery cable from the negative terminal.
3. Check the terminals and connectors of the data link connector for damage, bend and loose connection (connector side and harness side).

Is the inspection result normal?

- YES >> GO TO 2.
NO >> Repair the terminal and connector.

2. CHECK HARNESS FOR OPEN CIRCUIT

Check the resistance between the data link connector terminals.

Data link connector			Resistance (Ω)
Connector No.	Terminal No.		
M22	6	14	Approx. 54 – 66

Is the measurement value within the specification?

- YES (Present error)>>Check CAN system type decision again.
YES (Past error)>>Error was detected in the data link connector branch line circuit.
NO >> Repair the data link connector branch line.

A
B
C
D
E
F
G
H
I
J
K
L

LAN

N
O
P

HVAC BRANCH LINE CIRCUIT

< DTC/CIRCUIT DIAGNOSIS >

[CAN SYSTEM (TYPE 5)]

HVAC BRANCH LINE CIRCUIT

Diagnosis Procedure

INFOID:000000008970580

1. CHECK CONNECTOR

1. Turn the ignition switch OFF.
2. Disconnect the battery cable from the negative terminal.
3. Check the terminals and connectors of the A/C auto amp. for damage, bend and loose connection (unit side and connector side).

Is the inspection result normal?

- YES >> GO TO 2.
NO >> Repair the terminal and connector.

2. CHECK HARNESS FOR OPEN CIRCUIT

1. Disconnect the connector of A/C auto amp.
2. Check the resistance between the A/C auto amp. harness connector terminals.

A/C auto amp. harness connector			Resistance (Ω)
Connector No.	Terminal No.		
M50	1	21	Approx. 54 – 66

Is the measurement value within the specification?

- YES >> GO TO 3.
NO >> Repair the A/C auto amp. branch line.

3. CHECK POWER SUPPLY AND GROUND CIRCUIT

Check the power supply and the ground circuit of the A/C auto amp. Refer to [HAC-113, "A/C AUTO AMP. : Diagnosis Procedure"](#).

Is the inspection result normal?

- YES (Present error)>>Replace the A/C auto amp. Refer to [HAC-156, "Removal and Installation"](#).
YES (Past error)>>Error was detected in the A/C auto amp. branch line.
NO >> Repair the power supply and the ground circuit.

M&A BRANCH LINE CIRCUIT

< DTC/CIRCUIT DIAGNOSIS >

[CAN SYSTEM (TYPE 5)]

M&A BRANCH LINE CIRCUIT

Diagnosis Procedure

INFOID:000000008970581

1. CHECK CONNECTOR

1. Turn the ignition switch OFF.
2. Disconnect the battery cable from the negative terminal.
3. Check the terminals and connectors of the combination meter for damage, bend and loose connection (unit side and connector side).

Is the inspection result normal?

- YES >> GO TO 2.
NO >> Repair the terminal and connector.

2. CHECK HARNESS FOR OPEN CIRCUIT

1. Disconnect the connector of combination meter.
2. Check the resistance between the combination meter harness connector terminals.

Combination meter harness connector			Resistance (Ω)
Connector No.	Terminal No.		
M24	39	38	Approx. 54 – 66

Is the measurement value within the specification?

- YES >> GO TO 3.
NO >> Repair the combination meter branch line.

3. CHECK POWER SUPPLY AND GROUND CIRCUIT

Check the power supply and the ground circuit of the combination meter. Refer to [MWI-59, "COMBINATION METER : Diagnosis Procedure"](#).

Is the inspection result normal?

- YES (Present error)>>Replace the combination meter. Refer to [MWI-82, "Removal and Installation"](#).
YES (Past error)>>Error was detected in the combination meter branch line.
NO >> Repair the power supply and the ground circuit.

A
B
C
D
E
F
G
H
I
J
K
L

LAN

STRG BRANCH LINE CIRCUIT

< DTC/CIRCUIT DIAGNOSIS >

[CAN SYSTEM (TYPE 5)]

STRG BRANCH LINE CIRCUIT

Diagnosis Procedure

INFOID:000000008970583

1. CHECK CONNECTOR

1. Turn the ignition switch OFF.
2. Disconnect the battery cable from the negative terminal.
3. Check the terminals and connectors of the steering angle sensor for damage, bend and loose connection (unit side and connector side).

Is the inspection result normal?

- YES >> GO TO 2.
NO >> Repair the terminal and connector.

2. CHECK HARNESS FOR OPEN CIRCUIT

1. Disconnect the connector of steering angle sensor.
2. Check the resistance between the steering angle sensor harness connector terminals.

Steering angle sensor harness connector			Resistance (Ω)
Connector No.	Terminal No.		
M54	5	2	Approx. 54 – 66

Is the measurement value within the specification?

- YES >> GO TO 3.
NO >> Repair the steering angle sensor branch line.

3. CHECK POWER SUPPLY AND GROUND CIRCUIT

Check the power supply and the ground circuit of the steering angle sensor. Refer to [BRC-44, "Wiring Diagram"](#).

Is the inspection result normal?

- YES (Present error)>>Replace the steering angle sensor. Refer to [BRC-124, "Removal and Installation"](#).
YES (Past error)>>Error was detected in the steering angle sensor branch line.
NO >> Repair the power supply and the ground circuit.

4WD BRANCH LINE CIRCUIT

< DTC/CIRCUIT DIAGNOSIS >

[CAN SYSTEM (TYPE 5)]

4WD BRANCH LINE CIRCUIT

Diagnosis Procedure

INFOID:000000008970585

1. CHECK CONNECTOR

1. Turn the ignition switch OFF.
2. Disconnect the battery cable from the negative terminal.
3. Check the following terminals and connectors for damage, bend and loose connection (unit side and connector side).
 - 4WD control unit
 - CAN gateway (Models with around view monitor)

Is the inspection result normal?

- YES-1 >> Models with around view monitor: GO TO 2.
YES-2 >> Models without around view monitor: GO TO 3.
NO >> Repair the terminal and connector.

2. CHECK HARNESS CONTINUITY (OPEN CIRCUIT)

1. Disconnect the connector of CAN gateway.
2. Check the continuity between the CAN gateway harness connector terminals.

CAN gateway harness connector		Continuity	
Connector No.	Terminal No.		
M5	4	6	Existed
	10	12	Existed

Is the inspection result normal?

- YES >> GO TO 3.
NO >> Check the harness and repair the root cause (CAN communication circuit 2 side).

3. CHECK HARNESS FOR OPEN CIRCUIT

1. Connect the connector of CAN gateway. (Models with around view monitor)
2. Disconnect the connector of 4WD control unit.
3. Check the resistance between the 4WD control unit harness connector terminals.

4WD control unit harness connector		Resistance (Ω)	
Connector No.	Terminal No.		
B67	8	16	Approx. 54 – 66

Is the measurement value within the specification?

- YES >> GO TO 4.
NO >> Repair the 4WD control unit branch line.

4. CHECK POWER SUPPLY AND GROUND CIRCUIT

Check the power supply and the ground circuit of the 4WD control unit. Refer to [DLN-59, "Diagnosis Procedure"](#).

Is the inspection result normal?

- YES (Present error)>>Replace the 4WD control unit. Refer to [DLN-71, "Removal and Installation"](#).
YES (Past error)>>Error was detected in the 4WD control unit branch line.
NO >> Repair the power supply and the ground circuit.

A
B
C
D
E
F
G
H
I
J
K
L
N
O
P

LAN

BCM BRANCH LINE CIRCUIT

< DTC/CIRCUIT DIAGNOSIS >

[CAN SYSTEM (TYPE 5)]

BCM BRANCH LINE CIRCUIT

Diagnosis Procedure

INFOID:000000008970587

1. CHECK CONNECTOR

1. Turn the ignition switch OFF.
2. Disconnect the battery cable from the negative terminal.
3. Check the following terminals and connectors for damage, bend and loose connection (unit side and connector side).
 - BCM
 - Harness connector M84 (Models without around view monitor)
 - Harness connector B101 (Models without around view monitor)
 - Harness connector B124 (Models without around view monitor)
 - Harness connector B32 (Models without around view monitor)
 - Harness connector B69 (2WD models without automatic back door system)
 - Harness connector M40 (2WD models without automatic back door system)

Is the inspection result normal?

YES >> GO TO 2.

NO >> Repair the terminal and connector.

2. CHECK HARNESS FOR OPEN CIRCUIT

1. Disconnect the connector of BCM.
2. Check the resistance between the BCM harness connector terminals.

BCM harness connector			Resistance (Ω)
Connector No.	Terminal No.		
M19	60	59	Approx. 108 – 132

Is the measurement value within the specification?

YES >> GO TO 3.

NO >> Repair the BCM branch line.

3. CHECK POWER SUPPLY AND GROUND CIRCUIT

Check the power supply and the ground circuit of the BCM. Refer to [BCS-72, "Diagnosis Procedure"](#).

Is the inspection result normal?

YES (Present error)>>Replace the BCM. Refer to [BCS-78, "Removal and Installation"](#).

YES (Past error)>>Error was detected in the BCM branch line.

NO >> Repair the power supply and the ground circuit.

CAN COMMUNICATION CIRCUIT

< DTC/CIRCUIT DIAGNOSIS >

[CAN SYSTEM (TYPE 5)]

CAN COMMUNICATION CIRCUIT

Diagnosis Procedure

INFOID:000000008970591

1. CONNECTOR INSPECTION

1. Turn the ignition switch OFF.
2. Disconnect the battery cable from the negative terminal.
3. Disconnect all the unit connectors on CAN communication circuit.
4. Check terminals and connectors for damage, bend and loose connection.

Is the inspection result normal?

- YES >> GO TO 2.
NO >> Repair the terminal and connector.

2. CHECK HARNESS CONTINUITY (SHORT CIRCUIT)

Check the continuity between the data link connector terminals.

Data link connector		Continuity
Connector No.	Terminal No.	
M22	6 14	Not existed

Is the inspection result normal?

- YES >> GO TO 3.
NO >> Check the harness and repair the root cause.

3. CHECK HARNESS CONTINUITY (SHORT CIRCUIT)

Check the continuity between the data link connector and the ground.

Data link connector		Ground	Continuity
Connector No.	Terminal No.		
M22	6		Not existed
	14		Not existed

Is the inspection result normal?

- YES >> GO TO 4.
NO >> Check the harness and repair the root cause.

4. CHECK ECM AND BCM TERMINATION CIRCUIT

1. Remove the ECM and the BCM.
2. Check the resistance between the ECM terminals.

ECM		Resistance (Ω)
Terminal No.		
114	113	Approx. 108 – 132

3. Check the resistance between the BCM terminals.

BCM		Resistance (Ω)
Terminal No.		
60	59	Approx. 108 – 132

Is the measurement value within the specification?

- YES >> GO TO 5.
NO >> Replace the ECM and/or the BCM.

5. CHECK SYMPTOM

Connect all the connectors. Check if the symptoms described in the "Symptom (Results from interview with customer)" are reproduced.

A
B
C
D
E
F
G
H
I
J
K
L

LAN

N
O
P

CAN COMMUNICATION CIRCUIT

< DTC/CIRCUIT DIAGNOSIS >

[CAN SYSTEM (TYPE 5)]

Inspection result

Reproduced>>GO TO 6.

Non-reproduced>>Start the diagnosis again. Follow the trouble diagnosis procedure when past error is detected.

6.CHECK UNIT REPRODUCTION

Perform the reproduction test as per the following procedure for each unit.

1. Turn the ignition switch OFF.
2. Disconnect the battery cable from the negative terminal.
3. Disconnect one of the unit connectors of CAN communication circuit.

NOTE:

ECM and BCM have a termination circuit. Check other units first.

4. Connect the battery cable to the negative terminal. Check if the symptoms described in the “Symptom (Results from interview with customer)” are reproduced.

NOTE:

Although unit-related error symptoms occur, do not confuse them with other symptoms.

Inspection result

Reproduced>>Connect the connector. Check other units as per the above procedure.

Non-reproduced>>Replace the unit whose connector was disconnected.

MAIN LINE BETWEEN IPDM-E AND ABS CIRCUIT

< DTC/CIRCUIT DIAGNOSIS >

[CAN SYSTEM (TYPE 6)]

DTC/CIRCUIT DIAGNOSIS

MAIN LINE BETWEEN IPDM-E AND ABS CIRCUIT

Diagnosis Procedure

INFOID:000000008970595

1. CHECK HARNESS CONTINUITY (OPEN CIRCUIT)

1. Turn the ignition switch OFF.
2. Disconnect the battery cable from the negative terminal.
3. Disconnect the following harness connectors.
 - ECM
 - IPDM E/R
 - ABS actuator and electric unit (control unit)
4. Check the continuity between the IPDM E/R harness connector and the ABS actuator and electric unit (control unit) harness connector.

IPDM E/R harness connector		ABS actuator and electric unit (control unit) harness connector		Continuity
Connector No.	Terminal No.	Connector No.	Terminal No.	
E119	29	E125	25	Existed
	28		15	Existed

Is the inspection result normal?

YES (Present error)>>Check CAN system type decision again.

YES (Past error)>>Error was detected in the main line between the IPDM E/R and the ABS actuator and electric unit (control unit).

NO >> Repair the main line between the IPDM E/R and the ABS actuator and electric unit (control unit).

A
B
C
D
E
F
G
H
I
J
K
L
N
O
P

LAN

MAIN LINE BETWEEN ABS AND DLC CIRCUIT

< DTC/CIRCUIT DIAGNOSIS >

[CAN SYSTEM (TYPE 6)]

MAIN LINE BETWEEN ABS AND DLC CIRCUIT

Diagnosis Procedure

INFOID:000000008970596

1. CHECK CONNECTOR

1. Turn the ignition switch OFF.
2. Disconnect the battery cable from the negative terminal.
3. Check the following terminals and connectors for damage, bend and loose connection (connector side and harness side).
 - Harness connector E152
 - Harness connector M31

Is the inspection result normal?

YES >> GO TO 2.

NO >> Repair the terminal and connector.

2. CHECK HARNESS CONTINUITY (OPEN CIRCUIT)

1. Disconnect the following harness connectors.
 - ABS actuator and electric unit (control unit)
 - Harness connectors E152 and M31.
2. Check the continuity between the ABS actuator and electric unit (control unit) harness connector and the harness connector.

ABS actuator and electric unit (control unit) harness connector		Harness connector		Continuity
Connector No.	Terminal No.	Connector No.	Terminal No.	
E125	25	E152	36G	Existed
	15		35G	Existed

Is the inspection result normal?

YES >> GO TO 3.

NO >> Repair the main line between the ABS actuator and electric unit (control unit) and the harness connector E152.

3. CHECK HARNESS CONTINUITY (OPEN CIRCUIT)

Check the continuity between the harness connector and the data link connector.

Harness connector		Data link connector		Continuity
Connector No.	Terminal No.	Connector No.	Terminal No.	
M31	36G	M22	6	Existed
	35G		14	Existed

Is the inspection result normal?

YES (Present error)>>Check CAN system type decision again.

YES (Past error)>>Error was detected in the main line between the ABS actuator and electric unit (control unit) and the data link connector.

NO >> Repair the main line between the harness connector M31 and the data link connector.

MAIN LINE BETWEEN DLC AND 4WD CIRCUIT

< DTC/CIRCUIT DIAGNOSIS >

[CAN SYSTEM (TYPE 6)]

MAIN LINE BETWEEN DLC AND 4WD CIRCUIT

Diagnosis Procedure

INFOID:000000008970598

1. CHECK CONNECTOR

1. Turn the ignition switch OFF.
2. Disconnect the battery cable from the negative terminal.
3. Check the following terminals and connectors for damage, bend and loose connection (connector side and harness side).
 - Harness connector M40
 - Harness connector B69

Is the inspection result normal?

YES >> GO TO 2.

NO >> Repair the terminal and connector.

2. CHECK HARNESS CONTINUITY (OPEN CIRCUIT)

1. Disconnect the harness connectors M40 and B69.
2. Check the continuity between the data link connector and the harness connector.

Data link connector		Harness connector		Continuity
Connector No.	Terminal No.	Connector No.	Terminal No.	
M22	6	M40	89A	Existed
	14		90A	Existed

Is the inspection result normal?

YES >> GO TO 3.

NO >> Repair the main line between the data link connector and the harness connector M40.

3. CHECK HARNESS CONTINUITY (OPEN CIRCUIT)

1. Disconnect the connector of 4WD control unit.
2. Check the continuity between the harness connector and the 4WD control unit harness connector.

Harness connector		4WD control unit harness connector		Continuity
Connector No.	Terminal No.	Connector No.	Terminal No.	
B69	89A	B67	8	Existed
	90A		16	Existed

Is the inspection result normal?

YES (Present error)>>Check CAN system type decision again.

YES (Past error)>>Error was detected in the main line between the data link connector and the 4WD control unit.

NO >> Repair the main line between the harness connector B69 and the 4WD control unit.

A
B
C
D
E
F
G
H
I
J
K
L
N
O
P

LAN

ECM BRANCH LINE CIRCUIT

< DTC/CIRCUIT DIAGNOSIS >

[CAN SYSTEM (TYPE 6)]

ECM BRANCH LINE CIRCUIT

Diagnosis Procedure

INFOID:000000008970603

1. CHECK CONNECTOR

1. Turn the ignition switch OFF.
2. Disconnect the battery cable from the negative terminal.
3. Check the terminals and connectors of the ECM for damage, bend and loose connection (unit side and connector side).

Is the inspection result normal?

- YES >> GO TO 2.
NO >> Repair the terminal and connector.

2. CHECK HARNESS FOR OPEN CIRCUIT

1. Disconnect the connector of ECM.
2. Check the resistance between the ECM harness connector terminals.

ECM harness connector			Resistance (Ω)
Connector No.	Terminal No.		
E16	114	113	Approx. 108 – 132

Is the measurement value within the specification?

- YES >> GO TO 3.
NO >> Repair the ECM branch line.

3. CHECK POWER SUPPLY AND GROUND CIRCUIT

Check the power supply and the ground circuit of the ECM. Refer to [EC-170, "Diagnosis Procedure"](#).

Is the inspection result normal?

- YES (Present error)>>Replace the ECM. Refer to [EC-460, "Removal and Installation"](#).
YES (Past error)>>Error was detected in the ECM branch line.
NO >> Repair the power supply and the ground circuit.

IPDM-E BRANCH LINE CIRCUIT

< DTC/CIRCUIT DIAGNOSIS >

[CAN SYSTEM (TYPE 6)]

IPDM-E BRANCH LINE CIRCUIT

Diagnosis Procedure

INFOID:000000008970604

1. CHECK CONNECTOR

1. Turn the ignition switch OFF.
2. Disconnect the battery cable from the negative terminal.
3. Check the terminals and connectors of the IPDM E/R for damage, bend and loose connection (unit side and connector side).

Is the inspection result normal?

- YES >> GO TO 2.
NO >> Repair the terminal and connector.

2. CHECK HARNESS FOR OPEN CIRCUIT

1. Disconnect the connector of IPDM E/R.
2. Check the resistance between the IPDM E/R harness connector terminals.

IPDM E/R harness connector			Resistance (Ω)
Connector No.	Terminal No.		
E119	29	28	Approx. 54 – 66

Is the measurement value within the specification?

- YES >> GO TO 3.
NO >> Repair the IPDM E/R branch line.

3. CHECK POWER SUPPLY AND GROUND CIRCUIT

Check the power supply and the ground circuit of the IPDM E/R. Refer to [PCS-31, "Diagnosis Procedure"](#).

Is the inspection result normal?

- YES (Present error)>>Replace the IPDM E/R. Refer to [PCS-32, "Removal and Installation"](#).
YES (Past error)>>Error was detected in the IPDM E/R branch line.
NO >> Repair the power supply and the ground circuit.

A
B
C
D
E
F
G
H
I
J
K
L

LAN

TCM BRANCH LINE CIRCUIT

< DTC/CIRCUIT DIAGNOSIS >

[CAN SYSTEM (TYPE 6)]

TCM BRANCH LINE CIRCUIT

Diagnosis Procedure

INFOID:000000008970605

1. CHECK CONNECTOR

1. Turn the ignition switch OFF.
2. Disconnect the battery cable from the negative terminal.
3. Check the following terminals and connectors for damage, bend and loose connection (unit side and connector side).
 - TCM
 - Harness connector F32
 - Harness connector E2

Is the inspection result normal?

YES >> GO TO 2.

NO >> Repair the terminal and connector.

2. CHECK HARNESS FOR OPEN CIRCUIT

1. Disconnect the connector of TCM.
2. Check the resistance between the TCM harness connector terminals.

TCM harness connector		Resistance (Ω)
Connector No.	Terminal No.	
F15	33 23	Approx. 54 – 66

Is the measurement value within the specification?

YES >> GO TO 3.

NO >> Repair the TCM branch line.

3. CHECK POWER SUPPLY AND GROUND CIRCUIT

Check the power supply and the ground circuit of the TCM. Refer to [TM-165, "Diagnosis Procedure"](#).

Is the inspection result normal?

YES (Present error)>>Replace the TCM. Refer to [TM-197, "Removal and Installation"](#).

YES (Past error)>>Error was detected in the TCM branch line.

NO >> Repair the power supply and the ground circuit.

ABS BRANCH LINE CIRCUIT

< DTC/CIRCUIT DIAGNOSIS >

[CAN SYSTEM (TYPE 6)]

ABS BRANCH LINE CIRCUIT

Diagnosis Procedure

INFOID:000000008970606

1. CHECK CONNECTOR

1. Turn the ignition switch OFF.
2. Disconnect the battery cable from the negative terminal.
3. Check the terminals and connectors of the ABS actuator and electric unit (control unit) for damage, bend and loose connection (unit side and connector side).

Is the inspection result normal?

- YES >> GO TO 2.
NO >> Repair the terminal and connector.

2. CHECK HARNESS FOR OPEN CIRCUIT

1. Disconnect the connector of ABS actuator and electric unit (control unit).
2. Check the resistance between the ABS actuator and electric unit (control unit) harness connector terminals.

ABS actuator and electric unit (control unit) harness connector			Resistance (Ω)
Connector No.	Terminal No.		
E125	25	15	Approx. 54 – 66

Is the measurement value within the specification?

- YES >> GO TO 3.
NO >> Repair the ABS actuator and electric unit (control unit) branch line.

3. CHECK POWER SUPPLY AND GROUND CIRCUIT

Check the power supply and the ground circuit of the ABS actuator and electric unit (control unit). Refer to [BRC-63, "Diagnosis Procedure"](#).

Is the inspection result normal?

- YES (Present error)>>Replace the ABS actuator and electric unit (control unit). Refer to [BRC-121, "Removal and Installation"](#).
YES (Past error)>>Error was detected in the ABS actuator and electric unit (control unit) branch line.
NO >> Repair the power supply and the ground circuit.

A
B
C
D
E
F
G
H
I
J
K
L

LAN

EPS BRANCH LINE CIRCUIT

< DTC/CIRCUIT DIAGNOSIS >

[CAN SYSTEM (TYPE 6)]

EPS BRANCH LINE CIRCUIT

Diagnosis Procedure

INFOID:000000008970607

1. CHECK CONNECTOR

1. Turn the ignition switch OFF.
2. Disconnect the battery cable from the negative terminal.
3. Check the terminals and connectors of the power steering control module for damage, bend and loose connection (unit side and connector side).

Is the inspection result normal?

- YES >> GO TO 2.
NO >> Repair the terminal and connector.

2. CHECK HARNESS FOR OPEN CIRCUIT

1. Disconnect the connector of power steering control module.
2. Check the resistance between the power steering control module harness connector terminals.

Power steering control module harness connector			Resistance (Ω)
Connector No.	Terminal No.		
E62	8	7	Approx. 54 – 66

Is the measurement value within the specification?

- YES >> GO TO 3.
NO >> Repair the power steering control module branch line.

3. CHECK POWER SUPPLY AND GROUND CIRCUIT

Check the power supply and the ground circuit of the power steering control module. Refer to [STC-22, "Diagnosis Procedure"](#).

Is the inspection result normal?

- YES (Present error)>>Replace the power steering oil pump assembly. Refer to [ST-51, "Removal and Installation"](#).
YES (Past error)>>Error was detected in the power steering control module branch line.
NO >> Repair the power supply and the ground circuit.

A-BAG BRANCH LINE CIRCUIT

< DTC/CIRCUIT DIAGNOSIS >

[CAN SYSTEM (TYPE 6)]

A-BAG BRANCH LINE CIRCUIT

Diagnosis Procedure

INFOID:000000008970608

WARNING:

- Before servicing, turn ignition switch OFF, disconnect battery negative terminal, and wait 3 minutes or more. (To discharge backup capacitor.)
- Never use unspecified tester or other measuring device.

1.CHECK CONNECTOR

1. Turn the ignition switch OFF.
2. Disconnect the battery cable from the negative terminal.
3. Check the terminals and connectors of the air bag diagnosis sensor unit for damage, bend and loose connection (unit side and connector side).

Is the inspection result normal?

- YES >> GO TO 2.
NO >> Replace the main harness.

2.CHECK AIR BAG DIAGNOSIS SENSOR UNIT

Check the air bag diagnosis sensor unit. Refer to [SRC-40, "Work Flow"](#).

Is the inspection result normal?

- YES >> Replace the main harness.
NO >> Replace parts whose air bag system has a malfunction.

A
B
C
D
E
F
G
H
I
J
K
L
LAN
N
O
P

AV BRANCH LINE CIRCUIT

< DTC/CIRCUIT DIAGNOSIS >

[CAN SYSTEM (TYPE 6)]

AV BRANCH LINE CIRCUIT

Diagnosis Procedure

INFOID:000000008970609

1. CHECK CONNECTOR

1. Turn the ignition switch OFF.
2. Disconnect the battery cable from the negative terminal.
3. Check the terminals and connectors of the AV control unit for damage, bend and loose connection (unit side and connector side).

Is the inspection result normal?

- YES >> GO TO 2.
NO >> Repair the terminal and connector.

2. CHECK HARNESS FOR OPEN CIRCUIT

1. Disconnect the connector of AV control unit.
 2. Check the resistance between the AV control unit harness connector terminals.
- With BOSE audio without navigation

AV control unit harness connector			Resistance (Ω)
Connector No.	Terminal No.		
M42	11	12	Approx. 54 – 66

- Without BOSE audio with navigation

AV control unit harness connector			Resistance (Ω)
Connector No.	Terminal No.		
M124	11	12	Approx. 54 – 66

- With BOSE audio with navigation

AV control unit harness connector			Resistance (Ω)
Connector No.	Terminal No.		
M163	78	62	Approx. 54 – 66

Is the measurement value within the specification?

- YES >> GO TO 3.
NO >> Repair the AV control unit branch line.

3. CHECK POWER SUPPLY AND GROUND CIRCUIT

Check the power supply and the ground circuit of the AV control unit. Refer to the following.

- Mid audio without BOSE: [AV-143. "AV CONTROL UNIT : Diagnosis Procedure"](#)
- Mid audio with BOSE: [AV-303. "AV CONTROL UNIT : Diagnosis Procedure"](#)
- Premium audio with navigation: [AV-532. "AV CONTROL UNIT : Diagnosis Procedure"](#)

Is the inspection result normal?

- YES (Present error)>>Replace the AV control unit. Refer to the following.
- Mid audio without BOSE: [AV-186. "Removal and Installation"](#)
 - Mid audio with BOSE: [AV-357. "Removal and Installation"](#)
 - Premium audio with navigation: [AV-585. "Removal and Installation"](#)

YES (Past error)>>Error was detected in the AV control unit branch line.

NO >> Repair the power supply and the ground circuit.

DLC BRANCH LINE CIRCUIT

< DTC/CIRCUIT DIAGNOSIS >

[CAN SYSTEM (TYPE 6)]

DLC BRANCH LINE CIRCUIT

Diagnosis Procedure

INFOID:000000008970610

1. CHECK CONNECTOR

1. Turn the ignition switch OFF.
2. Disconnect the battery cable from the negative terminal.
3. Check the terminals and connectors of the data link connector for damage, bend and loose connection (connector side and harness side).

Is the inspection result normal?

- YES >> GO TO 2.
NO >> Repair the terminal and connector.

2. CHECK HARNESS FOR OPEN CIRCUIT

Check the resistance between the data link connector terminals.

Data link connector			Resistance (Ω)
Connector No.	Terminal No.		
M22	6	14	Approx. 54 – 66

Is the measurement value within the specification?

- YES (Present error)>>Check CAN system type decision again.
YES (Past error)>>Error was detected in the data link connector branch line circuit.
NO >> Repair the data link connector branch line.

A
B
C
D
E
F
G
H
I
J
K
L

LAN

N
O
P

HVAC BRANCH LINE CIRCUIT

< DTC/CIRCUIT DIAGNOSIS >

[CAN SYSTEM (TYPE 6)]

HVAC BRANCH LINE CIRCUIT

Diagnosis Procedure

INFOID:000000008970613

1. CHECK CONNECTOR

1. Turn the ignition switch OFF.
2. Disconnect the battery cable from the negative terminal.
3. Check the terminals and connectors of the A/C auto amp. for damage, bend and loose connection (unit side and connector side).

Is the inspection result normal?

- YES >> GO TO 2.
NO >> Repair the terminal and connector.

2. CHECK HARNESS FOR OPEN CIRCUIT

1. Disconnect the connector of A/C auto amp.
2. Check the resistance between the A/C auto amp. harness connector terminals.

A/C auto amp. harness connector			Resistance (Ω)
Connector No.	Terminal No.		
M50	1	21	Approx. 54 – 66

Is the measurement value within the specification?

- YES >> GO TO 3.
NO >> Repair the A/C auto amp. branch line.

3. CHECK POWER SUPPLY AND GROUND CIRCUIT

Check the power supply and the ground circuit of the A/C auto amp. Refer to [HAC-113, "A/C AUTO AMP. : Diagnosis Procedure"](#).

Is the inspection result normal?

- YES (Present error)>>Replace the A/C auto amp. Refer to [HAC-156, "Removal and Installation"](#).
YES (Past error)>>Error was detected in the A/C auto amp. branch line.
NO >> Repair the power supply and the ground circuit.

M&A BRANCH LINE CIRCUIT

< DTC/CIRCUIT DIAGNOSIS >

[CAN SYSTEM (TYPE 6)]

M&A BRANCH LINE CIRCUIT

Diagnosis Procedure

INFOID:000000008970614

1. CHECK CONNECTOR

1. Turn the ignition switch OFF.
2. Disconnect the battery cable from the negative terminal.
3. Check the terminals and connectors of the combination meter for damage, bend and loose connection (unit side and connector side).

Is the inspection result normal?

- YES >> GO TO 2.
NO >> Repair the terminal and connector.

2. CHECK HARNESS FOR OPEN CIRCUIT

1. Disconnect the connector of combination meter.
2. Check the resistance between the combination meter harness connector terminals.

Combination meter harness connector			Resistance (Ω)
Connector No.	Terminal No.		
M24	39	38	Approx. 54 – 66

Is the measurement value within the specification?

- YES >> GO TO 3.
NO >> Repair the combination meter branch line.

3. CHECK POWER SUPPLY AND GROUND CIRCUIT

Check the power supply and the ground circuit of the combination meter. Refer to [MWI-59, "COMBINATION METER : Diagnosis Procedure"](#).

Is the inspection result normal?

- YES (Present error)>>Replace the combination meter. Refer to [MWI-82, "Removal and Installation"](#).
YES (Past error)>>Error was detected in the combination meter branch line.
NO >> Repair the power supply and the ground circuit.

A
B
C
D
E
F
G
H
I
J
K
L
N
O
P

LAN

SONAR BRANCH LINE CIRCUIT

< DTC/CIRCUIT DIAGNOSIS >

[CAN SYSTEM (TYPE 6)]

SONAR BRANCH LINE CIRCUIT

Diagnosis Procedure

INFOID:000000008970615

1. CHECK CONNECTOR

1. Turn the ignition switch OFF.
2. Disconnect the battery cable from the negative terminal.
3. Check the terminals and connectors of sonar control unit for damage, bend and loose connection (unit side and connector side).

Is the inspection result normal?

- YES >> GO TO 2.
NO >> Repair the terminal and connector.

2. CHECK HARNESS FOR OPEN CIRCUIT

1. Disconnect the connector of sonar control unit.
2. Check the resistance between the sonar control unit harness connector terminals.

Sonar control unit harness connector			Resistance (Ω)
Connector No.	Terminal No.		
M70	5	6	Approx. 54 – 66

Is the measurement value within the specification?

- YES >> GO TO 3.
NO >> Replace the main harness.

3. CHECK POWER SUPPLY AND GROUND CIRCUIT

Check the power supply and the ground circuit of the sonar control unit. Refer to [SN-32, "Diagnosis Procedure"](#).

Is the inspection result normal?

- YES (Present error)>>Replace the sonar control unit. Refer to [SN-34, "Removal and Installation"](#).
YES (Past error)>>Error was detected in the sonar control unit branch line.
NO >> Repair the power supply and the ground circuit.

STRG BRANCH LINE CIRCUIT

< DTC/CIRCUIT DIAGNOSIS >

[CAN SYSTEM (TYPE 6)]

STRG BRANCH LINE CIRCUIT

Diagnosis Procedure

INFOID:000000008970616

1. CHECK CONNECTOR

1. Turn the ignition switch OFF.
2. Disconnect the battery cable from the negative terminal.
3. Check the terminals and connectors of the steering angle sensor for damage, bend and loose connection (unit side and connector side).

Is the inspection result normal?

- YES >> GO TO 2.
NO >> Repair the terminal and connector.

2. CHECK HARNESS FOR OPEN CIRCUIT

1. Disconnect the connector of steering angle sensor.
2. Check the resistance between the steering angle sensor harness connector terminals.

Steering angle sensor harness connector			Resistance (Ω)
Connector No.	Terminal No.		
M54	5	2	Approx. 54 – 66

Is the measurement value within the specification?

- YES >> GO TO 3.
NO >> Repair the steering angle sensor branch line.

3. CHECK POWER SUPPLY AND GROUND CIRCUIT

Check the power supply and the ground circuit of the steering angle sensor. Refer to [BRC-44, "Wiring Diagram"](#).

Is the inspection result normal?

- YES (Present error)>>Replace the steering angle sensor. Refer to [BRC-124, "Removal and Installation"](#).
YES (Past error)>>Error was detected in the steering angle sensor branch line.
NO >> Repair the power supply and the ground circuit.

A
B
C
D
E
F
G
H
I
J
K
L

LAN

N
O
P

4WD BRANCH LINE CIRCUIT

< DTC/CIRCUIT DIAGNOSIS >

[CAN SYSTEM (TYPE 6)]

4WD BRANCH LINE CIRCUIT

Diagnosis Procedure

INFOID:000000008970618

1. CHECK CONNECTOR

1. Turn the ignition switch OFF.
2. Disconnect the battery cable from the negative terminal.
3. Check the following terminals and connectors for damage, bend and loose connection (unit side and connector side).
 - 4WD control unit
 - CAN gateway (Models with around view monitor)

Is the inspection result normal?

- YES-1 >> Models with around view monitor: GO TO 2.
YES-2 >> Models without around view monitor: GO TO 3.
NO >> Repair the terminal and connector.

2. CHECK HARNESS CONTINUITY (OPEN CIRCUIT)

1. Disconnect the connector of CAN gateway.
2. Check the continuity between the CAN gateway harness connector terminals.

CAN gateway harness connector		Continuity	
Connector No.	Terminal No.		
M5	4	6	Existed
	10	12	Existed

Is the inspection result normal?

- YES >> GO TO 3.
NO >> Check the harness and repair the root cause (CAN communication circuit 2 side).

3. CHECK HARNESS FOR OPEN CIRCUIT

1. Connect the connector of CAN gateway. (Models with around view monitor)
2. Disconnect the connector of 4WD control unit.
3. Check the resistance between the 4WD control unit harness connector terminals.

4WD control unit harness connector		Resistance (Ω)	
Connector No.	Terminal No.		
B67	8	16	Approx. 54 – 66

Is the measurement value within the specification?

- YES >> GO TO 4.
NO >> Repair the 4WD control unit branch line.

4. CHECK POWER SUPPLY AND GROUND CIRCUIT

Check the power supply and the ground circuit of the 4WD control unit. Refer to [DLN-59, "Diagnosis Procedure"](#).

Is the inspection result normal?

- YES (Present error)>>Replace the 4WD control unit. Refer to [DLN-71, "Removal and Installation"](#).
YES (Past error)>>Error was detected in the 4WD control unit branch line.
NO >> Repair the power supply and the ground circuit.

BCM BRANCH LINE CIRCUIT

< DTC/CIRCUIT DIAGNOSIS >

[CAN SYSTEM (TYPE 6)]

BCM BRANCH LINE CIRCUIT

Diagnosis Procedure

INFOID:000000008970620

1. CHECK CONNECTOR

1. Turn the ignition switch OFF.
2. Disconnect the battery cable from the negative terminal.
3. Check the following terminals and connectors for damage, bend and loose connection (unit side and connector side).
 - BCM
 - Harness connector M84 (Models without around view monitor)
 - Harness connector B101 (Models without around view monitor)
 - Harness connector B124 (Models without around view monitor)
 - Harness connector B32 (Models without around view monitor)
 - Harness connector B69 (2WD models without automatic back door system)
 - Harness connector M40 (2WD models without automatic back door system)

Is the inspection result normal?

YES >> GO TO 2.

NO >> Repair the terminal and connector.

2. CHECK HARNESS FOR OPEN CIRCUIT

1. Disconnect the connector of BCM.
2. Check the resistance between the BCM harness connector terminals.

BCM harness connector			Resistance (Ω)
Connector No.	Terminal No.		
M19	60	59	Approx. 108 – 132

Is the measurement value within the specification?

YES >> GO TO 3.

NO >> Repair the BCM branch line.

3. CHECK POWER SUPPLY AND GROUND CIRCUIT

Check the power supply and the ground circuit of the BCM. Refer to [BCS-72, "Diagnosis Procedure"](#).

Is the inspection result normal?

YES (Present error)>>Replace the BCM. Refer to [BCS-78, "Removal and Installation"](#).

YES (Past error)>>Error was detected in the BCM branch line.

NO >> Repair the power supply and the ground circuit.

A
B
C
D
E
F
G
H
I
J
K
L

LAN

CAN COMMUNICATION CIRCUIT

< DTC/CIRCUIT DIAGNOSIS >

[CAN SYSTEM (TYPE 6)]

CAN COMMUNICATION CIRCUIT

Diagnosis Procedure

INFOID:000000008970624

1.CONNECTOR INSPECTION

1. Turn the ignition switch OFF.
2. Disconnect the battery cable from the negative terminal.
3. Disconnect all the unit connectors on CAN communication circuit.
4. Check terminals and connectors for damage, bend and loose connection.

Is the inspection result normal?

- YES >> GO TO 2.
NO >> Repair the terminal and connector.

2.CHECK HARNESS CONTINUITY (SHORT CIRCUIT)

Check the continuity between the data link connector terminals.

Data link connector			Continuity
Connector No.	Terminal No.		
M22	6	14	Not existed

Is the inspection result normal?

- YES >> GO TO 3.
NO >> Check the harness and repair the root cause.

3.CHECK HARNESS CONTINUITY (SHORT CIRCUIT)

Check the continuity between the data link connector and the ground.

Data link connector		Ground	Continuity
Connector No.	Terminal No.		
M22	6		Not existed
	14		Not existed

Is the inspection result normal?

- YES >> GO TO 4.
NO >> Check the harness and repair the root cause.

4.CHECK ECM AND BCM TERMINATION CIRCUIT

1. Remove the ECM and the BCM.
2. Check the resistance between the ECM terminals.

ECM		Resistance (Ω)
Terminal No.		
114	113	Approx. 108 – 132

3. Check the resistance between the BCM terminals.

BCM		Resistance (Ω)
Terminal No.		
60	59	Approx. 108 – 132

Is the measurement value within the specification?

- YES >> GO TO 5.
NO >> Replace the ECM and/or the BCM.

5.CHECK SYMPTOM

Connect all the connectors. Check if the symptoms described in the “Symptom (Results from interview with customer)” are reproduced.

CAN COMMUNICATION CIRCUIT

< DTC/CIRCUIT DIAGNOSIS >

[CAN SYSTEM (TYPE 6)]

Inspection result

Reproduced>>GO TO 6.

Non-reproduced>>Start the diagnosis again. Follow the trouble diagnosis procedure when past error is detected.

6.CHECK UNIT REPRODUCTION

Perform the reproduction test as per the following procedure for each unit.

1. Turn the ignition switch OFF.
2. Disconnect the battery cable from the negative terminal.
3. Disconnect one of the unit connectors of CAN communication circuit.

NOTE:

ECM and BCM have a termination circuit. Check other units first.

4. Connect the battery cable to the negative terminal. Check if the symptoms described in the “Symptom (Results from interview with customer)” are reproduced.

NOTE:

Although unit-related error symptoms occur, do not confuse them with other symptoms.

Inspection result

Reproduced>>Connect the connector. Check other units as per the above procedure.

Non-reproduced>>Replace the unit whose connector was disconnected.

A
B
C
D
E
F
G
H
I
J
K
L
N
O
P

LAN

MAIN LINE BETWEEN IPDM-E AND ABS CIRCUIT

< DTC/CIRCUIT DIAGNOSIS >

[CAN SYSTEM (TYPE 7)]

DTC/CIRCUIT DIAGNOSIS

MAIN LINE BETWEEN IPDM-E AND ABS CIRCUIT

Diagnosis Procedure

INFOID:000000008970627

1. CHECK HARNESS CONTINUITY (OPEN CIRCUIT)

1. Turn the ignition switch OFF.
2. Disconnect the battery cable from the negative terminal.
3. Disconnect the following harness connectors.
 - ECM
 - IPDM E/R
 - ABS actuator and electric unit (control unit)
4. Check the continuity between the IPDM E/R harness connector and the ABS actuator and electric unit (control unit) harness connector.

IPDM E/R harness connector		ABS actuator and electric unit (control unit) harness connector		Continuity
Connector No.	Terminal No.	Connector No.	Terminal No.	
E119	29	E125	25	Existed
	28		15	Existed

Is the inspection result normal?

YES (Present error)>>Check CAN system type decision again.

YES (Past error)>>Error was detected in the main line between the IPDM E/R and the ABS actuator and electric unit (control unit).

NO >> Repair the main line between the IPDM E/R and the ABS actuator and electric unit (control unit).

MAIN LINE BETWEEN ABS AND DLC CIRCUIT

< DTC/CIRCUIT DIAGNOSIS >

[CAN SYSTEM (TYPE 7)]

MAIN LINE BETWEEN ABS AND DLC CIRCUIT

Diagnosis Procedure

INFOID:000000008970628

1.CHECK CONNECTOR

1. Turn the ignition switch OFF.
2. Disconnect the battery cable from the negative terminal.
3. Check the following terminals and connectors for damage, bend and loose connection (connector side and harness side).
 - Harness connector E152
 - Harness connector M31

Is the inspection result normal?

YES >> GO TO 2.

NO >> Repair the terminal and connector.

2.CHECK HARNESS CONTINUITY (OPEN CIRCUIT)

1. Disconnect the following harness connectors.
 - ABS actuator and electric unit (control unit)
 - Harness connectors E152 and M31.
2. Check the continuity between the ABS actuator and electric unit (control unit) harness connector and the harness connector.

ABS actuator and electric unit (control unit) harness connector		Harness connector		Continuity
Connector No.	Terminal No.	Connector No.	Terminal No.	
E125	25	E152	36G	Existed
	15		35G	Existed

Is the inspection result normal?

YES >> GO TO 3.

NO >> Repair the main line between the ABS actuator and electric unit (control unit) and the harness connector E152.

3.CHECK HARNESS CONTINUITY (OPEN CIRCUIT)

Check the continuity between the harness connector and the data link connector.

Harness connector		Data link connector		Continuity
Connector No.	Terminal No.	Connector No.	Terminal No.	
M31	36G	M22	6	Existed
	35G		14	Existed

Is the inspection result normal?

YES (Present error)>>Check CAN system type decision again.

YES (Past error)>>Error was detected in the main line between the ABS actuator and electric unit (control unit) and the data link connector.

NO >> Repair the main line between the harness connector M31 and the data link connector.

A
B
C
D
E
F
G
H
I
J
K
L
LAN
N
O
P

MAIN LINE BETWEEN DLC AND 4WD CIRCUIT

< DTC/CIRCUIT DIAGNOSIS >

[CAN SYSTEM (TYPE 7)]

MAIN LINE BETWEEN DLC AND 4WD CIRCUIT

Diagnosis Procedure

INFOID:000000008970630

1. CHECK CONNECTOR

1. Turn the ignition switch OFF.
2. Disconnect the battery cable from the negative terminal.
3. Check the following terminals and connectors for damage, bend and loose connection (connector side and harness side).
 - Harness connector M40
 - Harness connector B69

Is the inspection result normal?

YES >> GO TO 2.

NO >> Repair the terminal and connector.

2. CHECK HARNESS CONTINUITY (OPEN CIRCUIT)

1. Disconnect the harness connectors M40 and B69.
2. Check the continuity between the data link connector and the harness connector.

Data link connector		Harness connector		Continuity
Connector No.	Terminal No.	Connector No.	Terminal No.	
M22	6	M40	89A	Existed
	14		90A	Existed

Is the inspection result normal?

YES >> GO TO 3.

NO >> Repair the main line between the data link connector and the harness connector M40.

3. CHECK HARNESS CONTINUITY (OPEN CIRCUIT)

1. Disconnect the connector of 4WD control unit.
2. Check the continuity between the harness connector and the 4WD control unit harness connector.

Harness connector		4WD control unit harness connector		Continuity
Connector No.	Terminal No.	Connector No.	Terminal No.	
B69	89A	B67	8	Existed
	90A		16	Existed

Is the inspection result normal?

YES (Present error)>>Check CAN system type decision again.

YES (Past error)>>Error was detected in the main line between the data link connector and the 4WD control unit.

NO >> Repair the main line between the harness connector B69 and the 4WD control unit.

ECM BRANCH LINE CIRCUIT

< DTC/CIRCUIT DIAGNOSIS >

[CAN SYSTEM (TYPE 7)]

ECM BRANCH LINE CIRCUIT

Diagnosis Procedure

INFOID:000000008970635

1. CHECK CONNECTOR

1. Turn the ignition switch OFF.
2. Disconnect the battery cable from the negative terminal.
3. Check the terminals and connectors of the ECM for damage, bend and loose connection (unit side and connector side).

Is the inspection result normal?

- YES >> GO TO 2.
NO >> Repair the terminal and connector.

2. CHECK HARNESS FOR OPEN CIRCUIT

1. Disconnect the connector of ECM.
2. Check the resistance between the ECM harness connector terminals.

ECM harness connector			Resistance (Ω)
Connector No.	Terminal No.		
E16	114	113	Approx. 108 – 132

Is the measurement value within the specification?

- YES >> GO TO 3.
NO >> Repair the ECM branch line.

3. CHECK POWER SUPPLY AND GROUND CIRCUIT

Check the power supply and the ground circuit of the ECM. Refer to [EC-170. "Diagnosis Procedure"](#).

Is the inspection result normal?

- YES (Present error)>>Replace the ECM. Refer to [EC-460. "Removal and Installation"](#).
YES (Past error)>>Error was detected in the ECM branch line.
NO >> Repair the power supply and the ground circuit.

A
B
C
D
E
F
G
H
I
J
K
L

LAN

N
O
P

IPDM-E BRANCH LINE CIRCUIT

< DTC/CIRCUIT DIAGNOSIS >

[CAN SYSTEM (TYPE 7)]

IPDM-E BRANCH LINE CIRCUIT

Diagnosis Procedure

INFOID:000000008970636

1. CHECK CONNECTOR

1. Turn the ignition switch OFF.
2. Disconnect the battery cable from the negative terminal.
3. Check the terminals and connectors of the IPDM E/R for damage, bend and loose connection (unit side and connector side).

Is the inspection result normal?

- YES >> GO TO 2.
NO >> Repair the terminal and connector.

2. CHECK HARNESS FOR OPEN CIRCUIT

1. Disconnect the connector of IPDM E/R.
2. Check the resistance between the IPDM E/R harness connector terminals.

IPDM E/R harness connector			Resistance (Ω)
Connector No.	Terminal No.		
E119	29	28	Approx. 54 – 66

Is the measurement value within the specification?

- YES >> GO TO 3.
NO >> Repair the IPDM E/R branch line.

3. CHECK POWER SUPPLY AND GROUND CIRCUIT

Check the power supply and the ground circuit of the IPDM E/R. Refer to [PCS-31, "Diagnosis Procedure"](#).

Is the inspection result normal?

- YES (Present error)>>Replace the IPDM E/R. Refer to [PCS-32, "Removal and Installation"](#).
YES (Past error)>>Error was detected in the IPDM E/R branch line.
NO >> Repair the power supply and the ground circuit.

TCM BRANCH LINE CIRCUIT

< DTC/CIRCUIT DIAGNOSIS >

[CAN SYSTEM (TYPE 7)]

TCM BRANCH LINE CIRCUIT

Diagnosis Procedure

INFOID:000000008970637

1. CHECK CONNECTOR

1. Turn the ignition switch OFF.
2. Disconnect the battery cable from the negative terminal.
3. Check the following terminals and connectors for damage, bend and loose connection (unit side and connector side).
 - TCM
 - Harness connector F32
 - Harness connector E2

Is the inspection result normal?

- YES >> GO TO 2.
NO >> Repair the terminal and connector.

2. CHECK HARNESS FOR OPEN CIRCUIT

1. Disconnect the connector of TCM.
2. Check the resistance between the TCM harness connector terminals.

TCM harness connector		Resistance (Ω)
Connector No.	Terminal No.	
F15	33 23	Approx. 54 – 66

Is the measurement value within the specification?

- YES >> GO TO 3.
NO >> Repair the TCM branch line.

3. CHECK POWER SUPPLY AND GROUND CIRCUIT

Check the power supply and the ground circuit of the TCM. Refer to [TM-165, "Diagnosis Procedure"](#).

Is the inspection result normal?

- YES (Present error)>>Replace the TCM. Refer to [TM-197, "Removal and Installation"](#).
YES (Past error)>>Error was detected in the TCM branch line.
NO >> Repair the power supply and the ground circuit.

A
B
C
D
E
F
G
H
I
J
K
L

LAN

ABS BRANCH LINE CIRCUIT

< DTC/CIRCUIT DIAGNOSIS >

[CAN SYSTEM (TYPE 7)]

ABS BRANCH LINE CIRCUIT

Diagnosis Procedure

INFOID:000000008970638

1. CHECK CONNECTOR

1. Turn the ignition switch OFF.
2. Disconnect the battery cable from the negative terminal.
3. Check the terminals and connectors of the ABS actuator and electric unit (control unit) for damage, bend and loose connection (unit side and connector side).

Is the inspection result normal?

- YES >> GO TO 2.
NO >> Repair the terminal and connector.

2. CHECK HARNESS FOR OPEN CIRCUIT

1. Disconnect the connector of ABS actuator and electric unit (control unit).
2. Check the resistance between the ABS actuator and electric unit (control unit) harness connector terminals.

ABS actuator and electric unit (control unit) harness connector			Resistance (Ω)
Connector No.	Terminal No.		
E125	25	15	Approx. 54 – 66

Is the measurement value within the specification?

- YES >> GO TO 3.
NO >> Repair the ABS actuator and electric unit (control unit) branch line.

3. CHECK POWER SUPPLY AND GROUND CIRCUIT

Check the power supply and the ground circuit of the ABS actuator and electric unit (control unit). Refer to [BRC-63, "Diagnosis Procedure"](#).

Is the inspection result normal?

- YES (Present error)>>Replace the ABS actuator and electric unit (control unit). Refer to [BRC-121, "Removal and Installation"](#).
YES (Past error)>>Error was detected in the ABS actuator and electric unit (control unit) branch line.
NO >> Repair the power supply and the ground circuit.

EPS BRANCH LINE CIRCUIT

< DTC/CIRCUIT DIAGNOSIS >

[CAN SYSTEM (TYPE 7)]

EPS BRANCH LINE CIRCUIT

Diagnosis Procedure

INFOID:000000008970639

1. CHECK CONNECTOR

1. Turn the ignition switch OFF.
2. Disconnect the battery cable from the negative terminal.
3. Check the terminals and connectors of the power steering control module for damage, bend and loose connection (unit side and connector side).

Is the inspection result normal?

- YES >> GO TO 2.
NO >> Repair the terminal and connector.

2. CHECK HARNESS FOR OPEN CIRCUIT

1. Disconnect the connector of power steering control module.
2. Check the resistance between the power steering control module harness connector terminals.

Power steering control module harness connector			Resistance (Ω)
Connector No.	Terminal No.		
E62	8	7	Approx. 54 – 66

Is the measurement value within the specification?

- YES >> GO TO 3.
NO >> Repair the power steering control module branch line.

3. CHECK POWER SUPPLY AND GROUND CIRCUIT

Check the power supply and the ground circuit of the power steering control module. Refer to [STC-22, "Diagnosis Procedure"](#).

Is the inspection result normal?

- YES (Present error)>>Replace the power steering oil pump assembly. Refer to [ST-51, "Removal and Installation"](#).
YES (Past error)>>Error was detected in the power steering control module branch line.
NO >> Repair the power supply and the ground circuit.

A
B
C
D
E
F
G
H
I
J
K
L

LAN

A-BAG BRANCH LINE CIRCUIT

< DTC/CIRCUIT DIAGNOSIS >

[CAN SYSTEM (TYPE 7)]

A-BAG BRANCH LINE CIRCUIT

Diagnosis Procedure

INFOID:000000008970640

WARNING:

- Before servicing, turn ignition switch OFF, disconnect battery negative terminal, and wait 3 minutes or more. (To discharge backup capacitor.)
- Never use unspecified tester or other measuring device.

1. CHECK CONNECTOR

1. Turn the ignition switch OFF.
2. Disconnect the battery cable from the negative terminal.
3. Check the terminals and connectors of the air bag diagnosis sensor unit for damage, bend and loose connection (unit side and connector side).

Is the inspection result normal?

YES >> GO TO 2.

NO >> Replace the main harness.

2. CHECK AIR BAG DIAGNOSIS SENSOR UNIT

Check the air bag diagnosis sensor unit. Refer to [SRC-40, "Work Flow"](#).

Is the inspection result normal?

YES >> Replace the main harness.

NO >> Replace parts whose air bag system has a malfunction.

AV BRANCH LINE CIRCUIT

< DTC/CIRCUIT DIAGNOSIS >

[CAN SYSTEM (TYPE 7)]

AV BRANCH LINE CIRCUIT

Diagnosis Procedure

INFOID:000000008970641

1. CHECK CONNECTOR

1. Turn the ignition switch OFF.
2. Disconnect the battery cable from the negative terminal.
3. Check the terminals and connectors of the AV control unit for damage, bend and loose connection (unit side and connector side).

Is the inspection result normal?

- YES >> GO TO 2.
NO >> Repair the terminal and connector.

2. CHECK HARNESS FOR OPEN CIRCUIT

1. Disconnect the connector of AV control unit.
 2. Check the resistance between the AV control unit harness connector terminals.
- With BOSE audio without navigation

AV control unit harness connector			Resistance (Ω)
Connector No.	Terminal No.		
M42	11	12	Approx. 54 – 66

- Without BOSE audio with navigation

AV control unit harness connector			Resistance (Ω)
Connector No.	Terminal No.		
M124	11	12	Approx. 54 – 66

- With BOSE audio with navigation

AV control unit harness connector			Resistance (Ω)
Connector No.	Terminal No.		
M163	78	62	Approx. 54 – 66

Is the measurement value within the specification?

- YES >> GO TO 3.
NO >> Repair the AV control unit branch line.

3. CHECK POWER SUPPLY AND GROUND CIRCUIT

Check the power supply and the ground circuit of the AV control unit. Refer to the following.

- Mid audio without BOSE: [AV-143, "AV CONTROL UNIT : Diagnosis Procedure"](#)
- Mid audio with BOSE: [AV-303, "AV CONTROL UNIT : Diagnosis Procedure"](#)
- Premium audio with navigation: [AV-532, "AV CONTROL UNIT : Diagnosis Procedure"](#)

Is the inspection result normal?

- YES (Present error)>>Replace the AV control unit. Refer to the following.
- Mid audio without BOSE: [AV-186, "Removal and Installation"](#)
 - Mid audio with BOSE: [AV-357, "Removal and Installation"](#)
 - Premium audio with navigation: [AV-585, "Removal and Installation"](#)

YES (Past error)>>Error was detected in the AV control unit branch line.

- NO >> Repair the power supply and the ground circuit.

A
B
C
D
E
F
G
H
I
J
K
L
N
O
P

LAN

DLC BRANCH LINE CIRCUIT

< DTC/CIRCUIT DIAGNOSIS >

[CAN SYSTEM (TYPE 7)]

DLC BRANCH LINE CIRCUIT

Diagnosis Procedure

INFOID:000000008970642

1. CHECK CONNECTOR

1. Turn the ignition switch OFF.
2. Disconnect the battery cable from the negative terminal.
3. Check the terminals and connectors of the data link connector for damage, bend and loose connection (connector side and harness side).

Is the inspection result normal?

- YES >> GO TO 2.
NO >> Repair the terminal and connector.

2. CHECK HARNESS FOR OPEN CIRCUIT

Check the resistance between the data link connector terminals.

Data link connector			Resistance (Ω)
Connector No.	Terminal No.		
M22	6	14	Approx. 54 – 66

Is the measurement value within the specification?

- YES (Present error)>>Check CAN system type decision again.
YES (Past error)>>Error was detected in the data link connector branch line circuit.
NO >> Repair the data link connector branch line.

HVAC BRANCH LINE CIRCUIT

< DTC/CIRCUIT DIAGNOSIS >

[CAN SYSTEM (TYPE 7)]

HVAC BRANCH LINE CIRCUIT

Diagnosis Procedure

INFOID:000000008970645

1. CHECK CONNECTOR

1. Turn the ignition switch OFF.
2. Disconnect the battery cable from the negative terminal.
3. Check the terminals and connectors of the A/C auto amp. for damage, bend and loose connection (unit side and connector side).

Is the inspection result normal?

- YES >> GO TO 2.
NO >> Repair the terminal and connector.

2. CHECK HARNESS FOR OPEN CIRCUIT

1. Disconnect the connector of A/C auto amp.
2. Check the resistance between the A/C auto amp. harness connector terminals.

A/C auto amp. harness connector			Resistance (Ω)
Connector No.	Terminal No.		
M50	1	21	Approx. 54 – 66

Is the measurement value within the specification?

- YES >> GO TO 3.
NO >> Repair the A/C auto amp. branch line.

3. CHECK POWER SUPPLY AND GROUND CIRCUIT

Check the power supply and the ground circuit of the A/C auto amp. Refer to [HAC-113, "A/C AUTO AMP. : Diagnosis Procedure"](#).

Is the inspection result normal?

- YES (Present error)>>Replace the A/C auto amp. Refer to [HAC-156, "Removal and Installation"](#).
YES (Past error)>>Error was detected in the A/C auto amp. branch line.
NO >> Repair the power supply and the ground circuit.

A
B
C
D
E
F
G
H
I
J
K
L

LAN

N
O
P

M&A BRANCH LINE CIRCUIT

Diagnosis Procedure

INFOID:000000008970646

1.CHECK CONNECTOR

1. Turn the ignition switch OFF.
2. Disconnect the battery cable from the negative terminal.
3. Check the terminals and connectors of the combination meter for damage, bend and loose connection (unit side and connector side).

Is the inspection result normal?

- YES >> GO TO 2.
 NO >> Repair the terminal and connector.

2.CHECK HARNESS FOR OPEN CIRCUIT

1. Disconnect the connector of combination meter.
2. Check the resistance between the combination meter harness connector terminals.

Combination meter harness connector			Resistance (Ω)
Connector No.	Terminal No.		
M24	39	38	Approx. 54 – 66

Is the measurement value within the specification?

- YES >> GO TO 3.
 NO >> Repair the combination meter branch line.

3.CHECK POWER SUPPLY AND GROUND CIRCUIT

Check the power supply and the ground circuit of the combination meter. Refer to [MWI-59, "COMBINATION METER : Diagnosis Procedure"](#).

Is the inspection result normal?

- YES (Present error)>>Replace the combination meter. Refer to [MWI-82, "Removal and Installation"](#).
 YES (Past error)>>Error was detected in the combination meter branch line.
 NO >> Repair the power supply and the ground circuit.

SONAR BRANCH LINE CIRCUIT

< DTC/CIRCUIT DIAGNOSIS >

[CAN SYSTEM (TYPE 7)]

SONAR BRANCH LINE CIRCUIT

Diagnosis Procedure

INFOID:000000008970647

1. CHECK CONNECTOR

1. Turn the ignition switch OFF.
2. Disconnect the battery cable from the negative terminal.
3. Check the terminals and connectors of sonar control unit for damage, bend and loose connection (unit side and connector side).

Is the inspection result normal?

- YES >> GO TO 2.
NO >> Repair the terminal and connector.

2. CHECK HARNESS FOR OPEN CIRCUIT

1. Disconnect the connector of sonar control unit.
2. Check the resistance between the sonar control unit harness connector terminals.

Sonar control unit harness connector			Resistance (Ω)
Connector No.	Terminal No.		
M70	5	6	Approx. 54 – 66

Is the measurement value within the specification?

- YES >> GO TO 3.
NO >> Replace the main harness.

3. CHECK POWER SUPPLY AND GROUND CIRCUIT

Check the power supply and the ground circuit of the sonar control unit. Refer to [SN-32, "Diagnosis Procedure"](#).

Is the inspection result normal?

- YES (Present error)>>Replace the sonar control unit. Refer to [SN-34, "Removal and Installation"](#).
YES (Past error)>>Error was detected in the sonar control unit branch line.
NO >> Repair the power supply and the ground circuit.

A
B
C
D
E
F
G
H
I
J
K
L

LAN

STRG BRANCH LINE CIRCUIT

< DTC/CIRCUIT DIAGNOSIS >

[CAN SYSTEM (TYPE 7)]

STRG BRANCH LINE CIRCUIT

Diagnosis Procedure

INFOID:000000008970648

1. CHECK CONNECTOR

1. Turn the ignition switch OFF.
2. Disconnect the battery cable from the negative terminal.
3. Check the terminals and connectors of the steering angle sensor for damage, bend and loose connection (unit side and connector side).

Is the inspection result normal?

- YES >> GO TO 2.
NO >> Repair the terminal and connector.

2. CHECK HARNESS FOR OPEN CIRCUIT

1. Disconnect the connector of steering angle sensor.
2. Check the resistance between the steering angle sensor harness connector terminals.

Steering angle sensor harness connector			Resistance (Ω)
Connector No.	Terminal No.		
M54	5	2	Approx. 54 – 66

Is the measurement value within the specification?

- YES >> GO TO 3.
NO >> Repair the steering angle sensor branch line.

3. CHECK POWER SUPPLY AND GROUND CIRCUIT

Check the power supply and the ground circuit of the steering angle sensor. Refer to [BRC-44, "Wiring Diagram"](#).

Is the inspection result normal?

- YES (Present error)>>Replace the steering angle sensor. Refer to [BRC-124, "Removal and Installation"](#).
YES (Past error)>>Error was detected in the steering angle sensor branch line.
NO >> Repair the power supply and the ground circuit.

4WD BRANCH LINE CIRCUIT

< DTC/CIRCUIT DIAGNOSIS >

[CAN SYSTEM (TYPE 7)]

4WD BRANCH LINE CIRCUIT

Diagnosis Procedure

INFOID:000000008970650

1. CHECK CONNECTOR

1. Turn the ignition switch OFF.
2. Disconnect the battery cable from the negative terminal.
3. Check the following terminals and connectors for damage, bend and loose connection (unit side and connector side).
 - 4WD control unit
 - CAN gateway (Models with around view monitor)

Is the inspection result normal?

- YES-1 >> Models with around view monitor: GO TO 2.
YES-2 >> Models without around view monitor: GO TO 3.
NO >> Repair the terminal and connector.

2. CHECK HARNESS CONTINUITY (OPEN CIRCUIT)

1. Disconnect the connector of CAN gateway.
2. Check the continuity between the CAN gateway harness connector terminals.

CAN gateway harness connector		Continuity	
Connector No.	Terminal No.		
M5	4	6	Existed
	10	12	Existed

Is the inspection result normal?

- YES >> GO TO 3.
NO >> Check the harness and repair the root cause (CAN communication circuit 2 side).

3. CHECK HARNESS FOR OPEN CIRCUIT

1. Connect the connector of CAN gateway. (Models with around view monitor)
2. Disconnect the connector of 4WD control unit.
3. Check the resistance between the 4WD control unit harness connector terminals.

4WD control unit harness connector		Resistance (Ω)	
Connector No.	Terminal No.		
B67	8	16	Approx. 54 – 66

Is the measurement value within the specification?

- YES >> GO TO 4.
NO >> Repair the 4WD control unit branch line.

4. CHECK POWER SUPPLY AND GROUND CIRCUIT

Check the power supply and the ground circuit of the 4WD control unit. Refer to [DLN-59, "Diagnosis Procedure"](#).

Is the inspection result normal?

- YES (Present error)>>Replace the 4WD control unit. Refer to [DLN-71, "Removal and Installation"](#).
YES (Past error)>>Error was detected in the 4WD control unit branch line.
NO >> Repair the power supply and the ground circuit.

A
B
C
D
E
F
G
H
I
J
K
L
N
O
P

LAN

PWBD BRANCH LINE CIRCUIT

< DTC/CIRCUIT DIAGNOSIS >

[CAN SYSTEM (TYPE 7)]

PWBD BRANCH LINE CIRCUIT

Diagnosis Procedure

INFOID:000000008970651

1. CHECK CONNECTOR

1. Turn the ignition switch OFF.
2. Disconnect the battery cable from the negative terminal.
3. Check the following terminals and connectors for damage, bend and loose connection (unit side and connector side).
 - Automatic back door control module
 - CAN gateway (Models with around view monitor)

Is the inspection result normal?

- YES-1 >> Models with around view monitor: GO TO 2.
YES-2 >> Models without around view monitor: GO TO 3.
NO >> Repair the terminal and connector.

2. CHECK HARNESS CONTINUITY (OPEN CIRCUIT)

1. Disconnect the connector of CAN gateway.
2. Check the continuity between the CAN gateway harness connector terminals.

CAN gateway harness connector		Continuity	
Connector No.	Terminal No.		
M5	4	6	Existed
	10	12	Existed

Is the inspection result normal?

- YES >> GO TO 3.
NO >> Check the harness and repair the root cause (CAN communication circuit 2 side).

3. CHECK HARNESS FOR OPEN CIRCUIT

1. Connect the connector of CAN gateway. (Models with around view monitor)
2. Disconnect the connector of automatic back door control module.
3. Check the resistance between the automatic back door control module harness connector terminals.

Automatic back door control module harness connector		Resistance (Ω)	
Connector No.	Terminal No.		
B55	24	12	Approx. 54 – 66

Is the measurement value within the specification?

- YES >> GO TO 4.
NO >> Replace the body harness.

4. CHECK POWER SUPPLY AND GROUND CIRCUIT

Check the power supply and the ground circuit of the automatic back door control module. Refer to [DLK-160, "AUTOMATIC BACK DOOR CONTROL UNIT : Diagnosis Procedure"](#).

Is the inspection result normal?

- YES (Present error)>>Replace the automatic back door control module. Refer to [DLK-317, "Removal and Installation"](#).
YES (Past error)>>Error was detected in the automatic back door control module branch line.
NO >> Repair the power supply and the ground circuit.

BCM BRANCH LINE CIRCUIT

< DTC/CIRCUIT DIAGNOSIS >

[CAN SYSTEM (TYPE 7)]

BCM BRANCH LINE CIRCUIT

Diagnosis Procedure

INFOID:000000008970652

1. CHECK CONNECTOR

1. Turn the ignition switch OFF.
2. Disconnect the battery cable from the negative terminal.
3. Check the following terminals and connectors for damage, bend and loose connection (unit side and connector side).
 - BCM
 - Harness connector M84 (Models without around view monitor)
 - Harness connector B101 (Models without around view monitor)
 - Harness connector B124 (Models without around view monitor)
 - Harness connector B32 (Models without around view monitor)
 - Harness connector B69 (2WD models without automatic back door system)
 - Harness connector M40 (2WD models without automatic back door system)

Is the inspection result normal?

YES >> GO TO 2.

NO >> Repair the terminal and connector.

2. CHECK HARNESS FOR OPEN CIRCUIT

1. Disconnect the connector of BCM.
2. Check the resistance between the BCM harness connector terminals.

BCM harness connector			Resistance (Ω)
Connector No.	Terminal No.		
M19	60	59	Approx. 108 – 132

Is the measurement value within the specification?

YES >> GO TO 3.

NO >> Repair the BCM branch line.

3. CHECK POWER SUPPLY AND GROUND CIRCUIT

Check the power supply and the ground circuit of the BCM. Refer to [BCS-72, "Diagnosis Procedure"](#).

Is the inspection result normal?

YES (Present error)>>Replace the BCM. Refer to [BCS-78, "Removal and Installation"](#).

YES (Past error)>>Error was detected in the BCM branch line.

NO >> Repair the power supply and the ground circuit.

A
B
C
D
E
F
G
H
I
J
K
L

LAN

CAN COMMUNICATION CIRCUIT

< DTC/CIRCUIT DIAGNOSIS >

[CAN SYSTEM (TYPE 7)]

CAN COMMUNICATION CIRCUIT

Diagnosis Procedure

INFOID:000000008970656

1.CONNECTOR INSPECTION

1. Turn the ignition switch OFF.
2. Disconnect the battery cable from the negative terminal.
3. Disconnect all the unit connectors on CAN communication circuit.
4. Check terminals and connectors for damage, bend and loose connection.

Is the inspection result normal?

- YES >> GO TO 2.
NO >> Repair the terminal and connector.

2.CHECK HARNESS CONTINUITY (SHORT CIRCUIT)

Check the continuity between the data link connector terminals.

Data link connector		Continuity
Connector No.	Terminal No.	
M22	6 14	Not existed

Is the inspection result normal?

- YES >> GO TO 3.
NO >> Check the harness and repair the root cause.

3.CHECK HARNESS CONTINUITY (SHORT CIRCUIT)

Check the continuity between the data link connector and the ground.

Data link connector		Ground	Continuity
Connector No.	Terminal No.		
M22	6		Not existed
	14		Not existed

Is the inspection result normal?

- YES >> GO TO 4.
NO >> Check the harness and repair the root cause.

4.CHECK ECM AND BCM TERMINATION CIRCUIT

1. Remove the ECM and the BCM.
2. Check the resistance between the ECM terminals.

ECM		Resistance (Ω)
Terminal No.		
114	113	Approx. 108 – 132

3. Check the resistance between the BCM terminals.

BCM		Resistance (Ω)
Terminal No.		
60	59	Approx. 108 – 132

Is the measurement value within the specification?

- YES >> GO TO 5.
NO >> Replace the ECM and/or the BCM.

5.CHECK SYMPTOM

Connect all the connectors. Check if the symptoms described in the “Symptom (Results from interview with customer)” are reproduced.

CAN COMMUNICATION CIRCUIT

< DTC/CIRCUIT DIAGNOSIS >

[CAN SYSTEM (TYPE 7)]

Inspection result

Reproduced>>GO TO 6.

Non-reproduced>>Start the diagnosis again. Follow the trouble diagnosis procedure when past error is detected.

6.CHECK UNIT REPRODUCTION

Perform the reproduction test as per the following procedure for each unit.

1. Turn the ignition switch OFF.
2. Disconnect the battery cable from the negative terminal.
3. Disconnect one of the unit connectors of CAN communication circuit.

NOTE:

ECM and BCM have a termination circuit. Check other units first.

4. Connect the battery cable to the negative terminal. Check if the symptoms described in the “Symptom (Results from interview with customer)” are reproduced.

NOTE:

Although unit-related error symptoms occur, do not confuse them with other symptoms.

Inspection result

Reproduced>>Connect the connector. Check other units as per the above procedure.

Non-reproduced>>Replace the unit whose connector was disconnected.

A

B

C

D

E

F

G

H

I

J

K

L

LAN

N

O

P

MAIN LINE BETWEEN IPDM-E AND ABS CIRCUIT

< DTC/CIRCUIT DIAGNOSIS >

[CAN SYSTEM (TYPE 8)]

DTC/CIRCUIT DIAGNOSIS

MAIN LINE BETWEEN IPDM-E AND ABS CIRCUIT

Diagnosis Procedure

INFOID:000000008970659

1. CHECK HARNESS CONTINUITY (OPEN CIRCUIT)

1. Turn the ignition switch OFF.
2. Disconnect the battery cable from the negative terminal.
3. Disconnect the following harness connectors.
 - ECM
 - IPDM E/R
 - ABS actuator and electric unit (control unit)
4. Check the continuity between the IPDM E/R harness connector and the ABS actuator and electric unit (control unit) harness connector.

IPDM E/R harness connector		ABS actuator and electric unit (control unit) harness connector		Continuity
Connector No.	Terminal No.	Connector No.	Terminal No.	
E119	29	E125	25	Existed
	28		15	Existed

Is the inspection result normal?

YES (Present error)>>Check CAN system type decision again.

YES (Past error)>>Error was detected in the main line between the IPDM E/R and the ABS actuator and electric unit (control unit).

NO >> Repair the main line between the IPDM E/R and the ABS actuator and electric unit (control unit).

MAIN LINE BETWEEN ABS AND DLC CIRCUIT

< DTC/CIRCUIT DIAGNOSIS >

[CAN SYSTEM (TYPE 8)]

MAIN LINE BETWEEN ABS AND DLC CIRCUIT

Diagnosis Procedure

INFOID:000000008970660

1.CHECK CONNECTOR

1. Turn the ignition switch OFF.
2. Disconnect the battery cable from the negative terminal.
3. Check the following terminals and connectors for damage, bend and loose connection (connector side and harness side).
 - Harness connector E152
 - Harness connector M31

Is the inspection result normal?

YES >> GO TO 2.

NO >> Repair the terminal and connector.

2.CHECK HARNESS CONTINUITY (OPEN CIRCUIT)

1. Disconnect the following harness connectors.
 - ABS actuator and electric unit (control unit)
 - Harness connectors E152 and M31.
2. Check the continuity between the ABS actuator and electric unit (control unit) harness connector and the harness connector.

ABS actuator and electric unit (control unit) harness connector		Harness connector		Continuity
Connector No.	Terminal No.	Connector No.	Terminal No.	
E125	25	E152	36G	Existed
	15		35G	Existed

Is the inspection result normal?

YES >> GO TO 3.

NO >> Repair the main line between the ABS actuator and electric unit (control unit) and the harness connector E152.

3.CHECK HARNESS CONTINUITY (OPEN CIRCUIT)

Check the continuity between the harness connector and the data link connector.

Harness connector		Data link connector		Continuity
Connector No.	Terminal No.	Connector No.	Terminal No.	
M31	36G	M22	6	Existed
	35G		14	Existed

Is the inspection result normal?

YES (Present error)>>Check CAN system type decision again.

YES (Past error)>>Error was detected in the main line between the ABS actuator and electric unit (control unit) and the data link connector.

NO >> Repair the main line between the harness connector M31 and the data link connector.

A
B
C
D
E
F
G
H
I
J
K
L
LAN
N
O
P

MAIN LINE BETWEEN DLC AND ADP CIRCUIT

< DTC/CIRCUIT DIAGNOSIS >

[CAN SYSTEM (TYPE 8)]

MAIN LINE BETWEEN DLC AND ADP CIRCUIT

Diagnosis Procedure

INFOID:000000008970664

1.CHECK CONNECTOR

1. Turn the ignition switch OFF.
2. Disconnect the battery cable from the negative terminal.
3. Check the following terminals and connectors for damage, bend and loose connection (connector side and harness side).
 - Harness connector M40
 - Harness connector B69

Is the inspection result normal?

YES >> GO TO 2.

NO >> Repair the terminal and connector.

2.CHECK HARNESS CONTINUITY (OPEN CIRCUIT)

1. Disconnect the harness connectors M40 and B69.
2. Check the continuity between the data link connector and the harness connector.
 - Without around view monitor

Data link connector		Harness connector		Continuity
Connector No.	Terminal No.	Connector No.	Terminal No.	
M22	6	M40	89A	Existed
	14		90A	Existed

- With around view monitor

Data link connector		Harness connector		Continuity
Connector No.	Terminal No.	Connector No.	Terminal No.	
M22	13	M40	89A	Existed
	12		90A	Existed

Is the inspection result normal?

YES >> GO TO 3.

NO >> Repair the main line between the data link connector and the harness connector M40.

3.CHECK HARNESS CONTINUITY (OPEN CIRCUIT)

1. Disconnect the harness connectors B54 and B200.
2. Check the continuity between the harness connectors

Harness connector		Harness connector		Continuity
Connector No.	Terminal No.	Connector No.	Terminal No.	
B69	89A	B54	2	Existed
	90A		1	Existed

Is the inspection result normal?

YES (Present error)>>Check CAN system type decision again.

YES (Past error)>>Error was detected in the main line between the data link connector and the driver seat control unit.

NO >> Repair the main line between the harness connectors B69 and B54.

MAIN LINE BETWEEN ADP AND PWBD CIRCUIT

< DTC/CIRCUIT DIAGNOSIS >

[CAN SYSTEM (TYPE 8)]

MAIN LINE BETWEEN ADP AND PWBD CIRCUIT

Diagnosis Procedure

INFOID:000000008970665

1. CHECK HARNESS CONTINUITY (OPEN CIRCUIT)

1. Turn the ignition switch OFF.
2. Disconnect the battery cable from the negative terminal.
3. Disconnect the following harness connectors.
 - ECM (Models without around view monitor)
 - CAN gateway (Models with around view monitor)
 - Harness connector B54 and B200
 - Automatic back door control module
4. Check the continuity between the harness connector and the automatic back door control module harness connector.

Harness connector		Automatic back door control module harness connector		Continuity
Connector No.	Terminal No.	Connector No.	Terminal No.	
B54	1	B55	24	Existed
	2		12	Existed

Is the inspection result normal?

YES (Present error)>>Check CAN system type decision again.

YES (Past error)>>Error was detected in the main line between the driver seat control unit and the automatic back door control module.

NO >> Repair the main line between the harness connector B54 and the automatic back door control module.

A
B
C
D
E
F
G
H
I
J
K
L
N
O
P

LAN

ECM BRANCH LINE CIRCUIT

< DTC/CIRCUIT DIAGNOSIS >

[CAN SYSTEM (TYPE 8)]

ECM BRANCH LINE CIRCUIT

Diagnosis Procedure

INFOID:000000008970667

1. CHECK CONNECTOR

1. Turn the ignition switch OFF.
2. Disconnect the battery cable from the negative terminal.
3. Check the terminals and connectors of the ECM for damage, bend and loose connection (unit side and connector side).

Is the inspection result normal?

- YES >> GO TO 2.
NO >> Repair the terminal and connector.

2. CHECK HARNESS FOR OPEN CIRCUIT

1. Disconnect the connector of ECM.
2. Check the resistance between the ECM harness connector terminals.

ECM harness connector			Resistance (Ω)
Connector No.	Terminal No.		
E16	114	113	Approx. 108 – 132

Is the measurement value within the specification?

- YES >> GO TO 3.
NO >> Repair the ECM branch line.

3. CHECK POWER SUPPLY AND GROUND CIRCUIT

Check the power supply and the ground circuit of the ECM. Refer to [EC-170, "Diagnosis Procedure"](#).

Is the inspection result normal?

- YES (Present error)>>Replace the ECM. Refer to [EC-460, "Removal and Installation"](#).
YES (Past error)>>Error was detected in the ECM branch line.
NO >> Repair the power supply and the ground circuit.

IPDM-E BRANCH LINE CIRCUIT

< DTC/CIRCUIT DIAGNOSIS >

[CAN SYSTEM (TYPE 8)]

IPDM-E BRANCH LINE CIRCUIT

Diagnosis Procedure

INFOID:000000008970668

1. CHECK CONNECTOR

1. Turn the ignition switch OFF.
2. Disconnect the battery cable from the negative terminal.
3. Check the terminals and connectors of the IPDM E/R for damage, bend and loose connection (unit side and connector side).

Is the inspection result normal?

- YES >> GO TO 2.
NO >> Repair the terminal and connector.

2. CHECK HARNESS FOR OPEN CIRCUIT

1. Disconnect the connector of IPDM E/R.
2. Check the resistance between the IPDM E/R harness connector terminals.

IPDM E/R harness connector			Resistance (Ω)
Connector No.	Terminal No.		
E119	29	28	Approx. 54 – 66

Is the measurement value within the specification?

- YES >> GO TO 3.
NO >> Repair the IPDM E/R branch line.

3. CHECK POWER SUPPLY AND GROUND CIRCUIT

Check the power supply and the ground circuit of the IPDM E/R. Refer to [PCS-31, "Diagnosis Procedure"](#).

Is the inspection result normal?

- YES (Present error)>>Replace the IPDM E/R. Refer to [PCS-32, "Removal and Installation"](#).
YES (Past error)>>Error was detected in the IPDM E/R branch line.
NO >> Repair the power supply and the ground circuit.

A
B
C
D
E
F
G
H
I
J
K
L

LAN

TCM BRANCH LINE CIRCUIT

< DTC/CIRCUIT DIAGNOSIS >

[CAN SYSTEM (TYPE 8)]

TCM BRANCH LINE CIRCUIT

Diagnosis Procedure

INFOID:000000008970669

1. CHECK CONNECTOR

1. Turn the ignition switch OFF.
2. Disconnect the battery cable from the negative terminal.
3. Check the following terminals and connectors for damage, bend and loose connection (unit side and connector side).
 - TCM
 - Harness connector F32
 - Harness connector E2

Is the inspection result normal?

YES >> GO TO 2.

NO >> Repair the terminal and connector.

2. CHECK HARNESS FOR OPEN CIRCUIT

1. Disconnect the connector of TCM.
2. Check the resistance between the TCM harness connector terminals.

TCM harness connector			Resistance (Ω)
Connector No.	Terminal No.		
F15	33	23	Approx. 54 – 66

Is the measurement value within the specification?

YES >> GO TO 3.

NO >> Repair the TCM branch line.

3. CHECK POWER SUPPLY AND GROUND CIRCUIT

Check the power supply and the ground circuit of the TCM. Refer to [TM-165, "Diagnosis Procedure"](#).

Is the inspection result normal?

YES (Present error)>>Replace the TCM. Refer to [TM-197, "Removal and Installation"](#).

YES (Past error)>>Error was detected in the TCM branch line.

NO >> Repair the power supply and the ground circuit.

ABS BRANCH LINE CIRCUIT

< DTC/CIRCUIT DIAGNOSIS >

[CAN SYSTEM (TYPE 8)]

ABS BRANCH LINE CIRCUIT

Diagnosis Procedure

INFOID:000000008970670

1. CHECK CONNECTOR

1. Turn the ignition switch OFF.
2. Disconnect the battery cable from the negative terminal.
3. Check the terminals and connectors of the ABS actuator and electric unit (control unit) for damage, bend and loose connection (unit side and connector side).

Is the inspection result normal?

- YES >> GO TO 2.
NO >> Repair the terminal and connector.

2. CHECK HARNESS FOR OPEN CIRCUIT

1. Disconnect the connector of ABS actuator and electric unit (control unit).
2. Check the resistance between the ABS actuator and electric unit (control unit) harness connector terminals.

ABS actuator and electric unit (control unit) harness connector			Resistance (Ω)
Connector No.	Terminal No.		
E125	25	15	Approx. 54 – 66

Is the measurement value within the specification?

- YES >> GO TO 3.
NO >> Repair the ABS actuator and electric unit (control unit) branch line.

3. CHECK POWER SUPPLY AND GROUND CIRCUIT

Check the power supply and the ground circuit of the ABS actuator and electric unit (control unit). Refer to [BRC-63, "Diagnosis Procedure"](#).

Is the inspection result normal?

- YES (Present error)>>Replace the ABS actuator and electric unit (control unit). Refer to [BRC-121, "Removal and Installation"](#).
YES (Past error)>>Error was detected in the ABS actuator and electric unit (control unit) branch line.
NO >> Repair the power supply and the ground circuit.

A
B
C
D
E
F
G
H
I
J
K
L

LAN

EPS BRANCH LINE CIRCUIT

< DTC/CIRCUIT DIAGNOSIS >

[CAN SYSTEM (TYPE 8)]

EPS BRANCH LINE CIRCUIT

Diagnosis Procedure

INFOID:000000008970671

1. CHECK CONNECTOR

1. Turn the ignition switch OFF.
2. Disconnect the battery cable from the negative terminal.
3. Check the terminals and connectors of the power steering control module for damage, bend and loose connection (unit side and connector side).

Is the inspection result normal?

- YES >> GO TO 2.
NO >> Repair the terminal and connector.

2. CHECK HARNESS FOR OPEN CIRCUIT

1. Disconnect the connector of power steering control module.
2. Check the resistance between the power steering control module harness connector terminals.

Power steering control module harness connector			Resistance (Ω)
Connector No.	Terminal No.		
E62	8	7	Approx. 54 – 66

Is the measurement value within the specification?

- YES >> GO TO 3.
NO >> Repair the power steering control module branch line.

3. CHECK POWER SUPPLY AND GROUND CIRCUIT

Check the power supply and the ground circuit of the power steering control module. Refer to [STC-22, "Diagnosis Procedure"](#).

Is the inspection result normal?

- YES (Present error)>>Replace the power steering oil pump assembly. Refer to [ST-51, "Removal and Installation"](#).
YES (Past error)>>Error was detected in the power steering control module branch line.
NO >> Repair the power supply and the ground circuit.

A-BAG BRANCH LINE CIRCUIT

< DTC/CIRCUIT DIAGNOSIS >

[CAN SYSTEM (TYPE 8)]

A-BAG BRANCH LINE CIRCUIT

Diagnosis Procedure

INFOID:000000008970672

WARNING:

- Before servicing, turn ignition switch OFF, disconnect battery negative terminal, and wait 3 minutes or more. (To discharge backup capacitor.)
- Never use unspecified tester or other measuring device.

1. CHECK CONNECTOR

1. Turn the ignition switch OFF.
2. Disconnect the battery cable from the negative terminal.
3. Check the terminals and connectors of the air bag diagnosis sensor unit for damage, bend and loose connection (unit side and connector side).

Is the inspection result normal?

YES >> GO TO 2.

NO >> Replace the main harness.

2. CHECK AIR BAG DIAGNOSIS SENSOR UNIT

Check the air bag diagnosis sensor unit. Refer to [SRC-40, "Work Flow"](#).

Is the inspection result normal?

YES >> Replace the main harness.

NO >> Replace parts whose air bag system has a malfunction.

A
B
C
D
E
F
G
H
I
J
K
L
LAN
N
O
P

AV BRANCH LINE CIRCUIT

< DTC/CIRCUIT DIAGNOSIS >

[CAN SYSTEM (TYPE 8)]

AV BRANCH LINE CIRCUIT

Diagnosis Procedure

INFOID:000000008970673

1. CHECK CONNECTOR

1. Turn the ignition switch OFF.
2. Disconnect the battery cable from the negative terminal.
3. Check the terminals and connectors of the AV control unit for damage, bend and loose connection (unit side and connector side).

Is the inspection result normal?

- YES >> GO TO 2.
NO >> Repair the terminal and connector.

2. CHECK HARNESS FOR OPEN CIRCUIT

1. Disconnect the connector of AV control unit.
 2. Check the resistance between the AV control unit harness connector terminals.
- With BOSE audio without navigation

AV control unit harness connector			Resistance (Ω)
Connector No.	Terminal No.		
M42	11	12	Approx. 54 – 66

- Without BOSE audio with navigation

AV control unit harness connector			Resistance (Ω)
Connector No.	Terminal No.		
M124	11	12	Approx. 54 – 66

- With BOSE audio with navigation

AV control unit harness connector			Resistance (Ω)
Connector No.	Terminal No.		
M163	78	62	Approx. 54 – 66

Is the measurement value within the specification?

- YES >> GO TO 3.
NO >> Repair the AV control unit branch line.

3. CHECK POWER SUPPLY AND GROUND CIRCUIT

Check the power supply and the ground circuit of the AV control unit. Refer to the following.

- Mid audio without BOSE: [AV-143. "AV CONTROL UNIT : Diagnosis Procedure"](#)
- Mid audio with BOSE: [AV-303. "AV CONTROL UNIT : Diagnosis Procedure"](#)
- Premium audio with navigation: [AV-532. "AV CONTROL UNIT : Diagnosis Procedure"](#)

Is the inspection result normal?

- YES (Present error)>>Replace the AV control unit. Refer to the following.
- Mid audio without BOSE: [AV-186. "Removal and Installation"](#)
 - Mid audio with BOSE: [AV-357. "Removal and Installation"](#)
 - Premium audio with navigation: [AV-585. "Removal and Installation"](#)

YES (Past error)>>Error was detected in the AV control unit branch line.

NO >> Repair the power supply and the ground circuit.

DLC BRANCH LINE CIRCUIT

< DTC/CIRCUIT DIAGNOSIS >

[CAN SYSTEM (TYPE 8)]

DLC BRANCH LINE CIRCUIT

Diagnosis Procedure

INFOID:000000008970674

1. CHECK CONNECTOR

1. Turn the ignition switch OFF.
2. Disconnect the battery cable from the negative terminal.
3. Check the terminals and connectors of the data link connector for damage, bend and loose connection (connector side and harness side).

Is the inspection result normal?

- YES >> GO TO 2.
NO >> Repair the terminal and connector.

2. CHECK HARNESS FOR OPEN CIRCUIT

Check the resistance between the data link connector terminals.

Data link connector			Resistance (Ω)
Connector No.	Terminal No.		
M22	6	14	Approx. 54 – 66

Is the measurement value within the specification?

- YES (Present error)>>Check CAN system type decision again.
YES (Past error)>>Error was detected in the data link connector branch line circuit.
NO >> Repair the data link connector branch line.

A
B
C
D
E
F
G
H
I
J
K
L
N
O
P

LAN

HVAC BRANCH LINE CIRCUIT

< DTC/CIRCUIT DIAGNOSIS >

[CAN SYSTEM (TYPE 8)]

HVAC BRANCH LINE CIRCUIT

Diagnosis Procedure

INFOID:000000008970677

1. CHECK CONNECTOR

1. Turn the ignition switch OFF.
2. Disconnect the battery cable from the negative terminal.
3. Check the terminals and connectors of the A/C auto amp. for damage, bend and loose connection (unit side and connector side).

Is the inspection result normal?

- YES >> GO TO 2.
NO >> Repair the terminal and connector.

2. CHECK HARNESS FOR OPEN CIRCUIT

1. Disconnect the connector of A/C auto amp.
2. Check the resistance between the A/C auto amp. harness connector terminals.

A/C auto amp. harness connector			Resistance (Ω)
Connector No.	Terminal No.		
M50	1	21	Approx. 54 – 66

Is the measurement value within the specification?

- YES >> GO TO 3.
NO >> Repair the A/C auto amp. branch line.

3. CHECK POWER SUPPLY AND GROUND CIRCUIT

Check the power supply and the ground circuit of the A/C auto amp. Refer to [HAC-113, "A/C AUTO AMP. : Diagnosis Procedure"](#).

Is the inspection result normal?

- YES (Present error)>>Replace the A/C auto amp. Refer to [HAC-156, "Removal and Installation"](#).
YES (Past error)>>Error was detected in the A/C auto amp. branch line.
NO >> Repair the power supply and the ground circuit.

M&A BRANCH LINE CIRCUIT

Diagnosis Procedure

INFOID:000000008970678

1.CHECK CONNECTOR

1. Turn the ignition switch OFF.
2. Disconnect the battery cable from the negative terminal.
3. Check the terminals and connectors of the combination meter for damage, bend and loose connection (unit side and connector side).

Is the inspection result normal?

- YES >> GO TO 2.
 NO >> Repair the terminal and connector.

2.CHECK HARNESS FOR OPEN CIRCUIT

1. Disconnect the connector of combination meter.
2. Check the resistance between the combination meter harness connector terminals.

Combination meter harness connector			Resistance (Ω)
Connector No.	Terminal No.		
M24	39	38	Approx. 54 – 66

Is the measurement value within the specification?

- YES >> GO TO 3.
 NO >> Repair the combination meter branch line.

3.CHECK POWER SUPPLY AND GROUND CIRCUIT

Check the power supply and the ground circuit of the combination meter. Refer to [MWI-59, "COMBINATION METER : Diagnosis Procedure"](#).

Is the inspection result normal?

- YES (Present error)>>Replace the combination meter. Refer to [MWI-82, "Removal and Installation"](#).
 YES (Past error)>>Error was detected in the combination meter branch line.
 NO >> Repair the power supply and the ground circuit.

A
B
C
D
E
F
G
H
I
J
K
L

LAN

SONAR BRANCH LINE CIRCUIT

< DTC/CIRCUIT DIAGNOSIS >

[CAN SYSTEM (TYPE 8)]

SONAR BRANCH LINE CIRCUIT

Diagnosis Procedure

INFOID:000000008970679

1. CHECK CONNECTOR

1. Turn the ignition switch OFF.
2. Disconnect the battery cable from the negative terminal.
3. Check the terminals and connectors of sonar control unit for damage, bend and loose connection (unit side and connector side).

Is the inspection result normal?

- YES >> GO TO 2.
NO >> Repair the terminal and connector.

2. CHECK HARNESS FOR OPEN CIRCUIT

1. Disconnect the connector of sonar control unit.
2. Check the resistance between the sonar control unit harness connector terminals.

Sonar control unit harness connector			Resistance (Ω)
Connector No.	Terminal No.		
M70	5	6	Approx. 54 – 66

Is the measurement value within the specification?

- YES >> GO TO 3.
NO >> Replace the main harness.

3. CHECK POWER SUPPLY AND GROUND CIRCUIT

Check the power supply and the ground circuit of the sonar control unit. Refer to [SN-32, "Diagnosis Procedure"](#).

Is the inspection result normal?

- YES (Present error)>>Replace the sonar control unit. Refer to [SN-34, "Removal and Installation"](#).
YES (Past error)>>Error was detected in the sonar control unit branch line.
NO >> Repair the power supply and the ground circuit.

STRG BRANCH LINE CIRCUIT

< DTC/CIRCUIT DIAGNOSIS >

[CAN SYSTEM (TYPE 8)]

STRG BRANCH LINE CIRCUIT

Diagnosis Procedure

INFOID:000000008970680

1. CHECK CONNECTOR

1. Turn the ignition switch OFF.
2. Disconnect the battery cable from the negative terminal.
3. Check the terminals and connectors of the steering angle sensor for damage, bend and loose connection (unit side and connector side).

Is the inspection result normal?

- YES >> GO TO 2.
NO >> Repair the terminal and connector.

2. CHECK HARNESS FOR OPEN CIRCUIT

1. Disconnect the connector of steering angle sensor.
2. Check the resistance between the steering angle sensor harness connector terminals.

Steering angle sensor harness connector			Resistance (Ω)
Connector No.	Terminal No.		
M54	5	2	Approx. 54 – 66

Is the measurement value within the specification?

- YES >> GO TO 3.
NO >> Repair the steering angle sensor branch line.

3. CHECK POWER SUPPLY AND GROUND CIRCUIT

Check the power supply and the ground circuit of the steering angle sensor. Refer to [BRC-44, "Wiring Diagram"](#).

Is the inspection result normal?

- YES (Present error)>>Replace the steering angle sensor. Refer to [BRC-124, "Removal and Installation"](#).
YES (Past error)>>Error was detected in the steering angle sensor branch line.
NO >> Repair the power supply and the ground circuit.

A
B
C
D
E
F
G
H
I
J
K
L

LAN

N
O
P

ADP BRANCH LINE CIRCUIT

< DTC/CIRCUIT DIAGNOSIS >

[CAN SYSTEM (TYPE 8)]

ADP BRANCH LINE CIRCUIT

Diagnosis Procedure

INFOID:000000008970681

1. CHECK CONNECTOR

1. Turn the ignition switch OFF.
2. Disconnect the battery cable from the negative terminal.
3. Check the following terminals and connectors for damage, bend and loose connection (unit side and connector side).
 - Driver seat control unit
 - Harness connector B200
 - Harness connector B54
 - CAN gateway (Models with around view monitor)

Is the inspection result normal?

- YES-1 >> Models with around view monitor: GO TO 2.
YES-2 >> Models without around view monitor: GO TO 3.
NO >> Repair the terminal and connector.

2. CHECK HARNESS CONTINUITY (OPEN CIRCUIT)

1. Disconnect the connector of CAN gateway.
2. Check the continuity between the CAN gateway harness connector terminals.

CAN gateway harness connector			Continuity
Connector No.	Terminal No.		
M5	4	6	Existed
	10	12	Existed

Is the inspection result normal?

- YES >> GO TO 3.
NO >> Check the harness and repair the root cause (CAN communication circuit 2 side).

3. CHECK HARNESS FOR OPEN CIRCUIT

1. Connect the connector of CAN gateway. (Models with around view monitor)
2. Disconnect the connector of driver seat control unit.
3. Check the resistance between the driver seat control unit harness connector terminals.

Driver seat control unit harness connector			Resistance (Ω)
Connector No.	Terminal No.		
B209	16	32	Approx. 54 – 66

Is the measurement value within the specification?

- YES >> GO TO 4.
NO >> Repair the driver seat control unit branch line.

4. CHECK POWER SUPPLY AND GROUND CIRCUIT

Check the power supply and the ground circuit of the driver seat control unit. Refer to [ADP-83, "DRIVER SEAT CONTROL UNIT : Diagnosis Procedure"](#).

Is the inspection result normal?

- YES (Present error)>>Replace the driver seat control unit. Refer to [ADP-156, "Removal and Installation"](#).
YES (Past error)>>Error was detected in the driver seat control unit branch line.
NO >> Repair the power supply and the ground circuit.

4WD BRANCH LINE CIRCUIT

< DTC/CIRCUIT DIAGNOSIS >

[CAN SYSTEM (TYPE 8)]

4WD BRANCH LINE CIRCUIT

Diagnosis Procedure

INFOID:000000008970682

1. CHECK CONNECTOR

1. Turn the ignition switch OFF.
2. Disconnect the battery cable from the negative terminal.
3. Check the following terminals and connectors for damage, bend and loose connection (unit side and connector side).
 - 4WD control unit
 - CAN gateway (Models with around view monitor)

Is the inspection result normal?

- YES-1 >> Models with around view monitor: GO TO 2.
YES-2 >> Models without around view monitor: GO TO 3.
NO >> Repair the terminal and connector.

2. CHECK HARNESS CONTINUITY (OPEN CIRCUIT)

1. Disconnect the connector of CAN gateway.
2. Check the continuity between the CAN gateway harness connector terminals.

CAN gateway harness connector		Continuity	
Connector No.	Terminal No.		
M5	4	6	Existed
	10	12	Existed

Is the inspection result normal?

- YES >> GO TO 3.
NO >> Check the harness and repair the root cause (CAN communication circuit 2 side).

3. CHECK HARNESS FOR OPEN CIRCUIT

1. Connect the connector of CAN gateway. (Models with around view monitor)
2. Disconnect the connector of 4WD control unit.
3. Check the resistance between the 4WD control unit harness connector terminals.

4WD control unit harness connector		Resistance (Ω)	
Connector No.	Terminal No.		
B67	8	16	Approx. 54 – 66

Is the measurement value within the specification?

- YES >> GO TO 4.
NO >> Repair the 4WD control unit branch line.

4. CHECK POWER SUPPLY AND GROUND CIRCUIT

Check the power supply and the ground circuit of the 4WD control unit. Refer to [DLN-59, "Diagnosis Procedure"](#).

Is the inspection result normal?

- YES (Present error)>>Replace the 4WD control unit. Refer to [DLN-71, "Removal and Installation"](#).
YES (Past error)>>Error was detected in the 4WD control unit branch line.
NO >> Repair the power supply and the ground circuit.

A
B
C
D
E
F
G
H
I
J
K
L
N
O
P

LAN

PWBD BRANCH LINE CIRCUIT

< DTC/CIRCUIT DIAGNOSIS >

[CAN SYSTEM (TYPE 8)]

PWBD BRANCH LINE CIRCUIT

Diagnosis Procedure

INFOID:000000008970683

1. CHECK CONNECTOR

1. Turn the ignition switch OFF.
2. Disconnect the battery cable from the negative terminal.
3. Check the following terminals and connectors for damage, bend and loose connection (unit side and connector side).
 - Automatic back door control module
 - CAN gateway (Models with around view monitor)

Is the inspection result normal?

- YES-1 >> Models with around view monitor: GO TO 2.
YES-2 >> Models without around view monitor: GO TO 3.
NO >> Repair the terminal and connector.

2. CHECK HARNESS CONTINUITY (OPEN CIRCUIT)

1. Disconnect the connector of CAN gateway.
2. Check the continuity between the CAN gateway harness connector terminals.

CAN gateway harness connector		Continuity	
Connector No.	Terminal No.		
M5	4	6	Existed
	10	12	Existed

Is the inspection result normal?

- YES >> GO TO 3.
NO >> Check the harness and repair the root cause (CAN communication circuit 2 side).

3. CHECK HARNESS FOR OPEN CIRCUIT

1. Connect the connector of CAN gateway. (Models with around view monitor)
2. Disconnect the connector of automatic back door control module.
3. Check the resistance between the automatic back door control module harness connector terminals.

Automatic back door control module harness connector		Resistance (Ω)	
Connector No.	Terminal No.		
B55	24	12	Approx. 54 – 66

Is the measurement value within the specification?

- YES >> GO TO 4.
NO >> Replace the body harness.

4. CHECK POWER SUPPLY AND GROUND CIRCUIT

Check the power supply and the ground circuit of the automatic back door control module. Refer to [DLK-160, "AUTOMATIC BACK DOOR CONTROL UNIT : Diagnosis Procedure"](#).

Is the inspection result normal?

- YES (Present error)>>Replace the automatic back door control module. Refer to [DLK-317, "Removal and Installation"](#).
YES (Past error)>>Error was detected in the automatic back door control module branch line.
NO >> Repair the power supply and the ground circuit.

BCM BRANCH LINE CIRCUIT

< DTC/CIRCUIT DIAGNOSIS >

[CAN SYSTEM (TYPE 8)]

BCM BRANCH LINE CIRCUIT

Diagnosis Procedure

INFOID:000000008970684

1. CHECK CONNECTOR

1. Turn the ignition switch OFF.
2. Disconnect the battery cable from the negative terminal.
3. Check the following terminals and connectors for damage, bend and loose connection (unit side and connector side).
 - BCM
 - Harness connector M84 (Models without around view monitor)
 - Harness connector B101 (Models without around view monitor)
 - Harness connector B124 (Models without around view monitor)
 - Harness connector B32 (Models without around view monitor)
 - Harness connector B69 (2WD models without automatic back door system)
 - Harness connector M40 (2WD models without automatic back door system)

Is the inspection result normal?

YES >> GO TO 2.

NO >> Repair the terminal and connector.

2. CHECK HARNESS FOR OPEN CIRCUIT

1. Disconnect the connector of BCM.
2. Check the resistance between the BCM harness connector terminals.

BCM harness connector			Resistance (Ω)
Connector No.	Terminal No.		
M19	60	59	Approx. 108 – 132

Is the measurement value within the specification?

YES >> GO TO 3.

NO >> Repair the BCM branch line.

3. CHECK POWER SUPPLY AND GROUND CIRCUIT

Check the power supply and the ground circuit of the BCM. Refer to [BCS-72, "Diagnosis Procedure"](#).

Is the inspection result normal?

YES (Present error)>>Replace the BCM. Refer to [BCS-78, "Removal and Installation"](#).

YES (Past error)>>Error was detected in the BCM branch line.

NO >> Repair the power supply and the ground circuit.

A
B
C
D
E
F
G
H
I
J
K
L

LAN

CAN COMMUNICATION CIRCUIT

< DTC/CIRCUIT DIAGNOSIS >

[CAN SYSTEM (TYPE 8)]

CAN COMMUNICATION CIRCUIT

Diagnosis Procedure

INFOID:000000008970688

1. CONNECTOR INSPECTION

1. Turn the ignition switch OFF.
2. Disconnect the battery cable from the negative terminal.
3. Disconnect all the unit connectors on CAN communication circuit.
4. Check terminals and connectors for damage, bend and loose connection.

Is the inspection result normal?

- YES >> GO TO 2.
NO >> Repair the terminal and connector.

2. CHECK HARNESS CONTINUITY (SHORT CIRCUIT)

Check the continuity between the data link connector terminals.

Data link connector		Continuity
Connector No.	Terminal No.	
M22	6 14	Not existed

Is the inspection result normal?

- YES >> GO TO 3.
NO >> Check the harness and repair the root cause.

3. CHECK HARNESS CONTINUITY (SHORT CIRCUIT)

Check the continuity between the data link connector and the ground.

Data link connector		Ground	Continuity
Connector No.	Terminal No.		
M22	6		Not existed
	14		Not existed

Is the inspection result normal?

- YES >> GO TO 4.
NO >> Check the harness and repair the root cause.

4. CHECK ECM AND BCM TERMINATION CIRCUIT

1. Remove the ECM and the BCM.
2. Check the resistance between the ECM terminals.

ECM		Resistance (Ω)
Terminal No.		
114	113	Approx. 108 – 132

3. Check the resistance between the BCM terminals.

BCM		Resistance (Ω)
Terminal No.		
60	59	Approx. 108 – 132

Is the measurement value within the specification?

- YES >> GO TO 5.
NO >> Replace the ECM and/or the BCM.

5. CHECK SYMPTOM

Connect all the connectors. Check if the symptoms described in the “Symptom (Results from interview with customer)” are reproduced.

CAN COMMUNICATION CIRCUIT

< DTC/CIRCUIT DIAGNOSIS >

[CAN SYSTEM (TYPE 8)]

Inspection result

Reproduced>>GO TO 6.

Non-reproduced>>Start the diagnosis again. Follow the trouble diagnosis procedure when past error is detected.

6.CHECK UNIT REPRODUCTION

Perform the reproduction test as per the following procedure for each unit.

1. Turn the ignition switch OFF.
2. Disconnect the battery cable from the negative terminal.
3. Disconnect one of the unit connectors of CAN communication circuit.

NOTE:

ECM and BCM have a termination circuit. Check other units first.

4. Connect the battery cable to the negative terminal. Check if the symptoms described in the “Symptom (Results from interview with customer)” are reproduced.

NOTE:

Although unit-related error symptoms occur, do not confuse them with other symptoms.

Inspection result

Reproduced>>Connect the connector. Check other units as per the above procedure.

Non-reproduced>>Replace the unit whose connector was disconnected.

A

B

C

D

E

F

G

H

I

J

K

L

LAN

N

O

P

MAIN LINE BETWEEN IPDM-E AND ABS CIRCUIT

< DTC/CIRCUIT DIAGNOSIS >

[CAN SYSTEM (TYPE 9)]

DTC/CIRCUIT DIAGNOSIS

MAIN LINE BETWEEN IPDM-E AND ABS CIRCUIT

Diagnosis Procedure

INFOID:000000008970691

1. CHECK HARNESS CONTINUITY (OPEN CIRCUIT)

1. Turn the ignition switch OFF.
2. Disconnect the battery cable from the negative terminal.
3. Disconnect the following harness connectors.
 - ECM
 - IPDM E/R
 - ABS actuator and electric unit (control unit)
4. Check the continuity between the IPDM E/R harness connector and the ABS actuator and electric unit (control unit) harness connector.

IPDM E/R harness connector		ABS actuator and electric unit (control unit) harness connector		Continuity
Connector No.	Terminal No.	Connector No.	Terminal No.	
E119	29	E125	25	Existed
	28		15	Existed

Is the inspection result normal?

YES (Present error)>>Check CAN system type decision again.

YES (Past error)>>Error was detected in the main line between the IPDM E/R and the ABS actuator and electric unit (control unit).

NO >> Repair the main line between the IPDM E/R and the ABS actuator and electric unit (control unit).

MAIN LINE BETWEEN ABS AND DLC CIRCUIT

< DTC/CIRCUIT DIAGNOSIS >

[CAN SYSTEM (TYPE 9)]

MAIN LINE BETWEEN ABS AND DLC CIRCUIT

Diagnosis Procedure

INFOID:000000008970692

1.CHECK CONNECTOR

1. Turn the ignition switch OFF.
2. Disconnect the battery cable from the negative terminal.
3. Check the following terminals and connectors for damage, bend and loose connection (connector side and harness side).
 - Harness connector E152
 - Harness connector M31

Is the inspection result normal?

YES >> GO TO 2.

NO >> Repair the terminal and connector.

2.CHECK HARNESS CONTINUITY (OPEN CIRCUIT)

1. Disconnect the following harness connectors.
 - ABS actuator and electric unit (control unit)
 - Harness connectors E152 and M31.
2. Check the continuity between the ABS actuator and electric unit (control unit) harness connector and the harness connector.

ABS actuator and electric unit (control unit) harness connector		Harness connector		Continuity
Connector No.	Terminal No.	Connector No.	Terminal No.	
E125	25	E152	36G	Existed
	15		35G	Existed

Is the inspection result normal?

YES >> GO TO 3.

NO >> Repair the main line between the ABS actuator and electric unit (control unit) and the harness connector E152.

3.CHECK HARNESS CONTINUITY (OPEN CIRCUIT)

Check the continuity between the harness connector and the data link connector.

Harness connector		Data link connector		Continuity
Connector No.	Terminal No.	Connector No.	Terminal No.	
M31	36G	M22	6	Existed
	35G		14	Existed

Is the inspection result normal?

YES (Present error)>>Check CAN system type decision again.

YES (Past error)>>Error was detected in the main line between the ABS actuator and electric unit (control unit) and the data link connector.

NO >> Repair the main line between the harness connector M31 and the data link connector.

A
B
C
D
E
F
G
H
I
J
K
L
LAN
N
O
P

MAIN LINE BETWEEN DLC AND ADP CIRCUIT

< DTC/CIRCUIT DIAGNOSIS >

[CAN SYSTEM (TYPE 9)]

MAIN LINE BETWEEN DLC AND ADP CIRCUIT

Diagnosis Procedure

INFOID:000000008970696

1.CHECK CONNECTOR

1. Turn the ignition switch OFF.
2. Disconnect the battery cable from the negative terminal.
3. Check the following terminals and connectors for damage, bend and loose connection (connector side and harness side).
 - Harness connector M40
 - Harness connector B69

Is the inspection result normal?

YES >> GO TO 2.

NO >> Repair the terminal and connector.

2.CHECK HARNESS CONTINUITY (OPEN CIRCUIT)

1. Disconnect the harness connectors M40 and B69.
2. Check the continuity between the data link connector and the harness connector.
 - Without around view monitor

Data link connector		Harness connector		Continuity
Connector No.	Terminal No.	Connector No.	Terminal No.	
M22	6	M40	89A	Existed
	14		90A	Existed

- With around view monitor

Data link connector		Harness connector		Continuity
Connector No.	Terminal No.	Connector No.	Terminal No.	
M22	13	M40	89A	Existed
	12		90A	Existed

Is the inspection result normal?

YES >> GO TO 3.

NO >> Repair the main line between the data link connector and the harness connector M40.

3.CHECK HARNESS CONTINUITY (OPEN CIRCUIT)

1. Disconnect the harness connectors B54 and B200.
2. Check the continuity between the harness connectors

Harness connector		Harness connector		Continuity
Connector No.	Terminal No.	Connector No.	Terminal No.	
B69	89A	B54	2	Existed
	90A		1	Existed

Is the inspection result normal?

YES (Present error)>>Check CAN system type decision again.

YES (Past error)>>Error was detected in the main line between the data link connector and the driver seat control unit.

NO >> Repair the main line between the harness connectors B69 and B54.

MAIN LINE BETWEEN ADP AND PWBD CIRCUIT

< DTC/CIRCUIT DIAGNOSIS >

[CAN SYSTEM (TYPE 9)]

MAIN LINE BETWEEN ADP AND PWBD CIRCUIT

Diagnosis Procedure

INFOID:000000008970697

1. CHECK HARNESS CONTINUITY (OPEN CIRCUIT)

1. Turn the ignition switch OFF.
2. Disconnect the battery cable from the negative terminal.
3. Disconnect the following harness connectors.
 - ECM (Models without around view monitor)
 - CAN gateway (Models with around view monitor)
 - Harness connector B54 and B200
 - Automatic back door control module
4. Check the continuity between the harness connector and the automatic back door control module harness connector.

Harness connector		Automatic back door control module harness connector		Continuity
Connector No.	Terminal No.	Connector No.	Terminal No.	
B54	1	B55	24	Existed
	2		12	Existed

Is the inspection result normal?

YES (Present error)>>Check CAN system type decision again.

YES (Past error)>>Error was detected in the main line between the driver seat control unit and the automatic back door control module.

NO >> Repair the main line between the harness connector B54 and the automatic back door control module.

A
B
C
D
E
F
G
H
I
J
K
L
N
O
P

LAN

MAIN LINE BETWEEN DLC AND CGW CIRCUIT

< DTC/CIRCUIT DIAGNOSIS >

[CAN SYSTEM (TYPE 9)]

MAIN LINE BETWEEN DLC AND CGW CIRCUIT

Diagnosis Procedure

INFOID:000000008970698

1. CHECK HARNESS CONTINUITY (OPEN CIRCUIT)

1. Turn the ignition switch OFF.
2. Disconnect the battery cable from the negative terminal.
3. Disconnect the following harness connectors.
 - ECM
 - CAN gateway
4. Check the continuity between the data link connector and the CAN gateway harness connector.

Data link connector		CAN gateway harness connector		Continuity
Connector No.	Terminal No.	Connector No.	Terminal No.	
M22	6	M5	1	Existed
	14		7	Existed

Is the inspection result normal?

YES (Present error)>>Check CAN system type decision again.

YES (Past error)>>Error was detected in the main line between the data link connector and the CAN gateway.

NO >> Repair the main line between the data link connector and the CAN gateway.

ECM BRANCH LINE CIRCUIT

< DTC/CIRCUIT DIAGNOSIS >

[CAN SYSTEM (TYPE 9)]

ECM BRANCH LINE CIRCUIT

Diagnosis Procedure

INFOID:000000008970699

1. CHECK CONNECTOR

1. Turn the ignition switch OFF.
2. Disconnect the battery cable from the negative terminal.
3. Check the terminals and connectors of the ECM for damage, bend and loose connection (unit side and connector side).

Is the inspection result normal?

- YES >> GO TO 2.
NO >> Repair the terminal and connector.

2. CHECK HARNESS FOR OPEN CIRCUIT

1. Disconnect the connector of ECM.
2. Check the resistance between the ECM harness connector terminals.

ECM harness connector			Resistance (Ω)
Connector No.	Terminal No.		
E16	114	113	Approx. 108 – 132

Is the measurement value within the specification?

- YES >> GO TO 3.
NO >> Repair the ECM branch line.

3. CHECK POWER SUPPLY AND GROUND CIRCUIT

Check the power supply and the ground circuit of the ECM. Refer to [EC-170. "Diagnosis Procedure"](#).

Is the inspection result normal?

- YES (Present error)>>Replace the ECM. Refer to [EC-460. "Removal and Installation"](#).
YES (Past error)>>Error was detected in the ECM branch line.
NO >> Repair the power supply and the ground circuit.

A
B
C
D
E
F
G
H
I
J
K
L

LAN

N
O
P

IPDM-E BRANCH LINE CIRCUIT

< DTC/CIRCUIT DIAGNOSIS >

[CAN SYSTEM (TYPE 9)]

IPDM-E BRANCH LINE CIRCUIT

Diagnosis Procedure

INFOID:000000008970700

1. CHECK CONNECTOR

1. Turn the ignition switch OFF.
2. Disconnect the battery cable from the negative terminal.
3. Check the terminals and connectors of the IPDM E/R for damage, bend and loose connection (unit side and connector side).

Is the inspection result normal?

- YES >> GO TO 2.
NO >> Repair the terminal and connector.

2. CHECK HARNESS FOR OPEN CIRCUIT

1. Disconnect the connector of IPDM E/R.
2. Check the resistance between the IPDM E/R harness connector terminals.

IPDM E/R harness connector			Resistance (Ω)
Connector No.	Terminal No.		
E119	29	28	Approx. 54 – 66

Is the measurement value within the specification?

- YES >> GO TO 3.
NO >> Repair the IPDM E/R branch line.

3. CHECK POWER SUPPLY AND GROUND CIRCUIT

Check the power supply and the ground circuit of the IPDM E/R. Refer to [PCS-31, "Diagnosis Procedure"](#).

Is the inspection result normal?

- YES (Present error)>>Replace the IPDM E/R. Refer to [PCS-32, "Removal and Installation"](#).
YES (Past error)>>Error was detected in the IPDM E/R branch line.
NO >> Repair the power supply and the ground circuit.

TCM BRANCH LINE CIRCUIT

< DTC/CIRCUIT DIAGNOSIS >

[CAN SYSTEM (TYPE 9)]

TCM BRANCH LINE CIRCUIT

Diagnosis Procedure

INFOID:000000008970701

1. CHECK CONNECTOR

1. Turn the ignition switch OFF.
2. Disconnect the battery cable from the negative terminal.
3. Check the following terminals and connectors for damage, bend and loose connection (unit side and connector side).
 - TCM
 - Harness connector F32
 - Harness connector E2

Is the inspection result normal?

- YES >> GO TO 2.
NO >> Repair the terminal and connector.

2. CHECK HARNESS FOR OPEN CIRCUIT

1. Disconnect the connector of TCM.
2. Check the resistance between the TCM harness connector terminals.

TCM harness connector		Resistance (Ω)
Connector No.	Terminal No.	
F15	33 23	Approx. 54 – 66

Is the measurement value within the specification?

- YES >> GO TO 3.
NO >> Repair the TCM branch line.

3. CHECK POWER SUPPLY AND GROUND CIRCUIT

Check the power supply and the ground circuit of the TCM. Refer to [TM-165, "Diagnosis Procedure"](#).

Is the inspection result normal?

- YES (Present error)>>Replace the TCM. Refer to [TM-197, "Removal and Installation"](#).
YES (Past error)>>Error was detected in the TCM branch line.
NO >> Repair the power supply and the ground circuit.

A
B
C
D
E
F
G
H
I
J
K
L

LAN

ABS BRANCH LINE CIRCUIT

< DTC/CIRCUIT DIAGNOSIS >

[CAN SYSTEM (TYPE 9)]

ABS BRANCH LINE CIRCUIT

Diagnosis Procedure

INFOID:000000008970702

1. CHECK CONNECTOR

1. Turn the ignition switch OFF.
2. Disconnect the battery cable from the negative terminal.
3. Check the terminals and connectors of the ABS actuator and electric unit (control unit) for damage, bend and loose connection (unit side and connector side).

Is the inspection result normal?

- YES >> GO TO 2.
NO >> Repair the terminal and connector.

2. CHECK HARNESS FOR OPEN CIRCUIT

1. Disconnect the connector of ABS actuator and electric unit (control unit).
2. Check the resistance between the ABS actuator and electric unit (control unit) harness connector terminals.

ABS actuator and electric unit (control unit) harness connector			Resistance (Ω)
Connector No.	Terminal No.		
E125	25	15	Approx. 54 – 66

Is the measurement value within the specification?

- YES >> GO TO 3.
NO >> Repair the ABS actuator and electric unit (control unit) branch line.

3. CHECK POWER SUPPLY AND GROUND CIRCUIT

Check the power supply and the ground circuit of the ABS actuator and electric unit (control unit). Refer to [BRC-63. "Diagnosis Procedure"](#).

Is the inspection result normal?

- YES (Present error)>>Replace the ABS actuator and electric unit (control unit). Refer to [BRC-121. "Removal and Installation"](#).
YES (Past error)>>Error was detected in the ABS actuator and electric unit (control unit) branch line.
NO >> Repair the power supply and the ground circuit.

EPS BRANCH LINE CIRCUIT

< DTC/CIRCUIT DIAGNOSIS >

[CAN SYSTEM (TYPE 9)]

EPS BRANCH LINE CIRCUIT

Diagnosis Procedure

INFOID:000000008970703

1. CHECK CONNECTOR

1. Turn the ignition switch OFF.
2. Disconnect the battery cable from the negative terminal.
3. Check the terminals and connectors of the power steering control module for damage, bend and loose connection (unit side and connector side).

Is the inspection result normal?

- YES >> GO TO 2.
NO >> Repair the terminal and connector.

2. CHECK HARNESS FOR OPEN CIRCUIT

1. Disconnect the connector of power steering control module.
2. Check the resistance between the power steering control module harness connector terminals.

Power steering control module harness connector			Resistance (Ω)
Connector No.	Terminal No.		
E62	8	7	Approx. 54 – 66

Is the measurement value within the specification?

- YES >> GO TO 3.
NO >> Repair the power steering control module branch line.

3. CHECK POWER SUPPLY AND GROUND CIRCUIT

Check the power supply and the ground circuit of the power steering control module. Refer to [STC-22, "Diagnosis Procedure"](#).

Is the inspection result normal?

- YES (Present error)>>Replace the power steering oil pump assembly. Refer to [ST-51, "Removal and Installation"](#).
YES (Past error)>>Error was detected in the power steering control module branch line.
NO >> Repair the power supply and the ground circuit.

A
B
C
D
E
F
G
H
I
J
K
L

LAN

A-BAG BRANCH LINE CIRCUIT

< DTC/CIRCUIT DIAGNOSIS >

[CAN SYSTEM (TYPE 9)]

A-BAG BRANCH LINE CIRCUIT

Diagnosis Procedure

INFOID:000000008970704

WARNING:

- Before servicing, turn ignition switch OFF, disconnect battery negative terminal, and wait 3 minutes or more. (To discharge backup capacitor.)
- Never use unspecified tester or other measuring device.

1.CHECK CONNECTOR

1. Turn the ignition switch OFF.
2. Disconnect the battery cable from the negative terminal.
3. Check the terminals and connectors of the air bag diagnosis sensor unit for damage, bend and loose connection (unit side and connector side).

Is the inspection result normal?

YES >> GO TO 2.

NO >> Replace the main harness.

2.CHECK AIR BAG DIAGNOSIS SENSOR UNIT

Check the air bag diagnosis sensor unit. Refer to [SRC-40, "Work Flow"](#).

Is the inspection result normal?

YES >> Replace the main harness.

NO >> Replace parts whose air bag system has a malfunction.

AV BRANCH LINE CIRCUIT

< DTC/CIRCUIT DIAGNOSIS >

[CAN SYSTEM (TYPE 9)]

AV BRANCH LINE CIRCUIT

Diagnosis Procedure

INFOID:000000008970705

1. CHECK CONNECTOR

1. Turn the ignition switch OFF.
2. Disconnect the battery cable from the negative terminal.
3. Check the terminals and connectors of the AV control unit for damage, bend and loose connection (unit side and connector side).

Is the inspection result normal?

- YES >> GO TO 2.
NO >> Repair the terminal and connector.

2. CHECK HARNESS FOR OPEN CIRCUIT

1. Disconnect the connector of AV control unit.
 2. Check the resistance between the AV control unit harness connector terminals.
- With BOSE audio without navigation

AV control unit harness connector			Resistance (Ω)
Connector No.	Terminal No.		
M42	11	12	Approx. 54 – 66

- Without BOSE audio with navigation

AV control unit harness connector			Resistance (Ω)
Connector No.	Terminal No.		
M124	11	12	Approx. 54 – 66

- With BOSE audio with navigation

AV control unit harness connector			Resistance (Ω)
Connector No.	Terminal No.		
M163	78	62	Approx. 54 – 66

Is the measurement value within the specification?

- YES >> GO TO 3.
NO >> Repair the AV control unit branch line.

3. CHECK POWER SUPPLY AND GROUND CIRCUIT

Check the power supply and the ground circuit of the AV control unit. Refer to the following.

- Mid audio without BOSE: [AV-143, "AV CONTROL UNIT : Diagnosis Procedure"](#)
- Mid audio with BOSE: [AV-303, "AV CONTROL UNIT : Diagnosis Procedure"](#)
- Premium audio with navigation: [AV-532, "AV CONTROL UNIT : Diagnosis Procedure"](#)

Is the inspection result normal?

- YES (Present error)>>Replace the AV control unit. Refer to the following.
- Mid audio without BOSE: [AV-186, "Removal and Installation"](#)
 - Mid audio with BOSE: [AV-357, "Removal and Installation"](#)
 - Premium audio with navigation: [AV-585, "Removal and Installation"](#)

YES (Past error)>>Error was detected in the AV control unit branch line.

- NO >> Repair the power supply and the ground circuit.

A
B
C
D
E
F
G
H
I
J
K
L
N
O
P

LAN

DLC BRANCH LINE CIRCUIT (CAN COMMUNICATION CIRCUIT 1)

< DTC/CIRCUIT DIAGNOSIS >

[CAN SYSTEM (TYPE 9)]

DLC BRANCH LINE CIRCUIT (CAN COMMUNICATION CIRCUIT 1)

Diagnosis Procedure

INFOID:000000008970707

1. CHECK CONNECTOR

1. Turn the ignition switch OFF.
2. Disconnect the battery cable from the negative terminal.
3. Check the terminals and connectors of the data link connector for damage, bend and loose connection (connector side and harness side).

Is the inspection result normal?

YES >> GO TO 2.

NO >> Repair the terminal and connector.

2. CHECK HARNESS FOR OPEN CIRCUIT

Check the resistance between the data link connector terminals.

Data link connector			Resistance (Ω)
Connector No.	Terminal No.		
M22	6	14	Approx. 54 – 66

Is the measurement value within the specification?

YES (Present error)>>Check CAN system type decision again.

YES (Past error)>>Error was detected in the data link connector branch line circuit (CAN communication circuit 1 side).

NO >> Repair the data link connector branch line (CAN communication circuit 1 side).

DLC BRANCH LINE CIRCUIT (CAN COMMUNICATION CIRCUIT 2)

< DTC/CIRCUIT DIAGNOSIS >

[CAN SYSTEM (TYPE 9)]

DLC BRANCH LINE CIRCUIT (CAN COMMUNICATION CIRCUIT 2)

Diagnosis Procedure

INFOID:000000008970708

1. CHECK CONNECTOR

1. Turn the ignition switch OFF.
2. Disconnect the battery cable from the negative terminal.
3. Check the terminals and connectors of the data link connector for damage, bend and loose connection (connector side and harness side).

Is the inspection result normal?

- YES >> GO TO 2.
NO >> Repair the terminal and connector.

2. CHECK HARNESS FOR OPEN CIRCUIT

Check the resistance between the data link connector terminals.

Data link connector			Resistance (Ω)
Connector No.	Terminal No.		
M22	13	12	Approx. 54 – 66

Is the measurement value within the specification?

- YES (Present error)>>Check CAN system type decision again.
YES (Past error)>>Error was detected in the data link connector branch line circuit (CAN communication circuit 2 side).
NO >> Repair the data link connector branch line (CAN communication circuit 2 side).

A
B
C
D
E
F
G
H
I
J
K
L
N
O
P

LAN

HVAC BRANCH LINE CIRCUIT

< DTC/CIRCUIT DIAGNOSIS >

[CAN SYSTEM (TYPE 9)]

HVAC BRANCH LINE CIRCUIT

Diagnosis Procedure

INFOID:000000008970709

1. CHECK CONNECTOR

1. Turn the ignition switch OFF.
2. Disconnect the battery cable from the negative terminal.
3. Check the terminals and connectors of the A/C auto amp. for damage, bend and loose connection (unit side and connector side).

Is the inspection result normal?

- YES >> GO TO 2.
NO >> Repair the terminal and connector.

2. CHECK HARNESS FOR OPEN CIRCUIT

1. Disconnect the connector of A/C auto amp.
2. Check the resistance between the A/C auto amp. harness connector terminals.

A/C auto amp. harness connector			Resistance (Ω)
Connector No.	Terminal No.		
M50	1	21	Approx. 54 – 66

Is the measurement value within the specification?

- YES >> GO TO 3.
NO >> Repair the A/C auto amp. branch line.

3. CHECK POWER SUPPLY AND GROUND CIRCUIT

Check the power supply and the ground circuit of the A/C auto amp. Refer to [HAC-113, "A/C AUTO AMP. : Diagnosis Procedure"](#).

Is the inspection result normal?

- YES (Present error)>>Replace the A/C auto amp. Refer to [HAC-156, "Removal and Installation"](#).
YES (Past error)>>Error was detected in the A/C auto amp. branch line.
NO >> Repair the power supply and the ground circuit.

M&A BRANCH LINE CIRCUIT

Diagnosis Procedure

INFOID:000000008970710

1.CHECK CONNECTOR

1. Turn the ignition switch OFF.
2. Disconnect the battery cable from the negative terminal.
3. Check the terminals and connectors of the combination meter for damage, bend and loose connection (unit side and connector side).

Is the inspection result normal?

- YES >> GO TO 2.
- NO >> Repair the terminal and connector.

2.CHECK HARNESS FOR OPEN CIRCUIT

1. Disconnect the connector of combination meter.
2. Check the resistance between the combination meter harness connector terminals.

Combination meter harness connector			Resistance (Ω)
Connector No.	Terminal No.		
M24	39	38	Approx. 54 – 66

Is the measurement value within the specification?

- YES >> GO TO 3.
- NO >> Repair the combination meter branch line.

3.CHECK POWER SUPPLY AND GROUND CIRCUIT

Check the power supply and the ground circuit of the combination meter. Refer to [MWI-59, "COMBINATION METER : Diagnosis Procedure"](#).

Is the inspection result normal?

- YES (Present error)>>Replace the combination meter. Refer to [MWI-82, "Removal and Installation"](#).
- YES (Past error)>>Error was detected in the combination meter branch line.
- NO >> Repair the power supply and the ground circuit.

LAN

SONAR BRANCH LINE CIRCUIT

< DTC/CIRCUIT DIAGNOSIS >

[CAN SYSTEM (TYPE 9)]

SONAR BRANCH LINE CIRCUIT

Diagnosis Procedure

INFOID:000000008970711

1. CHECK CONNECTOR

1. Turn the ignition switch OFF.
2. Disconnect the battery cable from the negative terminal.
3. Check the terminals and connectors of sonar control unit for damage, bend and loose connection (unit side and connector side).

Is the inspection result normal?

- YES >> GO TO 2.
NO >> Repair the terminal and connector.

2. CHECK HARNESS FOR OPEN CIRCUIT

1. Disconnect the connector of sonar control unit.
2. Check the resistance between the sonar control unit harness connector terminals.

Sonar control unit harness connector			Resistance (Ω)
Connector No.	Terminal No.		
M70	5	6	Approx. 54 – 66

Is the measurement value within the specification?

- YES >> GO TO 3.
NO >> Replace the main harness.

3. CHECK POWER SUPPLY AND GROUND CIRCUIT

Check the power supply and the ground circuit of the sonar control unit. Refer to [SN-32, "Diagnosis Procedure"](#).

Is the inspection result normal?

- YES (Present error)>>Replace the sonar control unit. Refer to [SN-34, "Removal and Installation"](#).
YES (Past error)>>Error was detected in the sonar control unit branch line.
NO >> Repair the power supply and the ground circuit.

STRG BRANCH LINE CIRCUIT

< DTC/CIRCUIT DIAGNOSIS >

[CAN SYSTEM (TYPE 9)]

STRG BRANCH LINE CIRCUIT

Diagnosis Procedure

INFOID:000000008970712

1. CHECK CONNECTOR

1. Turn the ignition switch OFF.
2. Disconnect the battery cable from the negative terminal.
3. Check the terminals and connectors of the steering angle sensor for damage, bend and loose connection (unit side and connector side).

Is the inspection result normal?

- YES >> GO TO 2.
NO >> Repair the terminal and connector.

2. CHECK HARNESS FOR OPEN CIRCUIT

1. Disconnect the connector of steering angle sensor.
2. Check the resistance between the steering angle sensor harness connector terminals.

Steering angle sensor harness connector			Resistance (Ω)
Connector No.	Terminal No.		
M54	5	2	Approx. 54 – 66

Is the measurement value within the specification?

- YES >> GO TO 3.
NO >> Repair the steering angle sensor branch line.

3. CHECK POWER SUPPLY AND GROUND CIRCUIT

Check the power supply and the ground circuit of the steering angle sensor. Refer to [BRC-44, "Wiring Diagram"](#).

Is the inspection result normal?

- YES (Present error)>>Replace the steering angle sensor. Refer to [BRC-124, "Removal and Installation"](#).
YES (Past error)>>Error was detected in the steering angle sensor branch line.
NO >> Repair the power supply and the ground circuit.

A
B
C
D
E
F
G
H
I
J
K
L

LAN

N
O
P

ADP BRANCH LINE CIRCUIT

< DTC/CIRCUIT DIAGNOSIS >

[CAN SYSTEM (TYPE 9)]

ADP BRANCH LINE CIRCUIT

Diagnosis Procedure

INFOID:000000008970713

1. CHECK CONNECTOR

1. Turn the ignition switch OFF.
2. Disconnect the battery cable from the negative terminal.
3. Check the following terminals and connectors for damage, bend and loose connection (unit side and connector side).
 - Driver seat control unit
 - Harness connector B200
 - Harness connector B54
 - CAN gateway (Models with around view monitor)

Is the inspection result normal?

- YES-1 >> Models with around view monitor: GO TO 2.
YES-2 >> Models without around view monitor: GO TO 3.
NO >> Repair the terminal and connector.

2. CHECK HARNESS CONTINUITY (OPEN CIRCUIT)

1. Disconnect the connector of CAN gateway.
2. Check the continuity between the CAN gateway harness connector terminals.

CAN gateway harness connector			Continuity
Connector No.	Terminal No.		
M5	4	6	Existed
	10	12	Existed

Is the inspection result normal?

- YES >> GO TO 3.
NO >> Check the harness and repair the root cause (CAN communication circuit 2 side).

3. CHECK HARNESS FOR OPEN CIRCUIT

1. Connect the connector of CAN gateway. (Models with around view monitor)
2. Disconnect the connector of driver seat control unit.
3. Check the resistance between the driver seat control unit harness connector terminals.

Driver seat control unit harness connector			Resistance (Ω)
Connector No.	Terminal No.		
B209	16	32	Approx. 54 – 66

Is the measurement value within the specification?

- YES >> GO TO 4.
NO >> Repair the driver seat control unit branch line.

4. CHECK POWER SUPPLY AND GROUND CIRCUIT

Check the power supply and the ground circuit of the driver seat control unit. Refer to [ADP-83, "DRIVER SEAT CONTROL UNIT : Diagnosis Procedure"](#).

Is the inspection result normal?

- YES (Present error)>>Replace the driver seat control unit. Refer to [ADP-156, "Removal and Installation"](#).
YES (Past error)>>Error was detected in the driver seat control unit branch line.
NO >> Repair the power supply and the ground circuit.

4WD BRANCH LINE CIRCUIT

< DTC/CIRCUIT DIAGNOSIS >

[CAN SYSTEM (TYPE 9)]

4WD BRANCH LINE CIRCUIT

Diagnosis Procedure

INFOID:000000008970714

1. CHECK CONNECTOR

1. Turn the ignition switch OFF.
2. Disconnect the battery cable from the negative terminal.
3. Check the following terminals and connectors for damage, bend and loose connection (unit side and connector side).
 - 4WD control unit
 - CAN gateway (Models with around view monitor)

Is the inspection result normal?

- YES-1 >> Models with around view monitor: GO TO 2.
YES-2 >> Models without around view monitor: GO TO 3.
NO >> Repair the terminal and connector.

2. CHECK HARNESS CONTINUITY (OPEN CIRCUIT)

1. Disconnect the connector of CAN gateway.
2. Check the continuity between the CAN gateway harness connector terminals.

CAN gateway harness connector		Continuity	
Connector No.	Terminal No.		
M5	4	6	Existed
	10	12	Existed

Is the inspection result normal?

- YES >> GO TO 3.
NO >> Check the harness and repair the root cause (CAN communication circuit 2 side).

3. CHECK HARNESS FOR OPEN CIRCUIT

1. Connect the connector of CAN gateway. (Models with around view monitor)
2. Disconnect the connector of 4WD control unit.
3. Check the resistance between the 4WD control unit harness connector terminals.

4WD control unit harness connector		Resistance (Ω)	
Connector No.	Terminal No.		
B67	8	16	Approx. 54 – 66

Is the measurement value within the specification?

- YES >> GO TO 4.
NO >> Repair the 4WD control unit branch line.

4. CHECK POWER SUPPLY AND GROUND CIRCUIT

Check the power supply and the ground circuit of the 4WD control unit. Refer to [DLN-59, "Diagnosis Procedure"](#).

Is the inspection result normal?

- YES (Present error)>>Replace the 4WD control unit. Refer to [DLN-71, "Removal and Installation"](#).
YES (Past error)>>Error was detected in the 4WD control unit branch line.
NO >> Repair the power supply and the ground circuit.

A
B
C
D
E
F
G
H
I
J
K
L
LAN
N
O
P

PWBD BRANCH LINE CIRCUIT

< DTC/CIRCUIT DIAGNOSIS >

[CAN SYSTEM (TYPE 9)]

PWBD BRANCH LINE CIRCUIT

Diagnosis Procedure

INFOID:000000008970715

1. CHECK CONNECTOR

1. Turn the ignition switch OFF.
2. Disconnect the battery cable from the negative terminal.
3. Check the following terminals and connectors for damage, bend and loose connection (unit side and connector side).
 - Automatic back door control module
 - CAN gateway (Models with around view monitor)

Is the inspection result normal?

- YES-1 >> Models with around view monitor: GO TO 2.
YES-2 >> Models without around view monitor: GO TO 3.
NO >> Repair the terminal and connector.

2. CHECK HARNESS CONTINUITY (OPEN CIRCUIT)

1. Disconnect the connector of CAN gateway.
2. Check the continuity between the CAN gateway harness connector terminals.

CAN gateway harness connector		Continuity	
Connector No.	Terminal No.		
M5	4	6	Existed
	10	12	Existed

Is the inspection result normal?

- YES >> GO TO 3.
NO >> Check the harness and repair the root cause (CAN communication circuit 2 side).

3. CHECK HARNESS FOR OPEN CIRCUIT

1. Connect the connector of CAN gateway. (Models with around view monitor)
2. Disconnect the connector of automatic back door control module.
3. Check the resistance between the automatic back door control module harness connector terminals.

Automatic back door control module harness connector		Resistance (Ω)	
Connector No.	Terminal No.		
B55	24	12	Approx. 54 – 66

Is the measurement value within the specification?

- YES >> GO TO 4.
NO >> Replace the body harness.

4. CHECK POWER SUPPLY AND GROUND CIRCUIT

Check the power supply and the ground circuit of the automatic back door control module. Refer to [DLK-160, "AUTOMATIC BACK DOOR CONTROL UNIT : Diagnosis Procedure"](#).

Is the inspection result normal?

- YES (Present error)>>Replace the automatic back door control module. Refer to [DLK-317, "Removal and Installation"](#).
YES (Past error)>>Error was detected in the automatic back door control module branch line.
NO >> Repair the power supply and the ground circuit.

BCM BRANCH LINE CIRCUIT

< DTC/CIRCUIT DIAGNOSIS >

[CAN SYSTEM (TYPE 9)]

BCM BRANCH LINE CIRCUIT

Diagnosis Procedure

INFOID:000000008970716

1. CHECK CONNECTOR

1. Turn the ignition switch OFF.
2. Disconnect the battery cable from the negative terminal.
3. Check the following terminals and connectors for damage, bend and loose connection (unit side and connector side).
 - BCM
 - Harness connector M84 (Models without around view monitor)
 - Harness connector B101 (Models without around view monitor)
 - Harness connector B124 (Models without around view monitor)
 - Harness connector B32 (Models without around view monitor)
 - Harness connector B69 (2WD models without automatic back door system)
 - Harness connector M40 (2WD models without automatic back door system)

Is the inspection result normal?

YES >> GO TO 2.

NO >> Repair the terminal and connector.

2. CHECK HARNESS FOR OPEN CIRCUIT

1. Disconnect the connector of BCM.
2. Check the resistance between the BCM harness connector terminals.

BCM harness connector			Resistance (Ω)
Connector No.	Terminal No.		
M19	60	59	Approx. 108 – 132

Is the measurement value within the specification?

YES >> GO TO 3.

NO >> Repair the BCM branch line.

3. CHECK POWER SUPPLY AND GROUND CIRCUIT

Check the power supply and the ground circuit of the BCM. Refer to [BCS-72, "Diagnosis Procedure"](#).

Is the inspection result normal?

YES (Present error)>>Replace the BCM. Refer to [BCS-78, "Removal and Installation"](#).

YES (Past error)>>Error was detected in the BCM branch line.

NO >> Repair the power supply and the ground circuit.

A
B
C
D
E
F
G
H
I
J
K
L

LAN

CGW BRANCH LINE CIRCUIT (CAN COMMUNICATION CIRCUIT 1)

< DTC/CIRCUIT DIAGNOSIS >

[CAN SYSTEM (TYPE 9)]

CGW BRANCH LINE CIRCUIT (CAN COMMUNICATION CIRCUIT 1)

Diagnosis Procedure

INFOID:000000008970717

1. CHECK DTC

Check DTC of the CAN gateway with CONSULT.

Is U1010 or B2600 indicated?

- YES >> Perform a diagnosis of the indicated DTC.
- NO >> GO TO 2.

2. CHECK CONNECTOR

1. Turn the ignition switch OFF.
2. Disconnect the battery cable from the negative terminal.
3. Check the terminals and connectors of the CAN gateway for damage, bend and loose connection (unit side and connector side).

Is the inspection result normal?

- YES >> GO TO 3.
- NO >> Repair the terminal and connector.

3. CHECK HARNESS FOR OPEN CIRCUIT

1. Disconnect the connector of CAN gateway.
2. Check the resistance between the CAN gateway harness connector terminals.

CAN gateway harness connector			Resistance (Ω)
Connector No.	Terminal No.		
M5	1	7	Approx. 54 – 66

Is the measurement value within the specification?

- YES >> GO TO 4.
- NO >> Repair the CAN gateway branch line (CAN communication circuit 1 side).

4. CHECK POWER SUPPLY AND GROUND CIRCUIT

Check the power supply and the ground circuit of the CAN gateway. Refer to [LAN-107. "Diagnosis Procedure"](#).

Is the inspection result normal?

- YES (Present error)>>Replace the CAN gateway. Refer to [LAN-108. "Removal and Installation"](#).
- YES (Past error)>>Error was detected in the CAN gateway branch line (CAN communication circuit 1 side).
- NO >> Repair the power supply and the ground circuit.

CGW BRANCH LINE CIRCUIT (CAN COMMUNICATION CIRCUIT 2)

< DTC/CIRCUIT DIAGNOSIS >

[CAN SYSTEM (TYPE 9)]

CGW BRANCH LINE CIRCUIT (CAN COMMUNICATION CIRCUIT 2)

Diagnosis Procedure

INFOID:000000008970718

1. CHECK DTC

Check DTC of the CAN gateway with CONSULT.

Is U1010 or B2600 indicated?

- YES >> Perform a diagnosis of the indicated DTC.
- NO >> GO TO 2.

2. CHECK CONNECTOR

1. Turn the ignition switch OFF.
2. Disconnect the battery cable from the negative terminal.
3. Check the following terminals and connectors of the CAN gateway for damage, bend and loose connection (unit side and connector side).

Is the inspection result normal?

- YES >> GO TO 3.
- NO >> Repair the terminal and connector.

3. CHECK HARNESS CONTINUITY (OPEN CIRCUIT)

1. Disconnect the connector of CAN gateway.
2. Check the continuity between the CAN gateway harness connector terminals.

CAN gateway harness connector			Continuity
Connector No.	Terminal No.		
M5	4	6	Existed
	10	12	Existed

Is the inspection result normal?

- YES >> GO TO 4.
- NO >> Repair the CAN gateway branch line (CAN communication circuit 2 side).

4. CHECK POWER SUPPLY AND GROUND CIRCUIT

Check the power supply and the ground circuit of the CAN gateway. Refer to [LAN-107, "Diagnosis Procedure"](#).

Is the inspection result normal?

- YES (Present error)>>Replace the CAN gateway. Refer to [LAN-108, "Removal and Installation"](#).
- YES (Past error)>>Error was detected in the CAN gateway branch line (CAN communication circuit 2 side).
- NO >> Repair the power supply and the ground circuit.

A
B
C
D
E
F
G
H
I
J
K
L
N
O
P

LAN

AVM BRANCH LINE CIRCUIT

< DTC/CIRCUIT DIAGNOSIS >

[CAN SYSTEM (TYPE 9)]

AVM BRANCH LINE CIRCUIT

Diagnosis Procedure

INFOID:000000008970719

1. CHECK CONNECTOR

1. Turn the ignition switch OFF.
2. Disconnect the battery cable from the negative terminal.
3. Check the following terminals and connectors for damage, bend and loose connection (unit side and connector side).
 - Around view monitor control unit
 - CAN gateway

Is the inspection result normal?

YES >> GO TO 2.

NO >> Repair the terminal and connector.

2. CHECK HARNESS CONTINUITY (OPEN CIRCUIT)

1. Disconnect the connector of CAN gateway.
2. Check the continuity between the CAN gateway harness connector terminals.

CAN gateway harness connector			Continuity
Connector No.	Terminal No.		
M5	4	6	Existed
	10	12	Existed

Is the inspection result normal?

YES >> GO TO 3.

NO >> Check the harness and repair the root cause (CAN communication circuit 2 side).

3. CHECK HARNESS FOR OPEN CIRCUIT

1. Connect the connector of CAN gateway.
2. Disconnect the connector of around view monitor control unit.
3. Check the resistance between the around view monitor control unit harness connector terminals.

Around view monitor control unit harness connector			Resistance (Ω)
Connector No.	Terminal No.		
M96	12	10	Approx. 54 – 66

Is the measurement value within the specification?

YES >> GO TO 4.

NO >> Replace the main harness.

4. CHECK POWER SUPPLY AND GROUND CIRCUIT

Check the power supply and the ground circuit of the around view monitor control unit. Refer to [AV-537, "AROUND VIEW MONITOR CONTROL UNIT : Diagnosis Procedure"](#).

Is the inspection result normal?

YES (Present error)>>Replace the around view monitor control unit. Refer to [AV-603, "Removal and Installation"](#).

YES (Past error)>>Error was detected in the around view monitor control unit branch line.

NO >> Repair the power supply and the ground circuit.

CAN COMMUNICATION CIRCUIT 1

< DTC/CIRCUIT DIAGNOSIS >

[CAN SYSTEM (TYPE 9)]

CAN COMMUNICATION CIRCUIT 1

Diagnosis Procedure

INFOID:000000008970721

1. CONNECTOR INSPECTION

1. Turn the ignition switch OFF.
2. Disconnect the battery cable from the negative terminal.
3. Disconnect all the unit connectors on CAN communication circuit 1.
4. Check terminals and connectors for damage, bend and loose connection.

Is the inspection result normal?

- YES >> GO TO 2.
NO >> Repair the terminal and connector.

2. CHECK HARNESS CONTINUITY (SHORT CIRCUIT)

Check the continuity between the data link connector terminals.

Data link connector		Continuity
Connector No.	Terminal No.	
M22	6 14	Not existed

Is the inspection result normal?

- YES >> GO TO 3.
NO >> Check the harness and repair the root cause.

3. CHECK HARNESS CONTINUITY (SHORT CIRCUIT)

Check the continuity between the data link connector and the ground.

Data link connector		Ground	Continuity
Connector No.	Terminal No.		
M22	6		Not existed
	14		Not existed

Is the inspection result normal?

- YES >> GO TO 4.
NO >> Check the harness and repair the root cause.

4. CHECK ECM AND BCM TERMINATION CIRCUIT

1. Remove the ECM and the BCM.
2. Check the resistance between the ECM terminals.

ECM		Resistance (Ω)
Terminal No.		
114	113	Approx. 108 – 132

3. Check the resistance between the BCM terminals.

BCM		Resistance (Ω)
Terminal No.		
60	59	Approx. 108 – 132

Is the measurement value within the specification?

- YES >> GO TO 5.
NO >> Replace the ECM and/or the BCM.

5. CHECK SYMPTOM

Connect all the connectors. Check if the symptoms described in the "Symptom (Results from interview with customer)" are reproduced.

A
B
C
D
E
F
G
H
I
J
K
L

LAN

N
O
P

CAN COMMUNICATION CIRCUIT 1

< DTC/CIRCUIT DIAGNOSIS >

[CAN SYSTEM (TYPE 9)]

Inspection result

Reproduced>>GO TO 6.

Non-reproduced>>Start the diagnosis again. Follow the trouble diagnosis procedure when past error is detected.

6.CHECK UNIT REPRODUCTION

Perform the reproduction test as per the following procedure for each unit.

1. Turn the ignition switch OFF.
2. Disconnect the battery cable from the negative terminal.
3. Disconnect one of the unit connectors of CAN communication circuit 1.

NOTE:

ECM and BCM have a termination circuit. Check other units first.

4. Connect the battery cable to the negative terminal. Check if the symptoms described in the “Symptom (Results from interview with customer)” are reproduced.

NOTE:

Although unit-related error symptoms occur, do not confuse them with other symptoms.

Inspection result

Reproduced>>Connect the connector. Check other units as per the above procedure.

Non-reproduced>>Replace the unit whose connector was disconnected.

CAN COMMUNICATION CIRCUIT 2

< DTC/CIRCUIT DIAGNOSIS >

[CAN SYSTEM (TYPE 9)]

CAN COMMUNICATION CIRCUIT 2

Diagnosis Procedure

INFOID:000000008970722

1. CONNECTOR INSPECTION

1. Turn the ignition switch OFF.
2. Disconnect the battery cable from the negative terminal.
3. Disconnect all the unit connectors on CAN communication circuit 2.
4. Check terminals and connectors for damage, bend and loose connection.

Is the inspection result normal?

- YES >> GO TO 2.
NO >> Repair the terminal and connector.

2. CHECK HARNESS CONTINUITY (SHORT CIRCUIT)

Check the continuity between the data link connector terminals.

Data link connector		Continuity
Connector No.	Terminal No.	
M22	13	Not existed
	12	

Is the inspection result normal?

- YES >> GO TO 3.
NO >> Check the harness and repair the root cause.

3. CHECK HARNESS CONTINUITY (SHORT CIRCUIT)

Check the continuity between the data link connector and the ground.

Data link connector		Ground	Continuity
Connector No.	Terminal No.		
M22	13		Not existed
	12		Not existed

Is the inspection result normal?

- YES >> GO TO 4.
NO >> Check the harness and repair the root cause.

4. CHECK CAN GATEWAY TERMINATION CIRCUIT

1. Remove the CAN gateway.
2. Check the resistance between the CAN gateway terminals.

CAN gateway		Resistance (Ω)
Terminal No.		
4	10	Approx. 108 – 132
6	12	Approx. 108 – 132

Is the measurement value within the specification?

- YES >> GO TO 5.
NO >> Replace the CAN gateway.

5. CHECK SYMPTOM

Connect all the connectors. Check if the symptoms described in the "Symptom (Results from interview with customer)" are reproduced.

Inspection result

- Reproduced >> GO TO 6.
Non-reproduced >> Start the diagnosis again. Follow the trouble diagnosis procedure when past error is detected.

A
B
C
D
E
F
G
H
I
J
K
L

LAN

N
O
P

CAN COMMUNICATION CIRCUIT 2

< DTC/CIRCUIT DIAGNOSIS >

[CAN SYSTEM (TYPE 9)]

6. CHECK UNIT REPRODUCTION

Perform the reproduction test as per the following procedure for each unit.

1. Turn the ignition switch OFF.
2. Disconnect the battery cable from the negative terminal.
3. Disconnect one of the unit connectors of CAN communication circuit 2.

NOTE:

CAN gateway has two termination circuits. Check other units first.

4. Connect the battery cable to the negative terminal. Check if the symptoms described in the “Symptom (Results from interview with customer)” are reproduced.

NOTE:

Although unit-related error symptoms occur, do not confuse them with other symptoms.

Inspection result

Reproduced>>Connect the connector. Check other units as per the above procedure.

Non-reproduced>>Replace the unit whose connector was disconnected.