

A  
B  
C

# EXL

## SECTION EXL

### EXTERIOR LIGHTING SYSTEM

D  
E

## CONTENTS

<p><b>PRECAUTION</b> ..... 4</p> <p><b>PRECAUTIONS</b> ..... 4</p> <p style="padding-left: 20px;">Precaution for Supplemental Restraint System (SRS) "AIR BAG" and "SEAT BELT PRE-TENSIONER" .....4</p> <p style="padding-left: 20px;">Precaution for Work .....4</p> <p><b>PREPARATION</b> ..... 5</p> <p><b>PREPARATION</b> ..... 5</p> <p style="padding-left: 20px;">Special Service Tool .....5</p> <p><b>SYSTEM DESCRIPTION</b> ..... 6</p> <p><b>COMPONENT PARTS</b> ..... 6</p> <p style="padding-left: 20px;">Component Parts Location .....6</p> <p style="padding-left: 20px;">Component Description .....7</p> <p><b>SYSTEM</b> ..... 8</p> <p><b>HEADLAMP SYSTEM</b> .....8</p> <p style="padding-left: 20px;">HEADLAMP SYSTEM : System Diagram .....8</p> <p style="padding-left: 20px;">HEADLAMP SYSTEM : System Description .....8</p> <p><b>AUTO LIGHT SYSTEM</b> .....8</p> <p style="padding-left: 20px;">AUTO LIGHT SYSTEM : System Diagram .....9</p> <p style="padding-left: 20px;">AUTO LIGHT SYSTEM : System Description .....9</p> <p><b>DAYTIME RUNNING LIGHT SYSTEM</b> .....9</p> <p style="padding-left: 20px;">DAYTIME RUNNING LIGHT SYSTEM : System Diagram .....9</p> <p style="padding-left: 20px;">DAYTIME RUNNING LIGHT SYSTEM : System Description ..... 10</p> <p><b>TURN SIGNAL AND HAZARD WARNING LAMP SYSTEM</b> ..... 10</p> <p style="padding-left: 20px;">TURN SIGNAL AND HAZARD WARNING LAMP SYSTEM : System Diagram ..... 10</p> <p style="padding-left: 20px;">TURN SIGNAL AND HAZARD WARNING LAMP SYSTEM : System Description ..... 10</p>	<p style="text-align: right;">F G H I J K L M N O P</p> <p><b>PARKING, LICENSE PLATE, SIDE MARKER AND TAIL LAMP SYSTEM</b> .....10</p> <p style="padding-left: 20px;">PARKING, LICENSE PLATE, SIDE MARKER AND TAIL LAMP SYSTEM : System Diagram .....10</p> <p style="padding-left: 20px;">PARKING, LICENSE PLATE, SIDE MARKER AND TAIL LAMP SYSTEM : System Description .....11</p> <p><b>FRONT FOG LAMP SYSTEM</b> .....11</p> <p style="padding-left: 20px;">FRONT FOG LAMP SYSTEM : System Diagram .....11</p> <p style="padding-left: 20px;">FRONT FOG LAMP SYSTEM : System Description ..... 11</p> <p><b>TRAILER TOW SYSTEM</b> .....12</p> <p style="padding-left: 20px;">TRAILER TOW SYSTEM : System Diagram .....12</p> <p style="padding-left: 20px;">TRAILER TOW SYSTEM : System Description .....12</p> <p><b>DIAGNOSIS SYSTEM (BCM)</b> .....13</p> <p><b>COMMON ITEM</b> .....13</p> <p style="padding-left: 20px;">COMMON ITEM : CONSULT Function (BCM - COMMON ITEM) ..... 13</p> <p><b>HEADLAMP</b> .....14</p> <p style="padding-left: 20px;">HEADLAMP : CONSULT Function (BCM - HEADLAMP) .....14</p> <p><b>FLASHER</b> .....15</p> <p style="padding-left: 20px;">FLASHER : CONSULT Function (BCM - FLASHER) .....15</p> <p><b>DIAGNOSIS SYSTEM (IPDM E/R)</b> .....16</p> <p style="padding-left: 20px;">Diagnosis Description .....16</p> <p style="padding-left: 20px;">CONSULT Function (IPDM E/R) .....17</p> <p><b>ECU DIAGNOSIS INFORMATION</b> .....20</p> <p><b>BCM, IPDM E/R</b> .....20</p> <p style="padding-left: 20px;">List of ECU Reference .....20</p> <p><b>WIRING DIAGRAM</b> .....21</p> <p><b>HEADLAMP</b> .....21</p> <p style="padding-left: 20px;">Wiring Diagram .....21</p>
---	--

<b>DAYTIME LIGHT SYSTEM</b> .....	29	Diagnosis Procedure .....	115
Wiring Diagram .....	29	<b>PARKING LAMP CIRCUIT</b> .....	117
<b>AUTO LIGHT SYSTEM</b> .....	40	Description .....	117
Wiring Diagram .....	40	Component Function Check .....	117
<b>FRONT FOG LAMP SYSTEM</b> .....	48	Diagnosis Procedure .....	117
Wiring Diagram .....	48	<b>TURN SIGNAL LAMP CIRCUIT</b> .....	121
<b>TURN SIGNAL AND HAZARD WARNING LAMP SYSTEM</b> .....	56	Description .....	121
Wiring Diagram .....	56	Component Function Check .....	121
<b>PARKING, LICENSE PLATE AND TAIL LAMPS SYSTEM</b> .....	64	Diagnosis Procedure .....	121
Wiring Diagram .....	64	<b>OPTICAL SENSOR</b> .....	124
<b>STOP LAMP</b> .....	76	Description .....	124
Wiring Diagram .....	76	Component Function Check .....	124
<b>BACK-UP LAMP</b> .....	80	Diagnosis Procedure .....	124
Wiring Diagram .....	80	<b>HAZARD SWITCH</b> .....	127
<b>TRAILER TOW</b> .....	90	Component Function Check .....	127
Wiring Diagram .....	90	Diagnosis Procedure .....	127
<b>BASIC INSPECTION</b> .....	103	<b>SYMPTOM DIAGNOSIS</b> .....	129
<b>DIAGNOSIS AND REPAIR WORKFLOW</b> .....	103	<b>EXTERIOR LIGHTING SYSTEM SYMPTOMS</b> .....	129
Work Flow .....	103	Symptom Table .....	129
<b>DTC/CIRCUIT DIAGNOSIS</b> .....	106	<b>NORMAL OPERATING CONDITION</b> .....	131
<b>POWER SUPPLY AND GROUND CIRCUIT</b> ..	106	Description .....	131
<b>BCM (BODY CONTROL MODULE)</b> .....	106	<b>BOTH SIDE HEADLAMPS DO NOT SWITCH TO HIGH BEAM</b> .....	132
BCM (BODY CONTROL MODULE) : Diagnosis Procedure .....	106	Description .....	132
<b>IPDM E/R (INTELLIGENT POWER DISTRIBU- TION MODULE ENGINE ROOM)</b> .....	106	Diagnosis Procedure .....	132
IPDM E/R (INTELLIGENT POWER DISTRIBU- TION MODULE ENGINE ROOM) : Diagnosis Pro- cedure .....	106	<b>BOTH SIDE HEADLAMPS (LO) ARE NOT TURNED ON</b> .....	133
<b>HEADLAMP (HI) CIRCUIT</b> .....	108	Description .....	133
Description .....	108	Diagnosis Procedure .....	133
Component Function Check .....	108	<b>PARKING, LICENSE PLATE, SIDE MARKER AND TAIL LAMPS ARE NOT TURNED ON</b> ...	134
Diagnosis Procedure .....	108	Description .....	134
<b>HEADLAMP (LO) CIRCUIT</b> .....	110	Diagnosis Procedure .....	134
Description .....	110	<b>BOTH SIDE FRONT FOG LAMPS ARE NOT TURNED ON</b> .....	135
Component Function Check .....	110	Description .....	135
Diagnosis Procedure .....	110	Diagnosis Procedure .....	135
<b>DAYTIME LIGHT RELAY CIRCUIT</b> .....	112	<b>DAYTIME LIGHT SYSTEM INOPERATIVE</b> ....	136
Description .....	112	Description .....	136
Diagnosis Procedure .....	112	Diagnosis Procedure .....	136
Component Inspection .....	113	<b>PERIODIC MAINTENANCE</b> .....	137
<b>FRONT FOG LAMP CIRCUIT</b> .....	115	<b>HEADLAMP</b> .....	137
Description .....	115	Inspection .....	137
Component Function Check .....	115	Aiming Adjustment Procedure .....	138
		<b>FRONT FOG LAMP AIMING ADJUSTMENT</b> ..	140
		Aiming Adjustment .....	140

<b>REMOVAL AND INSTALLATION</b> .....	141	<b>BACK-UP LAMP</b> .....	152	
<b>FRONT COMBINATION LAMP</b> .....	141	Exploded View .....	152	A
Exploded View .....	141	Removal and Installation .....	152	
Removal and Installation .....	141	<b>LICENSE PLATE LAMP</b> .....	153	B
<b>FRONT FOG LAMP</b> .....	144	Exploded View .....	153	
Exploded View .....	144	Removal and Installation .....	153	
Removal and Installation .....	144	<b>UNIT DISASSEMBLY AND ASSEMBLY</b> .	155	C
<b>OPTICAL SENSOR</b> .....	146	<b>FRONT COMBINATION LAMP</b> .....	155	
Exploded View .....	146	Exploded View .....	155	D
Removal and Installation .....	146	Disassembly and Assembly .....	155	
<b>LIGHTING &amp; TURN SIGNAL SWITCH</b> .....	147	<b>REAR COMBINATION LAMP</b> .....	156	E
Removal and Installation .....	147	Exploded View .....	156	
<b>HAZARD SWITCH</b> .....	148	Disassembly and Assembly .....	156	
Removal and Installation .....	148	<b>SERVICE DATA AND SPECIFICATIONS</b>		F
<b>REAR COMBINATION LAMP</b> .....	149	<b>(SDS)</b> .....	157	
Exploded View .....	149	<b>SERVICE DATA AND SPECIFICATIONS</b>		G
Removal and Installation .....	149	<b>(SDS)</b> .....	157	
<b>HIGH-MOUNTED STOP LAMP</b> .....	151	Bulb Specifications .....	157	H
Removal and Installation .....	151			I
				J
				K
				EXL
				M
				N
				O
				P

# PRECAUTIONS

< PRECAUTION >

## PRECAUTION

### PRECAUTIONS

#### Precaution for Supplemental Restraint System (SRS) "AIR BAG" and "SEAT BELT PRE-TENSIONER"

INFOID:000000009175328

The Supplemental Restraint System such as "AIR BAG" and "SEAT BELT PRE-TENSIONER", used along with a front seat belt, helps to reduce the risk or severity of injury to the driver and front passenger for certain types of collision. Information necessary to service the system safely is included in the SR and SB section of this Service Manual.

#### **WARNING:**

- To avoid rendering the SRS inoperative, which could increase the risk of personal injury or death in the event of a collision which would result in air bag inflation, all maintenance must be performed by an authorized NISSAN/INFINITI dealer.
- Improper maintenance, including incorrect removal and installation of the SRS, can lead to personal injury caused by unintentional activation of the system. For removal of Spiral Cable and Air Bag Module, see the SR section.
- Do not use electrical test equipment on any circuit related to the SRS unless instructed to in this Service Manual. SRS wiring harnesses can be identified by yellow and/or orange harnesses or harness connectors.

#### PRECAUTIONS WHEN USING POWER TOOLS (AIR OR ELECTRIC) AND HAMMERS

#### **WARNING:**

- When working near the Airbag Diagnosis Sensor Unit or other Airbag System sensors with the Ignition ON or engine running, DO NOT use air or electric power tools or strike near the sensor(s) with a hammer. Heavy vibration could activate the sensor(s) and deploy the air bag(s), possibly causing serious injury.
- When using air or electric power tools or hammers, always switch the Ignition OFF, disconnect the battery and wait at least 3 minutes before performing any service.

#### Precaution for Work

INFOID:000000009175329

- When removing or disassembling each component, be careful not to damage or deform it. If a component may be subject to interference, be sure to protect it with a shop cloth.
- When removing (disengaging) components with a screwdriver or similar tool, be sure to wrap the component with a shop cloth or vinyl tape to protect it.
- Protect the removed parts with a shop cloth and prevent them from being dropped.
- Replace a deformed or damaged clip.
- If a part is specified as a non-reusable part, always replace it with a new one.
- Be sure to tighten bolts and nuts securely to the specified torque.
- After installation is complete, be sure to check that each part works properly.
- Follow the steps below to clean components:
  - Water soluble dirt:
    - Dip a soft cloth into lukewarm water, wring the water out of the cloth and wipe the dirty area.
    - Then rub with a soft, dry cloth.
  - Oily dirt:
    - Dip a soft cloth into lukewarm water with mild detergent (concentration: within 2 to 3%) and wipe the dirty area.
    - Then dip a cloth into fresh water, wring the water out of the cloth and wipe the detergent off.
    - Then rub with a soft, dry cloth.
  - Do not use organic solvent such as thinner, benzene, alcohol or gasoline.
  - For genuine leather seats, use a genuine leather seat cleaner.

# PREPARATION

< PREPARATION >

## PREPARATION

### PREPARATION

#### Special Service Tool

INFOID:000000009175330

The actual shapes of Kent-Moore tools may differ from those of special service tools illustrated here.

Tool number (Kent-Moore No.) Tool name	Description
— (J-46534) Trim Tool Set	Removing trim components

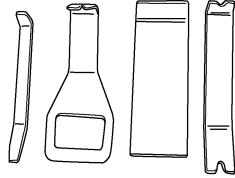

AWJIA0483ZZ

A  
B  
C  
D  
E  
F  
G  
H  
I  
J  
K  
EXL  
M  
N  
O  
P

# COMPONENT PARTS

< SYSTEM DESCRIPTION >

## SYSTEM DESCRIPTION

### COMPONENT PARTS

#### Component Parts Location

INFOID:000000009175331

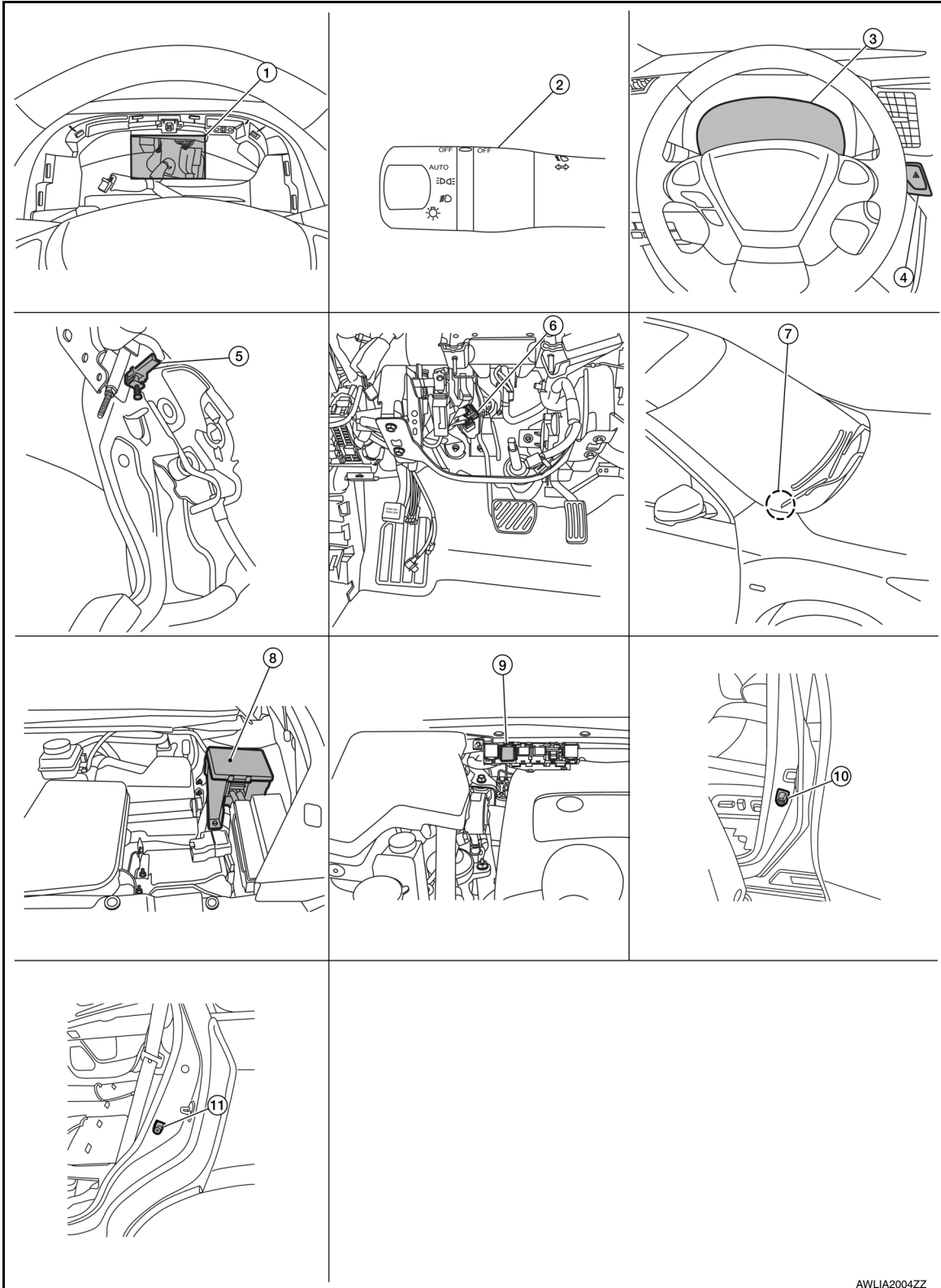

AWLIA2004ZZ

# COMPONENT PARTS

## < SYSTEM DESCRIPTION >

- |   |  |                                      |   |
|---|--|--------------------------------------|---|
| 1. BCM<br>(view with combination meter removed) | 2. Combination switch<br>(lighting and turn signal switch)   | 3. Combination meter                 | A |
| 4. Hazard switch                                | 5. Parking brake switch  | 6. Stop lamp switch                  | B |
| 7. Optical sensor (if equipped)                 | 8. IPDM E/R, [Headlamp high relay, Headlamp low relay, Taillamp relay, Front fog lamp relay (if equipped)] | 9. Daytime light relay (if equipped) | C |
| 10. Front door switch LH<br>(RH similar)        | 11. Rear door switch LH<br>(RH similar)  |                                      | D |

## Component Description

INFOID:000000009175332

Part	Description
BCM	Controls the exterior lighting system.
Combination switch (Lighting & turn signal switch)	Refer to <a href="#">BCS-8. "COMBINATION SWITCH READING SYSTEM : System Description"</a> .
IPDM E/R	Controls the integrated relays and supplies voltage to the load according to the request from the BCM via CAN communication.
Stop lamp switch	Transmits stop lamp switch signal to BCM when the brake pedal is pressed to operate stop lamps.
Combination meter	Refer to <a href="#">MWI-9. "METER SYSTEM : System Description"</a> .
Daytime light relay (if equipped)	Sends power to the daytime lamp when operated by the IPDM E/R.
Front door switch LH/RH	Transmits the door open signal to the BCM to operate the autolight system.
Rear door switch LH/RH	
Optical sensor (if equipped)	Optical sensor converts the outside brightness (lux) to voltage and transmits the optical sensor signal to BCM to operate the autolight system.
Parking brake switch	Transmits the parking brake switch signal to the combination meter to operate the daytime light system.
Hazard switch	Inputs the hazard switch signal to BCM.

A  
B  
C  
D  
E  
F  
G  
H  
I  
J  
K  
EXL  
M  
N  
O  
P

# SYSTEM

< SYSTEM DESCRIPTION >

## SYSTEM

### HEADLAMP SYSTEM

#### HEADLAMP SYSTEM : System Diagram

INFOID:000000009175333

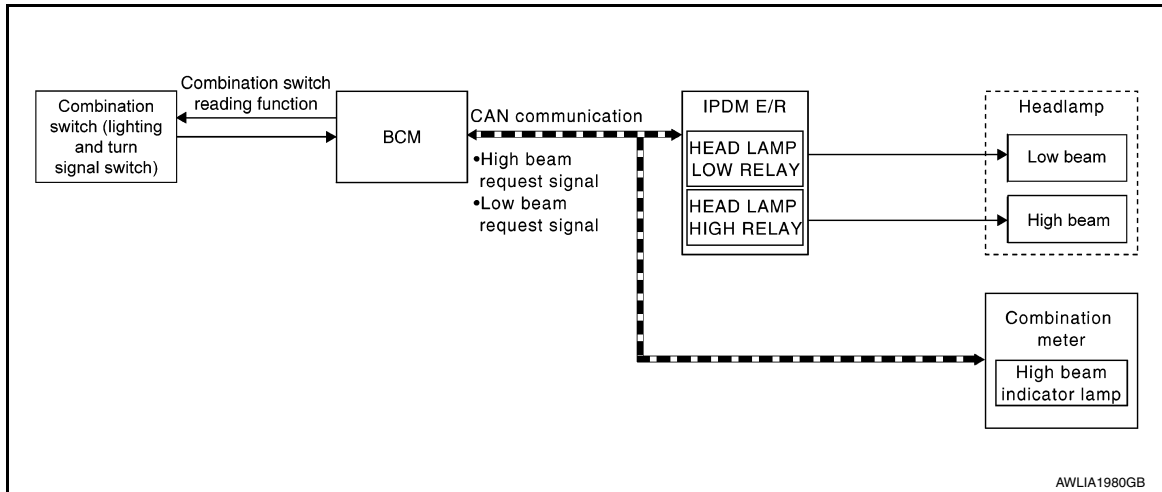

#### HEADLAMP SYSTEM : System Description

INFOID:000000009175334

##### LOW BEAM OPERATION

When the lighting switch is in the AUTO (if equipped and activated) or headlamp position, the BCM receives input requesting the headlamps to illuminate. This input is communicated to the IPDM E/R across the CAN communication lines. The CPU of the IPDM E/R controls the headlamp low relay coil which supplies power to the low beam headlamps.

##### HIGH BEAM OPERATION/FLASH-TO-PASS OPERATION

With the lighting switch in the AUTO (if equipped and activated) or headlamp position and placed in HIGH position, the BCM receives input requesting the headlamp high beams to illuminate. The flash to pass feature can be used any time and also sends a signal to the BCM. This input is communicated to the IPDM E/R across the CAN communication lines. The CPU of the combination meter controls the ON/OFF status off the HIGH BEAM indicator. The CPU of the IPDM E/R controls the headlamp high relay coil which supplies power to the high beam headlamps.

The combination meter receives a high beam request signal (ON) through the CAN communication lines and turns the high beam indicator lamp ON.

##### EXTERIOR LAMP BATTERY SAVER CONTROL

With the combination switch (lighting and turn signal switch) in the AUTO (if equipped and activated) parking lamp or headlamp position and the ignition switch is turned from ON or ACC to OFF, the battery saver feature is activated.

Under this condition, the headlamps remain illuminated for 45 seconds, unless the lighting switch position is changed. If the lighting switch position is changed, then the headlamps are turned off.

##### AUTO LIGHT SYSTEM



# SYSTEM

< SYSTEM DESCRIPTION >

## AUTO LIGHT SYSTEM : System Diagram

INFOID:000000009175335

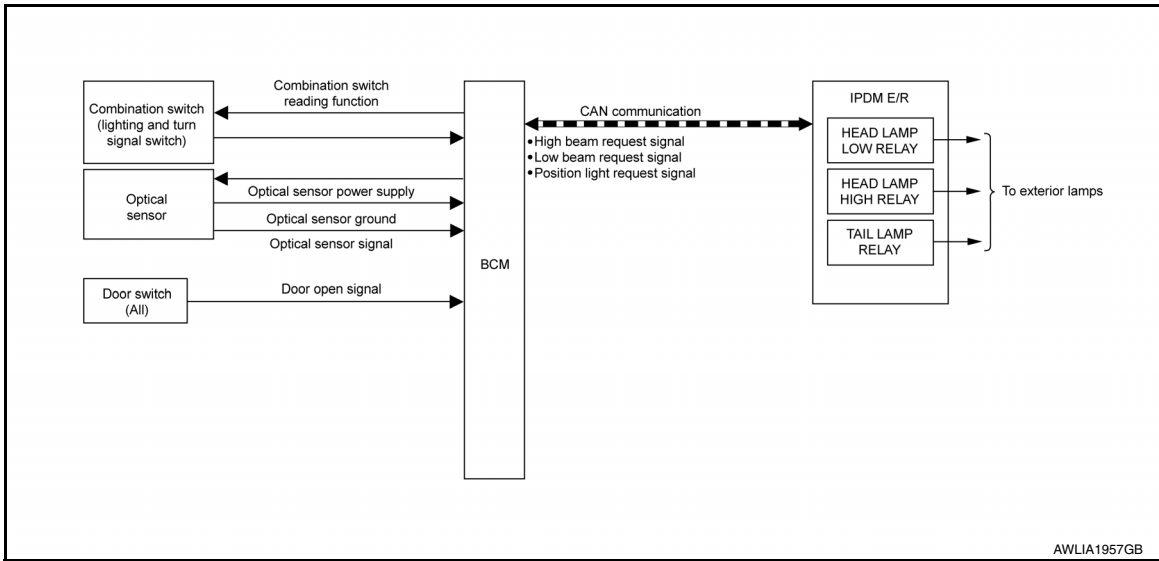

## AUTO LIGHT SYSTEM : System Description

INFOID:000000009175336

- BCM (Body Control Module) controls auto light operation according to signals from optical sensor, lighting switch and ignition switch.
- IPDM E/R (Intelligent Power Distribution Module Engine Room) operates parking, license plate, tail, front fog lamps and headlamps according to CAN communication signals from BCM.
- Optical sensor detects ambient brightness of 800 to 2,500 lux. And optical sensor converts light (lux) to voltage, then sends the optical sensor signal to BCM.

### OUTLINE

The auto light control system has an optical sensor that detects outside brightness. When the lighting switch is in AUTO position, it automatically turns ON/OFF the parking, license plate, tail, front fog lamps and headlamps in accordance with the ambient light. Sensitivity can be adjusted in four steps. For the details of the setting, Refer to [BCS-18, "HEADLAMP : CONSULT Function \(BCM - HEADLAMP\)"](#).

### WIPER LINKED AUTO LIGHTING FUNCTION (if equipped)

With the lighting switch in the AUTO position, the BCM will turn on the exterior lamps after detecting 4 operations of the front wiper. The BCM will turn off the exterior lamps 3 seconds after the front wiper switch is turned to the OFF position.

## DAYTIME RUNNING LIGHT SYSTEM

### DAYTIME RUNNING LIGHT SYSTEM : System Diagram

INFOID:000000009175337

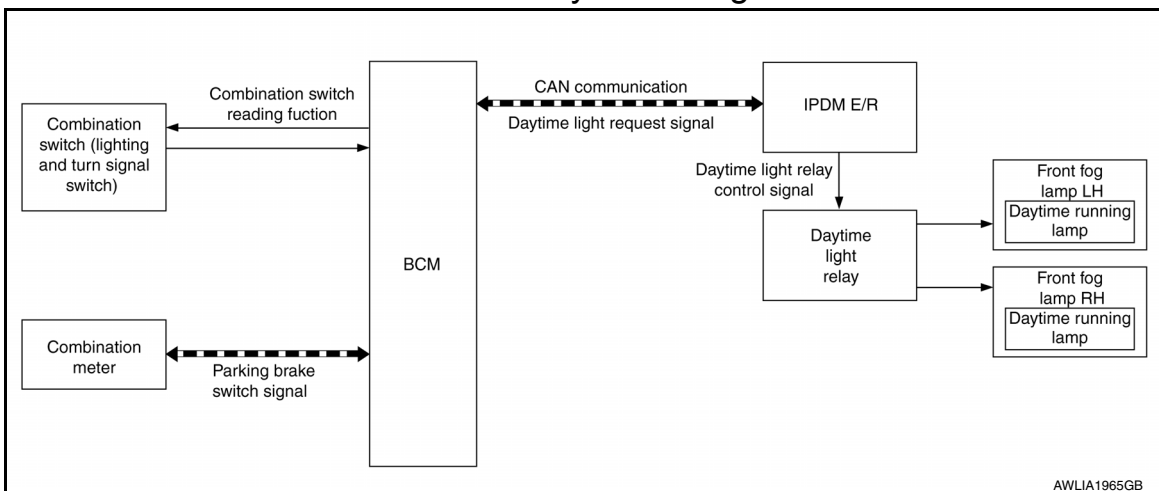

# SYSTEM

< SYSTEM DESCRIPTION >

## DAYTIME RUNNING LIGHT SYSTEM : System Description

INFOID:000000009175338

### System Description

The daytime light system is equipped with a daytime light control that activates the daytime lights within the front fog lamp assembly when the engine is operating. If the parking brake is applied, the daytime lights will turn OFF. The daytime lights will turn ON when the parking brake is released.

### OPERATION

The BCM monitors inputs from the parking brake switch and the combination switch (lighting and turn signal switch) to determine when to operate the daytime light system. The BCM sends a daytime light request to the IPDM E/R via the CAN communication lines. The IPDM E/R grounds the daytime light relay which in turn, provides power to the daytime lights.

## TURN SIGNAL AND HAZARD WARNING LAMP SYSTEM

### TURN SIGNAL AND HAZARD WARNING LAMP SYSTEM : System Diagram

INFOID:000000009175339

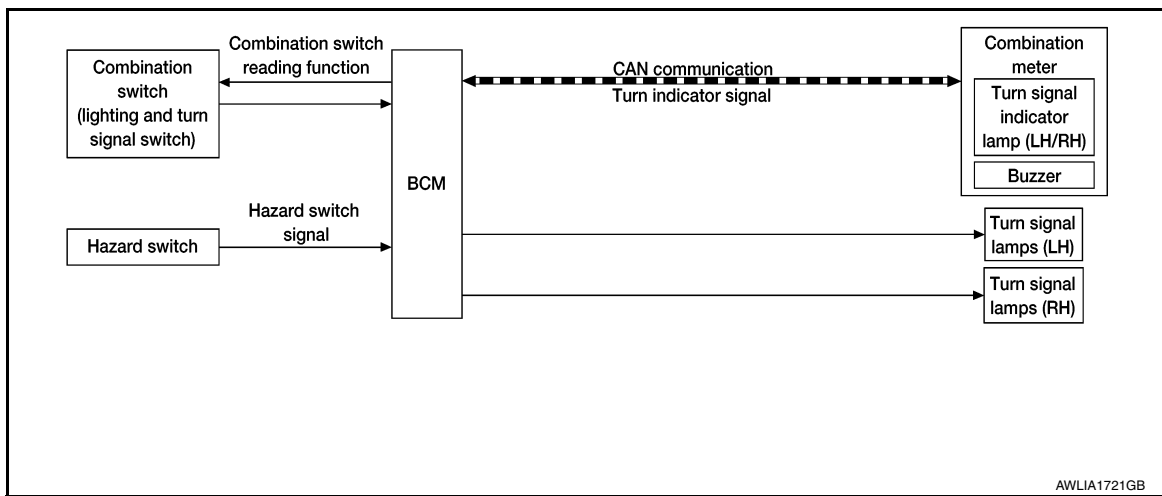

### TURN SIGNAL AND HAZARD WARNING LAMP SYSTEM : System Description

INFOID:000000009175340

#### TURN SIGNAL OPERATION

When the combination switch (lighting and turn signal switch) is in LH or RH turn position with the ignition switch in the ON position, the BCM receives input requesting the turn RH or turn LH lamps to illuminate. The BCM controls the turn signal power to the respective turn signal lamp. The BCM also sends a turn indicator signal ON request via the CAN communication lines to the combination meter. The combination meter then activates the appropriate turn signal indicator and audible buzzer.

#### HAZARD LAMP OPERATION

When the hazard switch is in the ON position, the BCM receives input requesting the hazard lamps illuminate. The BCM controls the turn signal power to both the LH and RH turn signal lamps. The BCM sends a hazard indicator signal ON request via the CAN communication lines to the combination meter. The combination meter then activates both the LH and RH turn signal indicators and audible buzzer.

## PARKING, LICENSE PLATE, SIDE MARKER AND TAIL LAMP SYSTEM

### PARKING, LICENSE PLATE, SIDE MARKER AND TAIL LAMP SYSTEM : System Di-

# SYSTEM

## < SYSTEM DESCRIPTION >

agram

INFOID:000000009175341

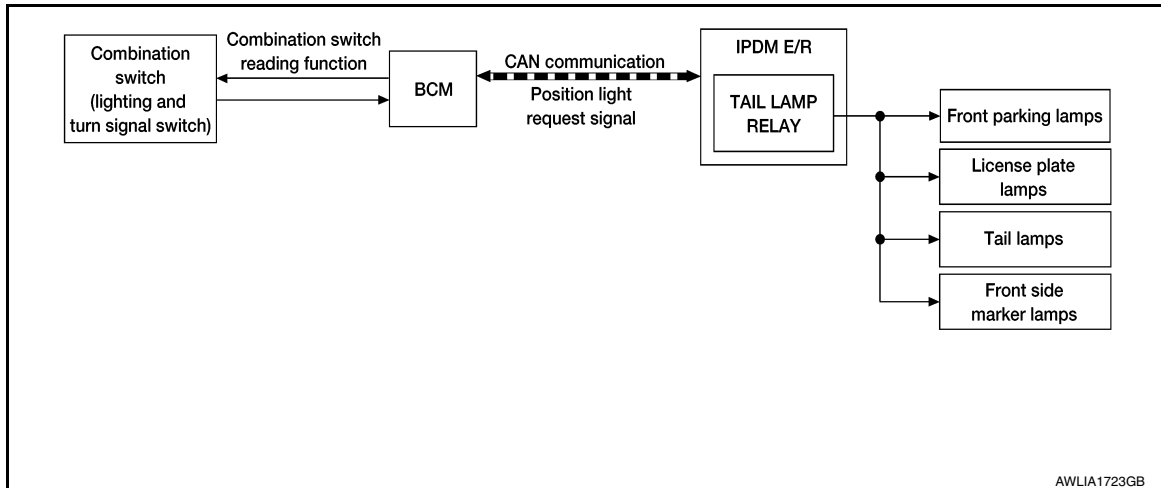

AWLIA1723GB

## PARKING, LICENSE PLATE, SIDE MARKER AND TAIL LAMP SYSTEM : System Description

INFOID:000000009175342

### PARKING, LICENSE PLATE AND TAIL LAMPS OPERATION

With the lighting switch is in the AUTO (if equipped and activated) or parking lamp position, the BCM receives input requesting the parking lamps to illuminate. The BCM sends a parking light ON request via the CAN communication lines to the IPDM E/R. The IPDM E/R then activates the tail lamp relay which sends power to the parking and instrument illumination circuits.

### EXTERIOR LAMP BATTERY SAVER CONTROL

With the combination switch (lighting and turn signal switch) in the AUTO (if equipped and activated) or parking lamp position and the ignition switch is turned from ON or ACC to OFF, the battery saver feature is activated.

Under this condition, the exterior lamps remain illuminated for 45 seconds unless the lighting switch position is changed. If the lighting switch position is changed, then the exterior lamps are turned off.

## FRONT FOG LAMP SYSTEM

### FRONT FOG LAMP SYSTEM : System Diagram

INFOID:000000009175343

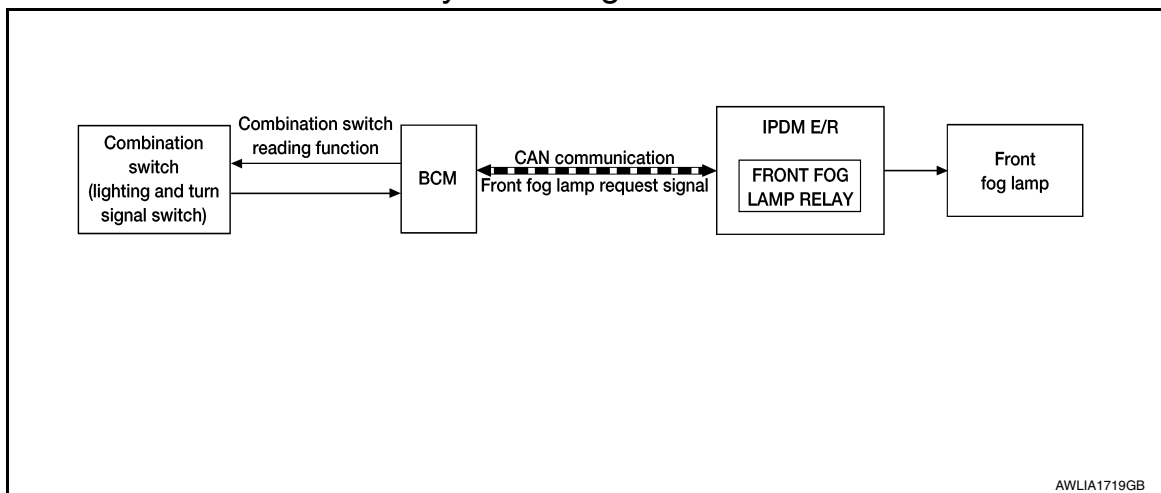

AWLIA1719GB

## FRONT FOG LAMP SYSTEM : System Description

INFOID:000000009175344

The front fog lamps are activated with the combination switch (lighting and turn signal switch). The lighting switch signal to the BCM is monitored with the BCM combination switch reading function. When the fog lamps are turned ON with the lighting switch, the BCM sends a front fog lamp request signal via CAN communication lines to the IPDM E/R. The IPDM E/R grounds the front fog lamp relay coil to activate the front fog lamps.

A  
B  
C  
D  
E  
F  
G  
H  
I  
J  
K  
EXL  
M  
N  
O  
P

# SYSTEM

## < SYSTEM DESCRIPTION >

### FRONT FOG LAMP OPERATION

When the lighting switch position is in the AUTO (if equipped and activated) or headlamp, and the front fog lamp position, the BCM detects front fog lamp signal and then sends a front fog lamp request ON signal via the CAN communication lines to the IPDM E/R. The IPDM E/R then turns ON the front fog lamp relay sending power to the front fog lamps.

### TRAILER TOW SYSTEM

#### TRAILER TOW SYSTEM : System Diagram

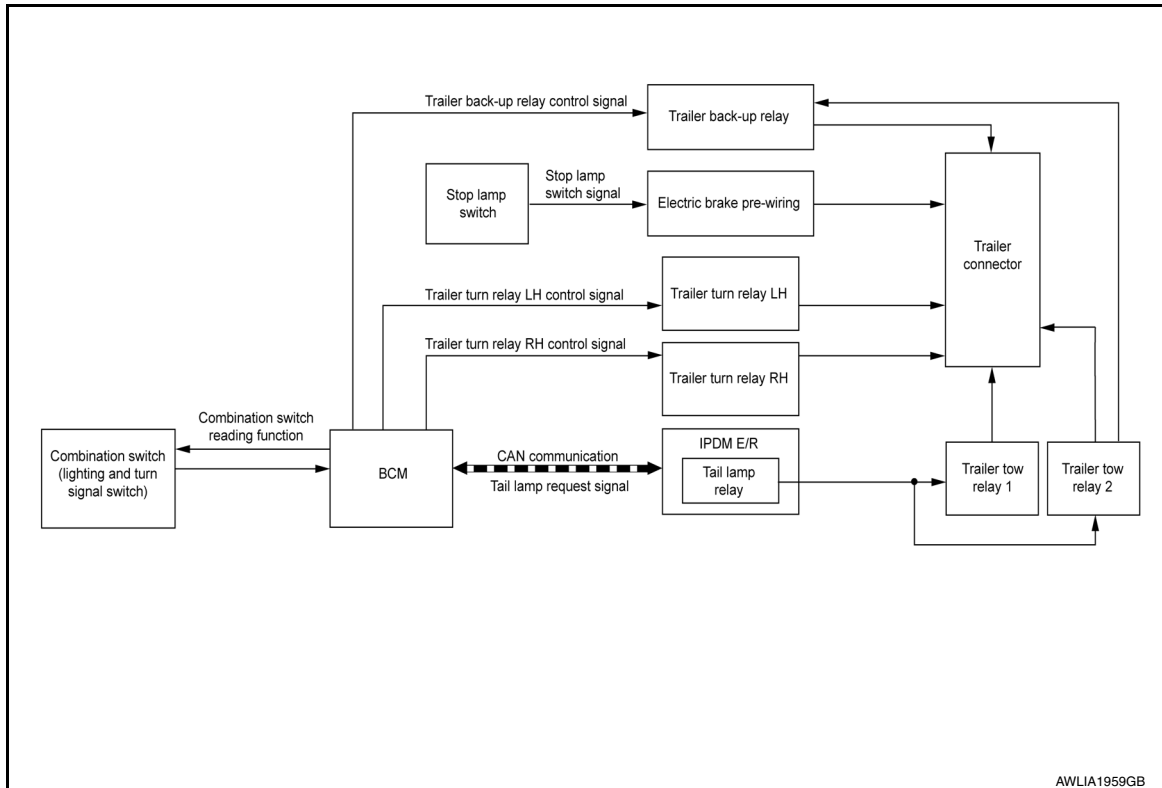

#### TRAILER TOW SYSTEM : System Description

INFOID:000000009175346

### TRAILER TAIL LAMP OPERATION

The trailer tail lamps are controlled by the trailer tow relay 1. With the combination switch (lighting and turn signal switch) in the AUTO (if equipped and activated) or parking lamp position, the BCM detects the lighting switch signal and then sends a parking light ON request via the CAN communication lines to the IPDM E/R. The IPDM E/R then activates the tail lamp relay which activates the trailer tow relay 1 and sends power to the trailer connector.

### TRAILER TURN SIGNAL LAMP OPERATION

The trailer turn signal lamps are controlled by the BCM. When the turn signal switch is in the LH or RH position with the ignition switch ON, the combination switch (lighting and turn signal switch) sends a signal to the BCM. The BCM detects the TURN RH or TURN LH ON request. The BCM sends a control signal to the respective trailer turn relay which sends power to the trailer connector.

### TRAILER HAZARD LAMP OPERATION

The trailer hazard lamps are controlled by the BCM. When the hazard switch is pressed, the BCM detects the hazard ON request. The BCM then sends a control signal to both trailer turn relays which sends power to the trailer connector.

### TRAILER BRAKE LAMP OPERATION

The trailer brake lamps operate when the brake pedal is pressed sending the stop lamp switch signal to the trailer connector.

# DIAGNOSIS SYSTEM (BCM)

< SYSTEM DESCRIPTION >

## DIAGNOSIS SYSTEM (BCM)

### COMMON ITEM

COMMON ITEM : CONSULT Function (BCM - COMMON ITEM)

INFOID:000000009764001

**CAUTION:**

After disconnecting the CONSULT vehicle interface (VI) from the data link connector, the ignition must be cycled OFF → ON (for at least 5 seconds) → OFF. If this step is not performed, the BCM may not go to "sleep mode", potentially causing a discharged battery and no-start condition.

### APPLICATION ITEM

CONSULT performs the following functions via CAN communication with BCM.

Direct Diagnostic Mode	Description
Ecu Identification	The BCM part number is displayed.
Self Diagnostic Result	The BCM self diagnostic results are displayed.
Data Monitor	The BCM input/output data is displayed in real time.
Active Test	The BCM activates outputs to test components.
Work support	The settings for BCM functions can be changed.
Configuration	<ul style="list-style-type: none"> <li>The vehicle specification can be read and saved.</li> <li>The vehicle specification can be written when replacing BCM.</li> </ul>
CAN Diag Support Mntr	The result of transmit/receive diagnosis of CAN communication is displayed.

### SYSTEM APPLICATION

BCM can perform the following functions.

System	Sub System	Direct Diagnostic Mode						
		Ecu Identification	Self Diagnostic Result	Data Monitor	Active Test	Work support	Configuration	CAN Diag Support Mntr
Door lock	DOOR LOCK		×	×	×	×		
Rear window defogger	REAR DEFOGGER			×	×	×		
Warning chime	BUZZER			×	×			
Interior room lamp timer	INT LAMP			×	×	×		
Exterior lamp	HEADLAMP			×	×	×		
Wiper and washer	WIPER			×	×	×		
Turn signal and hazard warning lamps	FLASHER			×	×			
Air conditioner	AIR CONDITIONER			×				
Intelligent Key system	INTELLIGENT KEY		×	×	×	×		
Combination switch	COMB SW			×				
BCM	BCM	×	×			×	×	×
Immobilizer	IMMU		×	×	×			
Interior room lamp battery saver	BATTERY SAVER			×	×			
Back door open	TRUNK			×				
Vehicle security system	THEFT ALM			×	×	×		
RAP system	RETAINED PWR			×				

# DIAGNOSIS SYSTEM (BCM)

## < SYSTEM DESCRIPTION >

System	Sub System	Direct Diagnostic Mode						
		Ecu Identification	Self Diagnostic Result	Data Monitor	Active Test	Work support	Configuration	CAN Diag Support Mntr
Signal buffer system	SIGNAL BUFFER			×				
TPMS	AIR PRESSURE MONITOR		×	×	×	×		

## HEADLAMP

### HEADLAMP : CONSULT Function (BCM - HEADLAMP)

INFOID:000000009764002

#### CAUTION:

After disconnecting the CONSULT vehicle interface (VI) from the data link connector, the ignition must be cycled OFF → ON (for at least 5 seconds) → OFF. If this step is not performed, the BCM may not go to "sleep mode", potentially causing a discharged battery and no-start condition.

## DATA MONITOR

Monitor Item [Unit]	Description
PUSH SW [On/Off]	Indicates condition of push-button ignition switch.
ENGINE STATE [STOP/STALL/CRANK/RUN]	Indicates engine status received from ECM on CAN communication line.
VEH SPEED 1 [km/h]	Indicates vehicle speed signal received from ABS on CAN communication line.
TURN SIGNAL R [On/Off]	Indicates condition of combination switch.
TURN SIGNAL L [On/Off]	
TAIL LAMP SW [On/Off]	
HI BEAM SW [On/Off]	
HEAD LAMP SW 1 [On/Off]	
HEAD LAMP SW 2 [On/Off]	
PASSING SW [On/Off]	
AUTO LIGHT SW [On/Off]	
FR FOG SW [On/Off]	
DOOR SW-DR [On/Off]	
DOOR SW-AS [On/Off]	Indicates condition of front door switch RH.
DOOR SW-RR [On/Off]	Indicates condition of rear door switch RH.
DOOR SW-RL [On/Off]	Indicates condition of rear door switch LH.
DOOR SW-BK [On/Off]	Indicates condition of back door switch.
OPTI SEN (DTCT) [V]	Indicates outside brightness voltage signal from optical sensor.
OPTI SEN (FILT) [V]	Indicates outside brightness voltage signal from optical sensor filtered by BCM.

## ACTIVE TEST

Test Item	Description
FR FOG LAMP	This test is able to check front fog lamp operation [On/Off].
DAYTIME RUNNING LIGHT	This test is able to check daytime running lamp operation [On/Off].
ILL DIM SIGNAL	This test is able to check head lamp illumination dimming operation [On/Off].

# DIAGNOSIS SYSTEM (BCM)

< SYSTEM DESCRIPTION >

## WORK SUPPORT

Support Item	Setting	Description
TWILIGHT ON	MODE2*	Autolamp function ON.
	MODE1	Autolamp function OFF.
WIPER LINK	MODE4	This mode is not used.
	MODE3*	Wiper link function operates in INT, LOW and HI.
	MODE2	Wiper link function operates in LOW and HI.
CUSTOM A/LIGHT SETTING	MODE1	Wiper link function OFF.
	MODE4	Less sensitive than normal setting (turns ON later).
	MODE3	More sensitive than MODE2.
	MODE2	More sensitive than normal setting (turns ON earlier).
ILL DELAY SET	MODE1*	Normal setting.
	MODE 8	Autolamp delay timer.
	MODE 7	
	MODE 6	
	MODE 4	
	MODE 5	
	MODE 3	
MODE 2		
MODE 1*		

\* : Initial setting

## FLASHER

### FLASHER : CONSULT Function (BCM - FLASHER)

INFOID:000000009764003

#### CAUTION:

After disconnecting the CONSULT vehicle interface (VI) from the data link connector, the ignition must be cycled OFF → ON (for at least 5 seconds) → OFF. If this step is not performed, the BCM may not go to "sleep mode", potentially causing a discharged battery and no-start condition.

## DATA MONITOR

EXL

Monitor Item [Unit]	Description
REQ SW -DR [On/Off]	Indicates condition of door request switch LH.
REQ SW -AS [On/Off]	Indicates condition of door request switch RH.
PUSH SW [On/Off]	Indicates condition of push-button ignition switch.
TURN SIGNAL R [On/Off]	Indicates condition of turn signal function of combination switch.
TURN SIGNAL L [On/Off]	
HAZARD SW [On/Off]	Indicates condition of hazard switch.
RKE-LOCK [On/Off]	Indicates condition of lock signal from Intelligent Key.
RKE-UNLOCK [On/Off]	Indicates condition of unlock signal from Intelligent Key.
RKE-PANIC [On/Off]	Indicates condition of panic alarm signal from Intelligent Key.

## ACTIVE TEST

Test Item	Description
FLASHER	This test is able to check turn signal lamp operation [Off/LH/RH].

# DIAGNOSIS SYSTEM (IPDM E/R)

< SYSTEM DESCRIPTION >

## DIAGNOSIS SYSTEM (IPDM E/R)

### Diagnosis Description

INFOID:000000009764005

#### AUTO ACTIVE TEST

##### Description

In auto active test mode, the IPDM E/R sends a drive signal to the following systems to check their operation.

- Front wiper (LO, HI)
- Front fog lamps
- Parking lamps
- Side marker lamps
- Tail lamps
- License plate lamps
- Daytime running lamps
- Headlamps (LO, HI)
- A/C compressor
- Cooling fans (LO, HI)

##### Operation Procedure

##### **CAUTION:**

**Do not start the engine.**

##### **NOTE:**

When auto active test is performed with hood opened, sprinkle water on windshield before hand.

##### **NOTE:**

- If auto active test mode cannot be actuated, check door switch system. Refer to [DLK-170, "Component Function Check"](#).
  - When auto active test mode has to be cancelled halfway through test, turn ignition switch OFF.
1. Close the hood and lift the wiper arms from the windshield. (Prevent windshield damage due to wiper operation)
  2. Turn ignition switch OFF.
  3. Turn the ignition switch ON, and within 20 seconds, press the front door switch LH 10 times. Then turn the ignition switch OFF.
  4. Turn the ignition switch ON within 10 seconds. After that the horn sounds once, and the auto active test starts.
  5. After a series of the following operations is repeated 3 times, auto active test is completed.

##### Inspection in Auto Active Test Mode

When auto active test mode is actuated, the following operation sequence is repeated 3 times.

Operation sequence	Inspection Location	Operation
1	Front wiper	LO for 3 seconds → HI for 3 seconds
2	<ul style="list-style-type: none"><li>• Front fog lamps</li><li>• Parking lamps</li><li>• Side marker lamps</li><li>• Tail lamps</li><li>• License plate lamps</li></ul>	10 seconds
3	Daytime running lamps	10 seconds
4	Headlamps	LO ⇔ HI 5 times
5	A/C compressor	ON ⇔ OFF 5 times
6*	Cooling fans	LO for 5 seconds → HI for 5 seconds

\*: Outputs duty ratio of 50% for 5 seconds → duty ratio of 100% for 5 seconds on the cooling fan control module.



# DIAGNOSIS SYSTEM (IPDM E/R)

## < SYSTEM DESCRIPTION >

### Concept of auto active test

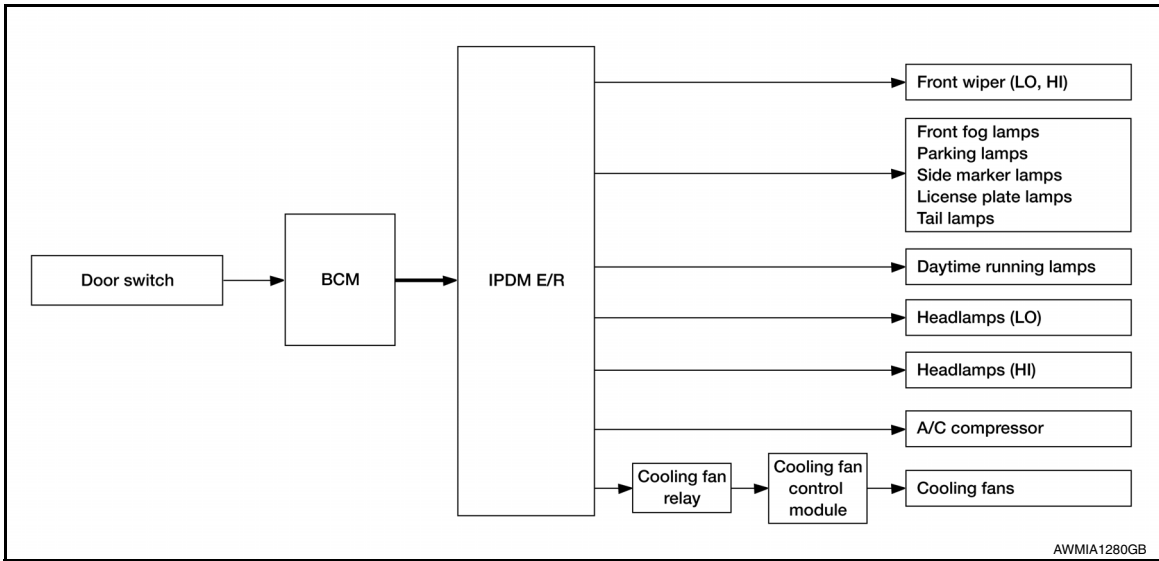

- IPDM E/R starts the auto active test with the door switch signals transmitted by BCM via CAN communication. Therefore, the CAN communication line between IPDM E/R and BCM is considered normal if the auto active test starts successfully.
- The auto active test facilitates troubleshooting if any systems controlled by IPDM E/R cannot be operated.

### Diagnosis chart in auto active test mode

Symptom	Inspection contents	Possible cause
Any of the following components do not operate <ul style="list-style-type: none"> <li>• Front fog lamps</li> <li>• Parking lamps</li> <li>• Side marker lamps</li> <li>• License plate lamps</li> <li>• Tail lamps</li> <li>• Daytime running lamps</li> <li>• Headlamp (HI, LO)</li> <li>• Front wiper</li> </ul>	Perform auto active test. Does the applicable system operate?	YES BCM signal input circuit
		NO • Lamp or motor • Lamp or motor ground circuit • Harness or connector between IPDM E/R and applicable system • IPDM E/R
Cooling fans do not operate	Perform auto active test. Do the cooling fans operate?	YES • ECM signal input circuit • CAN communication signal between ECM and IPDM E/R
		NO • Cooling fans • Harness or connectors between cooling fans and cooling fan control module • Cooling fan control module • Harness or connectors between cooling fan relay and cooling fan control module • Cooling fan relay • Harness or connectors between IPDM E/R and cooling fan relay • IPDM E/R

## CONSULT Function (IPDM E/R)

INFOID:000000009764006

### CAUTION:

After disconnecting the CONSULT vehicle interface (VI) from the data link connector, the ignition must be cycled OFF → ON (for at least 5 seconds) → OFF. If this step is not performed, the BCM may not go to "sleep mode", potentially causing a discharged battery and no-start condition.

## DIAGNOSIS SYSTEM (IPDM E/R)

### < SYSTEM DESCRIPTION >

#### APPLICATION ITEM

CONSULT performs the following functions via CAN communication with IPDM E/R.

Direct Diagnostic Mode	Description
Ecu Identification	The IPDM E/R part number is displayed.
Self Diagnostic Result	The IPDM E/R self diagnostic results are displayed.
Data Monitor	The IPDM E/R input/output data is displayed in real time.
Active Test	The IPDM E/R activates outputs to test components.
CAN Diag Support Mntr	The result of transmit/receive diagnosis of CAN communication is displayed.

#### ECU IDENTIFICATION

The IPDM E/R part number is displayed.

#### SELF DIAGNOSTIC RESULT

Refer to [PCS-20, "DTC Index"](#).

#### DATA MONITOR

Monitor Item [Unit]	Main Signals	Description
RAD FAN REQ [%]	×	Indicates cooling fan speed signal received from ECM on CAN communication line
AC COMP REQ [On/Off]	×	Indicates A/C compressor request signal received from ECM on CAN communication line
TAIL&CLR REQ [On/Off]	×	Indicates position light request signal received from BCM on CAN communication line
HL LO REQ [On/Off]	×	Indicates low beam request signal received from BCM on CAN communication line
HL HI REQ [On/Off]	×	Indicates high beam request signal received from BCM on CAN communication line
FR FOG REQ [On/Off]	×	Indicates front fog light request signal received from BCM on CAN communication line
FR WIP REQ [Stop/1LOW/Low/Hi]	×	Indicates front wiper request signal received from BCM on CAN communication line
WIP AUTO STOP [STOP P/ACT P]	×	Indicates condition of front wiper auto stop signal
WIP PROT [Off/BLOCK]	×	Indicates condition of front wiper fail-safe operation
IGN RLY1 -REQ [On/Off]		Indicates ignition switch ON signal received from BCM on CAN communication line
IGN RLY [On/Off]	×	Indicates condition of ignition relay
PUSH SW [On/Off]		Indicates condition of push-button ignition switch
INTER/NP SW [On/Off]		Indicates condition of CVT shift position
ST RLY CONT [On/Off]		Indicates starter relay status signal received from BCM on CAN communication line
IHBT RLY -REQ [On/Off]		Indicates starter control relay signal received from BCM on CAN communication line
ST/INH RLY [Off/ ST /INH]		Indicates condition of starter relay and starter control relay
DETENT SW [On/Off]		Indicates condition of CVT shift selector (park position switch)
DTRL REQ [Off]		Indicates daytime light request signal received from BCM on CAN communication line
HOOD SW [On/Off]		Indicates condition of hood switch
THFT HRN REQ [On/Off]		Indicates theft warning horn request signal received from BCM on CAN communication line

# DIAGNOSIS SYSTEM (IPDM E/R)

## < SYSTEM DESCRIPTION >

Monitor Item [Unit]	Main Signals	Description
HORN CHIRP [On/Off]		Indicates horn reminder signal received from BCM on CAN communication line
HOOD SW 2 [On/Off]		Indicates condition of hood switch

## ACTIVE TEST

Test item	Description
HORN	This test is able to check horn operation [On].
FRONT WIPER	This test is able to check wiper motor operation [Hi/Lo/Off].
MOTOR FAN	This test is able to check cooling fan operation [4/3/2/1].
EXTERNAL LAMPS	This test is able to check external lamp operation [Fog/Hi/Lo/Tail/Off].

## CAN DIAG SUPPORT MNTR

Refer to [LAN-17. "CAN Diagnostic Support Monitor"](#).

A  
B  
C  
D  
E  
F  
G  
H  
I  
J  
K  
M  
N  
O  
P

**EXL**

## BCM, IPDM E/R

< ECU DIAGNOSIS INFORMATION >

# ECU DIAGNOSIS INFORMATION

BCM, IPDM E/R

List of ECU Reference

INFOID:000000009175352

ECU	Reference
BCM	<a href="#">BCS-30, "Reference Value"</a>
	<a href="#">BCS-50, "Fail Safe"</a>
	<a href="#">BCS-50, "DTC Inspection Priority Chart"</a>
	<a href="#">BCS-52, "DTC Index"</a>
IPDM E/R	<a href="#">PCS-12, "Reference Value"</a>
	<a href="#">PCS-19, "Fail Safe"</a>
	<a href="#">PCS-20, "DTC Index"</a>

# HEADLAMP

< WIRING DIAGRAM >

## WIRING DIAGRAM

### HEADLAMP

#### Wiring Diagram

INFOID:000000009175353

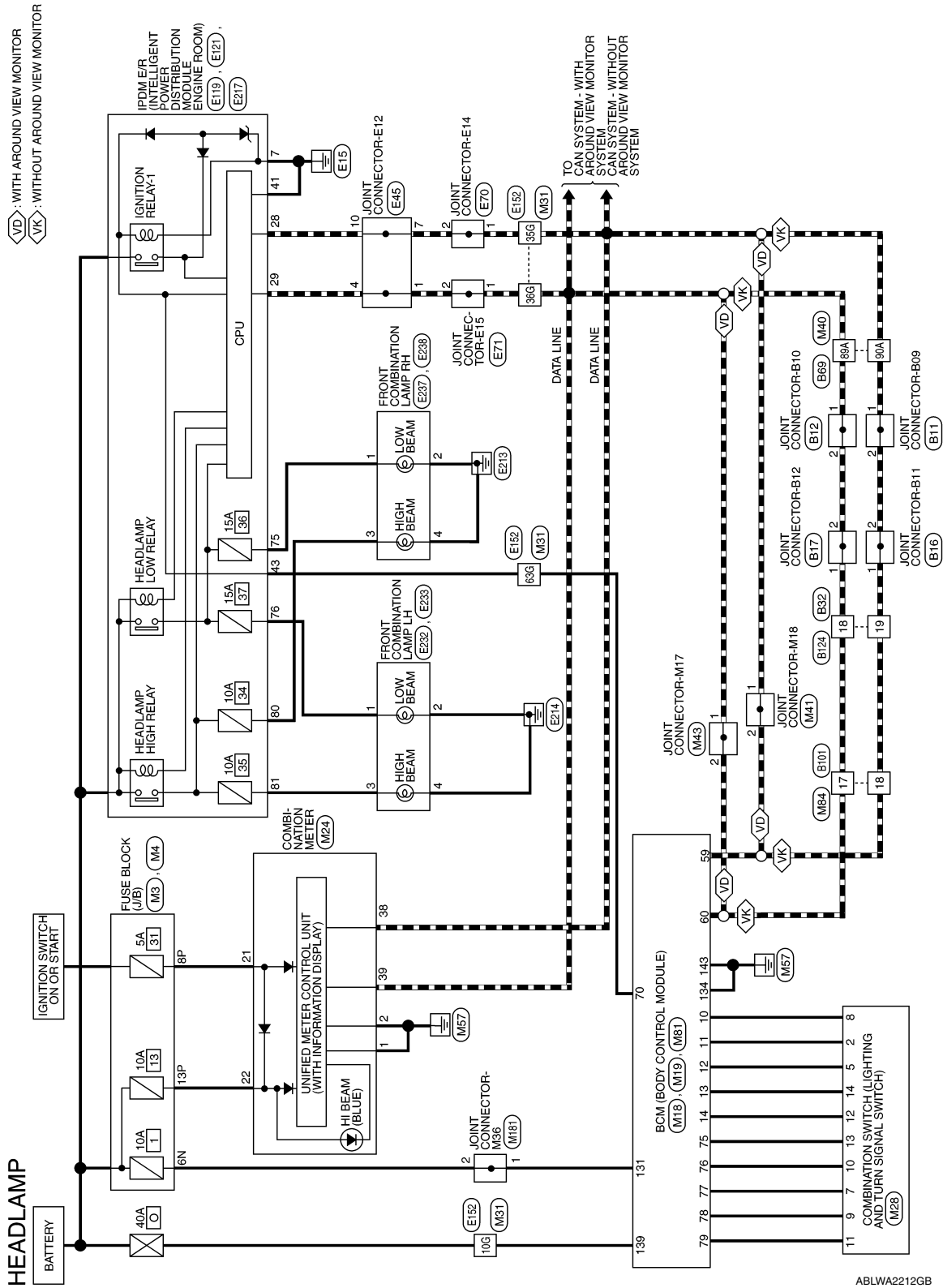

ABLWA2212GB

A  
B  
C  
D  
E  
F  
G  
H  
I  
J  
K  
L  
M  
N  
O  
P

EXL

# HEADLAMP

< WIRING DIAGRAM >

## HEADLAMP CONNECTORS

Connector No.	M3
Connector Name	FUSE BLOCK (J/B)
Connector Color	WHITE

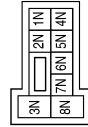

Terminal No.	Color of Wire	Signal Name
6N	W	-

Connector No.	M4
Connector Name	FUSE BLOCK (J/B)
Connector Color	WHITE



Terminal No.	Color of Wire	Signal Name
8P	BG	-
13P	W	-

Connector No.	M18
Connector Name	BCM (BODY CONTROL MODULE)
Connector Color	GREEN

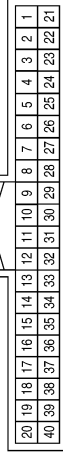

Terminal No.	Color of Wire	Signal Name
10	W	COMBI SW IN 5
11	BG	COMBI SW IN 4
12	R	COMBI SW IN 3
13	G	COMBI SW IN 2
14	P	COMBI SW IN 1

Connector No.	M19
Connector Name	BCM (BODY CONTROL MODULE)
Connector Color	BLACK

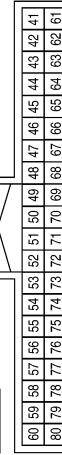

Terminal No.	Color of Wire	Signal Name
59	P	CAN-L
60	L	CAN-H
70	P	IGN USM OUT 1
75	BG	COMBI SW OUT 5
76	P	COMBI SW OUT 4
77	R	COMBI SW OUT 3
78	G	COMBI SW OUT 2
79	W	COMBI SW OUT 1

Connector No.	M24
Connector Name	COMBINATION METER
Connector Color	WHITE

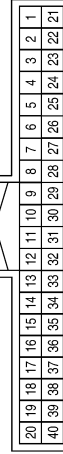

Terminal No.	Color of Wire	Signal Name
1	B	GND1
2	B	GND2
21	BG	IGN
22	W	BAT
38	P	CAN-L
39	L	CAN-H

# HEADLAMP

< WIRING DIAGRAM >

Connector No.	M28
Connector Name	COMBINATION SWITCH
Connector Color	WHITE

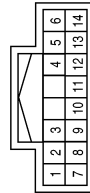

Terminal No.	Color of Wire	Signal Name
2	BG	-
5	R	-
7	R	-
8	W	-
9	G	-
10	P	-
11	W	-
12	P	-
13	BG	-
14	G	-

Connector No.	M31
Connector Name	WIRE TO WIRE
Connector Color	WHITE

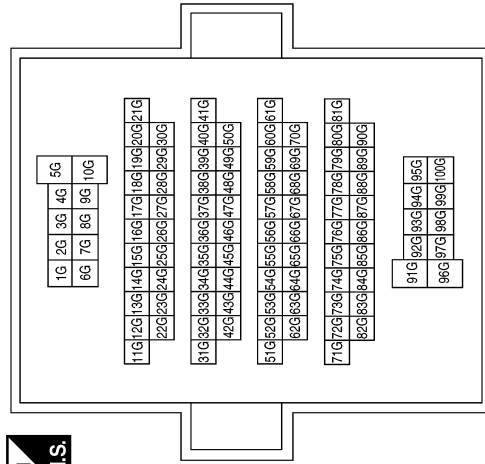

Terminal No.	Color of Wire	Signal Name
10G	W	-
35G	P	-
36G	L	-
63G	P	-

Connector No.	M40
Connector Name	WIRE TO WIRE
Connector Color	GRAY

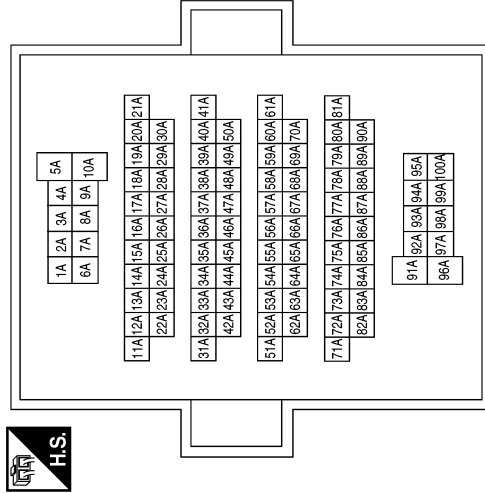

Terminal No.	Color of Wire	Signal Name
89A	L	-
90A	P	-

A  
B  
C  
D  
E  
F  
G  
H  
I  
J  
K  
EXL  
M  
N  
O  
P

# HEADLAMP

< WIRING DIAGRAM >

Connector No.	M81
Connector Name	BCM (BODY CONTROL MODULE)
Connector Color	WHITE

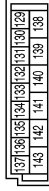

Terminal No.	Color of Wire	Signal Name
131	W	BAT BCM FUSE
134	B	GND 2
139	W	BAT POWER F/L
143	B	GND 1

Connector No.	M43
Connector Name	JOINT CONNECTOR-M17
Connector Color	WHITE



Terminal No.	Color of Wire	Signal Name
1	L	-
2	L	-

Connector No.	M41
Connector Name	JOINT CONNECTOR-M18
Connector Color	WHITE

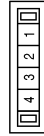

Terminal No.	Color of Wire	Signal Name
1	P	-
2	P	-

Connector No.	E45
Connector Name	JOINT CONNECTOR-E12
Connector Color	BLUE

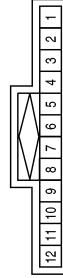

Terminal No.	Color of Wire	Signal Name
1	L	-
4	L	-
7	P	-
10	P	-

Connector No.	M181
Connector Name	JOINT CONNECTOR-M36
Connector Color	WHITE



Terminal No.	Color of Wire	Signal Name
1	W	-
2	W	-

Connector No.	M84
Connector Name	WIRE TO WIRE
Connector Color	WHITE

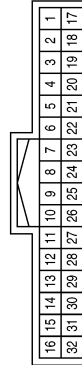

Terminal No.	Color of Wire	Signal Name
17	L	-
18	P	-

ABLIA5040GB



# HEADLAMP

< WIRING DIAGRAM >

Connector No.	E119
Connector Name	IPDM E/R (INTELLIGENT POWER DISTRIBUTION MODULE ENGINE ROOM)
Connector Color	WHITE

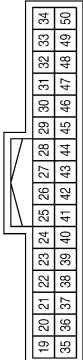
Terminal No.	Color of Wire	Signal Name
28	P	CAN-L
29	L	CAN-H
41	B	GND (SIGNAL)
43	L	IGN SIGNAL

Connector No.	E71
Connector Name	JOINT CONNECTOR-E15
Connector Color	BLACK



Terminal No.	Color of Wire	Signal Name
1	L	-
2	L	-

Connector No.	E70
Connector Name	JOINT CONNECTOR-E14
Connector Color	BLACK





Terminal No.	Color of Wire	Signal Name
1	P	-
2	P	-

Terminal No.	Color of Wire	Signal Name
10G	P	-
35G	P	-
36G	L	-
63G	L	-

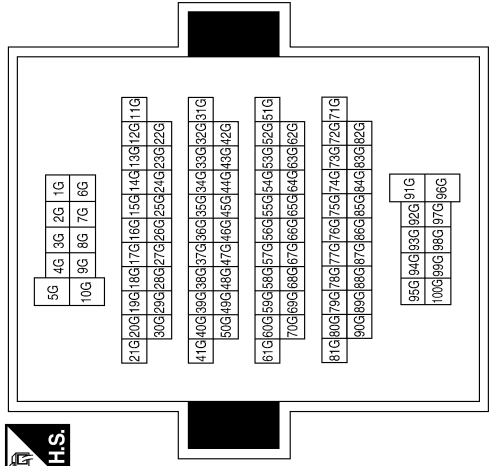
Connector No.	E152
Connector Name	WIRE TO WIRE
Connector Color	WHITE

Connector No.	E121
Connector Name	IPDM E/R (INTELLIGENT POWER DISTRIBUTION MODULE ENGINE ROOM)
Connector Color	WHITE

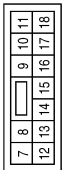
Terminal No.	Color of Wire	Signal Name
7	B	GND (POWER)

AALIA0923GB

A  
B  
C  
D  
E  
F  
G  
H  
I  
J  
K  
EXL  
M  
N  
O  
P

# HEADLAMP

< WIRING DIAGRAM >

Connector No.	E233
Connector Name	FRONT COMBINATION LAMP LH
Connector Color	BLACK



Terminal No.	Color of Wire	Signal Name
3	G	-
4	B	-

Connector No.	E232
Connector Name	FRONT COMBINATION LAMP LH
Connector Color	BLACK



Terminal No.	Color of Wire	Signal Name
1	L	-
2	B	-

Connector No.	E217
Connector Name	IPDM E/R (INTELLIGENT POWER DISTRIBUTION MODULE ENGINE ROOM)
Connector Color	WHITE

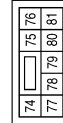

Terminal No.	Color of Wire	Signal Name
75	R	HEADLAMP LO RH
76	L	HEADLAMP LO LH
80	W	HEADLAMP HI RH
81	G	HEADLAMP HI LH

Connector No.	B11
Connector Name	JOINT CONNECTOR-B09
Connector Color	WHITE



Terminal No.	Color of Wire	Signal Name
1	P	-
2	P	-

Connector No.	E238
Connector Name	FRONT COMBINATION LAMP RH
Connector Color	BLACK



Terminal No.	Color of Wire	Signal Name
3	W	-
4	B	-

Connector No.	E237
Connector Name	FRONT COMBINATION LAMP RH
Connector Color	BLACK



Terminal No.	Color of Wire	Signal Name
1	R	-
2	B	-

AALIA0924GB

# HEADLAMP

< WIRING DIAGRAM >

Connector No.	B17
Connector Name	JOINT CONNECTOR-B12
Connector Color	WHITE

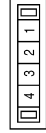

Terminal No.	Color of Wire	Signal Name
1	L	-
2	L	-

Connector No.	B16
Connector Name	JOINT CONNECTOR-B11
Connector Color	WHITE



Terminal No.	Color of Wire	Signal Name
1	P	-
2	P	-

Connector No.	B12
Connector Name	JOINT CONNECTOR-B10
Connector Color	WHITE



Terminal No.	Color of Wire	Signal Name
1	L	-
2	L	-

Connector No.	B69
Connector Name	WIRE TO WIRE
Connector Color	GRAY



Connector No.	B32
Connector Name	WIRE TO WIRE
Connector Color	WHITE

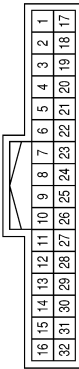

Terminal No.	Color of Wire	Signal Name
18	L	-
19	P	-

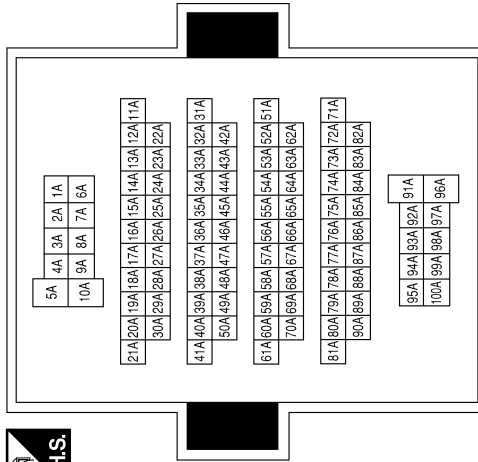

A  
B  
C  
D  
E  
F  
G  
H  
I  
J  
K  
EXL  
M  
N  
O  
P

# HEADLAMP

< WIRING DIAGRAM >

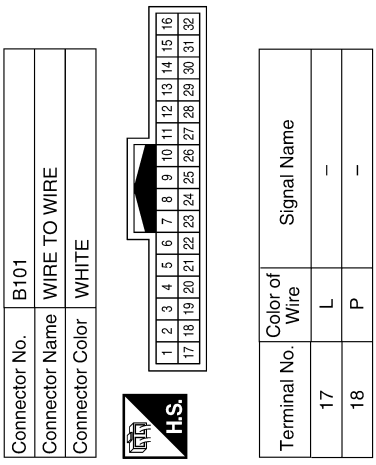
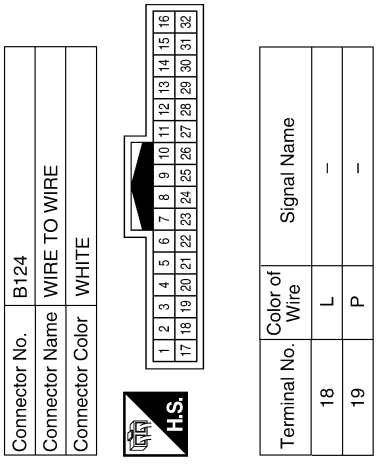

AALIA0926GB

# DAYTIME LIGHT SYSTEM

< WIRING DIAGRAM >

## DAYTIME LIGHT SYSTEM

Wiring Diagram

INFOID:000000009175354

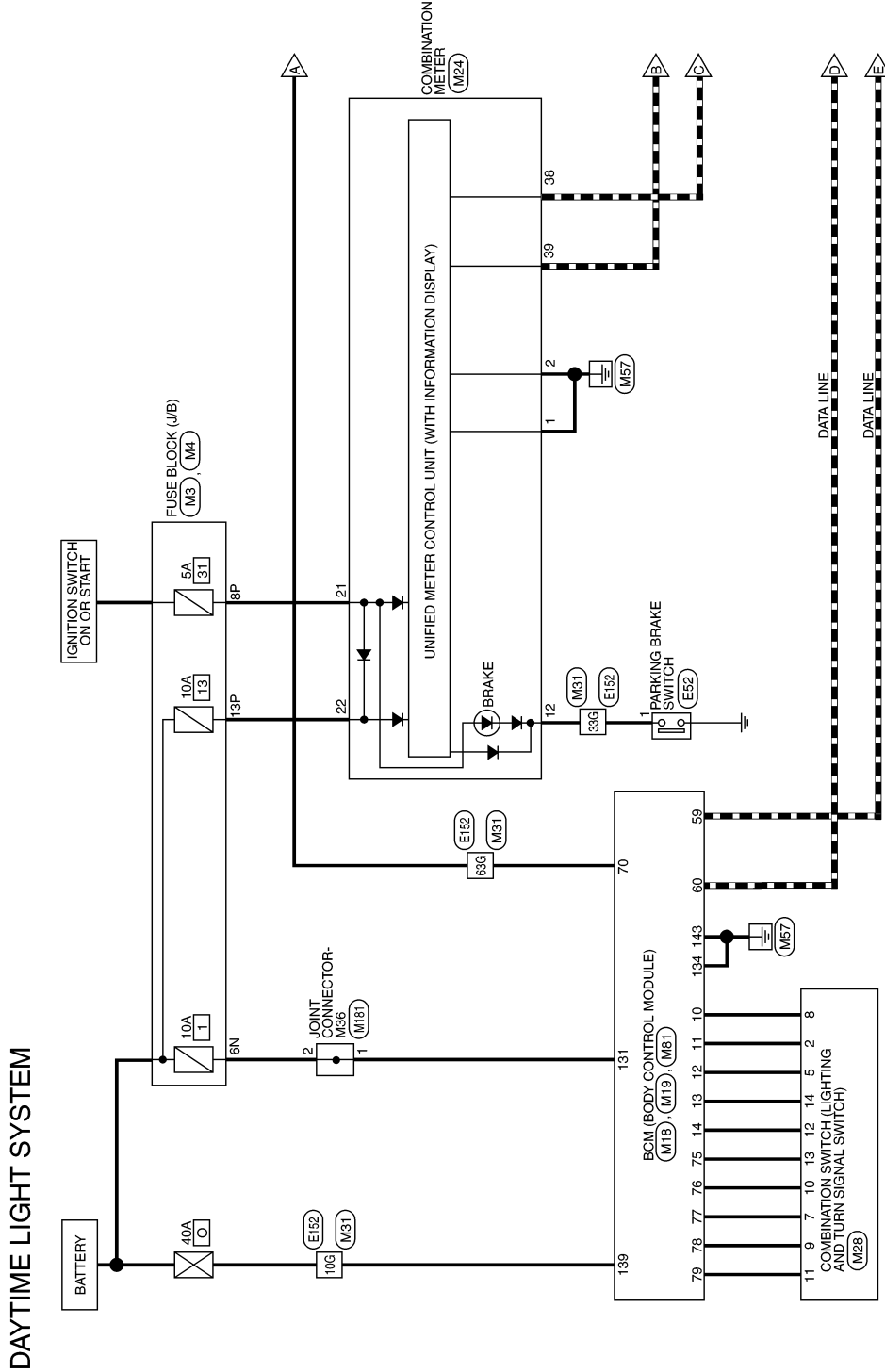

A  
B  
C  
D  
E  
F  
G  
H  
I  
J  
K  
EXL  
M  
N  
O  
P

ABLWA2209GB



# DAYTIME LIGHT SYSTEM

< WIRING DIAGRAM >

## DAYTIME LIGHT SYSTEM CONNECTORS

Connector No.	M3
Connector Name	FUSE BLOCK (J/B)
Connector Color	WHITE

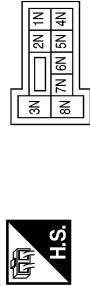

Terminal No.	Color of Wire	Signal Name
6N	W	-

Connector No.	M4
Connector Name	FUSE BLOCK (J/B)
Connector Color	WHITE



Terminal No.	Color of Wire	Signal Name
8P	BG	-
13P	W	-

Connector No.	M18
Connector Name	BCM (BODY CONTROL MODULE)
Connector Color	GREEN



Terminal No.	Color of Wire	Signal Name
10	W	COMBI SW IN 5
11	BG	COMBI SW IN 4
12	R	COMBI SW IN 3
13	G	COMBI SW IN 2
14	P	COMBI SW IN 1

Connector No.	M19
Connector Name	BCM (BODY CONTROL MODULE)
Connector Color	BLACK

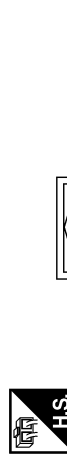

Terminal No.	Color of Wire	Signal Name
59	P	CAN-L
60	L	CAN-H
70	P	IGN USM OUT 1
75	BG	COMBI SW OUT 5
76	P	COMBI SW OUT 4
77	R	COMBI SW OUT 3
78	G	COMBI SW OUT 2
79	W	COMBI SW OUT 1

Connector No.	M24
Connector Name	COMBINATION METER
Connector Color	WHITE

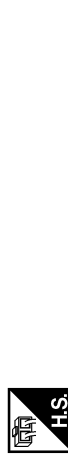

Terminal No.	Color of Wire	Signal Name
1	B	GND1
2	B	GND2
12	G	PKB
21	BG	IGN
22	W	BAT
38	P	CAN-L
39	L	CAN-H

A  
B  
C  
D  
E  
F  
G  
H  
I  
J  
K  
EXL  
M  
N  
O  
P

# DAYTIME LIGHT SYSTEM

< WIRING DIAGRAM >

Connector No.	M28
Connector Name	COMBINATION SWITCH
Connector Color	WHITE

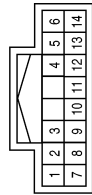

Terminal No.	Color of Wire	Signal Name
2	BG	-
5	R	-
7	R	-
8	W	-
9	G	-
10	P	-
11	W	-
12	P	-
13	BG	-
14	G	-

Connector No.	M31
Connector Name	WIRE TO WIRE
Connector Color	WHITE

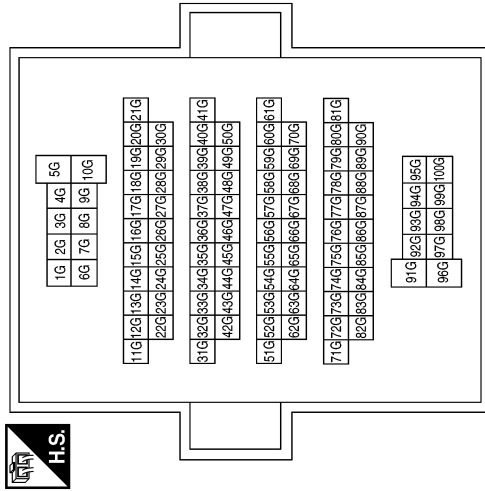

Terminal No.	Color of Wire	Signal Name
10G	W	-
33G	G	-
35G	P	-
36G	L	-
63G	P	-

Connector No.	M40
Connector Name	WIRE TO WIRE
Connector Color	GRAY

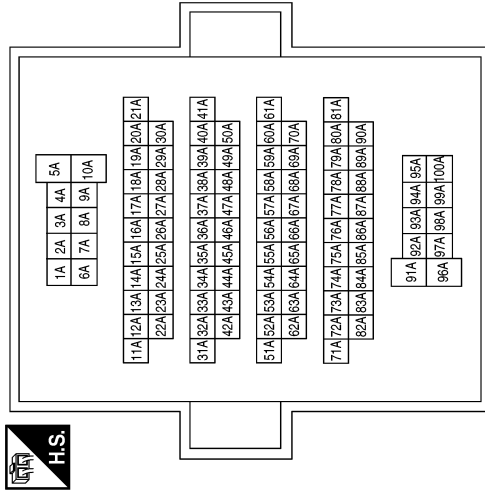

Terminal No.	Color of Wire	Signal Name
89A	L	-
90A	P	-



# DAYTIME LIGHT SYSTEM

< WIRING DIAGRAM >

Connector No.	M81
Connector Name	BCM (BODY CONTROL MODULE)
Connector Color	WHITE

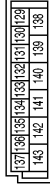

Terminal No.	Color of Wire	Signal Name
131	W	BAT BCM FUSE
134	B	GND 2
139	W	BAT POWER F/L
143	B	GND 1

Connector No.	M43
Connector Name	JOINT CONNECTOR-M17
Connector Color	WHITE

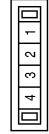

Terminal No.	Color of Wire	Signal Name
1	L	-
2	L	-

Connector No.	M41
Connector Name	JOINT CONNECTOR-M18
Connector Color	WHITE



Terminal No.	Color of Wire	Signal Name
1	P	-
2	P	-

Connector No.	E4
Connector Name	DAYTIME LIGHT RELAY
Connector Color	BROWN



Terminal No.	Color of Wire	Signal Name
1	Y	-
2	LG	-
3	BR	-
5	V	-
6	SB	-
7	V	-

Connector No.	M181
Connector Name	JOINT CONNECTOR-M36
Connector Color	WHITE



Terminal No.	Color of Wire	Signal Name
1	W	-
2	W	-

Connector No.	M84
Connector Name	WIRE TO WIRE
Connector Color	WHITE

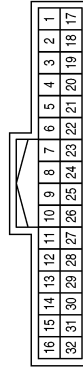

Terminal No.	Color of Wire	Signal Name
17	L	-
18	P	-

ABLIA5033GB

A  
B  
C  
D  
E  
F  
G  
H  
I  
J  
K  
EXL  
M  
N  
O  
P

# DAYTIME LIGHT SYSTEM

< WIRING DIAGRAM >

Connector No.	E45
Connector Name	JOINT CONNECTOR-E12
Connector Color	BLUE

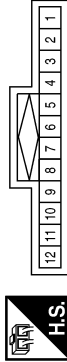

Terminal No.	Color of Wire	Signal Name
1	L	-
4	L	-
7	P	-
10	P	-

Connector No.	E44
Connector Name	JOINT CONNECTOR-E01
Connector Color	WHITE

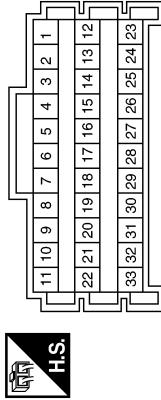

Terminal No.	Color of Wire	Signal Name
30	LG	-
31	LG	-
32	V	-
33	V	-

Connector No.	E5
Connector Name	WIRE TO WIRE
Connector Color	WHITE

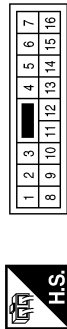

Terminal No.	Color of Wire	Signal Name
1	Y	-
2	SB	-
3	BR	-

Connector No.	E71
Connector Name	JOINT CONNECTOR-E15
Connector Color	BLACK



Terminal No.	Color of Wire	Signal Name
1	L	-
2	L	-

Connector No.	E70
Connector Name	JOINT CONNECTOR-E14
Connector Color	BLACK



Terminal No.	Color of Wire	Signal Name
1	P	-
2	P	-

Connector No.	E52
Connector Name	PARKING BRAKE SWITCH
Connector Color	BLACK



Terminal No.	Color of Wire	Signal Name
1	LG	-

ABLIA5034GB

# DAYTIME LIGHT SYSTEM

< WIRING DIAGRAM >

Connector No.	E121
Connector Name	IPDM E/R (INTELLIGENT POWER DISTRIBUTION MODULE ENGINE ROOM)
Connector Color	WHITE

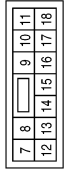

Terminal No.	Color of Wire	Signal Name
7	B	GND (POWER)
14	LG	DTRL

Connector No.	E119
Connector Name	IPDM E/R (INTELLIGENT POWER DISTRIBUTION MODULE ENGINE ROOM)
Connector Color	WHITE

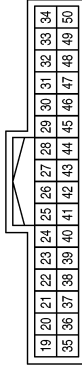

Terminal No.	Color of Wire	Signal Name
28	P	CAN-L
29	L	CAN-H
41	B	GND (SIGNAL)
43	L	IGN SIGNAL

Connector No.	E207
Connector Name	WIRE TO WIRE
Connector Color	WHITE

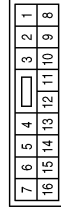

Terminal No.	Color of Wire	Signal Name
1	P	-
2	P	-
3	R	-

Terminal No.	Color of Wire	Signal Name
10G	P	-
33G	LG	-
35G	P	-
36G	L	-
63G	L	-

Connector No.	E152
Connector Name	WIRE TO WIRE
Connector Color	WHITE

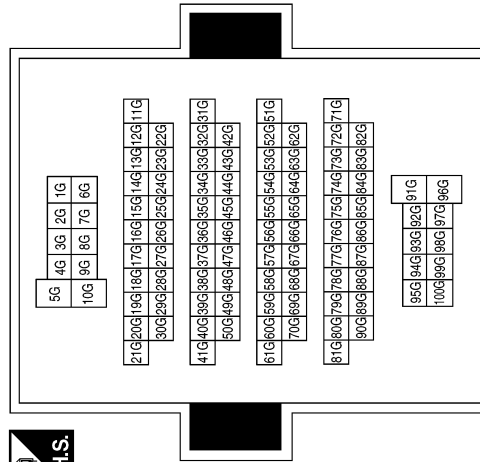

ABLIA5035GB

A  
B  
C  
D  
E  
F  
G  
H  
I  
J  
K  
EXL  
M  
N  
O  
P

# DAYTIME LIGHT SYSTEM

< WIRING DIAGRAM >

Connector No.	E217
Connector Name	IPDM E/R (INTELLIGENT POWER DISTRIBUTION MODULE ENGINE ROOM)
Connector Color	WHITE

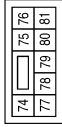

Terminal No.	Color of Wire	Signal Name
75	R	HEADLAMP LO RH
76	L	HEADLAMP LO LH
80	W	HEADLAMP HI RH
81	G	HEADLAMP HI LH

Connector No.	E212
Connector Name	WIRE TO WIRE
Connector Color	GRAY



Terminal No.	Color of Wire	Signal Name
1	P	-
3	B	-

Connector No.	E211
Connector Name	WIRE TO WIRE
Connector Color	GRAY



Terminal No.	Color of Wire	Signal Name
1	R	-
3	B	-

Connector No.	E233
Connector Name	FRONT COMBINATION LAMP LH
Connector Color	BLACK



Terminal No.	Color of Wire	Signal Name
3	G	-
4	B	-

Connector No.	E232
Connector Name	FRONT COMBINATION LAMP LH
Connector Color	BLACK



Terminal No.	Color of Wire	Signal Name
1	L	-
2	B	-

Connector No.	E218
Connector Name	IPDM E/R (INTELLIGENT POWER DISTRIBUTION MODULE ENGINE ROOM)
Connector Color	WHITE

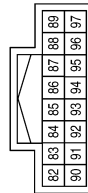

Terminal No.	Color of Wire	Signal Name
85	P	DTRL RLY

AALIA0909GB

# DAYTIME LIGHT SYSTEM

< WIRING DIAGRAM >

Connector No.	E301
Connector Name	WIRE TO WIRE
Connector Color	GRAY



Terminal No.	Color of Wire	Signal Name
1	LG	-
3	B	-

Connector No.	E238
Connector Name	FRONT COMBINATION LAMP RH
Connector Color	BLACK



Terminal No.	Color of Wire	Signal Name
3	W	-
4	B	-

Connector No.	E237
Connector Name	FRONT COMBINATION LAMP RH
Connector Color	BLACK



Terminal No.	Color of Wire	Signal Name
1	R	-
2	B	-

Connector No.	E304
Connector Name	FRONT FOG LAMP RH (WITH DAYTIME LIGHT SYSTEM)
Connector Color	GRAY



Terminal No.	Color of Wire	Signal Name
3	LG	-
4	B	-

Connector No.	E303
Connector Name	FRONT FOG LAMP LH (WITH DAYTIME LIGHT SYSTEM)
Connector Color	GRAY



Terminal No.	Color of Wire	Signal Name
3	LG	-
4	B	-

Connector No.	E302
Connector Name	WIRE TO WIRE
Connector Color	GRAY



Terminal No.	Color of Wire	Signal Name
1	LG	-
3	B	-

ABLIA5036GB

A  
B  
C  
D  
E  
F  
G  
H  
I  
J  
K  
EXL  
M  
N  
O  
P

# DAYTIME LIGHT SYSTEM

< WIRING DIAGRAM >

Connector No.	B16
Connector Name	JOINT CONNECTOR-B11
Connector Color	WHITE



4	3	2	1
---	---	---	---

Terminal No.	Color of Wire	Signal Name
1	P	-
2	P	-

Connector No.	B12
Connector Name	JOINT CONNECTOR-B10
Connector Color	WHITE



4	3	2	1
---	---	---	---

Terminal No.	Color of Wire	Signal Name
1	L	-
2	L	-

Connector No.	B11
Connector Name	JOINT CONNECTOR-B09
Connector Color	WHITE



4	3	2	1
---	---	---	---

Terminal No.	Color of Wire	Signal Name
1	P	-
2	P	-

Connector No.	B32
Connector Name	WIRE TO WIRE
Connector Color	WHITE



16	15	14	13	12	11	10	9	8	7	6	5	4	3	2	1
32	31	30	29	28	27	26	25	24	23	22	21	20	19	18	17

Terminal No.	Color of Wire	Signal Name
18	L	-
19	P	-

Connector No.	B17
Connector Name	JOINT CONNECTOR-B12
Connector Color	WHITE



4	3	2	1
---	---	---	---

Terminal No.	Color of Wire	Signal Name
1	L	-
2	L	-

AALIA0911GB

# DAYTIME LIGHT SYSTEM

< WIRING DIAGRAM >

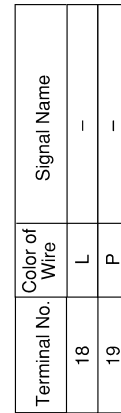
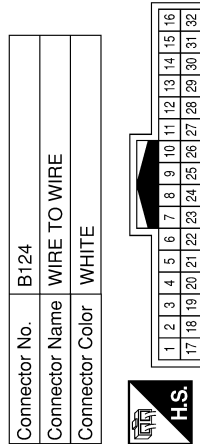
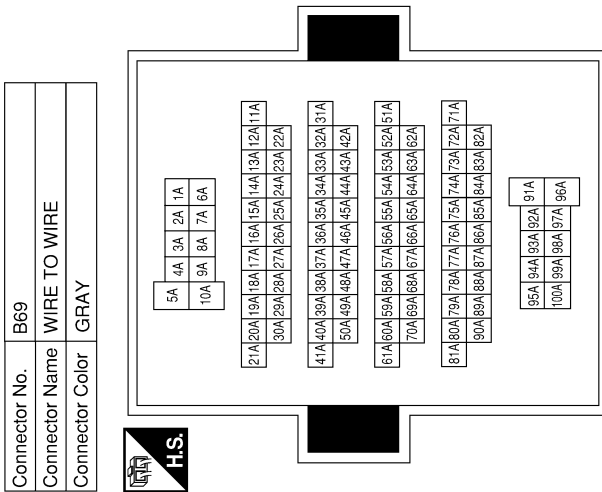
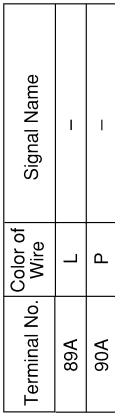
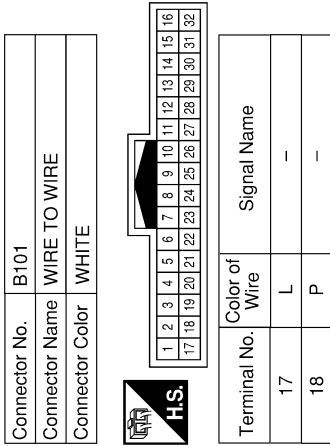

AALIA0912GB

A  
B  
C  
D  
E  
F  
G  
H  
I  
J  
K  
EXL  
M  
N  
O  
P





# AUTO LIGHT SYSTEM

< WIRING DIAGRAM >

## AUTO LIGHT SYSTEM CONNECTORS

Connector No.	M3
Connector Name	FUSE BLOCK (J/B)
Connector Color	WHITE

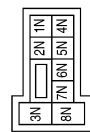

Terminal No.	Color of Wire	Signal Name
6N	W	-

Connector No.	M15
Connector Name	OPTICAL SENSOR
Connector Color	WHITE



Terminal No.	Color of Wire	Signal Name
1	W	-
2	G	-
3	R	-

Connector No.	M18
Connector Name	BCM (BODY CONTROL MODULE)
Connector Color	GREEN

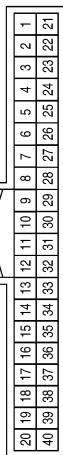

Terminal No.	Color of Wire	Signal Name
3	W	A/L POWER SUPPLY 5V
4	G	A/L SIGNAL
10	W	COMBI SW IN 5
11	BG	COMBI SW IN 4
12	R	COMBI SW IN 3
13	G	COMBI SW IN 2
14	P	COMBI SW IN 1
17	R	GND RF A/L

Connector No.	M19
Connector Name	BCM (BODY CONTROL MODULE)
Connector Color	BLACK



Terminal No.	Color of Wire	Signal Name
59	P	CAN-L
60	L	CAN-H
70	P	IGN USM OUT 1
75	BG	COMBI SW OUT 5
76	P	COMBI SW OUT 4
77	R	COMBI SW OUT 3
78	G	COMBI SW OUT 2
79	W	COMBI SW OUT 1

Connector No.	M20
Connector Name	BCM (BODY CONTROL MODULE)
Connector Color	GRAY

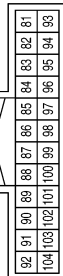

Terminal No.	Color of Wire	Signal Name
82	W	RL DOOR SW
93	R	RR DOOR SW
94	G	AS DOOR SW
96	BG	DR DOOR SW

AALIA0888GB

A B C D E F G H I J K L M N O P

EXL

# AUTO LIGHT SYSTEM

< WIRING DIAGRAM >

Connector No.	M28
Connector Name	COMBINATION SWITCH
Connector Color	WHITE

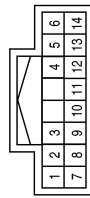

Terminal No.	Color of Wire	Signal Name
2	BG	-
5	R	-
7	R	-
8	W	-
9	G	-
10	P	-
11	W	-
12	P	-
13	BG	-
14	G	-

Connector No.	M31
Connector Name	WIRE TO WIRE
Connector Color	WHITE

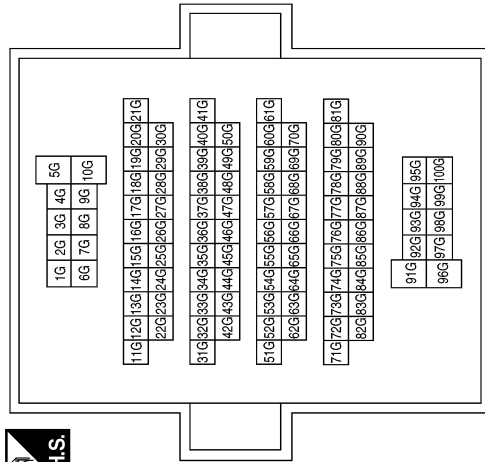

Terminal No.	Color of Wire	Signal Name
10G	W	-
35G	P	-
36G	L	-
63G	P	-

Connector No.	M40
Connector Name	WIRE TO WIRE
Connector Color	GRAY

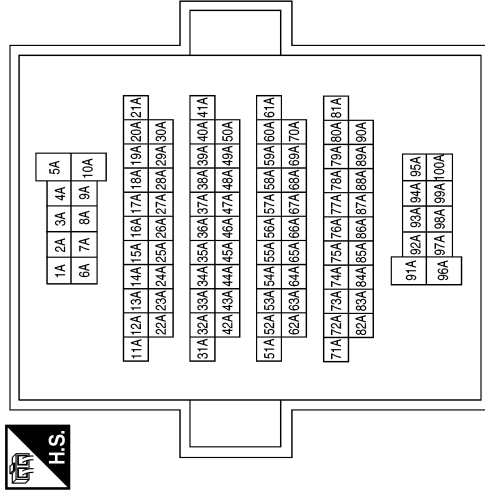

Terminal No.	Color of Wire	Signal Name
65A	W	-
66A	BG	-
89A	L	-
90A	P	-

# AUTO LIGHT SYSTEM

< WIRING DIAGRAM >

Connector No.	M81
Connector Name	BCM (BODY CONTROL MODULE)
Connector Color	WHITE



137	138	139	140	141	142	143	136	135	134	133	132	131	130	129
-----	-----	-----	-----	-----	-----	-----	-----	-----	-----	-----	-----	-----	-----	-----

Terminal No.	Color of Wire	Signal Name
131	W	BAT BCM FUSE
134	B	GND 2
139	W	BAT POWER F/L
143	B	GND 1

Connector No.	M43
Connector Name	JOINT CONNECTOR-M17
Connector Color	WHITE



4	3	2	1
---	---	---	---

Terminal No.	Color of Wire	Signal Name
1	L	-
2	L	-

Connector No.	M41
Connector Name	JOINT CONNECTOR-M18
Connector Color	WHITE



4	3	2	1
---	---	---	---

Terminal No.	Color of Wire	Signal Name
1	P	-
2	P	-

Connector No.	E45
Connector Name	JOINT CONNECTOR-E12
Connector Color	BLUE



12	11	10	9	8	7	6	5	4	3	2	1
----	----	----	---	---	---	---	---	---	---	---	---

Terminal No.	Color of Wire	Signal Name
1	L	-
4	L	-
7	P	-
10	P	-

Connector No.	M181
Connector Name	JOINT CONNECTOR-M36
Connector Color	WHITE



4	3	2	1
---	---	---	---

Terminal No.	Color of Wire	Signal Name
1	W	-
2	W	-

Connector No.	M84
Connector Name	WIRE TO WIRE
Connector Color	WHITE



116	115	114	113	112	111	110	9	8	7	6	5	4	3	2	1
32	31	30	29	28	27	26	25	24	23	22	21	20	19	18	17

Terminal No.	Color of Wire	Signal Name
17	L	-
18	P	-
21	G	-
22	R	-

ABLIA5023GB

A B C D E F G H I J K EXL M N O P

# AUTO LIGHT SYSTEM

< WIRING DIAGRAM >

Connector No.	E119
Connector Name	IPDM E/R (INTELLIGENT POWER DISTRIBUTION MODULE ENGINE ROOM)
Connector Color	WHITE

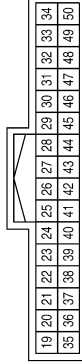

Terminal No.	Color of Wire	Signal Name
28	P	CAN-L
29	L	CAN-H
41	B	GND (SIGNAL)
43	L	IGN SIGNAL

Connector No.	E71
Connector Name	JOINT CONNECTOR-E15
Connector Color	BLACK



Terminal No.	Color of Wire	Signal Name
1	L	-
2	L	-

Connector No.	E70
Connector Name	JOINT CONNECTOR-E14
Connector Color	BLACK



Terminal No.	Color of Wire	Signal Name
1	P	-
2	P	-

Terminal No.	Color of Wire	Signal Name
10G	P	-
35G	P	-
36G	L	-
63G	L	-

Connector No.	E152
Connector Name	WIRE TO WIRE
Connector Color	WHITE

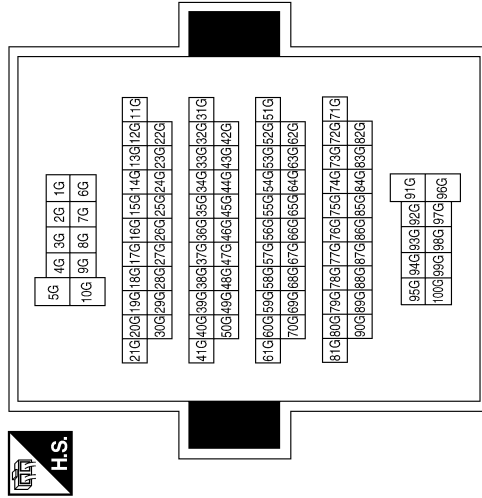

Connector No.	E121
Connector Name	IPDM E/R (INTELLIGENT POWER DISTRIBUTION MODULE ENGINE ROOM)
Connector Color	WHITE

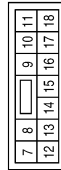

Terminal No.	Color of Wire	Signal Name
7	B	GND (POWER)
9	G	TAIL RH
10	L	TAIL LH

AALIA0891GB

# AUTO LIGHT SYSTEM

< WIRING DIAGRAM >

Connector No.	B8
Connector Name	FRONT DOOR SWITCH LH
Connector Color	WHITE



Terminal No.	Color of Wire	Signal Name
3	L	-

Connector No.	E218
Connector Name	IPDM E/R (INTELLIGENT POWER DISTRIBUTION MODULE ENGINE ROOM)
Connector Color	WHITE

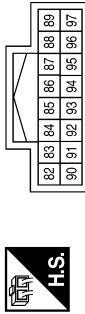

Terminal No.	Color of Wire	Signal Name
90	LG	CLEARANCE

Connector No.	E217
Connector Name	IPDM E/R (INTELLIGENT POWER DISTRIBUTION MODULE ENGINE ROOM)
Connector Color	WHITE

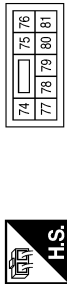

Terminal No.	Color of Wire	Signal Name
75	R	HEADLAMP LO RH
76	L	HEADLAMP LO LH
80	W	HEADLAMP HI RH
81	G	HEADLAMP HI LH

Connector No.	B16
Connector Name	JOINT CONNECTOR-B11
Connector Color	WHITE



Terminal No.	Color of Wire	Signal Name
1	P	-
2	P	-

Connector No.	B12
Connector Name	JOINT CONNECTOR-B10
Connector Color	WHITE



Terminal No.	Color of Wire	Signal Name
1	L	-
2	L	-

Connector No.	B11
Connector Name	JOINT CONNECTOR-B09
Connector Color	WHITE



Terminal No.	Color of Wire	Signal Name
1	P	-
2	P	-

A  
B  
C  
D  
E  
F  
G  
H  
I  
J  
K  
EXL  
M  
N  
O  
P

# AUTO LIGHT SYSTEM

< WIRING DIAGRAM >

Connector No.	B32	
Connector Name	WIRE TO WIRE	
Connector Color	WHITE	

Terminal No.	Color of Wire	Signal Name
18	L	-
19	P	-

Connector No.	B18	
Connector Name	REAR DOOR SWITCH LH	
Connector Color	WHITE	

Terminal No.	Color of Wire	Signal Name
3	SB	-

Connector No.	B17	
Connector Name	JOINT CONNECTOR-B12	
Connector Color	WHITE	

Terminal No.	Color of Wire	Signal Name
1	L	-
2	L	-

Connector No.	B101	
Connector Name	WIRE TO WIRE	
Connector Color	WHITE	

Terminal No.	Color of Wire	Signal Name
65A	SB	-
66A	L	-
89A	L	-
90A	P	-

Connector No.	B69	
Connector Name	WIRE TO WIRE	
Connector Color	GRAY	

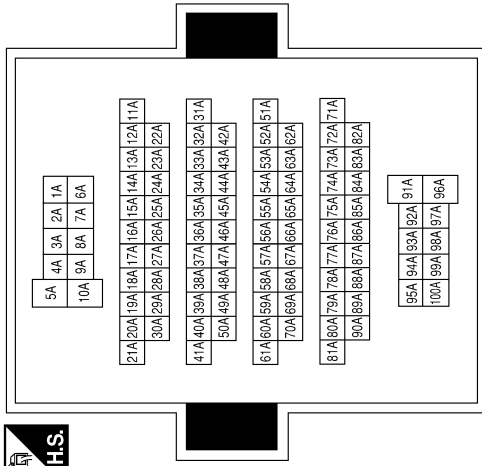

AALIA0893GB

# AUTO LIGHT SYSTEM

< WIRING DIAGRAM >

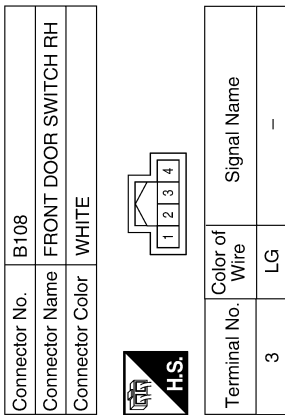
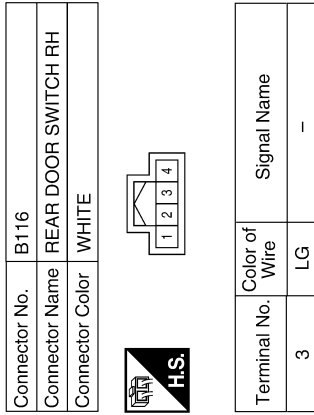
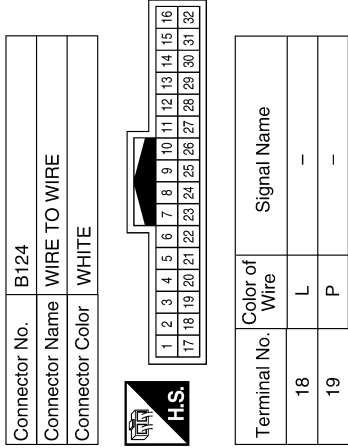

A  
B  
C  
D  
E  
F  
G  
H  
I  
J  
K  
EXL  
M  
N  
O  
P

AALIA0894GB

# FRONT FOG LAMP SYSTEM

< WIRING DIAGRAM >

## FRONT FOG LAMP SYSTEM

### Wiring Diagram

INFOID:000000009175356

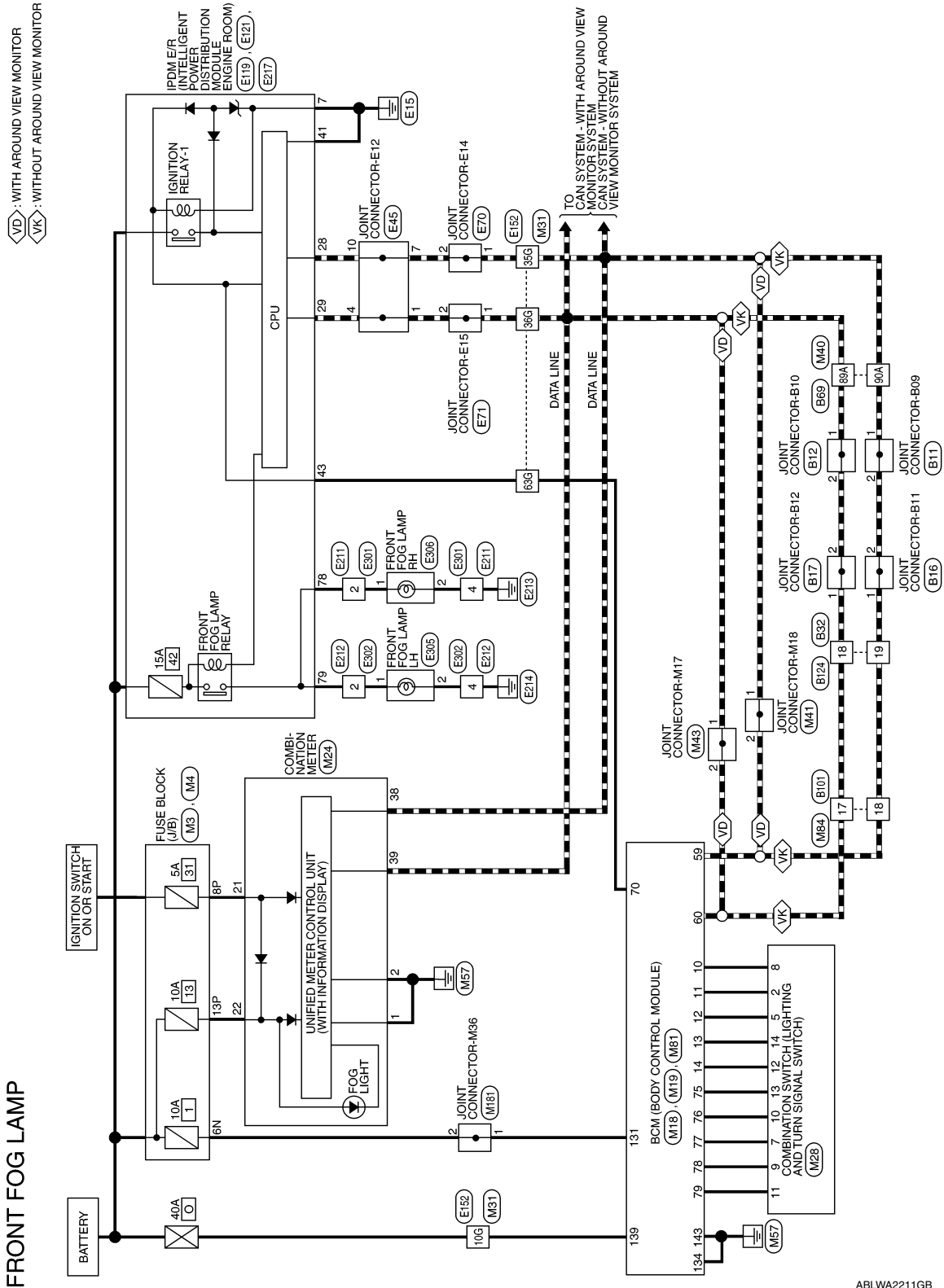

ABLWA2211GB



# FRONT FOG LAMP SYSTEM

< WIRING DIAGRAM >

## FRONT FOG LAMP CONNECTORS

Connector No.	M3
Connector Name	FUSE BLOCK (J/B)
Connector Color	WHITE

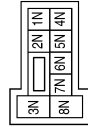

Terminal No.	Color of Wire	Signal Name
6N	W	-

Connector No.	M4
Connector Name	FUSE BLOCK (J/B)
Connector Color	WHITE



Terminal No.	Color of Wire	Signal Name
8P	BG	-
13P	W	-

Connector No.	M18
Connector Name	BCM (BODY CONTROL MODULE)
Connector Color	GREEN

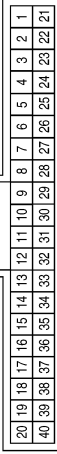

Terminal No.	Color of Wire	Signal Name
10	W	COMBI SW IN 5
11	BG	COMBI SW IN 4
12	R	COMBI SW IN 3
13	G	COMBI SW IN 2
14	P	COMBI SW IN 1

Connector No.	M19
Connector Name	BCM (BODY CONTROL MODULE)
Connector Color	BLACK

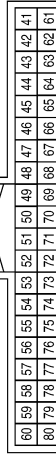

Terminal No.	Color of Wire	Signal Name
59	P	CAN-L
60	L	CAN-H
70	P	IGN USM OUT 1
75	BG	COMBI SW OUT 5
76	P	COMBI SW OUT 4
77	R	COMBI SW OUT 3
78	G	COMBI SW OUT 2
79	W	COMBI SW OUT 1

Connector No.	M24
Connector Name	COMBINATION METER
Connector Color	WHITE

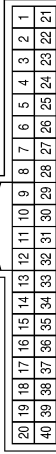

Terminal No.	Color of Wire	Signal Name
1	B	GND1
2	B	GND2
21	BG	IGN
22	W	BAT
38	P	CAN-L
39	L	CAN-H

A  
B  
C  
D  
E  
F  
G  
H  
I  
J  
K  
EXL  
M  
N  
O  
P

# FRONT FOG LAMP SYSTEM

< WIRING DIAGRAM >

Connector No.	M28
Connector Name	COMBINATION SWITCH
Connector Color	WHITE

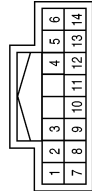

Terminal No.	Color of Wire	Signal Name
2	BG	-
5	R	-
7	R	-
8	W	-
9	G	-
10	P	-
11	W	-
12	P	-
13	BG	-
14	G	-

Connector No.	M31
Connector Name	WIRE TO WIRE
Connector Color	WHITE

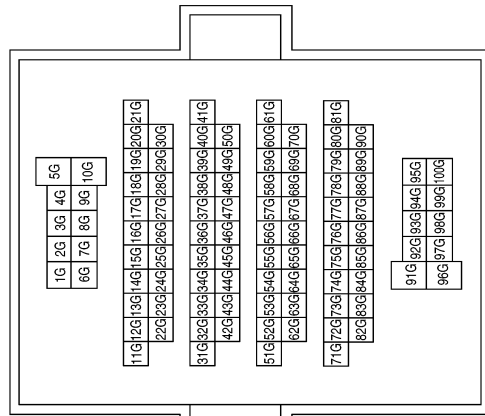

Terminal No.	Color of Wire	Signal Name
10G	W	-
35G	P	-
36G	L	-
63G	P	-

Connector No.	M40
Connector Name	WIRE TO WIRE
Connector Color	GRAY

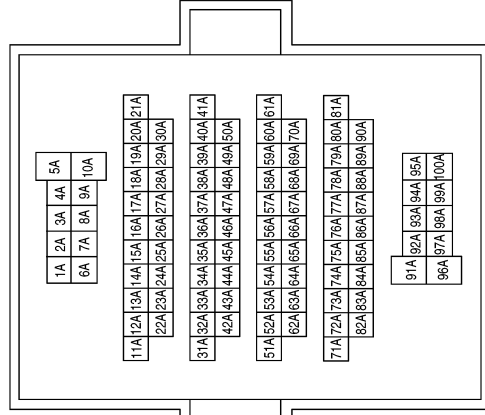

Terminal No.	Color of Wire	Signal Name
89A	L	-
90A	P	-

# FRONT FOG LAMP SYSTEM

< WIRING DIAGRAM >

Connector No.	M81
Connector Name	BCM (BODY CONTROL MODULE)
Connector Color	WHITE

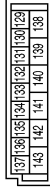

Terminal No.	Color of Wire	Signal Name
131	W	BAT BCM FUSE
134	B	GND 2
139	W	BAT POWER F/L
143	B	GND 1

Connector No.	M43
Connector Name	JOINT CONNECTOR-M17
Connector Color	WHITE



Terminal No.	Color of Wire	Signal Name
1	L	-
2	L	-

Connector No.	M41
Connector Name	JOINT CONNECTOR-M18
Connector Color	WHITE



Terminal No.	Color of Wire	Signal Name
1	P	-
2	P	-

Connector No.	E45
Connector Name	JOINT CONNECTOR-E12
Connector Color	BLUE

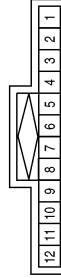

Terminal No.	Color of Wire	Signal Name
1	L	-
4	L	-
7	P	-
10	P	-

Connector No.	M181
Connector Name	JOINT CONNECTOR-M36
Connector Color	WHITE



Terminal No.	Color of Wire	Signal Name
1	W	-
2	W	-

Connector No.	M84
Connector Name	WIRE TO WIRE
Connector Color	WHITE

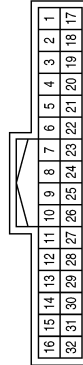

Terminal No.	Color of Wire	Signal Name
17	L	-
18	P	-

ABLIA5038GB

A  
B  
C  
D  
E  
F  
G  
H  
I  
J  
K  
EXL  
M  
N  
O  
P

# FRONT FOG LAMP SYSTEM

< WIRING DIAGRAM >

Connector No.	E119
Connector Name	IPDM E/R (INTELLIGENT POWER DISTRIBUTION MODULE ENGINE ROOM)
Connector Color	WHITE

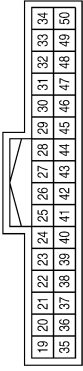
Terminal No.	Color of Wire	Signal Name
28	P	CAN-L
29	L	CAN-H
41	B	GND (SIGNAL)
43	L	IGN SIGNAL

Connector No.	E71
Connector Name	JOINT CONNECTOR-E15
Connector Color	BLACK

Terminal No.	Color of Wire	Signal Name
1	L	-
2	L	-

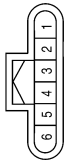
Connector No.	E70
Connector Name	JOINT CONNECTOR-E14
Connector Color	BLACK

Terminal No.	Color of Wire	Signal Name
1	P	-
2	P	-

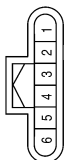
Terminal No.	Color of Wire	Signal Name
10G	P	-
35G	P	-
36G	L	-
63G	L	-

Connector No.	E152
Connector Name	WIRE TO WIRE
Connector Color	WHITE

Connector No.	E121
Connector Name	IPDM E/R (INTELLIGENT POWER DISTRIBUTION MODULE ENGINE ROOM)
Connector Color	WHITE

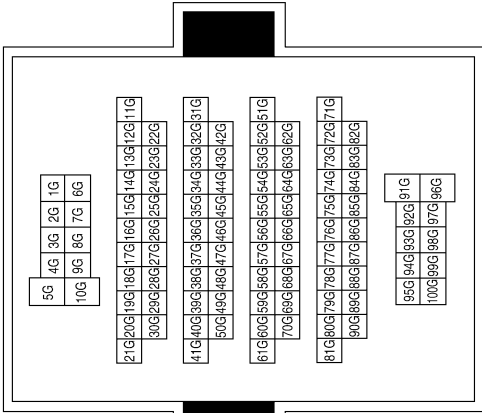
Terminal No.	Color of Wire	Signal Name
7	B	GND (POWER)

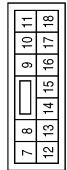
AALIA0916GB

# FRONT FOG LAMP SYSTEM

< WIRING DIAGRAM >

Connector No.	E217
Connector Name	IPDM E/R (INTELLIGENT POWER DISTRIBUTION MODULE ENGINE ROOM)
Connector Color	WHITE

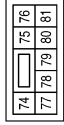

Terminal No.	Color of Wire	Signal Name
78	W	FR FOG LAMP RH
79	L	FR FOG LAMP LH

Connector No.	E212
Connector Name	WIRE TO WIRE
Connector Color	GRAY



Terminal No.	Color of Wire	Signal Name
2	L	-
4	B	-

Connector No.	E211
Connector Name	WIRE TO WIRE
Connector Color	GRAY



Terminal No.	Color of Wire	Signal Name
2	W	-
4	B	-

Connector No.	E305
Connector Name	FRONT FOG LAMP LH
Connector Color	BLACK



Terminal No.	Color of Wire	Signal Name
1	W	-
2	B	-

Connector No.	E302
Connector Name	WIRE TO WIRE
Connector Color	GRAY



Terminal No.	Color of Wire	Signal Name
2	W	-
4	B	-

Connector No.	E301
Connector Name	WIRE TO WIRE
Connector Color	GRAY



Terminal No.	Color of Wire	Signal Name
2	W	-
4	B	-

AALIA0917GB

A  
B  
C  
D  
E  
F  
G  
H  
I  
J  
K  
EXL  
M  
N  
O  
P

# FRONT FOG LAMP SYSTEM

< WIRING DIAGRAM >

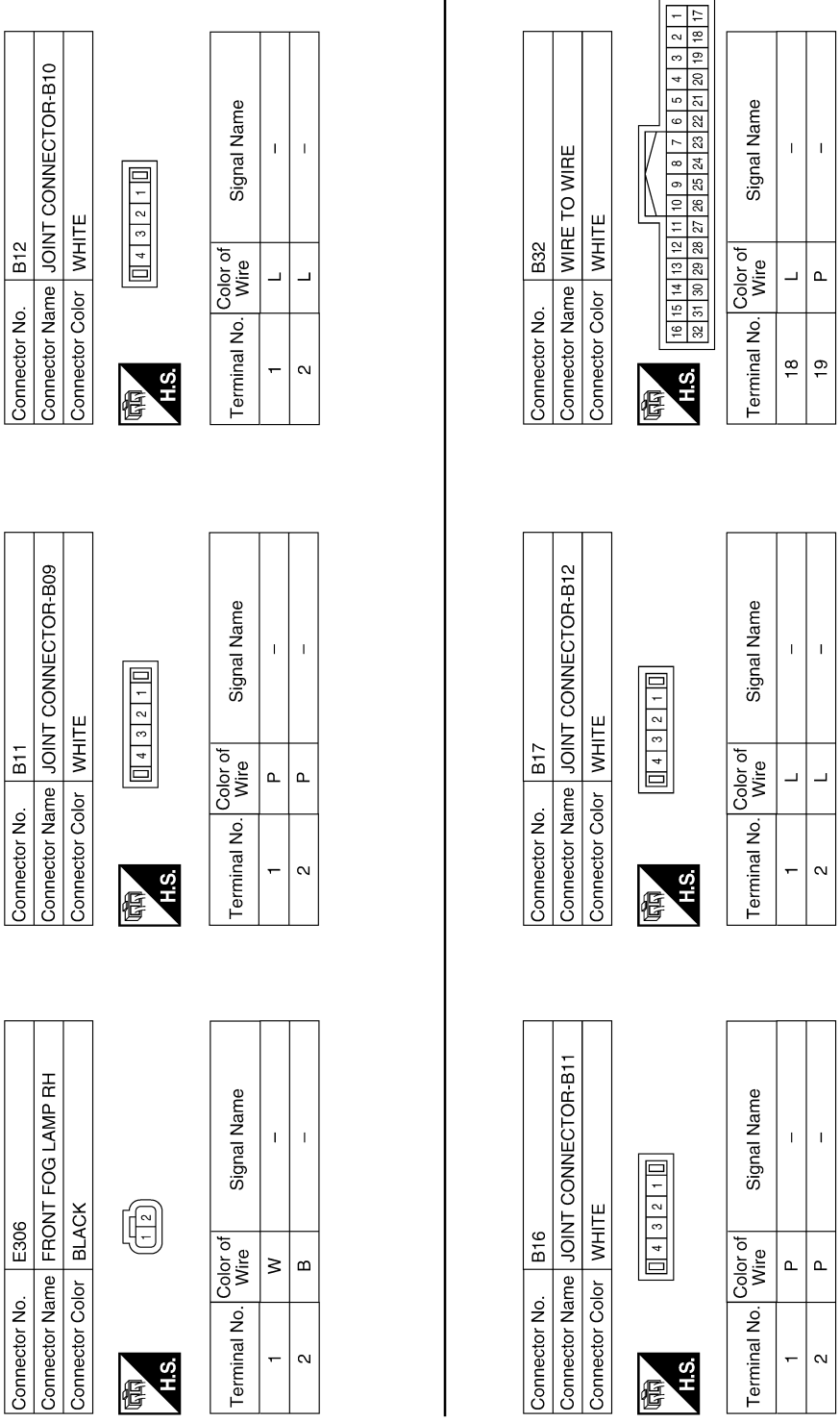

AALIA0918GB

# FRONT FOG LAMP SYSTEM

< WIRING DIAGRAM >

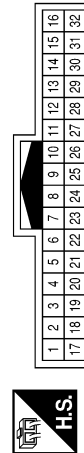
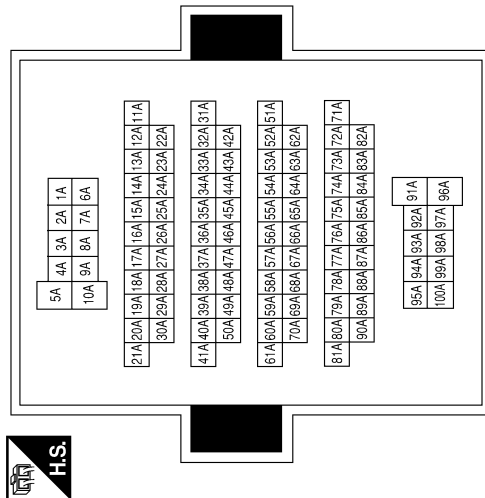
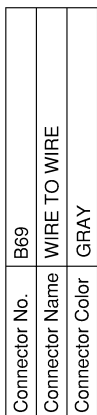
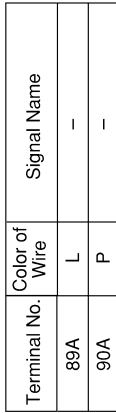
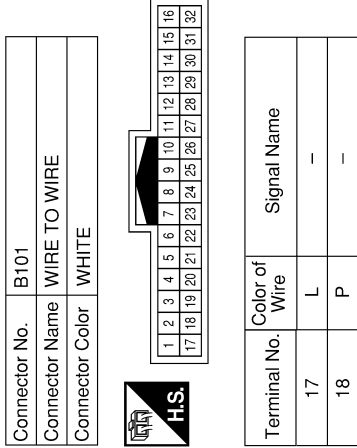

AALIA0919GB

A  
B  
C  
D  
E  
F  
G  
H  
I  
J  
K  
EXL  
M  
N  
O  
P

# TURN SIGNAL AND HAZARD WARNING LAMP SYSTEM

< WIRING DIAGRAM >

## TURN SIGNAL AND HAZARD WARNING LAMP SYSTEM

### Wiring Diagram

INFOID:000000009175357

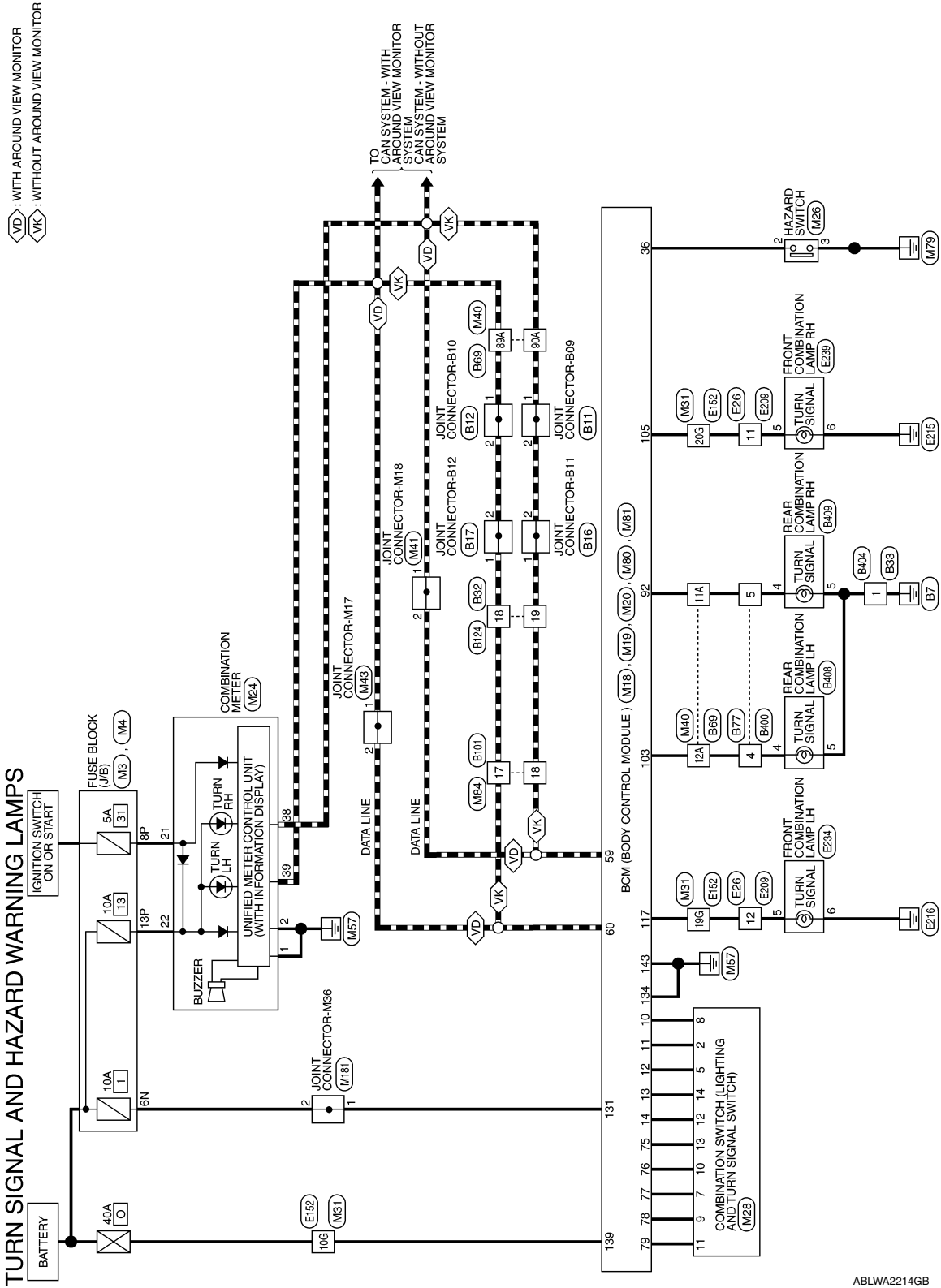

ABLWA2214GB



# TURN SIGNAL AND HAZARD WARNING LAMP SYSTEM

< WIRING DIAGRAM >

## TURN SIGNAL AND HAZARD WARNING LAMPS CONNECTORS

Connector No.	M3
Connector Name	FUSE BLOCK (J/B)
Connector Color	WHITE

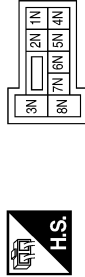

Connector No.	M4
Connector Name	FUSE BLOCK (J/B)
Connector Color	WHITE

Terminal No.	Color of Wire	Signal Name
6N	W	-

Terminal No.	Color of Wire	Signal Name
8P	BG	-
13P	W	-

Connector No.	M18
Connector Name	BCM (BODY CONTROL MODULE)
Connector Color	GREEN

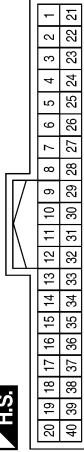

Terminal No.	Color of Wire	Signal Name
10	W	COMBI SW IN 5
11	BG	COMBI SW IN 4
12	R	COMBI SW IN 3
13	G	COMBI SW IN 2
14	P	COMBI SW IN 1
36	W	HAZARD SW

Connector No.	M19
Connector Name	BCM (BODY CONTROL MODULE)
Connector Color	BLACK

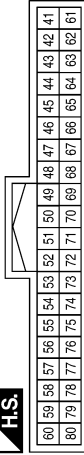

Terminal No.	Color of Wire	Signal Name
59	P	CAN-L
60	L	CAN-H
75	BG	COMBI SW OUT 5
76	P	COMBI SW OUT 4
77	R	COMBI SW OUT 3
78	G	COMBI SW OUT 2
79	W	COMBI SW OUT 1

Connector No.	M20
Connector Name	BCM (BODY CONTROL MODULE)
Connector Color	GRAY

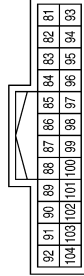

Terminal No.	Color of Wire	Signal Name
92	R	RR FLASHER
103	BG	RL FLASHER

Connector No.	M24
Connector Name	COMBINATION METER
Connector Color	WHITE

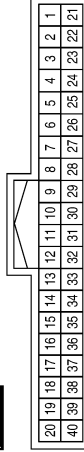

Terminal No.	Color of Wire	Signal Name
1	B	GND1
2	B	GND2
21	BG	IGN
22	W	BAT
38	P	CAN-L
39	L	CAN-H

A  
B  
C  
D  
E  
F  
G  
H  
I  
J  
K  
L  
M  
N  
O  
P

EXL

# TURN SIGNAL AND HAZARD WARNING LAMP SYSTEM

< WIRING DIAGRAM >

Connector No.	M31
Connector Name	WIRE TO WIRE
Connector Color	WHITE

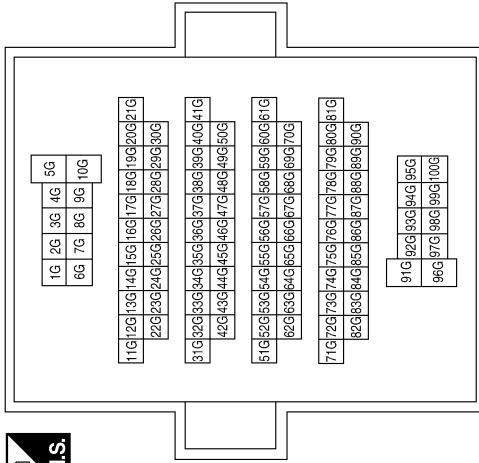

Terminal No.	Color of Wire	Signal Name
10G	W	-
19G	SB	-
20G	LG	-

Connector No.	M28
Connector Name	COMBINATION SWITCH
Connector Color	WHITE

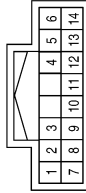

Terminal No.	Color of Wire	Signal Name
2	BG	-
5	R	-
7	R	-
8	W	-
9	G	-
10	P	-
11	W	-
12	P	-
13	BG	-
14	G	-

Connector No.	M26
Connector Name	HAZARD SWITCH
Connector Color	WHITE

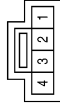

Terminal No.	Color of Wire	Signal Name
2	W	-
3	B	-

AALIA0968GB

# TURN SIGNAL AND HAZARD WARNING LAMP SYSTEM

< WIRING DIAGRAM >

Connector No.	M41
Connector Name	JOINT CONNECTOR-M18
Connector Color	WHITE

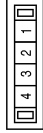

Terminal No.	Color of Wire	Signal Name
1	P	-
2	P	-

Terminal No.	Color of Wire	Signal Name
11A	R	-
12A	BG	-
89A	L	-
90A	P	-

Connector No.	M40
Connector Name	WIRE TO WIRE
Connector Color	GRAY

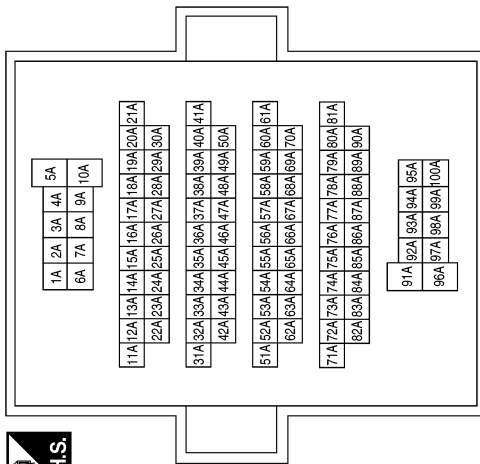

Connector No.	M81
Connector Name	BCM (BODY CONTROL MODULE)
Connector Color	WHITE

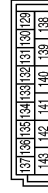

Terminal No.	Color of Wire	Signal Name
131	W	BAT BCM FUSE
134	B	GND 2
139	W	BAT POWER F/L
143	B	GND 1

Connector No.	M80
Connector Name	BCM (BODY CONTROL MODULE)
Connector Color	BLACK



Terminal No.	Color of Wire	Signal Name
105	LG	FR FLASHER
117	SB	FL FLASHER

Connector No.	M43
Connector Name	JOINT CONNECTOR-M17
Connector Color	WHITE

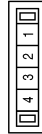

Terminal No.	Color of Wire	Signal Name
1	L	-
2	L	-

ABLIA5048GB

A  
B  
C  
D  
E  
F  
G  
H  
I  
J  
K  
L  
M  
N  
O  
P

EXL

# TURN SIGNAL AND HAZARD WARNING LAMP SYSTEM

< WIRING DIAGRAM >

Connector No.	E26
Connector Name	WIRE TO WIRE
Connector Color	WHITE

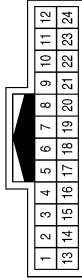

Terminal No.	Color of Wire	Signal Name
11	G	-
12	W	-

Connector No.	M181
Connector Name	JOINT CONNECTOR-M36
Connector Color	WHITE



Terminal No.	Color of Wire	Signal Name
1	W	-
2	W	-

Connector No.	M84
Connector Name	WIRE TO WIRE
Connector Color	WHITE

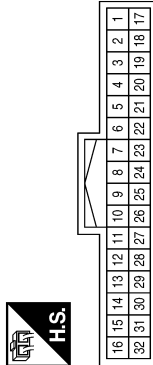

Terminal No.	Color of Wire	Signal Name
17	L	-
18	P	-

Connector No.	E209
Connector Name	WIRE TO WIRE
Connector Color	WHITE

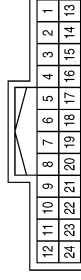

Terminal No.	Color of Wire	Signal Name
11	SB	-
12	Y	-

Terminal No.	Color of Wire	Signal Name
10G	P	-
19G	W	-
20G	G	-

Connector No.	E152
Connector Name	WIRE TO WIRE
Connector Color	WHITE

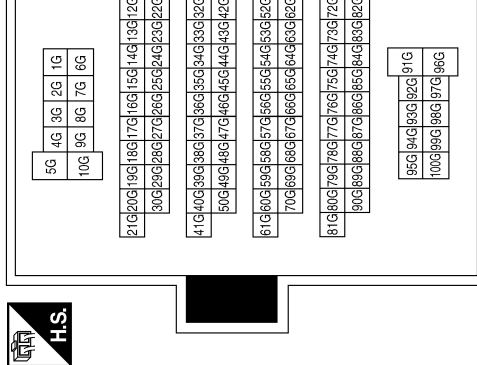

AALIA0970GB

# TURN SIGNAL AND HAZARD WARNING LAMP SYSTEM

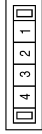

< WIRING DIAGRAM >

Connector No.	B11
Connector Name	JOINT CONNECTOR-B09
Connector Color	WHITE



Terminal No.	Color of Wire	Signal Name
1	P	-
2	P	-

Connector No.	E239
Connector Name	FRONT COMBINATION LAMP RH
Connector Color	GRAY



Terminal No.	Color of Wire	Signal Name
5	SB	-
6	B	-

Connector No.	E234
Connector Name	FRONT COMBINATION LAMP LH
Connector Color	GRAY



Terminal No.	Color of Wire	Signal Name
5	Y	-
6	B	-

Connector No.	B17
Connector Name	JOINT CONNECTOR-B12
Connector Color	WHITE



Terminal No.	Color of Wire	Signal Name
1	L	-
2	L	-

Connector No.	B16
Connector Name	JOINT CONNECTOR-B11
Connector Color	WHITE

Terminal No.	Color of Wire	Signal Name
1	P	-
2	P	-

Connector No.	B12
Connector Name	JOINT CONNECTOR-B10
Connector Color	WHITE

Terminal No.	Color of Wire	Signal Name
1	L	-
2	L	-

AALIA0971GB

A  
B  
C  
D  
E  
F  
G  
H  
I  
J  
K  
EXL  
M  
N  
O  
P

# TURN SIGNAL AND HAZARD WARNING LAMP SYSTEM

< WIRING DIAGRAM >

Connector No.	B33
Connector Name	WIRE TO WIRE
Connector Color	BLACK



Terminal No.	Color of Wire	Signal Name
1	B	-

Connector No.	B32
Connector Name	WIRE TO WIRE
Connector Color	WHITE

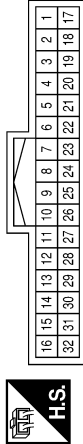

Terminal No.	Color of Wire	Signal Name
18	L	-
19	P	-

Connector No.	B77
Connector Name	WIRE TO WIRE
Connector Color	WHITE



Terminal No.	Color of Wire	Signal Name
4	G	-
5	W	-

Terminal No.	Color of Wire	Signal Name
11A	W	-
12A	G	-
89A	L	-
90A	P	-

Connector No.	B69
Connector Name	WIRE TO WIRE
Connector Color	GRAY

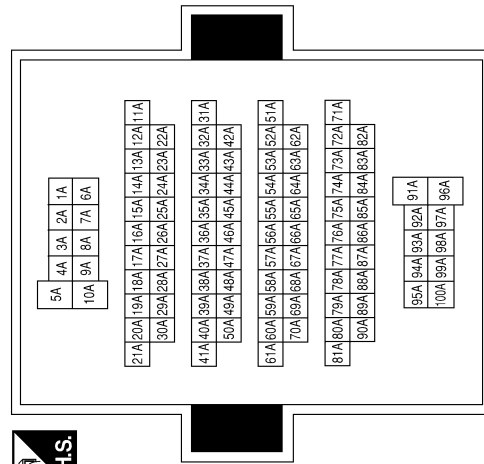

AALIA0972GB

# TURN SIGNAL AND HAZARD WARNING LAMP SYSTEM

< WIRING DIAGRAM >

Connector No.	B400
Connector Name	WIRE TO WIRE
Connector Color	WHITE

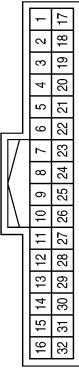
Terminal No.	Color of Wire	Signal Name
4	G	-
5	W	-

Connector No.	B124
Connector Name	WIRE TO WIRE
Connector Color	WHITE

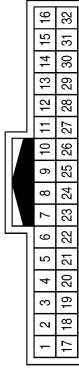

Terminal No.	Color of Wire	Signal Name
18	L	-
19	P	-

Connector No.	B101
Connector Name	WIRE TO WIRE
Connector Color	WHITE

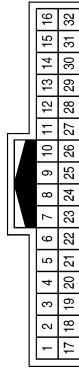

Terminal No.	Color of Wire	Signal Name
17	L	-
18	P	-

Connector No.	B409
Connector Name	REAR COMBINATION LAMP RH
Connector Color	GRAY



Terminal No.	Color of Wire	Signal Name
4	W	-
5	B	-

Connector No.	B408
Connector Name	REAR COMBINATION LAMP LH
Connector Color	GRAY

Terminal No.	Color of Wire	Signal Name
4	G	-
5	B	-

Connector No.	B404
Connector Name	WIRE TO WIRE
Connector Color	BLACK

Terminal No.	Color of Wire	Signal Name
1	B	-

AALIA0973GB

A  
B  
C  
D  
E  
F  
G  
H  
I  
J  
K  
EXL  
M  
N  
O  
P

# PARKING, LICENSE PLATE AND TAIL LAMPS SYSTEM

< WIRING DIAGRAM >

## PARKING, LICENSE PLATE AND TAIL LAMPS SYSTEM

### Wiring Diagram

INFOID:000000009175358

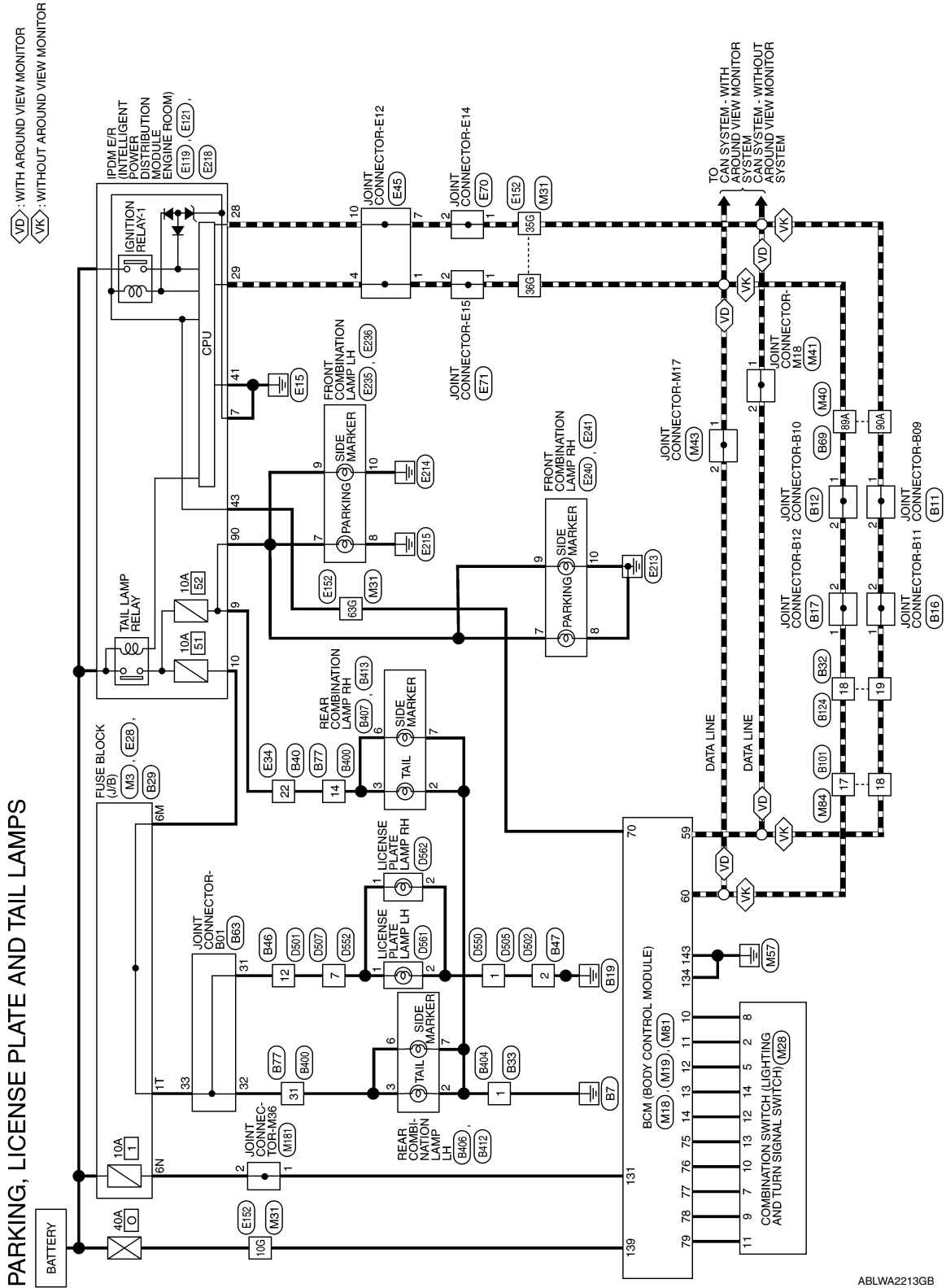

ABLWA2213GB



# PARKING, LICENSE PLATE AND TAIL LAMPS SYSTEM

< WIRING DIAGRAM >

## PARKING, LICENSE PLATE AND TAIL LAMPS CONNECTORS

Connector No.	M3
Connector Name	FUSE BLOCK (J/B)
Connector Color	WHITE

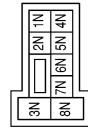

Terminal No.	Color of Wire	Signal Name
6N	W	-

Connector No.	M18
Connector Name	BCM (BODY CONTROL MODULE)
Connector Color	GREEN

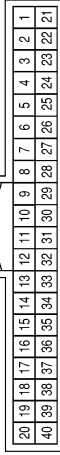

Terminal No.	Color of Wire	Signal Name
10	W	COMBI SW IN 5
11	BG	COMBI SW IN 4
12	R	COMBI SW IN 3
13	G	COMBI SW IN 2
14	P	COMBI SW IN 1

Connector No.	M19
Connector Name	BCM (BODY CONTROL MODULE)
Connector Color	BLACK

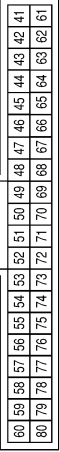

Terminal No.	Color of Wire	Signal Name
59	P	CAN-L
60	L	CAN-H
70	P	IGN USM OUT 1
75	BG	COMBI SW OUT 5
76	P	COMBI SW OUT 4
77	R	COMBI SW OUT 3
78	G	COMBI SW OUT 2
79	W	COMBI SW OUT 1

Connector No.	M28
Connector Name	COMBINATION SWITCH
Connector Color	WHITE

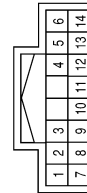

Terminal No.	Color of Wire	Signal Name
2	BG	-
5	R	-
7	R	-
8	W	-
9	G	-
10	P	-
11	W	-
12	P	-
13	BG	-
14	G	-

A  
B  
C  
D  
E  
F  
G  
H  
I  
J  
K  
EXL  
M  
N  
O  
P

# PARKING, LICENSE PLATE AND TAIL LAMPS SYSTEM

< WIRING DIAGRAM >

Connector No.	M41
Connector Name	JOINT CONNECTOR-M18
Connector Color	WHITE



Terminal No.	Color of Wire	Signal Name
1	P	-
2	P	-

Connector No.	M40
Connector Name	WIRE TO WIRE
Connector Color	GRAY

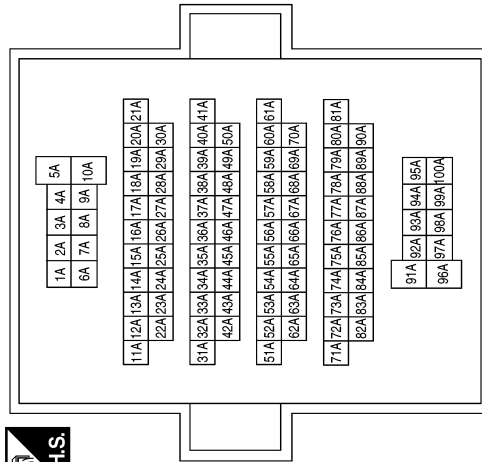

Terminal No.	Color of Wire	Signal Name
89A	L	-
90A	P	-

Connector No.	M31
Connector Name	WIRE TO WIRE
Connector Color	WHITE

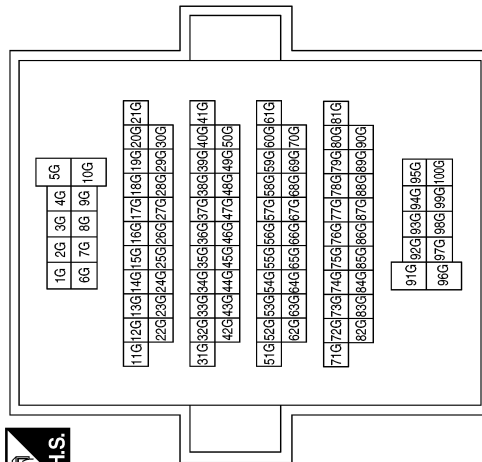

Terminal No.	Color of Wire	Signal Name
10G	W	-
35G	P	-
36G	L	-
63G	P	-

ABLIA5041GB

# PARKING, LICENSE PLATE AND TAIL LAMPS SYSTEM

< WIRING DIAGRAM >

Connector No.	M84
Connector Name	WIRE TO WIRE
Connector Color	WHITE

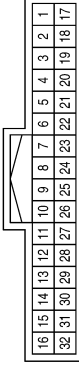
Terminal No.	Color of Wire	Signal Name
17	L	-
18	P	-

Connector No.	M81
Connector Name	BCM (BODY CONTROL MODULE)
Connector Color	WHITE

Terminal No.	Color of Wire	Signal Name
131	W	BAT BCM FUSE
134	B	GND 2
139	W	BAT POWER F/L
143	B	GND 1

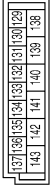
Connector No.	M43
Connector Name	JOINT CONNECTOR-M17
Connector Color	WHITE



Terminal No.	Color of Wire	Signal Name
1	L	-
2	L	-

Connector No.	E34
Connector Name	WIRE TO WIRE
Connector Color	WHITE



Terminal No.	Color of Wire	Signal Name
22	G	-

Connector No.	E28
Connector Name	FUSE BLOCK (J/B)
Connector Color	WHITE



Terminal No.	Color of Wire	Signal Name
6M	L	-

Connector No.	M181
Connector Name	JOINT CONNECTOR-M36
Connector Color	WHITE



Terminal No.	Color of Wire	Signal Name
1	W	-
2	W	-

A  
B  
C  
D  
E  
F  
G  
H  
I  
J  
K  
EXL  
M  
N  
O  
P

# PARKING, LICENSE PLATE AND TAIL LAMPS SYSTEM

< WIRING DIAGRAM >

Connector No.	E71
Connector Name	JOINT CONNECTOR-E15
Connector Color	BLACK



Terminal No.	Color of Wire	Signal Name
1	L	-
2	L	-

Connector No.	E70
Connector Name	JOINT CONNECTOR-E14
Connector Color	BLACK



Terminal No.	Color of Wire	Signal Name
1	P	-
2	P	-

Connector No.	E45
Connector Name	JOINT CONNECTOR-E12
Connector Color	BLUE

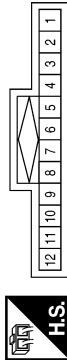

Terminal No.	Color of Wire	Signal Name
1	L	-
4	L	-
7	P	-
10	P	-

Connector No.	E121
Connector Name	IPDM E/R (INTELLIGENT POWER DISTRIBUTION MODULE ENGINE ROOM)
Connector Color	WHITE

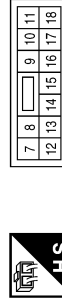

Terminal No.	Color of Wire	Signal Name
7	B	GND (POWER)
9	G	TAIL RH
10	L	TAIL LH

Connector No.	E119
Connector Name	IPDM E/R (INTELLIGENT POWER DISTRIBUTION MODULE ENGINE ROOM)
Connector Color	WHITE

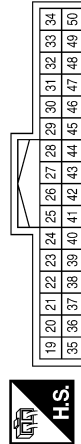

Terminal No.	Color of Wire	Signal Name
28	P	CAN-L
29	L	CAN-H
41	B	GND (SIGNAL)
43	L	IGN SIGNAL

AALIA0930GB

# PARKING, LICENSE PLATE AND TAIL LAMPS SYSTEM

< WIRING DIAGRAM >

Connector No.	E218
Connector Name	IPDM E/R (INTELLIGENT POWER DISTRIBUTION MODULE ENGINE ROOM)
Connector Color	WHITE

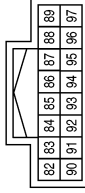

Terminal No.	Color of Wire	Signal Name
90	LG	CLEARANCE

Terminal No.	Color of Wire	Signal Name
10G	P	-
35G	P	-
36G	L	-
63G	L	-

Connector No.	E152
Connector Name	WIRE TO WIRE
Connector Color	WHITE

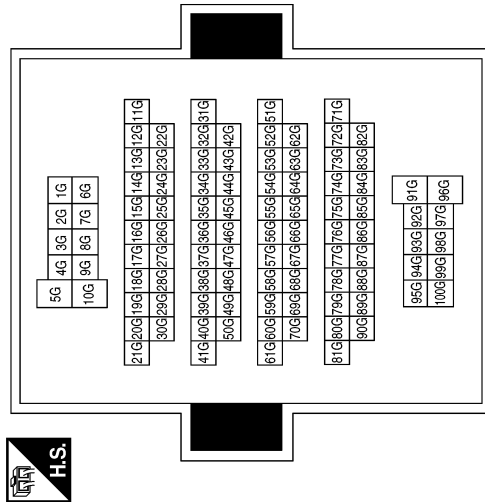

Connector No.	E240
Connector Name	FRONT COMBINATION LAMP RH
Connector Color	GRAY



Terminal No.	Color of Wire	Signal Name
7	LG	-
8	B	-

Connector No.	E236
Connector Name	FRONT COMBINATION LAMP LH
Connector Color	GRAY



Terminal No.	Color of Wire	Signal Name
9	LG	-
10	B	-

Connector No.	E235
Connector Name	FRONT COMBINATION LAMP LH
Connector Color	GRAY



Terminal No.	Color of Wire	Signal Name
7	LG	-
8	B	-

ABLIA5042GB

A  
B  
C  
D  
E  
F  
G  
H  
I  
J  
K  
L  
M  
N  
O  
P

EXL

# PARKING, LICENSE PLATE AND TAIL LAMPS SYSTEM

< WIRING DIAGRAM >

Connector No.	B12
Connector Name	JOINT CONNECTOR-B10
Connector Color	WHITE



Terminal No.	Color of Wire	Signal Name
1	L	-
2	L	-

Connector No.	B11
Connector Name	JOINT CONNECTOR-B09
Connector Color	WHITE

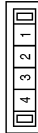

Terminal No.	Color of Wire	Signal Name
1	P	-
2	P	-

Connector No.	E241
Connector Name	FRONT COMBINATION LAMP RH
Connector Color	GRAY



Terminal No.	Color of Wire	Signal Name
9	LG	-
10	B	-

Connector No.	B29
Connector Name	FUSE BLOCK (J/B)
Connector Color	WHITE

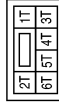

Terminal No.	Color of Wire	Signal Name
1T	W	-

Connector No.	B17
Connector Name	JOINT CONNECTOR-B12
Connector Color	WHITE

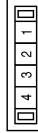

Terminal No.	Color of Wire	Signal Name
1	L	-
2	L	-

Connector No.	B16
Connector Name	JOINT CONNECTOR-B11
Connector Color	WHITE



Terminal No.	Color of Wire	Signal Name
1	P	-
2	P	-

ABLIA5043GB

# PARKING, LICENSE PLATE AND TAIL LAMPS SYSTEM

< WIRING DIAGRAM >

Connector No.	B40
Connector Name	WIRE TO WIRE
Connector Color	WHITE

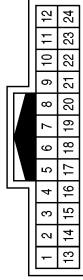

Terminal No.	22	Color of Wire	W	Signal Name	-
--------------	----	---------------	---	-------------	---

Connector No.	B33
Connector Name	WIRE TO WIRE
Connector Color	BLACK



Terminal No.	1	Color of Wire	B	Signal Name	-
--------------	---	---------------	---	-------------	---

Connector No.	B32
Connector Name	WIRE TO WIRE
Connector Color	WHITE

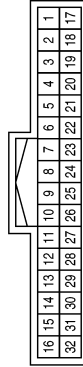

Terminal No.	18	Color of Wire	L	Signal Name	-
	19	Color of Wire	P	Signal Name	-

Connector No.	B63
Connector Name	JOINT CONNECTOR-B01
Connector Color	WHITE

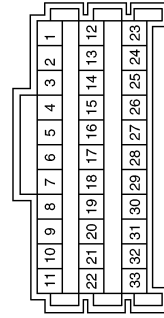

Terminal No.	31	Color of Wire	W	Signal Name	-
	32	Color of Wire	W	Signal Name	-
	33	Color of Wire	W	Signal Name	-

Connector No.	B47
Connector Name	WIRE TO WIRE
Connector Color	GRAY

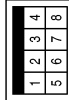

Terminal No.	2	Color of Wire	B	Signal Name	-
--------------	---	---------------	---	-------------	---

Connector No.	B46
Connector Name	WIRE TO WIRE
Connector Color	WHITE

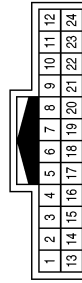

Terminal No.	12	Color of Wire	W	Signal Name	-
--------------	----	---------------	---	-------------	---

ABLIA5044GB

A  
B  
C  
D  
E  
F  
G  
H  
I  
J  
K  
EXL  
M  
N  
O  
P

# PARKING, LICENSE PLATE AND TAIL LAMPS SYSTEM

< WIRING DIAGRAM >

Connector No.	B77
Connector Name	WIRE TO WIRE
Connector Color	WHITE



1	2	3	4	5	6	7	8	9	10	11	12	13	14	15	16
17	18	19	20	21	22	23	24	25	26	27	28	29	30	31	32

Terminal No.	Color of Wire	Signal Name
14	W	-
31	W	-

Terminal No.	Color of Wire	Signal Name
89A	L	-
90A	P	-

Connector No.	B69
Connector Name	WIRE TO WIRE
Connector Color	GRAY

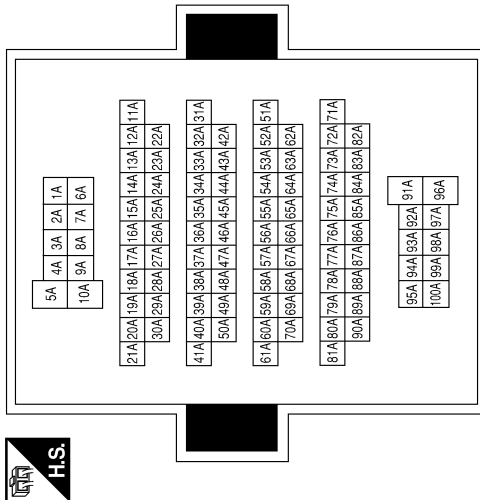

Connector No.	B400
Connector Name	WIRE TO WIRE
Connector Color	WHITE



1	2	3	4	5	6	7	8	9	10	11	12	13	14	15	16
17	18	19	20	21	22	23	24	25	26	27	28	29	30	31	32

Terminal No.	Color of Wire	Signal Name
14	W	-
31	W	-

Connector No.	B124
Connector Name	WIRE TO WIRE
Connector Color	WHITE



1	2	3	4	5	6	7	8	9	10	11	12	13	14	15	16
17	18	19	20	21	22	23	24	25	26	27	28	29	30	31	32

Terminal No.	Color of Wire	Signal Name
18	L	-
19	P	-

Connector No.	B101
Connector Name	WIRE TO WIRE
Connector Color	WHITE



1	2	3	4	5	6	7	8	9	10	11	12	13	14	15	16
17	18	19	20	21	22	23	24	25	26	27	28	29	30	31	32

Terminal No.	Color of Wire	Signal Name
17	L	-
18	P	-



# PARKING, LICENSE PLATE AND TAIL LAMPS SYSTEM

< WIRING DIAGRAM >

Connector No.	B407
Connector Name	REAR COMBINATION LAMP RH
Connector Color	GRAY



Terminal No.	Color of Wire	Signal Name
2	B	-
3	W	-

Connector No.	B406
Connector Name	REAR COMBINATION LAMP LH
Connector Color	GRAY



Terminal No.	Color of Wire	Signal Name
2	B	-
3	W	-

Connector No.	B404
Connector Name	WIRE TO WIRE
Connector Color	BLACK



Terminal No.	Color of Wire	Signal Name
1	B	-

Connector No.	D501
Connector Name	WIRE TO WIRE
Connector Color	WHITE

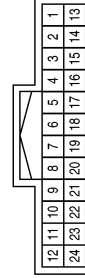

Terminal No.	Color of Wire	Signal Name
12	Y	-

Connector No.	B413
Connector Name	REAR COMBINATION LAMP RH
Connector Color	WHITE



Terminal No.	Color of Wire	Signal Name
6	W	-
7	B	-

Connector No.	B412
Connector Name	REAR COMBINATION LAMP LH
Connector Color	WHITE



Terminal No.	Color of Wire	Signal Name
6	W	-
7	B	-

ABLIA5045GB

A  
B  
C  
D  
E  
F  
G  
H  
I  
J  
K  
EXL  
M  
N  
O  
P

# PARKING, LICENSE PLATE AND TAIL LAMPS SYSTEM

< WIRING DIAGRAM >

Connector No.	D507
Connector Name	WIRE TO WIRE
Connector Color	WHITE

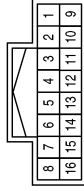

Terminal No.	7	Color of Wire	Y	Signal Name	-
--------------	---	---------------	---	-------------	---

Connector No.	D505
Connector Name	WIRE TO WIRE
Connector Color	WHITE



Terminal No.	1	Color of Wire	B	Signal Name	-
--------------	---	---------------	---	-------------	---

Connector No.	D502
Connector Name	WIRE TO WIRE
Connector Color	GRAY

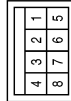

Terminal No.	2	Color of Wire	B	Signal Name	-
--------------	---	---------------	---	-------------	---

Connector No.	D561
Connector Name	LICENSE PLATE LAMP LH
Connector Color	BROWN



Terminal No.	1	Color of Wire	LG	Signal Name	-
2	B				-

Connector No.	D552
Connector Name	WIRE TO WIRE
Connector Color	WHITE



Terminal No.	7	Color of Wire	LG	Signal Name	-
--------------	---	---------------	----	-------------	---

Connector No.	D550
Connector Name	WIRE TO WIRE
Connector Color	WHITE

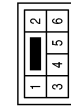

Terminal No.	1	Color of Wire	B	Signal Name	-
--------------	---	---------------	---	-------------	---

ABLIA5046GB

# PARKING, LICENSE PLATE AND TAIL LAMPS SYSTEM

< WIRING DIAGRAM >

A  
B  
C  
D  
E  
F  
G  
H  
I  
J  
K  
EXL  
M  
N  
O  
P

Connector No.	D562
Connector Name	LICENSE PLATE LAMP RH
Connector Color	BROWN



Terminal No.	Color of Wire	Signal Name
1	LG	-
2	B	-

ABLIA5047GB



# STOP LAMP

< WIRING DIAGRAM >

## STOP LAMP CONNECTORS

Connector No.	E28
Connector Name	FUSE BLOCK (J/B)
Connector Color	WHITE

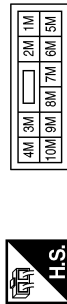

Terminal No.	Color of Wire	Signal Name
5M	Y	-
7M	R	-

Connector No.	E38
Connector Name	STOP LAMP SWITCH
Connector Color	WHITE



Terminal No.	Color of Wire	Signal Name
1	Y	-
2	W	-

Connector No.	E39
Connector Name	STOP LAMP RELAY
Connector Color	BLUE



Terminal No.	Color of Wire	Signal Name
1	W	-
2	B	-
3	Y	-
5	R	-

Connector No.	E44
Connector Name	JOINT CONNECTOR-E01
Connector Color	WHITE

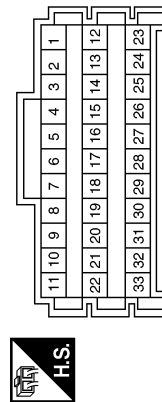

Terminal No.	Color of Wire	Signal Name
12	Y	-
13	Y	-
14	Y	-

Connector No.	B30
Connector Name	FUSE BLOCK (J/B)
Connector Color	WHITE

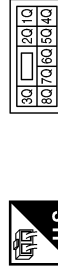

Terminal No.	Color of Wire	Signal Name
5Q	G	-

Connector No.	B33
Connector Name	WIRE TO WIRE
Connector Color	BLACK



Terminal No.	Color of Wire	Signal Name
1	B	-

A  
B  
C  
D  
E  
F  
G  
H  
I  
J  
K  
EXL  
M  
N  
O  
P

# STOP LAMP

< WIRING DIAGRAM >

Connector No.	B77
Connector Name	WIRE TO WIRE
Connector Color	WHITE

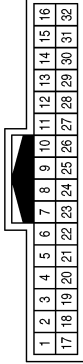
Terminal No.	Color of Wire	Signal Name
15	G	-

Connector No.	B47
Connector Name	WIRE TO WIRE
Connector Color	GRAY

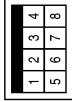

Terminal No.	Color of Wire	Signal Name
2	B	-

Connector No.	B46
Connector Name	WIRE TO WIRE
Connector Color	WHITE

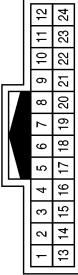

Terminal No.	Color of Wire	Signal Name
24	G	-

Connector No.	B406
Connector Name	REAR COMBINATION LAMP LH
Connector Color	GRAY

Terminal No.	Color of Wire	Signal Name
1	G	-
2	B	-

Connector No.	B404
Connector Name	WIRE TO WIRE
Connector Color	BLACK

Terminal No.	Color of Wire	Signal Name
1	B	-

Connector No.	B400
Connector Name	WIRE TO WIRE
Connector Color	WHITE

Terminal No.	Color of Wire	Signal Name
15	G	-

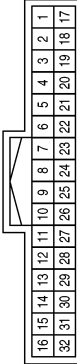
ABLIA5030GB

# STOP LAMP

< WIRING DIAGRAM >

Connector No.	D502
Connector Name	WIRE TO WIRE
Connector Color	GRAY

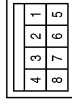

Terminal No.	2	Color of Wire	B	Signal Name	-
--------------	---	---------------	---	-------------	---

Connector No.	D501
Connector Name	WIRE TO WIRE
Connector Color	WHITE

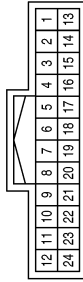

Terminal No.	24	Color of Wire	LG	Signal Name	-
--------------	----	---------------	----	-------------	---

Connector No.	B407
Connector Name	REAR COMBINATION LAMP RH
Connector Color	GRAY



Terminal No.	1	Color of Wire	G	Signal Name	-
Terminal No.	2	Color of Wire	B	Signal Name	-

Connector No.	D503
Connector Name	HIGH-MOUNTED STOP LAMP
Connector Color	BROWN



Terminal No.	1	Color of Wire	LG	Signal Name	-
Terminal No.	2	Color of Wire	B	Signal Name	-

A  
B  
C  
D  
E  
F  
G  
H  
I  
J  
K  
EXL  
M  
N  
O  
P





# BACK-UP LAMP

< WIRING DIAGRAM >

## BACK-UP LAMP CONNECTORS

Connector No.	M3
Connector Name	FUSE BLOCK (J/B)
Connector Color	WHITE

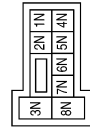

Terminal No.	Color of Wire	Signal Name
6N	W	-

Connector No.	M18
Connector Name	BCM (BODY CONTROL MODULE)
Connector Color	GREEN

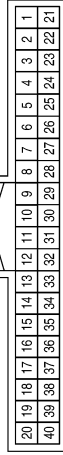

Terminal No.	Color of Wire	Signal Name
20	W	SHIFT P
27	G	BRAKE SW LAMP

Connector No.	M19
Connector Name	BCM (BODY CONTROL MODULE)
Connector Color	BLACK

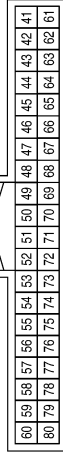

Terminal No.	Color of Wire	Signal Name
59	P	CAN-L
60	L	CAN-H
69	G	AT DEVICE OUT

Connector No.	M20
Connector Name	BCM (BODY CONTROL MODULE)
Connector Color	GRAY

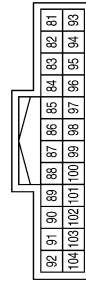

Terminal No.	Color of Wire	Signal Name
104	LG	REVERSE LAMP OUT

Connector No.	M31
Connector Name	WIRE TO WIRE
Connector Color	WHITE

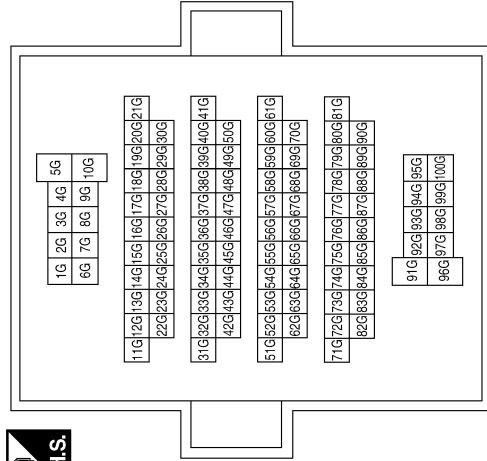

Terminal No.	Color of Wire	Signal Name
10G	W	-
35G	P	-
36G	L	-

A  
B  
C  
D  
E  
F  
G  
H  
I  
J  
K  
L  
M  
N  
O  
P

EXL

# BACK-UP LAMP

< WIRING DIAGRAM >

Connector No.	M41
Connector Name	JOINT CONNECTOR-M18
Connector Color	WHITE

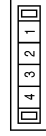

Terminal No.	Color of Wire	Signal Name
1	P	-
2	P	-

Terminal No.	Color of Wire	Signal Name
79A	LG	-
89A	L	-
90A	P	-

Connector No.	M40
Connector Name	WIRE TO WIRE
Connector Color	GRAY

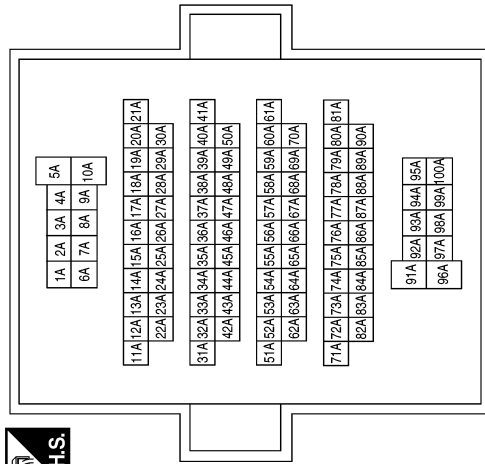

Connector No.	M78
Connector Name	CVT SHIFT SELECTOR
Connector Color	WHITE

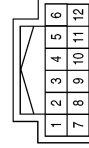

Terminal No.	Color of Wire	Signal Name
3	GR	-
4	B	-
5	G	-
6	W	-

Connector No.	M68
Connector Name	FUSE BLOCK (J/B)
Connector Color	BROWN



Terminal No.	Color of Wire	Signal Name
9R	G	-

Connector No.	M43
Connector Name	JOINT CONNECTOR-M17
Connector Color	WHITE

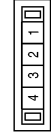

Terminal No.	Color of Wire	Signal Name
1	L	-
2	L	-

ABLIA5024GB

# BACK-UP LAMP

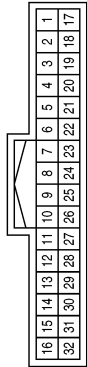

< WIRING DIAGRAM >

Connector No.	M84
Connector Name	WIRE TO WIRE
Connector Color	WHITE

Terminal No.	Color of Wire	Signal Name
17	L	-
18	P	-

Connector No.	M81
Connector Name	BCM (BODY CONTROL MODULE)
Connector Color	WHITE



Terminal No.	Color of Wire	Signal Name
131	W	BAT BCM FUSE
134	B	GND 2
139	W	BAT POWER F/L
143	B	GND 1

Connector No.	M80
Connector Name	BCM (BODY CONTROL MODULE)
Connector Color	BLACK

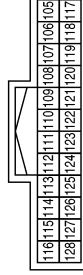
Terminal No.	Color of Wire	Signal Name
108	GR	SHIFT LOCK SOLENOID OUT

Connector No.	E2
Connector Name	WIRE TO WIRE
Connector Color	WHITE

Terminal No.	Color of Wire	Signal Name
9	P	-
10	L	-

Connector No.	M181
Connector Name	JOINT CONNECTOR-M36
Connector Color	WHITE



Terminal No.	Color of Wire	Signal Name
1	W	-
2	W	-

Connector No.	M120
Connector Name	JOINT CONNECTOR-M21
Connector Color	WHITE



Terminal No.	Color of Wire	Signal Name
1	LG	-
2	LG	-

ABLIA5025GB

A  
B  
C  
D  
E  
F  
G  
H  
I  
J  
K  
EXL  
M  
N  
O  
P

# BACK-UP LAMP

< WIRING DIAGRAM >

Connector No.	E38
Connector Name	STOP LAMP RELAY
Connector Color	BLUE



Terminal No.	Color of Wire	Signal Name
1	W	-
2	B	-
3	Y	-
5	R	-

Connector No.	E38
Connector Name	STOP LAMP SWITCH
Connector Color	WHITE



Terminal No.	Color of Wire	Signal Name
1	Y	-
2	W	-

Connector No.	E28
Connector Name	FUSE BLOCK (J/B)
Connector Color	WHITE

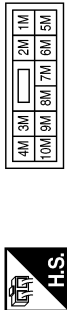

Terminal No.	Color of Wire	Signal Name
5M	Y	-
7M	R	-

Connector No.	E70
Connector Name	JOINT CONNECTOR-E14
Connector Color	BLACK



Terminal No.	Color of Wire	Signal Name
1	P	-
2	P	-

Connector No.	E45
Connector Name	JOINT CONNECTOR-E12
Connector Color	BLUE

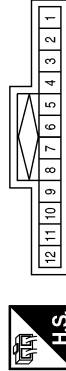

Terminal No.	Color of Wire	Signal Name
1	L	-
3	L	-
7	P	-
9	P	-

Connector No.	E44
Connector Name	JOINT CONNECTOR-E01
Connector Color	WHITE

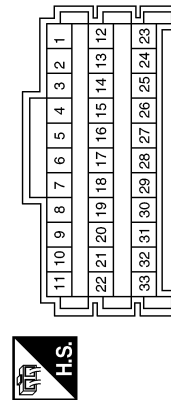

Terminal No.	Color of Wire	Signal Name
12	Y	-
13	Y	-
14	Y	-

ABLIA5026GB

# BACK-UP LAMP

< WIRING DIAGRAM >

Terminal No.	Color of Wire	Signal Name
10G	P	-
35G	P	-
36G	L	-

Connector No.	E152
Connector Name	WIRE TO WIRE
Connector Color	WHITE

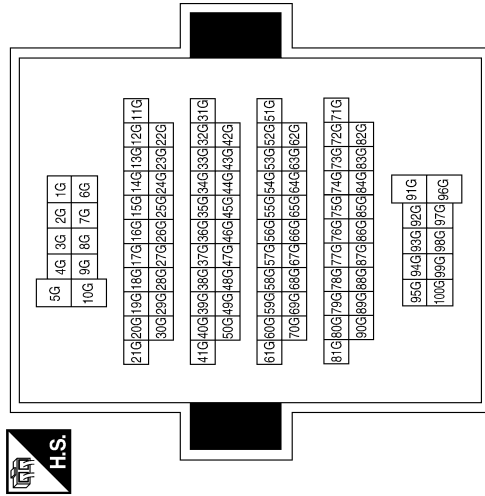

Connector No.	E71
Connector Name	JOINT CONNECTOR-E15
Connector Color	BLACK

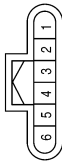

Terminal No.	Color of Wire	Signal Name
1	L	-
2	L	-

Connector No.	F32
Connector Name	WIRE TO WIRE
Connector Color	WHITE

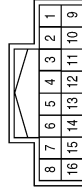

Terminal No.	Color of Wire	Signal Name
9	P	-
10	L	-

Connector No.	F24
Connector Name	IPDM E/R (INTELLIGENT POWER DISTRIBUTION MODULE ENGINE ROOM)
Connector Color	WHITE



Terminal No.	Color of Wire	Signal Name
64	LG	START IG BGI

Connector No.	F15
Connector Name	TCM (TRANSMISSION CONTROL MODULE)
Connector Color	BLACK

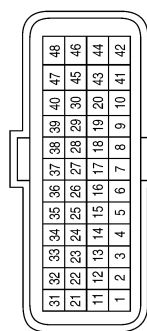

Terminal No.	Color of Wire	Signal Name
6	BR	R RANGE SW
23	P	CAN-L
33	L	CAN-H

AALIA0899GB

A  
B  
C  
D  
E  
F  
G  
H  
I  
J  
K  
EXL  
M  
N  
O  
P

# BACK-UP LAMP

< WIRING DIAGRAM >

Connector No.	B12
Connector Name	JOINT CONNECTOR-B10
Connector Color	WHITE



Terminal No.	Color of Wire	Signal Name
1	L	-
2	L	-

Connector No.	B11
Connector Name	JOINT CONNECTOR-B09
Connector Color	WHITE



Terminal No.	Color of Wire	Signal Name
1	P	-
2	P	-

Connector No.	F36
Connector Name	TRANSMISSION RANGE SWITCH
Connector Color	BLACK

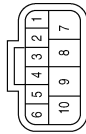

Terminal No.	Color of Wire	Signal Name
4	LG	-
8	BR	-

Connector No.	B32
Connector Name	WIRE TO WIRE
Connector Color	WHITE

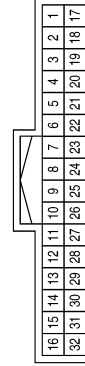

Terminal No.	Color of Wire	Signal Name
18	L	-
19	P	-

Connector No.	B17
Connector Name	JOINT CONNECTOR-B12
Connector Color	WHITE



Terminal No.	Color of Wire	Signal Name
1	L	-
2	L	-

Connector No.	B16
Connector Name	JOINT CONNECTOR-B11
Connector Color	WHITE

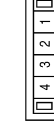

Terminal No.	Color of Wire	Signal Name
1	P	-
2	P	-

AALIA0900GB

# BACK-UP LAMP

< WIRING DIAGRAM >

Connector No.	B63
Connector Name	JOINT CONNECTOR-B01
Connector Color	WHITE

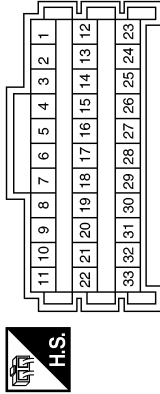

Terminal No.	Color of Wire	Signal Name
9	BR	-
10	BR	-

Connector No.	B47
Connector Name	WIRE TO WIRE
Connector Color	GRAY



Terminal No.	Color of Wire	Signal Name
2	B	-

Connector No.	B46
Connector Name	WIRE TO WIRE
Connector Color	WHITE

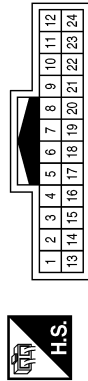

Terminal No.	Color of Wire	Signal Name
22	BR	-

Connector No.	B101
Connector Name	WIRE TO WIRE
Connector Color	WHITE

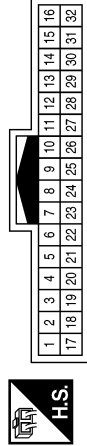

Terminal No.	Color of Wire	Signal Name
17	L	-
18	P	-

Terminal No.	Color of Wire	Signal Name
79A	BR	-
89A	L	-
90A	P	-

Connector No.	B69
Connector Name	WIRE TO WIRE
Connector Color	GRAY

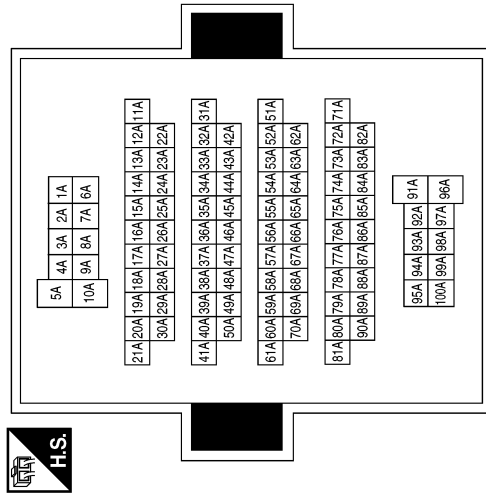

ABLIA5027GB

A  
B  
C  
D  
E  
F  
G  
H  
I  
J  
K  
EXL  
M  
N  
O  
P

# BACK-UP LAMP

< WIRING DIAGRAM >

Connector No.	D502
Connector Name	WIRE TO WIRE
Connector Color	GRAY

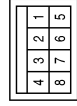

Terminal No.	2	Color of Wire	B	Signal Name	-
--------------	---	---------------	---	-------------	---

Connector No.	D501
Connector Name	WIRE TO WIRE
Connector Color	WHITE

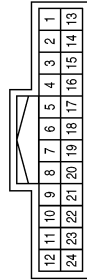

Terminal No.	22	Color of Wire	LG	Signal Name	-
--------------	----	---------------	----	-------------	---

Connector No.	B124
Connector Name	WIRE TO WIRE
Connector Color	WHITE



Terminal No.	18	Color of Wire	L	Signal Name	-
	19	Color of Wire	P	Signal Name	-

Connector No.	D550
Connector Name	WIRE TO WIRE
Connector Color	WHITE

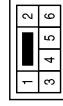

Terminal No.	1	Color of Wire	B	Signal Name	-
--------------	---	---------------	---	-------------	---

Connector No.	D507
Connector Name	WIRE TO WIRE
Connector Color	WHITE

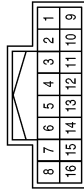

Terminal No.	8	Color of Wire	LG	Signal Name	-
--------------	---	---------------	----	-------------	---

Connector No.	D505
Connector Name	WIRE TO WIRE
Connector Color	WHITE



Terminal No.	1	Color of Wire	B	Signal Name	-
--------------	---	---------------	---	-------------	---

ABLIA5028GB



# BACK-UP LAMP

## < WIRING DIAGRAM >

Connector No.	D564
Connector Name	BACK-UP LAMP LH
Connector Color	WHITE



Terminal No.	Color of Wire	Signal Name
1	LG	-
2	B	-

Connector No.	D563
Connector Name	BACK-UP LAMP RH
Connector Color	WHITE



Terminal No.	Color of Wire	Signal Name
1	LG	-
2	B	-

Connector No.	D552
Connector Name	WIRE TO WIRE
Connector Color	WHITE

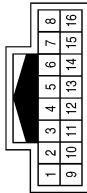

Terminal No.	Color of Wire	Signal Name
8	LG	-

A  
B  
C  
D  
E  
F  
G  
H  
I  
J  
K  
EXL  
M  
N  
O  
P

AALIA0903GB

# TRAILER TOW

< WIRING DIAGRAM >

## TRAILER TOW

Wiring Diagram

INFOID:000000009175361

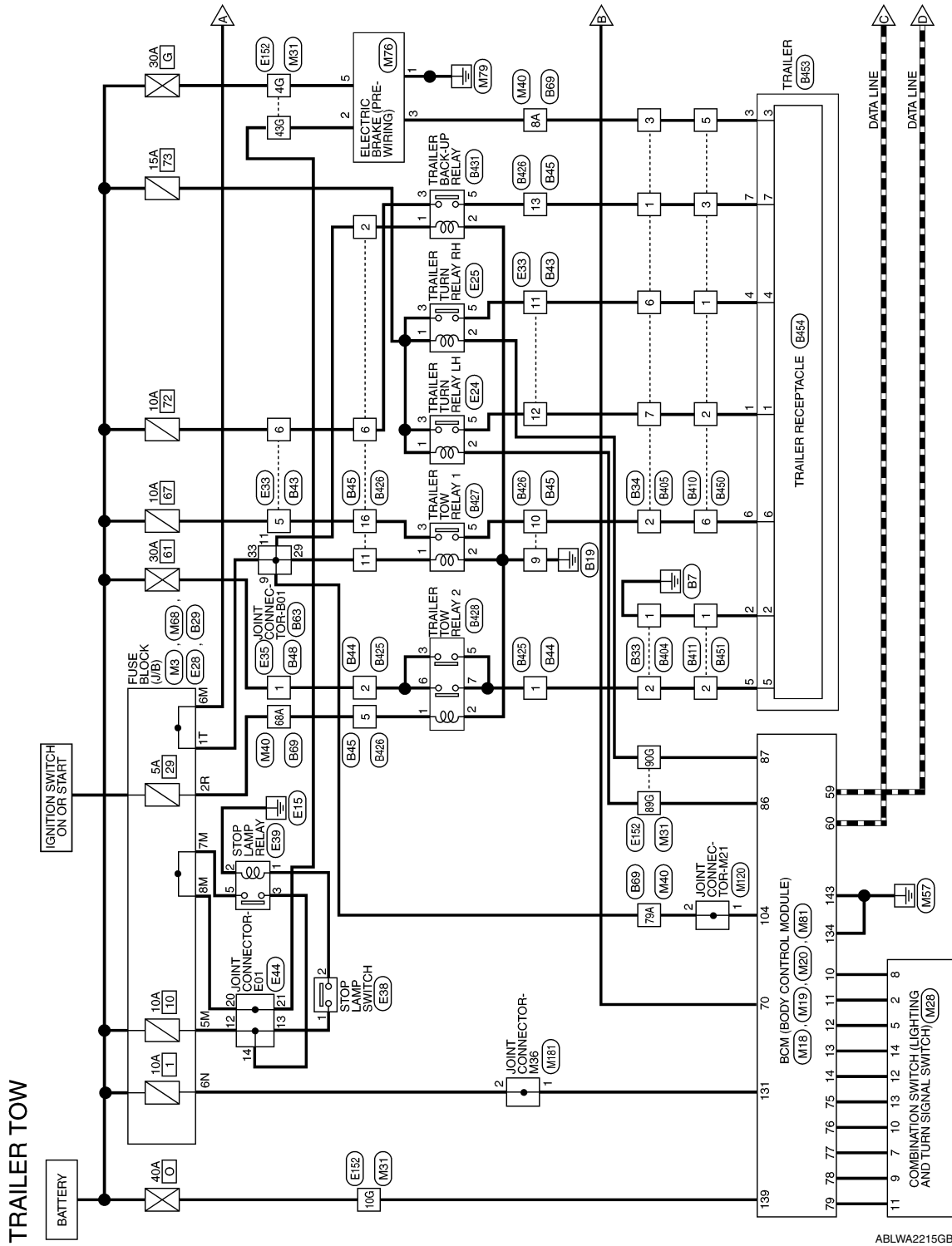

ABLWA2215GB

# TRAILER TOW

< WIRING DIAGRAM >

VD : WITH AROUND VIEW MONITOR  
 VK : WITHOUT AROUND VIEW MONITOR

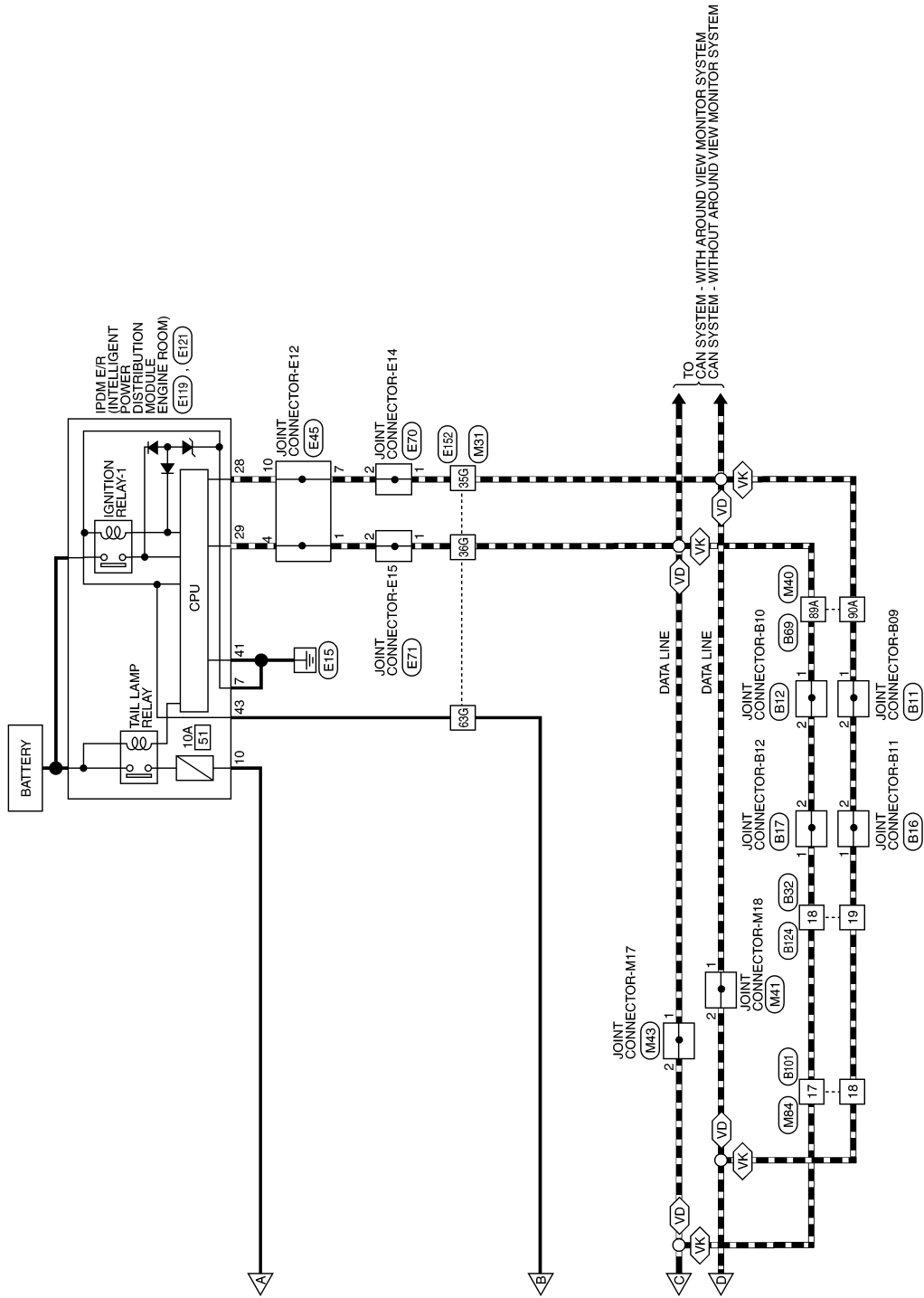

ABLWA2228GB

A  
 B  
 C  
 D  
 E  
 F  
 G  
 H  
 I  
 J  
 K  
 EXL  
 M  
 N  
 O  
 P

## TRAILER TOW CONNECTORS

Connector No.	M3
Connector Name	FUSE BLOCK (J/B)
Connector Color	WHITE

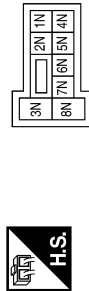

Terminal No.	Color of Wire	Signal Name
6N	W	-

Connector No.	M18
Connector Name	BCM (BODY CONTROL MODULE)
Connector Color	GREEN

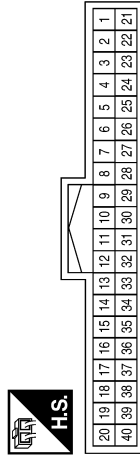

Terminal No.	Color of Wire	Signal Name
10	W	COMBI SW IN 5
11	BG	COMBI SW IN 4
12	R	COMBI SW IN 3
13	G	COMBI SW IN 2
14	P	COMBI SW IN 1

Connector No.	M19
Connector Name	BCM (BODY CONTROL MODULE)
Connector Color	BLACK

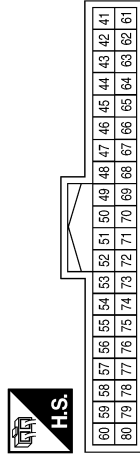

Terminal No.	Color of Wire	Signal Name
59	P	CAN-L
60	L	CAN-H
70	P	IGN USM OUT 1
75	BG	COMBI SW OUT 5
76	P	COMBI SW OUT 4
77	R	COMBI SW OUT 3
78	G	COMBI SW OUT 2
79	W	COMBI SW OUT 1

Connector No.	M20
Connector Name	BCM (BODY CONTROL MODULE)
Connector Color	GRAY

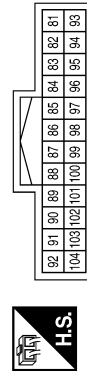

Terminal No.	Color of Wire	Signal Name
86	R	TRAILER FLASHER PL
87	P	TRAILER FLASHER RR
104	LG	REVERSE LAMP OUT

Connector No.	M28
Connector Name	COMBINATION SWITCH
Connector Color	WHITE

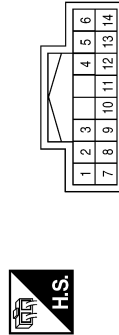

Terminal No.	Color of Wire	Signal Name
2	BG	-
5	R	-
7	R	-
8	W	-
9	G	-
10	P	-
11	W	-
12	P	-
13	BG	-
14	G	-

# TRAILER TOW

< WIRING DIAGRAM >

Connector No.	M41
Connector Name	JOINT CONNECTOR-M18
Connector Color	WHITE



Terminal No.	Color of Wire	Signal Name
1	P	-
2	P	-

Connector No.	M40
Connector Name	WIRE TO WIRE
Connector Color	GRAY

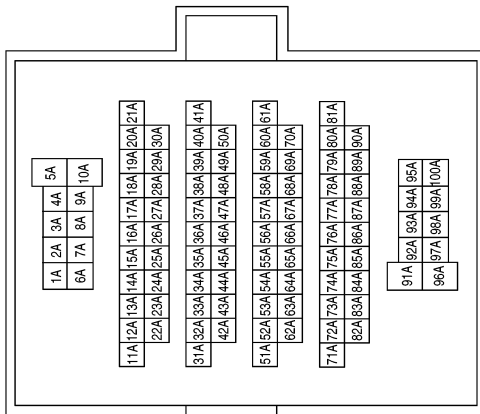

Terminal No.	Color of Wire	Signal Name
8A	W	-
68A	LG	-
79A	LG	-
89A	L	-
90A	P	-

Connector No.	M31
Connector Name	WIRE TO WIRE
Connector Color	WHITE

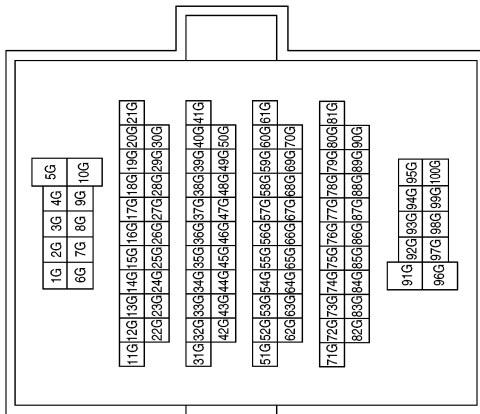

Terminal No.	Color of Wire	Signal Name
4G	G	-
10G	W	-
35G	P	-
36G	L	-
43G	W	-
63G	P	-
89G	R	-
90G	P	-

ABLIA5049GB

A  
B  
C  
D  
E  
F  
G  
H  
I  
J  
K  
EXL  
M  
N  
O  
P

# TRAILER TOW

< WIRING DIAGRAM >

Connector No.	M76
Connector Name	ELECTRIC BRAKE (PRE-WIRING)
Connector Color	WHITE



Terminal No.	Color of Wire	Signal Name
1	B	-
2	W	-
3	W	-
4	-	-
5	G	-
6	-	-

Connector No.	M68
Connector Name	FUSE BLOCK (J/B)
Connector Color	BROWN



Terminal No.	Color of Wire	Signal Name
2R	LG	-

Connector No.	M43
Connector Name	JOINT CONNECTOR-M17
Connector Color	WHITE



Terminal No.	Color of Wire	Signal Name
1	L	-
2	L	-

Connector No.	M120
Connector Name	JOINT CONNECTOR-M21
Connector Color	WHITE



Terminal No.	Color of Wire	Signal Name
1	LG	-
2	LG	-

Connector No.	M84
Connector Name	WIRE TO WIRE
Connector Color	WHITE

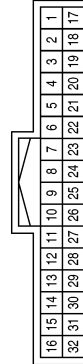

Terminal No.	Color of Wire	Signal Name
17	L	-
18	P	-

Connector No.	M81
Connector Name	BCM (BODY CONTROL MODULE)
Connector Color	WHITE

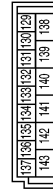

Terminal No.	Color of Wire	Signal Name
131	W	BAT BCM FUSE
134	B	GND 2
139	W	BAT POWER F/L
143	B	GND 1

ABLIA5102GB

# TRAILER TOW

## < WIRING DIAGRAM >

Connector No.	E25
Connector Name	TRAILER TURN RELAY RH
Connector Color	BLUE



Terminal No.	Color of Wire	Signal Name
1	P	-
2	L	-
3	P	-
5	G	-

Connector No.	E24
Connector Name	TRAILER TURN RELAY LH
Connector Color	BLUE



Terminal No.	Color of Wire	Signal Name
1	P	-
2	R	-
3	P	-
5	W	-

Connector No.	M181
Connector Name	JOINT CONNECTOR-M36
Connector Color	WHITE



Terminal No.	Color of Wire	Signal Name
1	W	-
2	W	-

Connector No.	E35
Connector Name	WIRE TO WIRE
Connector Color	GRAY



Terminal No.	Color of Wire	Signal Name
1	Y	-

Connector No.	E33
Connector Name	WIRE TO WIRE
Connector Color	WHITE



Terminal No.	Color of Wire	Signal Name
5	R	-
6	L	-
11	G	-
12	W	-

Connector No.	E28
Connector Name	FUSE BLOCK (J/B)
Connector Color	WHITE



Terminal No.	Color of Wire	Signal Name
5M	Y	-
6M	L	-
7M	R	-
8M	R	-

ABLIA5050GB

A  
B  
C  
D  
E  
F  
G  
H  
I  
J  
K  
EXL  
M  
N  
O  
P

# TRAILER TOW

< WIRING DIAGRAM >

Connector No.	E44
Connector Name	JOINT CONNECTOR-E01
Connector Color	WHITE

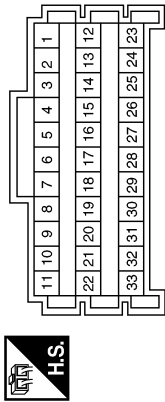

Terminal No.	Color of Wire	Signal Name
12	Y	-
13	Y	-
14	Y	-
20	R	-
21	R	-

Connector No.	E39
Connector Name	STOP LAMP RELAY
Connector Color	BLUE

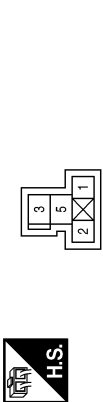

Terminal No.	Color of Wire	Signal Name
1	W	-
2	B	-
3	Y	-
5	R	-

Connector No.	E38
Connector Name	STOP LAMP SWITCH
Connector Color	WHITE

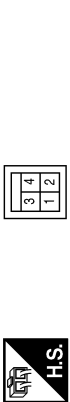

Terminal No.	Color of Wire	Signal Name
1	Y	-
2	W	-

Connector No.	E71
Connector Name	JOINT CONNECTOR-E15
Connector Color	BLACK

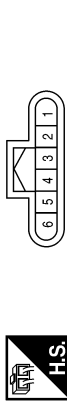

Terminal No.	Color of Wire	Signal Name
1	L	-
2	L	-

Connector No.	E70
Connector Name	JOINT CONNECTOR-E14
Connector Color	BLACK

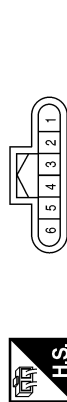

Terminal No.	Color of Wire	Signal Name
1	P	-
2	P	-

Connector No.	E45
Connector Name	JOINT CONNECTOR-E12
Connector Color	BLUE

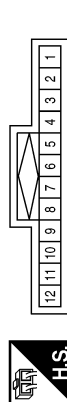

Terminal No.	Color of Wire	Signal Name
1	L	-
4	L	-
7	P	-
10	P	-

ABLIA5051GB



# TRAILER TOW

< WIRING DIAGRAM >

Connector No.	E121
Connector Name	IPDM E/R (INTELLIGENT POWER DISTRIBUTION MODULE ENGINE ROOM)
Connector Color	WHITE

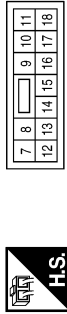

Terminal No.	Color of Wire	Signal Name
7	B	GND (POWER)
10	L	TAIL LH

Connector No.	E119
Connector Name	IPDM E/R (INTELLIGENT POWER DISTRIBUTION MODULE ENGINE ROOM)
Connector Color	WHITE

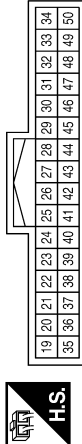

Terminal No.	Color of Wire	Signal Name
28	P	CAN-L
29	L	CAN-H
41	B	GND (SIGNAL)
43	L	IGN SIGNAL

Connector No.	B11
Connector Name	JOINT CONNECTOR-B09
Connector Color	WHITE



Terminal No.	Color of Wire	Signal Name
1	P	-
2	P	-

Terminal No.	Color of Wire	Signal Name
4G	R	-
10G	P	-
35G	P	-
36G	L	-
43G	R	-
63G	L	-
89G	R	-
90G	L	-

Connector No.	E152
Connector Name	WIRE TO WIRE
Connector Color	WHITE

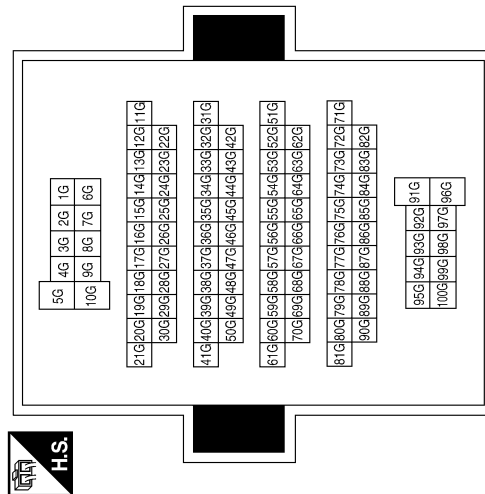

AALIA0946GB

A  
B  
C  
D  
E  
F  
G  
H  
I  
J  
K  
EXL  
M  
N  
O  
P

# TRAILER TOW

## < WIRING DIAGRAM >

Connector No.	B17
Connector Name	JOINT CONNECTOR-B12
Connector Color	WHITE



Terminal No.	Color of Wire	Signal Name
1	L	-
2	L	-

Connector No.	B16
Connector Name	JOINT CONNECTOR-B11
Connector Color	WHITE



Terminal No.	Color of Wire	Signal Name
1	P	-
2	P	-

Connector No.	B12
Connector Name	JOINT CONNECTOR-B10
Connector Color	WHITE



Terminal No.	Color of Wire	Signal Name
1	L	-
2	L	-

Connector No.	B33
Connector Name	WIRE TO WIRE
Connector Color	BLACK



Terminal No.	Color of Wire	Signal Name
1	B	-
2	W	-

Connector No.	B32
Connector Name	WIRE TO WIRE
Connector Color	WHITE

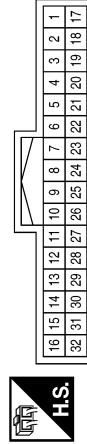

Terminal No.	Color of Wire	Signal Name
18	L	-
19	P	-

Connector No.	B29
Connector Name	FUSE BLOCK (J/B)
Connector Color	WHITE

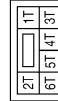

Terminal No.	Color of Wire	Signal Name
1T	W	-

AALIA0947GB

# TRAILER TOW

< WIRING DIAGRAM >

Connector No.	B44
Connector Name	WIRE TO WIRE
Connector Color	BLACK



Terminal No.	Color of Wire	Signal Name
1	W	-
2	W	-

Connector No.	B43
Connector Name	WIRE TO WIRE
Connector Color	WHITE

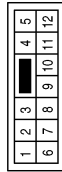

Terminal No.	Color of Wire	Signal Name
5	R	-
6	L	-
11	G	-
12	W	-

Connector No.	B34
Connector Name	WIRE TO WIRE
Connector Color	WHITE

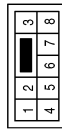

Terminal No.	Color of Wire	Signal Name
1	Y	-
2	W	-
3	G	-
6	G	-
7	W	-

Connector No.	B63
Connector Name	JOINT CONNECTOR-B01
Connector Color	WHITE

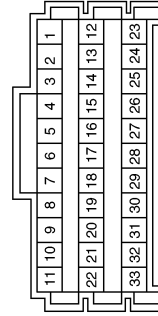

Terminal No.	Color of Wire	Signal Name
9	BR	-
11	BR	-
29	W	-
33	W	-

Connector No.	B48
Connector Name	WIRE TO WIRE
Connector Color	GRAY



Terminal No.	Color of Wire	Signal Name
1	W	-

Connector No.	B45
Connector Name	WIRE TO WIRE
Connector Color	WHITE



Terminal No.	Color of Wire	Signal Name
2	BR	-
5	P	-
6	L	-
9	GR	-
10	W	-
11	W	-
13	Y	-
16	R	-

ABLIA5052GB

A  
B  
C  
D  
E  
F  
G  
H  
I  
J  
K  
EXL  
M  
N  
O  
P

# TRAILER TOW

< WIRING DIAGRAM >

Connector No.	B101
Connector Name	WIRE TO WIRE
Connector Color	WHITE

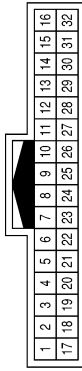
Terminal No.	Color of Wire	Signal Name
17	L	-
18	P	-

Terminal No.	Color of Wire	Signal Name
8A	G	-
68A	P	-
79A	BR	-
89A	L	-
90A	P	-

Connector No.	B69
Connector Name	WIRE TO WIRE
Connector Color	GRAY

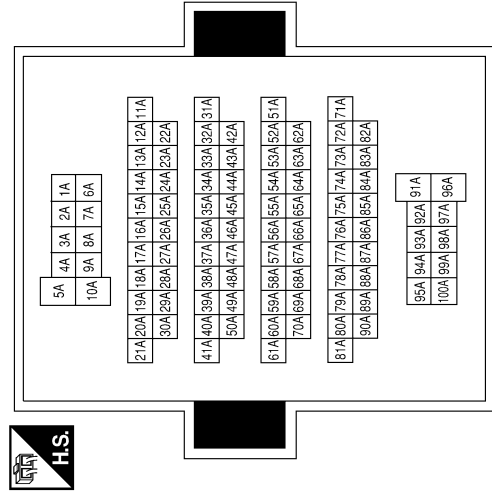

Connector No.	B405
Connector Name	WIRE TO WIRE
Connector Color	WHITE



Terminal No.	Color of Wire	Signal Name
1	Y	-
2	W	-
3	G	-
6	G	-
7	W	-

Connector No.	B404
Connector Name	WIRE TO WIRE
Connector Color	BLACK

Terminal No.	Color of Wire	Signal Name
1	B	-
2	W	-

Connector No.	B124
Connector Name	WIRE TO WIRE
Connector Color	WHITE



Terminal No.	Color of Wire	Signal Name
18	L	-
19	P	-

# TRAILER TOW

## < WIRING DIAGRAM >

Connector No.	B425
Connector Name	WIRE TO WIRE
Connector Color	BLACK



Terminal No.	Color of Wire	Signal Name
1	V	-
2	L	-

Connector No.	B411
Connector Name	WIRE TO WIRE
Connector Color	BLACK



Terminal No.	Color of Wire	Signal Name
1	B	-
2	W	-

Connector No.	B410
Connector Name	WIRE TO WIRE
Connector Color	GRAY



Terminal No.	Color of Wire	Signal Name
1	G	-
2	W	-
3	Y	-
5	G	-
6	W	-

Connector No.	B428
Connector Name	TRAILER TOW RELAY 2
Connector Color	BROWN



Terminal No.	Color of Wire	Signal Name
1	W	-
2	B	-
3	L	-
5	V	-
6	L	-
7	V	-

Connector No.	B427
Connector Name	TRAILER TOW RELAY 1
Connector Color	BLUE



Terminal No.	Color of Wire	Signal Name
1	G	-
2	B	-
3	R	-
5	W	-

Connector No.	B426
Connector Name	WIRE TO WIRE
Connector Color	WHITE

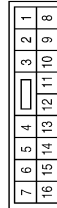

Terminal No.	Color of Wire	Signal Name
2	G	-
5	W	-
6	Y	-
9	B	-
10	W	-
11	G	-
13	LG	-
16	R	-

AALIA0950GB

A  
B  
C  
D  
E  
F  
G  
H  
I  
J  
K  
EXL  
M  
N  
O  
P

# TRAILER TOW

## < WIRING DIAGRAM >

Connector No.	B451
Connector Name	WIRE TO WIRE
Connector Color	BLACK



Terminal No.	Color of Wire	Signal Name
1	B	-
2	W	-

Connector No.	B450
Connector Name	WIRE TO WIRE
Connector Color	GRAY



Terminal No.	Color of Wire	Signal Name
1	G	-
2	W	-
3	Y	-
5	G	-
6	W	-

Connector No.	B431
Connector Name	TRAILER BACK-UP RELAY
Connector Color	BLUE



Terminal No.	Color of Wire	Signal Name
1	G	-
2	B	-
3	Y	-
5	LG	-

Terminal No.	Color of Wire	Signal Name
1	-	-
2	-	-
3	-	-
4	-	-
5	-	-
6	-	-
7	-	-

Connector No.	B454
Connector Name	TRAILER RECEPTACLE
Connector Color	BLACK

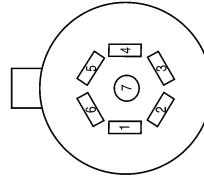

Connector No.	B453
Connector Name	TRAILER
Connector Color	BLACK



Terminal No.	Color of Wire	Signal Name
1	W	-
2	B	-
3	G	-
4	G	-
5	W	-
6	W	-
7	Y	-

AALIA0951GB

# DIAGNOSIS AND REPAIR WORKFLOW

< BASIC INSPECTION >

## BASIC INSPECTION

### DIAGNOSIS AND REPAIR WORKFLOW

Work Flow

INFOID:000000009175362

#### OVERALL SEQUENCE

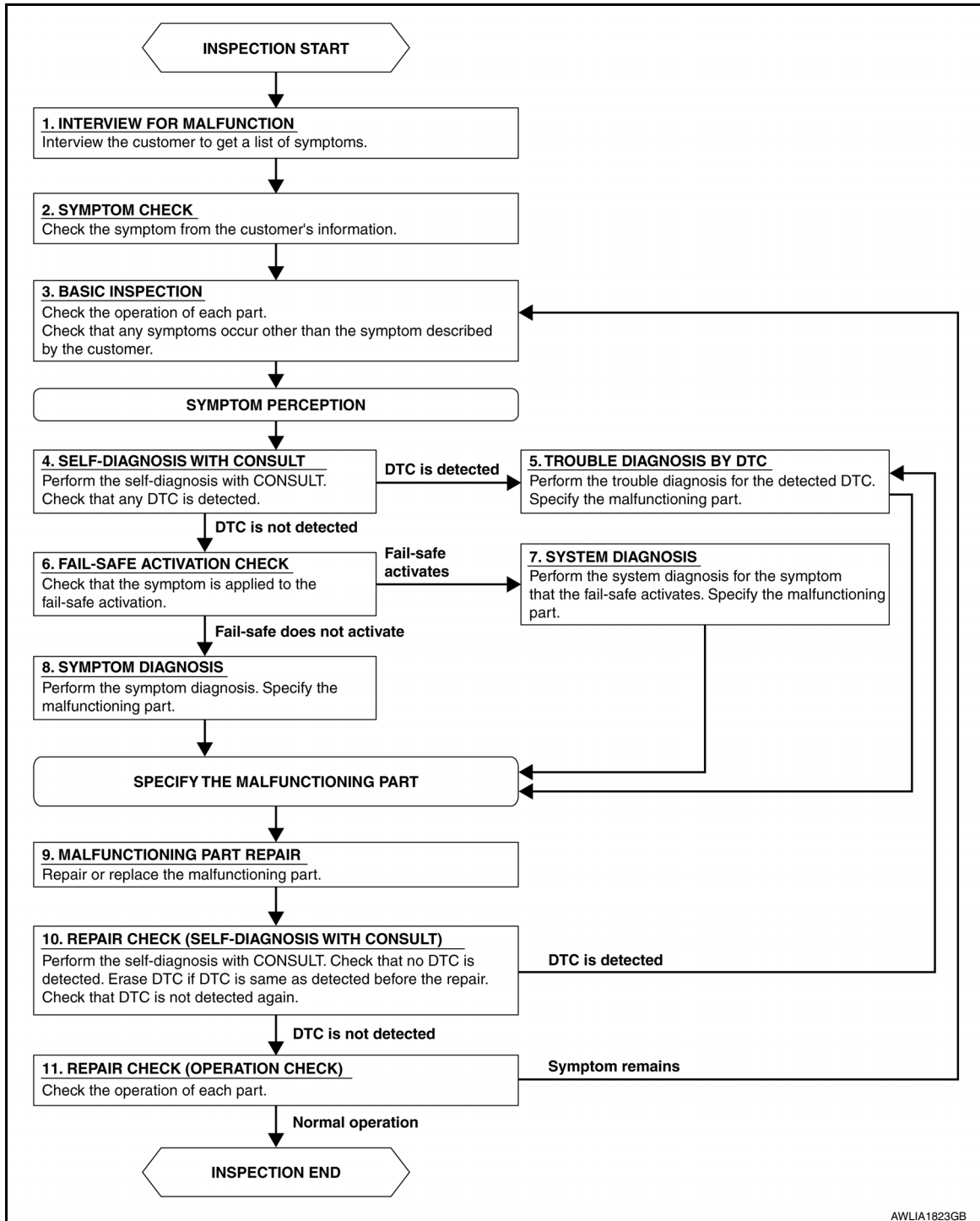

A  
B  
C  
D  
E  
F  
G  
H  
I  
J  
K  
EXL  
M  
N  
O  
P

# DIAGNOSIS AND REPAIR WORKFLOW

< BASIC INSPECTION >

---

DETAILED FLOW

## 1. INTERVIEW FOR MALFUNCTION

---

Find out what the customer's concerns are.

>> GO TO 2.

## 2. SYMPTOM CHECK

---

Verify the symptom from the customer's information.

>> GO TO 3.

## 3. BASIC INSPECTION

---

Check the operation of each part. Check any concerns that occur other than those mentioned in the customer interview.

>> GO TO 4.

## 4. SELF-DIAGNOSIS WITH CONSULT

---

Perform the self-diagnosis with CONSULT. Check that any DTC is detected.

Is any DTC detected?

YES >> GO TO 5.

NO >> GO TO 6.

## 5. TROUBLE DIAGNOSIS BY DTC

---

Perform the trouble diagnosis for the detected DTC. Specify the malfunctioning part.

>> GO TO 9.

## 6. FAIL-SAFE ACTIVATION CHECK

---

Determine if the customer's concern is related to fail-safe activation.

Does the fail-safe activate?

YES >> GO TO 7.

NO >> GO TO 8.

## 7. SYSTEM DIAGNOSIS

---

Perform the system diagnosis for the system in which the fail-safe activates. Specify the malfunctioning part.

>> GO TO 9.

## 8. SYMPTOM DIAGNOSIS

---

Perform the symptom diagnosis. Refer to [EXL-129, "Symptom Table"](#).

>> GO TO 9.

## 9. MALFUNCTION PART REPAIR

---

Repair or replace the malfunctioning part.

>> GO TO 10.

## 10. REPAIR CHECK (SELF-DIAGNOSIS WITH CONSULT)

---

Perform the self-diagnosis with CONSULT. Verify that no DTCs are detected. Erase all DTCs detected prior to the repair. Verify that DTC is not detected again.

Is any DTC detected?



# DIAGNOSIS AND REPAIR WORKFLOW

< BASIC INSPECTION >

---

YES >> GO TO 5.

NO >> GO TO 11.

## 11. REPAIR CHECK (OPERATION CHECK)

---

Check the operation of each part.

Does it operate normally?

YES >> Inspection End.

NO >> GO TO 3.

A

B

C

D

E

F

G

H

I

J

K

EXL

M

N

O

P

# POWER SUPPLY AND GROUND CIRCUIT

< DTC/CIRCUIT DIAGNOSIS >

## DTC/CIRCUIT DIAGNOSIS

### POWER SUPPLY AND GROUND CIRCUIT

#### BCM (BODY CONTROL MODULE)

#### BCM (BODY CONTROL MODULE) : Diagnosis Procedure

INFOID:000000009764019

Regarding Wiring Diagram information, refer to [BCS-55, "Wiring Diagram"](#).

### 1. CHECK FUSE AND FUSIBLE LINK

Check that the following fuse and fusible link are not blown.

Terminal No.	Signal name	Fuse and fusible link No.
139	Fusible link battery power	O (40A)
131	BCM battery fuse	1 (10A)

Is the fuse or fusible link blown?

YES >> Replace the blown fuse or fusible link after repairing the affected circuit.

NO >> GO TO 2

### 2. CHECK POWER SUPPLY CIRCUIT

1. Disconnect BCM connector M81.

2. Check voltage between BCM connector M81 terminals 131, 139 and ground.

BCM		Ground	Voltage (Approx.)
Connector	Terminal		
M81	131	—	Battery voltage
	139		

Is the inspection result normal?

YES >> GO TO 3

NO >> Repair or replace harness or connectors.

### 3. CHECK GROUND CIRCUIT

Check continuity between BCM connector M81 terminals 134, 143 and ground.

BCM		Ground	Continuity
Connector	Terminal		
M81	134	—	Yes
	143		

Is the inspection result normal?

YES >> Inspection End.

NO >> Repair or replace harness or connectors.

### IPDM E/R (INTELLIGENT POWER DISTRIBUTION MODULE ENGINE ROOM)

#### IPDM E/R (INTELLIGENT POWER DISTRIBUTION MODULE ENGINE ROOM) : Diagnosis Procedure

INFOID:000000009764018

Regarding Wiring Diagram information, refer to [PCS-21, "Wiring Diagram"](#).

# POWER SUPPLY AND GROUND CIRCUIT

< DTC/CIRCUIT DIAGNOSIS >

## 1. CHECK FUSIBLE LINKS

Check that the following fusible links are not blown.

Terminal No.	Signal name	Fusible link No.
1	Fusible link main	E (80A)
2	Fusible link IPDM E/R	A (250A), C (80A)
3	Fusible link ignition switch	A (250A), B (100A), K (40A)

Is the fusible link blown?

YES >> Replace the blown fusible link after repairing the affected circuit.

NO >> GO TO 2

## 2. CHECK POWER SUPPLY CIRCUIT

1. Disconnect IPDM E/R connectors E118 and E120.
2. Check voltage between IPDM E/R connectors and ground.

IPDM E/R		Ground	Voltage (Approx.)
Connector	Terminal		
E118	1	—	Battery voltage
	2		
E120	3		

Is the inspection result normal?

YES >> GO TO 3

NO >> Repair or replace harness or connectors.

## 3. CHECK GROUND CIRCUIT

1. Disconnect IPDM E/R connectors E119 and E121.
2. Check continuity between IPDM E/R connectors and ground.

IPDM E/R		Ground	Continuity
Connector	Terminal		
E121	7	—	Yes
E119	41		

Is the inspection result normal?

YES >> Inspection End.

NO >> Repair or replace harness or connectors.

A  
B  
C  
D  
E  
F  
G  
H  
I  
J  
K  
EXL  
M  
N  
O  
P

# HEADLAMP (HI) CIRCUIT

< DTC/CIRCUIT DIAGNOSIS >

## HEADLAMP (HI) CIRCUIT

### Description

INFOID:000000009175365

The IPDM E/R (intelligent power distribution module engine room) controls the headlamp high relay based on inputs from the BCM over the CAN communication lines. When the headlamp high relay is energized, power flows through fuses 34 and 35, located in the IPDM E/R. Power then flows to the front combination lamps to the headlamp high beam.

### Component Function Check

INFOID:000000009175366

#### 1. CHECK HEADLAMP (HI) OPERATION

##### ⊗ WITHOUT CONSULT

1. Start IPDM E/R auto active test. Refer to [PCS-8, "Diagnosis Description"](#).
2. Check that the headlamp switches to the high beam.

##### Ⓟ WITH CONSULT

1. Select EXTERNAL LAMPS of IPDM E/R active test item.
2. While operating the test items, check that the headlamp switches to the high beam.

**HI** : Headlamp switches to the high beam.

**OFF** : Headlamp OFF

Does the headlamp switch to the high beam?

- YES >> Headlamp (HI) circuit is normal.  
NO >> Refer to [EXL-108, "Diagnosis Procedure"](#).

### Diagnosis Procedure

INFOID:000000009175367

Regarding Wiring Diagram - Refer to [EXL-21, "Wiring Diagram"](#).

#### 1. CHECK HEADLAMP (HI) FUSES

1. Turn the ignition switch OFF.
2. Check that the following fuses are not blown.

Unit	Location	Fuse No.	Capacity
Headlamp HI (LH)	IPDM E/R	35	10A
Headlamp HI (RH)	IPDM E/R	34	10A

Is the fuse blown?

- YES >> Replace the blown fuse after repairing the affected circuit.  
NO >> GO TO 2.

#### 2. CHECK HEADLAMP (HI) OUTPUT VOLTAGE

##### Ⓟ CONSULT ACTIVE TEST

1. Turn the ignition switch OFF.
2. Disconnect the front combination lamp harness connector E233 or E238.
3. Turn the ignition switch ON.
4. Select EXTERNAL LAMPS of IPDM E/R active test item.
5. With EXTERNAL LAMP ON, check the voltage between the combination lamp harness connector and ground.

(+)		Terminal	(-)	Voltage
Connector				
RH	E238	3	Ground	Battery voltage
LH	E233			

# HEADLAMP (HI) CIRCUIT

## < DTC/CIRCUIT DIAGNOSIS >

### Is the inspection result normal?

- YES >> GO TO 4.  
NO >> GO TO 3.

### 3. CHECK HEADLAMP (HI) CIRCUIT FOR OPEN

1. Turn the ignition switch OFF.
2. Disconnect IPDM E/R harness connector E217.
3. Check continuity between the IPDM E/R harness connector E217 and the front combination lamp harness connector.

IPDM E/R		Front combination lamp		Continuity
Connector	Terminal	Connector	Terminal	
RH	E217	80	E238	Yes
LH		81	E233	

### Is the inspection result normal?

- YES >> Replace IPDM E/R. Refer to [PCS-32, "Removal and Installation"](#).  
NO >> Repair or replace the harness or connector.

### 4. CHECK FRONT COMBINATION LAMP (HI) GROUND CIRCUIT

1. Turn the ignition switch OFF.
2. Check continuity between the front combination lamp harness connector terminal 4 and ground.

Connector	Terminal	—	Continuity
RH	E238	4	Ground
LH	E233		

### Is the inspection result normal?

- YES >> Replace the headlamp bulb.  
NO >> Repair or replace the harness or connector.

A  
B  
C  
D  
E  
F  
G  
H  
I  
J  
K  
L  
M  
N  
O  
P

EXL

# HEADLAMP (LO) CIRCUIT

< DTC/CIRCUIT DIAGNOSIS >

## HEADLAMP (LO) CIRCUIT

### Description

INFOID:000000009175368

The IPDM E/R (intelligent power distribution module engine room) controls the headlamp low relay based on inputs from the BCM over the CAN communication lines. When the headlamp low relay is energized, power flows through fuses 36 and 37, located in the IPDM E/R. Power then flows to the front combination lamps to the headlamp low beam.

### Component Function Check

INFOID:000000009175369

#### 1. CHECK HEADLAMP (LO) OPERATION

##### ⊗ WITHOUT CONSULT

1. Start IPDM E/R auto active test. Refer to [PCS-8, "Diagnosis Description"](#).
2. Check that the headlamp is turned ON.

##### NOTE:

HI/LO is repeated 1 second each when using the IPDM E/R auto active test.

##### Ⓟ CONSULT

1. Select EXTERNAL LAMPS of IPDM E/R active test item.
2. While operating the test item, check that the headlamp is turned ON.

**LO : Headlamp ON**  
**OFF : Headlamp OFF**

##### Is the headlamp turned ON?

- YES >> Headlamp (LO) is normal.  
NO >> Refer to [EXL-110, "Diagnosis Procedure"](#).

### Diagnosis Procedure

INFOID:000000009175370

Regarding Wiring Diagram information - Refer to [EXL-21, "Wiring Diagram"](#).

#### 1. CHECK HEADLAMP (LO) FUSES

1. Turn the ignition switch OFF.
2. Check that the following fuses are not blown.

Unit	Location	Fuse No.	Capacity
Headlamp LO (LH)	IPDM E/R	37	15A
Headlamp LO (RH)	IPDM E/R	36	15A

##### Is the fuse blown?

- YES >> Replace the blown fuse after repairing the affected circuit.  
NO >> GO TO 2.

#### 2. CHECK HEADLAMP (LO) OUTPUT VOLTAGE

##### Ⓟ CONSULT

1. Turn the ignition switch OFF.
2. Disconnect the front combination lamp harness connector E232 or E237.
3. Turn the ignition switch ON.
4. Select EXTERNAL LAMPS of IPDM E/R active test item.
5. With EXTERNAL LAMP ON, check the voltage between the front combination lamp harness connector E232 or E237 terminal 1 and ground.

(+)		(-)	Voltage
Connector	Terminal		

# HEADLAMP (LO) CIRCUIT

## < DTC/CIRCUIT DIAGNOSIS >

RH	E232	1	Ground	Battery voltage
LH	E237			

Is the inspection result normal?

YES >> GO TO 4.

NO >> GO TO 3.

### 3. CHECK HEADLAMP (LO) CIRCUIT FOR OPEN

1. Turn the ignition switch OFF.
2. Disconnect IPDM E/R connector E217.
3. Check continuity between the IPDM E/R harness connector and the front combination lamp harness connector E232 or E237.

IPDM E/R		Front combination lamp		Continuity
Connector	Terminal	Connector	Terminal	
RH	E217	E232	1	Yes
LH				
		E237		

Is the inspection result normal?

YES >> Replace IPDM E/R. Refer to [PCS-32, "Removal and Installation"](#).

NO >> Repair or replace the harness or connector.

### 4. CHECK FRONT COMBINATION LAMP (LO) GROUND CIRCUIT

1. Turn the ignition switch OFF.
2. Check continuity between the front combination lamp harness connector E232 or E237 terminal 2 and ground.

Connector	Terminal	—	Continuity
RH	E232	Ground	Yes
LH	E237		

Is the inspection result normal?

YES >> Replace the headlamp bulb.

NO >> Repair or replace the harness or connector.

A  
B  
C  
D  
E  
F  
G  
H  
I  
J  
K  
M  
N  
O  
P

EXL

# DAYTIME LIGHT RELAY CIRCUIT

< DTC/CIRCUIT DIAGNOSIS >

## DAYTIME LIGHT RELAY CIRCUIT

### Description

INFOID:000000009175371

The BCM sends a daytime light request to the IPDM E/R via the CAN communication lines. The power flows through fuse 43 located in IPDM E/R to the daytime light relay coil. When the IPDM E/R operates the daytime light relay, power is sent to the daytime lamps.

### Diagnosis Procedure

INFOID:000000009175372

Regarding Wiring Diagram information, refer to [EXL-29. "Wiring Diagram"](#).

### 1. CHECK DAYTIME LIGHT RELAY VOLTAGE SUPPLY

1. Turn the ignition switch OFF.
2. Disconnect the daytime light relay harness connector E4.
3. Turn the ignition switch ON.
4. Check the voltage between the following daytime light relay harness connector E4 terminals and ground.

(+)		(-)	Voltage
Connector	Terminal		
E4	2	Ground	Battery voltage
	5		
	7		

Is the inspection result normal?

YES >> GO TO 3.

NO >> GO TO 2.

### 2. CHECK DAYTIME LIGHT RELAY CIRCUIT

1. Turn the ignition switch OFF.
2. Disconnect IPDM E/R harness connector E121.
3. Check continuity between the IPDM E/R harness connector E121 and the daytime light relay harness connector E4.

Daytime light relay		IPDM E/R		Continuity
Connector	Terminal	Connector	Terminal	
E4	2	E121	14	Yes
	5			
	7			

4. Check continuity between the IPDM E/R harness connector E121 and ground.

Connector	Terminal	(-)	Continuity
E121	14	Ground	No

Is the inspection result normal?

YES >> Replace IPDM E/R. Refer to [PCS-32. "Removal and Installation"](#).

NO >> Repair or replace the harness or connector.

### 3. CHECK DAYTIME LAMP RELAY COIL CIRCUIT

1. Check continuity between the IPDM E/R harness connector E218 and daytime light relay harness connector E4.



# DAYTIME LIGHT RELAY CIRCUIT

## < DTC/CIRCUIT DIAGNOSIS >

IPDM E/R		Daytime light relay		Continuity
Connector	Terminal	Connector	Terminal	
E218	85	E4	1	Yes

2. Check continuity between the IPDM E/R harness connector E218 and ground.

Connector	Terminal	Ground	Continuity
E218	85		No

Is the inspection result normal?

YES >> GO TO 4.

NO >> Repair or replace the harness or connector.

### 4.CHECK DAYTIME LIGHT RELAY

Check the daytime light relay. Refer to [EXL-113, "Component Inspection"](#).

Is the inspection result normal?

YES >> GO TO 5.

NO >> Replace relay.

### 5.CHECK DAYTIME LAMP CIRCUIT FOR OPEN

- Turn the ignition switch OFF.
- Disconnect the front fog lamp harness connector E303 or E304 in question.
- Check continuity between the daytime light relay harness connector E4 and the front fog lamp harness connector E303 or E304.

Front fog lamp		Daytime light relay		Continuity
Connector	Terminal	Connector	Terminal	
LH E303	3	E4	3	Yes
RH E304			6	

Is the inspection result normal?

YES >> GO TO 6.

NO >> Repair or replace the harness or connector.

### 6.CHECK DAYTIME LAMP GOUND CIRCUIT FOR OPEN

- Disconnect front fog lamp harness connector E303 or E304 in question.
- Check continuity between the front fog lamp harness connector E303 or E304 terminal 12 and ground.

Connector	Terminal	(-)	Continuity
LH E303	4	Ground	Yes
RH E304			

Is the inspection result normal?

YES >> Check the daytime light system relay. Refer to [EXL-113, "Component Inspection"](#).

NO >> Repair or replace the harness or connector.

## Component Inspection

INFOID:000000009175373

### 1. CHECK DAYTIME LIGHT RELAY CONTINUITY

- Turn ignition switch OFF.
- Remove daytime light relay.
- Apply 12V direct current between daytime light relay terminals and check continuity.

## DAYTIME LIGHT RELAY CIRCUIT

< DTC/CIRCUIT DIAGNOSIS >

Terminal	Condition	Continuity
3 - 5	12V direct current applied between terminals 1 and 2.	Yes
6 - 7	No current applied.	No

Is the inspection result normal?

- YES >> Inspection End.
- NO >> Replace daytime light relay.

# FRONT FOG LAMP CIRCUIT

< DTC/CIRCUIT DIAGNOSIS >

## FRONT FOG LAMP CIRCUIT

### Description

INFOID:000000009175374

The IPDM E/R (intelligent power distribution module engine room) controls the front fog lamp relay based on inputs from the BCM via the CAN communication lines. When the front fog lamp relay is energized, power flows from the front fog lamp relay in the IPDM E/R to the front fog lamps.

### Component Function Check

INFOID:000000009175375

#### 1. CHECK FRONT FOG LAMP OPERATION

##### WITHOUT CONSULT

1. Activate IPDM E/R auto active test. Refer to [PCS-8, "Diagnosis Description"](#).
2. Check that the front fog lamp is turned ON.

##### WITH CONSULT

1. Select EXTERNAL LAMPS of IPDM E/R active test item.
2. While operating the test items, Check that the front fog lamp is turned ON.

**Fog** : Front fog lamp ON  
**Off** : Front fog lamp OFF

##### Is the front fog lamp turned ON?

- YES >> Front fog lamp circuit is normal.  
NO >> Refer to [EXL-115, "Diagnosis Procedure"](#).

### Diagnosis Procedure

INFOID:000000009175376

Regarding Wiring Diagram information, refer to [EXL-48, "Wiring Diagram"](#).

#### 1. CHECK FRONT FOG LAMP FUSE

1. Turn the ignition switch OFF.
2. Check that the following fuse is not blown.

Unit	Location	Fuse No.	Capacity
Front fog lamp	IPDM E/R	42	15A

##### Is the fuse blown?

- YES >> Replace the blown fuse after repairing the affected circuit.  
NO >> GO TO 2.

#### 2. CHECK FRONT FOG LAMP OUTPUT VOLTAGE

1. Turn the ignition switch OFF.
2. Disconnect the front fog lamp harness connector E305 or E306.
3. Turn the ignition switch ON.
4. Turn the front fog lamps ON.
5. Check the voltage between the fog lamp harness connector E305 or E306 terminal 1 and ground.

(+)		Terminal	(-)	Voltage (Approx.)
Connector				
LH	E305	1	Ground	Battery voltage
RH	E306			

##### Is the inspection result normal?

- YES >> GO TO 4.  
NO >> GO TO 3.

# FRONT FOG LAMP CIRCUIT

< DTC/CIRCUIT DIAGNOSIS >

## 3. CHECK FRONT FOG LAMP OPEN CIRCUIT

1. Turn the ignition switch OFF.
2. Disconnect IPDM E/R harness connector E217.
3. Check continuity between the IPDM E/R harness connector E217 and the front fog lamp harness connector E305 or E306.

IPDM E/R		Front fog lamp		Continuity
Connector	Terminal	Connector	Terminal	
LH	E217	E305	1	Yes
RH		79		
		E306		

Is the inspection result normal?

YES >> Replace IDPM E/R. Refer to [PCS-32, "Removal and Installation"](#).

NO >> Repair or replace the harness or connector.

## 4. CHECK FRONT FOG LAMP GROUND CIRCUIT

1. Turn the ignition switch OFF.
2. Check continuity between the front fog lamp harness connector E305 or E306 terminal 2 and ground.

Connector		Terminal	—	Continuity
LH	E305	2	Ground	Yes
RH	E306			

Is the inspection result normal?

YES >> Inspect the fog lamp bulb.

NO >> Repair or replace the harness or connector.

# PARKING LAMP CIRCUIT

< DTC/CIRCUIT DIAGNOSIS >

## PARKING LAMP CIRCUIT

### Description

INFOID:000000009175377

The IPDM E/R (intelligent power distribution module engine room) controls the tail lamp relay based on inputs from the BCM via the CAN communication lines. When the tail lamp relay is energized, power flows through fuse 51 and 52, located in the IPDM E/R. Power then flows to the front combination lamps, rear combination lamps and license plate lamps.

### Component Function Check

INFOID:000000009175378

#### 1. CHECK PARKING LAMP OPERATION

##### WITHOUT CONSULT

1. Activate IPDM E/R auto active test. Refer to [PCS-8, "Diagnosis Description"](#).
2. Check that the parking lamp is turned ON.

##### WITH CONSULT

1. Select EXTERNAL LAMPS of IPDM E/R active test item.
2. While operating the test items, check that the parking lamp is turned ON.

**TAIL : Parking lamp ON**  
**Off : Parking lamp OFF**

##### Is the parking lamp turned ON?

- YES >> Parking lamp circuit is normal.  
NO >> Refer to [EXL-117, "Diagnosis Procedure"](#).

### Diagnosis Procedure

INFOID:000000009175379

Regarding Wiring Diagram information, refer to [EXL-64, "Wiring Diagram"](#).

#### 1. CHECK PARKING LAMP FUSES

1. Turn the ignition switch OFF.
2. Check that the following fuses are not blown.

Unit	Location	Fuse No.	Capacity
Parking lamps	IPDM E/R	51	10A
		52	10A

##### Is the fuse blown?

- YES >> Replace the blown fuse after repairing the affected circuit.  
NO >> GO TO 2.

#### 2. CHECK TAIL LAMP RELAY OUTPUT (VOLTAGE)

1. Disconnect the front or rear combination lamp connector or license plate lamp connector in question.
2. Turn the ignition switch ON.
3. Turn the parking lamps ON.
4. With the parking lamps ON, check voltage between the front combination lamp (parking) connector and ground.

Front combination lamp (parking)		Terminal	(-)	Voltage (Approx.)
Connector				
LH	E235	7	Ground	Battery voltage
RH	E240			

# PARKING LAMP CIRCUIT

## < DTC/CIRCUIT DIAGNOSIS >

5. With the parking lamps ON, check voltage between the front combination lamp (side marker) connector and ground.

Front combination lamp (side marker)		Terminal	(-)	Voltage (Approx.)
Connector				
LH	E236	9	Ground	Battery voltage
RH	E241			

6. With the parking lamps ON, check voltage between the rear combination lamp (tail) connector and ground.

Rear combination lamp (tail)		Terminal	(-)	Voltage (Approx.)
Connector				
LH	B406	3	Ground	Battery voltage
RH	B407			

7. With the parking lamps ON, check voltage between the rear combination lamp (side marker) connector and ground.

Rear combination lamp (side marker)		Terminal	(-)	Voltage (Approx.)
Connector				
LH	B412	6	Ground	Battery voltage
RH	B413			

8. With the parking lamps ON, check voltage between the license plate lamp connector and ground

License plate lamp		Terminal	(-)	Voltage (Approx.)
Connector				
LH	D561	1	Ground	Battery voltage
RH	D562			

Are the inspection result normal?

- YES >> GO TO 4.  
NO >> GO TO 3.

### 3. CHECK PARKING LAMP CIRCUIT (OPEN)

1. Turn the ignition switch OFF.
2. Disconnect IPDM E/R connector.
3. Check continuity between the IPDM E/R harness connector and the front combination lamp (parking) harness connector.

IPDM E/R		Terminal	Front combination lamp (parking)		Continuity
Connector			Connector	Terminal	
LH	E218	90	E235	7	Yes
RH			E240		

4. Check continuity between the IPDM E/R harness connector and the front combination lamp (side marker) harness connector.

IPDM E/R		Front combination lamp (side marker)		
Connector	Terminal	Connector	Terminal	

# PARKING LAMP CIRCUIT

## < DTC/CIRCUIT DIAGNOSIS >

LH	E218	90	E236	9	Yes
RH			E241		

5. Check continuity between the IPDM E/R harness connector and the rear combination lamp (tail) harness connector.

IPDM E/R			Rear combination lamp (tail)		Continuity
Connector	Terminal	Connector	Terminal		
LH	E121	10	B406	3	Yes
RH		9	B407		

6. Check continuity between the IPDM E/R harness connector and the rear combination lamp (side marker) harness connector.

IPDM E/R			Rear combination lamp (side marker)		Continuity
Connector	Terminal	Connector	Terminal		
LH	E218	10	B412	6	Yes
RH		9	B413		

7. Check continuity between the IPDM E/R harness connector and license plate lamp connector.

IPDM E/R			License plate lamp		Continuity
Connector	Terminal	Connector	Terminal		
LH	E121	10	D561	1	Yes
RH		D562			

Are the inspection result normal?

YES >> Replace IPDM E/R. Refer to [PCS-32, "Removal and Installation"](#).

NO >> Repair or replace the harness or connector.

## 4. CHECK PARKING LAMP GROUND CIRCUITS

- Turn the ignition switch OFF.
- Check continuity between the front combination lamp (parking) harness connector and ground.

Front combination lamp (parking)			(-)	Continuity
Connector	Terminal			
LH	E235	8	Ground	Yes
RH	E240			

3. Check continuity between the front combination lamp (side marker) harness connector and ground.

Front combination lamp (side marker)			(-)	Continuity
Connector	Terminal			
LH	E236	10	Ground	Yes
RH	E241			

4. Check continuity between the rear combination lamp (tail) harness connector and ground.

Rear combination lamp (tail)			(-)	Continuity
Connector	Terminal			

## PARKING LAMP CIRCUIT

### < DTC/CIRCUIT DIAGNOSIS >

LH	B406	2	Ground	Yes
RH	B407			

5. Check continuity between the rear combination lamp (side marker) harness connector and ground.

Rear combination lamp (side marker)		Terminal	(-)	Continuity
Connector				
LH	B412	7	Ground	Yes
RH	B413			

6. Check continuity between the license plate lamp harness connector and ground.

License plate lamp		Terminal	(-)	Continuity
Connector				
LH	D561	2	Ground	Yes
RH	D562			

#### Are the inspection result normal?

- YES >> Inspect the parking, side marker or license plate lamp bulb.  
 NO >> Repair or replace the harness or connector.



# TURN SIGNAL LAMP CIRCUIT

< DTC/CIRCUIT DIAGNOSIS >

## TURN SIGNAL LAMP CIRCUIT

### Description

INFOID:000000009175380

The BCM monitors inputs from the combination switch (lighting and turn signal switch) to determine when to activate the turn signals. The BCM outputs voltage to the left and right turn signals during turn signal operation or both during hazard warning operation. The BCM sends a turn signal indicator request to the combination meter via the CAN communication lines.

The BCM performs the fast flasher operation (fail-safe) if any bulb or harness of the turn signal lamp circuit is open.

#### NOTE:

Turn signal lamp blinks at normal speed when using the hazard warning lamp.

### Component Function Check

INFOID:000000009175381

#### 1. CHECK TURN SIGNAL LAMP

##### CONSULT

1. Select FLASHER of BCM (FLASHER) active test item.
2. While operating the test items, check that the turn signal lamp blinks.

- LH** : Turn signal lamps (LH) ON
- RH** : Turn signal lamps (RH) ON
- Off** : Turn signal lamps OFF

Is the inspection result normal?

- YES >> Turn signal lamp circuit is normal.
- NO >> Refer to [EXL-121, "Diagnosis Procedure"](#).

### Diagnosis Procedure

INFOID:000000009175382

Regarding Wiring Diagram information, refer to [EXL-56, "Wiring Diagram"](#).

#### 1. CHECK TURN SIGNAL LAMP BULB

Check the applicable lamp bulb to be sure the proper bulb standard is in use and the bulb is not open.

Is the inspection result normal?

- YES >> GO TO 2.
- NO >> Replace the bulb.

#### 2. CHECK TURN SIGNAL LAMP OUTPUT VOLTAGE

1. Turn the ignition switch OFF.
2. Disconnect the front or rear combination lamp harness connector in question.
3. Turn the ignition switch ON.
4. Operate the turn signal switch.
5. While the turn signal is operating, check the voltage between the front combination lamp harness connector and ground.

(+)		(-)	Voltage (Approx.)
Connector	Terminal		

# TURN SIGNAL LAMP CIRCUIT

## < DTC/CIRCUIT DIAGNOSIS >

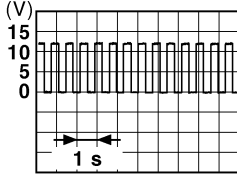
RH	E239	5	Ground	
LH	E234			

PKID0926E

6. While the turn signal is operating, check the voltage between the rear combination lamp harness connector and ground.

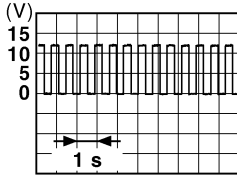
(+)		Terminal	(-)	Voltage (Approx.)
Connector				
RH	B409	4	Ground	
LH	B408			

PKID0926E

Is the inspection result normal?

YES >> GO TO 5.

NO >> GO TO 3.

### 3. CHECK TURN SIGNAL LAMP CIRCUIT FOR OPEN

1. Turn the ignition switch OFF.
2. Disconnect BCM harness connector M20 or M80.
3. Check continuity between the BCM harness connector M80 and the front combination lamp harness connector.

BCM			Front combination lamp		Continuity
Connector	Terminal	Connector	Terminal		
LH	M80	E234	5	Yes	
RH		117			E239

4. Check continuity between the BCM harness connector M20 and the rear combination lamp harness connector.

BCM			Rear combination lamp		Continuity
Connector	Terminal	Connector	Terminal		
LH	M20	B408	4	Yes	
RH		103			B409

Is the inspection result normal?

YES >> GO TO 4.

NO >> Repair or replace the harness or connector.

### 4. CHECK TURN SIGNAL LAMP SHORT CIRCUIT

1. Check continuity between the BCM harness connector M80 and ground.

# TURN SIGNAL LAMP CIRCUIT

## < DTC/CIRCUIT DIAGNOSIS >

BCM			Ground	Continuity
Connector		Terminal		No
LH	M80	117		
RH		105		

2. Check continuity between the BCM harness connector M20 and ground.

BCM			Ground	Continuity
Connector		Terminal		No
LH	M20	103		
RH		92		

Is the inspection result normal?

YES >> Replace BCM. Refer to [BCS-80, "Removal and Installation"](#).

NO >> Repair or replace the harness or connector.

## 5. CHECK TURN SIGNAL LAMP GROUND CIRCUIT

1. Turn the ignition switch OFF.
2. Check continuity between the front combination lamp harness connector and ground.

Front combination lamp			(-)	Continuity
Connector		Terminal		
LH	E234	6	Ground	Yes
RH	E239			

3. Check continuity between the rear combination lamp harness connector and ground.

Rear combination lamp			(-)	Continuity
Connector		Terminal		
LH	B408	5	Ground	Yes
RH	B409			

Is the inspection result normal?

YES >> Replace the malfunctioning lamp.

NO >> Repair or replace the harness or connector.

# OPTICAL SENSOR

< DTC/CIRCUIT DIAGNOSIS >

## OPTICAL SENSOR

### Description

INFOID:000000009175383

The optical sensor measures ambient light and transmits the optical sensor signal to the BCM.

### Component Function Check

INFOID:000000009175384

#### 1.CHECK OPTICAL SENSOR SIGNAL TO BCM

##### CONSULT

1. Turn the ignition switch ON.
2. Select OPTI SEN (DTCT) of BCM (HEAD LAMP) DATA MONITOR item.
3. Turn the lighting switch to AUTO.

Monitor item	Condition	Voltage (Approx.)
OPTI SEN (DTCT)	When outside of vehicle is bright	3.1 V or more *
	When outside of vehicle is dark	0.6 V or less

\*:Outside light varies. The value may be less than the standard value if brightness is weak.

##### Is the inspection result normal?

- YES >> Optical sensor is normal.  
NO >> Refer to [EXL-124, "Diagnosis Procedure"](#).

### Diagnosis Procedure

INFOID:000000009175385

Regarding Wiring Diagram information, refer to [EXL-40, "Wiring Diagram"](#).

#### 1.CHECK OPTICAL SENSOR POWER SUPPLY INPUT

1. Turn ignition switch ON.
2. Turn lighting switch AUTO.
3. Check voltage between optical sensor harness connector and ground.

(+)		(-)	Voltage (Approx.)
Optical sensor			
Connector	Terminal	Ground	5 V
M15	1		

##### Is the inspection result normal?

- YES >> GO TO 2.  
NO >> GO TO 4.

#### 2.CHECK OPTICAL SENSOR GROUND INPUT

Check voltage between optical sensor harness connector and ground.

(+)		(-)	Voltage (Approx.)
Optical sensor			
Connector	Terminal	Ground	0 V
M15	3		

##### Is the inspection result normal?

- YES >> GO TO 3.  
NO >> GO TO 6.

#### 3.CHECK OPTICAL SENSOR SIGNAL OUTPUT

With illuminating the optical sensor, check voltage between optical sensor harness connector and ground.

# OPTICAL SENSOR

## < DTC/CIRCUIT DIAGNOSIS >

(+)		(-)	Condition	Voltage (Approx.)	
Optical sensor					
Connector	Terminal				
M15	2	Ground	Optical sensor	When illuminating	3.1 V or more *
				When shutting off light	0.6 V or less

\*: Illuminate the optical sensor. The value may be less than the standard if brightness is weak.

### Is the inspection result normal?

YES >> GO TO 7.

NO >> Replace the optical sensor. Refer to [EXL-146. "Removal and Installation"](#).

## 4.CHECK OPTICAL SENSOR OPEN CIRCUIT

1. Turn ignition switch OFF.
2. Disconnect optical sensor connector and BCM connector.
3. Check continuity between optical sensor harness connector and BCM harness connector.

Optical sensor		BCM		Continuity
Connector	Terminal	Connector	Terminal	
M15	1	M18	3	Yes

### Is the inspection result normal?

YES >> GO TO 5.

NO >> Repair or replace the harness or connector.

## 5.CHECK OPTICAL SENSOR SHORT CIRCUIT

Check continuity between optical sensor harness connector and ground.

Optical sensor		Ground	Continuity
Connector	Terminal		
M15	1		No

### Is the inspection result normal?

YES >> Replace BCM. Refer to [BCS-80. "Removal and Installation"](#).

NO >> Repair or replace the harness or connector.

## 6.CHECK OPTICAL SENSOR GROUND OPEN CIRCUIT

1. Turn ignition switch OFF.
2. Disconnect optical sensor connector and BCM connector.
3. Check continuity between optical sensor harness connector and BCM harness connector.

Optical sensor		BCM		Continuity
Connector	Terminal	Connector	Terminal	
M15	3	M18	17	Yes

### Is the inspection result normal?

YES >> Replace BCM. Refer to [BCS-80. "Removal and Installation"](#).

NO >> Repair or replace the harness or connector.

## 7.CHECK OPTICAL SENSOR SIGNAL OPEN CIRCUIT

1. Turn ignition switch OFF.
2. Disconnect optical sensor connector and BCM connector.
3. Check continuity between optical sensor harness connector and BCM harness connector.

## OPTICAL SENSOR

### < DTC/CIRCUIT DIAGNOSIS >

Optical sensor		BCM		Continuity
Connector	Terminal	Connector	Terminal	
M15	2	M18	4	Yes

Is the inspection result normal?

YES >> GO TO 8.

NO >> Repair or replace the harness or connector.

### 8. CHECK OPTICAL SENSOR SHORT CIRCUIT

Check continuity between optical sensor harness connector and ground.

Optical sensor		Ground	Continuity
Connector	Terminal		
M15	2		No

Is the inspection result normal?

YES >> Replace BCM. Refer to [BCS-80, "Removal and Installation"](#).

NO >> Repair or replace the harness or connector.

# HAZARD SWITCH

< DTC/CIRCUIT DIAGNOSIS >

## HAZARD SWITCH

### Component Function Check

INFOID:000000009175386

#### 1. CHECK HAZARD SWITCH SIGNAL BY CONSULT

##### CONSULT DATA MONITOR

1. Turn ignition switch ON.
2. Select HAZARD SW of BCM (FLASHER) DATA MONITOR item.
3. While operating the hazard switch, check the monitor status.

Monitor item	Condition		Monitor status
HAZARD SW	Hazard switch	ON	On
		OFF	Off

Is the inspection result normal?

- YES >> Hazard switch circuit is normal.  
 NO >> Refer to [EXL-127, "Diagnosis Procedure"](#).

### Diagnosis Procedure

INFOID:000000009175387

Regarding Wiring Diagram information, refer to [EXL-56, "Wiring Diagram"](#).

#### 1. CHECK HAZARD SWITCH SIGNAL INPUT

1. Turn ignition switch OFF.
2. Disconnect hazard switch harness connector M26.
3. Turn ignition switch ON.
4. Check voltage between hazard switch harness connector M26 and ground.

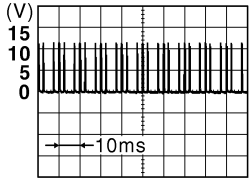
(+)		(-)	Voltage (Approx.)
Hazard switch			
Connector	Terminal		
M26	2	Ground	 <p style="text-align: right;">JPMAI0154GB</p>

Is the inspection result normal?

- YES >> GO TO 4.  
 NO >> GO TO 2.

#### 2. CHECK HAZARD SWITCH SIGNAL OPEN CIRCUIT

1. Turn ignition switch OFF.
2. Disconnect BCM harness connector M18.
3. Check continuity between hazard switch harness connector and BCM harness connector.

Hazard switch		BCM		Continuity
Connector	Terminal	Connector	Terminal	
M26	2	M18	36	Yes

Is the inspection result normal?

- YES >> GO TO 3.  
 NO >> Repair or replace the harness or connector.

A  
B  
C  
D  
E  
F  
G  
H  
I  
J  
K  
L  
M  
N  
O  
P

EXL

# HAZARD SWITCH

< DTC/CIRCUIT DIAGNOSIS >

## 3. CHECK HAZARD SWITCH SIGNAL SHORT CIRCUIT

Check continuity between hazard switch harness connector and ground.

Hazard switch		Ground	Continuity
Connector	Terminal		
M26	2		No

Is the inspection result normal?

YES >> Replace BCM. Refer to [BCS-80, "Removal and Installation"](#).

NO >> Repair or replace the harness or connector.

## 4. CHECK HAZARD SWITCH GROUND OPEN CIRCUIT

Check continuity between hazard switch harness connector and ground.

Hazard switch		Ground	Continuity
Connector	Terminal		
M26	3		Yes

Is the inspection result normal?

YES >> Replace hazard switch. Refer to [EXL-148, "Removal and Installation"](#).

NO >> Repair or replace the harness or connectors.



# EXTERIOR LIGHTING SYSTEM SYMPTOMS

< SYMPTOM DIAGNOSIS >

## SYMPTOM DIAGNOSIS

### EXTERIOR LIGHTING SYSTEM SYMPTOMS

#### Symptom Table

INFOID:000000009175388

**CAUTION:**

Perform the self-diagnosis with **CONSULT** before the symptom diagnosis. Perform the trouble diagnosis if any DTC is detected.

Symptom		Possible cause	Inspection item
Headlamp does not switch to the high beam.	One side	<ul style="list-style-type: none"> <li>• Fuse</li> <li>• Harness between IPDM E/R and the front combination lamp</li> <li>• Harness between the front combination lamp and ground</li> </ul>	Headlamp (HI) circuit Refer to <a href="#">EXL-108</a> .
	Both sides	—	<b>Symptom diagnosis</b> BOTH SIDE HEADLAMPS DO NOT SWITCH TO HIGH BEAM Refer to <a href="#">EXL-132</a> .
High beam indicator lamp is not turned ON (Headlamp switched to the high beam).		<ul style="list-style-type: none"> <li>• BCM</li> <li>• Combination meter</li> </ul>	<ul style="list-style-type: none"> <li>• Combination meter Data monitor HI-BEAM IND</li> <li>• BCM (HEAD LAMP) Active test "HEADLAMP"</li> </ul>
Headlamp does not switch to the low beam.		<ul style="list-style-type: none"> <li>• Combination switch (lighting and turn signal switch)</li> <li>• Harness between the combination switch and BCM</li> <li>• BCM</li> <li>• IPDM E/R</li> </ul>	Combination switch (lighting and turn signal switch) Refer to <a href="#">BCS-79</a> .
		High beam request signal	IPDM E/R Data monitor HL HI REQ
Headlamp does not turn ON.	One side	<ul style="list-style-type: none"> <li>• Fuse</li> <li>• Harness between IPDM E/R and the front combination lamp</li> <li>• Front combination lamp</li> <li>• Harness between the front combination lamp and ground</li> </ul>	Headlamp (LO) circuit Refer to <a href="#">EXL-110</a> .
	Both sides	—	<b>Symptom diagnosis</b> BOTH SIDE HEADLAMPS (LO) ARE NOT TURNED ON Refer to <a href="#">EXL-133</a> .
Headlamp does not turn OFF.	When the ignition switch is turned ON	<ul style="list-style-type: none"> <li>• BCM</li> <li>• Combination switch (lighting and turn signal switch)</li> </ul>	Combination switch (lighting and turn signal switch) Refer to <a href="#">BCS-79</a> .
	The ignition switch is turned OFF (After activating the battery saver).	IPDM E/R	—
Headlamp is not turned ON/OFF with lighting switch AUTO.		<ul style="list-style-type: none"> <li>• Combination switch (lighting and turn signal switch)</li> <li>• Harness between combination switch and BCM</li> <li>• BCM</li> </ul>	Combination switch Refer to <a href="#">BCS-79</a> .
		<ul style="list-style-type: none"> <li>• Optical sensor</li> <li>• Harness between optical sensor and BCM</li> <li>• BCM</li> </ul>	Optical sensor Refer to <a href="#">EXL-124</a> .

## EXTERIOR LIGHTING SYSTEM SYMPTOMS

### < SYMPTOM DIAGNOSIS >

Symptom	Possible cause	Inspection item	
Daytime light system does not activate. (if equipped)	<ul style="list-style-type: none"> <li>• Fuse</li> <li>• Harness between IPDM E/R and the daytime light relay</li> <li>• Harness between daytime light relay and the daytime lamp</li> <li>• Harness between the daytime lamp and ground</li> <li>• Daytime light bulb</li> <li>• IPDM E/R</li> <li>• Daytime light relay</li> <li>• BCM</li> </ul>	<p><b>Symptom diagnosis</b> Daytime light system inoperative. Refer to <a href="#">EXL-136</a>.</p>	
Front fog lamp is not turned ON.	One side	<ul style="list-style-type: none"> <li>• Front fog lamp bulb</li> <li>• Harness between IPDM E/R and front fog lamp</li> <li>• Front fog lamp</li> <li>• IPDM E/R</li> </ul>	Front fog lamp circuit Refer to <a href="#">EXL-115</a> .
	Both sides	—	<p><b>Symptom diagnosis</b> BOTH SIDE FRONT FOG LAMPS ARE NOT TURNED ON Refer to <a href="#">EXL-115</a>.</p>
Parking lamp is not turned ON.	One side	<ul style="list-style-type: none"> <li>• Parking lamp bulb</li> <li>• Harness between IPDM E/R and front/rear combination lamp</li> <li>• Harness between front/rear combination lamp and ground</li> <li>• Front/rear combination lamp</li> <li>• IPDM E/R</li> </ul>	Parking lamp circuit Refer to <a href="#">EXL-117</a> .
	Both sides	—	<p><b>Symptom diagnosis</b> PARKING, LICENSE PLATE AND TAIL LAMPS ARE NOT TURNED ON Refer to <a href="#">EXL-134</a>.</p>
Turn signal lamp does not blink.	Indicator lamp is normal. (The applicable side performs the high flasher activation).	<ul style="list-style-type: none"> <li>• Hazard BCM and each turn signal lamp</li> <li>• Turn signal lamp bulb</li> </ul>	Turn signal lamp circuit Refer to <a href="#">EXL-121</a> .
Turn signal indicator lamp does not blink.	One side	Combination meter	—
	Both sides (Always)	<ul style="list-style-type: none"> <li>• Turn signal indicator lamp signal</li> <li>- BCM</li> <li>• Combination meter</li> </ul>	<ul style="list-style-type: none"> <li>• Combination meter</li> <li>Data monitor TURN IND</li> <li>• BCM (FLASHER)</li> <li>Active test FLASHER</li> </ul>
	Both sides (Does blink when activating hazard warning lamp with the ignition switch OFF)	<ul style="list-style-type: none"> <li>• Combination meter power supply and ground circuit</li> <li>• Combination meter</li> </ul>	Combination meter Power supply and ground circuit Refer to <a href="#">MWI-59</a> .
<ul style="list-style-type: none"> <li>• Hazard warning lamp does not activate.</li> <li>• Hazard warning lamp continues activating (Turn signal is normal).</li> </ul>	<ul style="list-style-type: none"> <li>• Hazard switch</li> <li>• Harness between the hazard switch and BCM</li> <li>• BCM</li> </ul>	Hazard switch Refer to <a href="#">EXL-127</a> .	

# NORMAL OPERATING CONDITION

< SYMPTOM DIAGNOSIS >

## NORMAL OPERATING CONDITION

---

### Description

INFOID:000000009175389

#### AUTO LIGHT SYSTEM

The headlamp may not be turned ON/OFF immediately after passing dark area or bright area (short tunnel, sky bridge, shadowed area etc.) while using the auto light system. This causes for the control difference. This is normal.

- A
- B
- C
- D
- E
- F
- G
- H
- I
- J
- K
- EXL
- M
- N
- O
- P

# BOTH SIDE HEADLAMPS DO NOT SWITCH TO HIGH BEAM

< SYMPTOM DIAGNOSIS >

## BOTH SIDE HEADLAMPS DO NOT SWITCH TO HIGH BEAM

### Description

INFOID:000000009175390

The headlamps (both sides) do not switch to high beam when the lighting switch is in the HI or PASS setting.

### Diagnosis Procedure

INFOID:000000009175391

#### 1.COMBINATION SWITCH (LIGHTING AND TURN SIGNAL SWITCH) INSPECTION

Check the combination switch (lighting and turn signal switch). Refer to [BCS-79, "Symptom Table"](#).

Is the inspection result normal?

- YES >> GO TO 2.
- NO >> Repair or replace the malfunctioning part.

#### 2.CHECK HEADLAMP (HI) REQUEST SIGNAL INPUT

##### ⓅCONSULT DATA MONITOR

1. Select HL HI REQ of IPDM E/R DATA MONITOR item.
2. While operating the lighting switch, check the monitor status.

Monitor item	Condition		Monitor status
HL HI REQ	Lighting switch position	HI or PASS	ON
		Except for HI or PASS	OFF

Is the inspection results normal?

- YES >> GO TO 3.
- NO >> Replace BCM. Refer to [BCS-80, "Removal and Installation"](#).

#### 3.HEADLAMP (HI) CIRCUIT INSPECTION

Check the headlamp (HI) circuit. Refer to [EXL-108, "Diagnosis Procedure"](#).

Is the inspection results normal?

- YES >> Replace IPDM E/R. Refer to [PCS-32, "Removal and Installation"](#).
- NO >> Repair or replace the malfunctioning part.

# BOTH SIDE HEADLAMPS (LO) ARE NOT TURNED ON

< SYMPTOM DIAGNOSIS >

## BOTH SIDE HEADLAMPS (LO) ARE NOT TURNED ON

### Description

INFOID:000000009175392

The headlamps (both sides) do not turn ON in any lighting switch setting.

### Diagnosis Procedure

INFOID:000000009175393

#### 1. CHECK COMBINATION SWITCH (LIGHTING AND TURN SIGNAL SWITCH)

Check the combination switch (lighting and turn signal switch). Refer to [BCS-79, "Symptom Table"](#).

Is the inspection results normal?

YES >> GO TO 2.

NO >> Repair or replace the malfunctioning part.

#### 2. CHECK HEADLAMP (LO) REQUEST SIGNAL INPUT

 CONSULT DATA MONITOR

1. Select HL LO REQ of IPDM E/R DATA MONITOR item.
2. While operating the lighting switch, check the monitor status.

Monitor item	Condition	Monitor status
HL LO REQ	Lighting switch position	Headlamp ON
		OFF

Is the inspection results normal?

YES >> GO TO 3.

NO >> Replace BCM. Refer to [BCS-80, "Removal and Installation"](#).

#### 3. HEADLAMP (LO) CIRCUIT INSPECTION

Check the headlamp (LO) circuit. Refer to [EXL-110, "Diagnosis Procedure"](#).

Is the inspection results normal?

YES >> Replace IPDM E/R. Refer to [PCS-32, "Removal and Installation"](#).

NO >> Repair or replace the malfunctioning part.

A  
B  
C  
D  
E  
F  
G  
H  
I  
J  
K  
M  
N  
O  
P

EXL

# PARKING, LICENSE PLATE, SIDE MARKER AND TAIL LAMPS ARE NOT TURNED ON

< SYMPTOM DIAGNOSIS >

## PARKING, LICENSE PLATE, SIDE MARKER AND TAIL LAMPS ARE NOT TURNED ON

### Description

INFOID:000000009175394

The parking, license plate, tail lamps and side marker lamps do not turn ON with the combination switch in any setting.

### Diagnosis Procedure

INFOID:000000009175395

#### 1.COMBINATION SWITCH (LIGHTING AND TURN SIGNAL SWITCH) INSPECTION

Check the combination switch (lighting and turn signal switch). Refer to [BCS-79. "Symptom Table"](#).

Is the inspection results normal?

- YES >> GO TO 2.
- NO >> Repair or replace the malfunctioning part.

#### 2.CHECK TAIL LAMP RELAY REQUEST SIGNAL INPUT

##### ④CONSULT DATA MONITOR

1. Select TAIL & CLR REQ of IPDM E/R DATA MONITOR item.
2. While operating the lighting switch, check the monitor status.

Monitor item	Condition		Monitor status
TAIL&CLR REQ	Lighting switch position	Parking lamp	ON
		OFF	OFF

Is the inspection results normal?

- YES >> GO TO 3.
- NO >> Replace BCM. Refer to [BCS-80. "Removal and Installation"](#).

#### 3.PARK LAMP CIRCUIT INSPECTION

Check the parking lamp circuit. Refer to [EXL-117. "Diagnosis Procedure"](#).

Is the inspection results normal?

- YES >> Replace IPDM E/R. Refer to [PCS-32. "Removal and Installation"](#).
- NO >> Repair or replace the malfunctioning part.

# BOTH SIDE FRONT FOG LAMPS ARE NOT TURNED ON

< SYMPTOM DIAGNOSIS >

## BOTH SIDE FRONT FOG LAMPS ARE NOT TURNED ON

### Description

INFOID:000000009175396

The front fog lamps do not turn ON in any setting.

### Diagnosis Procedure

INFOID:000000009175397

#### 1.COMBINATION SWITCH (LIGHTING AND TURN SIGNAL SWITCH) INSPECTION

Check the combination switch (lighting and turn signal switch). Refer to [BCS-79, "Symptom Table"](#).

Is the inspection results normal?

YES >> GO TO 2.

NO >> Repair or replace the malfunctioning part.

#### 2.CHECK FRONT FOG LAMP REQUEST SIGNAL INPUT

Ⓜ WITH CONSULT DATA MONITOR

1. Select FR FOG REQ of IPDM E/R DATA MONITOR item.
2. While operating the front fog lamp switch, check the monitor status.

Monitor item	Condition	Monitor status
FR FOG REQ	Lighting switch position	ON
		OFF

Is the inspection results normal?

YES >> GO TO 3.

NO >> Replace BCM. Refer to [BCS-80, "Removal and Installation"](#).

#### 3.FRONT FOG LAMP CIRCUIT INSPECTION

Check the front fog lamp circuit. Refer to [EXL-115, "Diagnosis Procedure"](#).

Is the inspection results normal?

YES >> Replace IPDM E/R. Refer to [PCS-32, "Removal and Installation"](#).

NO >> Repair or replace the malfunctioning part.

A  
B  
C  
D  
E  
F  
G  
H  
I  
J  
K  
M  
N  
O  
P

EXL

# DAYTIME LIGHT SYSTEM INOPERATIVE

< SYMPTOM DIAGNOSIS >

## DAYTIME LIGHT SYSTEM INOPERATIVE

### Description

INFOID:000000009175398

The daytime light system is inoperative even though the combination switch (lighting and turn signal switch) and parking brake switch are in the normal setting, also whenever the engine is operating.

### Diagnosis Procedure

INFOID:000000009175399

#### 1. CHECK DAYTIME LIGHT OPERATION

1. Perform BCM(HEADLAMP) DAYTIME RUNNING LIGHT active test. Refer to [BCS-18. "HEADLAMP : CONSULT Function \(BCM - HEADLAMP\)".](#)
2. Check that the daytime lights turn on.

Is the inspection results normal?

- YES >> Replace BCM. Refer to [BCS-80. "Removal and Installation".](#)  
NO >> GO TO 2.

#### 2. CHECK DAYTIME LIGHT RELAY FUSE

1. Turn ignition switch OFF.
2. Check that the following fuse is not blown.

Unit	Fuse No.	Capacity
Daytime light	43	10 A

Is the inspection result normal?

- YES >> GO TO 3.  
NO >> Replace the blown fuse after repairing the affected circuit.

#### 3. CHECK DAYTIME LIGHT BULBS

Check that the daytime light bulbs are not open.

Is the inspection result normal?

- YES >> GO TO 4.  
NO >> Replace the bulbs.

#### 4. PERFORM DAYTIME LIGHT CIRCUIT INSPECTION

Check the daytime light circuit. Refer to [EXL-112. "Diagnosis Procedure".](#)

Is the inspection results normal?

- YES >> Replace IPDM E/R. Refer to [PCS-32. "Removal and Installation".](#)  
NO >> Repair or replace the malfunctioning part.



# HEADLAMP

< PERIODIC MAINTENANCE >

## PERIODIC MAINTENANCE

### HEADLAMP

#### Inspection

INFOID:000000009175400

#### PREPARATION BEFORE ADJUSTING

Before performing aiming adjustment, check the following:

- Ensure all tires are inflated to correct pressure.
- Place vehicle and screen on level surface.
- Ensure there is no load in vehicle other than the driver (or equivalent weight placed in driver's position).
- Coolant and engine oil filled to correct level, and fuel tank full.
- Remove cargo and/or luggage to maintain an unloaded vehicle condition.
- Confirm spare tire, jack and tools are properly stowed.
- Carefully wipe off any dirt from headlamp lens.

#### CAUTION:

**Do not use organic solvent (thinner, gasoline etc.)**

- Place a driver or equivalent weight of 68.5 kg (150 lb) on the driver seat.
- By hand, bounce the front and rear of the vehicle to settle the suspension and eliminate any static load.
- Place the front tires in the straight ahead position.
- Aim each headlamp individually and ensure other headlamp beam pattern is blocked from screen.

#### NOTE:

- For headlamp aiming details, refer to regulations in your area.
- By regulation, no means for horizontal aim adjustment is provided from the factory; only vertical aim is adjustable.
- Use adjusting screw to perform aiming adjustment.
- Perform headlamp aiming if:
  - The vehicle front body has been repaired.
  - The front combination lamp has been removed or replaced.
  - Any outfitting has been installed.
  - The vehicle's standard load condition has been substantially increased.

#### AIMING ADJUSTMENT SCREW

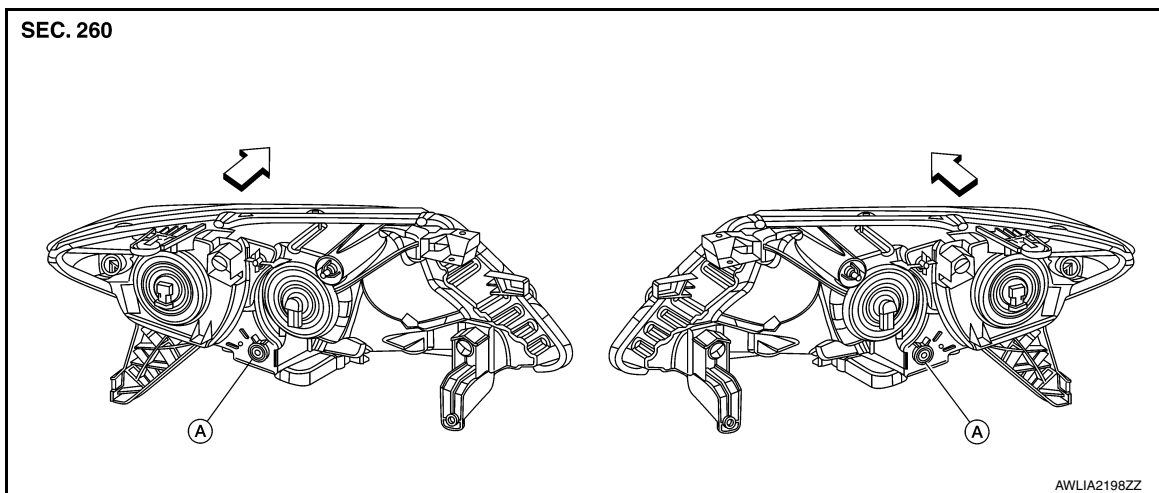

- A. Headlamp HI/LO (UP/DOWN) ← Front adjustment screw

# HEADLAMP

< PERIODIC MAINTENANCE >

## Aiming Adjustment Procedure

INFOID:000000009175401

Aiming Chart

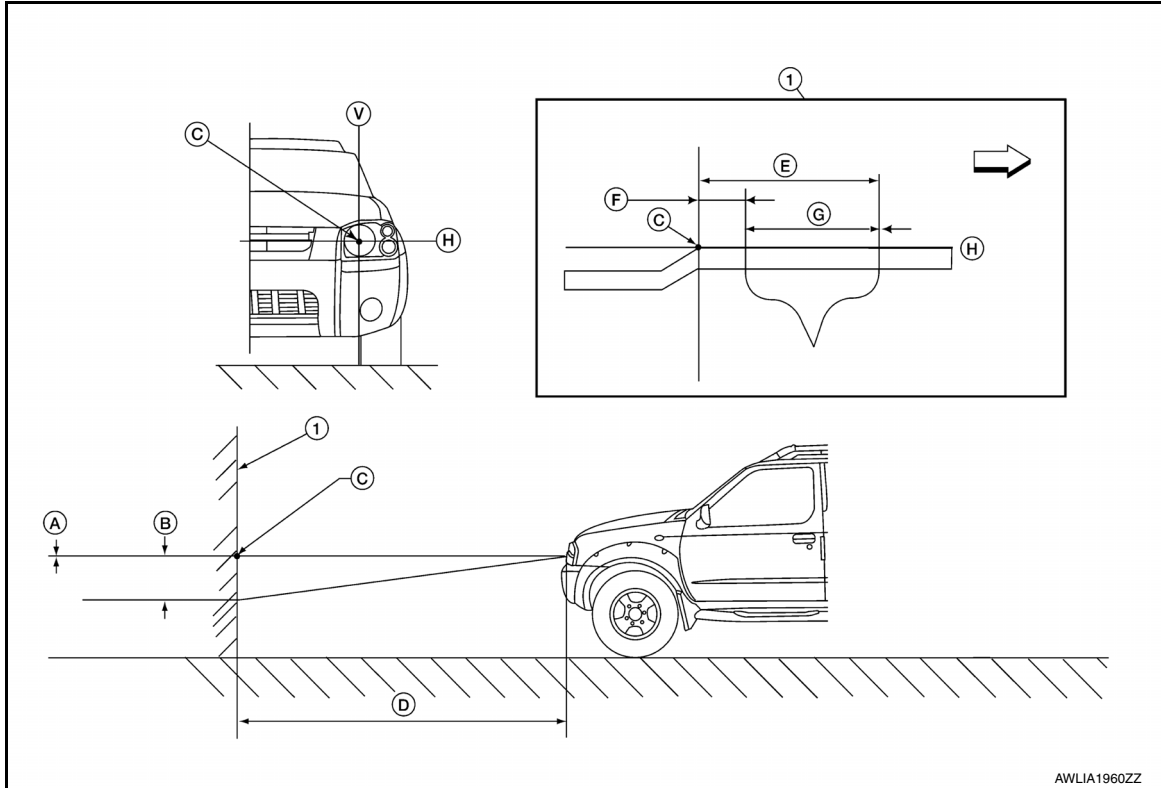

- |   |   |   |
|---|---|---|
| 1. Adjustment screen  | A. Highest cutoff line height                                     | B. Lowest cutoff line height  |
| C. Headlamp bulb center (H-V point)   | D. Distance of headlamp aiming screen from vehicle 7.62 m (25 ft) | E. Maximum aim evaluation distance from vertical center on aiming screen 399 mm (3°R) |
| F. Minimum aim evaluation distance from vertical center on aiming screen 133 mm (1°R) | G. Aim evaluation area  | H. Horizontal aiming evaluation line  |
| V. Vertical aiming evaluation line  | ↔ Right   |   |

**A (Highest cutoff line height)**

**-13.3 mm (-0.5 in)**

**0.1° up**

**B (Lowest cutoff line height)**

**53.2 mm (2.1 in)**

**0.4° down**

### LOW BEAM AND HIGH BEAM

#### NOTE:

- Basic illuminating area for evaluation and/or adjustment should be within range shown on aiming chart.

- Use adjustment screw to perform aiming adjustment.
  - Ensure fog lamps (if equipped) are turned off.
- Block the opposite headlamp from projecting a beam pattern onto the adjustment screen, using a suitable object. Aim each headlamp individually.

#### CAUTION:

**Do not cover the lens surface with tape etc. The lens is made of resin.**

- Place the screen on the same level and flat surface as the vehicle.

#### NOTE:

- Surface should be free of any debris that would cause a difference between the headlamp center and the adjustment screen.
- Face the front of the vehicle to the screen and measure distance between the headlamp center and the screen surface.

# HEADLAMP

< PERIODIC MAINTENANCE >

---

**Distance (D) between the headlamp center and the screen : 7.62 m (25 ft)**

5. Start the engine and turn the headlamp on.
6. Determine the preferred vertical aim range dimensions, using the aiming chart.
7. Measure the projected beam within the aim evaluation segment on the screen.
8. Adjust the beam pattern of each headlamp until the aim evaluation segment (the area relative to both the highest and lowest cutoff line height) is positioned within the vertical aim range dimensions shown on the aiming chart.

A  
B  
C  
D  
E  
F  
G  
H  
I  
J  
K  
EXL  
M  
N  
O  
P

# FRONT FOG LAMP AIMING ADJUSTMENT

< PERIODIC MAINTENANCE >

## FRONT FOG LAMP AIMING ADJUSTMENT

### Aiming Adjustment

INFOID:000000009175402

#### NOTE:

Check the following conditions before performing the aiming adjustment.

- Keep all tires inflated to correct pressure.
- Place vehicle on level ground.
- See that vehicle is unloaded (except for full levels of coolant, engine oil and fuel, and spare tire, jack, and tools). Have the driver or equivalent weight placed in driver seat.
- When performing adjustment, if necessary, cover the headlamps and opposite fog lamp.

1. Set the distance between the screen and the center of the fog lamp lens as shown.

- (1) Aiming screen or a matte white surface
- (2) 7.62 m (25 ft)
- (3) Floor to center of fog lamp lens
- (4) Floor

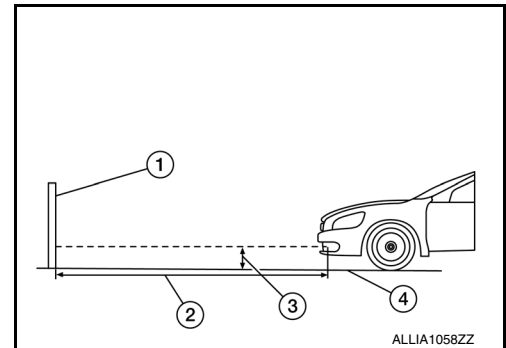

2. Turn front fog lamps ON.

3. Access adjustment screw from underneath front bumper. Use a suitable tool to adjust. Turn screw clockwise to raise pattern and counterclockwise to lower pattern. Adjust front fog lamps using adjusting screw so that the top edge of the high intensity zone is 100 mm (4 in) below the height of the fog lamp centers as shown.

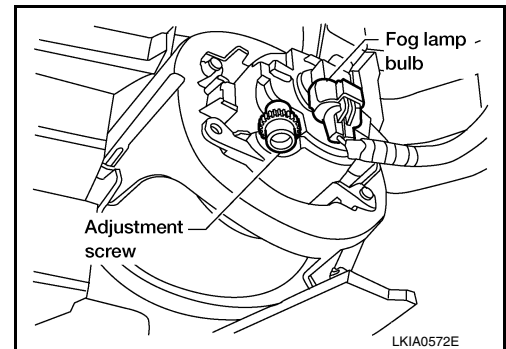

- (1) Vertical center line of left fog lamp.
- (2) Lamp center above ground.
- (3) 100 mm (4 in) (0.76 deg) below lamp center above ground.
- (4) Left fog lamp high intensity area.
- (5) Vehicle center axis.
- (6) Vertical center line of right fog lamp.
- (7) Right fog lamp high intensity area.

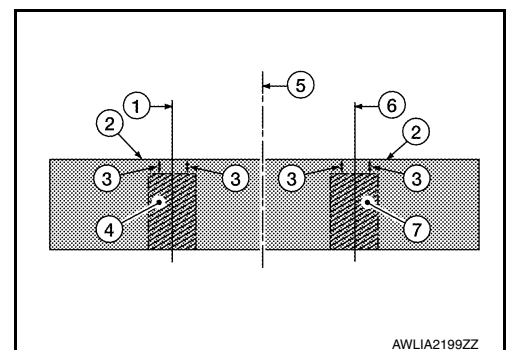

# FRONT COMBINATION LAMP

< REMOVAL AND INSTALLATION >

## REMOVAL AND INSTALLATION

### FRONT COMBINATION LAMP

Exploded View

INFOID:000000009175403

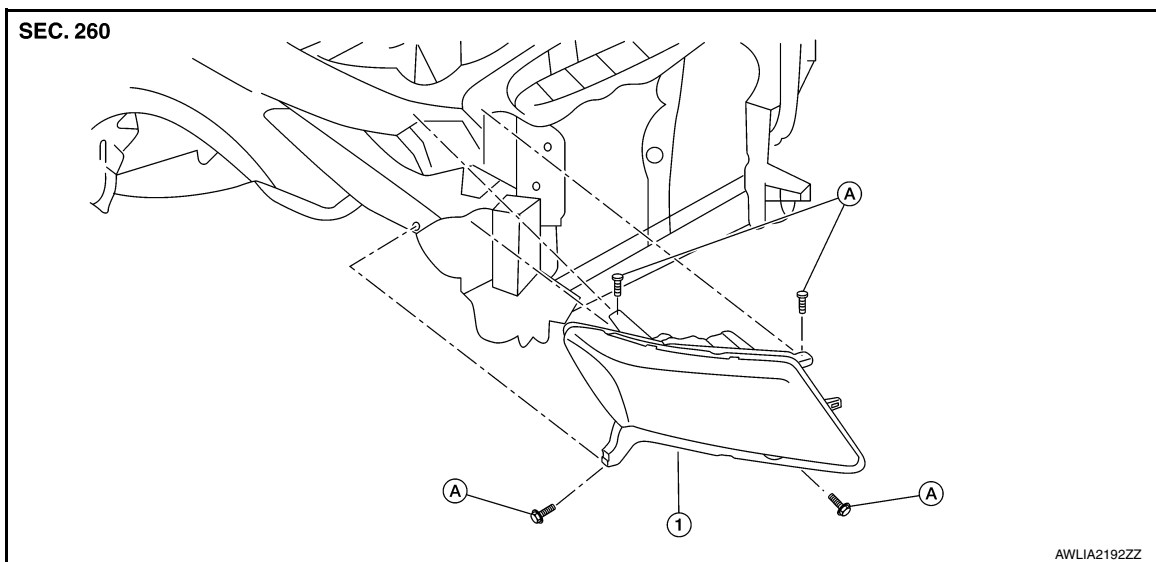

1. Front combination lamp

A. Bolt

### Removal and Installation

INFOID:000000009175404

#### FRONT COMBINATION LAMP

##### Removal

1. Disconnect the battery negative terminal. Refer to [PG-90. "Removal and Installation"](#).
2. Release the clips and pawls using a suitable tool and remove hoodledge finisher.
3. Release front under cover clips and remove front under cover.
4. Remove front bumper fascia. Refer to [EXT-17. "Removal and Installation"](#).
5. Remove washer tank. Refer to [WW-54. "Removal and Installation"](#).
6. Remove front combination lamp bolts.
7. Pull front combination lamp forward.
8. Disconnect the harness connectors from the front combination lamp.

##### Installation

Installation is in the reverse order of removal.

##### **CAUTION:**

**After installation, perform headlamp aiming adjustment. Refer to [EXL-138. "Aiming Adjustment Procedure"](#).**

#### HALOGEN BULB (LOW BEAM)

##### **WARNING:**

**Do not touch bulb by hand while it is lit or right after being turned off. Burning may result.**

##### **CAUTION:**

- Do not touch glass surface of the bulb with bare hands or allow oil or grease to get on it to prevent damage to bulb.
- Do not leave the bulb out of the lamp reflector for a long time because dust, moisture, smoke, etc. may affect the performance of the lamp.

##### Removal

1. Rotate low beam bulb counterclockwise and remove.

## FRONT COMBINATION LAMP

### < REMOVAL AND INSTALLATION >

---

2. Disconnect the harness connector from the low beam bulb.

#### Installation

Installation is in the reverse order of removal.

#### HALOGEN BULB (HIGH BEAM)

##### **WARNING:**

**Do not touch bulb by hand while it is lit or right after being turned off. Burning may result.**

##### **CAUTION:**

- **Do not touch glass surface of the bulb with bare hands or allow oil or grease to get on it to prevent damage to bulb.**
- **Do not leave the bulb out of the lamp reflector for a long time because dust, moisture, smoke, etc. may affect the performance of the lamp.**

#### Removal

1. Rotate high beam bulb counterclockwise and remove.
2. Disconnect the harness connector from the high beam bulb.

#### Installation

Installation is in the reverse order of removal.

#### PARKING LAMP BULB

##### **WARNING:**

**Do not touch bulb by hand while it is lit or right after being turned off. Burning may result.**

##### **CAUTION:**

- **Do not touch glass surface of the bulb with bare hands or allow oil or grease to get on it to prevent damage to bulb.**
- **Do not leave the bulb out of the lamp reflector for a long time because dust, moisture, smoke, etc. may affect the performance of the lamp.**

#### Removal

1. Release the clips and pawls using a suitable tool and remove hoodledge finisher.
2. Remove washer tank. Refer to [WW-54, "Removal and Installation"](#).
3. Rotate parking lamp socket counterclockwise and remove.
4. Remove parking lamp bulb from the bulb socket.

#### Installation

Installation is in the reverse order of removal.

##### **CAUTION:**

**After installing, be sure to install the bulb socket securely to ensure watertightness.**

#### FRONT TURN SIGNAL LAMP BULB

##### **WARNING:**

**Do not touch bulb by hand while it is lit or right after being turned off. Burning may result.**

##### **CAUTION:**

- **Do not touch glass surface of the bulb with bare hands or allow oil or grease to get on it to prevent damage to bulb.**
- **Do not leave the bulb out of the lamp reflector for a long time because dust, moisture, smoke, etc. may affect the performance of the lamp.**

#### Removal

1. Release the clips and pawls using a suitable tool and remove hoodledge finisher.
2. Rotate front turn signal lamp socket counterclockwise and remove.
3. Remove front turn signal lamp bulb from the bulb socket.

#### Installation

Installation is in the reverse order of removal.

##### **CAUTION:**

**After installing, be sure to install the bulb socket securely to ensure watertightness.**

#### FRONT SIDE MARKER LAMP BULB

##### **WARNING:**

# FRONT COMBINATION LAMP

## < REMOVAL AND INSTALLATION >

**Do not touch bulb by hand while it is lit or right after being turned off. Burning may result.**

**CAUTION:**

- **Do not touch glass surface of the bulb with bare hands or allow oil or grease to get on it to prevent damage to bulb.**
- **Do not leave the bulb out of the lamp reflector for a long time because dust, moisture, smoke, etc. may affect the performance of the lamp.**

### Removal

1. Release the clips and pawls using a suitable tool and remove hoodledge finisher.
2. Remove washer tank. Refer to [WW-54, "Removal and Installation"](#) .
3. Rotate front side marker lamp socket counterclockwise and remove.
4. Remove front side marker lamp bulb from the bulb socket.

### Installation

Installation is in the reverse order of removal.

**CAUTION:**

**After installing, be sure to install the bulb socket securely to ensure watertightness.**

A  
B  
C  
D  
E  
F  
G  
H  
I  
J  
K  
M  
N  
O  
P

EXL

# FRONT FOG LAMP

< REMOVAL AND INSTALLATION >

## FRONT FOG LAMP

Exploded View

INFOID:000000009175405

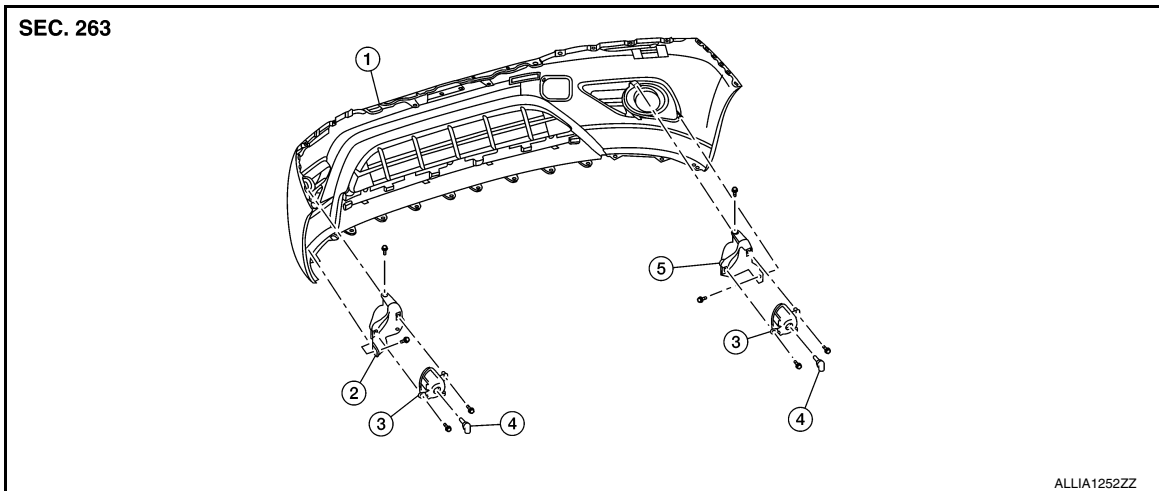

- |                        |                                |                           |
|------------------------|--------------------------------|---------------------------|
| 1. Front bumper fascia | 2. Front fog lamp bracket (LH) | 3. Front fog lamp (LH/RH) |
| 4. Front fog lamp bulb | 5. Front fog lamp bracket (RH) | A. Bolts                  |

## Removal and Installation

INFOID:000000009175406

### FRONT FOG LAMP

#### Removal

1. Partially remove the fender protector. Refer to [EXT-28, "FENDER PROTECTOR : Removal and Installation"](#).
2. Disconnect the harness connector(s) from the front fog lamp and daytime running lamp (if equipped).
3. Remove bolts and front fog lamp.

#### Installation

Installation in the reverse order of removal.

#### **CAUTION:**

**After installation, perform fog lamp aiming adjustment. Refer to [EXL-140, "Aiming Adjustment"](#).**

### FRONT FOG LAMP BULB

#### **WARNING:**

**Do not touch bulb by hand while it is lit or right after being turned off. Burning may result.**

#### **CAUTION:**

- Do not touch glass surface of the bulb with bare hands or allow oil or grease to get on it to prevent damage to bulb.
- Do not leave the bulb out of the lamp reflector for a long time because dust, moisture, smoke, etc. may affect the performance of the lamp.

#### Removal

1. Partially remove the front fender protector. Refer to [EXT-28, "FENDER PROTECTOR : Removal and Installation"](#).



## FRONT FOG LAMP

### < REMOVAL AND INSTALLATION >

2. Disconnect the harness connector (A) from the front fog lamp.
3. Rotate bulb (1) counterclockwise and remove.

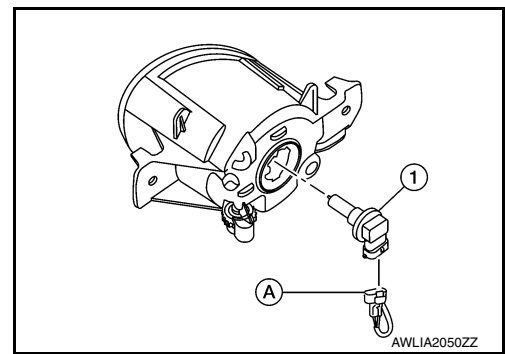

#### Installation

Installation is in the reverse order of removal.

### DAYTIME LAMP BULB (CANADA ONLY)

#### **WARNING:**

**Do not touch bulb by hand while it is lit or right after being turned off. Burning may result.**

#### **CAUTION:**

- Do not touch glass surface of the bulb with bare hands or allow oil or grease to get on it to prevent damage to bulb.
- Do not leave the bulb out of the lamp reflector for a long time because dust, moisture, smoke, etc. may affect the performance of the lamp.

#### Removal

1. Partially remove the front fender protector. Refer to [EXT-28. "FENDER PROTECTOR : Removal and Installation"](#).
2. Disconnect the harness connector (A) from the daytime lamp bulb (1).
3. Rotate bulb (1) counterclockwise and remove.

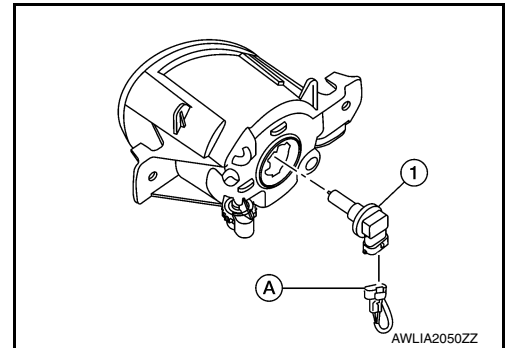

#### Installation

Installation is in the reverse order of removal.

A  
B  
C  
D  
E  
F  
G  
H  
I  
J  
K  
EXL  
M  
N  
O  
P

# OPTICAL SENSOR

< REMOVAL AND INSTALLATION >

## OPTICAL SENSOR

Exploded View

INFOID:000000009175407

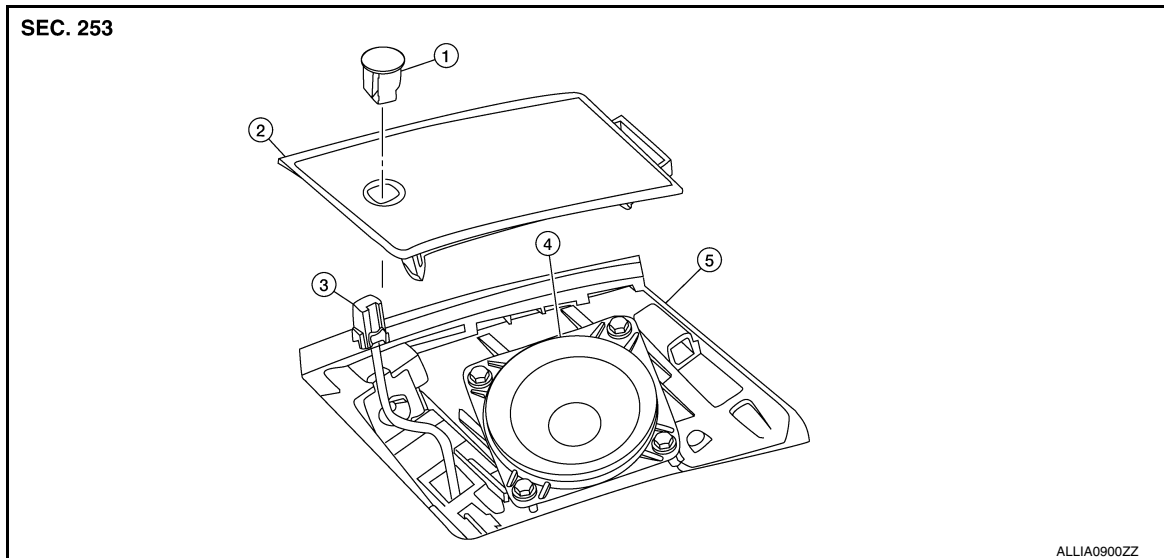

1. Optical sensor      2. Instrument panel tweeter grille (RH)      3. Optical sensor harness connector
4. Instrument panel tweeter (RH)      5. Instrument panel

## Removal and Installation

INFOID:000000009175408

### REMOVAL

1. Remove the instrument panel tweeter grille (RH) using a suitable tool.
2. Disconnect the harness connector from the optical sensor.
3. Release pawls and remove the optical sensor from the instrument panel tweeter grille (RH).

### INSTALLATION

Installation is in the reverse order of removal.

# LIGHTING & TURN SIGNAL SWITCH

< REMOVAL AND INSTALLATION >

---

## LIGHTING & TURN SIGNAL SWITCH

### Removal and Installation

INFOID:000000009175409

The lighting and turn signal switch is integrated into the combination switch and is replaced as an assembly. Refer to [BCS-81, "Removal and Installation"](#).

A  
B  
C  
D  
E  
F  
G  
H  
I  
J  
K  
EXL  
M  
N  
O  
P

# HAZARD SWITCH

< REMOVAL AND INSTALLATION >

## HAZARD SWITCH

### Removal and Installation

INFOID:000000009175410

#### REMOVAL

1. Remove cluster lid C. Refer to [IP-22. "CLUSTER LID C : Removal and Installation"](#).
2. Release the pawls (A) and remove the hazard switch (1) from cluster lid C (2).

:Pawl

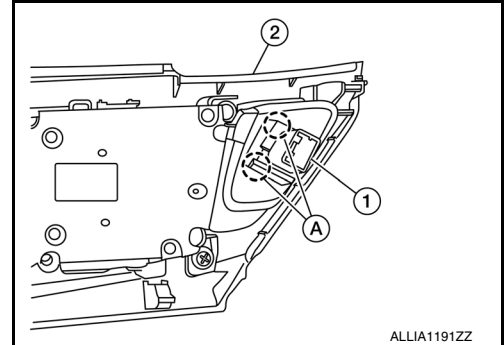

#### INSTALLATION

Installation is in the reverse order of removal.

# REAR COMBINATION LAMP

< REMOVAL AND INSTALLATION >

## REAR COMBINATION LAMP

### Exploded View

INFOID:000000009175411

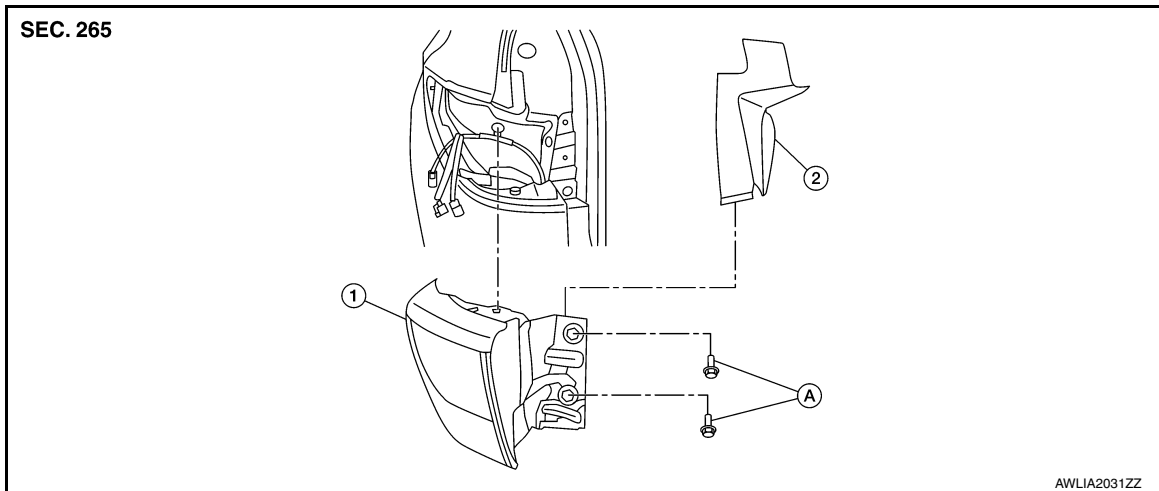

1. Rear combination lamp      2. Rear combination lamp bolt cover      A. Bolt

### Removal and Installation

INFOID:000000009175412

#### REAR COMBINATION LAMP

##### Removal

1. Release clips using a suitable tool and remove rear combination lamp bolt cover.
2. Remove rear combination lamp bolts.
3. Pull rear combination lamp rearward.
4. Disconnect the harness connector from the rear combination lamp and remove.

##### Installation

Installation is in the reverse order of removal.

#### REAR TURN SIGNAL LAMP BULB

##### **WARNING:**

**Do not touch bulb by hand while it is lit or right after being turned OFF. Burning may result.**

##### **CAUTION:**

- Do not touch glass surface of the bulb with bare hands or allow oil or grease to get on it to prevent damage to bulb.
- Do not leave the bulb out of the lamp reflector for a long time because dust, moisture, smoke, etc. may affect the performance of the lamp.

##### Removal

1. Remove the rear combination lamp. Refer to [EXL-149. "Removal and Installation"](#)
2. Rotate the rear turn signal lamp socket counterclockwise and remove.
3. Remove the bulb from rear turn signal bulb socket.

##### Installation

Installation is in the reverse order of removal.

#### STOP/TAIL LAMP BULB

##### **WARNING:**

**Do not touch bulb by hand while it is lit or right after being turned OFF. Burning may result.**

##### **CAUTION:**

- Do not touch glass surface of the bulb with bare hands or allow oil or grease to get on it to prevent damage to bulb.

A  
B  
C  
D  
E  
F  
G  
H  
I  
J  
K  
M  
N  
O  
P

EXL

## REAR COMBINATION LAMP

### < REMOVAL AND INSTALLATION >

---

- **Do not leave the bulb out of the lamp reflector for a long time because dust, moisture, smoke, etc. may affect the performance of the lamp.**

#### Removal

1. Remove the rear combination lamp. Refer to [EXL-149, "Removal and Installation"](#)
2. Rotate the stop/tail lamp socket counterclockwise and remove.
3. Remove the bulb from stop/tail lamp bulb socket.

#### Installation

Installation is in the reverse order of removal.

### SIDE MARKER LAMP BULB

#### **WARNING:**

**Do not touch bulb by hand while it is lit or right after being turned OFF. Burning may result.**

#### **CAUTION:**

- **Do not touch glass surface of the bulb with bare hands or allow oil or grease to get on it to prevent damage to bulb.**
- **Do not leave the bulb out of the lamp reflector for a long time because dust, moisture, smoke, etc. may affect the performance of the lamp.**

#### Removal

1. Remove the rear combination lamp. Refer to [EXL-149, "Removal and Installation"](#)
2. Rotate the side marker lamp socket counterclockwise and remove.
3. Remove the bulb from side marker bulb socket.

#### Installation

Installation is in the reverse order of removal.

# HIGH-MOUNTED STOP LAMP

< REMOVAL AND INSTALLATION >

## HIGH-MOUNTED STOP LAMP

### Removal and Installation

INFOID:000000009175413

#### REMOVAL

1. Remove rear spoiler. Refer to [EXT-41, "Removal and Installation"](#).

#### INSTALLATION

Installation is in the reverse order of removal.

#### HIGH-MOUNTED STOP LAMP BULB

The high-mounted stop lamp bulb is LED and is serviced as part of the high-mounted stop lamp. Refer to [EXL-151, "Removal and Installation"](#)

A  
B  
C  
D  
E  
F  
G  
H  
I  
J  
K  
EXL  
M  
N  
O  
P

## BACK-UP LAMP

< REMOVAL AND INSTALLATION >

### BACK-UP LAMP

#### Exploded View

INFOID:000000009175414

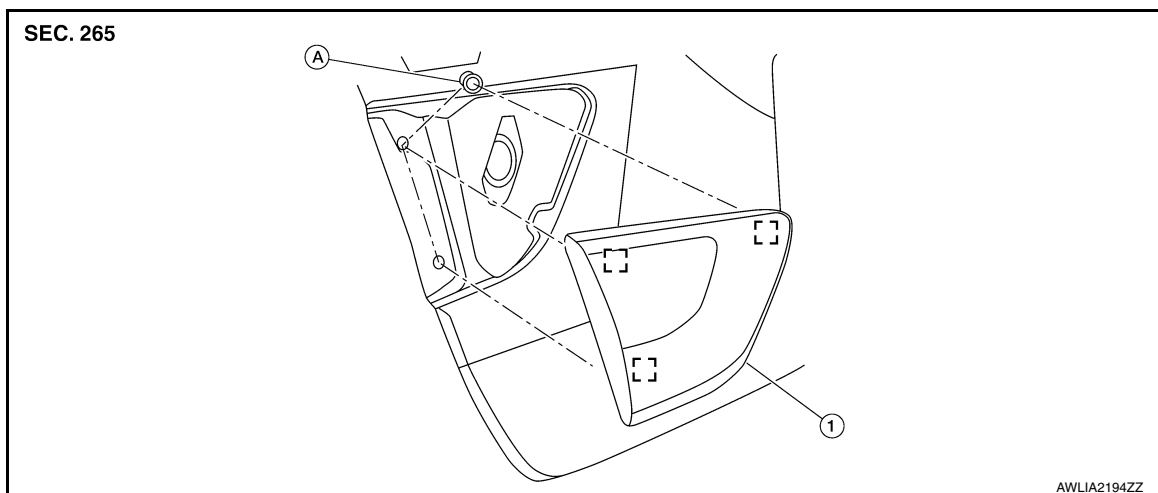

1. Back-up lamp

A. Nut

Stud

#### Removal and Installation

INFOID:000000009175415

#### BACK-UP LAMP

##### Removal

1. Remove back door lower finisher. Refer to [INT-35, "BACK DOOR LOWER FINISHER : Removal and Installation"](#).
2. Disconnect the harness connector from the back-up lamp.
3. Remove back-up lamp nuts and remove.

##### Installation

Installation is in the reverse order of removal.

#### BACK-UP LAMP BULB

##### **WARNING:**

**Do not touch bulb by hand while it is lit or right after being turned off. Burning may result.**

##### **CAUTION:**

- Do not touch glass surface of the bulb with bare hands or allow oil or grease to get on it to prevent damage to bulb.
- Do not leave the bulb out of the lamp reflector for a long time because dust, moisture, smoke, etc. may affect the performance of the lamp.

##### Removal

1. Remove back door trim access panel.
2. Rotate back-up lamp socket counterclockwise and remove.
3. Remove back-up lamp bulb from bulb socket.

##### Installation

Installation is in the reverse order of removal.



# LICENSE PLATE LAMP

< REMOVAL AND INSTALLATION >

## LICENSE PLATE LAMP

### Exploded View

INFOID:000000009175416

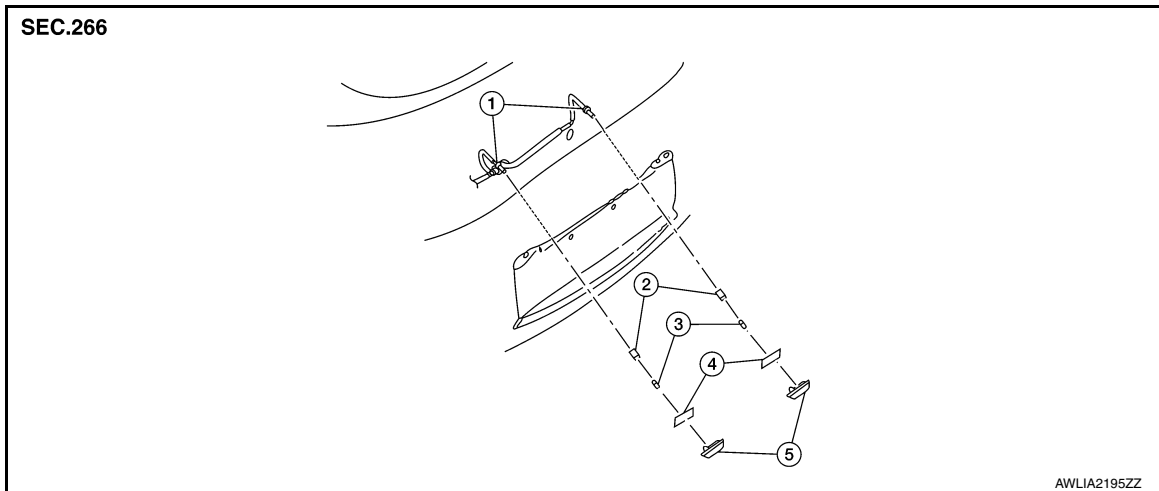

- |                               |                              |                            |
|-------------------------------|------------------------------|----------------------------|
| 1. License plate lamp harness | 2. License plate lamp socket | 3. License plate lamp bulb |
| 4. License plate lamp gasket  | 5. License plate lamp        |                            |

### Removal and Installation

INFOID:000000009175417

#### LICENSE PLATE LAMP

##### Removal

1. Remove back door outer finisher. Refer to [EXT-43. "Removal and Installation"](#).
2. Release pawls using a suitable tool and remove license plate lamp.

##### Installation

Installation is in the reverse order of removal.

#### LICENSE PLATE LAMP BULB

##### Removal

##### **WARNING:**

**Do not touch bulb by hand while it is lit or right after being turned off. Burning may result.**

##### **CAUTION:**

- Do not touch glass surface of the bulb with bare hands or allow oil or grease to get on it to prevent damage to bulb.
- Do not leave the bulb out of the lamp reflector for a long time because dust, moisture, smoke, etc. may affect the performance of the lamp.

1. Remove back door lower finisher. Refer to [INT-35. "BACK DOOR LOWER FINISHER : Removal and Installation"](#).
2. Disconnect the harness connector from the license plate lamp.

## LICENSE PLATE LAMP

### < REMOVAL AND INSTALLATION >

3. Rotate license plate lamp socket (1) counterclockwise and remove.
4. Remove license plate lamp bulb (2) from bulb socket.

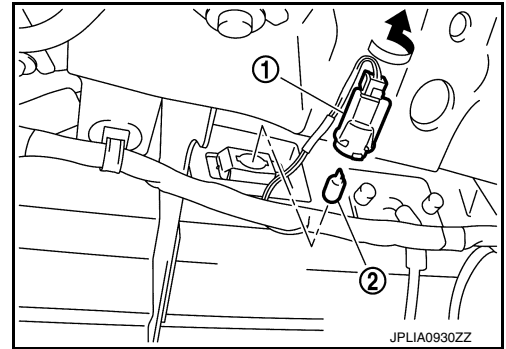

### Installation

Installation is in the reverse order of removal.

# FRONT COMBINATION LAMP

< UNIT DISASSEMBLY AND ASSEMBLY >

## UNIT DISASSEMBLY AND ASSEMBLY

### FRONT COMBINATION LAMP

Exploded View

INFOID:000000009175418

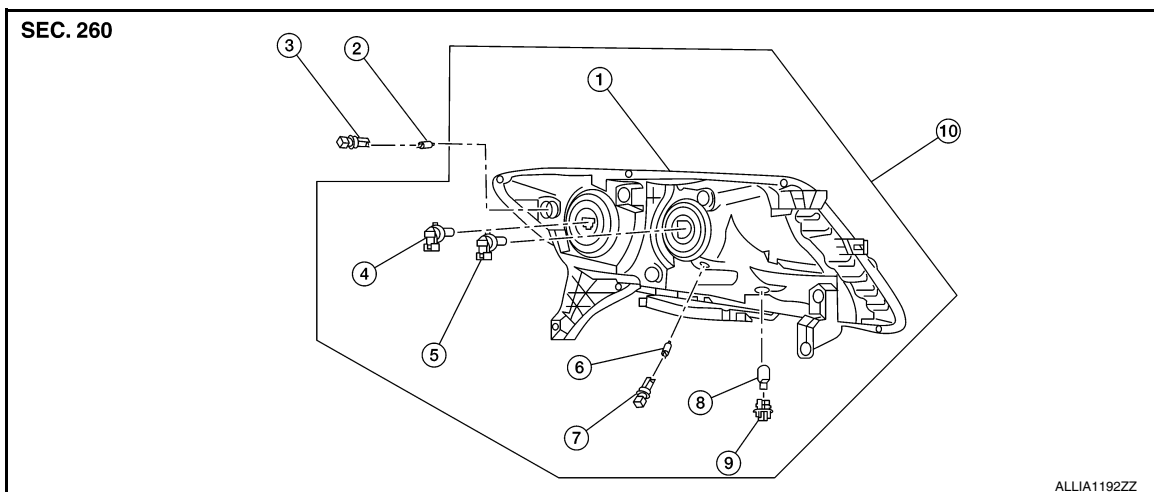

- |                                     |                                  |                                  |
|-------------------------------------|----------------------------------|----------------------------------|
| 1. Front combination lamp           | 2. Side marker lamp bulb         | 3. Side marker bulb socket       |
| 4. Halogen lamp bulb (low beam)     | 5. Halogen lamp bulb (high beam) | 6. Front turn signal lamp bulb   |
| 7. Parking lamp bulb socket         | 8. Parking lamp bulb             | 9. Front turn signal bulb socket |
| 10. Front combination lamp assembly |                                  |                                  |

### Disassembly and Assembly

INFOID:000000009175419

#### **WARNING:**

**Do not touch bulb by hand while it is lit or right after being turned off. Burning may result.**

#### **CAUTION:**

- Do not touch glass surface of the bulb with bare hands or allow oil or grease to get on it to prevent damage to bulb.
- Do not leave the bulb out of the lamp reflector for a long time because dust, moisture, smoke, etc. may affect the performance of the lamp.

#### DISASSEMBLY

1. Remove the front combination lamp. Refer to [EXL-141. "Removal and Installation"](#).
2. Rotate the halogen lamp bulb (low beam) counterclockwise and remove.
3. Rotate the halogen lamp bulb (high beam) counterclockwise and remove.
4. Rotate parking lamp socket counterclockwise and remove.
5. Remove parking lamp bulb from parking bulb socket.
6. Rotate front turn signal lamp socket counterclockwise and remove.
7. Remove front turn signal lamp bulb from front turn signal bulb socket.
8. Rotate side marker lamp socket counterclockwise and remove.
9. Remove side marker lamp bulb from side marker bulb socket.

#### ASSEMBLY

Assembly is in the reverse order of disassembly.

# REAR COMBINATION LAMP

< UNIT DISASSEMBLY AND ASSEMBLY >

## REAR COMBINATION LAMP

Exploded View

INFOID:000000009175420

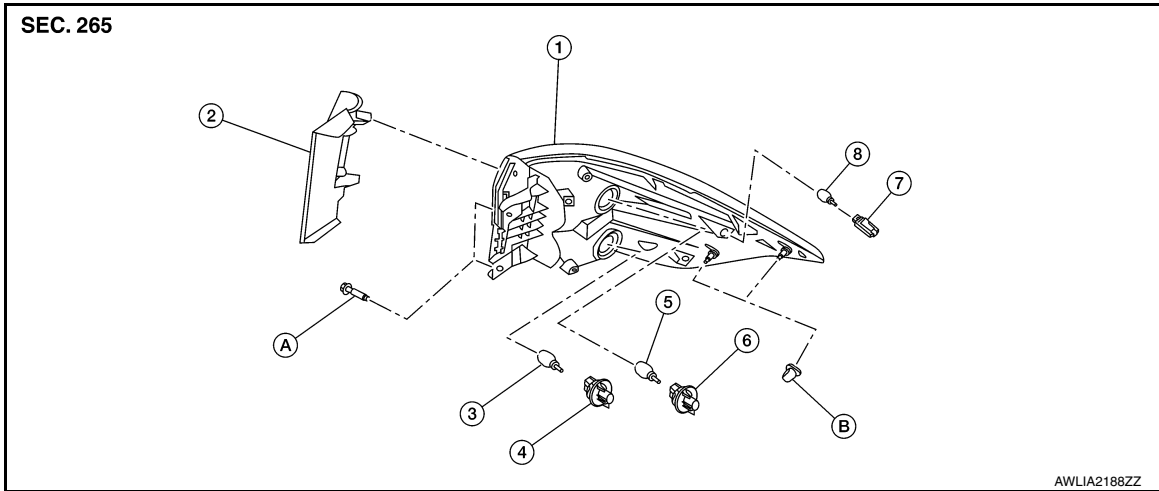

- |                                 |                                     |                               |
|---------------------------------|-------------------------------------|-------------------------------|
| 1. Rear combination lamp        | 2. Rear combination lamp bolt cover | 3. Rear turn signal lamp bulb |
| 4. Rear turn signal bulb socket | 5. Stop/Tail lamp bulb              | 6. Stop/Tail bulb socket      |
| 7. Side marker bulb socket      | 8. Side marker lamp bulb            | A. Bolt                       |
| B. Locator pin                  |                                     |                               |

### Disassembly and Assembly

INFOID:000000009175421

#### **WARNING:**

**Do not touch bulb by hand while it is lit or right after being turned off. Burning may result.**

#### **CAUTION:**

- **After installing, be sure to install the bulb sockets securely to ensure watertightness.**
- **Do not touch glass surface of the bulb with bare hands or allow oil or grease to get on it to prevent damage to bulb.**
- **Do not leave bulb out of lamp reflector for a long time because dust, moisture, smoke, etc. may affect the performance of lamp. When replacing bulb, be sure to replace it with new one.**

#### DISASSEMBLY

1. Remove rear combination lamp. Refer to [EXL-149. "Removal and Installation"](#)
2. Rotate rear turn signal lamp bulb socket counterclockwise and remove.
3. Remove rear turn signal bulb from bulb socket.
4. Rotate stop/tail lamp bulb socket counterclockwise and remove.
5. Remove stop/tail bulb from bulb socket.
6. Rotate side marker lamp bulb socket counterclockwise and remove.
7. Remove side marker bulb from bulb socket.

#### ASSEMBLY

Assembly is in the reverse order of disassembly.

# SERVICE DATA AND SPECIFICATIONS (SDS)

< SERVICE DATA AND SPECIFICATIONS (SDS)

## SERVICE DATA AND SPECIFICATIONS (SDS)

### SERVICE DATA AND SPECIFICATIONS (SDS)

#### Bulb Specifications

INFOID:000000009175422

	Item	Wattage (W) *
Front combination lamp	High beam	60
	Low beam	55
	Front turn signal lamp	21
	Parking lamp	5
	Side marker lamp	5
Front fog lamp	Fog lamp (if equipped)	55
Daytime running lamp built-in fog lamp (Canada only)		19
Rear combination lamp	Stop/Tail lamp	21/5
	Turn signal lamp	21
	Side marker lamp	5
Back-up lamp		12
License plate lamp		5
High-mounted stop lamp		—

\*: Always check with the Parts Department for the latest parts info.

A  
B  
C  
D  
E  
F  
G  
H  
I  
J  
K  
L  
M  
N  
O  
P

EXL