

SECTION **SE**
SEAT

A
B
C
D
E
F
G
H
I
SE
K
L
M
N
O
P

CONTENTS

PRECAUTION	3	WIRING DIAGRAM	16
PRECAUTIONS	3	POWER SEAT FOR DRIVER SIDE WITHOUT AUTOMATIC DRIVE POSITIONER	16
Precaution for Supplemental Restraint System (SRS) "AIR BAG" and "SEAT BELT PRE-TEN- SIONER"	3	Wiring Diagram	16
Occupant Classification System	3	POWER SEAT FOR PASSENGER SIDE	20
Precaution for Work	3	Wiring Diagram	20
PREPARATION	4	LUMBAR SUPPORT SYSTEM	24
PREPARATION	4	Wiring Diagram	24
Special Service Tool	4	HEATED SEAT SYSTEM	28
Commercial Service Tool	5	Wiring Diagram	28
CLIP LIST	6	CLIMATE CONTROLLED SEAT SYSTEM	37
Descriptions for Clips	6	Wiring Diagram	37
SYSTEM DESCRIPTION	10	BASIC INSPECTION	47
COMPONENT PARTS	10	DIAGNOSIS AND REPAIR WORK FLOW	47
CLIMATE CONTROLLED SEAT SYSTEM	10	Work Flow	47
CLIMATE CONTROLLED SEAT SYSTEM : Com- ponent Parts Location	10	DTC/CIRCUIT DIAGNOSIS	49
CLIMATE CONTROLLED SEAT SYSTEM : Com- ponent Description	10	POWER SUPPLY AND GROUND CIRCUIT	49
SYSTEM	12	CLIMATE CONTROLLED SEAT CONTROL UNIT	49
CLIMATE CONTROLLED SEAT SYSTEM	12	CLIMATE CONTROLLED SEAT CONTROL UNIT : Diagnosis Procedure	49
CLIMATE CONTROLLED SEAT SYSTEM : Sys- tem Diagram	12	CLIMATE CONTROLLED SEAT CONTROL UNIT : Component Inspection	52
CLIMATE CONTROLLED SEAT SYSTEM : Sys- tem Description	12	CLIMATE CONTROLLED SEAT SWITCH	53
ECU DIAGNOSIS INFORMATION	13	Component Function Check	53
CLIMATE CONTROLLED SEAT CONTROL UNIT	13	Diagnosis Procedure	53
Reference Value	13	Component Inspection	55
Fail-safe	14	SEATBACK THERMAL ELECTRIC DEVICE ...	56
		Component Function Check	56
		Diagnosis Procedure	56

SEATBACK THERMAL ELECTRIC DEVICE	Exploded View	77
SENSOR	Removal and Installation	86
Component Function Check	Seatback Board	87
Diagnosis Procedure	Seatback Thermal Electric Device	88
Component Inspection	Seat Cushion Thermal Electric Device	88
SEAT CUSHION THERMAL ELECTRIC DE-	Blower Motor Filter	89
VICE	Blower Motor	89
Component Function Check	SECOND ROW SEATS	91
Diagnosis Procedure	Exploded View	91
SEAT CUSHION THERMAL ELECTRIC DE-	Removal and Installation	94
VICE SENSOR	Armrest Assembly	96
Component Function Check	Seat Cushion	97
Diagnosis Procedure	Seat Cushion Release Cable	98
Component Inspection	Seat Slide Release Cable	100
CLIMATE CONTROLLED SEAT BLOWER	Recline Release Cable Assembly	102
MOTOR	EZ Entry Cable	104
Component Function Check	RH Seat Track Tilt Release Cable	105
Diagnosis Procedure	THIRD ROW SEATS	107
CLIMATE CONTROLLED SEAT SWITCH IN-	Exploded View	107
DI-CATOR	Removal and Installation	107
Component Function Check	UNIT DISASSEMBLY AND ASSEMBLY ..	109
Diagnosis Procedure	FRONT SEAT	109
CLIMATE CONTROLLED SEAT BLOWER	Exploded View	109
FILTER	Seatback	118
Diagnosis Procedure	Seat Cushion	120
SYMPTOM DIAGNOSIS	SECOND ROW SEAT	123
CLIMATE CONTROLLED SEAT SYSTEM	Exploded View	123
Symptom Table	LH SEAT	126
SQUEAK AND RATTLE TROUBLE DIAG-	LH SEAT : Seatback	126
NOSES	LH SEAT : Seat Cushion	128
Work Flow	RH SEAT	128
Generic Squeak and Rattle Troubleshooting	RH SEAT : Seatback	129
Diagnostic Worksheet	RH SEAT : Seat Cushion	130
REMOVAL AND INSTALLATION	THIRD ROW SEAT	132
FRONT SEAT	Exploded View	132
	Seatback	132
	Seat Cushion	134

PRECAUTIONS

< PRECAUTION >

PRECAUTION

PRECAUTIONS

Precaution for Supplemental Restraint System (SRS) "AIR BAG" and "SEAT BELT PRE-TENSIONER"

INFOID:000000009754961

The Supplemental Restraint System such as "AIR BAG" and "SEAT BELT PRE-TENSIONER", used along with a front seat belt, helps to reduce the risk or severity of injury to the driver and front passenger for certain types of collision. Information necessary to service the system safely is included in the SR and SB section of this Service Manual.

WARNING:

- To avoid rendering the SRS inoperative, which could increase the risk of personal injury or death in the event of a collision which would result in air bag inflation, all maintenance must be performed by an authorized NISSAN/INFINITI dealer.
- Improper maintenance, including incorrect removal and installation of the SRS, can lead to personal injury caused by unintentional activation of the system. For removal of Spiral Cable and Air Bag Module, see the SR section.
- Do not use electrical test equipment on any circuit related to the SRS unless instructed to in this Service Manual. SRS wiring harnesses can be identified by yellow and/or orange harnesses or harness connectors.

PRECAUTIONS WHEN USING POWER TOOLS (AIR OR ELECTRIC) AND HAMMERS

WARNING:

- When working near the Airbag Diagnosis Sensor Unit or other Airbag System sensors with the Ignition ON or engine running, DO NOT use air or electric power tools or strike near the sensor(s) with a hammer. Heavy vibration could activate the sensor(s) and deploy the air bag(s), possibly causing serious injury.
- When using air or electric power tools or hammers, always switch the Ignition OFF, disconnect the battery and wait at least three minutes before performing any service.

Occupant Classification System

INFOID:000000009760392

Replace occupant classification system as part of the passenger front seat frame assembly. Refer to [SE-109](#), "[Exploded View](#)".

Precaution for Work

INFOID:000000009754962

- When removing or disassembling each component, be careful not to damage or deform it. If a component may be subject to interference, be sure to protect it with a shop cloth.
- When removing (disengaging) components with a screwdriver or similar tool, be sure to wrap the component with a shop cloth or vinyl tape to protect it.
- Protect the removed parts with a shop cloth and prevent them from being dropped.
- Replace a deformed or damaged clip.
- If a part is specified as a non-reusable part, always replace it with a new one.
- Be sure to tighten bolts and nuts securely to the specified torque.
- After installation is complete, be sure to check that each part works properly.
- Follow the steps below to clean components:
 - Water soluble dirt:
 - Dip a soft cloth into lukewarm water, wring the water out of the cloth and wipe the dirty area.
 - Then rub with a soft, dry cloth.
 - Oily dirt:
 - Dip a soft cloth into lukewarm water with mild detergent (concentration: within 2 to 3%) and wipe the dirty area.
 - Then dip a cloth into fresh water, wring the water out of the cloth and wipe the detergent off.
 - Then rub with a soft, dry cloth.
 - Do not use organic solvent such as thinner, benzene, alcohol or gasoline.
 - For genuine leather seats, use a genuine leather seat cleaner.

PREPARATION

< PREPARATION >



PREPARATION

PREPARATION

Special Service Tool

INFOID:000000009754970

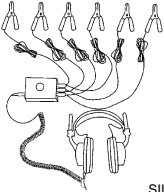
The actual shapes of Kent-Moore tools may differ from those of special service tools illustrated here.

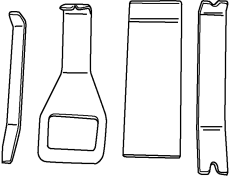
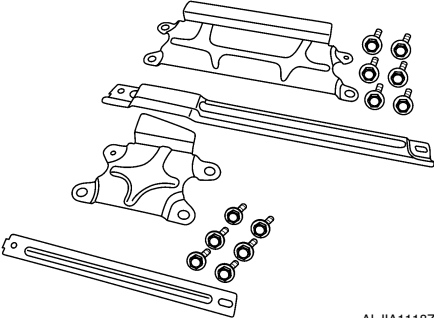
Tool number (Kent-Moore No.) Tool name	Description
<p>— (J-39570) Chassis Ear</p>  <p style="text-align: center;">SIIA0993E</p>	Locating the noise
<p>— (J-50397) NISSAN Squeak and Rattle Kit</p>  <p style="text-align: center;">ALJIA1232ZZ</p>	Repairing the cause of noise
<p>— (J-46534) Trim Tool Set</p>  <p style="text-align: center;">AWJIA0483ZZ</p>	Removing trim components
<p>— (J-51030) Seat Fixture Kit</p>  <p style="text-align: center;">ALJIA1118ZZ</p>	Securing second row seat slides for removal and installation of seat assembly

PREPARATION

< PREPARATION >

Commercial Service Tool

INFOID:000000009754971

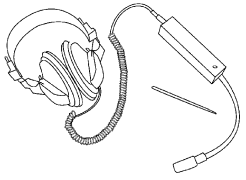
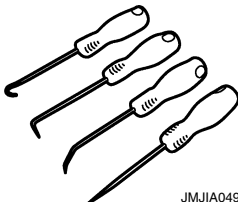
(Kent-Moore No.) Tool name	Description
(J-39565) Engine Ear  <p style="text-align: right; margin-right: 50px;">SIIA0995E</p>	Locating the noise
(—) Hook and Pick Tool  <p style="text-align: right; margin-right: 50px;">JM/JIA0490ZZ</p>	Removes snap rings

A
B
C
D
E
F
G
H
I

SE

K
L
M
N
O
P

CLIP LIST







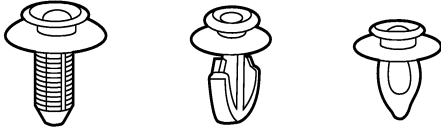

< PREPARATION >

CLIP LIST

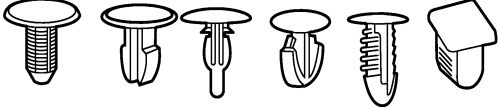
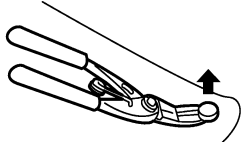
Descriptions for Clips

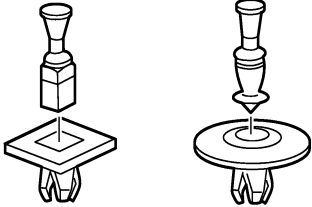
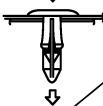
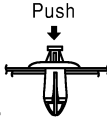
INFOID:000000009176458

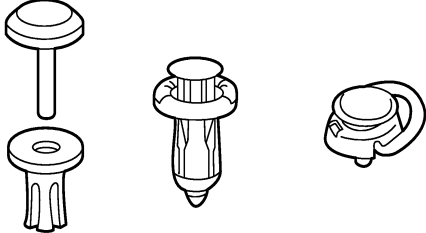
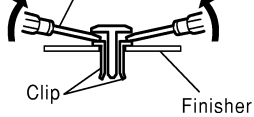

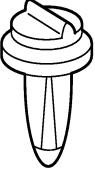
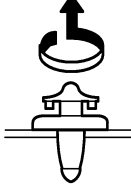





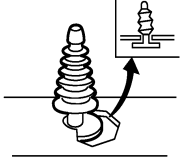
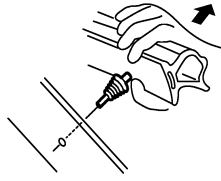

Replace any clips which are damaged during removal or installation.

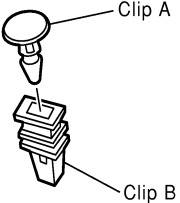
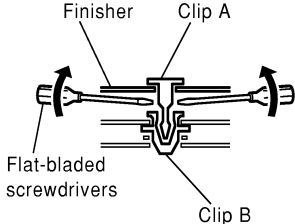
Symbol No.	Shapes	Removal & Installation
<p>C101</p> 		<p>Removal: Remove by bending up with flat-bladed screwdrivers or clip remover.</p> 
<p>C103</p> 		 <p>Removal: Remove with a clip remover.</p>
<p>C203</p> 		<p>Removal: Push center pin to catching position. (Do not remove center pin by hitting it.)</p> <p>Push</p>  <p>Installation:</p> 
<p>C205</p> 		<p>Removal:</p> 
<p>C206</p> 		<p>Removal:</p> 

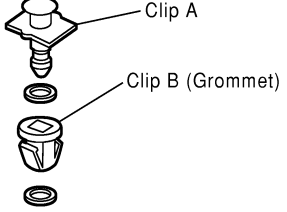
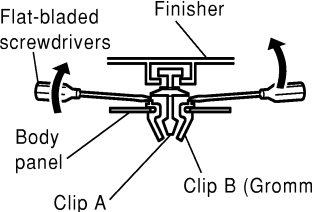
SIIA0315E

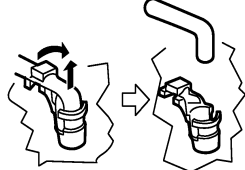
CLIP LIST

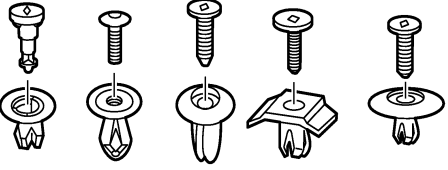
< PREPARATION >









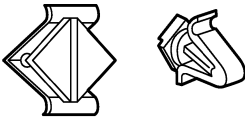

Symbol No.	Shapes	Removal & Installation
CE103 		Removal: 
CF110 		Removal: 
CF118 		Removal: 
CR103 		Removal: Holder portion of clip must be spread out to remove rod. 
CS101 		Removal: 1. Screw out with a Phillips screwdriver. 2. Remove female portion with flat-bladed screwdriver. 

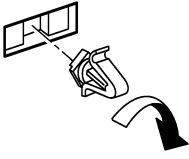
SIIA0316E

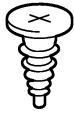
A
B
C
D
E
F
G
H
I
SE
K
L
M
N
O
P

CLIP LIST

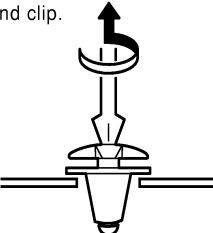

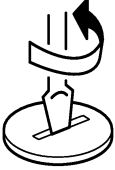
< PREPARATION >

Symbol No.	Shapes	Removal & Installation	
CG101 		Removal:  Rotate 45° to remove	Installation: 
CS102 			
CS113 		Removal: Disconnect upper connection of clip with a flat-bladed screwdriver, then remove clip while inserting a flat-bladed screwdriver between body panel and clip. 	
C111 			

SIIA0317E

CLIP LIST

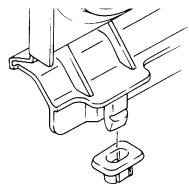
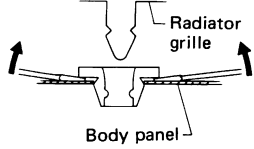
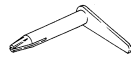
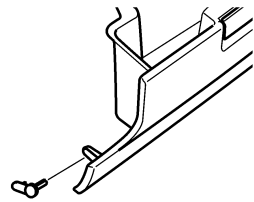
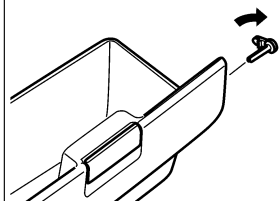
< PREPARATION >

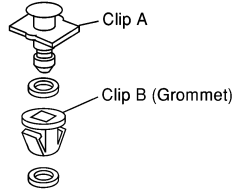
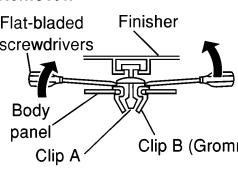
Symbol No.	Shapes	Removal & Installation
<p>CG104</p> 		<p>Removal: Remove by bending up with flat-bladed screwdrivers.</p>  <p>Radiator grille Body panel</p>
<p>CE114</p> 		
<p>CF118</p> 	 <p>Clip A Clip B (Grommet)</p>	<p>Removal: Flat-bladed screwdrivers Finisher</p>  <p>Body panel Clip A Clip B (Grommet)</p>

ALJIA0564GB

A
B
C
D
E
F
G
H
I

SE

K
L
M
N
O
P

COMPONENT PARTS

< SYSTEM DESCRIPTION >

SYSTEM DESCRIPTION

COMPONENT PARTS

CLIMATE CONTROLLED SEAT SYSTEM

CLIMATE CONTROLLED SEAT SYSTEM : Component Parts Location

INFOID:000000009176459

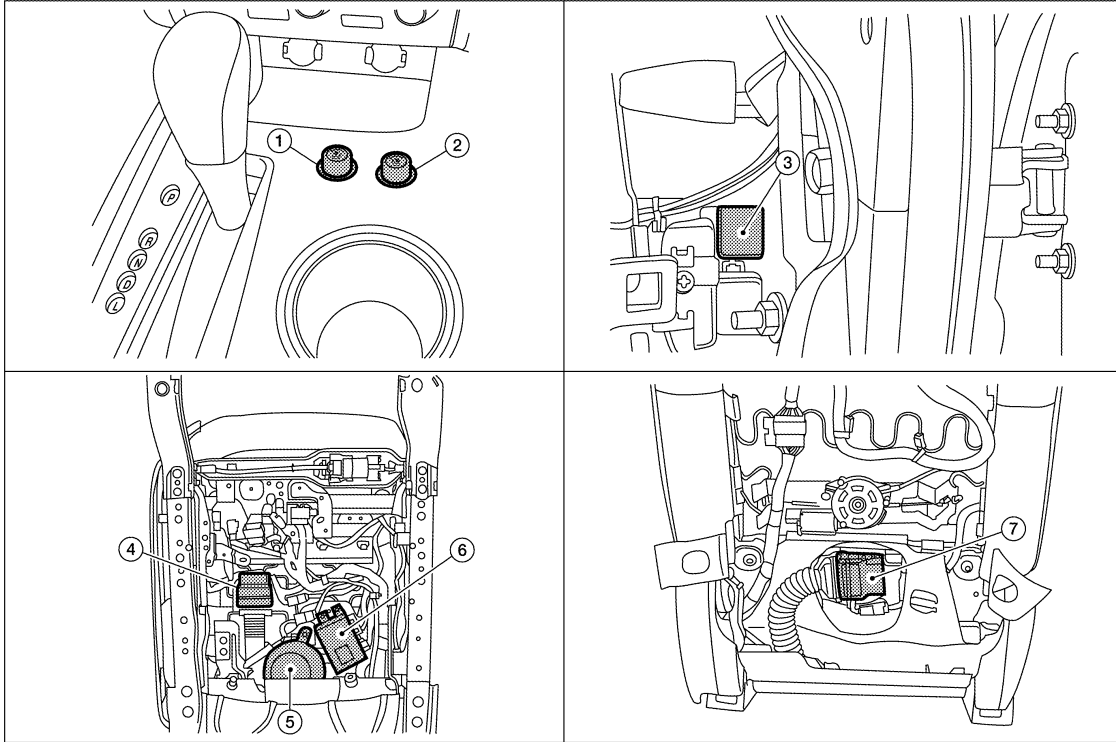

ALJIA1033ZZ

- | | | |
|---|--|--|
| 1. Climate controlled seat switch (driver seat) | 2. Climate controlled seat switch (passenger seat) | 3. Climate controlled seat relay (view with instrument panel RH removed) |
| 4. Seat cushion thermal electric device | 5. Climate controlled seat blower motor | 6. Climate controlled seat control unit |
| 7. Seat back thermal electric device | | |

CLIMATE CONTROLLED SEAT SYSTEM : Component Description

INFOID:000000009176460

Item	Function
Climate controlled seat relay	Supplies power to the climate controlled seat control unit in accordance with the key switch position that is ON or OFF
Climate controlled seat control unit	Installed in the seat cushion and controls the climate controlled seat blower motor, seat-back thermal electric device, and seat cushion thermal electric device in accordance with the input signal
Climate controlled seat switch	Installed in the center console and transmits signals to climate controlled seat control unit in accordance with the HEAT (heated airflow) or COOL (cooled airflow) switch operation and the temperature switch operation
Climate controlled seat blower motor	Installed in the seat cushion and sends the airflow to the seatback thermal electric device and seat cushion thermal electric device in accordance with the control from the climate controlled seat control unit

COMPONENT PARTS

< SYSTEM DESCRIPTION >

Item	Function
Seatback thermal electric device	Installed in the seatback and heats or cools the airflow from the climate controlled seat blower motor in accordance with the control from the climate controlled seat control unit
Seat cushion thermal electric device	Installed in the seat cushion and heats or cools the airflow from the climate controlled seat blower motor in accordance with the control from the climate controlled seat control unit

A

B

C

D

E

F

G

H

I

SE

K

L

M

N

O

P

SYSTEM

< SYSTEM DESCRIPTION >

SYSTEM

CLIMATE CONTROLLED SEAT SYSTEM

CLIMATE CONTROLLED SEAT SYSTEM : System Diagram

INFOID:000000009176461

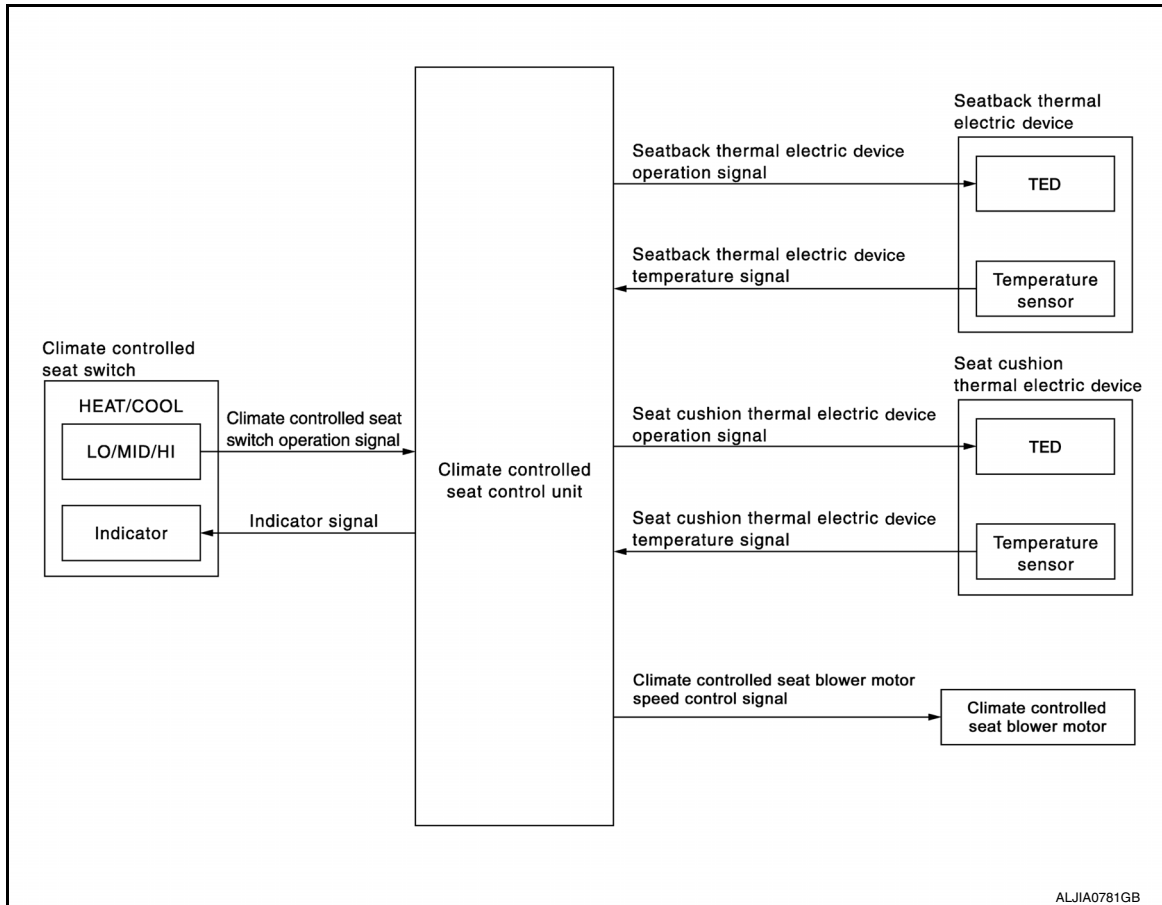

ALJIA0781GB

CLIMATE CONTROLLED SEAT SYSTEM : System Description

INFOID:000000009176462

- The climate controlled seat system is controlled by the climate controlled seat control unit.
- Operation of the climate controlled seat switch sends heated or cooled airflow and adjusts the seat temperature.

SEAT CUSHION AND SEATBACK TEMPERATURE ADJUSTMENT FUNCTION

- A thermal electric device (TED) is installed in the seat cushion and seatback. The device heats or cools, sends airflow to the seat surface, and adjusts the seat temperature.
- The thermal electric device (TED) is a heat exchanger that has a function to heat or cool the airflow from the climate controlled seat blower motor. By changing the direction of the current from the power supply, the device takes or gives heat, and adjusts the heat exchange process depending on voltage.

NOTE:

The climate controlled seat blower motor maintains low speed for approximately 60 seconds after turning the climate controlled seat switch off.

CAUTION:

- **The thermal electric device has a dual-climate function that allows one side to operate at a high temperature and the other to operate at a low temperature simultaneously.**
- **Before starting work, always turn OFF the switch and check that the thermal electric device is cold.**

FAIL-SAFE

The fail-safe function is adopted for the climate controlled seat control unit. Refer to [SE-14. "Fail-safe"](#).

CLIMATE CONTROLLED SEAT CONTROL UNIT

< ECU DIAGNOSIS INFORMATION >

ECU DIAGNOSIS INFORMATION

CLIMATE CONTROLLED SEAT CONTROL UNIT

Reference Value

INFOID:000000009176463

TERMINAL LAYOUT

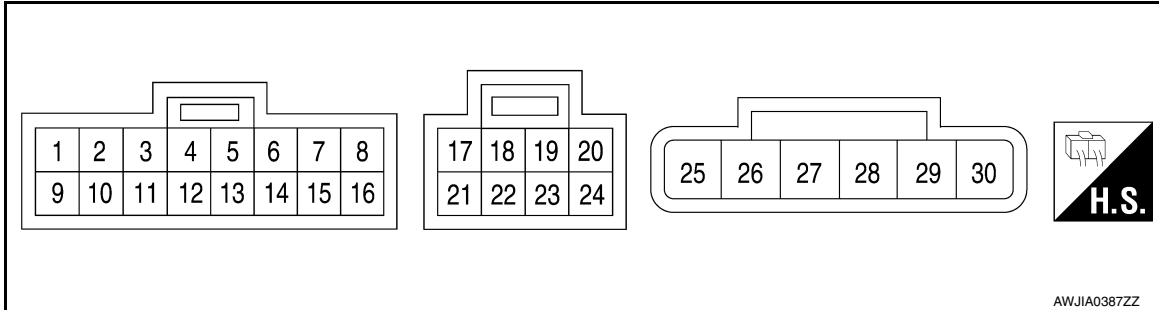

PHYSICAL VALUES

Terminal	Wire color	Item	Signal Input/ Output	Condition		Voltage (Approx.)	
1	LG	HEAT switch signal	Input	Ignition switch ON or START	Climate controlled seat switch select	HI HEAT	2.6V – 3.5V
						MED HEAT	1.6V – 2.5V
						LO HEAT	0.5V – 1.5V
						OFF	0V
4	P	Blower motor speed control signal	Input	Ignition switch ON or START	Climate controlled seat switch select	HEAT or COOL	4.5V – 8.0V
						OFF	0V
6	G	Blower motor ground	—	—		0V	
7	R	Blower motor power supply	Input	Ignition switch ON or START		Battery voltage	
9	W	COOL switch signal	Input	Ignition switch ON or START	Climate controlled seat switch select	HI COOL	2.6V – 3.5V
						MED COOL	1.6V – 2.5V
						LO COOL	0.5V – 1.5V
						OFF	0V
13	Y	Seat cushion thermal electric device sensor ground	—	Ignition switch ON		0V	
14	BR	Seat cushion thermal electric device sensor signal	Input	Blower motor operated		0.5V – 4.0V	
				Ignition switch OFF		0V	
15	V	Seatback thermal electric device sensor ground	—	Ignition switch ON		0V	
16	L	Seatback thermal electric device sensor signal	Input	Blower motor operated		0.5V – 4.0V	
				Ignition switch OFF		0V	
19	Y	HEAT switch indicator signal	Input	Ignition switch ON or START	Climate controlled seat switch select	HEAT	Battery voltage
						OFF	0V
20	V	COOL switch indicator signal	Input	Ignition switch ON or START	Climate controlled seat switch select	COOL	Battery voltage
						OFF	0V
21	R	Ignition switch power supply	Output	Ignition switch ON		Battery voltage	
24	G	Climate controlled seat switch power supply	Input	Ignition switch ON		Battery voltage	

CLIMATE CONTROLLED SEAT CONTROL UNIT

< ECU DIAGNOSIS INFORMATION >

Terminal	Wire color	Item	Signal Input/ Output	Condition		Voltage (Approx.)	
25	G	Seatback thermal electric device power supply (COOL)	Output	Ignition switch ON or START	Climate controlled seat switch select	COOL	Battery voltage
						HEAT	0V
						OFF	0V
26	LG	Seat cushion thermal electric device power supply (COOL)	Output	Ignition switch ON or START	Climate controlled seat switch select	COOL	Battery voltage
						HEAT	0V
						OFF	0V
27	L	Seat cushion thermal electric device power supply (HEAT)	Output	Ignition switch ON or START	Climate controlled seat switch select	HEAT	Battery voltage
						COOL	0V
						OFF	0V
28	W	Seatback thermal electric device power supply (HEAT)	Output	Ignition switch ON or START	Climate controlled seat switch select	HEAT	Battery voltage
						COOL	0V
						OFF	0V
29	R	Battery power supply	Input	Ignition switch ON		Battery voltage	
30	B	Ground	—	—		0V	

Fail-safe

INFOID:000000009176464

- Climate controlled seat control unit equips fail-safe function.
- When a malfunction occurs in the systems shown as per the following, climate controlled seat control unit stops output.

Malfunction	Malfunctioning condition
The temperature difference between the seatback thermal electric device and seat cushion thermal electric device is 30°C (86°F) or more	<ul style="list-style-type: none"> • When it detects for 4 seconds that the temperature difference between the seatback thermal electric device and seat cushion thermal electric device is 30°C (86°F) or more, stops the output to the thermal electric device, activates the climate controlled seat blower motor in the maximum position, and sends the external airflow for 30 seconds. • If the temperature difference is still 30°C (86°F) or more after 30 seconds pass, it stops all output and enters the system OFF condition. • When the temperature difference between seatback thermal electric device and seat cushion thermal electric device becomes 20°C (68°F) or less, the system recovers automatically. • If it detects that the temperature difference is 30°C (86°F) or more after the automatic system recovery, it immediately stops all output and enters the system OFF condition. <p>NOTE: When the switch operation is performed before entering the system OFF condition, the fail-safe mode is reset.</p>
The temperature of thermal electric device is 110°C (230°F) or more in the HEAT mode (any thermal electric device in the seatback or seat cushion)	<ul style="list-style-type: none"> • When it detects for 4 seconds that the temperature of the thermal electric device is 110°C (230°F) or more, stops the output to the thermal electric device, activates the climate controlled seat blower motor in the maximum position, and sends the external airflow for 30 seconds. • If the temperature does not become 105°C (221°F) or less after 30 seconds pass, it stops all output and enters the system OFF condition. • When the temperature of the thermal electric device becomes 105°C (221°F) or less, the system recovers automatically. • If it detects that the temperature of the thermal electric device is 110°C (230°F) or more after the automatic system recovery, it immediately stops all output and enters the system OFF condition.

CLIMATE CONTROLLED SEAT CONTROL UNIT

< ECU DIAGNOSIS INFORMATION >

Malfunction	Malfunctioning condition	
The temperature of the thermal electric device is 45°C (113°F) or more in the COOL mode (any thermal electric device in the seatback or seat cushion)	<ul style="list-style-type: none"> When it detects for 4 seconds that the temperature of the thermal electric device is between 45°C (113°F) and 70°C (158°F), it starts the temperature monitoring of the thermal electric device at 3 second intervals. While monitoring, if it detects that the temperature raises 2°C (36°F) or more 4 times continuously or reaches 70°C (158°F) or more, it stops all output and enters the system OFF condition. If it detects other results of monitoring, it continues activating in the COOL mode. 	A B C
Thermal electric device sensor system open circuit	<ul style="list-style-type: none"> When it detects for 4 seconds that the thermal electric device sensor system is an open circuit. 	D
Climate controlled seat blower motor system open circuit	<ul style="list-style-type: none"> When it detects for 2 seconds that climate controlled seat blower motor system is an open circuit while the climate controlled seat is being activated, it stops output to the thermal electric device. When it detects for 10 seconds that the climate controlled seat blower motor system is an open circuit while the climate controlled seat is being activated, it stops all output and enters the system OFF condition. <p>NOTE: After detecting the climate seat blower motor system open circuit for 2 seconds, the system recovers automatically if the activation of the climate controlled seat blower motor is detected for 1 second or more.</p>	E F
Switch input out of the specified range	<ul style="list-style-type: none"> When it detects for 4 seconds that the rotary switch input is 30% or less of the vehicle battery voltage, it stops all output and enters the system OFF condition. When the switch input returns to a value within the specified range, the system recovers automatically. 	G H
HEAT or COOL switch input out of the specified range	<ul style="list-style-type: none"> When it detects for 4 seconds that rotary switch input is 6% or less of the vehicle battery voltage, it stops all output and enters the system OFF condition. When the switch input returns to a value within the specified range, the system recovers automatically. 	I
System voltage out of range	<ul style="list-style-type: none"> System voltage* of the climate controlled seat control unit is out of the operation range (8.5 V – 16.5 V). 	SE

*: System voltage is the voltage between climate controlled seat control unit power source and the ground.

NOTE:

When the system enters in the fail-safe mode again after performing resetting procedure, perform diagnosis.

A
B
C
D
E
F
G
H
I
SE
K
L
M
N
O
P

POWER SEAT FOR DRIVER SIDE WITHOUT AUTOMATIC DRIVE POSITIONER

< WIRING DIAGRAM >

WIRING DIAGRAM

POWER SEAT FOR DRIVER SIDE WITHOUT AUTOMATIC DRIVE POSITIONER

Wiring Diagram

INFOID:000000009176465

POWER SEAT FOR DRIVER SIDE - WITHOUT AUTOMATIC DRIVE POSITIONER

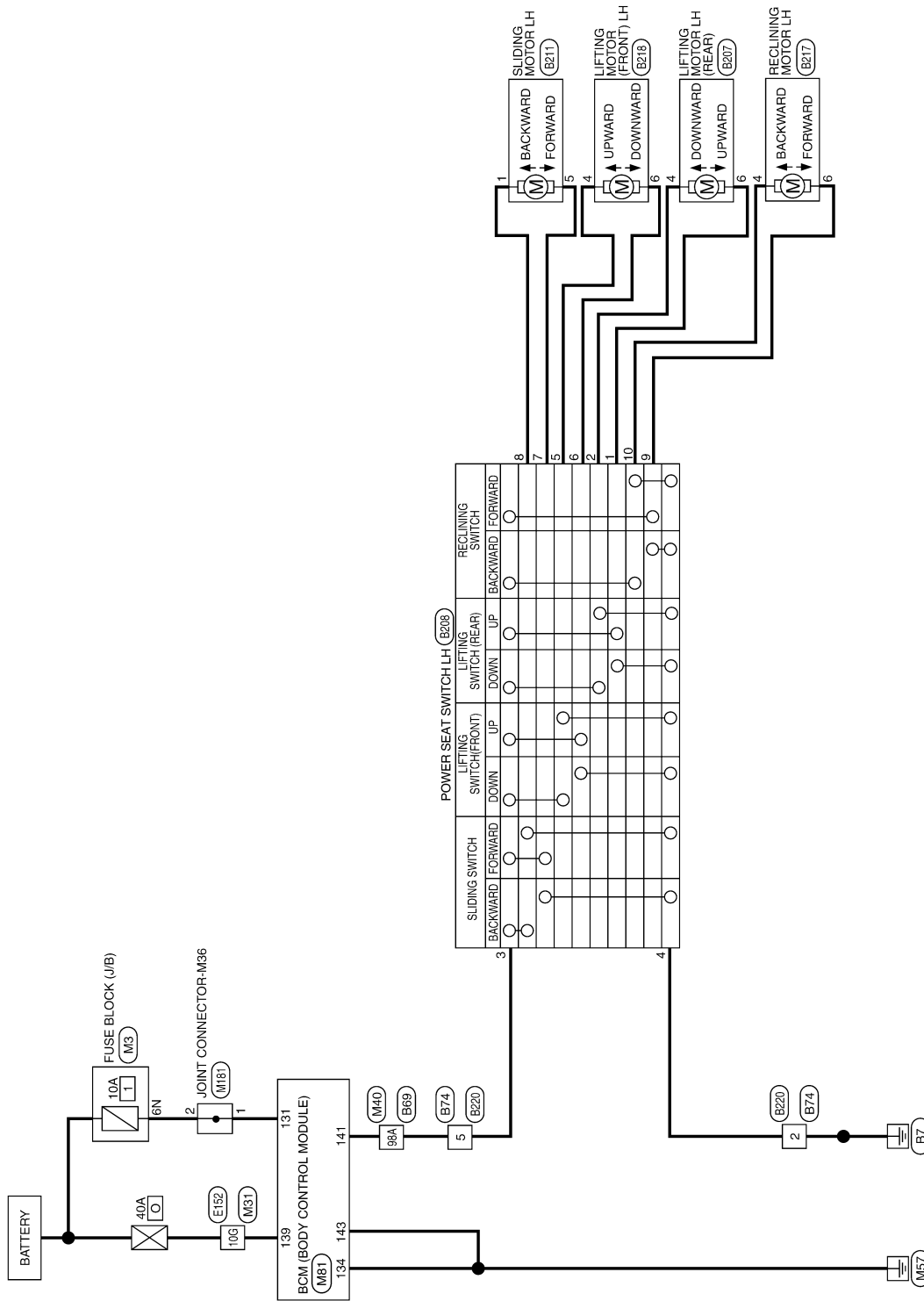

ABJWA0352GB

POWER SEAT FOR DRIVER SIDE WITHOUT AUTOMATIC DRIVE POSITIONER

< WIRING DIAGRAM >

POWER SEAT FOR DRIVE SIDE CONNECTORS - WITHOUT AUTOMATIC DRIVE POSITIONER

Connector No.	M3
Connector Name	FUSE BLOCK (J/B)
Connector Color	WHITE

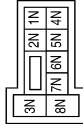

Terminal No.	Color of Wire	Signal Name
6N	W	-

Connector No.	M31
Connector Name	WIRE TO WIRE
Connector Color	WHITE

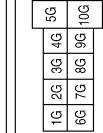

Terminal No.	Color of Wire	Signal Name								
11G	2G	13G	4G	15G	16G	17G	18G	19G	20G	21G
22G	23G	24G	25G	26G	27G	28G	29G	30G		
31G	32G	33G	34G	35G	36G	37G	38G	39G	40G	41G
42G	43G	44G	45G	46G	47G	48G	49G	50G		
51G	52G	53G	54G	55G	56G	57G	58G	59G	60G	61G
62G	63G	64G	65G	66G	67G	68G	69G	70G		
71G	72G	73G	74G	75G	76G	77G	78G	79G	80G	81G
82G	83G	84G	85G	86G	87G	88G	89G	90G		
91G	92G	93G	94G	95G						
96G	97G	98G	99G	100G						

Terminal No.	Color of Wire	Signal Name
10G	W	-

Connector No.	M40
Connector Name	WIRE TO WIRE
Connector Color	GRAY

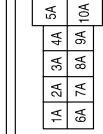

Terminal No.	Color of Wire	Signal Name								
11A	12A	13A	14A	15A	16A	17A	18A	19A	20A	21A
22A	23A	24A	25A	26A	27A	28A	29A	30A		
31A	32A	33A	34A	35A	36A	37A	38A	39A	40A	41A
42A	43A	44A	45A	46A	47A	48A	49A	50A		
51A	52A	53A	54A	55A	56A	57A	58A	59A	60A	61A
62A	63A	64A	65A	66A	67A	68A	69A	70A		
71A	72A	73A	74A	75A	76A	77A	78A	79A	80A	81A
82A	83A	84A	85A	86A	87A	88A	89A	90A		
91A	92A	93A	94A	95A						
96A	97A	98A	99A	100A						

Terminal No.	Color of Wire	Signal Name
98A	Y	-(WITHOUT AUTOMATIC DRIVE POSITIONER)

Connector No.	M81
Connector Name	BCM (BODY CONTROL MODULE)
Connector Color	WHITE

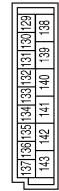

Terminal No.	Color of Wire	Signal Name
131	W	BAT BCM FUSE
134	B	GND 2
139	W	BAT POWER F/L
141	Y	PW POWER SUPPLY BAT
143	B	GND 1

Connector No.	M181
Connector Name	JOINT CONNECTOR-M36
Connector Color	WHITE

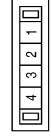

Terminal No.	Color of Wire	Signal Name
1	W	-
2	W	-

ABJIA0830GB

A B C D E F G H I SE K L M N O P

POWER SEAT FOR DRIVER SIDE WITHOUT AUTOMATIC DRIVE POSITIONER

< WIRING DIAGRAM >

Connector No.	B74
Connector Name	WIRE TO WIRE
Connector Color	WHITE

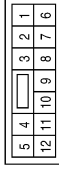

Terminal No.	Color of Wire	Signal Name
2	GR	-(WITHOUT CLIMATE CONTROLLED SEAT)
5	L	-

Connector No.	B69
Connector Name	WIRE TO WIRE
Connector Color	GRAY

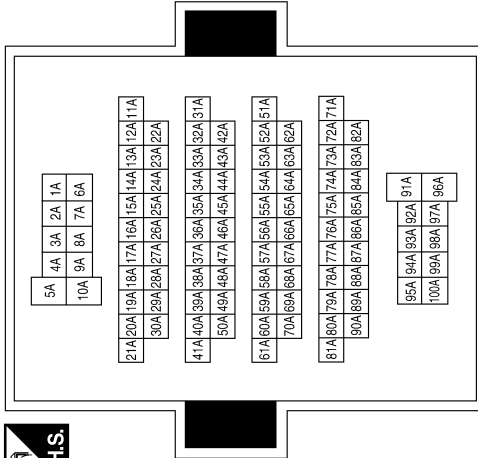
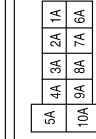

Terminal No.	Color of Wire	Signal Name
98A	L	-

Connector No.	E152
Connector Name	WIRE TO WIRE
Connector Color	WHITE

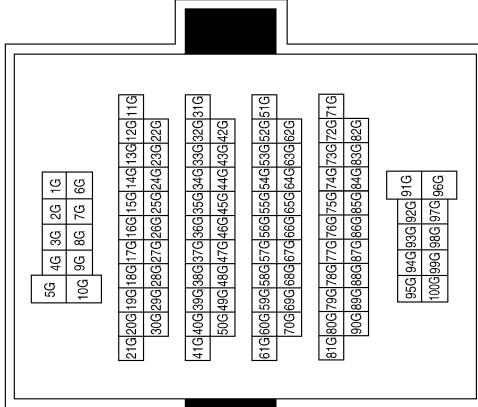
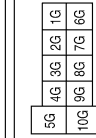

Terminal No.	Color of Wire	Signal Name
10G	P	-

Terminal No.	Color of Wire	Signal Name
4	R	-(WITHOUT AUTOMATIC DRIVE POSITIONER)
6	V	-(WITHOUT AUTOMATIC DRIVE POSITIONER)

Connector No.	B207
Connector Name	LIFTING MOTOR LH (REAR)
Connector Color	WHITE



ABJIA0831GB

POWER SEAT FOR DRIVER SIDE WITHOUT AUTOMATIC DRIVE POSITIONER

< WIRING DIAGRAM >

Connector No.	B211
Connector Name	SLIDING MOTOR LH
Connector Color	GRAY

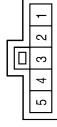

Terminal No.	Color of Wire	Signal Name
1	SB	-(WITHOUT AUTOMATIC DRIVE POSITIONER)
5	L	-(WITHOUT AUTOMATIC DRIVE POSITIONER)

Terminal No.	Color of Wire	Signal Name
3	R	-(WITHOUT AUTOMATIC DRIVE POSITIONER)
4	B	-
5	G	-
6	Y	-
7	L	-
8	SB	-
9	P	-
10	BR	-

Connector No.	B208
Connector Name	POWER SEAT SWITCH LH
Connector Color	WHITE

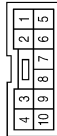

Terminal No.	Color of Wire	Signal Name
1	V	-
2	R	-

Connector No.	B220
Connector Name	WIRE TO WIRE
Connector Color	WHITE

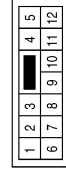

Terminal No.	Color of Wire	Signal Name
2	B	-
5	R	-

Connector No.	B218
Connector Name	LIFTING MOTOR LH (FRONT)
Connector Color	WHITE



Terminal No.	Color of Wire	Signal Name
4	G	-(WITHOUT AUTOMATIC DRIVE POSITIONER)
6	Y	-(WITHOUT AUTOMATIC DRIVE POSITIONER)

Connector No.	B217
Connector Name	RECLINING MOTOR LH
Connector Color	WHITE



Terminal No.	Color of Wire	Signal Name
4	BR	-(WITHOUT AUTOMATIC DRIVE POSITIONER)
6	P	-(WITHOUT AUTOMATIC DRIVE POSITIONER)

ABJIA0832GB

A
B
C
D
E
F
G
H
I
SE
K
L
M
N
O
P

POWER SEAT FOR PASSENGER SIDE

< WIRING DIAGRAM >

POWER SEAT FOR PASSENGER SIDE

Wiring Diagram

INFOID:000000009176466

RD: WITH REAR ENTERTAINMENT SYSTEM
 RE: WITHOUT REAR ENTERTAINMENT SYSTEM

POWER SEAT FOR PASSENGER SIDE

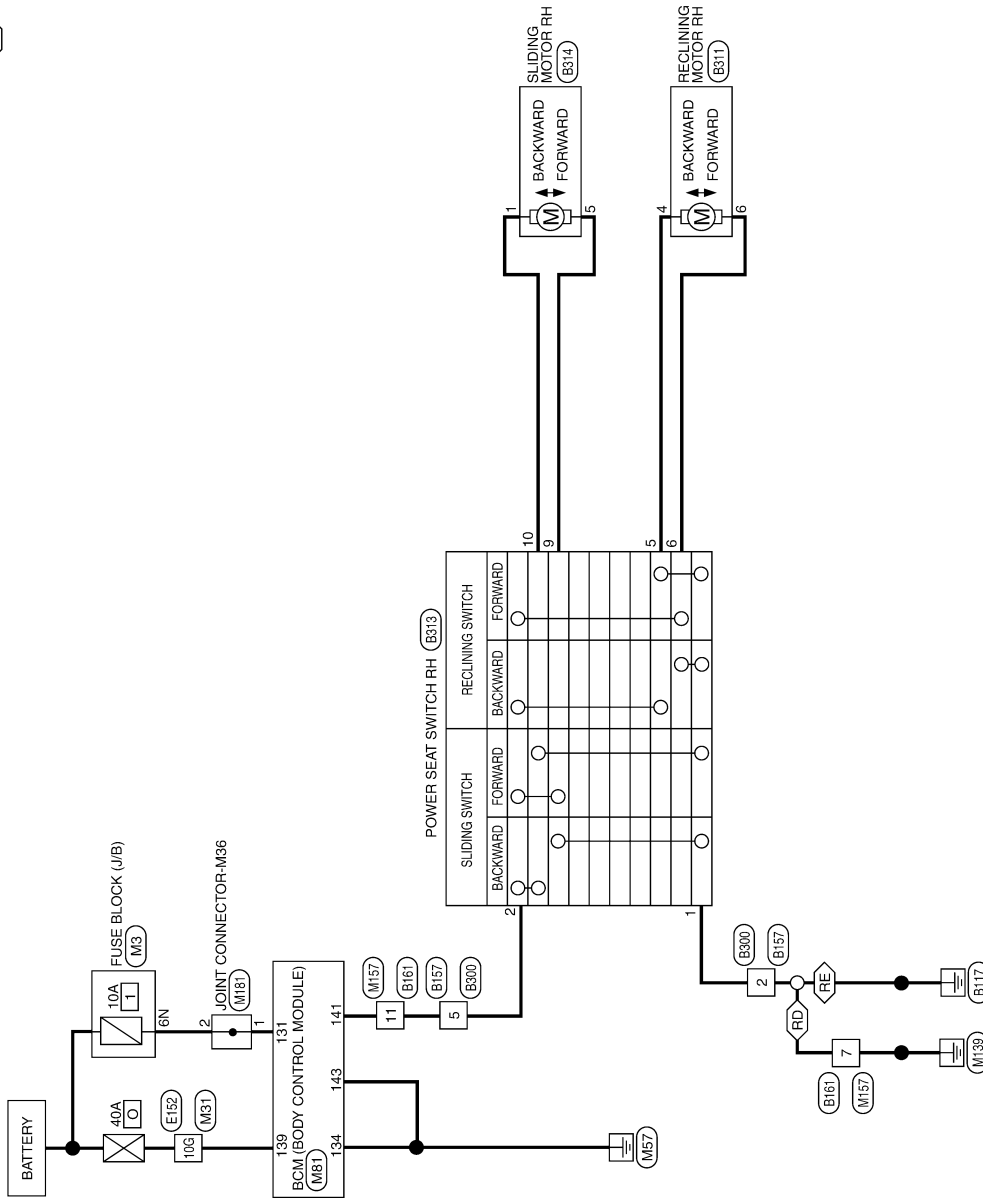

ABJWA0353GB

POWER SEAT FOR PASSENGER SIDE

< WIRING DIAGRAM >

POWER SEAT FOR PASSENGER SIDE CONNECTORS

Connector No.	M3
Connector Name	FUSE BLOCK (J/B)
Connector Color	WHITE

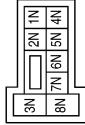

Terminal No.	Color of Wire	Signal Name
6N	W	-

Connector No.	M31
Connector Name	WIRE TO WIRE
Connector Color	WHITE

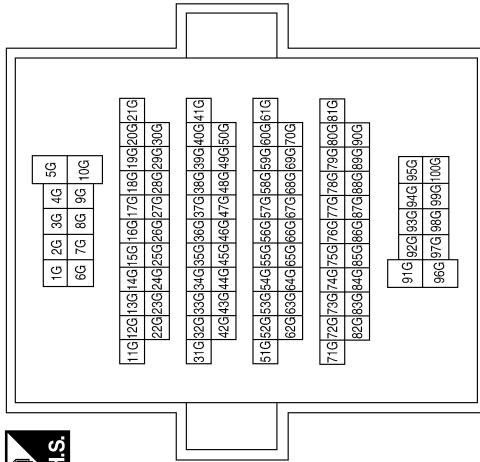

Terminal No.	Color of Wire	Signal Name
10G	W	-

Connector No.	M81
Connector Name	BCM (BODY CONTROL MODULE)
Connector Color	WHITE

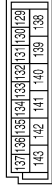

Terminal No.	Color of Wire	Signal Name
131	W	BAT BCM FUSE
134	B	GND 2
139	W	BAT POWER F/L
141	Y	P/W POWER SUPPLY BAT
143	B	GND 1

Connector No.	M157
Connector Name	WIRE TO WIRE
Connector Color	WHITE

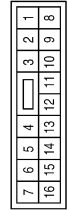

Terminal No.	Color of Wire	Signal Name
7	GR	-
11	Y	-

Connector No.	M181
Connector Name	JOINT CONNECTOR-M36
Connector Color	WHITE

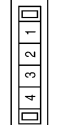

Terminal No.	Color of Wire	Signal Name
1	W	-
2	W	-

A B C D E F G H I J K L M N O P

SE

POWER SEAT FOR PASSENGER SIDE

< WIRING DIAGRAM >

Connector No.	B157
Connector Name	WIRE TO WIRE
Connector Color	WHITE

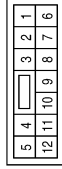

Terminal No.	Color of Wire	Signal Name
2	B	-
5	LG	-

Terminal No.	Color of Wire	Signal Name
10G	P	-

Connector No.	E152
Connector Name	WIRE TO WIRE
Connector Color	WHITE

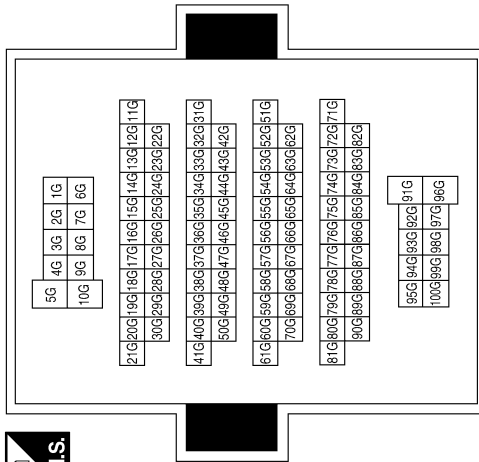

Connector No.	B311
Connector Name	RECLINING MOTOR RH
Connector Color	WHITE



Terminal No.	Color of Wire	Signal Name
1	-	-
2	-	-
3	-	-
4	BR	-
5	-	-
6	P	-

Connector No.	B300
Connector Name	WIRE TO WIRE
Connector Color	WHITE

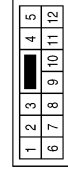

Terminal No.	Color of Wire	Signal Name
2	B	-
5	P	-

Connector No.	B161
Connector Name	WIRE TO WIRE
Connector Color	WHITE

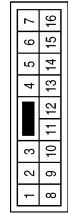

Terminal No.	Color of Wire	Signal Name
7	B	-
11	LG	-

ABJIA0833GB

POWER SEAT FOR PASSENGER SIDE

< WIRING DIAGRAM >

Connector No.	B314
Connector Name	SLIDING MOTOR RH
Connector Color	WHITE

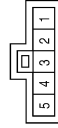

Terminal No.	Color of Wire	Signal Name
1	SB	-
2	-	-
3	-	-
4	-	-
5	L	-

Terminal No.	Color of Wire	Signal Name
5	BR	-
6	P	-
7	-	-
8	-	-
9	L	-
10	SB	-

Connector No.	B313
Connector Name	POWER SEAT SWITCH RH
Connector Color	WHITE



Terminal No.	Color of Wire	Signal Name
1	B	-
2	R	-
3	-	-
4	-	-

A
B
C
D
E
F
G
H
I
SE
K
L
M
N
O
P

ABJIA0834GB

LUMBAR SUPPORT SYSTEM

< WIRING DIAGRAM >

LUMBAR SUPPORT SYSTEM

Wiring Diagram

INFOID:000000009176467

LUMBAR SUPPORT SYSTEM

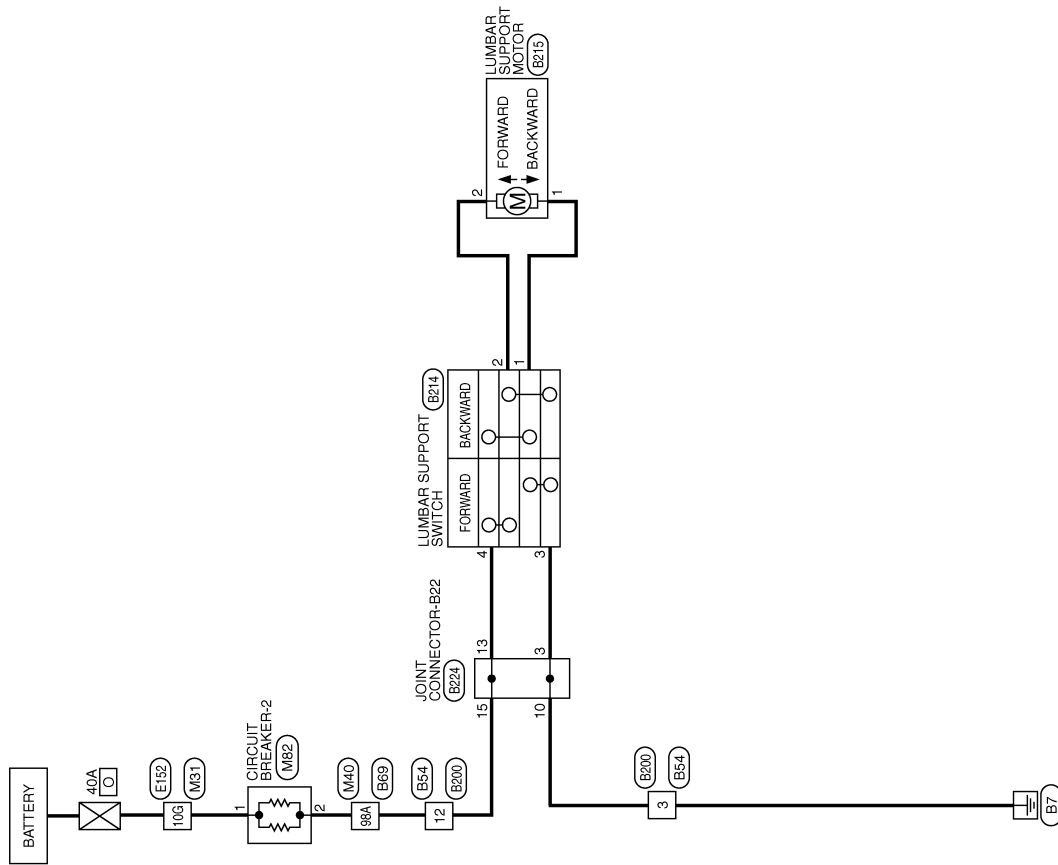

ABJWA0354GB

LUMBAR SUPPORT SYSTEM

< WIRING DIAGRAM >

LUMBAR SUPPORT SYSTEM CONNECTORS

Connector No.	M31
Connector Name	WIRE TO WIRE
Connector Color	WHITE

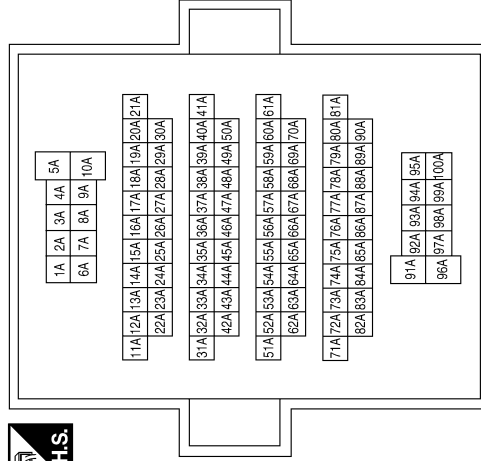

Terminal No.	Color of Wire	Signal Name
10G	W	-

Connector No.	M40
Connector Name	WIRE TO WIRE
Connector Color	GRAY

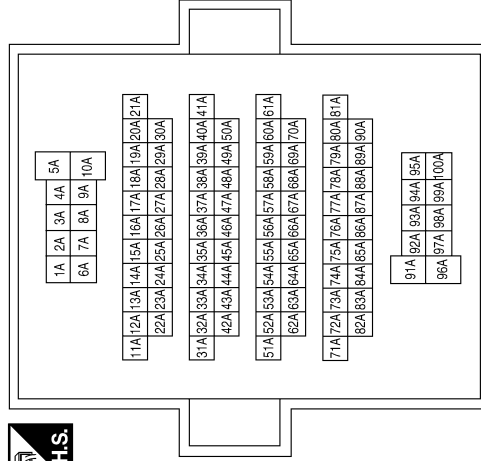

Terminal No.	Color of Wire	Signal Name
98A	L	- (WITH AUTOMATIC DRIVE POSITIONER)

Connector No.	M82
Connector Name	CIRCUIT BREAKER-2
Connector Color	WHITE

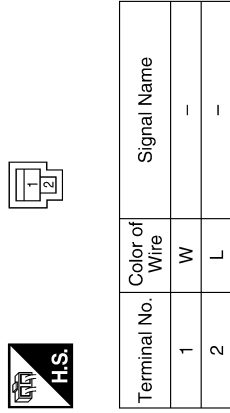

Terminal No.	Color of Wire	Signal Name
1	W	-
2	L	-

A
B
C
D
E
F
G
H
I
SE
K
L
M
N
O
P

LUMBAR SUPPORT SYSTEM

< WIRING DIAGRAM >

Connector No.	E152
Connector Name	WIRE TO WIRE
Connector Color	WHITE

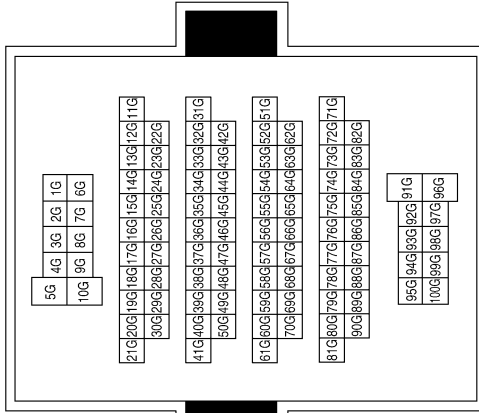

Terminal No.	Color of Wire	Signal Name
10G	P	-

Connector No.	B54
Connector Name	WIRE TO WIRE
Connector Color	BROWN

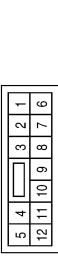

Terminal No.	Color of Wire	Signal Name
3	B	-
12	L	-

Connector No.	B69
Connector Name	WIRE TO WIRE
Connector Color	GRAY

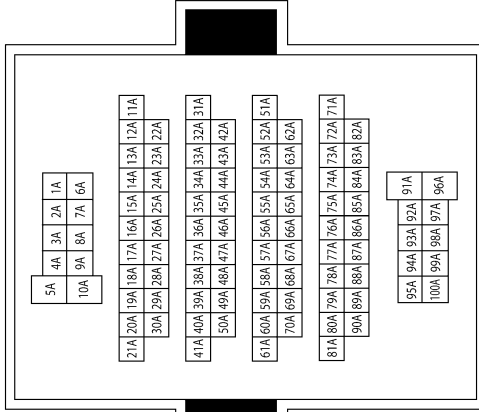

Terminal No.	Color of Wire	Signal Name
98A	L	-

Connector No.	B200
Connector Name	WIRE TO WIRE
Connector Color	BROWN



Terminal No.	Color of Wire	Signal Name
3	B	-
12	R	-

Connector No.	B214
Connector Name	LUMBAR SUPPORT SWITCH
Connector Color	BROWN



Terminal No.	Color of Wire	Signal Name
1	G	-
2	Y	-
3	B	-
4	R	-

Connector No.	B215
Connector Name	LUMBAR SUPPORT MOTOR
Connector Color	BLACK



Terminal No.	Color of Wire	Signal Name
1	G	-
2	Y	-

LUMBAR SUPPORT SYSTEM

< WIRING DIAGRAM >

A
B
C
D
E
F
G
H
I
SE
K
L
M
N
O
P

Connector No.	B224
Connector Name	JOINT CONNECTOR-B22
Connector Color	PINK

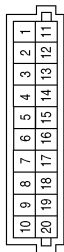

Terminal No.	Color of Wire	Signal Name
3	B	-
10	B	-
13	R	-
15	R	-

ABJIA0840GB

HEATED SEAT SYSTEM

< WIRING DIAGRAM >

HEATED SEAT SYSTEM

Wiring Diagram

INFOID:000000009176468

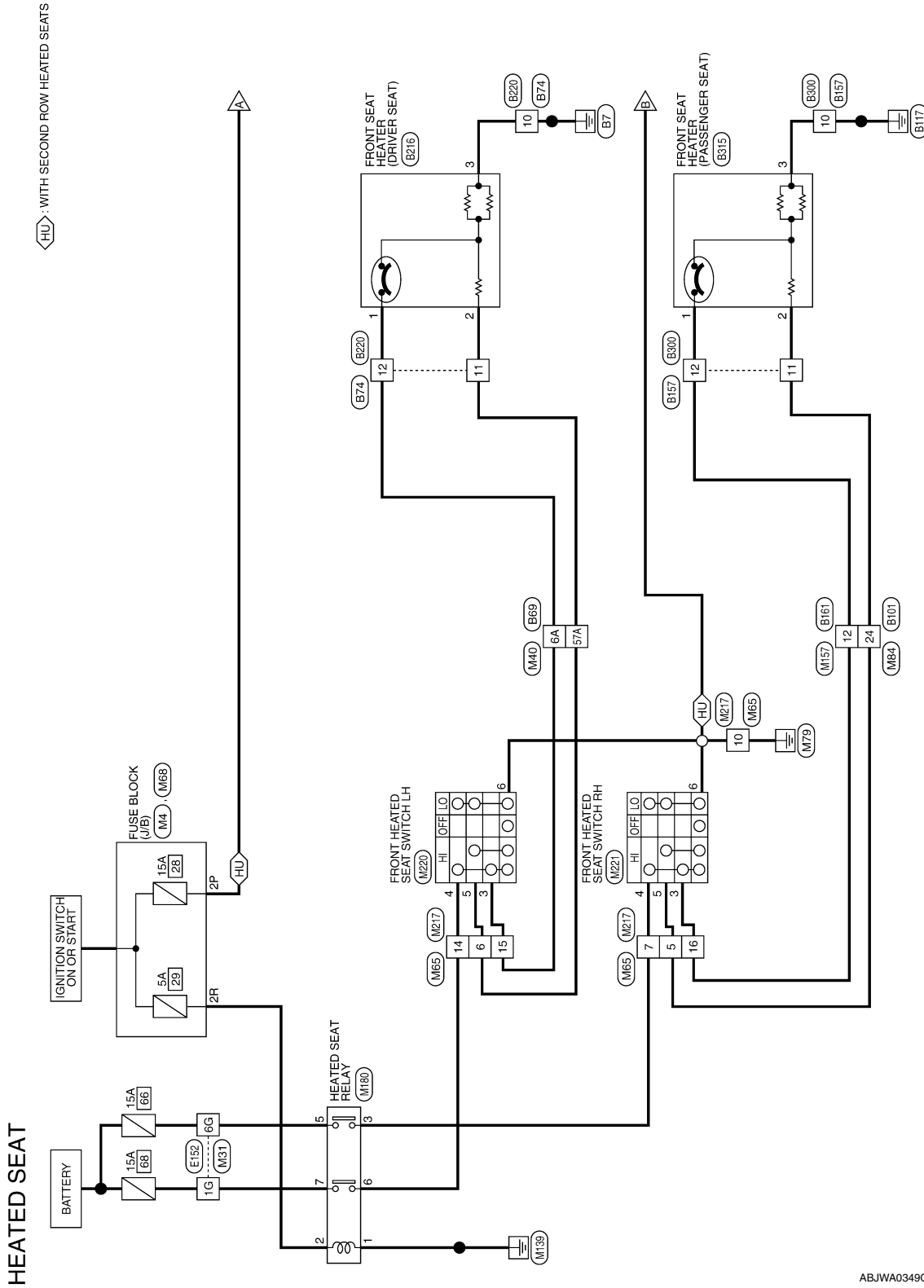

ABJWA0349GB

HEATED SEAT SYSTEM

< WIRING DIAGRAM >

⬠HU⬠: WITH SECOND ROW HEATED SEATS

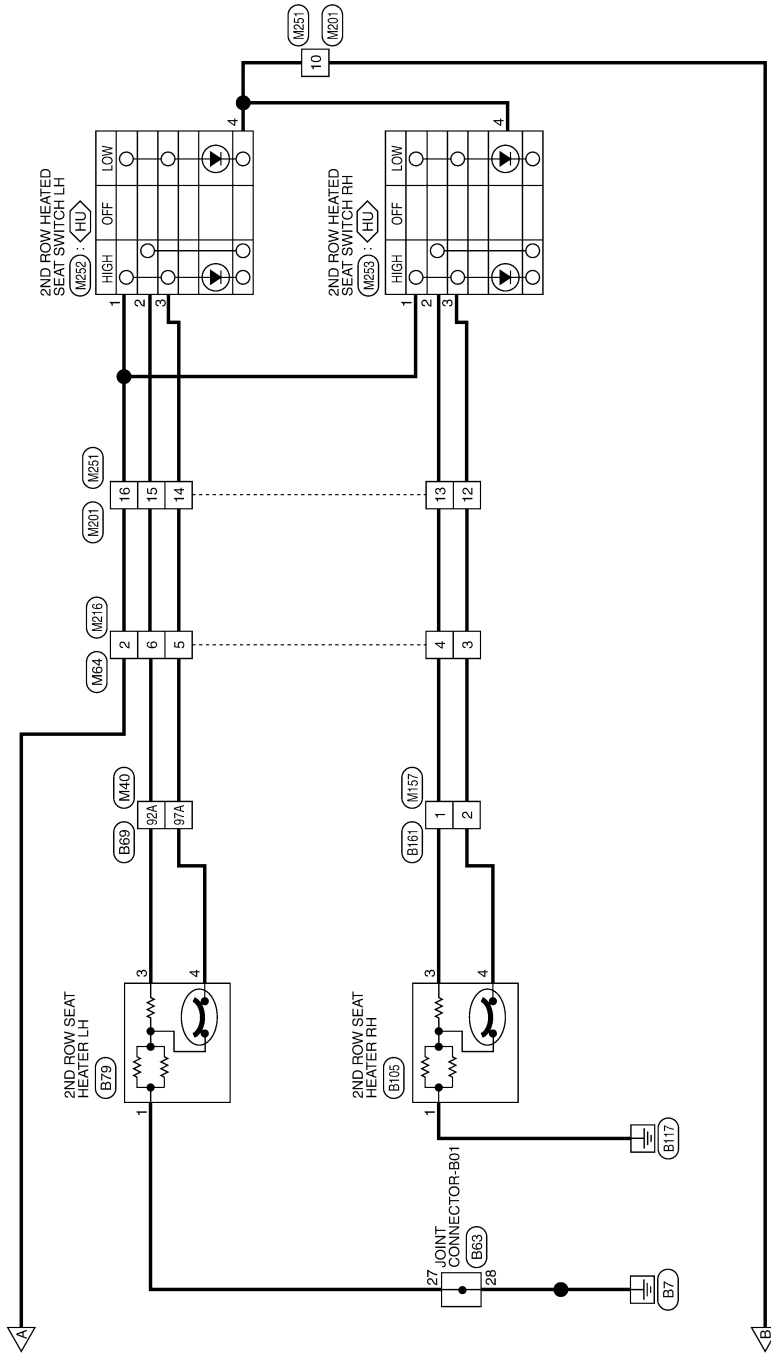

ABJWA0350GB

A
B
C
D
E
F
G
H
I
SE
K
L
M
N
O
P

HEATED SEAT SYSTEM

< WIRING DIAGRAM >

HEATED SEAT CONNECTORS

Connector No.	M4
Connector Name	FUSE BLOCK (J/B)
Connector Color	WHITE



Terminal No.	Color of Wire	Signal Name
2P	LG	-

Connector No.	M31
Connector Name	WIRE TO WIRE
Connector Color	WHITE

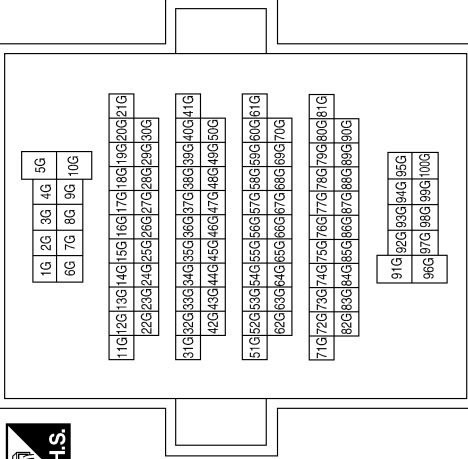

Terminal No.	Color of Wire	Signal Name
1G	SB	-(WITHOUT CLIMATE CONTROLLED SEAT)
1G	P	-(WITH CLIMATE CONTROLLED SEAT)
6G	SB	-(WITHOUT CLIMATE CONTROLLED SEAT)
6G	R	-(WITH CLIMATE CONTROLLED SEAT)

Connector No.	M64
Connector Name	WIRE TO WIRE
Connector Color	WHITE



ABJIA0823GB

Connector No.	M40
Connector Name	WIRE TO WIRE
Connector Color	GRAY

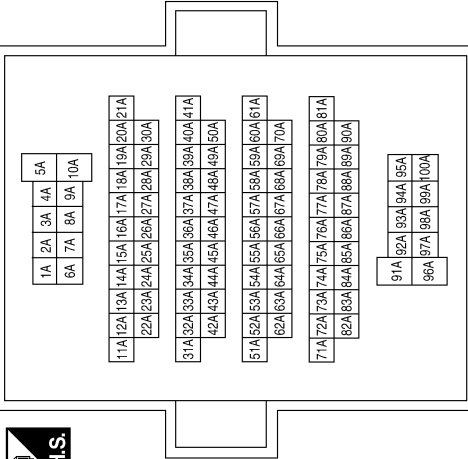

Terminal No.	Color of Wire	Signal Name
6A	LG	-(WITHOUT CLIMATE CONTROLLED SEAT)
6A	G	-(WITH CLIMATE CONTROLLED SEAT)
57A	SB	-(WITHOUT CLIMATE CONTROLLED SEAT)
57A	P	-(WITH CLIMATE CONTROLLED SEAT)
92A	L	-
97A	SB	-

Terminal No.	Color of Wire	Signal Name
5	SB	-
6	LG	-

HEATED SEAT SYSTEM

< WIRING DIAGRAM >

Connector No.	M68
Connector Name	FUSE BLOCK (J/B)
Connector Color	BROWN



Terminal No.	Color of Wire	Signal Name
2R	LG	-

Terminal No.	Color of Wire	Signal Name
14	L	-(WITHOUT CLIMATE CONTROLLED SEAT)
14	G	-(WITH CLIMATE CONTROLLED SEAT)
15	LG	-(WITHOUT CLIMATE CONTROLLED SEAT)
15	P	-(WITH CLIMATE CONTROLLED SEAT)
16	LG	-(WITHOUT CLIMATE CONTROLLED SEAT)
16	W	-(WITH CLIMATE CONTROLLED SEAT)

Connector No.	M65
Connector Name	WIRE TO WIRE
Connector Color	WHITE

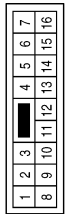

Terminal No.	Color of Wire	Signal Name
5	V	-
6	SB	-(WITHOUT CLIMATE CONTROLLED SEAT)
6	BR	-(WITH CLIMATE CONTROLLED SEAT)
7	BG	-
10	B	-

Connector No.	M180
Connector Name	HEATED SEAT RELAY
Connector Color	BROWN



Terminal No.	Color of Wire	Signal Name
1	GR	-
2	LG	-
3	BG	-
5	SB	-
6	L	-
7	SB	-

Connector No.	M157
Connector Name	WIRE TO WIRE
Connector Color	WHITE

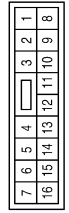

Terminal No.	Color of Wire	Signal Name
1	Y	-
2	BR	-
12	LG	-(WITHOUT CLIMATE CONTROLLED SEAT)
12	W	-(WITH CLIMATE CONTROLLED SEAT)

Connector No.	M84
Connector Name	WIRE TO WIRE
Connector Color	WHITE

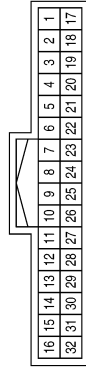

Terminal No.	Color of Wire	Signal Name
24	V	-(WITHOUT CLIMATE CONTROLLED SEAT)
24	R	-(WITH CLIMATE CONTROLLED SEAT)

ABJIA0824GB

A
B
C
D
E
F
G
H
I
SE
K
L
M
N
O
P

HEATED SEAT SYSTEM

< WIRING DIAGRAM >

Connector No.	M216
Connector Name	WIRE TO WIRE
Connector Color	WHITE

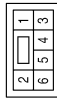

Terminal No.	Color of Wire	Signal Name
2	Y	-
3	BR	-
4	LG	-
5	L	-
6	LG	-

Connector No.	M201
Connector Name	WIRE TO WIRE
Connector Color	WHITE



Terminal No.	Color of Wire	Signal Name
10	B	-
12	BR	-
13	LG	-
14	L	-
15	LG	-
16	Y	-

Connector No.	M220
Connector Name	FRONT HEATED SEAT SWITCH LH
Connector Color	WHITE



Terminal No.	Color of Wire	Signal Name
3	LG	-
4	L	-
5	SB	-
6	GR	-

Terminal No.	Color of Wire	Signal Name
10	B	-
14	L	-(WITHOUT CLIMATE CONTROLLED SEAT)
14	BG	-(WITH CLIMATE CONTROLLED SEAT)
15	LG	-(WITHOUT CLIMATE CONTROLLED SEAT)
15	P	-(WITH CLIMATE CONTROLLED SEAT)
16	LG	-(WITHOUT CLIMATE CONTROLLED SEAT)
16	V	-(WITH CLIMATE CONTROLLED SEAT)

Connector No.	M217
Connector Name	WIRE TO WIRE
Connector Color	WHITE



Terminal No.	Color of Wire	Signal Name
5	V	-
6	SB	-(WITHOUT CLIMATE CONTROLLED SEAT)
6	Y	-(WITH CLIMATE CONTROLLED SEAT)
7	BG	-(WITHOUT CLIMATE CONTROLLED SEAT)
7	BR	-(WITH CLIMATE CONTROLLED SEAT)

ABJIA0836GB

HEATED SEAT SYSTEM

< WIRING DIAGRAM >

Connector No.	M252
Connector Name	2ND ROW HEATED SEAT SWITCH LH
Connector Color	WHITE



Terminal No.	Color of Wire	Signal Name
1	Y	-
2	LG	-
3	SB	-
4	B	-

Connector No.	M251
Connector Name	WIRE TO WIRE
Connector Color	WHITE

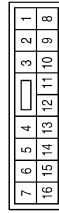

Terminal No.	Color of Wire	Signal Name
10	B	-
12	P	-
13	BR	-
14	SB	-
15	LG	-
16	Y	-

Connector No.	M221
Connector Name	FRONT HEATED SEAT SWITCH RH
Connector Color	BROWN



Terminal No.	Color of Wire	Signal Name
3	LG	-
4	BG	-
5	V	-
6	GR	-

Connector No.	E152
Connector Name	WIRE TO WIRE
Connector Color	WHITE



Terminal No.	Color of Wire	Signal Name
1G	G	-
6G	W	-

Connector No.	M253
Connector Name	2ND ROW HEATED SEAT SWITCH RH
Connector Color	WHITE



Terminal No.	Color of Wire	Signal Name
1	Y	-
2	BR	-
3	P	-
4	B	-

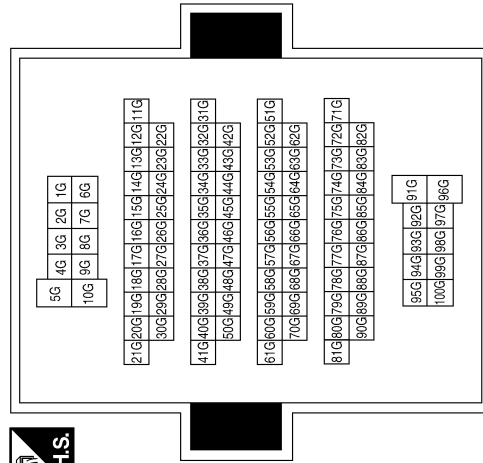

ABJIA0825GB

A
B
C
D
E
F
G
H
I
SE
K
L
M
N
O
P

HEATED SEAT SYSTEM

< WIRING DIAGRAM >

Terminal No.	Color of Wire	Signal Name
6A	LG	-(WITHOUT CLIMATE CONTROLLED SEAT)
6A	R	-(WITH CLIMATE CONTROLLED SEAT)
57A	SB	-(WITHOUT CLIMATE CONTROLLED SEAT)
57A	V	-(WITH CLIMATE CONTROLLED SEAT)
92A	LG	-
97A	BR	-

Connector No.	B63
Connector Name	JOINT CONNECTOR-B01
Connector Color	WHITE

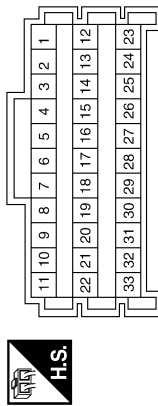

Terminal No.	Color of Wire	Signal Name
27	B	-
28	B	-

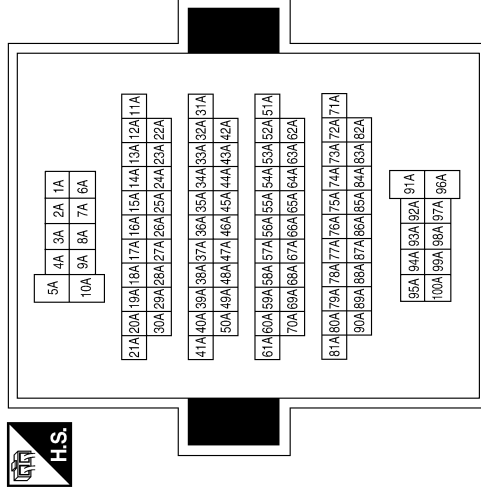

Connector No.	B69
Connector Name	WIRE TO WIRE
Connector Color	GRAY

Connector No.	B74
Connector Name	WIRE TO WIRE
Connector Color	WHITE

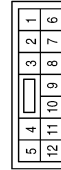

Terminal No.	Color of Wire	Signal Name
10	B	-(WITHOUT CLIMATE CONTROLLED SEAT)
10	BR	-(WITH CLIMATE CONTROLLED SEAT)
11	SB	-(WITHOUT CLIMATE CONTROLLED SEAT)
11	V	-(WITH CLIMATE CONTROLLED SEAT)
12	LG	-(WITHOUT CLIMATE CONTROLLED SEAT)
12	SB	-(WITH CLIMATE CONTROLLED SEAT)



Connector No.	B79
Connector Name	2ND ROW SEAT HEATER LH
Connector Color	WHITE

Terminal No.	Color of Wire	Signal Name
1	B	-
2	-	-
3	LG	-
4	BR	-
5	-	-
6	-	-

ABJIA0826GB

HEATED SEAT SYSTEM

< WIRING DIAGRAM >

Connector No.	B157
Connector Name	WIRE TO WIRE
Connector Color	WHITE

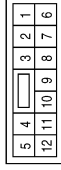

Terminal No.	Color of Wire	Signal Name
10	B	-(WITHOUT CLIMATE CONTROLLED SEAT)
10	SB	-(WITH CLIMATE CONTROLLED SEAT)
11	V	-(WITHOUT CLIMATE CONTROLLED SEAT)
11	BR	-(WITH CLIMATE CONTROLLED SEAT)
12	LG	-(WITHOUT CLIMATE CONTROLLED SEAT)
12	Y	-(WITH CLIMATE CONTROLLED SEAT)

Connector No.	B105
Connector Name	2ND ROW SEAT HEATER RH
Connector Color	WHITE



Terminal No.	Color of Wire	Signal Name
1	GR	-
2	-	-
3	LG	-
4	Y	-
5	-	-
6	-	-

Connector No.	B101
Connector Name	WIRE TO WIRE
Connector Color	WHITE

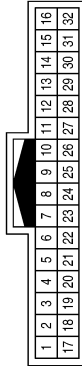

Terminal No.	Color of Wire	Signal Name
24	V	-(WITHOUT CLIMATE CONTROLLED SEAT)
24	BR	-(WITH CLIMATE CONTROLLED SEAT)

Connector No.	B216
Connector Name	FRONT SEAT HEATER (DRIVER SEAT)
Connector Color	WHITE



Terminal No.	Color of Wire	Signal Name
1	LG	-
2	R	-
3	B	-

Connector No.	B161
Connector Name	WIRE TO WIRE
Connector Color	WHITE



Terminal No.	Color of Wire	Signal Name
1	LG	-
2	Y	-
12	LG	-(WITHOUT CLIMATE CONTROLLED SEAT)
12	W	-(WITH CLIMATE CONTROLLED SEAT)

ABJIA0827GB

A
B
C
D
E
F
G
H
I
SE
K
L
M
N
O
P

HEATED SEAT SYSTEM

< WIRING DIAGRAM >

Connector No.	B315
Connector Name	FRONT SEAT HEATER (PASSENGER SEAT)
Connector Color	WHITE



Terminal No.	Color of Wire	Signal Name
1	LG	-
2	R	-
3	B	-

Connector No.	B300
Connector Name	WIRE TO WIRE
Connector Color	WHITE

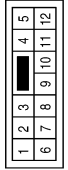

Terminal No.	Color of Wire	Signal Name
10	B	-(WITHOUT CLIMATE CONTROLLED SEAT)
10	SB	-(WITH CLIMATE CONTROLLED SEAT)
11	V	-(WITHOUT CLIMATE CONTROLLED SEAT)
11	BR	-(WITH CLIMATE CONTROLLED SEAT)
12	LG	-(WITHOUT CLIMATE CONTROLLED SEAT)
12	Y	-(WITH CLIMATE CONTROLLED SEAT)

Connector No.	B220
Connector Name	WIRE TO WIRE
Connector Color	WHITE

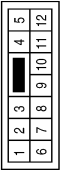

Terminal No.	Color of Wire	Signal Name
10	B	-(WITHOUT CLIMATE CONTROLLED SEAT)
10	BR	-(WITH CLIMATE CONTROLLED SEAT)
11	SB	-(WITHOUT CLIMATE CONTROLLED SEAT)
11	V	-(WITH CLIMATE CONTROLLED SEAT)
12	LG	-(WITHOUT CLIMATE CONTROLLED SEAT)
12	SB	-(WITH CLIMATE CONTROLLED SEAT)

ABJIA0839GB

CLIMATE CONTROLLED SEAT SYSTEM

< WIRING DIAGRAM >

CLIMATE CONTROLLED SEAT SYSTEM

Wiring Diagram

INFOID:000000009176469

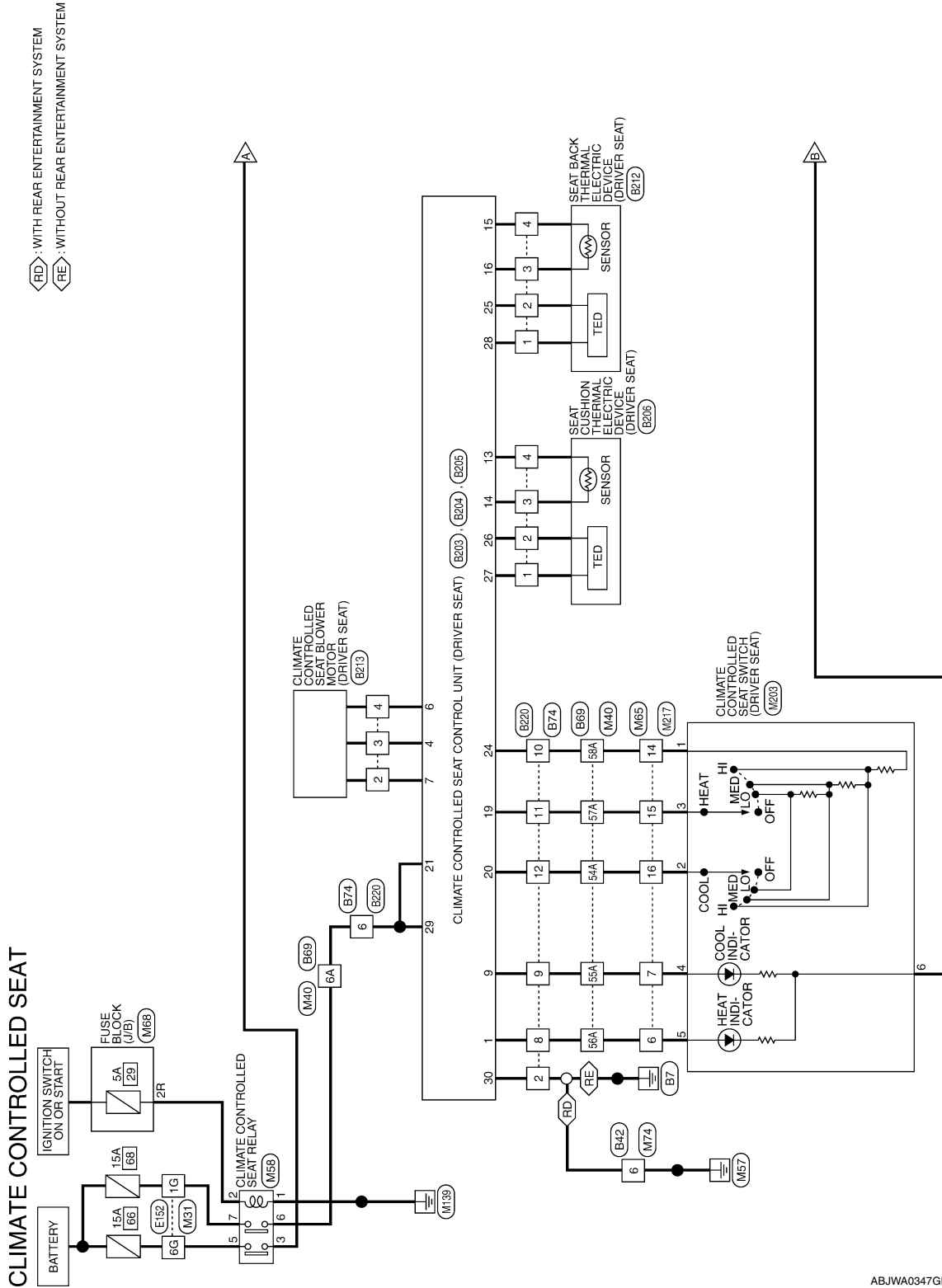

ABJWA0347GB

A
B
C
D
E
F
G
H
I
SE
K
L
M
N
O
P

CLIMATE CONTROLLED SEAT SYSTEM

< WIRING DIAGRAM >

RD : WITH REAR ENTERTAINMENT SYSTEM
RE : WITHOUT REAR ENTERTAINMENT SYSTEM

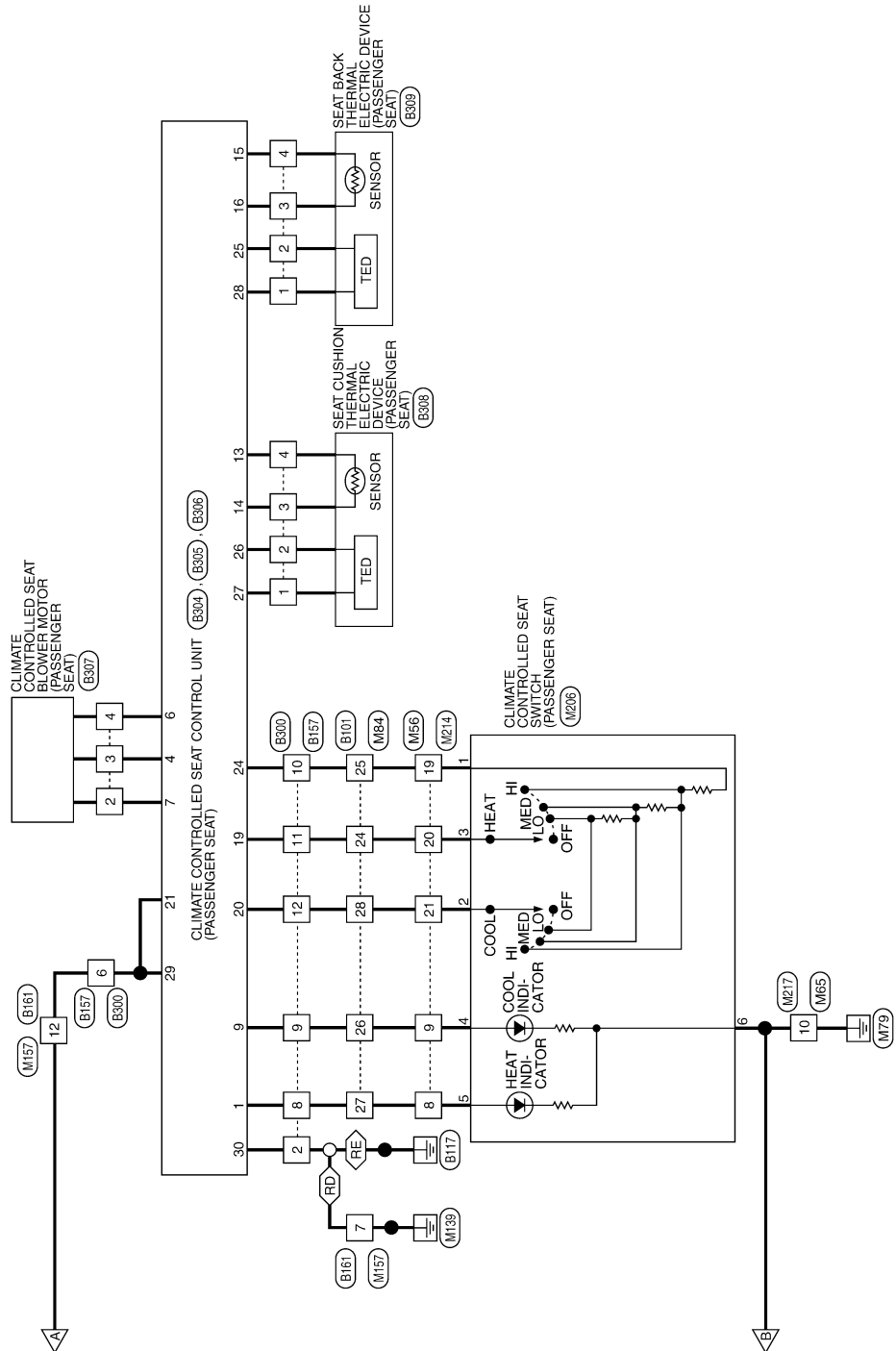

ABJWA0348GB

CLIMATE CONTROLLED SEAT SYSTEM

< WIRING DIAGRAM >

CLIMATE CONTROLLED SEAT CONNECTORS

Connector No.	M31
Connector Name	WIRE TO WIRE
Connector Color	WHITE

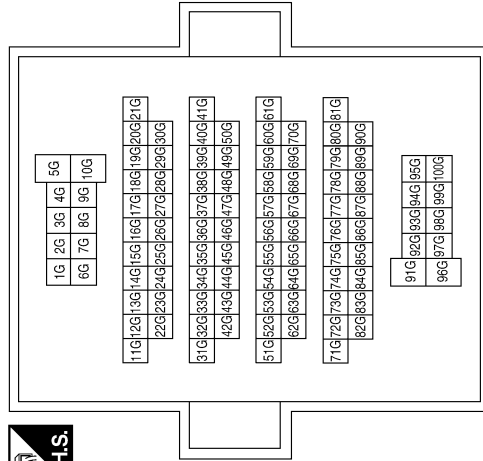

Connector No.	M40
Connector Name	WIRE TO WIRE
Connector Color	GRAY

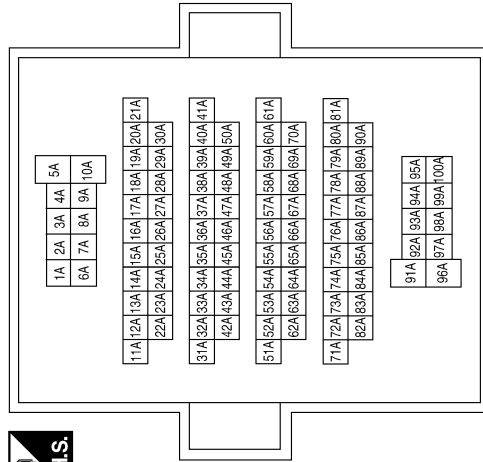

Connector No.	M56
Connector Name	WIRE TO WIRE
Connector Color	WHITE

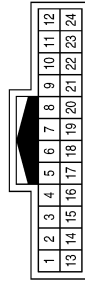

Terminal No.	Color of Wire	Signal Name
8	BG	-
9	W	-
19	W	-
20	R	-
21	V	-

Terminal No.	Color of Wire	Signal Name
1G	P	-(WITH CLIMATE CONTROLLED SEAT)
6G	R	-(WITH CLIMATE CONTROLLED SEAT)

Terminal No.	Color of Wire	Signal Name
6A	G	-(WITH CLIMATE CONTROLLED SEAT)
54A	W	-
55A	BG	-
56A	BR	-
57A	P	-(WITH CLIMATE CONTROLLED SEAT)
58A	G	-

A
B
C
D
E
F
G
H
I
SE
K
L
M
N
O
P

CLIMATE CONTROLLED SEAT SYSTEM

< WIRING DIAGRAM >

Connector No.	M58
Connector Name	CLIMATE CONTROLLED SEAT RELAY
Connector Color	BROWN



Terminal No.	Color of Wire	Signal Name
1	GR	-
2	LG	-
3	W	-
5	R	-
6	G	-
7	P	-

Connector No.	M65
Connector Name	WIRE TO WIRE
Connector Color	WHITE

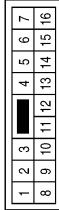

Terminal No.	Color of Wire	Signal Name
6	BR	- (WITH CLIMATE CONTROLLED SEAT)
7	BG	-
10	B	-
14	G	- (WITH CLIMATE CONTROLLED SEAT)
15	P	- (WITH CLIMATE CONTROLLED SEAT)
16	W	- (WITH CLIMATE CONTROLLED SEAT)

Connector No.	M68
Connector Name	FUSE BLOCK (J/B)
Connector Color	BROWN



Terminal No.	Color of Wire	Signal Name
2R	LG	-

Connector No.	M74
Connector Name	WIRE TO WIRE
Connector Color	BROWN



Terminal No.	Color of Wire	Signal Name
6	B	-

Connector No.	M84
Connector Name	WIRE TO WIRE
Connector Color	WHITE

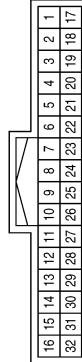

Terminal No.	Color of Wire	Signal Name
24	R	- (WITH CLIMATE CONTROLLED SEAT)
25	W	-
26	W	-
27	BG	-
28	V	-

Connector No.	M157
Connector Name	WIRE TO WIRE
Connector Color	WHITE

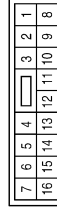

Terminal No.	Color of Wire	Signal Name
7	GR	-
12	W	- (WITH CLIMATE CONTROLLED SEAT)

CLIMATE CONTROLLED SEAT SYSTEM

< WIRING DIAGRAM >

Connector No.	M214
Connector Name	WIRE TO WIRE
Connector Color	WHITE

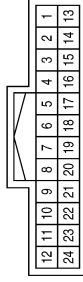

Terminal No.	Color of Wire	Signal Name
8	V	-
9	BG	-
19	SB	-
20	L	-
21	G	-

Connector No.	M206
Connector Name	CLIMATE CONTROLLED SEAT SWITCH (PASSENGER SEAT)
Connector Color	BROWN

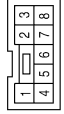

Terminal No.	Color of Wire	Signal Name
1	SB	-
2	G	-
3	L	-
4	BG	-
5	V	-
6	B	-

Connector No.	M203
Connector Name	CLIMATE CONTROLLED SEAT SWITCH (DRIVER SEAT)
Connector Color	WHITE

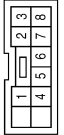

Terminal No.	Color of Wire	Signal Name
1	BG	-
2	V	-
3	P	-
4	BR	-
5	Y	-
6	B	-

Connector No.	E152
Connector Name	WIRE TO WIRE
Connector Color	WHITE

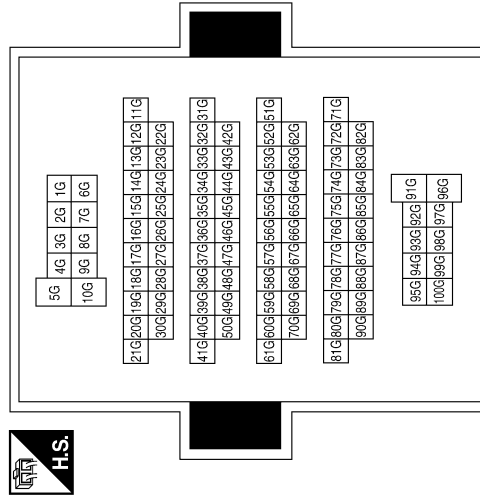

Connector No.	M217
Connector Name	WIRE TO WIRE
Connector Color	WHITE

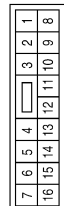

Terminal No.	Color of Wire	Signal Name
6	Y	-(WITH CLIMATE CONTROLLED SEAT)
7	BR	-(WITH CLIMATE CONTROLLED SEAT)
10	B	-
14	BG	-(WITH CLIMATE CONTROLLED SEAT)
15	P	-(WITH CLIMATE CONTROLLED SEAT)
16	V	-(WITH CLIMATE CONTROLLED SEAT)

AAJIA0217GB

A B C D E F G H I SE K L M N O P

CLIMATE CONTROLLED SEAT SYSTEM

< WIRING DIAGRAM >

Terminal No.	Color of Wire	Signal Name
6A	R	– (WITH CLIMATE CONTROLLED SEAT)
54A	SB	–
55A	LG	–
56A	Y	–
57A	V	– (WITH CLIMATE CONTROLLED SEAT)
58A	BR	–

Connector No.	B69
Connector Name	WIRE TO WIRE
Connector Color	GRAY

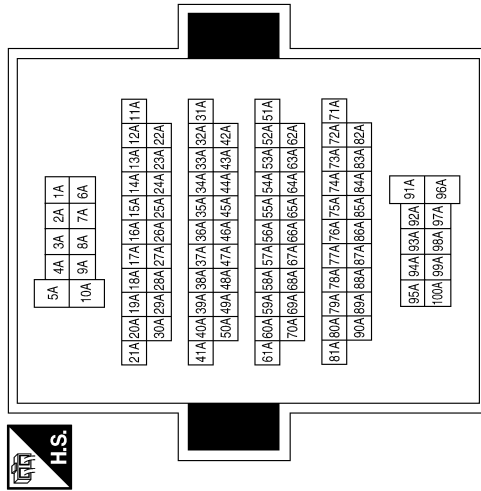

Connector No.	B42
Connector Name	WIRE TO WIRE
Connector Color	BROWN

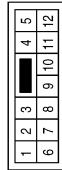

Terminal No.	Color of Wire	Signal Name
6	B	–



Connector No.	B101
Connector Name	WIRE TO WIRE
Connector Color	WHITE

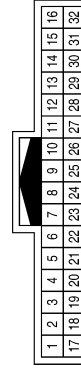

Terminal No.	Color of Wire	Signal Name
24	BR	– (WITH CLIMATE CONTROLLED SEAT)
25	SB	–
26	LG	–
27	Y	–
28	Y	–

Terminal No.	Color of Wire	Signal Name
2	B	– (WITH CLIMATE CONTROLLED SEAT)
6	R	–
8	Y	–
9	LG	–
10	BR	– (WITH CLIMATE CONTROLLED SEAT)
11	V	– (WITH CLIMATE CONTROLLED SEAT)
12	SB	– (WITH CLIMATE CONTROLLED SEAT)

Connector No.	B74
Connector Name	WIRE TO WIRE
Connector Color	WHITE

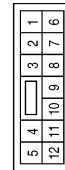

ABJIA0821GB

CLIMATE CONTROLLED SEAT SYSTEM

< WIRING DIAGRAM >

Connector No.	B161
Connector Name	WIRE TO WIRE
Connector Color	WHITE



1	2	3	4	5	6	7		
8	9	10	11	12	13	14	15	16

Terminal No.	Color of Wire	Signal Name
7	B	-
12	W	-(WITH CLIMATE CONTROLLED SEAT)

Terminal No.	Color of Wire	Signal Name
2	B	-
6	W	-
8	Y	-
9	LG	-
10	SB	-(WITH CLIMATE CONTROLLED SEAT)
11	BR	-(WITH CLIMATE CONTROLLED SEAT)
12	Y	-(WITH CLIMATE CONTROLLED SEAT)

Connector No.	B157
Connector Name	WIRE TO WIRE
Connector Color	WHITE



5	4	3	2	1		
12	11	10	9	8	7	6

Connector No.	B203
Connector Name	CLIMATE CONTROLLED SEAT CONTROL UNIT (DRIVER SEAT)
Connector Color	BLACK



1	2	3	4	5	6	7	8
9	10	11	12	13	14	15	16

Terminal No.	Color of Wire	Signal Name
1	LG	HEAT ON INDICATOR
2	-	-
3	-	-
4	P	BLOWER MOTOR SPEED CONTROL
5	-	-
6	G	BLOWER GND
7	R	BLOWER POWER
8	-	-
9	W	COOL ON INDICATOR

Terminal No.	Color of Wire	Signal Name
10	-	-
11	-	-
12	-	-
13	Y	CUSHION SENSOR GND
14	BR	CUSHION SENSOR SIGNAL
15	V	BACK SENSOR GND
16	L	BACK SENSOR SIGNAL

Connector No.	B204
Connector Name	CLIMATE CONTROLLED SEAT CONTROL UNIT (DRIVER SEAT)
Connector Color	BLACK



17	18	19	20
21	22	23	24

Terminal No.	Color of Wire	Signal Name
17	-	-
18	-	-
19	Y	HEAT SWITCH INPUT
20	V	COOL SWITCH INPUT
21	R	IGN RUN
22	-	-
23	-	-
24	G	HEAT/COOL SW RESISTOR PWR

ABJIA0822GB

A
B
C
D
E
F
G
H
I
SE
K
L
M
N
O
P

CLIMATE CONTROLLED SEAT SYSTEM

< WIRING DIAGRAM >

Connector No.	B212
Connector Name	SEAT BACK THERMAL ELECTRIC DEVICE (DRIVER SEAT)
Connector Color	WHITE

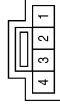

Terminal No.	Color of Wire	Signal Name
1	W	-
2	G	-
3	L	-
4	V	-

Connector No.	B206
Connector Name	SEAT CUSHION THERMAL ELECTRIC DEVICE (DRIVER SEAT)
Connector Color	WHITE

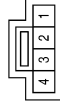

Terminal No.	Color of Wire	Signal Name
1	L	-
2	LG	-
3	BR	-
4	Y	-

Connector No.	B205
Connector Name	CLIMATE CONTROLLED SEAT CONTROL UNIT (DRIVER SEAT)
Connector Color	BLACK

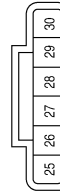

Terminal No.	Color of Wire	Signal Name
25	G	BACK TED +COOL /-HEAT
26	LG	CUSHION TED +COOL /-HEAT
27	L	CUSHION TED -COOL /+ HEAT
28	W	BACK TED -COOL /+HEAT
29	R	BAT (PTC)
30	B	MAIN GND

Connector No.	B300
Connector Name	WIRE TO WIRE
Connector Color	WHITE



Terminal No.	Color of Wire	Signal Name
2	B	-
6	W	-
8	Y	-
9	LG	-
10	SB	-(WITH CLIMATE CONTROLLED SEAT)
11	BR	-(WITH CLIMATE CONTROLLED SEAT)
12	Y	-(WITH CLIMATE CONTROLLED SEAT)

Connector No.	B220
Connector Name	WIRE TO WIRE
Connector Color	WHITE



Terminal No.	Color of Wire	Signal Name
2	B	-
6	R	-
8	Y	-
9	LG	-
10	BR	-(WITH CLIMATE CONTROLLED SEAT)
11	V	-(WITH CLIMATE CONTROLLED SEAT)
12	SB	-(WITH CLIMATE CONTROLLED SEAT)

Connector No.	B213
Connector Name	CLIMATE CONTROLLED SEAT BLOWER MOTOR (DRIVER SEAT)
Connector Color	WHITE



Terminal No.	Color of Wire	Signal Name
1	-	-
2	R	-
3	P	-
4	G	-
5	-	-

AAJIA0220GB

CLIMATE CONTROLLED SEAT SYSTEM

< WIRING DIAGRAM >

Connector No.	B305
Connector Name	CLIMATE CONTROLLED SEAT CONTROL UNIT (PASSENGER SEAT)
Connector Color	BLACK



Terminal No.	Color of Wire	Signal Name
17	-	-
18	-	-
19	Y	HEAT SWITCH INPUT
20	V	COOL SWITCH INPUT
21	R	IGN RUN
22	-	-
23	-	-
24	G	HEAT/COOL SW RESISTOR PWR

Connector No.	B304
Connector Name	CLIMATE CONTROLLED SEAT CONTROL UNIT (PASSENGER SEAT)
Connector Color	BLACK

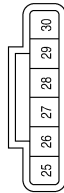

Terminal No.	Color of Wire	Signal Name
25	G	BACK TED + COOL / - HEAT
26	LG	CUSHION TED + COOL / - HEAT
27	L	CUSHION TED - COOL / + HEAT
28	W	BACK TED - COOL / + HEAT
29	R	BAT (PTC)
30	B	MAIN GND

Connector No.	B307
Connector Name	CLIMATE CONTROLLED SEAT BLOWER MOTOR (PASSENGER SEAT)
Connector Color	WHITE



Terminal No.	Color of Wire	Signal Name
1	-	-
2	R	-
3	P	-
4	G	-
5	-	-

Terminal No.	Color of Wire	Signal Name
6	G	BLOWER GND
7	R	BLOWER POWER
8	-	-
9	W	COOL ON INDICATOR
10	-	-
11	-	-
12	-	-

Terminal No.	Color of Wire	Signal Name
13	Y	CUSHION SENSOR GND
14	BR	CUSHION SENSOR SIGNAL
15	V	BACK SENSOR GND
16	L	BACK SENSOR SIGNAL

Connector No.	B306
Connector Name	CLIMATE CONTROLLED SEAT CONTROL UNIT (PASSENGER SEAT)
Connector Color	BLACK

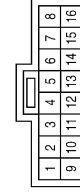

Terminal No.	Color of Wire	Signal Name
1	LG	HEAT ON INDICATOR
2	-	-
3	-	-
4	P	BLOWER MOTOR SPEED CONTROL
5	-	-

AAJIA0221GB

A
B
C
D
E
F
G
H
I
SE
K
L
M
N
O
P

CLIMATE CONTROLLED SEAT SYSTEM

< WIRING DIAGRAM >

Connector No.	B309
Connector Name	SEAT BACK THERMAL ELECTRIC DEVICE (PASSENGER SEAT)
Connector Color	WHITE

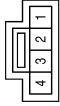

Terminal No.	Color of Wire	Signal Name
1	W	-
2	G	-
3	L	-
4	V	-

Connector No.	B308
Connector Name	SEAT CUSHION THERMAL ELECTRIC DEVICE (PASSENGER SEAT)
Connector Color	WHITE

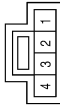

Terminal No.	Color of Wire	Signal Name
1	L	-
2	LG	-
3	BR	-
4	Y	-

ABJIA0704GB

DIAGNOSIS AND REPAIR WORK FLOW

< BASIC INSPECTION >

BASIC INSPECTION

DIAGNOSIS AND REPAIR WORK FLOW

Work Flow

INFOID:000000009176470

OVERALL SEQUENCE

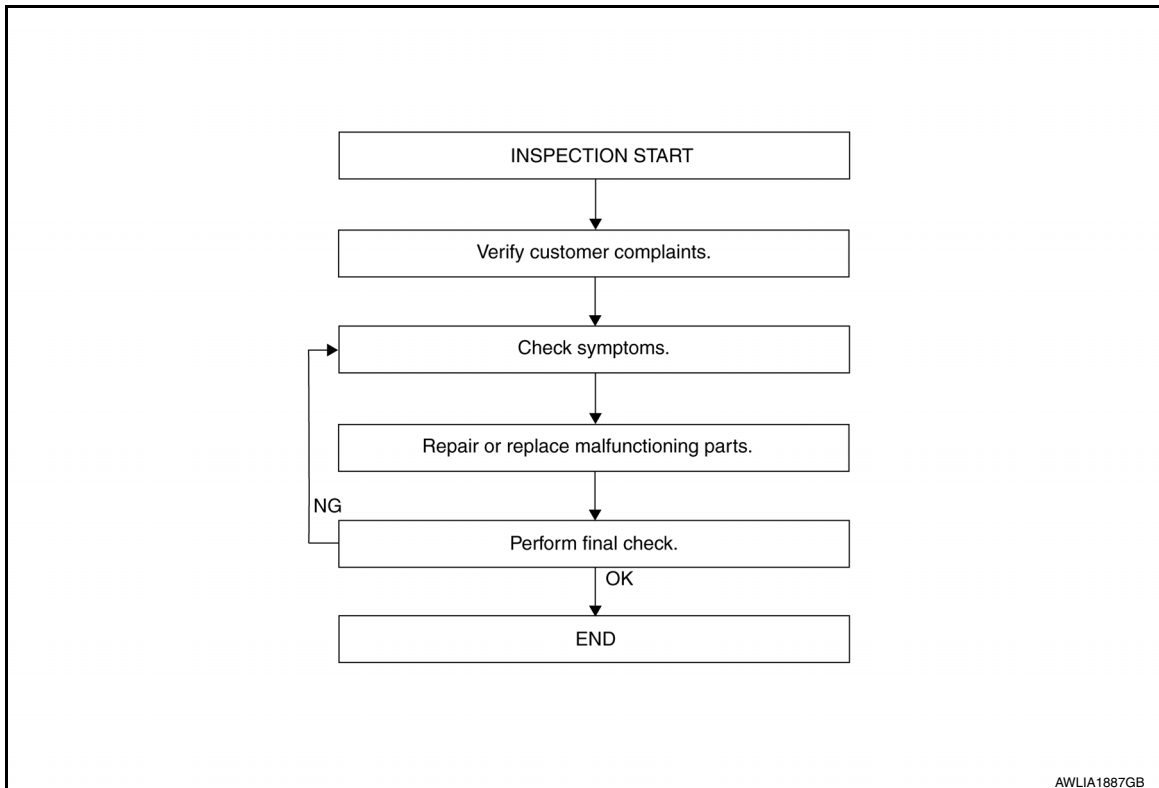

DETAILED FLOW

1. REVIEW CUSTOMER COMPLAINT

Review customer complaint. Try to obtain detailed information about the conditions when the symptom occurs.

>> GO TO 2.

2. VERIFY THE SYMPTOM

Verify the symptom by performing an operational check. Refer to [SE-12. "CLIMATE CONTROLLED SEAT SYSTEM : System Description"](#).

>> GO TO 3.

3. PERFORM TROUBLE DIAGNOSIS BY SYMPTOM

Diagnose the vehicle by performing the appropriate trouble diagnosis. Refer to [SE-70. "Symptom Table"](#).

>> GO TO 4.

4. REPAIR OR REPLACE MALFUNCTIONING PARTS

Repair or replace the specific parts.

>> GO TO 5.

5. FINAL CHECK

DIAGNOSIS AND REPAIR WORK FLOW

< BASIC INSPECTION >

Perform a final inspection of the system.

Is the inspection result normal?

YES >> Inspection End.

NO >> GO TO 2.

POWER SUPPLY AND GROUND CIRCUIT

< DTC/CIRCUIT DIAGNOSIS >

DTC/CIRCUIT DIAGNOSIS

POWER SUPPLY AND GROUND CIRCUIT CLIMATE CONTROLLED SEAT CONTROL UNIT

CLIMATE CONTROLLED SEAT CONTROL UNIT : Diagnosis Procedure INFOID:000000009176471

Regarding Wiring Diagram information, refer to [SE-37, "Wiring Diagram"](#).

DRIVER SIDE

1. CHECK FUSE

Check if any of the following fuses are blown.

Signal name	Fuse No.
Battery power supply	68 (15A)
IGN power supply	29 (5A)

Is the fuse blown?

- YES >> Replace the blown fuse after repairing the affected circuit.
NO >> GO TO 2.

2. CHECK CLIMATE CONTROLLED SEAT CONTROL UNIT (DRIVER SIDE) POWER SUPPLY

1. Turn ignition switch OFF.
2. Disconnect climate controlled seat control unit (driver side) connector.
3. Turn ignition switch ON.
4. Check voltage between climate controlled seat control unit (driver side) harness connector and ground.

(+)		(-)	Voltage (V) (Approx.)
Connector	Terminal		
B204	21	Ground	Battery voltage
B205	29		

Is the inspection result normal?

- YES >> GO TO 7.
NO >> GO TO 3.

3. CHECK CLIMATE CONTROLLED SEAT CONTROL UNIT (DRIVER SIDE) POWER SUPPLY CIRCUIT

1. Turn ignition switch OFF.
2. Disconnect climate controlled seat relay.
3. Check continuity between climate controlled seat control unit (driver side) harness connector and climate controlled seat relay harness connector.

Climate controlled seat control unit (driver side)		Climate controlled seat relay		Continuity
Connector	Terminal	Connector	Terminal	
B204	21	M58	6	Yes
B205	29			

4. Check continuity between climate controlled seat control unit (driver side) harness connector and ground.

Climate controlled seat control unit (driver side)		Ground	Continuity
Connector	Terminal		
B204	21		No
B205	29		

POWER SUPPLY AND GROUND CIRCUIT

< DTC/CIRCUIT DIAGNOSIS >

Is the inspection result normal?

- YES >> GO TO 4.
NO >> Repair or replace harness or connector.

4. CHECK CLIMATE CONTROLLED SEAT RELAY POWER SUPPLY CIRCUIT

1. Turn ignition switch ON.
2. Check voltage between climate controlled seat relay harness connector and ground.

(+)		(-)	Voltage (V) (Approx.)
Connector	Terminal		
M58	2	Ground	Battery voltage
	7		

Is the inspection result normal?

- YES >> GO TO 5.
NO >> Repair or replace harness or connector.

5. CHECK CLIMATE CONTROLLED SEAT RELAY GROUND CIRCUIT

1. Turn ignition switch OFF.
2. Check continuity between climate controlled seat relay harness connector and ground.

Climate controlled seat relay		Ground	Continuity
Connector	Terminal		
M58	1		Yes

Is the inspection result normal?

- YES >> GO TO 6.
NO >> Repair or replace harness.

6. CHECK CLIMATE CONTROLLED SEAT RELAY

Check climate controlled seat relay.

Refer to [SE-52. "CLIMATE CONTROLLED SEAT CONTROL UNIT : Component Inspection"](#).

Is the inspection result normal?

- YES >> GO TO 8.
NO >> Replace climate controlled seat relay.

7. CHECK CLIMATE CONTROLLED SEAT CONTROL UNIT (DRIVER SIDE) GROUND CIRCUIT

1. Turn ignition switch OFF.
2. Check continuity between climate control unit (driver side) harness connector and ground.

Climate controlled seat control unit (driver side)		Ground	Continuity
Connector	Terminal		
B205	30		Yes

Is the inspection result normal?

- YES >> Check intermittent incident. Refer to [GI-49. "Intermittent Incident"](#).
NO >> Repair or replace harness or connector.

PASSENGER SIDE

1. CHECK FUSE

Check if any of the following fuses are blown.

Signal name	Fuse No.
Battery power supply	66 (15A)
IGN power supply	29 (5A)

POWER SUPPLY AND GROUND CIRCUIT

< DTC/CIRCUIT DIAGNOSIS >

Is the fuse blown?

- YES >> Replace the blown fuse after repairing the affected circuit.
 NO >> GO TO 2.

2. CHECK CLIMATE CONTROLLED SEAT CONTROL UNIT (PASSENGER SIDE) POWER SUPPLY

1. Turn ignition switch OFF.
2. Disconnect climate controlled seat control unit (passenger side) connector.
3. Turn ignition switch ON.
4. Check voltage between climate controlled seat control unit (passenger side) harness connector and ground.

(+)		(-)	Voltage (V) (Approx.)
Climate controlled seat control unit (passenger side)			
Connector	Terminal	Ground	Battery voltage
B304	21		
B305	29		

Is the inspection result normal?

- YES >> GO TO 7.
 NO >> GO TO 3.

3. CHECK CLIMATE CONTROLLED SEAT CONTROL UNIT (PASSENGER SIDE) POWER SUPPLY CIRCUIT

1. Turn ignition switch OFF.
2. Disconnect climate controlled seat relay.
3. Check continuity between climate controlled seat control unit (passenger side) harness connector and climate controlled seat relay harness connector.

Climate controlled seat control unit (passenger side)		Climate controlled seat relay		Continuity
Connector	Terminal	Connector	Terminal	
B304	21	M58	3	Yes
B305	29			

4. Check continuity between climate controlled seat control unit (passenger side) harness connector and ground.

Climate controlled seat control unit (passenger side)		Ground	Continuity
Connector	Terminal		
B304	21		No
B305	29		

Is the inspection result normal?

- YES >> GO TO 4.
 NO >> Repair or replace harness or connector.

4. CHECK CLIMATE CONTROLLED SEAT RELAY POWER SUPPLY CIRCUIT

1. Turn ignition switch ON.
2. Check voltage between climate controlled seat relay harness connector and ground.

(+)		(-)	Voltage (V) (Approx.)
Climate controlled seat relay			
Connector	Terminal	Ground	Battery voltage
M58	2		
	5		

Is the inspection result normal?

- YES >> GO TO 5.

CLIMATE CONTROLLED SEAT SWITCH

< DTC/CIRCUIT DIAGNOSIS >

CLIMATE CONTROLLED SEAT SWITCH

Component Function Check

INFOID:000000009176473

1. CHECK CLIMATE CONTROLLED SEAT SWITCH FUNCTION

Check that climate controlled seat activates when operating climate controlled seat control switch.

Is the inspection result normal?

- YES >> Climate controlled seat switch is OK.
 NO >> Refer to [SE-53, "Diagnosis Procedure"](#).

Diagnosis Procedure

INFOID:000000009176474

Regarding Wiring Diagram information, refer to [SE-37, "Wiring Diagram"](#).

1. CHECK CLIMATE CONTROLLED SEAT CONTROL UNIT INPUT SIGNAL

- Turn ignition switch ON.
- Check voltage between climate controlled seat control unit harness connector and ground.

(+)		(-)	Condition	Voltage (V) (Approx.)	
Climate controlled seat control unit					
Connector	Terminal				
Driver side	B204	20	Climate controlled seat switch (driver side)	COOL HI	2.6 - 4.2
				COOL MID	1.6 - 2.5
				COOL LO	0.8 - 1.5
		OFF		0	
		19	Climate controlled seat switch (driver side)	HEAT HI	2.6 - 4.2
				HEAT MID	1.6 - 2.5
HEAT LO	0.8 - 1.5				
OFF		0			
Passenger side	B304	20	Climate controlled seat switch (passenger seat)	COOL HI	2.6 - 4.2
				COOL MID	1.6 - 2.5
				COOL LO	0.8 - 1.5
		OFF		0	
		19	Climate controlled seat switch (passenger seat)	HEAT HI	2.6 - 4.2
				HEAT MID	1.6 - 2.5
HEAT LO	0.8 - 1.5				
OFF		0			

Is the inspection result normal?

- YES >> Inspection End.
 NO-1 >> HEAT or COOL mode is NG. GO TO 2.
 NO-2 >> HEAT and COOL mode are NG. GO TO 3.

2. CHECK CLIMATE CONTROLLED SEAT SWITCH CIRCUIT

- Turn ignition switch OFF.
- Disconnect climate controlled seat switch connector and climate controlled seat control unit connector.
- Check continuity between climate controlled seat switch harness connector and climate controlled seat control unit harness connector.

CLIMATE CONTROLLED SEAT SWITCH

< DTC/CIRCUIT DIAGNOSIS >

Climate controlled seat switch			Climate controlled seat control unit		Continuity
Connector		Terminal	Connector	Terminal	
Driver side	COOL	M203	B204	2	Yes
	HEAT			3	
Passenger side	COOL	M206	B304	2	
	HEAT			3	

4. Check continuity between climate controlled seat switch harness connector and ground.

Climate controlled seat switch			Terminal	Ground	Continuity
Connector					
Driver side	COOL	M203	2	Ground	No
	HEAT		3		
Passenger side	COOL	M206	2		
	HEAT		3		

Is the inspection result normal?

YES >> GO TO 5.

NO >> Repair or replace harness.

3. CHECK CLIMATE CONTROLLED SEAT SWITCH POWER SUPPLY

1. Turn ignition switch OFF.
2. Disconnect climate controlled seat switch connector.
3. Turn ignition switch ON.
4. Check voltage between climate controlled seat switch harness connector and ground.

Climate controlled seat switch		Terminal	(-)	Voltage (V) (Approx.)
Connector				
Driver side	M203	1	Ground	12
Passenger side	M206			

Is the inspection result normal?

YES >> GO TO 5.

NO >> GO TO 4.

4. CHECK CLIMATE CONTROLLED SEAT SWITCH POWER SUPPLY CIRCUIT

1. Turn ignition switch OFF.
2. Disconnect climate controlled seat control unit connector.
3. Check continuity between climate controlled seat switch harness connector and climate controlled seat control unit harness connector.

Climate controlled seat switch		Terminal	Climate controlled seat control unit		Continuity
Connector			Connector	Terminal	
Driver side	M203	1	B204	24	Yes
Passenger side	M206		B304		

4. Check continuity between climate controlled seat switch harness connector and ground.

Climate controlled seat switch			Terminal	Ground	Continuity
Connector					
Driver side	M203	1	Ground	No	
Passenger side	M206				

Is the inspection result normal?

CLIMATE CONTROLLED SEAT SWITCH

< DTC/CIRCUIT DIAGNOSIS >

- YES >> Replace climate controlled seat control unit. Refer to [SE-86. "Removal and Installation"](#).
NO >> Repair or replace harness.

5.CHECK CLIMATE CONTROLLED SEAT SWITCH

Check climate controlled seat switch.
Refer to [SE-55. "Component Inspection"](#).

Is the inspection result normal?

- YES >> Check intermittent incident. Refer to [GI-49. "Intermittent Incident"](#).
NO >> Replace climate controlled seat switch. Refer to [IP-18. "Removal and Installation"](#).

Component Inspection

INFOID:000000009176475

1.CHECK CLIMATE CONTROLLED SEAT SWITCH

1. Turn ignition switch OFF.
2. Disconnect climate controlled seat switch connector.
3. Check the continuity between climate controlled seat switch terminals under the following terminals.

Terminal		Condition		Continuity	
2	1	Climate controlled seat switch	COOL mode	ON	Yes
				OFF	No
3		HEAT mode	ON	Yes	
			OFF	No	

Is the inspection result normal?

- YES >> Inspection End.
NO >> Replace climate controlled seat switch. Refer to [IP-18. "Removal and Installation"](#).

A
B
C
D
E
F
G
H
I
K
L
M
N
O
P

SE

SEATBACK THERMAL ELECTRIC DEVICE

< DTC/CIRCUIT DIAGNOSIS >

SEATBACK THERMAL ELECTRIC DEVICE

Component Function Check

INFOID:000000009176476

1. CHECK SEATBACK THERMAL ELECTRIC DEVICE FUNCTION

Check whether or not the temperature of the seatback thermal electric device changes in accordance with the HEAT or COOL switch operation of the climate controlled seat control switch.

Is the inspection result normal?

- YES >> Inspection End.
 NO >> Refer to [SE-56, "Diagnosis Procedure"](#).

Diagnosis Procedure

INFOID:000000009176477

Regarding Wiring Diagram information, refer to [SE-37, "Wiring Diagram"](#).

1. CHECK SEATBACK THERMAL ELECTRIC DEVICE INPUT SIGNAL

1. Turn ignition switch ON.
2. Check voltage between seatback thermal electric device harness connector and ground.

(+)		(-)	Condition	Voltage (V) (Approx.)	
Seatback thermal electric device					
Connector	Terminal				
Driver side	B212	Ground	Climate controlled seat switch	HEAT or COOL	0 - 12*
				Other than above	0
			Climate controlled seat switch	HEAT or COOL	0 - 12*
				Other than above	0
Passenger side	B309	Ground	Climate controlled seat switch	HEAT or COOL	0 - 12*
				Other than above	0
			Climate controlled seat switch	HEAT or COOL	0 - 12*
				Other than above	0

*:It changes between 12 and 0 V

NOTE:

Wait 1 minute or more after the activation start, and then start the measurement.

Is the inspection result normal?

- YES >> Replace seatback thermal electric device. Refer to [SE-88, "Seatback Thermal Electric Device"](#).
 NO >> GO TO 2.

2. CHECK SEATBACK THERMAL ELECTRIC DEVICE CIRCUIT

1. Turn ignition switch OFF.
2. Disconnect climate controlled seat control unit connector and seatback thermal electric device connector.
3. Check continuity between climate controlled seat control unit harness connector and seatback thermal electric device harness connector.

Climate controlled seat control unit		Seatback thermal electric device		Continuity
Connector	Terminal	Connector	Terminal	
Driver side	B205	B212	28	1
			25	2
Passenger side	B305	B309	28	1
			25	2

4. Check continuity between climate controlled seat control unit harness connector and ground.

SEATBACK THERMAL ELECTRIC DEVICE

< DTC/CIRCUIT DIAGNOSIS >

Climate controlled seat control unit			Ground	Continuity		
Connector		Terminal		No		
Driver side	B205	28	Ground		No	
		25				
Passenger side	B305	28				Ground
		25				

Is the inspection result normal?

- YES >> Replace climate controlled seat control unit. Refer to [SE-86, "Removal and Installation"](#).
- NO >> Repair or replace harness.

A
B
C
D
E
F
G
H
I
K
L
M
N
O
P

SE

SEATBACK THERMAL ELECTRIC DEVICE SENSOR

< DTC/CIRCUIT DIAGNOSIS >

SEATBACK THERMAL ELECTRIC DEVICE SENSOR

Component Function Check

INFOID:000000009176478

1. CHECK SEATBACK THERMAL ELECTRIC DEVICE SENSOR FUNCTION

Check whether or not the temperature of the seatback thermal electric device changes in accordance with the HEAT or COOL switch operation of the climate controlled seat control switch.

Is the inspection result normal?

- YES >> Inspection End.
- NO >> Refer to [SE-58, "Diagnosis Procedure"](#).

Diagnosis Procedure

INFOID:000000009176479

Regarding Wiring Diagram information, refer to [SE-37, "Wiring Diagram"](#).

1. CHECK SEATBACK THERMAL ELECTRIC DEVICE SENSOR SIGNAL

1. Turn ignition switch ON.
2. Check voltage between seatback thermal electric device harness connector and ground.

(+)		Terminal	(-)	Condition	Voltage (V) (Approx.)
Seatback thermal electric device					
Connector					
Driver side	B212	3	Ground	Climate controlled seat operated	1 - 5
Passenger side	B309				

Is the inspection result normal?

- YES >> GO TO 3.
- NO >> GO TO 2.

2. CHECK SEATBACK THERMAL ELECTRIC DEVICE SENSOR CIRCUIT

1. Turn ignition switch OFF.
2. Disconnect climate controlled seat control unit connector and seatback thermal electric device connector.
3. Check continuity between climate controlled seat control unit harness connector and seatback thermal electric device harness connector.

Climate controlled seat control unit		Terminal	Seatback thermal electric device		Continuity
Connector			Connector	Terminal	
Driver side	B203	16	B212	3	Yes
Passenger side	B303		B309		

4. Check continuity between climate controlled seat control unit harness connector and ground.

Climate controlled seat control unit		Terminal	Ground	Continuity
Connector				
Driver side	B203	16		No
Passenger side	B303			

Is the inspection result normal?

- YES >> Replace climate controlled seat control unit. Refer to [SE-86, "Removal and Installation"](#).
- NO >> Repair or replace harness.

3. CHECK SEATBACK THERMAL ELECTRIC DEVICE SENSOR GROUND CIRCUIT

1. Turn ignition switch OFF.
2. Disconnect climate controlled seat control unit connector and seatback thermal electric device connector.

SEATBACK THERMAL ELECTRIC DEVICE SENSOR

< DTC/CIRCUIT DIAGNOSIS >

3. Check continuity between climate controlled seat control unit harness connector and seatback thermal electric device harness connector.

Climate controlled seat control unit		Seatback thermal electric device		Continuity
Connector	Terminal	Connector	Terminal	
Driver side	B203	15	B212	Yes
Passenger side	B303		B309	

4. Check continuity between climate controlled seat control unit harness connector and ground.

Climate controlled seat control unit		Ground	Continuity
Connector	Terminal		
Driver side	B203	15	No
Passenger side	B303		

Is the inspection result normal?

YES >> GO TO 4.

NO >> Repair or replace harness.

4. CHECK SEATBACK THERMAL ELECTRIC DEVICE SENSOR

Check seatback thermal electric device sensor.

Refer to [SE-59, "Component Inspection"](#).

Is the inspection result normal?

YES >> Check intermittent incident. Refer to [GI-49, "Intermittent Incident"](#).

NO >> Replace seatback thermal electric device. [SE-88, "Seatback Thermal Electric Device"](#).

Component Inspection

INFOID:000000009176480

1. CHECK SEATBACK THERMAL ELECTRIC DEVICE SENSOR

1. Turn ignition switch OFF.
2. Disconnect seatback thermal electric device connector.
3. Check resistance between seatback thermal electric device terminals.

Seatback thermal electric device		Resistance (Approx.)
Terminal		
3	4	1000Ω*

* : When sensor temperature is 25°C (77°F).

Is the inspection result normal?

YES >> Inspection End.

NO >> Replace seatback thermal electric device. Refer to [SE-88, "Seatback Thermal Electric Device"](#).

SEAT CUSHION THERMAL ELECTRIC DEVICE

< DTC/CIRCUIT DIAGNOSIS >

SEAT CUSHION THERMAL ELECTRIC DEVICE

Component Function Check

INFOID:000000009176481

1. CHECK SEAT CUSHION THERMAL ELECTRIC DEVICE FUNCTION

Check whether or not the temperature of the seat cushion thermal electric device changes in accordance with the HEAT or COOL switch operation of the climate controlled seat control switch.

Is the inspection result normal?

- YES >> Inspection End.
NO >> Refer to [SE-60, "Diagnosis Procedure"](#).

Diagnosis Procedure

INFOID:000000009176482

Regarding Wiring Diagram information, refer to [SE-37, "Wiring Diagram"](#).

1. CHECK SEAT CUSHION THERMAL ELECTRIC DEVICE SIGNAL

1. Turn ignition switch ON.
2. Check voltage between seat cushion thermal electric device harness connector and ground.

(+)		(-)	Condition	Voltage (V) (Approx.)	
Seat cushion thermal electric device					
Connector	Terminal				
Driver side	B206	Ground	Climate controlled seat switch	HEAT or COOL	0 - 12*
				Other than above	0
			Climate controlled seat switch	HEAT or COOL	0 - 12*
				Other than above	0
Passenger side	B308	Ground	Climate controlled seat switch	HEAT or COOL	0 - 12*
				Other than above	0
			Climate controlled seat switch	HEAT or COOL	0 - 12*
				Other than above	0

*:It changes between 12 and 0 V

NOTE:

Wait 1 minute or more after the activation start, and then start the measurement.

Is the inspection result normal?

- YES >> Replace seat cushion thermal electric device. Refer to [SE-88, "Seat Cushion Thermal Electric Device"](#).
NO >> GO TO 2.

2. CHECK SEAT CUSHION THERMAL ELECTRIC DEVICE CIRCUIT

1. Turn ignition switch OFF.
2. Disconnect climate controlled seat control unit connector and seat cushion thermal electric device connector.
3. Check continuity between climate controlled seat control unit harness connector and seat cushion thermal electric device harness connector.

SEAT CUSHION THERMAL ELECTRIC DEVICE

< DTC/CIRCUIT DIAGNOSIS >

Climate controlled seat control unit		Seat cushion thermal electric device		Continuity
Connector	Terminal	Connector	Terminal	
Driver side	B205	27	B206	1
		26		2
Passenger side	B305	27	B308	1
		26		2

4. Check continuity between climate controlled seat control unit harness connector and ground.

Climate controlled seat control unit		Ground	Continuity
Connector	Terminal		
Driver side	B205	27	No
		26	
Passenger side	B305	27	
		26	

Is the inspection result normal?

YES >> Replace climate controlled seat control unit. Refer to [SE-86, "Removal and Installation"](#).

NO >> Repair or replace harness.

SE

SEAT CUSHION THERMAL ELECTRIC DEVICE SENSOR

< DTC/CIRCUIT DIAGNOSIS >

SEAT CUSHION THERMAL ELECTRIC DEVICE SENSOR

Component Function Check

INFOID:000000009176483

1. CHECK SEAT CUSHION THERMAL ELECTRIC DEVICE SENSOR FUNCTION

Check whether or not the temperature of the seat cushion thermal electric device changes in accordance with the HEAT or COOL switch operation of the climate controlled seat control switch.

Is the inspection result normal?

- YES >> Inspection End.
- NO >> Refer to [SE-62, "Diagnosis Procedure"](#).

Diagnosis Procedure

INFOID:000000009176484

Regarding Wiring Diagram information, refer to [SE-37, "Wiring Diagram"](#).

1. CHECK SEAT CUSHION THERMAL ELECTRIC DEVICE SENSOR SIGNAL

1. Turn ignition switch ON.
2. Check voltage between seat cushion thermal electric device harness connector and ground.

(+)		Terminal	(-)	Condition	Voltage (V) (Approx.)
Seat cushion thermal electric device					
Connector					
Driver side	B206	3	Ground	Climate controlled seat operated	1 - 5
Passenger side	B308				

Is the inspection result normal?

- YES >> GO TO 3.
- NO >> GO TO 2.

2. CHECK SEAT CUSHION THERMAL ELECTRIC DEVICE SENSOR CIRCUIT

1. Turn ignition switch OFF.
2. Disconnect climate controlled seat control unit connector and seat cushion thermal electric device connector.
3. Check continuity between climate controlled seat control unit harness connector and seat cushion thermal electric device harness connector.

Climate controlled seat control unit		Terminal	Seat cushion thermal electric device		Continuity
Connector			Connector	Terminal	
Driver side	B203	14	B206	3	Yes
Passenger side	B303		B308		

4. Check continuity between climate controlled seat control unit harness connector and ground.

Climate controlled seat control unit		Terminal	Ground	Continuity
Connector				
Driver side	B203	14		No
Passenger side	B303			

Is the inspection result normal?

- YES >> Replace climate controlled seat control unit. Refer to [SE-86, "Removal and Installation"](#).
- NO >> Repair or replace harness.

3. CHECK SEAT CUSHION THERMAL ELECTRIC DEVICE SENSOR GROUND CIRCUIT

1. Turn ignition switch OFF.

SEAT CUSHION THERMAL ELECTRIC DEVICE SENSOR

< DTC/CIRCUIT DIAGNOSIS >

2. Disconnect climate controlled seat control unit connector and seat cushion thermal electric device connector.
3. Check continuity between climate controlled seat control unit harness connector and seat cushion thermal electric device harness connector.

Climate controlled seat control unit		Seat cushion thermal electric device		Continuity
Connector	Terminal	Connector	Terminal	
Driver side	B203	13	B206	Yes
Passenger side	B303		B308	

4. Check continuity between climate controlled seat control unit harness connector and ground.

Climate controlled seat control unit		Ground	Continuity
Connector	Terminal		
Driver side	B203	13	No
Passenger side	B303		

Is the inspection result normal?

YES >> GO TO 4.

NO >> Repair or replace harness.

4. CHECK SEAT CUSHION THERMAL ELECTRIC DEVICE SENSOR

Check seat cushion thermal electric device sensor. Refer to [SE-63, "Component Inspection"](#).

Is the inspection result normal?

YES >> Check intermittent incident. Refer to [GI-49, "Intermittent Incident"](#).

NO >> Replace seat cushion thermal electric device. [SE-88, "Seat Cushion Thermal Electric Device"](#).

Component Inspection

INFOID:000000009176485

1. CHECK SEAT CUSHION THERMAL ELECTRIC DEVICE SENSOR

1. Turn ignition switch OFF.
2. Disconnect seat cushion thermal electric device connector.
3. Check resistance between seat cushion thermal electric device terminals.

Seat cushion thermal electric device		Resistance (Approx.)
Terminal		
3	4	1000Ω*

* : When sensor temperature is 25°C (77°F).

Is the inspection result normal?

YES >> Inspection End.

NO >> Replace seat cushion thermal electric device. Refer to [SE-88, "Seat Cushion Thermal Electric Device"](#).

CLIMATE CONTROLLED SEAT BLOWER MOTOR

< DTC/CIRCUIT DIAGNOSIS >

CLIMATE CONTROLLED SEAT BLOWER MOTOR

Component Function Check

INFOID:000000009176486

1. CHECK CLIMATE CONTROLLED SEATBACK BLOWER MOTOR FUNCTION

When turning the climate controlled seat switch to the HEAT or COOL mode position, check that the climate controlled seatback blower is operated in each specific mode.

Is the inspection result normal?

- YES >> Inspection End.
 NO >> Refer to [SE-64, "Diagnosis Procedure"](#).

Diagnosis Procedure

INFOID:000000009176487

Regarding Wiring Diagram information, refer to [SE-37, "Wiring Diagram"](#).

1. CHECK CLIMATE CONTROLLED SEAT BLOWER MOTOR POWER SUPPLY

1. Turn ignition switch ON.
2. Check voltage between climate controlled seat blower motor harness connector and ground.

(+)		(-)	Condition	Voltage (V) (Approx.)		
Climate controlled seat blower motor Connector	Terminal					
Driver side	B213	2	Ground	Climate controlled seat switch	HEAT mode	12
					COOL mode	
					Other than above	
Passenger side	B307			Climate controlled seat switch	HEAT mode	12
					COOL mode	
					Other than above	

Is the inspection result normal?

- YES >> GO TO 3.
 NO >> GO TO 2.

2. CHECK CLIMATE CONTROLLED SEAT BLOWER MOTOR POWER SUPPLY CIRCUIT

1. Turn ignition switch OFF.
2. Disconnect climate controlled seat blower motor connector and climate controlled seat control unit connector.
3. Check continuity between climate controlled seat blower motor harness connector and climate controlled seat control unit harness connector.

Climate controlled seat blower motor		Climate controlled seat control unit		Continuity
Connector	Terminal	Connector	Terminal	
Driver side	B213	B203	7	Yes
Passenger side	B307	B303		

4. Check continuity between climate controlled seat blower motor harness connector and ground.

Climate controlled seat blower motor		Ground	Continuity
Connector	Terminal		
Driver side	B213	2	No
Passenger side	B307		

Is the inspection result normal?

CLIMATE CONTROLLED SEAT BLOWER MOTOR

< DTC/CIRCUIT DIAGNOSIS >

- YES >> Replace climate controlled seat control unit. Refer to [SE-86, "Removal and Installation"](#).
 NO >> Repair or replace harness.

3. CHECK CLIMATE CONTROLLED SEAT BLOWER MOTOR SPEED CONTROL SIGNAL

Check voltage between climate controlled seat blower motor harness connector and ground.

(+)		Terminal	(-)	Condition	Voltage (V) (Approx.)		
Climate controlled seat blower motor							
Connector							
Driver side	B213	3	Ground	Climate controlled seat switch	HEAT	5.5 - 8	
				Climate controlled seat switch	COOL	HI	11.2
						MID	8
						LO	6.5
Other than above		0					
Passenger side	B307	3	Ground	Climate controlled seat switch	HEAT	5.5 - 8	
				Climate controlled seat switch	COOL	HI	11.2
						MID	8
						LO	6.5
Other than above		0					

Is the inspection result normal?

- YES >> GO TO 5.
 NO >> GO TO 4.

4. CHECK CLIMATE CONTROLLED SEAT BLOWER MOTOR SPEED CONTROL SIGNAL CIRCUIT

- Turn ignition switch OFF.
- Disconnect climate controlled seat blower motor connector and climate controlled seat control unit connector.
- Check continuity between climate controlled seat blower motor harness connector and climate controlled seat control unit harness connector.

Climate controlled seat blower motor		Climate controlled seat control unit		Continuity
Connector	Terminal	Connector	Terminal	
Driver side	B213	B203	4	Yes
Passenger side	B307	B303		

4. Check continuity between climate controlled seatback blower motor harness connector and ground.

Climate controlled seat blower motor		Ground	Continuity
Connector	Terminal		
Driver side	B213	3	No
Passenger side	B307		

Is the inspection result normal?

- YES >> Replace climate controlled seat control unit. Refer to [SE-86, "Removal and Installation"](#).
 NO >> Repair or replace harness.

5. CHECK CLIMATE CONTROLLED SEAT BLOWER MOTOR GROUND CIRCUIT

- Turn ignition switch OFF.
- Disconnect climate controlled seat blower motor and climate controlled seat control unit connector.
- Check continuity between climate controlled seat blower motor harness connector and climate controlled seat control unit harness connector.

CLIMATE CONTROLLED SEAT BLOWER MOTOR

< DTC/CIRCUIT DIAGNOSIS >

Climate controlled seat blower motor		Climate controlled seat control unit		Continuity
Connector	Terminal	Connector	Terminal	
Driver side	B213	4	B203	Yes
Passenger side	B307		B303	

4. Check continuity between climate controlled seatback blower motor harness connector and ground.

Climate controlled seat blower motor		Ground	Continuity
Connector	Terminal		
Driver side	B213	4	No
Passenger side	B307		

Is the inspection result normal?

- YES >> Replace climate controlled seat blower motor. Refer to [SE-89, "Blower Motor"](#).
 NO >> Repair or replace harness.

CLIMATE CONTROLLED SEAT SWITCH INDICATOR

< DTC/CIRCUIT DIAGNOSIS >

CLIMATE CONTROLLED SEAT SWITCH INDICATOR

Component Function Check

INFOID:000000009176488

1. CHECK CLIMATE CONTROLLED SEAT SWITCH INDICATOR FUNCTION

Check that the related indicator lamp illuminates when climate controlled seat switch is set to HEAT or COOL mode.

Is the inspection result normal?

- YES >> Inspection End.
- NO >> Refer to [SE-67, "Diagnosis Procedure"](#).

Diagnosis Procedure

INFOID:000000009176489

Regarding Wiring Diagram information, refer to [SE-37, "Wiring Diagram"](#).

1. CHECK CLIMATE CONTROLLED SEAT SWITCH INPUT SIGNAL

1. Turn ignition switch ON.
2. Check voltage between climate controlled seat switch harness connector and ground.

(+)		(-)	Condition		Voltage (V) (Approx.)
Climate controlled seat switch			Climate controlled seat switch		
Connector	Terminal	Ground			
Driver side	M203		5	HEAT mode	12
			4	OFF	0
Passenger side	M206		5	COOL mode	12
			4	OFF	0
				HEAT mode	12
				OFF	0
				COOL mode	12
		OFF		0	

Is the inspection result normal?

- YES >> GO TO 3.
- NO >> GO TO 2.

2. CHECK CLIMATE CONTROLLED SEAT SWITCH INDICATOR CIRCUIT

1. Turn ignition switch OFF.
2. Disconnect climate controlled seat switch connector and climate controlled seat control unit connector.
3. Check continuity between climate controlled seat switch harness connector and climate controlled seat control unit harness connector.

Climate controlled seat switch		Climate controlled seat control unit		Continuity
Connector	Terminal	Connector	Terminal	
Driver side	M203	B203	4	9
			5	1
Passenger side	M206	B303	4	9
			5	1

4. Check continuity between climate controlled seat switch harness connector and ground.

CLIMATE CONTROLLED SEAT SWITCH INDICATOR

< DTC/CIRCUIT DIAGNOSIS >

Climate controlled seat switch			Ground	Continuity
Connector		Terminal		No
Driver side	M203	4 5		
Passenger side	M206	4 5		

Is the inspection result normal?

YES >> Replace climate controlled seat control unit. Refer to [SE-86, "Removal and Installation"](#).

NO >> Repair or replace harness.

3. CHECK CLIMATE CONTROLLED SEAT SWITCH GROUND CIRCUIT

1. Turn ignition switch OFF.
2. Disconnect climate controlled seat switch connector.
3. Check continuity between climate controlled seat switch harness connector and ground.

Climate controlled seat switch			Ground	Continuity
Connector		Terminal		Yes
Driver side	M203	6		
Passenger side	M206			

Is the inspection result normal?

YES >> Replace climate controlled seat switch. Refer to [IP-18, "Removal and Installation"](#).

NO >> Repair or replace harness.

CLIMATE CONTROLLED SEAT BLOWER FILTER

< DTC/CIRCUIT DIAGNOSIS >

CLIMATE CONTROLLED SEAT BLOWER FILTER

Diagnosis Procedure

INFOID:000000009176490

1. CHECK CLIMATE CONTROLLED SEAT BLOWER FILTER

Remove climate controlled seat blower filter and check that there is no clogging by dirt or foreign matters.

Is the inspection result normal?

YES >> Inspection End.

NO >> Replace climate controlled seat blower filter. Refer to [SE-89, "Blower Motor Filter"](#).

A
B
C
D
E
F
G
H
I
K
L
M
N
O
P

SE

CLIMATE CONTROLLED SEAT SYSTEM

< SYMPTOM DIAGNOSIS >

SYMPTOM DIAGNOSIS

CLIMATE CONTROLLED SEAT SYSTEM

Symptom Table

INFOID:000000009176494

Symptom		Inspection item
Climate controlled seat inoperative.		Power supply and ground circuit Refer to SE-49, "CLIMATE CONTROLLED SEAT CONTROL UNIT : Diagnosis Procedure" .
Climate controlled seat blower motor inoperative.		Climate controlled seat blower motor Refer to SE-64, "Diagnosis Procedure" .
Seat cushion thermal electric device inoperative.		Seat cushion thermal electric device Refer to SE-60, "Diagnosis Procedure" .
Seatback thermal electric device inoperative.		Seatback thermal electric device Refer to SE-56, "Diagnosis Procedure" .
Climate controlled seat switch LO, MED or HI inoperative.		Climate controlled seat switch Refer to SE-53, "Diagnosis Procedure" .
Climate controlled seat switch indicator inoperative.		Climate controlled seat switch indicator Refer to SE-67, "Diagnosis Procedure" .
Climate controlled seat turns off too soon.	Climate controlled seat switch indicator turns off within 10 seconds of turning on.	Malfunction caused by electrical issue. Check the following: <ul style="list-style-type: none"> • Connectors for physical damage or loose terminals. • Seat cushion thermal electric device. Refer to SE-60, "Diagnosis Procedure". • Seatback thermal electric device. Refer to SE-56, "Diagnosis Procedure". • Climate controlled seat blower motor. Refer to SE-64, "Diagnosis Procedure".
	Climate controlled seat switch indicator turns off 30 seconds or more after turning on.	Malfunction caused by mechanical issue. Check the following: <ul style="list-style-type: none"> • Foam seat pads not aligned for thermal electric device outlet. • Thermal electric device ducting restricted or disconnected. • Climate controlled seat blower motor inlet restricted.

SQUEAK AND RATTLE TROUBLE DIAGNOSES

< SYMPTOM DIAGNOSIS >

SQUEAK AND RATTLE TROUBLE DIAGNOSES

Work Flow

INFOID:00000009763633

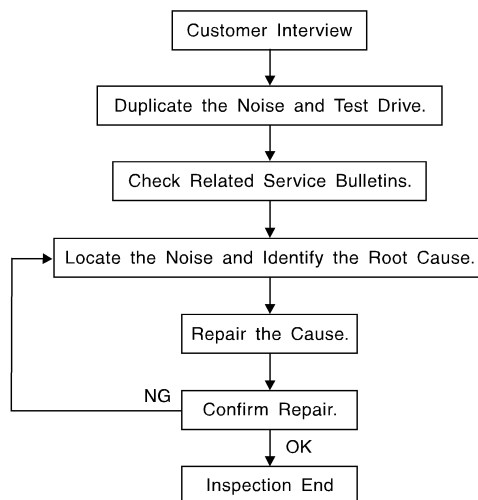

SBT842

CUSTOMER INTERVIEW

Interview the customer if possible, to determine the conditions that exist when the noise occurs. Use the Diagnostic Worksheet during the interview to document the facts and conditions when the noise occurs and any customer's comments; refer to [SE-75, "Diagnostic Worksheet"](#). This information is necessary to duplicate the conditions that exist when the noise occurs.

- The customer may not be able to provide a detailed description or the location of the noise. Attempt to obtain all the facts and conditions that exist when the noise occurs (or does not occur).
- If there is more than one noise in the vehicle, be sure to diagnose and repair the noise that the customer is concerned about. This can be accomplished by test driving the vehicle with the customer.
- After identifying the type of noise, isolate the noise in terms of its characteristics. The noise characteristics are provided so the customer, service adviser and technician are all speaking the same language when defining the noise.
- Squeak —(Like tennis shoes on a clean floor)
Squeak characteristics include the light contact/fast movement/brought on by road conditions/hard surfaces = higher pitch noise/softer surfaces = lower pitch noises/edge to surface = chirping.
- Creak—(Like walking on an old wooden floor)
Creak characteristics include firm contact/slow movement/twisting with a rotational movement/pitch dependent on materials/often brought on by activity.
- Rattle—(Like shaking a baby rattle)
Rattle characteristics include the fast repeated contact/vibration or similar movement/loose parts/missing clip or fastener/incorrect clearance.
- Knock —(Like a knock on a door)
Knock characteristics include hollow sounding/sometimes repeating/often brought on by driver action.
- Tick—(Like a clock second hand)
Tick characteristics include gentle contacting of light materials/loose components/can be caused by driver action or road conditions.
- Thump—(Heavy, muffled knock noise)
Thump characteristics include softer knock/dead sound often brought on by activity.
- Buzz—(Like a bumble bee)
Buzz characteristics include high frequency rattle/firm contact.
- Often the degree of acceptable noise level will vary depending upon the person. A noise that you may judge as acceptable may be very irritating to the customer.
- Weather conditions, especially humidity and temperature, may have a great effect on noise level.

DUPLICATE THE NOISE AND TEST DRIVE

If possible, drive the vehicle with the customer until the noise is duplicated. Note any additional information on the Diagnostic Worksheet regarding the conditions or location of the noise. This information can be used to duplicate the same conditions when you confirm the repair.

SQUEAK AND RATTLE TROUBLE DIAGNOSES

< SYMPTOM DIAGNOSIS >

If the noise can be duplicated easily during the test drive, to help identify the source of the noise, try to duplicate the noise with the vehicle stopped by doing one or all of the following:

- 1) Close a door.
 - 2) Tap or push/pull around the area where the noise appears to be coming from.
 - 3) Rev the engine.
 - 4) Use a floor jack to recreate vehicle "twist".
 - 5) At idle, apply engine load (electrical load, half-clutch on M/T model, drive position on CVT and A/T models).
 - 6) Raise the vehicle on a hoist and hit a tire with a rubber hammer.
- Drive the vehicle and attempt to duplicate the conditions the customer states exist when the noise occurs.
 - If it is difficult to duplicate the noise, drive the vehicle slowly on an undulating or rough road to stress the vehicle body.

CHECK RELATED SERVICE BULLETINS

After verifying the customer concern or symptom, check ASIST for Technical Service Bulletins (TSBs) related to that concern or symptom.

If a TSB relates to the symptom, follow the procedure to repair the noise.

LOCATE THE NOISE AND IDENTIFY THE ROOT CAUSE

1. Narrow down the noise to a general area. To help pinpoint the source of the noise, use a listening tool (Chassis Ear: J-39570, Engine Ear: J-39565 and mechanic's stethoscope).
2. Narrow down the noise to a more specific area and identify the cause of the noise by:
 - removing the components in the area that you suspect the noise is coming from.
Do not use too much force when removing clips and fasteners, otherwise clips and fasteners can be broken or lost during the repair, resulting in the creation of new noise.
 - tapping or pushing/pulling the component that you suspect is causing the noise.
Do not tap or push/pull the component with excessive force, otherwise the noise will be eliminated only temporarily.
 - feeling for a vibration with your hand by touching the component(s) that you suspect is (are) causing the noise.
 - placing a piece of paper between components that you suspect are causing the noise.
 - looking for loose components and contact marks.Refer to [SE-72. "Generic Squeak and Rattle Troubleshooting"](#).

REPAIR THE CAUSE

- If the cause is a loose component, tighten the component securely.
- If the cause is insufficient clearance between components:
 - separate components by repositioning or loosening and retightening the component, if possible.
 - insulate components with a suitable insulator such as urethane pads, foam blocks, felt cloth tape or urethane tape. A NISSAN Squeak and Rattle Kit (J-50397) is available through your authorized NISSAN Parts Department.

CAUTION:

Do not use excessive force as many components are constructed of plastic and may be damaged.

NOTE:

- Always check with the Parts Department for the latest parts information.
- The materials contained in the NISSAN Squeak and Rattle Kit (J-50397) are listed on the inside cover of the kit; and can each be ordered separately as needed.
- The following materials not found in the kit can also be used to repair squeaks and rattles.
 - SILICONE GREASE: Use instead of UHMW tape that will be visible or does not fit. The silicone grease will only last a few months.
 - SILICONE SPRAY: Use when grease cannot be applied.
 - DUCT TAPE: Use to eliminate movement.

CONFIRM THE REPAIR

Confirm that the cause of a noise is repaired by test driving the vehicle. Operate the vehicle under the same conditions as when the noise originally occurred. Refer to the notes on the Diagnostic Worksheet.

Generic Squeak and Rattle Troubleshooting

INFOID:000000009763634

Refer to Table of Contents for specific component removal and installation information.

INSTRUMENT PANEL

Most incidents are caused by contact and movement between:

SQUEAK AND RATTLE TROUBLE DIAGNOSES

< SYMPTOM DIAGNOSIS >

1. Cluster lid A and the instrument panel
2. Acrylic lens and combination meter housing
3. Instrument panel to front pillar finisher
4. Instrument panel to windshield
5. Instrument panel pins
6. Wiring harnesses behind the combination meter
7. A/C defroster duct and duct joint

These incidents can usually be located by tapping or moving the components to duplicate the noise or by pressing on the components while driving to stop the noise. Most of these incidents can be repaired by applying felt cloth tape or silicone spray (in hard to reach areas). Urethane pads can be used to insulate wiring harness.

CAUTION:

Do not use silicone spray to isolate a squeak or rattle. If you saturate the area with silicone, you will not be able to recheck the repair.

CENTER CONSOLE

Components to pay attention to include:

1. Shift selector assembly cover to finisher
2. A/C control unit and cluster lid C
3. Wiring harnesses behind audio and A/C control unit

The instrument panel repair and isolation procedures also apply to the center console.

DOORS

Pay attention to the:

1. Finisher and inner panel making a slapping noise
2. Inside handle escutcheon to door finisher
3. Wiring harnesses tapping
4. Door striker out of alignment causing a popping noise on starts and stops

Tapping or moving the components or pressing on them while driving to duplicate the conditions can isolate many of these incidents. You can usually insulate the areas with felt cloth tape or insulator foam blocks from the NISSAN Squeak and Rattle Kit (J-50397) to repair the noise.

TRUNK

Trunk noises are often caused by a loose jack or loose items put into the trunk by the owner.

In addition look for:

1. Trunk lid bumpers out of adjustment
2. Trunk lid striker out of adjustment
3. The trunk lid torsion bars knocking together
4. A loose license plate or bracket

Most of these incidents can be repaired by adjusting, securing or insulating the item(s) or component(s) causing the noise.

SUNROOF/HEADLINING

Noises in the sunroof/headlining area can often be traced to one of the following:

1. Sunroof lid, rail, linkage or seals making a rattle or light knocking noise
2. Sun visor shaft shaking in the holder
3. Front or rear windshield touching headlining and squeaking

Again, pressing on the components to stop the noise while duplicating the conditions can isolate most of these incidents. Repairs usually consist of insulating with felt cloth tape.

OVERHEAD CONSOLE (FRONT AND REAR)

Overhead console noises are often caused by the console panel clips not being engaged correctly. Most of these incidents are repaired by pushing up on the console at the clip locations until the clips engage.

In addition look for:

1. Loose harness or harness connectors.
2. Front console map/reading lamp lens loose.

A
B
C
D
E
F
G
H
I
SE
K
L
M
N
O
P

SQUEAK AND RATTLE TROUBLE DIAGNOSES

< SYMPTOM DIAGNOSIS >

3. Loose screws at console attachment points.

SEATS

When isolating seat noise it's important to note the position the seat is in and the load placed on the seat when the noise is present. These conditions should be duplicated when verifying and isolating the cause of the noise.

Cause of seat noise include:

1. Headrest rods and holder
2. A squeak between the seat pad cushion and frame
3. The rear seatback lock and bracket

These noises can be isolated by moving or pressing on the suspected components while duplicating the conditions under which the noise occurs. Most of these incidents can be repaired by repositioning the component or applying urethane tape to the contact area.

UNDERHOOD

Some interior noise may be caused by components under the hood or on the engine wall. The noise is then transmitted into the passenger compartment.

Causes of transmitted underhood noise include:

1. Any component installed to the engine wall
2. Components that pass through the engine wall
3. Engine wall mounts and connectors
4. Loose radiator installation pins
5. Hood bumpers out of adjustment
6. Hood striker out of adjustment

These noises can be difficult to isolate since they cannot be reached from the interior of the vehicle. The best method is to secure, move or insulate one component at a time and test drive the vehicle. Also, engine rpm or load can be changed to isolate the noise. Repairs can usually be made by moving, adjusting, securing, or insulating the component causing the noise.

SQUEAK AND RATTLE TROUBLE DIAGNOSES

< SYMPTOM DIAGNOSIS >

Diagnostic Worksheet

INFOID:000000009763635

Dear Customer:

We are concerned about your satisfaction with your vehicle. Repairing a squeak or rattle sometimes can be very difficult. To help us fix your vehicle right the first time, please take a moment to note the area of the vehicle where the squeak or rattle occurs and under what conditions. You may be asked to take a test drive with a service advisor or technician to ensure we confirm the noise you are hearing.

SQUEAK & RATTLE DIAGNOSTIC WORKSHEET

I. WHERE DOES THE NOISE COME FROM? (circle the area of the vehicle)

The illustrations are for reference only, and may not reflect the actual configuration of your vehicle.

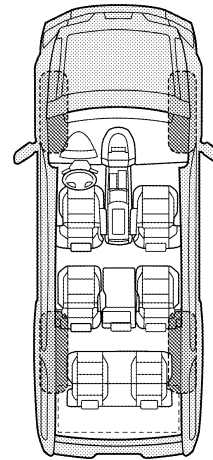
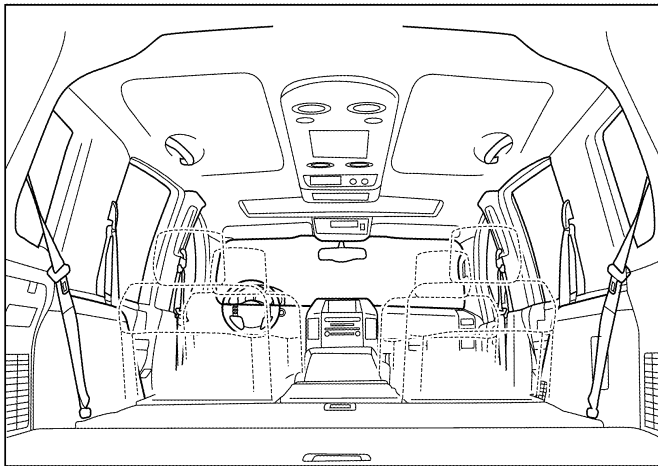
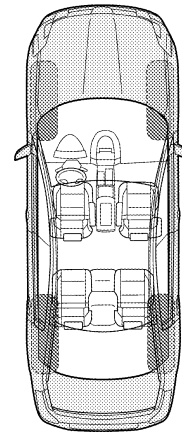
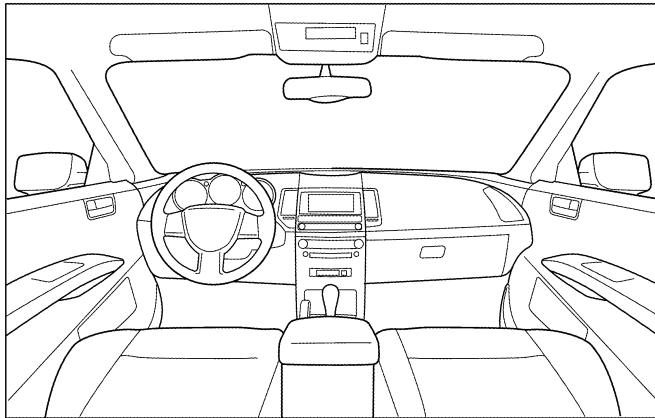

Continue to page 2 of the worksheet and briefly describe the location of the noise or rattle. In addition, please indicate the conditions which are present when the noise occurs.

A
B
C
D
E
F
G
H
I
SE
K
L
M
N
O
P

SQUEAK AND RATTLE TROUBLE DIAGNOSES

< SYMPTOM DIAGNOSIS >

SQUEAK & RATTLE DIAGNOSTIC WORKSHEET - page 2

Briefly describe the location where the noise occurs:

II. WHEN DOES IT OCCUR? (please check the boxes that apply)

- | | |
|---|--|
| <input type="checkbox"/> Anytime | <input type="checkbox"/> After sitting out in the rain |
| <input type="checkbox"/> 1st time in the morning | <input type="checkbox"/> When it is raining or wet |
| <input type="checkbox"/> Only when it is cold outside | <input type="checkbox"/> Dry or dusty conditions |
| <input type="checkbox"/> Only when it is hot outside | <input type="checkbox"/> Other: |

III. WHEN DRIVING:

- Through driveways
- Over rough roads
- Over speed bumps
- Only about ____ mph
- On acceleration
- Coming to a stop
- On turns: left, right or either (circle)
- With passengers or cargo
- Other: _____
- After driving ____ miles or ____ minutes

IV. WHAT TYPE OF NOISE

- Squeak (like tennis shoes on a clean floor)
- Creak (like walking on an old wooden floor)
- Rattle (like shaking a baby rattle)
- Knock (like a knock at the door)
- Tick (like a clock second hand)
- Thump (heavy muffled knock noise)
- Buzz (like a bumble bee)

TO BE COMPLETED BY DEALERSHIP PERSONNEL

Test Drive Notes:

	YES	NO	Initials of person performing
Vehicle test driven with customer	<input type="checkbox"/>	<input type="checkbox"/>	_____
- Noise verified on test drive	<input type="checkbox"/>	<input type="checkbox"/>	_____
- Noise source located and repaired	<input type="checkbox"/>	<input type="checkbox"/>	_____
- Follow up test drive performed to confirm repair	<input type="checkbox"/>	<input type="checkbox"/>	_____

VIN: _____ Customer Name _____
W.O.# _____ Date: _____

This form must be attached to Work Order

LAI0071E

FRONT SEAT

< REMOVAL AND INSTALLATION >

REMOVAL AND INSTALLATION

FRONT SEAT

Exploded View

INFOID:000000009727771

DRIVER SEAT WITH CLIMATE CONTROL

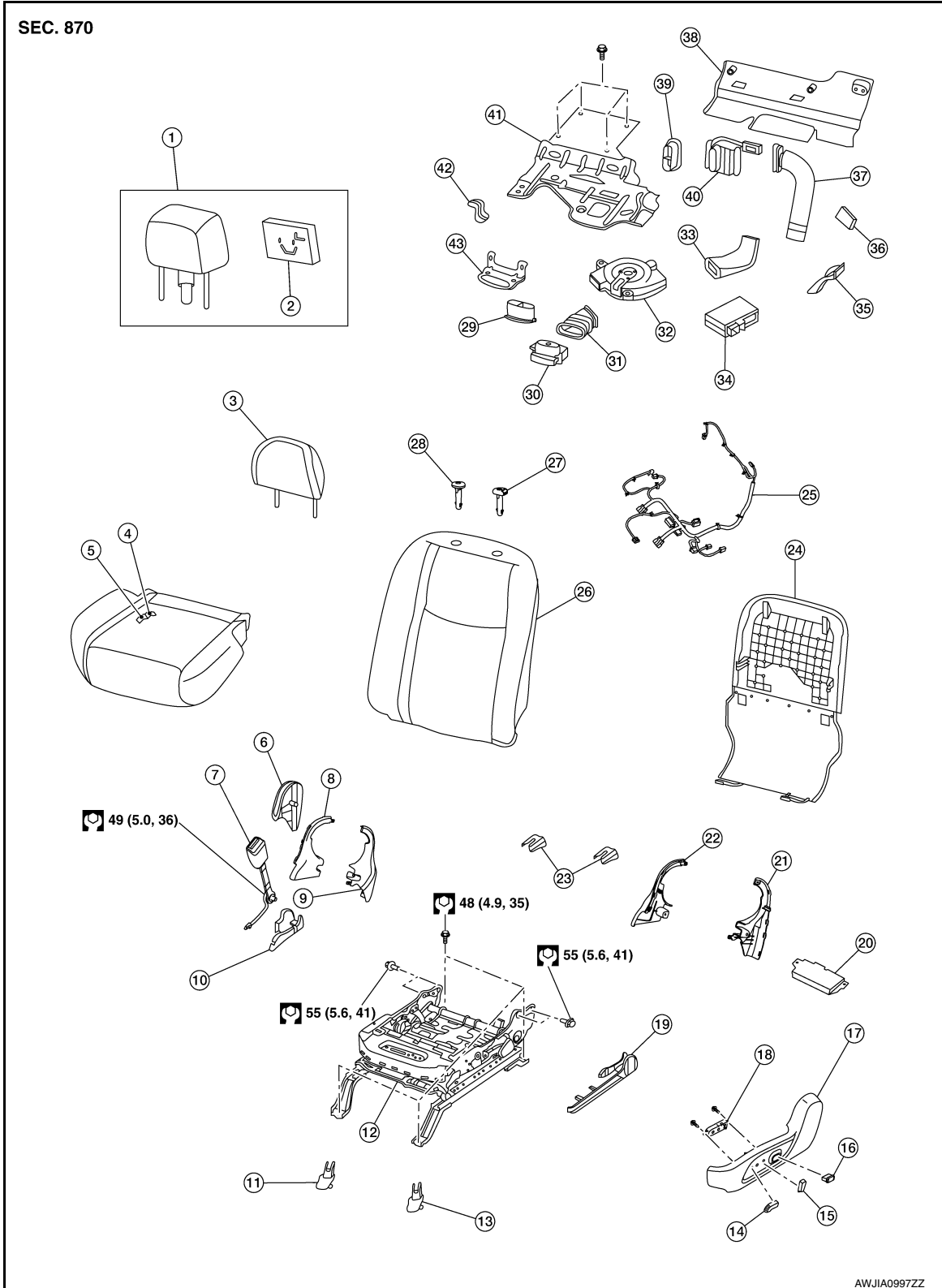

A
B
C
D
E
F
G
H
I
SE
K
L
M
N
O
P

FRONT SEAT

< REMOVAL AND INSTALLATION >

- | | | |
|--|---|---|
| 1. Headrest assembly with display unit | 2. Headrest display unit | 3. Headrest without display unit |
| 4. Seat cushion trim | 5. Seat cushion pad | 6. Seat cushion outer finisher (RH) |
| 7. Seat belt buckle | 8. Seat cushion inner finisher (RH) (front) | 9. Seat cushion inner finisher (RH) (rear) |
| 10. Slide finisher outer (RH) | 11. Front slide finisher (RH) | 12. Seat frame assembly |
| 13. Front slide finisher (LH) | 14. Seat slide knob | 15. Seat recline knob |
| 16. Lumbar support switch | 17. Seat cushion outer finisher (LH) | 18. Power seat switch |
| 19. Slide finisher outer (LH) | 20. Power seat control unit | 21. Seat cushion inner finisher (LH) (rear) |
| 22. Seat cushion inner finisher (LH) (front) | 23. Rear slide finisher | 24. Seatback board |
| 25. Seat harness | 26. Seatback assembly | 27. Headrest holder (locked) |
| 28. Headrest holder (free) | 29. Thermal electric device nozzle | 30. Seat cushion thermal electric device |
| 31. Lower blower duct | 32. Blower motor with filter | 33. Angle duct |
| 34. Climate controlled seat control unit | 35. Thermal electric device clip | 36. Upper blower duct clip |
| 37. Upper blower duct | 38. Lower rear cover | 39. Thermal electric device nozzle |
| 40. Seatback thermal electric device | 41. Blower motor bracket | 42. Thermal electric device harness bracket |
| 43. Thermal electric device bracket | | |

FRONT SEAT

< REMOVAL AND INSTALLATION >

DRIVER SEAT WITHOUT CLIMATE CONTROL

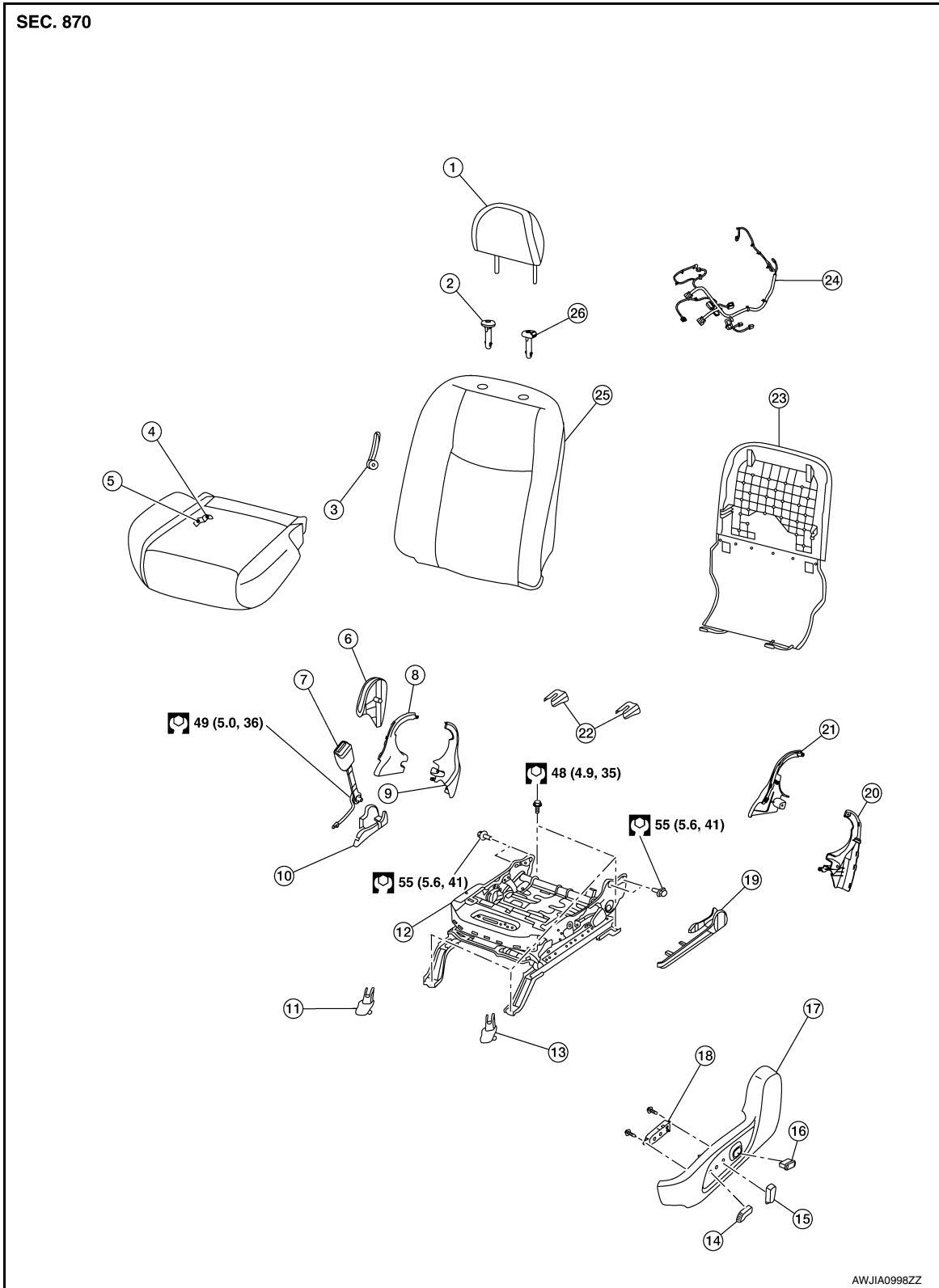

- | | | |
|-------------------------------|---|--|
| 1. Headrest | 2. Headrest holder (free) | 3. Lumbar lever (if equipped) |
| 4. Seat cushion trim | 5. Seat cushion pad | 6. Seat cushion outer finisher (RH) |
| 7. Seat belt buckle | 8. Seat cushion inner finisher (RH) (front) | 9. Seat cushion inner finisher (RH) (rear) |
| 10. Slide finisher outer (RH) | 11. Front slide finisher (RH) | 12. Seat frame assembly |
| 13. Front slide finisher (LH) | 14. Seat slide knob | 15. Seat recline knob |

A
B
C
D
E
F
G
H
I
SE
K
L
M
N
O
P

FRONT SEAT

< REMOVAL AND INSTALLATION >

- | | | |
|---|---|--|
| 16. Lumbar support switch (if equipped) | 17. Seat cushion outer finisher (LH) | 18. Power seat switch |
| 19. Slide finisher outer (LH) | 20. Seat cushion inner finisher (LH) (rear) | 21. Seat cushion inner finisher (LH) (front) |
| 22. Rear slide finisher | 23. Seatback board | 24. Seat harness |
| 25. Seatback assembly | 26. Headrest holder (locked) | |

DRIVER SEAT - MANUAL

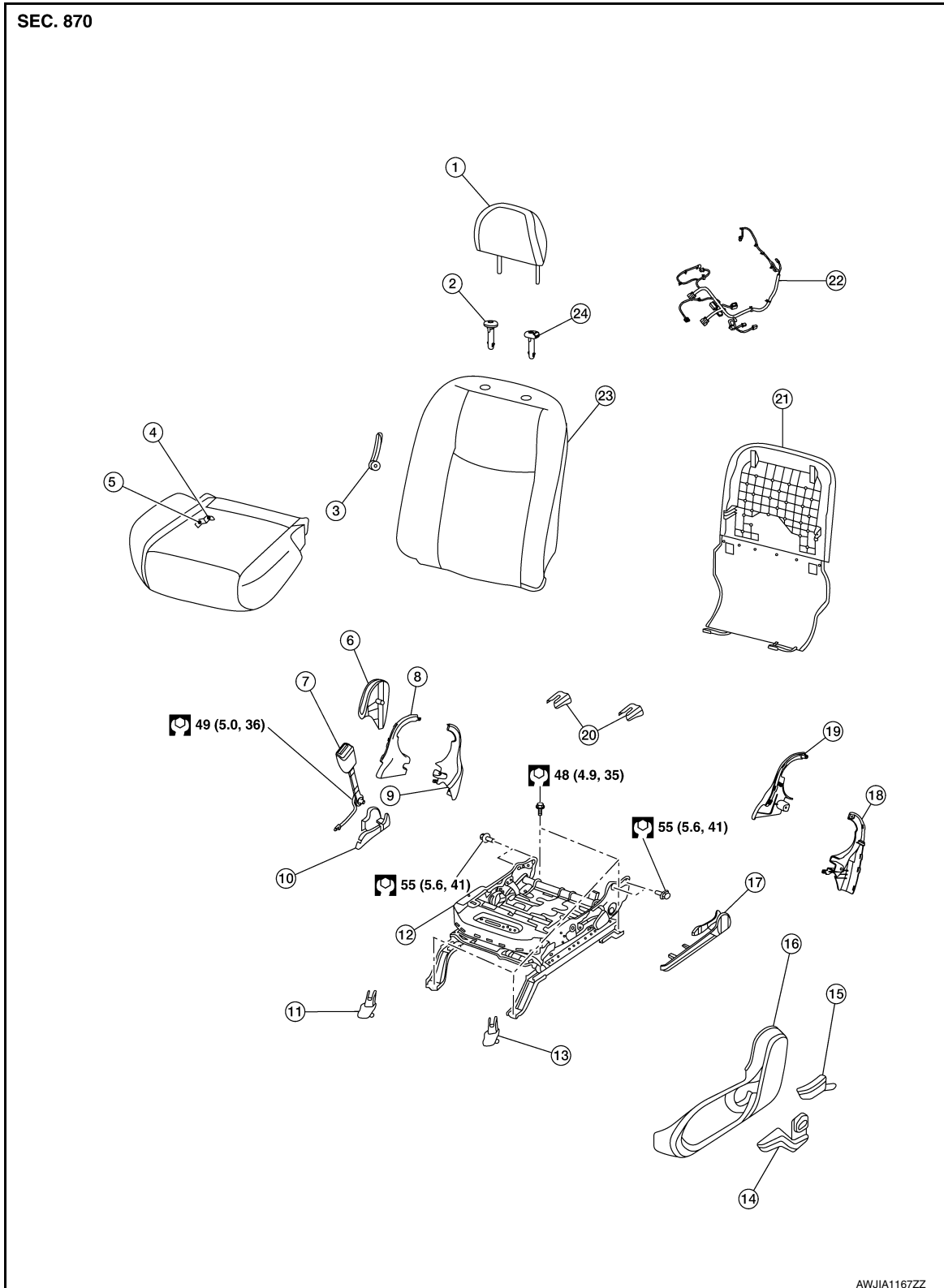

FRONT SEAT

< REMOVAL AND INSTALLATION >

1. Headrest	2. Headrest holder (free)	3. Lumbar lever	A
4. Seat cushion trim	5. Seat cushion pad	6. Seat cushion outer finisher (RH)	
7. Seat belt buckle	8. Seat cushion inner finisher (RH) (front)	9. Seat cushion inner finisher (RH) (rear)	B
10. Slide finisher outer (RH)	11. Front slide finisher (RH)	12. Seat frame assembly	
13. Front slide finisher (LH)	14. Lift lever	15. Recline lever finisher	
16. Seat cushion outer finisher (LH)	17. Slide finisher outer (LH)	18. Seat cushion inner finisher (LH) (rear)	C
19. Seat cushion inner finisher (LH) (front)	20. Rear slide finisher	21. Seatback board	
22. Seat harness	23. Seatback assembly	24. Headrest holder (locked)	D

E

F

G

H

I

SE

K

L

M

N

O

P

FRONT SEAT

< REMOVAL AND INSTALLATION >

PASSENGER SEAT WITH CLIMATE CONTROL

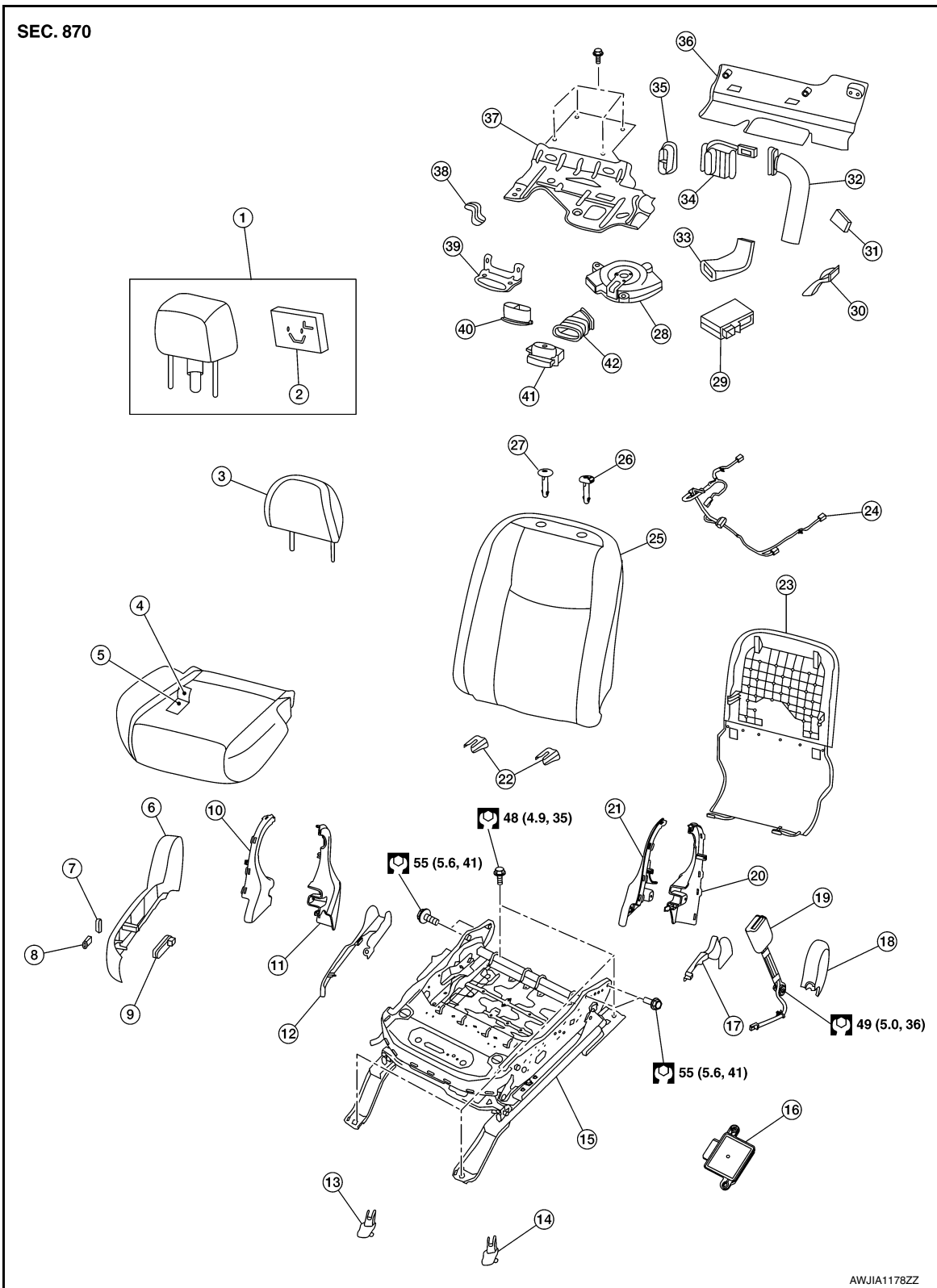

- | | | |
|--|---|-------------------------------------|
| 1. Headrest assembly with display unit | 2. Headrest display unit | 3. Headrest without display unit |
| 4. Seat cushion trim | 5. Seat cushion pad | 6. Seat cushion outer finisher (RH) |
| 7. Seat recline knob | 8. Seat slide knob | 9. Power seat switch |
| 10. Seat cushion inner finisher (RH) (front) | 11. Seat cushion inner finisher (RH) (rear) | 12. Slide finisher outer (RH) |
| 13. Front slide finisher (RH) | 14. Front slide finisher (LH) | 15. Seat frame assembly |

FRONT SEAT

< REMOVAL AND INSTALLATION >

16. Occupant Classification System control unit (except Mexico)	17. Slide finisher outer (LH)	18. Seat cushion outer finisher (LH)	A
19. Seat belt buckle	20. Seat cushion inner finisher (LH) (rear)	21. Seat cushion inner finisher (LH) (front)	B
22. Rear slide finisher	23. Seatback board	24. Seat harness	B
25. Seatback assembly	26. Headrest holder (locked)	27. Headrest holder (free)	C
28. Blower motor with filter	29. Climate controlled seat control unit	30. Thermal electric device clip	C
31. Upper blower duct clip	32. Upper blower duct	33. Angle duct	C
34. Seatback thermal electric device	35. Thermal electric device nozzle	36. Lower rear cover	D
37. Thermal electric device bracket	38. Thermal electric device harness bracket	39. Blower motor bracket	D
40. Thermal electric device nozzle	41. Seat cushion thermal electric device	42. Lower blower duct	D

SE

FRONT SEAT

< REMOVAL AND INSTALLATION >

PASSENGER SEAT WITHOUT CLIMATE CONTROL

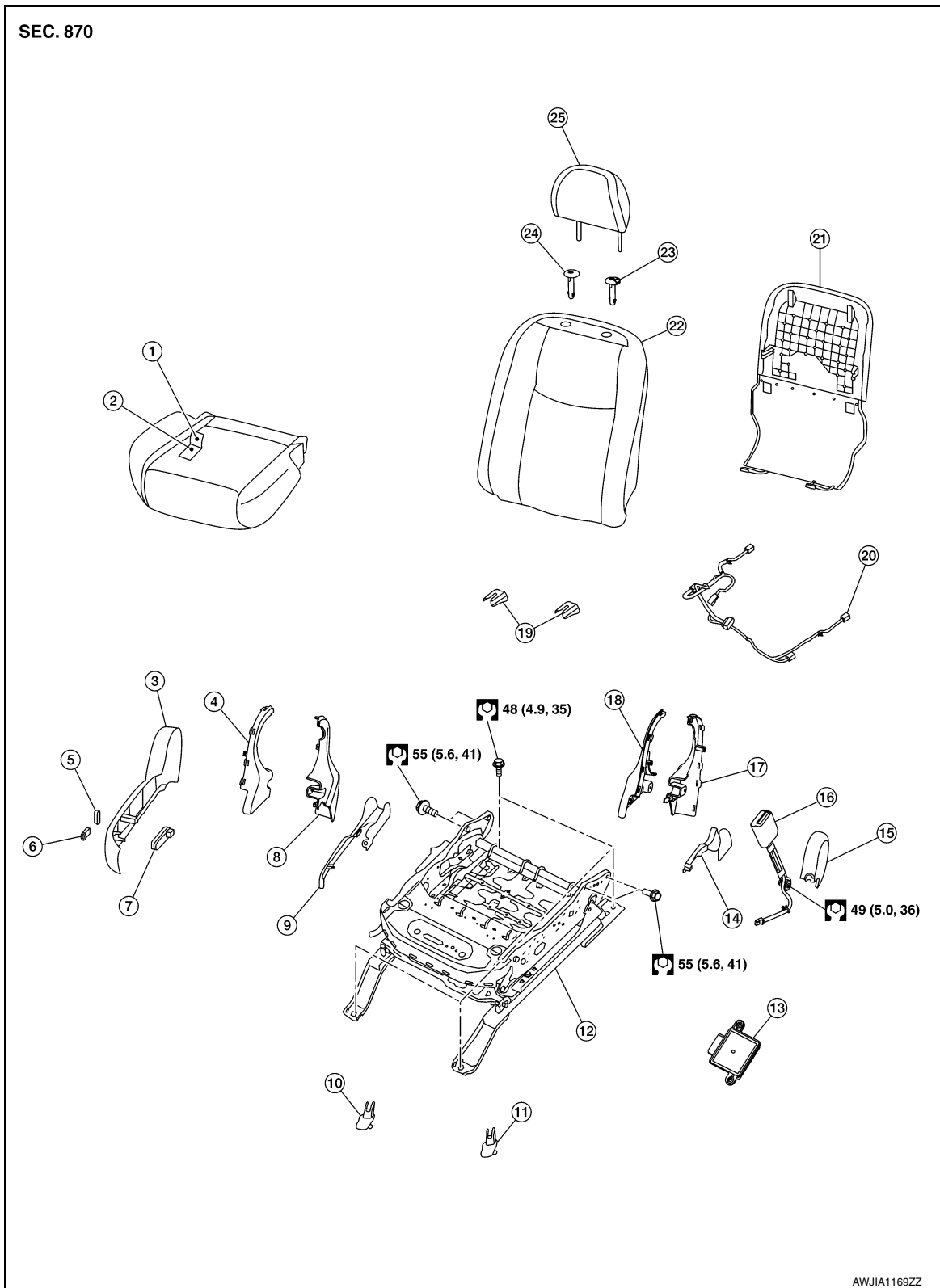

- | | | |
|---|--|-------------------------------------|
| 1. Seat cushion trim | 2. Seat cushion pad | 3. Seat cushion outer finisher (RH) |
| 4. Seat cushion inner finisher (RH) (front) | 5. Seat recline knob | 6. Seat slide knob |
| 7. Power seat switch | 8. Seat cushion inner finisher (RH) (rear) | 9. Slide finisher outer (RH) |
| 10. Front slide finisher (RH) | 11. Front slide finisher (LH) | 12. Seat frame assembly |

FRONT SEAT

< REMOVAL AND INSTALLATION >

- | | | |
|---|---|--|
| 13. Occupant Classification System control unit (except Mexico) | 14. Slide finisher outer (LH) | 15. Seat cushion outer finisher (LH) |
| 16. Seat belt buckle | 17. Seat cushion inner finisher (LH) (rear) | 18. Seat cushion inner finisher (LH) (front) |
| 19. Rear slide finisher | 20. Seat harness | 21. Seatback board |
| 22. Seatback assembly | 23. Headrest holder (locked) | 24. Headrest holder (free) |
| 25. Headrest | | |

PASSENGER SEAT - MANUAL

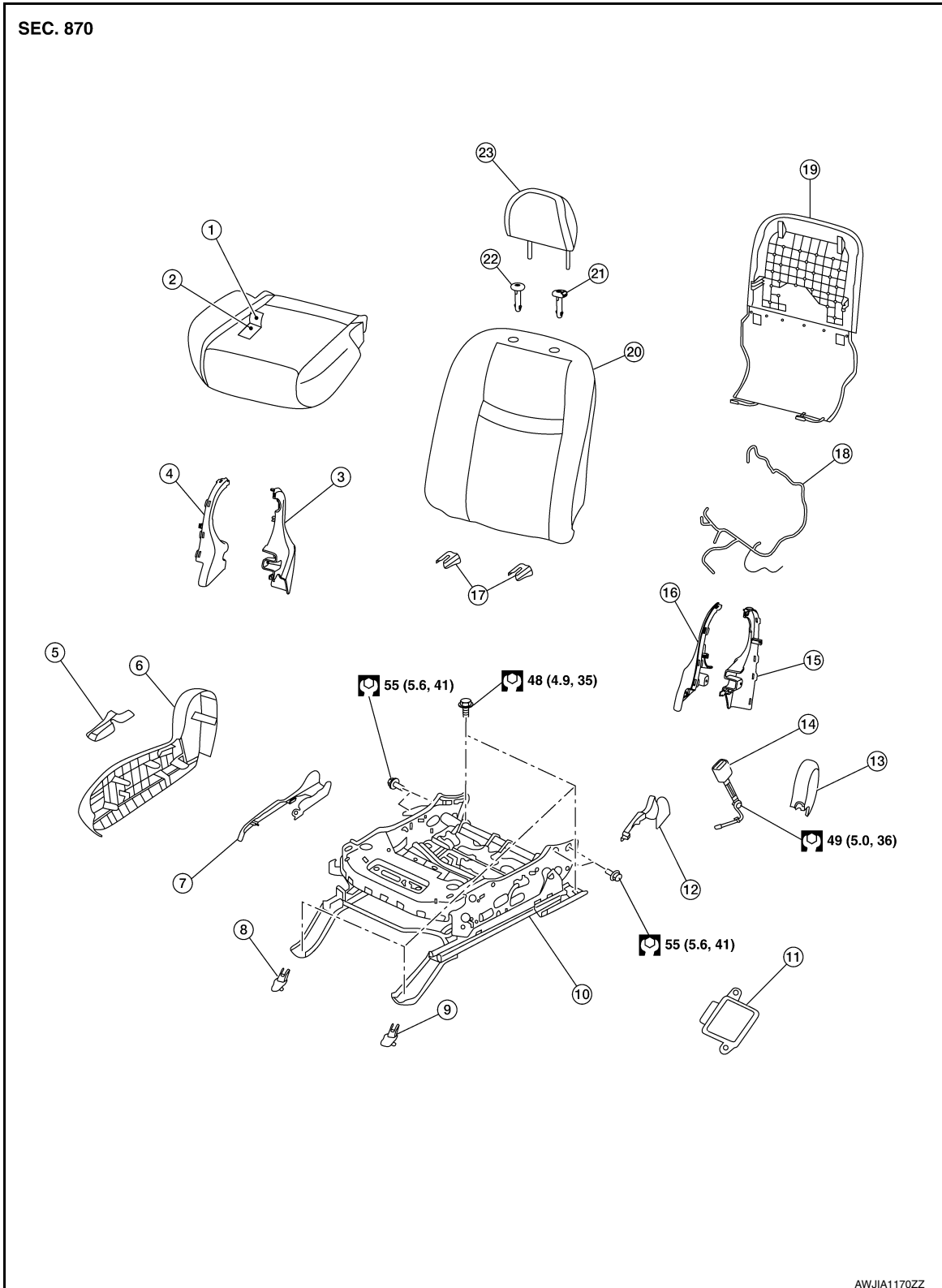

A
B
C
D
E
F
G
H
I
SE
K
L
M
N
O
P

FRONT SEAT

< REMOVAL AND INSTALLATION >

- | | | |
|--|---|---|
| 1. Seat cushion trim | 2. Seat cushion pad | 3. Seat cushion inner finisher (RH) (rear) |
| 4. Seat cushion inner finisher (RH) (front) | 5. Recline lever finisher | 6. Seat cushion outer finisher (RH) |
| 7. Slide finisher outer (RH) | 8. Front slide finisher (RH) | 9. Front slide finisher (LH) |
| 10. Seat frame assembly | 11. Occupant Classification System control unit (except Mexico) | 12. Slide finisher outer (LH) |
| 13. Seat cushion outer finisher (LH) | 14. Seat belt buckle | 15. Seat cushion inner finisher (LH) (rear) |
| 16. Seat cushion inner finisher (LH) (front) | 17. Rear slide finisher | 18. Seat harness |
| 19. Seatback board | 20. Seatback assembly | 21. Headrest holder (locked) |
| 22. Headrest holder (free) | 23. Headrest | |

Removal and Installation

INFOID:000000009727772

REMOVAL

WARNING:

Do not leave any objects (screwdrivers, tools, etc.) on the seat during seatback repair. It can lead to personal injury if the side air bag module should accidentally deploy.

CAUTION:

- When removing or installing the seat trim, handle it carefully to keep dirt out and to avoid damage.
- When checking the power seat circuit for continuity using a circuit tester, do not confuse its connector with the side air bag module connector. Such an error may cause the air bag module to deploy.
- Do not drop, tilt, or bump the side air bag module while installing the seat. Always handle it with care.
- After front side air bag module inflates, the front seatback assembly must be replaced.
- When removing and installing the seat, use shop cloths to protect components from damage.
- Before removing the front seat, turn the ignition switch OFF, disconnect both battery cables then wait at least three minutes.

1. Slide the seat to the full rearward position.
2. Disconnect negative and positive battery terminals, then wait at least three minutes. Refer to [PG-90, "Removal and Installation"](#).
3. Disconnect the harness connector for side air bag module.
4. Remove the front slide finishers (LH/RH) (A) by lifting up and then pulling forward, then remove the seat front bolts.
5. Connect the negative and positive battery terminals, then slide the seat to the full forward position. Refer to [PG-90, "Removal and Installation"](#).
6. Disconnect negative and positive battery terminals, then wait at least three minutes. Refer to [PG-90, "Removal and Installation"](#).
7. Remove the rear slide finishers (LH/RH) (B) by lifting up and then pulling rearward, then remove the seat rear bolts.

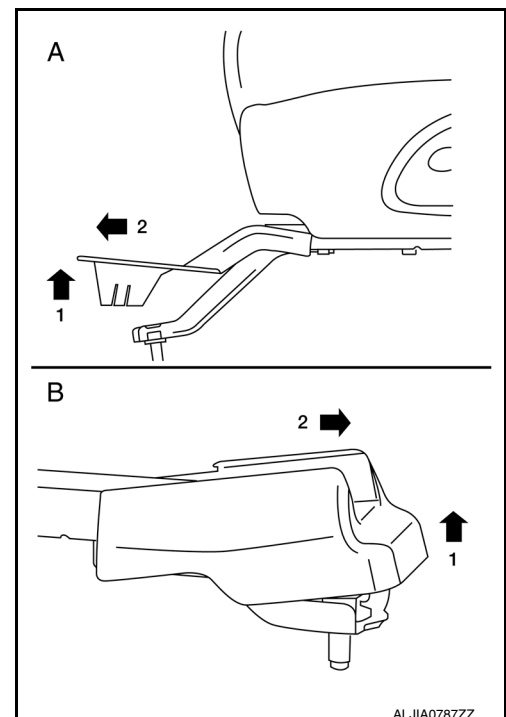

FRONT SEAT

< REMOVAL AND INSTALLATION >

8. Tilt the seat rearward and disconnect the harness connectors from the seat.

NOTE:

Take note of harness routing and attachment locations for correct installation.

9. Remove the seat from the vehicle.

INSTALLATION

Installation is in the reverse order of removal.

WARNING:

- Perform additional services when installing front passenger seat (except Mexico). Refer to [SRC-41, "ADDITIONAL SERVICE WHEN REPLACING CONTROL UNIT : Description"](#).
- Zero point reset must be performed every time the front passenger seat is removed from the vehicle.
- Zero point reset is done after the front passenger seat is installed in vehicle and all bolts are tightened to specification.

CAUTION:

Make sure that the seat harness or the floor carpet is not damaged during installation.

NOTE:

- When installing the front seat (LH), tighten the bolts in the order shown.
- Tighten the seat bolts to specification. Refer to [SE-77, "Exploded View"](#).

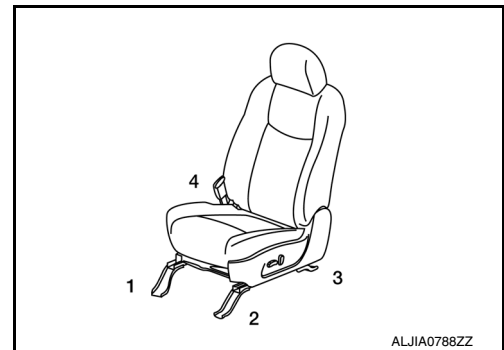

- When installing the front seat (RH), tighten the bolts in the order shown.
- Tighten the seat bolts to specification. Refer to [SE-77, "Exploded View"](#).

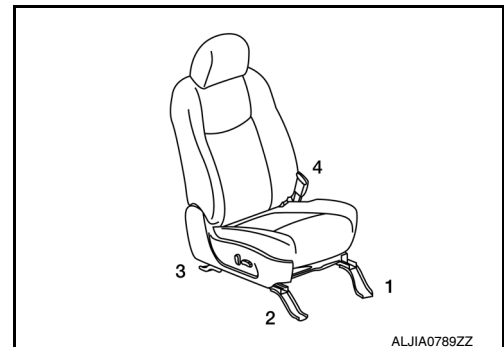

Seatback Board

INFOID:000000009727773

REMOVAL

WARNING:

Do not leave any objects (screwdrivers, tools, etc.) on the seat during seatback repair. It can lead to personal injury if the side air bag module should accidentally deploy.

CAUTION:

- When removing or installing the seat trim, handle it carefully to keep dirt out and to avoid damage.
 - Before removing the front seat, turn the ignition switch OFF, disconnect both battery cables then wait at least three minutes.
1. Disconnect negative and positive battery terminals, then wait at least three minutes. Refer to [PG-90, "Removal and Installation"](#).

FRONT SEAT

< REMOVAL AND INSTALLATION >

2. Release the two J-hook retainers (A) from the seatback frame.
3. Release the seatback board lower clips (B).
CAUTION:
Do not reuse seatback board lower clips.
4. Reach behind the seatback board and press the center clips (C) inward and release from the seatback frame.
5. Pull the seatback board down releasing the upper clips (D) and remove.

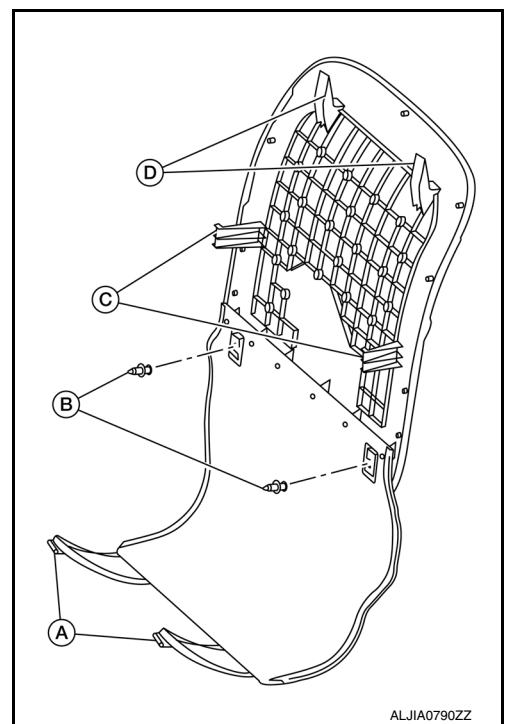

INSTALLATION

Installation is in the reverse order of removal.

Seatback Thermal Electric Device

INFOID:000000009727774

REMOVAL

1. Remove the seatback board. Refer to [SE-87, "Seatback Board"](#).
2. Release the seatback hook fastener straps (A).
3. Release the seatback J-clip retainers (B) holding the seatback trim to the seatback frame.
4. Disconnect the harness connector (1) from the seatback thermal electric device (2).
5. Remove the tie straps and seatback thermal electric device (2) from the upper blower duct and seatback frame.

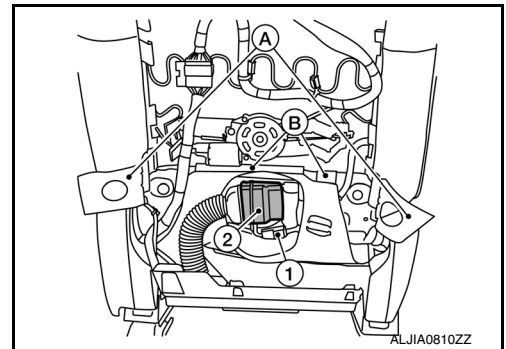

INSTALLATION

Installation is in the reverse order of removal.

NOTE:

Do not reuse tie straps, new tie straps must be used for installation.

Seat Cushion Thermal Electric Device

INFOID:000000009727775

REMOVAL

1. Remove the front seat. Refer to [SE-86, "Removal and Installation"](#).

FRONT SEAT

< REMOVAL AND INSTALLATION >

2. Remove the tie strap and lower blower duct (3) from the seat cushion thermal electric device (2).
⇐: Front
3. Disconnect the harness connector (1) from the seat cushion thermal electric device (2).
4. Release the retaining clip and remove the seat cushion thermal electric device (2) from the seat frame assembly.

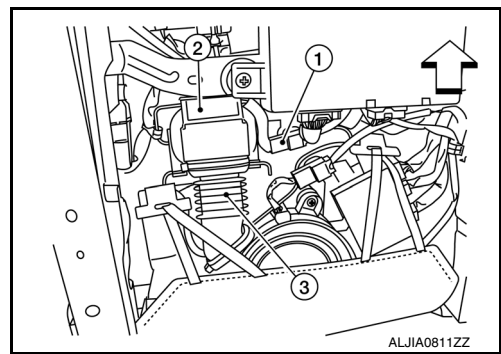

INSTALLATION

Installation is in the reverse order of removal.

NOTE:

Do not reuse tie straps, new tie straps must be used for installation.

Blower Motor Filter

INFOID:000000009727776

REMOVAL

1. Remove the front seat. Refer to [SE-86, "Removal and Installation"](#).
2. Release the J-hook retainers (A) from the seat frame assembly.
3. Remove the four screws and the seat cushion lower rear cover (1) from the seat frame assembly.

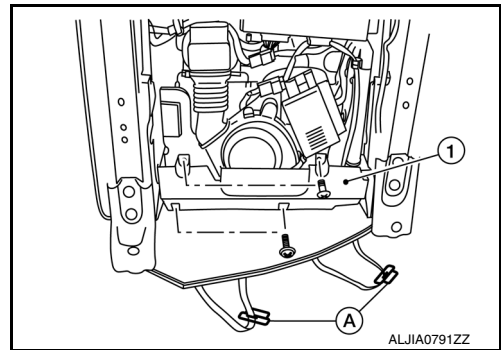

4. Rotate the climate controlled blower motor filter (1) counter clockwise and remove it from the blower motor (2).

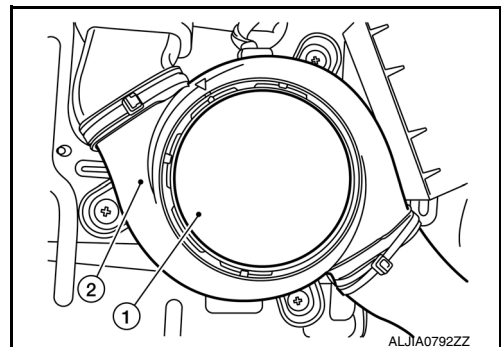

Blower Motor

INFOID:000000009727777

REMOVAL

1. Remove the front seat. Refer to [SE-86, "Removal and Installation"](#).

FRONT SEAT

< REMOVAL AND INSTALLATION >

2. Release the J-hook retainers (A) from the seat frame assembly.
3. Remove the four screws and the seat cushion lower rear cover (1) from the seat frame assembly.

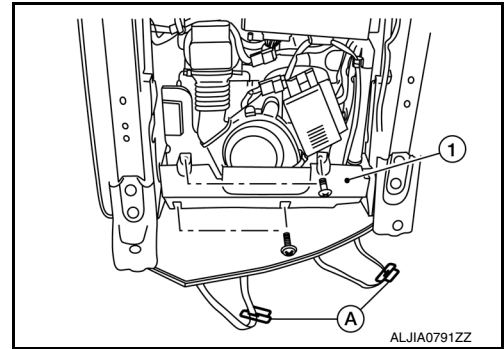

4. Disconnect the harness connector (A) from the blower motor.
⇐: Front
5. Remove the tie straps and discard, then remove the angle duct (B) and lower blower duct (C) from the blower motor.
6. Remove the screws (D) and the blower motor.

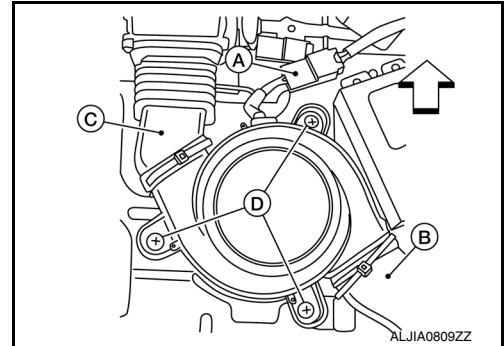

INSTALLATION

Installation is in the reverse order of removal.

NOTE:

Do not reuse tie straps, new tie straps must be used for installation.

SECOND ROW SEATS

< REMOVAL AND INSTALLATION >

SECOND ROW SEATS

Exploded View

INFOID:00000009727778

LH SEAT

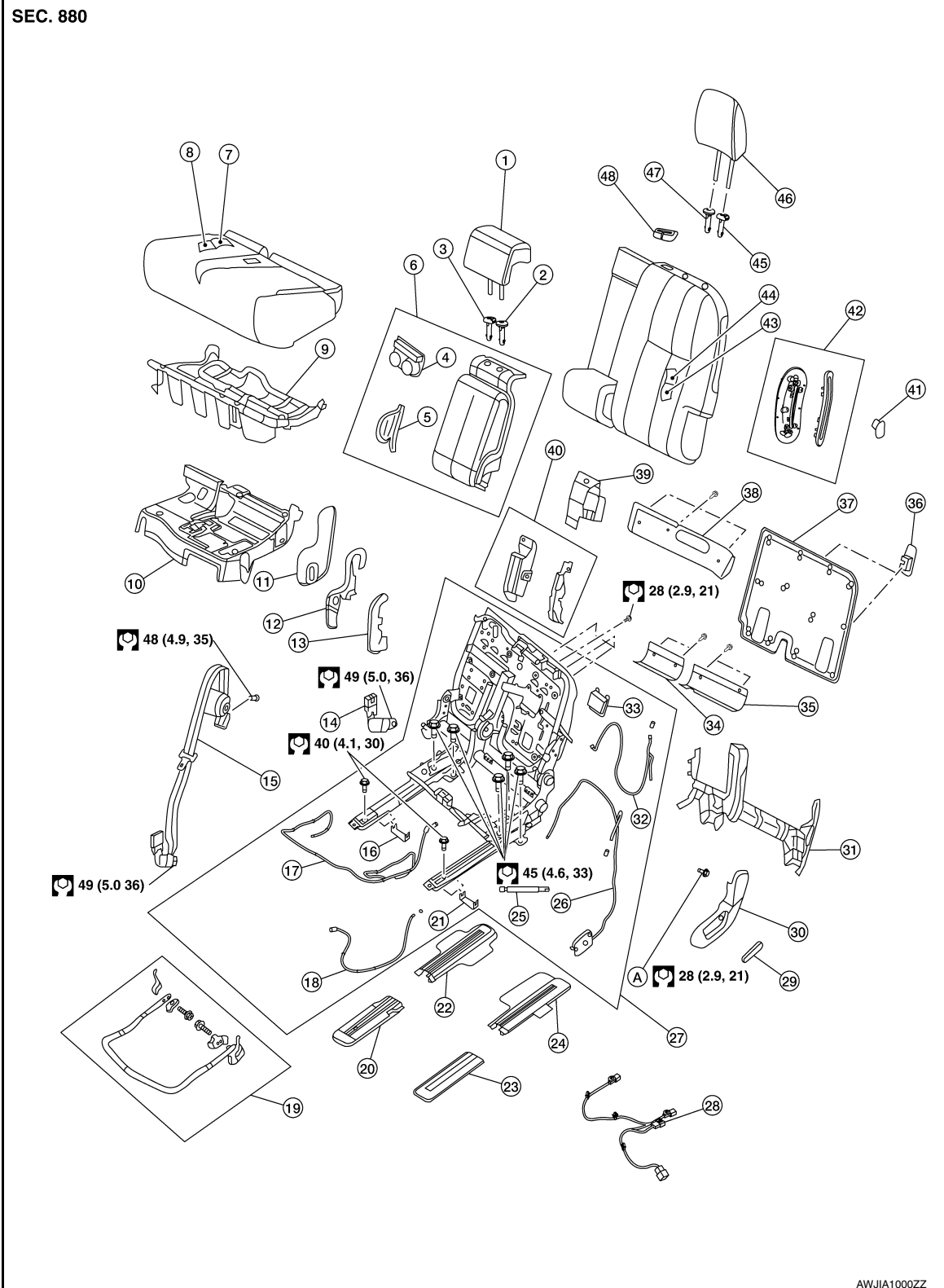

- | | | |
|------------------|--------------------------------|----------------------------------|
| 1. Headrest (RH) | 2. Headrest holder (free) (RH) | 3. Headrest holder (locked) (RH) |
| 4. Cup holder | 5. Armrest hinge finisher | 6. Armrest assembly |

A
B
C
D
E
F
G
H
I
SE
K
L
M
N
O
P

SECOND ROW SEATS

< REMOVAL AND INSTALLATION >

- | | | |
|---------------------------------------|------------------------------------|------------------------------------|
| 7. Seat cushion trim | 8. Seat cushion pad | 9. Seat cushion frame |
| 10. Seat cushion latch finisher | 11. Outer finisher (RH) | 12. Inner finisher (RH) |
| 13. Recline finisher (center) | 14. Seat belt buckle (RH) | 15. Seat belt retractor (center) |
| 16. Seat slide clip (RH) | 17. Seat slide release cable | 18. Seat cushion release cable |
| 19. Seat slide control lever assembly | 20. Front slide finisher (RH) | 21. Seat slide clip (LH) |
| 22. Rear slide finisher (RH) | 23. Front slide finisher (LH) | 24. Rear slide finisher (LH) |
| 25. Support strut | 26. Recline release cable assembly | 27. Seat frame assembly |
| 28. Seat harness | 29. Recline lever | 30. Seat cushion outer finisher LH |
| 31. Rear finisher | 32. EZ entry cable | 33. Dampener |
| 34. Trim stiffener (RH) | 35. Trim stiffener (LH) | 36. Tether anchor finisher |
| 37. Seatback board | 38. EPP upper panel | 39. Seat belt retractor finisher |
| 40. Support finisher (RH) | 41. EZ entry lever finisher | 42. EZ entry finisher |
| 43. Seatback pad | 44. Seatback trim | 45. Headrest holder (locked) (LH) |
| 46. Headrest (LH) | 47. Headrest holder (free) (LH) | 48. Seat belt retractor finisher |
| A. Seat cushion pivot bolt | | |

SECOND ROW SEATS

< REMOVAL AND INSTALLATION >

RH SEAT

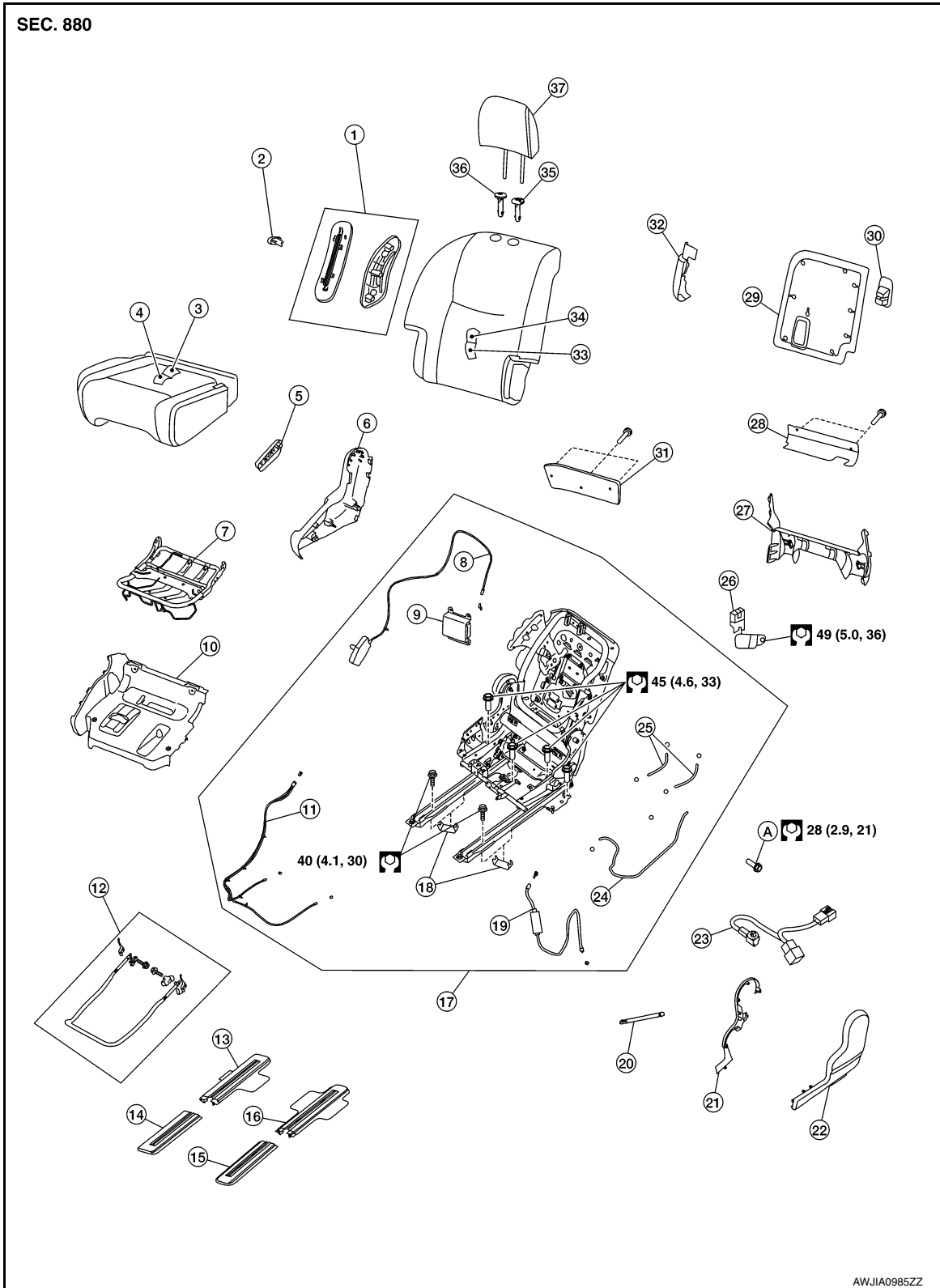

- | | | |
|---------------------------------|-----------------------------------|---------------------------------------|
| 1. EZ entry finisher | 2. EZ entry lever finisher | 3. Seat cushion trim |
| 4. Seat cushion pad | 5. Recline lever | 6. Seat cushion outer finisher (RH) |
| 7. Seat cushion frame | 8. Recline release cable assembly | 9. Dampener |
| 10. Seat cushion latch finisher | 11. Track tilt release cable | 12. Seat slide control lever assembly |
| 13. Rear slide finisher (RH) | 14. Front slide finisher (RH) | 15. Front slide finisher (LH) |
| 16. Rear slide finisher (LH) | 17. Seat frame assembly | 18. Seat slide clip |

SECOND ROW SEATS

< REMOVAL AND INSTALLATION >

- | | | |
|------------------------------|------------------------------|--------------------------------|
| 19. EZ entry cable | 20. Support strut | 21. Inner finisher (LH) |
| 22. Outer finisher (LH) | 23. Seat harness | 24. Seat cushion release cable |
| 25. Seat slide release cable | 26. Seat belt buckle | 27. Rear finisher |
| 28. Trim stiffener | 29. Seatback board | 30. Tether anchor finisher |
| 31. EPP upper panel | 32. Support finisher | 33. Seatback pad |
| 34. Seatback trim | 35. Headrest holder (locked) | 36. Headrest holder (free) |
| 37. Headrest | A. Seat cushion pivot bolt | |

Removal and Installation

INFOID:000000009727779

LH SEAT

Removal

CAUTION:

- Before removal and installation, use shop cloths to protect parts from damage.
- During removal and installation, an assistant is required to protect against injury or damage.

1. Remove the rear kicking plate (LH). Refer to [INT-22. "KICKING PLATE : Removal and Installation - Rear Kicking Plate"](#).
2. Remove the headrests (LH/RH).
3. Slide the seat to the full rearward position.
4. Remove the front slide finishers (LH/RH).
 - a. Pull up on the front edge to release pawls.
 - b. Then slide forward to remove from seat track.
5. Place the front cross brace (1) from Seat Fixture Kit [SST: — (J-51030)] over the track alignment holes, then insert the two LH threaded bolts (A) through the brace into the track and tighten.
⇐: Front

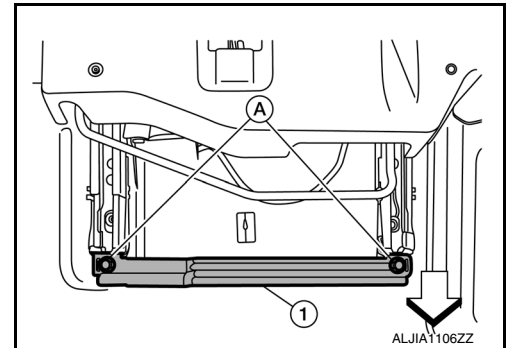

6. Disconnect the harness connector (if equipped), then release from seat frame assembly.
7. Remove the seat front bolts.
8. Slide the seat to the full forward position.
9. Remove the rear slide finishers (LH/RH).
 - a. Pull up on the rear edge to release pawls.
 - b. Then slide forward to remove from seat track.
10. Place the rear cross brace (1) from Seat Fixture Kit [SST: — (J-51030)] over the track alignment holes, then insert the four LH threaded bolts (A) through the brace into the track and tighten.
⇐: Front

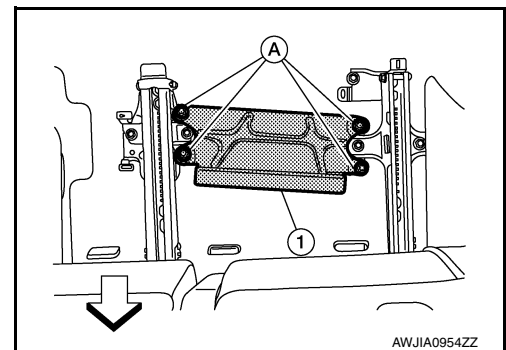

11. Remove the seat rear bolts.
12. Fold the seatback in the flat position, then remove the seat from the vehicle.

SECOND ROW SEATS

< REMOVAL AND INSTALLATION >

Installation

Installation is in the reverse order of removal.

NOTE:

- When installing the LH seat, tighten the bolts in the order shown.
(↔): Front
- Tighten the seat bolts to specification. Refer to [SE-91, "Exploded View"](#).

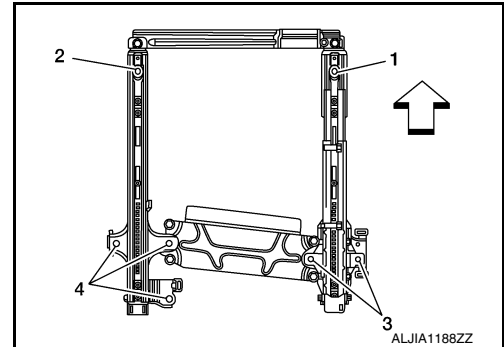

RH SEAT

Removal

CAUTION:

- Before removal and installation, use shop cloths to protect parts from damage.
 - During removal and installation, an assistant is required to protect against injury or damage.
1. Remove the rear kicking plate (RH). Refer to [INT-22, "KICKING PLATE : Removal and Installation - Rear Kicking Plate"](#).
 2. Remove the headrest.
 3. Slide the seat to the full rearward position.
 4. Remove the front slide finishers (LH/RH).
 - a. Pull up on the front edge to release pawls.
 - b. Then slide forward to remove from seat track.
 5. Place the front cross brace (1) from Seat Fixture Kit [SST: — (J-51030)] over the track alignment holes, then insert the two LH threaded bolts (A) through the brace into the track and tighten.
(↔): Front

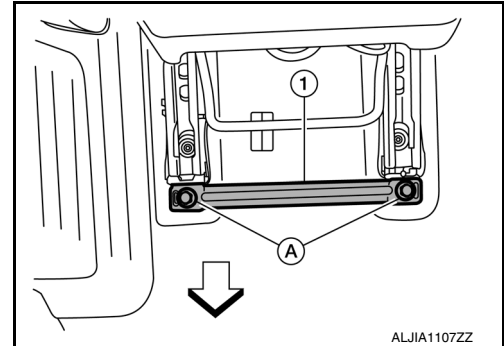

6. Disconnect the harness connector (if equipped), then release from seat frame assembly.
7. Remove the seat front bolts.
8. Slide the seat to the full forward position.
9. Remove the rear slide finishers (LH/RH).
 - a. Pull up on the rear edge to release pawls.
 - b. Then slide forward to remove from seat track.
10. Place the rear cross brace (1) from Seat Fixture Kit [SST: — (J-51030)] over the track alignment holes, then insert the four LH threaded bolts (A) through the brace into the track and tighten.
(↔): Front

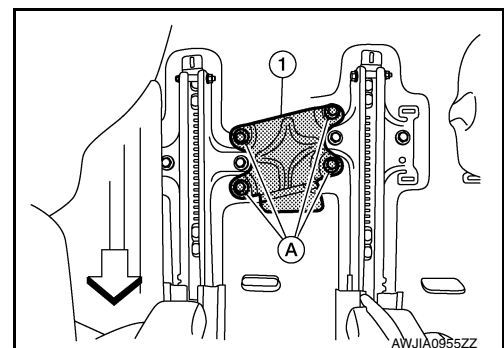

SECOND ROW SEATS

< REMOVAL AND INSTALLATION >

11. Remove the seat rear bolts.
12. Fold the seatback in the flat position, then remove the seat from the vehicle.

Installation

Installation is in the reverse order of removal.

NOTE:

- When installing the RH seat, tighten the bolts in the order shown.
(↔): Front
- Tighten the seat bolts to specification. Refer to [SE-91, "Exploded View"](#).

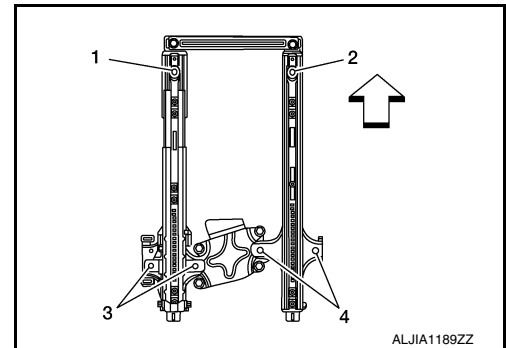

Armrest Assembly

INFOID:000000009727780

REMOVAL

1. Press in the headrest holder button (A), then remove LH seat headrest (RH) (1).

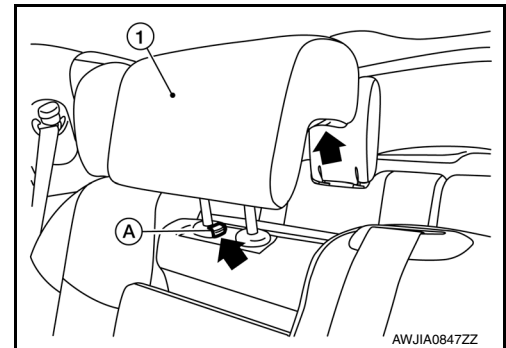

2. Remove the tether anchor finishers (2).
3. Remove seatback board (1).

- △: Clip
- : Pawl

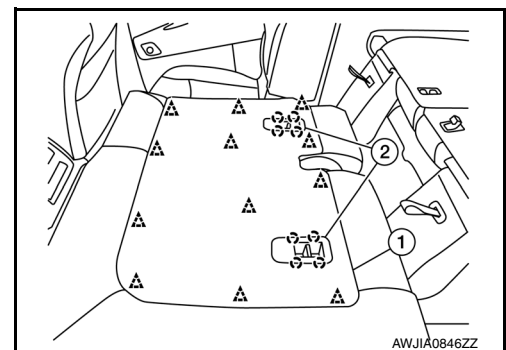

4. Remove four armrest assembly bolts (A) and pull the armrest assembly (1) forward (↔) to release clips.

- : Metal clip
- ↔: Front

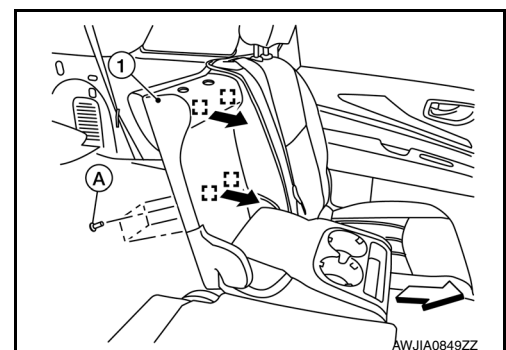

SECOND ROW SEATS

< REMOVAL AND INSTALLATION >

5. Reach up behind the armrest assembly, release the headrest holder locks as shown and remove the headrest holders.

CAUTION:

Before removing/installing headrest holder, check its orientation (front/rear and right/left).

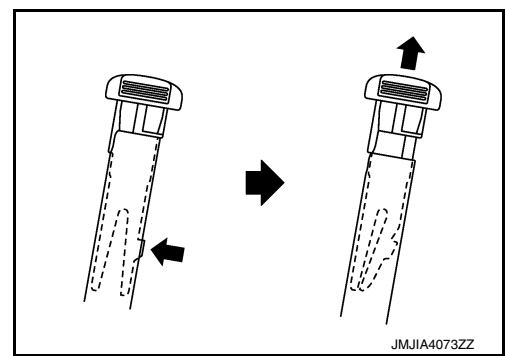

6. Remove the armrest assembly.

INSTALLATION

Installation is in the reverse order of removal.

Seat Cushion

INFOID:000000009727781

LH SEAT

Removal

1. Remove the recline lever.
 - a. Remove snap ring (2) upward using a suitable tool.
 - b. Remove recline lever (1).
2. Remove screw (←) and seat cushion outer finisher (LH) (3).

○ Pawl

□ Metal clip

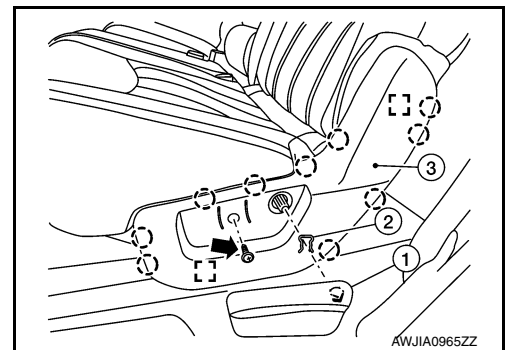

3. Pull seat belt buckles through bottom of LH seat cushion.
4. Disconnect the harness connectors from the LH seat cushion heater (if equipped) and release the harness from attachments.

NOTE:

Take note of harness routing and attachment location for correct installation.

5. Remove the support strut at bottom.
6. Remove seat cushion pivot bolt (←), then the LH seat cushion (1).

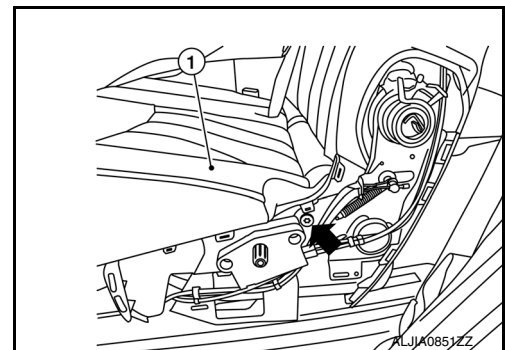

Installation

Installation is in the reverse order of removal.

RH SEAT

Removal

A
B
C
D
E
F
G
H
I
SE
K
L
M
N
O
P

SECOND ROW SEATS

< REMOVAL AND INSTALLATION >

1. Slide the LH seat to the full forward position and slide the RH seat to the full rearward position.
2. Remove outer finisher (LH) (1).

- : Pawl
- △: Clip

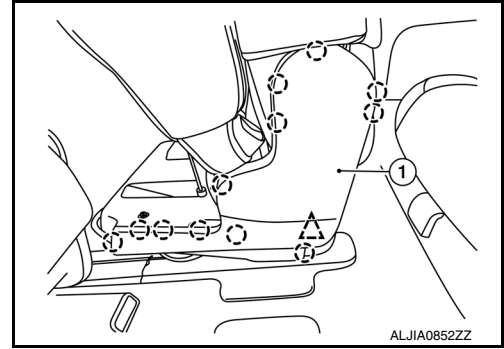

3. Pull seat belt buckle through bottom of RH seat cushion.
4. Disconnect the harness connectors from the RH seat cushion heater (if equipped) and release the harness from attachments.

NOTE:

Take note of harness routing and attachment location for correct installation.

5. Remove the support strut at bottom.
6. Remove seat cushion pivot bolt (←), then the RH seat cushion (1).

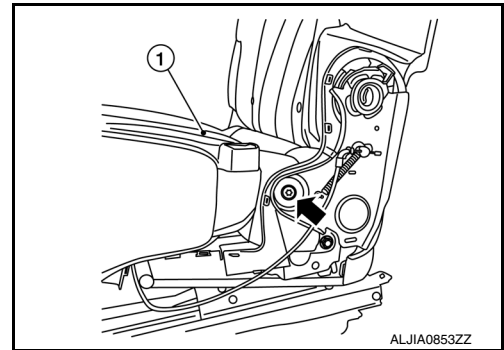

Installation

Installation is in the reverse order of removal.

Seat Cushion Release Cable

INFOID:000000009727782

LH SEAT

Removal

1. Remove the LH seat cushion. Refer to [SE-97. "Seat Cushion"](#).
2. Release pawls and remove the recline finisher (center) (1).

- : Pawl

3. Release clip.

- △: Clip

4. Remove screws (←) and lift seat cushion latch finisher (2) to remove.

- : Metal clip

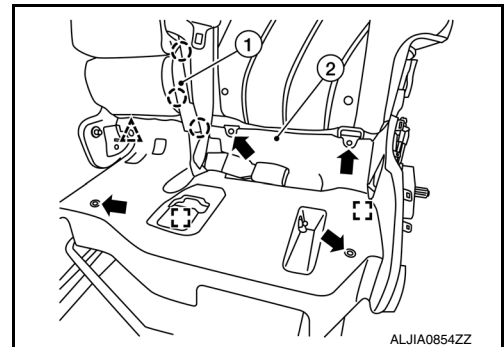

SECOND ROW SEATS

< REMOVAL AND INSTALLATION >

5. Remove the seat cushion release cable (1) from seat cushion latch (2).
6. Release (←) the seat cushion release cable (1) from the seat frame assembly (3).
CAUTION:
Note the cable routing for correct installation,
7. Release cable end (A) and remove seat cushion release cable.

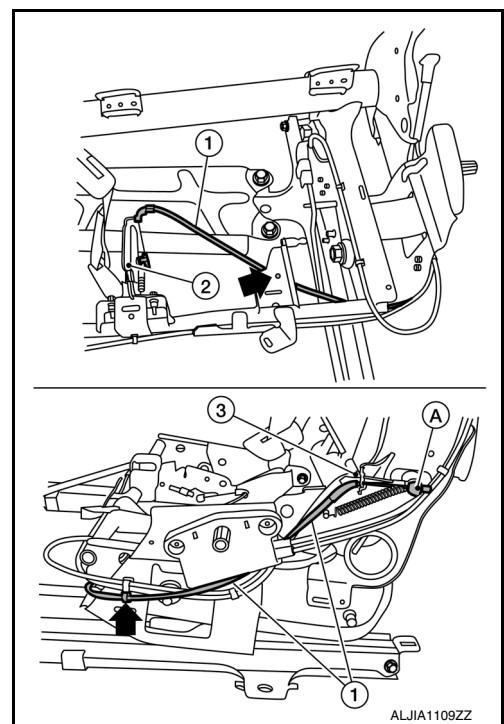

Installation

Installation is in reverse order of removal.

CAUTION:
Route cables correctly for proper function.

RH SEAT

Removal

1. Remove RH seat cushion. Refer to [SE-97. "Seat Cushion"](#).
2. Remove the recline lever.
 - a. Remove snap ring (2) upward using a suitable tool.
 - b. Remove recline lever (3).
3. Remove screw (←) and the seat cushion outer finisher (RH) (1).

○: Pawl

□: Metal clip

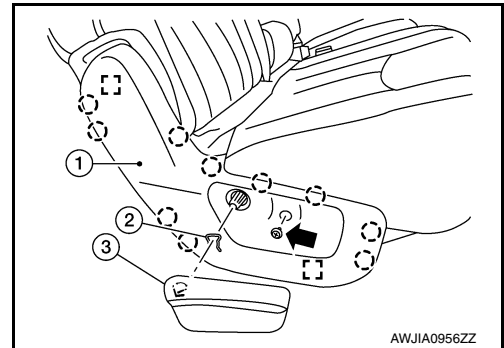

4. Remove screws (←) and lift seat cushion latch finisher (1) to remove.

□: Metal clip

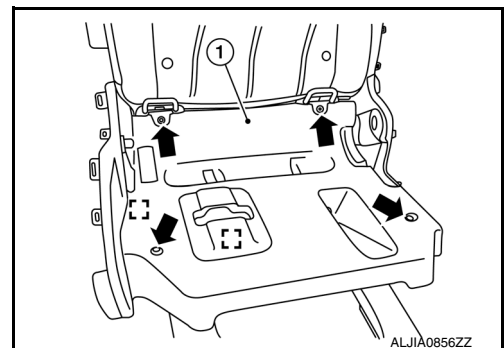

A
B
C
D
E
F
G
H
I
K
L
M
N
O
P

SE

SECOND ROW SEATS

< REMOVAL AND INSTALLATION >

5. Release (←) the seat cushion release cable (1) from the seat frame assembly (3).

CAUTION:

Note the cable routing for correct installation.

- a. Remove the seat cushion release cable (1) from the seat cushion latch (2).
- b. Separate the cushion release cable (1) from the seat frame assembly (3).
- c. Release cable end (A) and remove seat cushion release cable (1).

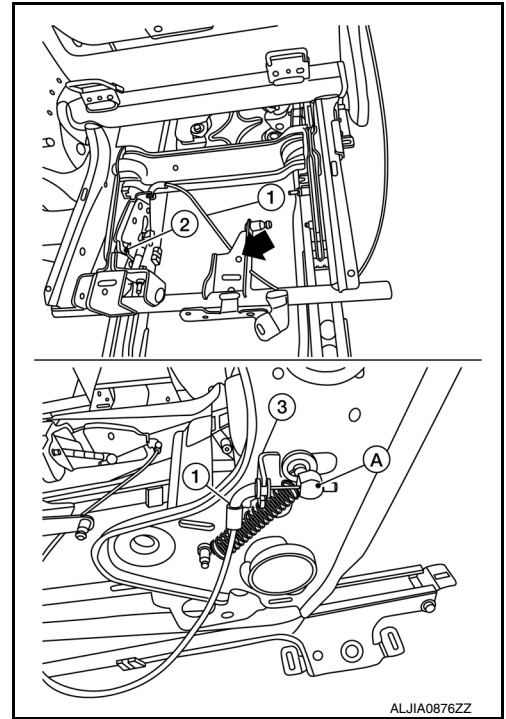

Installation

Installation is in reverse order of removal.

CAUTION:

Route cables correctly for proper function.

Seat Slide Release Cable

INFOID:000000009727783

LH SEAT

Removal

1. Remove LH seat cushion. Refer to [SE-97. "Seat Cushion"](#).
2. Release pawls and remove the recline finisher (center) (1).
○: Pawl
3. Release clip.
△: Clip
4. Remove screws (←) and lift the seat cushion latch finisher (2) to remove.
□: Metal clip

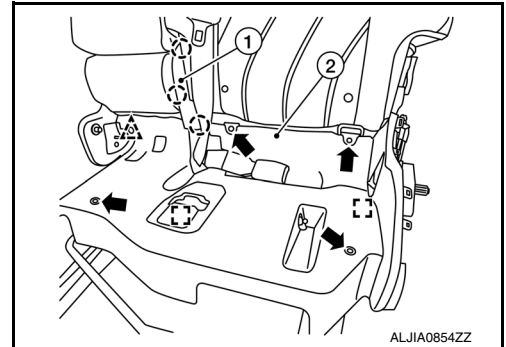

SECOND ROW SEATS

< REMOVAL AND INSTALLATION >

5. Remove the seat slide release cable (1) from both RH side (A) and LH side (B) of seat frame assembly.
 - a. Release (←) the seat slide release cable (1) from the seat frame assembly.

CAUTION:

Note the cable routing for correct installation.

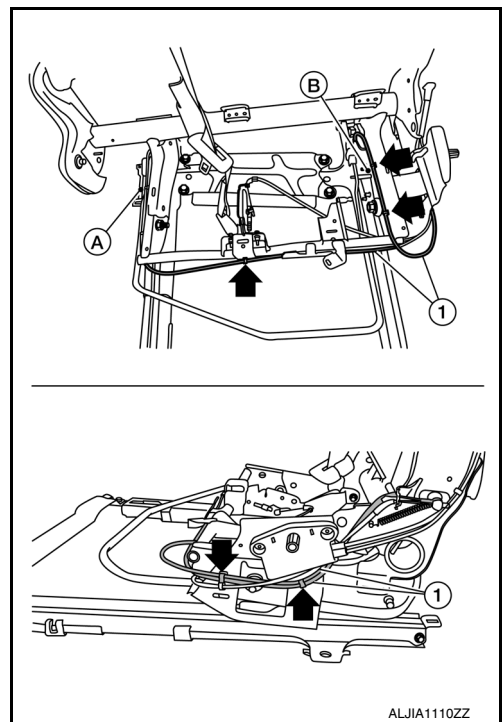

- b. Release (←) the seat slide release cable (1).
 - c. Separate the seat slide release cable (1) from the seat frame assembly (2).
 - d. Release cable end (A).
 - RH side shown, LH side similar.
- ←: Front

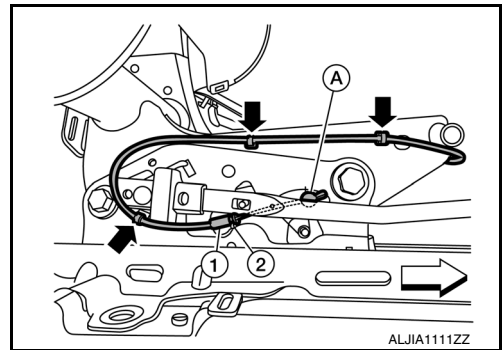

6. Separate the seat cushion release cable (3) from the seat slide release cable (2).

←: Front
7. Release cable end (B) and position the seat cushion release cable (3) aside.
8. Separate the seat slide release cable (2) from the seat frame assembly (1).
9. Remove the seat slide release cable end (A) and the seat slide release cable.

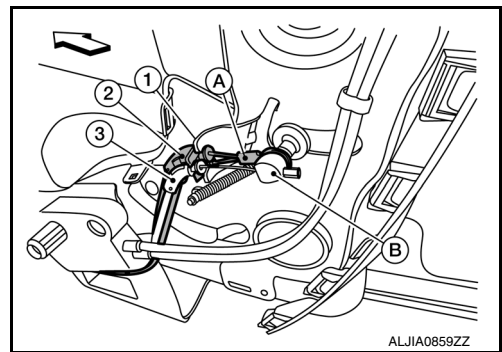

Installation

Installation is in reverse order of removal.

CAUTION:

Route cables correctly for proper function.

RH SEAT

Removal

1. Remove RH seat cushion. Refer to [SE-97, "Seat Cushion"](#).

SECOND ROW SEATS

< REMOVAL AND INSTALLATION >

2. Remove the recline lever.
 - a. Remove snap ring (2) upward using a suitable tool.
 - b. Remove recline lever (3).
3. Remove screw (←) and the seat cushion outer finisher (RH) (1).

○: Pawl

□: Metal clip

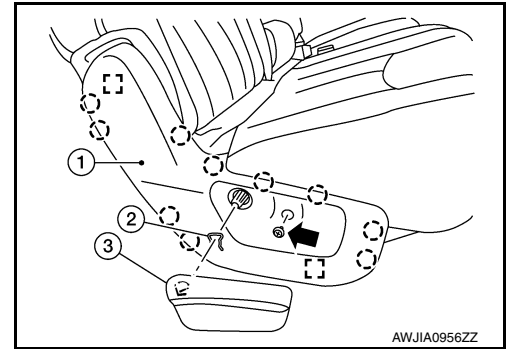

4. Remove screws (←) and lift seat cushion latch finisher (1) to remove.

□: Metal clip

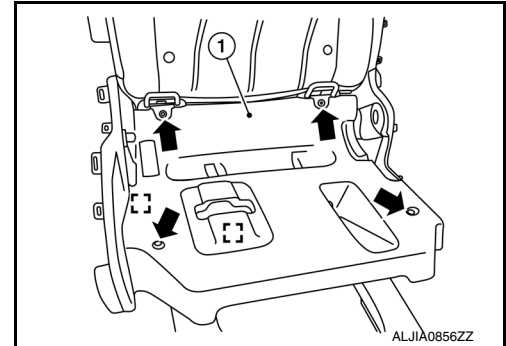

5. Remove two screws and the rear finisher.
6. Remove the seat slide release cable (1) or (2) as necessary, from the seat frame assembly (3).
 - a. Release (←) the seat slide release cable (1).
CAUTION:
Note the cable routing for correct installation.
 - b. Separate the seat slide release cable (1) from the seat frame assembly (3).
 - c. Release cable end (A) and remove the seat slide release cable (1)

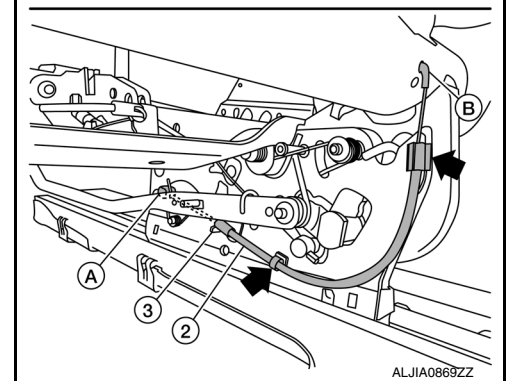
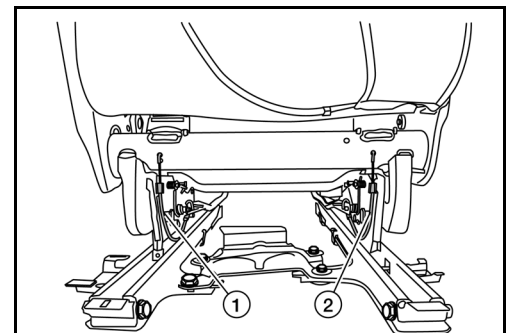

Installation

Installation is in reverse order of removal.

CAUTION:

Route cables correctly for proper function.

Recline Release Cable Assembly

INFOID:000000009727784

LH SEAT

Removal

SECOND ROW SEATS

< REMOVAL AND INSTALLATION >

1. Remove the LH seat seatback. Refer to [SE-126. "LH SEAT : Seatback"](#).

NOTE:

It is not necessary to separate the seatback trim from the seatback pad.

2. Remove screws (A).
3. Release (←) the recline release cable assembly from the seat frame assembly.

CAUTION:

Note the cable routing for correct installation.

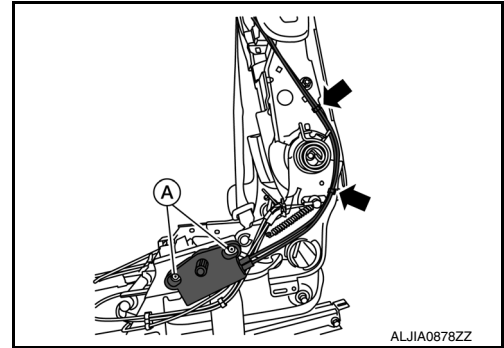

4. Remove the support finishers (2) and (3).
5. Remove the recline release cable assembly (1) from the RH side.
6. Remove the recline release cable assembly (1) from the LH side.

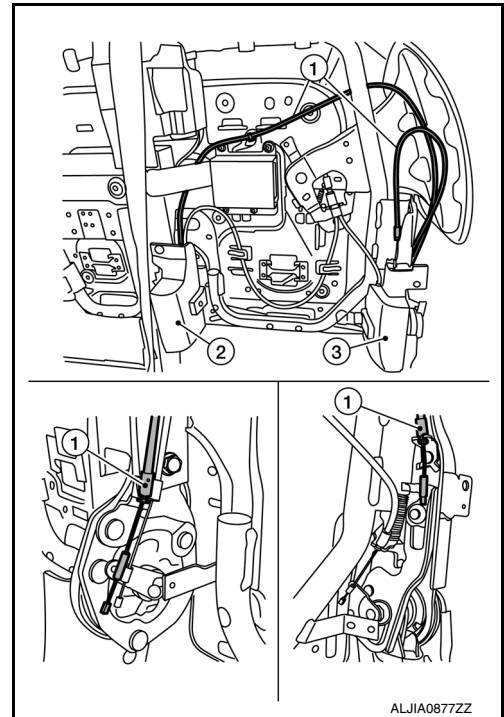

Installation

Installation is in the reverse order of removal.

CAUTION:

Route cables correctly for proper function.

RH SEAT

Removal

1. Remove the RH seat seatback. Refer to [SE-129. "RH SEAT : Seatback"](#).

NOTE:

It is not necessary to separate the seatback trim from the seatback pad.

2. Remove the support finisher.

SECOND ROW SEATS

< REMOVAL AND INSTALLATION >

3. Remove the recline release cable assembly screws (A).
4. Release (←) the recline release cable assembly (1) from the seat frame assembly.
CAUTION:
Note the cable routing for correct installation.
5. Remove the recline release cable assembly (1) from routing guide (B).
6. Remove the recline release cable assembly end (C) and the recline release cable assembly (1).

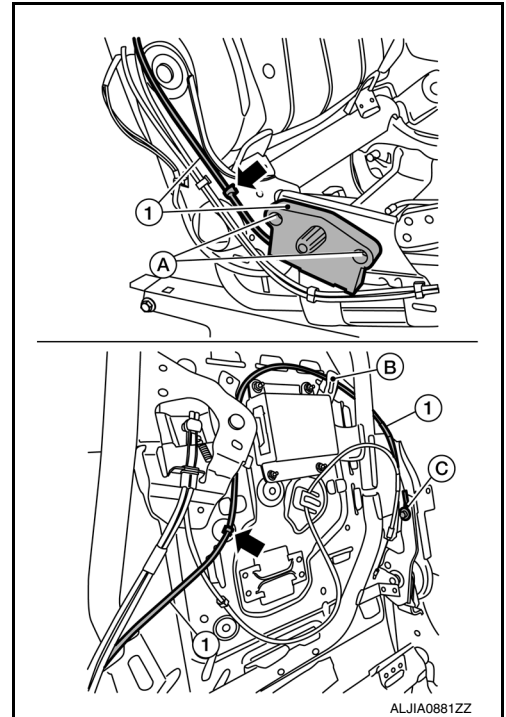

Installation

Installation is in the reverse order of removal.

CAUTION:
Route cables correctly for proper function.

EZ Entry Cable

INFOID:000000009727785

LH SEAT

Removal

1. Remove LH seat seatback. Refer to [SE-126. "LH SEAT : Seatback"](#).
NOTE:
It is not necessary to separate the seatback trim from the seatback pad.
2. Remove support finishers (2) and (3).
3. Remove EZ entry cable (1) from routing guides (←).
CAUTION:
Note the cable routing for correct installation
4. Remove the EZ entry cable (1) from the RH side.
5. Remove the EZ entry cable (1) from the LH side.
6. Remove the EZ entry cable.

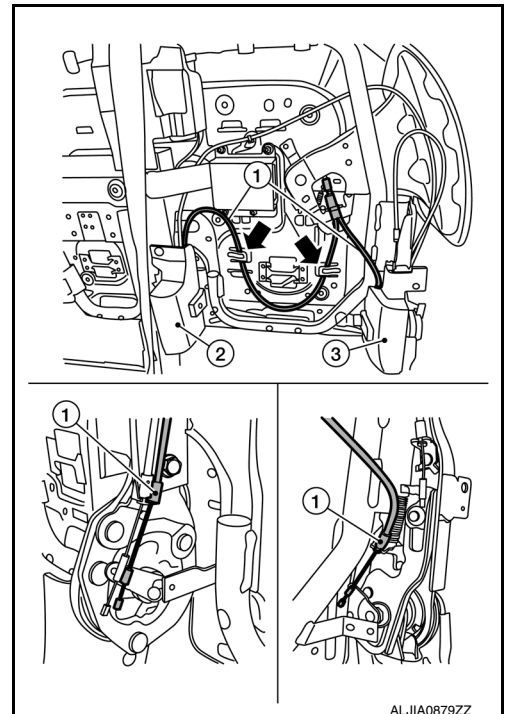

SECOND ROW SEATS

< REMOVAL AND INSTALLATION >

Installation

Installation is in the reverse order of removal.

CAUTION:

Route cables correctly for proper function.

RH SEAT

Removal

1. Remove the RH seatback. Refer to [SE-129, "RH SEAT : Seatback"](#).

NOTE:

It is not necessary to separate the seatback trim from the seatback pad.

2. Remove the support finisher.
3. Remove the EZ entry cable (3) from the routing guide (C).

CAUTION:

Note the cable routing for correct installation.

4. Release (←) the EZ entry cable (3) from the seat frame assembly.
5. Remove the track tilt release cable (2) from the seat frame assembly (1) and release cable end (A).
6. Remove cable end (B) and the EZ entry cable (3).

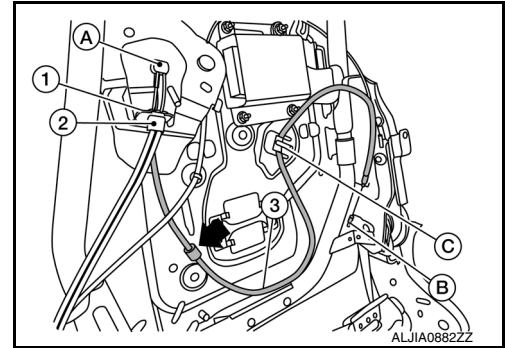

Installation

Installation is in the reverse order of removal.

CAUTION:

Route cables correctly for proper function.

RH Seat Track Tilt Release Cable

INFOID:000000009727786

Removal

1. Remove the RH seat seatback. Refer to [SE-129, "RH SEAT : Seatback"](#).

NOTE:

It is not necessary to separate the seatback trim from the seatback pad.

A
B
C
D
E
F
G
H
I
K
L
M
N
O
P

SE

SECOND ROW SEATS

< REMOVAL AND INSTALLATION >

2. Release (←) the track tilt release cable (1) from the seat frame assembly.
CAUTION:
Note the cable routing for correct installation.
3. Remove the track tilt release cable (1) from the seat frame assembly (2) and release cable ends (A).
4. Remove the track tilt release cable (1).

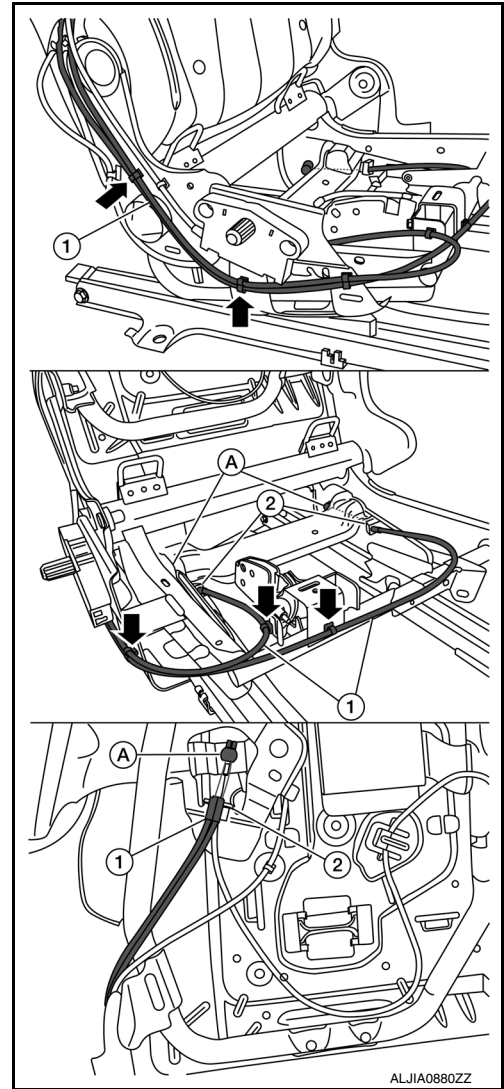

Installation

Installation is in the reverse order of removal.

CAUTION:
Route cables correctly for proper function.

THIRD ROW SEATS

< REMOVAL AND INSTALLATION >

THIRD ROW SEATS

Exploded View

INFOID:000000009727787

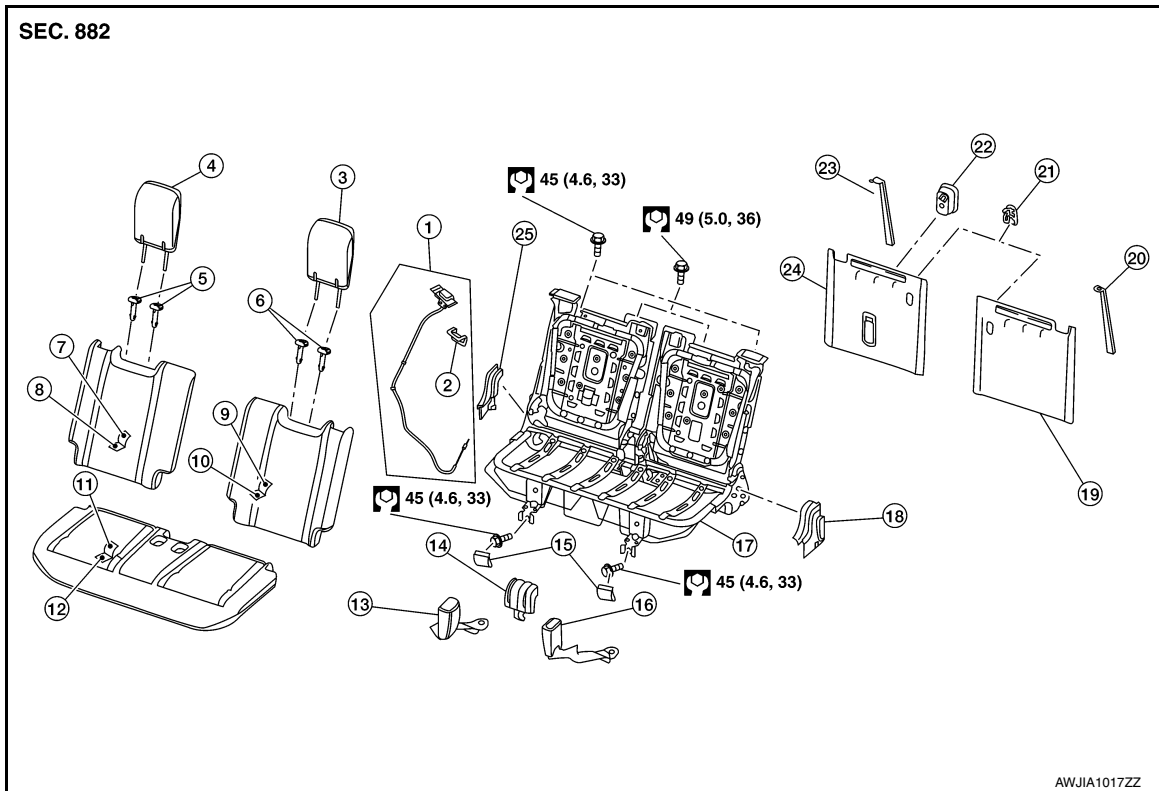

- | | | |
|---|--|------------------------------|
| 1. Seatback release lever and cable (LH/RH) | 2. Seatback release lever finisher (LH/RH) | 3. Headrest (LH) |
| 4. Headrest (RH) | 5. Headrest holders (RH) | 6. Headrest holders (LH) |
| 7. Seatback trim (RH) | 8. Seatback pad (RH) | 9. Seatback trim (LH) |
| 10. Seatback pad (LH) | 11. Seat cushion trim | 12. Seat cushion pad |
| 13. Seat belt buckle (RH) | 14. Seat hinge finisher (center) | 15. Seat bolt finisher |
| 16. Seat belt buckle (LH) | 17. Seat frame assembly | 18. Seat hinge finisher (LH) |
| 19. Seatback board (LH) | 20. Seatback pull strap (LH) | 21. Seatback cargo hook |
| 22. Tether anchor finisher | 23. Seatback pull strap (RH) | 24. Seatback board (RH) |
| 25. Seatback hinge finisher (RH) | | |

Removal and Installation

INFOID:000000009727788

CAUTION:

- Before removal and installation, use shop cloths to protect parts from damage.
- During removal and installation, an assistant is required to protect against injury or damage.

REMOVAL

1. Release the pawls and remove the seat bolt finishers.
2. Remove the seat front bolts.
3. Pull the seatback release lever and fold down the seatbacks (LH/RH).
4. Remove the storage box. Refer to [INT-33. "STORAGE BOX : Removal and Installation"](#).
5. Remove the four bolts, then remove the jack and jack bracket as an assembly.

A
B
C
D
E
F
G
H
I

SE

K
L
M
N
O
P

THIRD ROW SEATS

< REMOVAL AND INSTALLATION >

6. Release the clip (A) and remove the rear side cover (1).
LH side shown, RH side similar
↔: Front

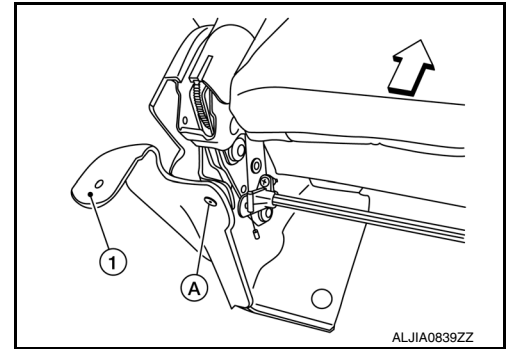

7. Remove the two seat belt buckle anchor bolts. Refer to [SB-17, "Third Row Seat Belt"](#).
8. Remove the seat rear bolts.
9. Remove the third row seat from the vehicle.

INSTALLATION

Installation is in the reverse order of removal.

NOTE:

- When installing the third row seat, tighten the bolts in the order shown.
- Tighten the seat bolts to specification. Refer to [SE-107, "Exploded View"](#).

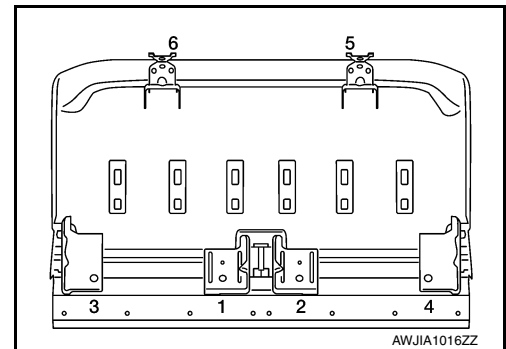

FRONT SEAT

< UNIT DISASSEMBLY AND ASSEMBLY >

UNIT DISASSEMBLY AND ASSEMBLY

FRONT SEAT

Exploded View

INFOID:000000009727789

DRIVER SEAT WITH CLIMATE CONTROL

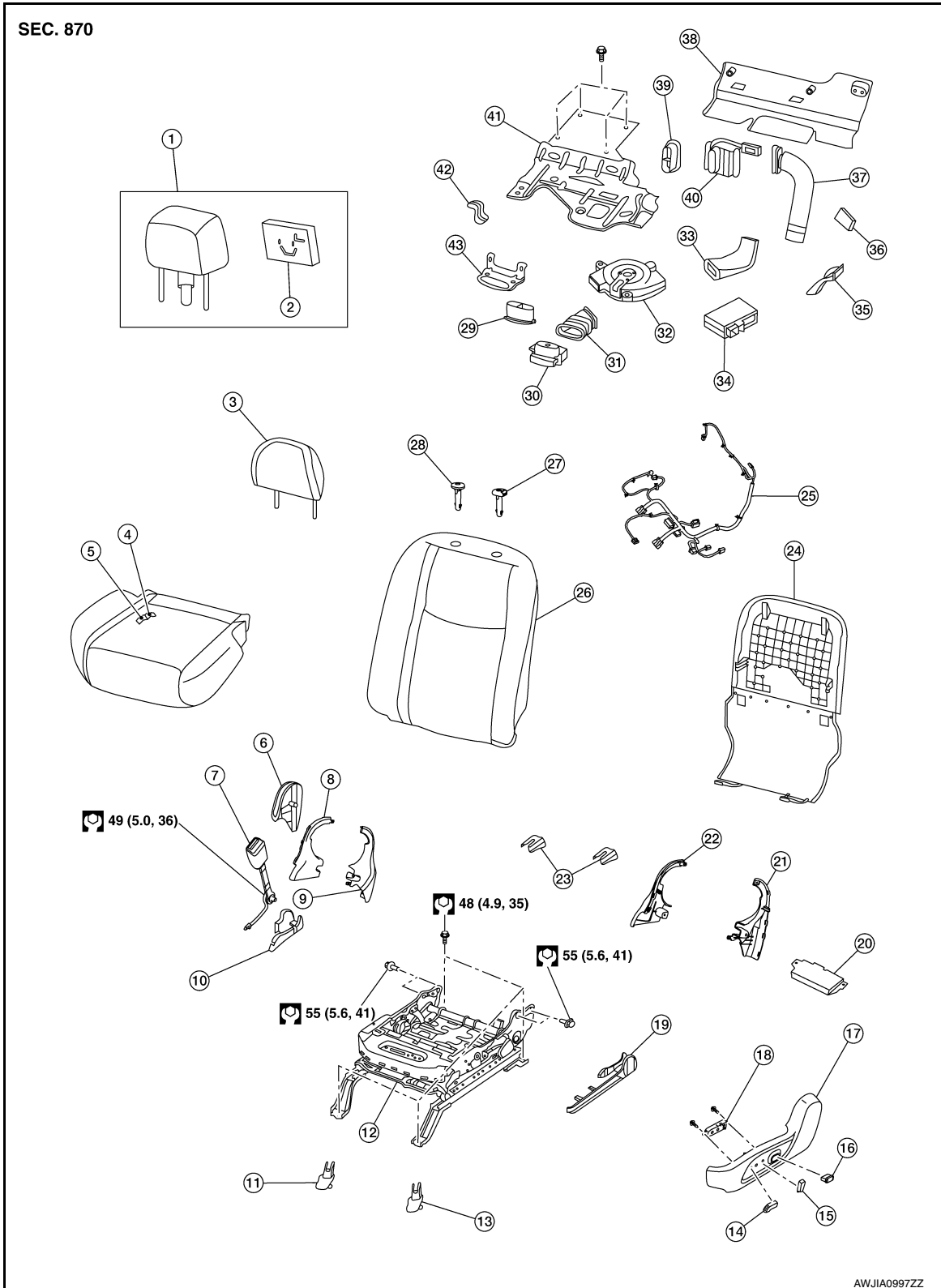

A
B
C
D
E
F
G
H
I
SE
K
L
M
N
O
P

FRONT SEAT

< UNIT DISASSEMBLY AND ASSEMBLY >

- | | | |
|--|---|---|
| 1. Headrest assembly with display unit | 2. Headrest display unit | 3. Headrest without display unit |
| 4. Seat cushion trim | 5. Seat cushion pad | 6. Seat cushion outer finisher (RH) |
| 7. Seat belt buckle | 8. Seat cushion inner finisher (RH) (front) | 9. Seat cushion inner finisher (RH) (rear) |
| 10. Slide finisher outer (RH) | 11. Front slide finisher (RH) | 12. Seat frame assembly |
| 13. Front slide finisher (LH) | 14. Seat slide knob | 15. Seat recline knob |
| 16. Lumbar support switch | 17. Seat cushion outer finisher (LH) | 18. Power seat switch |
| 19. Slide finisher outer (LH) | 20. Power seat control unit | 21. Seat cushion inner finisher (LH) (rear) |
| 22. Seat cushion inner finisher (LH) (front) | 23. Rear slide finisher | 24. Seatback board |
| 25. Seat harness | 26. Seatback assembly | 27. Headrest holder (locked) |
| 28. Headrest holder (free) | 29. Thermal electric device nozzle | 30. Seat cushion thermal electric device |
| 31. Lower blower duct | 32. Blower motor with filter | 33. Angle duct |
| 34. Climate controlled seat control unit | 35. Thermal electric device clip | 36. Upper blower duct clip |
| 37. Upper blower duct | 38. Lower rear cover | 39. Thermal electric device nozzle |
| 40. Seatback thermal electric device | 41. Blower motor bracket | 42. Thermal electric device harness bracket |
| 43. Thermal electric device bracket | | |

FRONT SEAT

< UNIT DISASSEMBLY AND ASSEMBLY >

DRIVER SEAT WITHOUT CLIMATE CONTROL

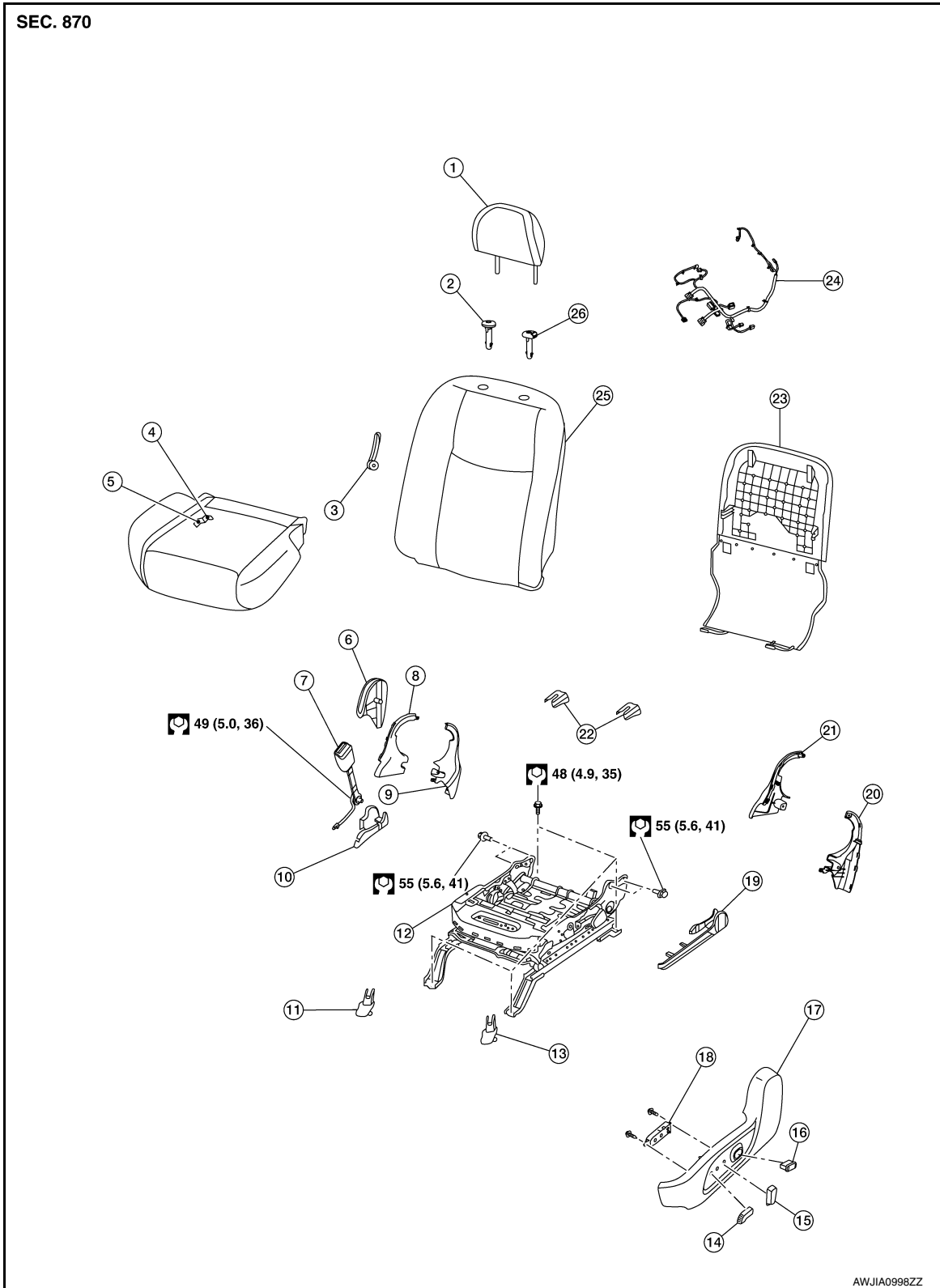

- | | | |
|-------------------------------|---|--|
| 1. Headrest | 2. Headrest holder (free) | 3. Lumbar lever (if equipped) |
| 4. Seat cushion trim | 5. Seat cushion pad | 6. Seat cushion outer finisher (RH) |
| 7. Seat belt buckle | 8. Seat cushion inner finisher (RH) (front) | 9. Seat cushion inner finisher (RH) (rear) |
| 10. Slide finisher outer (RH) | 11. Front slide finisher (RH) | 12. Seat frame assembly |
| 13. Front slide finisher (LH) | 14. Seat slide knob | 15. Seat recline knob |

FRONT SEAT

< UNIT DISASSEMBLY AND ASSEMBLY >

- | | | |
|---|---|--|
| 16. Lumbar support switch (if equipped) | 17. Seat cushion outer finisher (LH) | 18. Power seat switch |
| 19. Slide finisher outer (LH) | 20. Seat cushion inner finisher (LH) (rear) | 21. Seat cushion inner finisher (LH) (front) |
| 22. Rear slide finisher | 23. Seatback board | 24. Seat harness |
| 25. Seatback assembly | 26. Headrest holder (locked) | |

DRIVER SEAT - MANUAL

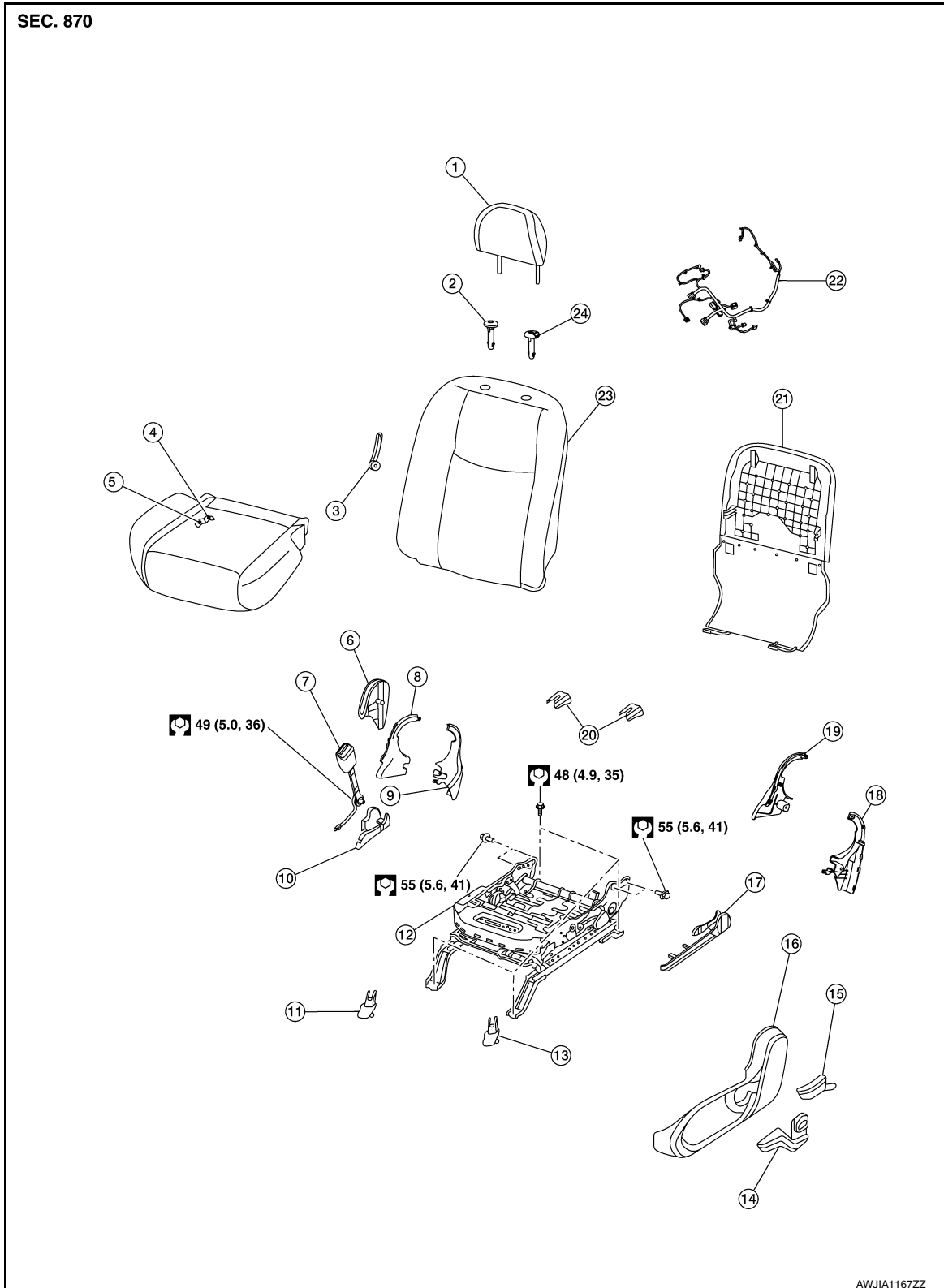

FRONT SEAT

< UNIT DISASSEMBLY AND ASSEMBLY >

1. Headrest	2. Headrest holder (free)	3. Lumbar lever	A
4. Seat cushion trim	5. Seat cushion pad	6. Seat cushion outer finisher (RH)	
7. Seat belt buckle	8. Seat cushion inner finisher (RH) (front)	9. Seat cushion inner finisher (RH) (rear)	B
10. Slide finisher outer (RH)	11. Front slide finisher (RH)	12. Seat frame assembly	
13. Front slide finisher (LH)	14. Lift lever	15. Recline lever finisher	C
16. Seat cushion outer finisher (LH)	17. Slide finisher outer (LH)	18. Seat cushion inner finisher (LH) (rear)	
19. Seat cushion inner finisher (LH) (front)	20. Rear slide finisher	21. Seatback board	D
22. Seat harness	23. Seatback assembly	24. Headrest holder (locked)	E

E

F

G

H

I

SE

K

L

M

N

O

P

FRONT SEAT

< UNIT DISASSEMBLY AND ASSEMBLY >

PASSENGER SEAT WITH CLIMATE CONTROL

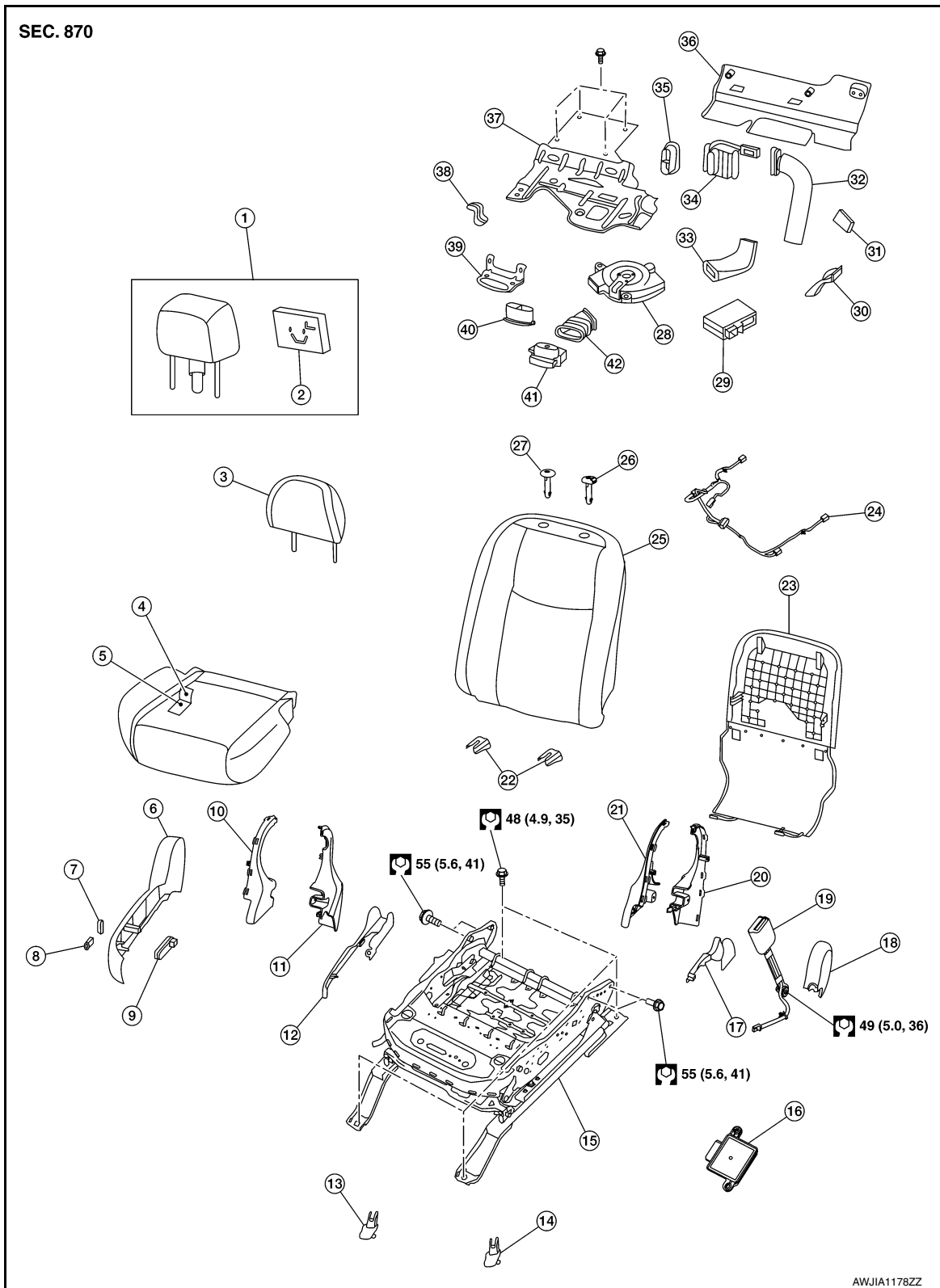

- | | | |
|--|---|-------------------------------------|
| 1. Headrest assembly with display unit | 2. Headrest display unit | 3. Headrest without display unit |
| 4. Seat cushion trim | 5. Seat cushion pad | 6. Seat cushion outer finisher (RH) |
| 7. Seat recline knob | 8. Seat slide knob | 9. Power seat switch |
| 10. Seat cushion inner finisher (RH) (front) | 11. Seat cushion inner finisher (RH) (rear) | 12. Slide finisher outer (RH) |
| 13. Front slide finisher (RH) | 14. Front slide finisher (LH) | 15. Seat frame assembly |

FRONT SEAT

< UNIT DISASSEMBLY AND ASSEMBLY >

16. Occupant Classification System control unit (except Mexico)	17. Slide finisher outer (LH)	18. Seat cushion outer finisher (LH)
19. Seat belt buckle	20. Seat cushion inner finisher (LH) (rear)	21. Seat cushion inner finisher (LH) (front)
22. Rear slide finisher	23. Seatback board	24. Seat harness
25. Seatback assembly	26. Headrest holder (locked)	27. Headrest holder (free)
28. Blower motor with filter	29. Climate controlled seat control unit	30. Thermal electric device clip
31. Upper blower duct clip	32. Upper blower duct	33. Angle duct
34. Seatback thermal electric device	35. Thermal electric device nozzle	36. Lower rear cover
37. Thermal electric device bracket	38. Thermal electric device harness bracket	39. Blower motor bracket
40. Thermal electric device nozzle	41. Seat cushion thermal electric device	42. Lower blower duct

A

B

C

D

E

F

G

H

I

SE

K

L

M

N

O

P

FRONT SEAT

< UNIT DISASSEMBLY AND ASSEMBLY >

PASSENGER SEAT WITHOUT CLIMATE CONTROL

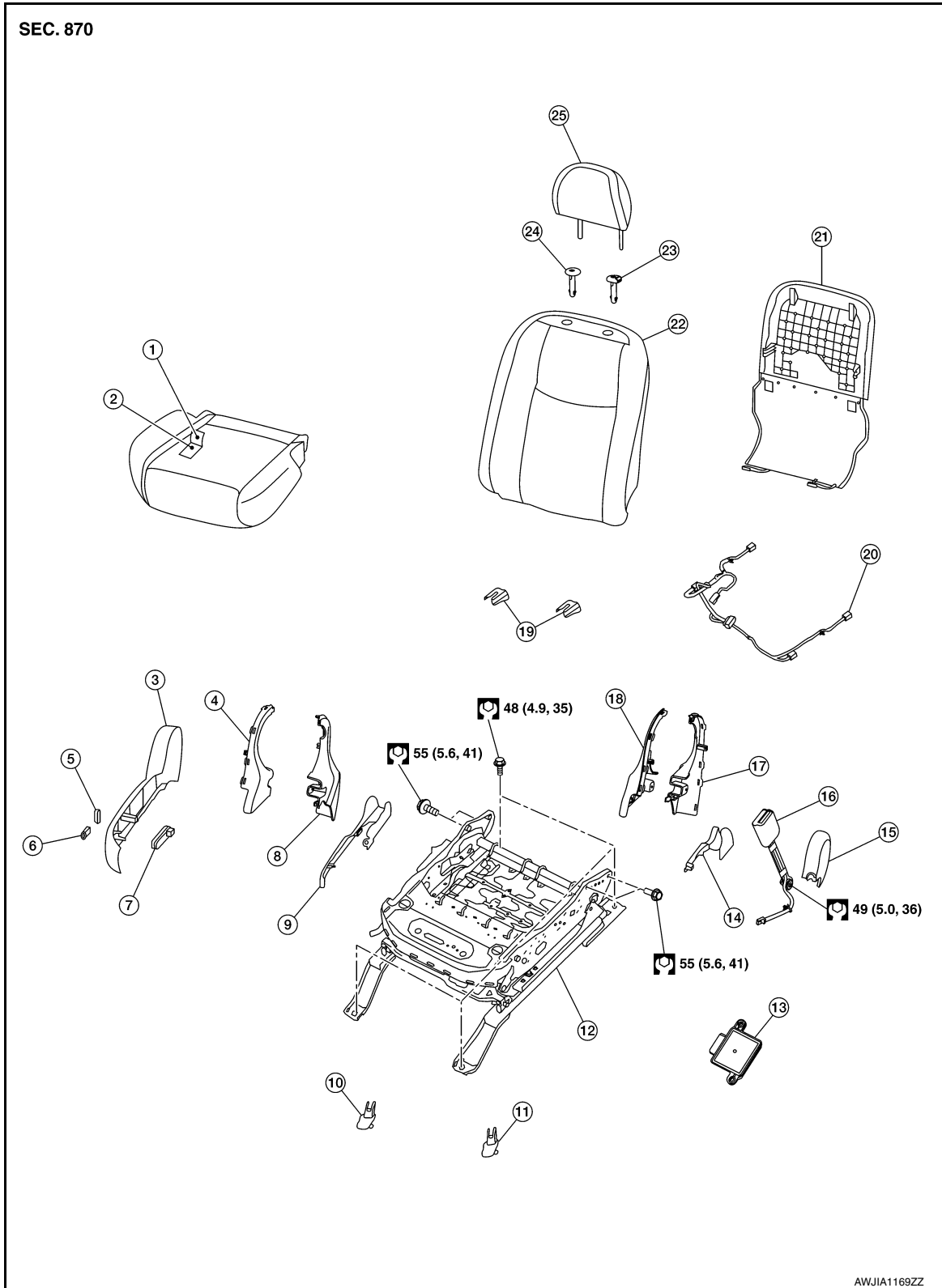

- | | | |
|---|--|-------------------------------------|
| 1. Seat cushion trim | 2. Seat cushion pad | 3. Seat cushion outer finisher (RH) |
| 4. Seat cushion inner finisher (RH) (front) | 5. Seat recline knob | 6. Seat slide knob |
| 7. Power seat switch | 8. Seat cushion inner finisher (RH) (rear) | 9. Slide finisher outer (RH) |
| 10. Front slide finisher (RH) | 11. Front slide finisher (LH) | 12. Seat frame assembly |

FRONT SEAT

< UNIT DISASSEMBLY AND ASSEMBLY >

- | | | |
|---|---|--|
| 13. Occupant Classification System control unit (except Mexico) | 14. Slide finisher outer (LH) | 15. Seat cushion outer finisher (LH) |
| 16. Seat belt buckle | 17. Seat cushion inner finisher (LH) (rear) | 18. Seat cushion inner finisher (LH) (front) |
| 19. Rear slide finisher | 20. Seat harness | 21. Seatback board |
| 22. Seatback assembly | 23. Headrest holder (locked) | 24. Headrest holder (free) |
| 25. Headrest | | |

PASSENGER SEAT - MANUAL

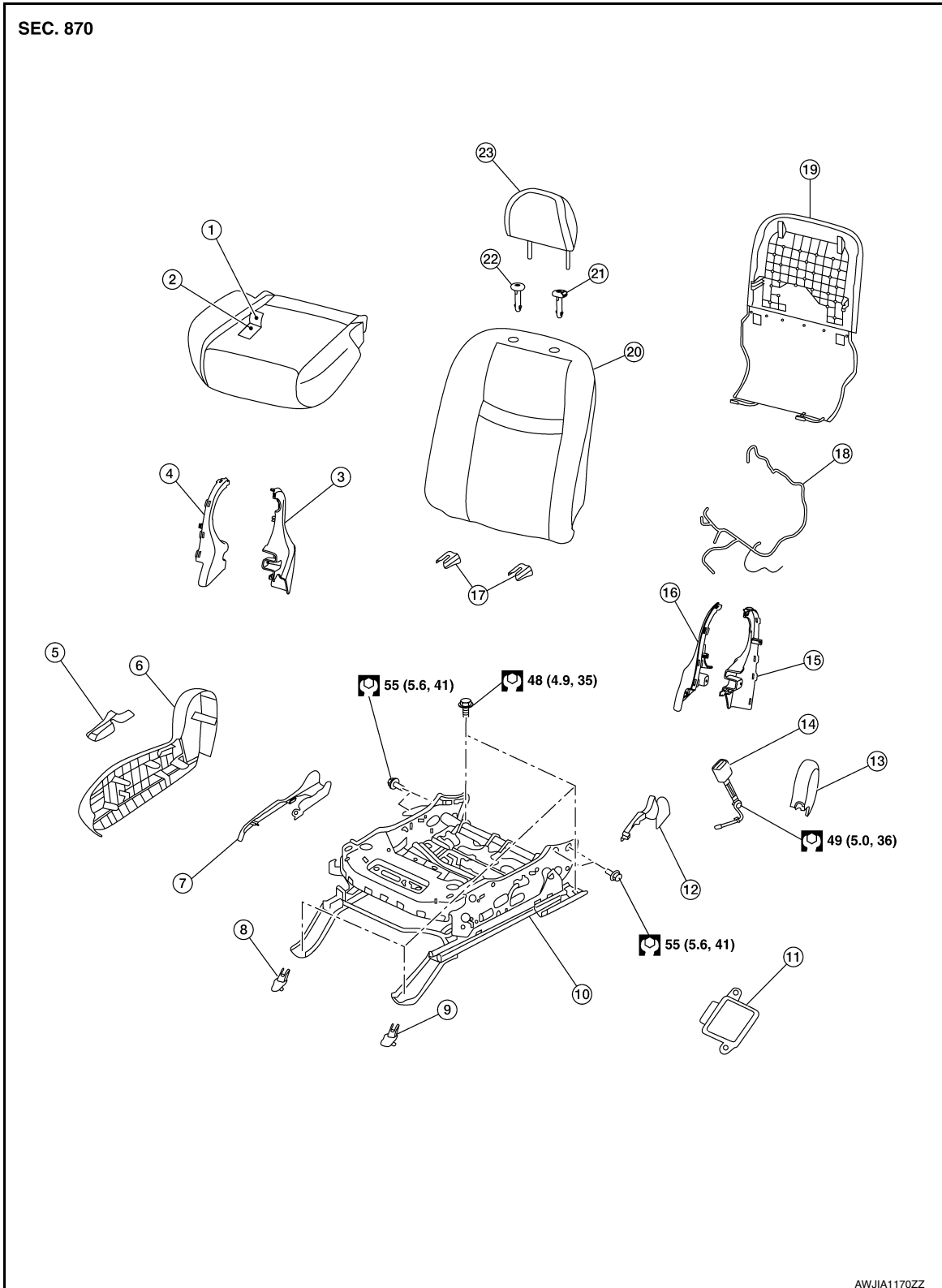

A
B
C
D
E
F
G
H
I
SE
K
L
M
N
O
P

FRONT SEAT

< UNIT DISASSEMBLY AND ASSEMBLY >

- | | | |
|--|---|---|
| 1. Seat cushion trim | 2. Seat cushion pad | 3. Seat cushion inner finisher (RH) (rear) |
| 4. Seat cushion inner finisher (RH) (front) | 5. Recline lever finisher | 6. Seat cushion outer finisher (RH) |
| 7. Slide finisher outer (RH) | 8. Front slide finisher (RH) | 9. Front slide finisher (LH) |
| 10. Seat frame assembly | 11. Occupant Classification System control unit (except Mexico) | 12. Slide finisher outer (LH) |
| 13. Seat cushion outer finisher (LH) | 14. Seat belt buckle | 15. Seat cushion inner finisher (LH) (rear) |
| 16. Seat cushion inner finisher (LH) (front) | 17. Rear slide finisher | 18. Seat harness |
| 19. Seatback board | 20. Seatback assembly | 21. Headrest holder (locked) |
| 22. Headrest holder (free) | 23. Headrest | |

Seatback

INFOID:000000009727790

DISASSEMBLY

WARNING:

Do not leave any objects (screwdrivers, tools, etc.) on the seat during seatback repair. It can lead to personal injury if the side air bag module should accidentally deploy.

CAUTION:

- **Before servicing, turn the ignition switch OFF, disconnect both battery terminals then wait at least three minutes.**
- **Always work from the side or back of the seatback, do not work in front of seat.**
- **Do not use air tools or electric tools for servicing the seat assembly.**
- **Do not insert any objects into the side air bag module.**
- **Do not attempt to disassemble the side air bag module.**
- **Do not expose the side air bag module to temperatures exceeding 90°C (194°F).**
- **Do not expose the side air bag module to any oil, grease, detergent or water.**
- **During disassembly, do not damage the seatback board, connectors, retainers, clips, module harness or the side air bag module.**

NOTE:

- If the vehicle has been involved in a collision and the side air bag module has deployed, the seatback must be replaced.
 - Front seat (LH) shown; front seat (RH) similar.
1. Remove front seat. Refer to [SE-86. "Removal and Installation"](#).
 2. Remove the seatback board. Refer to [SE-87. "Seatback Board"](#).
 3. Remove the headrest.

For headrest without display:

Press the headrest holder lock button and lift headrest up to remove from the seat back assembly.

For headrest with display:







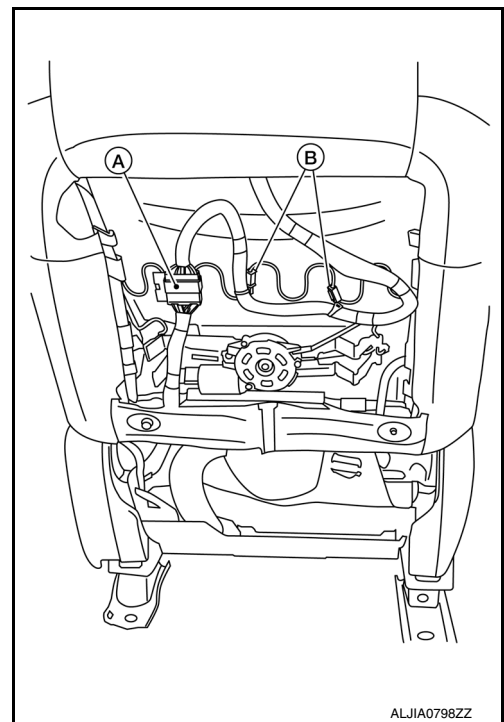

FRONT SEAT

< UNIT DISASSEMBLY AND ASSEMBLY >

1. Release the headrest harness clips (B) and disconnect the harness connector (A).
2. Press the headrest holder lock button and lift headrest up to remove from the seatback assembly.
3. Route the headrest harness through the top of the seatback assembly.



ALJIA0798ZZ

4. Remove the seat cushion outer finisher (LH) (1).
 - a. For power seat:
 - i. Remove screw (A).
 - ii. Release metal clip (B) from the seat frame assembly (2), as shown.
 -  Metal clip
 - iii. Release pawls and metal clip (C), and remove.
 -  Pawl
 -  Metal clip
 - iv. Disconnect the harness connectors from the power seat switch and the lumbar support switch (if equipped).
 - b. For manual seat:
 - i. Remove screw (A).
 - ii. Release pawl and remove recline lever finisher (front seat (RH))
 - iii. Release metal clip (B) from the seat frame assembly (2), as shown.
 -  Metal clip
 - iv. Release pawls and metal clip (C), and remove.
 -  Pawl
 -  Metal clip
5. Release pawls and metal clip, and remove the seat cushion outer finisher (RH).
 -  Pawl
 -  Metal clip

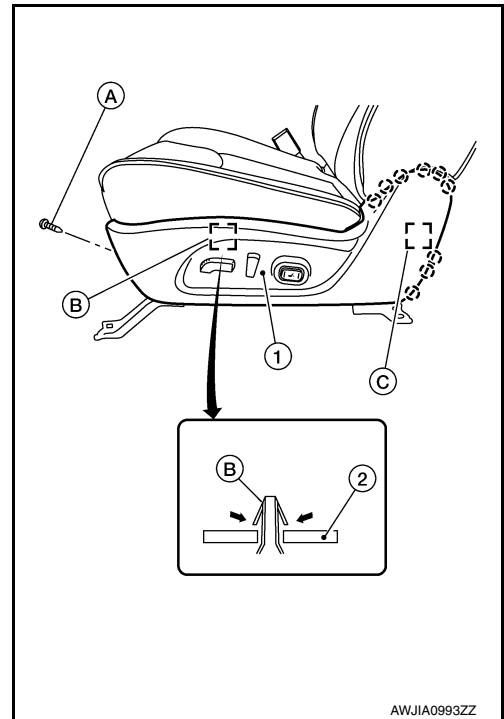

AWJIA0993ZZ

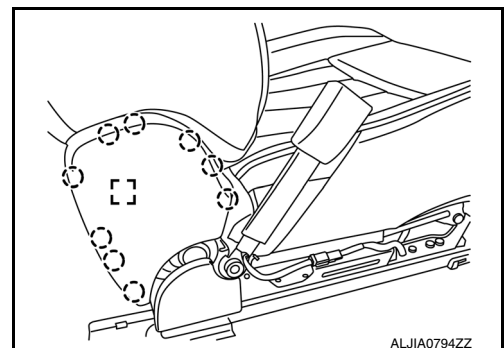

ALJIA0794ZZ

A
B
C
D
E
F
G
H
I
SE
K
L
M
N
O
P

FRONT SEAT

< UNIT DISASSEMBLY AND ASSEMBLY >

6. Remove the lumbar lever (if equipped).
7. Unclip the side air bag module harness from the seat frame assembly.
NOTE:
Take note of harness routing and attachment location for correct installation.
8. Disconnect the harness connector from the lumbar support motor (if equipped) and unclip the harness from the seatback assembly.
NOTE:
Take note of harness routing and attachment location for correct installation.
9. Disconnect the harness connector for the seatback heater (if equipped).
NOTE:
Take note of harness routing and attachment location for correct installation.
10. Disconnect the harness connector from the seatback thermal electric device (if equipped) and unclip the harness from the seatback assembly.
NOTE:
Take note of harness routing and attachment location for correct installation.
11. Remove the upper blower duct tie straps from the seatback thermal electric device and discard, then remove the upper blower duct from the seatback thermal electric device (if equipped).
NOTE:
Do not reuse the tie straps for thermal electric device upper or upper blower duct, discard them.
12. Remove the seat cushion inner finisher (LH/RH) (front) and seat cushion inner finisher (LH/RH) (rear).
13. Remove bolts (A) on both sides of the seatback assembly (1).

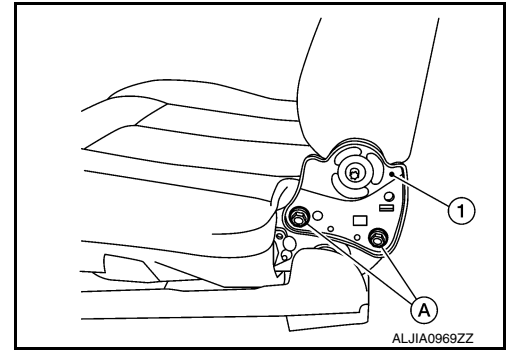

ASSEMBLY

- Install all seatback assembly bolts, then tighten evenly in the order shown.
- Tighten the seatback assembly bolts to specification. Refer to [SE-109. "Exploded View"](#).

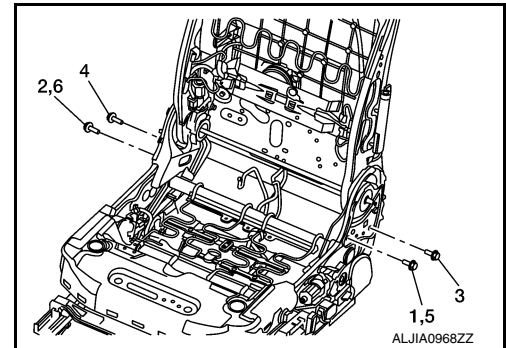

CAUTION:

- Always route side air bag module harness in original location. Replace any deformed or damaged clips with same type and color. Always install clips in the original location in the harness.
- After work is completed, check that no system malfunction is detected causing the air bag warning lamp to illuminate.
- If a malfunction is detected by the air bag warning lamp after repair or replacement of the malfunction parts, perform the SRS final check. Refer to [SRC-16. "SRS Final Check"](#).

Seat Cushion

INFOID:000000009727791

DISASSEMBLY

WARNING:

FRONT SEAT

< UNIT DISASSEMBLY AND ASSEMBLY >

Do not leave any objects (screwdrivers, tools, etc.) on the seat during seat cushion repair. It can lead to personal injury if the side air bag module should accidentally deploy.

CAUTION:

- Before servicing, turn the ignition switch OFF, disconnect both battery terminals and wait at least three minutes.
- Always work from the side or back of the seatback assembly, do not work in front of seat.
- Do not use air tools or electric tools for servicing the seat assembly.

NOTE:

Front seat (LH) shown; front seat (RH) similar.

1. Remove the front seat. Refer to [SE-86. "Removal and Installation"](#).

2. Remove the seat cushion outer finisher (LH) (1).

a. For power seat:

i. Remove screw (A).

ii. Release metal clip (B) from the seat frame assembly (2), as shown.

 Metal clip

iii. Release pawls and metal clip (C), and remove.

 Pawl

 Metal clip

iv. Disconnect the harness connectors from the power seat switch and the lumbar support switch (if equipped).

b. For manual seat:

i. Remove screw (A).

ii. Release pawl and remove recline lever finisher (front seat (RH))

iii. Release metal clip (B) from the seat frame assembly (2), as shown.

 Metal clip

iv. Release pawls and metal clip (C), and remove.

 Pawl

 Metal clip

3. Release pawls and metal clip and remove the seat cushion outer finisher (RH).

 Pawl

 Metal clip

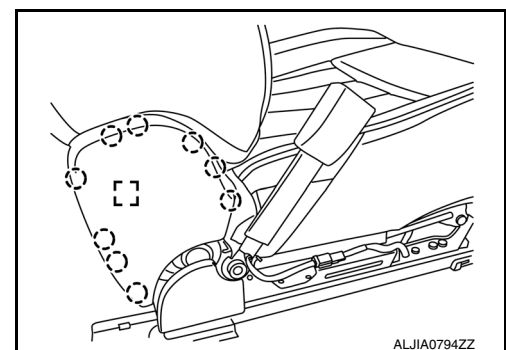
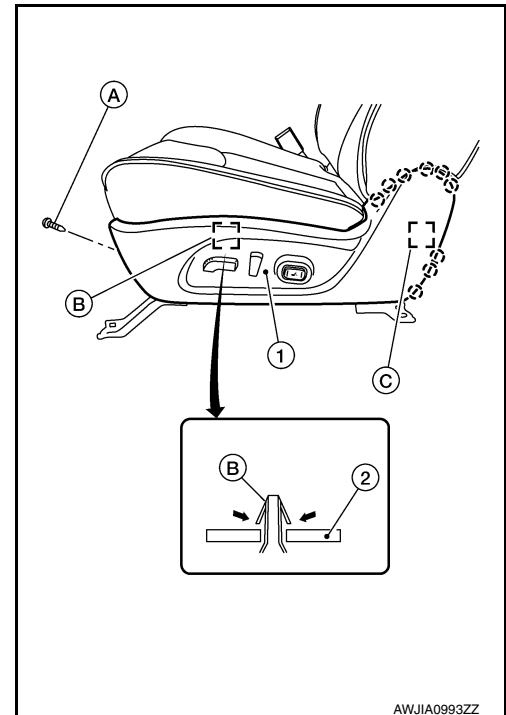

4. Release the two seatback board J-clip retainers from the seat frame assembly.

5. Remove the four screws and the seat cushion lower rear finisher.

6. Release the seven seat cushion J-clips holding the seat cushion trim to the seat frame assembly.

7. Remove the seat cushion trim and seat cushion pad as an assembly from the seat frame assembly.

8. Remove the hog rings and separate the seat cushion trim and seat cushion pad.

NOTE:

Remove all pieces of hog rings and discard them.

ASSEMBLY

Assembly is in the reverse order of disassembly.

FRONT SEAT

< UNIT DISASSEMBLY AND ASSEMBLY >

- Install new hog rings on the seat cushion trim in original positions.
- Use only one hog ring in each designated location.
- Make sure hog rings are correctly fastened around both the seat cushion trim and seat cushion pad wires.
- Use NISSAN standard hog rings and tools to assemble.
- Make sure hook fastener is pressed into place after seat cushion trim is assembled.
- Smooth out all wrinkles during assembly.

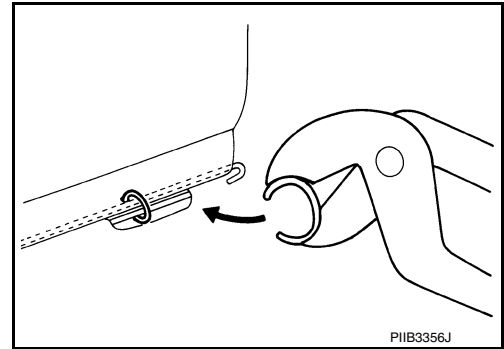

CAUTION:

- Always route side air bag module harness in original location. Replace any deformed or damaged clips with same type and color. Always install clips in the original location in the harness.
- After work is completed, check that no system malfunction is detected causing the air bag warning lamp to illuminate.
- If a malfunction is detected by the air bag warning lamp after repair or replacement of the malfunction parts, perform the SRS final check. Refer to [SRC-16, "SRS Final Check"](#).

SECOND ROW SEAT

< UNIT DISASSEMBLY AND ASSEMBLY >

SECOND ROW SEAT

Exploded View

INFOID:00000009727792

LH SEAT

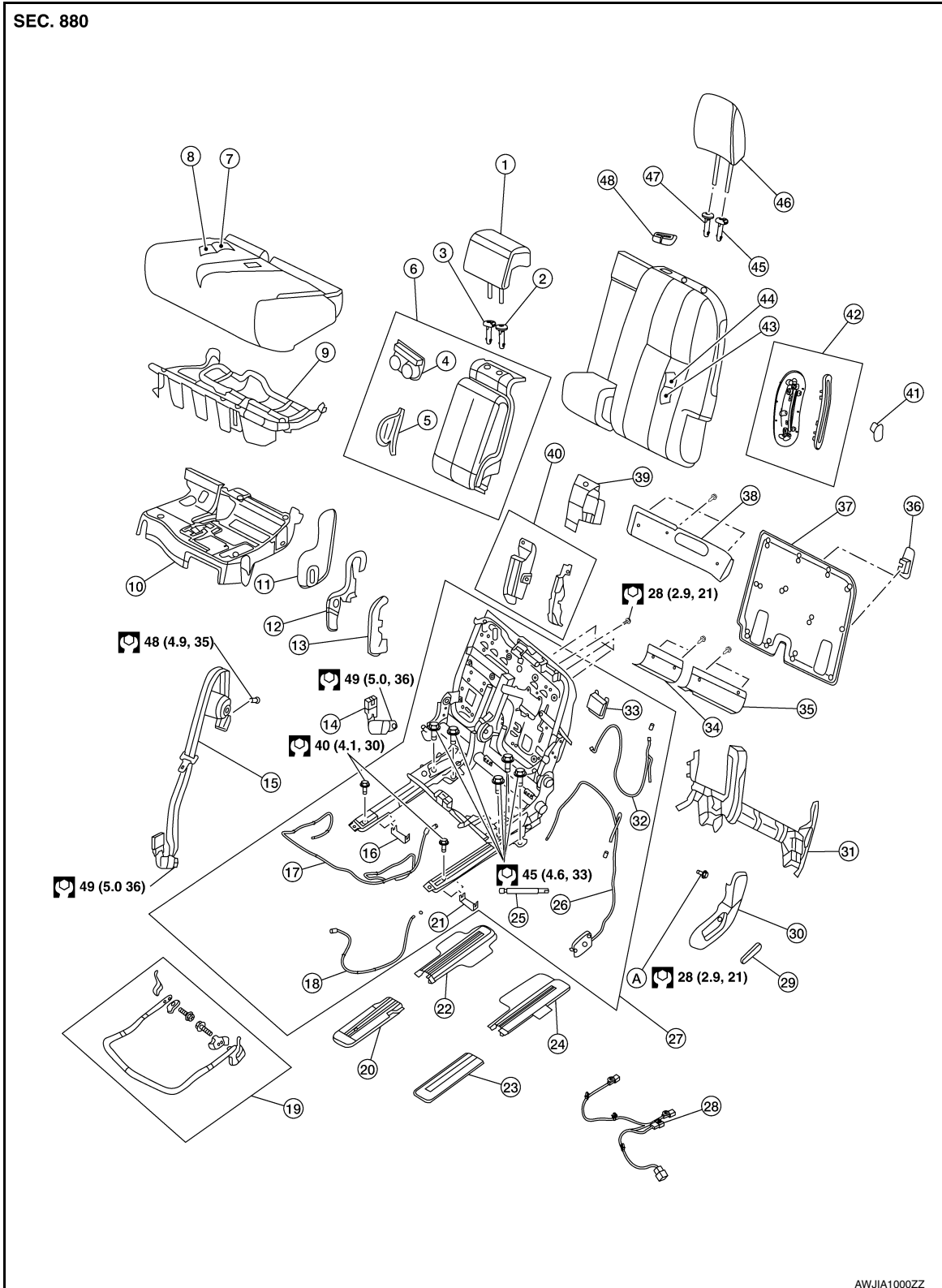

- | | | |
|------------------|--------------------------------|----------------------------------|
| 1. Headrest (RH) | 2. Headrest holder (free) (RH) | 3. Headrest holder (locked) (RH) |
| 4. Cup holder | 5. Armrest hinge finisher | 6. Armrest assembly |

A
B
C
D
E
F
G
H
I
SE
K
L
M
N
O
P

SECOND ROW SEAT

< UNIT DISASSEMBLY AND ASSEMBLY >

- | | | |
|---------------------------------------|------------------------------------|------------------------------------|
| 7. Seat cushion trim | 8. Seat cushion pad | 9. Seat cushion frame |
| 10. Seat cushion latch finisher | 11. Outer finisher (RH) | 12. Inner finisher (RH) |
| 13. Recline finisher (center) | 14. Seat belt buckle (RH) | 15. Seat belt retractor (center) |
| 16. Seat slide clip (RH) | 17. Seat slide release cable | 18. Seat cushion release cable |
| 19. Seat slide control lever assembly | 20. Front slide finisher (RH) | 21. Seat slide clip (LH) |
| 22. Rear slide finisher (RH) | 23. Front slide finisher (LH) | 24. Rear slide finisher (LH) |
| 25. Support strut | 26. Recline release cable assembly | 27. Seat frame assembly |
| 28. Seat harness | 29. Recline lever | 30. Seat cushion outer finisher LH |
| 31. Rear finisher | 32. EZ entry cable | 33. Dampener |
| 34. Trim stiffener (RH) | 35. Trim stiffener (LH) | 36. Tether anchor finisher |
| 37. Seatback board | 38. EPP upper panel | 39. Seat belt retractor finisher |
| 40. Support finisher (RH) | 41. EZ entry lever finisher | 42. EZ entry finisher |
| 43. Seatback pad | 44. Seatback trim | 45. Headrest holder (locked) (LH) |
| 46. Headrest (LH) | 47. Headrest holder (free) (LH) | 48. Seat belt retractor finisher |
| A. Seat cushion pivot bolt | | |

SECOND ROW SEAT

< UNIT DISASSEMBLY AND ASSEMBLY >

RH SEAT

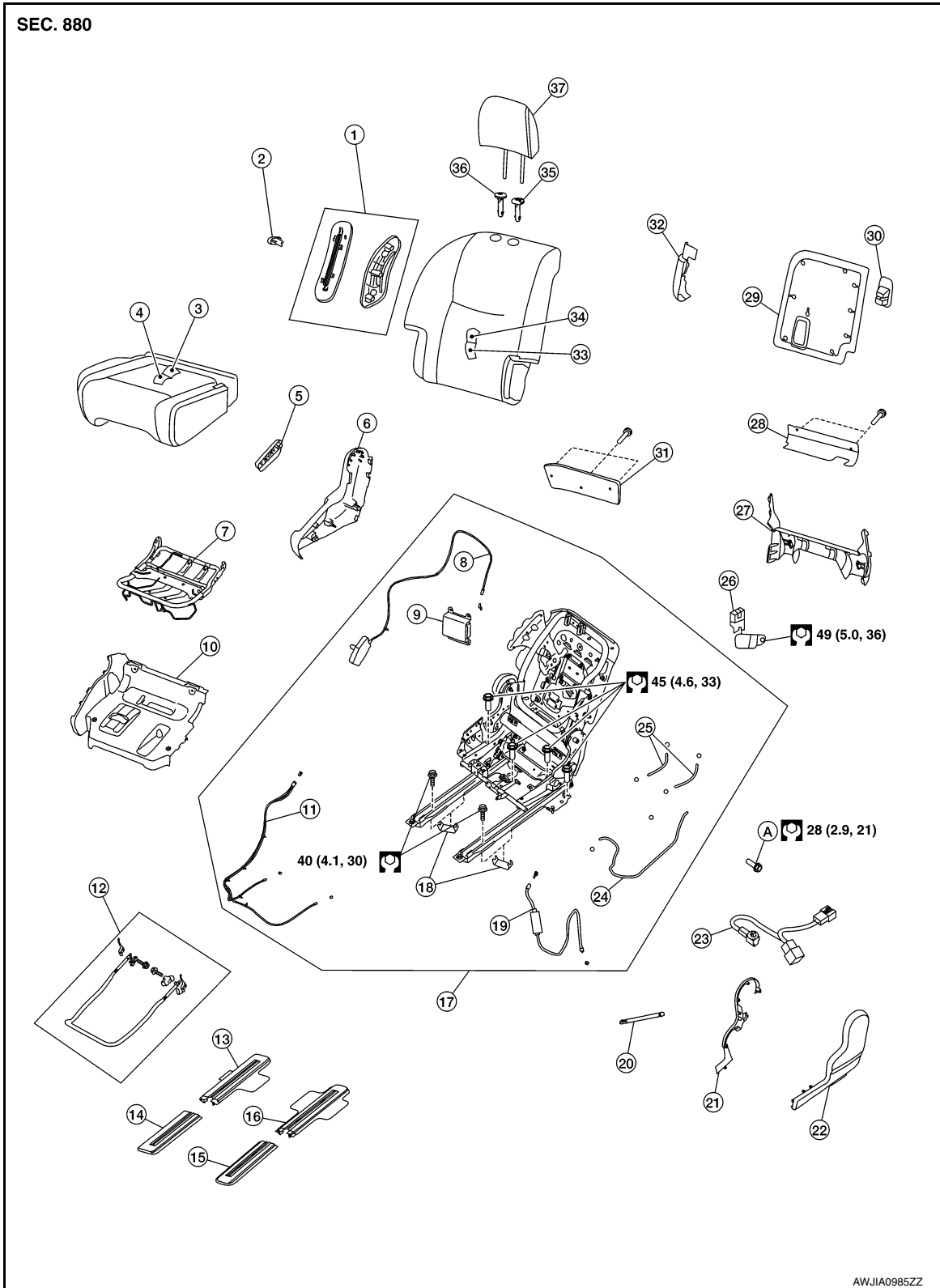

- | | | |
|---------------------------------|-----------------------------------|---------------------------------------|
| 1. EZ entry finisher | 2. EZ entry lever finisher | 3. Seat cushion trim |
| 4. Seat cushion pad | 5. Recline lever | 6. Seat cushion outer finisher (RH) |
| 7. Seat cushion frame | 8. Recline release cable assembly | 9. Dampener |
| 10. Seat cushion latch finisher | 11. Track tilt release cable | 12. Seat slide control lever assembly |
| 13. Rear slide finisher (RH) | 14. Front slide finisher (RH) | 15. Front slide finisher (LH) |
| 16. Rear slide finisher (LH) | 17. Seat frame assembly | 18. Seat slide clip |

A
B
C
D
E
F
G
H
I
SE
K
L
M
N
O
P

SECOND ROW SEAT

< UNIT DISASSEMBLY AND ASSEMBLY >

- | | | |
|------------------------------|------------------------------|--------------------------------|
| 19. EZ entry cable | 20. Support strut | 21. Inner finisher (LH) |
| 22. Outer finisher (LH) | 23. Seat harness | 24. Seat cushion release cable |
| 25. Seat slide release cable | 26. Seat belt buckle | 27. Rear finisher |
| 28. Trim stiffener | 29. Seatback board | 30. Tether anchor finisher |
| 31. EPP upper panel | 32. Support finisher | 33. Seatback pad |
| 34. Seatback trim | 35. Headrest holder (locked) | 36. Headrest holder (free) |
| 37. Headrest | A. Seat cushion pivot bolt | |

LH SEAT

LH SEAT : Seatback

INFOID:000000009727793

DISASSEMBLY

1. Remove the LH seat. Refer to [SE-94. "Removal and Installation"](#).
2. Remove the LH seat cushion. Refer to [SE-97. "Seat Cushion"](#).
3. Remove the armrest assembly. Refer to [SE-96. "Armrest Assembly"](#).
4. Release pawls and metal clip, and remove the outer finisher (RH) (1).

○: Pawl

□: Metal clip

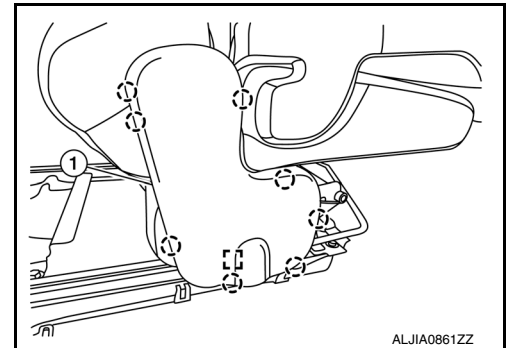

5. Release the seatback heater harness (if equipped) from all attachments.

NOTE:

Take note of harness routing and attachment locations for correct installation.

6. Release pawls and remove the recliner finisher (center) (1).

○: Pawl

7. Release clip.

△: Clip

8. Remove screws (←), then release metal clips and remove the seat cushion latch finisher (2).

□: Metal clip

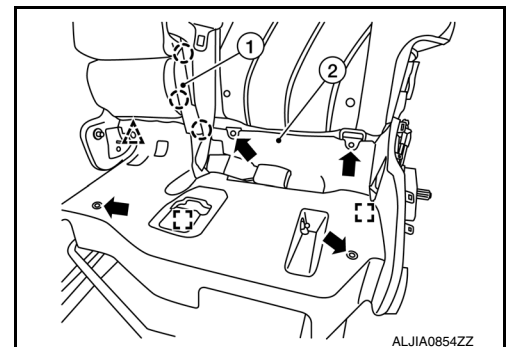

9. Remove screws (←), then release metal clip and remove the rear finisher (1).

□: Metal clip

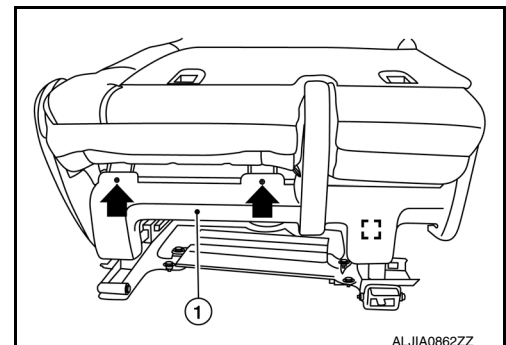

10. Remove seat belt retractor (center) bottom anchor bolt.

11. Remove the headrest (LH).

SECOND ROW SEAT

< UNIT DISASSEMBLY AND ASSEMBLY >

12. Reach up behind the seatback pad, release the headrest holder locks as shown and remove the headrest holders.

CAUTION:

Before removing/installing headrest holder, check its orientation (front/rear and right/left).

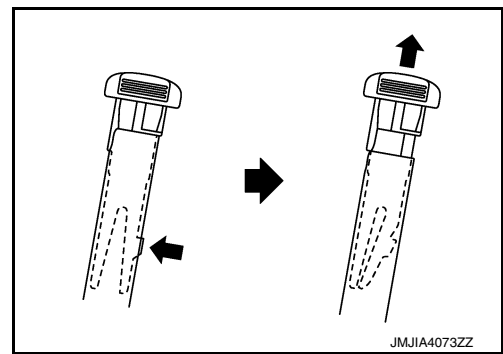

13. Remove the seat belt retractor finisher (1) from seatback (2).

- a. Release pawls using a suitable tool and lift front (←) of seat belt retractor finisher.

○: Pawl

- b. Push on rear (→) of seat belt retractor finisher to remove.

↔: Front

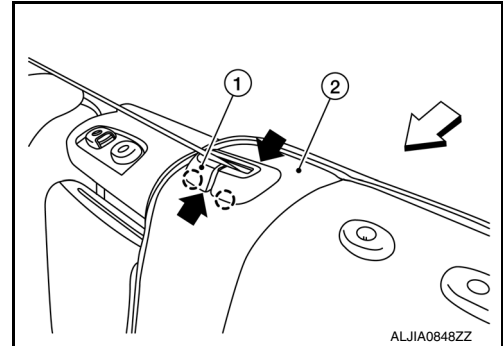

14. Remove EZ entry lever finisher (3) by pulling firmly.

15. Release pawls and remove EZ entry finisher (2) from seatback (1).

○: Pawl

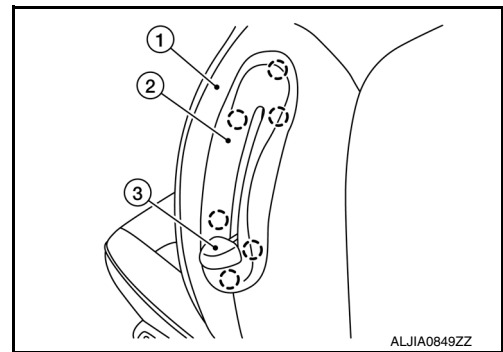

16. Remove the seatback pad and seatback trim (2).

- a. Release the J-clip retainer (←) at the rear lower edge of seatback.

- b. Remove five clips that retain seatback trim in place.

△: Clip

- c. Release retainer strips (A) from the seat frame assembly.

- d. Release clips that retain trim behind EZ entry finisher.

- e. Remove the seatback pad and seatback trim as an assembly from the seat frame assembly (1).

- f. Route the seat belt through the opening in the seatback trim.

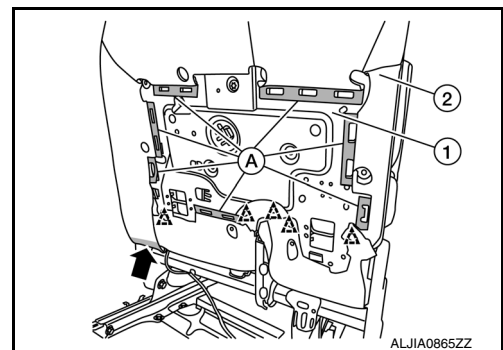

17. Separate the seatback trim (1) from the seatback pad.

- a. Pull seatback trim upward in front to release hook fasteners (A).

- b. Remove hog rings and separate the seatback trim from the seatback pad.

NOTE:

Remove all pieces of hog rings and discard them.

□: Hog ring

- c. Route the seatback heater harness (if equipped) through the opening in the seatback trim.

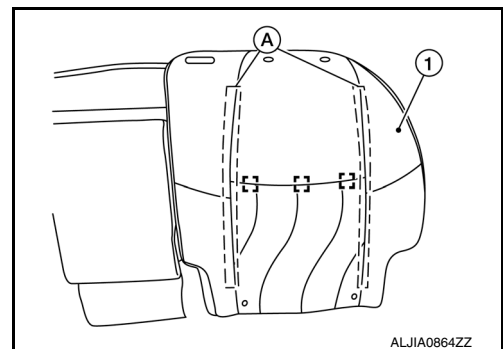

A
B
C
D
E
F
G
H
I
SE
K
L
M
N
O
P

SECOND ROW SEAT

< UNIT DISASSEMBLY AND ASSEMBLY >

ASSEMBLY

Assembly is in the reverse order of disassembly.

- Install new hog rings on the seatback trim in original positions.
- Use only one hog ring in each designated location.
- Make sure hog rings are correctly fastened around both the seatback trim and seatback pad wires.
- Use NISSAN standard hog rings and tools to assemble.
- Make sure hook fastener is pressed into place after seatback trim is assembled.
- Smooth out all wrinkles during assembled.

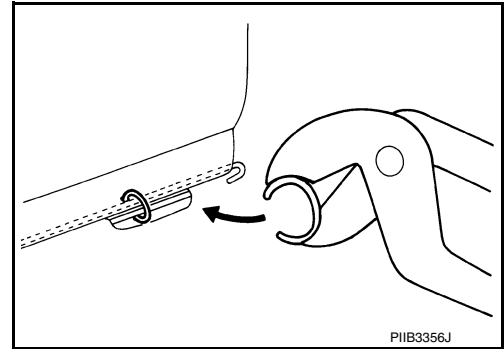

INFOID:000000009727794

LH SEAT : Seat Cushion

DISASSEMBLY

1. Remove the LH seat cushion. Refer to [SE-97, "Seat Cushion"](#).
2. Remove support strut from the LH seat cushion.
3. Remove the seat cushion pad and seat cushion trim (1).
 - a. Unzip the back trim cover and release the J-clip retainers (←).
 - b. Remove four hog rings (A) near seat belt opening, to release seat cushion trim (2).

NOTE:

Remove all pieces of hog rings and discard them.

- c. Remove the seat cushion pad and seat cushion trim as an assembly from the seat cushion frame (3).

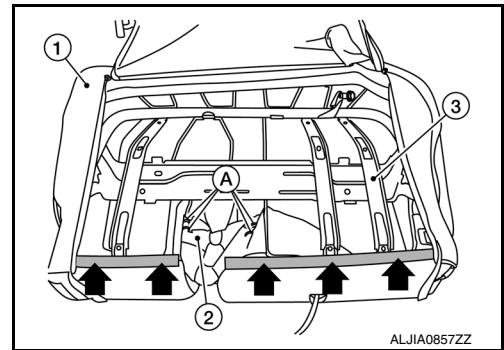

4. Separate the seat cushion trim (1) from the seat cushion pad.
 - a. Pull seat cushion trim up at rear to release hook fastener (A).
←: Front
 - b. Remove hog rings and separate the seat cushion trim from the seat cushion pad.

NOTE:

Remove all pieces of hog rings and discard them.

[□]: Hog ring

- c. Route the seat cushion heater harness (if equipped) through the opening in the seat cushion trim.

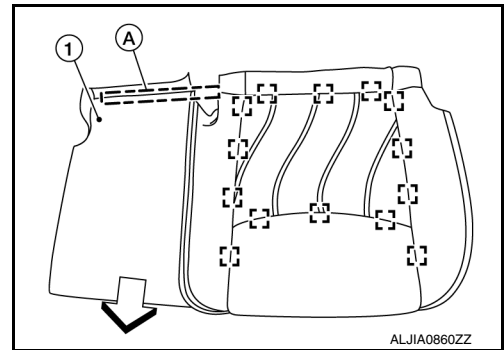

ASSEMBLY

Assembly is in the reverse order of disassembly.

- Install new hog rings on the seat cushion trim in original positions.
- Use only one hog ring in each designated location.
- Make sure hog rings are correctly fastened around both the seat cushion trim and seat cushion pad wires.
- Use NISSAN standard hog rings and tools to assemble.
- Make sure hook fastener is pressed into place after seat cushion trim is assembled.
- Smooth out all wrinkles during assembly.

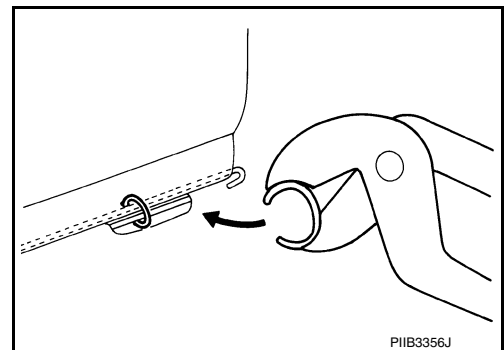

RH SEAT

SECOND ROW SEAT

< UNIT DISASSEMBLY AND ASSEMBLY >

RH SEAT : Seatback

INFOID:00000009727795

DISASSEMBLY

1. Remove RH seat. Refer to [SE-94, "Removal and Installation"](#).
2. Remove RH seat cushion. Refer to [SE-97, "Seat Cushion"](#).
3. Remove the recline lever (3).
 - a. Remove snap ring (2) upward using a suitable tool.
 - b. Remove recline lever.
4. Remove screw (←).
5. Release pawls and metal clips, and remove the seat cushion outer finisher (RH) (1).

○: Pawl

□: Metal clip

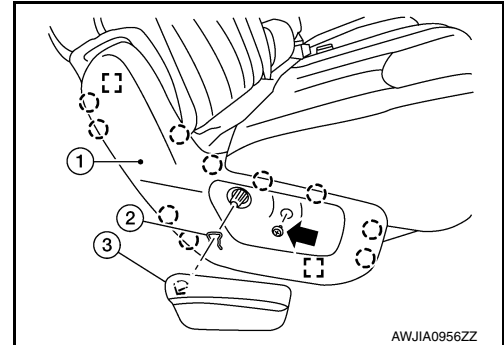

6. Remove screws (←), then release metal clips and remove the seat cushion latch finisher (1).

□: Metal clip

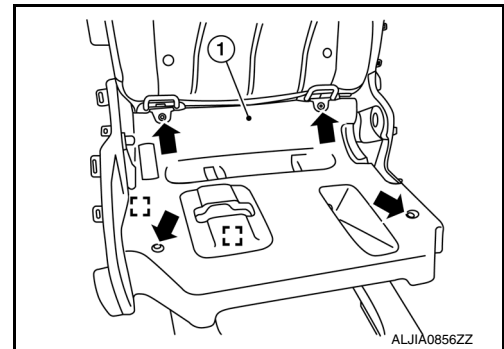

7. Remove the rear finisher.
8. Release the seatback heater harness (if equipped) from attachments.
NOTE:
Note harness attachments and routing location for correct installation.

9. Remove the headrest.
10. Remove EZ entry lever finisher (1) by pulling firmly.
11. Release pawls and remove EZ entry finisher (2) from the seatback (3).

○: Pawl

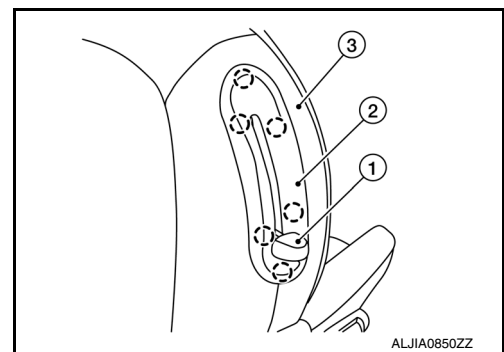

12. Release pawls and remove the tether anchor finisher (2).

○: Pawl

13. Release clips and remove the seatback board (1).

△: Clip

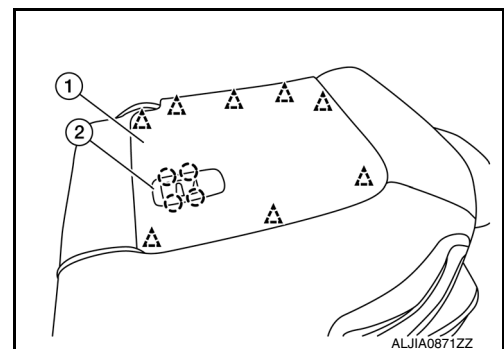

A
B
C
D
E
F
G
H
I

SE

K
L
M
N
O
P

SECOND ROW SEAT

< UNIT DISASSEMBLY AND ASSEMBLY >

14. Remove the seatback pad and seatback trim (1).

- Release the J-clip retainer (←) at the rear lower edge of seatback.
- Remove two clips that retain seatback trim in place.
△: Clip
- Remove two hog rings that retain seatback pad in place.
NOTE:
Remove all pieces of hog rings and discard them.
□: Hog ring
- Release retainer strips (A) from the seat frame assembly (2).
- Release clips that retain trim behind EZ entry finisher.
- Remove the seatback pad and seatback trim as an assembly from the seat frame assembly.

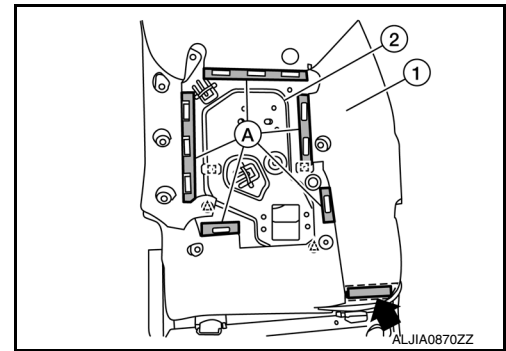

15. Reach up behind the seatback pad, release the headrest holder locks as shown and remove the headrest holders.

CAUTION:

Before removing/installing headrest holder, check its orientation (front/rear and right/left).

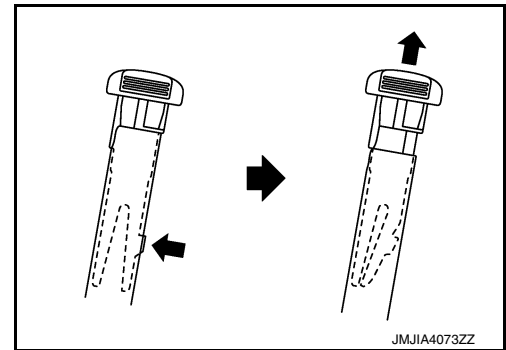

16. Separate the seatback trim (1) from the seatback pad.

- Pull seatback trim upward in front to release hook fasteners (A).
- Remove hog rings and separate the seatback trim from the seatback pad.
NOTE:
Remove all pieces of hog rings and discard them.
□: Hog ring
- Route the seatback heater harness (if equipped) through the opening in the seatback trim.

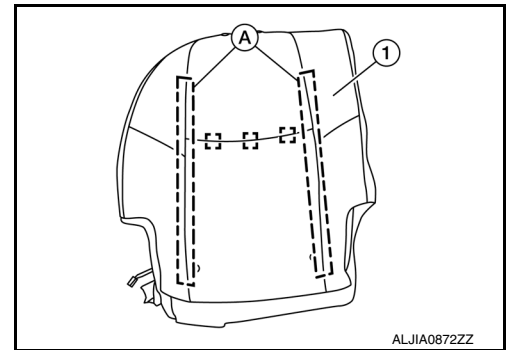

ASSEMBLY

Assembly is in the reverse order of disassembly.

- Install new hog rings on the seatback trim in original positions.
- Use only one hog ring in each designated location.
- Make sure hog rings are correctly fastened around both the seatback trim and seatback pad wires.
- Use NISSAN standard hog rings and tools to assemble.
- Make sure hook fastener is pressed into place after seatback trim is assembled.
- Smooth out all wrinkles during assembled.

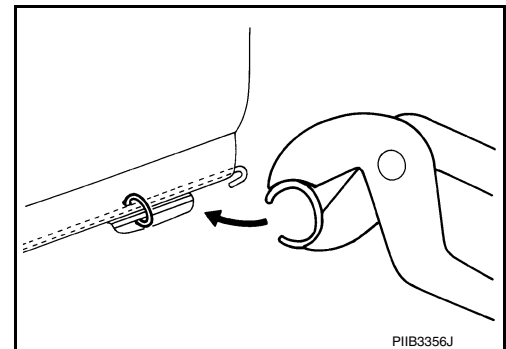

RH SEAT : Seat Cushion

INFOID:000000009727796

DISASSEMBLY

1. Remove RH seat cushion. Refer to [SE-97, "Seat Cushion"](#).
2. Remove support strut from RH seat cushion.

SECOND ROW SEAT

< UNIT DISASSEMBLY AND ASSEMBLY >

3. Remove the seat cushion pad and seat cushion trim (1).
 - a. Unzip the back trim cover and release the J-clip retainer (←).
 - b. Remove the seat cushion pad and seat cushion trim as an assembly from the seat cushion frame (2).

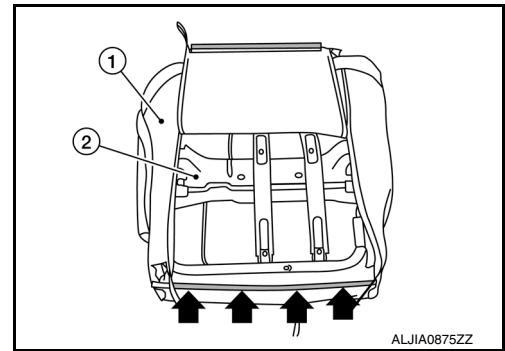

4. Separate the seat cushion trim (1) from the seat cushion pad.
 - a. Remove hog rings and separate the seat cushion trim from the seat cushion pad.

NOTE:
Remove all pieces of hog rings and discard them.

□: Hog ring
←: Front
 - b. Route the seat cushion heater harness (if equipped) through the opening in the seat cushion trim.

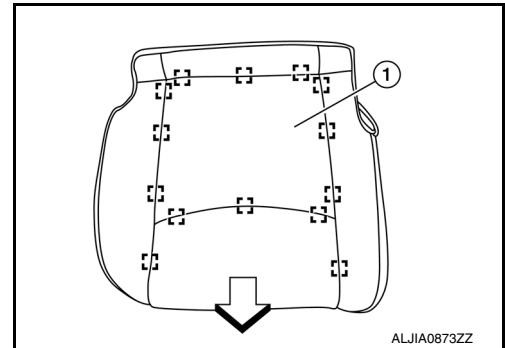

ASSEMBLY

Assembly is in the reverse order of disassembly.

- Install new hog rings on the seat cushion trim in original positions.
- Use only one hog ring in each designated location.
- Make sure hog rings are correctly fastened around both the seat cushion trim and seat cushion pad wires.
- Use NISSAN standard hog rings and tools to assemble.

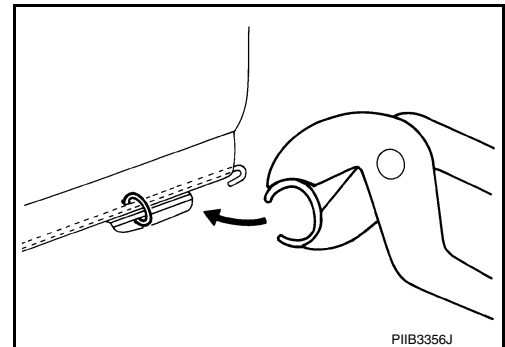

A
B
C
D
E
F
G
H
I
SE
K
L
M
N
O
P

THIRD ROW SEAT

< UNIT DISASSEMBLY AND ASSEMBLY >

THIRD ROW SEAT

Exploded View

INFOID:000000009727797

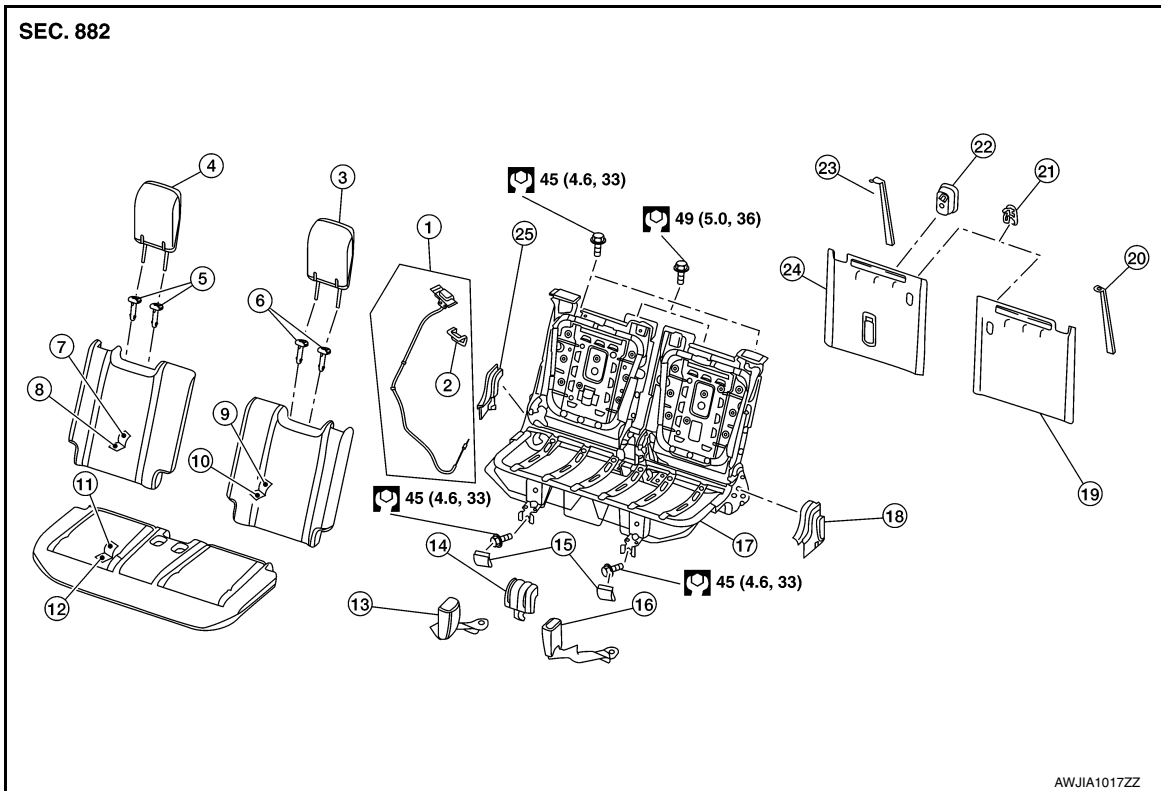

- | | | |
|---|--|------------------------------|
| 1. Seatback release lever and cable (LH/RH) | 2. Seatback release lever finisher (LH/RH) | 3. Headrest (LH) |
| 4. Headrest (RH) | 5. Headrest holders (RH) | 6. Headrest holders (LH) |
| 7. Seatback trim (RH) | 8. Seatback pad (RH) | 9. Seatback trim (LH) |
| 10. Seatback pad (LH) | 11. Seat cushion trim | 12. Seat cushion pad |
| 13. Seat belt buckle (RH) | 14. Seat hinge finisher (center) | 15. Seat bolt finisher |
| 16. Seat belt buckle (LH) | 17. Seat frame assembly | 18. Seat hinge finisher (LH) |
| 19. Seatback board (LH) | 20. Seatback pull strap (LH) | 21. Seatback cargo hook |
| 22. Tether anchor finisher | 23. Seatback pull strap (RH) | 24. Seatback board (RH) |
| 25. Seatback hinge finisher (RH) | | |

Seatback

INFOID:000000009727798

SEATBACK

Disassembly

1. Remove the third row seat. Refer to [SE-107, "Removal and Installation"](#).
2. Release the pawls and remove the tether anchor finisher.
3. Remove the screw and the seatback cargo hook.
4. Press both headrest holder lock buttons in and lift headrest up, and remove.

THIRD ROW SEAT

< UNIT DISASSEMBLY AND ASSEMBLY >

5. Remove the seatback board.

NOTE:

Backside of seatback board shown for clarity.

- Release the hook fastener (A) along the upper edge.
- Release three clips (B) that retain the seatback board to the seat frame assembly.
- Release the remaining clips in the order shown.

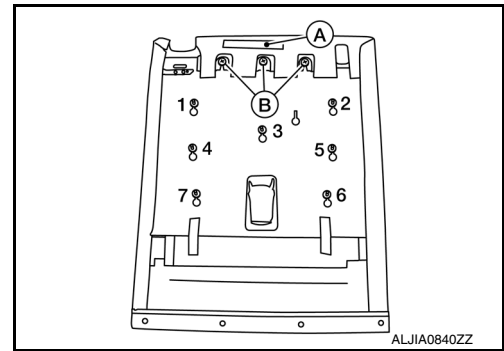

6. Remove the seatback trim and seatback pad.

- Release retainer strip (A) from the seat frame assembly slots (B) on the top edge of the seat frame assembly.
- Repeat at the lower and LH/RH edges.

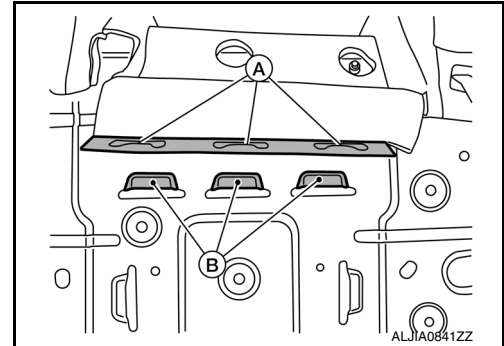

- c. Reach up behind the seatback pad, release the headrest holder locks as shown and remove the headrest holders.

CAUTION:

Before removing/installing headrest holder, check its orientation (front/rear and right/left).

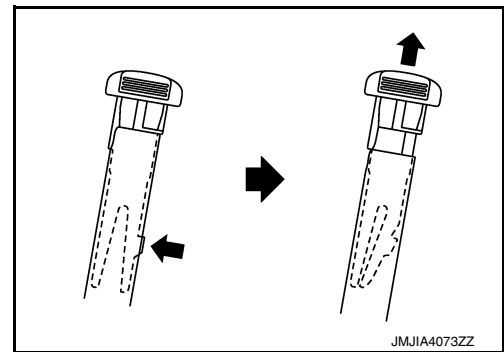

- d. Remove the seatback pad and seatback trim as an assembly from the seat frame assembly.

7. Separate the seatback trim from the seatback pad.

- Pull seatback trim upward in front to release hook fasteners (A).
- Remove hog rings and separate the seatback trim from the seatback pad.

NOTE:

Remove all pieces of hog rings and discard them.

[] Hog ring

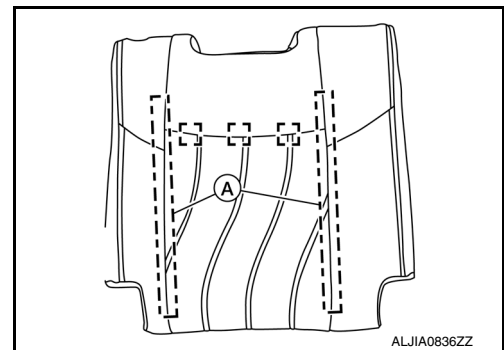

8. Remove the screw and the seatback pull strap.

A
B
C
D
E
F
G
H
I
SE
K
L
M
N
O
P

THIRD ROW SEAT

< UNIT DISASSEMBLY AND ASSEMBLY >

9. Remove the seatback release lever and cable (1).

CAUTION:

Note the cable routing for correct installation.

- Remove the screw (A) and release the cable clip (B) from the seat frame assembly.
- Rotate cable end (C) and release from the seat frame assembly.
- Rotate cable end (D) and remove the seatback release lever and cable.

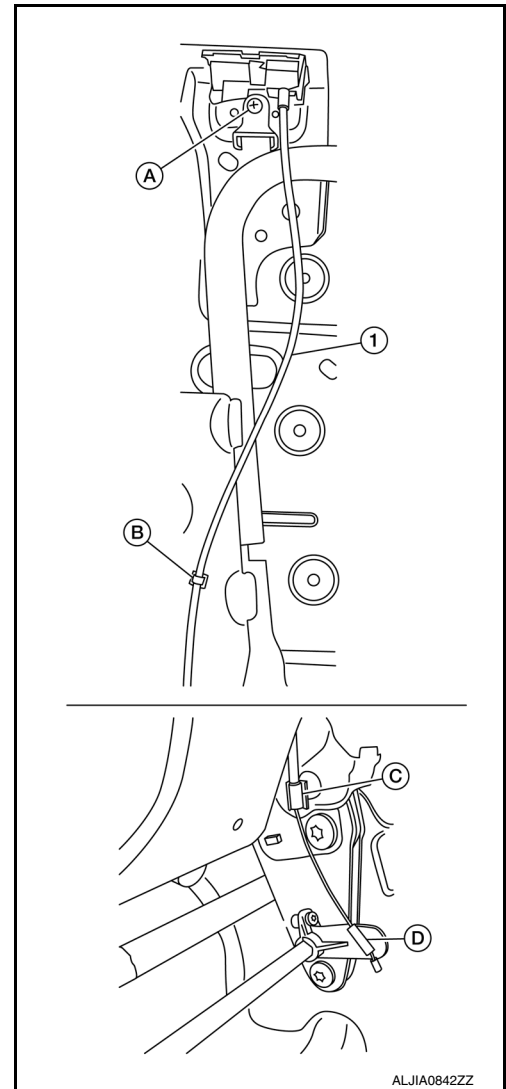

Assembly

Assembly is in the reverse order of disassembly.

- Install new hog rings on the seatback trim in original positions.
- Use only one hog ring in each designated location.
- Make sure hog rings are correctly fastened around both the seatback trim and seatback pad wires.
- Use NISSAN standard hog rings and tools to assemble.
- Make sure hook fastener is pressed into place after seatback trim is assembled.
- Smooth out all wrinkles during assembly.

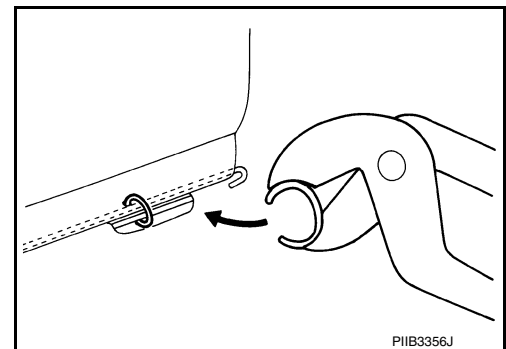

CAUTION:

Route cable correctly for proper function.

Seat Cushion

INFOID:000000009727799

DISASSEMBLY

1. Remove the third row seat. Refer to [SE-107, "Removal and Installation"](#).

THIRD ROW SEAT

< UNIT DISASSEMBLY AND ASSEMBLY >

2. Remove seat cushion pad and seat cushion trim.
 - a. Release the J-clips (A) holding the seat cushion trim to the seat frame (B).
 - b. Release the elastic band and remove the seat belt buckles (LH/RH) from the seat cushion.
 - c. Remove the seat cushion pad and seat cushion trim as an assembly from the seat frame assembly.

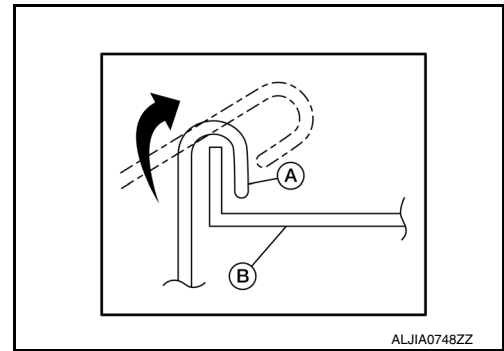

3. Separate the seat cushion trim from the seat cushion pad.
 - a. Pull seat cushion trim upward to release hook fasteners (A).
 - b. Remove hog rings and separate the seat cushion trim from the seat cushion pad.

NOTE:

Remove all pieces of hog rings and discard them.

□: Hog ring

↔: Front

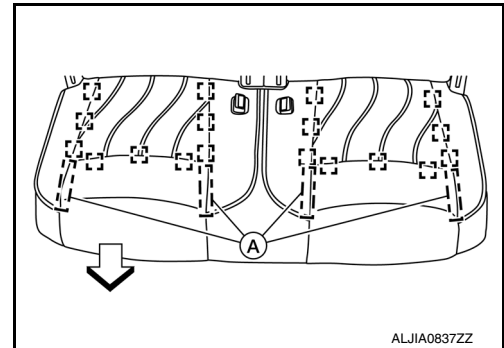

4. Remove the screw, release the metal clip and pawls, then remove the seat hinge finishers (LH/RH) from the seat frame.
5. Release the pawls and remove the seat hinge finisher (center) from the seat frame.

ASSEMBLY

Assembly is in the reverse order of disassembly.

- Install new hog rings on the seat cushion trim in original positions.
- Use only one hog ring in each designated location.
- Make sure hog rings are correctly fastened around both the seat cushion trim and seat cushion pad wires.
- Use NISSAN standard hog rings and tools to assemble.
- Make sure hook fastener is pressed into place after seat cushion trim is assembled.
- Smooth out all wrinkles during assembly.

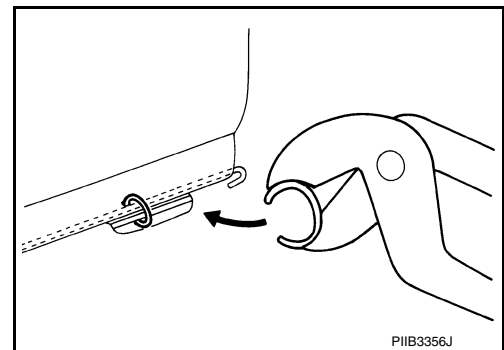

A
B
C
D
E
F
G
H
I
SE
K
L
M
N
O
P