

SECTION **STC**

STEERING CONTROL SYSTEM

A
B
C
D
E
F
STC
H
I
J
K
L
M
N
O
P

CONTENTS

PRECAUTION	3	HYDRAULIC PUMP ELECTRIC POWER STEERING SYSTEM	14
PRECAUTIONS	3	Wiring Diagram	14
Precaution for Supplemental Restraint System (SRS) "AIR BAG" and "SEAT BELT PRE-TENSIONER"	3	BASIC INSPECTION	18
Service Notice and Precautions for Hydraulic Pump Electric Power Steering System	3	DIAGNOSIS AND REPAIR WORK FLOW	18
SYSTEM DESCRIPTION	4	Work Flow	18
COMPONENT PARTS	4	Diagnostic Work Sheet	19
Component Parts Location	4	DTC/CIRCUIT DIAGNOSIS	21
Component Description	4	C1143 STEERING ANGLE SENSOR	21
Power Steering Oil Pump Assembly	5	DTC Logic	21
SYSTEM	6	Diagnosis Procedure	21
HYDRAULIC PUMP ELECTRIC POWER STEERING SYSTEM	6	C1601 BATTERY POWER SUPPLY	22
HYDRAULIC PUMP ELECTRIC POWER STEERING SYSTEM : System Description	6	DTC Logic	22
HYDRAULIC PUMP ELECTRIC POWER STEERING SYSTEM : Fail-safe	8	Diagnosis Procedure	22
HYDRAULIC PUMP ELECTRIC POWER STEERING SYSTEM : Protection Function	9	C1606 EPS MOTOR	25
DIAGNOSIS SYSTEM (POWER STEERING CONTROL MODULE)	10	DTC Logic	25
CONSULT Function	10	Diagnosis Procedure	25
ECU DIAGNOSIS INFORMATION	11	C1607, C1608 POWER STEERING CONTROL MODULE	26
POWER STEERING CONTROL MODULE	11	DTC Logic	26
Reference Value	11	Diagnosis Procedure	26
Fail-safe	12	C160A HEAT PROTECTION	27
Protection Function	12	DTC Logic	27
DTC Inspection Priority Chart	13	U1000 CAN COMM CIRCUIT	28
DTC Index	13	Description	28
WIRING DIAGRAM	14	DTC Logic	28
		Diagnosis Procedure	28
		HYDRAULIC PUMP ELECTRIC POWER STEERING WARNING LAMP	29
		Component Function Check	29
		Diagnosis Procedure	29
		SYMPTOM DIAGNOSIS	30

HYDRAULIC PUMP ELECTRIC POWER STEERING WARNING LAMP DOES NOT TURN ON	30	UNBALANCE STEERING WHEEL TURNING FORCE AND RETURN BETWEEN RIGHT AND LEFT	34
Description	30	Diagnosis Procedure	34
Diagnosis Procedure	30	UNBALANCE STEERING WHEEL TURNING FORCE (TORQUE VARIATION)	35
HYDRAULIC PUMP ELECTRIC POWER STEERING WARNING LAMP DOES NOT TURN OFF	31	Diagnosis Procedure	35
Description	31	REMOVAL AND INSTALLATION	37
Diagnosis Procedure	31	POWER STEERING CONTROL MODULE	37
STEERING WHEEL TURNING FORCE IS HEAVY OR LIGHT	32	Removal and Installation	37
Diagnosis Procedure	32		

PRECAUTIONS

< PRECAUTION >

PRECAUTION

PRECAUTIONS

Precaution for Supplemental Restraint System (SRS) "AIR BAG" and "SEAT BELT PRE-TENSIONER"

INFOID:000000011152826

The Supplemental Restraint System such as "AIR BAG" and "SEAT BELT PRE-TENSIONER", used along with a front seat belt, helps to reduce the risk or severity of injury to the driver and front passenger for certain types of collision. Information necessary to service the system safely is included in the SR and SB section of this Service Manual.

WARNING:

- To avoid rendering the SRS inoperative, which could increase the risk of personal injury or death in the event of a collision which would result in air bag inflation, all maintenance must be performed by an authorized NISSAN/INFINITI dealer.
- Improper maintenance, including incorrect removal and installation of the SRS, can lead to personal injury caused by unintentional activation of the system. For removal of Spiral Cable and Air Bag Module, see the SR section.
- Do not use electrical test equipment on any circuit related to the SRS unless instructed to in this Service Manual. SRS wiring harnesses can be identified by yellow and/or orange harnesses or harness connectors.

PRECAUTIONS WHEN USING POWER TOOLS (AIR OR ELECTRIC) AND HAMMERS

WARNING:

- When working near the Airbag Diagnosis Sensor Unit or other Airbag System sensors with the Ignition ON or engine running, DO NOT use air or electric power tools or strike near the sensor(s) with a hammer. Heavy vibration could activate the sensor(s) and deploy the air bag(s), possibly causing serious injury.
- When using air or electric power tools or hammers, always switch the Ignition OFF, disconnect the battery and wait at least three minutes before performing any service.

Service Notice and Precautions for Hydraulic Pump Electric Power Steering System

INFOID:000000011152827

- Check each tire for proper air pressure and size. Refer to [WT-66. "Tire Air Pressure"](#).
- Verify that the steering system components are genuine NISSAN parts and have been installed properly.
- Check the steering column for loose mounting bolts.
- Check the steering gear assembly for loose mounting bolts. Check the inner sockets and outer sockets for damage or wear. Inspect the boots and seals for leakage of power steering fluid.
- Verify proper wheel alignment. Refer to [FSU-5. "Inspection and Adjustment"](#).
- Check for any damage, wear, or modification to the suspension and body that would result in increased weight or an improper wheelarch height. Refer to [FSU-22. "Wheelarch Height"](#).
- Check for proper battery voltage.
- Verify that all power steering pump assembly connections are clean and fully seated.
- Verify that only genuine NISSAN E-PSF is used. Use of any power steering fluid other than genuine NISSAN E-PSF will prevent the power steering system from proper operation.
- An audible high pitch noise may be heard from the engine compartment when the steering wheel is operated, particularly at low speeds such as a parking lot maneuver. This condition is not a malfunction, rather normal system operation. Steering at low speeds or parking lot maneuvers demands higher hydraulic assistance, resulting in larger power steering pump load and increased system noise.
- The power steering pump is electrically controlled by the power steering control module.
- Before connecting or disconnecting the power steering control module harness connectors, turn ignition switch "OFF" and disconnect battery ground cable. Battery voltage is applied to power steering control module even if ignition switch is turned "OFF".

COMPONENT PARTS

< SYSTEM DESCRIPTION >

SYSTEM DESCRIPTION

COMPONENT PARTS

Component Parts Location

INFOID:000000011152828

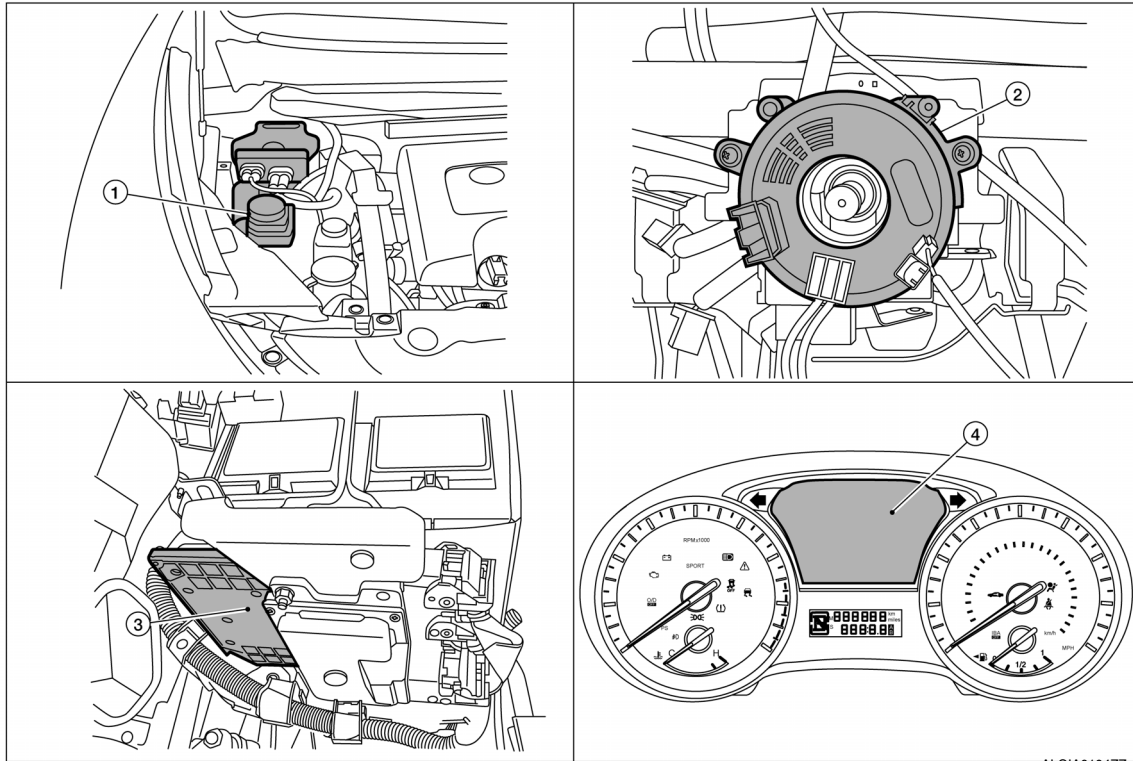

ALGIA0104ZZ

1. Power steering oil pump assembly (view from the right side of the engine compartment)
2. Steering angle sensor (view with the steering wheel removed)
3. ECM (view from the left side of the engine compartment)
4. Combination meter

Component Description

INFOID:000000011152829

Component parts	Reference
Power steering oil pump assembly	STC-5. "Power Steering Oil Pump Assembly"
Steering angle sensor	Transmits steering angle sensor signal to the power steering control module via CAN communication.
ECM	Transmits engine speed signal to the power steering control module via CAN communication.
Combination meter	Transmits vehicle speed signal to the power steering control module via CAN communication.

COMPONENT PARTS

< SYSTEM DESCRIPTION >

Power Steering Oil Pump Assembly

INFOID:000000011152830

The power steering oil pump assembly is primarily composed of the reservoir tank (1), power steering oil pump (2), power steering motor (3), and power steering control module (4).

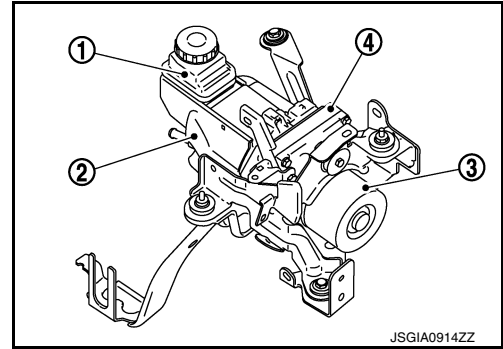

RESERVOIR TANK

Fluid is filled from the reservoir tank.

POWER STEERING OIL PUMP

The power steering oil pump is driven by the power steering motor and generates hydraulic oil pressure in the system.

POWER STEERING MOTOR

The power steering motor is controlled by the power steering control module and drives the power steering oil pump.

POWER STEERING CONTROL MODULE

By receiving steering angle sensor signal and vehicle speed signal, the power steering control module calculates hydraulic pressure of the hydraulic pump electric power steering system according to the driving conditions. The power steering control module controls the power steering motor.

A
B
C
D
E
F
STC
H
I
J
K
L
M
N
O
P

SYSTEM

< SYSTEM DESCRIPTION >

SYSTEM

HYDRAULIC PUMP ELECTRIC POWER STEERING SYSTEM

HYDRAULIC PUMP ELECTRIC POWER STEERING SYSTEM : System Description

INFOID:000000011152831

- The system is composed primarily of the power steering oil pump assembly (power steering control module, power steering motor, power steering oil pump, and reservoir tank), hydraulic pipes, and steering gear assembly.
- The power steering control module controls the speed of the power steering motor according to the vehicle speed and steering angle speed. By changing the power steering oil pump flow, the power steering control module controls the steering assist force.
- According to the power steering motor control, the system hydraulic pressure is transmitted from the power steering motor to power steering oil pump. The power steering oil pump is driven by the system hydraulic pressure.
- After engine start, the hydraulic pump electric power steering system performs control.
- When a malfunction occurs in the system, the fail-safe function stops the hydraulic pump electric power steering system (manual steering state) or restricts its operation (certain steering assist force). Refer to [STC-8, "HYDRAULIC PUMP ELECTRIC POWER STEERING SYSTEM : Fail-safe"](#).
- When the power steering function is used continuously in an extreme manner, the protective function reduces the output to the power steering motor. Refer to [STC-9, "HYDRAULIC PUMP ELECTRIC POWER STEERING SYSTEM : Protection Function"](#).

SYSTEM DIAGRAM

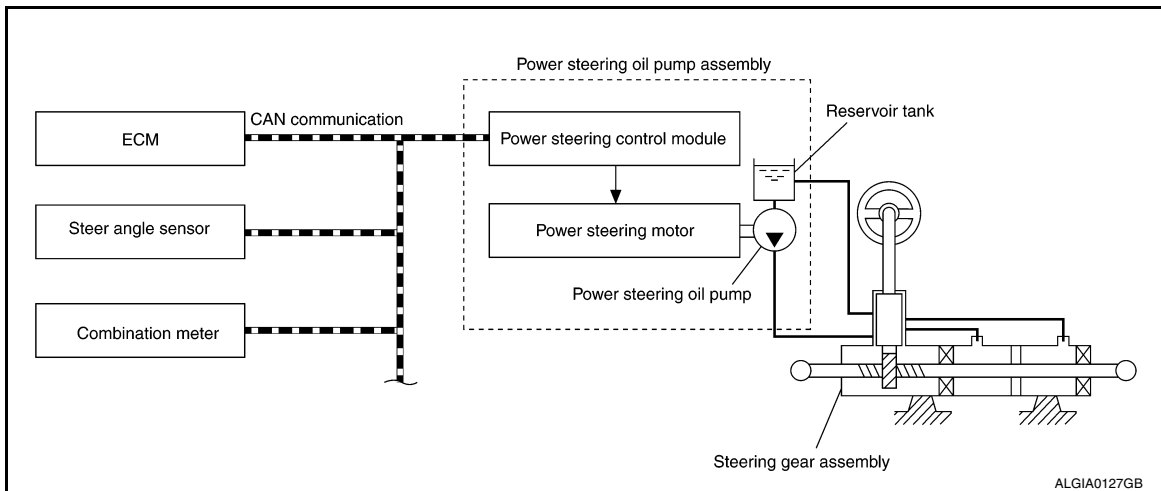

INPUT/OUTPUT SIGNAL

Communicates the signal from each control unit via CAN communication.

Control unit	Signal status
ECM	Transmits engine status signal to power steering control module via CAN communication.
Steering angle sensor	Transmits steering angle sensor signal to power steering control module via CAN communication.
Combination meter	Transmits vehicle speed signal to power steering control module via CAN communication.
	Receives hydraulic pump electric power steering warning lamp signal from power steering control module via CAN communication.

OPERATION CHARACTERISTICS

SYSTEM

< SYSTEM DESCRIPTION >

When the steering angle speed is high or the vehicle speed is low, force is generated by increasing discharge amount from the power steering oil pump and by raising system hydraulic pressure.

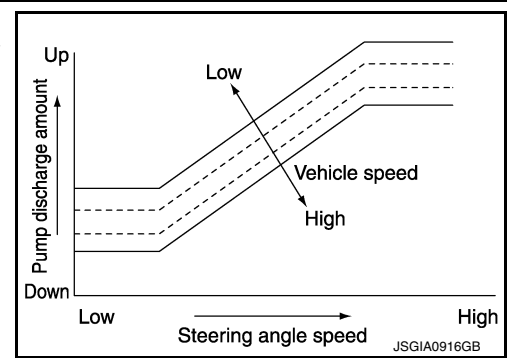

OPERATION PRINCIPLE

When Steering Wheel is in the Neutral Position

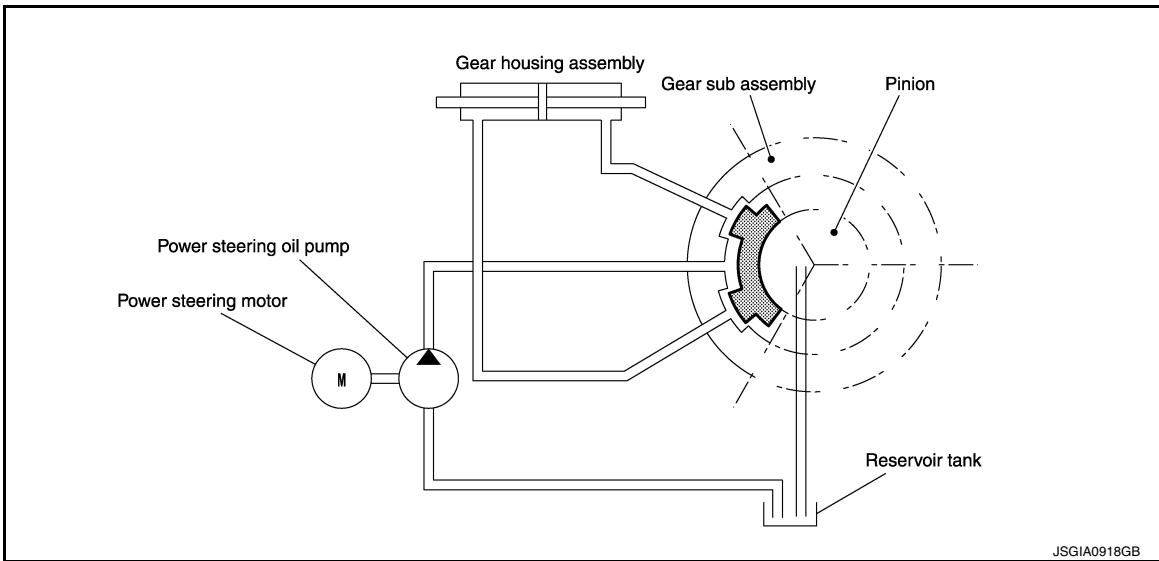

Because the hydraulic routes open at the power steering pump, gear housing right side, gear housing left side, and reservoir tank, the hydraulic pressure applied to the right side and left side of the gear housing is equal and no steering assist force is generated.

When Steering Wheel is Rotated to the Right

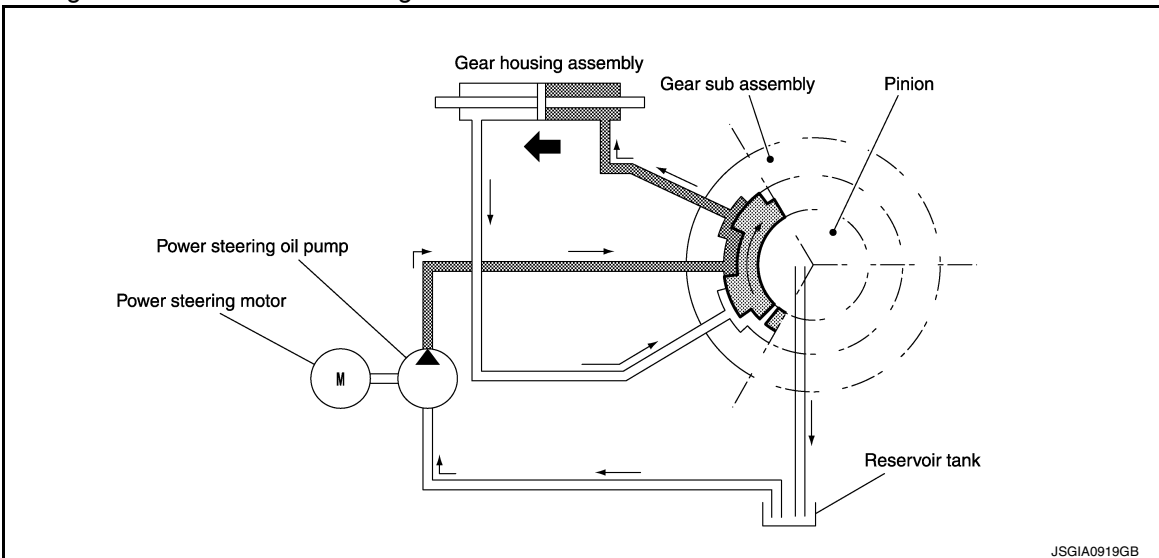

The hydraulic routes open from power steering pump to gear housing right side and from gear housing left side to reservoir tank, providing left direction assist force to the rack.

A
B
C
D
E
F
STC
H
I
J
K
L
M
N
O
P

SYSTEM

< SYSTEM DESCRIPTION >

When Steering Wheel is Rotated to the Left

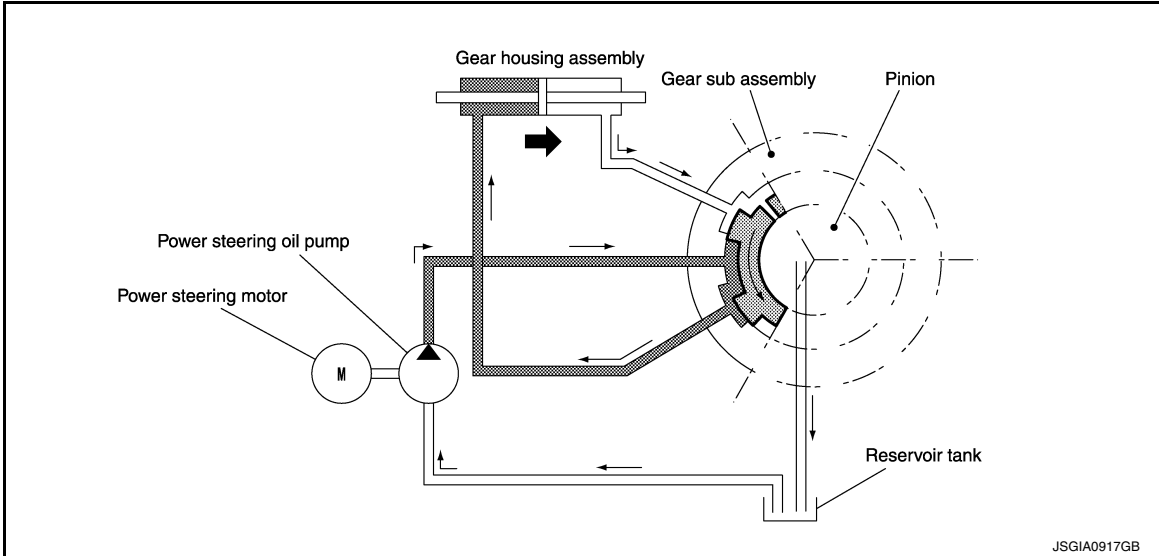

The hydraulic routes open from power steering pump to gear housing left side and from gear housing right side to reservoir tank, providing right direction assist force to the rack.

CONDITIONS FOR HYDRAULIC PUMP ELECTRIC POWER STEERING WARNING LAMP ON

- When the hydraulic pump electric power steering system is operating and steering assist force is being generated, the hydraulic pump electric power steering warning lamp is OFF.
- When the hydraulic pump electric power steering system is stopped by the fail-safe or protective function and steering assist force is not being generated, the hydraulic pump electric power steering warning lamp turns ON to inform the driver that the system is in the manual steering state.

NOTE:

When the hydraulic pump electric power steering system warning lamp turns ON according to the protection system, the cause is internal high temperature state of the hydraulic pump electric power steering system. By stopping the engine, internal temperature of the system decreases. After starting the engine, the system returns to the normal state and the hydraulic pump electric power steering system warning lamp turns OFF. (The system is not malfunctioning.) For information about the protective function, refer to [STC-9, "HYDRAULIC PUMP ELECTRIC POWER STEERING SYSTEM : Protection Function"](#).

- When the ignition switch is turned ON, this lamp turns ON for lamp check (system check). When the system is operating normally, the lamp turns OFF after the engine starts.

Condition	Hydraulic pump electric power steering warning lamp
Ignition switch ON. (Lamp check)	ON
After engine start (steering assist force is generated)	OFF
When steering assist is stopped	ON

HYDRAULIC PUMP ELECTRIC POWER STEERING SYSTEM : Fail-safe INFOID:000000011152832

When an error occurs in the hydraulic pump electric power steering system, fail-safe brings the system to a halt (manual steering) or restricted (constant steering assist level) state. When the system is in a halt state, fail-safe turns ON the hydraulic pump electric power steering warning lamp to warn the driver that the hydraulic pump electric power steering system is in the manual steering state.

DTC	Fail-safe condition
C1143	Certain steering assist force
C1601	Manual steering state
C1606	Manual steering state
C1607	Certain steering assist force

SYSTEM

< SYSTEM DESCRIPTION >

DTC	Fail-safe condition
C1608	Manual steering state
U1000	Normal control NOTE: If the cause is in a different ECU, the state changes to fixed steering assist force.

A
B
C
D
E
F
H
I
J
K
L
M
N
O
P

HYDRAULIC PUMP ELECTRIC POWER STEERING SYSTEM : Protection Function

INFOID:000000011152833

- When the steering wheel is operated repeatedly or turned all the way for a long period during parking or low speed driving, the function of the hydraulic pump electric power steering system becomes limited to prevent the system from overheating. Continued operation of the steering wheel will cause the hydraulic pump electric power steering system to stop and the hydraulic pump electric power steering system warning lamp may come ON. In this case, the steering wheel operation temporarily becomes hard. This is not a malfunction. When the engine is turned OFF (ignition switch OFF) and steering operation is stopped for a while, the temperature of the hydraulic pump electric power steering system decreases and the steering operation returns to normal after restarting the engine.
- Then, the hydraulic pump electric power steering system warning lamp turns OFF. If the system is OFF under the protection state, the hydraulic pump electric power steering system warning lamp turns ON to warn that the system is in the manual steering state. (This is not a system malfunction.) In addition, the following DTC remains to distinguish from malfunction.

DTC	vehicle condition
C160A	The system temporarily enters the manual steering state. (This is not a hydraulic pump electric power steering system malfunction.)

STC

DIAGNOSIS SYSTEM (POWER STEERING CONTROL MODULE)

< SYSTEM DESCRIPTION >

DIAGNOSIS SYSTEM (POWER STEERING CONTROL MODULE)

CONSULT Function

INFOID:0000000011152834

CAUTION:

After disconnecting the CONSULT vehicle interface (VI) from the data link connector, the ignition must be cycled OFF → ON (for at least 5 seconds) → OFF. If this step is not performed, the BCM may not go to "sleep mode", potentially causing a discharged battery and a no-start condition.

FUNCTION

CONSULT can display each diagnostic item using the diagnostic test modes shown as per the following.

Diagnostic test mode	Function
ECU identification	The part number stored in the control unit can be read.
Self Diagnostic Results	Self-diagnostic results and freeze frame data can be read and erased quickly.
Data monitor	Input/Output data in the power steering control module can be read.

ECU IDENTIFICATION

Displays the part number stored in the control unit.

SELF-DIAG RESULTS MODE

Refer to [STC-13. "DTC Index"](#).

When "CRNT" is displayed on self-diagnosis result.

- The system is presently malfunctioning.

When "PAST" is displayed on self-diagnosis result.

- System malfunction in the past is detected, but the system is presently normal.

DATA MONITOR MODE

Monitor item (Unit)	Remarks
BATTERY VOLT (V)	Displays the power supply voltage for power steering control module.
STEERING ANGLE (deg)	Displays the steering angle based on the steering angle signal transmitted by CAN communications.
STR ANG SPD (deg/s)	Displays the steering angle speed based on the steering angle signal transmitted by CAN communications.
MOTOR CURRENT (A)	Displays the current value consumed by power steering control module.
MTR REV SPD COMM (rpm)	Displays the power steering motor speed command value.
MTR REV SPD (rpm)	Displays the power steering motor speed.
C/U TEMP (°C or °F)	Displays the temperature of the power steering control module.
C/U TEMP A (°C or °F)	Displays the temperature of the power steering control module.
MTR ASSIST (%)	Displays the current percentage of the allowable assist ratio power steering motor.
ESTM VHCL SPD (km/h or mph)	Displays the vehicle speed calculated by the power steering control module.
WARNING LAMP (On/Off)	Hydraulic pump electric power steering system warning lamp control status is displayed.
ENGINE STATUS (STOP/RUN/CRANK)	Engine speed is displayed from engine condition signal with CAN communication
VHCL SPD JUDGE (OK/NG)	Displays the receiving status of the vehicle speed signal transmitted by CAN communications.

POWER STEERING CONTROL MODULE

< ECU DIAGNOSIS INFORMATION >

ECU DIAGNOSIS INFORMATION

POWER STEERING CONTROL MODULE

Reference Value

INFOID:0000000011152835

VALUES ON THE DIAGNOSIS TOOL

Monitor item	Data monitor		
	Condition	Display value	
BATTERY VOLT	Engine running	Battery voltage (V)	
STEERING ANGLE	The steering wheel is not steered.	Approx. 0.0 deg	
	The steering wheel is steered.	Displays steering angle (deg)	
STR ANG SPD	The steering wheel is not steered.	Approx. 0.0 deg/s	
	The steering wheel is steered.	Displays steering angle speed (deg/s)	
MOTOR CURRENT	Engine running	Steering wheel: Not steering (There is no steering force)	MAX approx. 10 A ^{*1}
		Steering wheel: Right or left turn	Displays consumption current of power steering control module (A)
MTR REV SPD COMM	Engine running	Steering wheel: Not steering (There is no steering force)	Shows an almost constant value (rpm)
		Steering wheel: Right or left turn	The value changes as a steering speed (rpm)
MTR REV SPD	Engine running	Steering wheel: Not steering (There is no steering force)	Shows an almost constant value (rpm) ^{*2}
		Steering wheel: Right or left turn	The value changes as a steering speed (rpm) ^{*2}
C/U TEMP	Engine running	Displays temperature of inside of power steering control module (°C or °F)	
C/U TEMP A	Engine running	Displays temperature of inside of power steering control module (°C or °F)	
MTR ASSIST	Engine running	100% ^{*3}	
ESTM VHCL SPD	Vehicle stopped	0.00 km/h or mph	
	While driving	Approximately equal to the indication on speedometer ^{*4} (inside of ±10%)	
WARNING LAMP	Hydraulic pump electric power steering warning lamp: ON	On	
	Hydraulic pump electric power steering warning lamp: OFF	Off	
ENGINE STATUS	Engine not running	STOP	
	Engine running	RUN	
	Engine cranking	CRANK	
VHCL SPD JUDGE	Vehicle speed signal can be received via CAN communication	OK	
	Vehicle speed signal cannot be received via CAN communication	NG	

*1: The value changes according to load of power steering motor.

*2: This is in close agreement with a motor speed command value. Although a quick steering operation may cause disagreement, this is not a malfunction.

*3: Usually, 100% is displayed. An excessive steering operation gradually lowers the percentage. When left standing, the percentage returns to 100%.

POWER STEERING CONTROL MODULE

< ECU DIAGNOSIS INFORMATION >

*4: This may not agree with the speedometer indication immediately after the ignition switch is turned ON. This is not a malfunction.

TERMINAL LAYOUT

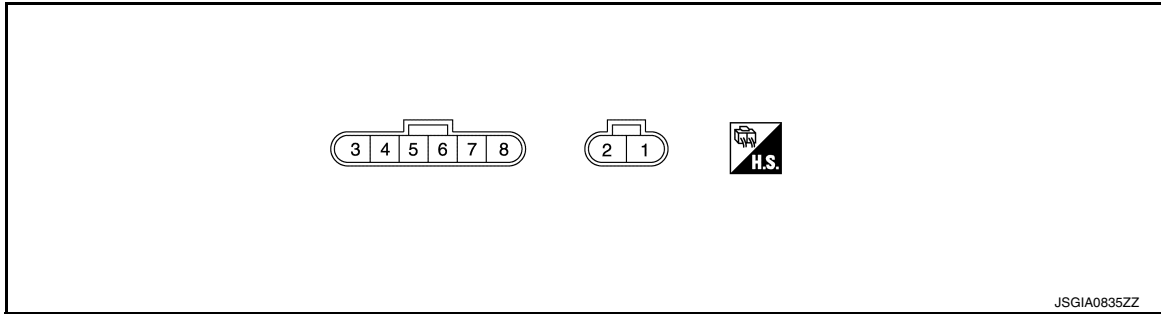

PHYSICAL VALUES

Terminal No. (Wire Color)		Description		Condition	Value (Approx.)
+	-	Signal name	Input/Output		
1 (W)	Ground	Battery power supply	Input	Always	Battery voltage
2 (W)	Ground	Ground	—	Always	0 V
5 (BR)	Ground	Ignition power supply	Input	Ignition switch: ON	Battery voltage
				Ignition switch: OFF	0 V
7 (P)	—	CAN-L	Input/Output	—	—
8 (L)	—	CAN-H	Input/Output	—	—

Fail-safe

INFOID:000000011152836

When an error occurs in the hydraulic pump electric power steering system, fail-safe brings the system to a halt (manual steering) or restricted (constant steering assist level) state. When the system is in a halt state, fail-safe turns ON the hydraulic pump electric power steering warning lamp to warn the driver that the hydraulic pump electric power steering system is in the manual steering state.

DTC	Fail-safe condition
C1143	Certain steering assist force
C1601	Manual steering state
C1606	Manual steering state
C1607	Certain steering assist force
C1608	Manual steering state
U1000	Normal control NOTE: If the cause is in a different ECU, the state changes to fixed steering assist force.

Protection Function

INFOID:000000011152837

- When the steering wheel is operated repeatedly or turned all the way for a long period during parking or low speed driving, the function of the hydraulic pump electric power steering system becomes limited to prevent the system from overheating. If the steering wheel is operated further more, the hydraulic pump electric power steering system stops and the hydraulic pump electric power steering system warning lamp may be turned ON. In this case, the steering wheel operation temporarily becomes hard. This is not a malfunction. When the engine is turned OFF (ignition switch OFF) and steering operation is stopped for a while, the temperature of the hydraulic pump electric power steering system decreases and the steering operation returns to normal after restarting the engine.

POWER STEERING CONTROL MODULE

< ECU DIAGNOSIS INFORMATION >

- Then, the hydraulic pump electric power steering system warning lamp turns OFF. If the system is OFF under the protection state, the hydraulic pump electric power steering system warning lamp turns ON to warn that the system is in the manual steering state. (This is not a system malfunction.) In addition, the following DTC remains to distinguish from malfunction.

DTC	vehicle condition
C160A	The system temporarily enters the manual steering state. (This is not a hydraulic pump electric power steering system malfunction.)

DTC Inspection Priority Chart

INFOID:000000011152838

When multiple DTCs are detected simultaneously, check one by one depending on the following priority list.

Priority	Priority order item (DTC)
1	<ul style="list-style-type: none"> C1601 BATTERY VOLT C1606 EPS MOTOR C1608 CONTROL UNIT
2	<ul style="list-style-type: none"> C1607 EEPROM
3	<ul style="list-style-type: none"> C160A HEAT PROTECTION
4	<ul style="list-style-type: none"> C1143 ST ANG SEN CIRCUIT U1000 CAN COMM CIRCUIT

STC

DTC Index

INFOID:000000011152839

DTC	Items (CONSULT screen terms)	Reference
C1143	ST ANG SEN CIRCUIT	STC-21, "DTC Logic"
C1601	BATTERY VOLT	STC-22, "DTC Logic"
C1606	EPS MOTOR	STC-25, "DTC Logic"
C1607	EEPROM	STC-26, "DTC Logic"
C1608	CONTROL UNIT	STC-26, "DTC Logic"
C160A	HEAT PROTECTION	STC-27, "DTC Logic"
U1000	CAN COMM CIRCUIT	STC-28, "DTC Logic"

NOTE:

If two or more DTCs are detected, refer to [STC-13, "DTC Inspection Priority Chart"](#).

HYDRAULIC PUMP ELECTRIC POWER STEERING SYSTEM

< WIRING DIAGRAM >

WIRING DIAGRAM

HYDRAULIC PUMP ELECTRIC POWER STEERING SYSTEM

Wiring Diagram

INFOID:000000011152840

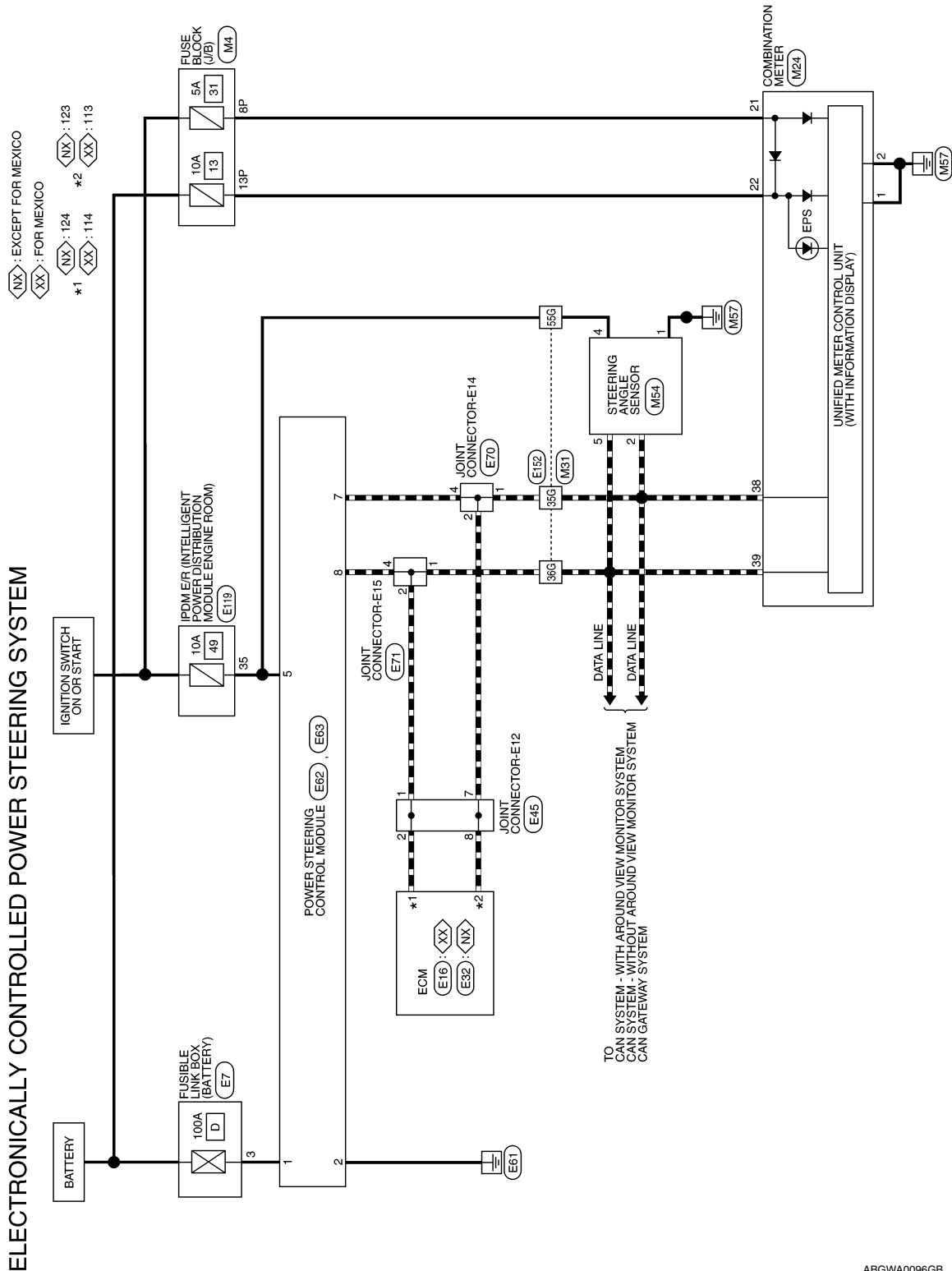

ABGWA0096GB

HYDRAULIC PUMP ELECTRIC POWER STEERING SYSTEM

< WIRING DIAGRAM >

ELECTRONICALLY CONTROLLED POWER STEERING SYSTEM CONNECTORS

Connector No.	M4
Connector Name	FUSE BLOCK (J/B)
Connector Color	WHITE



Connector No.	M24
Connector Name	COMBINATION METER
Connector Color	WHITE



Terminal No.	Color of Wire	Signal Name
22	W	BAT
38	P	CAN-L
39	L	CAN-H

Terminal No.	Color of Wire	Signal Name
8P	BG	-
13P	W	-

Terminal No.	Color of Wire	Signal Name
1	B	GND1
2	B	GND2
21	BG	IGN

Connector No.	M31
Connector Name	WIRE TO WIRE
Connector Color	WHITE

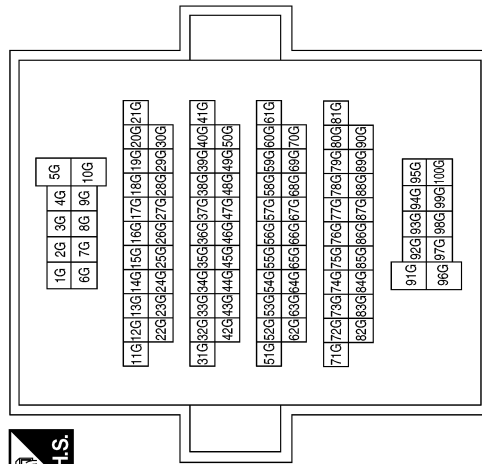

Connector No.	M54
Connector Name	STEERING ANGLE SENSOR
Connector Color	WHITE

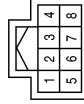

Terminal No.	Color of Wire	Signal Name
1	GR	-
2	P	-
4	G	-
5	L	-

ABGIA0145GB

A
B
C
D
E
F
G
H
I
J
K
L
M
N
O
P

STC

HYDRAULIC PUMP ELECTRIC POWER STEERING SYSTEM

< WIRING DIAGRAM >

Connector No.	E32
Connector Name	ECM (EXCEPT FOR MEXICO)
Connector Color	BLACK

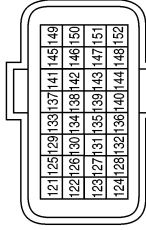

Terminal No.	Color of Wire	Signal Name
123	P	CAN-L
124	L	CAN-H

Connector No.	E16
Connector Name	ECM (FOR MEXICO)
Connector Color	GRAY

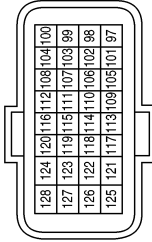

Terminal No.	Color of Wire	Signal Name
113	P	CAN-L
114	L	CAN-H

Connector No.	E7
Connector Name	FUSIBLE LINK BOX (BATTERY)
Connector Color	GRAY



Terminal No.	Color of Wire	Signal Name
3	W	-

Connector No.	E63
Connector Name	POWER STEERING CONTROL MODULE
Connector Color	BLACK



Terminal No.	Color of Wire	Signal Name
1	W	+B
2	W	GND

Connector No.	E62
Connector Name	POWER STEERING CONTROL MODULE
Connector Color	BLACK



Terminal No.	Color of Wire	Signal Name
3	-	-
4	-	-
5	BR	VIGN
6	-	-
7	P	CAN-L
8	L	CAN-H

Connector No.	E45
Connector Name	JOINT CONNECTOR-E12
Connector Color	BLUE

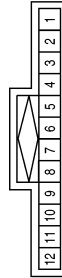

Terminal No.	Color of Wire	Signal Name
1	L	-
2	L	-
7	P	-
8	P	-

ABGIA0146GB

HYDRAULIC PUMP ELECTRIC POWER STEERING SYSTEM

< WIRING DIAGRAM >

Connector No.	E119
Connector Name	IPDM E/R (INTELLIGENT POWER DISTRIBUTION MODULE ENGINE ROOM)
Connector Color	WHITE

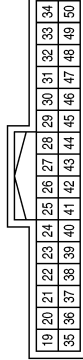
Terminal No.	Color of Wire	Signal Name
35	BR	ABS ECU

Connector No.	E71
Connector Name	JOINT CONNECTOR-E15
Connector Color	BLACK



Terminal No.	Color of Wire	Signal Name
1	L	-
2	L	-
4	L	-

Connector No.	E70
Connector Name	JOINT CONNECTOR-E14
Connector Color	BLACK



Terminal No.	Color of Wire	Signal Name
1	P	-
2	P	-
4	P	-

Terminal No.	Color of Wire	Signal Name
35G	P	-
36G	L	-
55G	BR	-

Connector No.	E152
Connector Name	WIRE TO WIRE
Connector Color	WHITE

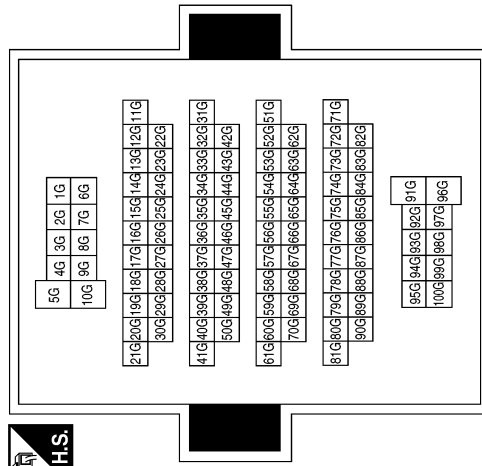
ABGIA0147GB

A
B
C
D
E
F
STC
H
I
J
K
L
M
N
O
P

DIAGNOSIS AND REPAIR WORK FLOW

< BASIC INSPECTION >

BASIC INSPECTION

DIAGNOSIS AND REPAIR WORK FLOW

Work Flow

INFOID:000000011152841

DETAILED FLOW

1. INTERVIEW FROM THE CUSTOMER

Clarify customer complaints before inspection. First of all, perform an interview utilizing [STC-19, "Diagnostic Work Sheet"](#) and reproduce symptoms to understand them fully. Ask customer about his/her complaints carefully. Check symptoms by driving vehicle with customer, if necessary.

CAUTION:

Customers are not professional. Never make assumptions like "maybe the customer means that..." or "maybe the customer mentioned this symptom".

>> GO TO 2.

2. CHECK SYMPTOM

Reproduce the symptom that is indicated by the customer, based on the information from the customer obtained by interview. Also check that the symptom is not caused by protection function. Refer to [STC-12, "Protection Function"](#).

CAUTION:

When the symptom is caused by normal operation, fully inspect each portion and obtain the understanding of customer that the symptom is not caused by a malfunction.

>> GO TO 3.

3. CHECK VEHICLE CONDITION

With CONSULT

1. Turn ignition switch ON.
2. Check "C/U TEMP" and "C/U TEMP A" in "DATA MONITOR" of "EPS".

Monitor item	Values
C/U TEMP	90°C (194°F) or less
C/U TEMP A	90°C (194°F) or less

Is the inspection result normal?

YES >> GO TO 4.

NO >> Wait with the ignition switch OFF until the data monitor indication becomes 90 °C (194 °F) or less. Go to 4 after the temperature drops to 90 °C (194 °F) or less.

4. PERFORM SELF-DIAGNOSIS

With CONSULT

Perform self-diagnosis.

Is any DTC detected?

YES >> Record or print DTC and freeze frame data (FFD). GO TO 5.

NO >> GO TO 7.

5. RECHECK SYMPTOM

With CONSULT

1. Erase self-diagnostic results for "EPS".
2. Perform DTC confirmation procedures for the malfunctioning system.

NOTE:

If some DTCs are detected at the same time, determine the order for performing the diagnosis based on [STC-13, "DTC Inspection Priority Chart"](#).

Is any DTC detected?

DIAGNOSIS AND REPAIR WORK FLOW

< BASIC INSPECTION >

Interview sheet					
Customer name	MR/MS	Registration number		Initial year registration	
		Vehicle type		VIN	
Storage date		Engine		Mileage	km (Mile)
Operation conditions, etc.	<input type="checkbox"/> Irrelevant <input type="checkbox"/> When engine starts <input type="checkbox"/> During idling <input type="checkbox"/> During driving <input type="checkbox"/> During acceleration <input type="checkbox"/> At constant speed driving <input type="checkbox"/> During deceleration <input type="checkbox"/> During cornering (right curve or left curve) <input type="checkbox"/> During steering				
Other conditions					
Memo					

C1143 STEERING ANGLE SENSOR

< DTC/CIRCUIT DIAGNOSIS >

DTC/CIRCUIT DIAGNOSIS

C1143 STEERING ANGLE SENSOR

DTC Logic

INFOID:000000011152843

DTC DETECTION LOGIC

DTC	Display item	Malfunction detected condition	Possible cause
C1143	ST ANG SEN CIRCUIT	When a malfunction is detected in steering angle sensor.	<ul style="list-style-type: none">• Harness or connector• Steering angle sensor• Power steering control module

DTC CONFIRMATION PROCEDURE

1. PRECONDITIONING

If "DTC CONFIRMATION PROCEDURE" has been previously conducted, always turn ignition switch OFF and wait at least 10 seconds before conducting the next test.

>> GO TO 2.

2. DTC REPRODUCTION PROCEDURE

With CONSULT

1. Turn the ignition switch OFF to ON.
2. Perform "EPS" self-diagnosis.

Is DTC "C1143" detected?

- YES >> Proceed to diagnosis procedure. Refer to [STC-21, "Diagnosis Procedure"](#).
NO >> Inspection End.

Diagnosis Procedure

INFOID:000000011152844

1. CHECK STEERING ANGLE SENSOR CIRCUIT

Check steering angle sensor circuit. Refer to [BRC-218, "Diagnosis Procedure"](#).

Is the inspection result normal?

- YES >> GO TO 2.
NO >> Repair or replace malfunctioning component.

2. CHECK TERMINALS AND HARNESS CONNECTORS

Check the power steering control module pin terminals for damage or loose connection with harness connector.

Is the inspection result normal?

- YES >> Power steering control module is malfunctioning. Replace power steering oil pump assembly. Refer to [STC-37, "Removal and Installation"](#).
NO >> Repair or replace malfunctioning component.

C1601 BATTERY POWER SUPPLY

< DTC/CIRCUIT DIAGNOSIS >

C1601 BATTERY POWER SUPPLY

DTC Logic

INFOID:000000011152845

DTC DETECTION LOGIC

DTC	Display item	Malfunction detected condition	Possible cause
C1601	BATTERY VOLT	When a power supply voltage to the power steering control module is maintained at 18.5 V or more or at less than 8.5 V continuously for 0.5 seconds or more.	<ul style="list-style-type: none">• Harness or connector• Power steering control module• Fuse• Battery power supply circuit• Battery

DTC CONFIRMATION PROCEDURE

1. PRECONDITIONING

If "DTC CONFIRMATION PROCEDURE" has been previously conducted, always turn ignition switch OFF and wait at least 10 seconds before conducting the next test.

>> GO TO 2.

2. DTC REPRODUCTION PROCEDURE

Ⓟ With CONSULT

1. Turn the ignition switch OFF to ON.
2. Perform "EPS" self-diagnosis.

Is DTC "C1601" detected?

- YES >> Proceed to diagnosis procedure. Refer to [STC-22. "Diagnosis Procedure"](#).
NO >> Inspection End.

Diagnosis Procedure

INFOID:000000011152846

Regarding Wiring Diagram information, refer to [STC-14. "Wiring Diagram"](#).

1. CHECK POWER STEERING CONTROL MODULE GROUND CIRCUIT

1. Turn ignition switch OFF.
2. Disconnect power steering control module harness connector.
3. Check continuity between power steering control module harness connector terminal and ground.

Power steering control module		—	Continuity
Connector	Terminal		
E63	2	Ground	Yes

Is the inspection result normal?

- YES >> GO TO 2.
NO >> Repair open circuit or short to ground or short to power in harness or connectors, and repair or replace the malfunctioning component.

2. CHECK POWER STEERING CONTROL MODULE POWER SUPPLY CIRCUIT (1)

1. Check voltage between power steering control module harness connector terminals and ground.

Power steering control module		—	Voltage (Approx.)
Connector	Terminal		
E63	1	Ground	Battery voltage

C1601 BATTERY POWER SUPPLY

< DTC/CIRCUIT DIAGNOSIS >

2. Turn ignition switch ON.
CAUTION:
Never start the engine.
3. Check voltage between power steering control module harness connector terminals and ground.

Power steering control module		—	Voltage (Approx.)
Connector	Terminal		
E63	1	Ground	Battery voltage

Is the inspection result normal?

- YES >> GO TO 4.
 NO >> GO TO 3.

3.CHECK POWER STEERING CONTROL MODULE POWER SUPPLY CIRCUIT (2)

1. Turn ignition switch OFF.
2. Check the 100A fusible link (#D).
3. Disconnect battery terminal with fusible link harness connector.
4. Check continuity between power steering control module harness connector terminal and battery terminal with fusible link harness connector terminal.

Power steering control module		Battery terminal with fusible link		Continuity
Connector	Terminal	Connector	Terminal	
E63	1	E7	3	Yes

5. Check continuity between power steering control module harness connector terminal and ground.

Power steering control module		—	Continuity
Connector	Terminal		
E63	1	Ground	No

Is the inspection result normal?

- YES >> Perform the trouble diagnosis for battery power supply circuit. Refer to [PG-16. "Wiring Diagram - BATTERY POWER SUPPLY -"](#).
 NO >> Repair or replace the malfunctioning component.

4.CHECK POWER STEERING CONTROL MODULE POWER SUPPLY CIRCUIT (3)

1. Check voltage between power steering control module harness connector terminals and ground.

Power steering control module		—	Voltage (Approx.)
Connector	Terminal		
E62	5	Ground	0 V

2. Turn ignition switch ON.
CAUTION:
Never start the engine.
3. Check voltage between power steering control module harness connector terminals and ground.

Power steering control module		—	Voltage (Approx.)
Connector	Terminal		
E62	5	Ground	Battery voltage

Is the inspection result normal?

- YES >> GO TO 6.
 NO >> GO TO 5.

5.CHECK POWER STEERING CONTROL MODULE POWER SUPPLY CIRCUIT (4)

1. Turn ignition switch OFF.

A
B
C
D
E
F
H
I
J
K
L
M
N
O
P

STC

C1601 BATTERY POWER SUPPLY

< DTC/CIRCUIT DIAGNOSIS >

2. Check the 10A fuse No. 49 in the IPDM E/R.
3. Disconnect IPDM E/R harness connector E119.
4. Check continuity between power steering control module harness connector terminal and IPDM E/R harness connector terminal.

Power steering control module		IPDM E/R		Continuity
Connector	Terminal	Connector	Terminal	
E62	5	E119	35	Yes

5. Check continuity between power steering control module harness connector terminal and ground.

Power steering control module		—	Continuity
Connector	Terminal		
E62	5	Ground	No

Is the inspection result normal?

- YES >> Perform the trouble diagnosis for ignition power supply circuit. Refer to [PG-29, "Wiring Diagram - IGNITION POWER SUPPLY -"](#).
- NO >> Repair or replace the malfunctioning component.

6. CHECK TERMINALS AND HARNESS CONNECTORS

Check the power steering control module pin terminals for damage or loose connection with harness connector.

Is the inspection result normal?

- YES >> Power steering control module is malfunctioning. Replace steering oil pump assembly. Refer to [STC-37, "Removal and Installation"](#).
- NO >> Repair or replace the malfunctioning component.

C1606 EPS MOTOR

< DTC/CIRCUIT DIAGNOSIS >

C1606 EPS MOTOR

DTC Logic

INFOID:0000000011152847

DTC DETECTION LOGIC

DTC	Display item	Malfunction detected condition	Possible cause
C1606	EPS MOTOR	When the motor driver malfunction of power steering control module or power steering control module motor driver malfunction is detected.	<ul style="list-style-type: none">• Harness or connector• Power steering control motor• Power steering control module

DTC CONFIRMATION PROCEDURE

1. PRECONDITIONING

If "DTC CONFIRMATION PROCEDURE" has been previously conducted, always turn ignition switch OFF and wait at least 10 seconds before conducting the next test.

>> GO TO 2.

2. DTC REPRODUCTION PROCEDURE

With CONSULT

1. Turn the ignition switch OFF to ON.
2. Perform "EPS" self-diagnosis.

Is DTC "C1606" detected?

- YES >> Proceed to diagnosis procedure. Refer to [STC-25, "Diagnosis Procedure"](#).
NO >> Inspection End.

Diagnosis Procedure

INFOID:0000000011152848

1. PERFORM SELF-DIAGNOSIS

With CONSULT

1. Turn the ignition switch OFF to ON.
2. Erase self-diagnostic results for "EPS".
3. Turn the ignition switch OFF and wait for at least 10 seconds.
4. Perform self-diagnosis for "EPS".

Is DTC "C1606" detected?

- YES >> Power steering motor is malfunctioning. Replace power steering oil pump assembly. Refer to [STC-37, "Removal and Installation"](#).
NO >> Check pin terminal and connection of each harness connector for malfunctioning conditions.

C1607, C1608 POWER STEERING CONTROL MODULE

< DTC/CIRCUIT DIAGNOSIS >

C1607, C1608 POWER STEERING CONTROL MODULE

DTC Logic

INFOID:000000011152849

DTC DETECTION LOGIC

DTC	Display item	Malfunction detected condition	Possible cause
C1607	EEPROM	When the memory (EEPROM) system malfunction is detected in power steering control module.	Power steering control module
C1608	CONTROL UNIT	When the internal malfunction is detected in power steering control module.	

DTC CONFIRMATION PROCEDURE

1. PRECONDITIONING

If "DTC CONFIRMATION PROCEDURE" has been previously conducted, always turn ignition switch OFF and wait at least 10 seconds before conducting the next test.

>> GO TO 2.

2. DTC REPRODUCTION PROCEDURE

With CONSULT

1. Turn the ignition switch OFF to ON.
2. Perform "EPS" self-diagnosis.

Is DTC "C1607" or "C1608" detected?

- YES >> Proceed to diagnosis procedure. Refer to [STC-26, "Diagnosis Procedure"](#).
NO >> Inspection End.

Diagnosis Procedure

INFOID:000000011152850

1. PERFORM SELF-DIAGNOSIS

With CONSULT

1. Turn the ignition switch OFF to ON.
2. Erase self-diagnostic results for "EPS".
3. Turn the ignition switch OFF and wait for at least 10 seconds.
4. Perform self-diagnosis for "EPS".

Is DTC "C1607" or "C1608" detected?

- YES >> Power steering control module is malfunctioning. Replace power steering oil pump assembly.
Refer to [STC-37, "Removal and Installation"](#).
NO >> Check pin terminal and connection of each harness connector for malfunctioning conditions.

C160A HEAT PROTECTION

< DTC/CIRCUIT DIAGNOSIS >

C160A HEAT PROTECTION

DTC Logic

INFOID:0000000011152851

DTC DETECTION LOGIC

DTC	Display item	Malfunction detected condition	Possible cause
C160A	HEAT PROTECTION	<p>When the steering wheel is operated excessively and the interior temperature of the power steering system reaches 118°C (244.4°F) or more. (Protection function)</p> <p>NOTE: Although the hydraulic pump electric power steering system warning lamp turns ON, this is not a system malfunction. The state returns to normal after stopping steering operation and waiting until the system interior temperature drops to 90°C (194°F) or less.</p>	The protection of the hydraulic pump electric power steering system

DTC CONFIRMATION PROCEDURE

1. PRECONDITIONING

If "DTC CONFIRMATION PROCEDURE" has been previously conducted, always turn ignition switch OFF and wait at least 10 seconds before conducting the next test.

>> GO TO 2.

2. DTC REPRODUCTION PROCEDURE

With CONSULT

1. Turn the ignition switch OFF to ON.
2. Perform "EPS" self-diagnosis.

Is DTC "C160A" detected?

- YES >> Go to [STC-18. "Work Flow"](#).
- NO >> Inspection End.

U1000 CAN COMM CIRCUIT

< DTC/CIRCUIT DIAGNOSIS >

U1000 CAN COMM CIRCUIT

Description

INFOID:0000000011152852

CAN (Controller Area Network) is a serial communication line for real time application. It is an on-vehicle multiplex communication line with high data communication speed and excellent error detection ability. Many electronic control units are equipped onto a vehicle, and each control unit shares information and links with other control units during operation (not independent). In CAN communication, control units are connected with 2 communication lines (CAN-H line, CAN-L line) allowing a high rate of information transmission with less wiring. Each control unit communicate data but selectively reads required data only.

DTC Logic

INFOID:0000000011152853

DTC DETECTION LOGIC

DTC	Display item	Malfunction detected condition	Possible cause
U1000	CAN COMM CIRCUIT	Power steering control module is not transmitting/receiving CAN communication signal for 2 seconds or more.	CAN communication error

DTC CONFIRMATION PROCEDURE

1. PRECONDITIONING

If "DTC CONFIRMATION PROCEDURE" has been previously conducted, always turn ignition switch OFF and wait at least 10 seconds before conducting the next test.

>> GO TO 2.

2. DTC REPRODUCTION PROCEDURE

With CONSULT

1. Turn the ignition switch OFF to ON.
2. Perform "EPS" self-diagnosis.

Is DTC "U1000" detected?

YES >> Go to [STC-28, "Diagnosis Procedure"](#).

NO >> Inspection End.

Diagnosis Procedure

INFOID:0000000011152854

Proceed to [LAN-21, "Trouble Diagnosis Flow Chart"](#).

HYDRAULIC PUMP ELECTRIC POWER STEERING WARNING LAMP

< DTC/CIRCUIT DIAGNOSIS >

HYDRAULIC PUMP ELECTRIC POWER STEERING WARNING LAMP

Component Function Check

INFOID:0000000011152855

1. CHECK THE ILLUMINATION OF THE HYDRAULIC PUMP ELECTRIC POWER STEERING WARNING LAMP

Check that the hydraulic pump electric power steering warning lamp turns ON when ignition switch turns ON. Then, hydraulic pump electric power steering warning lamp turns OFF after the engine is started.

Is the inspection result normal?

YES >> Inspection End.

NO >> Perform trouble diagnosis. Refer to [STC-29, "Diagnosis Procedure"](#).

Diagnosis Procedure

INFOID:0000000011152856

1. PERFORM SELF-DIAGNOSIS

With CONSULT

1. Turn the ignition switch OFF to ON.

2. Perform "EPS" self-diagnosis.

Is any DTC detected?

YES >> Check the DTC. Refer to [STC-13, "DTC Index"](#).

NO >> GO TO 2.

2. CHECK HYDRAULIC PUMP ELECTRIC POWER STEERING WARNING LAMP SIGNAL

With CONSULT

1. Turn the ignition switch ON.

2. Select "WARNING LAMP" in "DATA MONITOR" of "EPS".

3. Check that the item in "DATA MONITOR" is "On".

CAUTION:

Engine should not be running for step 3.

4. Start the engine.

CAUTION:

Never drive the vehicle during the test.

5. Check that the item in "DATA MONITOR" is "Off".

Is the inspection result normal?

YES >> Perform the trouble diagnosis for combination meter power supply circuit. Refer to [MWI-61, "COMBINATION METER : Diagnosis Procedure"](#).

NO >> GO TO 3.

3. CHECK TERMINALS AND HARNESS CONNECTORS

Check the power steering control module pin terminals for damage or loose connection with harness connector.

Is the inspection result normal?

YES >> Power steering control module is malfunctioning. Replace power steering oil pump assembly. Refer to [STC-37, "Removal and Installation"](#).

NO >> Repair or replace the malfunctioning component.

HYDRAULIC PUMP ELECTRIC POWER STEERING WARNING LAMP DOES NOT TURN ON

< SYMPTOM DIAGNOSIS >

SYMPTOM DIAGNOSIS

HYDRAULIC PUMP ELECTRIC POWER STEERING WARNING LAMP DOES NOT TURN ON

Description

INFOID:0000000011152857

The hydraulic pump electric power steering warning lamp does not illuminate when the ignition switch is turned ON (lamp check).

Diagnosis Procedure

INFOID:0000000011152858

1. CHECK THE HYDRAULIC PUMP ELECTRIC POWER STEERING WARNING LAMP

Perform trouble diagnosis for the hydraulic pump electric power steering warning lamp system. Refer to [STC-29. "Diagnosis Procedure"](#).

Is the inspection result normal?

- YES >> Check that the pin terminals and the connection of each connector are normal.
- NO >> Repair or replace the malfunctioning components.

HYDRAULIC PUMP ELECTRIC POWER STEERING WARNING LAMP DOES NOT TURN OFF

< SYMPTOM DIAGNOSIS >

HYDRAULIC PUMP ELECTRIC POWER STEERING WARNING LAMP DOES NOT TURN OFF

Description

INFOID:000000011152859

Hydraulic pump electric power steering warning lamp does not turn OFF several seconds after engine started

Diagnosis Procedure

INFOID:000000011152860

1.PERFORM SELF-DIAGNOSIS

With CONSULT

Perform "EPS" self-diagnosis.

Is any DTC detected?

YES >> Check the DTC. Refer to [STC-13, "DTC Index"](#).

NO >> GO TO 2.

2.CHECK HYDRAULIC PUMP ELECTRIC POWER STEERING WARNING LAMP

Perform the trouble diagnosis of hydraulic pump electric power steering warning lamp. Refer to [STC-29, "Diagnosis Procedure"](#).

Is the inspection result normal?

YES >> GO TO 3.

NO >> Repair or replace the malfunctioning components.

3.POWER STEERING CONTROL MODULE POWER SUPPLY AND GROUND CIRCUIT

Perform the trouble diagnosis of power steering control module power supply and ground. Refer to [STC-22, "Diagnosis Procedure"](#).

Is the inspection result normal?

YES >> Check that the pin terminals and the connection of each connector are normal.

NO >> Repair or replace the malfunctioning components.

A
B
C
D
E
F
H
I
J
K
L
M
N
O
P

STC

STEERING WHEEL TURNING FORCE IS HEAVY OR LIGHT

< SYMPTOM DIAGNOSIS >

STEERING WHEEL TURNING FORCE IS HEAVY OR LIGHT

Diagnosis Procedure

INFOID:0000000011152861

1. PERFORM SELF-DIAGNOSIS

With CONSULT

Perform "EPS" self-diagnosis.

Is a malfunctioning system displayed?

- YES >> Check malfunctioning system. Refer to [STC-13. "DTC Index"](#).
- NO >> GO TO 2.

2. CHECK THE POWER STEERING CONTROL MODULE SIGNAL (1)

With CONSULT

1. Start the engine.

CAUTION:

Never drive the vehicle.

- 2. Turn the steering wheel until it stops.
- 3. Select "MTR ASSIST" in "DATA MONITOR" of "EPS".

Is the display value "100%"?

- YES >> GO TO 4.
- NO >> GO TO 3.

3. CHECK THE POWER STEERING CONTROL MODULE SIGNAL (2)

With CONSULT

- 1. Select "C/U TEMP" and "C/U TEMP A" in "DATA MONITOR" of "EPS".
- 2. Stop the system until the DATA MONITOR display value drops to "90°C (194°F)" or less.
- 3. Check whether symptom continues.

Did symptom continue?

- YES >> GO TO 4.
- NO >> This occurs because the protection function lowers the assist force. It is not a system malfunction.
Inspection End.

4. CHECK THE POWER STEERING CONTROL MODULE SIGNAL (3)

With CONSULT

- 1. Turn the steering wheel to the straight-ahead position. (There is no steering force)
- 2. Select "BATTERY VOLT" in "DATA MONITOR" of "EPS".

Is the display value "10.5 V" or more?

- YES >> GO TO 5.
- NO >> Check the battery power system. Refer to [STC-22. "Diagnosis Procedure"](#).

5. CHECK THE POWER STEERING CONTROL MODULE SIGNAL (4)

With CONSULT

Select "ESTM VHCL SPD" in "DATA MONITOR" of "EPS".

Monitor item	Test condition	Display value
ESTM VHCL SPD	When stopped	0.00 km/h or mph
	While driving	Approximately equal to the indication on speedometer* (Inside of $\pm 10\%$)

*: This may not agree with the speedometer indication immediately after the ignition switch is turned ON. This is not a malfunction.

Is the check result normal?

- YES >> GO TO 6.
- NO >> Check the combination meter, ABS actuator and electric unit (control unit). Refer to [MWI-18. "CONSULT Function \(METER/M&A\)"](#) and [STC-10. "CONSULT Function"](#).

STEERING WHEEL TURNING FORCE IS HEAVY OR LIGHT

< SYMPTOM DIAGNOSIS >

6. CHECK THE POWER STEERING CONTROL MODULE SIGNAL (5)

With CONSULT

Select "STR ANG SPD" in "DATA MONITOR" of "EPS".

Monitor item	Test condition	Display value
STR ANG SPD	The steering wheel is not steered.	Approx. 0.0 deg/s
	The steering wheel is steered.	Displays steering angle speed (deg/s)

Is the check result normal?

YES >> GO TO 7.

NO >> Check the steering angle sensor. Refer to [STC-21, "Diagnosis Procedure"](#).

7. CHECK THE POWER STEERING CONTROL MODULE SIGNAL (6)

With CONSULT

Select "ENGINE STATUS" in "DATA MONITOR" of "EPS".

Is the display value "RUN"?

YES >> GO TO 8.

NO >> Check the ECM. Refer to [EC-72, "CONSULT Function"](#) (USA and Canada) or [EC-581, "CONSULT Function"](#) (Mexico).

8. CHECK THE STEERING FORCE

Check the steering force. Refer to [ST-19, "Inspection"](#).

Is the check result normal?

YES >> Inspection End.

NO >> It is possible that there is a mechanical malfunction. Check the steering system.

A
B
C
D
E
F
STC
H
I
J
K
L
M
N
O
P

UNBALANCE STEERING WHEEL TURNING FORCE AND RETURN BETWEEN RIGHT AND LEFT

< SYMPTOM DIAGNOSIS >

UNBALANCE STEERING WHEEL TURNING FORCE AND RETURN BETWEEN RIGHT AND LEFT

Diagnosis Procedure

INFOID:000000011152862

1. CHECK THE ILLUMINATION OF THE HYDRAULIC PUMP ELECTRIC POWER STEERING WARNING LAMP

Check the hydraulic pump electric power steering warning lamp while engine is running.

Does the hydraulic pump electric power steering warning lamp turn OFF?

YES >> GO TO 2.

NO >> Refer to [STC-31, "Diagnosis Procedure"](#).

2. CHECK WHEEL ALIGNMENT

Check the wheel alignment. Refer to [FSU-21, "Wheel Alignment"](#).

Is the inspection result normal?

YES >> GO TO 3.

NO >> Adjustment of wheel alignment. Refer to [FSU-21, "Wheel Alignment"](#).

3. CHECK STEERING WHEEL TURNING FORCE

Check the steering wheel turning force. Refer to [ST-19, "Inspection"](#).

Is the inspection result normal?

YES >> Inspection End.

NO >> Check the steering wheel turning force for mechanical malfunction. Refer to [ST-23, "Inspection"](#).

UNBALANCE STEERING WHEEL TURNING FORCE (TORQUE VARIATION)

< SYMPTOM DIAGNOSIS >

UNBALANCE STEERING WHEEL TURNING FORCE (TORQUE VARIATION)

Diagnosis Procedure

INFOID:0000000011152863

1. PERFORM SELF-DIAGNOSIS

With CONSULT

Perform "EPS" self-diagnosis.

Is a malfunctioning system displayed?

- YES >> Check malfunctioning system. Refer to [STC-13. "DTC Index"](#).
NO >> GO TO 2.

2. CHECK THE POWER STEERING CONTROL MODULE SIGNAL (1)

With CONSULT

1. Start the engine.

CAUTION:

Never drive the vehicle.

2. Turn the steering wheel until it stops.
3. Select "MTR ASSIST" in "DATA MONITOR" of "EPS".

Is the display value "100%"?

- YES >> GO TO 4.
NO >> GO TO 3.

3. CHECK THE POWER STEERING CONTROL MODULE SIGNAL (2)

With CONSULT

1. Select "C/U TEMP" and "C/U TEMP A" in "DATA MONITOR" of "EPS".
2. Stop the system until the DATA MONITOR display value drops to "90°C (194°F)" or less.
3. Check whether symptom continues.

Did symptom continue?

- YES >> GO TO 4.
NO >> This occurs because the protection function lowers the assist force. It is not a system malfunction.
Inspection End.

4. CHECK THE POWER STEERING CONTROL MODULE SIGNAL (3)

With CONSULT

1. Turn the steering wheel to the straight-ahead position. (There is no steering force.)
2. Select "BATTERY VOLT" in "DATA MONITOR" of "EPS".

Is the display value "10.5 V" or more?

- YES >> GO TO 5.
NO >> Check the battery power system. Refer to [STC-22. "Diagnosis Procedure"](#).

5. CHECK THE POWER STEERING CONTROL MODULE SIGNAL (4)

With CONSULT

Select in "ESTM VHCL SPD" in "DATA MONITOR" of "EPS".

Monitor item	Test condition	Display value
ESTM VHCL SPD	When stopped	0.00 km/h or mph
	While driving	Approximately equal to the indication on speedometer* (Inside of $\pm 10\%$)

*: This may not agree with the speedometer indication immediately after the ignition switch is turned ON. This is not a malfunction.

Is the check result normal?

- YES >> GO TO 6.

UNBALANCE STEERING WHEEL TURNING FORCE (TORQUE VARIATION)

< SYMPTOM DIAGNOSIS >

NO >> Check the combination meter, ABS actuator and electric unit (control unit). Refer to [MWI-18, "CONSULT Function \(METER/M&A\)"](#) and [STC-10, "CONSULT Function"](#).

6. CHECK THE POWER STEERING CONTROL MODULE SIGNAL (5)

With CONSULT

Select "STR ANG SPD" in "DATA MONITOR" of "EPS".

Monitor item	Test condition	Display value
STR ANG SPD	The steering wheel is not turning.	Approx. 0.0 deg/s
	The steering wheel is being turned.	Displays steering angle speed (deg/s)

Is the check result normal?

YES >> GO TO 7.

NO >> Check the steering angle sensor. Refer to [STC-21, "Diagnosis Procedure"](#).

7. CHECK THE POWER STEERING CONTROL MODULE SIGNAL (6)

With CONSULT

Select "ENGINE STATUS" in "DATA MONITOR" of "EPS".

Is the display value "RUN"?

YES >> GO TO 8.

NO >> Check the ECM. Refer to [EC-72, "CONSULT Function"](#) (USA and Canada) or [EC-581, "CONSULT Function"](#) (Mexico).

8. CHECK STEERING COLUMN AND STEERING GEAR

Check the steering column assembly and steering gear assembly.

- Steering column assembly. Refer to [ST-66, "Steering Column"](#).
- Steering gear assembly. Refer to [ST-67, "Power Steering Gear"](#).

Is the inspection result normal?

YES >> GO TO 9.

NO >> Repair or replace malfunctioning component.

9. CHECK STEERING WHEEL TURNING FORCE

Check the steering wheel turning force. Refer to [ST-19, "Inspection"](#).

Is the inspection result normal?

YES >> Inspection End.

NO >> Check the steering wheel turning force for mechanical malfunction. Refer to [ST-23, "Inspection"](#).

POWER STEERING CONTROL MODULE

< REMOVAL AND INSTALLATION >

REMOVAL AND INSTALLATION

POWER STEERING CONTROL MODULE

Removal and Installation

INFOID:000000011152864

CAUTION:

Disconnect battery negative cable before removing the power steering pump assembly.

The power steering control module is an integral part of the power steering pump assembly. If replacement of the power steering control module is necessary, replace the complete power steering pump assembly. Refer to [ST-53. "Removal and Installation"](#).

A
B
C
D
E
F
H
I
J
K
L
M
N
O
P

STC