

SECTION **BR**
BRAKE SYSTEM

A

B

C

D

E

BR

G

H

I

J

K

L

M

N

O

P

CONTENTS

PRECAUTION	3	PERIODIC MAINTENANCE	13
PRECAUTIONS	3	BRAKE PEDAL	13
Precaution for Supplemental Restraint System (SRS) "AIR BAG" and "SEAT BELT PRE-TEN- SIONER"	3	Adjustment	13
Precaution for Procedure without Cowl Top Cover.....	3	BRAKE FLUID	14
Precaution for Brake System	3	Drain and Refill	14
PREPARATION	5	Bleeding Brake System	14
PREPARATION	5	FRONT DISC BRAKE	16
Special Service Tool	5	BRAKE PAD	16
Commercial Service Tool	5	BRAKE PAD : Inspection	16
SYMPTOM DIAGNOSIS	6	DISC ROTOR	16
NOISE, VIBRATION AND HARSHNESS (NVH) TROUBLESHOOTING	6	DISC ROTOR : Inspection	16
NVH Troubleshooting Chart	6	REAR DISC BRAKE	18
BASIC INSPECTION	7	BRAKE PAD	18
BRAKE PEDAL	7	BRAKE PAD : Inspection	18
Inspection	7	DISC ROTOR	18
BRAKE FLUID	8	DISC ROTOR : Inspection	18
Inspection	8	REMOVAL AND INSTALLATION	20
BRAKE MASTER CYLINDER	9	BRAKE PEDAL	20
Inspection	9	Exploded View	20
BRAKE BOOSTER	10	Removal and Installation	20
Inspection	10	BRAKE PIPING	22
FRONT DISC BRAKE	11	FRONT	22
DISC ROTOR	11	FRONT : Exploded View	22
DISC ROTOR : Inspection	11	FRONT : Hydraulic Piping	23
REAR DISC BRAKE	12	FRONT : Removal and Installation	23
DISC ROTOR	12	REAR	24
DISC ROTOR : Inspection	12	REAR : Exploded View	25
PERIODIC MAINTENANCE	13	REAR : Hydraulic Piping	25
BRAKE PEDAL	13	REAR : Removal and Installation	26
Adjustment	13	BRAKE MASTER CYLINDER	28
BRAKE FLUID	14		
Drain and Refill	14		
Bleeding Brake System	14		
FRONT DISC BRAKE	16		
BRAKE PAD	16		
BRAKE PAD : Inspection	16		
DISC ROTOR	16		
DISC ROTOR : Inspection	16		
REAR DISC BRAKE	18		
BRAKE PAD	18		
BRAKE PAD : Inspection	18		
DISC ROTOR	18		
DISC ROTOR : Inspection	18		
REMOVAL AND INSTALLATION	20		
BRAKE PEDAL	20		
Exploded View	20		
Removal and Installation	20		
BRAKE PIPING	22		
FRONT	22		
FRONT : Exploded View	22		
FRONT : Hydraulic Piping	23		
FRONT : Removal and Installation	23		
REAR	24		
REAR : Exploded View	25		
REAR : Hydraulic Piping	25		
REAR : Removal and Installation	26		
BRAKE MASTER CYLINDER	28		

Exploded View	28	BRAKE CALIPER ASSEMBLY	41
Removal and Installation	28	BRAKE CALIPER ASSEMBLY : Exploded View ...	41
Disassembly and Assembly	29	BRAKE CALIPER ASSEMBLY : Removal and In-	
BRAKE BOOSTER	31	stallation	42
Exploded View	31	UNIT DISASSEMBLY AND ASSEMBLY ...	44
Removal and Installation	31	FRONT DISC BRAKE	44
VACUUM LINES	33	Exploded View	44
Exploded View	33	Disassembly and Assembly	44
Removal and Installation	33	REAR DISC BRAKE	47
FRONT DISC BRAKE	35	Exploded View	47
BRAKE PAD	35	Disassembly and Assembly	47
BRAKE PAD : Exploded View	35	SERVICE DATA AND SPECIFICATIONS	
BRAKE PAD : Removal and Installation	35	(SDS)	50
BRAKE CALIPER ASSEMBLY	36	SERVICE DATA AND SPECIFICATIONS	
BRAKE CALIPER ASSEMBLY : Exploded View ...	36	(SDS)	50
BRAKE CALIPER ASSEMBLY : Removal and In-		General Specifications	50
stallation	37	Brake Pedal	50
REAR DISC BRAKE	40	Check Valve	50
BRAKE PAD	40	Brake Booster	50
BRAKE PAD : Exploded View	40	Front Disc Brake	51
BRAKE PAD : Removal and Installation	40	Rear Disc Brake	51

PRECAUTIONS

< PRECAUTION >

PRECAUTION

PRECAUTIONS

Precaution for Supplemental Restraint System (SRS) "AIR BAG" and "SEAT BELT PRE-TENSIONER"

INFOID:000000012551727

The Supplemental Restraint System such as "AIR BAG" and "SEAT BELT PRE-TENSIONER", used along with a front seat belt, helps to reduce the risk or severity of injury to the driver and front passenger for certain types of collision. Information necessary to service the system safely is included in the SR and SB section of this Service Manual.

WARNING:

- To avoid rendering the SRS inoperative, which could increase the risk of personal injury or death in the event of a collision which would result in air bag inflation, it is recommended that all maintenance and repair be performed by an authorized NISSAN/INFINITI dealer.
- Improper repair, including incorrect removal and installation of the SRS, can lead to personal injury caused by unintentional activation of the system. For removal of Spiral Cable and Air Bag Module, see the SR section.
- Do not use electrical test equipment on any circuit related to the SRS unless instructed to in this Service Manual. SRS wiring harnesses can be identified by yellow and/or orange harnesses or harness connectors.

PRECAUTIONS WHEN USING POWER TOOLS (AIR OR ELECTRIC) AND HAMMERS

WARNING:

- When working near the Air Bag Diagnosis Sensor Unit or other Air Bag System sensors with the Ignition ON or engine running, DO NOT use air or electric power tools or strike near the sensor(s) with a hammer. Heavy vibration could activate the sensor(s) and deploy the air bag(s), possibly causing serious injury.
- When using air or electric power tools or hammers, always switch the Ignition OFF, disconnect the battery or batteries, and wait at least three minutes before performing any service.

Precaution for Procedure without Cowl Top Cover

INFOID:000000012551728

When performing the procedure after removing cowl top cover, cover the lower end of windshield with urethane, etc. to prevent damage to windshield.

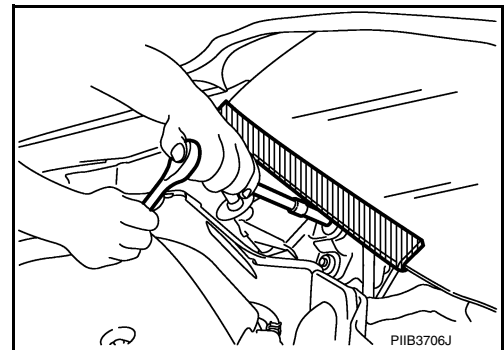

Precaution for Brake System

INFOID:000000012551729

WARNING:

Clean any dust from the front brake and rear brake with a vacuum dust collector. Never blow with compressed air.

CAUTION:

- Brake fluid use refer to [MA-17, "FOR USA AND CANADA : Fluids and Lubricants"](#) (United States and Canada) or [MA-19, "FOR MEXICO : Fluids and Lubricants"](#) (Mexico).
- Do not reuse drained brake fluid.
- Do not spill or splash brake fluid on painted surfaces. Brake fluid may seriously damage paint. Wipe it off immediately and wash with water if it gets on a painted surface.
- Always clean with new brake fluid when cleaning the master cylinder, brake caliper and other components.
- Do not use mineral oils such as gasoline or light oil to clean. They may damage rubber parts and cause improper operation.

PRECAUTIONS

< PRECAUTION >

- Always loosen the brake tube flare nut with a flare nut wrench.
- Tighten the brake tube flare nut to the specified torque with crowfoot (A) and torque wrench (B).
- Always confirm the specified tightening torque when installing the brake pipes.
- Turn the ignition switch OFF and disconnect the ABS actuator and electric unit (control unit) connector or the battery negative terminal before performing the work.
- Check that no brake fluid leakage is present after replacing the parts.
- Burnish the brake contact surfaces after refinishing or replacing rotors, after replacing pads, or if a soft pedal occurs at very low mileage.
- Front brake: refer to [BR-16, "BRAKE PAD : Inspection"](#).
- Rear brake: refer to [BR-18, "BRAKE PAD : Inspection"](#).

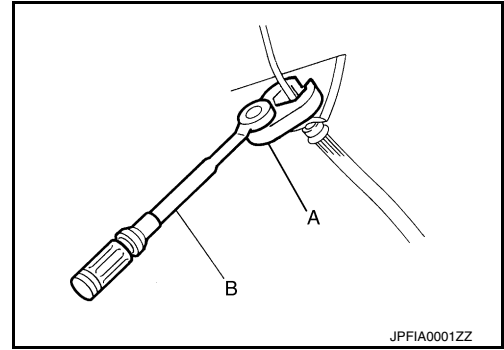

PREPARATION

< PREPARATION >

PREPARATION

PREPARATION

Special Service Tool

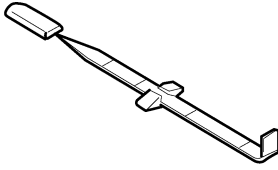
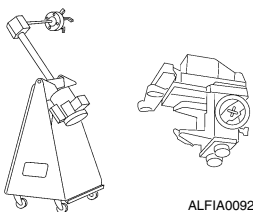

INFOID:0000000012551730

The actual shape of the tools may differ from those illustrated here.

Tool number (TechMate No.) Tool name	Description
<p>— (J-46532) Brake height tool</p>  <p style="text-align: center;">LFIA0227E</p>	<p>Measuring brake pedal height</p>
<p>38-PFM92 (—) ProCut™ PFM Series Lathe</p>  <p style="text-align: center;">ALFIA0092ZZ</p>	<p>Refinishing rotors</p>

Commercial Service Tool

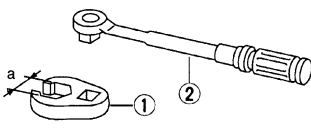
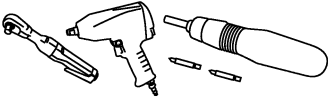
INFOID:0000000012551731

Tool name	Description
<p>1. Flare nut crowfoot 2. Torque wrench</p>  <p style="text-align: center;">S-NT360</p>	<p>Tightening brake tube flare nuts a: 10 mm (0.39 in)/12 mm (0.47 in)</p>
<p>Power tool</p>  <p style="text-align: center;">PIIB1407E</p>	<p>Loosening nuts, screws and bolts</p>
<p>Vacuum pump</p>  <p style="text-align: center;">ZZC1313D</p>	<ul style="list-style-type: none"> • Air tight • Inspection of check valve

NOISE, VIBRATION AND HARSHNESS (NVH) TROUBLESHOOTING

< SYMPTOM DIAGNOSIS >

SYMPTOM DIAGNOSIS

NOISE, VIBRATION AND HARSHNESS (NVH) TROUBLESHOOTING

NVH Troubleshooting Chart

INFOID:000000012551732

Use the chart below to find the cause of the symptom. If necessary, repair or replace these parts.

Symptom		Possible cause and SUSPECTED PARTS		Reference page																			
				BR-16 , BR-18 BR-11 , BR-12 , BR-16 , BR-18 BR-11 , BR-12 , BR-16 , BR-18 BR-16 , BR-18 BR-16 , BR-18 BR-16 , BR-18 BR-16 , BR-18 BR-16 , BR-18 BR-11 , BR-12 , BR-16 , BR-18 DLN-100 DLN-113 FAX-5 RAX-4 FSU-3 RSU-4 WT-57 WT-57 FAX-5 RAX-4 ST-42																			
BRAKE	Noise	x	x	x																			
	Shake				x																		
	Shimmy, Shudder				x	x	x	x	x	x	x												

x: Applicable

BRAKE PEDAL

< BASIC INSPECTION >

BASIC INSPECTION

BRAKE PEDAL

Inspection

INFOID:000000012551733

BRAKE PEDAL HEIGHT

Check the brake pedal height (H_1) between the dash lower panel (1) and the brake pedal upper surface.

Brake pedal height (H_1) : Refer to [BR-50, "Brake Pedal"](#).

CAUTION:

Check the brake pedal height with the floor trim removed.

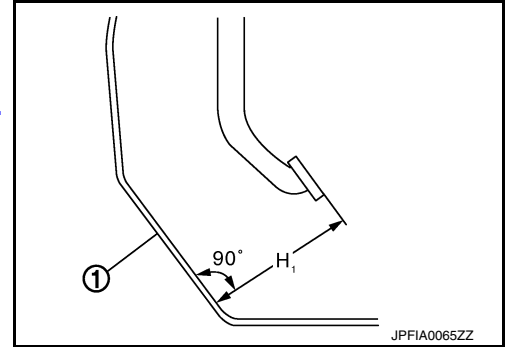

STOP LAMP SWITCH AND BRAKE PEDAL POSITION SWITCH

Check the clearance (A) between the switch assembly bracket (3), the stop lamp switch (1) and the brake pedal position switch (2).

Clearance (A) : Refer to [BR-50, "Brake Pedal"](#).

CAUTION:

The stop lamp must turn off when the brake pedal is released.

NOTE:

Pull the brake pedal pad to check that both the stop lamp switch (1) and brake pedal position switch (2) contact ends to brake pedal bracket (3) clearance (A) are within specification.

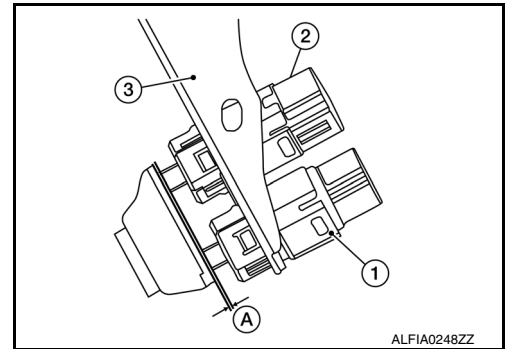

BRAKE PEDAL PLAY

Check that brake pedal play does not exist.

BRAKE PEDAL FULL STROKE

Check that the brake pedal moves smoothly within the specified range.

Brake pedal full stroke (H_2) : Refer to [BR-50, "Brake Pedal"](#).

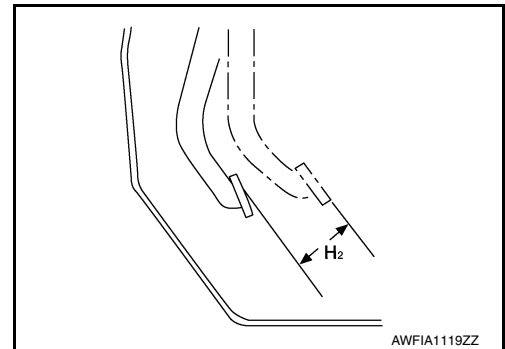

DEPRESSED BRAKE PEDAL HEIGHT

Check the brake pedal height (H_3) between the dash lower panel (1) and the brake pedal upper surface when depressing the brake pedal at 490 N (50 kg, 110 lb) while turning engine ON.

Depressed brake pedal height (H_3) : Refer to [BR-50, "Brake Pedal"](#).

CAUTION:

Check the depressed brake pedal height with the floor trim removed.

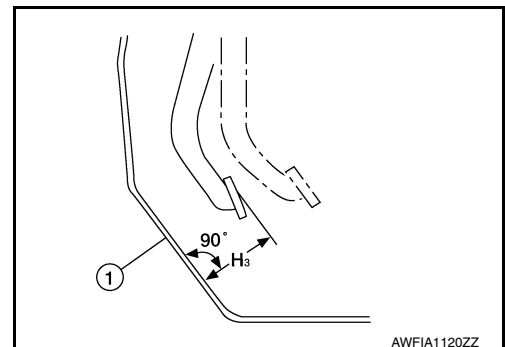

BRAKE FLUID

< BASIC INSPECTION >

BRAKE FLUID

Inspection

INFOID:000000012551734

BRAKE FLUID LEVEL

- Make sure that the brake fluid level in the reservoir sub tank is between the MAX and MIN lines.
- Visually check around the reservoir sub tank and reservoir tank for brake fluid leakage.
- If the brake fluid level is excessively low, check the brake system for leakage.
- If brake warning lamp remains illuminated after parking brake pedal is released, check the brake system for brake fluid leakage.

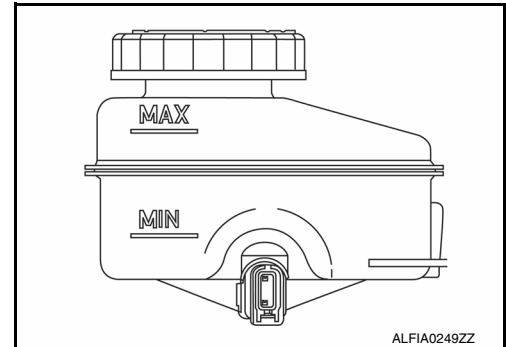

BRAKE LINE

1. Check brake line (tubes and hoses) for cracks, deterioration or other damage. Replace any damaged parts.
2. Check for brake fluid leakage by fully depressing brake pedal while engine is running.

CAUTION:

If brake fluid leakage occurs around joints, retighten or replace damaged parts as necessary.

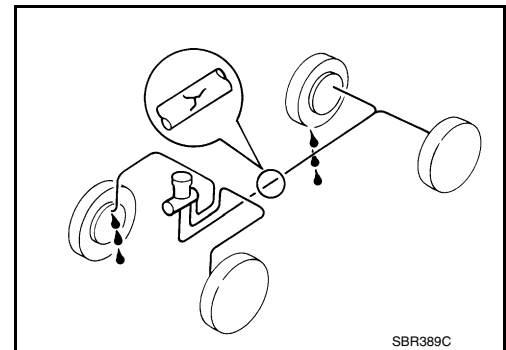

BRAKE MASTER CYLINDER

< BASIC INSPECTION >

BRAKE MASTER CYLINDER

Inspection

INFOID:000000012551735

Check for brake fluid leakage at the following areas:

- Master cylinder mounting face
- Reservoir tank mounting face
- Reservoir sub tank mounting face
- Brake tube and brake tube connections
- Brake hose and brake hose connections

If any brake fluid leakage is found, repair as necessary.

A

B

C

D

E

BR

G

H

I

J

K

L

M

N

O

P

BRAKE BOOSTER

< BASIC INSPECTION >

BRAKE BOOSTER

Inspection

INFOID:000000012551736

Operation

Depress the brake pedal several times at five second intervals with the engine stopped. Start the engine with the brake pedal fully depressed. Check that the clearance between brake pedal and dash lower panel decreases.

NOTE:

A slight impact with a small click may be felt on the pedal when the brake pedal is fully depressed. This is normal brake system operation.

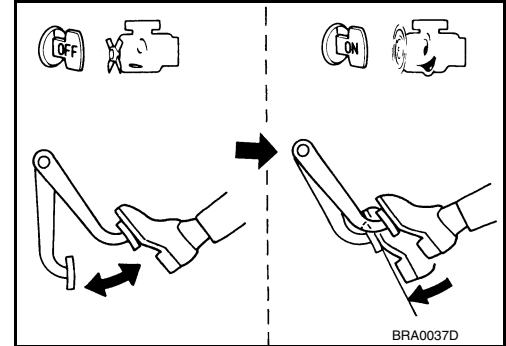

Vacuum Inspection

Idle the engine for one minute to apply vacuum to the brake booster. Stop the engine. Depress the brake pedal several times at five second intervals until the accumulated vacuum is released to atmospheric pressure. Check that the clearance between brake pedal and dash lower panel gradually increases (A → B → C) each time the brake pedal is depressed during this operation.

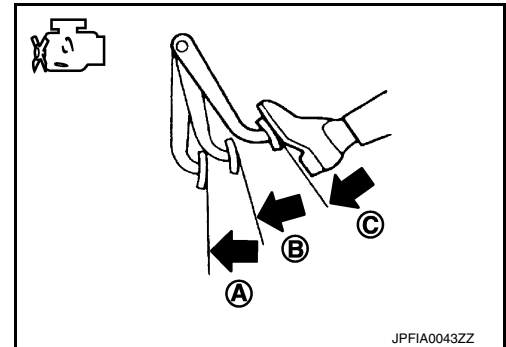

Depress the brake pedal with the engine running. Then stop the engine while holding down the brake pedal. Check that the brake pedal stroke does not change after holding down the brake pedal for 30 seconds or more.

NOTE:

A slight impact with a small click may be felt on the pedal when the brake pedal is fully depressed. This is normal brake system operation.

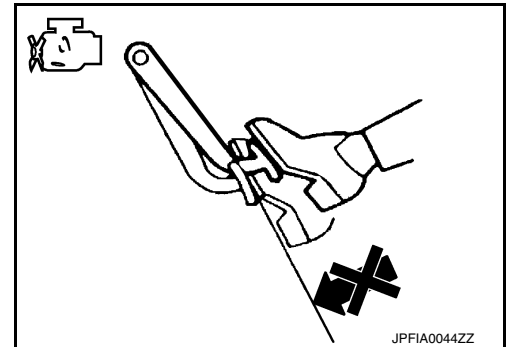

FRONT DISC BRAKE

< BASIC INSPECTION >

FRONT DISC BRAKE

DISC ROTOR

DISC ROTOR : Inspection

INFOID:0000000012996494

INSPECTION

Uneven wear

Check for uneven wear of the disc brake rotor using a micrometer.
Replace the disc brake rotor if the thickness is below the wear limit.

Thickness variation : Refer to [BR-51, "Front Disc Brake"](#).
(measured at 8 positions)

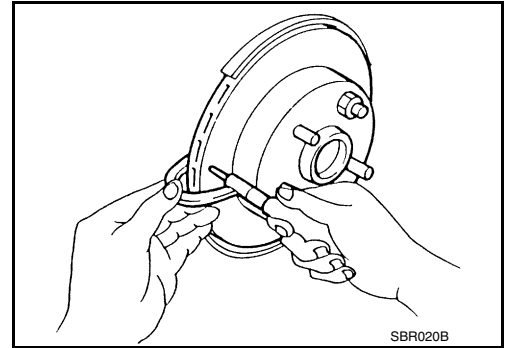

A

B

C

D

E

BR

G

H

I

J

K

L

M

N

O

P

REAR DISC BRAKE

< BASIC INSPECTION >

REAR DISC BRAKE

DISC ROTOR

DISC ROTOR : Inspection

INFOID:000000012996495

INSPECTION

Uneven wear

Check for uneven wear of the disc brake rotor using a micrometer.
Replace the disc brake rotor if the thickness is below the wear limit.

Thickness variation : Refer to [BR-51, "Rear Disc Brake"](#).
(measured at 8 positions)

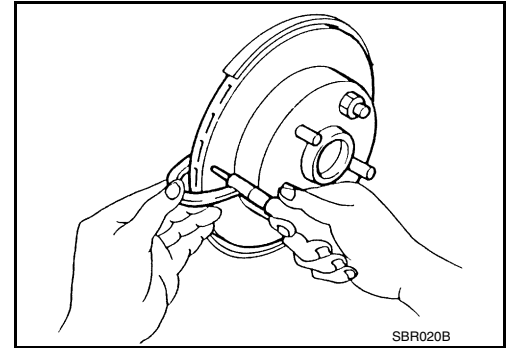

BRAKE PEDAL

< PERIODIC MAINTENANCE >

PERIODIC MAINTENANCE

BRAKE PEDAL

Adjustment

INFOID:0000000012551741

BRAKE PEDAL HEIGHT

1. Remove instrument lower panel LH. Refer to [IP-25, "Removal and Installation"](#).
2. Disconnect the harness connectors from the stop lamp switch and brake pedal position switch.
3. Turn the stop lamp switch and brake pedal position switch 45° counterclockwise.
4. Loosen the input rod lock nut (1). Adjust the brake pedal height to the specification.

CAUTION:

- Check the height with the floor trim removed.
- The threaded end of the input rod (2) must project to the inner side (L) of the clevis (3).

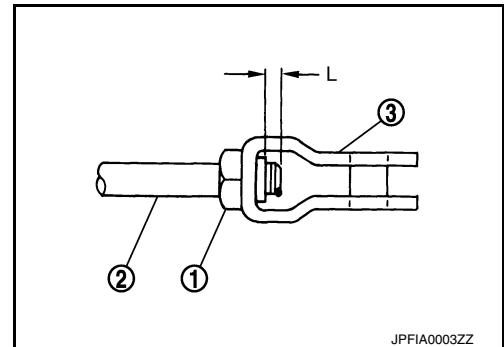

Brake pedal height (H1) : Refer to [BR-50, "Brake Pedal"](#).

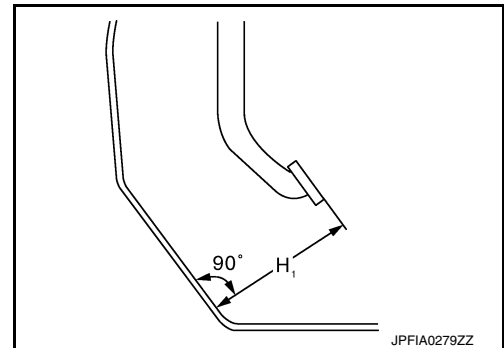

5. Tighten the input rod lock nut to specification. Refer to [BR-31, "Exploded View"](#).
6. Check the brake pedal for smooth operation.

CAUTION:

The stop lamp must turn off when the brake pedal is released.

STOP LAMP SWITCH AND BRAKE PEDAL POSITION SWITCH

1. Remove instrument lower panel LH. Refer to [IP-25, "Removal and Installation"](#).
2. Disconnect the harness connectors from the stop lamp switch and brake pedal position switch.
3. Turn the stop lamp switch and brake pedal position switch 45° counterclockwise.
4. With the threaded ends of the stop lamp switch (1) and brake pedal position switch (2) contacting the pedal bracket (3), turn the switches 45° clockwise to lock in place. Check that both the stop lamp switch (1) and brake pedal position switch (2) contact ends to brake pedal bracket (3) clearance (A) are within specification.

CAUTION:

- Make sure that the clearance (A) between the brake pedal bracket (3), stop lamp switch (1) and the brake pedal position switch (2) contact ends are within specification.
- The stop lamp must turn off when the brake pedal is released.

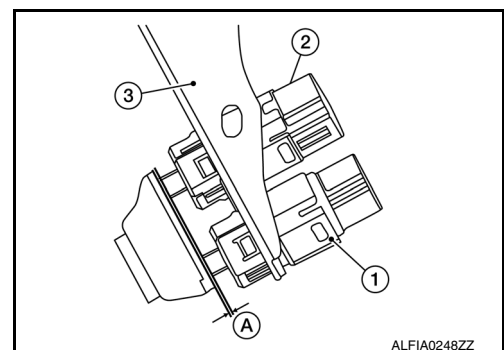

Clearance (A) : Refer to [BR-50, "Brake Pedal"](#).

BRAKE FLUID

< PERIODIC MAINTENANCE >

BRAKE FLUID

Drain and Refill

INFOID:000000012551742

CAUTION:

- Do not spill or splash brake fluid on painted surfaces. Brake fluid may damage paint. If brake fluid is splashed on painted areas, wash it away with water immediately.
- Prior to repair, turn the ignition switch OFF, disconnect the ABS actuator and electric unit (control unit) connector or negative battery terminal. Refer to [PG-93, "Removal and Installation"](#).
- Refill brake system with new brake fluid. Refer to [MA-17, "FOR USA AND CANADA : Fluids and Lubricants"](#) (United States and Canada) or [MA-19, "FOR MEXICO : Fluids and Lubricants"](#) (Mexico).
- Do not reuse drained brake fluid.

DRAINING

1. Turn ignition switch OFF and disconnect ABS actuator and electric unit (control unit) connector or negative battery terminal. Refer to [PG-93, "Removal and Installation"](#).
2. Connect a vinyl tube to bleeder valve.
3. Depress brake pedal, loosen bleeder valve, and gradually remove brake fluid.

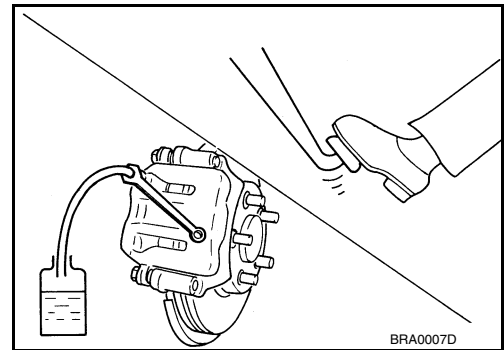

REFILLING

1. Make sure no foreign material is in the reservoir sub-tank, and refill with new brake fluid.

CAUTION:

Do not reuse drained brake fluid.

2. Refill the brake system as follows:
 - Depress the brake pedal.
 - Loosen bleeder valve.
 - Slowly depress brake pedal to 2/3 of the brake pedal full stroke.
 - Tighten bleeder valve.
 - Release brake pedal.

Repeat this operation at intervals of two or three seconds until

all old brake fluid is discharged. Add new brake fluid to master cylinder reservoir sub tank frequently.

CAUTION:

Do not allow master cylinder reservoir to empty as this may cause damage to master cylinder internal components.

3. Bleed the air out of the brake hydraulic system. Refer to [BR-14, "Bleeding Brake System"](#).

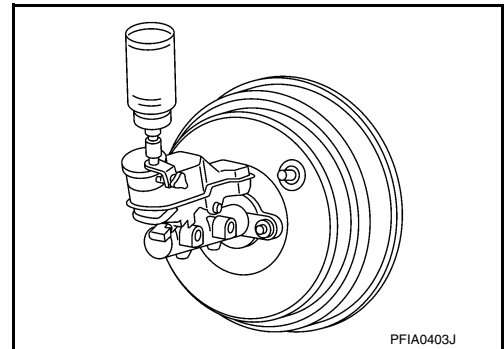

Bleeding Brake System

INFOID:000000012551743

CAUTION:

- While bleeding, pay attention to master cylinder fluid level.
- Before working, disconnect ABS actuator and electric unit (control unit) connectors or negative battery terminal. Refer to [PG-93, "Removal and Installation"](#).

1. Turn ignition switch OFF and disconnect ABS actuator and electric unit (control unit) connector or negative battery terminal. Refer to [PG-93, "Removal and Installation"](#).
2. Connect a vinyl tube to front right brake caliper bleeder valve.
3. Fully depress brake pedal 4 or 5 times.

BRAKE FLUID

< PERIODIC MAINTENANCE >

4. With brake pedal depressed, loosen bleeder valve to bleed air in brake line, and then tighten it immediately.
5. Repeat steps 3 and 4 until all of the air is out of the brake line.
6. Tighten the bleeder valve to the specified torque. Refer to [BR-44. "Exploded View"](#) (front disc brake), [BR-47. "Exploded View"](#) (rear disc brake).
7. Repeat steps 2 through 6, with master cylinder reservoir tank filled at least halfway. Bleed the air in the following order: front right, front left, rear right, rear left.

A

B

C

D

E

BR

G

H

I

J

K

L

M

N

O

P

FRONT DISC BRAKE

< PERIODIC MAINTENANCE >

FRONT DISC BRAKE BRAKE PAD

BRAKE PAD : Inspection

INFOID:000000012551737

PAD WEAR

Check brake pad wear thickness from an inspection hole (A) on cylinder body. Check using a scale if necessary.

Wear thickness : Refer to [BR-51, "Front Disc Brake"](#).

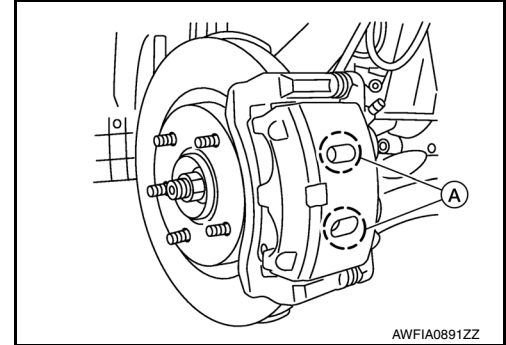

ADJUSTMENT

Burnish contact surfaces between disc brake rotor and brake pads according to the following procedure after refinishing disc brake rotors, replacing disc brake rotors, replacing brake pads, or if a soft pedal occurs at very low mileage:

CAUTION:

- **Be careful of vehicle speed because the brake pedal does not operate firmly/securely until pads and disc brake rotor are securely seated.**
- **Only perform this procedure under safe road and traffic conditions. Use extreme caution.**

1. Drive vehicle on straight, flat road.
2. Depress brake pedal with the power to stop vehicle within 3 to 5 seconds until the vehicle stops.
3. Drive without depressing brake pedal for a few minutes to cool the brakes.
4. Repeat steps 1 to 3 until pad and disc brake rotor are securely seated.

DISC ROTOR

DISC ROTOR : Inspection

INFOID:000000012551738

INSPECTION

Appearance

Check surface of disc rotor for uneven wear, cracks, and serious damage. Replace as necessary.

Runout

1. Check the wheel bearing axial end play before the inspection. Refer to [FAX-6, "Inspection"](#).
2. Secure the disc rotor to the wheel hub and bearing with wheel nuts at two wheel nut locations.
3. Inspect the runout with a dial gauge, measured at 10 mm (0.39 in) inside the disc edge.

Runout : Refer to [BR-51, "Front Disc Brake"](#).

4. Find the installation position with a minimum runout by shifting the disc rotor-to-wheel hub and bearing installation position by one hole at a time if the runout exceeds the limit value.
5. Refinish the disc rotor if the runout is outside the limit even after performing the above operation. When refinishing, use Tool.

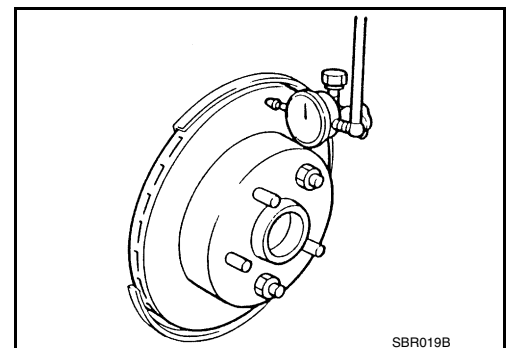

Tool number : 38-PFM92 (—)

CAUTION:

FRONT DISC BRAKE

< PERIODIC MAINTENANCE >

- Check in advance that the thickness of the disc rotor is wear thickness + 0.3 mm (0.012 in) or more.
- If the thickness is less than wear thickness + 0.3 mm (0.012 in), replace the disc rotor. Refer to [RAX-7, "Removal and Installation"](#).

Wear thickness : Refer to [BR-51, "Front Disc Brake"](#).

Thickness

Check the thickness of the disc rotor using a micrometer. Replace the disc rotor if the thickness is below the wear limit.

Wear thickness : Refer to [BR-51, "Front Disc Brake"](#).

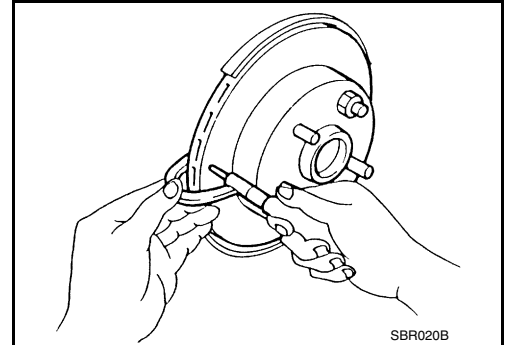

ADJUSTMENT

Burnish contact surfaces between disc brake rotor and brake pads according to the following procedure after refinishing disc brake rotors, replacing disc brake rotors, replacing brake pads, or if a soft pedal occurs at very low mileage:

CAUTION:

- Be careful of vehicle speed because the brake pedal does not operate firmly/securely until pads and disc brake rotor are securely seated.
 - Only perform this procedure under safe road and traffic conditions. Use extreme caution.
1. Drive vehicle on straight, flat road.
 2. Depress brake pedal with the power to stop vehicle within 3 to 5 seconds until the vehicle stops.
 3. Drive without depressing brake pedal for a few minutes to cool the brakes.
 4. Repeat steps 1 to 3 until pad and disc brake rotor are securely seated.

REAR DISC BRAKE

< PERIODIC MAINTENANCE >

REAR DISC BRAKE BRAKE PAD

BRAKE PAD : Inspection

INFOID:000000012551739

INSPECTION

Check brake pad wear thickness from an inspection hole (A) on cylinder body. Check using a scale if necessary.

Wear thickness : Refer to [BR-51, "Rear Disc Brake"](#).

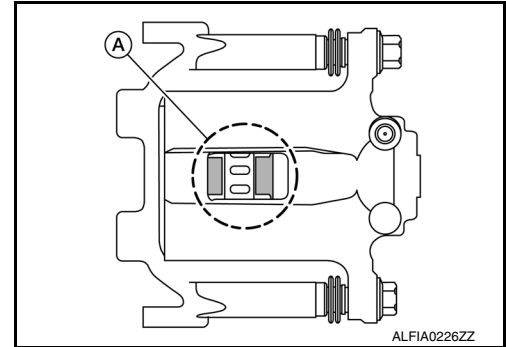

ADJUSTMENT

Burnish contact surfaces between disc brake rotor and brake pads according to the following procedure after refinishing disc brake rotors, replacing disc brake rotors, replacing brake pads, or if a soft pedal occurs at very low mileage:

CAUTION:

- **Be careful of vehicle speed because the brake pedal does not operate firmly/securely until pads and disc brake rotor are securely seated.**
 - **Only perform this procedure under safe road and traffic conditions. Use extreme caution.**
1. Drive vehicle on straight, flat road.
 2. Depress brake pedal with the power to stop vehicle within 3 to 5 seconds until the vehicle stops.
 3. Drive without depressing brake pedal for a few minutes to cool the brakes.
 4. Repeat steps 1 to 3 until pad and disc brake rotor are securely seated.

DISC ROTOR

DISC ROTOR : Inspection

INFOID:000000012551740

INSPECTION

Appearance

Check surface of disc rotor for uneven wear, cracks, and serious damage. Replace as necessary.

Runout

1. Check the wheel bearing axial end play before the inspection. Refer to [RAX-5, "Inspection"](#).
2. Secure the disc rotor to the wheel hub and bearing with wheel nuts at two wheel nut locations.
3. Measure the runout with a dial gauge 10 mm (0.39 in) from the disc rotor edge.

Runout : Refer to [BR-51, "Rear Disc Brake"](#).

4. Find the installation position with a minimum runout by shifting the disc rotor-to-wheel hub and bearing installation position by one hole at a time if the runout exceeds the limit value.
5. Refinish the disc rotor if the runout is outside the limit even after performing the above operation. When refinishing, use Tool.

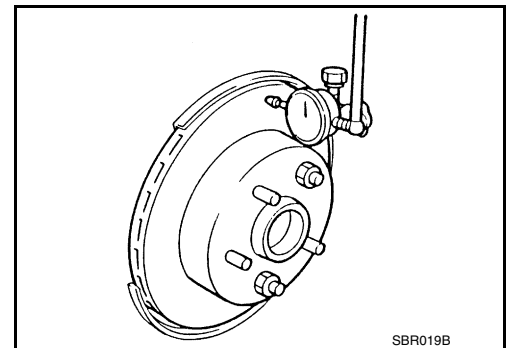

Tool number : 38-PFM92 (—)

CAUTION:

REAR DISC BRAKE

< PERIODIC MAINTENANCE >

- Check in advance that the thickness of the disc rotor is wear thickness + 0.3 mm (0.012 in) or more.
- If the thickness is less than wear thickness + 0.3 mm (0.012 in), replace the disc rotor. Refer to [FAX-11, "WHEEL SIDE : Removal and Installation"](#).

Wear thickness : Refer to [BR-51, "Rear Disc Brake"](#).

Thickness

Check the thickness of the disc rotor using a micrometer. Replace the disc rotor if the thickness is below the minimum thickness.

Wear thickness : Refer to [BR-51, "Rear Disc Brake"](#).

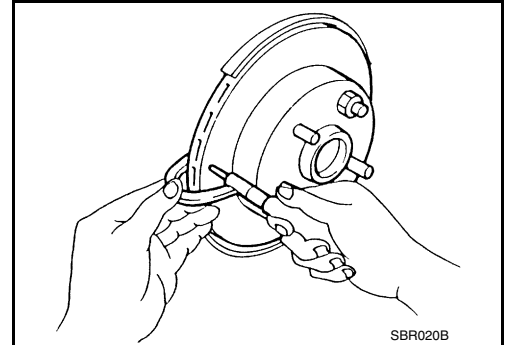

ADJUSTMENT

Burnish contact surfaces between disc brake rotor and brake pads according to the following procedure after refinishing disc brake rotors, replacing disc brake rotors, replacing brake pads, or if a soft pedal occurs at very low mileage:

CAUTION:

- **Be careful of vehicle speed because the brake pedal does not operate firmly/securely until pads and disc brake rotor are securely seated.**
 - **Only perform this procedure under safe road and traffic conditions. Use extreme caution.**
1. Drive vehicle on straight, flat road.
 2. Depress brake pedal with the power to stop vehicle within 3 to 5 seconds until the vehicle stops.
 3. Drive without depressing brake pedal for a few minutes to cool the brakes.
 4. Repeat steps 1 to 3 until pad and disc brake rotor are securely seated.

BRAKE PEDAL

< REMOVAL AND INSTALLATION >

REMOVAL AND INSTALLATION

BRAKE PEDAL

Exploded View

INFOID:000000012551746

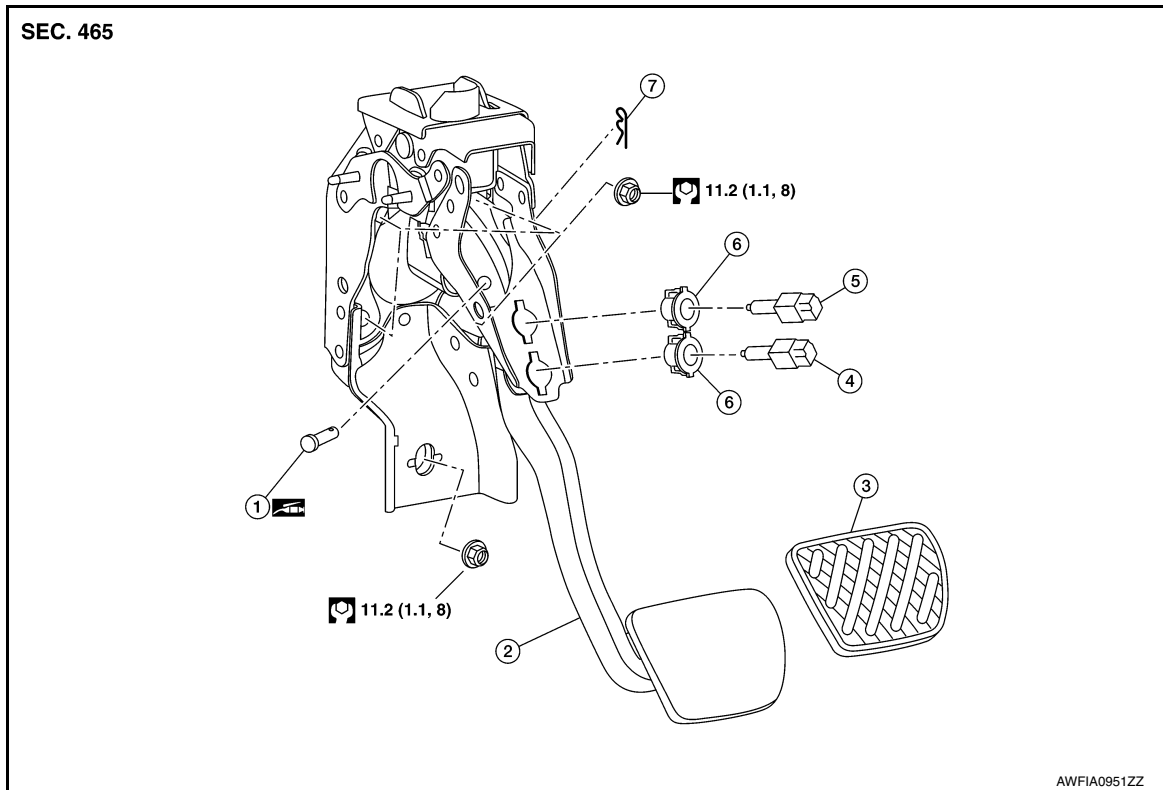

- | | | |
|---------------------|--------------------------------|--------------------|
| 1. Clevis pin | 2. Brake pedal assembly | 3. Brake pedal pad |
| 4. Stop lamp switch | 5. Brake pedal position switch | 6. Clip |
| 7. Snap pin | | |

Removal and Installation

INFOID:000000012551747

REMOVAL

1. Remove instrument lower panel LH. Refer to [IP-25, "Removal and Installation"](#).
2. Remove sonar control unit (if equipped). Refer to [SN-34, "Removal and Installation"](#).
3. Disconnect the harness connectors from the stop lamp switch and the brake pedal position switch.
4. Remove wire harness clips from brake pedal assembly.
5. Remove snap pin and clevis pin from clevis of brake booster.
6. Remove the brake pedal assembly.

CAUTION:

Support the brake booster and master cylinder to prevent contact with other components.

INSPECTION AFTER REMOVAL

BRAKE PEDAL

< REMOVAL AND INSTALLATION >

- Check the following items and replace the brake pedal assembly if necessary.
- Check the brake pedal upper rivet (made of aluminum) (A) for deformation.
- Check the brake pedal for bend, damage, and cracks on the welded parts.
- Check the overlap distance (X) of sub-bracket (B) and slide plate (C).

Distance (X) : 5.5 ± 0.5 mm (0.217 ± 0.020 in)

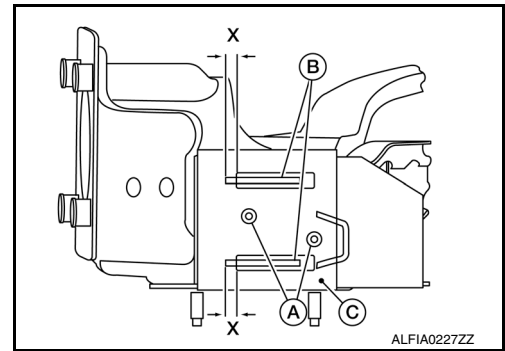

INSTALLATION

Installation is in the reverse order of removal.

- Inspect the brake pedal height and play after installing the brake pedal to the vehicle. Adjust if necessary refer to [BR-7, "Inspection"](#).

A
B
C
D
E
G
H
I
J
K
L
M
N
O
P

BR

BRAKE PIPING

< REMOVAL AND INSTALLATION >

BRAKE PIPING

FRONT

FRONT : Exploded View

INFOID:000000012551748

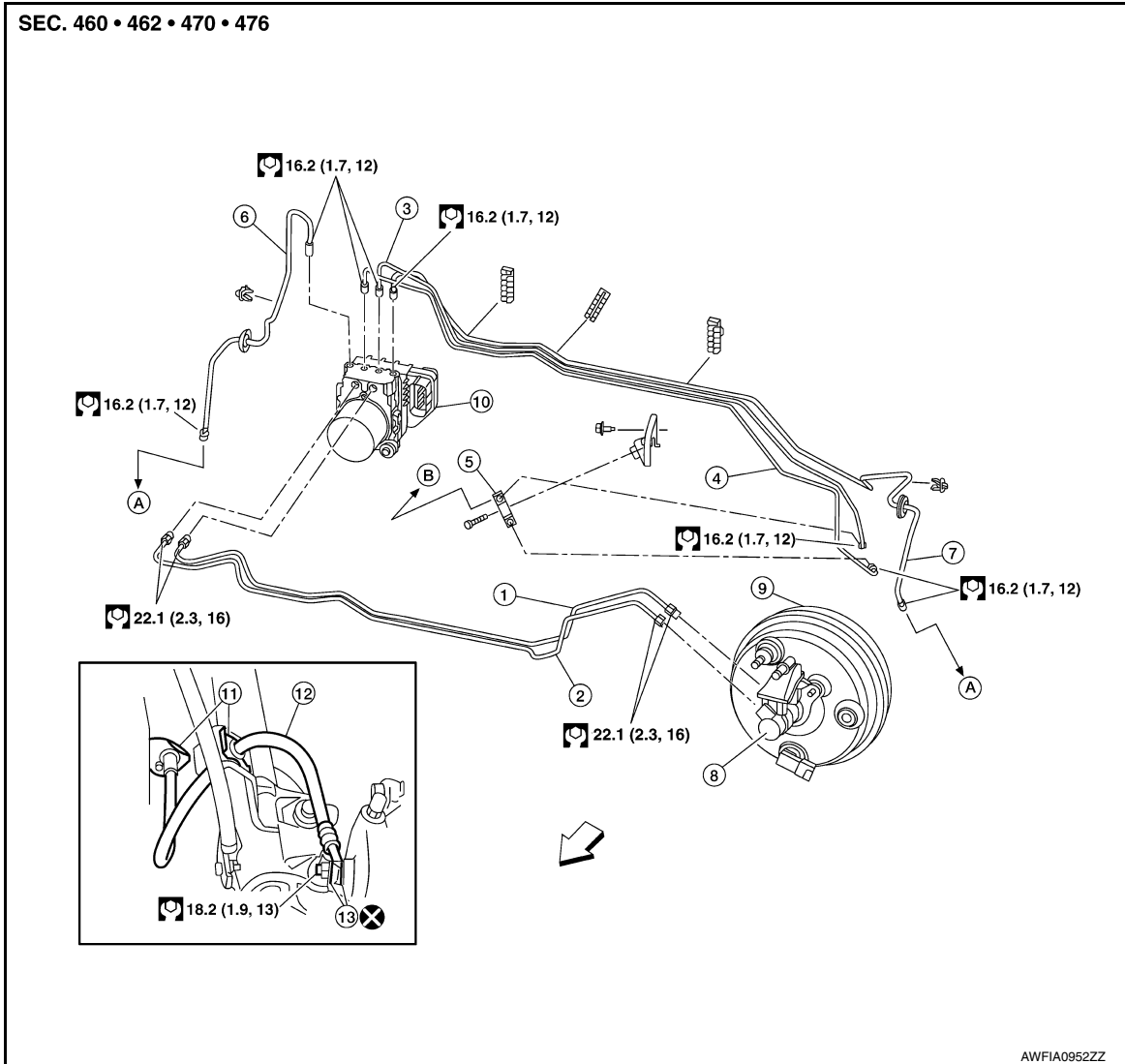

- | | | |
|---|--|---|
| 1. Master cylinder brake pipe assembly (rear) | 2. Master cylinder brake pipe assembly (front) | 3. ABS actuator to connector brake pipe assembly - (RH) |
| 4. ABS actuator to connector brake pipe assembly (LH) | 5. Brake pipe connector | 6. Brake pipe assembly (RH front) |
| 7. Brake pipe assembly (LH front) | 8. Master cylinder assembly | 9. Brake booster |
| 10. ABS actuator and electric unit (control unit) | 11. Lock plate | 12. Front brake hose |
| 13. Copper sealing washer | A. To front brake hose | B. To rear brake pipe |
- ⇐ Front

BRAKE PIPING

< REMOVAL AND INSTALLATION >

FRONT : Hydraulic Piping

INFOID:000000012551749

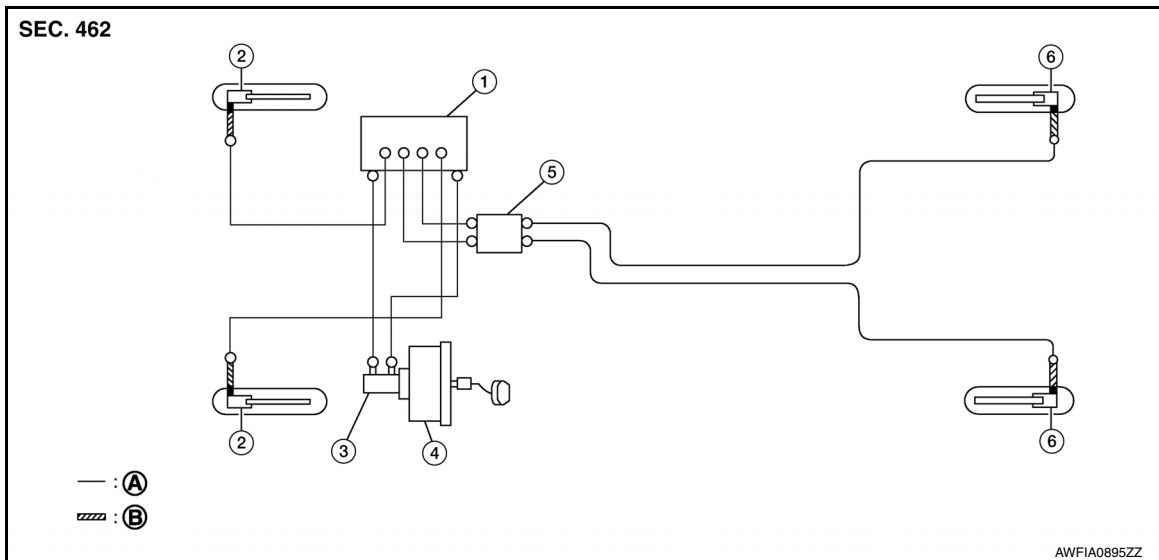

- | | | |
|--|---------------------|-----------------------------|
| 1. ABS actuator and electric unit (control unit) | 2. Front disc brake | 3. Master cylinder assembly |
| 4. Brake booster | 5. Connector | 6. Rear disc brake |
| A. Brake tube | B. Brake hose | |

- : Flare nut
■ : Union bolt

CAUTION:

- Make sure that interference does not exist with other parts when turning steering both clockwise and counterclockwise.
- Do not spill or splash brake fluid on painted areas; it may cause paint damage. If brake fluid is splashed on painted areas, wash it away with water immediately.
- Do not bend, twist or pull the brake hoses and piping.
- When removing components, cover connections to avoid dirt, dust, or other foreign matter from entering the brake system.
- Do not reuse drained brake fluid.
- After installation of the ABS actuator and electric unit (control unit), refill brake system with new brake fluid. Then bleed the air from the system. Refer to [BR-14, "Bleeding Brake System"](#).

FRONT : Removal and Installation

INFOID:000000012551750

NOTE:

When removing components such as hoses, tubes/lines, etc., cap or plug openings to prevent fluid from spilling.

REMOVAL

1. Remove wheels and tires using power tool. Refer to [WT-59, "Adjustment"](#).
2. Loosen the flare nut with a flare nut wrench and separate the brake tube from the hose.

CAUTION:

- Do not scratch the flare nut and the brake pipe.
- All brake hoses and pipes must be free from excessive bending, twisting and pulling.

BRAKE PIPING

< REMOVAL AND INSTALLATION >

3. Remove the union bolt (A) and the brake hose from the brake caliper. Remove and discard the copper sealing washers (1).
CAUTION:
Do not reuse copper sealing washers.
4. Remove the lock plate and remove the brake hose.

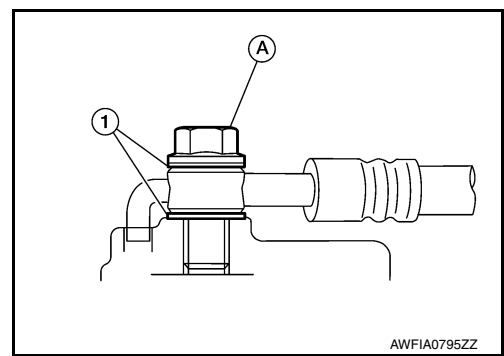

INSTALLATION

CAUTION:

Do not allow foreign matter (e.g. dust) and oils other than brake fluid to enter the reservoir tank.

1. Assemble the union bolt (A) and the copper sealing washers (1) to the brake hose and install it as an assembly to the brake caliper. Align the brake hose L-pin by aligning it with the brake caliper hole, and tighten the union bolt (A) to the specified torque.

CAUTION:

Do not reuse copper sealing washers.

2. Install the brake pipe to the brake hose, temporarily tighten the flare nut by hand until it does not rotate further, and attach the brake hose to the bracket with the lock plate.

CAUTION:

Check that the brake hoses and pipes are not bent or twisted.

3. Tighten the flare nut to the specified torque with a crowfoot and a torque wrench.

CAUTION:

Do not scratch the flare nut and the brake pipe.

4. Refill with new brake fluid and perform the air bleeding. Refer to [BR-14, "Bleeding Brake System"](#).

CAUTION:

Do not reuse drained brake fluid.

5. Install the wheels and tires. Refer to [WT-59, "Adjustment"](#).
6. Perform inspection after installation. Refer to [BR-8, "Inspection"](#).

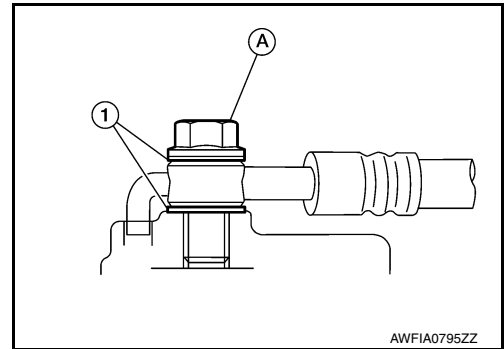

REAR

BRAKE PIPING

< REMOVAL AND INSTALLATION >

REAR : Exploded View

INFOID:000000012551751

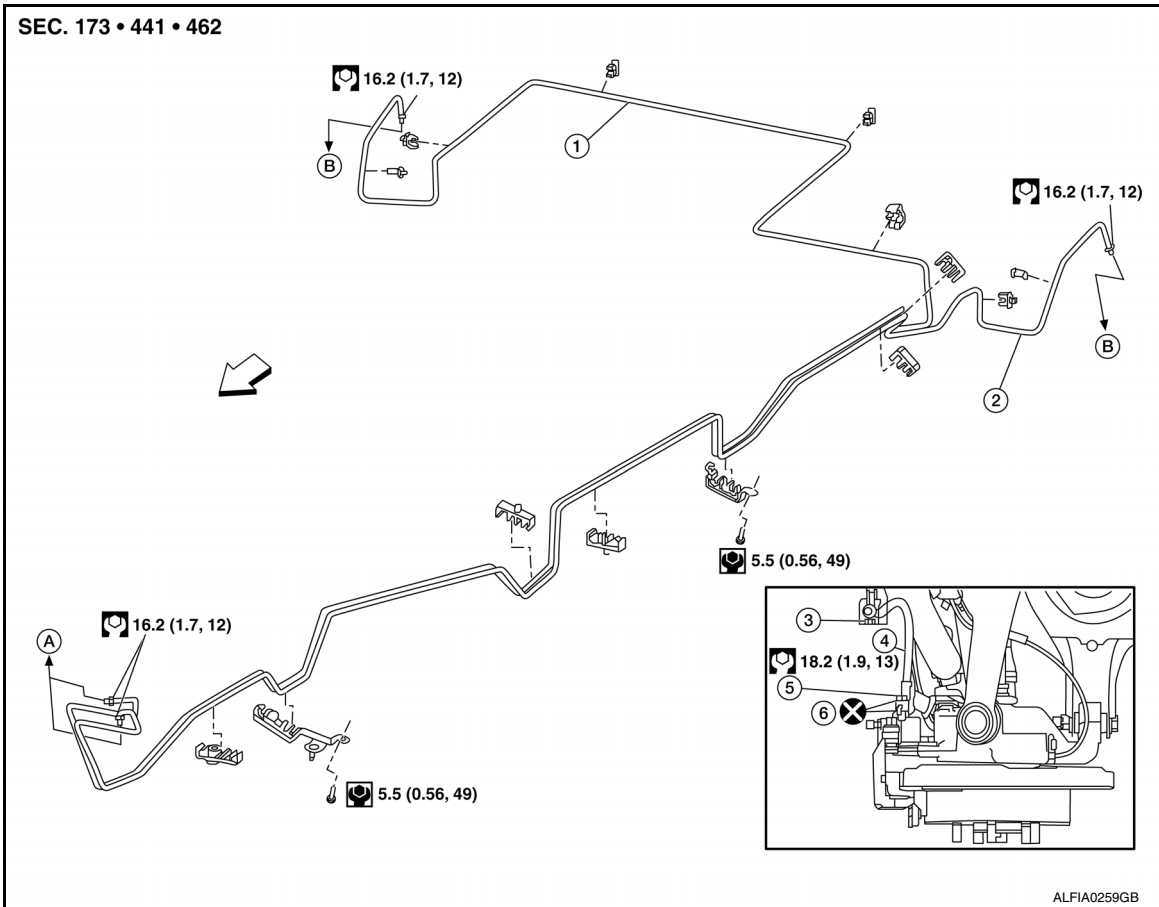

- | | | |
|----------------------------------|----------------------------------|---------------------------|
| 1. Rear brake pipe assembly (RH) | 2. Rear brake pipe assembly (LH) | 3. Lock plate |
| 4. Rear brake hose | 5. Union bolt | 6. Copper sealing washers |
| A. To brake pipe connector | B. To rear brake hose | ⇐ Front |

REAR : Hydraulic Piping

INFOID:000000012551752

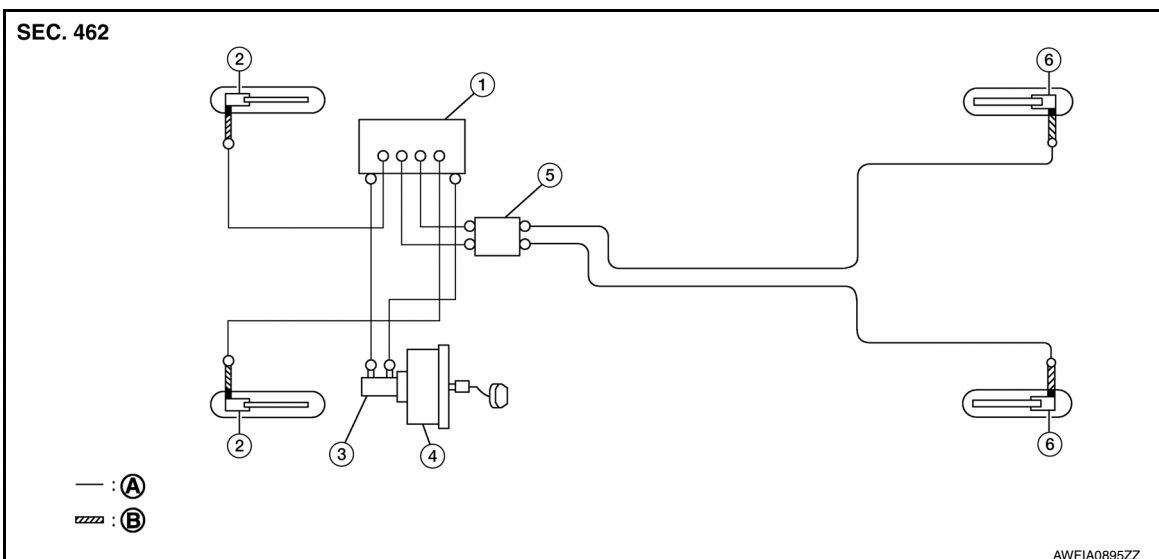

BRAKE PIPING

< REMOVAL AND INSTALLATION >

- | | | |
|--|---------------------|-----------------------------|
| 1. ABS actuator and electric unit (control unit) | 2. Front disc brake | 3. Master cylinder assembly |
| 4. Brake booster | 5. Connector | 6. Rear disc brake |
| A. Brake tube | B. Brake hose | |

○: Flare nut

■: Union bolt

CAUTION:

- Make sure that interference does not exist with other parts when turning steering both clockwise and counterclockwise.
- Do not spill or splash brake fluid on painted areas; it may cause paint damage. If brake fluid is splashed on painted areas, wash it away with water immediately.
- Do not bend, twist or pull the brake hoses and piping.
- When removing components, cover connections to avoid dirt, dust, or other foreign matter from entering the brake system.
- Do not reuse drained brake fluid.
- After installation of the ABS actuator and electric unit (control unit), refill brake system with new brake fluid. Then bleed the air from the system. Refer to [BR-14, "Bleeding Brake System"](#).

REAR : Removal and Installation

INFOID:0000000012551753

NOTE:

When removing components such as hoses, tubes/lines, etc., cap or plug openings to prevent fluid from spilling.

REMOVAL

1. Remove wheels and tires using power tool. Refer to [WT-59, "Adjustment"](#).
2. Loosen the flare nut with a flare nut wrench and separate the brake tube from the hose.

CAUTION:

- Do not scratch the flare nut and the brake pipe.
- All brake hoses and pipes must be free from excessive bending, twisting and pulling.

3. Remove the union bolt (A) and the brake hose from the brake caliper. Remove and discard the copper sealing washers (1).

CAUTION:

Do not reuse copper sealing washers.

4. Remove the lock plate and remove the brake hose.

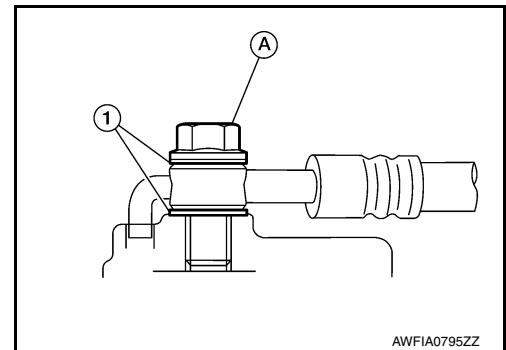

INSTALLATION

CAUTION:

Do not allow foreign matter (e.g. dust) and oils other than brake fluid to enter the reservoir tank.

1. Assemble the union bolt (A) and the copper sealing washers (1) to the brake hose and install it as an assembly to the brake caliper. Align the brake hose L-pin by aligning it with the brake caliper hole, and tighten the union bolt (A) to the specified torque.

CAUTION:

Do not reuse copper sealing washers.

2. Install the brake pipe to the brake hose, temporarily tighten the flare nut by hand until it does not rotate further, and attach the brake hose to the bracket with the lock plate.

CAUTION:

Check that the brake hoses and pipes are not bent or twisted.

3. Tighten the flare nut to the specified torque with a crowfoot and a torque wrench.

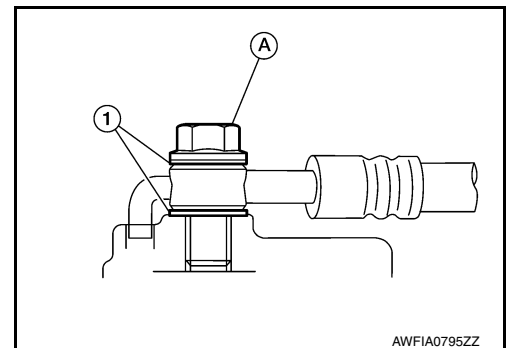

BRAKE PIPING

< REMOVAL AND INSTALLATION >

CAUTION:

Do not scratch the flare nut and the brake pipe.

4. Refill with new brake fluid and perform the air bleeding. Refer to [BR-14. "Bleeding Brake System"](#).

CAUTION:

Do not reuse drained brake fluid.

5. Install the wheels and tires. Refer to [WT-59. "Adjustment"](#).
6. Perform inspection after installation. Refer to [BR-8. "Inspection"](#).

A

B

C

D

E

BR

G

H

I

J

K

L

M

N

O

P

BRAKE MASTER CYLINDER

< REMOVAL AND INSTALLATION >

BRAKE MASTER CYLINDER

Exploded View

INFOID:000000012551754

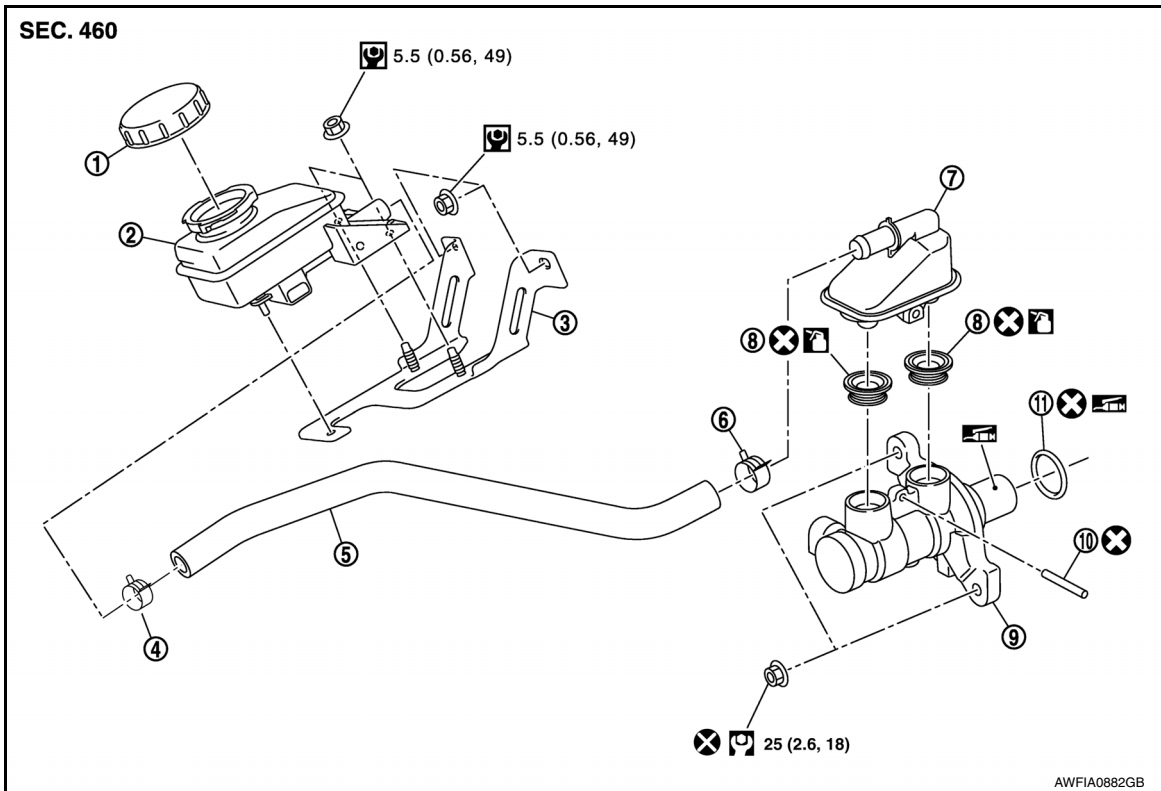

- | | | |
|-------------------|-------------|---------------------|
| 1. Sub tank cap | 2. Sub tank | 3. Sub tank bracket |
| 4. Clamp | 5. Hose | 6. Clamp |
| 7. Reservoir tank | 8. Grommet | 9. Cylinder body |
| 10. Pin | 11. O-ring | |

Apply PBC (Poly Butyl Cuprysil) grease or silicone-based grease.

Apply brake fluid.

Removal and Installation

INFOID:000000012551755

REMOVAL

CAUTION:

- Do not spill or splash brake fluid on painted areas; it may cause paint damage. If brake fluid is splashed on painted areas, wash it away with water immediately.
- Do not reuse master cylinder O-rings.
- Do not reuse drained brake fluid.

NOTE:

When removing components such as hoses, tubes/lines, etc., cap or plug openings to prevent fluid from spilling.

1. Disconnect the harness connector from the brake fluid level sensor.
2. Remove air duct assembly and air cleaner case. Refer to [EM-24, "Removal and Installation"](#).
3. Disconnect the hose from the reservoir tank.
4. Disconnect the brake pipes from the master cylinder assembly with a flare nut wrench.

CAUTION:

Do not scratch the flare nut or the brake pipe.

5. Remove the master cylinder assembly.

CAUTION:

BRAKE MASTER CYLINDER

< REMOVAL AND INSTALLATION >

Do not depress the brake pedal after the master cylinder assembly is removed.

INSTALLATION

CAUTION:

- Do not spill or splash brake fluid on painted areas; it may cause paint damage. If brake fluid is splashed on painted areas, wash it away with water immediately.
- Do not reuse O-ring.
- Do not reuse brake master cylinder nuts.

Installation is in the reverse order of removal.

- Apply PBC (Poly Butyl Cuprysil) silicone-based grease to the brake booster (A) when installing the master cylinder assembly to the brake booster.
- Temporarily tighten the brake tube flare nut to the master cylinder assembly by hand. Then tighten it to the specified torque with a crowfoot and torque wrench. Refer to [BR-22, "FRONT : Exploded View"](#).

CAUTION:

- Do not scratch the flare nut or the brake pipe.
- After installation, perform the air bleeding. Refer to [BR-14, "Bleeding Brake System"](#).

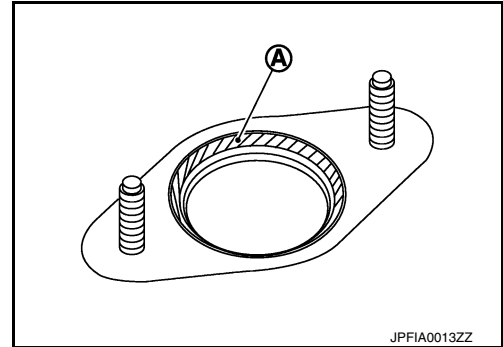

JPFIA0013ZZ

INFOID:000000012551756

Disassembly and Assembly

DISASSEMBLY

CAUTION:

- Do not disassemble the cylinder body.
- Remove the reservoir tank only when necessary.
- Do not drop removed parts. The parts must not be reused if they are dropped.

1. Secure the master cylinder assembly in a vise.

CAUTION:

Always use copper plates or cloth between vise and cylinder body. Do not overtighten the vise.

2. Remove the reservoir tank pin using suitable tools.

CAUTION:

Do not reuse the pin.

3. Remove the reservoir tank and grommets from the cylinder body. Discard the grommets.

CAUTION:

- Do not drop parts. Dropped parts must not be reused.
- Do not reuse the grommets.

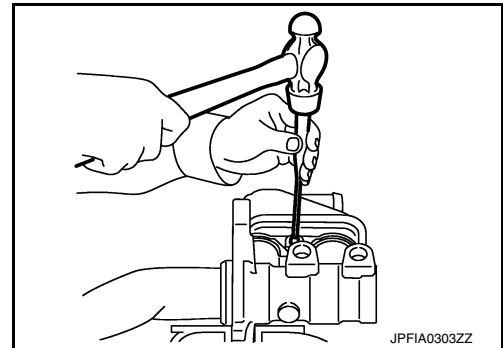

JPFIA0303ZZ

ASSEMBLY

1. Apply new brake fluid to the grommets and install them to the cylinder body.

CAUTION:

Do not use mineral oil such as gasoline or light oil.

2. Install the reservoir tank to the cylinder body.

CAUTION:

Do not drop the parts during installation. The parts must not be reused if they are dropped.

BRAKE MASTER CYLINDER

< REMOVAL AND INSTALLATION >

3. Tilt the reservoir tank so that the pin can be inserted. Insert a pin using suitable tools.

CAUTION:

Do not reuse the pin.

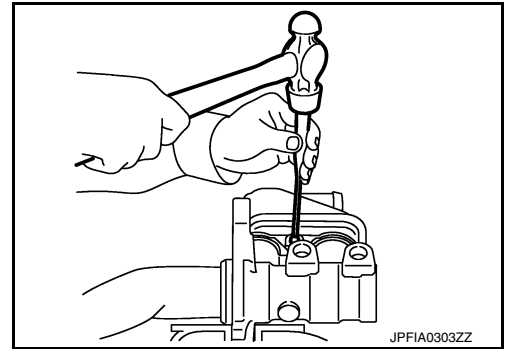

JPFIA0303ZZ

BRAKE BOOSTER

< REMOVAL AND INSTALLATION >

BRAKE BOOSTER

Exploded View

INFOID:000000012551757

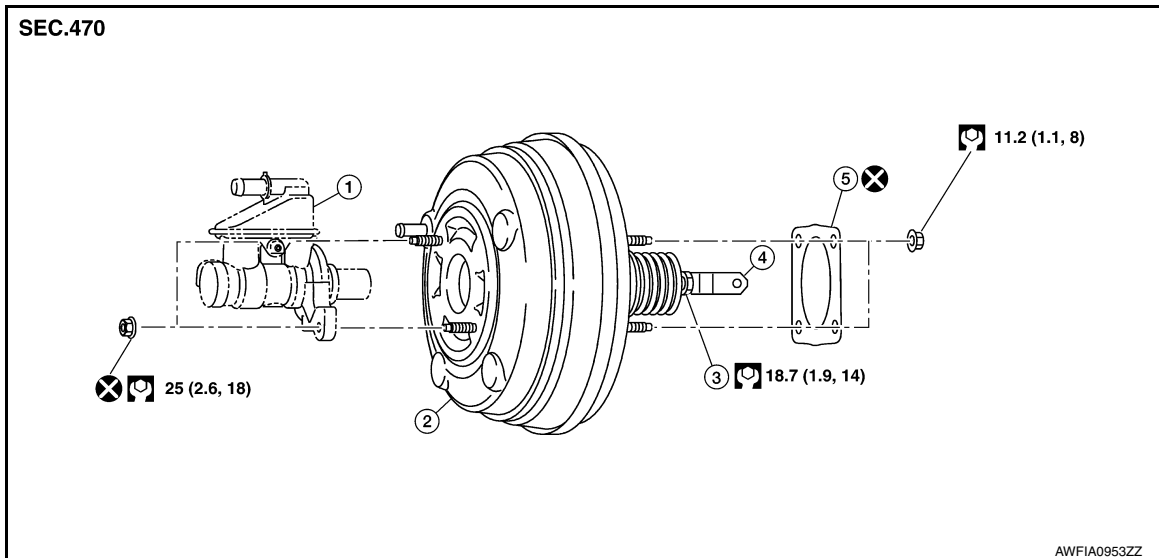

- | | | |
|-----------------------------|------------------|-------------|
| 1. Master cylinder assembly | 2. Brake booster | 3. Lock nut |
| 4. Clevis | 5. Gasket | |

Removal and Installation

INFOID:000000012551758

REMOVAL

1. Remove instrument lower panel LH. Refer to [IP-25, "Removal and Installation"](#).
2. Remove harness clip.
3. Remove the snap pin (1) and clevis pin (2) from the brake pedal.

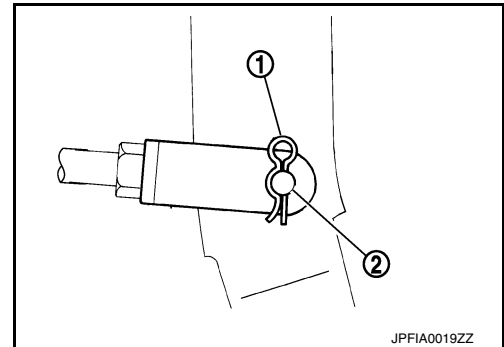

4. Remove the cowl top extension. Refer to [EXT-25, "Removal and Installation"](#).
5. Disconnect vacuum hose from brake booster. Refer to [BR-33, "Removal and Installation"](#).
6. Remove master cylinder assembly. Refer to [BR-28, "Removal and Installation"](#).
7. Disconnect the harness connector from the booster pressure sensor.
8. Disconnect the intelligent key warning buzzer from the strut tower and place aside.
9. Remove the four nuts on the brake booster and brake pedal assembly.
CAUTION:
Secure the brake booster to avoid damage to components.
10. Remove the brake booster from the dash panel on the engine room side.

CAUTION:

Do not deform or bend the brake pipes.

INSTALLATION

BRAKE BOOSTER

< REMOVAL AND INSTALLATION >

1. Loosen lock nut (1) and adjust input rod (2) to the specified length (B).

Length (B) : Refer to [BR-31, "Removal and Installation"](#).

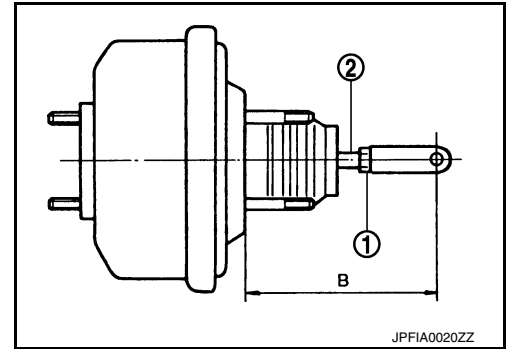

2. After adjustment, temporarily tighten lock nut to install booster assembly.
3. Install a new gasket between the brake booster and dash panel.
CAUTION:
Do not reuse the gasket.
4. Install the brake booster to the dash panel from the engine room side.
CAUTION:
Do not damage brake booster stud bolt threads during installation.
5. Install the four nuts to the brake booster and brake pedal assembly. Refer to [BR-31, "Exploded View"](#).
6. Install the intelligent key warning buzzer to the strut tower.
7. Connect the harness connector to the booster pressure sensor.
8. Install master cylinder assembly. Refer to [BR-28, "Removal and Installation"](#).
9. Connect vacuum hose to brake booster. Refer to [BR-33, "Exploded View"](#).
10. Install the cowl top extension. Refer to [EXT-25, "Removal and Installation"](#).
11. Install the clevis pin and snap pin to the brake pedal.
12. Install the harness clip.
13. Adjust the brake pedal. Refer to [BR-13, "Adjustment"](#).
14. Install instrument lower panel LH. Refer to [IP-25, "Removal and Installation"](#).
15. Bleed the brake system. Refer to [BR-14, "Bleeding Brake System"](#).
16. Inspect the brake booster. Refer to [BR-10, "Inspection"](#).

VACUUM LINES

< REMOVAL AND INSTALLATION >

VACUUM LINES

Exploded View

INFOID:000000012551759

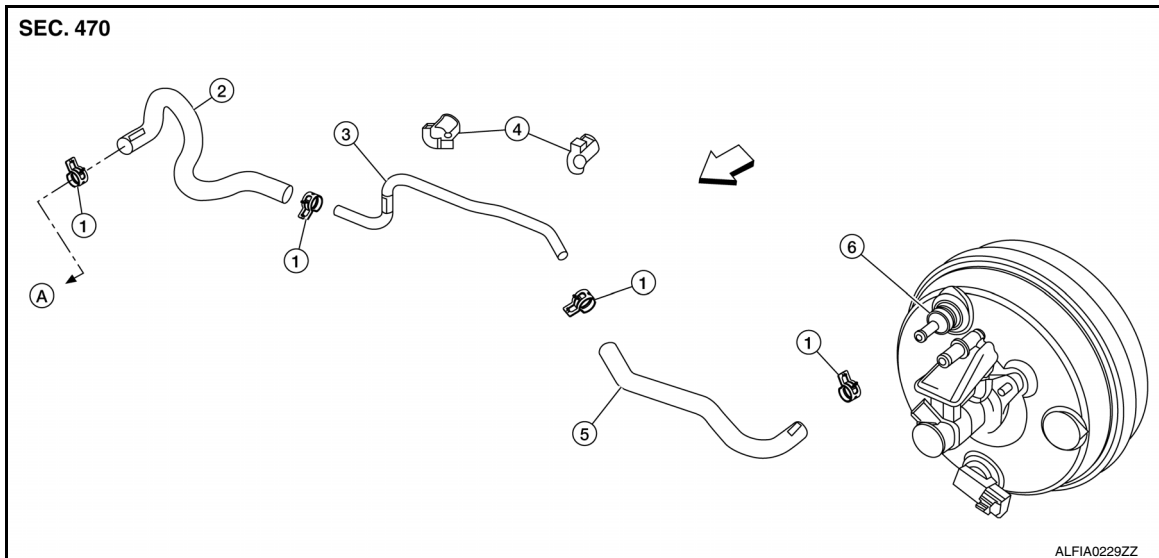

- | | | |
|-----------------------|----------------|----------------|
| 1. Clamp | 2. Vacuum hose | 3. Vacuum pipe |
| 4. Clip | 5. Vacuum hose | 6. Check valve |
| A. To intake manifold | ↔ Front | |

Removal and Installation

INFOID:000000012551760

REMOVAL

1. Remove engine room cover and front air duct Refer to [EM-24, "Removal and Installation"](#).
2. Disconnect the vacuum hose from the brake booster.
3. Disconnect the vacuum hose from the engine intake manifold.
4. Disconnect clips from vacuum pipe.
5. Remove the vacuum hose assembly.

INSPECTION AFTER REMOVAL

Visual Inspection

Check for correct installation, damage and deterioration of the vacuum hoses and pipe.

Valve Air-tightness Check

- Connect a suitable tool at each end of the vacuum hose to inspect the check valve operation.

Vacuum applied at booster end : Refer to [BR-50, "Check Valve"](#).

Vacuum applied at intake manifold end : Refer to [BR-50, "Check Valve"](#).

- Replace the vacuum hose with check valve if out of specification.

INSTALLATION

Installation is in the reverse order of removal.

CAUTION:

VACUUM LINES

< REMOVAL AND INSTALLATION >

- Because the vacuum hose contains a check valve, the vacuum hose must be installed in the correct position for proper operation. Refer to the stamp on the end of the vacuum hose to confirm correct installation. The brake booster will not operate normally if the vacuum hose with the check valve is installed in the wrong direction.
- Insert the vacuum pipe into the vacuum hose at least 24 mm (0.94 in) as shown.
- Do not use lubricating oil during installation.

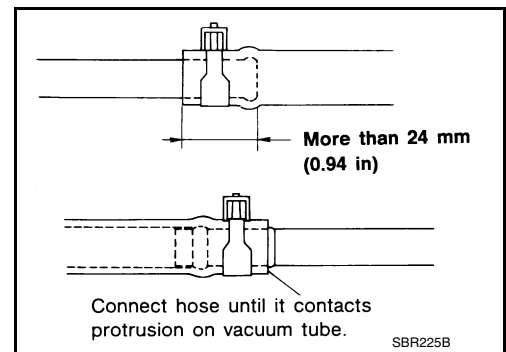

FRONT DISC BRAKE

< REMOVAL AND INSTALLATION >

FRONT DISC BRAKE

BRAKE PAD

BRAKE PAD : Exploded View

INFOID:000000012551761

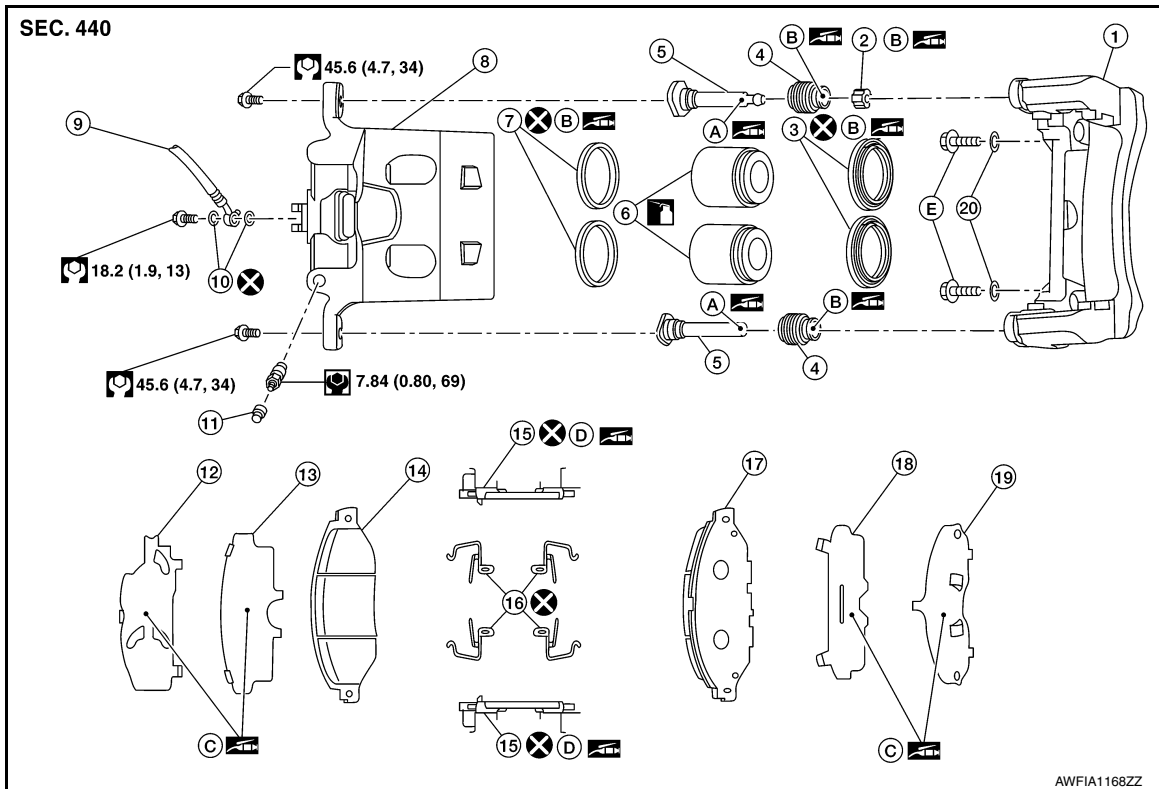

- | | | |
|--|-----------------------------------|----------------------|
| 1. Torque member | 2. Bushing | 3. Piston boot |
| 4. Slide pin boot | 5. Slide pin | 6. Piston |
| 7. Piston seal | 8. Brake caliper body | 9. Brake hose |
| 10. Copper sealing washers | 11. Bleeder cap | 12. Inner shim cover |
| 13. Inner shim | 14. Inner pad | 15. Pad retainer |
| 16. Anti-rattle clip | 17. Outer pad | 18. Outer shim |
| 19. Outer shim cover | 20. Washers (without flange bolt) | A. Nigrove Rx-2 |
| B. Rubber grease | C. Molykote AS-880N | D. Molykote 7439 |
| E. Refer to FRONT CALIPER INSTALLATION | | |

: Apply brake fluid.

BRAKE PAD : Removal and Installation

INFOID:000000012551762

REMOVAL

WARNING:

Clean dust on brake caliper and brake pad with a vacuum dust collector to minimize the hazards of airborne particles or other material.

CAUTION:

- Do not depress the brake pedal while removing the brake pads because the pistons may pop out.
- It is not necessary to remove bolts on torque member and brake hose except for disassembly or replacement of brake caliper. For brake pad removal, hang brake caliper with a wire so as not to stretch brake hose.
- If brake fluid or grease adheres to the brake caliper or disc brake rotor, quickly wipe it off.
- Do not reuse drained brake fluid.

FRONT DISC BRAKE

< REMOVAL AND INSTALLATION >

1. Observe brake fluid level in the sub tank. Partially drain brake fluid if necessary. Refer to [BR-14. "Drain and Refill"](#).
2. Remove the front wheels and tires using power tool.
3. Remove slide pin bolts.
4. Remove the brake caliper from the torque member. Leaving brake hose attached, reposition the brake caliper aside with wire.
5. Remove the brake pads, shims, shim covers, pad retainers, and anti-rattle clips from the torque member.
CAUTION:
 - Do not reuse the pad retainers and anti-rattle clips.
 - Do not damage the piston boot.
 - Do not drop the brake pads, shims, or the shim covers.
 - Note the position of components during removal to aid with installation.
6. Compress the front caliper pistons.

INSTALLATION

1. Apply Molykote® 7439 to inner and outer surfaces of the brake pad retainers.
2. Install the new pad retainers and anti-rattle clips to the torque member.
CAUTION:
 - Do not reuse the pad retainers and anti-rattle clips.
 - Do not deform the pad retainers.
 - Verify that the pad retainers are secured properly to the torque member.
3. Apply Molykote® AS-880N grease to the mating faces between the inner shim, inner shim cover, outer shim and outer shim cover and install them to the brake pad. Refer to [BR-35. "BRAKE PAD : Exploded View"](#).
CAUTION:
When installing new brake pads, replace the shims and shim covers.
4. Install the brake pads to the torque member.
5. Using a suitable tool, press the pistons into the brake caliper.
CAUTION:
Do not damage the piston boot.
6. Install the brake caliper to the torque member.
7. Install the slide pin bolts and tighten to specification. Refer to [BR-35. "BRAKE PAD : Exploded View"](#).
8. Depress the brake pedal several times and verify that drag does not exist.
9. Install the front wheels and tires. Refer to [WT-59. "Adjustment"](#).
10. Check brake fluid level and refill as necessary. Refer to [BR-8. "Inspection"](#).

INSPECTION AFTER INSTALLATION

1. Check the drag of front disc brake. If any drag is found, follow the procedure described below.
2. Remove brake pads.
3. Using a suitable tool, press the pistons into the brake caliper body.
CAUTION:
Do not damage the piston boots.
4. Install brake pads.
5. Depress the brake pedal several times.
6. Check the drag of front disc brake again. If any drag is found, disassemble the brake caliper body.
7. Burnish contact surfaces after refinishing or replacing disc brake rotors or if a soft pedal occurs at very low mileage. Refer to [BR-16. "BRAKE PAD : Inspection"](#).

BRAKE CALIPER ASSEMBLY

BRAKE CALIPER ASSEMBLY : Exploded View

INFOID:000000012551763

FRONT DISC BRAKE

< REMOVAL AND INSTALLATION >

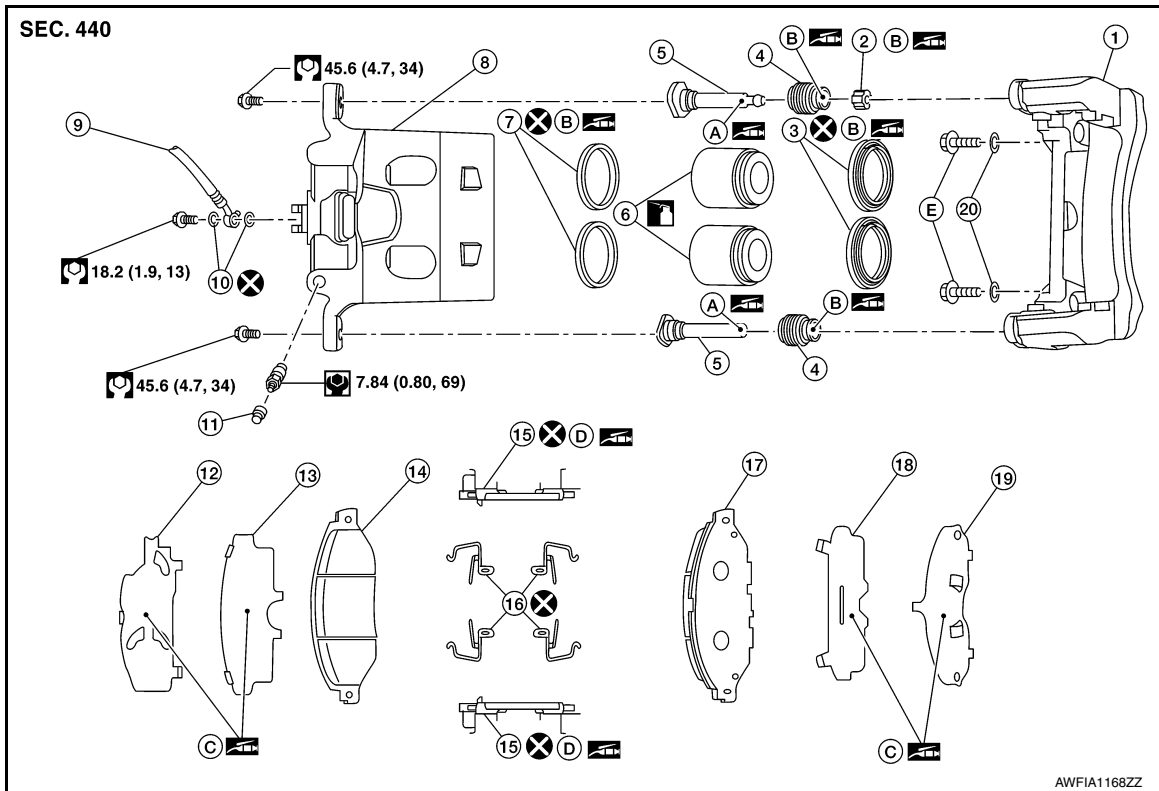

- | | | |
|----------------------------|-----------------------------------|----------------------|
| 1. Torque member | 2. Bushing | 3. Piston boot |
| 4. Slide pin boot | 5. Slide pin | 6. Piston |
| 7. Piston seal | 8. Brake caliper body | 9. Brake hose |
| 10. Copper sealing washers | 11. Bleeder cap | 12. Inner shim cover |
| 13. Inner shim | 14. Inner pad | 15. Pad retainer |
| 16. Anti-rattle clip | 17. Outer pad | 18. Outer shim |
| 19. Outer shim cover | 20. Washers (without flange bolt) | A. Nigrove Rx-2 |
| B. Rubber grease | C. Molykote AS-880N | D. Molykote 7439 |
| E. Refer to INSTALLATION | | |

: Apply brake fluid.

BRAKE CALIPER ASSEMBLY : Removal and Installation

INFOID:000000012551764

WARNING:

Clean dust on brake caliper and brake pad with a vacuum dust collector to minimize the hazard of airborne particles or other materials.

CAUTION:

- Do not depress the brake pedal.
- Do not spill or splash brake fluid on painted areas; it may cause paint damage. If brake fluid is splashed on painted areas, wash it away with water immediately.
- Do not bend, twist or pull the brake hoses and piping.
- Do not reuse drained brake fluid.

NOTE:

When removing components such as hoses, tubes/lines, etc., cap or plug openings to prevent fluid from spilling.

REMOVAL

1. Remove reservoir cap from the reservoir tank.
2. Remove front wheels and tires using power tool.
3. Secure the disc brake rotor using wheel nuts.

FRONT DISC BRAKE

< REMOVAL AND INSTALLATION >

4. Remove union bolt, copper sealing washers, and disconnect brake hose from brake caliper. Discard the copper sealing washers.

CAUTION:

Do not reuse copper sealing washers.

5. Remove slide pin bolts and the brake caliper.

CAUTION:

Do not drop brake pads or caliper.

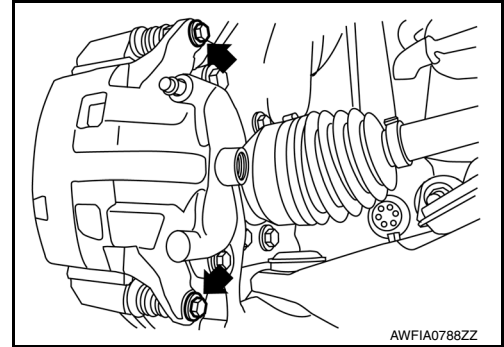

6. Remove the brake pads from the torque member.

CAUTION:

- Do not damage the piston boot.
- Do not drop the brake pads, shims, or the shim covers.
- Note the position of components during removal to aid with installation.

7. If necessary, remove torque member bolts and the torque member.

NOTE:

Torque member bolt style may differ between flange bolt and bolt with washer.

INSTALLATION

1. If necessary, install the torque member bolts and the torque member.

Torque member flange bolt: 123 N·m (13 kg·m, 91 ft·lb)

Torque member bolt with washer: 144.5 N·m (15 kg·m, 107 ft·lb)

2. Install the brake pads in the torque member.

CAUTION:

- Do not damage the piston boot.
- Do not drop the brake pads, shims, or the shim covers.

3. Position the brake caliper to torque member and install the slide pin bolts. Tighten to specification.

4. Assemble the union bolt (A) and the copper sealing washers (1) to the brake hose and install it as an assembly to the brake caliper. Align the brake hose L-pin by aligning it with the brake caliper hole, and tighten the union bolt (1) to the specified torque.

CAUTION:

Do not reuse copper sealing washers.

5. Refill with new brake fluid and perform the air bleeding. Refer to [BR-14. "Bleeding Brake System"](#).

CAUTION:

- Do not reuse drained brake fluid.
- Do not spill or splash brake fluid on the disc brake rotor.

6. Install the front wheels and tires. Refer to [WT-59. "Adjustment"](#).

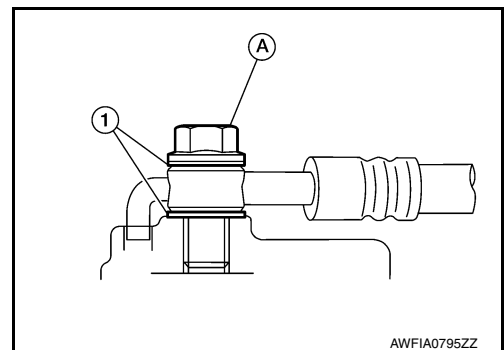

INSPECTION AFTER INSTALLATION

1. Check the drag of front disc brake. If any drag is found, follow the procedure described below.

2. Remove brake pads.

3. Using a suitable tool, press the pistons into the brake caliper body.

CAUTION:

Do not damage the piston boots.

4. Install brake pads.

5. Depress the brake pedal several times.

6. Check the drag of front disc brake again. If any drag is found, disassemble the brake caliper body.

FRONT DISC BRAKE

< REMOVAL AND INSTALLATION >

7. Burnish contact surfaces after refinishing or replacing disc brake rotors or if a soft pedal occurs at very low mileage. Refer to [BR-16, "BRAKE PAD : Inspection"](#).

A

B

C

D

E

BR

G

H

I

J

K

L

M

N

O

P

REAR DISC BRAKE

< REMOVAL AND INSTALLATION >

REAR DISC BRAKE

BRAKE PAD

BRAKE PAD : Exploded View

INFOID:000000012551765

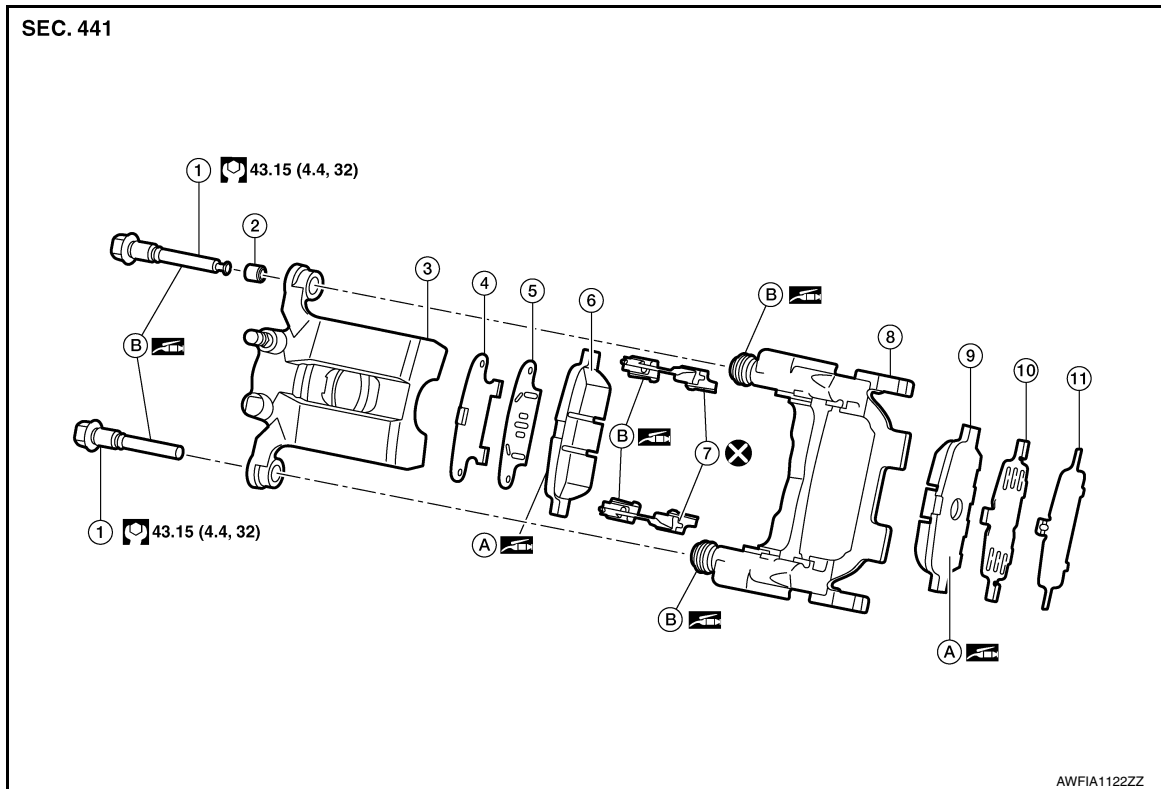

- | | | |
|---------------------|------------------------|------------------|
| 1. Sliding pin bolt | 2. Sliding pin bushing | 3. Cylinder body |
| 4. Inner shim cover | 5. Inner shim | 6. Inner pad |
| 7. Pad retainer | 8. Torque member | 9. Outer pad |
| 10. Outer shim | 11. Outer shim cover | |
| A. Molykote AS-880N | B. Rubber grease | |

BRAKE PAD : Removal and Installation

INFOID:000000012551766

REMOVAL

WARNING:

Clean dust on brake caliper and brake pad with a vacuum dust collector to minimize the hazards of airborne particles or other material.

CAUTION:

- Do not depress the brake pedal while removing the brake pads because the pistons may pop out.
- It is not necessary to remove bolts on torque member and brake hose except for disassembly or replacement of brake caliper. For brake pad removal, hang brake caliper with a wire so as not to stretch brake hose.
- If brake fluid or grease adheres to the brake caliper or disc brake rotor, quickly wipe it off.

1. Partially drain brake fluid from the master cylinder. Refer to [BR-14. "Drain and Refill"](#).
2. Remove the rear wheels and tires using power tool. Refer to [WT-59. "Adjustment"](#).
3. Loosen the lower sliding pin bolt and remove the upper sliding pin bolt.
4. Using the lower sliding pin bolt as a pivot, swing the brake caliper down from the torque member. Leaving the brake hose attached, support the brake caliper with wire.
5. Remove the brake pads, shims, shim covers and pad retainers from the torque member.

CAUTION:

REAR DISC BRAKE

< REMOVAL AND INSTALLATION >

- Do not reuse the pad retainers.
- Do not damage the piston boot.
- Do not drop the brake pads, shims, or the shim covers.
- Note the position of components during removal to aid with installation.

INSTALLATION

1. Install the new pad retainers to the torque member.
CAUTION:
 - Do not reuse the pad retainers.
 - Do not deform the pad retainers.
 - Verify that the pad retainers are secured properly to the torque member.
2. Apply rubber grease or equivalent to the mating faces between the brake pads and pad retainers. Refer to [BR-35, "BRAKE PAD : Exploded View"](#).
3. Apply Molykote AS-880N grease or equivalent to the mating faces between the brake pads, shims and shim covers. Install components to the brake pad. Refer to [BR-35, "BRAKE PAD : Exploded View"](#).
CAUTION:
When installing new brake pads, replace the shims and shim covers.
4. Install the brake pads to the torque member.
5. Using a suitable tool, press the pistons into the brake caliper.
CAUTION:
Do not damage the piston boot.
6. Using the lower sliding pin bolt as a pivot, swing the brake caliper up to the torque member.
7. Install the upper sliding pin bolts. Tighten all sliding pin bolts to specification. Refer to [BR-35, "BRAKE PAD : Exploded View"](#).
8. Depress the brake pedal several times and verify that drag does not exist.
9. Install the front wheels and tires. Refer to [WT-59, "Adjustment"](#).
10. Check brake fluid level and refill as necessary. Refer to [BR-8, "Inspection"](#).

BRAKE CALIPER ASSEMBLY

BRAKE CALIPER ASSEMBLY : Exploded View

INFOID:000000012551767

REAR DISC BRAKE

< REMOVAL AND INSTALLATION >

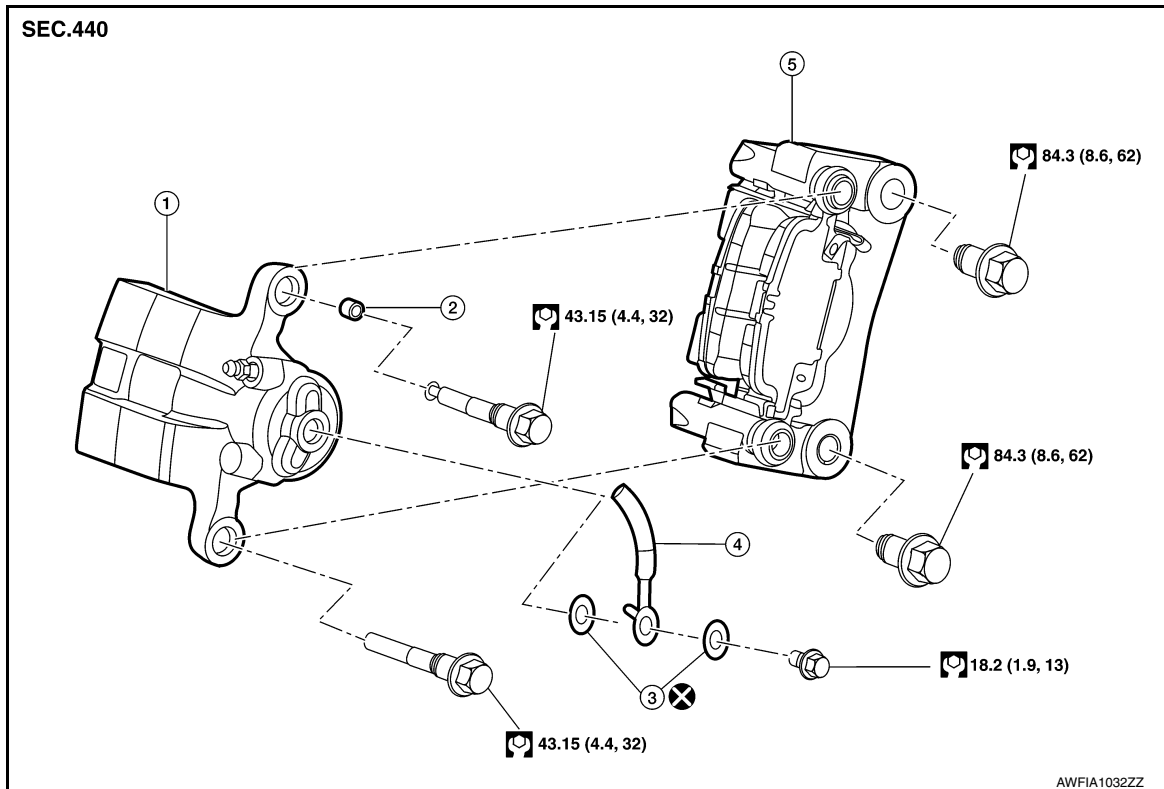

- | | | |
|------------------|-----------------------------|--------------------------|
| 1. Brake caliper | 2. Sliding pin bolt bushing | 3. Copper sealing washer |
| 4. Brake hose | 5. Torque member | |

BRAKE CALIPER ASSEMBLY : Removal and Installation

INFOID:000000012551768

WARNING:

Clean dust on brake caliper and brake pad with a vacuum dust collector to minimize the hazard of airborne particles or other materials.

CAUTION:

- Do not depress the brake pedal.
- Do not spill or splash brake fluid on painted areas; it may cause paint damage. If brake fluid is splashed on painted areas, wash it away with water immediately.
- Do not bend, twist or pull the brake hoses and piping.
- Do not reuse drained brake fluid.

NOTE:

When removing components such as hoses, tubes/lines, etc., cap or plug openings to prevent fluid from spilling.

REMOVAL

1. Remove rear wheels and tires using power tool. Refer to [WT-59, "Adjustment"](#).
2. Secure the disc brake rotor using wheel nuts.
3. Remove union bolt, copper sealing washers, and disconnect brake hose from brake caliper. Discard the copper sealing washers.

CAUTION:

Do not reuse copper sealing washers.

4. Remove the torque member bolts. Remove the brake caliper and torque member from the vehicle as an assembly.
5. Remove sliding pin bolts and the brake caliper from torque member.

CAUTION:

Do not drop brake pads or brake caliper.

INSTALLATION

REAR DISC BRAKE

< REMOVAL AND INSTALLATION >

1. Install the brake caliper to torque member and install the sliding pin bolts. Tighten to specification.
2. Install the brake caliper and torque member to the vehicle as an assembly. Install the torque member bolts.
3. Assemble the union bolt (A) and the copper sealing washers (1) to the brake hose and install it as an assembly to the brake caliper. Align the brake hose L-pin by aligning it with the brake caliper hole, and tighten the union bolt (A) to the specified torque.
CAUTION:
Do not reuse copper sealing washers.
4. Refill with new brake fluid and perform the air bleeding. Refer to [BR-14, "Bleeding Brake System"](#).
CAUTION:
 - Do not reuse drained brake fluid.
 - Do not spill or splash brake fluid on the disc brake rotor.
5. Check the rear disc brakes for drag.
6. Install the rear wheels and tires. Refer to [WT-59, "Adjustment"](#).

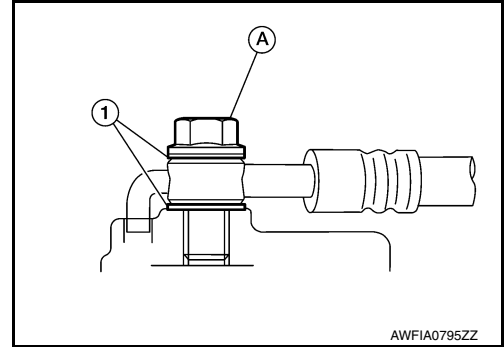

A
B
C
D
E
G
H
I
J
K
L
M
N
O
P

BR

FRONT DISC BRAKE

< UNIT DISASSEMBLY AND ASSEMBLY >

UNIT DISASSEMBLY AND ASSEMBLY

FRONT DISC BRAKE

Exploded View

INFOID:0000000012551769

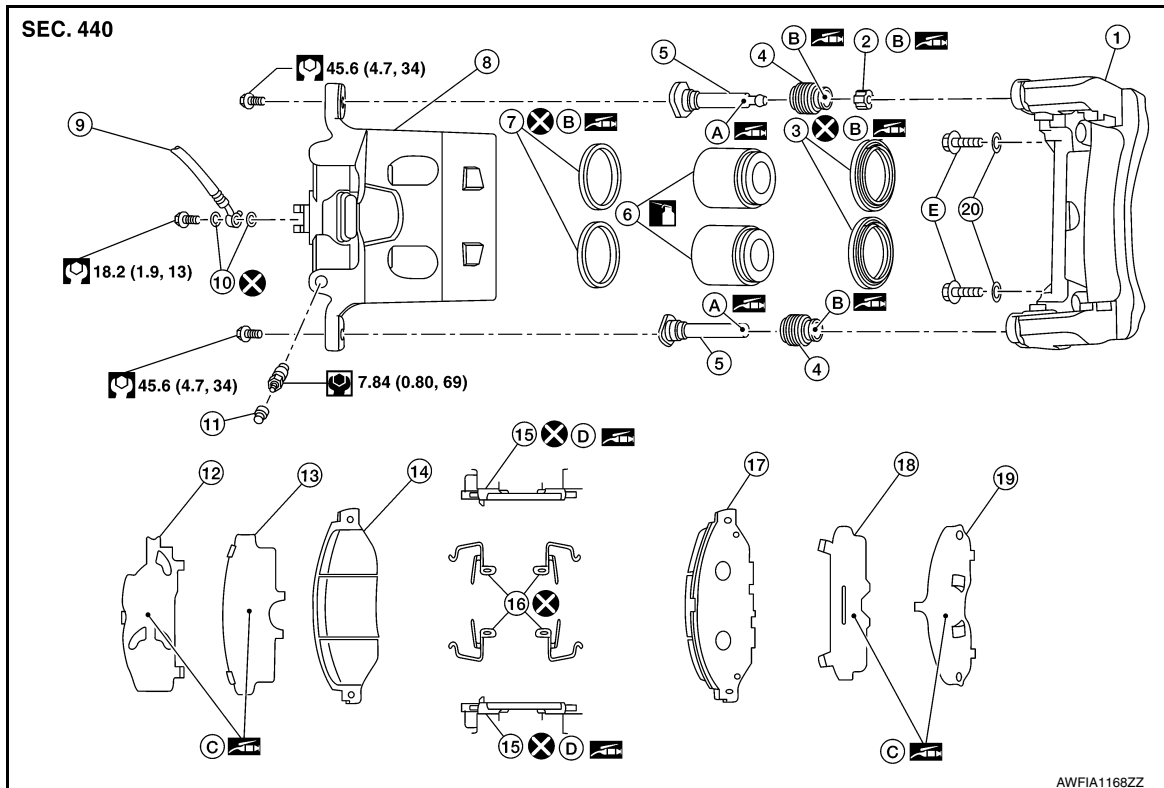

- | | | |
|--|-----------------------------------|----------------------|
| 1. Torque member | 2. Bushing | 3. Piston boot |
| 4. Slide pin boot | 5. Slide pin | 6. Piston |
| 7. Piston seal | 8. Brake caliper body | 9. Brake hose |
| 10. Copper sealing washers | 11. Bleeder cap | 12. Inner shim cover |
| 13. Inner shim | 14. Inner pad | 15. Pad retainer |
| 16. Anti-rattle clip | 17. Outer pad | 18. Outer shim |
| 19. Outer shim cover | 20. Washers (without flange bolt) | A. Nigrove Rx-2 |
| B. Rubber grease | C. Molykote AS-880N | D. Molykote 7439 |
| E. Refer to FRONT CALIPER INSTALLATION | | |

: Apply brake fluid.

Disassembly and Assembly

INFOID:0000000012551770

DISASSEMBLY

1. Remove the brake caliper from the vehicle. Refer to [BR-37, "BRAKE CALIPER ASSEMBLY : Removal and Installation"](#).
2. Remove slide pins and slide pin boots from torque member.

FRONT DISC BRAKE

< UNIT DISASSEMBLY AND ASSEMBLY >

- Place a wooden block in brake caliper body and blow air from union bolt hole to remove pistons and piston boots.

WARNING:

Do not get fingers caught between pistons and brake caliper body.

CAUTION:

Do not reuse piston boots.

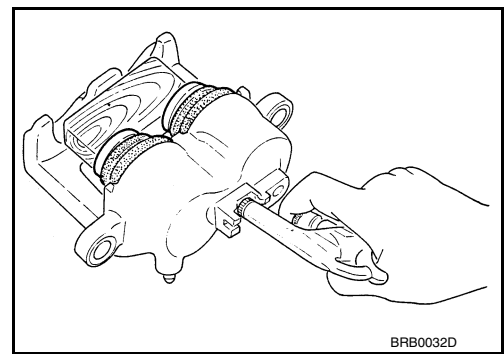

- Remove piston seals from brake caliper body using suitable tool.

CAUTION:

- Do not damage cylinder inner wall.
- Do not reuse piston seals.

- Remove bleeder valve and cap.

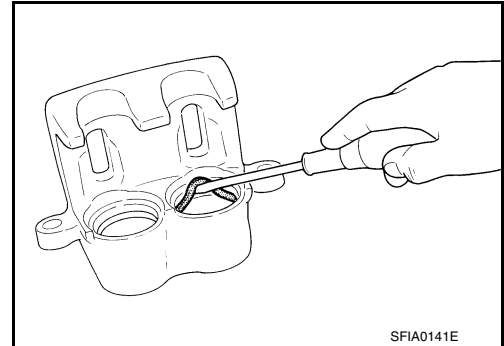

INSPECTION AFTER DISASSEMBLY

Brake Caliper Body

Check the inner wall of the brake caliper body for rust, wear, cracks or damage. Replace the brake caliper body if any abnormal condition is detected.

CAUTION:

Always clean with new brake fluid. Do not clean with mineral oil such as gasoline and light oil.

Torque Member

Check the torque member for rust, wear, cracks or damage. Replace the torque member if any abnormal condition is detected.

Piston

Check the surface of the piston for rust, wear, cracks or damage. Replace the piston if any abnormal condition is detected.

CAUTION:

Piston sliding surface is plated. Do not polish with sandpaper.

Slide Pin and Slide Pin Boot

Check the slide pins and slide pin boots for rust, wear, cracks or damage. Replace the parts if any abnormal condition is detected.

ASSEMBLY

- Install bleeder valve and cap.
- Apply rubber grease to each piston seal (1), and install them to the brake caliper body.

CAUTION:

Do not reuse piston seal.

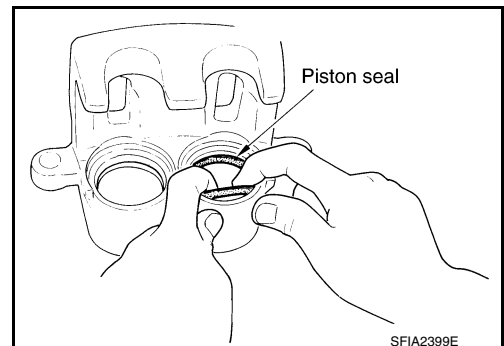

A
B
C
D
E
BR
G
H
I
J
K
L
M
N
O
P

FRONT DISC BRAKE

< UNIT DISASSEMBLY AND ASSEMBLY >

3. Apply rubber grease to the piston boots. Cover each piston end with a piston boot, and then install cylinder side lip on piston boot securely into a groove on brake caliper body.

CAUTION:

Do not reuse piston boots.

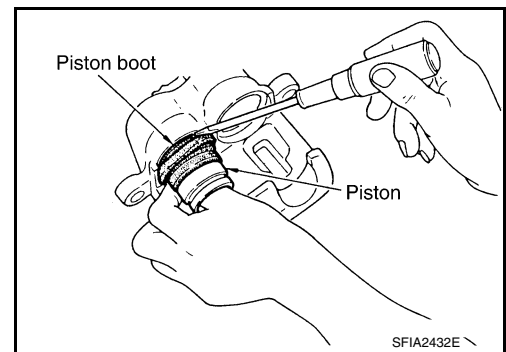

4. Apply brake fluid to each piston (1). Push each piston into cylinder body by hand and push piston boot (2) piston-side lip into the piston groove.

CAUTION:

Press the piston evenly and vary the pressing point to prevent cylinder inner wall from being rubbed.

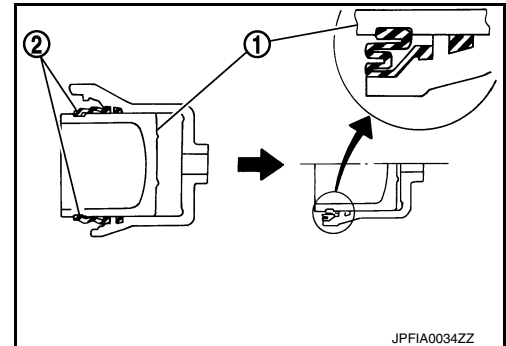

5. Apply rubber grease to bushing; install bushing to slide pin.
6. Apply Nigrove Rx-2 to slide pins.
7. Apply rubber grease to slide pin boots, install slide pins and slide pin boots to torque member.
8. Install the brake caliper to the vehicle. Refer to [BR-37, "BRAKE CALIPER ASSEMBLY : Removal and Installation"](#).

INSPECTION AFTER INSTALLATION

1. Check the drag of front disc brake. If any drag is found, follow the procedure described below.
2. Remove brake pads.
3. Using a suitable tool, press the pistons into the brake caliper body.
CAUTION:
Do not damage the piston boots.
4. Install brake pads.
5. Depress the brake pedal several times.
6. Check the drag of front disc brake again. If any drag is found, disassemble the brake caliper body.
7. Burnish contact surfaces after refinishing or replacing disc brake rotors or if a soft pedal occurs at very low mileage. Refer to [BR-16, "BRAKE PAD : Inspection"](#).

REAR DISC BRAKE

< UNIT DISASSEMBLY AND ASSEMBLY >

REAR DISC BRAKE

Exploded View

INFOID:000000012551771

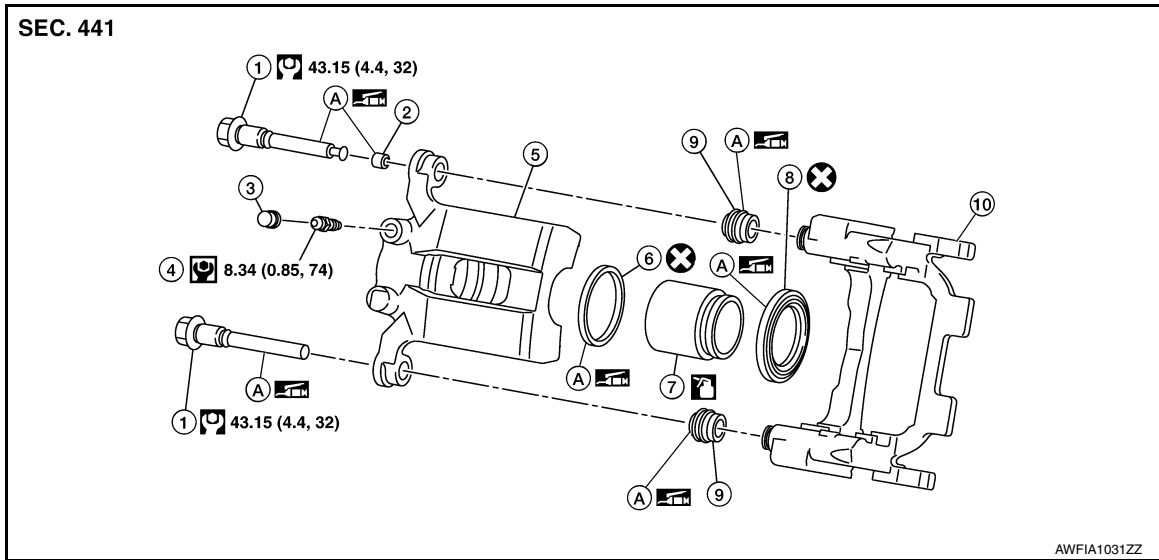

- | | | |
|---------------------|-----------------------------|---------------------|
| 1. Sliding pin bolt | 2. Sliding pin bolt bushing | 3. Cap |
| 4. Bleeder valve | 5. Brake caliper body | 6. Piston seal |
| 7. Piston | 8. Piston boot | 9. Sliding pin boot |
| 10. Torque member | | |
- A. Rubber grease
 Apply brake fluid

Disassembly and Assembly

INFOID:000000012551772

DISASSEMBLY

1. Remove the brake caliper from the vehicle. Refer to [BR-42, "BRAKE CALIPER ASSEMBLY : Removal and Installation"](#).
2. Remove sliding pin boots from torque member.
3. Remove sliding pin bolt bushing from sliding pin bolt.
4. Place a wooden block in the cylinder body and blow air from union bolt hole to remove piston and piston boot.

WARNING:

Do not get fingers caught between pistons and brake caliper body.

CAUTION:

Do not reuse piston boot.

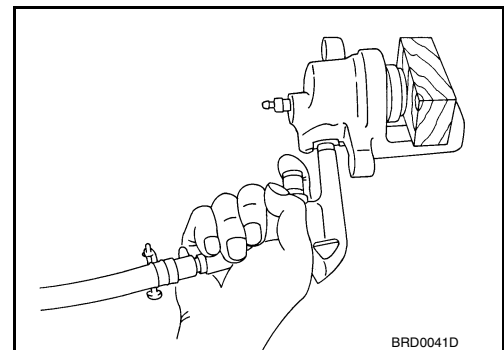

REAR DISC BRAKE

< UNIT DISASSEMBLY AND ASSEMBLY >

5. Remove piston seal from brake caliper body using suitable tool.

CAUTION:

- Do not damage cylinder inner wall.
- Do not reuse piston seal.

6. Remove bleeder valve and cap.

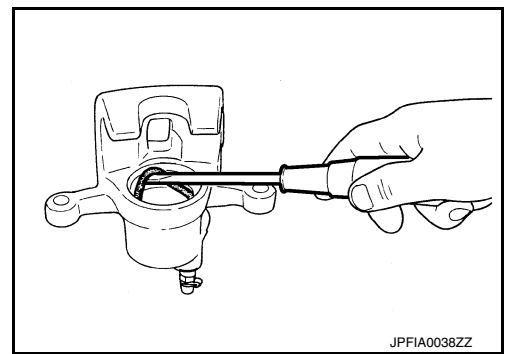

INSPECTION AFTER DISASSEMBLY

Brake Caliper Body

Check the inner wall of the brake caliper body for rust, wear, cracks or damage. Replace the brake caliper body if any abnormal condition is detected.

CAUTION:

Always clean with new brake fluid. Do not clean with mineral oil such as gasoline and light oil.

Torque Member

Check the torque member for rust, wear, cracks or damage. Replace the torque member if any abnormal condition is detected.

Piston

Check the surface of the piston for rust, wear, cracks or damage. Replace the piston if any abnormal condition is detected.

CAUTION:

Piston sliding surface is plated. Do not polish with sandpaper.

Sliding Pin and Sliding Pin Bolt Boot

Check the sliding pins and sliding pin bolt boots for rust, wear, cracks or damage. Replace the parts if any abnormal condition is detected.

ASSEMBLY

1. Install bleeder valve and cap.
2. Apply rubber grease to piston seal (1), and install it to the brake caliper body.

CAUTION:

Do not reuse piston seal.

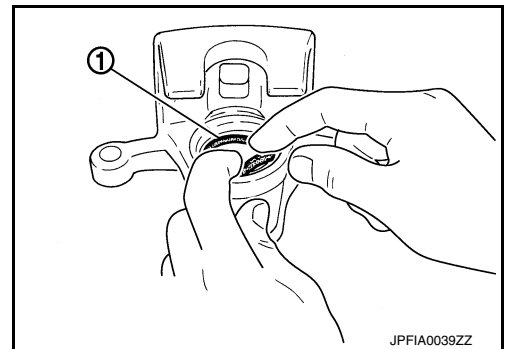

3. Apply rubber grease to piston boot (1). Cover the piston (2) end with the piston boot, and then install cylinder side lip on the piston boot securely into the groove on brake caliper body.

CAUTION:

Do not reuse piston boot.

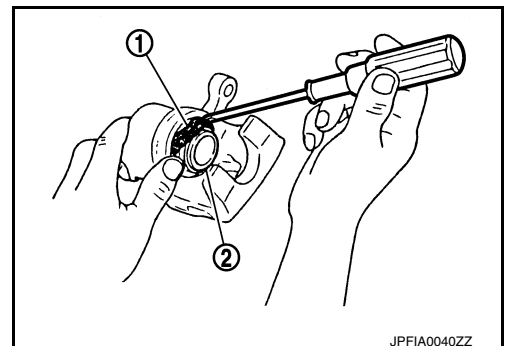

REAR DISC BRAKE

< UNIT DISASSEMBLY AND ASSEMBLY >

4. Apply brake fluid to piston (1). Push piston into brake caliper body by hand and push piston boot (2) piston side lip into the piston groove.

CAUTION:

Press the piston evenly and vary the pressing point to prevent cylinder inner wall from contact.

5. Apply rubber grease to bushing; install bushing to sliding pin bolt.
6. Install sliding pin boots to torque member.
7. Install the brake caliper to the vehicle. Refer to [BR-42. "BRAKE CALIPER ASSEMBLY : Removal and Installation"](#).

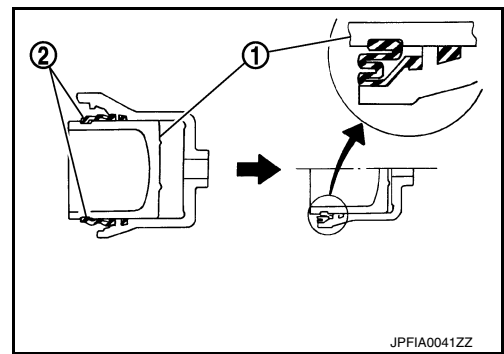

INSPECTION AFTER INSTALLATION

1. Check the drag of rear disc brake. If any drag is found, follow the procedure described below.
2. Remove brake pads.
3. Using a suitable tool, press the pistons into the brake caliper body.
CAUTION:
Do not damage the piston boots.
4. Install brake pads.
5. Depress the brake pedal several times.
6. Check the drag of rear disc brake again. If any drag is found, disassemble the brake caliper body.
7. Burnish contact surfaces after refinishing or replacing disc rotors or if a soft pedal occurs at very low mileage. Refer to [BR-18. "BRAKE PAD : Inspection"](#).

A
B
C
D
E
G
H
I
J
K
L
M
N
O
P

BR

SERVICE DATA AND SPECIFICATIONS (SDS)

< SERVICE DATA AND SPECIFICATIONS (SDS)

SERVICE DATA AND SPECIFICATIONS (SDS)

SERVICE DATA AND SPECIFICATIONS (SDS)

General Specifications

INFOID:0000000012551773

Unit: mm (in)

Front brake	Cylinder bore diameter	45.0 (1.772) × 2
	Pad length × width × thickness	131.4 (5.173) × 53.0 (2.087) × 10.0 (0.394)
	Disc rotor outer diameter × thickness	320.0 (12.598) × 28.0 (1.102)
Rear brake	Cylinder bore diameter	42.86 (1.6874)
	Pad length × width × thickness	83.0 (3.268) × 33.0 (1.299) × 8.5 (0.335)
	Disc rotor outer diameter × thickness	308 (12.126) × 16.0 (0.630)
Master cylinder	Cylinder bore diameter	26.99 (1.063)
Control valve	Valve type	Electric brake force distribution
Recommended brake fluid		Refer to MA-17. "FOR USA AND CANADA : Fluids and Lubricants" (United States and Canada) or MA-19. "FOR MEXICO : Fluids and Lubricants" (Mexico).

Brake Pedal

INFOID:0000000012551774

Unit: mm (in)

Item	Standard
Brake pedal height (H1)	214.2 – 224.2 (8.43 – 8.82)
Clearance (A) between brake pedal bracket, stop lamp switch and brake pedal position switch contact ends	0.74 – 1.96 (0.0291 – 0.0772)
Brake pedal full stroke (H2)	139.1 (5.476)
Depressed brake pedal height (H3) [Depressing 490 N (50 kg, 110 lb) while turning the engine ON]	75.1 (2.96)

Check Valve

INFOID:0000000012551775

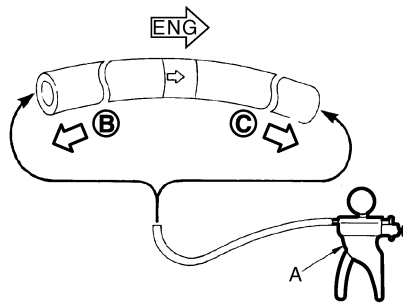

JPFIA0024ZZ

When suitable tool (A) is connected to booster side (B)	3.3 kPa (25 mmHg, 0.98 inHg) maximum vacuum loss for 15 seconds at vacuum of -66.7 kPa (-500 mmHg, -19.69 inHg)
When suitable tool (A) is connected to engine side (C)	No vacuum should exist.

Brake Booster

INFOID:0000000012551776

Unit: mm (in)

Item	Standard
Input rod length	127 (5.00)

SERVICE DATA AND SPECIFICATIONS (SDS)

< SERVICE DATA AND SPECIFICATIONS (SDS)

Front Disc Brake

INFOID:000000012551777

Unit: mm (in)

Item		Limit
Brake pad	Wear thickness	2.0 (0.079)
Disc brake rotor	Wear thickness	26.0 (1.024)
	Thickness variation (measured at 8 positions)*	0.008 (0.0003)
	Runout (with disc brake rotor attached to the vehicle)	0.040 (0.0016) or less

*To check if rotor imbalance, rotor runout or rotor deformation exists.

Rear Disc Brake

INFOID:000000012551778

Unit: mm (in)

Item		Limit
Brake pad	Wear thickness	2.0 (0.079)
Disc brake rotor	Wear thickness	14.0 (0.551)
	Thickness variation (measured at 8 positions)*	0.020 (0.0008)
	Runout (with disc brake rotor attached to the vehicle)	0.050 (0.0020) or less

*To check if rotor imbalance, rotor runout or rotor deformation exists.

A
B
C
D
E
BR
G
H
I
J
K
L
M
N
O
P