

SERVICE BULLETIN

Classification: EM93-002	Section: Engine Mechanical	Models: All w/VE30DE Engine
Reference: TECHNICAL BULLETIN NTB93-126	Date: September 2, 1993	

VE30DE CAM TIMING

APPLIED MODELS: All equipped with VE30DE Engine

SERVICE INFORMATION:

When servicing VE30DE engine cylinder heads, cams, or upper cam chain or tensioners, use the following procedure to **set cam timing**. This will supplement information found in the EM section of the Service Manual.

SERVICE PROCEDURE:

Removal:

Prior to any top end service:

1. Set #1 cylinder on "Top Dead Center" (TDC), Compression Stroke (Figures 1 and 2).

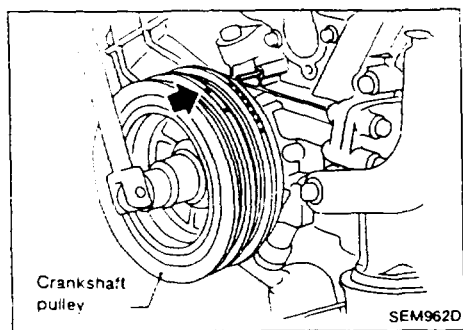

Figure 1

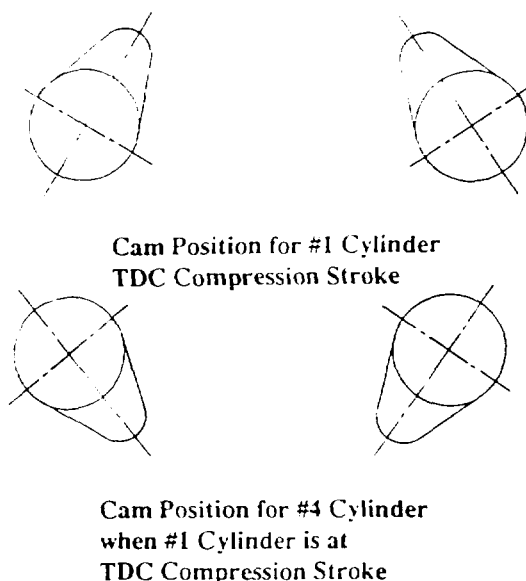

Figure 2

2. Refer to EM Section in Service Manual for removal procedure for valve covers and upper timing chain covers.
3. Use a suitable solvent to clean the cam flange behind each cam sprocket and the front cam chain links, adjacent to each cam sprocket timing mark.
4. Verify the engine is on TDC #1 cylinder, Compression Stroke. Using a **fine point indelible marker**, carefully scribe a match mark on each cam flange, in line with the arrow on the front cam journal cap. It is important that this mark will not be removed even when wet by oil (Figure 3).

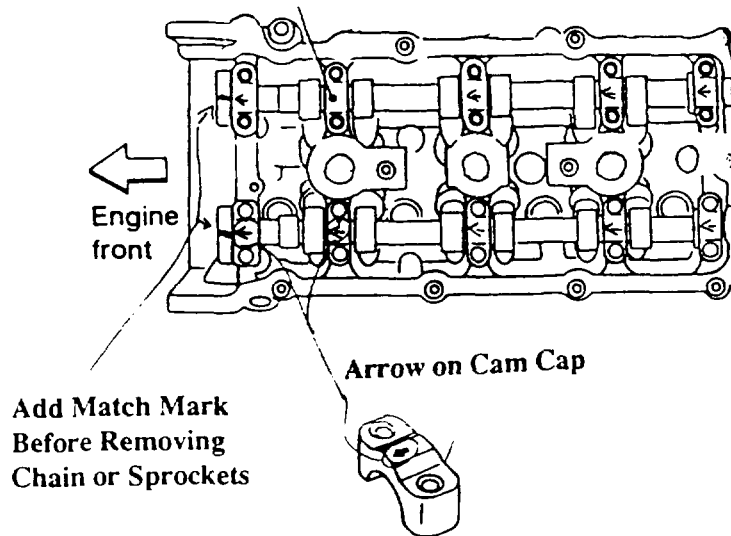

Figure 3

5. Use the indelible marker to scribe a "match mark" on the chain links adjacent to the cam sprocket timing marks (Figure 4).

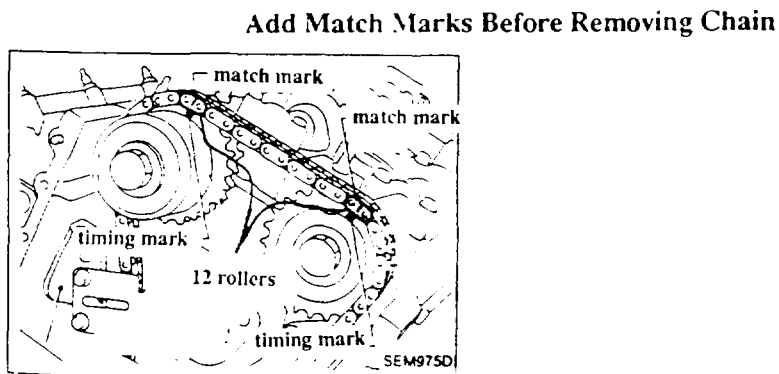

Figure 4

6. To ensure that all cam caps are reinstalled correctly, mark the cam caps for both intake and exhaust cams. For example, mark "RE-1" through "RE-5" on the RH exhaust cam caps; "LI-1" through "LI-5" for the LH Intake cam caps (Figure 5).

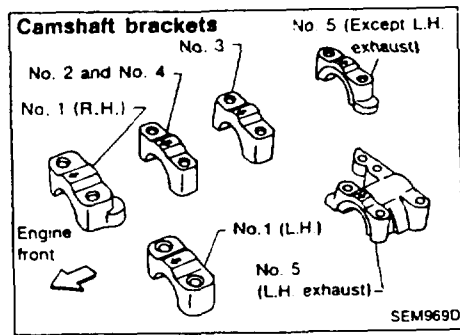

Figure 5

7. Service the cylinder heads, cams, upper cam chain or tensioners, as necessary.
8. When servicing cam shafts or cylinder heads, be sure to keep lifter and rocker arms together with their respective cam lobe.

Installation:

NOTE: All references to locations on the engine are taken from the flywheel looking forward with respect to the engine. The right hand cylinder head is closest to the windshield and the left hand cylinder head is closest to the radiator. (Figure 6)

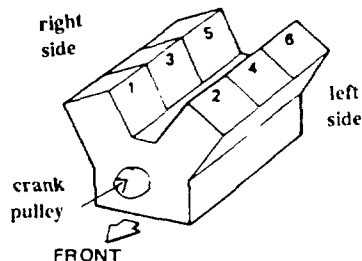

Figure 6
3/7

1. Prior to installing camshafts or cylinder heads, turn crankshaft by hand until No. 1 piston is set at approximately 120 degrees Before Top Dead Center (BTDC) on its compression stroke. This step is important to prevent interference between the pistons and valves. Be sure to hold the upper timing chains to allow them to rotate freely when turning the engine. (Figure 7)

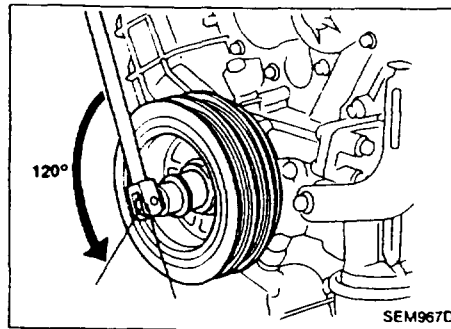
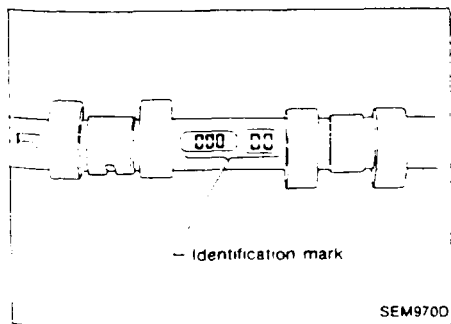

Figure 7

2. Install cylinder head and camshafts as outlined in the 1993 Maxima Service Manual (page EM60). Pay attention to the **cam identification**, RE for right exhaust and LE for left exhaust; RI for right intake and LI for left intake. (Figure 8)



	Identification mark
R H exhaust camshaft	96E RE
L H exhaust camshaft	96E LE

Figure 8

3. To prevent valve or cam damage, be sure to install the cam shafts with the RH cam sprocket dowels in the 10 o'clock position and the LH cam sprocket dowels in the 12 o'clock position. (Figure 9)

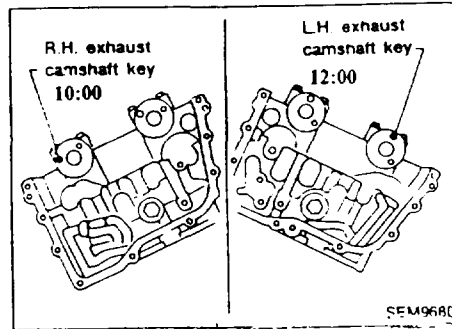

Figure 9

Cam Timing:

1. With the engine still set at 120 degrees BTDC, install the cam sprockets on the RH cylinder head, aligning the chain marks with the sprocket timing marks. Be sure all slack is removed from the drive side of the chain [the drive side does not have the tensioner]. (Figure 10)

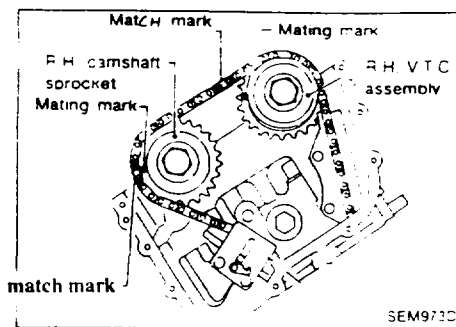

Figure 10
5/7

2. Hold the LH timing chain to keep it from binding and rotate the engine by hand to Top Dead Center, # 1 cylinder, compression stroke. (Figure 11)

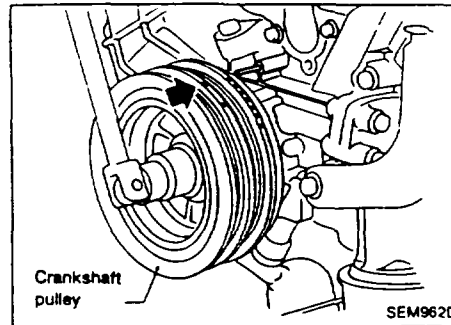

Figure 11

3. Verify that the match marks you scribed on the RH *cam front flange* align with the arrows on the front cam caps. Adjust cam sprocket to chain alignment, as necessary, to ensure that the match marks align (See Figure 3).
4. Verify that the RH *cam chain marks* align with the sprocket timing marks and that the match marks on the cam front flange still align with the arrows on the front cam caps. (see Figure 4)
5. Install the LH cam chain and sprockets. Be sure all the slack is removed from the drive side of the chain.
6. Verify that the LH chain match marks align with the sprocket timing marks and that the match marks on the cam flange align with the cam cap arrows. (see Figure 4)
7. If the tensioners were removed, install them at this time (Figure 12)

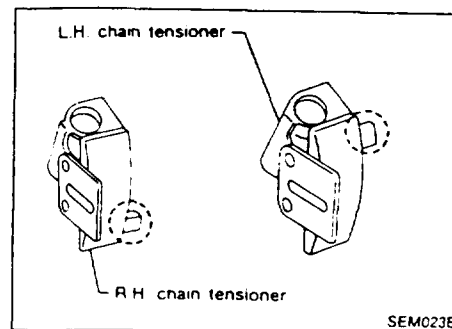

Figure 12

8. With the spark plugs removed, rotate the engine, by hand, four revolutions clockwise and set it to Top Dead Center (TDC), compression, #1 cylinder. Be sure the engine turns freely. If it does not turn freely, stop immediately and recheck assembly procedures.
9. Verify that the intake and exhaust cam match marks align with the cam cap arrows on both cylinder heads.
10. The cams are now "in time." Continue with engine assembly.

NISSAN MOTOR CORPORATION U.S.A.
Technical Publications Department