

A
CO
C
D
E
F
G
H
I
J
K
L
M
N
O
P

SECTION CO

ENGINE COOLING SYSTEM

CONTENTS

VQ40DE	
PRECAUTION	3
PRECAUTIONS	3
Precaution for Supplemental Restraint System (SRS) "AIR BAG" and "SEAT BELT PRE-TENSIONER"	3
Precaution Necessary for Steering Wheel Rotation After Battery Disconnect	3
Precaution for Liquid Gasket	4
PREPARATION	5
PREPARATION	5
Special Service Tool	5
Commercial Service Tool	5
FUNCTION DIAGNOSIS	7
COOLING SYSTEM	7
Cooling Circuit	7
Schematic	8
OVERHEATING CAUSE ANALYSIS	9
Troubleshooting Chart	9
ON-VEHICLE MAINTENANCE	11
ENGINE COOLANT	11
System Inspection	11
Changing Engine Coolant	12
ON-VEHICLE REPAIR	16
RADIATOR	16
Exploded View	16
Removal and Installation	16
Checking Radiator	18
ENGINE COOLING FAN	19
Exploded View	19
Removal and Installation (Crankshaft driven type)... ..	19
Removal and Installation (Motor driven type)	20
WATER PUMP	22
Exploded View	22
Removal and Installation	22
WATER INLET AND THERMOSTAT ASSEMBLY	27
Exploded View	27
Removal and Installation	27
WATER OUTLET AND WATER PIPING	29
Exploded View	29
Removal and Installation	29
SERVICE DATA AND SPECIFICATIONS (SDS)	30
SERVICE DATA AND SPECIFICATIONS (SDS)	30
Standard and Limit	30
VK56DE	
PRECAUTION	31
PRECAUTIONS	31
Precaution for Supplemental Restraint System (SRS) "AIR BAG" and "SEAT BELT PRE-TENSIONER"	31
Precaution Necessary for Steering Wheel Rotation After Battery Disconnect	31
Precaution for Liquid Gasket	32
PREPARATION	33
PREPARATION	33
Special Service Tool	33
Commercial Service Tool	33
FUNCTION DIAGNOSIS	35
COOLING SYSTEM	35

Cooling Circuit	35	Exploded View	48
Schematic	36	Removal and Installation (Crankshaft Driven Type)	48
OVERHEATING CAUSE ANALYSIS	37	Removal and Installation (Motor Driven Type)	49
Troubleshooting Chart	37	WATER PUMP	51
ON-VEHICLE MAINTENANCE	39	Exploded View	51
ENGINE COOLANT	39	Removal and Installation	51
System Inspection	39	THERMOSTAT AND WATER PIPING	53
Changing Engine Coolant	40	Exploded View	53
ON-VEHICLE REPAIR	44	Removal and Installation	53
RADIATOR	44	SERVICE DATA AND SPECIFICATIONS (SDS)	55
Exploded View	44	SERVICE DATA AND SPECIFICATIONS (SDS)	55
Removal and Installation	44	Standard and Limit	55
Checking Radiator	46		
ENGINE COOLING FAN	48		

PRECAUTION

PRECAUTIONS

Precaution for Supplemental Restraint System (SRS) "AIR BAG" and "SEAT BELT PRE-TENSIONER"

INFOID:000000005531978

The Supplemental Restraint System such as "AIR BAG" and "SEAT BELT PRE-TENSIONER", used along with a front seat belt, helps to reduce the risk or severity of injury to the driver and front passenger for certain types of collision. This system includes seat belt switch inputs and dual stage front air bag modules. The SRS system uses the seat belt switches to determine the front air bag deployment, and may only deploy one front air bag, depending on the severity of a collision and whether the front occupants are belted or unbelted. Information necessary to service the system safely is included in the SR and SB section of this Service Manual.

WARNING:

- To avoid rendering the SRS inoperative, which could increase the risk of personal injury or death in the event of a collision which would result in air bag inflation, all maintenance must be performed by an authorized NISSAN/INFINITI dealer.
- Improper maintenance, including incorrect removal and installation of the SRS, can lead to personal injury caused by unintentional activation of the system. For removal of Spiral Cable and Air Bag Module, see the SR section.
- Do not use electrical test equipment on any circuit related to the SRS unless instructed to in this Service Manual. SRS wiring harnesses can be identified by yellow and/or orange harnesses or harness connectors.

PRECAUTIONS WHEN USING POWER TOOLS (AIR OR ELECTRIC) AND HAMMERS

WARNING:

- When working near the Airbag Diagnosis Sensor Unit or other Airbag System sensors with the Ignition ON or engine running, DO NOT use air or electric power tools or strike near the sensor(s) with a hammer. Heavy vibration could activate the sensor(s) and deploy the air bag(s), possibly causing serious injury.
- When using air or electric power tools or hammers, always switch the Ignition OFF, disconnect the battery, and wait at least 3 minutes before performing any service.

Precaution Necessary for Steering Wheel Rotation After Battery Disconnect

INFOID:000000005260549

NOTE:

- This Procedure is applied only to models with Intelligent Key system and NATS (NISSAN ANTI-THEFT SYSTEM).
- Remove and install all control units after disconnecting both battery cables with the ignition knob in the "LOCK" position.
- Always use CONSULT-III to perform self-diagnosis as a part of each function inspection after finishing work. If DTC is detected, perform trouble diagnosis according to self-diagnostic results.

For models equipped with the Intelligent Key system and NATS, an electrically controlled steering lock mechanism is adopted on the key cylinder.

For this reason, if the battery is disconnected or if the battery is discharged, the steering wheel will lock and steering wheel rotation will become impossible.

If steering wheel rotation is required when battery power is interrupted, follow the procedure below before starting the repair operation.

OPERATION PROCEDURE

1. Connect both battery cables.

NOTE:

Supply power using jumper cables if battery is discharged.

2. Use the Intelligent Key or mechanical key to turn the ignition switch to the "ACC" position. At this time, the steering lock will be released.
3. Disconnect both battery cables. The steering lock will remain released and the steering wheel can be rotated.
4. Perform the necessary repair operation.

A
CO
C
D
E
F
G
H
I
J
K
L
M
N
O
P

PRECAUTIONS

[VQ40DE]

< PRECAUTION >

- When the repair work is completed, return the ignition switch to the "LOCK" position before connecting the battery cables. (At this time, the steering lock mechanism will engage.)
- Perform a self-diagnosis check of all control units using CONSULT-III.

Precaution for Liquid Gasket

INFOID:000000005260550

REMOVAL OF LIQUID GASKET SEALING

- After removing nuts and bolts, separate the mating surface and remove old liquid gasket sealing using Tool.

Tool number : KV10111100 (J-37228)

CAUTION:

Be careful not to damage the mating surfaces.

- Tap seal cutter to insert it (1), and then slide it by tapping on the side (2) as shown.
- In areas where Tool is difficult to use, use plastic hammer to lightly tap the part, to remove it.

CAUTION:

If for some unavoidable reason tool such as screwdriver is used, be careful not to damage the mating surfaces.

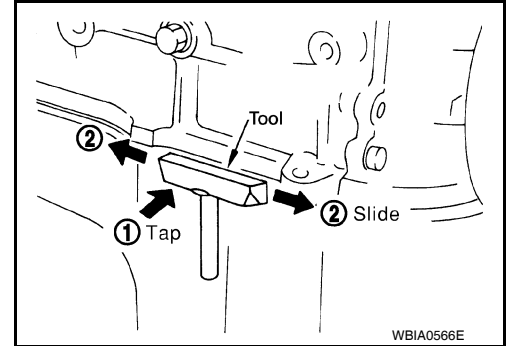

LIQUID GASKET APPLICATION PROCEDURE

- Remove the old liquid gasket adhering to the gasket application surface and the mating surface using suitable tool.
 - Remove liquid gasket completely from the groove of the gasket application surface, bolts, and bolt holes.
- Thoroughly clean the mating surfaces and remove adhering moisture, grease and foreign materials.

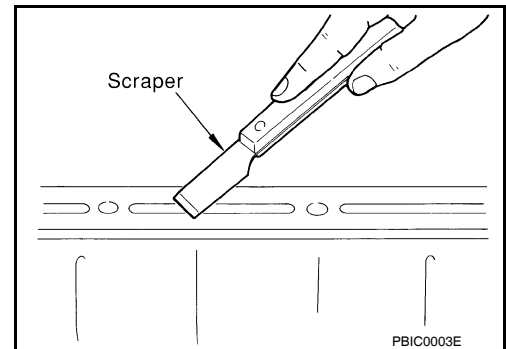

- Attach liquid gasket tube to the Tool.

Tool number : WS39930000 (—)

Use Genuine RTV Silicone Sealant or equivalent. Refer to [GI-14, "Recommended Chemical Products and Sealants"](#).

- Apply the liquid gasket without breaks to the specified location with the specified dimensions.

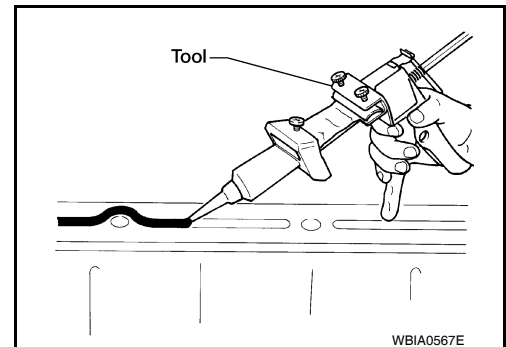

- If there is a groove for the liquid gasket application, apply the liquid gasket to the groove.
- As for bolt holes, normally apply the liquid gasket inside the holes. Occasionally, it should be applied outside the holes. Make sure to read the text of this manual.
- Within five minutes of liquid gasket application, install the mating component.
- If the liquid gasket protrudes, wipe it off immediately.
- Do not retighten nuts or bolts after the installation.
- Wait 30 minutes or more after installation, before refilling the engine with engine oil and engine coolant.

CAUTION:

If there are specific instructions in this manual, observe them.

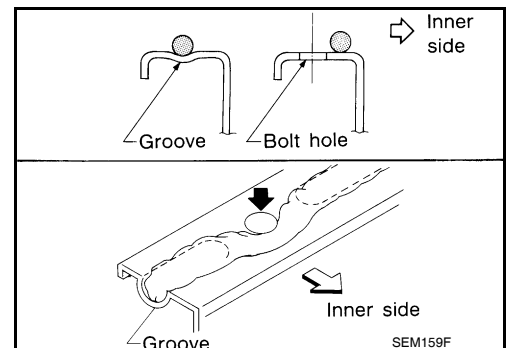

PREPARATION

< PREPARATION >

[VQ40DE]

PREPARATION

PREPARATION

Special Service Tool

INFOID:000000005260551

A

CO

The actual shapes of Kent-Moore tools may differ from those of special service tools illustrated here.

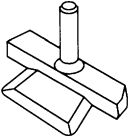
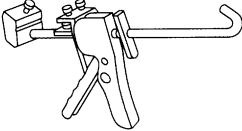
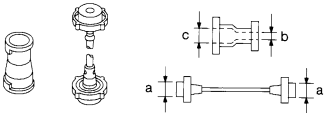
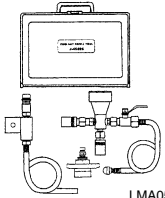
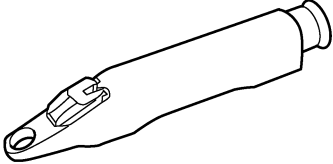
Tool number (Kent-Moore No.) Tool name	Description
KV10111100 (J-37228) Seal cutter  NT046	Removing chain tensioner cover and water pump cover D E
WS39930000 (—) Tube presser  S-NT052	Pressing the tube of liquid gasket F G H
EG17650301 (J-33984-A) Radiator cap tester adapter  S-NT564	Adapting radiator cap tester to radiator cap and radiator filler neck a: 28 (1.10) dia. b: 31.4 (1.236) dia. c: 41.3 (1.626) dia. Unit: mm (in) I J
KV991J0070 (J-45695) Coolant refill tool  LMA053	Filling cooling system K L M
KV991J0010 (J-23688) Engine coolant refractometer  WBIA0539E	Checking concentration of ethylene glycol in engine coolant N O

Commercial Service Tool

INFOID:000000005260552

P

PREPARATION

< PREPARATION >

[VQ40DE]

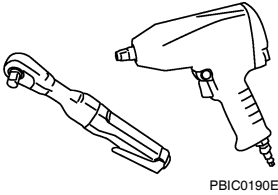
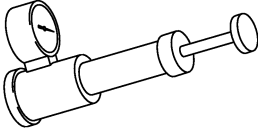
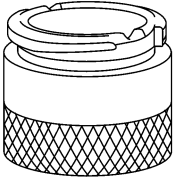
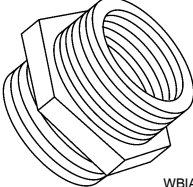
Tool name	Description
<p data-bbox="159 197 272 224">Power tool</p>  <p data-bbox="829 415 899 434">PBIC0190E</p>	<p data-bbox="1013 197 1263 224">Loosening bolts and nuts</p>
<p data-bbox="159 449 354 476">Radiator cap tester</p>  <p data-bbox="829 663 899 682">PBIC1982E</p>	<p data-bbox="1013 449 1360 476">Checking radiator and radiator cap</p>
<p data-bbox="159 701 467 728">Coolant system tester adapter</p>  <p data-bbox="829 919 899 938">WBIA0408E</p>	<p data-bbox="1013 701 1458 758">Adapting radiator cap tester to reservoir filler neck</p>
<p data-bbox="159 953 467 980">Coolant system tester adapter</p>  <p data-bbox="829 1167 899 1186">WBIA0409E</p>	<p data-bbox="1013 953 1458 980">Adapting radiator cap tester to reservoir cap</p>

FUNCTION DIAGNOSIS

COOLING SYSTEM

Cooling Circuit

INFOID:000000005260553

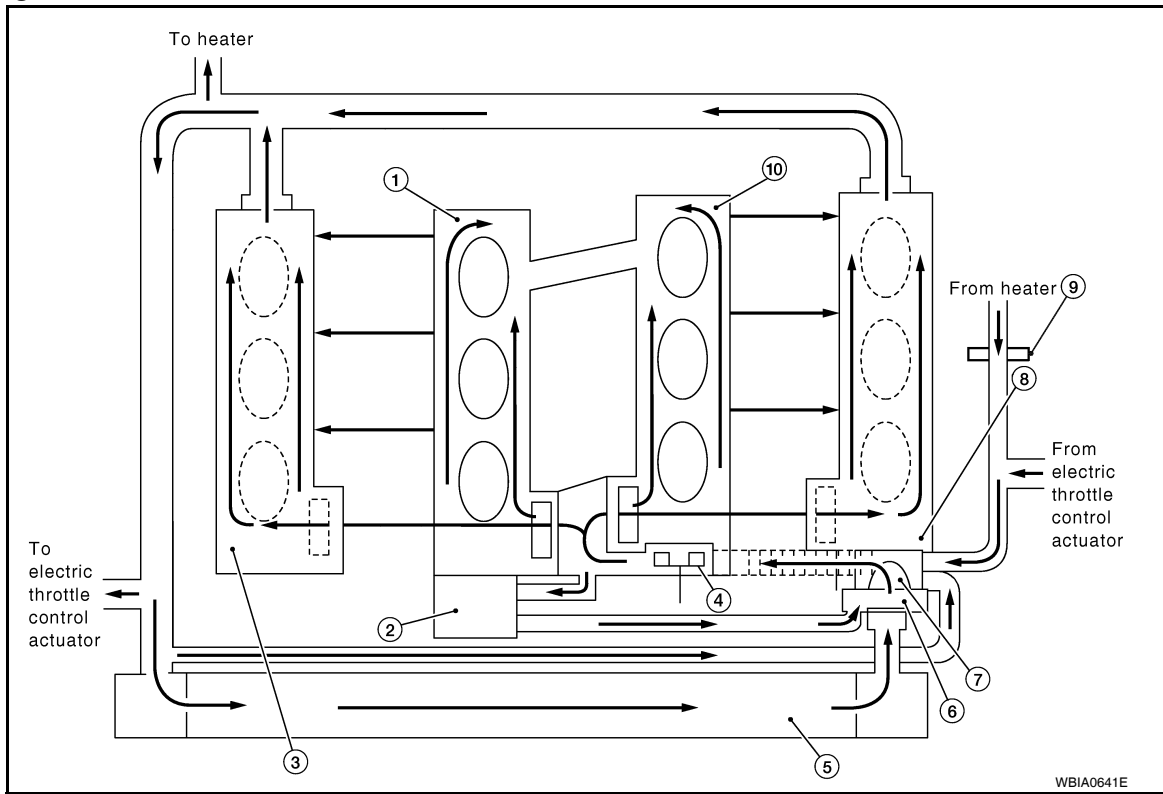

- | | | |
|-------------------------|-----------------------|-----------------------|
| 1. Cylinder block (RH) | 2. Oil cooler | 3. Cylinder head (RH) |
| 4. Water pump | 5. Radiator | 6. Water inlet |
| 7. Thermostat | 8. Cylinder head (LH) | 9. Heater pump |
| 10. Cylinder block (LH) | | |

A
CO
C
D
E
F
G
H
I
J
K
L
M
N
O
P

COOLING SYSTEM

< FUNCTION DIAGNOSIS >

[VQ40DE]

Schematic

INFOID:000000005260554

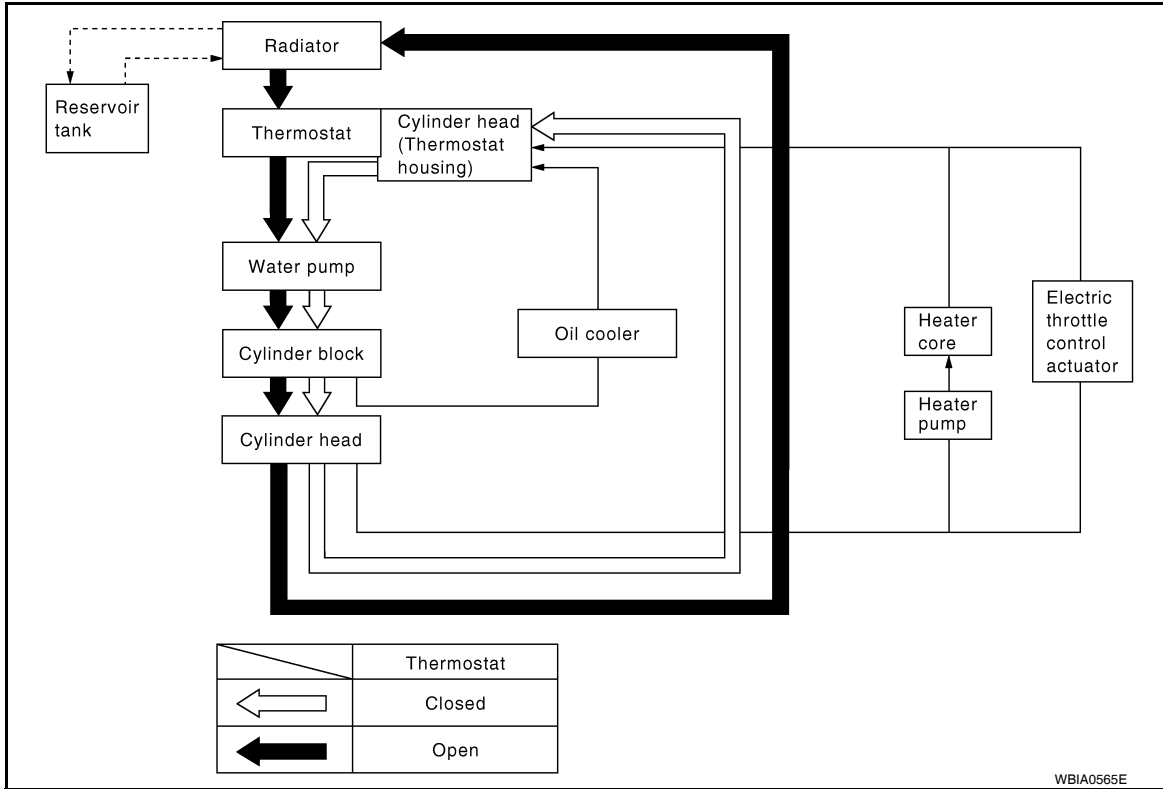

OVERHEATING CAUSE ANALYSIS

< FUNCTION DIAGNOSIS >

[VQ40DE]

OVERHEATING CAUSE ANALYSIS

Troubleshooting Chart

INFOID:000000005260555

	Symptom		Check items	
Cooling system parts malfunction	Poor heat transfer	Water pump malfunction	Worn or loose drive belt	—
		Thermostat stuck closed	—	
		Damaged fins	Dust contamination or paper clogging	
			Physical damage	
		Clogged radiator cooling tube	Excess foreign material (rust, dirt, sand, etc.)	
	Reduced air flow	Cooling fan does not operate	Fan assembly	—
		High resistance to fan rotation		
		Damaged fan blades		
	Damaged radiator shroud	—	—	—
	Improper engine coolant mixture ratio	—	—	—
	Poor engine coolant quality	—	Engine coolant viscosity	—
	Insufficient engine coolant	Engine coolant leaks	Cooling hose	Loose clamp
				Cracked hose
			Heater pump	Physical damage
			Water pump	Poor sealing
		Radiator cap	Loose	
			Poor sealing	
		Radiator	O-ring for damage, deterioration or improper fitting	
Cracked radiator tank				
Cracked radiator core				
Reservoir tank	Cracked reservoir tank			
Overflowing reservoir tank	Exhaust gas leaks into cooling system	Cylinder head deterioration		
		Cylinder head gasket deterioration		

A
CO
C
D
E
F
G
H
I
J
K
L
M
N
O
P

OVERHEATING CAUSE ANALYSIS

< FUNCTION DIAGNOSIS >

[VQ40DE]

		Symptom		Check items	
Except cooling system parts malfunction	—	Overload on engine	Abusive driving	High engine rpm under no load	—
				Driving in low gear for extended time	
				Driving at extremely high speed	
			Powertrain system malfunction		
			Installed improper size wheels and tires		
			Dragging brakes		
	Blocked or restricted air flow	Blocked or restricted air flow	Blocked bumper	—	—
			Blocked radiator grille	Installed car brassiere	
				Mud contamination or paper clogging	
			Blocked radiator	—	
Blocked condenser			Blocked air flow		
Installed large fog lamp					

ON-VEHICLE MAINTENANCE

ENGINE COOLANT

System Inspection

INFOID:000000005260556

WARNING:

- Never remove the radiator/reservoir cap when the engine is hot. Serious burns could occur from high pressure fluid escaping from the radiator or reservoir.
- Wrap a thick cloth around the cap. Slowly push down and turn it a quarter turn to allow built-up pressure to escape. Carefully remove the cap by pushing down and turning it all the way.

CHECKING COOLING SYSTEM HOSES

Check hoses for the following:

- Improper attachment
- Leaks
- Cracks
- Damage
- Loose connections
- Chafing
- Deterioration

CHECKING RESERVOIR LEVEL

- Check if the engine coolant reservoir tank level is within MIN to MAX when the engine is cool.
- Adjust engine coolant level as necessary.

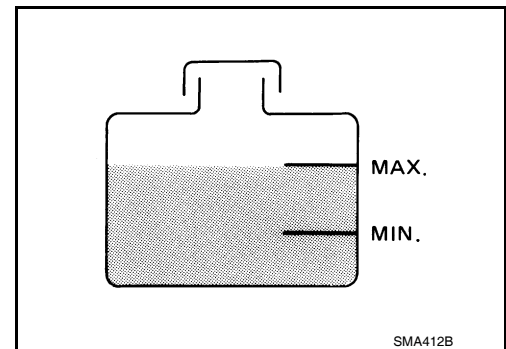

CHECKING COOLING SYSTEM FOR LEAKS

WARNING:

Never remove the radiator/reservoir cap when the engine is hot. Serious burns could occur from high pressure coolant escaping from the radiator or reservoir.

- To check for leakage, apply pressure to the cooling system at the reservoir filler neck using suitable tool and Tool.

Tool number : EG17650301 (J-33984-A)

Testing pressure : 137 kPa (1.4 kg/cm², 20 psi)

CAUTION:

Higher pressure than specified may cause radiator damage.

NOTE:

In case that engine coolant decreases, replenish cooling system with engine coolant.

- If any concerns are found, repair or replace damaged parts.

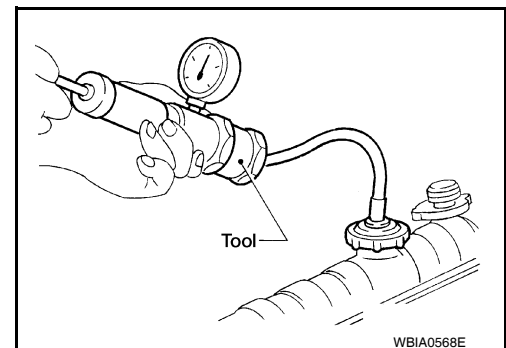

CHECKING RESERVOIR CAP

ENGINE COOLANT

< ON-VEHICLE MAINTENANCE >

[VQ40DE]

- Check reservoir cap relief pressure using suitable tool and Tool.

Tool number : EG17650301 (J-33984-A)

Standard: 98 – 118 kPa (1.0 – 1.2 kg/cm², 14 – 17 psi)

NOTE:

- Apply engine coolant to the cap seal.
- Replace the reservoir cap if there is any damage in the negative-pressure valve, or if the open-valve pressure is outside of the limit.

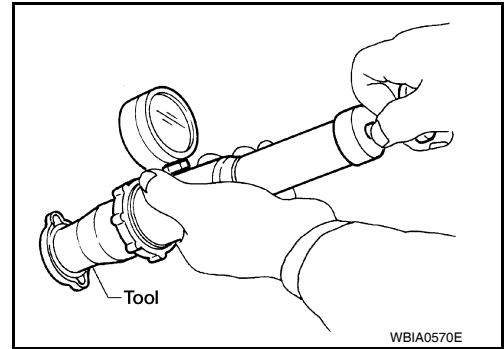

CHECKING RADIATOR CAP

Inspect the radiator cap.

NOTE:

Thoroughly wipe out the radiator filler neck to remove any waxy residue or foreign material.

- Replace the cap if the metal plunger cannot be seen around the edge of the black rubber gasket.
- Replace the cap if deposits of waxy residue or other foreign material are on the black rubber gasket or the metal retainer.

CHECKING RADIATOR

Check radiator for mud or clogging. If necessary, clean radiator as follows.

CAUTION:

- **Be careful not to bend or damage the radiator fins.**
 - **When radiator is cleaned without removal, remove all surrounding parts such as cooling fan shroud and horns. Then tape the harness and electrical connectors to prevent water from entering.**
1. Apply water by hose to the back side of the radiator core, with the hose pointed vertically downward.
 2. Apply water again to all radiator core surfaces once per minute.
 3. Stop washing if any stains no longer flow out from the radiator.
 4. Blow air into the back side of radiator core, with the air hose pointed vertically downward.
 - Use compressed air lower than 490 kPa (5 kg/cm², 71 psi) and keep distance more than 30 cm (11.8 in).
 5. Blow air again into all the radiator core surfaces once per minute until no water sprays out.
 6. Check for leaks.

Changing Engine Coolant

INFOID:000000005260557

WARNING:

- **To avoid being scalded, never change the coolant when the engine is hot.**
- **Wrap a thick cloth around the cap to carefully remove the cap. First, turn the cap a quarter of a turn to release any built-up pressure, then push down and turn the cap all the way to remove it.**

DRAINING ENGINE COOLANT

1. Turn ignition switch ON and set temperature control lever all the way to HOT position or the highest temperature position. Wait 10 seconds and turn ignition switch OFF.
2. Remove the engine front undercover using power tool.
3. Open the radiator drain plug at the bottom of the radiator, and remove the reservoir cap. This is the only step required when partially draining the cooling system (radiator only).

CAUTION:

Do not allow the coolant to contact the drive belts.

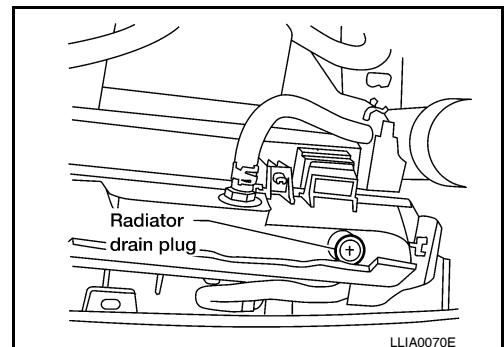

ENGINE COOLANT

[VQ40DE]

< ON-VEHICLE MAINTENANCE >

- When draining all of the coolant in the system for engine removal or repair, it is necessary to drain the cylinder block. Remove the cylinder block drain plugs (A), (B), (C), (D) and block heater if equipped, to drain the cylinder block as shown.

NOTE:

For Canada, the (D) cylinder block drain plug as shown, is not a cylinder block drain plug but a block heater.

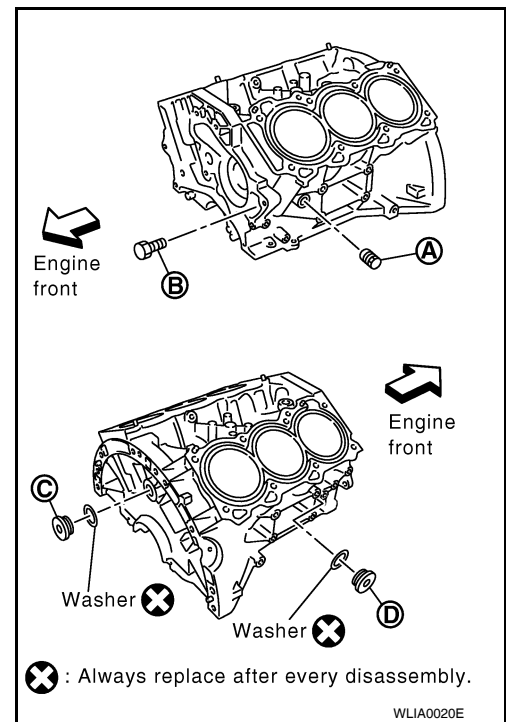

- Remove the reservoir tank to drain the engine coolant, then clean the reservoir tank before installing it.
- Check the drained coolant for contaminants such as rust, corrosion or discoloration. If the coolant is contaminated, flush the engine cooling system. Refer to [CO-12, "Changing Engine Coolant"](#).

REFILLING ENGINE COOLANT

- Close the radiator drain plug. Install the reservoir tank, cylinder block drain plugs (A), (B), (C), (D) and block heater if equipped, if removed for a total system drain or for engine removal or repair.
 - The radiator must be completely empty of coolant and water.
 - Apply sealant to the threads of the cylinder block drain plugs (A), (B), (C), (D). Use Genuine High Performance Thread Sealant or equivalent. Refer to [GI-14, "Recommended Chemical Products and Sealants"](#).

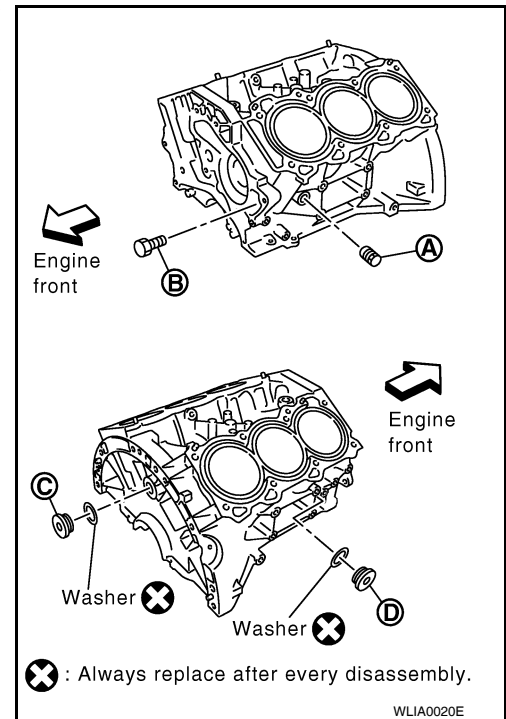

Block Plug and Block Heater Installation

Part	Washer	Tightening Torque
A	No	Refer to EM-102, "Disassembly and Assembly" .
B	Reuse	Refer to EM-102, "Disassembly and Assembly" .
	New	Refer to EM-102, "Disassembly and Assembly" .

ENGINE COOLANT

< ON-VEHICLE MAINTENANCE >

[VQ40DE]

Part	Washer	Tightening Torque
C	Yes	Refer to EM-102, "Disassembly and Assembly" .
D	Plug	Refer to EM-102, "Disassembly and Assembly" .
	Block heater	Refer to EM-102, "Disassembly and Assembly" .

- Set the vehicle heater controls to the full HOT and heater ON position. Turn the vehicle ignition ON with the engine OFF as necessary to activate the heater mode.
- Remove the vented reservoir cap and replace it with a non-vented reservoir cap before filling the cooling system.
- Install the Tool by installing the radiator cap adapter onto the radiator neck opening. Then attach the gauge body assembly with the refill tube and the venturi assembly to the radiator cap adapter.

Tool number : KV991J0070 (J-45695)

- Insert the refill hose into the coolant mixture container that is placed at floor level. Make sure the ball valve is in the closed position.
 - Use recommended coolant or equivalent. Refer to [MA-16, "For North America"](#).

Cooling system capacity (with reservoir) : Refer to [MA-16, "For North America"](#).

- Install an air hose to the venturi assembly, the air pressure must be within specification.

Compressed air supply pressure : 549 - 824 kPa (5.6 - 8.4 kg/cm², 80 - 119 psi)

CAUTION:

The compressed air supply must be equipped with an air dryer.

- The vacuum gauge will begin to rise and there will be an audible hissing noise. During this process open the ball valve on the refill hose slightly. Coolant will be visible rising in the refill hose. Once the refill hose is full of coolant, close the ball valve. This will purge any air trapped in the refill hose.

- Continue to draw the vacuum until the gauge reaches 28 inches of vacuum. The gauge may not reach 28 inches in high altitude locations, use the vacuum specifications based on the altitude above sea level.

Altitude above sea level	Vacuum gauge reading
0 - 100 m (328 ft)	: 28 inches of vacuum
300 m (984 ft)	: 27 inches of vacuum
500 m (1,641 ft)	: 26 inches of vacuum
1,000 m (3,281 ft)	: 24 - 25 inches of vacuum

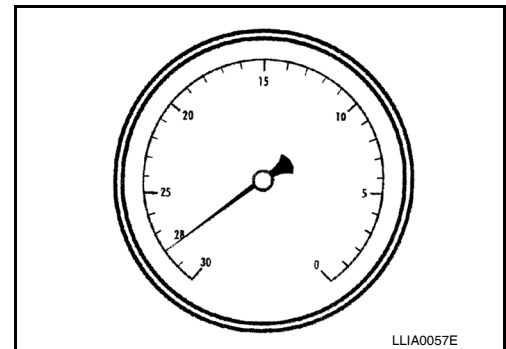
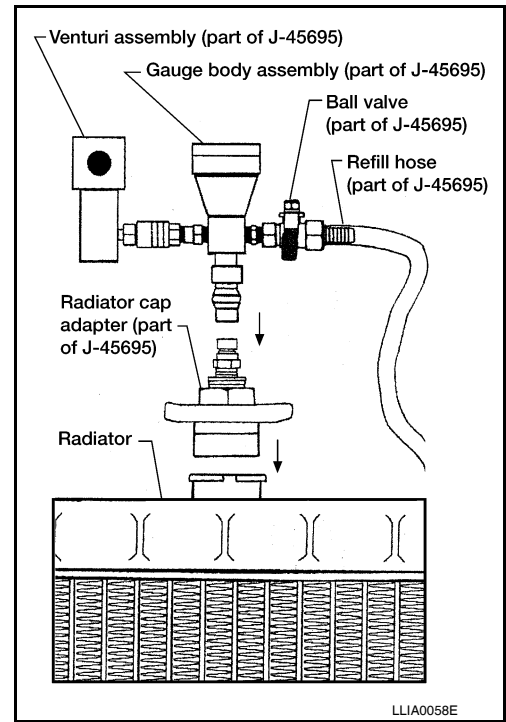

- When the vacuum gauge has reached the specified amount, disconnect the air hose and wait 20 seconds to see if the system loses any vacuum. If the vacuum level drops, perform any necessary repairs to the system and repeat steps 6 - 8 to bring the vacuum to the specified amount. Recheck for any leaks.
- Place the coolant container (with the refill hose inserted) at the same level as the top of the radiator. Then open the ball valve on the refill hose so the coolant will be drawn up to fill the cooling system. The cooling system is full when the vacuum gauge reads zero.

CAUTION:

Do not allow the coolant container to get too low when filling, to avoid air from being drawn into the cooling system.

ENGINE COOLANT

< ON-VEHICLE MAINTENANCE >

[VQ40DE]

11. Remove the Tool from the radiator neck opening and install the radiator cap.
12. Remove the non-vented reservoir cap.
13. Fill the cooling system reservoir tank to the specified level. Run the engine to warm up the cooling system and top up the system as necessary before installing the vented reservoir cap.

A

CO

FLUSHING COOLING SYSTEM

1. Drain the water from the engine cooling system. Refer to [CO-12, "Changing Engine Coolant"](#).
2. Fill the radiator and the reservoir tank (to the "MAX" line), with water. Reinstall the radiator cap and leave the vented reservoir cap off.
3. Run the engine until it reaches normal operating temperature.
4. Press the engine accelerator two or three times under no-load.
5. Stop the engine and wait until it cools down.
6. Drain the water from the engine cooling system. Refer to [CO-12, "Changing Engine Coolant"](#).
7. Repeat steps 2 through 6 until clear water begins to drain from the radiator.

C

D

E

F

G

H

I

J

K

L

M

N

O

P

RADIATOR

< ON-VEHICLE REPAIR >

[VQ40DE]

ON-VEHICLE REPAIR

RADIATOR

Exploded View

INFOID:000000005260558

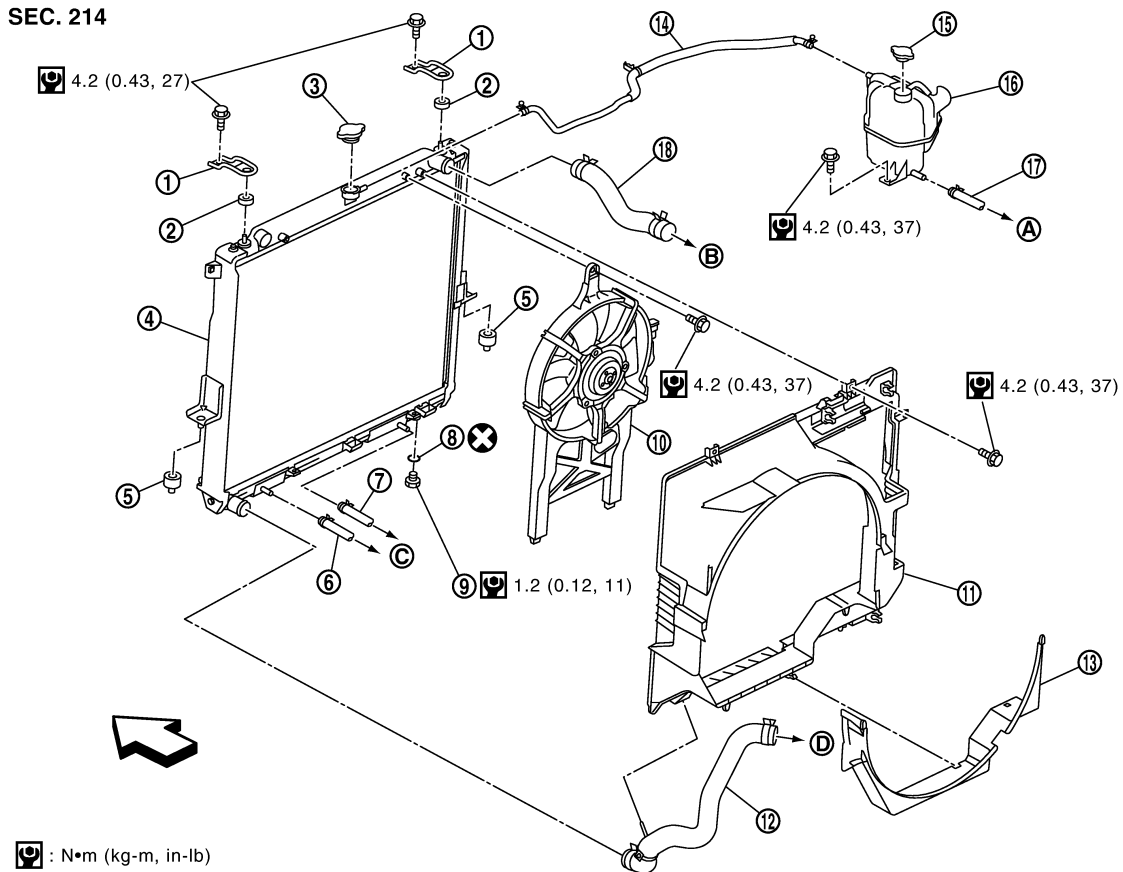

PBIC3861E

- | | | |
|---|-----------------------------|---------------------------|
| 1. Upper mount bracket | 2. Mounting rubber (upper) | 3. Radiator cap |
| 4. Radiator | 5. Mounting rubber (lower) | 6. A/T fluid cooler hose |
| 7. A/T fluid cooler hose | 8. O-ring | 9. Drain plug |
| 10. Cooling fan assembly | 11. Radiator shroud (upper) | 12. Radiator hose (lower) |
| 13. Radiator shroud (lower) | 14. Reservoir tank hose | 15. Reservoir tank cap |
| 16. Reservoir tank | 17. Water hose | 18. Radiator hose (upper) |
| A. To heater return tube | B. To water pipe | C. To A/T cooler tube |
| D. To water inlet and thermostat assembly | ↙ Vehicle front | |

Removal and Installation

INFOID:000000005260559

WARNING:

Do not remove radiator cap when engine is hot. Serious burns could occur from high-pressure engine coolant escaping from radiator. Wrap a thick cloth around the cap. Slowly turn it a quarter of a turn to release built-up pressure. Carefully remove radiator cap by turning it all the way.

REMOVAL

1. Remove engine under cover. Refer to [EXT-14. "Removal and Installation"](#)
2. Drain engine coolant from radiator. Refer to [CO-11](#).

CAUTION:

- Perform this step when engine is cold.
- Do not spill engine coolant on drive belts.

RADIATOR

[VQ40DE]

< ON-VEHICLE REPAIR >

3. Remove engine room cover. Refer to [EM-25, "Removal and Installation"](#).
4. Remove air duct and resonator assembly and air cleaner case (upper). Refer to [EM-26, "Removal and Installation"](#).
5. Remove reservoir tank hose.
6. Remove radiator hoses (upper and lower).
CAUTION:
Be careful not to allow engine coolant to contact drive belts.
7. Disconnect A/T fluid cooler hoses.
 - Install blind plug to avoid leakage of A/T fluid.
8. Remove radiator shroud (lower).
9. Remove radiator shroud (upper).
10. Remove engine cooling fan (Motor driven type). Refer to [CO-20, "Removal and Installation \(Motor driven type\)"](#).
11. Remove front grille. Refer to [EXT-18, "Removal and Installation"](#).
12. Remove the upper mount bracket bolts.

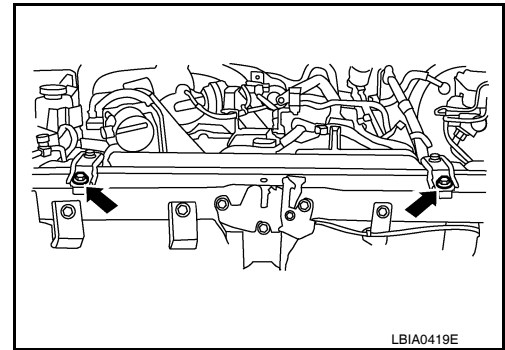

13. Remove the two A/C condenser bolts.

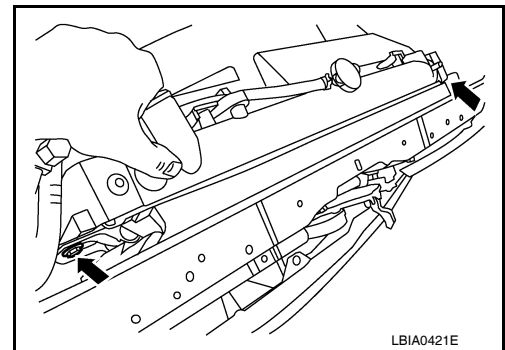

14. Remove radiator as follows:

CAUTION:

Do not damage or scratch A/C condenser and radiator core when removing.

- a. With lifting and pulling radiator in a rear direction, disassemble mounting rubber (lower) from radiator core support center.

CAUTION:

Because A/C condenser is attached to the front-lower portion of radiator, moving it in the rear direction should be at a minimum.

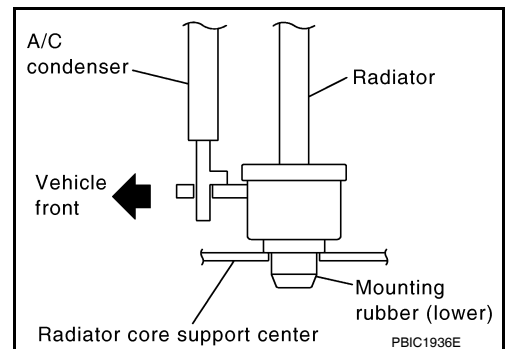

RADIATOR

[VQ40DE]

< ON-VEHICLE REPAIR >

- b. Lift A/C condenser up and remove radiator after disengaging the fitting at front-bottom surface.

CAUTION:

Lifting A/C condenser should be minimum to prevent a load to A/C piping.

- c. After removing radiator, put A/C condenser on radiator core support center to prevent a load to A/C piping, and temporarily fix it with rope or similar means.

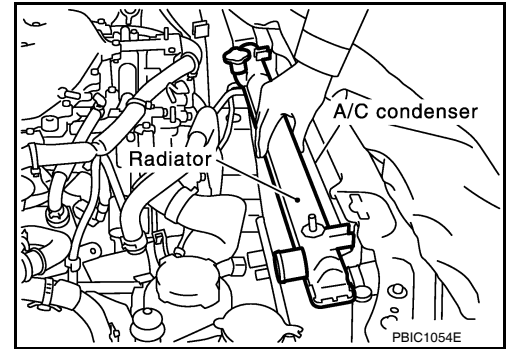

INSTALLATION

Installation is in the reverse order of removal.

INSPECTION AFTER INSTALLATION

- Check for leaks of engine coolant. Refer to [CO-11, "System Inspection"](#).
- Start and warm up engine. Visually check there are no leaks of engine coolant and A/T fluid.

Checking Radiator

INFOID:000000005260560

Check radiator for mud or clogging. If necessary, clean radiator as follows.

CAUTION:

- **Be careful not to bend or damage the radiator fins.**
 - **When radiator is cleaned without removal, remove all surrounding parts such as cooling fan, radiator shroud and horns. Then tape the harness and electrical connectors to prevent water from entering.**
1. Apply water by hose to the back side of the radiator core vertically downward.
 2. Apply water again to all radiator core surfaces.
 3. Stop washing when dirt and debris no longer flow out from the radiator.
 4. Blow air into the back side of radiator core vertically downward.
 - Use compressed air lower than 490 kPa (5 kg/cm², 71 psi) and keep distance more than 30 cm (11.8 in).
 5. Blow air again into all the radiator core surfaces until no water sprays out.
 6. Check for leaks.

ENGINE COOLING FAN

Exploded View

INFOID:000000005260561

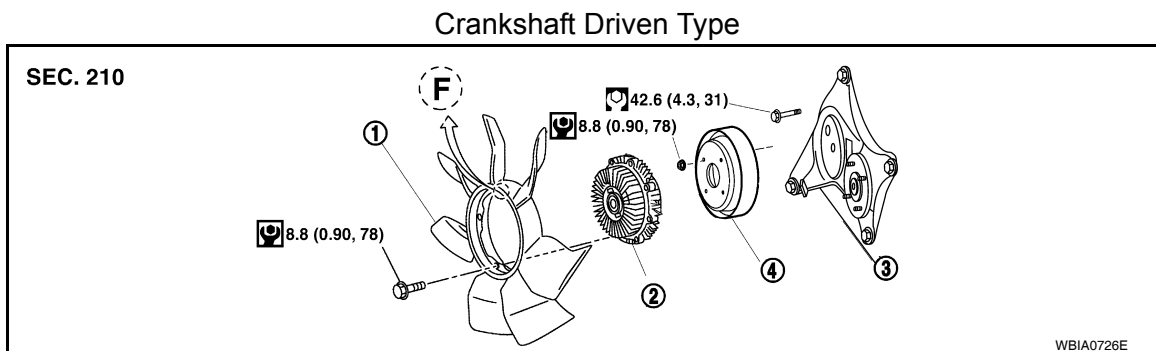

- | | | |
|-----------------------|-----------------|----------------|
| 1. Cooling fan | 2. Fan coupling | 3. Fan bracket |
| 4. Cooling fan pulley | | |

Removal and Installation (Crankshaft driven type)

INFOID:000000005260562

REMOVAL

1. Remove engine front undercover. Refer to [EXT-14. "Removal and Installation"](#).
2. Partially drain engine coolant from radiator. Refer to [CO-11](#).
CAUTION:
 - Perform this step when engine is cold.
 - Do not spill engine coolant on drive belts.
3. Remove the engine room cover. Refer to [EM-25. "Removal and Installation"](#).
4. Remove air duct and resonator assembly. Refer to [EM-26. "Removal and Installation"](#).
5. Remove reservoir tank hose from radiator.
6. Removal radiator hose (upper) from radiator.
CAUTION:
Do not spill engine coolant on drive belts.
7. Release the radiator shroud (lower) (2) from the radiator shroud (upper) (1) and position aside.
 - Release the tabs, pull radiator shroud (lower) (2) rearwards and down.

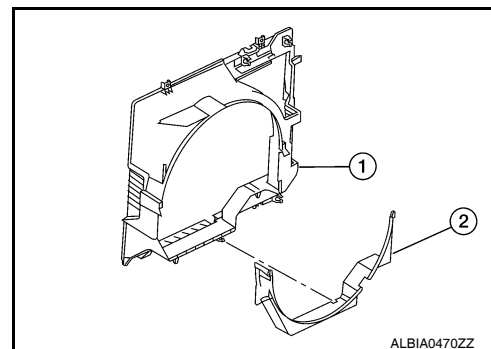

8. Remove the radiator shroud (upper) bolts and remove the radiator shroud (upper). Refer to [CO-16. "Exploded View"](#).
9. Remove the engine cooling fan (Motor driven type). Refer to [CO-20. "Removal and Installation \(Motor driven type\)"](#).
10. Remove the drive belt. Refer to [EM-14. "Removal and Installation"](#).
11. Remove the engine cooling fan.
12. Remove the fan coupling, if necessary.
13. Remove the cooling fan pulley, if necessary.
14. Remove the drive belt auto-tensioner, if necessary.
15. Remove the fan bracket, if necessary.

< ON-VEHICLE REPAIR >

INSPECTION AFTER REMOVAL

Fan Coupling

- Inspect fan coupling for oil leakage and bimetal conditions.
- If there are any unusual concerns, replace the fan coupling.

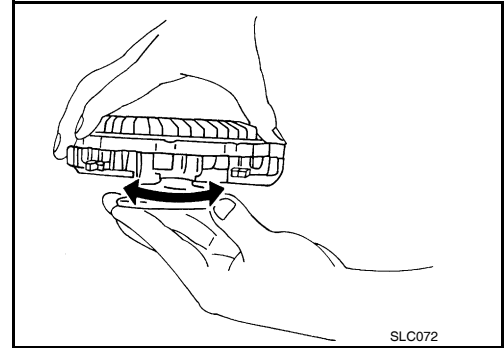

Fan Bracket

- Visually check that there is no significant looseness in the fan bracket shaft, and that it turns smoothly by hand.
- If there are any unusual concerns, replace the fan bracket assembly.

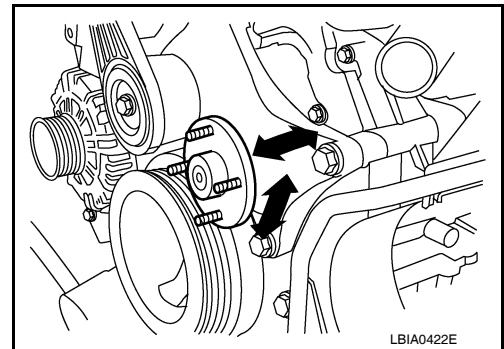

INSTALLATION

Installation is in the reverse order of removal.

- Install cooling fan with its front mark "F" facing front of engine. Refer to [CO-19. "Removal and Installation \(Crankshaft driven type\)"](#).

INSPECTION AFTER INSTALLATION

- Check for leaks of the engine coolant. Refer to [CO-11. "System Inspection"](#).
- Start and warm up the engine. Visually make sure that there are no leaks of the engine coolant.

Removal and Installation (Motor driven type)

INFOID:000000005260563

REMOVAL

1. Remove the engine under cover. Refer to [EXT-14. "Removal and Installation"](#).
2. Partially drain engine coolant from radiator. Refer to [CO-12. "Changing Engine Coolant"](#).
CAUTION:
 - Perform this step when engine is cold.
 - Do not spill engine coolant on drive belts.
3. Release the radiator shroud (lower) (2) from the radiator shroud (upper) (1) and position aside.
 - Release the tabs, pull radiator shroud (lower) (2) rearwards and down.

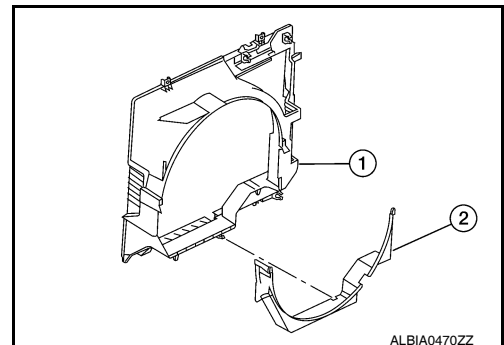

4. Remove engine room cover. Refer to [EM-25. "Removal and Installation"](#).
5. Remove air duct and resonator assembly. Refer to [EM-26. "Removal and Installation"](#).

ENGINE COOLING FAN

[VQ40DE]

< ON-VEHICLE REPAIR >

6. Remove upper radiator hose from radiator.
7. Remove reservoir tank hose from radiator shroud (upper) and radiator.
8. Remove the radiator shroud (upper) bolts and remove the radiator shroud (upper). Refer to [CO-16, "Exploded View"](#).
9. Disconnect harness connector from fan motor.
10. Remove the bolt and remove the fan grille and motor assembly.

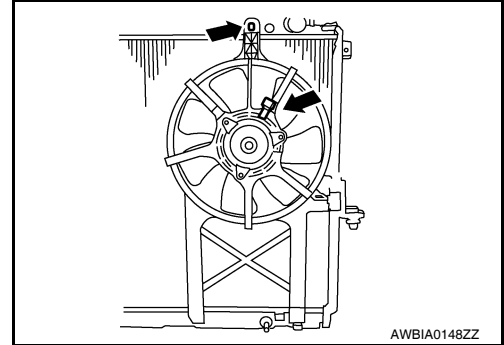

INSTALLATION

Installation is in the reverse order of removal.

- Cooling fan is controlled by ECM. For details, refer to [EC-318, "Diagnosis Procedure"](#).

A
CO
C
D
E
F
G
H
I
J
K
L
M
N
O
P

WATER PUMP

< ON-VEHICLE REPAIR >

[VQ40DE]

WATER PUMP

Exploded View

INFOID:000000005260564

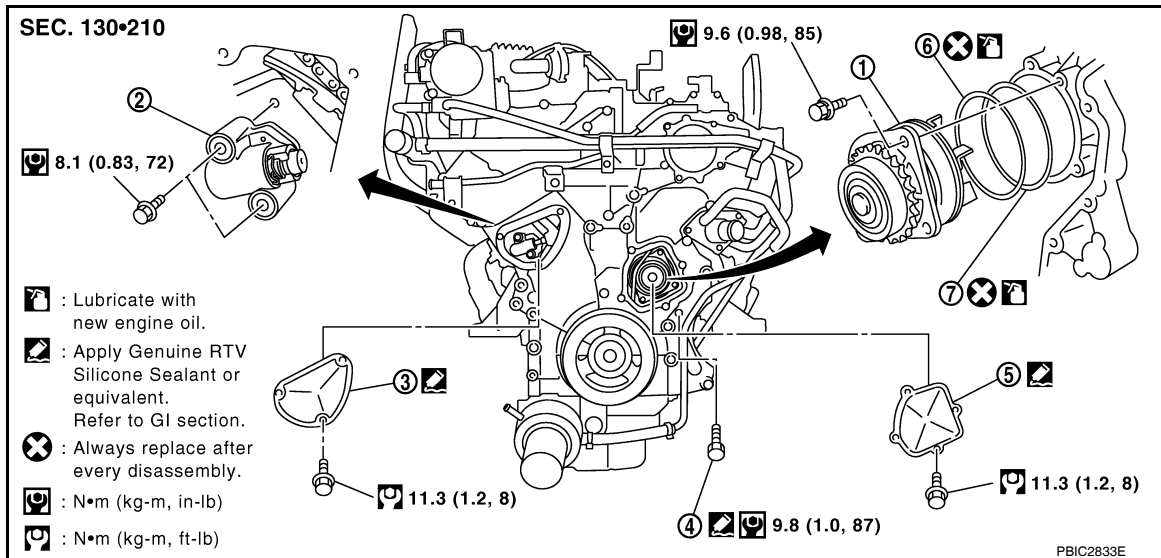

- | | | |
|-----------------------------|-------------------------------------|--------------------------|
| 1. Water pump | 2. Timing chain tensioner (primary) | 3. Chain tensioner cover |
| 4. Water drain plug (front) | 5. Water pump cover | 6. O-ring |
| 7. O-ring | | |

Removal and Installation

INFOID:000000005260565

CAUTION:

- When removing water pump assembly, be careful not to get engine coolant on timing chain and drive belt.
- Water pump cannot be disassembled and should be replaced as a unit.
- After installing water pump, connect hoses and clamps securely, then check for leaks.

REMOVAL

1. Remove engine front under cover. Refer to [EXT-14, "Removal and Installation"](#).
 2. Drain engine coolant. Refer to [CO-11](#).
 - Remove water drain plug (front).
- CAUTION:**
- Perform this step when engine is cold.
 - Do not spill engine coolant on timing chain and drive belt.
3. Remove the engine room cover. Refer to [EM-25, "Removal and Installation"](#).
 4. Remove air duct and resonator assembly. Refer to [EM-26, "Removal and Installation"](#).
 5. Remove drive belt. Refer to [EM-14, "Removal and Installation"](#).
 6. Remove radiator hose (upper).
 7. Remove coolant reservoir hose from the radiator.
 8. Remove engine cooling fan (motor driven type). Refer to [CO-20, "Removal and Installation \(Motor driven type\)"](#).
 9. Remove engine cooling fan (Crankshaft driven type) and fan bracket. Refer to [CO-19, "Removal and Installation \(Crankshaft driven type\)"](#).

WATER PUMP

[VQ40DE]

< ON-VEHICLE REPAIR >

10. Remove chain tensioner cover and water pump cover from front timing chain case, using Tool.

Tool number : KV10111100 (J-37228)

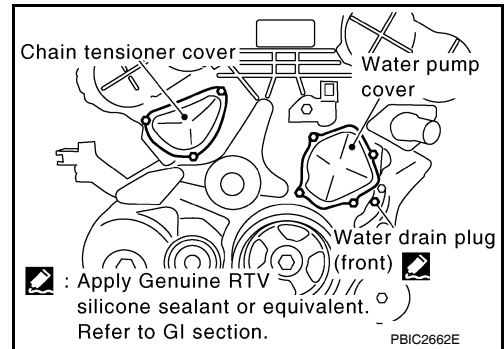

11. Remove timing chain tensioner (primary) as follows:

- Loosen clip of timing chain tensioner (primary), and release plunger stopper (1).
- Insert plunger into tensioner body by pressing slack guide (2).
- Keep slack guide pressed and hold plunger in by pushing stopper pin through the tensioner body hole and plunger groove (3).

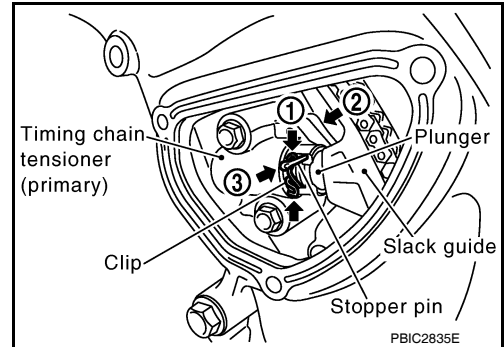

- Turn crankshaft pulley clockwise so that timing chain on the timing chain tensioner (primary) side is loose.

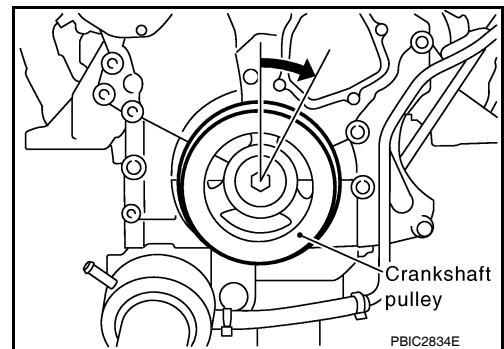

- Remove bolts and remove timing chain tensioner (primary).
CAUTION:
Be careful not to drop bolts inside timing chain case.

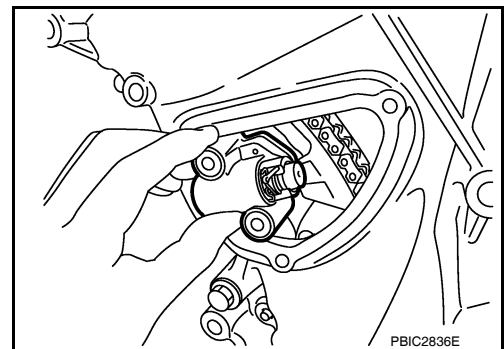

12. Remove water pump as follows:

WATER PUMP

[VQ40DE]

< ON-VEHICLE REPAIR >

- a. Remove three water pump bolts. Secure a gap between water pump gear and timing chain, by turning crankshaft pulley counterclockwise until timing chain looseness on water pump sprocket becomes maximum.

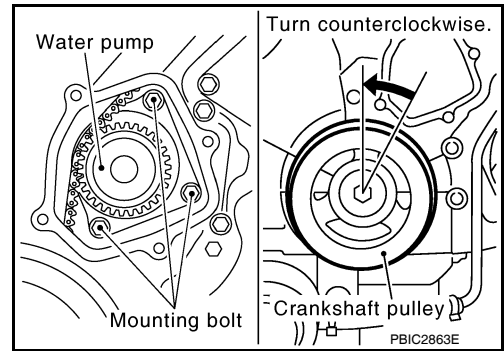

- b. Screw M8 bolts [pitch: 1.25 mm (0.049 in) length: approx. 50 mm (1.97 in)] into water pumps upper and lower bolt holes until they reach timing chain case. Then, alternately tighten each bolt for a half turn, and pull out water pump.

CAUTION:

- Pull straight out while preventing vane from contacting socket in installation area.
- Remove water pump without causing sprocket to contact timing chain.
- Do not spill engine coolant into timing chain case.

- c. Remove M8 bolts and O-rings from water pump.

CAUTION:

Do not disassemble water pump.

NOTE:

Do not reuse O-rings.

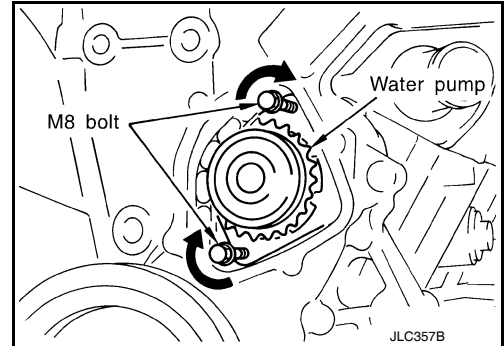

INSPECTION AFTER REMOVAL

- Visually check that there is no significant dirt or rust on the water pump body and vane.
- Make sure there is no looseness in the vane shaft, and that it turns smoothly when rotated by hand.
- Replace water pump, if necessary.

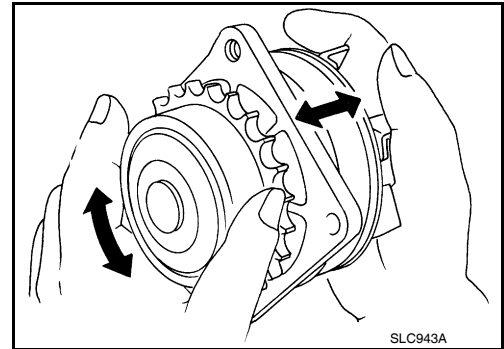

INSTALLATION

1. Install new O-rings to water pump.

NOTE:

- Apply engine oil to O-rings.
- Locate O-ring with white paint mark to engine front side.

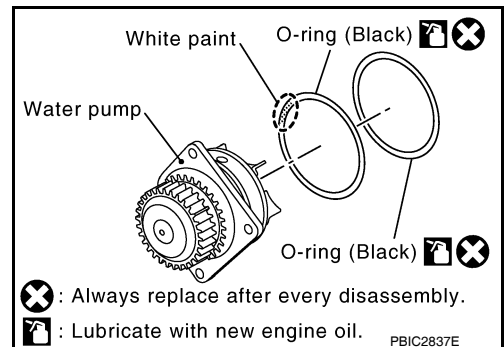

WATER PUMP

< ON-VEHICLE REPAIR >

[VQ40DE]

2. Install water pump.

CAUTION:

Do not allow timing chain case to pinch O-rings when installing water pump.

- Make sure that timing chain and water pump sprocket are engaged.
- Insert water pump by tightening bolts alternately and evenly.

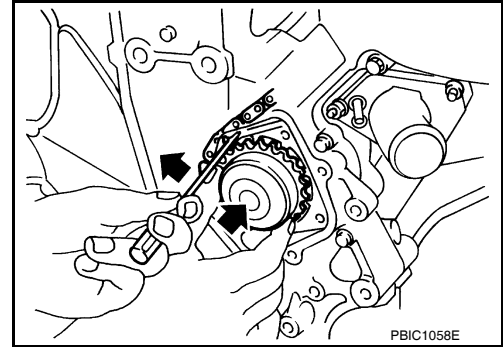

3. Install timing chain tensioner (primary) as follows:

- Remove dust and foreign material completely from backside of timing chain tensioner (primary) and from installation area of rear timing chain case.
- Turn crankshaft pulley clockwise so that timing chain on the timing chain tensioner (primary) side is loose.
- Install timing chain tensioner (primary) with its stopper pin attached.

CAUTION:

Be careful not to drop bolts inside timing chain case.

- Remove stopper pin.

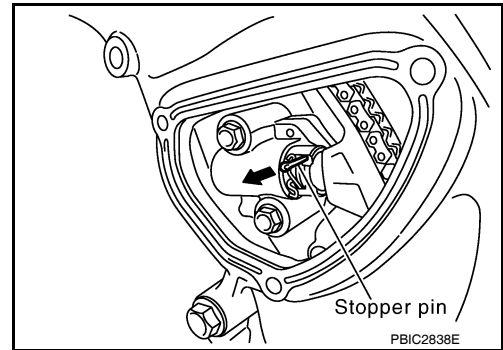

- Make sure again that timing chain and water pump sprocket are engaged.

4. Install chain tensioner cover and water pump cover as follows:

- Before installing, remove all traces of old liquid gasket from mating surface of water pump cover and chain tensioner cover using scraper. Also remove traces of old liquid gasket from the mating surface of front timing chain case.

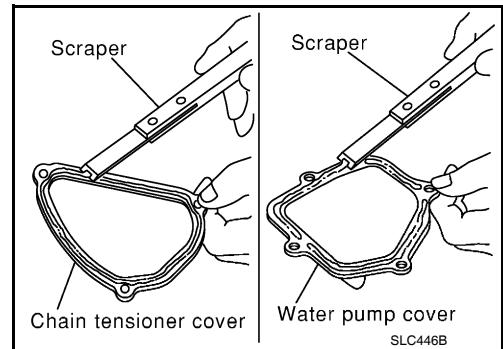

- Apply a continuous bead of liquid gasket, to mating surface of chain tensioner and water pump cover, using Tool.

Tool number : WS39930000 (—)

Use Genuine RTV Silicone Sealant or equivalent. Refer to GI-14, "Recommended Chemical Products and Sealants".

CAUTION:

Attaching should be done within 5 minutes after coating.

- Tighten bolts to specified torque. Refer to [EM-51, "Exploded View"](#).

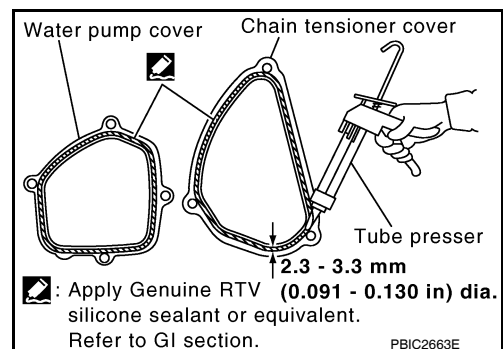

WATER PUMP

< ON-VEHICLE REPAIR >

[VQ40DE]

5. Installation of the remaining components is in the reverse order of removal.
 - Refill engine coolant system. Refer to [CO-12, "Changing Engine Coolant"](#).
 - Apply liquid gasket to the thread of water drain plug (front).
Use Genuine RTV Silicone Sealant or equivalent. Refer to [GI-14, "Recommended Chemical Products and Sealants"](#).
 - **After starting engine, let idle for three minutes, then rev engine up to 3,000 rpm under no load to purge air from the high-pressure chamber of chain tensioner. Engine may produce a rattling noise. This indicates that air still remains in the chamber and is not a matter of concern.**

INSPECTION AFTER INSTALLATION

- Check for leaks of engine coolant. Refer to [CO-11, "System Inspection"](#).
- Start and warm up engine. Visually check for leaks of engine coolant.

WATER INLET AND THERMOSTAT ASSEMBLY

< ON-VEHICLE REPAIR >

[VQ40DE]

WATER INLET AND THERMOSTAT ASSEMBLY

Exploded View

INFOID:000000005260566

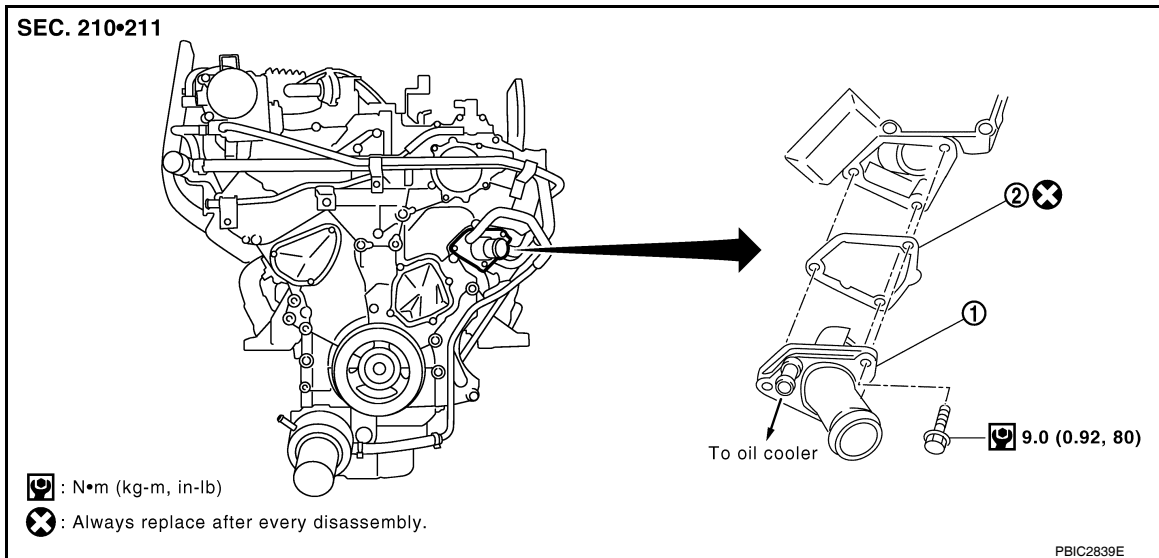

1. Water inlet and thermostat assembly
2. Gasket

Removal and Installation

INFOID:000000005260567

REMOVAL

1. Remove the engine under cover. Refer to [EXT-14. "Removal and Installation"](#).
2. Drain engine coolant from the radiator. Refer to [CO-12. "Changing Engine Coolant"](#).
CAUTION:
 - Perform this step when engine is cold.
 - Do not spill engine coolant on drive belts.
3. Remove air duct and resonator assembly and air cleaner case (upper). Refer to [EM-26. "Removal and Installation"](#).
4. Remove the radiator hose (upper) from the radiator.
5. Remove the coolant reservoir hose from the radiator.
6. Remove the fan shroud (lower) and (upper). Refer to [CO-16. "Exploded View"](#).
7. Disconnect radiator hose (lower) and oil cooler hose from water inlet and thermostat assembly.
8. Remove water inlet and thermostat assembly.
CAUTION:
 - Do not disassemble water inlet and thermostat assembly.
 - Replace water inlet and thermostat assembly as a unit, if necessary.

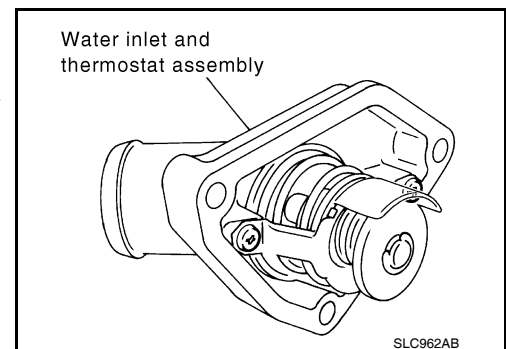

INSPECTION AFTER REMOVAL

1. Check valve seating condition at ordinary room temperatures. It should seat tightly.

WATER INLET AND THERMOSTAT ASSEMBLY

[VQ40DE]

< ON-VEHICLE REPAIR >

2. Check valve operation.
 - Place a thread so that it is caught in the valve of the thermostat. Immerse fully in a container filled with water. Heat while stirring.
 - The valve opening temperature is the temperature at which the valve opens and falls from the thread.
 - Continue heating. Check the full-open lift amount.
 - After checking the full-open lift amount, lower the water temperature and check the valve closing temperature.

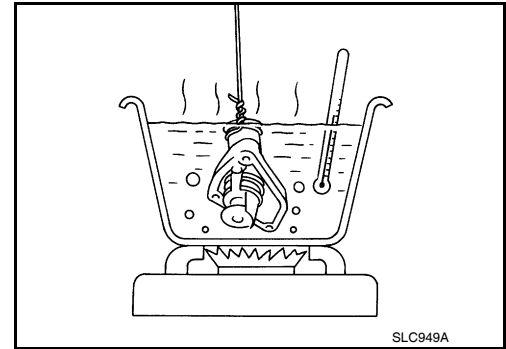

Thermostat	Standard
Valve opening temperature	80.5 - 83.5°C (177 - 182°F)
Full-open lift amount	8.6 mm / 95°C (0.339 in / 203°F)
Valve closing temperature	77°C (171°F)

- If valve seating at ordinary room temperature, or measured values are out of standard, replace water inlet and thermostat assembly.

INSTALLATION

Installation is in the reverse order of removal, paying attention to the following.

- **Do not spill engine coolant in engine room. Use rag to absorb engine coolant.**

INSPECTION AFTER INSTALLATION

- Check for leaks of engine coolant. Refer to [CO-11, "System Inspection"](#).
- Start and warm up engine. Visually check for leaks of engine coolant.

WATER OUTLET AND WATER PIPING

< ON-VEHICLE REPAIR >

[VQ40DE]

WATER OUTLET AND WATER PIPING

Exploded View

INFOID:000000005260568

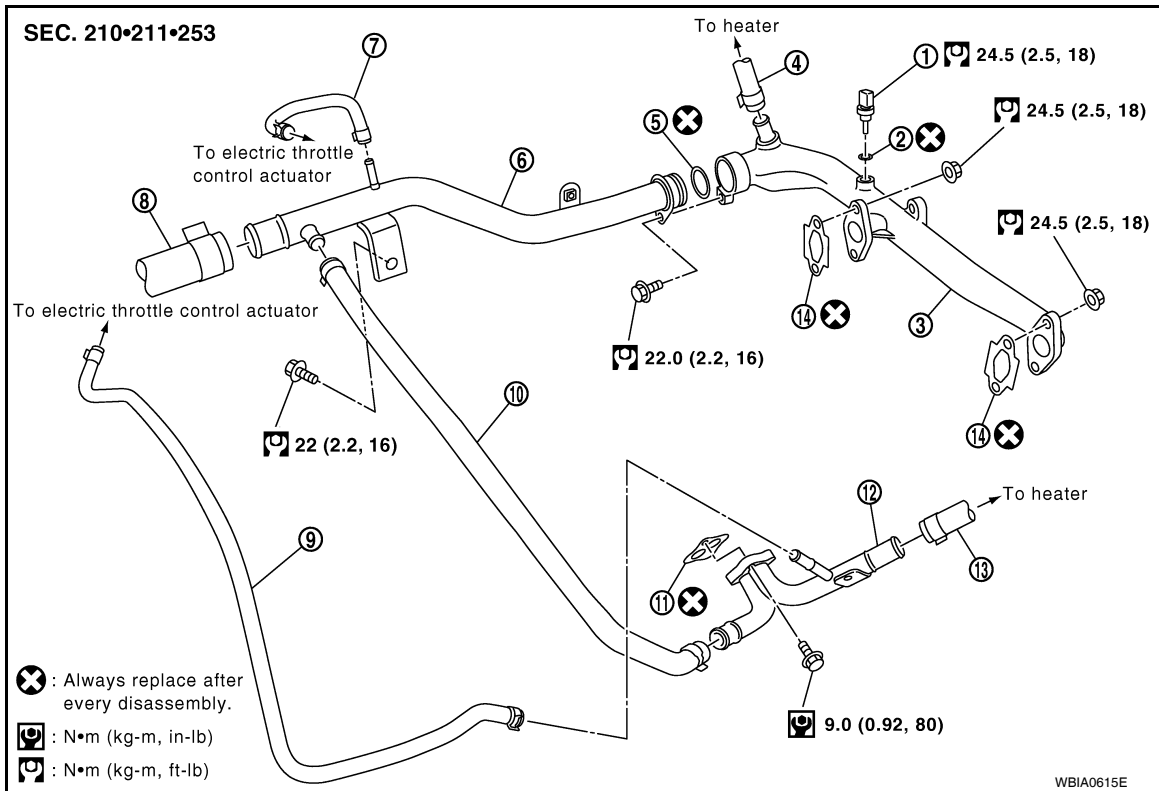

- | | | |
|--------------------------------------|--------------------------|-----------------|
| 1. Engine coolant temperature sensor | 2. Washer | 3. Water outlet |
| 4. Heater hose | 5. O-ring | 6. Water pipe |
| 7. Water hose | 8. Radiator hose (upper) | 9. Water hose |
| 10. Water hose | 11. Gasket | 12. Heater pipe |
| 13. Heater hose | 14. Gasket | |

Removal and Installation

INFOID:000000005260569

REMOVAL

1. Remove the engine under cover. Refer to [EXT-14, "Removal and Installation"](#).
2. Drain engine coolant from radiator. Refer to [CO-12, "Changing Engine Coolant"](#).

CAUTION:

- Perform this step when engine is cold.
- Do not spill engine coolant on drive belts.

3. Remove the intake manifold collector. Refer to [EM-27, "Removal and Installation"](#).
4. Remove engine coolant temperature sensor as necessary.

CAUTION:

Be careful not to damage engine coolant temperature sensor.

5. Remove water outlet, heater pipe, water bypass hoses and water pipe.

INSTALLATION

Installation is in the reverse order of removal, paying attention to the following.

- Securely insert each hose, and install clamp at a position where it does not interfere with the pipe bulge.
- When inserting water pipe into water outlet, apply neutral detergent to O-ring.

INSPECTION AFTER INSTALLATION

- Check for leaks of engine coolant. Refer to [CO-11, "System Inspection"](#).
- Start and warm up engine. Visually check for leaks of engine coolant.

SERVICE DATA AND SPECIFICATIONS (SDS)

< SERVICE DATA AND SPECIFICATIONS (SDS)

[VQ40DE]

SERVICE DATA AND SPECIFICATIONS (SDS)

SERVICE DATA AND SPECIFICATIONS (SDS)

Standard and Limit

INFOID:000000005260570

ENGINE COOLANT CAPACITY (APPROXIMATE)

Unit: ℓ (US qt, Imp qt)

Engine coolant capacity (With reservoir tank at "MAX" level)	Without rear A/C	10.2 (10-3/4, 9)
	With rear A/C	13.4 (14-1/8, 11-3/4)

RADIATOR

Unit: kPa (kg/cm², psi)

Reservoir cap relief pressure	Standard	98 - 118 (1.0 - 1.2, 14 - 17)
Leakage testing pressure		137 (1.4, 20)

THERMOSTAT

Valve opening temperature	80.5 - 83.5°C (177 - 182°F)
Full-open lift amount	8.6 mm / 95°C (0.339 in / 203°F)
Valve closing temperature	77°C (171°F)

PRECAUTION

PRECAUTIONS

Precaution for Supplemental Restraint System (SRS) "AIR BAG" and "SEAT BELT PRE-TENSIONER"

INFOID:000000005531979

The Supplemental Restraint System such as "AIR BAG" and "SEAT BELT PRE-TENSIONER", used along with a front seat belt, helps to reduce the risk or severity of injury to the driver and front passenger for certain types of collision. This system includes seat belt switch inputs and dual stage front air bag modules. The SRS system uses the seat belt switches to determine the front air bag deployment, and may only deploy one front air bag, depending on the severity of a collision and whether the front occupants are belted or unbelted. Information necessary to service the system safely is included in the SR and SB section of this Service Manual.

WARNING:

- To avoid rendering the SRS inoperative, which could increase the risk of personal injury or death in the event of a collision which would result in air bag inflation, all maintenance must be performed by an authorized NISSAN/INFINITI dealer.
- Improper maintenance, including incorrect removal and installation of the SRS, can lead to personal injury caused by unintentional activation of the system. For removal of Spiral Cable and Air Bag Module, see the SR section.
- Do not use electrical test equipment on any circuit related to the SRS unless instructed to in this Service Manual. SRS wiring harnesses can be identified by yellow and/or orange harnesses or harness connectors.

PRECAUTIONS WHEN USING POWER TOOLS (AIR OR ELECTRIC) AND HAMMERS

WARNING:

- When working near the Airbag Diagnosis Sensor Unit or other Airbag System sensors with the Ignition ON or engine running, DO NOT use air or electric power tools or strike near the sensor(s) with a hammer. Heavy vibration could activate the sensor(s) and deploy the air bag(s), possibly causing serious injury.
- When using air or electric power tools or hammers, always switch the Ignition OFF, disconnect the battery, and wait at least 3 minutes before performing any service.

Precaution Necessary for Steering Wheel Rotation After Battery Disconnect

INFOID:000000005260572

NOTE:

- This Procedure is applied only to models with Intelligent Key system and NATS (NISSAN ANTI-THEFT SYSTEM).
- Remove and install all control units after disconnecting both battery cables with the ignition knob in the "LOCK" position.
- Always use CONSULT-III to perform self-diagnosis as a part of each function inspection after finishing work. If DTC is detected, perform trouble diagnosis according to self-diagnostic results.

For models equipped with the Intelligent Key system and NATS, an electrically controlled steering lock mechanism is adopted on the key cylinder.

For this reason, if the battery is disconnected or if the battery is discharged, the steering wheel will lock and steering wheel rotation will become impossible.

If steering wheel rotation is required when battery power is interrupted, follow the procedure below before starting the repair operation.

OPERATION PROCEDURE

1. Connect both battery cables.

NOTE:

Supply power using jumper cables if battery is discharged.

2. Use the Intelligent Key or mechanical key to turn the ignition switch to the "ACC" position. At this time, the steering lock will be released.
3. Disconnect both battery cables. The steering lock will remain released and the steering wheel can be rotated.
4. Perform the necessary repair operation.

A
CO
C
D
E
F
G
H
I
J
K
L
M
N
O
P

PRECAUTIONS

[VK56DE]

< PRECAUTION >

- When the repair work is completed, return the ignition switch to the "LOCK" position before connecting the battery cables. (At this time, the steering lock mechanism will engage.)
- Perform a self-diagnosis check of all control units using CONSULT-III.

Precaution for Liquid Gasket

INFOID:000000005260573

REMOVAL OF LIQUID GASKET SEALING

- After removing nuts and bolts, separate the mating surface, using Tool and remove old liquid gasket sealing.

Tool number : KV10111100 (J-37228)

CAUTION:

Be careful not to damage the mating surfaces.

- Tap (1) Tool to insert it, and then slide (2) it by tapping on the side as shown.
- In areas where Tool is difficult to use, use plastic hammer to lightly tap the part, to remove it.

CAUTION:

If for some unavoidable reason suitable tool such as screwdriver is used, be careful not to damage the mating surfaces.

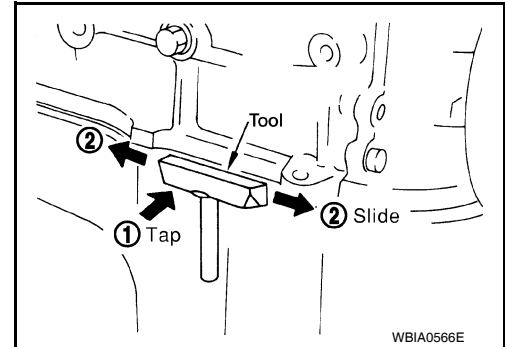

LIQUID GASKET APPLICATION PROCEDURE

- Remove the old liquid gasket adhering to the gasket application surface and the mating surface using suitable tool.
 - Remove the liquid gasket completely from the groove of the liquid gasket application surface, bolts, and bolt holes.
- Thoroughly clean the mating surfaces and remove adhering moisture, grease and foreign material.

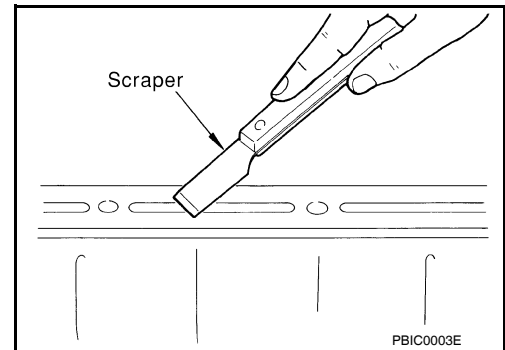

- Attach the liquid gasket tube to the Tool.

Tool number : WS39930000 (—)

Use Genuine RTV Silicone Sealant or equivalent. Refer to GI-14, "Recommended Chemical Products and Sealants".

- Apply the liquid gasket without breaks to the specified location with the specified dimensions.

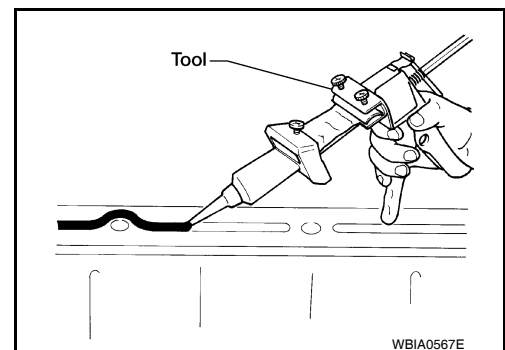

- If there is a groove for the liquid gasket application, apply the liquid gasket to the groove.
- As for the bolt holes, normally apply the liquid gasket inside the holes. If specified in the procedure, it should also be applied outside the holes.
- Within five minutes of liquid gasket application, install the mating component.
- If the liquid gasket protrudes, wipe it off immediately.
- Do not retighten after the installation.
- Wait 30 minutes or more after installation before refilling the engine with engine oil and engine coolant.

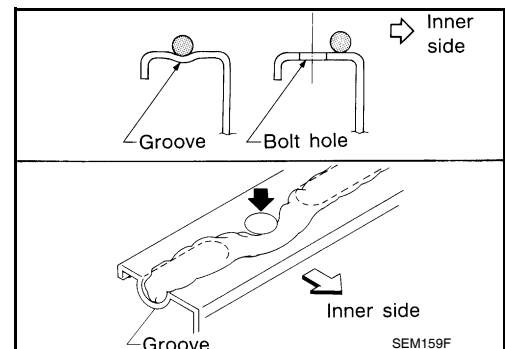

CAUTION:

If there are specific instructions in this manual, observe them.

PREPARATION

< PREPARATION >

[VK56DE]

PREPARATION

PREPARATION

Special Service Tool

INFOID:000000005260574

A

CO

The actual shapes of Kent-Moore tools may differ from those of special service tools illustrated here.

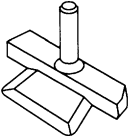
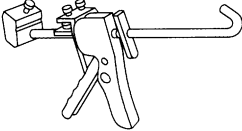
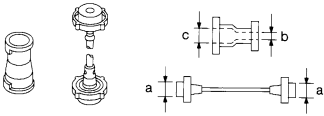
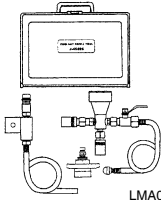
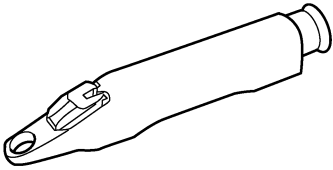
Tool number (Kent-Moore No.) Tool name	Description
KV10111100 (J-37228) Seal cutter	Removing steel oil pan and rear timing chain case  NT046
WS39930000 (—) Tube pressure	Pressing the tube of liquid gasket  S-NT052
EG17650301 (J-33984-A) Radiator cap tester adapter	Adapting radiator cap tester to radiator cap and radiator filler neck a: 28 (1.10) dia. b: 31.4 (1.236) dia. c: 41.3 (1.626) dia. Unit: mm (in)  S-NT564
KV991J0070 (J-45695) Coolant Refill Tool	Refilling engine cooling system  LMA053
— (J-23688) Engine coolant refractometer	Checking concentration of ethylene glycol in engine coolant  WBIA0539E

C

D

E

F

G

H

I

J

K

L

M

N

O

Commercial Service Tool

INFOID:000000005260575

P

PREPARATION

< PREPARATION >

[VK56DE]

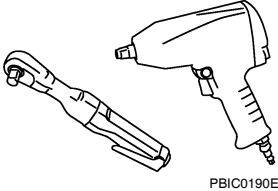
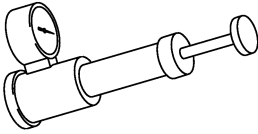
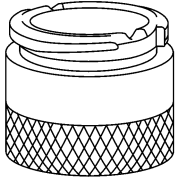
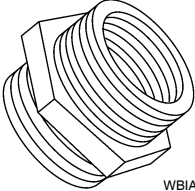
Tool name	Description
<p data-bbox="164 197 272 224">Power tool</p>  <p data-bbox="829 415 899 434">PBIC0190E</p>	<p data-bbox="1011 197 1263 224">Loosening bolts and nuts</p>
<p data-bbox="164 449 354 476">Radiator cap tester</p>  <p data-bbox="829 663 899 682">PBIC1982E</p>	<p data-bbox="1011 449 1360 476">Checking radiator and radiator cap</p>
<p data-bbox="164 701 464 728">Coolant system tester adapter</p>  <p data-bbox="829 917 899 936">WBIA0408E</p>	<p data-bbox="1011 701 1458 758">Adapting radiator cap tester to reservoir filler neck</p>
<p data-bbox="164 953 464 980">Coolant system tester adapter</p>  <p data-bbox="829 1167 899 1186">WBIA0409E</p>	<p data-bbox="1011 953 1458 980">Adapting radiator cap tester to reservoir cap</p>

FUNCTION DIAGNOSIS

COOLING SYSTEM

Cooling Circuit

INFOID:000000005260576

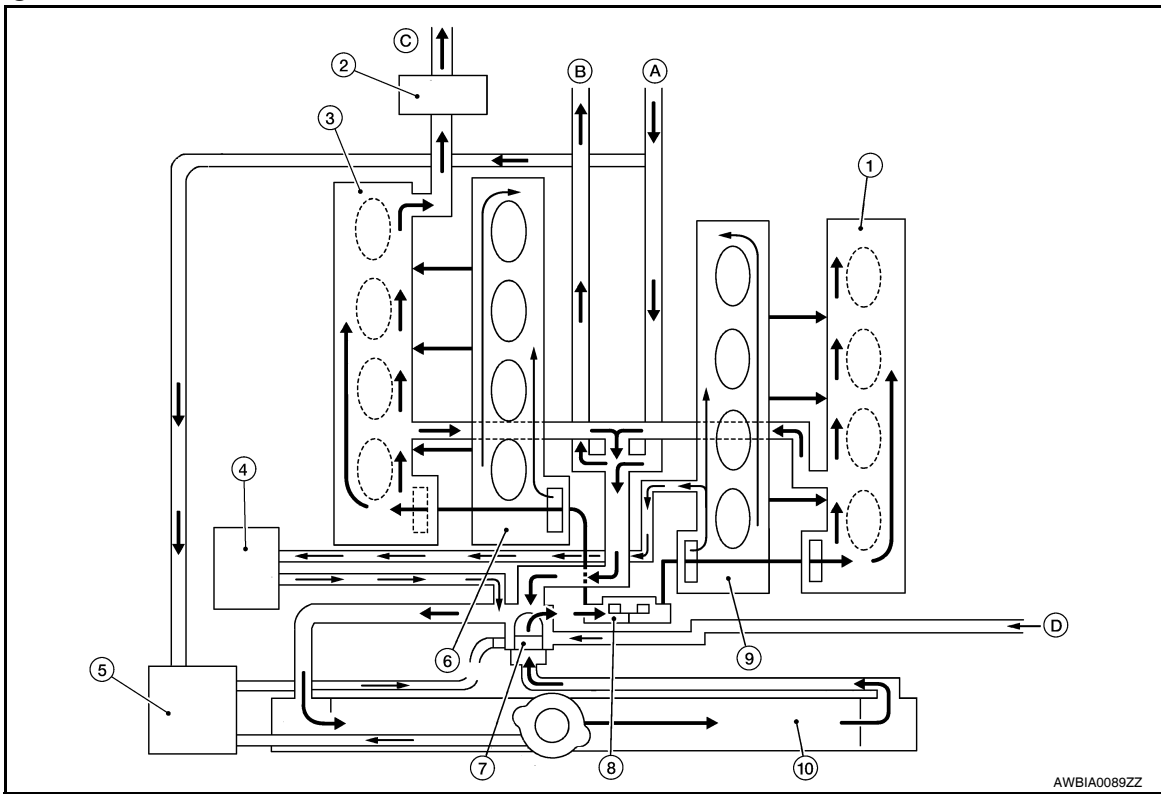

- | | | |
|-----------------------|--|--|
| 1. Cylinder head (LH) | 2. Water cut valve | 3. Cylinder head (RH) |
| 4. Oil cooler | 5. Reservoir tank | 6. Cylinder block (RH) |
| 7. Thermostat | 8. Water pump | 9. Cylinder block (LH) |
| 10. Radiator | A. From heater | B. To electronic throttle control actuator |
| C. To heater | D. From electronic throttle control actuator | |

COOLING SYSTEM

< FUNCTION DIAGNOSIS >

[VK56DE]

Schematic

INFOID:000000005260577

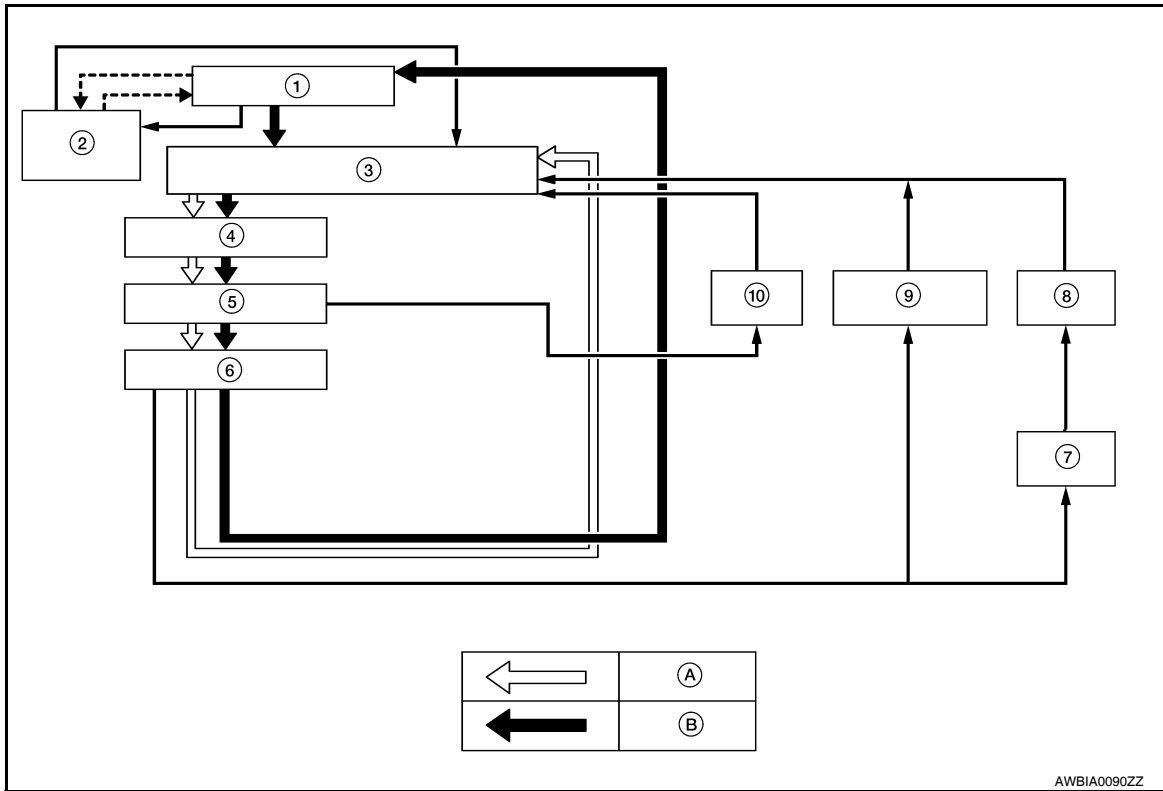

- | | | |
|--------------------|----------------------|---|
| 1. Radiator | 2. Reservoir tank | 3. Thermostat and thermostat housing |
| 4. Water pump | 5. Cylinder block | 6. Cylinder head |
| 7. Water cut valve | 8. Heater | 9. Electronic throttle control actuator |
| 10. Oil cooler | A. Thermostat closed | B. Thermostat open |

OVERHEATING CAUSE ANALYSIS

< FUNCTION DIAGNOSIS >

[VK56DE]

OVERHEATING CAUSE ANALYSIS

Troubleshooting Chart

INFOID:000000005260578

	Symptom		Check items	
Cooling system parts malfunction	Poor heat transfer	Water pump malfunction	Worn or loose drive belt	—
		Thermostat stuck closed	—	
		Damaged fins	Dust contamination or paper clogging	
			Physical damage	
		Clogged radiator cooling tube	Excess foreign material (rust, dirt, sand, etc.)	
	Water cut valve malfunction	Excess foreign material (rust, dirt, sand, etc.)	Physical damage	
	Reduced air flow	Cooling fan does not operate	Fan assembly	—
		High resistance to fan rotation		
		Damaged fan blades		
	Damaged radiator shroud	—	—	—
	Improper engine coolant mixture ratio	—	—	—
	Poor engine coolant quality	—	Engine coolant density	—
	Insufficient engine coolant	Engine coolant leaks	Cooling hose	Loose clamp
				Cracked hose
			Water pump	Poor sealing
		Radiator cap	Loose	
			Poor sealing	
		Radiator	O-ring for damage, deterioration or improper fitting	
Cracked radiator tank				
Cracked radiator core				
Reservoir tank	Cracked reservoir tank			
Overflowing reservoir tank	Exhaust gas leaks into cooling system	Cylinder head deterioration		
		Cylinder head gasket deterioration		

A
CO
C
D
E
F
G
H
I
J
K
L
M
N
O
P

OVERHEATING CAUSE ANALYSIS

< FUNCTION DIAGNOSIS >

[VK56DE]

		Symptom		Check items	
Except cooling system parts malfunction	—	Overload on engine	Abusive driving	High engine rpm under no load	—
				Driving in low gear for extended time	
				Driving at extremely high speed	
			Powertrain system malfunction		
			Installed improper size wheels and tires		
			Dragging brakes		
	Blocked or restricted air flow	Blocked or restricted air flow	Blocked bumper	—	—
			Blocked radiator grille	Installed car brassiere	
				Mud contamination or paper clogging	
			Blocked radiator	—	
Blocked condenser			Blocked air flow		
Installed large fog lamp					

ON-VEHICLE MAINTENANCE

ENGINE COOLANT

System Inspection

INFOID:000000005260579

WARNING:

- Never remove the radiator/reservoir cap when the engine is hot. Serious burns could occur from high pressure fluid escaping from the radiator or reservoir.
- Wrap a thick cloth around the cap. Slowly push down and turn it a quarter turn to allow built-up pressure to escape. Carefully remove the cap by pushing down and turning it all the way.

CHECKING COOLING SYSTEM HOSES

Check hoses for the following:

- Improper attachment
- Leaks
- Cracks
- Damage
- Loose connections
- Chafing
- Deterioration

CHECKING RESERVOIR LEVEL

- Check if the engine coolant reservoir tank level is within MIN to MAX level when the engine is cool.
- Adjust engine coolant level as necessary.

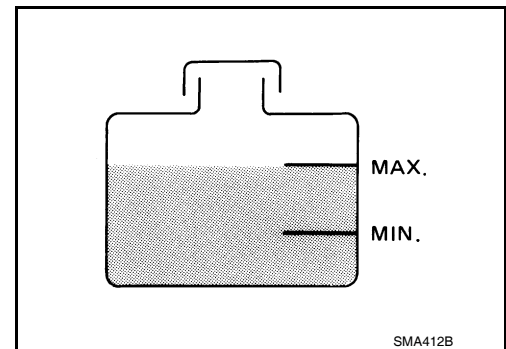

CHECKING COOLING SYSTEM FOR LEAKS

WARNING:

Never remove the radiator/reservoir cap when the engine is hot. Serious burns could occur from high-pressure engine coolant escaping from the radiator or reservoir.

- To check for leakage, apply pressure to the cooling system at the reservoir filler neck using suitable tool and Tool.

Tool number : EG17650301 (J-33984-A)

Leakage test pressure : 137 kPa (1.4 kg/cm, 20 psi)

CAUTION:

Higher pressure than specified may cause radiator damage.

NOTE:

In case that engine coolant decreases, replenish cooling system with engine coolant.

- If any concerns are found, repair or replace damaged parts.

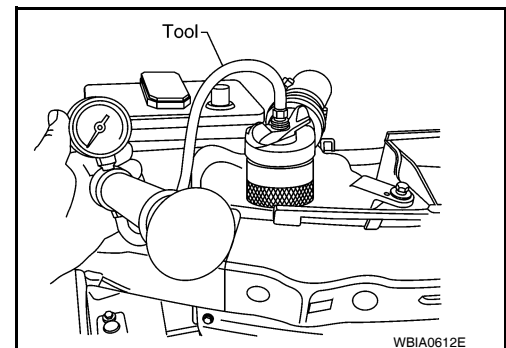

CHECKING RESERVOIR CAP

ENGINE COOLANT

< ON-VEHICLE MAINTENANCE >

[VK56DE]

- Check reservoir cap relief pressure using suitable tool and Tool.

Tool number : EG17650301 (J-33984-A)

Standard : 98 - 118 kPa (1.0 - 1.2 kg/cm², 14 - 17 psi)

NOTE:

- Apply engine coolant to the cap seal.
- Replace the reservoir cap if there is any damage in the negative-pressure valve, or if the open-valve pressure is outside of the limit.

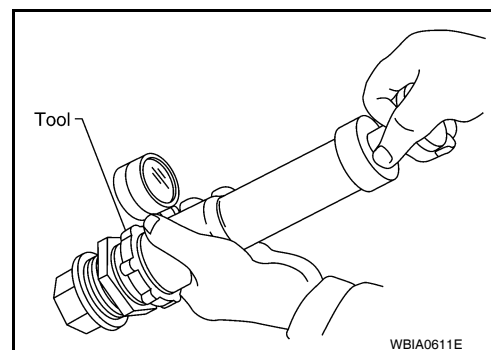

CHECKING RADIATOR CAP

Inspect the radiator cap.

NOTE:

Thoroughly wipe out the radiator filler neck to remove any waxy residue or foreign material.

- Replace the cap if the metal plunger cannot be seen around the edge of the black rubber gasket.
- Replace the cap if deposits of waxy residue or other foreign material are on the black rubber gasket or the metal retainer.

CHECKING RADIATOR

Check radiator for mud or clogging. If necessary, clean radiator as follows.

CAUTION:

- **Be careful not to bend or damage the radiator fins.**
 - **When radiator is cleaned without removal, remove all surrounding parts such as cooling fan shroud and horns. Then tape the harness and electrical connectors to prevent water from entering.**
1. Apply water by hose to the back side of the radiator core, with the hose pointed vertically downward.
 2. Apply water again to all radiator core surfaces once per minute.
 3. Stop washing if any stains no longer flow out from the radiator.
 4. Blow air into the back side of radiator core, with the air hose pointed vertically downward.
 - Use compressed air lower than 490 kPa (5 kg/cm², 71 psi) and keep distance more than 30 cm (11.8 in).
 5. Blow air again into all the radiator core surfaces once per minute until no water sprays out.
 6. Check for leaks.

Changing Engine Coolant

INFOID:000000005260580

WARNING:

- **To avoid being scalded, never change the coolant when the engine is hot.**
- **Wrap a thick cloth around the cap to carefully remove the cap. First, turn the cap a quarter of a turn to release any built-up pressure, then push down and turn the cap all the way to remove it.**

DRAINING ENGINE COOLANT

1. Turn ignition switch ON and set temperature control lever all the way to HOT position or the highest temperature position. Wait 10 seconds and turn ignition switch OFF.
2. Remove the engine front undercover using power tool.
3. Open the radiator drain plug at the bottom of the radiator, and remove the reservoir cap. This is the only step required when partially draining the cooling system (radiator only).

CAUTION:

Do not allow the coolant to contact the drive belts.

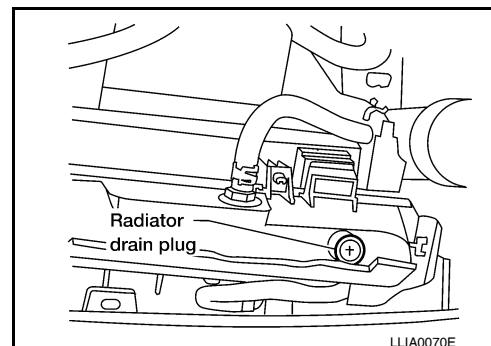

ENGINE COOLANT

< ON-VEHICLE MAINTENANCE >

[VK56DE]

- When draining all of the coolant in the system for engine removal or repair, it is necessary to drain the cylinder block. Remove the RH cylinder block drain plug to drain the right bank, the oil cooler hose to drain the left bank as shown and the block heater if equipped.

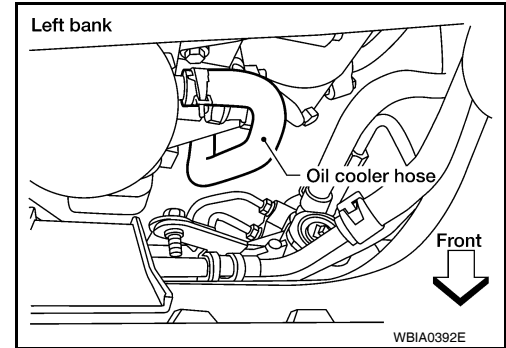
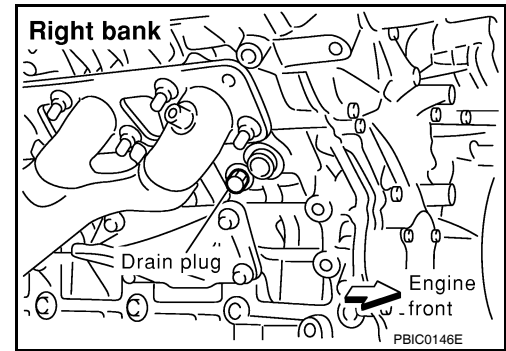

- Remove the reservoir tank to drain the engine coolant, then clean the reservoir tank before installing it.
- Check the drained coolant for contaminants such as rust, corrosion or discoloration. If the coolant is contaminated, flush the engine cooling system. Refer to [CO-40. "Changing Engine Coolant"](#).

REFILLING ENGINE COOLANT

- Close the radiator drain plug. Install the reservoir tank, cylinder block drain plug, the oil cooler hose and block heater if equipped, if removed for a total system drain or for engine removal or repair.
 - The radiator must be completely empty of coolant and water.
 - Apply sealant to the threads of the cylinder block drain plug. Use Genuine High Performance Thread Sealant or equivalent. Refer to [GI-14. "Recommended Chemical Products and Sealants"](#).

Radiator drain plug : Refer to [CO-40. "Changing Engine Coolant"](#).

RH cylinder block drain plug : Refer to [EM-219. "Disassembly and Assembly"](#).

- Set the vehicle heater controls to the full HOT and heater ON position. Turn the vehicle ignition ON with the engine OFF as necessary to activate the heater mode.
- Remove the vented reservoir cap and replace it with a non-vented reservoir cap before filling the cooling system.

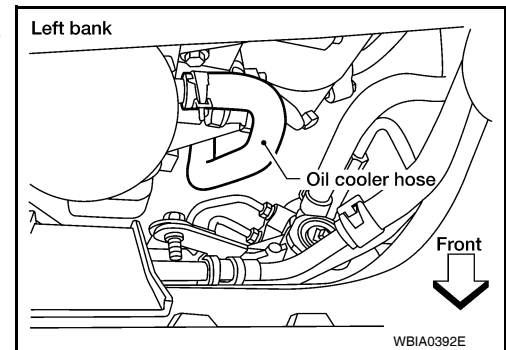

ENGINE COOLANT

[VK56DE]

< ON-VEHICLE MAINTENANCE >

4. Install the Tool by installing the radiator cap adapter onto the radiator neck opening. Then attach the gauge body assembly with the refill tube and the venturi assembly to the radiator cap adapter.

Tool number : KV991J0070 (J-45695)

5. Insert the refill hose into the coolant mixture container that is placed at floor level. Make sure the ball valve is in the closed position.
 - Use recommended coolant or equivalent. Refer to [MA-16, "For North America"](#).

Cooling system capacity (with reservoir) : Refer to [MA-16, "For North America"](#).

6. Install an air hose to the venturi assembly, the air pressure must be within specification.

Compressed air supply pressure : 549 - 824 kPa (5.6 - 8.4 kg/cm², 80 - 119 psi)

CAUTION:

The compressed air supply must be equipped with an air dryer.

7. The vacuum gauge will begin to rise and there will be an audible hissing noise. During this process open the ball valve on the refill hose slightly. Coolant will be visible rising in the refill hose. Once the refill hose is full of coolant, close the ball valve. This will purge any air trapped in the refill hose.

8. Continue to draw the vacuum until the gauge reaches 28 inches of vacuum. The gauge may not reach 28 inches in high altitude locations, use the vacuum specifications based on the altitude above sea level.

Altitude above sea level	Vacuum gauge reading
0 - 100 m (328 ft)	: 28 inches of vacuum
300 m (984 ft)	: 27 inches of vacuum
500 m (1,641 ft)	: 26 inches of vacuum
1,000 m (3,281 ft)	: 24 - 25 inches of vacuum

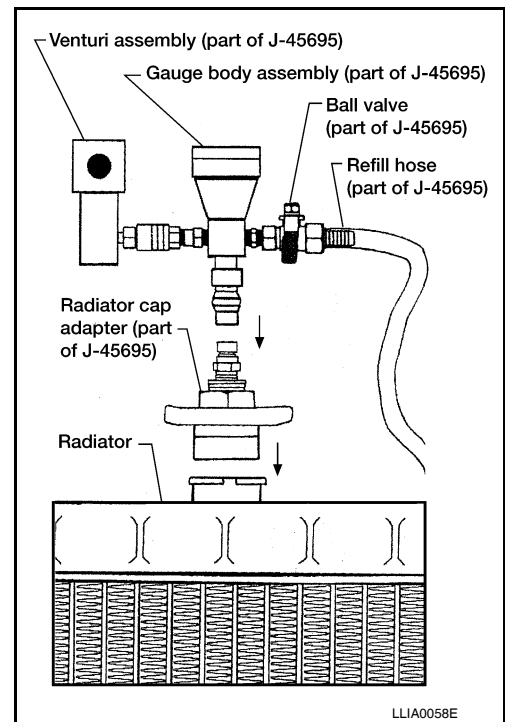

LLIA0058E

9. When the vacuum gauge has reached the specified amount, disconnect the air hose and wait 20 seconds to see if the system loses any vacuum. If the vacuum level drops, perform any necessary repairs to the system and repeat steps 6 - 8 to bring the vacuum to the specified amount. Recheck for any leaks.
10. Place the coolant container (with the refill hose inserted) at the same level as the top of the radiator. Then open the ball valve on the refill hose so the coolant will be drawn up to fill the cooling system. The cooling system is full when the vacuum gauge reads zero.

CAUTION:

Do not allow the coolant container to get too low when filling, to avoid air from being drawn into the cooling system.

11. Remove the Tool from the radiator neck opening and install the radiator cap.
12. Remove the non-vented reservoir cap.
13. Fill the cooling system reservoir tank to the specified level. Run the engine to warm up the cooling system and top up the system as necessary before installing the vented reservoir cap.

FLUSHING COOLING SYSTEM

1. Drain the water from the engine cooling system. Refer to [CO-12, "Changing Engine Coolant"](#).
2. Fill the radiator and the reservoir tank (to the "MAX" line), with water. Reinstall the radiator cap and leave the vented reservoir cap off.

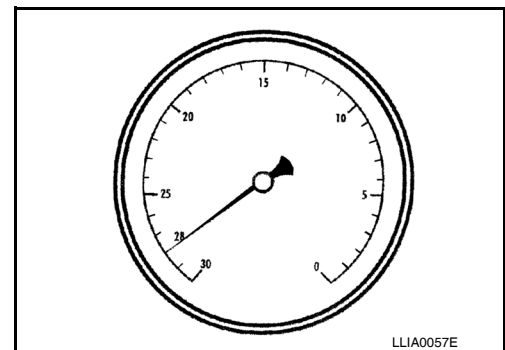

LLIA0057E

ENGINE COOLANT

< ON-VEHICLE MAINTENANCE >

[VK56DE]

3. Run the engine until it reaches normal operating temperature.
4. Press the engine accelerator two or three times under no-load.
5. Stop the engine and wait until it cools down.
6. Drain the water from the engine cooling system. Refer to [CO-12. "Changing Engine Coolant"](#).
7. Repeat steps 2 through 6 until clear water begins to drain from the radiator.

A

CO

C

D

E

F

G

H

I

J

K

L

M

N

O

P

RADIATOR

< ON-VEHICLE REPAIR >

[VK56DE]

ON-VEHICLE REPAIR

RADIATOR

Exploded View

INFOID:000000005260581

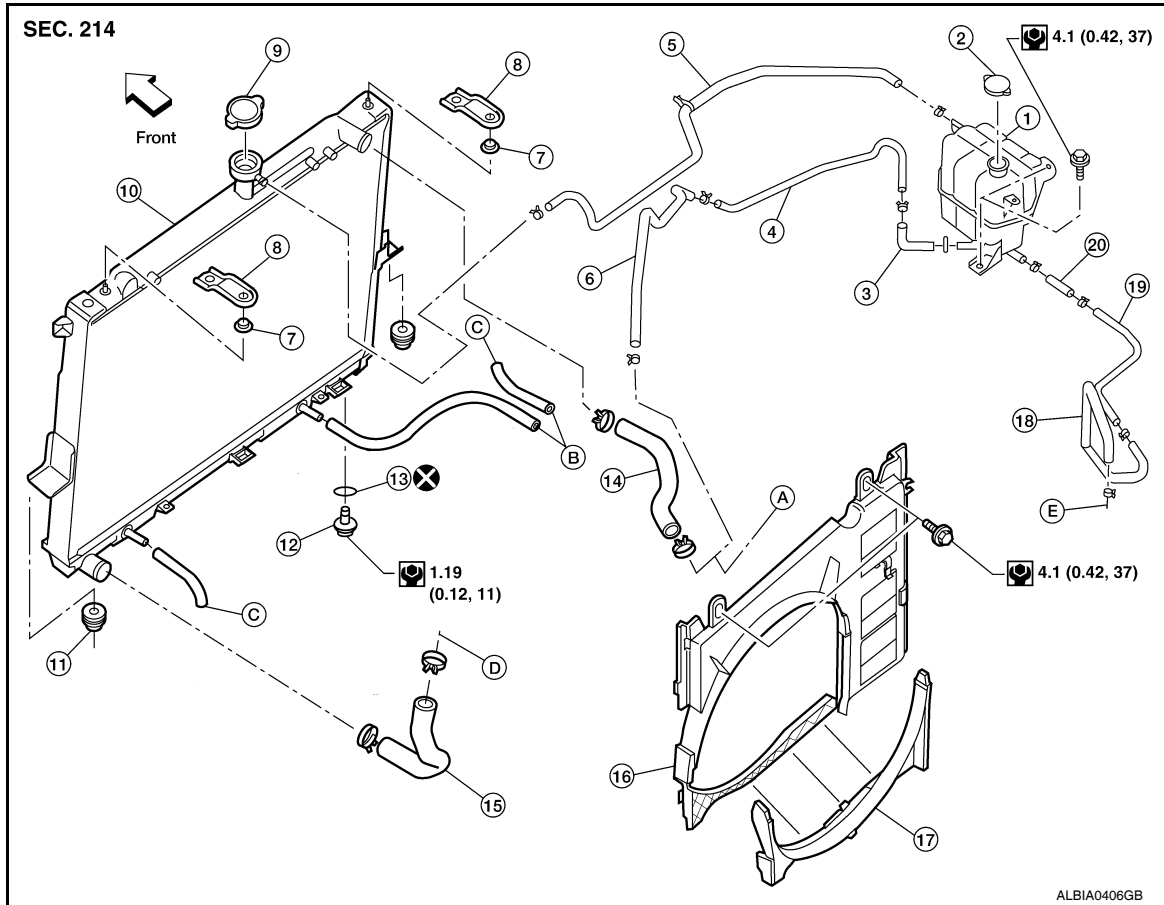

- | | | |
|-----------------------------|-------------------------------------|---------------------------|
| 1. Reservoir tank | 2. Reservoir tank cap | 3. By-pass hose |
| 4. By-pass tube | 5. Reservoir tank hose | 6. By-pass hose |
| 7. Mounting rubber (upper) | 8. Upper mount bracket | 9. Radiator cap |
| 10. Radiator | 11. Mounting rubber (lower) | 12. Radiator drain plug |
| 13. O-ring | 14. Radiator hose (upper) | 15. Radiator hose (lower) |
| 16. Radiator shroud (upper) | 17. Radiator shroud (lower) | 18. Heater by-pass hose |
| 19. Heater by-pass tube | 20. Heater by-pass hose | A. To thermostat housing |
| B. To A/T fluid cooler tube | C. To transmission auxiliary cooler | D. To water suction pipe |
| E. To heater tube | | |
- ← Front

Removal and Installation

INFOID:000000005260582

WARNING:

Do not remove radiator cap when engine is hot. Serious burns could occur from high-pressure engine coolant escaping from radiator. Wrap a thick cloth around the cap. Slowly turn it a quarter of a turn to release built-up pressure. Carefully remove radiator cap by turning it all the way.

REMOVAL

1. Remove engine front under cover. Refer to [EXT-14. "Removal and Installation"](#).
2. Drain engine coolant from radiator. Refer to [CO-11](#).

CAUTION:

RADIATOR

[VK56DE]

< ON-VEHICLE REPAIR >

- Perform this step when engine is cold.
 - Do not spill engine coolant on drive belts.
3. Remove air duct and resonator assembly. Refer to [EM-161. "Removal and Installation"](#).
 4. Remove reservoir tank hoses.
NOTE:
 - Remove reservoir tank hose from radiator.
 - Remove reservoir tank return hose from engine.
 5. Removal radiator hoses (upper and lower).
CAUTION:
Be careful not to allow engine coolant to contact drive belts.
 6. Disconnect A/T fluid cooler hoses.
 - Install blind plug to avoid leakage of A/T fluid.
 7. Remove the radiator shroud (lower).
 - Release the tabs, pull radiator shroud (lower) rearwards and down to remove.

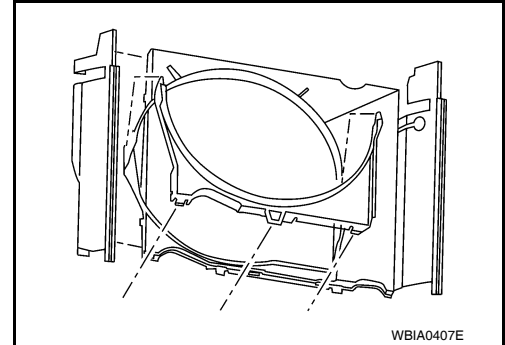

8. Remove the radiator shroud (upper) bolts and remove the radiator shroud (upper) (A).

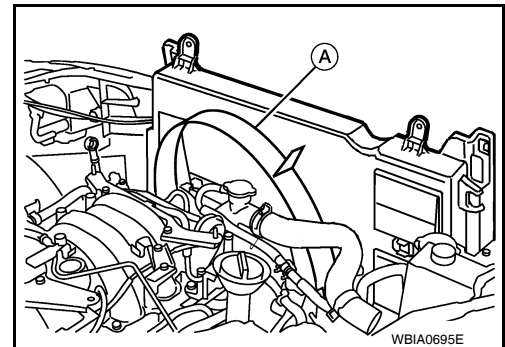

9. Remove the engine cooling fan (crankshaft driven type). Refer to [CO-48. "Removal and Installation \(Crankshaft Driven Type\)"](#).
10. Remove front grille. Refer to [EXT-18. "Removal and Installation"](#).
11. Remove the upper mount bracket bolts.

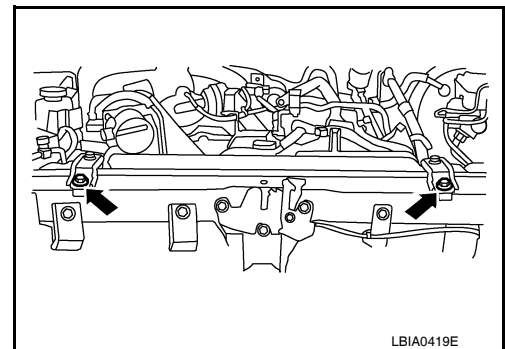

A
CO
C
D
E
F
G
H
I
J
K
L
M
N
O
P

RADIATOR

< ON-VEHICLE REPAIR >

[VK56DE]

12. Remove the two A/C condenser bolts.

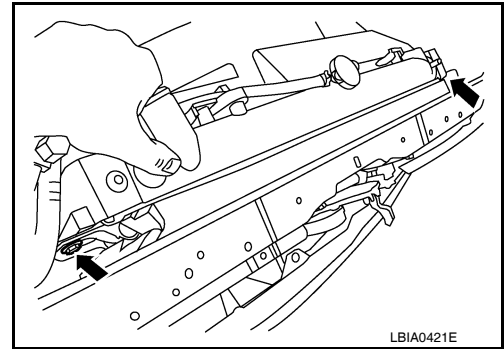

13. Remove radiator as follows:

CAUTION:

Do not damage or scratch A/C condenser and radiator core when removing.

a. With lifting and pulling radiator in a rear direction, disassemble mounting rubber (lower) from radiator core support center.

CAUTION:

Because A/C condenser is attached to the front-lower portion of radiator, moving it in the rear direction should be at minimum.

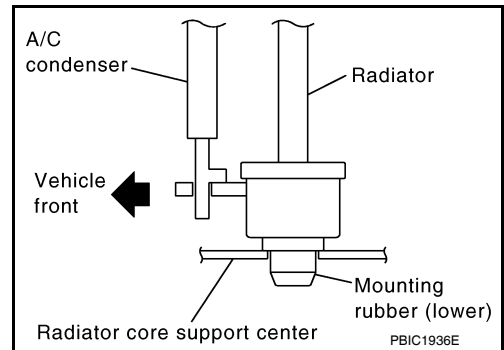

b. Lift A/C condenser up and remove radiator after disengaging the fitting at front-bottom surface.

CAUTION:

Lifting A/C condenser should be minimum to prevent a load to A/C piping.

c. After removing radiator, put A/C condenser on radiator core support center to prevent a load to A/C piping, and temporarily fix it with rope or similar means.

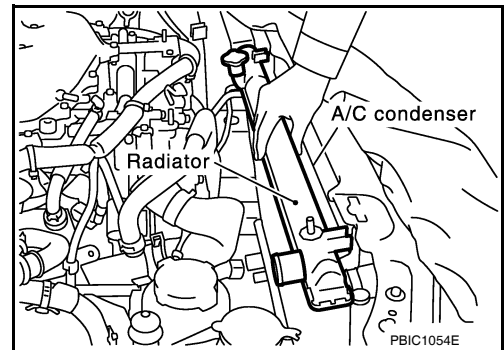

INSTALLATION

Installation is in the reverse order of removal.

INSPECTION AFTER INSTALLATION

- Check for leaks of engine coolant. Refer to [CO-11, "System Inspection"](#).
- Start and warm up engine. Visually check there are no leaks of engine coolant and A/T fluid.

Checking Radiator

INFOID:000000005260583

Check radiator for mud or clogging. If necessary, clean radiator as follows.

CAUTION:

- **Be careful not to bend or damage the radiator fins.**
- **When radiator is cleaned without removal, remove all surrounding parts such as cooling fan, radiator shroud and horns. Then tape the harness and electrical connectors to prevent water from entering.**

1. Apply water by hose to the back side of the radiator core vertically downward.
2. Apply water again to all radiator core surfaces.
3. Stop washing when dirt and debris no longer flow out from the radiator.
4. Blow air into the back side of radiator core vertically downward.
 - Use compressed air lower than 490 kPa (5 kg/cm², 71 psi) and keep distance more than 30 cm (11.8 in).

RADIATOR

< ON-VEHICLE REPAIR >

[VK56DE]

5. Blow air again into all the radiator core surfaces until no water sprays out.
6. Check for leaks.

A

CO

C

D

E

F

G

H

I

J

K

L

M

N

O

P

ENGINE COOLING FAN

< ON-VEHICLE REPAIR >

[VK56DE]

ENGINE COOLING FAN

Exploded View

INFOID:000000005260584

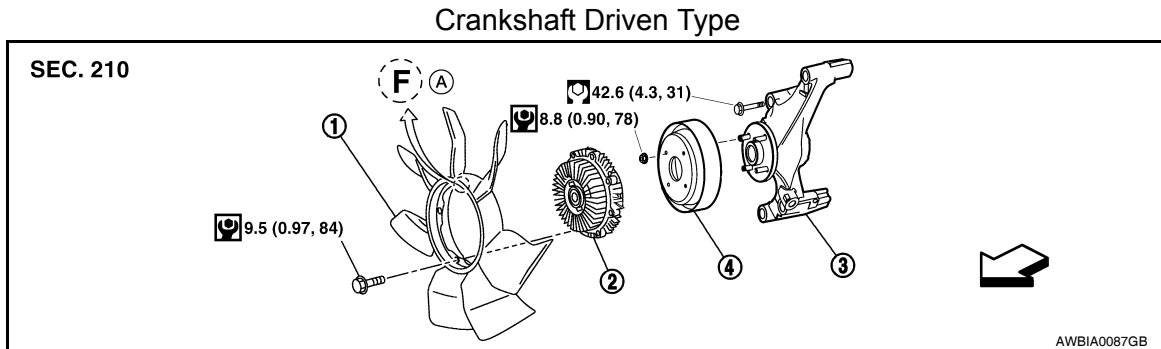

- | | | |
|-----------------------|-----------------|----------------|
| 1. Cooling fan | 2. Fan coupling | 3. Fan bracket |
| 4. Cooling fan pulley | A. Front mark | ← Front |

Removal and Installation (Crankshaft Driven Type)

INFOID:000000005260585

REMOVAL

1. Remove the engine front under cover. Refer to [EXT-14, "Removal and Installation"](#).
2. Partially drain engine coolant from radiator. Refer to [CO-11](#).
CAUTION:
 - Perform this step when engine is cold.
 - Do not spill engine coolant on drive belts.
3. Remove engine room cover. Refer to [EM-160, "Removal and Installation"](#).
4. Remove the air duct and resonator assembly. Refer to [EM-161, "Removal and Installation"](#).
5. Remove reservoir tank hose from radiator.
6. Remove reservoir tank hose from engine.
7. Removal radiator hose (upper).
CAUTION:
 - Do not spill engine coolant on drive belts.
8. Remove radiator hose (lower).
9. Remove A/T fluid cooler hose from radiator.
10. Remove the radiator shroud (lower) and position aside.
 - Release the tabs, pull radiator shroud (lower) rearwards and down to remove.

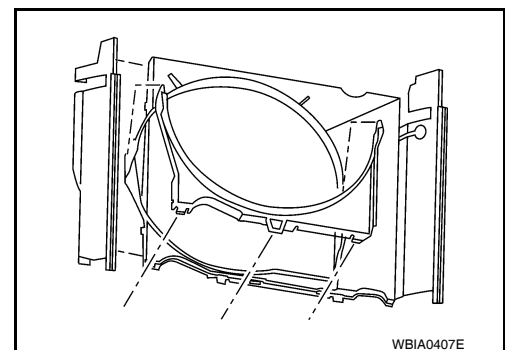

ENGINE COOLING FAN

< ON-VEHICLE REPAIR >

[VK56DE]

11. Remove the radiator shroud (upper) bolts and remove the radiator shroud (upper) (A).

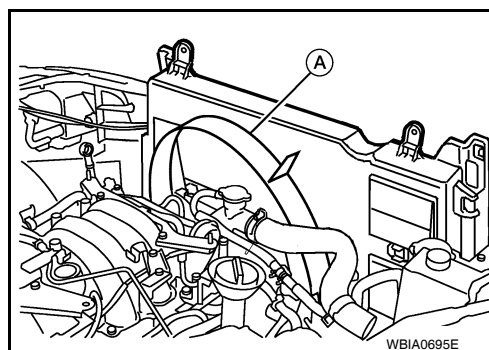

12. Remove the drive belt. Refer to [EM-149. "Removal and Installation"](#).
13. Remove the engine cooling fan.
14. Remove fan coupling, if necessary.
15. Remove cooling fan pulley, if necessary.
16. Remove fan bracket, if necessary.

INSPECTION AFTER REMOVAL

Fan Coupling

- Inspect fan coupling for oil leakage and bimetal conditions.
- If there are any unusual concerns, replace the fan coupling.

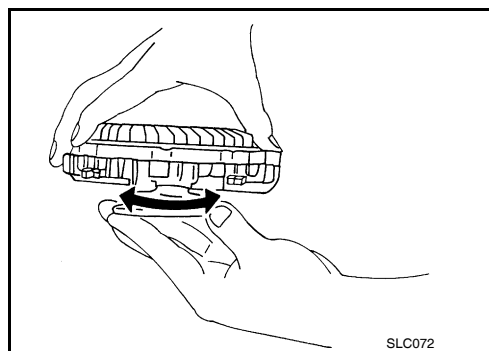

Fan Bracket

- Visually check that there is no significant looseness in the fan bracket shaft, and that it turns smoothly by hand.
- If there are any unusual concerns, replace the fan bracket assembly.

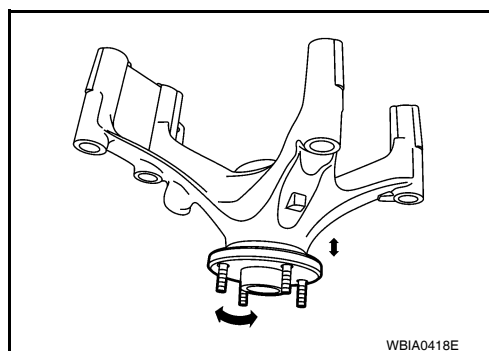

INSTALLATION

Installation is in the reverse order of removal.

- Install cooling fan with its front mark "F" facing front of engine. Refer to [CO-48. "Removal and Installation \(Crankshaft Driven Type\)"](#).

INSPECTION AFTER INSTALLATION

- Check for leaks of engine coolant. Refer to [CO-39. "System Inspection"](#).
- Start and warm up the engine. Visually make sure that there are no leaks of engine coolant.

Removal and Installation (Motor Driven Type)

INFOID:000000005260586

REMOVAL

1. Remove the front grille. Refer to [EXT-18. "Removal and Installation"](#).

A
CO
C
D
E
F
G
H
I
J
K
L
M
N
O
P

ENGINE COOLING FAN

[VK56DE]

< ON-VEHICLE REPAIR >

2. Loosen the lower fan motor nuts (A).

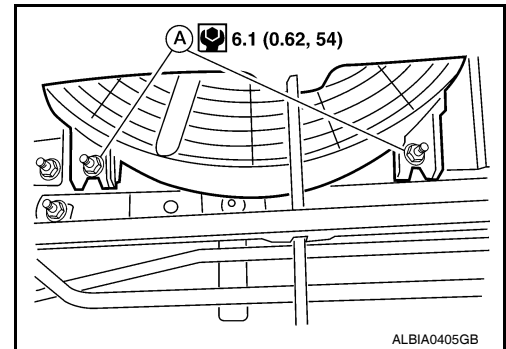

3. Disconnect harness connector (A) from fan motor.
4. Remove the upper fan motor bolts (B) and remove the fan grille and motor assembly.

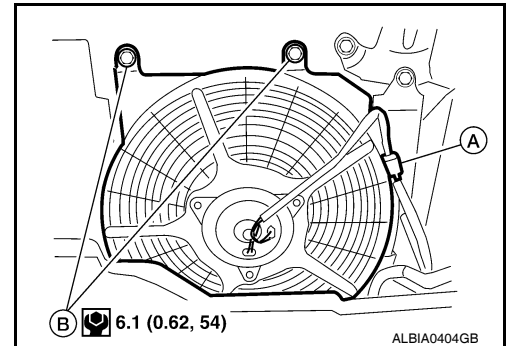

INSTALLATION

Installation is in the reverse order of removal.

- Cooling fan is controlled by ECM. For details, refer to [EC-530. "Description"](#).

WATER PUMP

< ON-VEHICLE REPAIR >

[VK56DE]

WATER PUMP

Exploded View

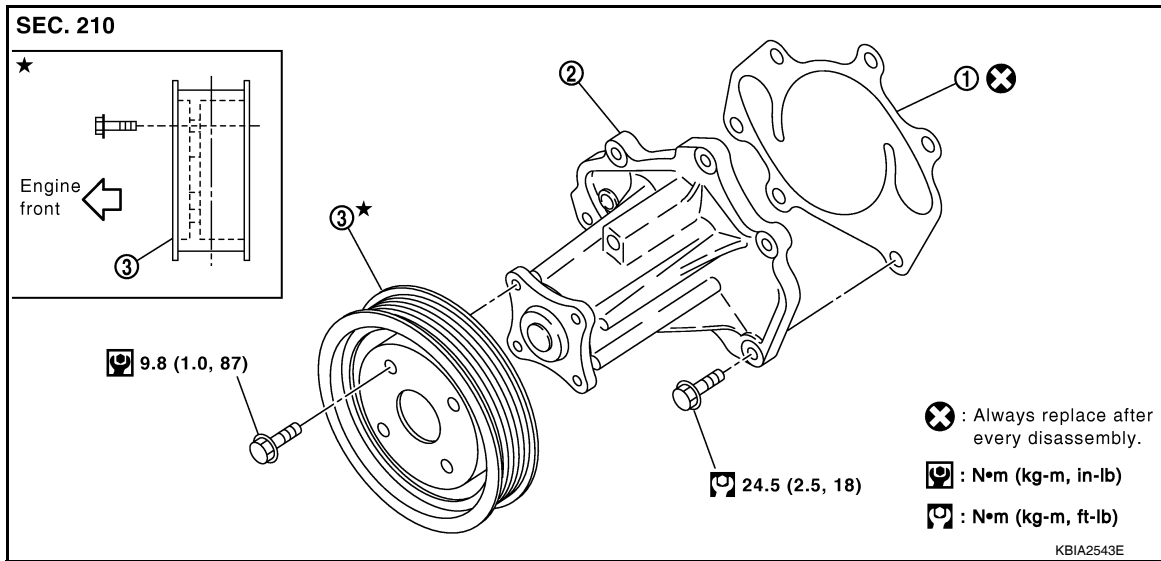

1. Gasket

2. Water pump

3. Water pump pulley

Removal and Installation

INFOID:000000005260588

CAUTION:

- When removing water pump, be careful not to get engine coolant on drive belt.
- Water pump cannot be disassembled and should be replaced as a unit.
- After installing water pump, connect hoses and clamps securely, then check for leaks.

REMOVAL

1. Remove engine front under cover. Refer to [EXT-14, "Removal and Installation"](#).
2. Drain engine coolant from the radiator. Refer to [CO-40, "Changing Engine Coolant"](#).
CAUTION:
 - Perform when the engine is cold.
 - Do not spill engine coolant on drive belt.
3. Remove the engine room cover. Refer to [EM-160, "Removal and Installation"](#).
4. Remove the air duct and resonator assembly. Refer to [EM-161, "Removal and Installation"](#).
5. Remove drive belt. Refer to [EM-149, "Removal and Installation"](#).
6. Remove reservoir tank hose from radiator shroud (upper).
7. Remove reservoir tank hose from engine.
8. Remove radiator hose (upper).
CAUTION:
Do not spill engine coolant on drive belt.
9. Remove the radiator hose (lower).
10. Remove the A/T fluid cooler hose from the radiator.
11. Remove the radiator shroud (lower) and position aside.
 - Release the tabs, pull radiator shroud (lower) rearwards and down to remove.

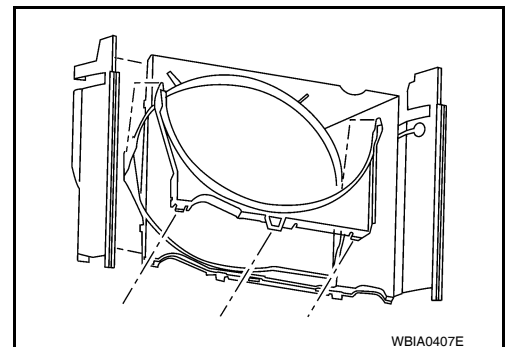

WATER PUMP

[VK56DE]

< ON-VEHICLE REPAIR >

12. Remove the radiator shroud (upper) bolts and remove the radiator shroud (upper) (A).

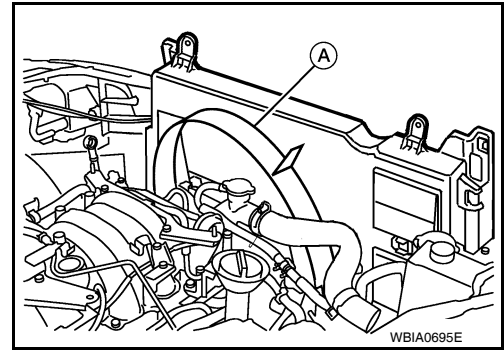

13. Remove the engine cooling fan (crankshaft driven type). Refer to [CO-48. "Removal and Installation \(Crankshaft Driven Type\)"](#).
14. Remove the water pump pulley.
15. Remove the water pump.
 - Engine coolant will leak from the cylinder block, so have a receptacle ready below.

CAUTION:

Handle water pump vane so that it does not contact any other parts.

INSPECTION AFTER REMOVAL

- Visually check that there is no significant dirt or rust on the water pump body and vane.
- Make sure there is no looseness in the vane shaft, and that it turns smoothly when rotated by hand.
- Replace the water pump, if necessary.

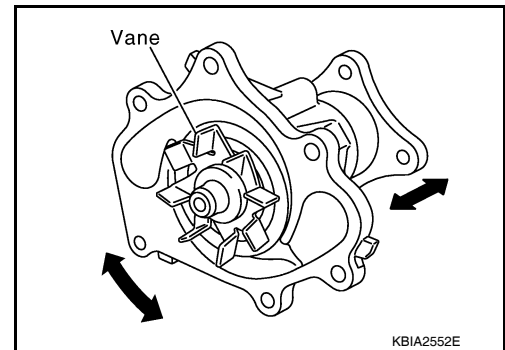

INSTALLATION

Installation is in the reverse order of removal.

- After installation bleed the air from the cooling system. Refer to [CO-40. "Changing Engine Coolant"](#).

INSPECTION AFTER INSTALLATION

- Check for leaks of engine coolant. Refer to [CO-39. "System Inspection"](#).
- Start and warm up engine. Visually check for leaks of engine coolant.

THERMOSTAT AND WATER PIPING

< ON-VEHICLE REPAIR >

[VK56DE]

THERMOSTAT AND WATER PIPING

Exploded View

INFOID:000000005260589

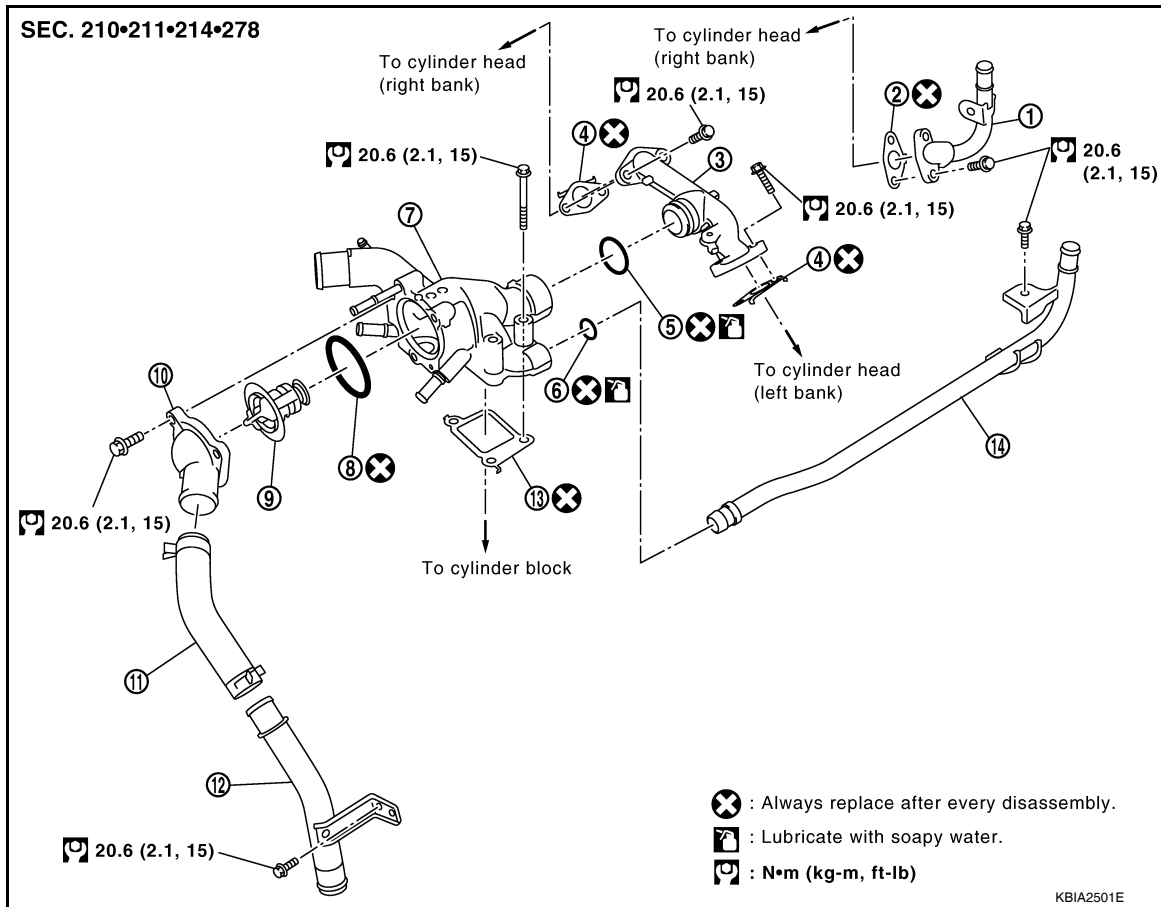

- | | | |
|-----------------------|------------------------|------------------------|
| 1. Heater pipe | 2. Gasket | 3. Water outlet |
| 4. Gasket | 5. O-ring | 6. O-ring |
| 7. Thermostat housing | 8. Rubber ring | 9. Thermostat |
| 10. Water inlet | 11. Water suction hose | 12. Water suction pipe |
| 13. Gasket | 14. Heater pipe | |

Removal and Installation

INFOID:000000005260590

REMOVAL

Removal of Thermostat

1. Remove engine under cover. Refer to [EXT-14, "Removal and Installation"](#).
2. Partially drain engine coolant from the radiator. Refer to [CO-40, "Changing Engine Coolant"](#).
CAUTION:
Perform when engine is cold.
3. Remove the engine room cover. Refer to [EM-160, "Removal and Installation"](#).
4. Remove the air duct and resonator assembly. Refer to [EM-161, "Removal and Installation"](#).
5. Disconnect the water suction hose from the water inlet.
6. Remove the water inlet and thermostat.

Removal of Thermostat Housing, Water Outlet and Heater Pipe

1. Remove the intake manifold. Refer to [EM-162, "Removal and Installation"](#).
2. Remove the thermostat housing, water outlet and heater pipe.

INSPECTION AFTER REMOVAL

THERMOSTAT AND WATER PIPING

[VK56DE]

< ON-VEHICLE REPAIR >

1. Check valve seating condition at ordinary room temperature. It should seat tightly.
2. Check valve operation.
 - Place a thread so that it is caught in the valve of the thermostat. Immerse fully in a container filled with water. Heat while stirring.
 - The valve opening temperature is the temperature at which the valve opens and falls from the thread.
 - Continue heating. Check the full-open lift amount.
 - After checking the full-open lift amount, lower the water temperature and check the valve closing temperature.

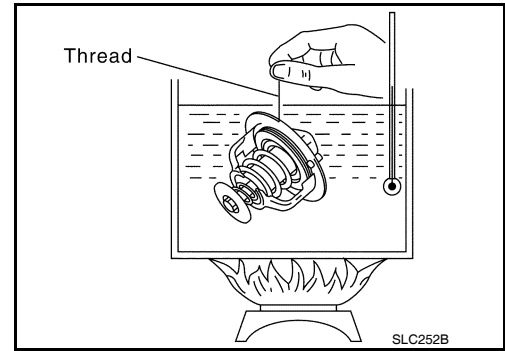

Thermostat	Standard
Valve opening temperature	80 - 84°C (176 - 183°F)
Full-open lift amount	More than 10 mm/ 95°C (0.39 in/ 203°F)
Valve closing temperature	77°C (171°F) or higher

- If valve seating at ordinary room temperature, or measured values are out of standard, replace the thermostat.

INSTALLATION

Installation is in the reverse order of removal.

CAUTION:

Do not spill engine coolant in engine room. Use a rag to absorb engine coolant.

Installation of Thermostat

- Install the thermostat with the whole circumference of each flange part fit securely inside the rubber ring as shown.
- Install the thermostat with the jiggle valve facing upwards.

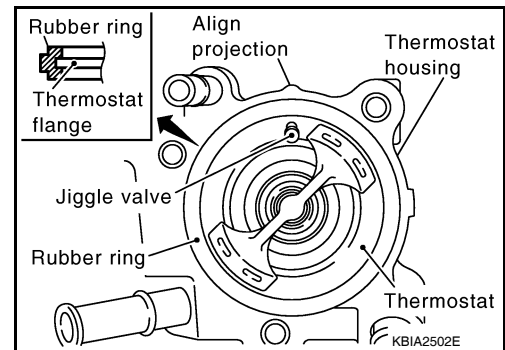

Installation of Water Outlet Pipe and Heater Pipe

First apply a neutral detergent to the O-rings, then quickly insert the insertion parts of the water outlet pipe and heater pipe into the installation holes.

INSPECTION AFTER INSTALLATION

- Check for leaks of engine coolant. Refer to [CO-39, "System Inspection"](#).
- Start and warm up the engine. Visually check for leaks of engine coolant.

SERVICE DATA AND SPECIFICATIONS (SDS)

< SERVICE DATA AND SPECIFICATIONS (SDS)

[VK56DE]

SERVICE DATA AND SPECIFICATIONS (SDS)

SERVICE DATA AND SPECIFICATIONS (SDS)

Standard and Limit

INFOID:000000005260591

A

CO

ENGINE COOLANT CAPACITY (APPROXIMATE)

Unit: ℓ (US qt, Imp qt)

Engine coolant capacity (With reservoir tank at "MAX" level)	13.4 (14-1/8, 11-3/4)
--	-----------------------

C

RADIATOR

Unit: kPa (kg/cm², psi)

Reservoir cap relief pressure	Standard	98 - 118 (1.0- 1.2, 14 - 17)
Leakage test pressure		137 (1.4, 20)

D

E

THERMOSTAT

Valve opening temperature	80 - 84°C (176 - 183°F)
Full-open lift amount	More than 10 mm/95°C (0.39 in/203°F)
Valve closing temperature	77°C (171°F) or higher

F

G

H

I

J

K

L

M

N

O

P