

SECTION **EXT**
EXTERIOR

A
B
C
D
E
F
G
H
I
J
EXT
L
M
N
O
P

CONTENTS

PRECAUTION	2	Removal and Installation	18
PRECAUTIONS	2	FRONT GRILLE	20
Precaution for Supplemental Restraint System (SRS) "AIR BAG" and "SEAT BELT PRE-TENSIONER"	2	Removal and Installation	20
Precaution Necessary for Steering Wheel Rotation After Battery Disconnect	2	COWL TOP	21
Service Notice	3	Removal and Installation	21
Precaution for Procedure without Cowl Top Cover.....	3	FRONT FENDER	22
Precaution for Work	3	Removal and Installation	22
PREPARATION	4	LICENSE LAMP FINISHER	23
PREPARATION	4	Removal and Installation	23
Special Service Tool	4	FENDER PROTECTOR	24
Commercial Service Tool	4	Component	24
CLIP LIST	5	Removal and Installation of Front Fender Protector	25
Descriptions for Clips	5	Removal and Installation of Rear Fender Protector	25
PERIODIC MAINTENANCE	9	MUDGUARD	26
SQUEAK AND RATTLE TROUBLE DIAGNOSES	9	Removal and Installation	26
Work Flow	9	RUNNING BOARDS	27
Generic Squeak and Rattle Troubleshooting	11	Removal and Installation	27
Diagnostic Worksheet	13	ROOF RACK	28
REMOVAL AND INSTALLATION	15	Removal and Installation	28
FRONT BUMPER	15	DOOR OUTSIDE MOLDING	29
Removal and Installation	15	Removal and Installation	29
REAR BUMPER	18	SIDE GUARD MOLDING	30
		Removal and Installation	30

PRECAUTIONS

< PRECAUTION >

PRECAUTION

PRECAUTIONS

Precaution for Supplemental Restraint System (SRS) "AIR BAG" and "SEAT BELT PRE-TENSIONER"

INFOID:000000006245321

The Supplemental Restraint System such as "AIR BAG" and "SEAT BELT PRE-TENSIONER", used along with a front seat belt, helps to reduce the risk or severity of injury to the driver and front passenger for certain types of collision. This system includes seat belt switch inputs and dual stage front air bag modules. The SRS system uses the seat belt switches to determine the front air bag deployment, and may only deploy one front air bag, depending on the severity of a collision and whether the front occupants are belted or unbelted. Information necessary to service the system safely is included in the SR and SB section of this Service Manual.

WARNING:

- To avoid rendering the SRS inoperative, which could increase the risk of personal injury or death in the event of a collision which would result in air bag inflation, all maintenance must be performed by an authorized NISSAN/INFINITI dealer.
- Improper maintenance, including incorrect removal and installation of the SRS, can lead to personal injury caused by unintentional activation of the system. For removal of Spiral Cable and Air Bag Module, see the SR section.
- Do not use electrical test equipment on any circuit related to the SRS unless instructed to in this Service Manual. SRS wiring harnesses can be identified by yellow and/or orange harnesses or harness connectors.

PRECAUTIONS WHEN USING POWER TOOLS (AIR OR ELECTRIC) AND HAMMERS

WARNING:

- When working near the Airbag Diagnosis Sensor Unit or other Airbag System sensors with the Ignition ON or engine running, DO NOT use air or electric power tools or strike near the sensor(s) with a hammer. Heavy vibration could activate the sensor(s) and deploy the air bag(s), possibly causing serious injury.
- When using air or electric power tools or hammers, always switch the Ignition OFF, disconnect the battery, and wait at least 3 minutes before performing any service.

Precaution Necessary for Steering Wheel Rotation After Battery Disconnect

INFOID:000000006245322

NOTE:

- This Procedure is applied only to models with Intelligent Key system and NATS (NISSAN ANTI-THEFT SYSTEM).
- Remove and install all control units after disconnecting both battery cables with the ignition knob in the "LOCK" position.
- Always use CONSULT-III to perform self-diagnosis as a part of each function inspection after finishing work. If DTC is detected, perform trouble diagnosis according to self-diagnostic results.

For models equipped with the Intelligent Key system and NATS, an electrically controlled steering lock mechanism is adopted on the key cylinder.

For this reason, if the battery is disconnected or if the battery is discharged, the steering wheel will lock and steering wheel rotation will become impossible.

If steering wheel rotation is required when battery power is interrupted, follow the procedure below before starting the repair operation.

OPERATION PROCEDURE

1. Connect both battery cables.

NOTE:

Supply power using jumper cables if battery is discharged.

2. Use the Intelligent Key or mechanical key to turn the ignition switch to the "ACC" position. At this time, the steering lock will be released.
3. Disconnect both battery cables. The steering lock will remain released and the steering wheel can be rotated.
4. Perform the necessary repair operation.

PRECAUTIONS

< PRECAUTION >

5. When the repair work is completed, return the ignition switch to the "LOCK" position before connecting the battery cables. (At this time, the steering lock mechanism will engage.)
6. Perform a self-diagnosis check of all control units using CONSULT-III.

Service Notice

INFOID:000000006245323

- When removing or installing various parts, place a cloth or padding on the vehicle body to prevent scratches.
- Handle trim, molding, instruments, grille, etc. carefully during removing or installing. Be careful not to soil or damage them.
- Apply sealing compound where necessary when installing parts.
- When applying sealing compound, be careful that the sealing compound does not protrude from parts.
- When replacing any metal parts (for example body outer panel, members, etc.), be sure to take rust prevention measures.

Precaution for Procedure without Cowl Top Cover

INFOID:000000006245324

When performing the procedure after removing cowl top cover, cover the lower end of windshield with urethane, etc.

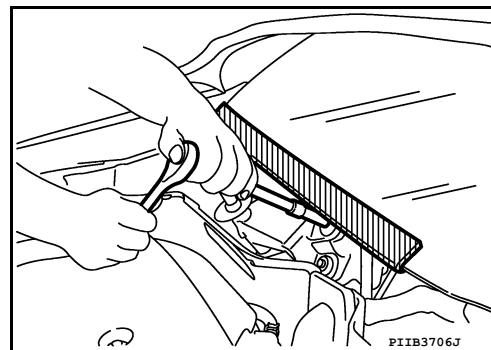

Precaution for Work

INFOID:000000006826811

- When removing or disassembling each component, be careful not to damage or deform it. If a component may be subject to interference, be sure to protect it with a shop cloth.
- When removing (disengaging) components with a screwdriver or similar tool, be sure to wrap the component with a shop cloth or vinyl tape to protect it.
- Protect the removed parts with a shop cloth and prevent them from being dropped.
- Replace a deformed or damaged clip.
- If a part is specified as a non-reusable part, always replace it with new one.
- Be sure to tighten bolts and nuts securely to the specified torque.
- After installation is complete, be sure to check that each part works properly.
- Follow the steps below to clean components.
 - Water soluble dirt: Dip a soft cloth into lukewarm water, and wring the water out of the cloth to wipe the dirty area.
Then rub with a soft and dry cloth.
 - Oily dirt: Dip a soft cloth into lukewarm water with mild detergent (concentration: within 2 to 3%), and wipe the dirty area.
Then dip a cloth into fresh water, and wring the water out of the cloth to wipe the detergent off. Then rub with a soft and dry cloth.
- Do not use organic solvent such as thinner, benzene, alcohol, or gasoline.
- For genuine leather seats, use a genuine leather seat cleaner.

CLIP LIST







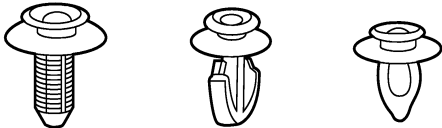

< PREPARATION >

CLIP LIST

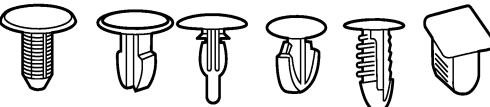
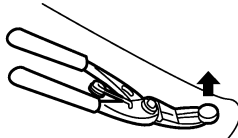
Descriptions for Clips

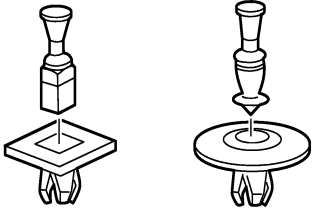
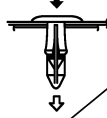
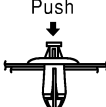
INFOID:000000008189290

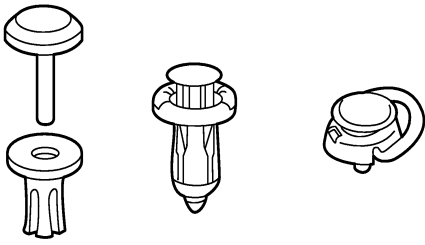
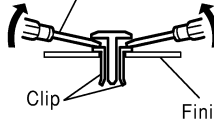
Replace any clips which are damaged during removal or installation.

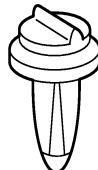
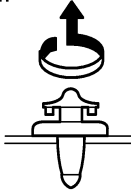





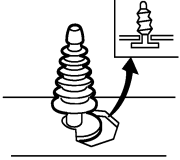
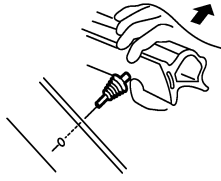

Symbol No.	Shapes	Removal & Installation
C101 		Removal: Remove by bending up with flat-bladed screwdrivers or clip remover. 
C103 		Removal: Remove with a clip remover. 
C203 		Removal: Push center pin to catching position. (Do not remove center pin by hitting it.) Push  Installation: Push 
C205 		Removal: Flat-bladed screwdriver Clip Finisher 
C206 		Removal: 

SIIA0315E

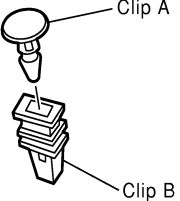
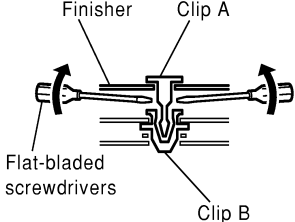
A
B
C
D
E
F
G
H
I
J
EXT
L
M
N
O
P

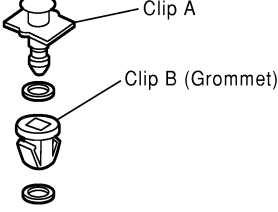
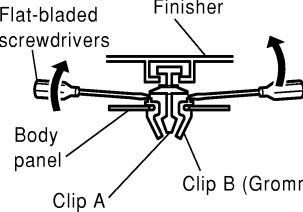
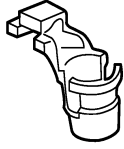
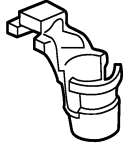
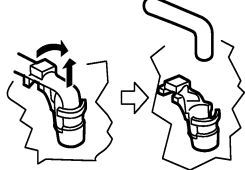
CLIP LIST

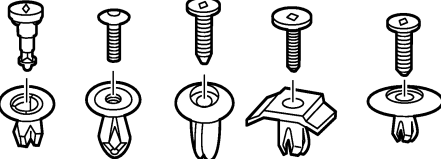







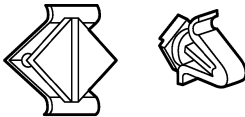

< PREPARATION >

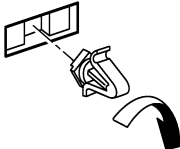
Symbol No.	Shapes	Removal & Installation
<p>CE103</p> 		<p>Removal:</p> 
<p>CF110</p> 		<p>Removal:</p> 
<p>CF118</p> 		<p>Removal:</p> 
<p>CR103</p> 		<p>Removal: Holder portion of clip must be spread out to remove rod.</p> 
<p>CS101</p> 		<p>Removal:</p> <ol style="list-style-type: none"> 1. Screw out with a Phillips screwdriver. 2. Remove female portion with flat-bladed screwdriver. 

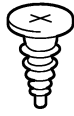
SIIA0316E

CLIP LIST

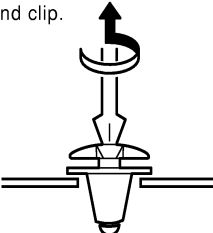
< PREPARATION >

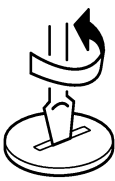



Symbol No.	Shapes	Removal & Installation	
CG101 		Removal:  Rotate 45° to remove	Installation: 
CS102 			
CS113 		Removal: Disconnect upper connection of clip with a flat-bladed screwdriver, then remove clip while inserting a flat-bladed screwdriver between body panel and clip. 	
C111 			

S1IA0317E

A
B
C
D
E
F
G
H
I
J
EXT
L
M
N
O
P

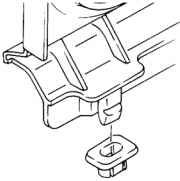
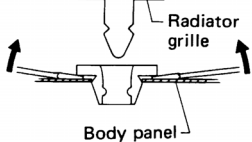
CLIP LIST

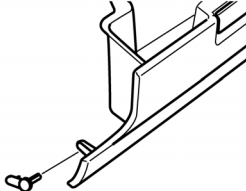
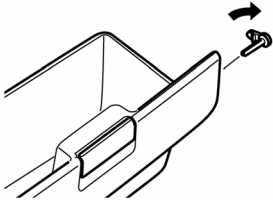
< PREPARATION >

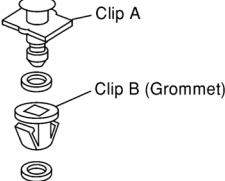
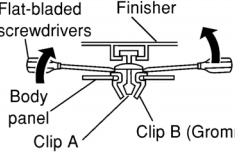
Symbol No.	Shapes	Removal & Installation
<p>CG104</p> 		<p>Removal: Remove by bending up with flat-bladed screwdrivers.</p>  <p>Radiator grille Body panel</p>
<p>CE114</p> 		
<p>CF118</p> 	 <p>Clip A Clip B (Grommet)</p>	<p>Removal: Flat-bladed screwdrivers Finisher</p>  <p>Body panel Clip A Clip B (Grommet)</p>

ALJIA0564GB

SQUEAK AND RATTLE TROUBLE DIAGNOSES

< PERIODIC MAINTENANCE >

PERIODIC MAINTENANCE

SQUEAK AND RATTLE TROUBLE DIAGNOSES

Work Flow

INFOID:000000006826825

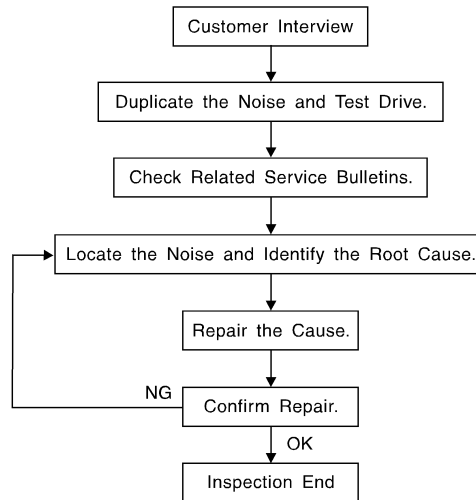

SBT842

CUSTOMER INTERVIEW

Interview the customer if possible, to determine the conditions that exist when the noise occurs. Use the Diagnostic Worksheet during the interview to document the facts and conditions when the noise occurs and any customer's comments; refer to [EXT-13, "Diagnostic Worksheet"](#). This information is necessary to duplicate the conditions that exist when the noise occurs.

- The customer may not be able to provide a detailed description or the location of the noise. Attempt to obtain all the facts and conditions that exist when the noise occurs (or does not occur).
- If there is more than one noise in the vehicle, be sure to diagnose and repair the noise that the customer is concerned about. This can be accomplished by test driving the vehicle with the customer.
- After identifying the type of noise, isolate the noise in terms of its characteristics. The noise characteristics are provided so the customer, service adviser and technician are all speaking the same language when defining the noise.
- Squeak —(Like tennis shoes on a clean floor)
Squeak characteristics include the light contact/fast movement/brought on by road conditions/hard surfaces = higher pitch noise/softer surfaces = lower pitch noises/edge to surface = chirping.
- Creak—(Like walking on an old wooden floor)
Creak characteristics include firm contact/slow movement/twisting with a rotational movement/pitch dependent on materials/often brought on by activity.
- Rattle—(Like shaking a baby rattle)
Rattle characteristics include the fast repeated contact/vibration or similar movement/loose parts/missing clip or fastener/incorrect clearance.
- Knock —(Like a knock on a door)
Knock characteristics include hollow sounding/sometimes repeating/often brought on by driver action.
- Tick—(Like a clock second hand)
Tick characteristics include gentle contacting of light materials/loose components/can be caused by driver action or road conditions.
- Thump—(Heavy, muffled knock noise)
Thump characteristics include softer knock/dead sound often brought on by activity.
- Buzz—(Like a bumble bee)
Buzz characteristics include high frequency rattle/firm contact.
- Often the degree of acceptable noise level will vary depending upon the person. A noise that you may judge as acceptable may be very irritating to the customer.
- Weather conditions, especially humidity and temperature, may have a great effect on noise level.

DUPLICATE THE NOISE AND TEST DRIVE

SQUEAK AND RATTLE TROUBLE DIAGNOSES

< PERIODIC MAINTENANCE >

If possible, drive the vehicle with the customer until the noise is duplicated. Note any additional information on the Diagnostic Worksheet regarding the conditions or location of the noise. This information can be used to duplicate the same conditions when you confirm the repair.

If the noise can be duplicated easily during the test drive, to help identify the source of the noise, try to duplicate the noise with the vehicle stopped by doing one or all of the following:

- 1) Close a door.
 - 2) Tap or push/pull around the area where the noise appears to be coming from.
 - 3) Rev the engine.
 - 4) Use a floor jack to recreate vehicle "twist".
 - 5) At idle, apply engine load (electrical load, half-clutch on M/T model, drive position on CVT and A/T models).
 - 6) Raise the vehicle on a hoist and hit a tire with a rubber hammer.
- Drive the vehicle and attempt to duplicate the conditions the customer states exist when the noise occurs.
 - If it is difficult to duplicate the noise, drive the vehicle slowly on an undulating or rough road to stress the vehicle body.

CHECK RELATED SERVICE BULLETINS

After verifying the customer concern or symptom, check ASIST for Technical Service Bulletins (TSBs) related to that concern or symptom.

If a TSB relates to the symptom, follow the procedure to repair the noise.

LOCATE THE NOISE AND IDENTIFY THE ROOT CAUSE

1. Narrow down the noise to a general area. To help pinpoint the source of the noise, use a listening tool (Chassis Ear: J-39570, Engine Ear: J-39565 and mechanic's stethoscope).
2. Narrow down the noise to a more specific area and identify the cause of the noise by:
 - removing the components in the area that you suspect the noise is coming from.
Do not use too much force when removing clips and fasteners, otherwise clips and fasteners can be broken or lost during the repair, resulting in the creation of new noise.
 - tapping or pushing/pulling the component that you suspect is causing the noise.
Do not tap or push/pull the component with excessive force, otherwise the noise will be eliminated only temporarily.
 - feeling for a vibration with your hand by touching the component(s) that you suspect is (are) causing the noise.
 - placing a piece of paper between components that you suspect are causing the noise.
 - looking for loose components and contact marks.
Refer to [EXT-11, "Generic Squeak and Rattle Troubleshooting"](#).

REPAIR THE CAUSE

- If the cause is a loose component, tighten the component securely.
- If the cause is insufficient clearance between components:
 - separate components by repositioning or loosening and retightening the component, if possible.
 - insulate components with a suitable insulator such as urethane pads, foam blocks, felt cloth tape or urethane tape. A NISSAN Squeak and Rattle Kit (J-43980) is available through your authorized NISSAN Parts Department.

CAUTION:

Do not use excessive force as many components are constructed of plastic and may be damaged.

Always check with the Parts Department for the latest parts information.

The following materials are contained in the NISSAN Squeak and Rattle Kit (J-43980). Each item can be ordered separately as needed.

URETHANE PADS [1.5 mm (0.059 in) thick]

Insulates connectors, harness, etc.

76268-9E005: 100×135 mm (3.94×5.31 in)/76884-71L01: 60×85 mm (2.36×3.35 in)/76884-71L02: 15×25 mm (0.59×0.98 in)

INSULATOR (Foam blocks)

Insulates components from contact. Can be used to fill space behind a panel.

73982-9E000: 45 mm (1.77 in) thick, 50×50 mm (1.97×1.97 in)/73982-50Y00: 10 mm (0.39 in) thick, 50×50 mm (1.97×1.97 in)

INSULATOR (Light foam block)

80845-71L00: 30 mm (1.18 in) thick, 30×50 mm (1.18×1.97 in)

FELT CLOTH TAPE

Used to insulate where movement does not occur. Ideal for instrument panel applications.

68370-4B000: 15×25 mm (0.59×0.98 in) pad/68239-13E00: 5 mm (0.20 in) wide tape roll. The following materials not found in the kit can also be used to repair squeaks and rattles.

SQUEAK AND RATTLE TROUBLE DIAGNOSES

< PERIODIC MAINTENANCE >

UHMW (TEFLON) TAPE

Insulates where slight movement is present. Ideal for instrument panel applications.

SILICONE GREASE

Used instead of UHMW tape that will be visible or not fit.

Note: Will only last a few months.

SILICONE SPRAY

Use when grease cannot be applied.

DUCT TAPE

Use to eliminate movement.

CONFIRM THE REPAIR

Confirm that the cause of a noise is repaired by test driving the vehicle. Operate the vehicle under the same conditions as when the noise originally occurred. Refer to the notes on the Diagnostic Worksheet.

Generic Squeak and Rattle Troubleshooting

INFOID:000000006826826

Refer to Table of Contents for specific component removal and installation information.

INSTRUMENT PANEL

Most incidents are caused by contact and movement between:

1. Cluster lid A and the instrument panel
2. Acrylic lens and combination meter housing
3. Instrument panel to front pillar finisher
4. Instrument panel to windshield
5. Instrument panel pins
6. Wiring harnesses behind the combination meter
7. A/C defroster duct and duct joint

These incidents can usually be located by tapping or moving the components to duplicate the noise or by pressing on the components while driving to stop the noise. Most of these incidents can be repaired by applying felt cloth tape or silicone spray (in hard to reach areas). Urethane pads can be used to insulate wiring harness.

CAUTION:

Do not use silicone spray to isolate a squeak or rattle. If you saturate the area with silicone, you will not be able to recheck the repair.

CENTER CONSOLE

Components to pay attention to include:

1. Shift selector assembly cover to finisher
2. A/C control unit and cluster lid C
3. Wiring harnesses behind audio and A/C control unit

The instrument panel repair and isolation procedures also apply to the center console.

DOORS

Pay attention to the:

1. Finisher and inner panel making a slapping noise
2. Inside handle escutcheon to door finisher
3. Wiring harnesses tapping
4. Door striker out of alignment causing a popping noise on starts and stops

Tapping or moving the components or pressing on them while driving to duplicate the conditions can isolate many of these incidents. You can usually insulate the areas with felt cloth tape or insulator foam blocks from the NISSAN Squeak and Rattle Kit (J-43980) to repair the noise.

TRUNK

Trunk noises are often caused by a loose jack or loose items put into the trunk by the owner.

In addition look for:

1. Trunk lid bumpers out of adjustment
2. Trunk lid striker out of adjustment
3. The trunk lid torsion bars knocking together

SQUEAK AND RATTLE TROUBLE DIAGNOSES

< PERIODIC MAINTENANCE >

4. A loose license plate or bracket

Most of these incidents can be repaired by adjusting, securing or insulating the item(s) or component(s) causing the noise.

SUNROOF/HEADLINING

Noises in the sunroof/headlining area can often be traced to one of the following:

1. Sunroof lid, rail, linkage or seals making a rattle or light knocking noise
2. Sun visor shaft shaking in the holder
3. Front or rear windshield touching headliner and squeaking

Again, pressing on the components to stop the noise while duplicating the conditions can isolate most of these incidents. Repairs usually consist of insulating with felt cloth tape.

OVERHEAD CONSOLE (FRONT AND REAR)

Overhead console noises are often caused by the console panel clips not being engaged correctly. Most of these incidents are repaired by pushing up on the console at the clip locations until the clips engage.

In addition look for:

1. Loose harness or harness connectors.
2. Front console map/reading lamp lens loose.
3. Loose screws at console attachment points.

SEATS

When isolating seat noise it's important to note the position the seat is in and the load placed on the seat when the noise is present. These conditions should be duplicated when verifying and isolating the cause of the noise.

Cause of seat noise include:

1. Headrest rods and holder
2. A squeak between the seat pad cushion and frame
3. The rear seatback lock and bracket

These noises can be isolated by moving or pressing on the suspected components while duplicating the conditions under which the noise occurs. Most of these incidents can be repaired by repositioning the component or applying urethane tape to the contact area.

UNDERHOOD

Some interior noise may be caused by components under the hood or on the engine wall. The noise is then transmitted into the passenger compartment.

Causes of transmitted underhood noise include:

1. Any component installed to the engine wall
2. Components that pass through the engine wall
3. Engine wall mounts and connectors
4. Loose radiator installation pins
5. Hood bumpers out of adjustment
6. Hood striker out of adjustment

These noises can be difficult to isolate since they cannot be reached from the interior of the vehicle. The best method is to secure, move or insulate one component at a time and test drive the vehicle. Also, engine rpm or load can be changed to isolate the noise. Repairs can usually be made by moving, adjusting, securing, or insulating the component causing the noise.

SQUEAK AND RATTLE TROUBLE DIAGNOSES

< PERIODIC MAINTENANCE >

Diagnostic Worksheet

INFOID:000000006826827

Dear Customer:

We are concerned about your satisfaction with your vehicle. Repairing a squeak or rattle sometimes can be very difficult. To help us fix your vehicle right the first time, please take a moment to note the area of the vehicle where the squeak or rattle occurs and under what conditions. You may be asked to take a test drive with a service advisor or technician to ensure we confirm the noise you are hearing.

SQUEAK & RATTLE DIAGNOSTIC WORKSHEET

I. WHERE DOES THE NOISE COME FROM? (circle the area of the vehicle)

The illustrations are for reference only, and may not reflect the actual configuration of your vehicle.

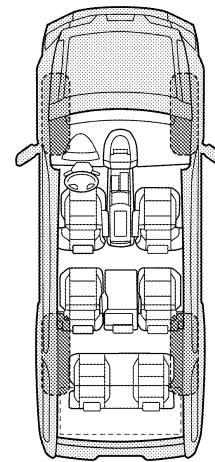
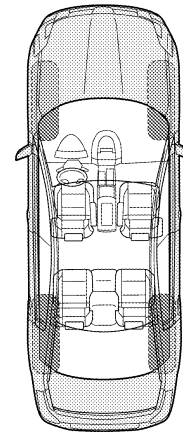
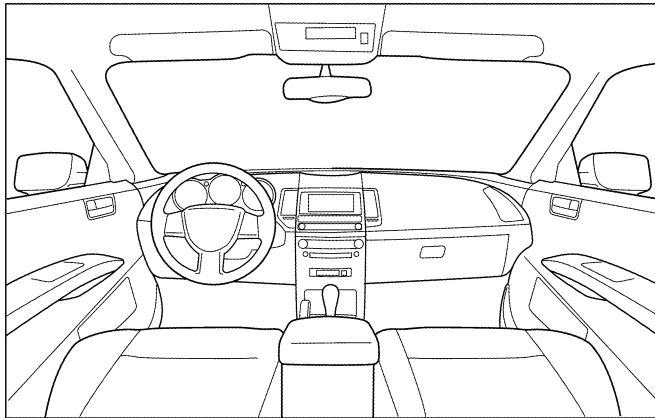

Continue to page 2 of the worksheet and briefly describe the location of the noise or rattle. In addition, please indicate the conditions which are present when the noise occurs.

A
B
C
D
E
F
G
H
I
J
EXT
L
M
N
O
P

SQUEAK AND RATTLE TROUBLE DIAGNOSES

< PERIODIC MAINTENANCE >

SQUEAK & RATTLE DIAGNOSTIC WORKSHEET - page 2

Briefly describe the location where the noise occurs:

II. WHEN DOES IT OCCUR? (please check the boxes that apply)

- | | |
|---|--|
| <input type="checkbox"/> Anytime | <input type="checkbox"/> After sitting out in the rain |
| <input type="checkbox"/> 1st time in the morning | <input type="checkbox"/> When it is raining or wet |
| <input type="checkbox"/> Only when it is cold outside | <input type="checkbox"/> Dry or dusty conditions |
| <input type="checkbox"/> Only when it is hot outside | <input type="checkbox"/> Other: |

III. WHEN DRIVING:

- Through driveways
- Over rough roads
- Over speed bumps
- Only about ____ mph
- On acceleration
- Coming to a stop
- On turns: left, right or either (circle)
- With passengers or cargo
- Other: _____
- After driving ____ miles or ____ minutes

IV. WHAT TYPE OF NOISE

- Squeak (like tennis shoes on a clean floor)
- Creak (like walking on an old wooden floor)
- Rattle (like shaking a baby rattle)
- Knock (like a knock at the door)
- Tick (like a clock second hand)
- Thump (heavy muffled knock noise)
- Buzz (like a bumble bee)

TO BE COMPLETED BY DEALERSHIP PERSONNEL

Test Drive Notes:

	YES	NO	Initials of person performing
Vehicle test driven with customer	<input type="checkbox"/>	<input type="checkbox"/>	_____
- Noise verified on test drive	<input type="checkbox"/>	<input type="checkbox"/>	_____
- Noise source located and repaired	<input type="checkbox"/>	<input type="checkbox"/>	_____
- Follow up test drive performed to confirm repair	<input type="checkbox"/>	<input type="checkbox"/>	_____

VIN: _____ Customer Name _____

W.O.# _____ Date: _____

This form must be attached to Work Order

LATA0071E

FRONT BUMPER

< REMOVAL AND INSTALLATION >

REMOVAL AND INSTALLATION

FRONT BUMPER

Removal and Installation

INFOID:000000006245331

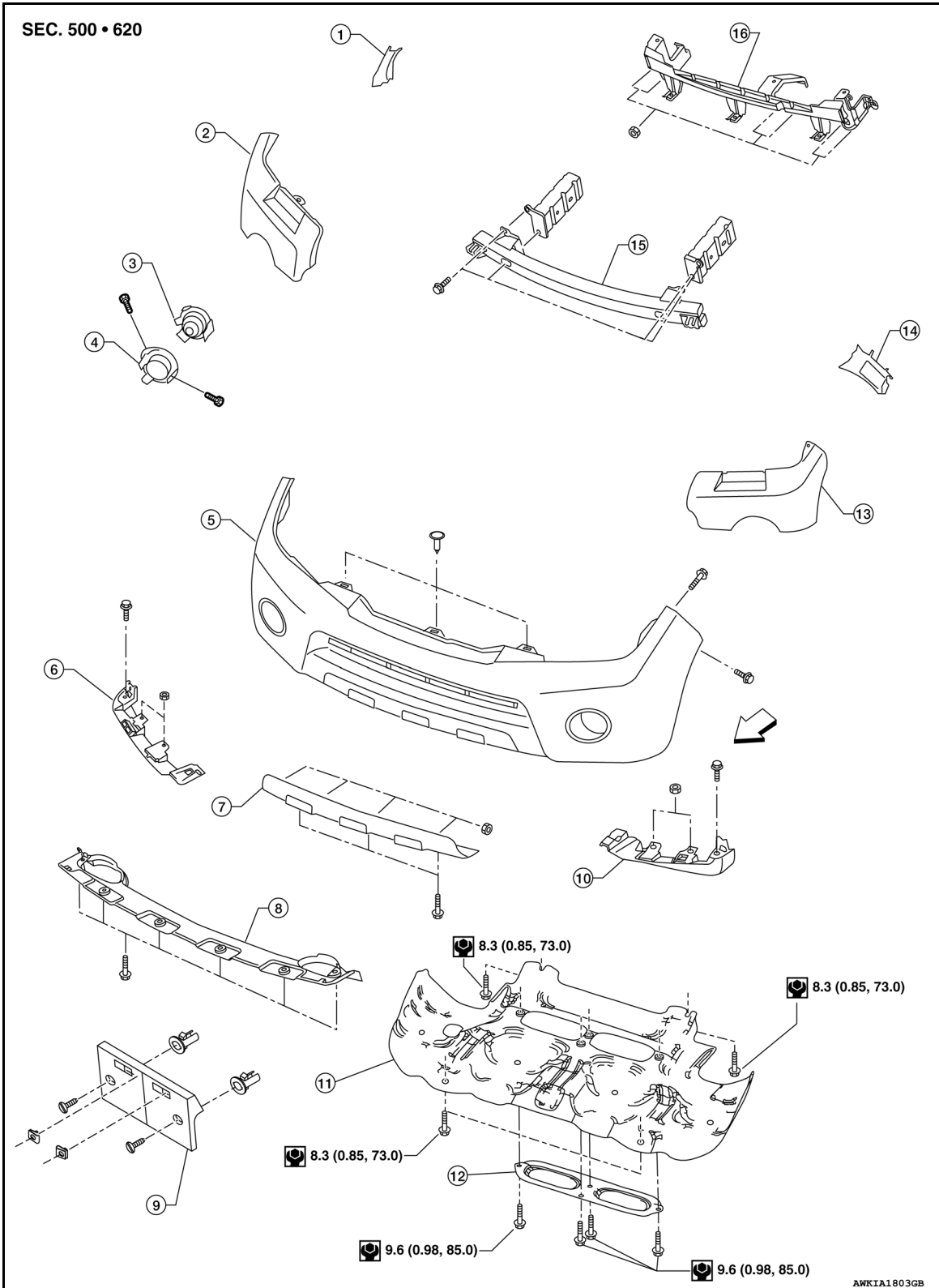

A

B

C

D

E

F

G

H

I

J

EXT

L

M

N

O

P

FRONT BUMPER

< REMOVAL AND INSTALLATION >

- | | | |
|--|----------------------------------|--|
| 1. Front bumper stay RH | 2. Front bumper reinforcement RH | 3. Fog lamp opening finisher (if equipped) |
| 4. Fog lamp (if equipped) | 5. Front bumper fascia assembly | 6. Front valance RH |
| 7. Front bumper protector assembly (if equipped) | 8. Front valance center | 9. Front license plate bracket |
| 10. Front valance LH | 11. Engine under cover | 12. Access cover |
| 13. Front bumper reinforcement LH | 14. Front bumper stay LH | 15. Front bumper |
| 16. Front bumper bracket | ↶ Vehicle front | |

REMOVAL

1. Remove the front grille. Refer to [EXT-20](#).
2. Remove the front fender protectors LH and RH. Refer to [EXT-25. "Removal and Installation of Front Fender Protector"](#).
3. Remove the front valance LH, center, then RH.
4. Disconnect the fog lamp harness connectors (if equipped).
5. Remove the front bumper fascia assembly.
6. Remove the front bumper.
7. Remove the front bumper bracket.

INSTALLATION

Installation is in the reverse order of removal.

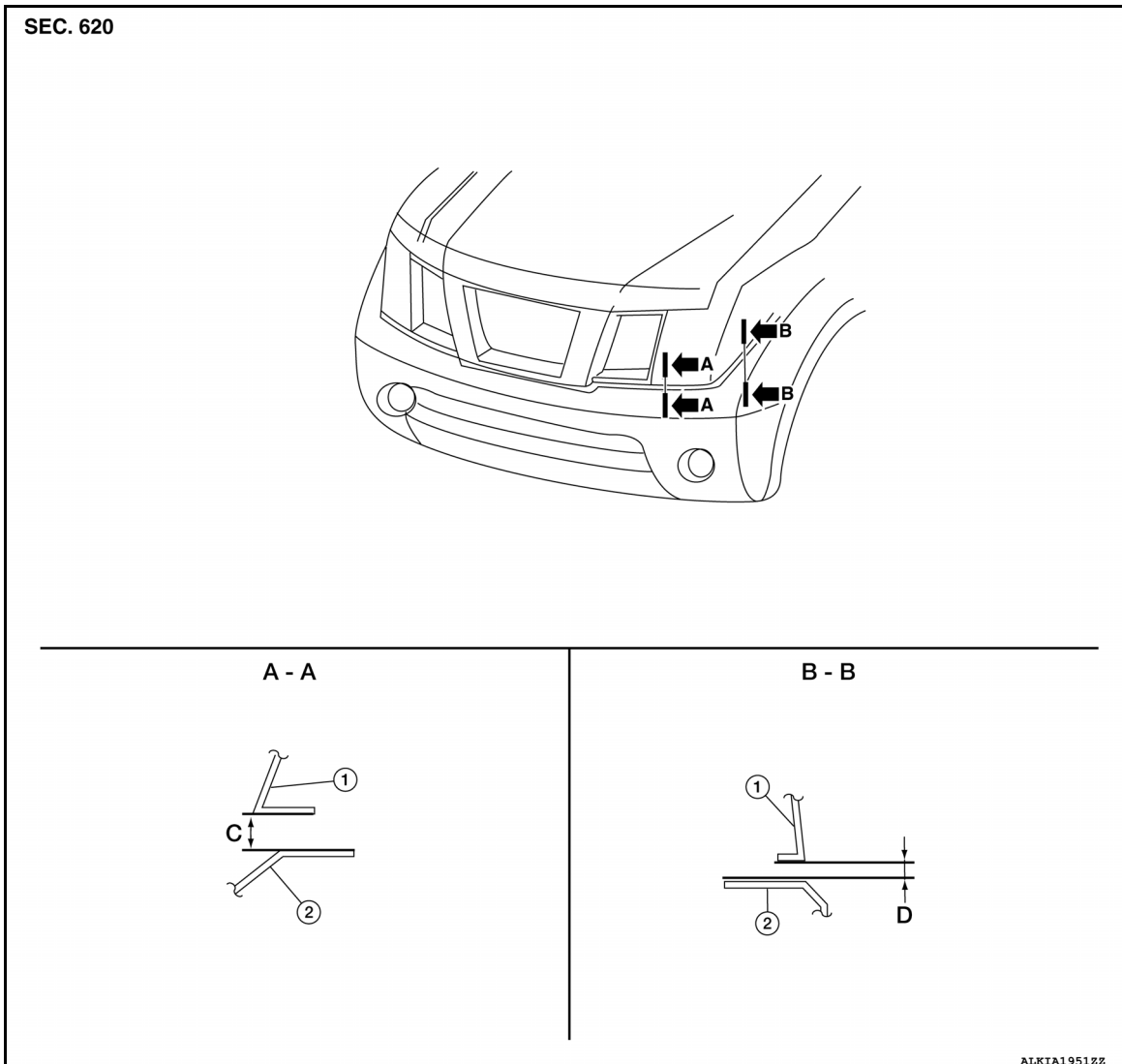

FRONT BUMPER

< REMOVAL AND INSTALLATION >

1. Headlamp assembly

2. Front bumper fascia

A

Units: mm (in)

Portion	Measurement		Standard	Difference (MAX)
A-A	C	Clearance	3.0 (0.118)	± 1.5 (0.059)
B-B	D	Clearance	3.0 (0.118)	± 1.5 (0.059)

B

C

D

E

F

G

H

I

J

EXT

L

M

N

O

P

REAR BUMPER

< REMOVAL AND INSTALLATION >

REAR BUMPER

Removal and Installation

INFOID:00000006245332

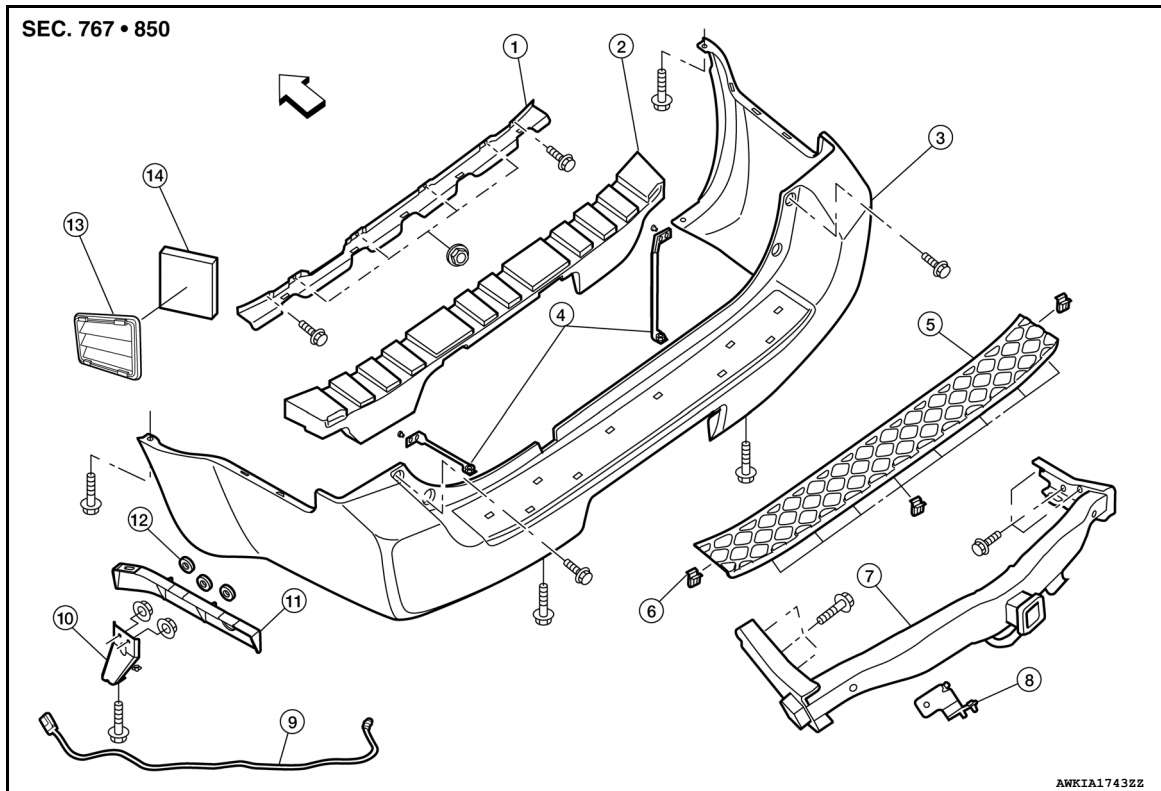

- | | | |
|---------------------------------------|------------------------------|-----------------------|
| 1. Rear valance | 2. Rear bumper reinforcement | 3. Rear bumper fascia |
| 4. Rear fascia strut LH/RH | 5. Step pad | 6. Clip |
| 7. Tow hitch | 8. Tow harness bracket | 9. Tow hitch harness |
| 10. Rear fascia lower stay (LH shown) | 11. Pinch rail | 12. Washer |
| 13. Drafter duct | 14. Filter element | ↵ Vehicle front |

REMOVAL

1. Remove the LH and RH rear combination lamps. Refer to [EXL-153. "Removal and Installation"](#).
2. Remove the mudguards (if equipped). Refer to [EXT-26. "Removal and Installation"](#).
3. Remove the rear fender protectors. Refer to [EXT-25. "Removal and Installation of Rear Fender Protector"](#).
4. Remove the LH and RH rear fascia strut lower bolts.
5. Remove the rear fascia lower stay bolts.
6. Remove the fascia front upper bolts near the wheel opening.
7. Release the left pinch rail clips and remove the LH side of rear bumper fascia from the quarter panel.
8. Release the right pinch rail clips and remove the RH side of the rear bumper fascia from the quarter panel.
9. Remove the fascia rear upper bolts near the rear combination lamps LH/RH.
10. Remove the rear bumper fascia.
11. Disconnect the harness on left side of tow hitch.
12. Remove the Intelligent Key antenna (if equipped) from the rear bumper reinforcement, then remove rear bumper reinforcement.
13. Remove the drafter duct from the lower side of LH quarter panel.
14. Remove the rear valance nuts and bolts, then remove the rear valance.

INSTALLATION

Installation is in the reverse order of removal.

REAR BUMPER

< REMOVAL AND INSTALLATION >

- Apply sealant to clips securing upper step pad during installation.

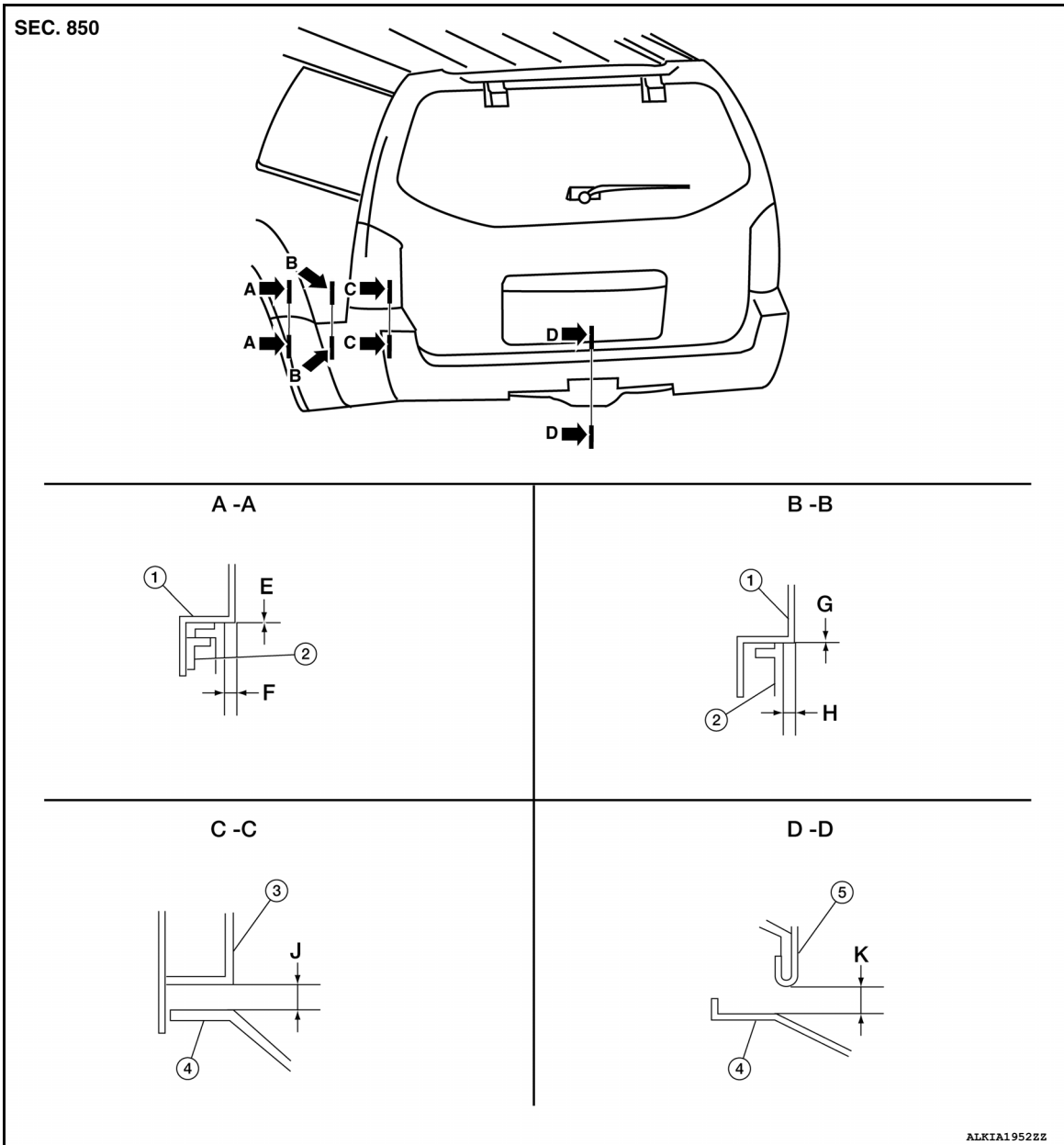

1. Rear bumper fascia
2. Bed side outer LH
3. Rear combination lamp
4. Step pad
5. Back door

Units: mm (in)

Portion	Measurement	Standard	Difference (MAX)
A-A	E Clearance	0.0 (0.000)	+ 1.0 (0.039)
	F Surface height	0.8 (0.031)	+ 1.0 (0.039)
B-B	G Clearance	0.0 (0.000)	± 1.0 (0.039)
	H Surface height	0.8 (0.031)	± 1.0 (0.039)
C-C	J Clearance	3.0 (0.118)	± 1.5 (0.059)
D-D	K Clearance	7.2 (0.283)	± 2.0 (0.079)

FRONT GRILLE

< REMOVAL AND INSTALLATION >

FRONT GRILLE

Removal and Installation

INFOID:00000006245333

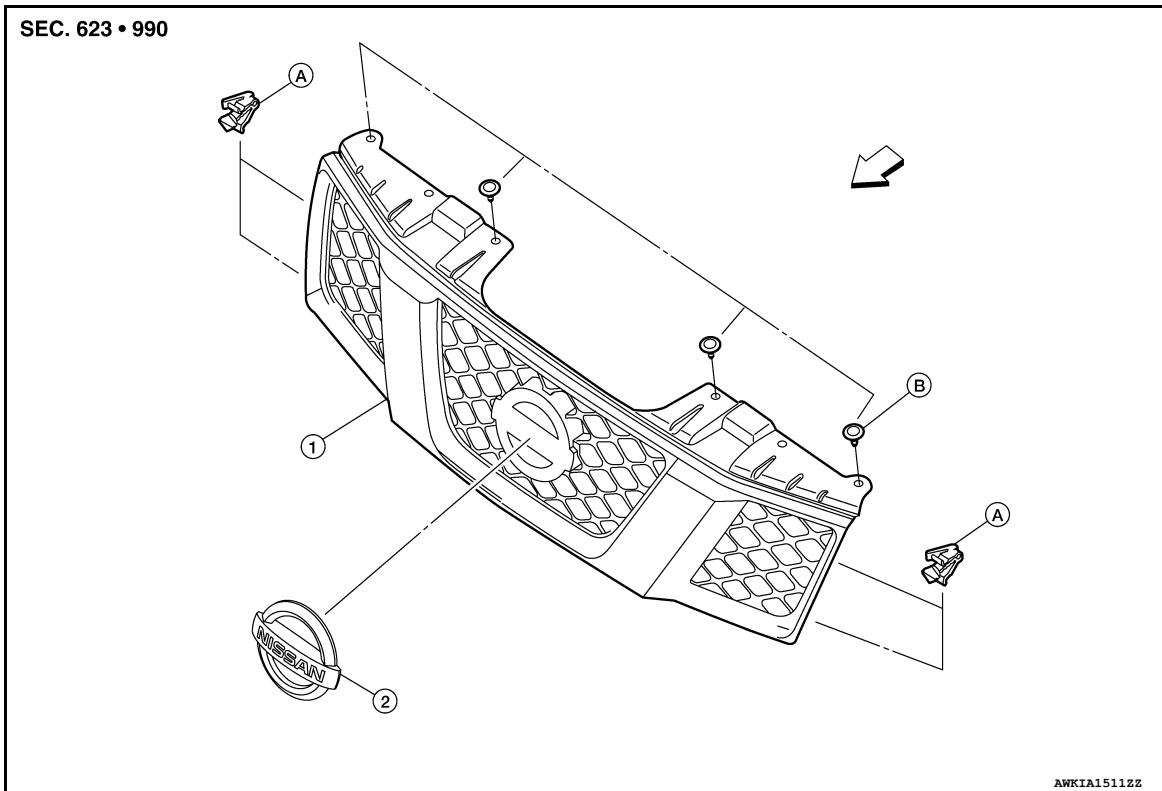

- 1. Front grille
- B. Clips C205

- 2. Front emblem
- ← Vehicle front

- A. Clips CG101

REMOVAL

1. Remove the upper clips from the front grille.
2. Twist and release the LH and RH side clips and release the top of the front grille.
3. Detach the lower front grille clips and remove the front grille.
4. Remove the front emblem (if necessary).

INSTALLATION

Installation is in the reverse order of removal.

COWL TOP

< REMOVAL AND INSTALLATION >

COWL TOP

Removal and Installation

INFOID:00000006245334

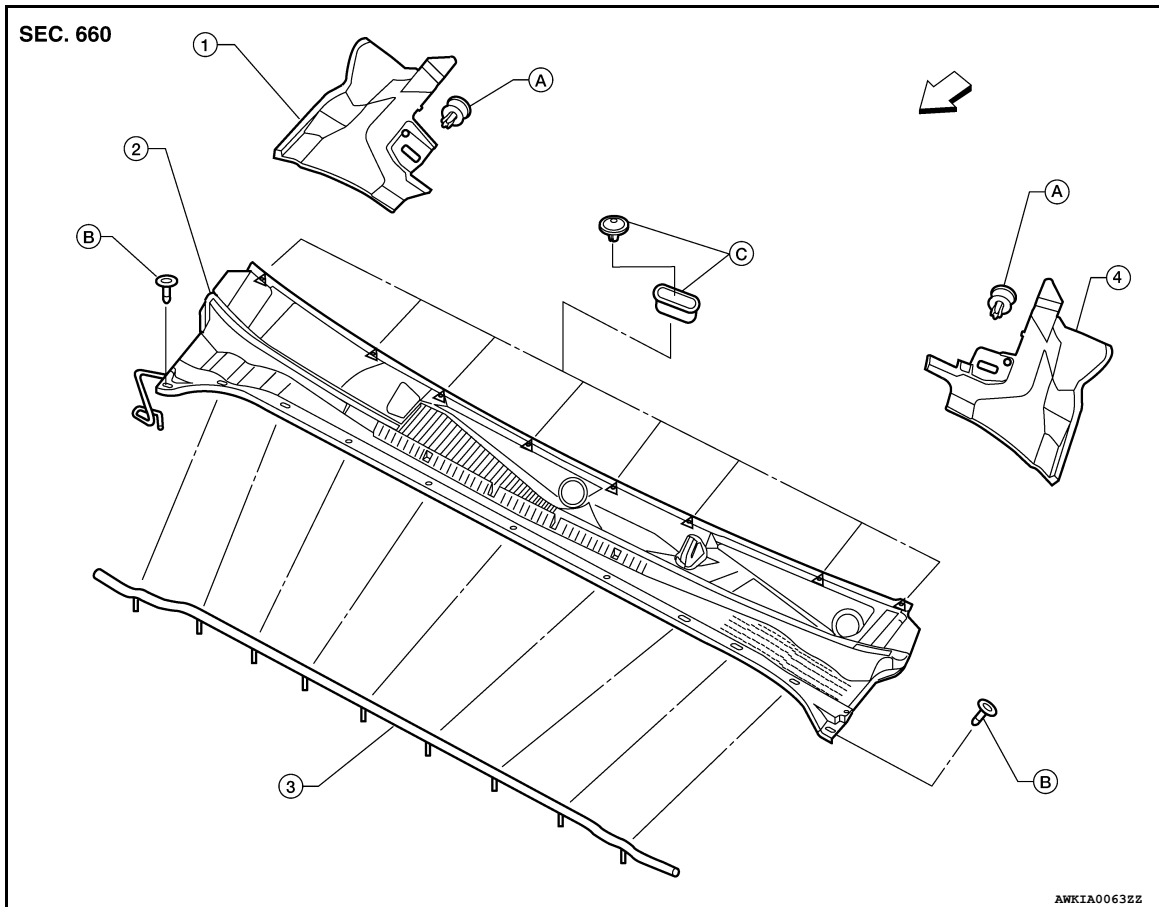

- | | | |
|--------------------------|-----------------|------------------|
| 1. Cowl top extension RH | 2. Cowl top | 3. Cowl top seal |
| 4. Cowl top extension LH | A. Clip C205 | B. Clip C103 |
| C. Grommet CF110 | ↶ Vehicle front | |

REMOVAL

1. Remove the front wiper arms. Refer to [WW-70, "Removal and Installation"](#).
2. Remove the cowl top seal.
3. Remove the cowl top clips and lift the cowl top, disconnect the washer tubes from the washer nozzles and remove the cowl top.
4. Release the clips and remove the LH and RH cowl top extensions.

INSTALLATION

Installation is in the reverse order of removal.

A
B
C
D
E
F
G
H
I
J
EXT
L
M
N
O
P

FRONT FENDER

< REMOVAL AND INSTALLATION >

FRONT FENDER

Removal and Installation

INFOID:000000006245335

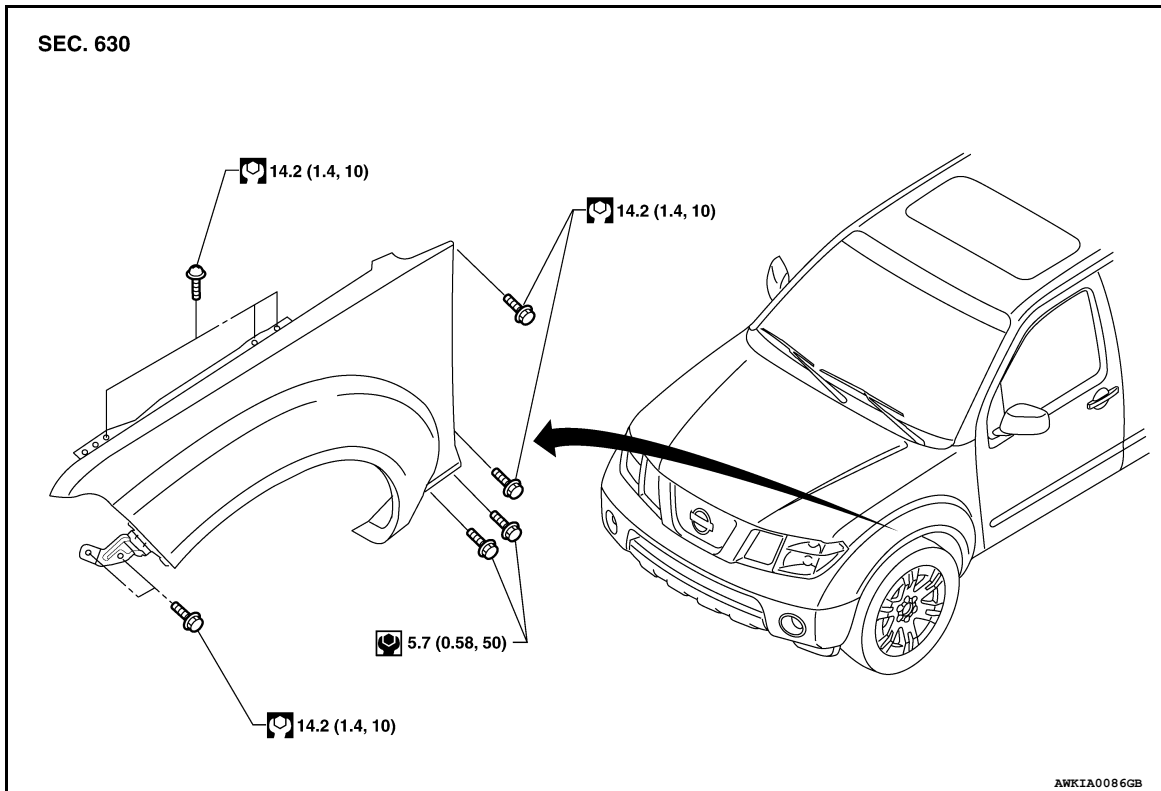

REMOVAL

1. Remove the LH and RH headlamp assemblies. Refer to [EXL-145, "Removal and Installation"](#).
2. Remove the front fender protector. Refer to [EXT-24](#).
3. Remove the mudguard (if equipped). Refer to [EXT-27, "Removal and Installation"](#).
4. Remove the front bumper fascia. Refer to [EXT-15, "Removal and Installation"](#).
5. Remove the hood prop rod and hood prop rod hold down clip.
6. Remove the front fender bolts from hoodledge and the dash panel.
7. Remove the front fender bolts from the rocker panel and the radiator core support member.
8. Remove the front fender.

INSTALLATION

Installation is in the reverse order of removal.

LICENSE LAMP FINISHER

< REMOVAL AND INSTALLATION >

LICENSE LAMP FINISHER

Removal and Installation

INFOID:000000006245336

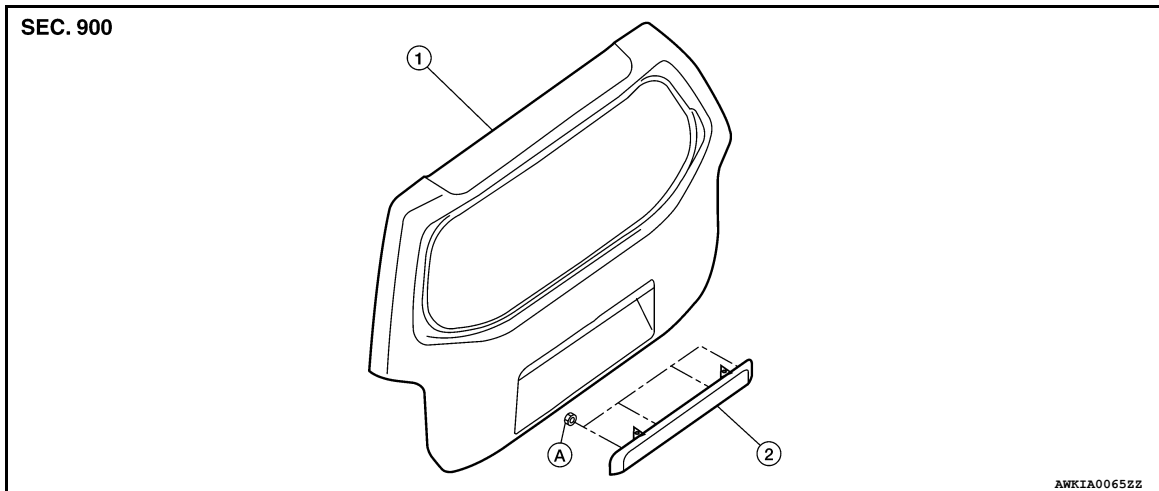

1. Back door

2. License lamp finisher

A. License lamp finisher nuts

REMOVAL

1. Remove the back door finisher. Refer to [INT-27, "Removal and Installation"](#).
2. Remove the vapor barrier plastic.
3. Remove the license lamp finisher nuts and remove the license lamp finisher.

INSTALLATION

Installation is in the reverse order of removal.

A
B
C
D
E
F
G
H
I
J
L
M
N
O
P

EXT

FENDER PROTECTOR

< REMOVAL AND INSTALLATION >

FENDER PROTECTOR

Component

INFOID:00000006245337

Front Fender Protector

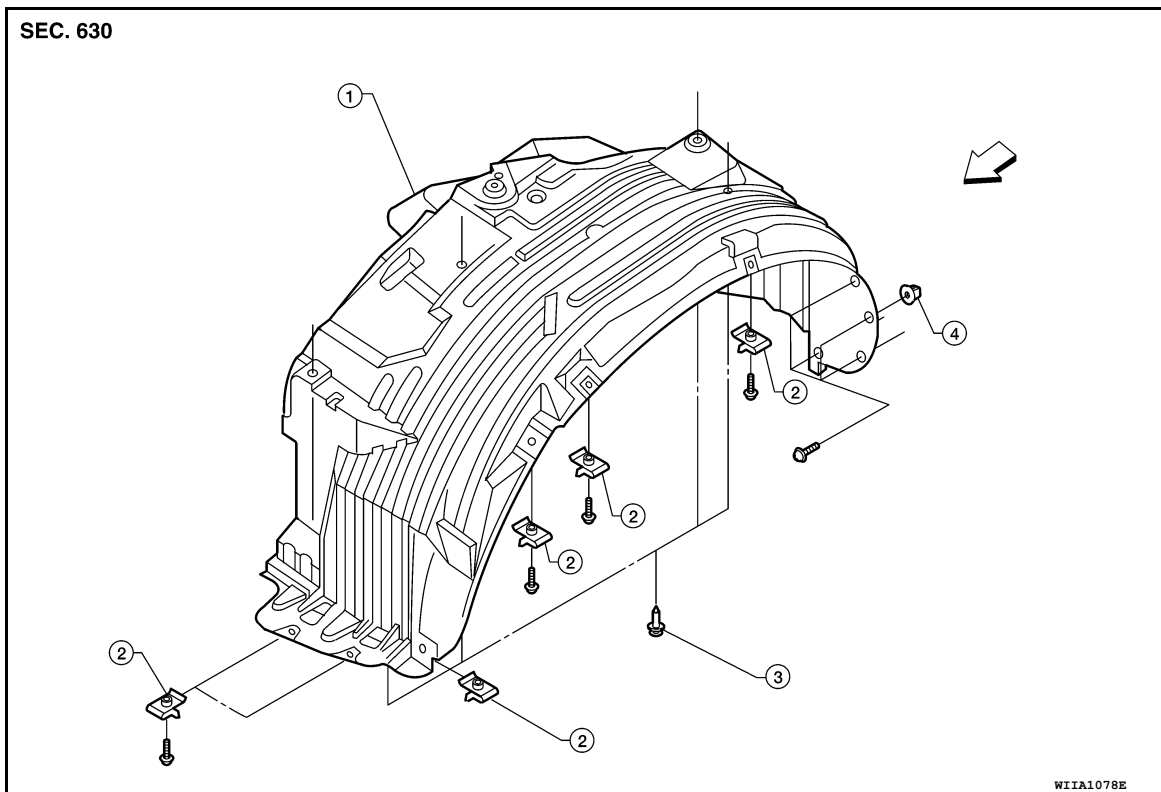

- 1. Front fender protector LH shown
 - 2. J-Nut
 - 3. Clip C205
 - 4. Grommet
- ← Vehicle front

Rear Fender Protector

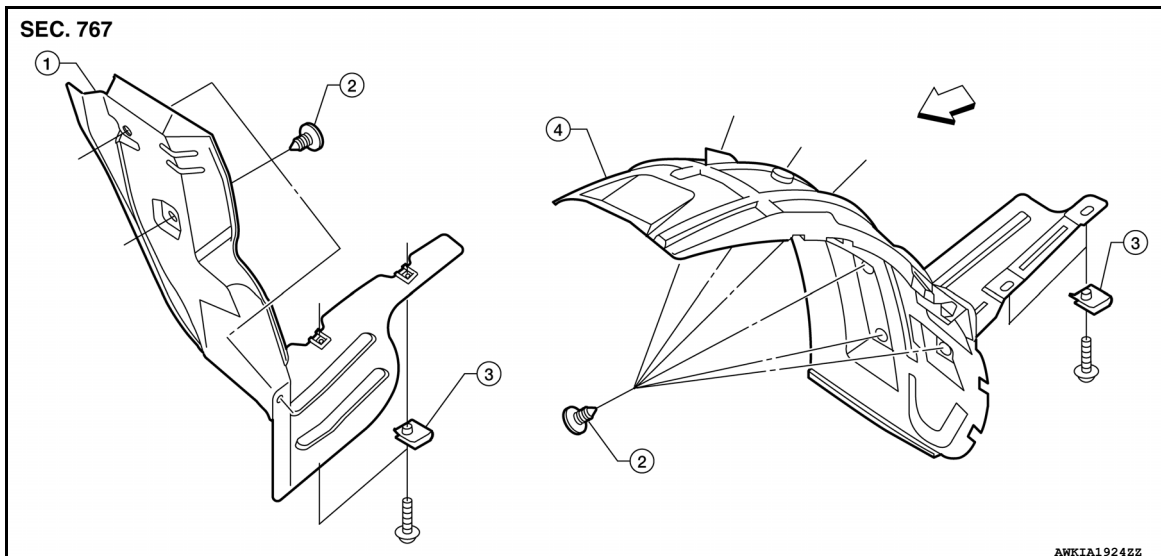

- 1. Rear fender protector RH
 - 2. Clips C103
 - 3. J-Nuts
 - 4. Rear fender protector LH
- ← Vehicle front

FENDER PROTECTOR

< REMOVAL AND INSTALLATION >

Removal and Installation of Front Fender Protector

INFOID:000000006245338

REMOVAL

1. Remove the front mudguard (if equipped). Refer to [EXT-27, "Removal and Installation"](#).
2. Remove the screws.
3. Remove the plastic clips.
4. Remove the front fender protector.

INSTALLATION

Installation is in the reverse order of removal.

Removal and Installation of Rear Fender Protector

INFOID:000000006245339

REMOVAL

1. Remove the rear mudguard (if equipped). Refer to [EXT-27, "Removal and Installation"](#).
2. Remove the screws.
3. Remove the plastic clips.
4. Remove the rear fender protector.

INSTALLATION

Installation is in the reverse order of removal.

A
B
C
D
E
F
G
H
I
J
L
M
N
O
P

EXT

MUDGUARD

< REMOVAL AND INSTALLATION >

MUDGUARD

Removal and Installation

INFOID:000000006827752

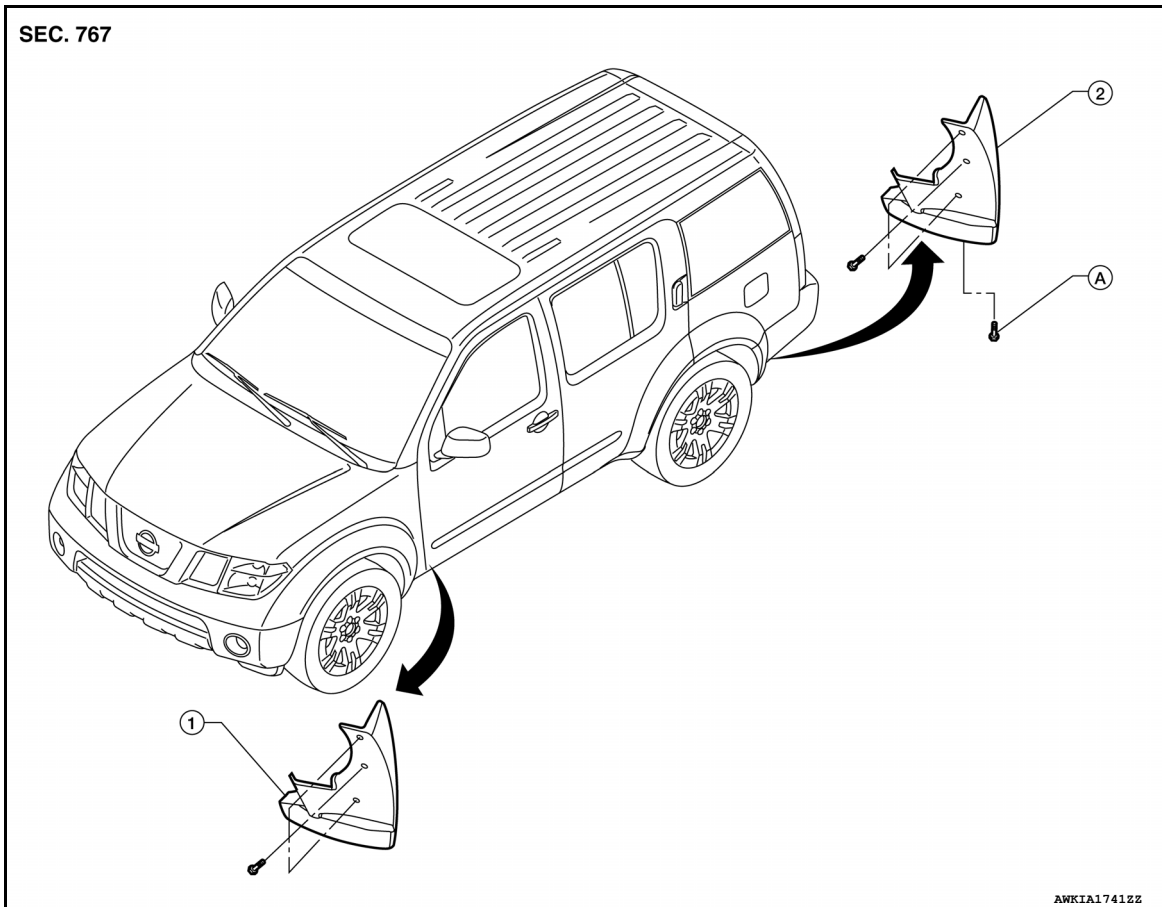

1. Front mudguard

2. Rear mudguard

A. Clip C205

REMOVAL

1. Remove the front mudguard screws, then remove the front mudguard.
2. Remove the rear mudguard clips and screws and remove the rear mudguard.

INSTALLATION

Installation is in the reverse order of removal.

RUNNING BOARDS

< REMOVAL AND INSTALLATION >

RUNNING BOARDS

Removal and Installation

INFOID:00000006245340

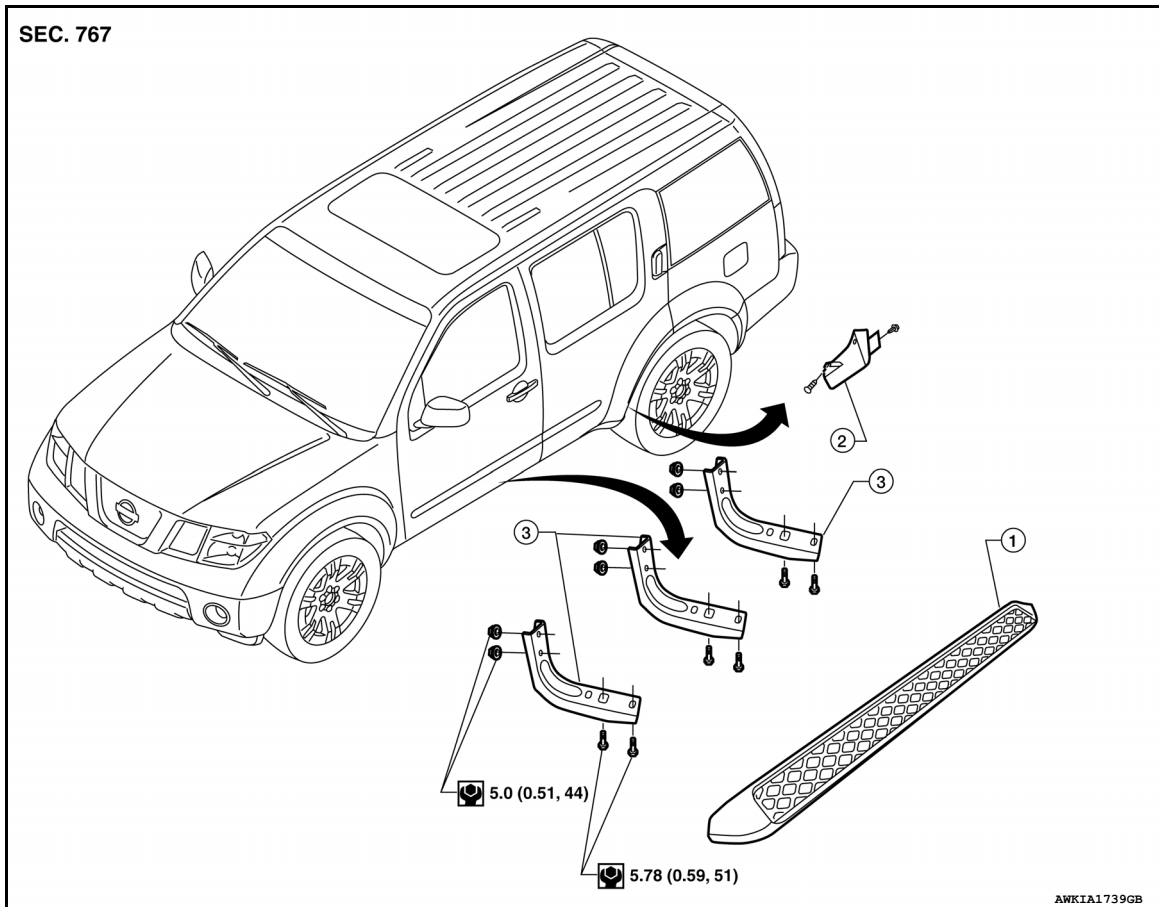

1. Running board

2. Rear wheel wind deflector

3. Running board bracket

REMOVAL

1. Remove the bolts and remove the running board from the running board brackets.
2. Remove the nuts and remove the running board brackets from the chassis.
3. Remove the screw and clip and remove the wind deflector.

INSTALLATION

Installation is in the reverse order of removal.

ROOF RACK

< REMOVAL AND INSTALLATION >

ROOF RACK

Removal and Installation

INFOID:000000006245341

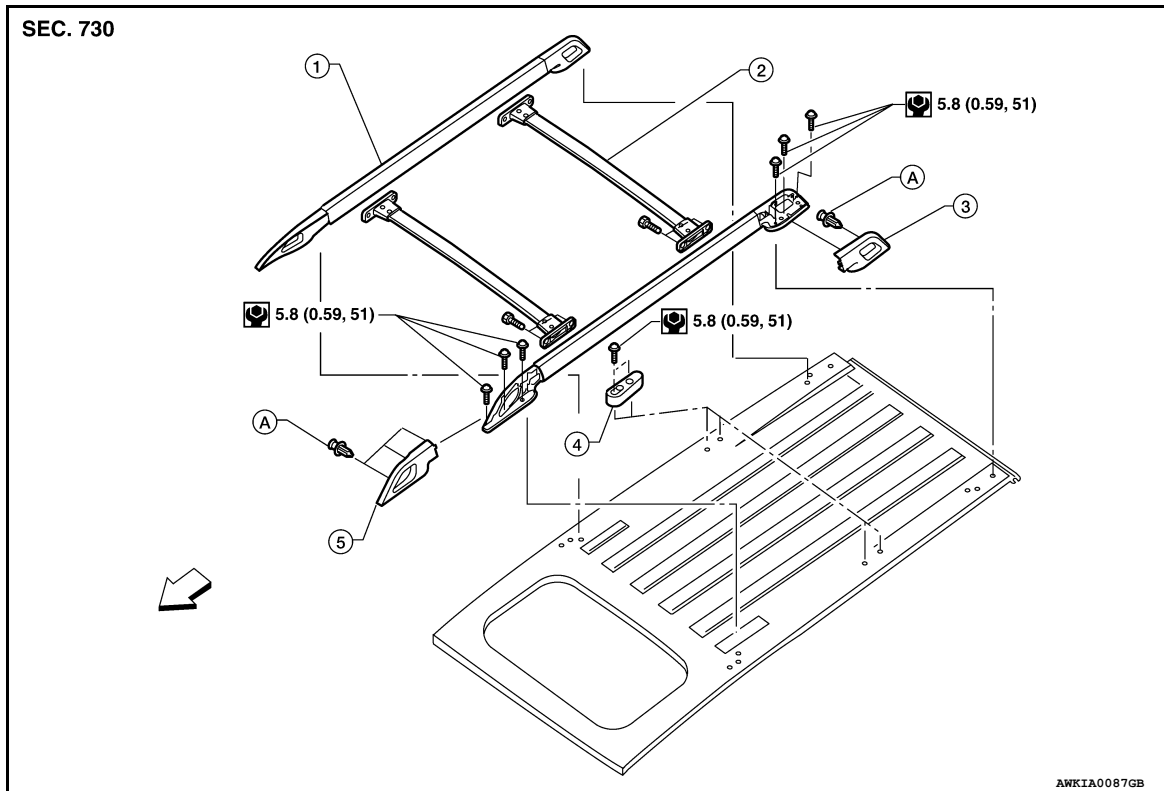

- | | | |
|---------------------|---------------------------------|--------------------------|
| 1. Slide rail | 2. Fixed crossbar (if equipped) | 3. Slide rail cover rear |
| 4. Center stanchion | 5. Slide rail cover front | A. Clip C101 |
- ↶ Vehicle front

REMOVAL

1. Pry outward releasing the clips and remove the slide rail cover front LH and RH.
2. Pry outward releasing the clips and remove the slide rail cover rear LH and RH.
3. Remove the bolts and remove front and rear fixed crossbars (if equipped) from slide rails.
4. Remove the bolts from the slide rails LH and RH.
5. Shift the slide rails forward to disengage from the center stanchion and remove.
6. Remove the bolts and remove the center stanchions LH and RH.

INSTALLATION

Installation is in the reverse order of removal.

DOOR OUTSIDE MOLDING

< REMOVAL AND INSTALLATION >

DOOR OUTSIDE MOLDING

Removal and Installation

INFOID:000000006245342

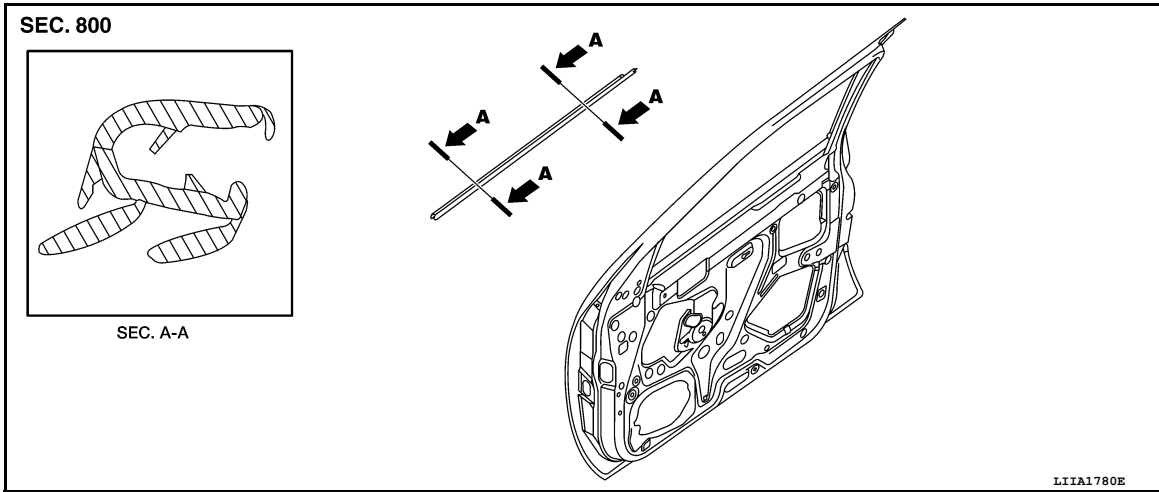

DOOR OUTSIDE MOLDING

Removal

1. Lift molding from the front side off of flange.
2. Remove the door outside molding.

Installation

Installation is in the reverse order of removal.

A
B
C
D
E
F
G
H
I
J
L
M
N
O
P

EXT

SIDE GUARD MOLDING

< REMOVAL AND INSTALLATION >

SIDE GUARD MOLDING

Removal and Installation

INFOID:00000006245343

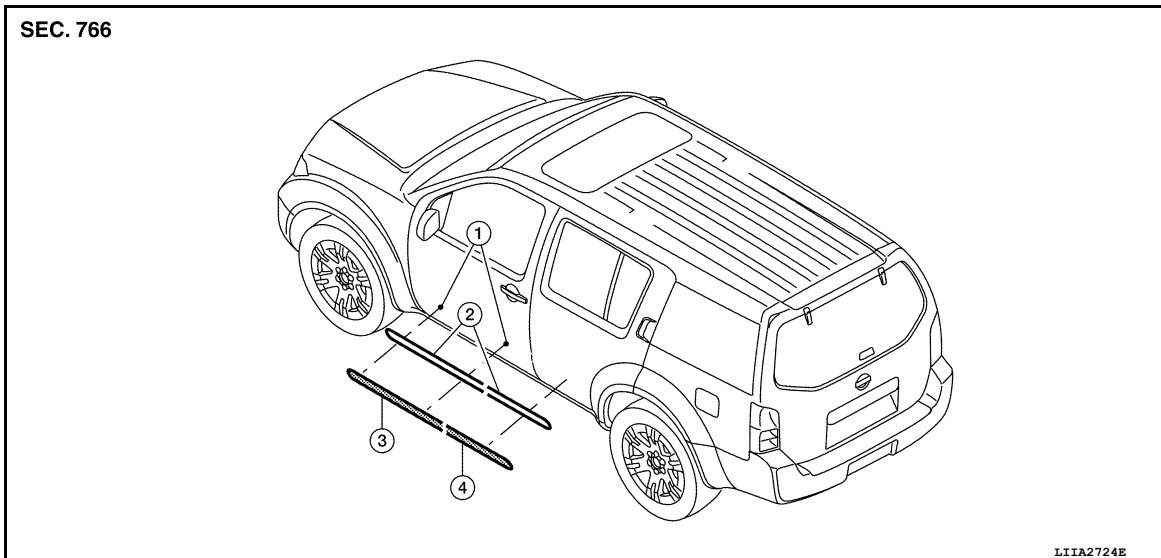

1. Alignment hole
2. Double-faced adhesive tape
3. Front door side guard molding
4. Rear door side guard molding

Removal

CAUTION:

Never apply tack-paper adhesive remover to body panel surface finished with lacquer-based paints.

- Original side guard molding is affixed to body panel with double-faced adhesive tape.
1. Heat molding to between 30° and 40°C (86° to 104°F) with a heat gun.
 2. Raise end of molding to release clips, then cut away tape to remove molding. Remove all traces of tape.

Installation

- On vehicles coated with Hard Clear Coat, use double-faced 3M adhesive tape Product No. 4210 or equivalent, after priming with 3M primer Product No. N200 or C-100 or equivalent.
 - The repair parts are also affixed with double-faced adhesive tape.
 - To re-use existing molding, clean all traces of double-faced adhesive tape from the molding and apply new double-faced adhesive tape to the molding.
1. Clean the panel surface with isopropyl alcohol or equivalent to degrease the surface.
 2. Heat the panel and molding tape surface to 30° to 40°C (86° to 104°F).
 3. Apply the side guard molding.
 - Remove the backing sheet from the tape surface.
 - Align the locating pin into the hole in the outer door.
 - Continue aligning the pins into their corresponding holes in the outer door during installation.
 4. Press ends by hand and use a roller to apply 5 kg-f (11 lbs-f) to press molding to door surface.
 - Apply even pressure along molding to insure proper wet out.

CAUTION:

To secure contact, do not wash vehicle for 24 hours after installation.