

SECTION **RSU**
 REAR SUSPENSION

A
 B
 C
 D
 F
 G
 H
 I
 J
 K
 L
 M
 N
 O
 P

RSU

CONTENTS

PRECAUTION	2	REAR SUSPENSION ASSEMBLY	10
PRECAUTIONS	2	Component	10
Precaution for Supplemental Restraint System (SRS) "AIR BAG" and "SEAT BELT PRE-TENSIONER"	2	SHOCK ABSORBER	11
Precaution Necessary for Steering Wheel Rotation After Battery Disconnect	2	Removal and Installation	11
Precaution for Rear Suspension	3	Disposal	11
PREPARATION	4	SUSPENSION ARM	12
PREPARATION	4	Removal and Installation	12
Commercial Service Tool	4	FRONT LOWER LINK	14
SYMPTOM DIAGNOSIS	5	Removal and Installation	14
NOISE, VIBRATION, AND HARSHNESS (NVH) TROUBLESHOOTING	5	REAR LOWER LINK & COIL SPRING	16
NVH Troubleshooting Chart	5	Removal and Installation	16
PERIODIC MAINTENANCE	6	STABILIZER BAR	18
REAR SUSPENSION ASSEMBLY	6	Removal and Installation	18
On-Vehicle Inspection	6	UNIT REMOVAL AND INSTALLATION	19
Wheel Alignment Inspection	6	REAR SUSPENSION MEMBER	19
SHOCK ABSORBER	9	Removal and Installation	19
Inspection	9	SERVICE DATA AND SPECIFICATIONS (SDS)	23
REMOVAL AND INSTALLATION	10	SERVICE DATA AND SPECIFICATIONS (SDS)	23
		Wheel Alignment (Unladen*)	23
		Ball Joint	23
		Wheelarch Height (Unladen*)	24

PRECAUTIONS

< PRECAUTION >

PRECAUTION

PRECAUTIONS

Precaution for Supplemental Restraint System (SRS) "AIR BAG" and "SEAT BELT PRE-TENSIONER"

INFOID:000000006245800

The Supplemental Restraint System such as "AIR BAG" and "SEAT BELT PRE-TENSIONER", used along with a front seat belt, helps to reduce the risk or severity of injury to the driver and front passenger for certain types of collision. This system includes seat belt switch inputs and dual stage front air bag modules. The SRS system uses the seat belt switches to determine the front air bag deployment, and may only deploy one front air bag, depending on the severity of a collision and whether the front occupants are belted or unbelted. Information necessary to service the system safely is included in the SR and SB section of this Service Manual.

WARNING:

- To avoid rendering the SRS inoperative, which could increase the risk of personal injury or death in the event of a collision which would result in air bag inflation, all maintenance must be performed by an authorized NISSAN/INFINITI dealer.
- Improper maintenance, including incorrect removal and installation of the SRS, can lead to personal injury caused by unintentional activation of the system. For removal of Spiral Cable and Air Bag Module, see the SR section.
- Do not use electrical test equipment on any circuit related to the SRS unless instructed to in this Service Manual. SRS wiring harnesses can be identified by yellow and/or orange harnesses or harness connectors.

PRECAUTIONS WHEN USING POWER TOOLS (AIR OR ELECTRIC) AND HAMMERS

WARNING:

- When working near the Airbag Diagnosis Sensor Unit or other Airbag System sensors with the Ignition ON or engine running, DO NOT use air or electric power tools or strike near the sensor(s) with a hammer. Heavy vibration could activate the sensor(s) and deploy the air bag(s), possibly causing serious injury.
- When using air or electric power tools or hammers, always switch the Ignition OFF, disconnect the battery, and wait at least 3 minutes before performing any service.

Precaution Necessary for Steering Wheel Rotation After Battery Disconnect

INFOID:000000006245801

NOTE:

- This Procedure is applied only to models with Intelligent Key system and NATS (NISSAN ANTI-THEFT SYSTEM).
- Remove and install all control units after disconnecting both battery cables with the ignition knob in the "LOCK" position.
- Always use CONSULT-III to perform self-diagnosis as a part of each function inspection after finishing work. If DTC is detected, perform trouble diagnosis according to self-diagnostic results.

For models equipped with the Intelligent Key system and NATS, an electrically controlled steering lock mechanism is adopted on the key cylinder.

For this reason, if the battery is disconnected or if the battery is discharged, the steering wheel will lock and steering wheel rotation will become impossible.

If steering wheel rotation is required when battery power is interrupted, follow the procedure below before starting the repair operation.

OPERATION PROCEDURE

1. Connect both battery cables.

NOTE:

Supply power using jumper cables if battery is discharged.

2. Use the Intelligent Key or mechanical key to turn the ignition switch to the "ACC" position. At this time, the steering lock will be released.
3. Disconnect both battery cables. The steering lock will remain released and the steering wheel can be rotated.
4. Perform the necessary repair operation.

PRECAUTIONS

< PRECAUTION >

5. When the repair work is completed, return the ignition switch to the "LOCK" position before connecting the battery cables. (At this time, the steering lock mechanism will engage.)
6. Perform a self-diagnosis check of all control units using CONSULT-III.

Precaution for Rear Suspension

INFOID:000000006245802

- When installing the rubber bushings, the final tightening must be done under unladen condition and with the tires on level ground. Oil will shorten the life of the rubber bushings, so wipe off any spilled oil immediately.
- Unladen condition means the fuel tank, engine coolant and lubricants are at the full specification. The spare tire, jack, hand tools, and mats are in their designated positions. There are no passengers in the vehicle.
- After installing suspension components, check the wheel alignment.
- Lock nuts are not reusable. Always use new lock nuts for installation. New lock nuts are pre-oiled, do not apply any additional lubrication.

A

B

C

D

RSU

F

G

H

I

J

K

L

M

N

O

P

PREPARATION

< PREPARATION >

PREPARATION

PREPARATION

Commercial Service Tool

INFOID:000000006245803

Tool name	Description
Power tool  PIIB1407E	Removing bolts, screws and nuts

NOISE, VIBRATION, AND HARSHNESS (NVH) TROUBLESHOOTING

< SYMPTOM DIAGNOSIS >

SYMPTOM DIAGNOSIS

NOISE, VIBRATION, AND HARSHNESS (NVH) TROUBLESHOOTING

NVH Troubleshooting Chart

INFOID:000000006245804

Use chart below to help you find the cause of the symptom. If necessary, repair or replace these parts.

Symptom	Possible cause and SUSPECTED PARTS										Reference page						
	Improper installation, looseness	Shock absorber deformation, damage or deflection	Bushing or mounting deterioration	Parts interference	Spring fatigue	Suspension looseness	Incorrect wheel alignment	Stabilizer bar fatigue	PROPELLER SHAFT	DIFFERENTIAL	FRONT SUSPENSION	FRONT AXLE	TIRES	ROAD WHEEL	DRIVE SHAFT	BRAKES	STEERING
Noise	x	x	x	x	x	x			x	x	x	x	x	x	x	x	
Shake	x	x	x	x		x			x		x		x	x	x	x	x
Vibration	x	x	x	x	x				x		x		x		x		x
Shimmy	x	x	x	x			x				x		x	x		x	x
Shudder	x	x	x								x		x	x		x	x
Poor quality ride or handling	x	x	x	x	x		x	x			x		x	x			

x: Applicable

A
B
C
D
E
F
G
H
I
J
K
L
M
N
O
P

RSU

REAR SUSPENSION ASSEMBLY

< PERIODIC MAINTENANCE >

PERIODIC MAINTENANCE

REAR SUSPENSION ASSEMBLY

On-Vehicle Inspection

INFOID:000000006245805

- Check all of the component mountings for any excessive looseness, or backlash. Repair or replace the components as necessary.
- Check the components for any excessive wear, damage, or abnormal conditions. Repair or replace the components as necessary.
- Check the shock absorbers for any oil leaks or damage, and replace as necessary.

Wheel Alignment Inspection

INFOID:000000006245806

Rear Wheel Alignment Adjusting Bolts

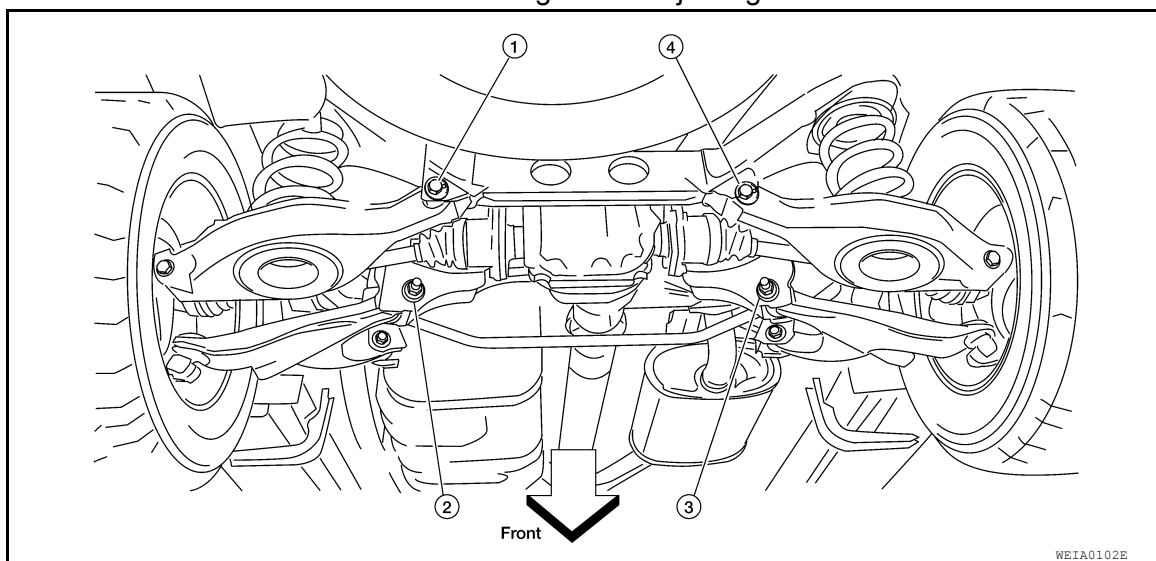

1. Rear lower link adjusting bolt, LH
2. Front lower link adjusting bolt, LH
3. Front lower link adjusting bolt, RH
4. Rear lower link adjusting bolt, RH

PRELIMINARY INSPECTION

WARNING:

Always adjust the alignment with the vehicle on a flat surface.

NOTE:

If alignment is out of specification, inspect and replace any damaged or worn rear suspension parts before making any adjustments.

1. Check and adjust the wheel alignment with the vehicle under unladen conditions. "Unladen conditions" means that the fuel, coolant, and lubricants are all full, and that the spare tire, jack, hand tools and mats are in their designated positions, and there are no passengers in the vehicle.
2. Check the tires for incorrect air pressure and excessive wear. Refer to [WT-54, "Tire"](#).
3. Check the wheels for runout and damage. Refer to [WT-49, "Inspection"](#).
4. Check the wheel bearing axial end play.

Axial end play : Refer to [RAX-15, "Wheel Bearing"](#).

5. Check the shock absorbers for any oil leaks or damage.
6. Check each mounting point of the suspension components for any excessive looseness or damage.
7. Check each link, arm, and the rear suspension member for any damage.
8. Check the vehicle height. Refer to [FSU-26, "Wheelarch Height \(Unladen*1\)"](#).

GENERAL INFORMATION AND RECOMMENDATIONS

1. A Four-Wheel Thrust Alignment should be performed.

REAR SUSPENSION ASSEMBLY

< PERIODIC MAINTENANCE >

- This type of alignment is recommended for any NISSAN vehicle.
 - The four-wheel "thrust" process helps ensure that the vehicle is properly aligned and the steering wheel is centered.
 - The alignment machine itself should be capable of accepting any NISSAN vehicle.
 - The alignment machine should be checked to ensure that it is level.
2. Make sure the alignment machine is properly calibrated.
 - Your alignment machine should be regularly calibrated in order to give correct information.
 - Check with the manufacturer of your specific alignment machine for their recommended Service/Calibration Schedule.

THE ALIGNMENT PROCESS

IMPORTANT: Use only the alignment specifications listed in this Service Manual. Refer to [RSU-23, "Wheel Alignment \(Unladen*\)"](#).

1. When displaying the alignment settings, many alignment machines use "indicators": (Green/red, plus or minus, Go/No Go). **Do NOT use these indicators.**
 - The alignment specifications programmed into your alignment machine that operate these indicators may not be correct.
 - This may result in an ERROR.
 2. Most camera-type alignment machines are equipped with both "Rolling Compensation" method and optional "Jacking Compensation" method to "compensate" the alignment targets or head units. "Rolling Compensation" is the preferred method.
 - If using the "Rolling Compensation" method, after installing the alignment targets or head units, push or pull on the rear wheel to move the vehicle. Do not push or pull on the vehicle body.
 - if using the "Jacking Compensation" method, after installing the alignment targets or head units, raise the vehicle and rotate the wheels 1/2 turn both ways.
- NOTE:**
Do not use the "Rolling Compensation" method if you are using sensor-type alignment equipment.
• Follow all instructions for the alignment machine you are using for more information.

CAMBER

1. Measure camber of both the right and left wheels with a suitable alignment gauge and adjust as necessary to specification.

Camber : Refer to [RSU-23, "Wheel Alignment \(Unladen*\)"](#).

2. If outside of the specified value, adjust the camber using the adjusting bolt in the front lower link.

CAUTION:

After adjusting the camber then check the toe-in.

NOTE:

Camber changes about 0° 5' with each graduation of the adjusting bolt.

3. Tighten the adjusting bolt nuts to specification.

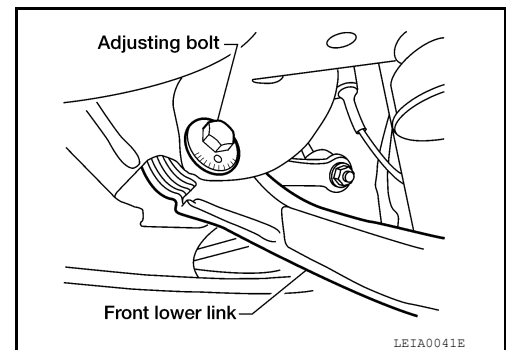

TOE-IN

- Measure the toe-in of the rear wheels. If toe-in is out of specification, inspect and replace any damaged or worn rear suspension parts before adjusting.

Total toe-in : Refer to [RSU-23, "Wheel Alignment \(Unladen*\)"](#).

REAR SUSPENSION ASSEMBLY

< PERIODIC MAINTENANCE >

- Adjust toe-in by turning adjusting bolt on rear lower link.

NOTE:

- Toe changes about 1.5 mm (0.059 in) [One side] with each graduation of the adjusting bolt.
- Tighten the adjusting bolt nut to the specified torque.

Adjusting bolt nut : Refer to [RSU-10, "Component"](#).

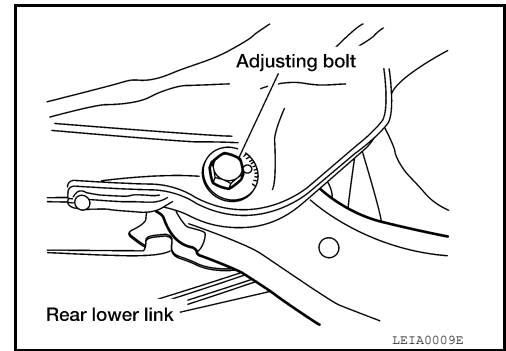

SHOCK ABSORBER

< PERIODIC MAINTENANCE >

SHOCK ABSORBER

Inspection

INFOID:000000006245807

- Check for oil leakage on welded or gland packing portions.
- Check the shock absorber for smooth operation through a full stroke, both compression and extension.

A

B

C

D

RSU

F

G

H

I

J

K

L

M

N

O

P

REAR SUSPENSION ASSEMBLY

< REMOVAL AND INSTALLATION >

REMOVAL AND INSTALLATION

REAR SUSPENSION ASSEMBLY

Component

INFOID:000000006245808

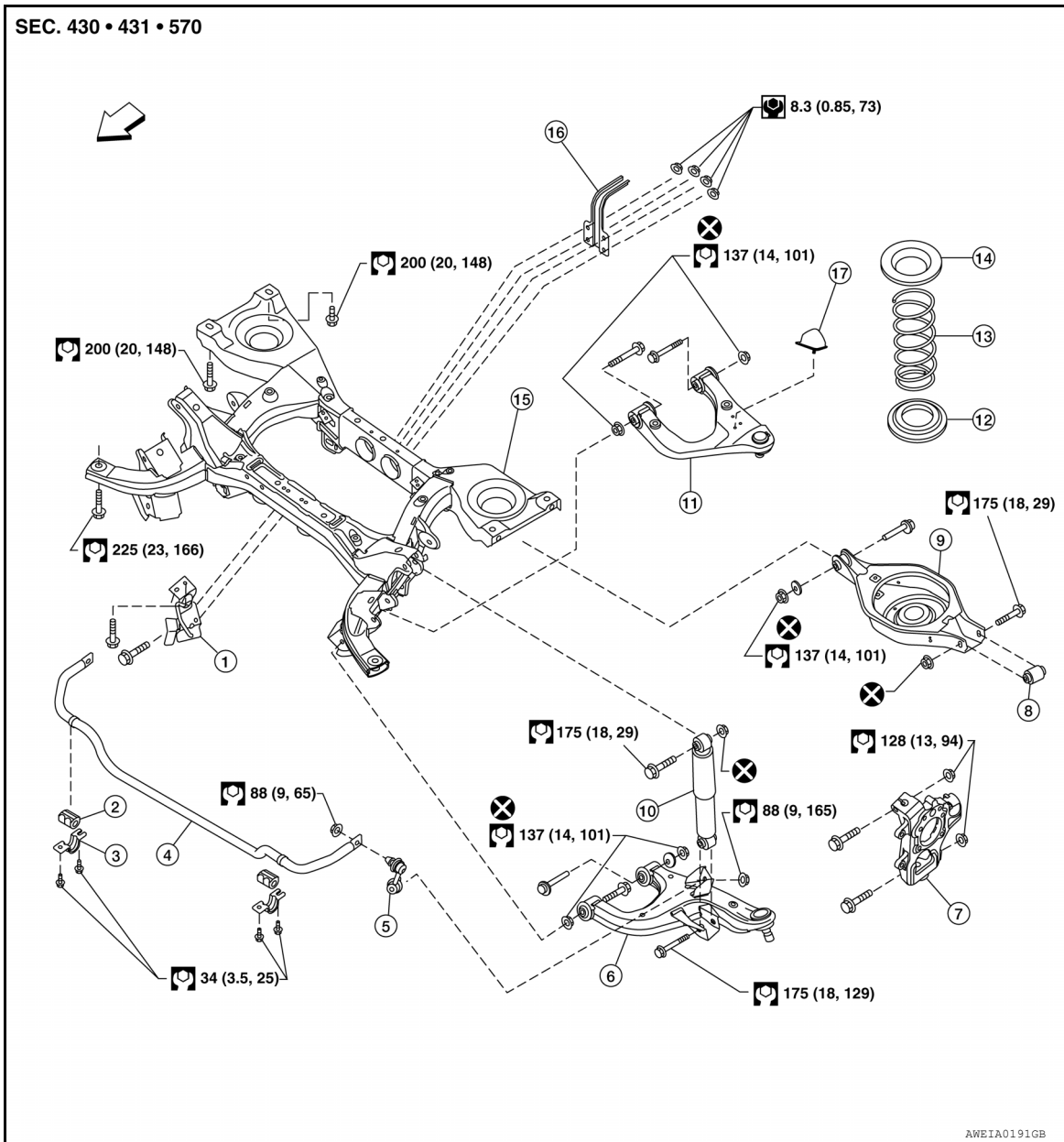

- | | | |
|---------------------------|---------------------------|----------------------------|
| 1. Seat belt latch anchor | 2. Stabilizer bar bushing | 3. Stabilizer bar clamp |
| 4. Stabilizer bar | 5. Connecting rod | 6. Front lower link |
| 7. Knuckle | 8. Bushing | 9. Rear lower link |
| 10. Shock absorber | 11. Suspension arm | 12. Lower rubber seat |
| 13. Coil spring | 14. Upper rubber seat | 15. Rear suspension member |
| 16. Spare tire bracket | 17. Bound bumper | |

SHOCK ABSORBER

< REMOVAL AND INSTALLATION >

SHOCK ABSORBER

Removal and Installation

INFOID:000000006245809

REMOVAL

1. Remove the wheel and tire assembly using power tool. Refer to [WT-50, "Adjustment"](#).
2. Position a suitable jack under the front lower link to support the shock absorber.
3. Remove the shock absorber upper and lower end bolts using power tool.
4. Remove the shock absorber.

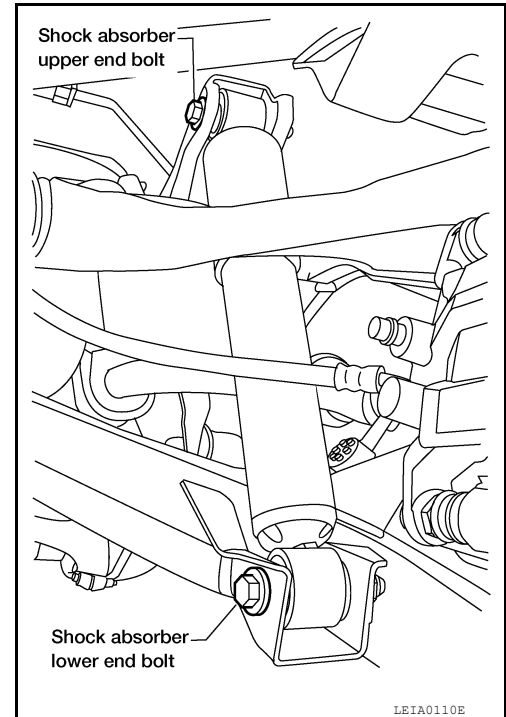

INSTALLATION

Installation is in the reverse order of removal.

- Tighten the shock absorber bolts to specification. Refer to [RSU-10, "Component"](#).

Disposal

INFOID:000000006245810

1. Set shock absorber horizontally with the piston rod fully extended.
2. Drill 2 – 3 mm (0.08 – 0.12 in) hole at the position (●) from top as shown in the figure to release gas gradually.

CAUTION:

- Wear eye protection (safety glasses).
- Wear gloves.
- Be careful with metal chips or oil blown out by the compressed gas.

NOTE:

- Drill vertically in this direction (←).
- Directly to the outer tube avoiding brackets.
- The gas is clear, colorless, odorless, and harmless.

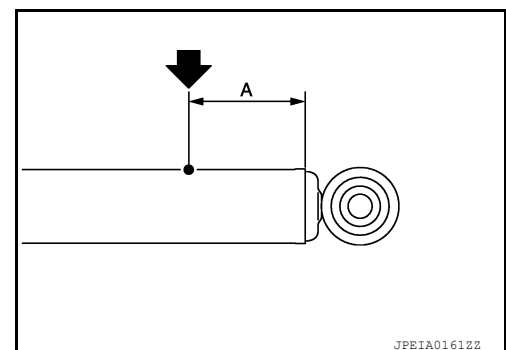

A : 20 – 30 mm (0.79 – 1.18 in)

3. Position the drilled hole downward and drain oil by moving the piston rod several times.

CAUTION:

Dispose of drained oil according to the law and local regulations.

SUSPENSION ARM

< REMOVAL AND INSTALLATION >

SUSPENSION ARM

Removal and Installation

INFOID:000000006245811

REMOVAL

1. Remove the wheel and tire assembly using power tool. Refer to [WT-50, "Adjustment"](#).
2. Remove the brake caliper without disconnecting the brake hoses, using power tool. Reposition the brake caliper out of the way using a suitable wire. Refer to [BR-48, "Removal and Installation of Brake Caliper and Disc Rotor"](#).
3. Position a suitable jack under the front lower link to support the knuckle.
4. Remove the shock absorber upper and lower end bolts using power tool, and remove the shock absorber.

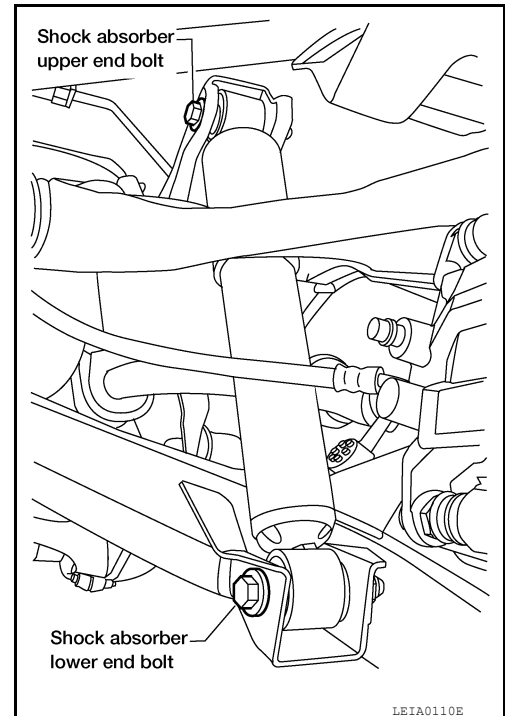

5. Remove the suspension arm upper nuts and bolts on the suspension member side using power tool.
6. Remove the suspension arm pinch bolt and nut on the knuckle side using power tool.
7. Disconnect the suspension arm from the knuckle using a soft hammer.

CAUTION:

Do not damage the ball joint with the soft hammer.

8. Remove the suspension arm.
9. Remove the bound bumper from the suspension arm if necessary to transfer to the new suspension arm.

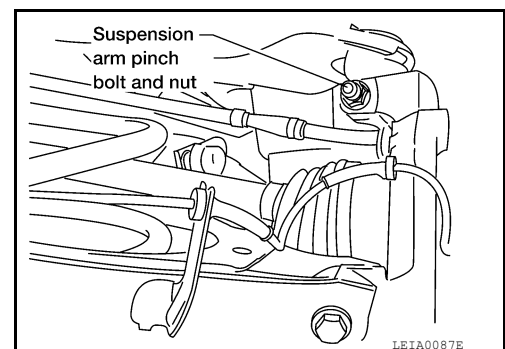

INSPECTION AFTER REMOVAL

SUSPENSION ARM

< REMOVAL AND INSTALLATION >

- Check the suspension arm for damage, cracks, deformation and replace if necessary.
- Check the rubber bushing for damage, cracks and deformation. Replace suspension arm assembly if necessary.
- Check the ball joint. Replace the suspension arm assembly if any of the following exists:
 - Ball stud is worn.
 - Joint is hard to swing.
 - Play in axial direction is excessive.
- Before checking, turn the ball joint at least 10 revolutions so that the ball joint is properly broken in.

Swinging force (A) : Refer to [RSU-23, "Ball Joint"](#).

Turning force (B) : Refer to [RSU-23, "Ball Joint"](#).

Vertical end play (C) : Refer to [RSU-23, "Ball Joint"](#).

Height (D) : Refer to [RSU-23, "Ball Joint"](#).

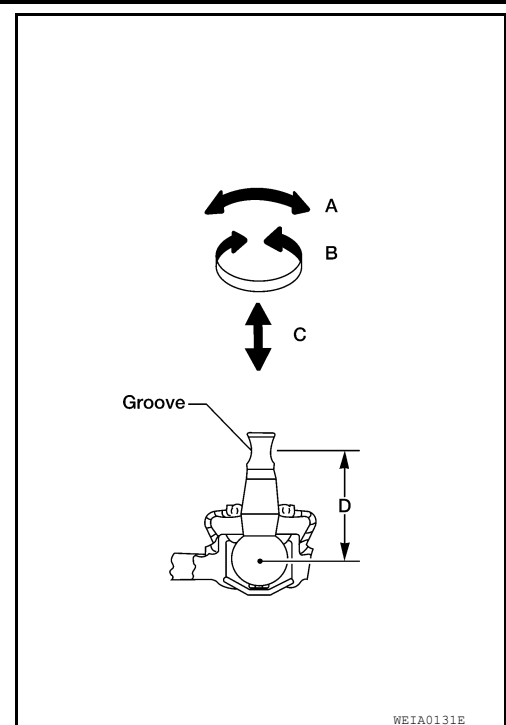

INSTALLATION

Installation is in the reverse order of removal.

- Tighten the nuts and bolts to specification. Refer to [RSU-10, "Component"](#).
- Perform final tightening of the nuts and bolts for the links (with rubber bushings) under unladen conditions with the tires on level ground.

FRONT LOWER LINK

< REMOVAL AND INSTALLATION >

FRONT LOWER LINK

Removal and Installation

INFOID:00000006245812

REMOVAL

1. Remove the wheel and tire assembly using power tool.
2. Remove the stabilizer bar. Refer to [RSU-18, "Removal and Installation"](#).
3. Set a suitable jack under the rear lower link to relieve the coil spring tension.

NOTE:

LH side shown, RH side similar.

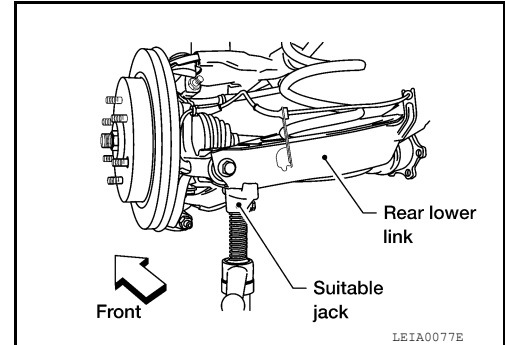

4. Remove the shock absorber lower end bolt.

NOTE:

LH side shown, RH side similar.

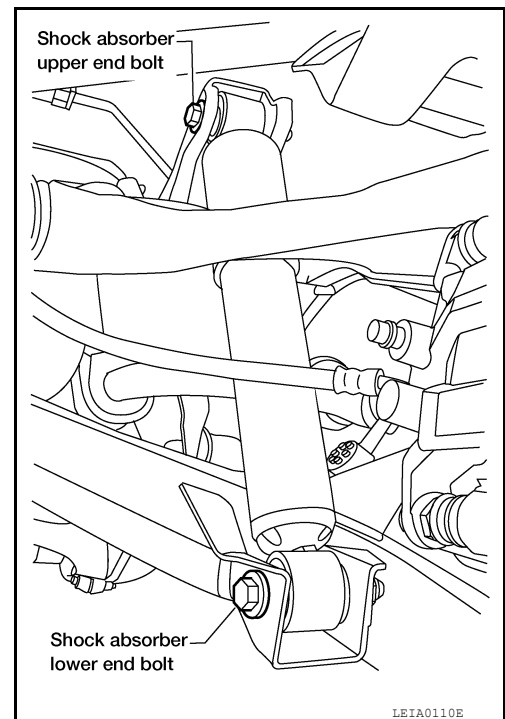

5. Remove the adjusting bolt and nut, and the bolt and nut, from the front lower link and rear suspension member using power tool.

6. Remove the front lower link pinch bolt and nut on the knuckle side using power tool.

NOTE:

LH side shown, RH side similar.

7. Disconnect the front lower link from the knuckle using a soft hammer.

CAUTION:

Do not damage the ball joint with the soft hammer.

8. Remove the front lower link.

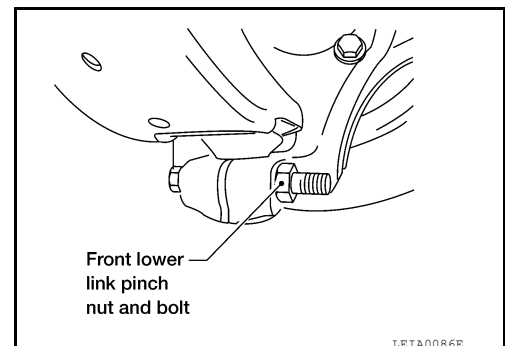

INSPECTION AFTER REMOVAL

- Check front lower link and bushing for any deformation, crack, or damage. Replace if necessary.

FRONT LOWER LINK

< REMOVAL AND INSTALLATION >

- Check rubber bushing for damage, cracks and deformation. Replace suspension arm assembly if necessary.
- Check ball joint. Replace suspension arm assembly if any of the following exists:
 - Ball stud is worn.
 - Joint is hard to swing.
 - Play in axial direction is excessive.
- Before checking, turn ball joint at least 10 revolutions so that ball joint is properly broken in.

- Swinging force (A)** : Refer to [RSU-23, "Ball Joint"](#).
Turning force (B) : Refer to [RSU-23, "Ball Joint"](#).
Vertical end play (C) : Refer to [RSU-23, "Ball Joint"](#).
Height (D) : Refer to [RSU-23, "Ball Joint"](#).

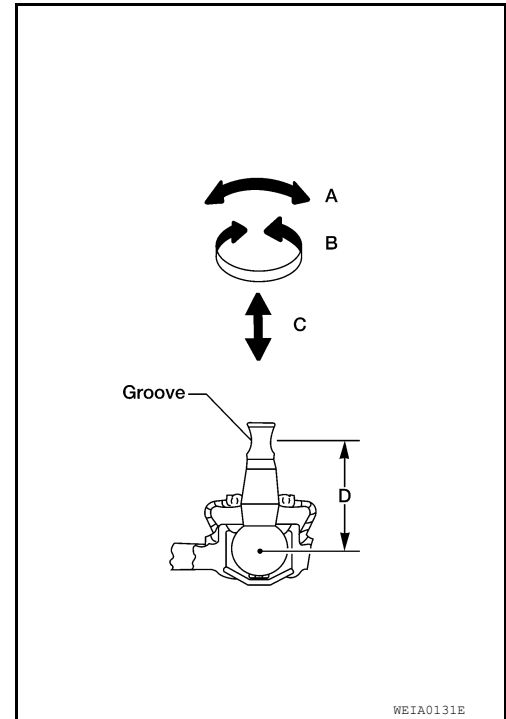

INSTALLATION

Installation is in the reverse order of removal.

- Tighten the nuts and bolts to specification. Refer to [RSU-10, "Component"](#).
- Perform the final tightening of the front lower link nuts and bolts (with rubber bushings) under unladen conditions with tires on level ground.
- Check the wheel alignment. Refer to [FSU-7, "Front Wheel Alignment"](#).

REAR LOWER LINK & COIL SPRING

< REMOVAL AND INSTALLATION >

REAR LOWER LINK & COIL SPRING

Removal and Installation

INFOID:00000006245813

REMOVAL

1. Remove the wheel and tire assembly using power tool. Refer to [WT-50. "Adjustment"](#).
2. If removing the LH rear lower link and coil spring, remove the spare wheel and tire assembly.
3. Set a suitable jack to relieve the coil spring tension and support the rear lower link.

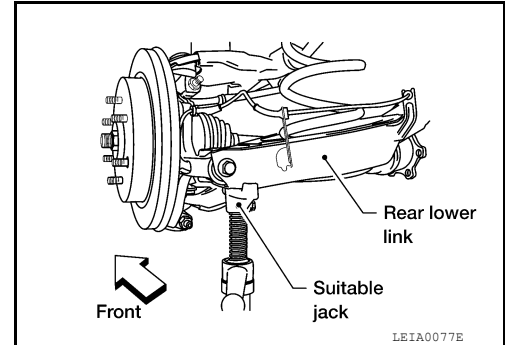

4. Loosen the rear lower link adjusting bolt and nut connected to the rear suspension member without removing the adjusting bolt and nut, using power tool.

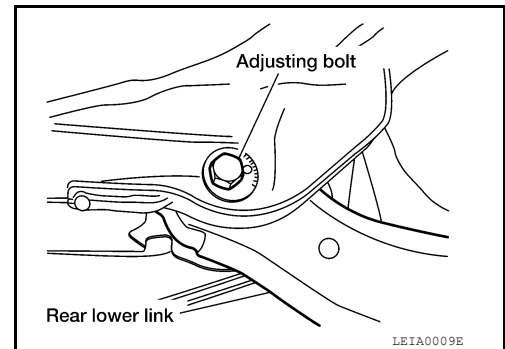

5. Remove the rear lower link pinch bolt and nut from the knuckle using power tool.
6. Slowly lower the rear lower link using the suitable jack to release the coil spring tension. Then remove the upper rubber seat, coil spring and lower rubber seat from the rear lower link.
7. Remove the rear lower link adjusting bolt and nut from the rear suspension member using power tool, then remove the rear lower link.

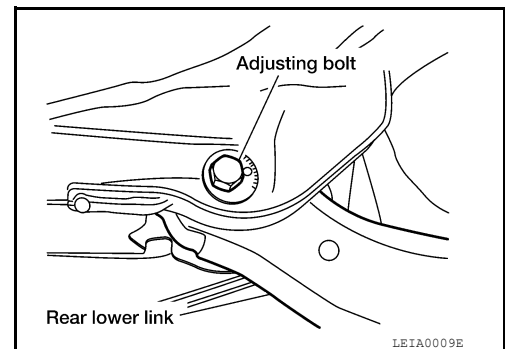

INSPECTION AFTER REMOVAL

Check for deformation, cracks, or other damage and replace if necessary.

INSTALLATION

Installation is in the reverse order of removal.

REAR LOWER LINK & COIL SPRING

< REMOVAL AND INSTALLATION >

- When installing the upper and lower rubber seats for the rear coil springs, the arrow embossed on the rubber seats must point out toward the wheel and tire assembly.
- Perform the final tightening of the rear lower link nuts and bolts (with rubber bushings) under unladen conditions with tires on level ground.
- Tighten the nuts and bolts to specification. Refer to [RSU-10. "Component"](#).
- Check the wheel alignment. Refer to [RSU-6. "Wheel Alignment Inspection"](#).

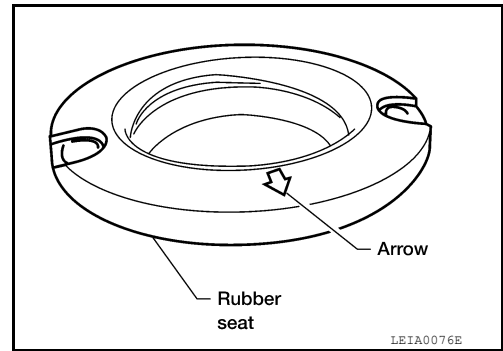

A
B
C
D

RSU

F
G
H
I
J
K
L
M
N
O
P

STABILIZER BAR

< REMOVAL AND INSTALLATION >

STABILIZER BAR

Removal and Installation

INFOID:00000006245814

REMOVAL

1. Disconnect the stabilizer bar ends from the connecting rods using power tool.

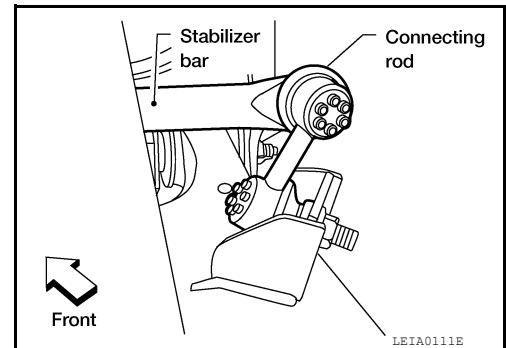

2. Remove the stabilizer bar clamps using power tool, and remove the stabilizer bar bushings.
3. Remove the stabilizer bar.

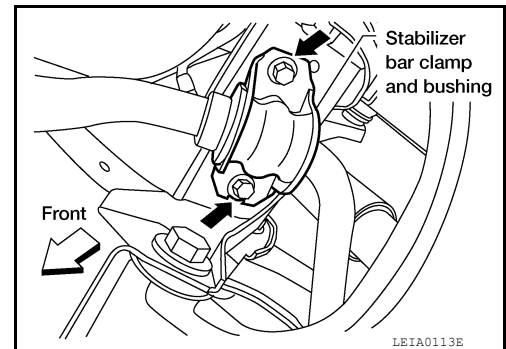

INSPECTION AFTER REMOVAL

- Check stabilizer bar for any deformation, cracks, or damage and replace if necessary.
- Check rubber bushings for deterioration, or cracks and replace if necessary.

INSTALLATION

Installation is in the reverse order of removal.

- Install the stabilizer bar bushings and clamps so they are positioned outside of the sideslip prevention clamp on the stabilizer bar.
- Tighten the nuts and bolts to specification. Refer to [RSU-10, "Component"](#).

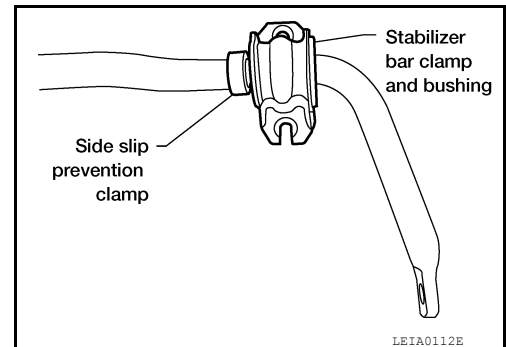

REAR SUSPENSION MEMBER

< UNIT REMOVAL AND INSTALLATION >

UNIT REMOVAL AND INSTALLATION

REAR SUSPENSION MEMBER

Removal and Installation

INFOID:000000006245815

COMPONENTS

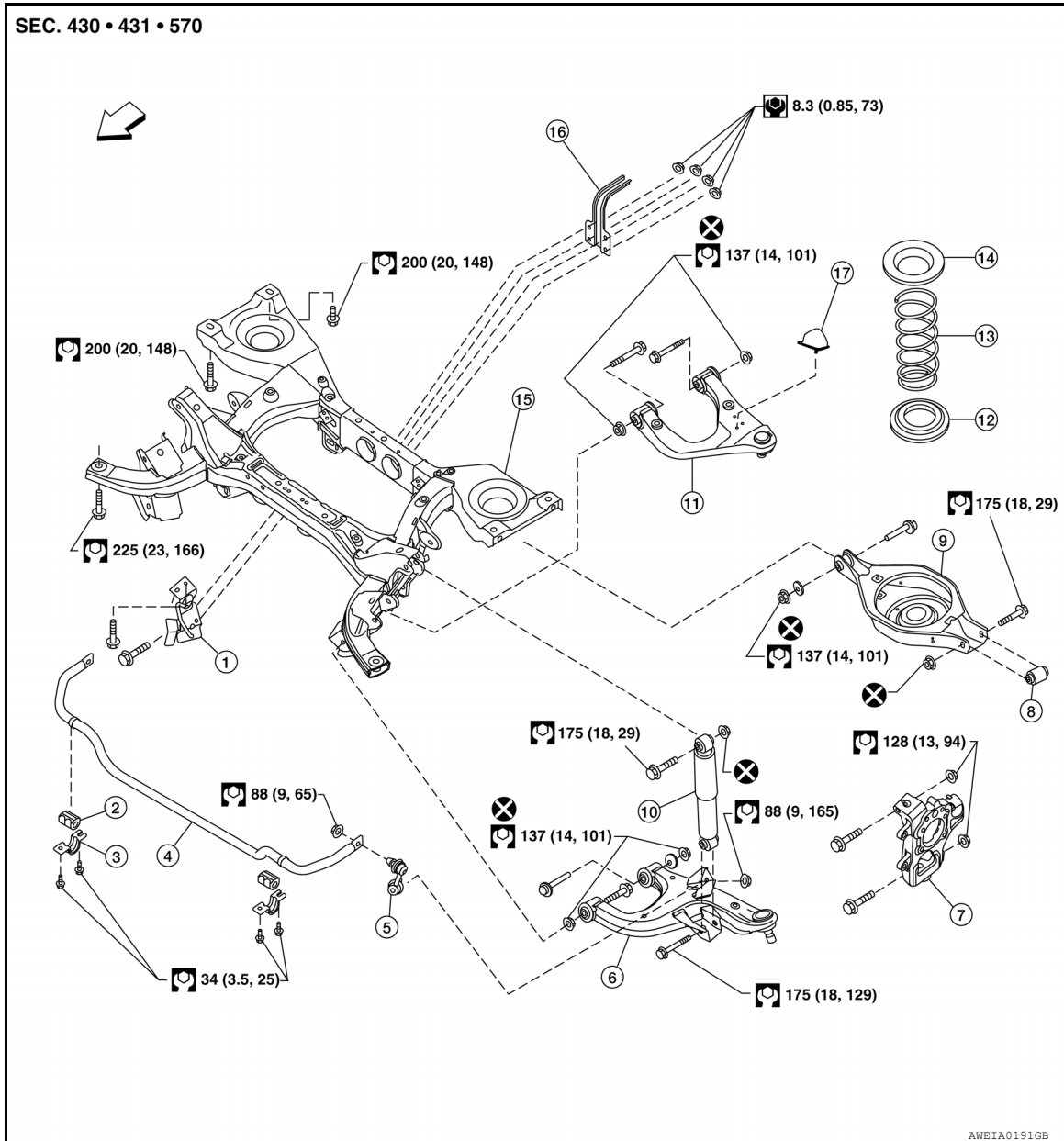

- | | | |
|---------------------------|---------------------------|----------------------------|
| 1. Seat belt latch anchor | 2. Stabilizer bar bushing | 3. Stabilizer bar clamp |
| 4. Stabilizer bar | 5. Connecting rod | 6. Front lower link |
| 7. Knuckle | 8. Bushing | 9. Rear lower link |
| 10. Shock absorber | 11. Suspension arm | 12. Lower rubber seat |
| 13. Coil spring | 14. Upper rubber seat | 15. Rear suspension member |
| 16. Spare tire bracket | 17. Bound bumper | |

REMOVAL

1. Remove both rear wheel and tire assemblies. Refer to [WT-50. "Adjustment"](#).
2. Remove the spare tire.

REAR SUSPENSION MEMBER

< UNIT REMOVAL AND INSTALLATION >

3. Remove the brake caliper without disconnecting the brake hoses, using power tool. Reposition the brake caliper out of the way using a suitable wire. Refer to [BR-48, "Removal and Installation of Brake Caliper and Disc Rotor"](#).

CAUTION:

- Do not crimp or stretch the brake hose when repositioning the brake caliper out of the way.
- Do not press the brake pedal while the brake caliper is positioned out of the way.

4. Remove the two rear brake rotors.
5. Remove the two rear drive shafts. Refer to [RAX-8, "Removal and Installation"](#).
6. Disconnect the parking brake cables brackets from the rear suspension member.
7. Disconnect the two rear wheel sensor connectors and harness clips.
8. Remove the rear final drive vent tube from the rear suspension member and frame.
9. Remove the rear final drive. Refer to [DLN-425, "Removal and Installation"](#) (R200), [DLN-463, "Removal and Installation"](#) (R230).
10. Set a suitable jack to support each of the rear lower links and the coil spring tension.
11. Remove both of the rear lower link outer bolts using power tool, and lower the jack to remove the rear coil springs, and the upper and lower rubber seats.

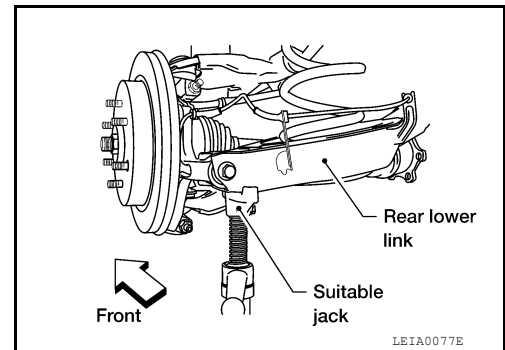

12. Remove the two bolts to disconnect the seat belt latch anchor from the rear suspension member using power tool.

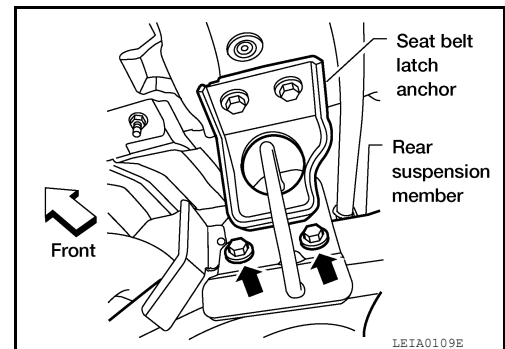

13. Disconnect both of the connecting rods from the rear stabilizer bar.

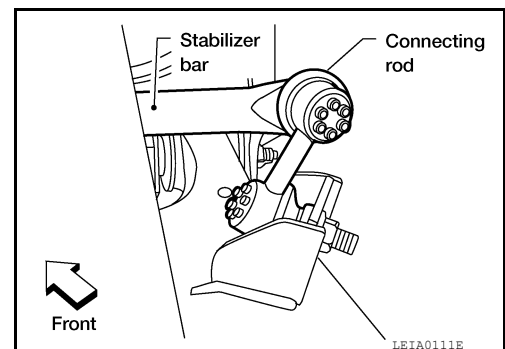

REAR SUSPENSION MEMBER

< UNIT REMOVAL AND INSTALLATION >

14. Set a suitable jack under each front lower link for support and remove the shock absorber upper end bolts and lower end bolts using power tool.
15. Remove both of the shock absorbers.

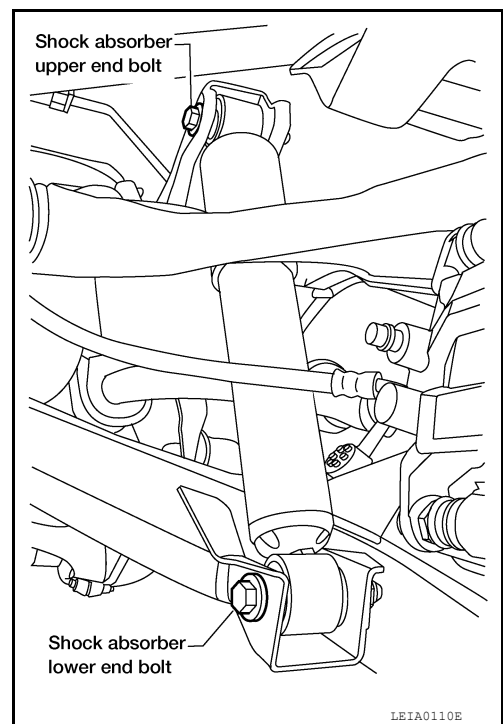

16. Set a suitable jack under the rear suspension member.
17. Remove the six rear suspension member bolts using power tool.
18. Slowly lower the jack supporting the rear suspension member to access the fuel filler tube bracket, then remove the two bolts to disconnect the fuel filler tube bracket from the rear suspension member.

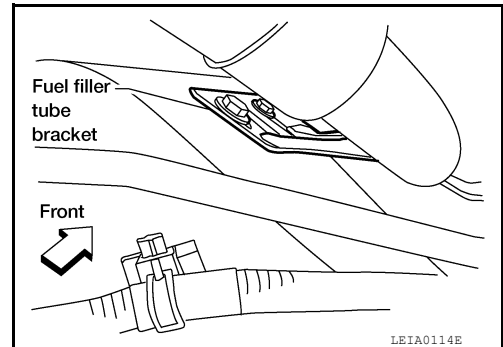

19. Slowly lower the jack to remove the rear suspension member, suspension arm, front and rear lower links, knuckles, and stabilizer bar as an assembly.
20. Remove the suspension arm, spare tire bracket, stabilizer bar, front and rear lower links, and the knuckles from the rear suspension member using power tool.

INSPECTION AFTER REMOVAL

Check rear suspension member for deformation, cracks, and other damage and replace if necessary.

INSTALLATION

Installation is in the reverse order of removal.

- When raising the rear suspension member assembly, use the locating pins to align the rear suspension member to the vehicle body.

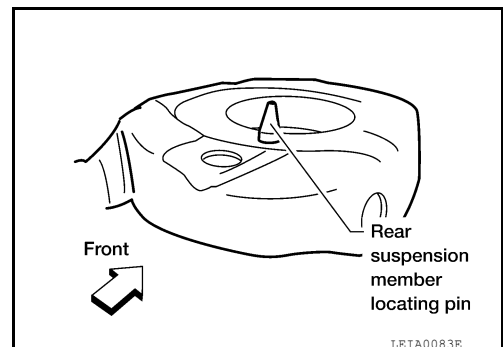

A
B
C
D
RSU
F
G
H
I
J
K
L
M
N
O
P

REAR SUSPENSION MEMBER

< UNIT REMOVAL AND INSTALLATION >

- When installing the upper and lower rubber seats for the rear coil springs, the arrow embossed on the rubber seats must point out toward the wheel and tire assembly.

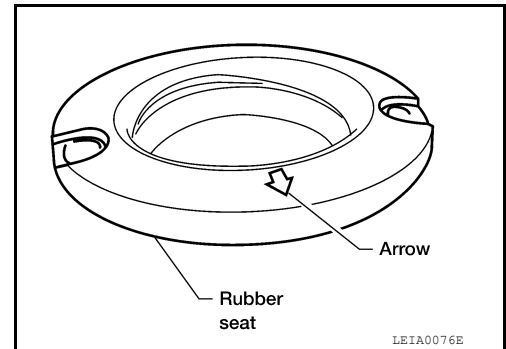

- Perform final tightening of the nuts and bolts for the links (with rubber bushings) under unladen conditions with the tires on level ground.
- Adjust the parking brake cables. Refer to [PB-5. "On-Vehicle Service"](#).
- Check the wheel alignment. Refer to [FSU-7. "Front Wheel Alignment"](#).

SERVICE DATA AND SPECIFICATIONS (SDS)

< SERVICE DATA AND SPECIFICATIONS (SDS)

SERVICE DATA AND SPECIFICATIONS (SDS)

SERVICE DATA AND SPECIFICATIONS (SDS)

Wheel Alignment (Unladen*)

INFOID:000000006245816

Camber Degree minute (decimal degree)	Minimum	- 0° 32' (- 0.53°)
	Nominal	- 0° 2' (- 0.03°)
	Maximum	0° 28' (0.47°)

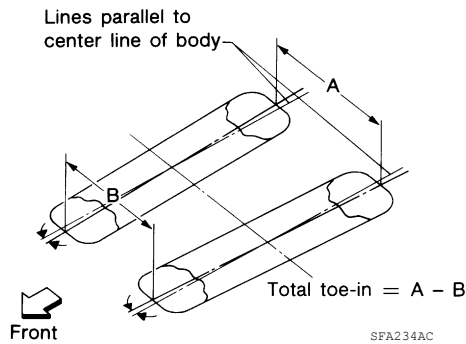

Total toe-in	Distance (A - B)	Minimum	Out 1.4 mm (0.05 in)
		Nominal	In 1.9 mm (0.07 in)
		Maximum	In 5.2 mm (0.20 in)
	Angle Degree minute (decimal degree)	Minimum	Out 0° 3' 36" (0.06°)
		Nominal	In 0° 8' 24" (0.14°)
		Maximum	In 0° 20' 24" (0.34°)

*1: Fuel, radiator coolant and engine oil full. Spare tire, jack, hand tools and mats in designed positions.

Ball Joint

INFOID:000000006245817

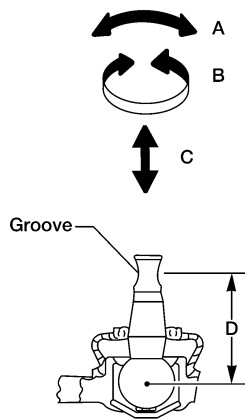

WEIA0131E

Ball joint position	Upper	Lower
---------------------	-------	-------

SERVICE DATA AND SPECIFICATIONS (SDS)

< SERVICE DATA AND SPECIFICATIONS (SDS)

Swinging force* (A)	11.4 - 145.5 N (1.16 - 14.8 kg, 2.56 - 32.7 lb)	11.0 - 140.7 N (1.12 - 14.35 kg, 2.47 - 31.63 lb)
Turning torque (B)	0.5 - 6.4 N·m (0.06 - 0.65 kg·m, 5 - 56 in-lb)	0.5 - 6.4 N·m (0.06 - 0.65 kg·m, 5 - 56 in-lb)
Vertical end play (C)	0 mm (0 in)	0 mm (0 in)
Height (D)	44 mm (1.73 in)	45.5 mm (1.79 in)

*: Measurement point is at the bolt groove of the ball stud.

Wheelarch Height (Unladen*)

INFOID:000000006245818

Unit: mm (in)

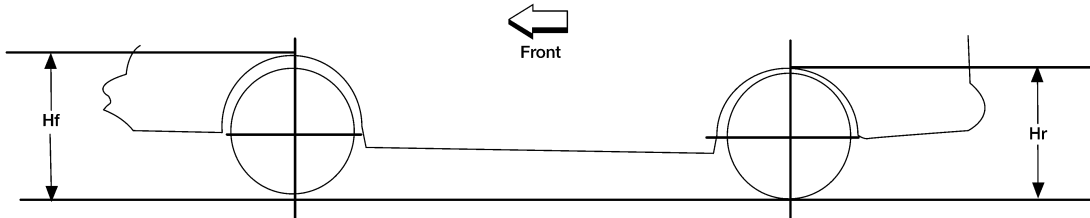

LEIA0085E

Engine	VQ40DE						VK56DE
Drive type	2WD			4WD			4WD
Tire size	P245/75R16	P265/65R17	P265/60R18	P245/75R16	P265/65R17	P265/60R18	P265/60R18
Front wheelarch height (Hf)	867 (34.13)	865 (34.06)	867 (34.13)	875 (34.45)	874 (34.41)	891 (35.08)	876 (34.49)
Rear wheelarch height (Hr)	875 (34.45)	873 (34.37)	875 (34.45)	884 (34.80)	883 (34.76)	901 (35.47)	886 (34.88)

*1: Fuel, radiator coolant and engine oil full. Spare tire, jack, hand tools and mats in designated positions.