

**SECTION BR**  
**BRAKE SYSTEM**

A  
B  
C  
D  
E

**CONTENTS**

<b>PRECAUTION</b> .....	3	Inspection .....	11	<b>BR</b>
<b>PRECAUTIONS</b> .....	3	<b>BRAKE MASTER CYLINDER</b> .....	12	
Precaution for Supplemental Restraint System (SRS) "AIR BAG" and "SEAT BELT PRE-TENSIONER" .....	3	On Board Inspection .....	12	G
Precaution Necessary for Steering Wheel Rotation After Battery Disconnect .....	3	<b>BRAKE TUBE AND HOSE</b> .....	13	
Precaution for Brake System .....	4	Hydraulic Circuit .....	13	H
<b>PREPARATION</b> .....	5	<b>FRONT BRAKE</b> .....	15	
<b>PREPARATION</b> .....	5	FRONT BRAKE : Inspection .....	15	I
Special Service Tool .....	5	<b>REAR BRAKE</b> .....	16	
Commercial Service Tool .....	5	REAR BRAKE : Inspection .....	16	J
<b>SYSTEM DESCRIPTION</b> .....	6	<b>PERIODIC MAINTENANCE</b> .....	17	
<b>NOISE, VIBRATION, AND HARSHNESS (NVH) TROUBLESHOOTING</b> .....	6	<b>BRAKE PEDAL</b> .....	17	K
NVH Troubleshooting Chart .....	6	Inspection and Adjustment - Standard Pedal .....	17	
<b>BASIC INSPECTION</b> .....	7	Inspection and Adjustment - Adjustable Pedal .....	18	L
<b>FRONT DISC BRAKE</b> .....	7	<b>BRAKE FLUID</b> .....	20	
<b>BRAKE PAD</b> .....	7	On Board Inspection .....	20	M
BRAKE PAD : Inspection .....	7	Drain and Refill .....	20	
<b>DISC ROTOR</b> .....	7	Bleeding Brake System .....	20	N
DISC ROTOR : Inspection .....	7	<b>REMOVAL AND INSTALLATION</b> .....	22	
<b>REAR DISC BRAKE</b> .....	9	<b>BRAKE PEDAL</b> .....	22	O
<b>BRAKE PAD</b> .....	9	Exploded View .....	22	
BRAKE PAD : Inspection .....	9	Removal and Installation .....	23	P
<b>DISC ROTOR</b> .....	9	<b>BRAKE TUBE AND HOSE</b> .....	26	
DISC ROTOR : Inspection .....	9	Hydraulic Circuit .....	26	
<b>BRAKE BOOSTER</b> .....	10	Removal and Installation of Front Brake Piping and Brake Hose .....	28	
Inspection .....	10	Removal and Installation of Rear Brake Piping and Brake Hose .....	29	
<b>VACUUM LINES</b> .....	11	Inspection After Installation .....	30	
		<b>BRAKE MASTER CYLINDER</b> .....	32	
		Removal and Installation .....	32	
		<b>BRAKE BOOSTER</b> .....	35	

Removal and Installation .....	35	<b>BRAKE MASTER CYLINDER .....</b>	<b>50</b>
<b>VACUUM LINES .....</b>	<b>38</b>	Disassembly and Assembly .....	50
Removal and Installation .....	38	<b>FRONT DISC BRAKE .....</b>	<b>53</b>
<b>FRONT DISC BRAKE .....</b>	<b>39</b>	Exploded View of Brake Caliper .....	53
Exploded View of Brake Pads .....	39	Disassembly and Assembly .....	53
Removal and Installation of Brake Pad .....	40	<b>REAR DISC BRAKE .....</b>	<b>56</b>
Brake Burnishing .....	41	Exploded View of Brake Caliper .....	56
Exploded View of Brake Caliper .....	42	Disassembly and Assembly .....	56
Removal and Installation of Brake Caliper and Disc Rotor .....	42	<b>SERVICE DATA AND SPECIFICATIONS (SDS) .....</b>	<b>59</b>
<b>REAR DISC BRAKE .....</b>	<b>45</b>	<b>SERVICE DATA AND SPECIFICATIONS (SDS) .....</b>	<b>59</b>
Exploded View of Brake Pad .....	45	General Specification .....	59
Removal and Installation of Brake Pad .....	45	Brake Pedal .....	59
Brake Burnishing .....	46	Brake Booster .....	60
Exploded View of Brake Caliper .....	47	Check Valve .....	60
Removal and Installation of Brake Caliper and Disc Rotor .....	47	Front Disc Brake .....	61
<b>UNIT DISASSEMBLY AND ASSEMBLY ...</b>	<b>50</b>	Rear Disc Brake .....	61

# PRECAUTIONS

< PRECAUTION >

## PRECAUTION

### PRECAUTIONS

#### Precaution for Supplemental Restraint System (SRS) "AIR BAG" and "SEAT BELT PRE-TENSIONER"

INFOID:000000007356596

The Supplemental Restraint System such as "AIR BAG" and "SEAT BELT PRE-TENSIONER", used along with a front seat belt, helps to reduce the risk or severity of injury to the driver and front passenger for certain types of collision. This system includes seat belt switch inputs and dual stage front air bag modules. The SRS system uses the seat belt switches to determine the front air bag deployment, and may only deploy one front air bag, depending on the severity of a collision and whether the front occupants are belted or unbelted. Information necessary to service the system safely is included in the SR and SB section of this Service Manual.

#### **WARNING:**

- To avoid rendering the SRS inoperative, which could increase the risk of personal injury or death in the event of a collision which would result in air bag inflation, all maintenance must be performed by an authorized NISSAN/INFINITI dealer.
- Improper maintenance, including incorrect removal and installation of the SRS, can lead to personal injury caused by unintentional activation of the system. For removal of Spiral Cable and Air Bag Module, see the SR section.
- Do not use electrical test equipment on any circuit related to the SRS unless instructed to in this Service Manual. SRS wiring harnesses can be identified by yellow and/or orange harnesses or harness connectors.

#### PRECAUTIONS WHEN USING POWER TOOLS (AIR OR ELECTRIC) AND HAMMERS

#### **WARNING:**

- When working near the Airbag Diagnosis Sensor Unit or other Airbag System sensors with the Ignition ON or engine running, DO NOT use air or electric power tools or strike near the sensor(s) with a hammer. Heavy vibration could activate the sensor(s) and deploy the air bag(s), possibly causing serious injury.
- When using air or electric power tools or hammers, always switch the Ignition OFF, disconnect the battery, and wait at least 3 minutes before performing any service.

#### Precaution Necessary for Steering Wheel Rotation After Battery Disconnect

INFOID:000000007356597

#### **NOTE:**

- This Procedure is applied only to models with Intelligent Key system and NATS (NISSAN ANTI-THEFT SYSTEM).
- Remove and install all control units after disconnecting both battery cables with the ignition knob in the "LOCK" position.
- Always use CONSULT to perform self-diagnosis as a part of each function inspection after finishing work. If DTC is detected, perform trouble diagnosis according to self-diagnostic results.

For models equipped with the Intelligent Key system and NATS, an electrically controlled steering lock mechanism is adopted on the key cylinder.

For this reason, if the battery is disconnected or if the battery is discharged, the steering wheel will lock and steering wheel rotation will become impossible.

If steering wheel rotation is required when battery power is interrupted, follow the procedure below before starting the repair operation.

#### OPERATION PROCEDURE

1. Connect both battery cables.

#### **NOTE:**

Supply power using jumper cables if battery is discharged.

2. Use the Intelligent Key or mechanical key to turn the ignition switch to the "ACC" position. At this time, the steering lock will be released.
3. Disconnect both battery cables. The steering lock will remain released and the steering wheel can be rotated.
4. Perform the necessary repair operation.

# PRECAUTIONS

## < PRECAUTION >

5. When the repair work is completed, return the ignition switch to the "LOCK" position before connecting the battery cables. (At this time, the steering lock mechanism will engage.)
6. Perform a self-diagnosis check of all control units using CONSULT.

## Precaution for Brake System

INFOID:000000007356598

- Recommended fluid is Genuine NISSAN Super Heavy Duty Brake Fluid or equivalent. Refer to [MA-18. "FOR USA AND CANADA : Fluids and Lubricants"](#) (United States and Canada), [MA-20. "FOR MEXICO : Fluids and Lubricants"](#) (Mexico).
- Do not reuse drained brake fluid.
- Be careful not to splash brake fluid on painted areas.
- To clean or wash all parts of master cylinder, disc brake caliper and wheel cylinder, use clean brake fluid.
- Do not use mineral oils such as gasoline or kerosene. They will ruin rubber parts of the hydraulic system.
- Use flare nut wrench when removing and installing brake tube.
- Always check tightening torque when installing brake lines.
- Before working, turn ignition switch to OFF and disconnect connectors for ABS actuator and electric unit (control unit) or battery negative terminal.
- Burnish the brake contact surfaces after refinishing or replacing drums or rotors, after replacing pads or linings, or if a soft pedal occurs at very low mileage.  
Refer to [BR-41. "Brake Burnishing"](#).

### **WARNING:**

- Clean dust on caliper and brake pads with a vacuum dust collector to minimize the hazard of airborne particles or other materials.

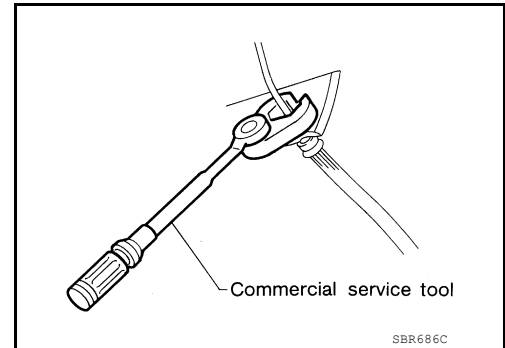

# PREPARATION

< PREPARATION >

## PREPARATION

### PREPARATION

#### Special Service Tool

INFOID:000000007356600

The actual shapes of Kent-Moore tools may differ from those of special service tools illustrated here.

Tool number (Kent-Moore No.) Tool name	Description
— (J-46532) Brake and clutch pedal height measurement tool	Measuring brake pedal height
38-PFM90.5 ( — ) Pro-Cut PFM 90 On-Car Brake Lathe	Turning rotors

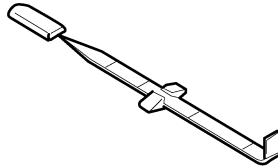

LF1A0227E

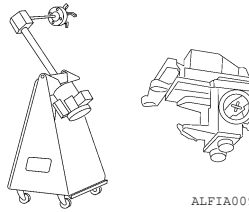

ALF1A00922Z

#### Commercial Service Tool

INFOID:000000007356601

Tool name	Description
1. Flare nut crowfoot 2. Torque wrench	Removing and installing brake piping <b>a: 10 mm (0.39 in) / 12 mm (0.47 in)</b>
Power tool	Loosening nuts, screws and bolts

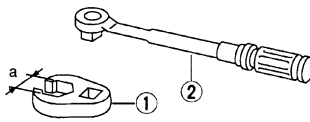

S-NT360



PIIB1407E



# FRONT DISC BRAKE

< BASIC INSPECTION >

## BASIC INSPECTION

### FRONT DISC BRAKE

#### BRAKE PAD

#### BRAKE PAD : Inspection

INFOID:000000007356603

#### PAD WEAR

Check pad thickness from the inspection holes on cylinder body.  
Check using a scale if necessary.

**Standard thickness (new)** : Refer to [BR-61, "Front Disc Brake"](#).

**Repair limit thickness** : Refer to [BR-61, "Front Disc Brake"](#).

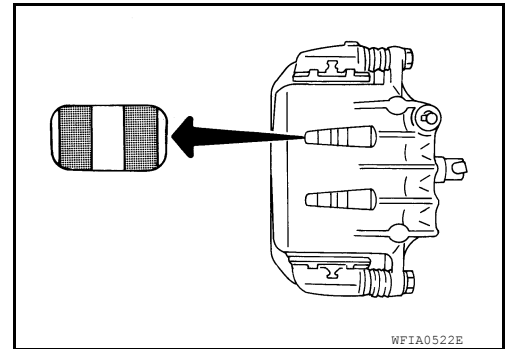

#### DISC ROTOR

#### DISC ROTOR : Inspection

INFOID:000000007356604

#### VISUAL

Check surface of disc rotor for uneven wear, cracks, and serious damage. Replace as necessary.

#### RUNOUT

1. Attach disc rotor to wheel hub using wheel nuts at two or more positions.
2. Inspect runout using a dial gauge placed at 10 mm (0.39 in) inside the disc edge.

**Runout limit** : Refer to [BR-61, "Front Disc Brake"](#).

**(with it attached to the vehicle)**

#### NOTE:

Before measuring, make sure that wheel bearing axial end play is within the specification. Refer to [FAX-6, "On-Vehicle Inspection and Service"](#).

3. When runout exceeds limit value, displace mounting positions of disc rotor by one hole. And then find a position of the minimum value for runout.
4. If runout is outside the specified value after performing the above operation, turn disc rotor using Tool.

**Tool number** : 38-PFM90.5 ( — )

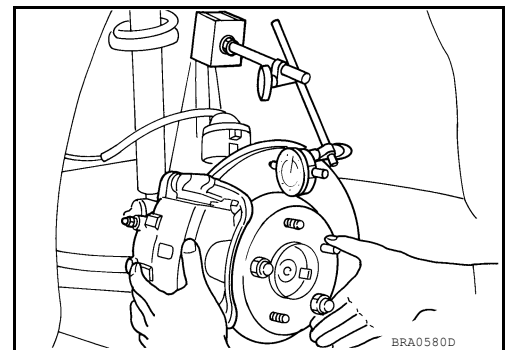

#### THICKNESS

## FRONT DISC BRAKE

### < BASIC INSPECTION >

Check thickness of the disc rotor using a micrometer. Replace disc rotor if thickness is less than the repair limit thickness.

- Standard thickness (new)** : Refer to [BR-61, "Front Disc Brake"](#).
- Repair limit thickness** : Refer to [BR-61, "Front Disc Brake"](#).
- Maximum uneven wear (measured at 8 positions)** : Refer to [BR-61, "Front Disc Brake"](#).

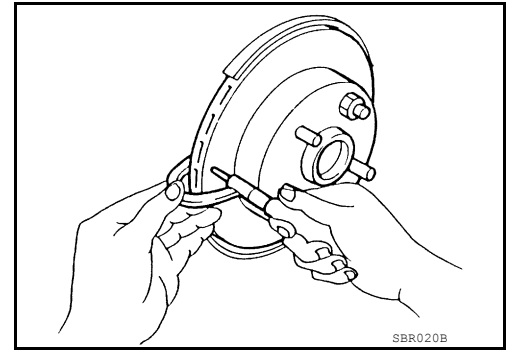



# REAR DISC BRAKE

< BASIC INSPECTION >

## REAR DISC BRAKE

### BRAKE PAD

#### BRAKE PAD : Inspection

INFOID:000000007356605

#### PAD WEAR

Check pad thickness from an inspection hole on cylinder body.  
Check using a scale if necessary.

**Standard thickness (new)** : Refer to [BR-61, "Rear Disc Brake"](#).

**Repair limit thickness** : Refer to [BR-61, "Rear Disc Brake"](#).

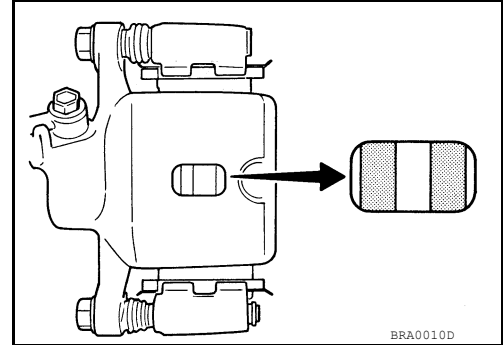

### DISC ROTOR

#### DISC ROTOR : Inspection

INFOID:000000007356606

#### VISUAL

Check surface of disc rotor for uneven wear, cracks, and serious damage. Replace as necessary.

#### RUNOUT

1. Attach disc rotor to wheel hub using wheel nuts at two or more positions.
2. Inspect runout using dial gauge placed at 10 mm (0.39 in) inside disc edge.

**Runout limit** : Refer to [BR-61, "Rear Disc Brake"](#).  
(with it attached to the vehicle)

#### NOTE:

Before measuring, make sure that wheel bearing axial end play is within the specification. Refer to [RAX-6, "On-Vehicle Inspection and Service"](#).

3. When runout exceeds limit value, displace mounting positions of disc rotor by one hole. And then find a position of the minimum value for runout.
4. If runout is outside the specified value after performing the above operation, turn disc rotor using Tool.

**Tool number** : 38-PFM90.5 ( — )

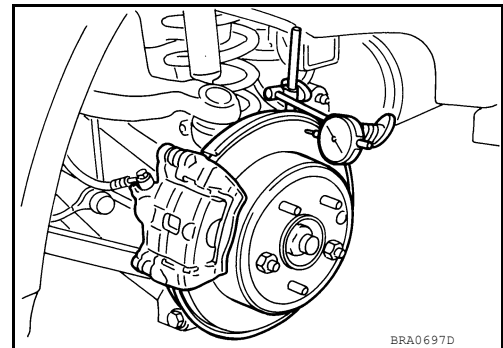

#### THICKNESS

Check the thickness of the disc rotor using a micrometer. Replace disc rotor if the thickness is less than the repair limit thickness.

**Standard thickness (new)** : Refer to [BR-61, "Rear Disc Brake"](#).

**Repair limit thickness** : Refer to [BR-61, "Rear Disc Brake"](#).

**Maximum uneven wear (measured at 8 positions)** : Refer to [BR-61, "Rear Disc Brake"](#).

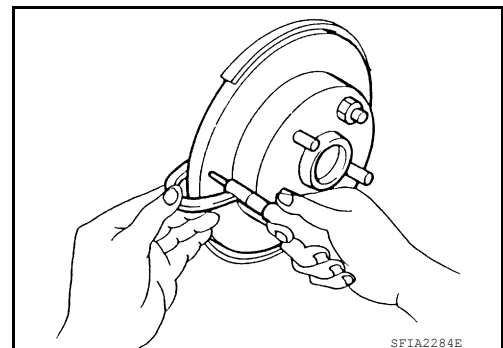

# BRAKE BOOSTER

< BASIC INSPECTION >

## BRAKE BOOSTER

### Inspection

INFOID:000000007356607

### OPERATION

With engine stopped, change vacuum to atmospheric pressure by depressing brake pedal several times. Then with brake pedal fully depressed, start engine and when vacuum pressure reaches the standard, make sure that clearance between brake pedal and floor panel decreases.

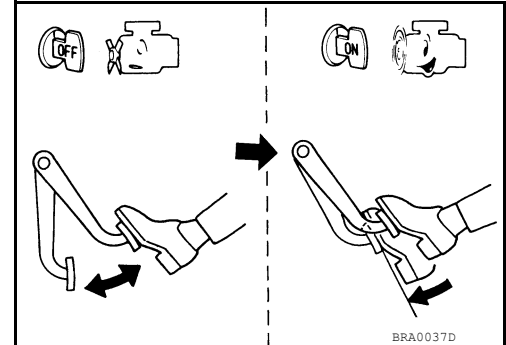

### AIR TIGHT

- Run engine at idle for approximately 1 minute, and stop it after applying vacuum to booster. Depress brake pedal normally to change vacuum to atmospheric pressure. Make sure that distance at intervals of 5 seconds between brake pedal and floor panel gradually increases.

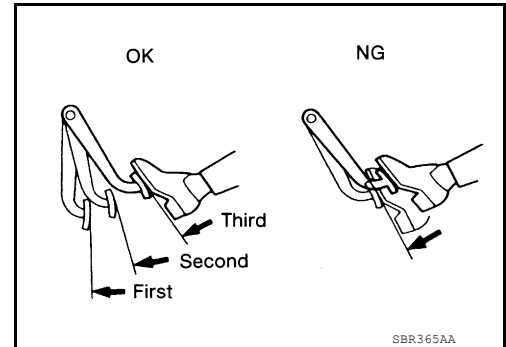

- Depress brake pedal while engine is running, and stop engine with pedal depressed. The pedal stroke should not change after holding pedal down for 30 seconds.

# VACUUM LINES

< BASIC INSPECTION >

## VACUUM LINES

### Inspection

INFOID:000000007356608

#### VISUAL INSPECTION

Check for improper assembly, damage and deterioration. Replace as necessary.

#### CHECK VALVE INSPECTION

##### Airtightness Inspection

Use a suitable tool to check vacuum check valve. Connect to brake booster side of check valve.

**Check valve specification** : Refer to [BR-60, "Check Valve"](#).

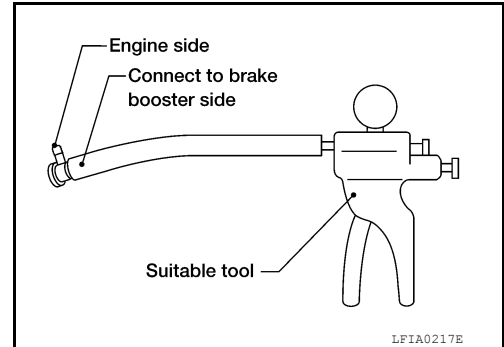

A  
B  
C  
D  
E  
BR  
G  
H  
I  
J  
K  
L  
M  
N  
O  
P

# BRAKE MASTER CYLINDER

< BASIC INSPECTION >

---

## BRAKE MASTER CYLINDER

### On Board Inspection

*INFOID:000000007356609*

#### LEAK INSPECTION

Check for leaks at master cylinder to brake booster attachment point, reservoir tank, and brake tube connections.



# BRAKE TUBE AND HOSE

< BASIC INSPECTION >

## ABS Actuator and Electric Unit Brake Pipe Connections for VQ40DE

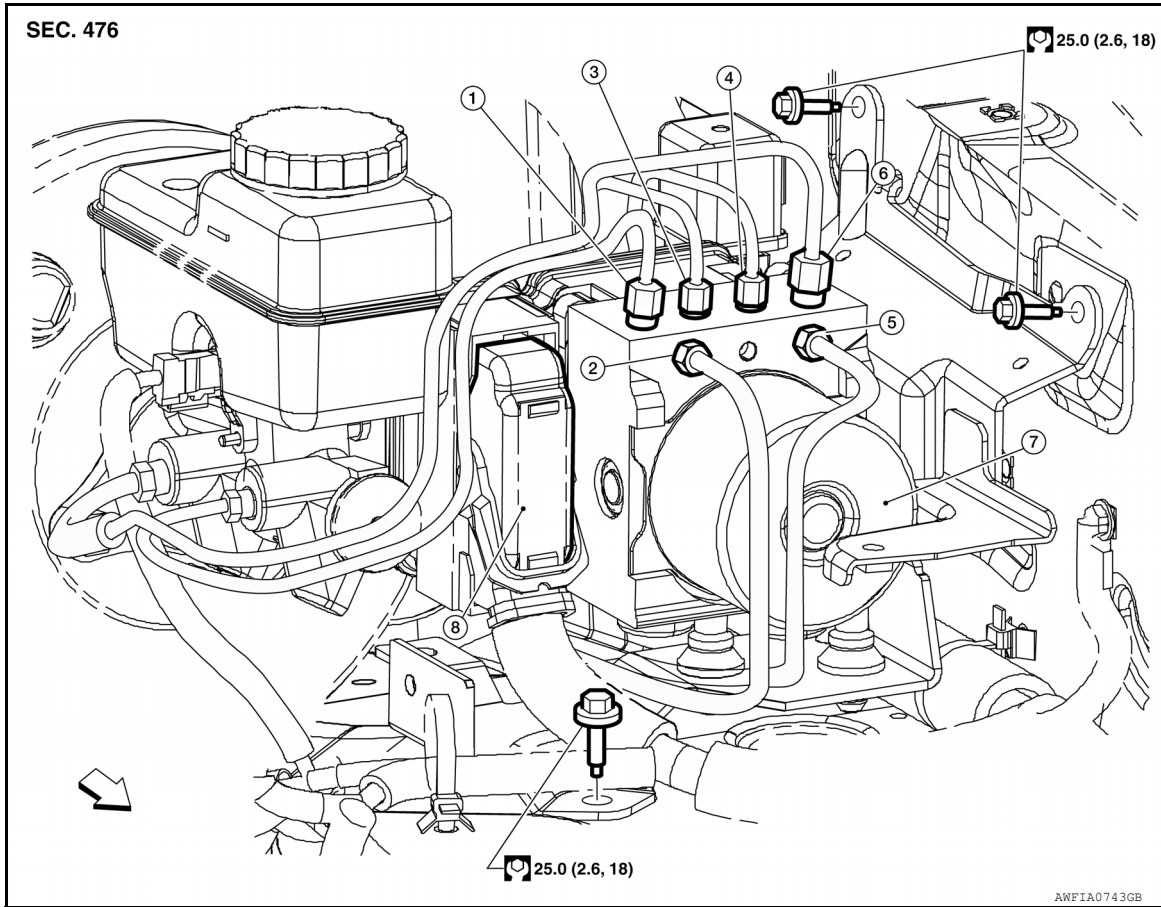

- |   |  |   |
|---|--|---|
| 1. From the master cylinder secondary side<br>18.2 N·m (1.9 kg-m, 13 ft-lb) | 2. To rear right disc brake<br>13.0 N·m (1.3 kg-m, 10 ft-lb) | 3. To rear left disc brake<br>13.0 N·m (1.3 kg-m, 10 ft-lb)               |
| 4. To front right disc brake<br>13.0 N·m (1.3 kg-m, 10 ft-lb)               | 5. To front left disc brake<br>13.0 N·m (1.3 kg-m, 10 ft-lb) | 6. From the master cylinder primary side<br>18.2 N·m (1.9 kg-m, 13 ft-lb) |
| 7. ABS actuator and electric unit (control unit)                            | 8. Harness connector   | ⇐ Front   |

# BRAKE TUBE AND HOSE

< BASIC INSPECTION >

## ABS Actuator and Electric Unit Brake Pipe Connections for VK56DE

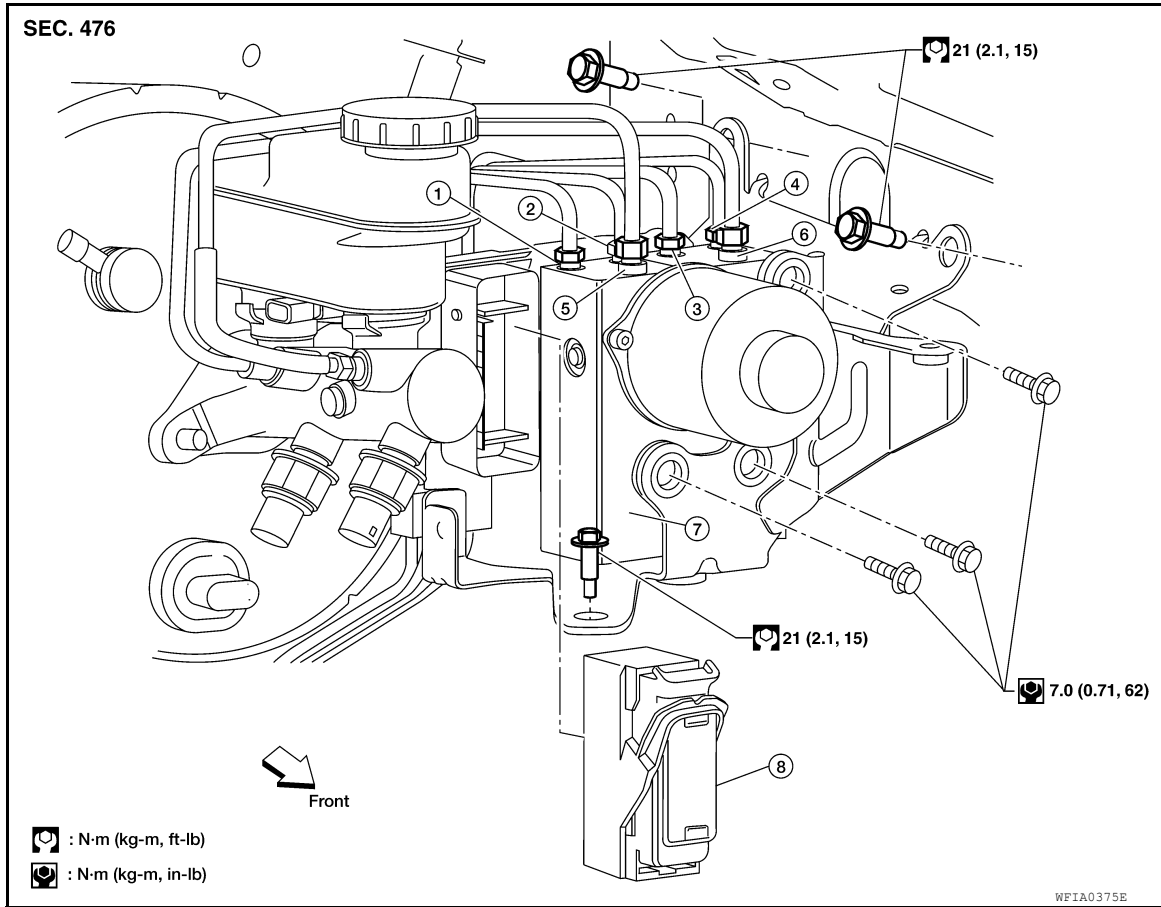

- |   |   |   |
|---|---|---|
| 1. To rear left disc brake<br>13.0 N·m (1.3 kg-m, 10 ft-lb)   | 2. To rear right disc brake<br>13.0 N·m (1.3 kg-m, 10 ft-lb)                | 3. To front left disc brake<br>13.0 N·m (1.3 kg-m, 10 ft-lb)              |
| 4. To front right disc brake<br>13.0 N·m (1.3 kg-m, 10 ft-lb) | 5. From the master cylinder secondary side<br>18.2 N·m (1.9 kg-m, 13 ft-lb) | 6. From the master cylinder primary side<br>18.2 N·m (1.9 kg-m, 13 ft-lb) |
| 7. ABS actuator and electric unit<br>(control unit)           | 8. Harness connector  |   |

### CAUTION:

- All hoses and piping (tubes) must be free from excessive bending, twisting and pulling.
- Make sure there is no interference with other parts when turning the steering wheel both clockwise and counterclockwise.
- The brake piping is an important safety part. If a brake fluid leak is detected, always disassemble the parts. Replace applicable part with a new one, if necessary.
- Be careful not to splash brake fluid on painted areas; it may cause paint damage. If brake fluid is splashed on painted areas, wash it away with water immediately.
- Do not bend or twist brake hose sharply, or strongly pull it.
- When removing components, cover connections so that no dirt, dust, or other foreign matter gets in.
- Refill with new specified brake fluid. Refer to [MA-18, "FOR USA AND CANADA : Fluids and Lubricants"](#) (United States and Canada) [MA-20, "FOR MEXICO : Fluids and Lubricants"](#) (Mexico).
- Do not reuse drained brake fluid.

## FRONT BRAKE

### FRONT BRAKE : Inspection

INFOID:000000007356611

### INSPECTION AFTER REMOVAL

#### CAUTION:

Brake tubes and hoses are important safety parts. Always disassemble the parts and retighten their fittings, if a brake fluid leak is detected. Replace applicable part with a new one, if damaged part is detected.

# BRAKE TUBE AND HOSE

## < BASIC INSPECTION >

---

1. Check brake lines (tubes and hoses) and connections for fluid leaks, damage, twists, deformation, contact with other parts, and loose connections. Replace any parts as necessary. Refer to [BR-13, "Hydraulic Circuit"](#).
2. While depressing brake pedal under a force of 785 N (80 kg-f, 177 lb-f) with engine running for approximately 5 seconds, check each part for fluid leaks.

## REAR BRAKE

### REAR BRAKE : Inspection

INFOID:000000007356612

### INSPECTION AFTER REMOVAL

#### **CAUTION:**

**Brake tubes and hoses are important safety parts. Always disassemble the parts and retighten their fittings, if a brake fluid leak is detected. Replace applicable part with a new one, if damaged part is detected.**

1. Check brake lines (tubes and hoses) and connections for fluid leaks, damage, twists, deformation, contact with other parts, and loose connections. Replace any parts as necessary. Refer to [BR-13, "Hydraulic Circuit"](#).
2. While depressing brake pedal under a force of 785 N (80 kg-f, 177 lb-f) with engine running for approximately 5 seconds, check each part for fluid leaks.



# BRAKE PEDAL

< PERIODIC MAINTENANCE >

## PERIODIC MAINTENANCE

### BRAKE PEDAL

#### Inspection and Adjustment - Standard Pedal

INFOID:000000007356613

#### INSPECTION

1. Inspect the brake pedal free height (H) from the floor using Tool at a 90° angle to the floor as shown.

**Tool number** : — (J-46532)

2. Adjust the brake pedal height to specifications.

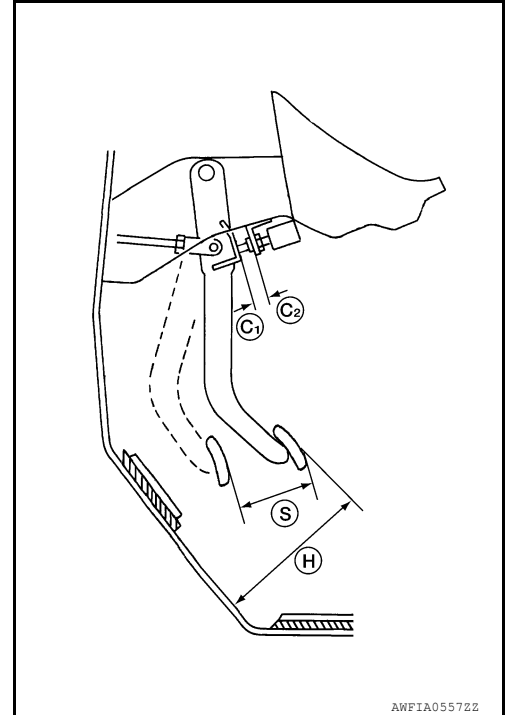

Brake Pedal Specifications

Unit: mm (in)

Pedal free height (H)	Refer to <a href="#">BR-59, "Brake Pedal"</a> .
Pedal full stroke (S)	Refer to <a href="#">BR-59, "Brake Pedal"</a> .
Clearance between brake pedal bracket (C1) and threaded end of stop lamp switch and ASCD cancel switch (C2)	Refer to <a href="#">BR-59, "Brake Pedal"</a> .

#### ADJUSTMENT

1. Loosen the stop lamp switch and ASCD cancel switch by turning 45° counterclockwise.

# BRAKE PEDAL

## < PERIODIC MAINTENANCE >

- Loosen lock nut (A) on the input rod, then turn input rod to adjust the brake pedal to specified height. When finished adjusting, tighten lock nut (A) to specification.

**Lock nut (A) : 18.7 N·m (1.9 kg-m, 14 ft-lb)**

**CAUTION:**

**Make sure that the screw portion of the end of input rod is located inside the clevis.**

- With the brake pedal pulled up and held by hand, press the stop lamp switch and the ASCD cancel switch in until threaded ends contact the brake pedal bracket.
- With the threaded ends of the stop lamp switch and ASCD cancel switch contacting the pedal bracket, turn the switches 45° clockwise to lock in place. Check that the stop lamp switch and ASCD cancel switch threaded end to brake pedal bracket gap (C) is within specifications.

**CAUTION:**

**Make sure that the gap (C) between the brake pedal bracket and stop lamp switch and ASCD cancel switch threaded ends are within specification.**

- Check the brake pedal for smooth operation.

**CAUTION:**

**Make sure that the stop lamp goes off when the brake pedal is released.**

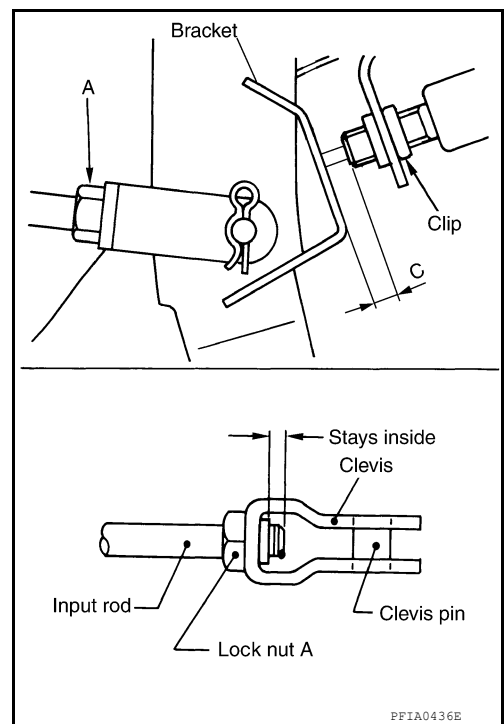

PFIA0436E

## Inspection and Adjustment - Adjustable Pedal

INFOID:000000007356614

### INSPECTION

- Inspect the brake pedal free height (H) from the floor using Tool at a 90° angle to the floor as shown.

**Tool number : — (J-46532)**

- Adjust the height referring to the following specifications.

**CAUTION:**

**When equipped with adjustable pedal, the pedal must be in the forward most (closest to the floor) position for pedal height measurement.**

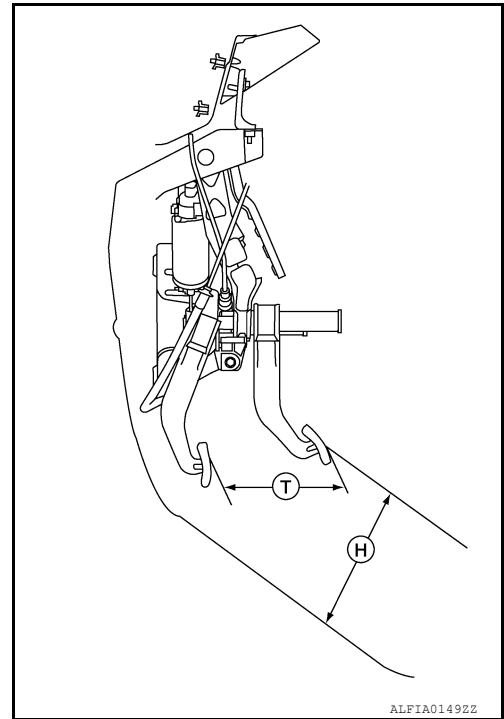

ALFIA01492Z

Brake Pedal Specifications

Unit: mm (in)

Pedal free height (H) with pedal in forward most position	Refer to <a href="#">BR-59, "Brake Pedal"</a> .
---	---

# BRAKE PEDAL

## < PERIODIC MAINTENANCE >

Pedal full stroke (T)	Refer to <a href="#">BR-59, "Brake Pedal"</a> .
Clearance between brake pedal bracket and threaded end of stop lamp switch and ASCD cancel switch	Refer to <a href="#">BR-59, "Brake Pedal"</a> .

**CAUTION:**

When equipped with adjustable pedal, the pedal must be in the forward most position (closest to the floor) for pedal height adjustment.

### ADJUSTMENT

1. Loosen the stop lamp switch and ASCD cancel switch by turning them 45° counterclockwise.
2. Loosen lock nut (A) on the input rod, then turn input rod to adjust the brake pedal to the specified height. When finished adjusting, tighten the lock nut (A) to specification.

**Lock nut (A) : 18.7 N·m (1.9 kg-m, 14 ft-lb)**

**CAUTION:**

Make sure that the screw portion of the end of input rod is located inside the clevis.

3. With the brake pedal pulled up and held by hand, press the stop lamp switch and the ASCD cancel switch in until the threaded ends contact the brake pedal bracket.
4. With the threaded ends of the stop lamp switch and ASCD cancel switch contacting the pedal bracket, turn the switches 45° clockwise to lock in place. Check that the stop lamp switch and ASCD cancel switch threaded end to brake pedal bracket gap (C) is within specifications.

**CAUTION:**

Make sure that the gap (C) between the brake pedal bracket and stop lamp switch and ASCD cancel switch threaded ends are within specification.

5. Check the brake pedal for smooth operation.

**CAUTION:**

Make sure that the stop lamp goes off when the brake pedal is released.

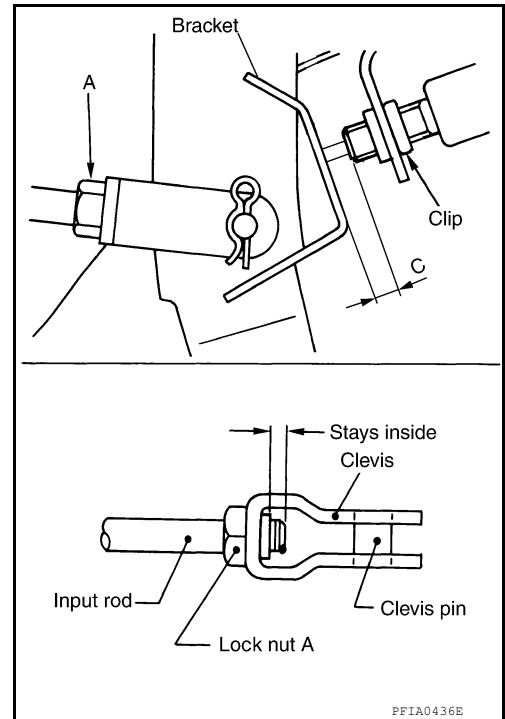

# BRAKE FLUID

< PERIODIC MAINTENANCE >

## BRAKE FLUID

### On Board Inspection

INFOID:000000007356615

#### LEVEL CHECK

- Check that the brake fluid level in the reservoir tank is within specification, between the MAX and MIN lines as shown.
- Visually check around reservoir tank for fluid leaks.
- If fluid level is excessively low, check brake system for leaks.
- If brake warning lamp remains illuminated after the parking brake pedal is released, check the brake system for any brake fluid leaks.

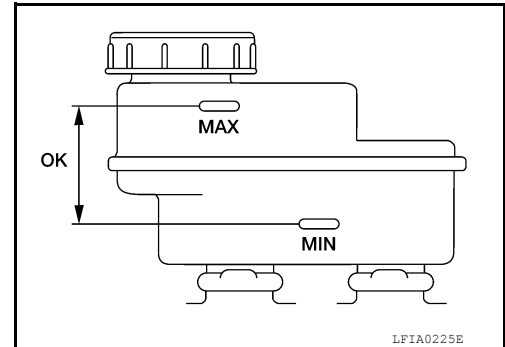

### Drain and Refill

INFOID:000000007356616

#### CAUTION:

- Refill with new brake fluid. Refer to [MA-18, "FOR USA AND CANADA : Fluids and Lubricants"](#) (United States and Canada), [MA-20, "FOR MEXICO : Fluids and Lubricants"](#) (Mexico).
  - Do not reuse drained brake fluid.
  - Be careful not to splash brake fluid on the painted areas; it may cause paint damage. If brake fluid is splashed on painted areas, wash it away with water immediately.
  - Before servicing, disconnect ABS actuator and electric unit (control unit) connector or battery negative terminal.
1. Turn ignition switch OFF and disconnect ABS actuator and electric unit (control unit) connector or battery negative terminal.
  2. Connect a vinyl tube to each bleed valve.
  3. Depress brake pedal, loosen each bleed valve, and gradually remove brake fluid.

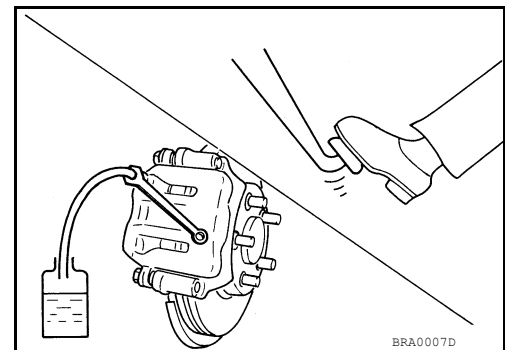

4. Make sure there is no foreign material in reservoir tank, and refill with new brake fluid.
5. Rest foot on brake pedal. Loosen bleed valve. Slowly depress brake pedal until it stops. Tighten bleed valve. Release brake pedal. Repeat the process a few times, then pause to add new brake fluid to master cylinder. Continue until the new brake fluid flows out of the bleed valve. Bleed the air out of the brake hydraulic system. Refer to [BR-20, "Bleeding Brake System"](#).

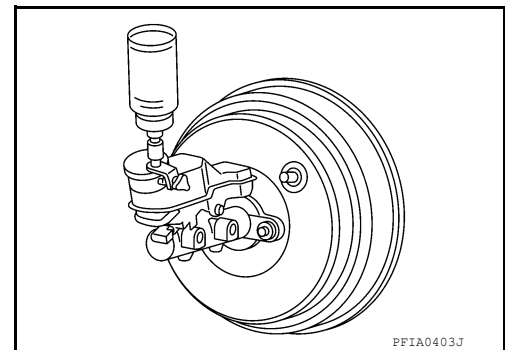

### Bleeding Brake System

INFOID:000000007356617

#### CAUTION:

- Refill with new brake fluid. Refer to [MA-18, "FOR USA AND CANADA : Fluids and Lubricants"](#) (United States and Canada), [MA-20, "FOR MEXICO : Fluids and Lubricants"](#) (Mexico).

# BRAKE FLUID

## < PERIODIC MAINTENANCE >

---

- Do not reuse drained brake fluid.
  - Do not let brake fluid splash on the painted surfaces of the body. This might damage the paint, so when splashing it, immediately wipe off the area and wash away with water.
  - Before servicing, disconnect ABS actuator and electric unit (control unit) connector or battery negative terminal.
  - While bleeding, monitor the master cylinder brake fluid level.
1. Turn ignition switch OFF and disconnect ABS actuator and electric unit (control unit) connector or battery negative terminal.
  2. Connect a vinyl tube to the rear right bleed valve.
  3. Fully depress brake pedal 4 to 5 times.
  4. With brake pedal depressed, loosen bleed valve to let the air out, and then tighten it immediately.
  5. Repeat steps 3 and 4 until no more air comes out.
  6. Tighten bleed valve to the specified torque. Refer to [BR-42. "Exploded View of Brake Caliper"](#) (front disc brake), [BR-47. "Exploded View of Brake Caliper"](#) (rear disc brake).
  7. Perform steps 2 to 6 at each wheel, with master cylinder reservoir tank filled at least half way, bleed air from the front left, rear left, and front right bleed valve, in that order.

A  
B  
C  
D  
E  
G  
H  
I  
J  
K  
L  
M  
N  
O  
P

BR

# BRAKE PEDAL

< REMOVAL AND INSTALLATION >

## REMOVAL AND INSTALLATION

### BRAKE PEDAL

Exploded View

INFOID:000000007356618

Adjustable Brake Pedal

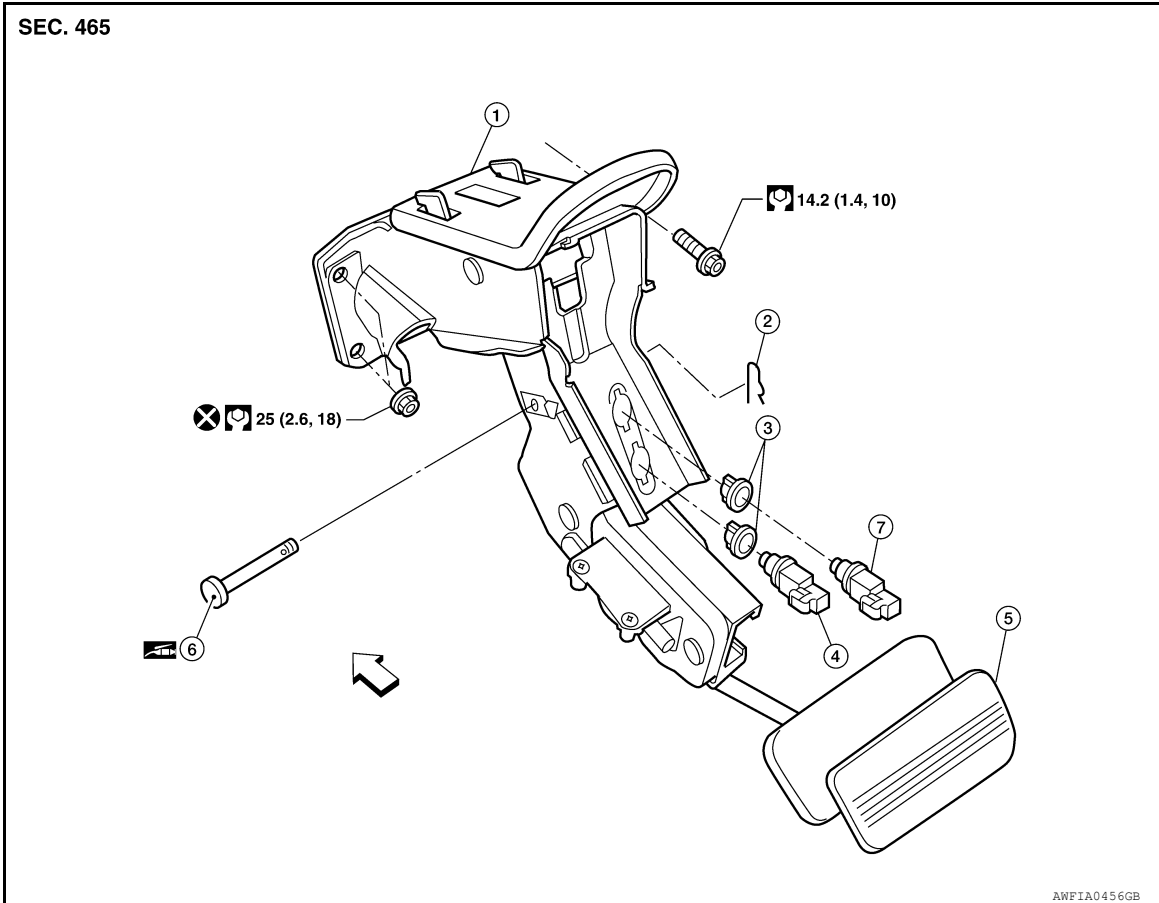

- |                         |              |               |
|-------------------------|--------------|---------------|
| 1. Brake pedal assembly | 2. Snap pin  | 3. Clip       |
| 4. Stop lamp switch     | 5. Pedal pad | 6. Clevis pin |
| 7. ASCD cancel switch   | ← Front      |               |

**NOTE:**

The clevis pin may be installed from either direction.

# BRAKE PEDAL

< REMOVAL AND INSTALLATION >

## Standard Brake Pedal

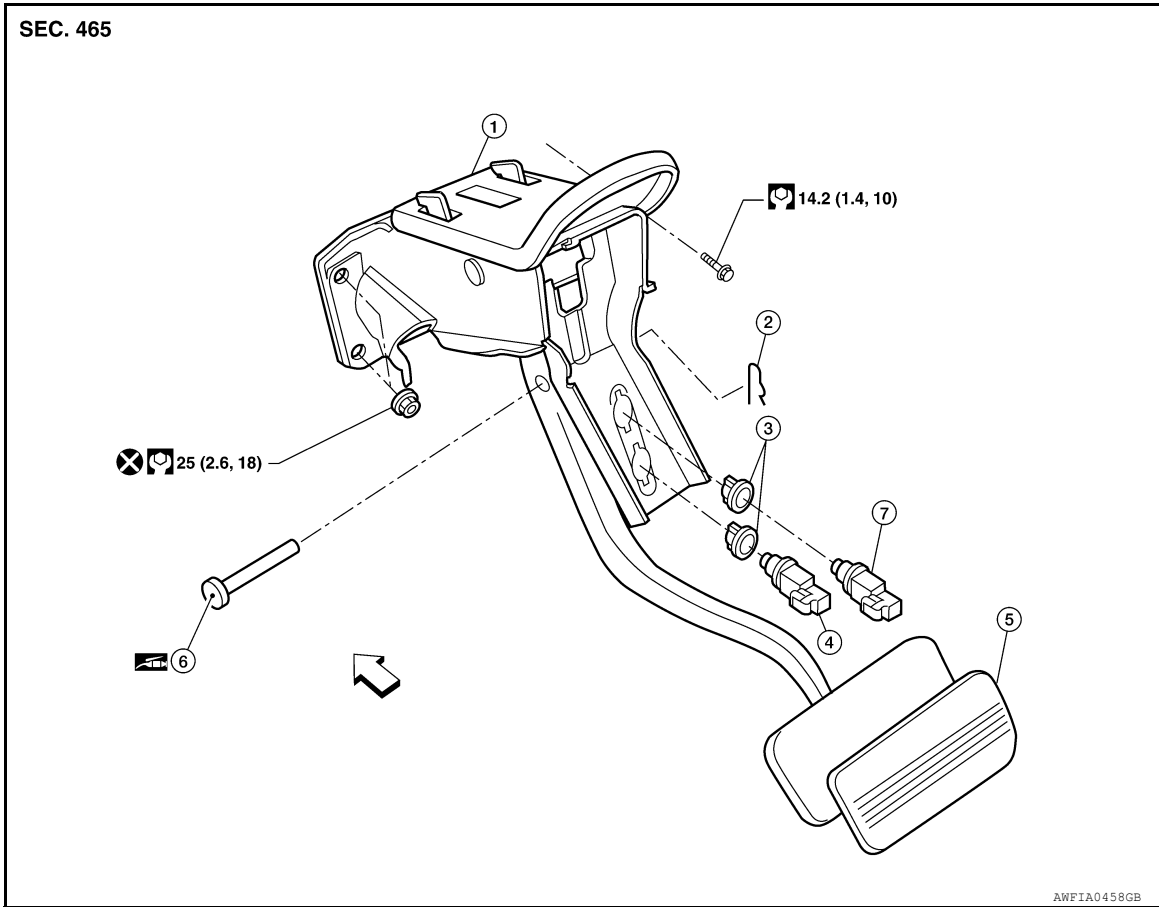

- |                         |              |               |
|-------------------------|--------------|---------------|
| 1. Brake pedal assembly | 2. Snap pin  | 3. Clip       |
| 4. Stop lamp switch     | 5. Pedal pad | 6. Clevis pin |
| 7. ASCD cancel switch   | ← Front      |               |

### NOTE:

The clevis pin may be installed from either direction.

## Removal and Installation

INFOID:000000007356619

### ADJUSTABLE BRAKE PEDAL

#### WARNING:

Do not deform the brake piping.

#### CAUTION:

- Before removal and installation the accelerator and brake pedals must be in the forward most position (closest to the floor). This is to align the base position of the accelerator and brake pedals.
- Do not disassemble the brake pedal adjusting mechanism.
- Avoid damage from dropping the brake pedal assembly during handling.
- Keep the brake pedal assembly away from water.

### Removal

1. Remove the instrument lower panel LH. Refer to [IP-15, "Removal and Installation"](#).
2. Remove the stop lamp switch and ASCD cancel switch from the brake pedal assembly.

# BRAKE PEDAL

## < REMOVAL AND INSTALLATION >

3. Disconnect the adjustable brake pedal cable from the adjustable pedal.
  - Release the two lock tabs, then pull the adjustable brake pedal cable to disconnect it from the adjustable brake pedal.

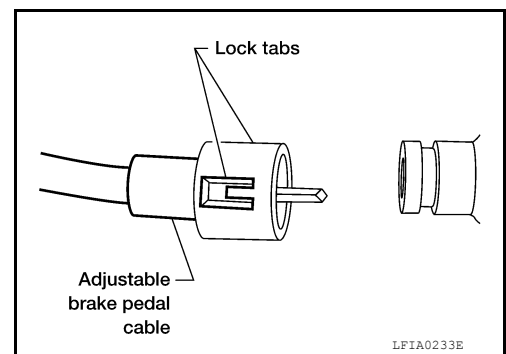

4. Remove snap pin and clevis pin from the clevis of the brake booster.
5. Remove the brake pedal assembly bolt.
6. Remove the brake pedal assembly nuts, then remove the pedal assembly.
  - Temporarily install the nuts by hand to support the booster.

### **CAUTION:**

**Do not reuse the nuts for installation.**

### Inspection After Removal

Check brake pedal for following items:

- Cracking or deformation of the clevis pin stopper (A)
- Clevis pin deformation
- Crack of any welded portion
- Brake pedal bent or deformed

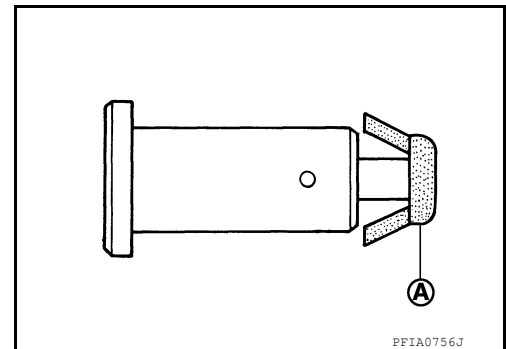

### Installation

Installation is in the reverse order of removal.

### **CAUTION:**

**Do not reuse the nuts for installation, discard and install with new lock nuts.**

- Check the brake pedal for smooth operation. There should be no binding or sticking when applying or releasing the brake pedal.
- Check the adjustable feature for smooth operation. There should be no binding or sticking when adjusting the brake pedal forward and backward.
- After installing the brake pedal assembly, adjust it as necessary. Refer to [BR-18, "Inspection and Adjustment - Adjustable Pedal"](#).

## STANDARD BRAKE PEDAL

### **WARNING:**

**Do not deform the brake piping.**

### **CAUTION:**

- **Do not disassemble the brake pedal assembly.**
- **Avoid damage from dropping the brake pedal assembly during handling.**
- **Keep the brake pedal assembly away from water.**

### Removal

1. Remove the instrument lower panel LH. Refer to [IP-15, "Removal and Installation"](#).
2. Remove the stop lamp switch and ASCD cancel switch from the pedal assembly.
3. Remove snap pin and clevis pin from the clevis of the brake booster.
4. Remove the brake pedal assembly bolt.
5. Remove the brake pedal assembly nuts, then remove the pedal assembly.
  - Temporarily install the nuts by hand to support the booster.

### **CAUTION:**



## BRAKE PEDAL

### < REMOVAL AND INSTALLATION >

**Do not reuse the nuts for installation.**

#### Inspection After Removal

Check brake pedal for following items:

- Cracking or deformation of clevis pin stopper (A)
- Clevis pin deformation
- Crack of any welded portion
- Brake pedal bent or deformed

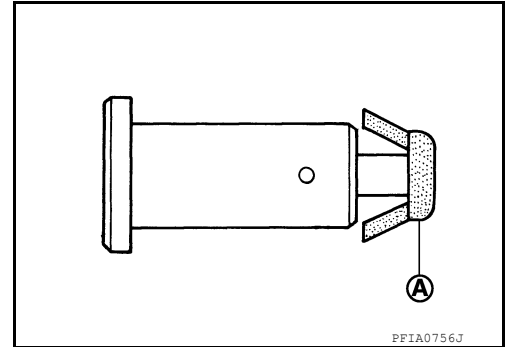

#### Installation

Installation is in the reverse order of removal.

#### **CAUTION:**

**Do not reuse the nuts for installation, discard and install with new lock nuts.**

- Check the brake pedal for smooth operation. There should be no binding or sticking when applying or releasing the brake pedal.
- After installing the brake pedal assembly, adjust it as necessary. Refer to [BR-17. "Inspection and Adjustment - Standard Pedal"](#).

# BRAKE TUBE AND HOSE

< REMOVAL AND INSTALLATION >

## BRAKE TUBE AND HOSE

### Hydraulic Circuit

INFOID:000000007356620

#### Brake Tube and Hose Connections

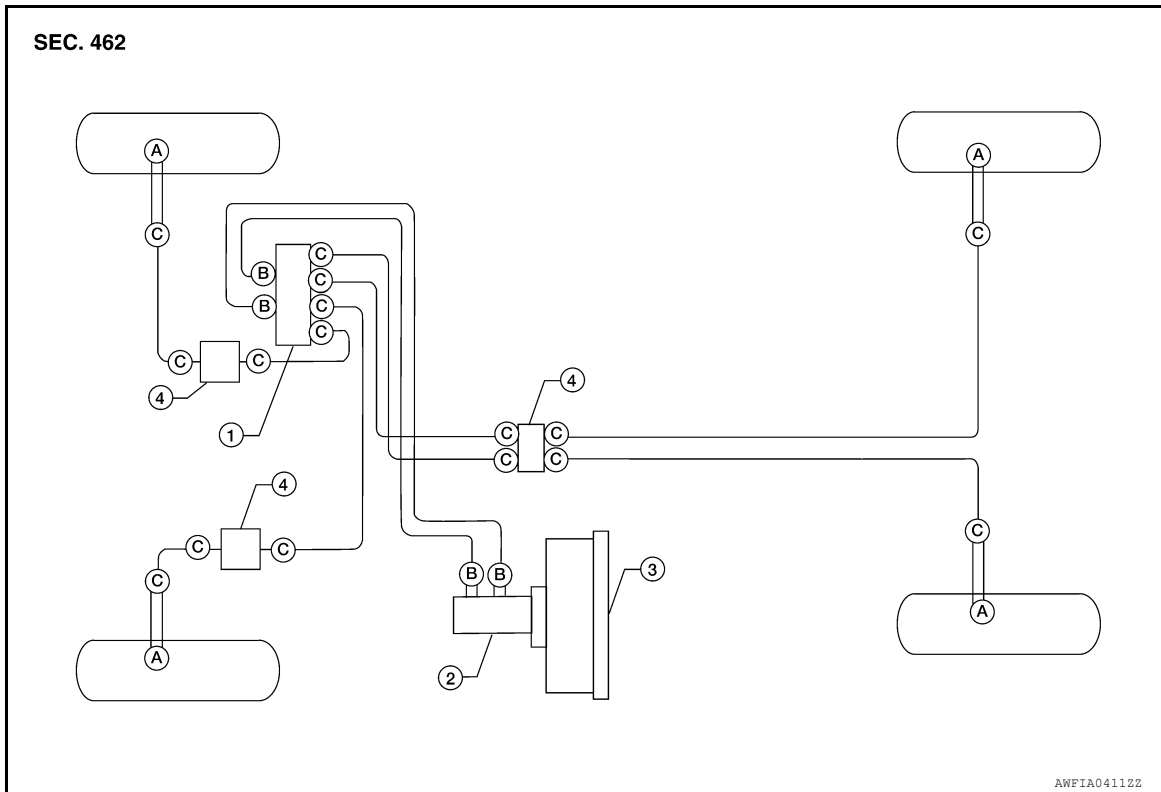

- |   |  |   |
|---|--|---|
| 1. Actuator                                       | 2. Master cylinder                             | 3. Brake booster                                  |
| 4. Connector                                      | A. Union bolt<br>18.2 N·m (1.9 kg-m, 13 ft-lb) | B. Flare nut M12<br>18.2 N·m (1.9 kg-m, 13 ft-lb) |
| C. Flare nut M10<br>13.0 N·m (1.3 kg-m, 10 ft-lb) |  |   |

# BRAKE TUBE AND HOSE

< REMOVAL AND INSTALLATION >

## ABS Actuator and Electric Unit Brake Pipe Connections for VQ40DE

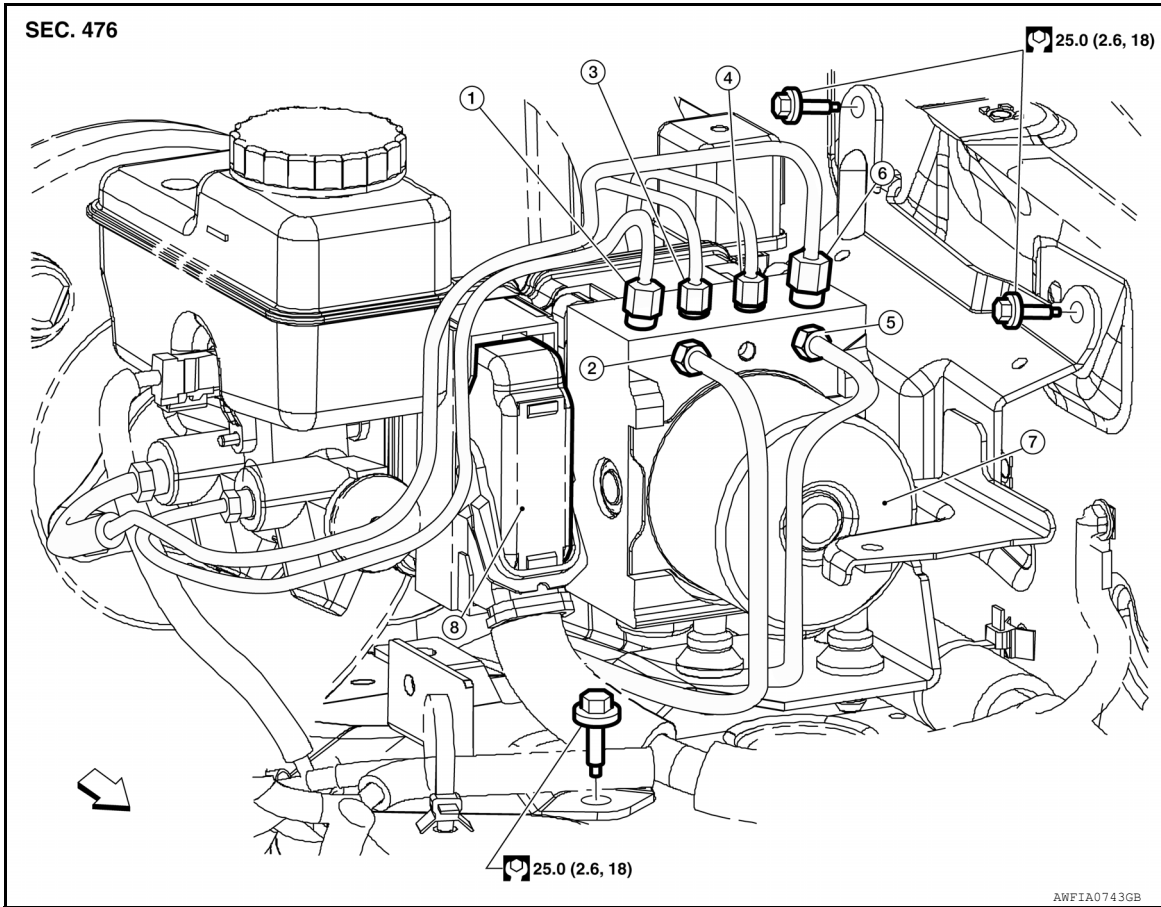

- |   |  |   |
|---|--|---|
| 1. From master cylinder secondary side<br>18.2 N·m (1.9 kg-m, 13 ft-lb) | 2. To rear right disc brake<br>13.0 N·m (1.3 kg-m, 10 ft-lb) | 3. To rear left disc brake<br>13.0 N·m (1.3 kg-m, 10 ft-lb)           |
| 4. To front right disc brake<br>13.0 N·m (1.3 kg-m, 10 ft-lb)           | 5. To front left disc brake<br>13.0 N·m (1.3 kg-m, 10 ft-lb) | 6. From master cylinder primary side<br>18.2 N·m (1.9 kg-m, 13 ft-lb) |
| 7. ABS actuator and electric unit (control unit)                        | 8. Harness connector   | ⇐ Front   |

A  
B  
C  
D  
E  
BR  
G  
H  
I  
J  
K  
L  
M  
N  
O  
P

# BRAKE TUBE AND HOSE

< REMOVAL AND INSTALLATION >

## ABS Actuator and Electric Unit Brake Pipe Connections for VK56DE

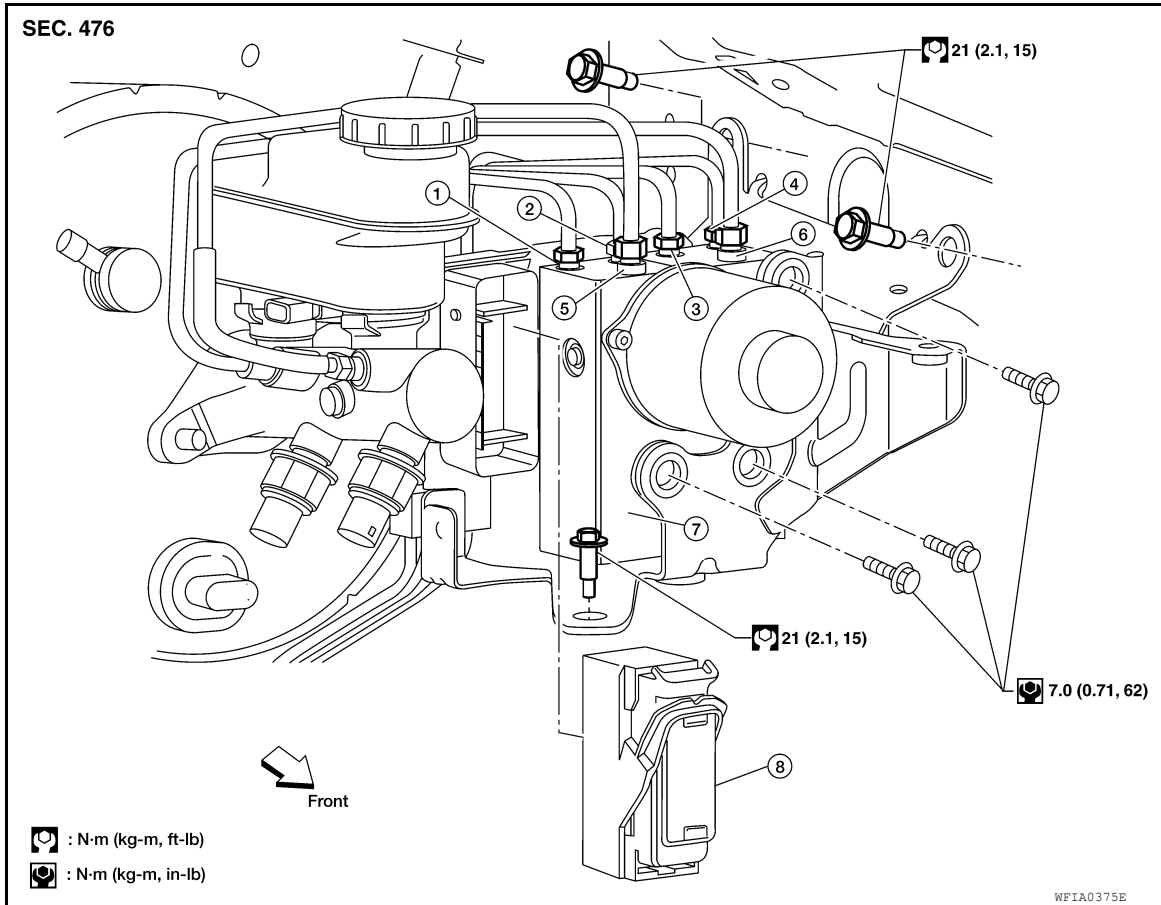

- |   |   |   |
|---|---|---|
| 1. To rear left disc brake<br>13.0 N·m (1.3 kg-m, 10 ft-lb)   | 2. To rear right disc brake<br>13.0 N·m (1.3 kg-m, 10 ft-lb)                | 3. To front left disc brake<br>13.0 N·m (1.3 kg-m, 10 ft-lb)              |
| 4. To front right disc brake<br>13.0 N·m (1.3 kg-m, 10 ft-lb) | 5. From the master cylinder secondary side<br>18.2 N·m (1.9 kg-m, 13 ft-lb) | 6. From the master cylinder primary side<br>18.2 N·m (1.9 kg-m, 13 ft-lb) |
| 7. ABS actuator and electric unit<br>(control unit)           | 8. Harness connector  |   |

### CAUTION:

- All hoses and piping (tubes) must be free from excessive bending, twisting and pulling.
- Make sure there is no interference with other parts when turning the steering wheel both clockwise and counterclockwise.
- The brake piping is an important safety part. If a brake fluid leak is detected, always disassemble the parts. Replace applicable part with a new one, if necessary.
- Be careful not to splash brake fluid on painted areas; it may cause paint damage. If brake fluid is splashed on painted areas, wash it away with water immediately.
- Do not bend or twist brake hose sharply, or strongly pull it.
- When removing components, cover connections so that no dirt, dust, or other foreign matter gets in.
- Refill with new specified brake fluid. Refer to [MA-18, "FOR USA AND CANADA : Fluids and Lubricants"](#) (United States and Canada), [MA-20, "FOR MEXICO : Fluids and Lubricants"](#) (Mexico).
- Do not reuse drained brake fluid.

### Removal and Installation of Front Brake Piping and Brake Hose

INFOID:000000007356621

#### NOTE:

When removing components such as hoses, tubes/lines, etc., cap or plug openings to prevent fluid from spilling.

#### REMOVAL

1. Remove wheel and tire assembly.
2. Remove master cylinder reservoir cap.

# BRAKE TUBE AND HOSE

## < REMOVAL AND INSTALLATION >

3. Remove brake tube from brake hose, using a suitable tool.
4. Remove lock plate and brake hose from bracket.

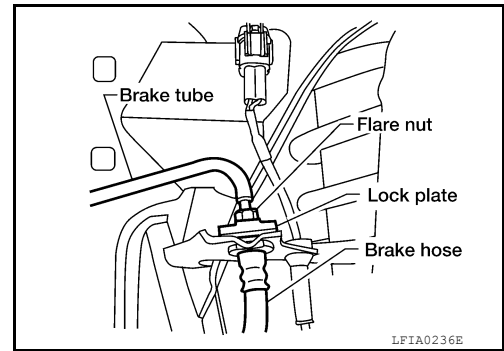

5. Remove union bolt and copper sealing washers, then remove brake hose from caliper assembly.

**CAUTION:**

**Do not reuse copper sealing washers.**

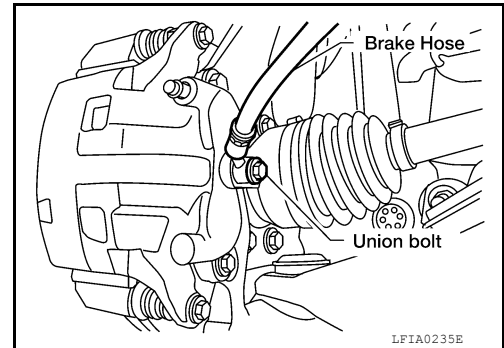

## INSTALLATION

1. Install brake hose by aligning with the protrusion on caliper assembly, then install new copper sealing washers (1) and union bolt (A). Tighten union bolt (A) to specified torque. Refer to [BR-26. "Hydraulic Circuit"](#).

**CAUTION:**

**Do not reuse copper sealing washers.**

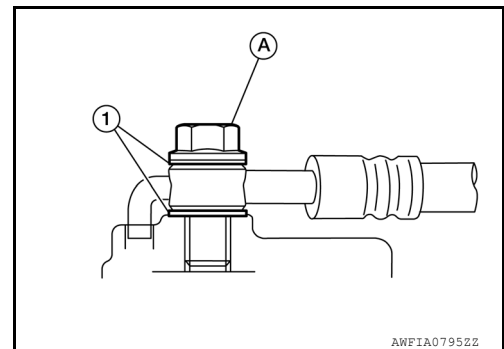

2. Insert brake hose end through bracket, then secure it to bracket with lock plate.
3. Install brake tube to brake hose, then tighten flare nut to the specified torque using a suitable tool. Refer to [BR-26. "Hydraulic Circuit"](#).

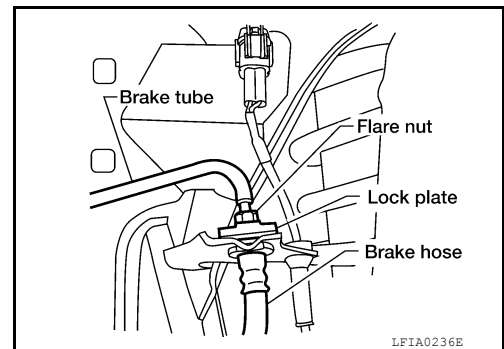

4. Refill brake fluid and bleed brake system. Refer to [BR-20. "Bleeding Brake System"](#).
5. Install the wheel and tire assembly. Refer to [WT-50. "Adjustment"](#).

## Removal and Installation of Rear Brake Piping and Brake Hose

INFOID:000000007356622

**NOTE:**

When removing components such as hoses, tubes/lines, etc., cap or plug openings to prevent fluid from spilling.

## REMOVAL

1. Remove wheel and tire assembly.

# BRAKE TUBE AND HOSE

## < REMOVAL AND INSTALLATION >

2. Remove master cylinder reservoir cap.
3. Remove brake tube from brake hose, using a suitable tool.
4. Remove lock plate and brake hose from bracket.

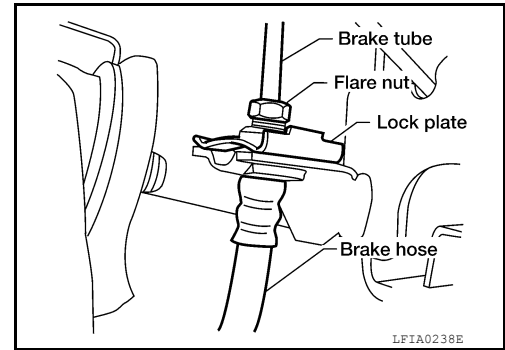

5. Remove union bolt and copper sealing washers, then remove brake hose from caliper assembly.

### **CAUTION:**

**Do not reuse copper sealing washers.**

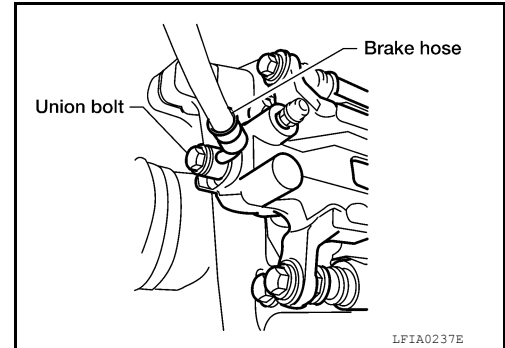

## INSTALLATION

1. Install brake hose by aligning with the protrusion on caliper assembly, then install new copper sealing washers (1) and union bolt (A). Tighten union bolt (A) to specified torque. Refer to [BR-26, "Hydraulic Circuit"](#).

### **CAUTION:**

**Do not reuse copper sealing washers.**

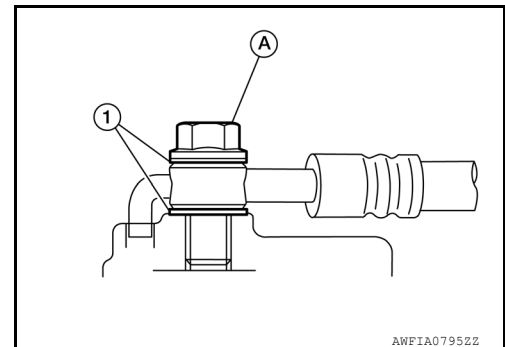

2. Insert brake hose end through bracket, then secure it to bracket with lock plate.
3. Install brake tube to brake hose, then tighten flare nut to the specified torque using a suitable tool.

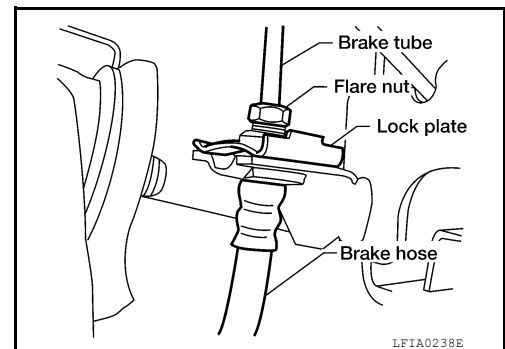

4. Refill brake fluid and bleed brake system. Refer to [BR-20, "Bleeding Brake System"](#).
5. Install the wheel and tire assembly. Refer to [WT-50, "Adjustment"](#).

## Inspection After Installation

INFOID:000000007356623

### **CAUTION:**

**Brake tubes and hoses are important safety parts. Always disassemble the parts and retighten their fittings if a brake fluid leak is detected. Replace applicable part with a new one, if a damaged part is detected.**

# BRAKE TUBE AND HOSE

## < REMOVAL AND INSTALLATION >

1. Check brake pipes and hoses, and connections for fluid leaks, damage, twist, deformation, contact with other parts, and loose connections. Replace any parts as necessary. Refer to [BR-26, "Hydraulic Circuit"](#).
2. While depressing brake pedal under a force of 785 N (80 kg-f, 177 lb-f) with engine running for approximately 5 seconds, check each part for fluid leaks.

A  
B  
C  
D  
E  
G  
H  
I  
J  
K  
L  
M  
N  
O  
P

**BR**

# BRAKE MASTER CYLINDER

< REMOVAL AND INSTALLATION >

## BRAKE MASTER CYLINDER

### Removal and Installation

INFOID:000000007356624

VQ40DE

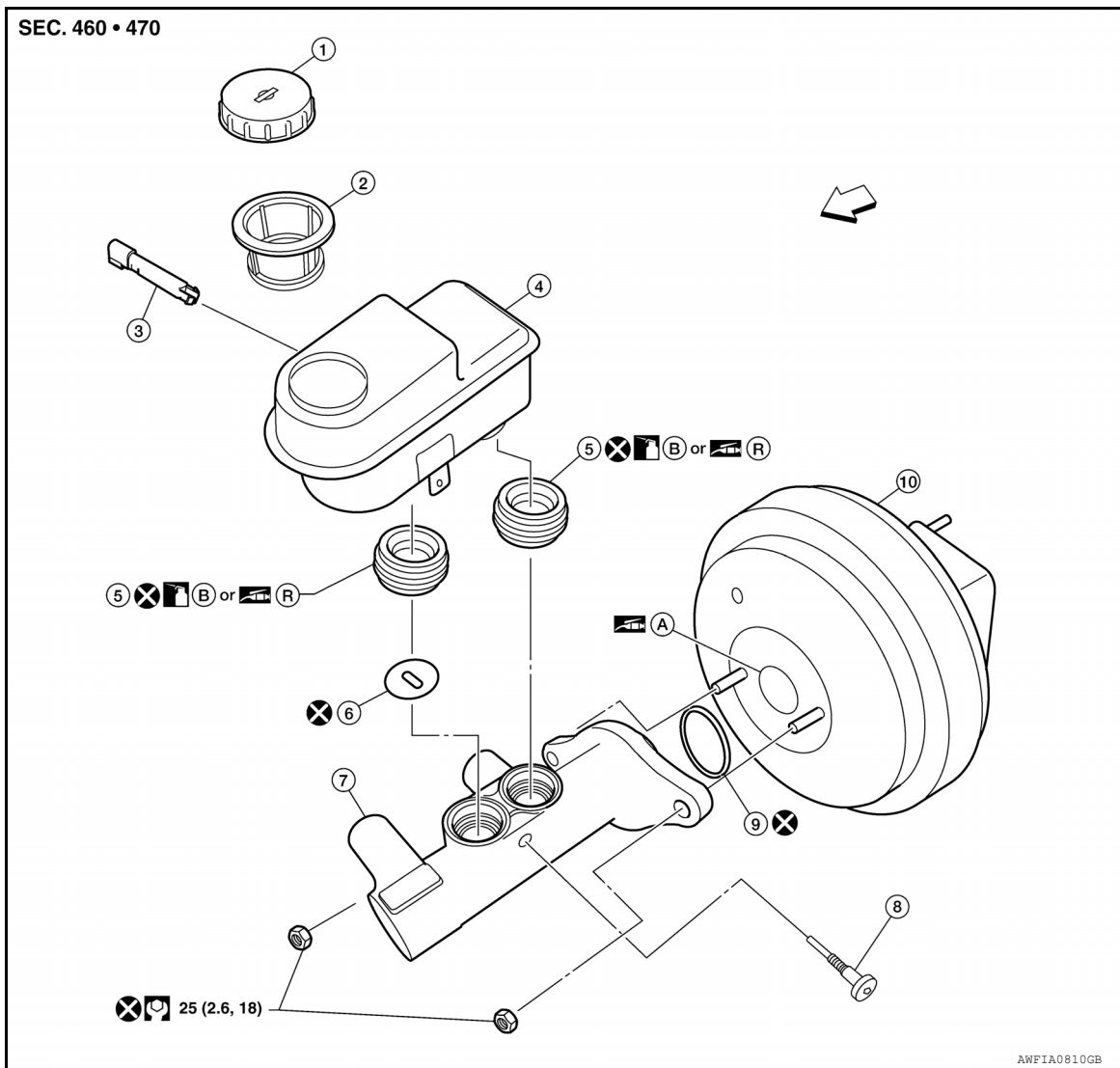

- |                                 |  |                       |
|---------------------------------|--|-----------------------|
| 1. Reservoir cap                | 2. strainer  | 3. Fluid level sensor |
| 4. Reservoir tank               | 5. Grommet   | 6. Restriction washer |
| 7. Master cylinder sub-assembly | 8. Pin   | 9. O-ring             |
| 10. Brake booster               | A. PBC (Poly Butyl Cuprysil) grease or silicone based grease | B. Brake fluid        |
| R. Rubber grease                | ↩ Front  |                       |

### REMOVAL

#### CAUTION:

Be careful not to splash brake fluid on painted areas; it may cause paint damage. If brake fluid is splashed on painted areas, wash it away with water immediately.

#### NOTE:

When removing components such as hoses, tubes/lines, etc., cap or plug openings to prevent fluid from spilling.

1. Remove master cylinder reservoir cap.
2. Disconnect the harness connector for the fluid level sensor.
3. Disconnect the brake pipes from the master cylinder assembly, using suitable tool.



# BRAKE MASTER CYLINDER

## < REMOVAL AND INSTALLATION >

- Remove the master cylinder assembly nuts and discard.

**CAUTION:**

**Discard the nuts, do not reuse.**

- Remove the master cylinder assembly and O-ring.

**CAUTION:**

**Do not reuse O-ring.**

## INSTALLATION

Installation is in the reverse order of removal.

- Apply silicone grease to the brake booster at position (A) as shown when installing the master cylinder assembly to the brake booster.
- Use new master cylinder assembly nuts and O-ring for installation.

**CAUTION:**

**Do not reuse the master cylinder assembly nuts or O-ring.**

- Refill the brake fluid and bleed the brake system. Refer to [BR-20, "Bleeding Brake System"](#).

**CAUTION:**

- Refill using recommended brake fluid. Refer to [BR-20, "Drain and Refill"](#).
- Do not reuse drained brake fluid.

- Adjust the brake pedal. Refer to [BR-17, "Inspection and Adjustment - Standard Pedal"](#), [BR-18, "Inspection and Adjustment - Adjustable Pedal"](#).

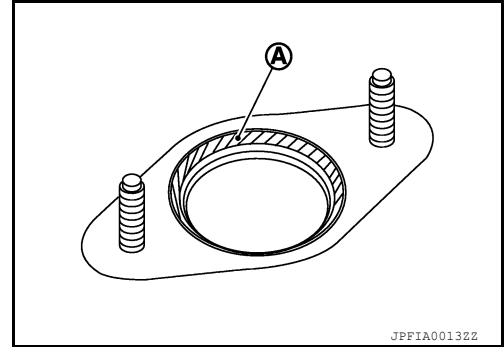

VK56DE

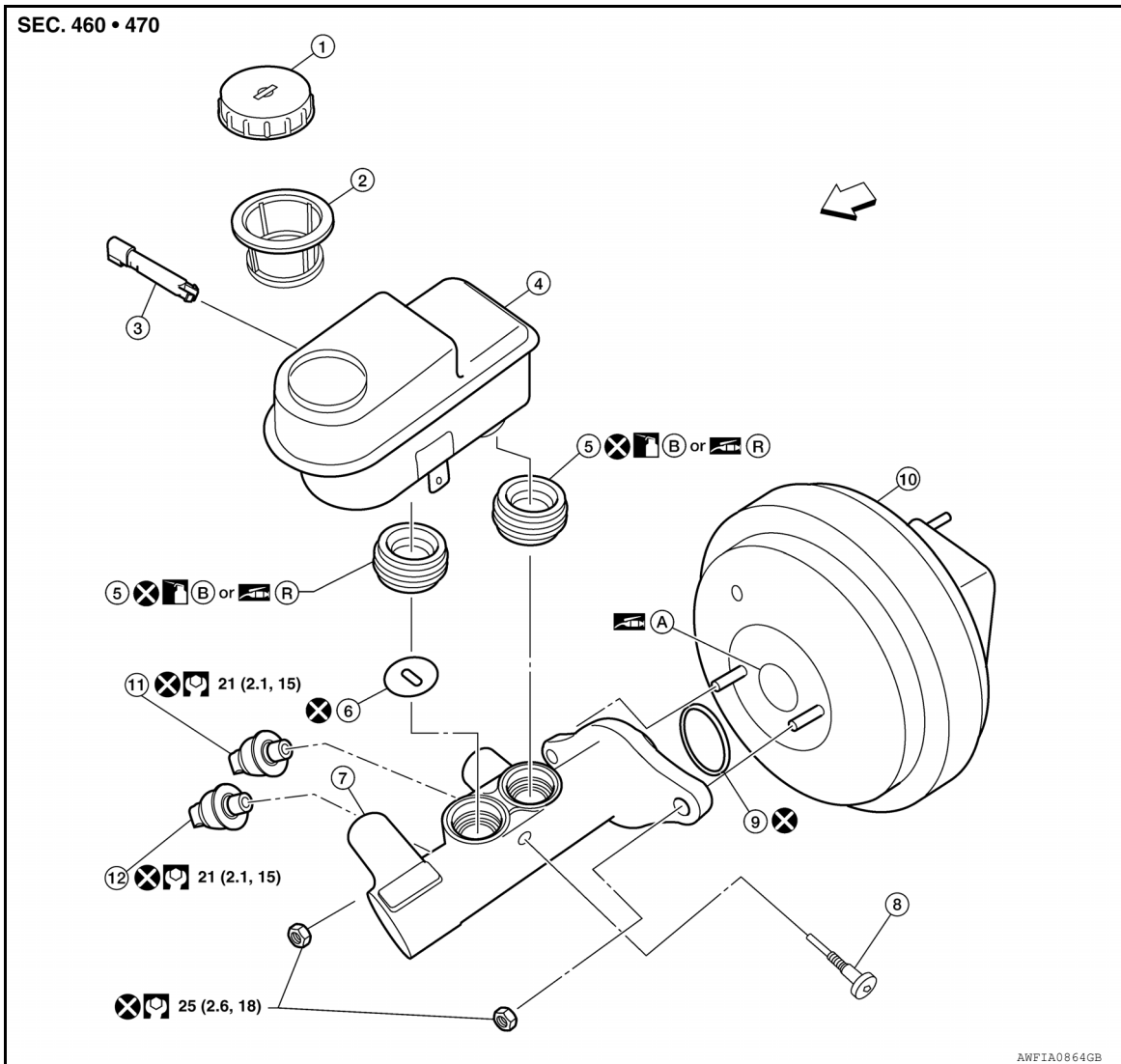

# BRAKE MASTER CYLINDER

## < REMOVAL AND INSTALLATION >

- |  |                           |                          |
|--|---------------------------|--------------------------|
| 1. Reservoir cap   | 2. Strainer               | 3. Fluid level sensor    |
| 4. Reservoir tank  | 5. Grommet                | 6. Restriction washer    |
| 7. Master cylinder sub-assembly                              | 8. Pin                    | 9. O-ring                |
| 10. Brake booster  | 11. Front pressure sensor | 12. Rear pressure sensor |
| A. PBC (Ploy Butyl Cuprisil) grease or silicone based grease | B. Brake fluid            | R. Rubber grease         |

⇐ Front

### REMOVAL

#### CAUTION:

- **Be careful not to splash brake fluid on painted areas; it may cause paint damage. If brake fluid is splashed on painted areas, wash it away with water immediately.**
- **Before removing brake master cylinder, depress the brake pedal 5-6 times with the key OFF to deplete vacuum in the booster.**

#### NOTE:

When removing components such as hoses, tubes/lines, etc., cap or plug openings to prevent fluid from spilling.

1. Remove master cylinder reservoir cap.
2. Disconnect harness connectors for fluid level sensor, rear pressure sensor and front pressure sensor.
3. Disconnect brake pipes from the master cylinder assembly, using suitable tool.
4. Remove the master cylinder assembly nuts and discard.

#### CAUTION:

**Discard the nuts, do not reuse.**

5. Remove the master cylinder assembly and O-ring.

#### CAUTION:

**Do not reuse O-ring.**

### INSTALLATION

Installation is in the reverse order of removal.

- Apply silicone grease to the brake booster at position (A) as shown, be sure O-ring is in the proper position when installing the master cylinder assembly to the brake booster.
- Use new master cylinder assembly nuts and O-ring for installation.

#### CAUTION:

**Do not reuse the master cylinder assembly nuts or O-ring.**

- Refill the brake fluid and bleed the brake system. Refer to [BR-20, "Bleeding Brake System"](#).

#### CAUTION:

- **Refill using recommended brake fluid. Refer to [BR-20, "Drain and Refill"](#).**
- **Do not reuse drained brake fluid.**
- Adjust the brake pedal. Refer to [BR-17, "Inspection and Adjustment - Standard Pedal"](#), [BR-18, "Inspection and Adjustment - Adjustable Pedal"](#).

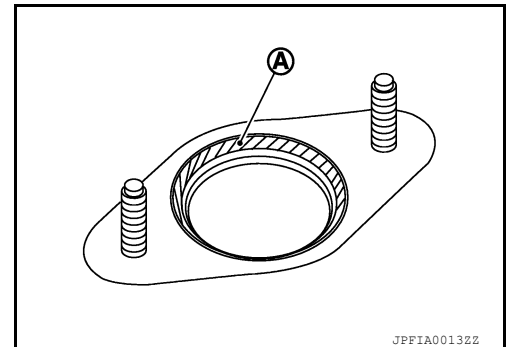

# BRAKE BOOSTER

< REMOVAL AND INSTALLATION >

## BRAKE BOOSTER

### Removal and Installation

INFOID:000000007356625

VQ40DE

SEC. 470

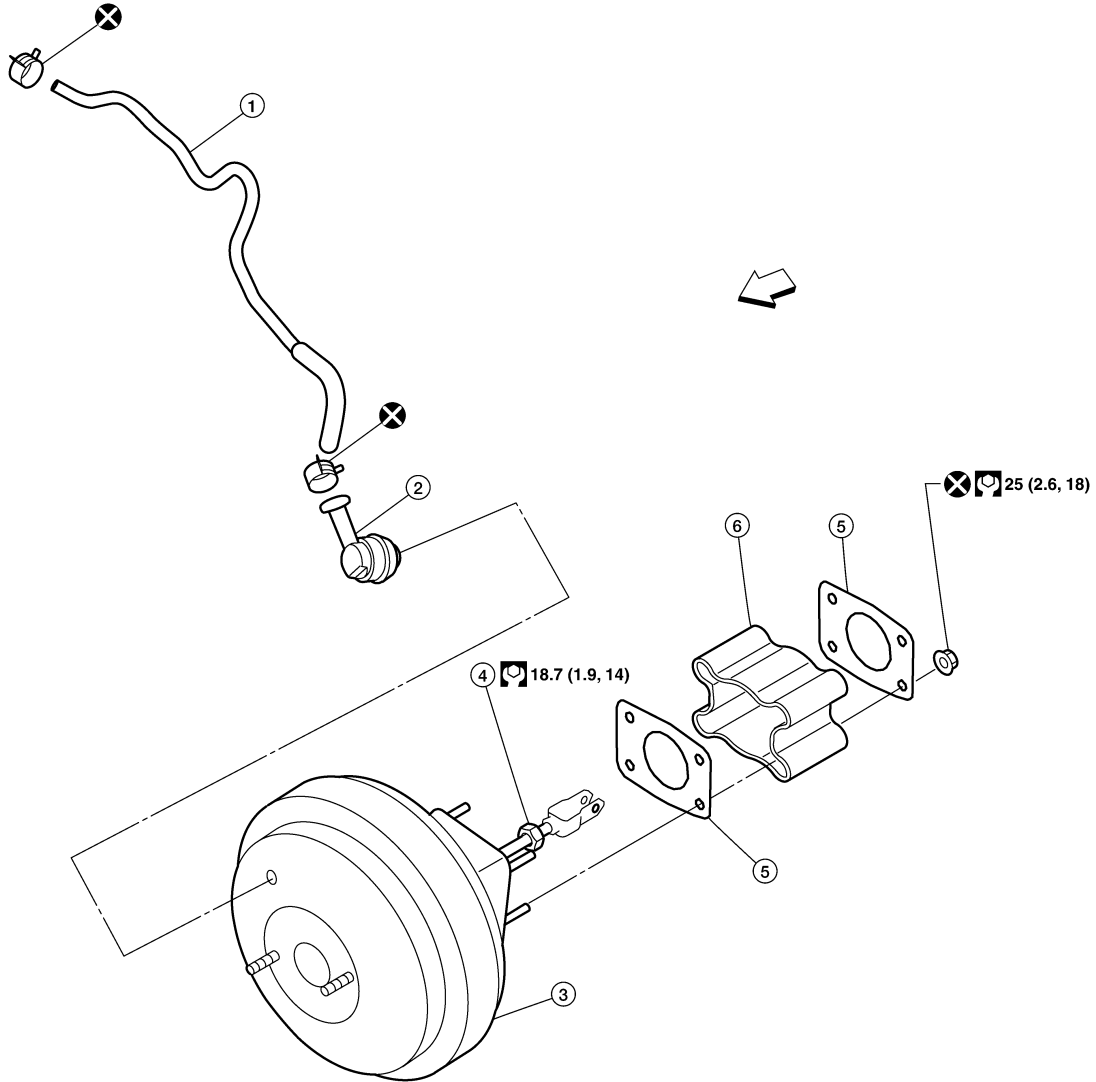

- |                              |                                     |                  |
|------------------------------|-------------------------------------|------------------|
| 1. Brake booster vacuum hose | 2. Brake booster vacuum check valve | 3. Brake booster |
| 4. Lock nut                  | 5. Gasket                           | 6. Spacer block  |

⇐ Front

AWFIA0463GB

# BRAKE BOOSTER

< REMOVAL AND INSTALLATION >

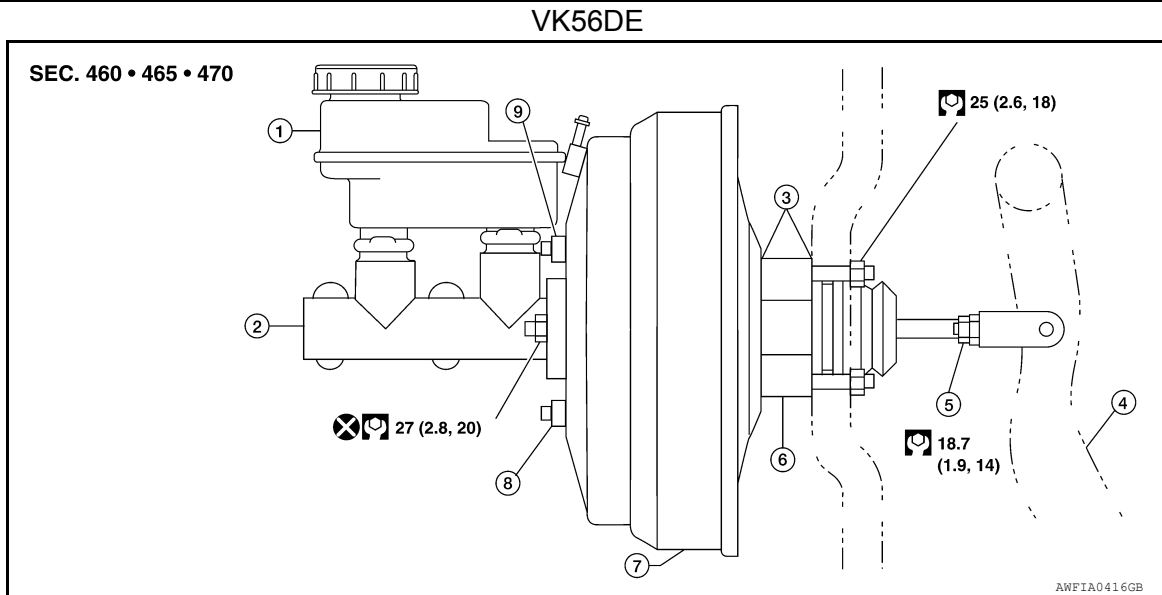

- |                   |                             |                        |
|-------------------|-----------------------------|------------------------|
| 1. Reservoir tank | 2. Master cylinder assembly | 3. Gasket              |
| 4. Brake pedal    | 5. Lock nut                 | 6. Spacer block        |
| 7. Brake booster  | 8. Active booster           | 9. Delta stroke sensor |

## REMOVAL

### CAUTION:

- Be careful not to deform or bend brake piping while removing and installing brake booster.
- Replace clevis pin if it is damaged.
- Be careful not to damage brake booster stud bolt threads. If brake booster is tilted or inclined during installation, dash panel may damage the threads.
- Attach the check valve in the correct direction.

### NOTE:

When removing components such as hoses, tubes/lines, etc., cap or plug openings to prevent fluid from spilling.

1. Remove the ABS actuator and electric unit (control unit). Refer to [BRC-231, "Removal and Installation"](#).
2. Remove the master cylinder assembly. Refer to [BR-32, "Removal and Installation"](#).
3. Disconnect brake booster vacuum hose from the brake booster. Refer to [BR-38, "Removal and Installation"](#).
4. Disconnect the active booster and delta stroke sensor harness connector (if equipped).
5. Remove the brake pedal clevis pin (2) and snap pin (1) from inside the vehicle.

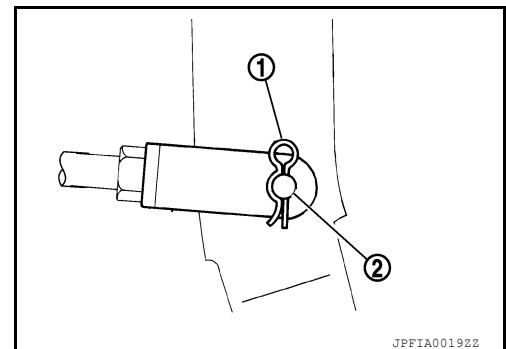

6. Remove the brake booster and brake pedal assembly nuts and discard.

### CAUTION:

**Discard the nuts, do not reuse.**

7. Remove brake booster assembly from dash panel.

## INSTALLATION

# BRAKE BOOSTER

## < REMOVAL AND INSTALLATION >

1. Loosen the lock nut to adjust the input rod so that length (B) is within the specified value.

**Input rod installation length (B) : Refer to [BR-60. "Brake Booster"](#).**

2. After adjusting input rod length (B), temporarily tighten the lock nut (1) and install the booster assembly to the dash panel.
  - Install gaskets and spacer block between the booster assembly and the dash panel.

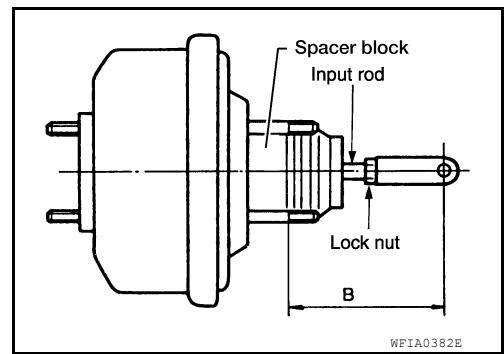

3. Connect the input rod using the brake pedal clevis pin (2) and snap pin (1) from inside the vehicle.

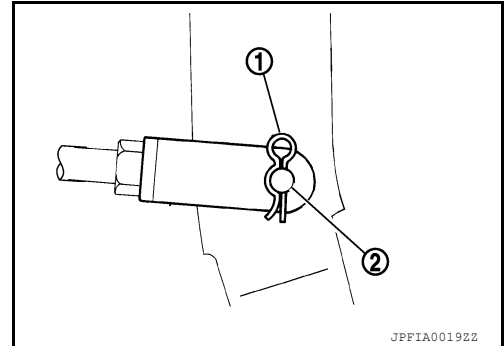

4. Install the brake booster using new nuts.

**CAUTION:**

**Do not reuse the brake booster and brake pedal assembly nuts.**

5. Install the brake piping to the brake master cylinder. Refer to [BR-26. "Hydraulic Circuit"](#).
6. Connect the active booster and delta stroke sensor harness connectors (if equipped).
7. Connect the brake booster vacuum hose and check valve to the brake booster.
8. Install the master cylinder assembly. Refer to [BR-32. "Removal and Installation"](#).
9. Adjust the brake pedal height. Refer to [BR-17. "Inspection and Adjustment - Standard Pedal"](#), [BR-18. "Inspection and Adjustment - Adjustable Pedal"](#).
10. Tighten the input rod lock nut to specification.
11. Refill with new brake fluid and bleed the brake system. Refer to [BR-20. "Drain and Refill"](#).

# VACUUM LINES

< REMOVAL AND INSTALLATION >

## VACUUM LINES

### Removal and Installation

INFOID:000000007356626

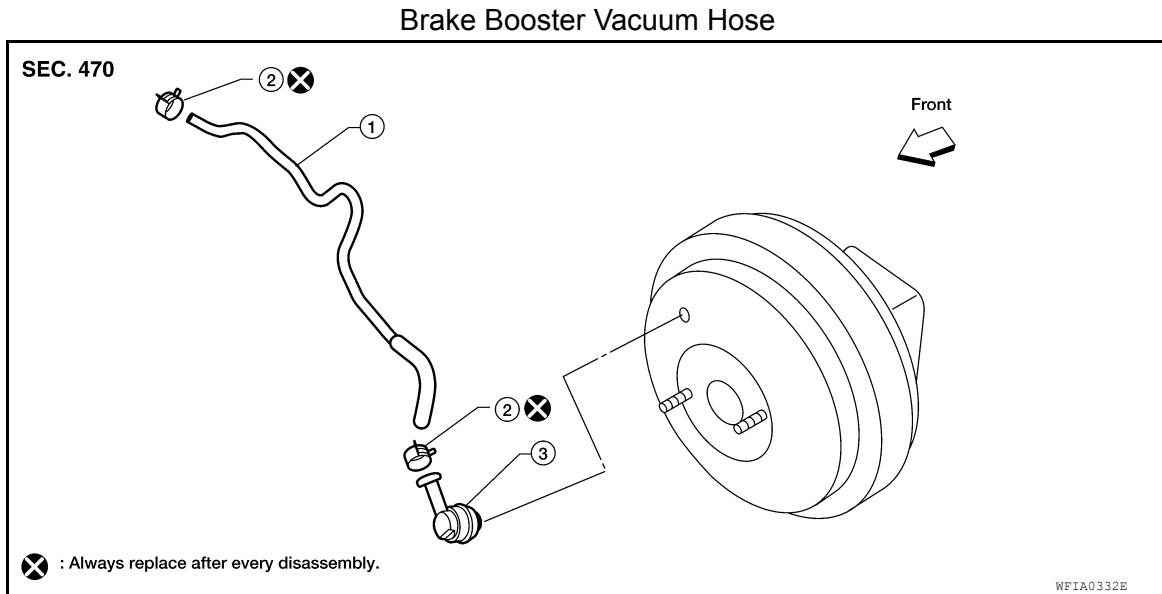

1. Brake booster hose
2. Brake booster hose clamp
3. Brake booster vacuum check valve

### REMOVAL

1. Disconnect brake booster hose from hose clip bracket.
2. Release the brake booster hose clamps and remove the brake booster hose.
3. Remove the brake booster vacuum check valve from the brake booster.

### INSTALLATION

Installation is in the reverse order of removal.

- Insert brake booster hose onto tube and brake booster vacuum check valve for a minimum length (A) before installing the brake booster hose clamps.

**Brake booster hose length (A) : 24 mm (0.94 in) or more**

### CAUTION:

**Do not use lubricating oil during installation.**

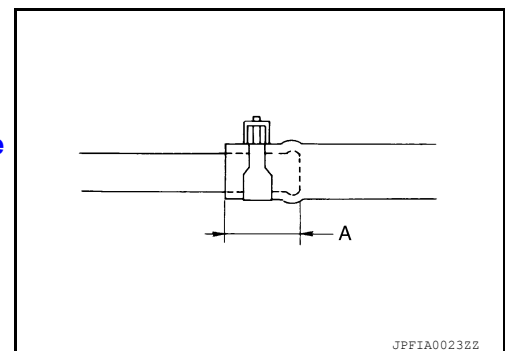

# FRONT DISC BRAKE

< REMOVAL AND INSTALLATION >

## FRONT DISC BRAKE

### Exploded View of Brake Pads

INFOID:000000007356627

Front Brake Pads, Shims and Retainers VQ40DE

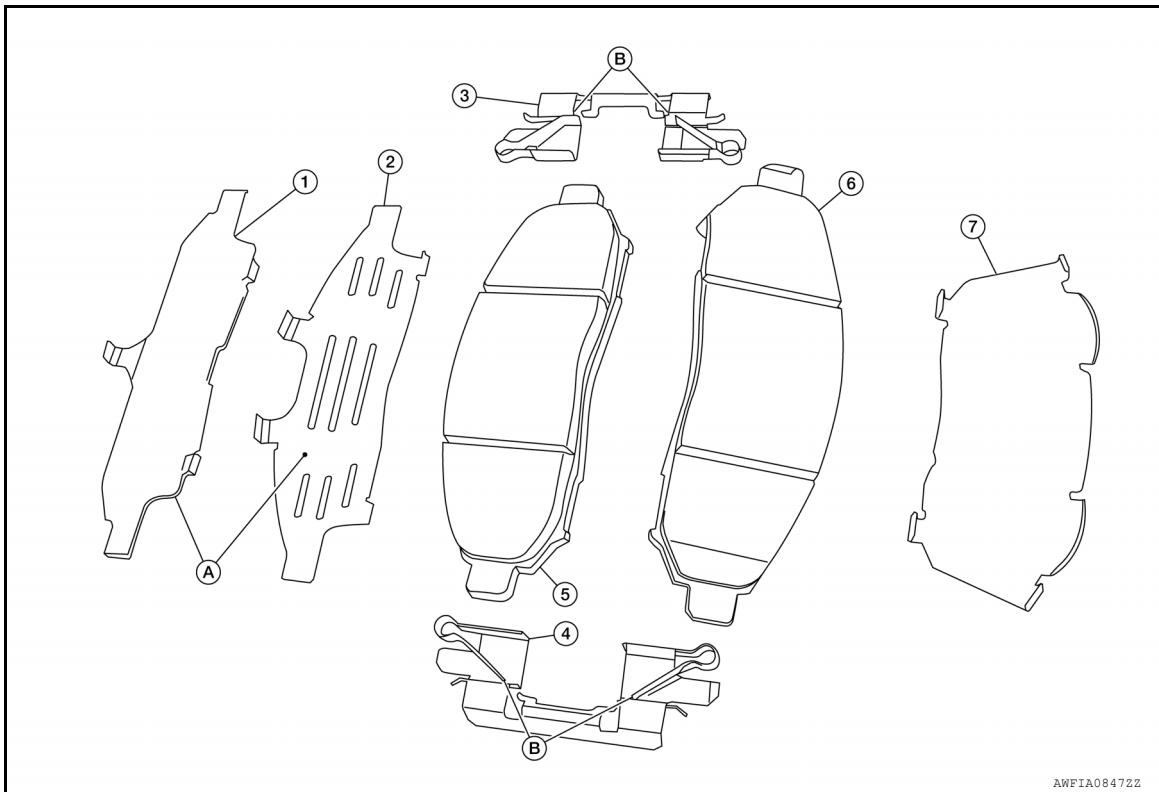

- |                       |                            |                         |
|-----------------------|----------------------------|-------------------------|
| 1. Outer shim cover   | 2. Outer shim              | 3. Upper pad retainer   |
| 4. Lower pad retainer | 5. Inner brake pad         | 6. Outer brake pad      |
| 7. Inner shim         | A. Molykote AS-880N grease | B. Molykote 7439 grease |

A  
B  
C  
D  
E  
BR  
G  
H  
I  
J  
K  
L  
M  
N  
O  
P

# FRONT DISC BRAKE

< REMOVAL AND INSTALLATION >

## Front Brake Pads, Shims and Retainers VK56DE

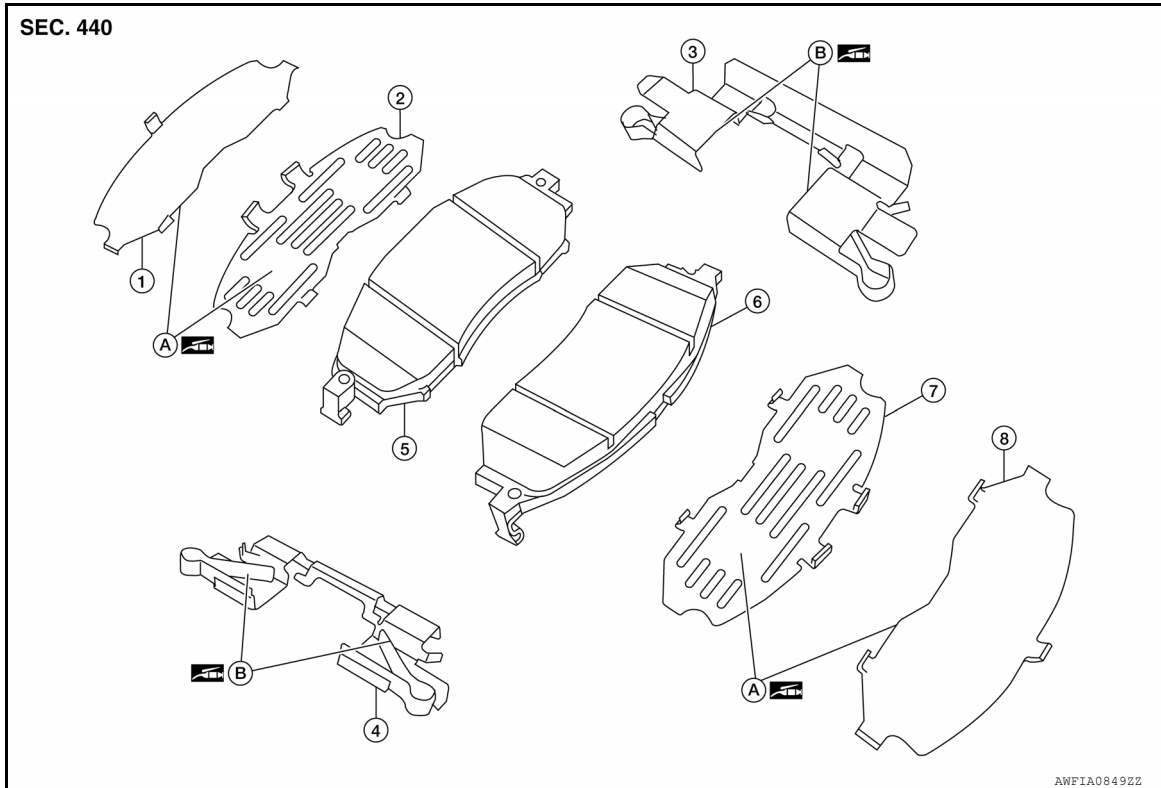

- |                         |                     |                            |
|-------------------------|---------------------|----------------------------|
| 1. Inner shim cover     | 2. Inner shim       | 3. Upper pad retainer      |
| 4. Lower pad retainer   | 5. Inner brake pad  | 6. Outer brake pad         |
| 7. Outer shim           | 8. Outer shim cover | A. Molykote AS-880N grease |
| B. Molykote 7439 grease |                     |                            |

### WARNING:

Clean dust on caliper and brake pads with a vacuum dust collector to minimize the hazard of airborne particles or other materials.

### CAUTION:

- While removing brake pads never depress brake pedal because piston will pop out.
- It is not necessary to remove bolts on torque member and brake hose except for disassembly or replacement of caliper body. In this case, hang caliper body with a wire so as not to stretch the brake hose.
- Do not damage the piston boot.
- If any shim is subject to serious corrosion, replace it with a new one.
- Always replace shim and shim cover as a set when replacing brake pads.
- Keep rotor free from grease and brake fluid.
- Burnish the brake contact surface after refinishing or replacing rotors, after replacing pads, or if a soft pedal occurs at very low mileage. Refer to [BR-41, "Brake Burnishing"](#).

## Removal and Installation of Brake Pad

INFOID:000000007356628

### REMOVAL

1. Remove the front wheel and tire. Refer to [WT-50, "Adjustment"](#).
2. Remove master cylinder reservoir cap.
3. Partially drain the brake fluid. Refer to [BR-20, "Drain and Refill"](#).
4. Remove lower sliding pin bolt using power tool and swing the caliper body up to access the brake pads.
5. Support the caliper body with a suitable wire to avoid pulling on the front brake hose.
6. Remove the front inner and outer brake pads, shims, shim covers and retainers from the torque member.

### INSTALLATION

1. Apply grease to the shims and shim covers as follows:



# FRONT DISC BRAKE

## < REMOVAL AND INSTALLATION >

- For vehicles equipped with VK56DE engine, apply Molykote AS-880N grease between the inner and outer shims and shim covers, then attach shims and shim covers to the brake pads.
  - For vehicles equipped with VQ40DE engine, apply Molykote AS-880N grease between the outer shim and shim cover, then attach the shims and outer shim cover to the brake pads.
2. Apply Molykote 7439 grease (A) to the pad retainers as shown, then install the brake pads, shims and shim covers to the torque member.

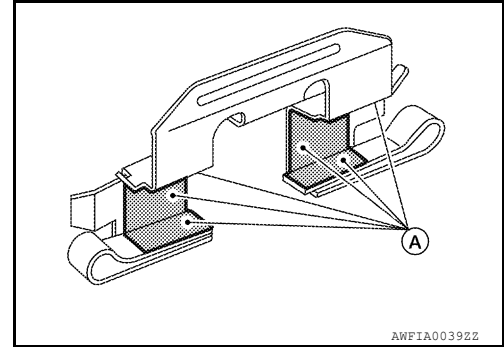

3. Attach pad retainers to torque member.

**CAUTION:**

**When attaching pad retainer, attach it firmly so that it is flush with torque member, as shown.**

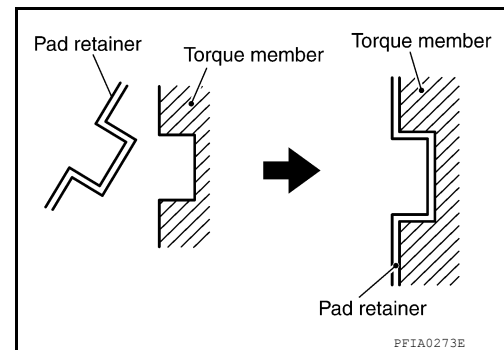

4. Using a suitable tool push pistons into caliper body.

**CAUTION:**

**When pushing in piston, brake fluid returns to master cylinder reservoir tank. Watch the level of the brake fluid in the reservoir tank.**

5. Remove the suitable wire, then swing the caliper body down over the brake pad assemblies.
6. Install the lower sliding pin bolt and tighten to specification. Refer to [BR-42, "Exploded View of Brake Caliper"](#).
7. Check the brakes for drag.
8. Inspect the brake fluid level, refill if necessary. Refer to [BR-20, "Drain and Refill"](#).
9. Install the front wheel and tire. Refer to [WT-50, "Adjustment"](#).

## Brake Burnishing

INFOID:000000007356629

Burnish brake contact surface according to the following procedure after refinishing or replacing rotors, after replacing pads, or if a soft pedal occurs at very low mileage.

**CAUTION:**

**Only perform this procedure under safe road and traffic conditions. Use extreme caution.**

1. Drive the vehicle on a straight smooth road at 50 km/h (31 MPH).
2. Use medium brake pedal/foot effort to bring the vehicle to a complete stop from 50 km/h (31 MPH). Adjust brake pedal/foot pressure such that vehicle stopping time equals 3 to 5 seconds.
3. To cool brake system, drive the vehicle at 50 km/h (31 MPH) for 1 minute without stopping.
4. Repeat steps 1 to 3, 10 times or more to complete the burnishing procedure.

# FRONT DISC BRAKE

< REMOVAL AND INSTALLATION >

## Exploded View of Brake Caliper

INFOID:000000007356630

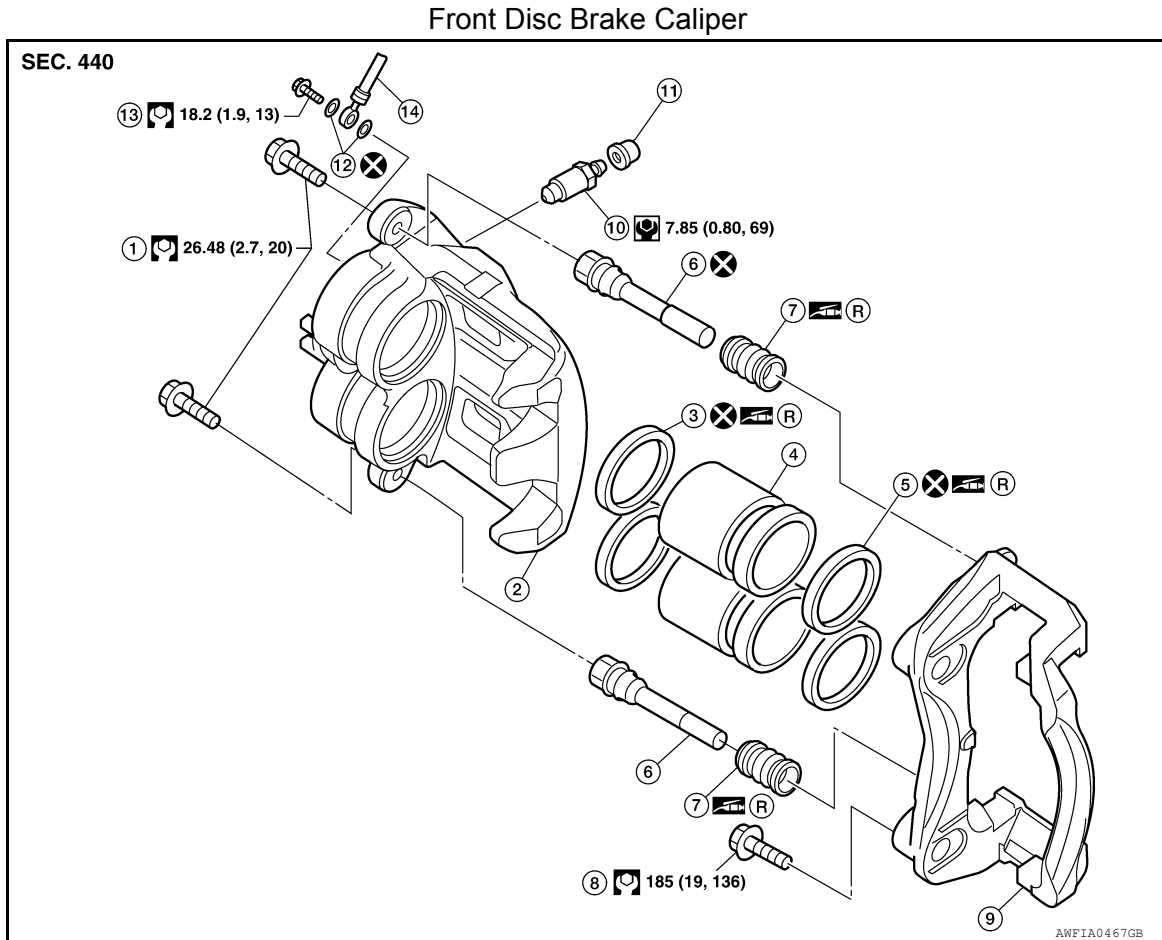

- |                     |                       |                            |
|---------------------|-----------------------|----------------------------|
| 1. Sliding pin bolt | 2. Caliper body       | 3. Piston seal             |
| 4. Piston           | 5. Piston boot        | 6. Sliding pin             |
| 7. Sliding pin boot | 8. Torque member bolt | 9. Torque member           |
| 10. Bleed valve     | 11. Cap               | 12. Copper sealing washers |
| 13. Union bolt      | 14. Front brake hose  | R. Rubber grease           |

### WARNING:

Clean dust on caliper and brake pad with a vacuum dust collector to minimize the hazard of airborne particles or other materials.

### CAUTION:

- While removing caliper body never depress brake pedal because piston will pop out.
- It is not necessary to remove bolts on torque member and brake hose except for disassembly or replacement of caliper body. In this case, hang caliper body with a wire so as not to stretch the brake hose.
- Do not damage the piston boot.
- If any shim is subject to serious corrosion, replace it with a new one.
- Always replace shim and shim cover as a set when replacing brake pads.
- Keep rotor free from grease and brake fluid.
- Burnish the brake contact surface after refinishing or replacing rotors, after replacing pads, or if a soft pedal occurs at very low mileage. Refer to [BR-41, "Brake Burnishing"](#).

## Removal and Installation of Brake Caliper and Disc Rotor

INFOID:000000007356631

### REMOVAL

1. Remove the front wheel and tire. Refer to [WT-50, "Adjustment"](#).
2. Remove master cylinder reservoir cap.

## FRONT DISC BRAKE

### < REMOVAL AND INSTALLATION >

3. Remove the union bolt then disconnect the brake hose and discard the copper sealing washers.

**CAUTION:**

**Do not reuse copper sealing washers.**

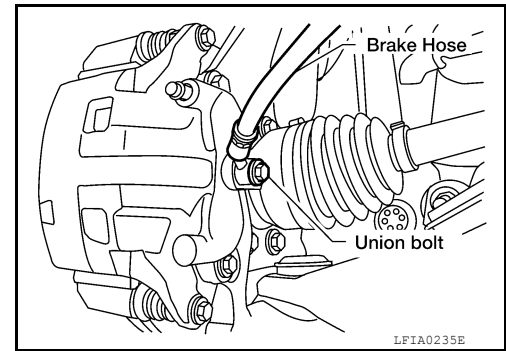

4. Remove the sliding pin bolts and remove the caliper body from the torque member.

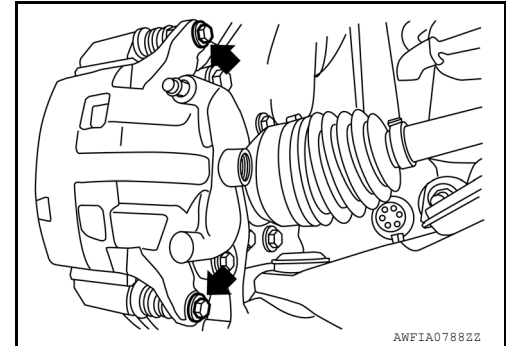

5. Remove the brake pads, shims, shim covers and retainers from the torque member.
6. Remove the torque member bolts and remove the torque member.
7. Remove the disc rotor. If reusing the disc rotor, apply a matching mark as shown for installation.

**CAUTION:**

**Put matching marks on the wheel hub assembly and disc rotor, if reusing the disc rotor.**

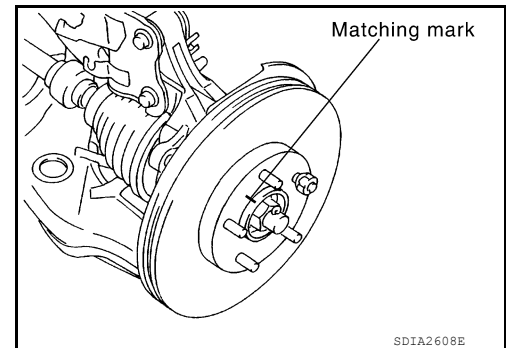

### INSTALLATION

1. Install the disc rotor. If reusing the disc rotor, align the matching marks as shown for installation.

**CAUTION:**

**Align the matching marks on the wheel hub assembly and disc rotor, if reusing the disc rotor.**

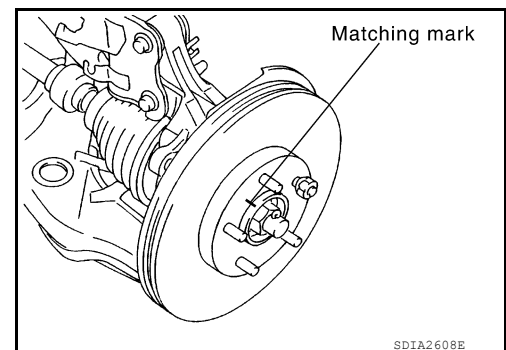

2. Install torque member and tighten the torque member bolts to specification. Refer to [BR-42. "Exploded View of Brake Caliper"](#).
3. Install the brake pads, shims, shim covers and retainers on the torque member. Refer to [BR-39. "Exploded View of Brake Pads"](#).

## FRONT DISC BRAKE

### < REMOVAL AND INSTALLATION >

4. Install caliper body and sliding pins, then tighten the sliding pin bolts to the specified torque. Refer to [BR-42, "Exploded View of Brake Caliper"](#).

**CAUTION:**

When installing the caliper body to the torque member, wipe any oil off of the torque member, washers and caliper body attachment surfaces.

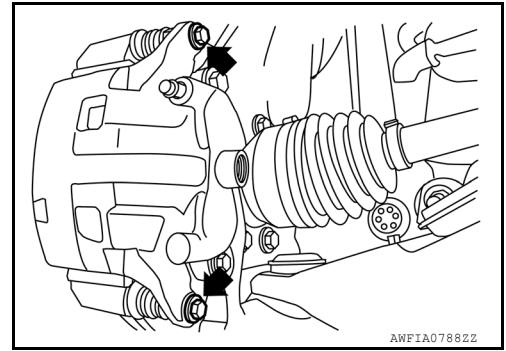

5. Install brake hose by aligning with the protrusion on caliper body, then install new copper sealing washers (1) and union bolt (A). Tighten union bolt (A) to specified torque. Refer to [BR-26, "Hydraulic Circuit"](#).

**CAUTION:**

Do not reuse copper sealing washers.

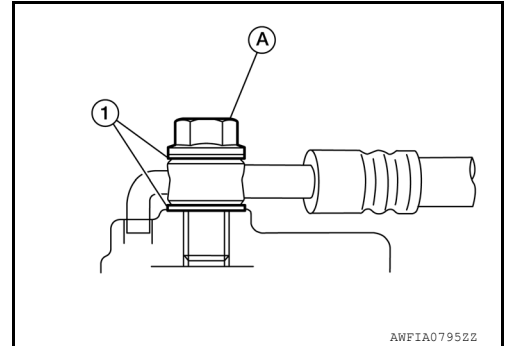

6. Refill with new brake fluid as necessary and bleed the brake system. Refer to [BR-20, "Bleeding Brake System"](#).

**CAUTION:**

- Refill with new brake fluid.
- Do not reuse drained brake fluid.

7. Install the front wheel and tire. Refer to [WT-50, "Adjustment"](#).

# REAR DISC BRAKE

< REMOVAL AND INSTALLATION >

## REAR DISC BRAKE

### Exploded View of Brake Pad

INFOID:000000007356632

Rear Brake Pads, Shims and Retainers

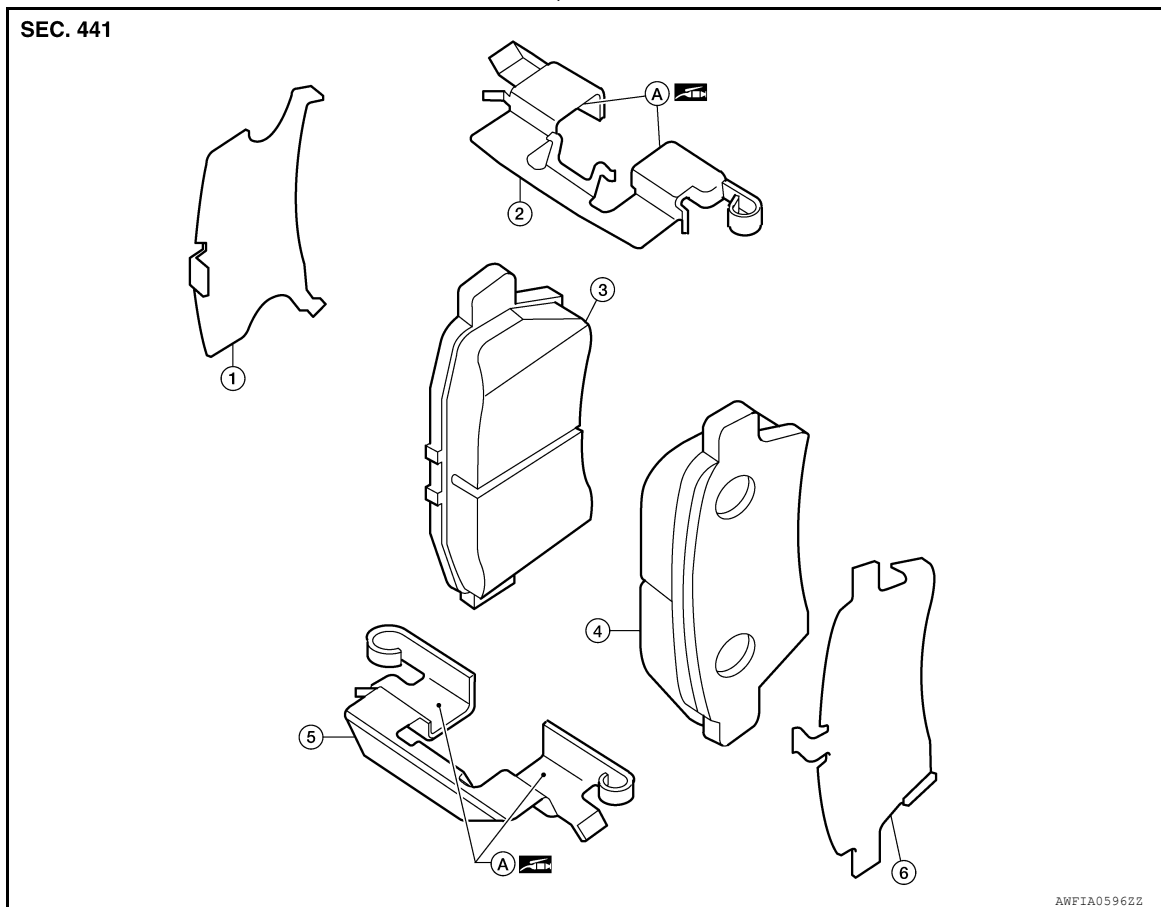

- |                         |                       |                    |
|-------------------------|-----------------------|--------------------|
| 1. Inner shim           | 2. Upper pad retainer | 3. Inner brake pad |
| 4. Outer brake pad      | 5. Lower pad retainer | 6. Outer shim      |
| A. Molykote 7439 grease |                       |                    |

#### WARNING:

Clean dust on caliper and brake pad with a vacuum dust collector to minimize the hazard of airborne particles or other materials.

#### CAUTION:

- While removing brake pads never depress brake pedal because piston will pop out.
- It is not necessary to remove bolts on torque member and brake hose except for disassembly or replacement of caliper body. In this case, hang caliper body with a wire so as not to stretch the brake hose.
- Do not damage the piston boot.
- If any shim is subject to serious corrosion, replace it with a new one.
- Always replace inner and outer shims as a set when replacing brake pads.
- Keep rotor free from grease and brake fluid.
- Burnish the brake contact surface after refinishing or replacing rotors, after replacing pads, or if a soft pedal occurs at very low mileage. Refer to [BR-46, "Brake Burnishing"](#).

### Removal and Installation of Brake Pad

INFOID:000000007356633

#### REMOVAL

1. Remove the rear wheel and tire. Refer to [WT-50, "Adjustment"](#).
2. Remove master cylinder reservoir cap.

A  
B  
C  
D  
E  
BR  
G  
H  
I  
J  
K  
L  
M  
N  
O  
P

# REAR DISC BRAKE

## < REMOVAL AND INSTALLATION >

3. Partially drain the brake fluid. Refer to [BR-20, "Drain and Refill"](#).
4. Remove lower sliding pin bolt using power tool and swing the caliper body up to access the brake pads.
5. Support the caliper body with a suitable wire to avoid pulling on the rear brake hose.
6. Remove the rear inner and outer brake pads, shims and retainers from the torque member.

## INSTALLATION

1. Attach shims to the brake pads.
2. Apply Molykote 7439 grease (A) to the pad retainers as shown.

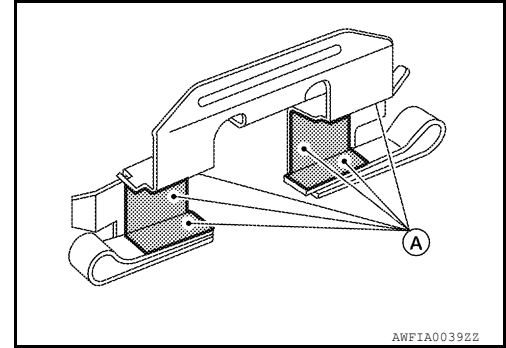

3. Attach pad retainer to torque member, then install brake pad and shim assemblies.

### **CAUTION:**

**When attaching pad retainer, attach it firmly so that it is flush with torque member, as shown.**

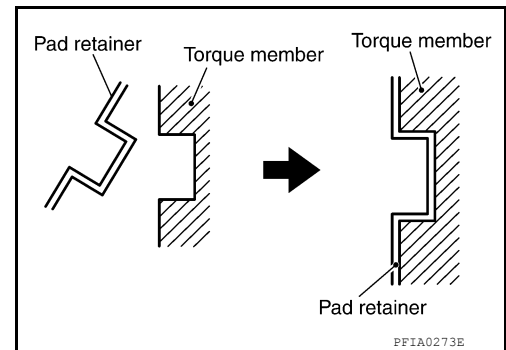

4. Using a suitable tool push piston into caliper body.  
**CAUTION:**  
**By pushing in piston, brake fluid returns to master cylinder reservoir tank. Watch the level of the brake fluid in the reservoir tank.**
5. Remove the suitable wire then swing the caliper body down over the brake pad assemblies.
6. Install the lower sliding pin bolt and tighten to specification. Refer to [BR-47, "Exploded View of Brake Caliper"](#).
7. Check the brakes for drag.
8. Inspect the brake fluid level and refill if necessary. Refer to [BR-20, "Drain and Refill"](#).
9. Install the rear wheel and tire. Refer to [WT-50, "Adjustment"](#).

## Brake Burnishing

INFOID:000000007356634

Burnish brake contact surface according to the following procedure after refinishing or replacing rotors, after replacing pads, or if a soft pedal occurs at very low mileage.

### **CAUTION:**

**Only perform this procedure under safe road and traffic conditions. Use extreme caution.**

1. Drive the vehicle on a straight smooth road at 50 km/h (31 MPH).
2. Use medium brake pedal/foot effort to bring the vehicle to a complete stop from 50 km/h (31 MPH). Adjust brake pedal/foot pressure such that vehicle stopping time equals 3 to 5 seconds.
3. To cool brake system, drive the vehicle at 50 km/h (31 MPH) for 1 minute without stopping.
4. Repeat steps 1 to 3, 10 times or more to complete the burnishing procedure.

# REAR DISC BRAKE

< REMOVAL AND INSTALLATION >

## Exploded View of Brake Caliper

INFOID:000000007356635

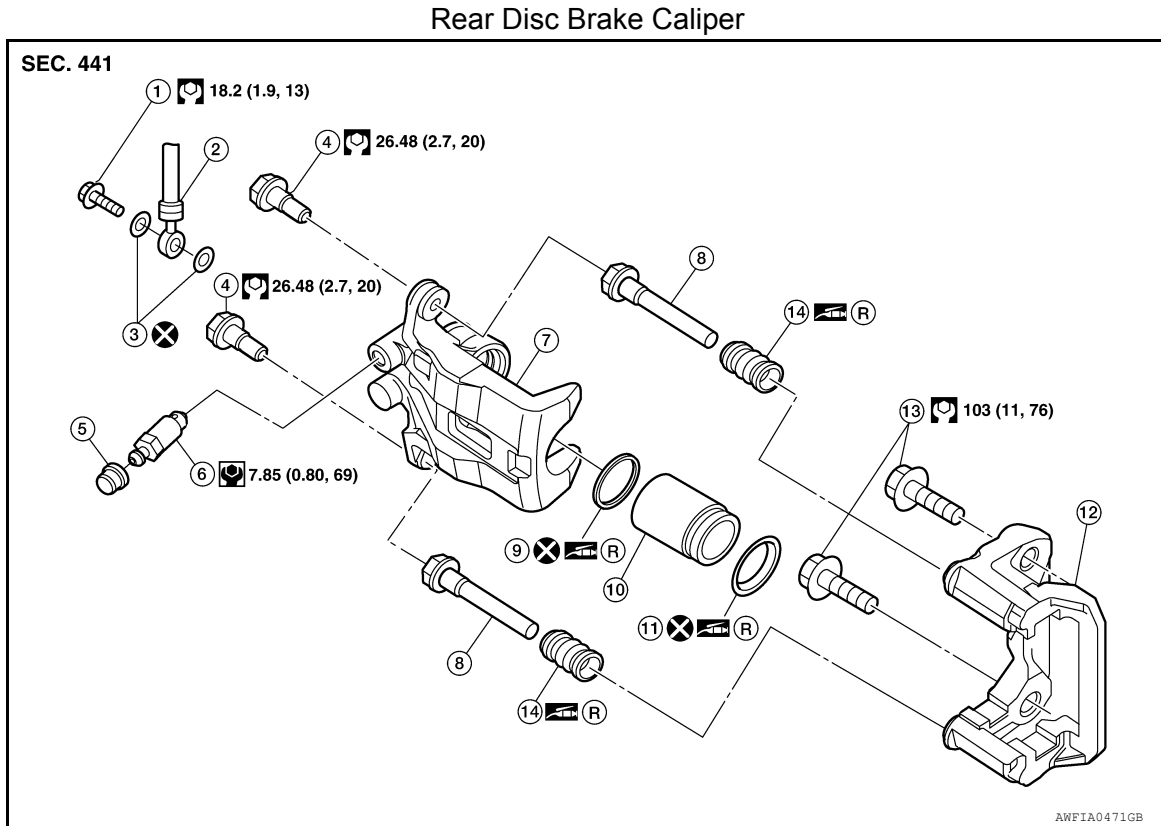

- |                        |                      |                           |
|------------------------|----------------------|---------------------------|
| 1. Union bolt          | 2. Brake hose        | 3. Copper sealing washers |
| 4. Sliding pin bolt    | 5. Cap               | 6. Bleed valve            |
| 7. Caliper body        | 8. Sliding pin       | 9. Piston seal            |
| 10. Piston             | 11. Piston boot      | 12. Torque member         |
| 13. Torque member bolt | 14. Sliding pin boot | R. Rubber grease          |

### WARNING:

Clean dust on caliper and brake pad with a vacuum dust collector to minimize the hazard of airborne particles or other materials.

### CAUTION:

- While removing caliper body never depress brake pedal because piston will pop out.
- It is not necessary to remove bolts on torque member and brake hose except for disassembly or replacement of caliper body. In this case, hang caliper body with a wire so as not to stretch the brake hose.
- Do not damage the piston boot.
- If any shim is subject to serious corrosion, replace it with a new one.
- Always replace shim and shim cover as a set when replacing brake pads.
- Keep rotor free from grease and brake fluid.
- Burnish the brake contact surface after refinishing or replacing rotors, after replacing pads, or if a soft pedal occurs at very low mileage. Refer to [BR-46, "Brake Burnishing"](#).

## Removal and Installation of Brake Caliper and Disc Rotor

INFOID:000000007356636

### REMOVAL

1. Remove the rear wheel and tire. Refer to [WT-50, "Adjustment"](#).
2. Remove master cylinder reservoir cap.

## REAR DISC BRAKE

### < REMOVAL AND INSTALLATION >

3. Remove the union bolt then disconnect the brake hose and discard the copper sealing washers.  
**CAUTION:**  
**Do not reuse copper sealing washers.**
4. Remove the sliding pin bolts and remove the caliper body from torque member.

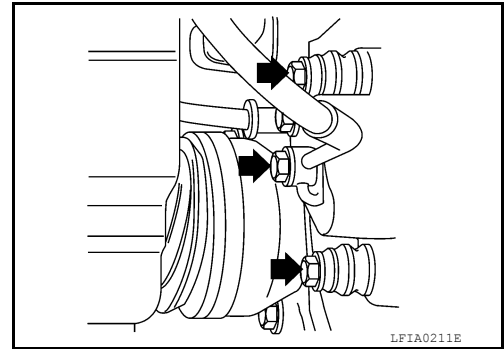

5. Remove the brake pads, shims and retainers from the torque member.
6. Remove the torque member bolts and remove the torque member.
7. Remove the disc rotor. If reusing the disc rotor, apply a matching mark as shown for installation.

**CAUTION:**  
**Put matching marks on the wheel hub assembly and disc rotor, if reusing the disc rotor.**

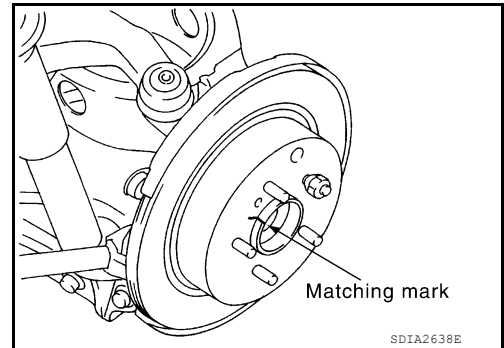

### INSTALLATION

1. Install the disc rotor. If reusing the disc rotor, align the matching marks as shown for installation.  
**CAUTION:**  
**Align the matching marks on the wheel hub assembly and disc rotor, if reusing the disc rotor.**

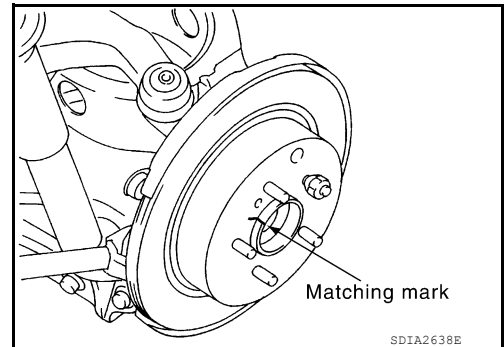

2. Install torque member and tighten the torque member bolts to specification. Refer to [BR-47, "Exploded View of Brake Caliper"](#).
3. Install the brake pads, shims and retainers on the torque member. Refer to [BR-45, "Exploded View of Brake Pad"](#).
4. Install caliper body and sliding pins, then tighten the sliding pin bolts to the specified torque. Refer to [BR-47, "Exploded View of Brake Caliper"](#).

**CAUTION:**  
**When installing the caliper body to the torque member, wipe any oil off of the knuckle spindle, washers and caliper body attachment surfaces.**



## REAR DISC BRAKE

### < REMOVAL AND INSTALLATION >

5. Install brake hose by aligning with the protrusion on caliper body, then install new copper sealing washers (1) and union bolt (A). Tighten union bolt (A) to specified torque. Refer to [BR-26. "Hydraulic Circuit"](#).

**CAUTION:**

**Do not reuse copper sealing washers.**

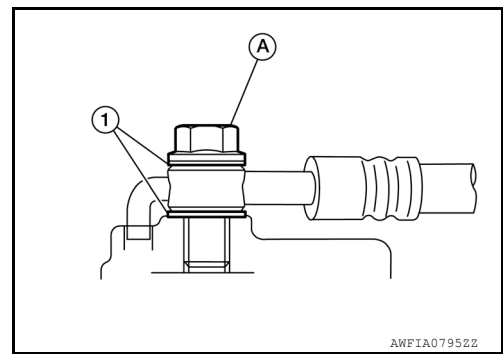

6. Refill with new brake fluid as necessary and bleed the brake system. Refer to [BR-20. "Bleeding Brake System"](#).

**CAUTION:**

- Refill with new brake fluid.
- Do not reuse drained brake fluid.

7. Install the rear wheel and tire. Refer to [WT-50. "Adjustment"](#).

A

B

C

D

E

BR

G

H

I

J

K

L

M

N

O

P

# BRAKE MASTER CYLINDER

< UNIT DISASSEMBLY AND ASSEMBLY >

## UNIT DISASSEMBLY AND ASSEMBLY

### BRAKE MASTER CYLINDER

Disassembly and Assembly

INFOID:000000007356637

VQ40DE MODELS

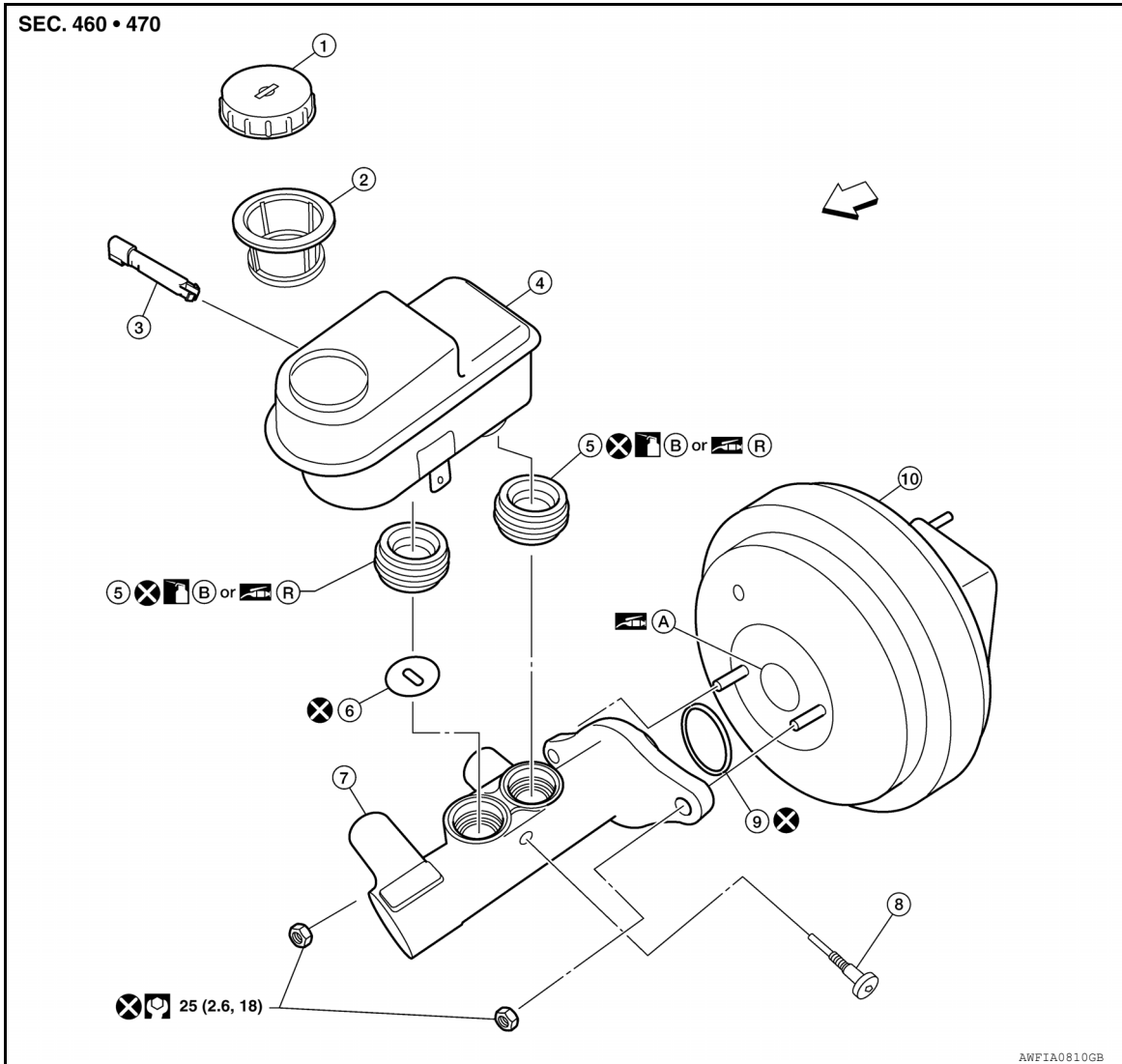

- |                                 |  |                       |
|---------------------------------|--|-----------------------|
| 1. Reservoir cap                | 2. Strainer  | 3. Fluid level sensor |
| 4. Reservoir tank               | 5. Grommet   | 6. Restriction washer |
| 7. Master cylinder sub-assembly | 8. Pin   | 9. O-ring             |
| 10. Brake booster               | A. PBC (Poly Butyl Cuprysil) grease or silicone based grease | B. Brake fluid        |
| R. Rubber grease                | ↔ Front  |                       |

VK56DE MODELS

# BRAKE MASTER CYLINDER

< UNIT DISASSEMBLY AND ASSEMBLY >

VK56DE

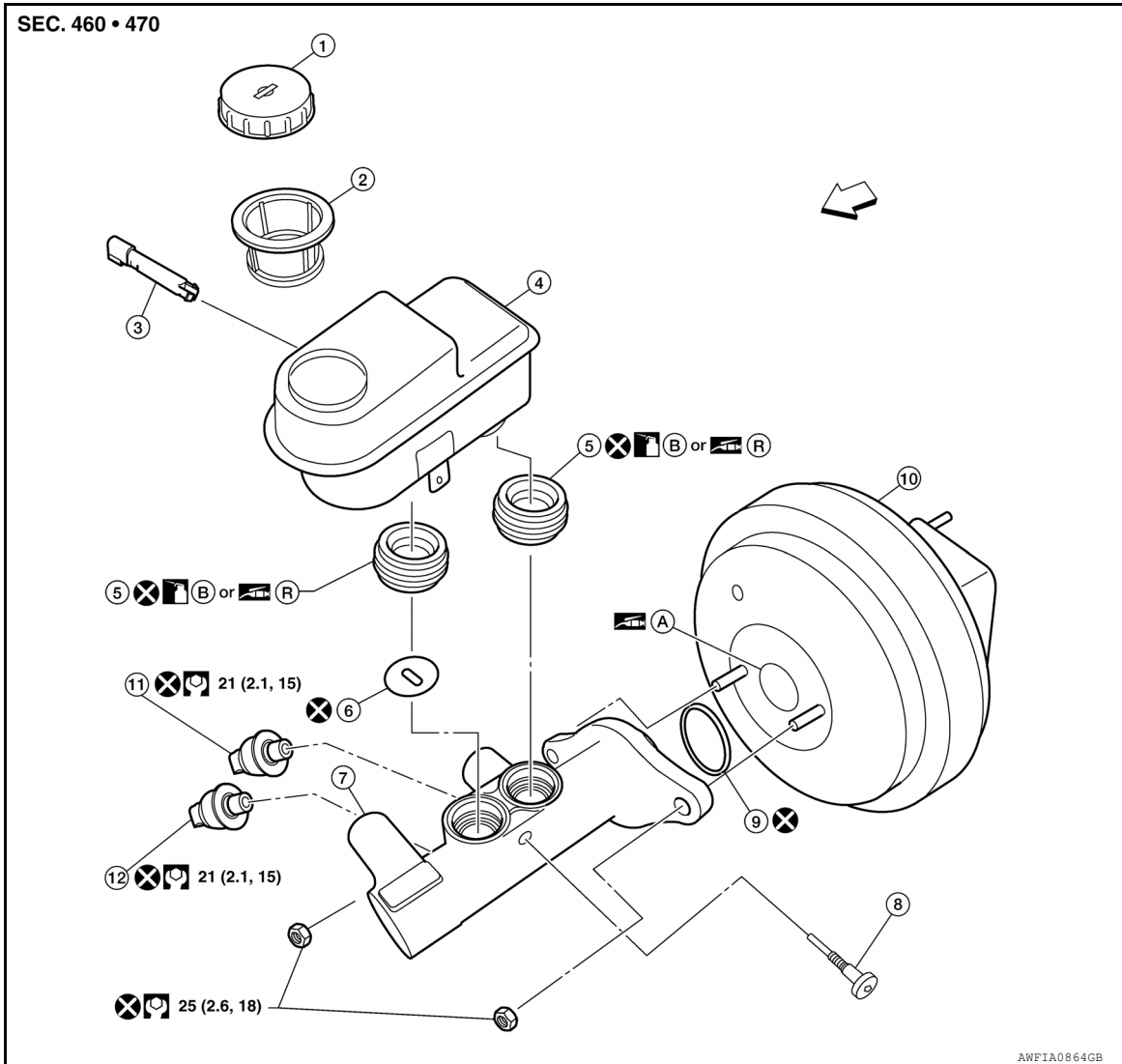

- |  |                           |                          |
|--|---------------------------|--------------------------|
| 1. Reservoir cap   | 2. Strainer               | 3. Fluid level sensor    |
| 4. Reservoir tank  | 5. Grommet                | 6. Restriction washer    |
| 7. Master cylinder sub-assembly                                    | 8. Pin                    | 9. O-ring                |
| 10. Brake booster  | 11. Front pressure sensor | 12. Rear pressure sensor |
| A. PBC (Poly Butyl Cuprysil)<br>grease or silicone based<br>grease | B. Brake fluid            | R. Rubber grease         |

← Front

## DISASSEMBLY

### CAUTION:

- Master cylinder sub-assembly cannot be disassembled.
- Remove reservoir tank only when absolutely necessary.
- While working, cover the primary piston rod with a cloth to prevent it from being damaged.
- Never use mineral oils such as kerosene, gasoline during the cleaning and assembly process.
- Do not drop parts. If a part is dropped, do not use it.

# BRAKE MASTER CYLINDER

## < UNIT DISASSEMBLY AND ASSEMBLY >

1. Secure the flange of the master cylinder sub-assembly in a vise.

**CAUTION:**

- Use copper plates or a cloth to cover the flange before securing it in the vise.
- When securing the master cylinder sub-assembly in a vise, be sure not to over-tighten the vise.

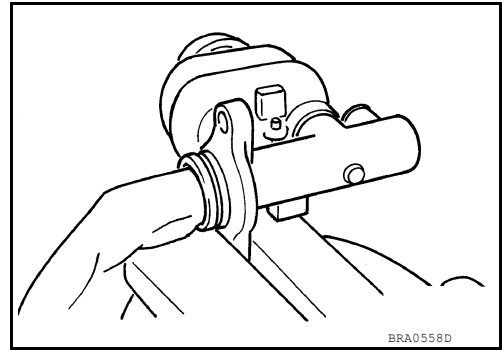

2. Remove the pin and pull the reservoir tank off of the master cylinder sub-assembly.

3. Remove the grommets from the master cylinder sub-assembly body.

**CAUTION:**

**Do not reuse grommets.**

4. Remove the restriction washer from the master cylinder sub-assembly body.

**CAUTION:**

**Do not reuse restriction washer.**

5. Remove the fluid level sensor.

6. Remove the fluid pressure sensors (if equipped).

**CAUTION:**

**Do not reuse fluid pressure sensors.**

## ASSEMBLY

Assembly is in the reverse order of disassembly.

**CAUTION:**

- Master cylinder sub-assembly cannot be disassembled.
- Remove reservoir tank only when absolutely necessary.
- While working, cover the primary piston rod with a cloth to prevent it from being damaged.
- Never use mineral oils such as kerosene, gasoline during the cleaning and assembly process.
- Do not drop parts. If a part is dropped, do not use it.

# FRONT DISC BRAKE

< UNIT DISASSEMBLY AND ASSEMBLY >

## FRONT DISC BRAKE

### Exploded View of Brake Caliper

INFOID:000000007356638

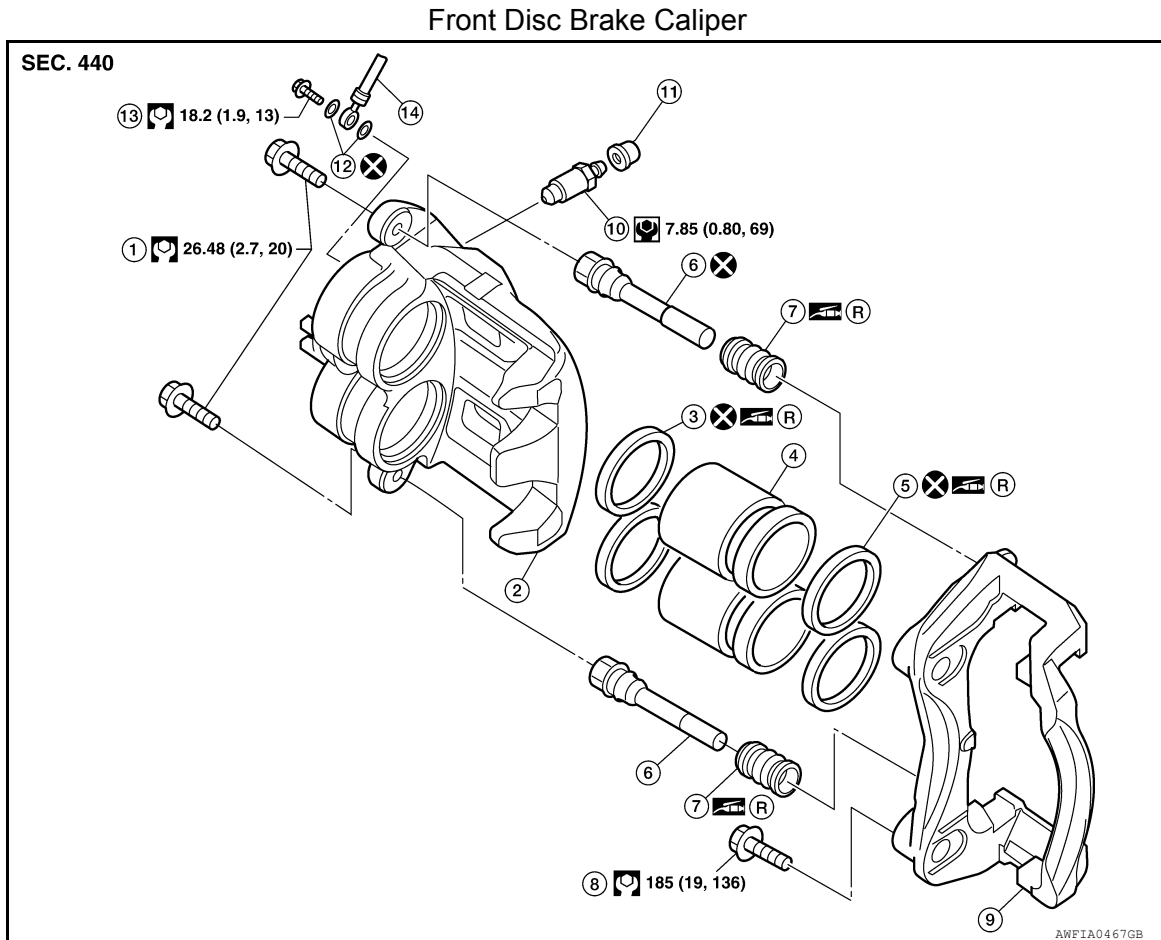

- |                     |                       |                            |
|---------------------|-----------------------|----------------------------|
| 1. Sliding pin bolt | 2. Caliper body       | 3. Piston seal             |
| 4. Piston           | 5. Piston boot        | 6. Sliding pin             |
| 7. Sliding pin boot | 8. Torque member bolt | 9. Torque member           |
| 10. Bleed valve     | 11. Cap               | 12. Copper sealing washers |
| 13. Union bolt      | 14. Front brake hose  | R. Rubber grease           |

#### WARNING:

Clean dust on caliper and brake pad with a vacuum dust collector to minimize the hazard of airborne particles or other materials.

#### CAUTION:

- While removing caliper body never depress brake pedal because piston will pop out.
- It is not necessary to remove bolts on torque member and brake hose except for disassembly or replacement of caliper body. In this case, hang caliper body with a wire so as not to stretch the brake hose.
- Do not damage the piston boot.
- If any shim is subject to serious corrosion, replace it with a new one.
- Always replace shim and shim cover as a set when replacing brake pads.
- Keep rotor free from grease and brake fluid.
- Burnish the brake contact surface after refinishing or replacing rotors, after replacing pads, or if a soft pedal occurs at very low mileage. Refer to [BR-41, "Brake Burnishing"](#).

### Disassembly and Assembly

INFOID:000000007356639

#### DISASSEMBLY

# FRONT DISC BRAKE

## < UNIT DISASSEMBLY AND ASSEMBLY >

1. Remove the caliper body from the torque member. Refer to [BR-42, "Removal and Installation of Brake Caliper and Disc Rotor"](#).
2. Remove the upper sliding pin, lower sliding pin, and sliding pin boots from the torque member.
3. Place a wooden block as shown, and then blow air from the union bolt hole to remove the pistons and piston boots.

**WARNING:**

**Do not get your fingers caught between the pistons and wooden block.**

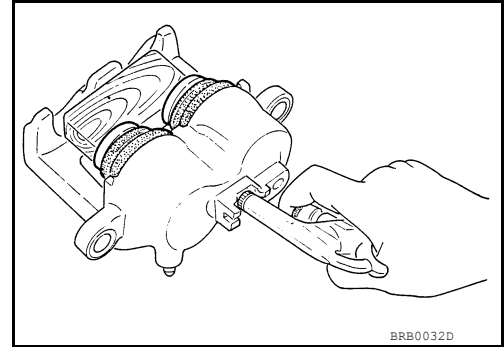

4. Remove the piston boots from the pistons.
5. Remove piston seals from cylinder body, using a suitable tool.

**CAUTION:**

**Do not reuse piston boot.**

**CAUTION:**

- Be careful not to damage cylinder body inner wall.
- Do not reuse piston seal.

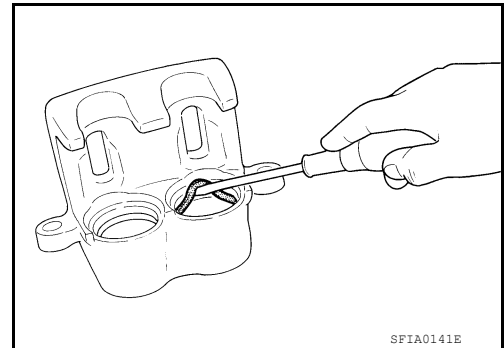

6. Remove the bleed valve and cap.

## CALIPER INSPECTION

### Cylinder Body

- Check the inside surface of the cylinder body for score, rust, wear, damage or foreign materials. If any of the above conditions are observed, replace the cylinder body.
- Minor damage from rust or foreign materials may be eliminated by polishing surface with a fine emery paper. Replace cylinder body if necessary.

**CAUTION:**

- Use new brake fluid for cleaning. Do not use mineral oils such as gasoline or kerosene.

### Torque Member

Check the torque member for wear, cracks, and damage. If damage or deformation is present, replace the torque member.

### Piston

Check the pistons for score, rust, wear, damage or presence of foreign materials. Replace if any of these conditions are observed.

**CAUTION:**

**Piston sliding surface is plated, do not polish with emery paper even if rust or foreign materials are stuck to sliding surface.**

### Sliding Pins, and Sliding Pin Boots

Check the sliding pins and sliding pin boots for wear, damage, and cracks. If damage or deformation is present, replace the affected part.

## ASSEMBLY

**CAUTION:**

**Use NISSAN Rubber Grease when assembling.**

1. Install the bleed valve and cap.

## FRONT DISC BRAKE

### < UNIT DISASSEMBLY AND ASSEMBLY >

2. Apply rubber grease to the new piston seals (1) and insert the new piston seals (1) into the groove on the cylinder body.

**CAUTION:**

**Do not reuse piston seals.**

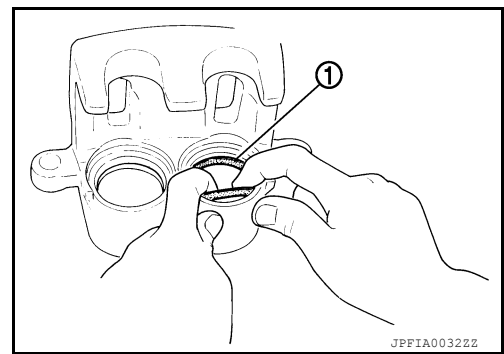

3. Apply rubber grease to the new piston boots (1). Cover the piston end (2) with the piston boot (1), and then install the cylinder side lip on the piston boot (1) securely into the groove on the cylinder body.

**CAUTION:**

- **Do not reuse piston boot.**
- **Press pistons in evenly and vary the pressing points to prevent the cylinder inner wall from being damaged.**

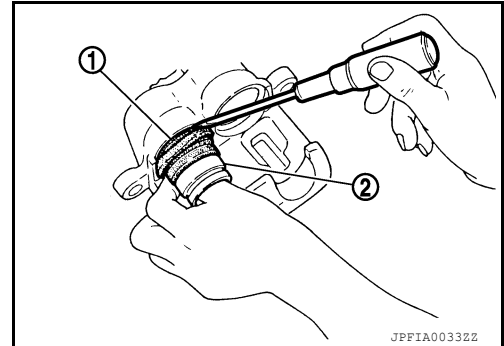

4. Install the pistons (1) into the cylinder body and insert the piston boots (2) side lip into the piston groove as shown.

**CAUTION:**

**Press pistons in evenly and vary the pressing points to prevent the cylinder inner wall from being damaged.**

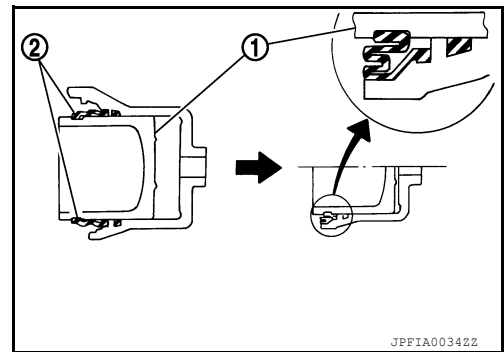

5. Apply rubber grease to the sliding pin boots, then install the new upper sliding pin, lower sliding pin, and sliding pin boots on the torque member.

**CAUTION:**

**Upper sliding pin must be replaced at each service.**

6. Install the cylinder body on the torque member. Refer to [BR-42, "Removal and Installation of Brake Caliper and Disc Rotor"](#).

# REAR DISC BRAKE

< UNIT DISASSEMBLY AND ASSEMBLY >

## REAR DISC BRAKE

### Exploded View of Brake Caliper

INFOID:000000007356640

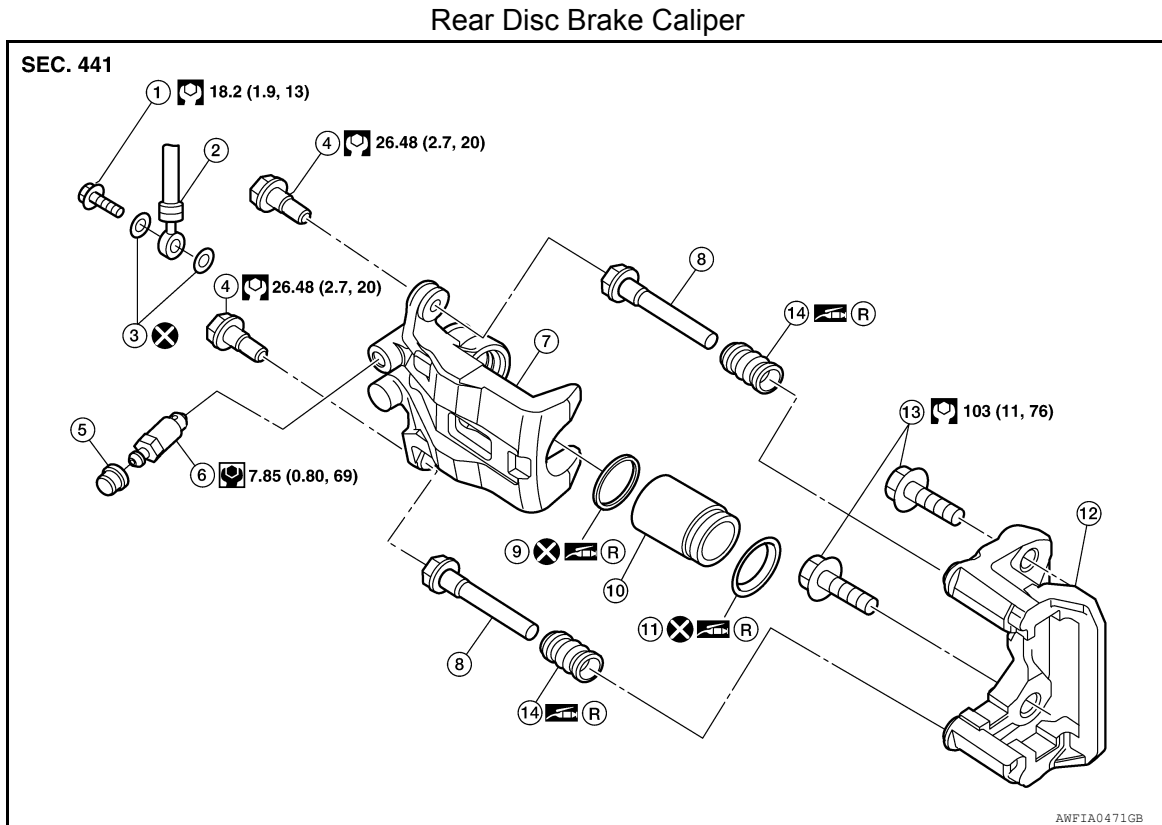

- |                        |                      |                           |
|------------------------|----------------------|---------------------------|
| 1. Union bolt          | 2. Brake hose        | 3. Copper sealing washers |
| 4. Sliding pin bolt    | 5. Cap               | 6. Bleed valve            |
| 7. Caliper body        | 8. Sliding pin       | 9. Piston seal            |
| 10. Piston             | 11. Piston boot      | 12. Torque member         |
| 13. Torque member bolt | 14. Sliding pin boot | R. Rubber grease          |

#### **WARNING:**

Clean dust on caliper and brake pad with a vacuum dust collector to minimize the hazard of airborne particles or other materials.

#### **CAUTION:**

- While removing caliper body never depress brake pedal because piston will pop out.
- It is not necessary to remove bolts on torque member and brake hose except for disassembly or replacement of caliper body. In this case, hang caliper body with a wire so as not to stretch the brake hose.
- Do not damage the piston boot.
- If any shim is subject to serious corrosion, replace it with a new one.
- Always replace shim and shim cover as a set when replacing brake pads.
- Keep rotor free from grease and brake fluid.
- Burnish the brake contact surface after refinishing or replacing rotors, after replacing pads, or if a soft pedal occurs at very low mileage. Refer to [BR-46, "Brake Burnishing"](#).

### Disassembly and Assembly

INFOID:000000007356641

#### DISASSEMBLY

1. Remove the cylinder body. Refer to [BR-47, "Removal and Installation of Brake Caliper and Disc Rotor"](#).
2. Remove the sliding pins and boots from the torque member.



## REAR DISC BRAKE

### < UNIT DISASSEMBLY AND ASSEMBLY >

- Place a wooden block in the cylinder body and blow air into the union bolt hole to remove the piston and piston boot as shown.

**WARNING:**

**Do not get your fingers caught between the piston and wooden block.**

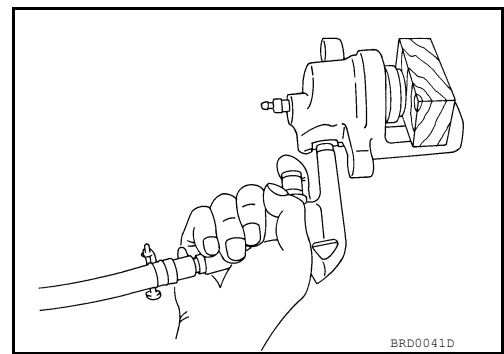

- Remove the piston boot from the piston.  
**CAUTION:**  
**Do not reuse piston boot.**
- Remove piston seal from cylinder body, using a suitable tool.  
**CAUTION:**  
**Be careful not to damage cylinder body inner wall.**

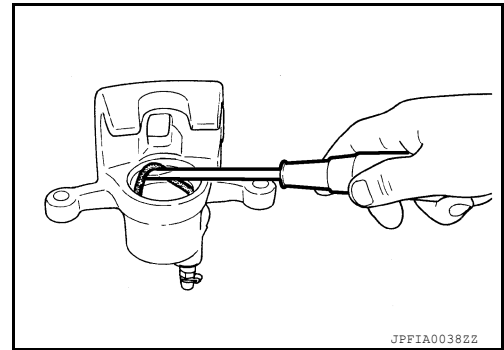

- Remove the bleed valve and cap.

### CALIPER INSPECTION

#### Cylinder Body

- Check inside surface of cylinder for score, rust wear, damage or foreign materials. If any of the above conditions are observed, replace cylinder body.
- Minor damage from rust or foreign materials may be eliminated by polishing surface with a fine emery paper. Replace cylinder body if necessary.

**CAUTION:**

- Use new brake fluid for cleaning. Do not use mineral oils such as gasoline or kerosene.**

#### Torque Member

Check the torque member for wear, cracks, and damage. If damage or deformation is present, replace the torque member.

#### Piston

Check the piston for score, rust, wear, damage or presence of foreign materials. Replace if any of the above conditions are observed.

**CAUTION:**

**Piston sliding surface is plated, do not polish with emery paper even if rust or foreign materials are stuck to sliding surface.**

#### Sliding Pin Bolts and Sliding Pin Boots

Check the sliding pins and sliding pin boots for wear, damage, and cracks. If damage or deformation is present, replace the affected part.

### ASSEMBLY

**CAUTION:**

**Use NISSAN Rubber Grease when assembling.**

- Install the bleed valve and cap.

A  
B  
C  
D  
E  
BR  
G  
H  
I  
J  
K  
L  
M  
N  
O  
P

## REAR DISC BRAKE

### < UNIT DISASSEMBLY AND ASSEMBLY >

2. Apply rubber grease to the new piston seal (1) and insert the new piston seal (1) into the groove on the cylinder body.

**CAUTION:**

**Do not reuse piston seal.**

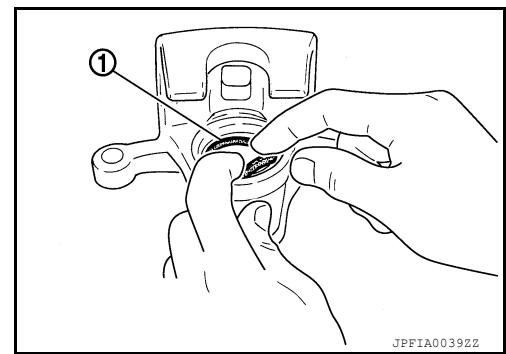

3. Apply rubber grease to the new piston boot (1). Cover the piston end (2) with the piston boot (1), and then install the cylinder side lip on the piston boot (1) securely into the groove on the cylinder body.

**CAUTION:**

- Do not reuse piston boot.
- Press pistons in evenly and vary the pressing points to prevent the cylinder inner wall from being damaged.

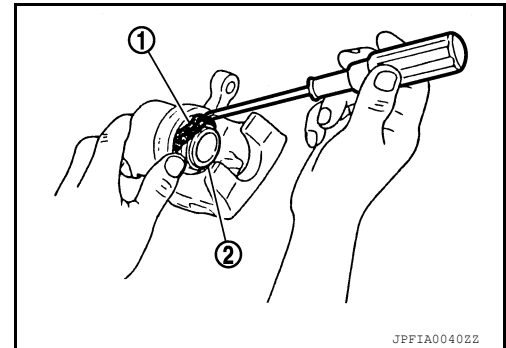

4. Install the piston (1) into the cylinder body and insert the piston boot (2) side lip into the piston groove as shown.

**CAUTION:**

**Press pistons in evenly and vary the pressing points to prevent the cylinder inner wall from being damaged.**

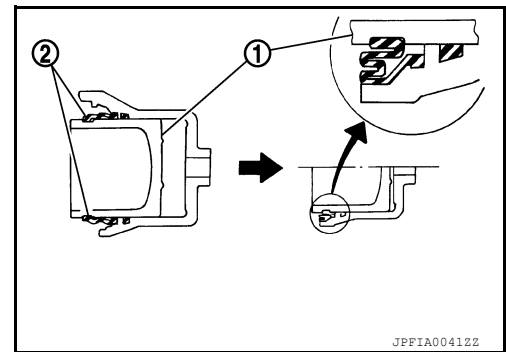

5. Apply rubber grease to the sliding pin boots, then install the sliding pins and sliding pin boots on the torque member.
6. Install the cylinder body on the torque member. Refer to [BR-47, "Removal and Installation of Brake Caliper and Disc Rotor"](#).

# SERVICE DATA AND SPECIFICATIONS (SDS)

< SERVICE DATA AND SPECIFICATIONS (SDS)

## SERVICE DATA AND SPECIFICATIONS (SDS)

### SERVICE DATA AND SPECIFICATIONS (SDS)

#### General Specification

INFOID:000000007356642

Unit: mm (in)

Application		VQ40DE	VK56DE
Front brake	Brake model	CLZ33VB	
	Rotor outer diameter × thickness	296 × 28 (11.654 × 1.102)	320 × 28 (12.598 × 1.102)
	Pad Length × width × thickness	140 × 50.5 × 10.0 (5.512 × 1.988 × 0.394)	130 × 52.3 × 11.0 (5.118 × 2.059 × 0.433)
	Cylinder bore diameter (each)	46.4 (1.827)	45.0 (1.772)
Rear brake	Brake model	CLZ14VB	
	Rotor outer diameter × thickness	308 × 18 (12.126 × 0.709)	
	Pad Length × width × thickness	87.6 × 37.0 × 11.0 (3.449 × 1.457 × 0.433)	
	Cylinder bore diameter	38.1 (1.500)	
Control valve	Valve model	Electric brake force distribution	
Brake booster	Booster model	C215T	
	Diaphragm diameter	215 (8.465)	
Recommended brake fluid		Refer to <a href="#">MA-18, "FOR USA AND CANADA : Fluids and Lubricants"</a> (United States and Canada), <a href="#">MA-20, "FOR MEXICO : Fluids and Lubricants"</a> (Mexico).	

#### Brake Pedal

INFOID:000000007356643

#### ADJUSTABLE PEDAL

Unit: mm (in)

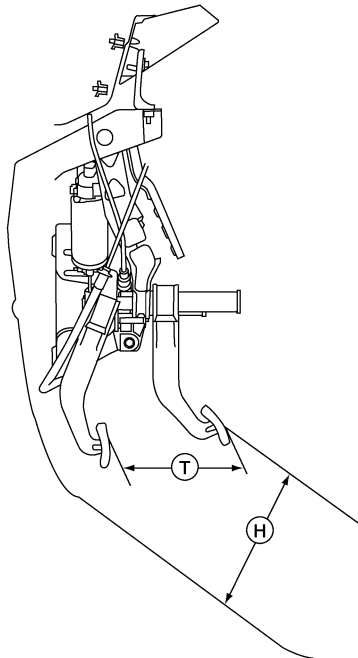

ALFIA01492Z

Pedal free height (H) with pedal in forward most position	182.1 (7.17)
Pedal full stroke (T)	153 (6.02)
Clearance between brake pedal bracket and threaded end of stop lamp switch and ASCD cancel switch	0.74 - 1.96 (0.029 - 0.077)

# SERVICE DATA AND SPECIFICATIONS (SDS)

## < SERVICE DATA AND SPECIFICATIONS (SDS)

**CAUTION:**

When equipped with adjustable pedal, the pedal must be in the forward most position (closest to the floor) for pedal height adjustment.

### STANDARD PEDAL

Unit: mm (in)

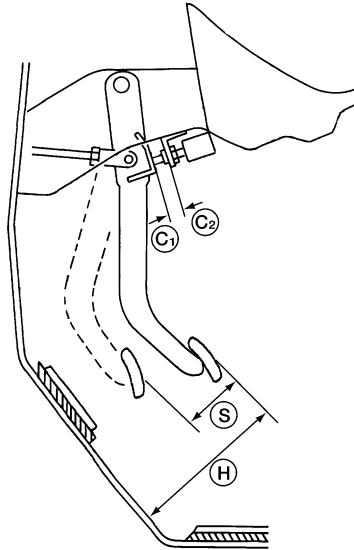

AWFIA04332Z

Pedal free height (H)	182.1 (7.17)
Pedal full stroke (S)	153 (6.02)
Clearance between brake pedal bracket (C1) and threaded end of stop lamp switch and ASCD cancel switch (C2)	0.74 - 1.96 (0.029 - 0.077)

### Brake Booster

INFOID:000000007356644

Unit: mm (in)

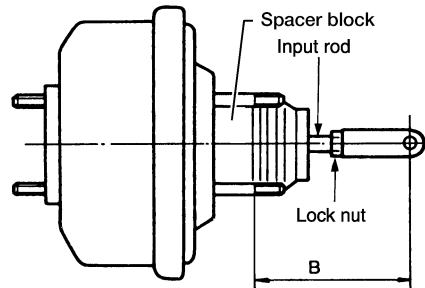

WFIA0382E

Input rod installation length (B)	145 - 152 (5.71 - 5.98)
-----------------------------------	-------------------------

### Check Valve

INFOID:000000007356645

Vacuum leakage [at vacuum of -66.7 kPa(-500 mmHg, -19.69 inHg)]	Within 1.3 kPa (10 mmHg, 0.39 inHg) of vacuum for 15 seconds
--	--

# SERVICE DATA AND SPECIFICATIONS (SDS)

## < SERVICE DATA AND SPECIFICATIONS (SDS)

### Front Disc Brake

INFOID:000000007356646

Unit: mm (in)

Brake model		CLZ33VB	
Application		VQ40DE	VQ56DE
Brake pad	Standard thickness (new)	10.0 (0.394)	11.0 (0.043)
	Minimum thickness	2.0 (0.079)	
Disc rotor	Standard thickness (new)	28.0 (1.102)	
	Minimum thickness	26.0 (1.024)	
	Maximum uneven wear (measured at 8 positions)	0.015 (0.0006)	
	Runout limit (with it attached to the vehicle)	0.05 (0.0020)	

### Rear Disc Brake

INFOID:000000007356647

Unit: mm (in)

Brake model		CLZ14VB	
Brake pad	Standard thickness (new)	11.0 (0.433)	
	Minimum thickness	2.0 (0.079)	
Disc rotor	Standard thickness (new)	18.0 (0.709)	
	Minimum thickness	16.0 (0.630)	
	Maximum uneven wear (measured at 8 positions)	0.015 (0.0006)	
	Runout limit (with it attached to the vehicle)	0.05 (0.0020)	