

SECTION **FAX**
FRONT AXLE

A
B
C

FAX

CONTENTS

E

PRECAUTION	2	VK56DE	8	F
PRECAUTIONS	2	VK56DE : Removal and Installation	8	
Precaution for Supplemental Restraint System (SRS) "AIR BAG" and "SEAT BELT PRE-TENSIONER"	2	WHEEL HUB	10	G
Precautions for Driveshaft	2	Removal and Installation	10	
Precaution Necessary for Steering Wheel Rotation After Battery Disconnect	2	UNIT DISASSEMBLY AND ASSEMBLY ...	12	H
PREPARATION	4	DRIVE SHAFT	12	
PREPARATION	4	VQ40DE	12	I
Special Service Tool	4	VQ40DE : Disassembly and Assembly	12	
Commercial Service Tool	4	VK56DE	16	J
SYMPTOM DIAGNOSIS	5	VK56DE : Disassembly and Assembly	17	
NOISE, VIBRATION, AND HARSHNESS (NVH) TROUBLESHOOTING	5	SERVICE DATA AND SPECIFICATIONS (SDS)	22	K
NVH Troubleshooting Chart	5	SERVICE DATA AND SPECIFICATIONS (SDS)	22	L
PERIODIC MAINTENANCE	6	VQ40DE	22	
WHEEL HUB	6	VQ40DE : Wheel Bearing	22	M
On-Vehicle Inspection and Service	6	VQ40DE : Drive Shaft	22	
UNIT REMOVAL AND INSTALLATION	7	VQ40DE : Boot Bands	22	
DRIVE SHAFT	7	VK56DE	22	N
VQ40DE	7	VK56DE : Wheel Bearing	22	
VQ40DE : Removal and Installation	7	VK56DE : Drive Shaft	23	O
		VK56DE : Boot Bands	23	

F

G

H

I

J

K

L

M

N

O

P

PRECAUTIONS

< PRECAUTION >

PRECAUTION

PRECAUTIONS

Precaution for Supplemental Restraint System (SRS) "AIR BAG" and "SEAT BELT PRE-TENSIONER"

INFOID:000000007357671

The Supplemental Restraint System such as "AIR BAG" and "SEAT BELT PRE-TENSIONER", used along with a front seat belt, helps to reduce the risk or severity of injury to the driver and front passenger for certain types of collision. This system includes seat belt switch inputs and dual stage front air bag modules. The SRS system uses the seat belt switches to determine the front air bag deployment, and may only deploy one front air bag, depending on the severity of a collision and whether the front occupants are belted or unbelted. Information necessary to service the system safely is included in the SR and SB section of this Service Manual.

WARNING:

- To avoid rendering the SRS inoperative, which could increase the risk of personal injury or death in the event of a collision which would result in air bag inflation, all maintenance must be performed by an authorized NISSAN/INFINITI dealer.
- Improper maintenance, including incorrect removal and installation of the SRS, can lead to personal injury caused by unintentional activation of the system. For removal of Spiral Cable and Air Bag Module, see the SR section.
- Do not use electrical test equipment on any circuit related to the SRS unless instructed to in this Service Manual. SRS wiring harnesses can be identified by yellow and/or orange harnesses or harness connectors.

PRECAUTIONS WHEN USING POWER TOOLS (AIR OR ELECTRIC) AND HAMMERS

WARNING:

- When working near the Airbag Diagnosis Sensor Unit or other Airbag System sensors with the Ignition ON or engine running, DO NOT use air or electric power tools or strike near the sensor(s) with a hammer. Heavy vibration could activate the sensor(s) and deploy the air bag(s), possibly causing serious injury.
- When using air or electric power tools or hammers, always switch the Ignition OFF, disconnect the battery, and wait at least 3 minutes before performing any service.

Precautions for Driveshaft

INFOID:000000007357672

Observe the following precautions when disassembling and servicing the wheel hub and drive shafts.

- Perform work in a location which is as dust-free as possible.
- Before disassembling and servicing, clean the outside of parts.
- Prevent the entry of foreign objects during disassembly and assembly.
- Disassembled parts must be carefully reassembled in the correct order. If work is interrupted, a clean cover must be placed over parts.
- Paper shop cloths must be used. Fabric shop cloths must not be used because of the possibility of lint adhering to parts.
- Disassembled parts (except for rubber parts) should be cleaned with a suitable solvent which shall be removed by blowing with air or wiping with paper shop cloths.

Precaution Necessary for Steering Wheel Rotation After Battery Disconnect

INFOID:000000007357673

NOTE:

- This Procedure is applied only to models with Intelligent Key system and NATS (NISSAN ANTI-THEFT SYSTEM).
- Remove and install all control units after disconnecting both battery cables with the ignition knob in the "LOCK" position.
- Always use CONSULT to perform self-diagnosis as a part of each function inspection after finishing work. If DTC is detected, perform trouble diagnosis according to self-diagnostic results.

For models equipped with the Intelligent Key system and NATS, an electrically controlled steering lock mechanism is adopted on the key cylinder.

For this reason, if the battery is disconnected or if the battery is discharged, the steering wheel will lock and steering wheel rotation will become impossible.

PRECAUTIONS

< PRECAUTION >

If steering wheel rotation is required when battery power is interrupted, follow the procedure below before starting the repair operation.

OPERATION PROCEDURE

1. Connect both battery cables.

NOTE:

Supply power using jumper cables if battery is discharged.

2. Use the Intelligent Key or mechanical key to turn the ignition switch to the "ACC" position. At this time, the steering lock will be released.
3. Disconnect both battery cables. The steering lock will remain released and the steering wheel can be rotated.
4. Perform the necessary repair operation.
5. When the repair work is completed, return the ignition switch to the "LOCK" position before connecting the battery cables. (At this time, the steering lock mechanism will engage.)
6. Perform a self-diagnosis check of all control units using CONSULT.

A

B

C

FAX

E

F

G

H

I

J

K

L

M

N

O

P

PREPARATION

< PREPARATION >

PREPARATION

PREPARATION

Special Service Tool

INFOID:000000007357674

The actual shapes of Kent-Moore tools may differ from those of special service tools illustrated here.

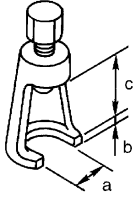
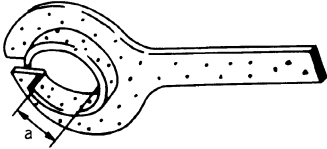
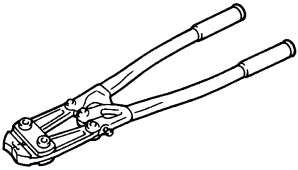
Tool number (Kent-Moore No.) Tool name	Description
ST29020001 (J-24319-01) Gear arm puller <div data-bbox="618 506 873 701" style="text-align: center;">  <p>NT694</p> </div>	Removing ball joint for steering knuckle a: 34 mm (1.34 in) b: 6.5 mm (0.256 in) c: 61.5 mm (2.421 in)
KV38105500 (J-33904) Protector <div data-bbox="610 779 935 953" style="text-align: center;">  <p>ZZA0835D</p> </div>	Installing drive shaft a: 32 mm (1.26 in) dia
KV40107300 (—) Boot band crimping tool <div data-bbox="626 1024 922 1205" style="text-align: center;">  <p>ZZA1229D</p> </div>	Installing boot bands

Commercial Service Tool

INFOID:000000007357675

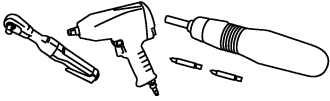
Tool name	Description
Power tools <div data-bbox="610 1457 938 1604" style="text-align: center;">  <p>PIIB1407E</p> </div>	Loosening nuts, screws and bolts

NOISE, VIBRATION, AND HARSHNESS (NVH) TROUBLESHOOTING

< SYMPTOM DIAGNOSIS >

SYMPTOM DIAGNOSIS

NOISE, VIBRATION, AND HARSHNESS (NVH) TROUBLESHOOTING

NVH Troubleshooting Chart

INFOID:000000007357676

Use the chart below to help you find the cause of the symptom. If necessary, repair or replace these parts.

Symptom		Possible cause and SUSPECTED PARTS											
		Excessive joint angle	Joint sliding resistance	Imbalance	Improper installation, looseness	Parts interference	Wheel bearing damage	PROPELLER SHAFT	FRONT FINAL DRIVE	SUSPENSION	TIRES	ROAD WHEEL	BRAKES
Symptom	Noise	x	x		x	x		x	x	x	x	x	x
	Shake	x		x	x	x		x		x	x	x	x
	Vibration	x	x	x	x	x		x		x			x
	Shimmy	x			x	x				x	x	x	x
	Shudder	x	x	x	x					x	x	x	x
	Poor quality ride or handling				x	x	x			x	x	x	

x: Applicable

A
B
C
FAX
E
F
G
H
I
J
K
L
M
N
O
P

WHEEL HUB

< PERIODIC MAINTENANCE >

PERIODIC MAINTENANCE

WHEEL HUB

On-Vehicle Inspection and Service

INFOID:000000007357677

Make sure the mounting conditions (looseness, backlash) of each component and component status (wear, damage) are normal.

WHEEL BEARING INSPECTION

- Move wheel hub in the axial direction by hand. Make sure there is no looseness of wheel bearing.

Axial end play limit : Refer to [FAX-22, "VQ40DE : Wheel Bearing" \(VQ40DE\)](#) or [FAX-22, "VK56DE : Wheel Bearing" \(VK56DE\)](#).

- Rotate wheel hub and make sure there is no unusual noise or other irregular conditions. If there are any irregular conditions, replace wheel hub and bearing assembly.

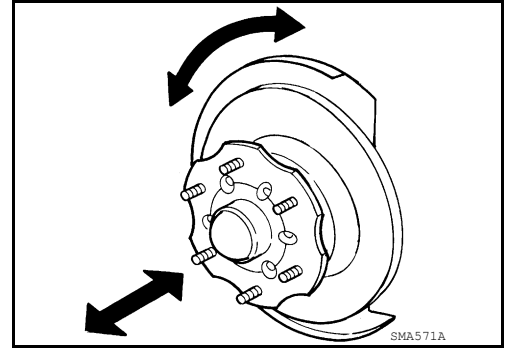

DRIVE SHAFT

< UNIT REMOVAL AND INSTALLATION >

UNIT REMOVAL AND INSTALLATION

DRIVE SHAFT

VQ40DE

VQ40DE : Removal and Installation

INFOID:000000007357678

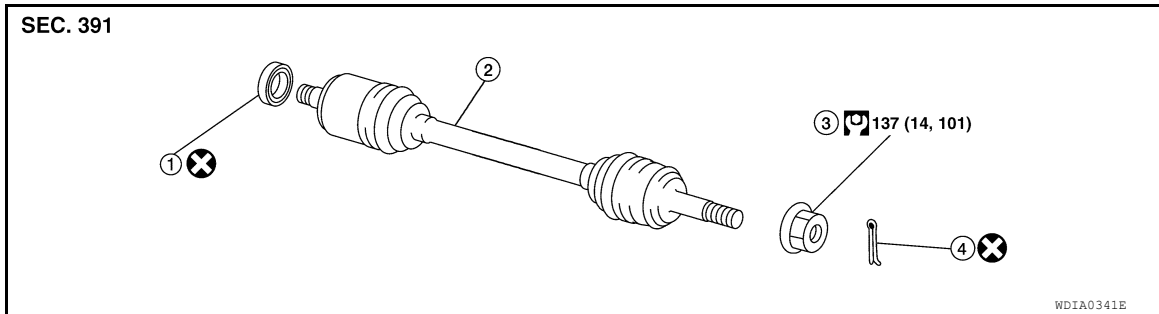

1. Differential side oil seal
2. Drive shaft
3. Drive shaft lock nut
4. Cotter pin

REMOVAL

1. Remove wheel and tire using power tool.
2. Remove rear engine under cover using power tool.
3. Remove wheel sensor harness from mount on knuckle, then disconnect wheel sensor harness connector.
CAUTION:
Do not pull on wheel sensor harness.
4. Remove wheel hub and bearing assembly. Refer to [FAX-10. "Removal and Installation"](#).
 - It is not necessary to remove wheel sensor from wheel hub when wheel hub is not being replaced.
 - Carefully feed wheel sensor harness through hole in splash shield.
5. Separate upper link ball joint stud from steering knuckle using Tool.
 - Support lower link with jack.

Tool number : [ST29020001 \(J-24319-01\)](#)

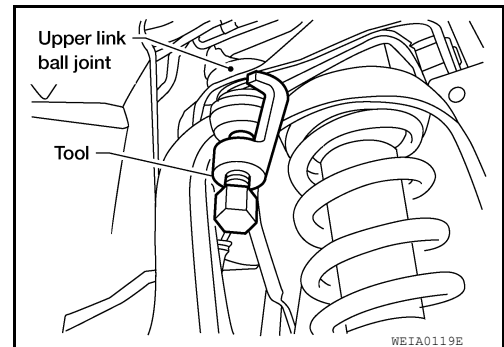

6. Remove drive shaft assembly.
 - Pry drive shaft front final drive using suitable tool.
 - Remove differential side oil seal. Refer to [DLN-355. "Removal and Installation"](#).
CAUTION:
 - **When removing drive shaft, do not apply an excessive angle to drive shaft joint. Also be careful not to excessively extend slide joint.**

INSPECTION AFTER REMOVAL

- Move joint up, down, left, right, and in axial direction. Check for any rough movement or significant looseness.

DRIVE SHAFT

< UNIT REMOVAL AND INSTALLATION >

- Check boot for cracks or other damage, and for grease leakage.
- If damaged, disassemble drive shaft to verify damage, and repair or replace as necessary.

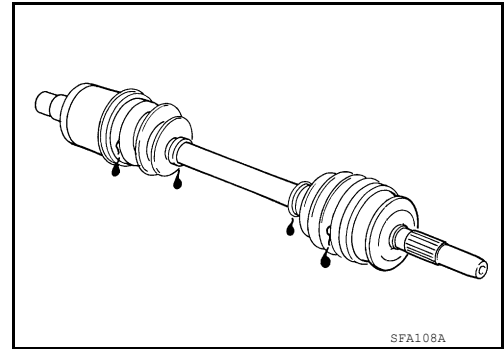

INSTALLATION

Installation is in the reverse order of removal.

- When installing drive shaft onto front final drive, use Tool to prevent damage to the oil seal while inserting drive shaft. Slide drive shaft sliding joint and tap with a hammer to install securely.

Tool number : KV38105500 (J-33904)

CAUTION:

Do not reuse the differential side oil seal.

- Tighten wheel nuts to specification. Refer to [WT-50, "Adjustment"](#).

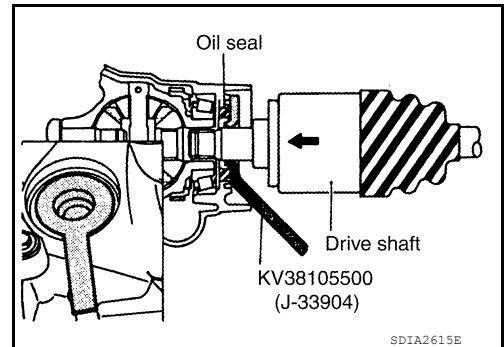

VK56DE

VK56DE : Removal and Installation

INFOID:000000007357679

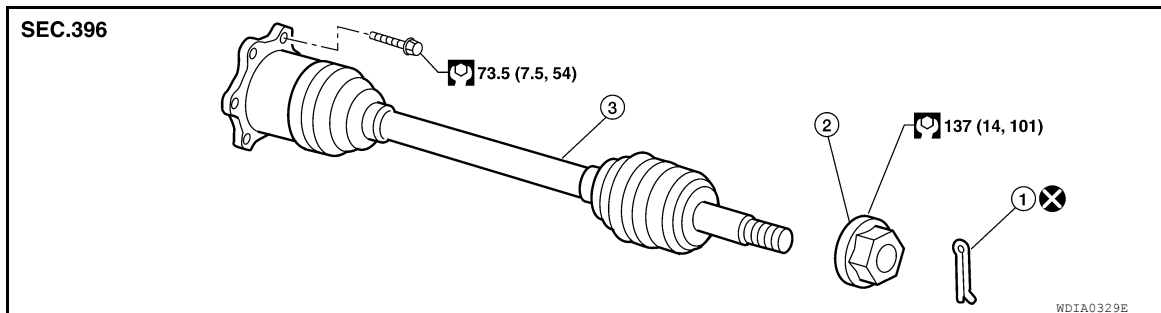

1. Cotter pin

2. Drive shaft nut

3. Drive shaft

REMOVAL

1. Remove wheel and tire using power tool.
2. Remove engine under cover using power tool.
3. Remove wheel sensor harness from mount on knuckle, then disconnect wheel sensor harness connector.

CAUTION:

Do not pull on wheel sensor harness.

4. Remove wheel hub and bearing assembly. Refer to [FAX-10, "Removal and Installation"](#).
 - It is not necessary to remove wheel sensor from wheel hub when wheel hub is not being replaced.
 - Carefully feed wheel sensor harness through hole in splash shield.

DRIVE SHAFT

< UNIT REMOVAL AND INSTALLATION >

5. Separate upper link ball joint stud from steering knuckle using Tool.
 - Support lower link with jack.

Tool number : ST29020001 (J-24319-01)

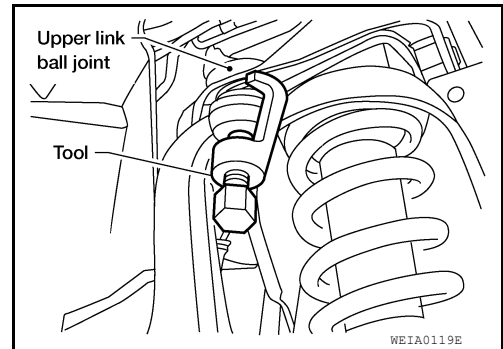

6. Remove drive shaft mounting bolts from front final drive.
7. Remove drive shaft assembly.

CAUTION:

- **When removing drive shaft, do not apply an excessive angle to drive shaft joint. Also be careful not to excessively extend slide joint.**

INSPECTION AFTER REMOVAL

- Move joint up, down, left, right, and in axial direction. Check for any rough movement or significant looseness.
- Check boot for cracks or other damage, and for grease leakage.
- If damaged, disassemble drive shaft to verify damage, and repair or replace as necessary.

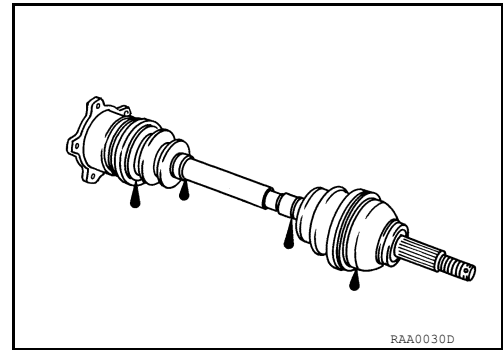

INSTALLATION

Installation is in the reverse order of removal.

- Tighten wheel nuts to specification. Refer to [WT-50, "Adjustment"](#).

A
B
C
FAX
E
F
G
H
I
J
K
L
M
N
O
P

WHEEL HUB

< UNIT REMOVAL AND INSTALLATION >

WHEEL HUB

Removal and Installation

INFOID:000000007357680

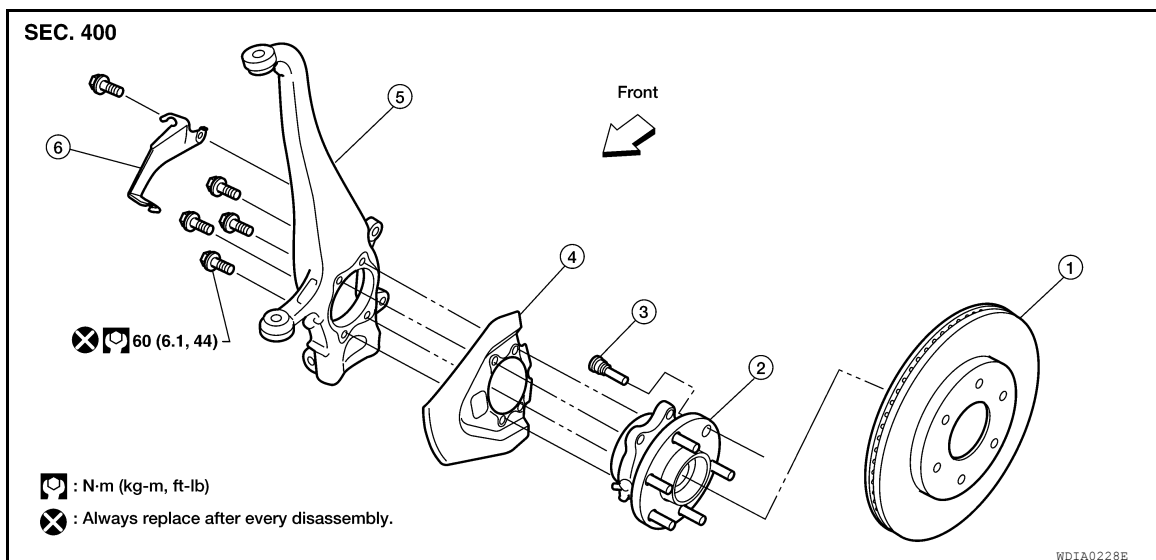

- | | | |
|-----------------|-----------------------------------|-------------------------|
| 1. Disc rotor | 2. Wheel hub and bearing assembly | 3. Wheel stud |
| 4. Splash guard | 5. Steering knuckle | 6. Wheel sensor bracket |

REMOVAL

1. Remove wheel and tire using power tool.
2. Without disassembling the hydraulic lines, remove caliper torque member bolts using power tool. Then reposition brake caliper aside with wire. Refer to [BR-42, "Removal and Installation of Brake Caliper and Disc Rotor"](#).

CAUTION:

Do not press brake pedal while brake caliper is removed.

3. Put alignment mark on disc rotor and wheel hub and bearing assembly, then remove disc rotor.

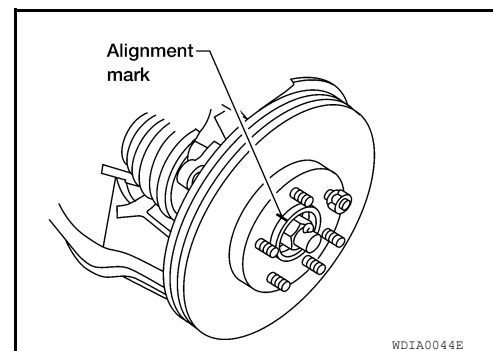

4. On 4WD models, remove cotter pin, then remove lock nut from drive shaft using power tool. Refer to [FAX-7, "VQ40DE : Removal and Installation"](#) (VQ40DE), [FAX-8, "VK56DE : Removal and Installation"](#) (VK56DE).
5. Remove wheel sensor from wheel hub and bearing assembly. Refer to [BRC-110, "Removal and Installation"](#) (TYPE 1), [BRC-229, "Removal and Installation"](#) (TYPE 2).
 - Inspect the wheel sensor O-ring, replace the wheel sensor assembly if damaged.
 - Clean the wheel sensor hole and mounting surface with a suitable brake cleaner and clean lint-free shop rag. Be careful that dirt and debris do not enter the axle bearing area.
 - Apply a coat of suitable grease to the wheel sensor O-ring and mounting hole.

CAUTION:

Do not pull on the wheel sensor harness.

6. On 4WD models, separate drive shaft from wheel hub and bearing assembly.
7. Remove wheel hub and bearing assembly bolts using power tool.

WHEEL HUB

< UNIT REMOVAL AND INSTALLATION >

8. Remove splash guard and wheel hub and bearing assembly from steering knuckle.
 - Carefully remove wheel sensor and harness through hole in splash guard.

INSPECTION AFTER REMOVAL

Check for deformity, cracks and damage on each part and replace if necessary.

INSTALLATION

Installation is in the reverse order of removal.

- Use new bolts when installing the wheel hub and bearing assembly.
- When installing disc rotor on wheel hub and bearing assembly, position the disc rotor according to alignment mark.
(When not using the alignment mark, refer to [BR-42, "Removal and Installation of Brake Caliper and Disc Rotor"](#).)
- When installing wheel and tire, refer to [WT-50, "Adjustment"](#).

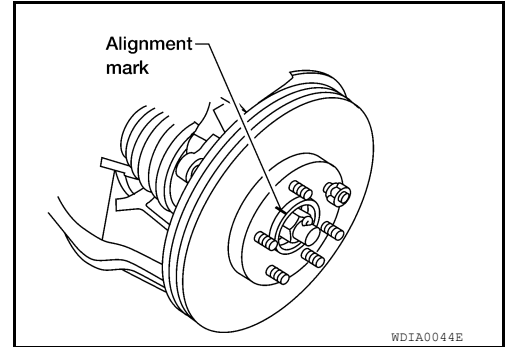

A
B
C
FAX
E
F
G
H
I
J
K
L
M
N
O
P

DRIVE SHAFT

< UNIT DISASSEMBLY AND ASSEMBLY >

UNIT DISASSEMBLY AND ASSEMBLY

DRIVE SHAFT

VQ40DE

VQ40DE : Disassembly and Assembly

INFOID:000000007357681

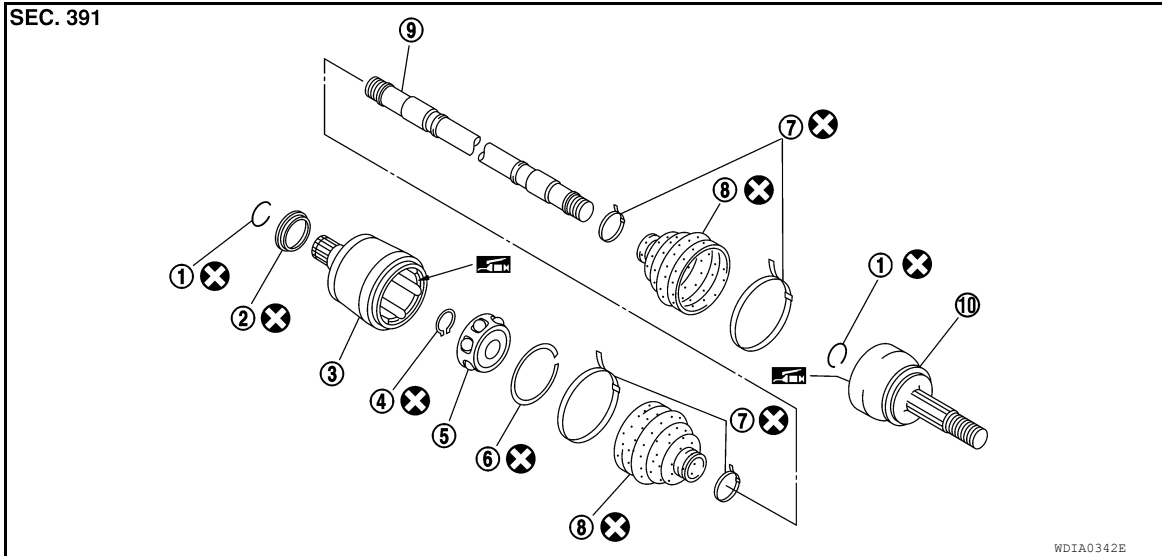

- | | | |
|------------------------|--|-----------------|
| 1. Circlip | 2. Dust cover | 3. Housing |
| 4. Snap ring | 5. Ball cage, steel ball and inner race assembly | 6. Stopper ring |
| 7. Boot band | 8. Boot | 9. Shaft |
| 10. Joint sub-assembly | | |

DISASSEMBLY

Final Drive Side

1. Mount the drive shaft in a vise.

CAUTION:

When mounting the drive shaft in a vise, use copper or aluminum plates between the vise and the drive shaft.

2. Remove boot bands and slide the boot back.
3. Put matching marks on housing and shaft before separating joint assembly.

CAUTION:

Use paint or similar substance for matching marks. Do not scratch the surfaces.

4. Remove the stopper ring with a suitable tool as shown, and pull the housing off.

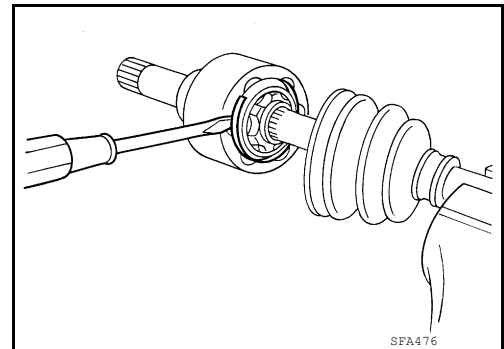

DRIVE SHAFT

< UNIT DISASSEMBLY AND ASSEMBLY >

5. Remove the snap ring, then remove the ball cage, steel ball, inner race assembly from the shaft.
6. Remove the boot from the shaft.
7. Remove circlip and dust cover from housing.
8. Clean the old grease off of the housing using paper towels.

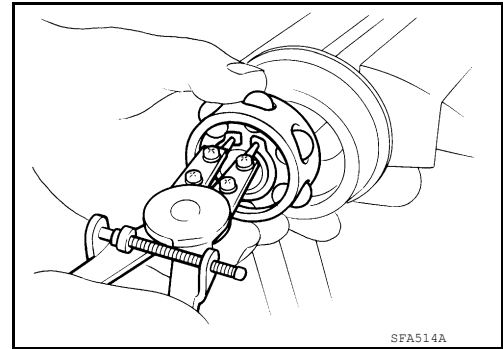

Wheel Side

1. Mount the drive shaft in a vise.

CAUTION:

When mounting the drive shaft in a vise, use copper or aluminum plates between the vise and the drive shaft.

2. Remove the boot bands and slide the boot back.
3. Screw a sliding hammer or suitable tool 30 mm (1.18 in) or more into threaded part of joint sub-assembly. Pull joint sub-assembly off of shaft as shown.

NOTE:

Align the sliding hammer and shaft and remove the joint sub-assembly by pulling directly.

CAUTION:

- If the joint sub-assembly cannot be removed after five or more unsuccessful attempts, replace the entire drive shaft assembly.

4. Remove boot from the shaft.
5. Remove circlip from the shaft.
6. While rotating the ball cage, clean the old grease off of the joint sub-assembly using paper towels.

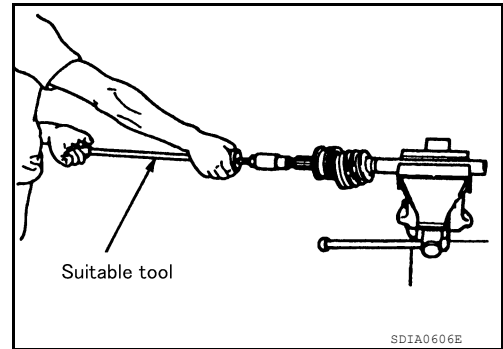

INSPECTION AFTER DISASSEMBLY

Shaft

- Replace the shaft if there is any bending, cracking, or other damage.

Joint Sub-assembly

- Check for any rough rotation or unusual axial looseness.
- Clean any foreign material from inside the joint sub-assembly.
- Check for any compression scars, cracks, or fractures.

CAUTION:

If any irregular conditions are found in the joint sub-assembly components, replace the entire joint sub-assembly.

Housing

NOTE:

Housing, ball cage, steel ball, and inner race are in a set.

- Check for any compression scars, cracks, fractures, or unusual wear on the ball rolling surface.
- Check for any deformation of the boot installation components.

Ball Cage

- Check the sliding surface for any compression scars, cracks, or fractures of sliding surface.

Steel Ball

- Check for any compression scars, cracks, fractures, or unusual wear.

Inner Race

- Check the ball sliding surface for any compression scars, cracks, or fractures.
- Check for any damage to the serrated part.

ASSEMBLY

DRIVE SHAFT

< UNIT DISASSEMBLY AND ASSEMBLY >

Final Drive Side

1. Wrap the serrated part of the shaft with tape. Install the boot band and boot to shaft.

NOTE:

Discard the old boot band and boot and use a new one for assembly.

2. Remove the tape wound around the serrated part of the shaft.

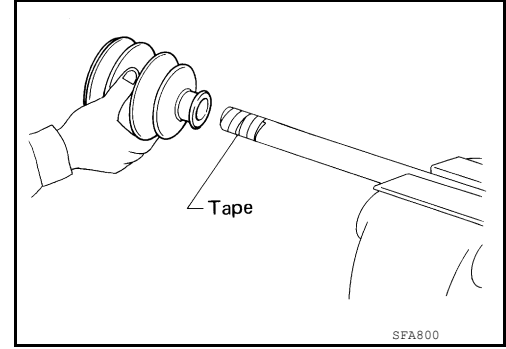

3. Install the ball cage, steel ball, and inner race assembly on the shaft, and secure them using the snap ring.

NOTE:

Discard the old snap ring and use a new one for assembly.

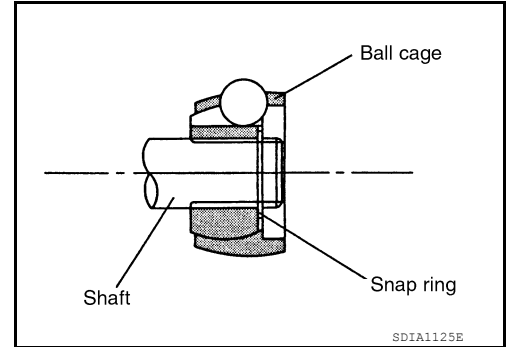

4. Insert the specified quantity of Genuine NISSAN Grease or equivalent, into the housing. Refer to [MA-18, "FOR USA AND CANADA : Fluids and Lubricants"](#) (United States and Canada), [MA-20, "FOR MEXICO : Fluids and Lubricants"](#) (Mexico).

Grease capacity : Refer to [FAX-22, "VQ40DE : Drive Shaft"](#).

CAUTION:

If grease adheres to the boot mounting surface (indicated by * marks) on shaft and housing, boot may come off. Remove all grease from surfaces.

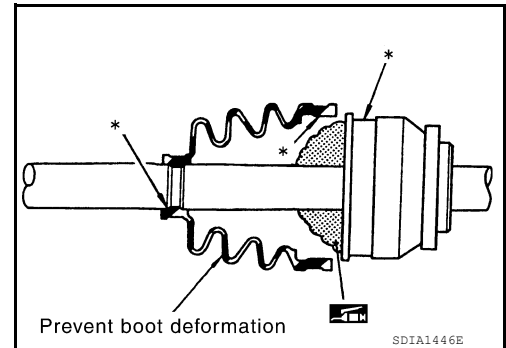

5. Install the stopper ring onto the housing.

CAUTION:

- Do not reuse stopper rings.
- Make sure that housing and stopper ring are fully engaged.

6. Install the boot securely into the grooves (indicated by * marks) as shown.

CAUTION:

If there is grease on boot mounting surfaces (indicated by * marks) of shaft and housing, boot may come off. Remove all grease from surfaces.

7. Check that the boot installation length (L) is the length indicated below. Insert a suitable tool into the large side of boot. Bleed air from boot to prevent boot deformation.

Boot installation length (L) : Refer to [FAX-22, "VQ40DE : Drive Shaft"](#).

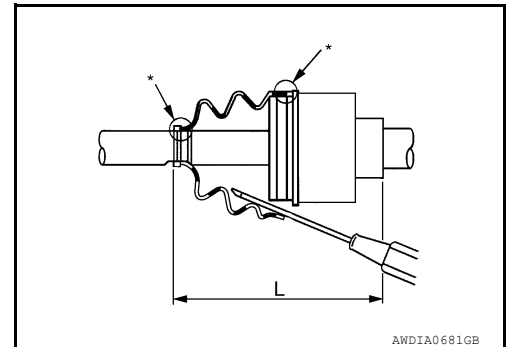

CAUTION:

- The boot may break if the boot installation length is less than the specified value.
- Do not touch the tip of the suitable tool to the inside of the boot.

DRIVE SHAFT

< UNIT DISASSEMBLY AND ASSEMBLY >

- Secure the big and small ends of the boot with the new boot bands as shown.

NOTE:

Discard not reuse boot bands.

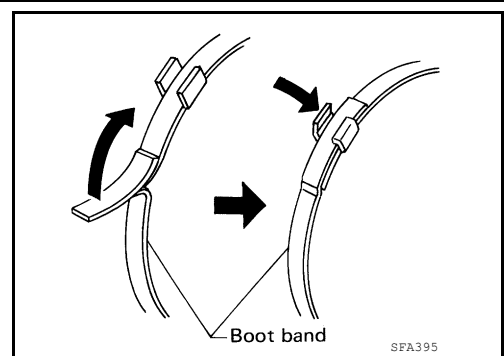

- Secure housing and shaft and then make sure that they are in the correct position when rotating boot. Use a new boot band if the boot band needs to be loosened to reposition the boot.

- Install circlip and dust cover to housing.

NOTE:

Do not reuse circlip and dust cover.

Wheel Side

- Insert the Genuine NISSAN Grease or equivalent, into the joint sub-assembly serration hole until the grease begins to ooze from the ball groove and serration hole. Refer to [MA-18, "FOR USA AND CANADA : Fluids and Lubricants"](#) (United States and Canada), [MA-20, "FOR MEXICO : Fluids and Lubricants"](#) (Mexico). After inserting the grease, use a shop cloth to wipe off the grease that has oozed out.

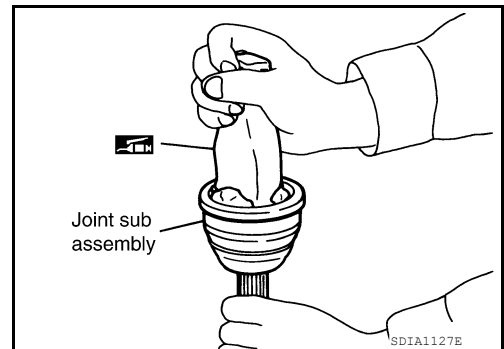

- Wrap the serrated part of the shaft with tape. Install the boot band and boot onto the shaft. Do not damage the boot.

NOTE:

Discard the old boot band and boot and use a new one for assembly.

- Remove the protective tape wound around the serrated part of the shaft.

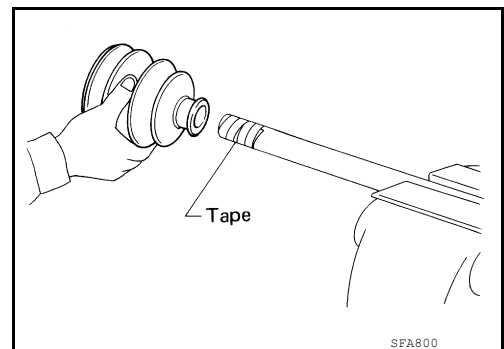

- Attach the circlip to the shaft. The circlip must fit securely into the shaft groove. Attach the nut to the joint sub-assembly. Use a soft hammer to press-fit the circlip.

NOTE:

Discard the old circlip and use a new one for assembly.

- Insert the specified quantity of Genuine NISSAN Grease or equivalent, into the joint sub-assembly and the large end of the boot. Refer to [MA-18, "FOR USA AND CANADA : Fluids and Lubricants"](#) (United States and Canada), [MA-20, "FOR MEXICO : Fluids and Lubricants"](#) (Mexico).

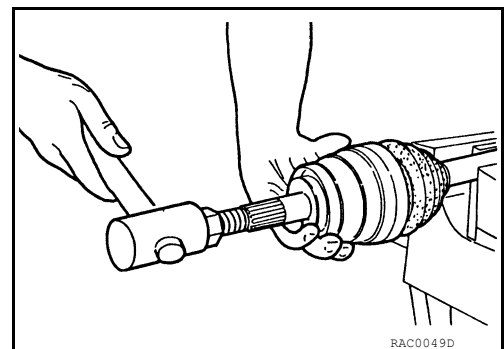

Grease capacity : Refer to [FAX-22, "VQ40DE : Drive Shaft"](#).

DRIVE SHAFT

< UNIT DISASSEMBLY AND ASSEMBLY >

6. Install the boot securely into the grooves (indicated by the * marks) as shown.

CAUTION:

If there is grease on the boot mounting surfaces (indicated by the * marks) of the shaft and joint sub-assembly, the boot may come off. Remove all grease from the drive shaft surfaces.

7. Check that the boot installation length (L) is the specified length. Insert a suitable tool into the large side of the boot. Bleed the air from the boot to prevent boot deformation.

Boot installation length (L) : Refer to [FAX-22, "VQ40DE : Drive Shaft"](#).

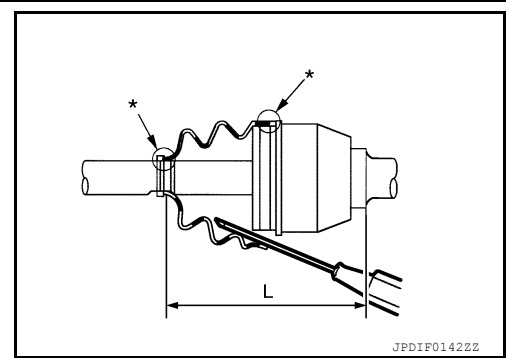

CAUTION:

- The boot may break if the boot installation length is less than the specified length.
- Do not contact inside surface of boot with the tip of the suitable tool.

8. Secure large and small ends of the boot using new boot bands using a boot band crimping tool as shown.

Tool number : KV40107300 (—)

NOTE:

Do not reuse boot bands.

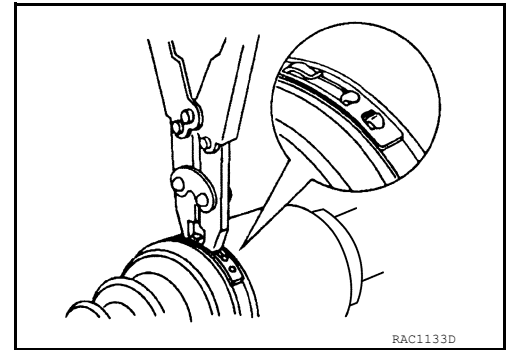

- Secure boot band so that dimension (M) meets specification as shown.

Dimension (M) : Refer to [FAX-22, "VQ40DE : Boot Bands"](#).

9. After installing the housing to the shaft, rotate the boot to check that it is positioned correctly. If the boot is not positioned correctly, remove the old boot bands then reposition the boot and secure the boot with new boot bands.

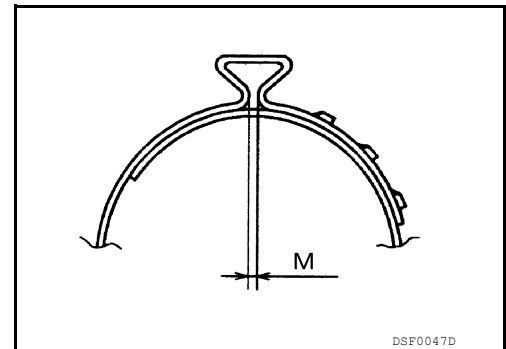

VK56DE

DRIVE SHAFT

< UNIT DISASSEMBLY AND ASSEMBLY >

VK56DE : Disassembly and Assembly

INFOID:000000007357682

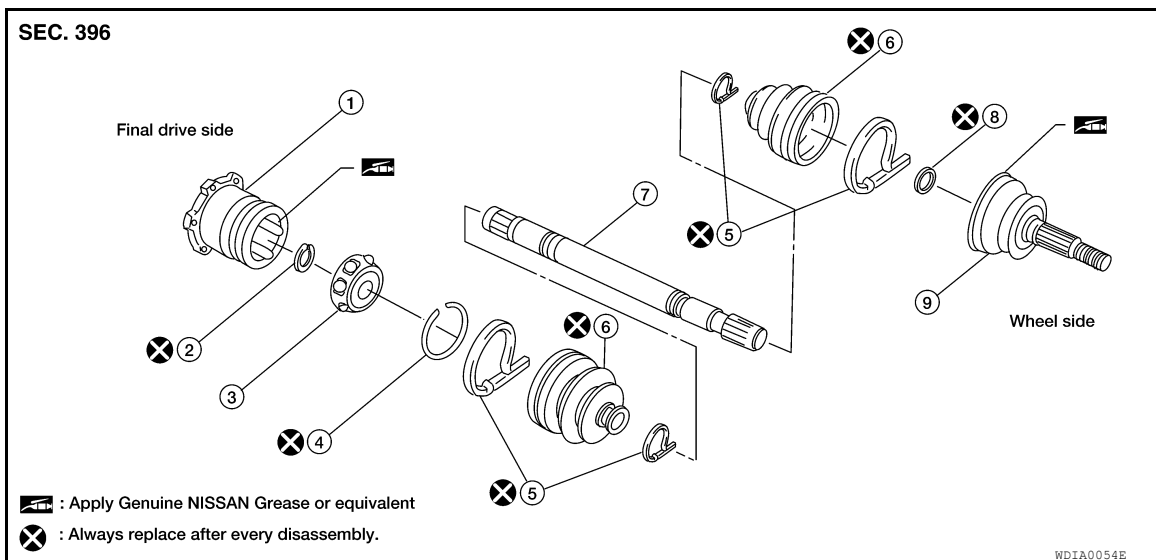

- | | | |
|--------------------------|--------------|---|
| 1. Sliding joint housing | 2. Snap ring | 3. Ball cage, steel ball, inner race assembly |
| 4. Stopper ring | 5. Boot band | 6. Boot |
| 7. Drive shaft | 8. Circlip | 9. Joint sub-assembly |

DISASSEMBLY

Final Drive Side

1. Mount the drive shaft in a vise.

CAUTION:

When mounting the drive shaft in a vise, use copper or aluminum plates between the vise and the drive shaft.

2. Remove the boot bands.
3. Remove the stopper ring with a suitable tool as shown, and pull the housing off.

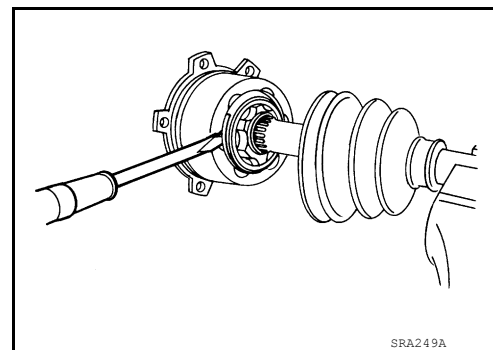

4. Remove the snap ring, then remove the ball cage, steel ball, inner race assembly from the drive shaft.

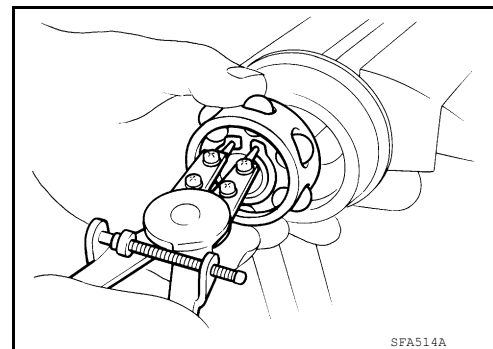

5. Remove the boot from the drive shaft.

A
B
C
FAX
E
F
G
H
I
J
K
L
M
N
O
P

DRIVE SHAFT

< UNIT DISASSEMBLY AND ASSEMBLY >

6. Remove any old grease on the housing using paper towels.

Wheel Side

1. Mount the drive shaft in a vise.

CAUTION:

When mounting the drive shaft in a vise, use copper or aluminum plates between the vise and the drive shaft.

2. Remove the boot bands, then remove the boot from the joint sub-assembly.
3. Screw a suitable drive shaft puller 30 mm (1.18 in) or more into the threaded part of the joint sub-assembly. Pull the joint sub-assembly off of the drive shaft as shown.

NOTE:

Align the sliding hammer and drive shaft and remove the joint sub-assembly by pulling directly.

CAUTION:

- **If the joint sub-assembly cannot be removed after five or more attempts, replace the drive shaft and joint sub-assembly as a set.**

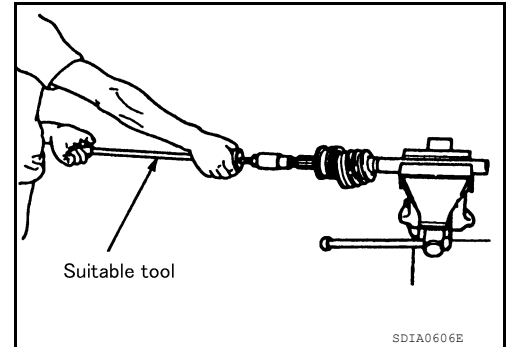

4. Remove the boot from the drive shaft.
5. Remove the circlip from the drive shaft.
6. While rotating the ball cage, remove any old grease from the joint sub-assembly using paper towels.

INSPECTION AFTER DISASSEMBLY

Drive Shaft

- Replace the drive shaft if there is any runout, cracking, or other damage.

Joint Sub-assembly

- Check for any rough rotation or unusual axial looseness.
- Clean any foreign material from inside the joint sub-assembly.
- Check for any compression scars, cracks, or fractures.

CAUTION:

If any defective conditions are found in the joint sub-assembly components, replace the entire joint sub-assembly.

Sliding Joint Side Housing

- Check for any compression scars, cracks, fractures, or unusual wear on the ball rolling surface.
- Check for any damage to the drive shaft screws.
- Check for any deformation of the boot installation components.

Ball Cage

- Check the sliding surface for any compression scars, cracks, or fractures.

Steel Ball

- Check for any compression scars, cracks, fractures, or unusual wear.

Inner Race

- Check the ball sliding surface for any compression scars, cracks, or fractures.
- Check for any damage to the serrated part.

CAUTION:

If any defective conditions are found, install a new housing, ball cage, steel ball, and inner race as a set.

ASSEMBLY

Final Drive Side

DRIVE SHAFT

< UNIT DISASSEMBLY AND ASSEMBLY >

1. Wrap the serrated part of the drive shaft with tape. Install the boot band and boot to drive shaft.

NOTE:

Discard the old boot band and boot and use a new one for assembly.

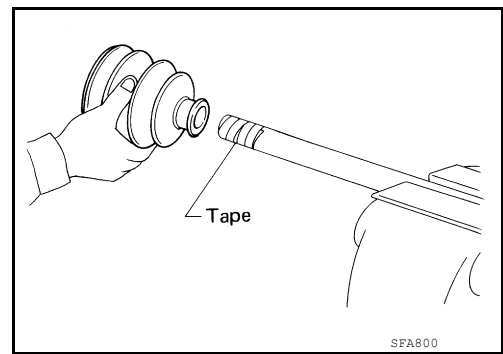

2. Remove the tape wound around the serrated part of the drive shaft.

3. Install the ball cage, steel ball, and inner race assembly on the drive shaft, and secure them tightly using the snap ring.

NOTE:

Discard the old snap ring and use a new one for assembly.

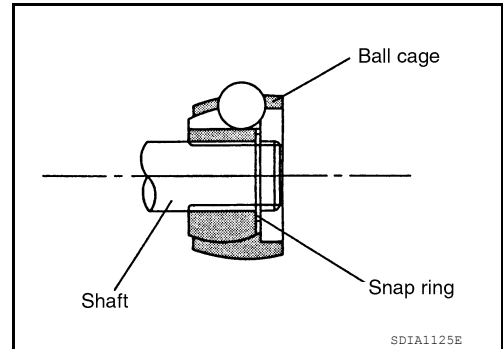

4. Insert the specified quantity of Genuine NISSAN Grease or equivalent, onto the housing (indicated by * marks), and install it onto shaft. Refer to [MA-18, "FOR USA AND CANADA : Fluids and Lubricants"](#).

Grease capacity : Refer to [FAX-23, "VK56DE : Drive Shaft"](#).

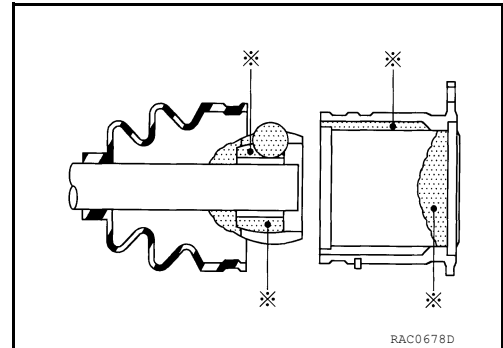

5. Install the stopper ring onto the housing.
6. After installation, pull on the shaft to check engagement between the sliding joint and the stopper ring.

7. Install the boot securely into the grooves (indicated by * marks) as shown.

CAUTION:

If there is grease on boot mounting surfaces (indicated by * marks) of shaft and housing, boot may come off. Remove all grease from surfaces.

8. Check that the boot installation length (L) is the length indicated below. Insert a suitable tool into the large end of the boot. Bleed air from the boot to prevent boot deformation.

Boot installation length (L) : Refer to [FAX-23, "VK56DE : Drive Shaft"](#).

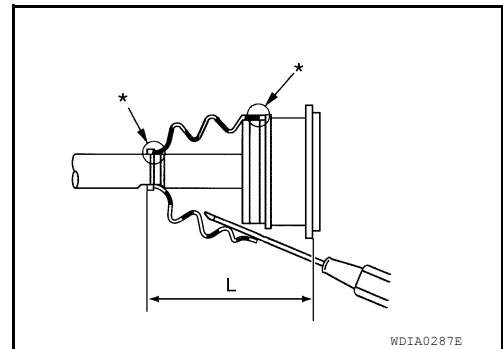

CAUTION:

- The boot may break if the boot installation length is less than the specified value.
- Do not to touch the tip of the suitable tool to the inside of the boot.

DRIVE SHAFT

< UNIT DISASSEMBLY AND ASSEMBLY >

- Secure the large and small ends of the boot with the new boot bands as shown.

NOTE:

Discard the old boot bands and use new ones for assembly.

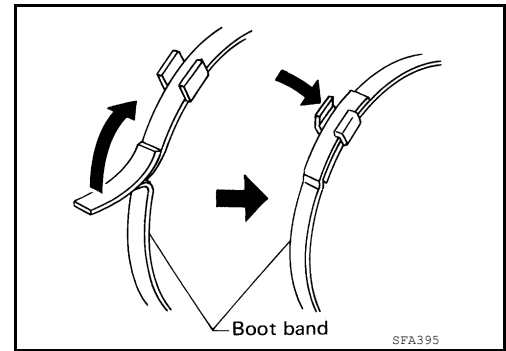

- After installing the sliding joint housing to the drive shaft, rotate the boot to check that the boot is positioned correctly. If the boot is not positioned correctly, reposition the boot and secure the boot using a new boot band.

Wheel Side

- Insert the Genuine NISSAN Grease or equivalent, into the joint sub-assembly serration hole until the grease begins to ooze from the ball groove and serration hole. Refer to [MA-18, "FOR USA AND CANADA : Fluids and Lubricants"](#). After inserting the grease, use a shop cloth to wipe off the grease that has oozed out.

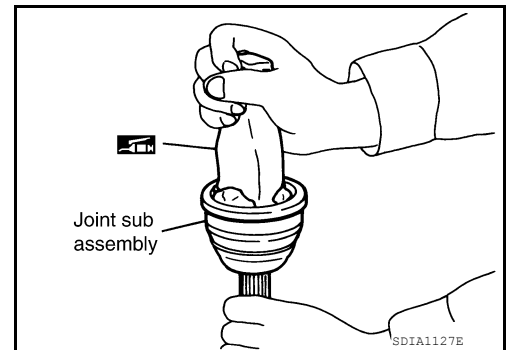

- Wrap the serrated part of the drive shaft with tape. Install the boot band and boot onto the shaft. Do not damage the boot.

NOTE:

Discard the old boot band and boot and use a new one for assembly.

- Remove the protective tape wound around the serrated part of the drive shaft.

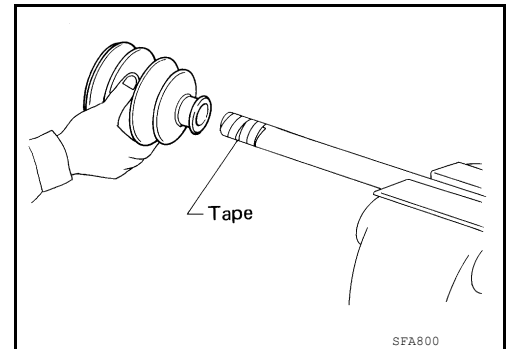

- Attach the circlip to the drive shaft. The circlip must fit securely into the drive shaft groove. Attach the nut to the joint sub-assembly.

Use a soft hammer to press-fit the circlip.

NOTE:

Discard the old circlip and use a new one for assembly.

- Insert the specified quantity of Genuine NISSAN Grease or equivalent, into the joint sub-assembly and the large end of the boot. Refer to [MA-18, "FOR USA AND CANADA : Fluids and Lubricants"](#).

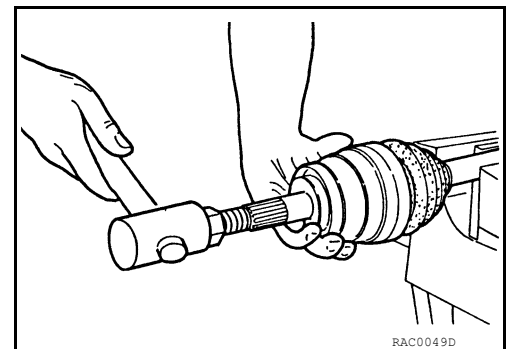

Grease capacity : Refer to [FAX-23, "VK56DE : Drive Shaft"](#).

DRIVE SHAFT

< UNIT DISASSEMBLY AND ASSEMBLY >

6. Install the boot securely into the grooves (indicated by the * marks) as shown.

CAUTION:

If there is grease on the boot mounting surfaces (indicated by the * marks) of the drive shaft and joint sub-assembly, the boot may come off. Remove all grease from the drive shaft surfaces.

7. Check that the boot installation length (L) is the specified length. Insert a suitable tool into the large end of the boot. Bleed the air from the boot to prevent boot deformation.

Boot installation length (L) : Refer to [FAX-23, "VK56DE : Drive Shaft"](#).

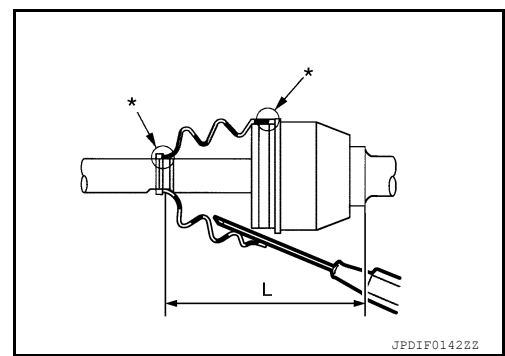

A

B

C

FAX

CAUTION:

- The boot may break if the boot installation length is less than the specified length.
- Do not contact inside surface of boot with the tip of the suitable tool.

8. Secure large and small ends of the boot using new boot bands using tool as shown.

Tool number : KV40107300 (—)

NOTE:

Discard the old boot bands and use new ones for assembly.

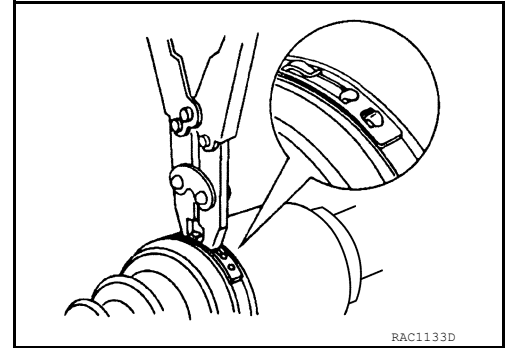

E

F

G

H

I

- Secure boot band so that dimension (M) meets specification as shown.

Dimension (M) : Refer to [FAX-23, "VK56DE : Boot Bands"](#).

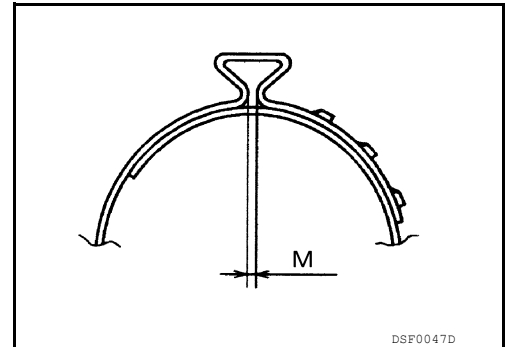

J

K

L

9. After installing the housing to the shaft, rotate the boot to check that it is positioned correctly. If the boot is not positioned correctly, remove the old boot bands then reposition the boot and secure the boot with new boot bands.

M

N

O

P

SERVICE DATA AND SPECIFICATIONS (SDS)

< SERVICE DATA AND SPECIFICATIONS (SDS)

SERVICE DATA AND SPECIFICATIONS (SDS)

SERVICE DATA AND SPECIFICATIONS (SDS)

VQ40DE

VQ40DE : Wheel Bearing

INFOID:000000007357683

Axial end play limit	0.05 mm (0.002 in) or less
----------------------	----------------------------

VQ40DE : Drive Shaft

INFOID:000000007357684

Wheel side

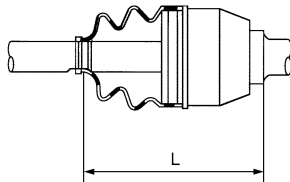

Final drive side

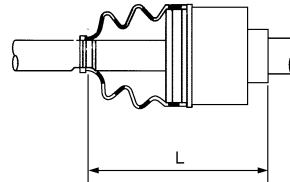

AWDIA0682GB

Drive shaft joint type	Final drive side	Rzeppa	
	Wheel side	Rzeppa	
Grease	Quality	Genuine NISSAN Grease or equivalent	
	Capacity	Final drive side	120 - 140 g (4.23 - 4.94 oz)
		Wheel side	110 - 130 g (3.88 - 4.59 oz)
Boot installed length (L)	Final drive side	163.9 - 164.3 mm (6.45 - 6.47 in)	
	Wheel side	135.1 mm (5.32 in)	

VQ40DE : Boot Bands

INFOID:000000007357685

Unit: mm (in)

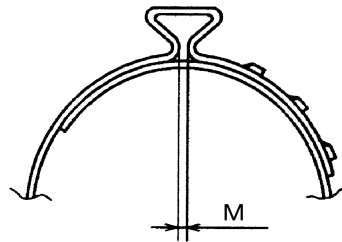

DSF0047D

Dimension (M)	1.0 - 4.0 (0.039 - 0.157)
---------------	---------------------------

VK56DE

VK56DE : Wheel Bearing

INFOID:000000007357686

Wheel bearing axial end play	0.05 mm (0.002 in) or less
------------------------------	----------------------------

SERVICE DATA AND SPECIFICATIONS (SDS)

< SERVICE DATA AND SPECIFICATIONS (SDS)

VK56DE : Drive Shaft

INFOID:000000007357687

Final drive side

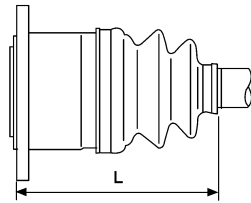

Wheel side

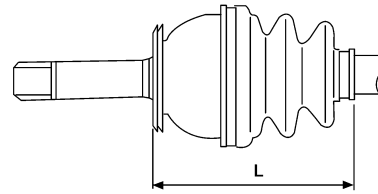

WDIA0055E

Drive shaft joint type	Final drive side	Rzeppa	
	Wheel side	Rzeppa	
Grease	Quality	Nissan Genuine Grease or equivalent	
	Capacity	Final drive side	110 - 130 g (3.88 - 4.59 oz)
		Wheel side	130 - 150 g (4.59 - 5.29 oz)
Boot length	Final drive side (L)	145 mm (5.71 in)	
	Wheel side (L)	135.1 mm (5.32 in)	

VK56DE : Boot Bands

INFOID:000000007357688

Unit: mm (in)

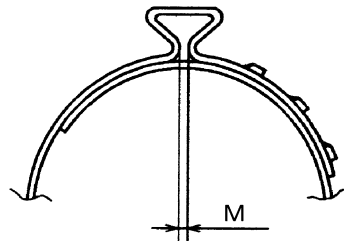

DSF0047D

Dimension (M)	1.0 - 4.0 (0.039 - 0.157)
---------------	---------------------------

A
B
C
FAX
E
F
G
H
I
J
K
L
M
N
O
P