

SECTION **BRM**
 BODY REPAIR

A
 B
 C
 D
 E
 F
 G
 H
 I
 J
 BRM
 L
 M
 N
 O
 P

CONTENTS

VEHICLE INFORMATION	2	BODY SEALING	21
BODY EXTERIOR PAINT COLOR	2	Description	21
Body Exterior Paint Color	2	BODY CONSTRUCTION	24
PRECAUTION	3	Body Construction	24
PRECAUTIONS	3	REPLACEMENT OPERATIONS	26
Precaution for Supplemental Restraint System (SRS) "AIR BAG" and "SEAT BELT PRE-TEN- SIONER"	3	Description	26
HANDLING PRECAUTIONS FOR PLASTICS	4	Hoodledge	29
Precautions For Plastics	4	Front Side Member (Partial Replacement)	30
REPAIRING HIGH STRENGTH STEEL	8	Front Pillar	31
High Strength Steel (HSS)	8	Dash Side	34
Handling of Ultra High Strength Steel Plate Parts...	10	Center Pillar	35
PREPARATION	11	Outer Sill Reinforcement	36
REPAIRING MATERIAL	11	Rear Fender	38
Foam Repair	11	Rear Body Side Inner Assembly	39
BODY COMPONENT PARTS	12	Rear Floor Rear	40
Underbody Component Parts	12	Rear Panel Assembly	42
Body Component Parts	16	Roof	43
REMOVAL AND INSTALLATION	18	Rear Side Member Extension	44
CORROSION PROTECTION	18	SERVICE DATA AND SPECIFICATIONS (SDS)	45
Description	18	BODY ALIGNMENT	45
Anti-Corrosive Wax	18	Body Center Marks	45
Undercoating	19	Description	46
		Engine Compartment	46
		Underbody	47
		Passenger Compartment	50
		Rear Body	51

BODY EXTERIOR PAINT COLOR

< VEHICLE INFORMATION >

VEHICLE INFORMATION

BODY EXTERIOR PAINT COLOR

Body Exterior Paint Color

INFOID:000000008506506

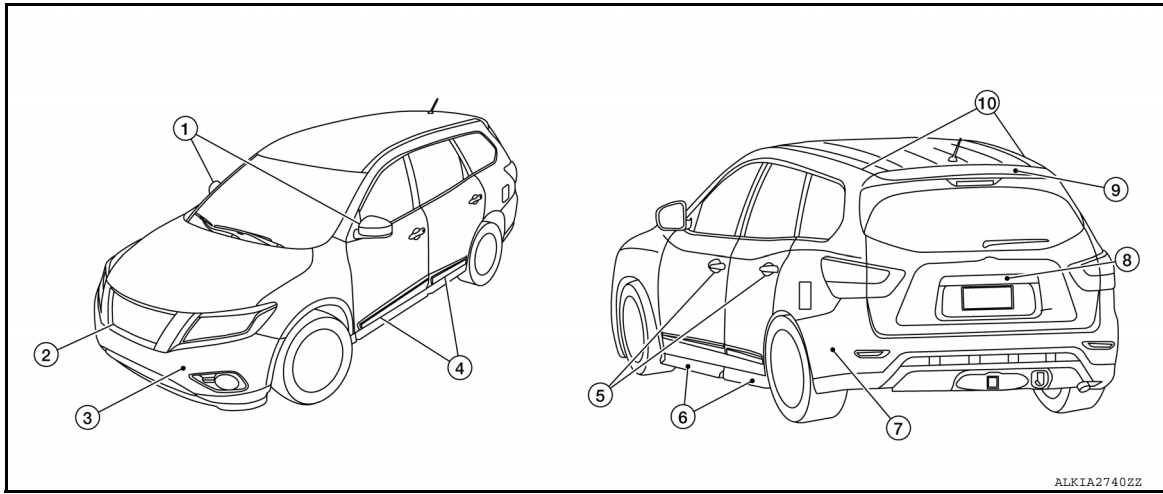

Component	Color code	CAL	HAE	K23	K50	KH3	NAH	RBG	QAA	
	Description	Brown	Gold	Silver	Gray	Black	Red	Blue	White	
	Paint type	M	M	M	M	S	M	M	P	
	Hard clear coat	t	t	t	t	t	t	t	t	
1	Door mirror	Body color	CAL	HAE	K23	K50	KH3	NAH	RBG	QAA
2	Front grille	Chromium Plate	Cr2P	Cr2P	Cr2P	Cr2P	Cr2P	Cr2P	Cr2P	Cr2P
3	Front bumper fascia	Body color	CAL	HAE	K23	K50	KH3	NAH	RBG	QAA
4	Side guard molding	Chromium Plate	Cr2P	Cr2P	Cr2P	Cr2P	Cr2P	Cr2P	Cr2P	Cr2P
5	Door outside handle	Chromium Plate	Cr2P	Cr2P	Cr2P	Cr2P	Cr2P	Cr2P	Cr2P	Cr2P
6	Sill molding	Black	KH3	KH3	KH3	KH3	KH3	KH3	KH3	KH3
7	Rear bumper fascia	Body color	CAL	HAE	K23	K50	KH3	NAH	RBG	QAA
8	Back door outer finisher	Chromium Plate	Cr2P	Cr2P	Cr2P	Cr2P	Cr2P	Cr2P	Cr2P	Cr2P
9	Rear spoiler	Body color	CAL	HAE	K23	K50	KH3	NAH	RBG	QAA
10	Roof side molding	Black	KH3	KH3	KH3	KH3	KH3	KH3	KH3	KH3

M = Metallic, S = Solid, 2S = Solid and Clear, 2 P = 2-coat Pearl, 3P = 3-coat pearl, P = Pearl, Black is solvent based, all others are water based, t = TMAC clear coat

PRECAUTIONS

< PRECAUTION >

PRECAUTION

PRECAUTIONS

Precaution for Supplemental Restraint System (SRS) "AIR BAG" and "SEAT BELT PRE-TENSIONER"

INFOID:000000008885921

The Supplemental Restraint System such as "AIR BAG" and "SEAT BELT PRE-TENSIONER", used along with a front seat belt, helps to reduce the risk or severity of injury to the driver and front passenger for certain types of collision. Information necessary to service the system safely is included in the SR and SB section of this Service Manual.

WARNING:

- To avoid rendering the SRS inoperative, which could increase the risk of personal injury or death in the event of a collision which would result in air bag inflation, all maintenance must be performed by an authorized NISSAN/INFINITI dealer.
- Improper maintenance, including incorrect removal and installation of the SRS, can lead to personal injury caused by unintentional activation of the system. For removal of Spiral Cable and Air Bag Module, see the SR section.
- Do not use electrical test equipment on any circuit related to the SRS unless instructed to in this Service Manual. SRS wiring harnesses can be identified by yellow and/or orange harnesses or harness connectors.

PRECAUTIONS WHEN USING POWER TOOLS (AIR OR ELECTRIC) AND HAMMERS

WARNING:

- When working near the Airbag Diagnosis Sensor Unit or other Airbag System sensors with the Ignition ON or engine running, DO NOT use air or electric power tools or strike near the sensor(s) with a hammer. Heavy vibration could activate the sensor(s) and deploy the air bag(s), possibly causing serious injury.
- When using air or electric power tools or hammers, always switch the Ignition OFF, disconnect the battery and wait at least 3 minutes before performing any service.

A
B
C
D
E
F
G
H
I
J
L
M
N
O
P

BRM

HANDLING PRECAUTIONS FOR PLASTICS

< PRECAUTION >

HANDLING PRECAUTIONS FOR PLASTICS

Precautions For Plastics

INFOID:000000008506537

Abbreviation	Material name	Heatresisting temperature °C (°F)	Resistance to gasoline and solvents	Other cautions
PE	Polyethylene	60(140)	Gasoline and most solvents are harmless if applied for a very short time (wipe up quickly).	Flammable
PVC	Poly Vinyl Chloride	80(176)	Same as above.	Poison gas is emitted when burned.
EPM/EPDM	Ethylene Propylene (Diene) copolymer	80(176)	Same as above.	Flammable
TPO/TPR	Thermoplastic Olefine/ Thermoplastic rubber	80(176)	Same as above.	Flammable
PP	Polypropylene	90(194)	Same as above.	Flammable, avoid battery acid.
UP	Unsaturated Polyester	90(194)	Same as above.	Flammable
PS	Polystyrene	80(176)	Avoid solvents.	Flammable
ABS	Acrylonitrile Butadiene Styrene	80(176)	Avoid gasoline and solvents.	—
PMMA	Poly Methyl Methacrylate	85(185)	Same as above.	—
EVAC	Ethylene Vinyl Acetate	90(194)	Same as above.	—
ASA	Acrylonitrile Styrene Acrylate	100(222)	Same as above.	Flammable
PPE	Poly Phenylene Ether	110(230)	Same as above.	—
PC	Polycarbonate	120(248)	Same as above.	—
PAR	Polyarylate	180(356)	Same as above.	—
PUR	Polyurethane	90(194)	Same as above.	—
PPC	Polypropylene Composite	115 (239)	Same as above	Flammable
POM	Poly Oxymethylene	120(248)	Same as above.	Avoid battery acid.
PBT+PC	Poly Butylene Terephthalate + Polycarbonate	120(248)	Same as above.	Flammable
PA	Polyamide (Nylon)	140(284)	Same as above.	Avoid immersing in water.
PBT	Poly Butylene Terephthalate	140(284)	Same as above.	—
PET	Polyester	180(356)	Same as above.	—
PEI	Polyetherimide	200(392)	Same as above.	—

1. When repairing and painting a portion of the body adjacent to plastic parts, consider their characteristics (influence of heat and solvent) and remove them if necessary or take suitable measures to protect them.
2. Plastic parts should be repaired and painted using methods suiting the materials' characteristics.

HANDLING PRECAUTIONS FOR PLASTICS

< PRECAUTION >

LOCATION OF PLASTIC PARTS

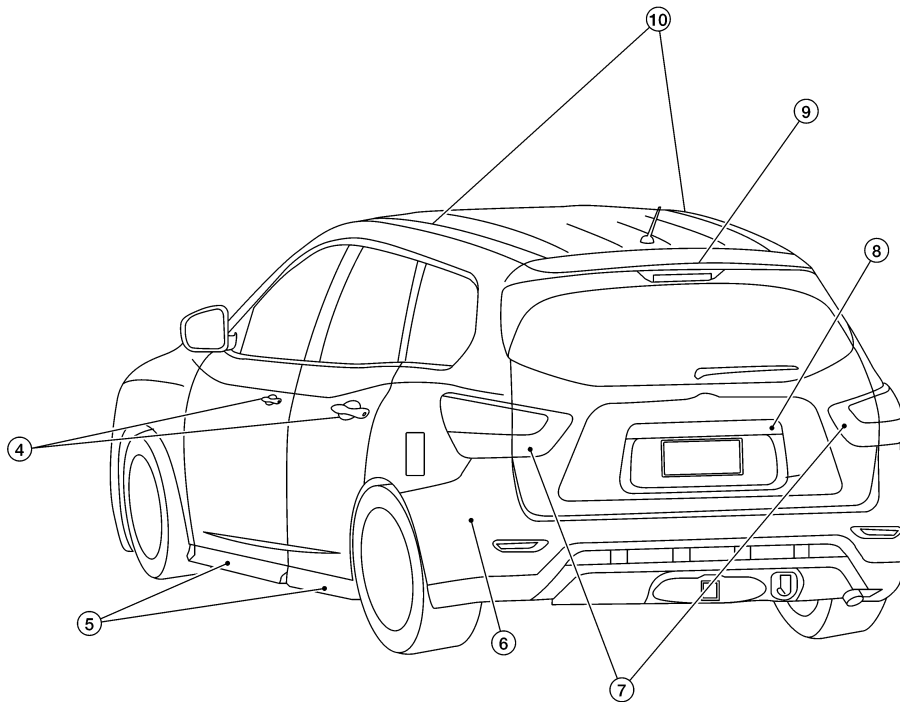
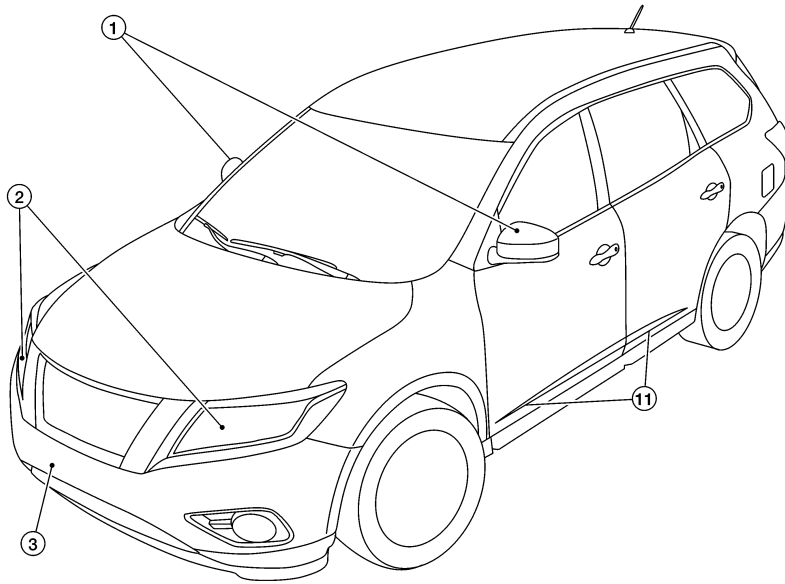

A
B
C
D
E
F
G
H
I
J
L
M
N
O
P

BRM

ALKIA2823ZZ

Item	Component	Abbreviation	Material
1.	Door mirror	Base	PA Polyamide (Nylon)
		Housing	ABS Acrylonitrile Butadiene Styrene
2.	Front combination lamp	Lens	PC Polycarbonate
		Housing	PP Polypropylene
3.	Front bumper fascia	PP	Polypropylene

HANDLING PRECAUTIONS FOR PLASTICS

< PRECAUTION >

Item	Component	Abbreviation	Material
4.	Outside door handle	Grip	PC Polycarbonate
		Escutcheon	PA Polyamide (Nylon)
5.	Sill molding	TPO	Thermoplastic Olefine
6.	Rear bumper fascia	PP	Polypropylene
7.	Rear combination lamp	Lens	PMMA Poly Methyl Methacrylate
		Housing	ASA Acrylonitrile Styrene Acrylate
8.	Back door outer finisher (upper/lower)	ABS + PC	Acrylonitrile Butadiene Styrene + Polycarbonate
9.	Rear spoiler	ABS + PC	Acrylonitrile Butadiene Styrene + Polycarbonate
10.	Roof side molding	ABS + PC	Acrylonitrile Butadiene Styrene + Polycarbonate
11.	Body side molding	PC	Polycarbonate

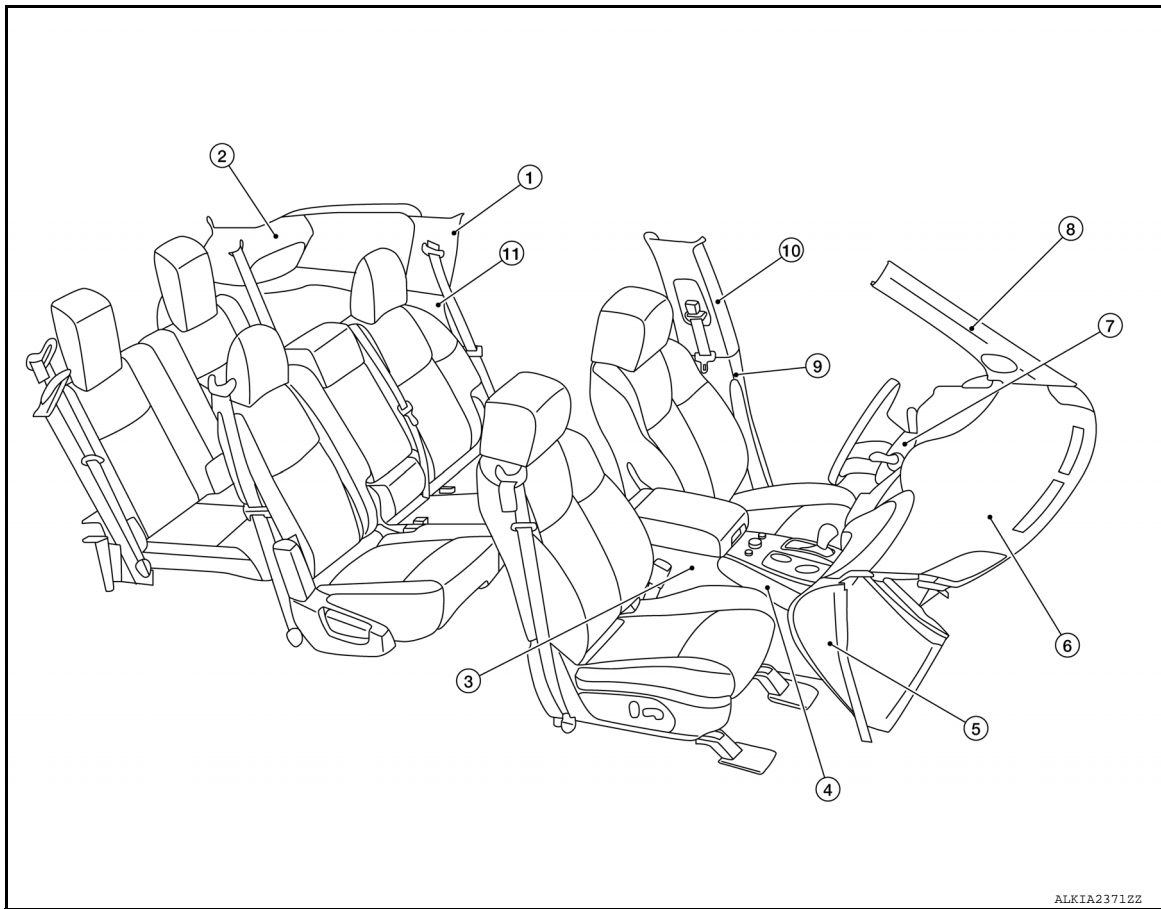

Item	Component	Abbreviation	Material
1.	Rear pillar finisher	PP	Polypropylene
2.	Back pillar finisher	PP	Polypropylene
3.	Center console assembly	Base	PP + EPDM Polypropylene + Ethylene Propylene (Diene) copolymer
		Box	ABS + PC Acrylonitrile Butadiene Styrene + Polycarbonate
4.	CVT shift selector finisher	ABS + PC	Acrylonitrile Butadiene Styrene + Polycarbonate
5.	Instrument panel side finisher	PP + EPDM	Polypropylene + Ethylene Propylene (Diene) copolymer
6.	Instrument panel	Base	PPC Polypropylene Composite
		Skin	PET Polyester

HANDLING PRECAUTIONS FOR PLASTICS

< PRECAUTION >

Item	Component		Abbreviation	Material
7.	Steering column covers		PP	Polypropylene
8.	Front pillar finisher	Core	PP	Polypropylene
		Skin	PET	Polyester
9.	Center pillar lower finisher		PP	Polypropylene
10.	Center pillar upper finisher	Core	PP	Polypropylene
11.	Luggage side finisher		PP	Polypropylene

A
B
C
D
E
F
G
H
I
J
L
M
N
O
P

BRM

REPAIRING HIGH STRENGTH STEEL

< PRECAUTION >

REPAIRING HIGH STRENGTH STEEL

High Strength Steel (HSS)

INFOID:000000008506508

High strength steel is used for body panels in order to reduce vehicle weight.

Accordingly, precautions in repairing automotive bodies made of high strength steel are described below:

Tensile strength	Major applicable parts
370 - 590 MPa	<ul style="list-style-type: none"> • Lower front and rear hoodledge • Upper hoodledge • Side dash • Roof bow No. 2 and No.4 • 3rd, crossmember (Front floor component part) • Inner sill • Rear side member assembly • Lower dash • 2nd, 4th, 5th, and 7th crossmember • Front side member outrigger • 2nd crossmember extension • Seatbelt anchor reinforcement • Center pillar reinforcement • Front seat inner and outer mounting bracket • Side member outrigger • Rear floor front extension • Other reinforcements
780 - 1350 MPa	<ul style="list-style-type: none"> • Front side member assembly • Front side member closing plate assembly • Front side member extension • Front side member extension front • Outer roof rail reinforcement (Side body assembly component part) • Front suspension inner and outer mounting bracket • Inner sill • Front pillar upper reinforcement • Center pillar outer reinforcement • Front side member stiffener

Read the following precautions when repairing HSS:

1. Additional points to consider:

- The repair of reinforcements (such as side members) by heating is not recommended since it may weaken the component. When heating is unavoidable, do not heat HSS parts above 550°C (1,022°F).

Verify heating temperature with a thermometer.

(Crayon-type and other similar type thermometers are appropriate.)

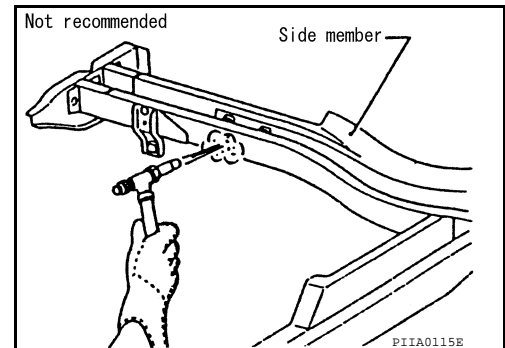

REPAIRING HIGH STRENGTH STEEL

< PRECAUTION >

- When straightening body panels, use caution in pulling any HSS panel. Because HSS is very strong, pulling may cause deformation in adjacent portions of the body. In this case, increase the number of measuring points and carefully pull the HSS panel.

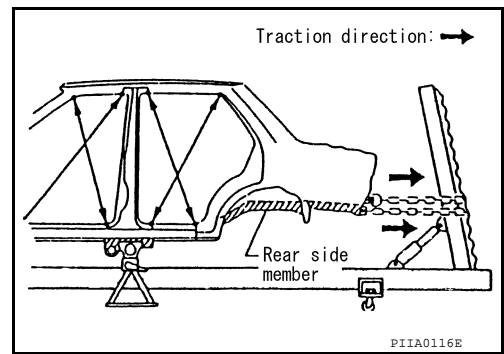

- When cutting HSS panels, avoid gas (torch) cutting if possible. Instead, use a saw to avoid weakening surrounding areas due to heat. If gas (torch) cutting is unavoidable, allow a minimum margin of 50 mm (1.97 in).

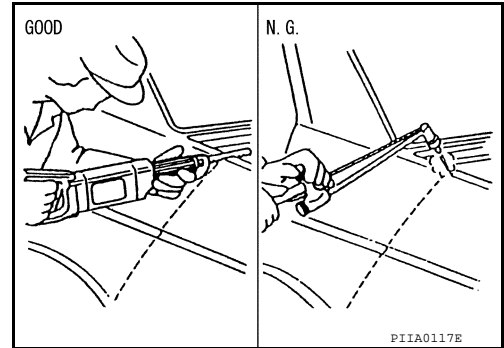

- When welding HSS panels, use spot welding whenever possible in order to minimize weakening surrounding areas due to heat. If spot welding is impossible, use MIG. welding. Do not use gas (torch) for welding because it is inferior in welding strength.

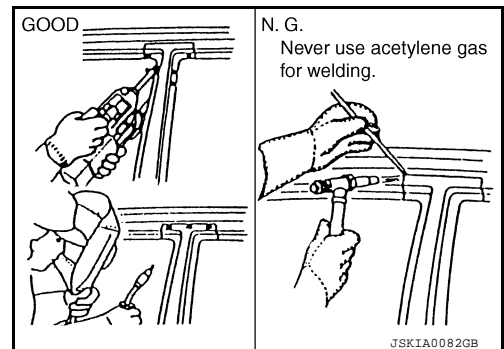

- The spot weld on HSS panels is harder than that of an ordinary steel panel. Therefore, when cutting spot welds on a HSS panel, use a low speed high torque drill (1,000 to 1,200 rpm) to increase drill bit durability and facilitate the operation.

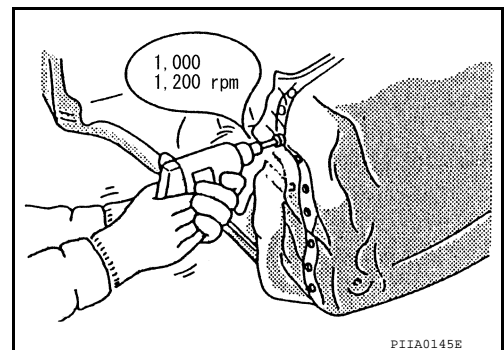

A
B
C
D
E
F
G
H
I
J
BRM
L
M
N
O
P

REPAIRING HIGH STRENGTH STEEL

< PRECAUTION >

2. Precautions in spot welding HSS

This work should be performed under standard working conditions. Always note the following when spot welding HSS:

- The electrode tip diameter must be sized properly according to the metal thickness.

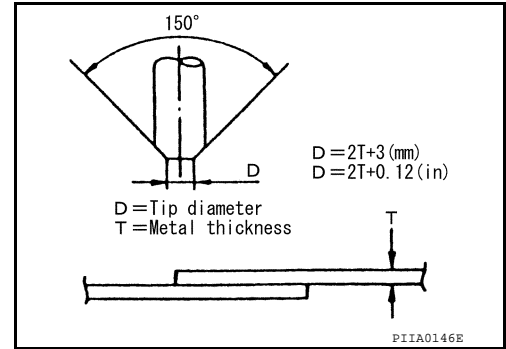

- The panel surfaces must fit flush to each other, leaving no gaps.

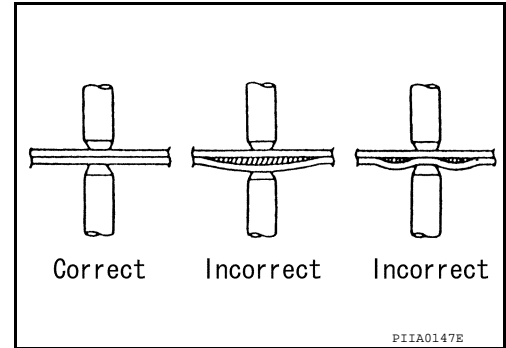

- Follow the specifications for the proper welding pitch.

Unit: mm (in)

Thickness (T)	Minimum pitch (L)
0.6 (0.024)	10 (0.39) or over
0.8 (0.031)	12 (0.47) or over
1.0 (0.039)	18 (0.71) or over
1.2 (0.047)	20 (0.79) or over
1.6 (0.063)	27 (1.06) or over
1.8 (0.071)	31 (1.22) or over

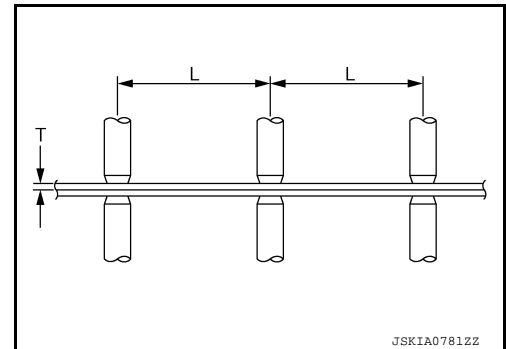

Handling of Ultra High Strength Steel Plate Parts

INFOID:000000008506509

PROHIBITION OF CUT AND CONNECTION

Do not cut and join the lower lock pillar reinforcement (center pillar reinforcement inside frame parts) because its material is high strength steel plate (ultra high strength steel plate). The center pillar reinforcement must be replaced if this part is damaged.

REPAIRING MATERIAL

< PREPARATION >

PREPARATION

REPAIRING MATERIAL

Foam Repair

INFOID:000000008506510

During factory body assembly, foam insulators are installed in certain body panels and locations around the vehicle. Use the following procedure(s) to replace any factory-installed foam insulators.

URETHANE FOAM APPLICATIONS

Use commercially available urethane foam for sealant (foam material) repair of material used on vehicle.

<Urethane foam for foaming agent>

3M™ Automix™ Flexible Foam 08463 or equivalent

Read instructions on product for fill procedures.

Example of foaming agent filling operation procedure:

1. Fill procedures after installation of service part.
 - a. Eliminate foam material remaining on vehicle side.
 - b. Clean area after eliminating form insulator and foam material.
 - c. Install service part.
 - d. Insert nozzle into hole near fill area and fill foam material or fill enough to close gap with the service part.

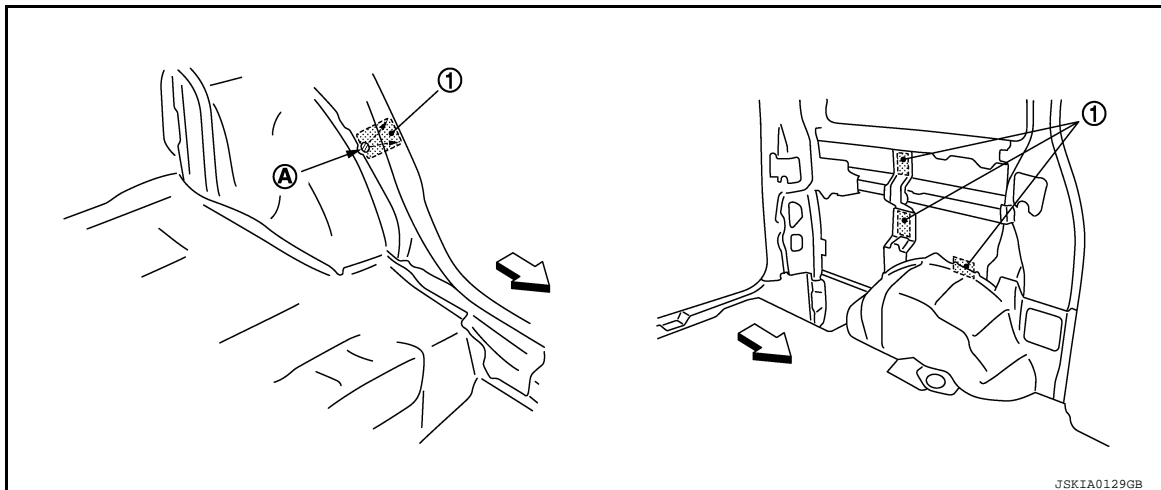

1. Urethane foam

A. Nozzle insert hole

← Front

2. Fill procedures before installation of service part:

- a. Eliminate foam material remaining on vehicle side.
- b. Clean area after eliminating foam insulator and foam material.
- c. Fill with enough foam material on the wheelhouse outer side to close the gap with the service part while avoiding the flange area.

1. Urethane foam

A. Fill while avoiding flange area

← Front

d. Install service part.

NOTE:

Refer to the label on the urethane foam container for information on working times.

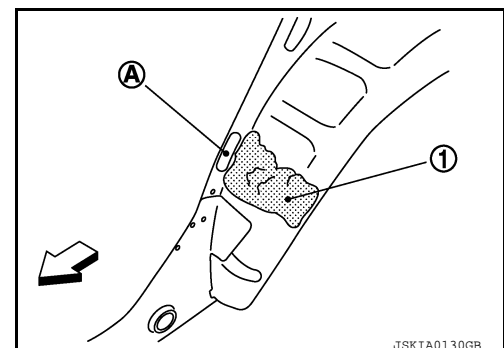

A
B
C
D
E
F
G
H
I
J
L
M
N
O
P

BRM

BODY COMPONENT PARTS

< PREPARATION >

BODY COMPONENT PARTS

Underbody Component Parts

INFOID:000000008506511

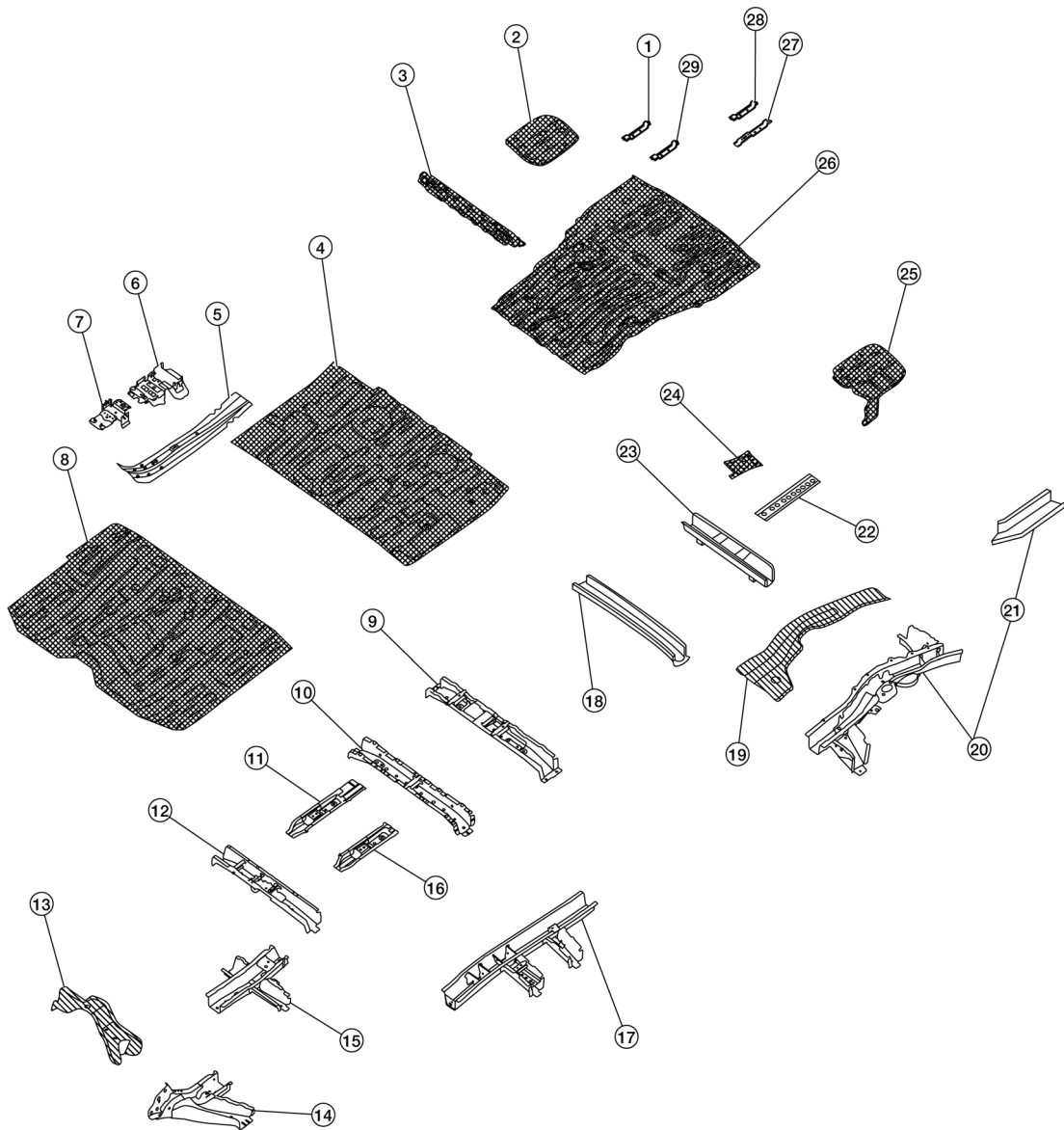

FLOOR AND UNDERBODY



ALKIA2385ZZ

BODY COMPONENT PARTS

< PREPARATION >

-  : Both sided anti-corrosive precoated steel portions
 : High strength steel (HSS) portions
 : Both sided anti-corrosive steel and HSS portions

A

B

Item	Part name	Material	
1.	Front woofer bracket (LH)	—	C
2.	Rear floor side assembly (RH)	SP781B	
3.	Lower seatback support assembly	SP123B	
4.	Rear floor front	SP781B	D
5.	Front side member stiffener (RH, LH)	SP151-1350Hv	
6.	Trim mounting bracket assembly	—	
7.	Instrument stay bracket assembly	—	E
8.	Front floor front	SP781B	
9.	5th crossmember assembly	—	
10.	4th crossmember assembly	—	F
11.	Rear inner belt anchor reinforcement assembly (RH)	—	
12.	3rd crossmember assembly	—	
13.	Front suspension member lower mounting assembly	SP781-440	G
14.	Front side member assembly (RH, LH)	—	
15.	Front side member extension assembly (RH, LH)	—	
16.	Rear inner belt anchor reinforcement assembly (LH)	—	H
17.	Front side member rear extension assembly (RH, LH)	—	
18.	6th crossmember assembly	—	
19.	Rear floor front extension assembly (RH, LH)	—	I
20.	Rear side member assembly (RH, LH)	—	
21.	Rear side member extension assembly (RH, LH)	—	
22.	Rear member center assembly	—	J
23.	7th crossmember assembly	—	
24.	Spare tire mounting bracket	SP781B	
25.	Rear floor side assembly (LH)	SP781B	BRM
26.	Rear floor rear	SP781B	
27.	Rear woofer bracket (LH)	—	
28.	Rear woofer bracket (RH)	—	L
29.	Front woofer bracket (RH)	—	

ENGINE COMPARTMENT

M

N



O

P

BODY COMPONENT PARTS

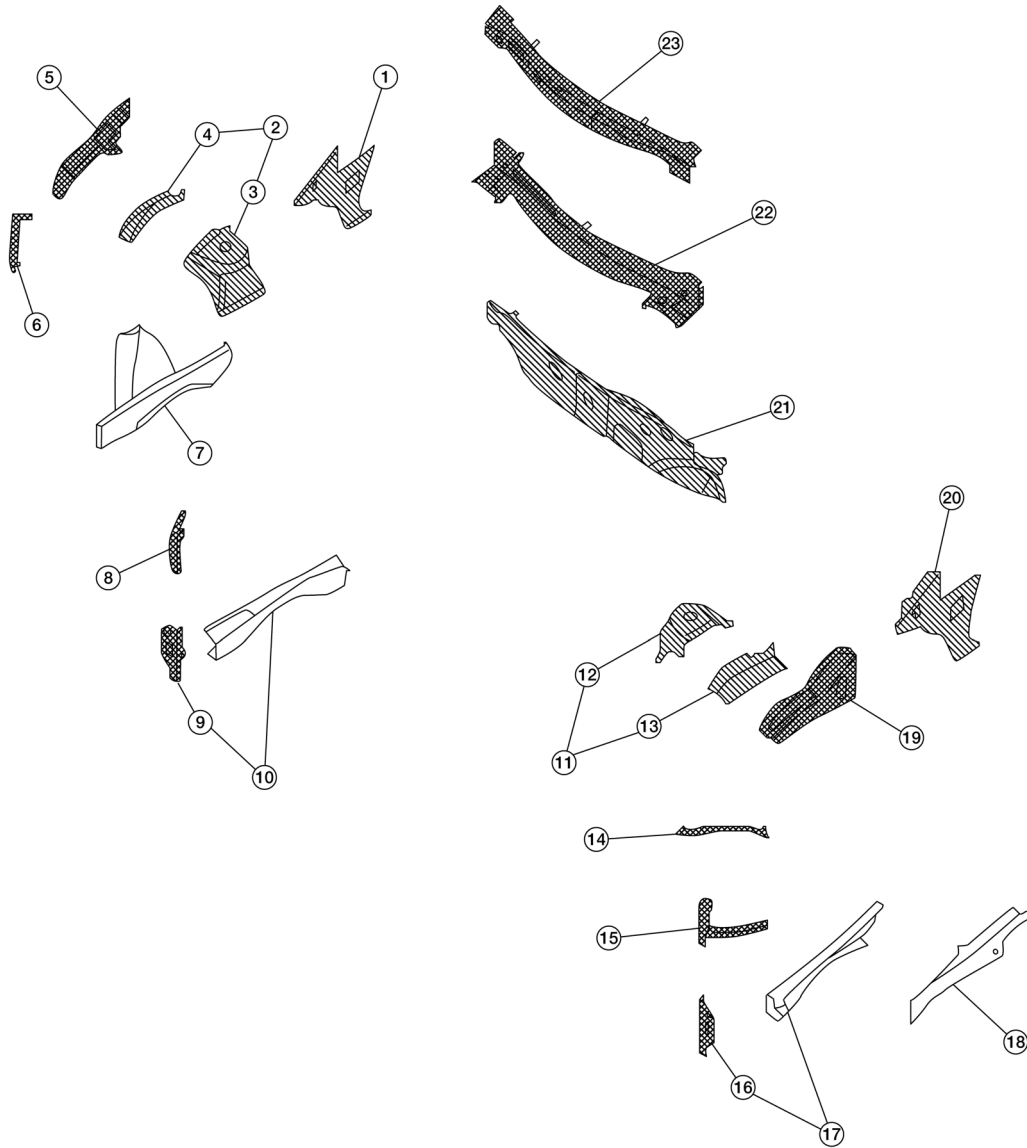
< PREPARATION >



-  : Both sided anti-corrosive pre-coated steel portions
-  : High strength steel (HSS) portions
-  : Both sided anti-corrosive steel and HSS portions

ALKIA2386ZZ

BODY COMPONENT PARTS

< PREPARATION >

Item	Part name	Material	
1.	Dash side assembly (RH)	SP781-390B	A
2.	Hoodledge assembly (RH)	—	
3.	Hoodledge lower assembly (RH)	SP231-440P	B
4.	Upper hoodledge (RH)	SP231-440P	
5.	Hoodledge extension (RH)	SP781B	
6.	Upper radiator core support (RH)	SP782B	C
7.	Front side member closing plate assembly (RH)	—	
8.	Radiator core side support (RH)	—	
9.	Front side member connector (RH)	SP221B	D
10.	Front side member assembly (RH)	—	
11.	Hoodledge assembly (LH)	—	
12.	Hoodledge lower assembly (LH)	SP231-440P	E
13.	Upper hoodledge (LH)	SP231-440P	
14.	Upper radiator core support (LH)	SP782B	
15.	Radiator core side support (LH)	—	F
16.	Front side member connector (LH)	SP221B	
17.	Front side member assembly (LH)	—	
18.	Front side member closing plate assembly (LH)	—	G
19.	Hoodledge extension (LH)	SP781B	
20.	Dash side assembly (LH)	SP781-390B	H
21.	Lower dash assembly	SP781-390B	
22.	Upper dash assembly	SP781B	
23.	Cowl assembly	—	I

BRM

L

M

N

O

P

BODY COMPONENT PARTS



< PREPARATION >

Body Component Parts

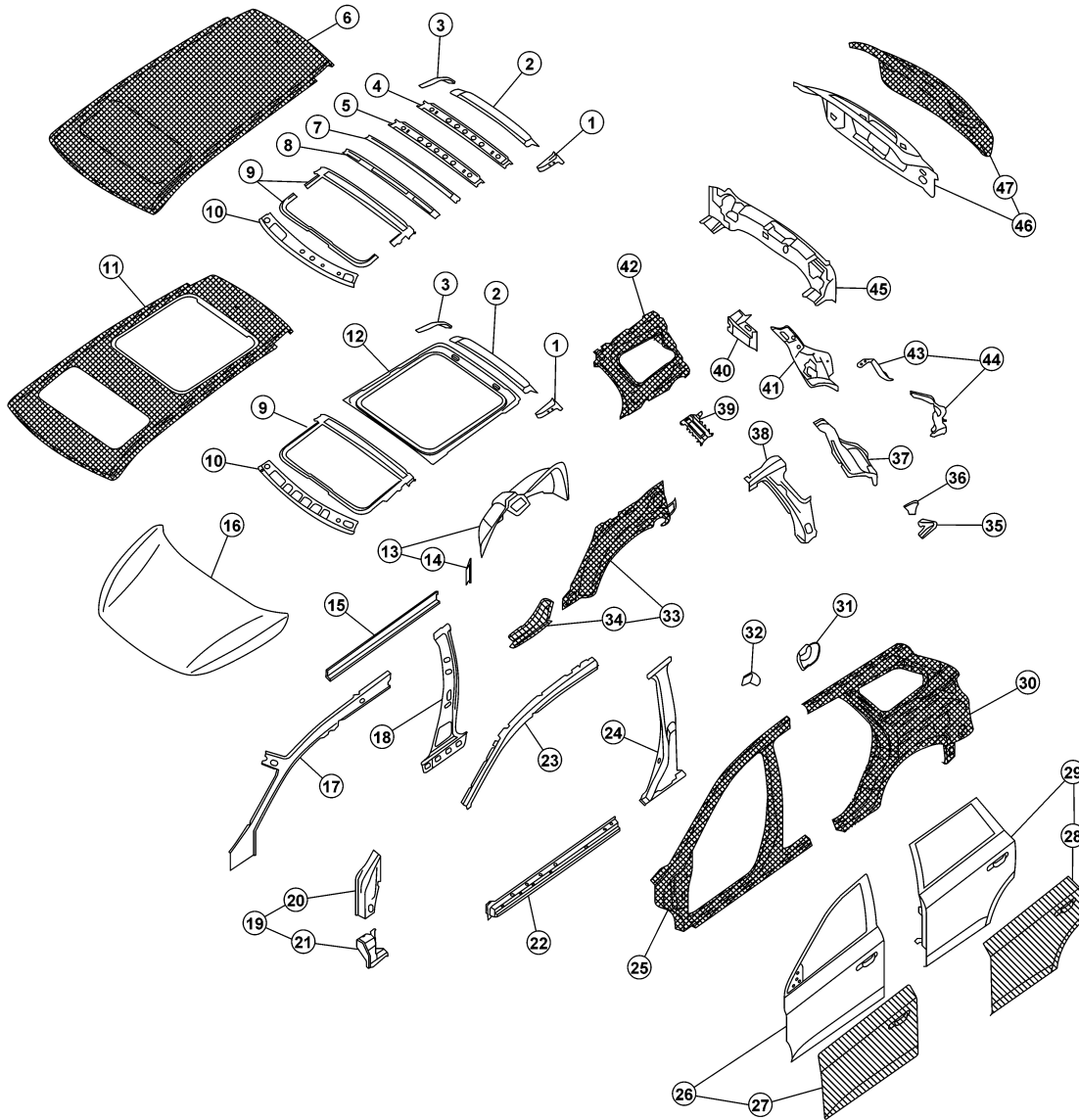
INFOID:00000008506512



ALKIA27452Z

-  : Both sided anti-corrosive pre-coated steel portions
-  : High strength steel (HSS) portions
-  : Both sided anti-corrosive steel and HSS portions

BODY COMPONENT PARTS

< PREPARATION >

Item	Part name	Material	
1.	Roof corner reinforcement (LH)	SP121BQ	A
2.	Rear roof rail assembly	—	
3.	Roof corner reinforcement (RH)	SP121BQ	B
4.	6th roof bow, standard roof	SP129BQ	
5.	5th roof bow, standard roof	SP129BQ	
6.	Standard roof	SP121AQ	C
7.	4th roof bow, standard roof	SP129BQ	
8.	3rd roof bow, standard roof	SP123BQ	
9.	Roof reinforcement assembly, standard roof	SP121BQ	D
10.	Front roof rail assembly	—	
11.	Panoramic roof	SP121AQ	
12.	Rear roof reinforcement assembly	SP121BQ	E
13.	Rear wheel inner assembly (RH, LH)	—	
14.	Rear wheel inner front extension	SP781B	
15.	Inner sill (RH, LH)	RP783-980	F
16.	Hood assembly	—	
17.	Inner roof side rail complete (RH, LH)	—	
18.	Center pillar inner (RH, LH)	SP153-980, SP783-590Q	G
19.	Front hinge pillar reinforcement assembly (RH, LH)	—	
20.	Front pillar upper hinge brace (RH, LH)	SP153-590Q	
21.	Front pillar lower hinge brace (RH, LH)	SP152-440Q	H
22.	Outer sill reinforcement assembly (RH, LH)	—	
23.	Roof side outer reinforcement assembly (RH, LH)	—	
24.	Center pillar reinforcement (RH, LH)	—	I
25.	Front body side outer (RH, LH)	SP782AMJQ	
26.	Front door assembly (RH, LH)	—	
27.	Front door outer (RH, LH)	SP785-340AMQ	J
28.	Rear door outer (RH, LH)	SP785-340AMQ	
29.	Rear door assembly (RH, LH)	—	
30.	Rear body side outer	SP782AMJQ	BRM
31.	Fuel filler base	SP1212BQ	
32.	Striker retainer (RH, LH)	SP121BQ	
33.	Rear wheel outer assembly	—	L
34.	Rear outer sill reinforcement assembly (RH, LH)	SP782-440Q	
35.	Rear fender cover lower (RH, LH)	SP782AMJQ	M
36.	Rear fender cover upper (RH, LH)	SP782AMJQ	
37.	Outer back pillar assembly (RH, LH)	—	
38.	Rear pillar inner reinforcement assembly (RH, LH)	—	
39.	Rear pillar seat belt anchor assembly (RH, LH)	SP231-370Q	N
40.	Rear fender brace (RH, LH)	SP221BQ	
41.	Inner back pillar assembly (RH, LH)	—	
42.	Inner rear pillar (RH, LH)	—	O
43.	Main back pillar assembly (RH, LH)	SP121BQ	
44.	Rear combination lamp base assembly (RH, LH)	—	
45.	Rear panel assembly	—	P
46.	Back door inner assembly	—	
47.	Back door outer assembly	SP783	

CORROSION PROTECTION

< REMOVAL AND INSTALLATION >

REMOVAL AND INSTALLATION

CORROSION PROTECTION

Description

INFOID:000000008506513

To provide improved corrosion prevention, the following anti-corrosive measures have been implemented in NISSAN production plants. When repairing or replacing body panels, it is necessary to use the same anti-corrosive measures.

Anti-Corrosive Precoated Steel (Galvannealed Steel)

To improve repairability and corrosion resistance, a new type of anti-corrosive precoated steel sheet has been adopted, replacing conventional zinc-coated steel sheet.

Galvannealed steel is electroplated and heated to form zinc-iron alloy, which provides excellent and long term corrosion resistance with cationic electrodeposition primer.

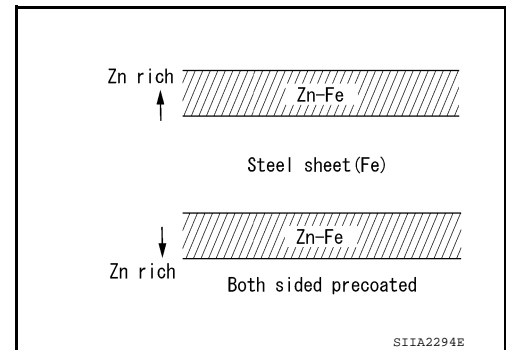

Nissan Genuine Service Parts are fabricated from galvannealed steel. Therefore, it is recommended that GENUINE NISSAN PARTS or equivalent be used for panel replacement to maintain the anti-corrosive performance built into the vehicle at the factory.

Phosphate Coating Treatment and Cationic Electrodeposition Primer

A phosphate coating treatment and a cationic electrodeposition primer, which provide excellent corrosion protection, are employed on all body components.

CAUTION:

Confine paint removal during welding operations to an absolute minimum.

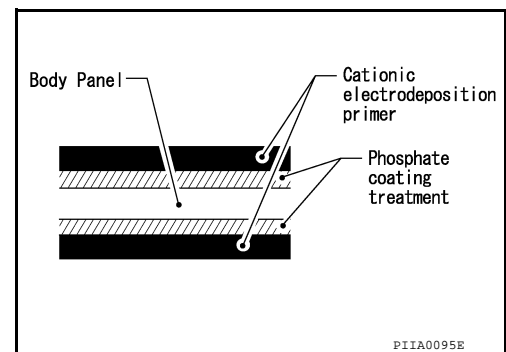

Nissan Genuine Service Parts are also treated in the same manner. Therefore, it is recommended that GENUINE NISSAN PARTS or equivalent be used for panel replacement to maintain anti-corrosive performance built into the vehicle at the factory.

Anti-Corrosive Wax

INFOID:000000008506514

To improve corrosion resistance, anti-corrosive wax is applied inside the body sill and inside other closed sections. Accordingly, when replacing these parts, be sure to apply anti-corrosive wax to the appropriate areas of the new parts. Select an excellent anti-corrosive wax which will penetrate after application and has a long shelf life.

CORROSION PROTECTION

< REMOVAL AND INSTALLATION >

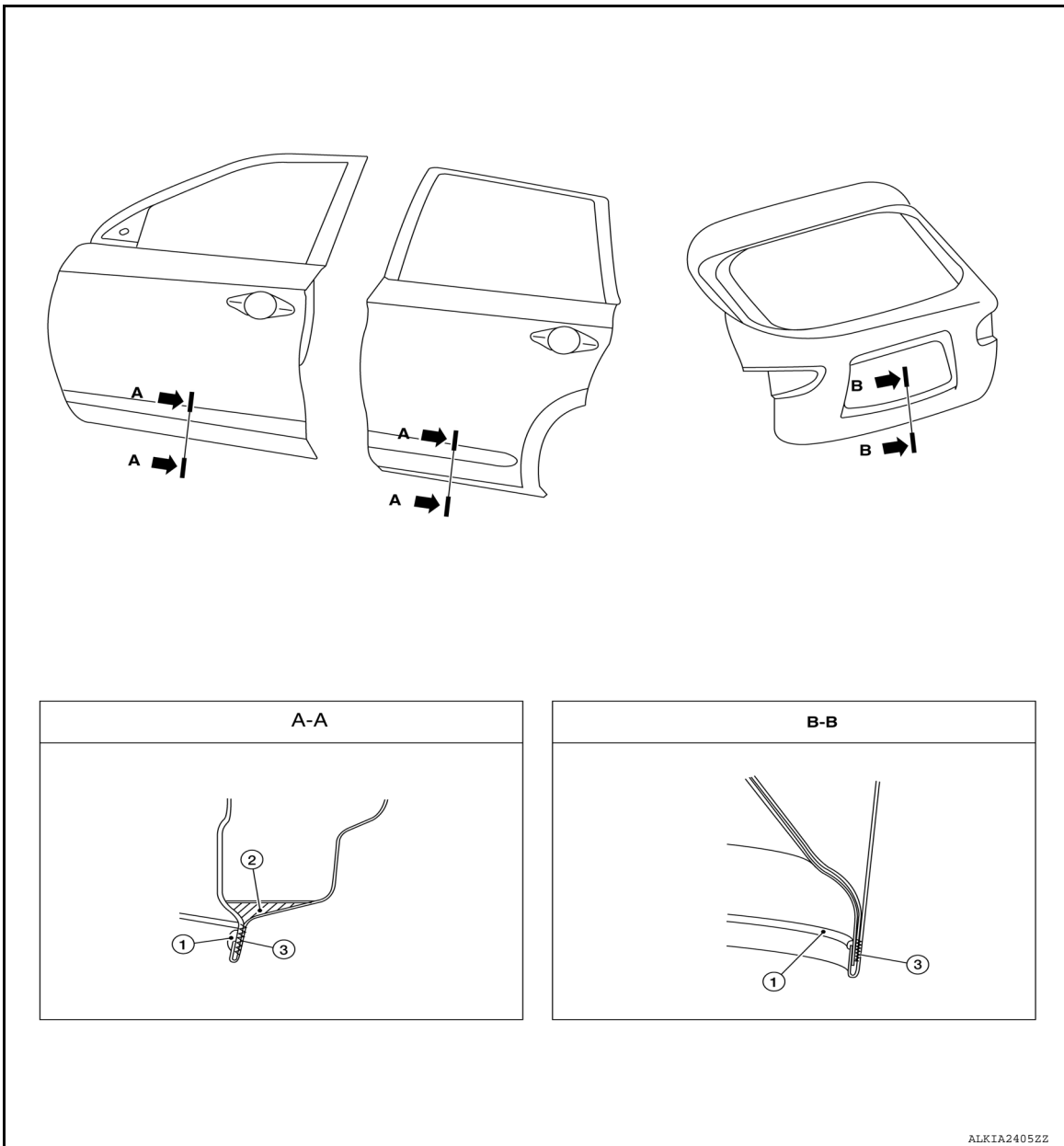

1. Body caulk

2. Anti-corrosive wax

3. Panel adhesive

Undercoating

INFOID:000000008506515

The underside of the floor and wheelhouse are undercoated to prevent rust, vibration, noise and stone chipping. Therefore, when such a panel is replaced or repaired, apply undercoating to that part. Use an undercoating which is rust preventive, soundproof, vibration-proof, shock-resistant, adhesive, and durable.

Precautions in Undercoating

1. Do not apply undercoating unless specified. Avoid areas such as the areas above the muffler and three-way catalyst which are subjected to heat.
2. Do not undercoat the exhaust pipe or other parts which become hot.
3. Do not undercoat rotating parts.
4. Apply bitumen wax after applying undercoating.
5. After putting seal on the vehicle, put undercoating on it.

A

B

C

D

E

F

G

H

I

J

BRM

L

M

N

O

P

CORROSION PROTECTION

< REMOVAL AND INSTALLATION >

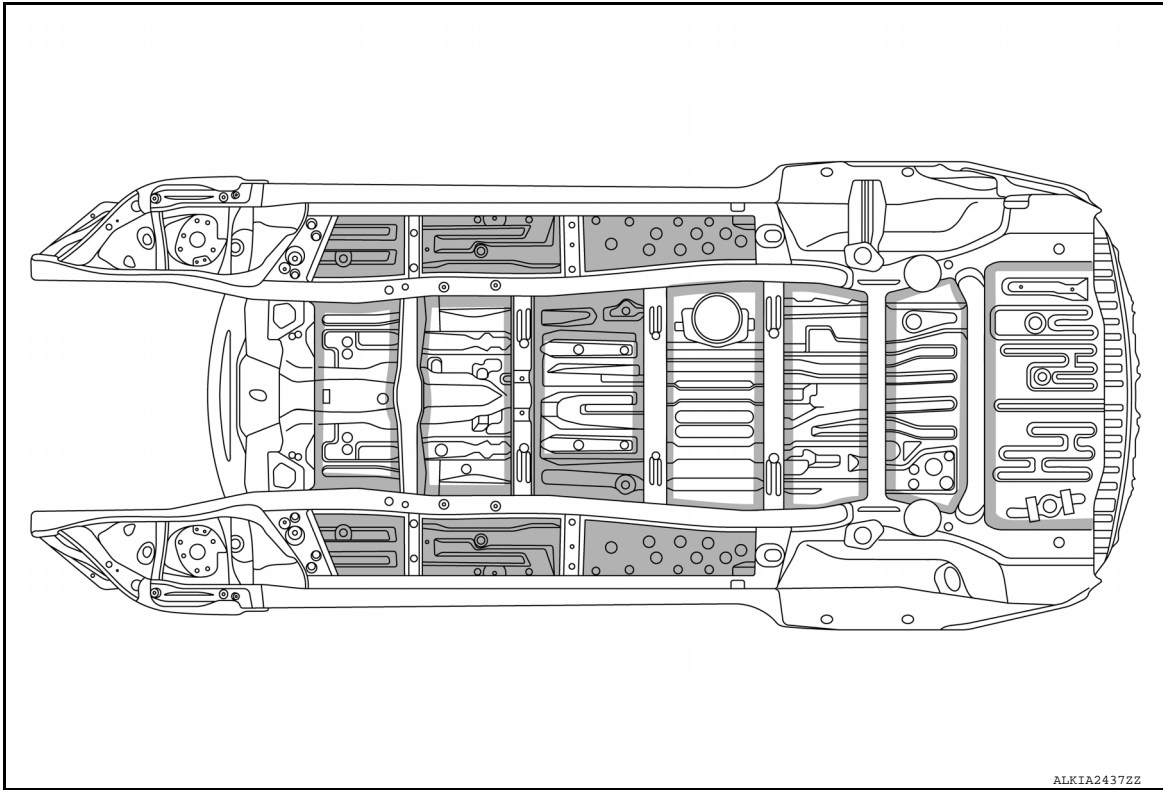

Undercoated areas are shaded.

BODY SEALING

< REMOVAL AND INSTALLATION >

BODY SEALING

Description

INFOID:000000008506516

The following figure shows the areas which are sealed at the factory. Sealant which has been applied to these areas should be smooth and free from cuts or gaps. Care should be taken not to apply an excess amount of sealant and not to allow other unaffected parts to come into contact with the sealant.

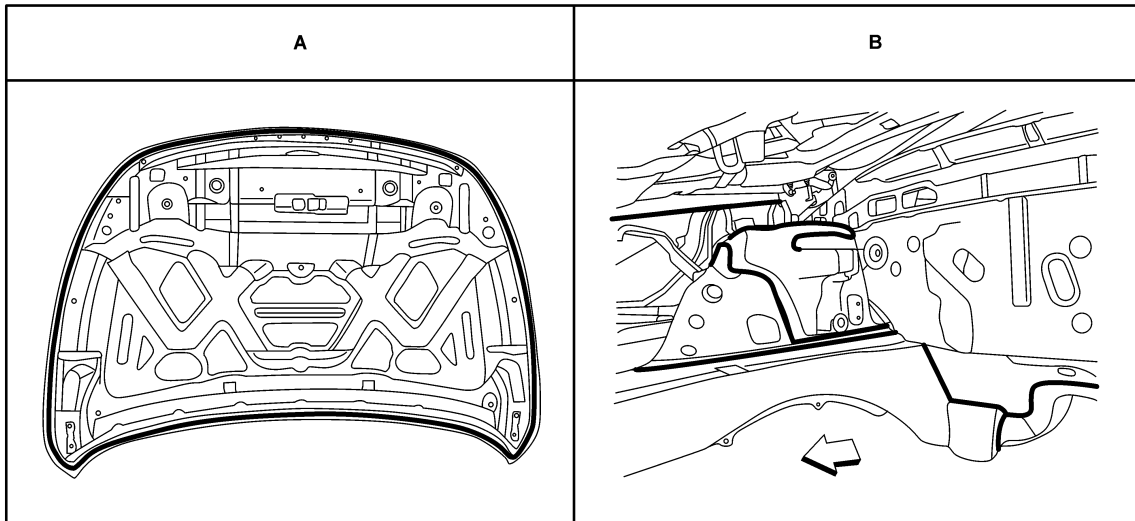
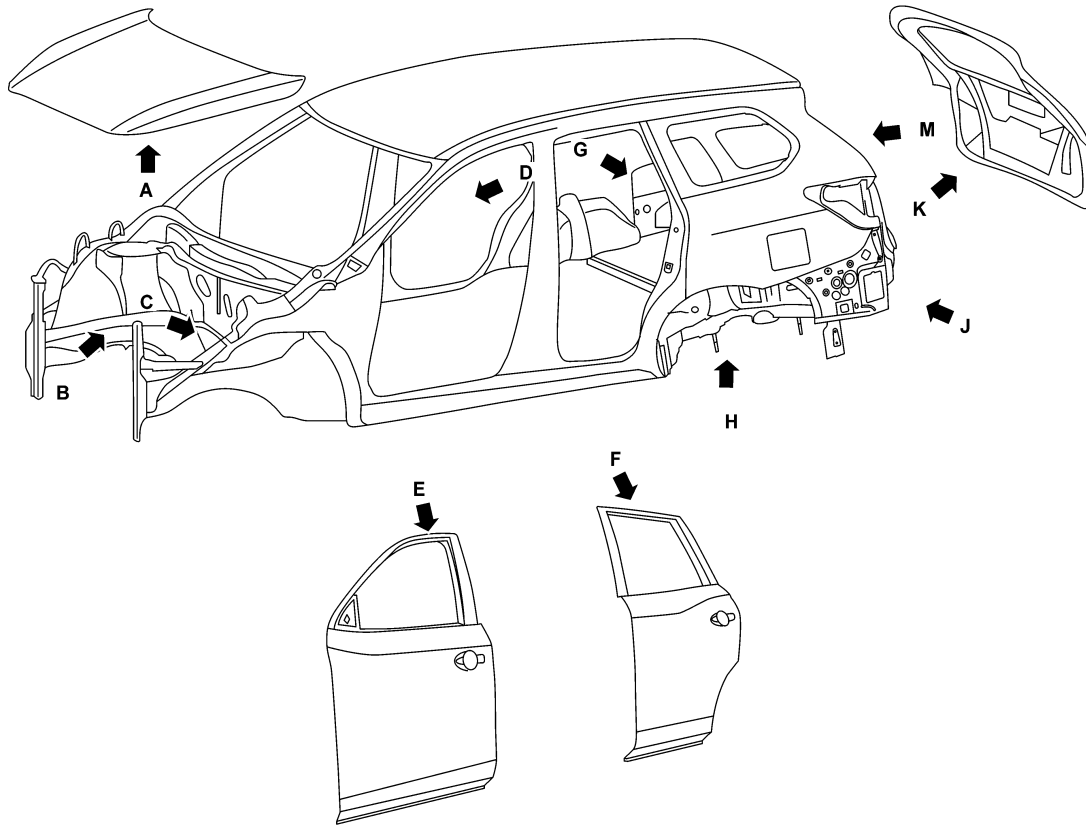

ALKIA27492Z

A
B
C
D
E
F
G
H
I
J
L
M
N
O
P

BRM

BODY SEALING

< REMOVAL AND INSTALLATION >

↩ Front

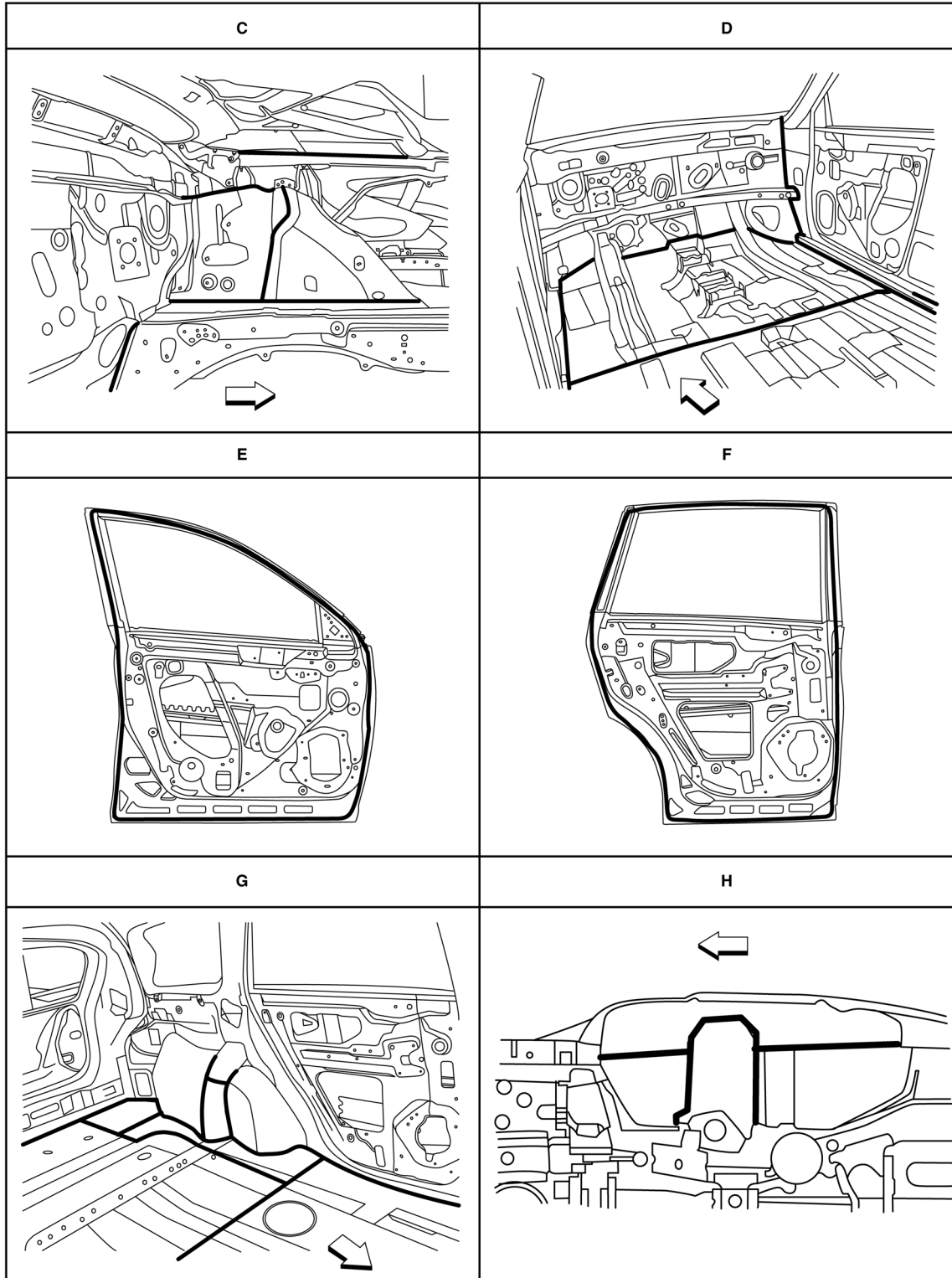

AWK1A2086ZZ

↩ Front

BODY SEALING

< REMOVAL AND INSTALLATION >

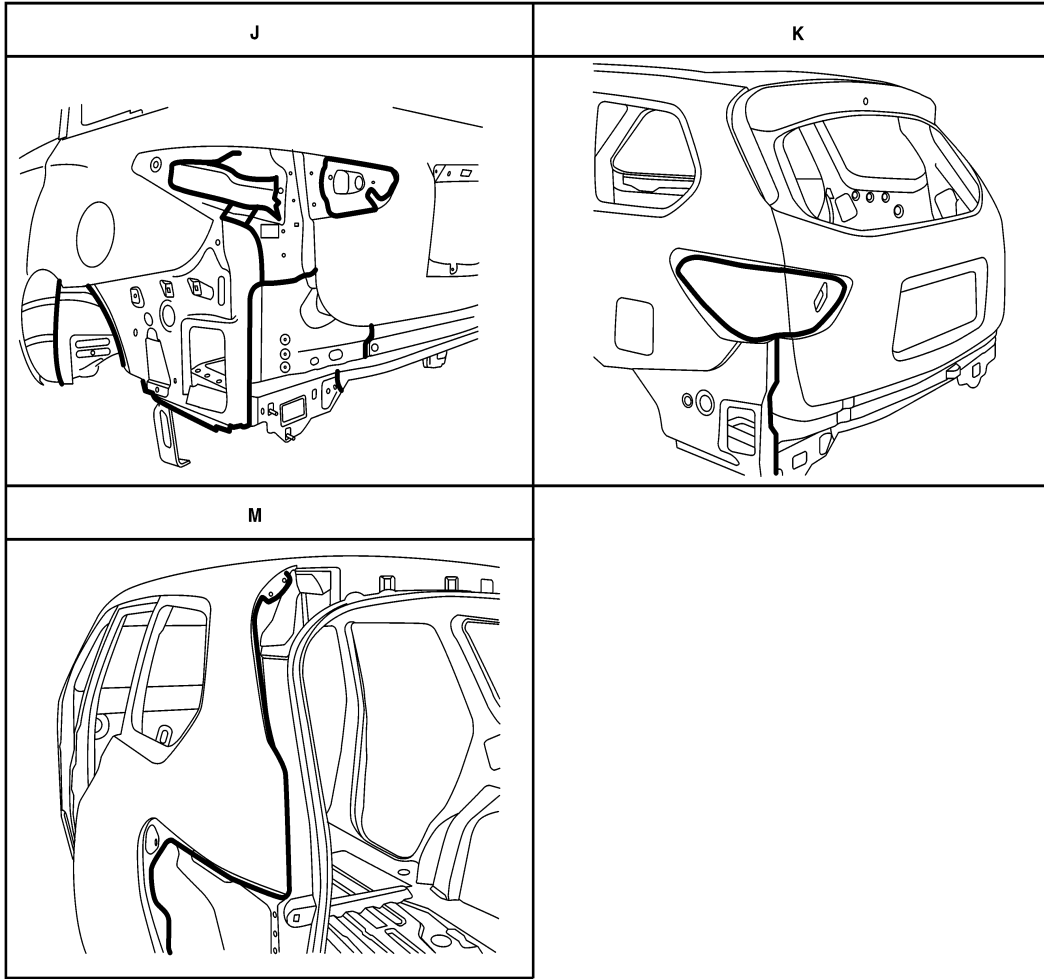

A
B
C
D
E
F
G
H
I
J

BRM

L
M
N
O
P

ALKIA28782Z

BODY CONSTRUCTION

< REMOVAL AND INSTALLATION >

BODY CONSTRUCTION

Body Construction

INFOID:000000008506517

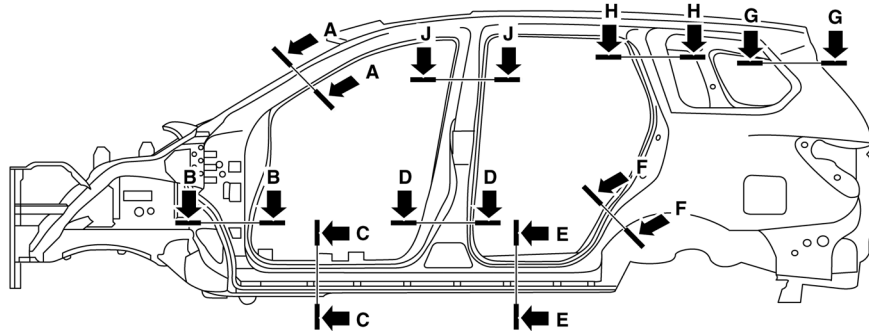

<p style="text-align: center;">A-A</p>	<p style="text-align: center;">B-B</p>	<p style="text-align: center;">C-C</p>
<p style="text-align: center;">D-D</p>	<p style="text-align: center;">E-E</p>	<p style="text-align: center;">F-F</p>
<p style="text-align: center;">G-G</p>	<p style="text-align: center;">H-H</p>	<p style="text-align: center;">J-J</p>

ALKIA27482Z

- | | | |
|--------------------|---|-------------------------------------|
| 1. Body side outer | 2. Front pillar inner upper | 3. Upper front pillar reinforcement |
| 4. Dash side inner | 5. Front hinge pillar lower reinforcement | 6. Outer sill reinforcement |
| 7. Inner sill | 8. Center pillar reinforcement | 9. Inner center pillar |

BODY CONSTRUCTION

< REMOVAL AND INSTALLATION >

- | | | |
|------------------------------|---------------------------------|-------------------------------------|
| 10. Rear sill assembly | 11. Rear wheel housing assembly | 12. Back pillar inner reinforcement |
| 13. Roof rail brace assembly | 14. Back pillar inner | 15. Rear pillar inner reinforcement |

A

B

C

D

E

F

G

H

I

J

BRM

L

M

N

O

P

REPLACEMENT OPERATIONS

< REMOVAL AND INSTALLATION >

REPLACEMENT OPERATIONS

Description

INFOID:000000008506518

This section is prepared for technicians who have attained a high level of skill and experience in repairing collision-damaged vehicles and also use modern service tools and equipment. Persons unfamiliar with body repair techniques should not attempt to repair collision-damaged vehicles by using this section.







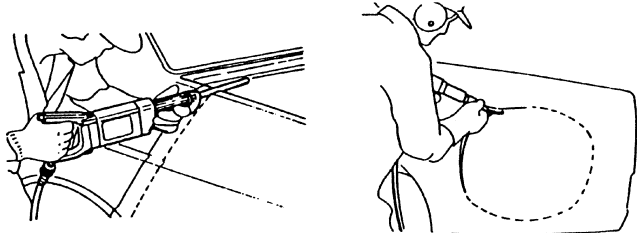

Technicians are also encouraged to read Body Repair Manual (Fundamentals) in order to ensure that the original functions and quality of the vehicle can be maintained. The Body Repair Manual (Fundamentals) contains additional information, including cautions and warnings, that are not including in this manual. Technicians should refer to both manuals to ensure proper repairs.

Please note that this information is prepared for worldwide usage, and as such, certain procedures might not apply in some regions or countries.

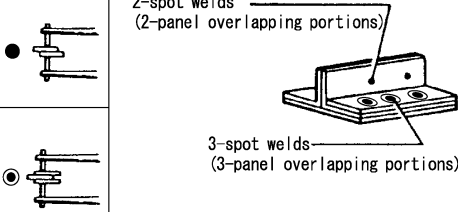
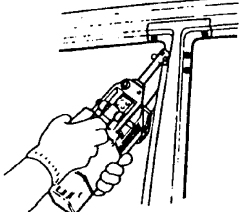
REPLACEMENT OPERATIONS

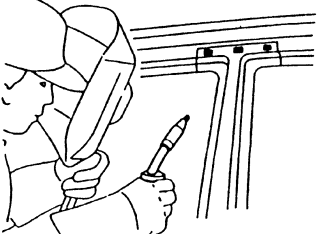
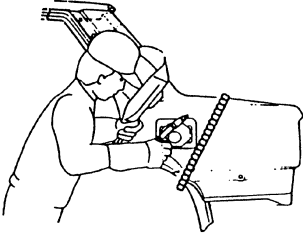
< REMOVAL AND INSTALLATION >

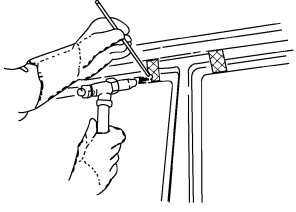
The symbols used in this section for cutting and welding / brazing operations are shown below.

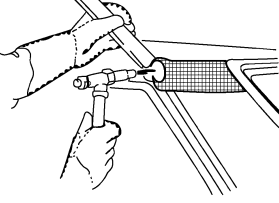
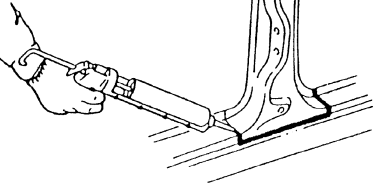
 Saw cut or air chisel cut		
Spot weld  2-spot welds  3-spot welds	 2-spot welds (2-panel overlapping portions) 3-spot welds (3-panel overlapping portions)	
 MIG plug weld  MIG seam weld/ Point weld		
 Brazing		
 Soldering		
Sealing		

A
B
C
D
E
F
G
H
I
J
BRM
L
M
N
O
P

PIIA0149E

REPLACEMENT OPERATIONS

< REMOVAL AND INSTALLATION >

- Front pillar butt joint can be determined anywhere within shaded area as shown in the figure. The best location for the butt joint is at position A due to the construction of the vehicle. Refer to the front pillar section.

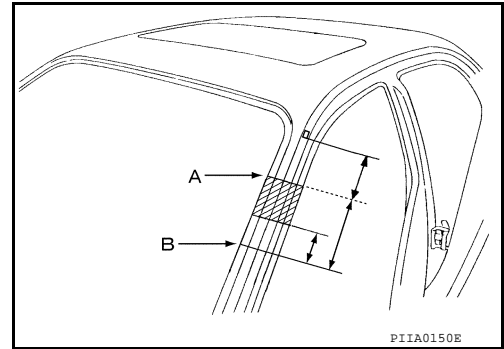

- Determine cutting position and record distance from the locating indent. Use this distance when cutting the service part. Cut outer front pillar over 60 mm (2.4 in) above inner front pillar cut position.

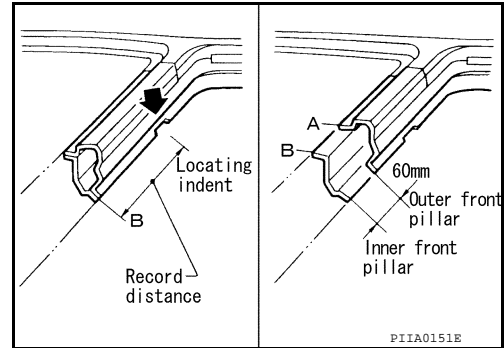

- Prepare a cutting jig to make the outer pillar easier to cut. Also, this will permit the service part to be accurately cut at the joint position.

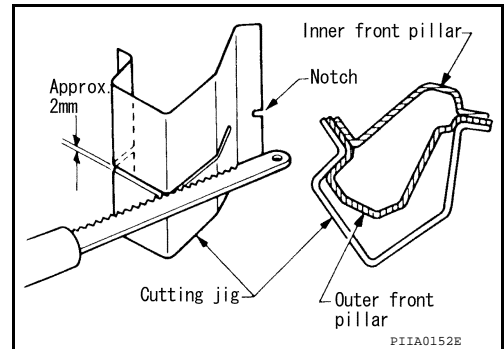

- An example of cutting operation using a cutting jig is as follows:

1. Mark cutting lines.
A: Cut position of outer pillar
2. Align cutting line with notch on jig. Clamp jig to pillar.
3. Cut outer pillar along groove of jig. (At position A)
4. Remove jig and cut remaining portions.

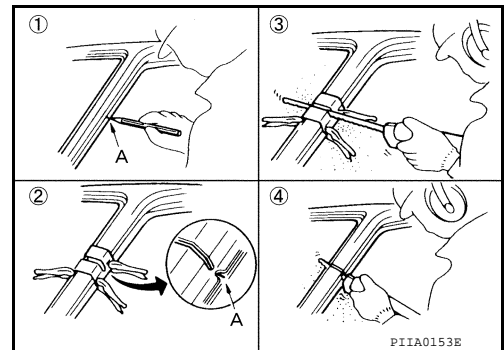

REPLACEMENT OPERATIONS

< REMOVAL AND INSTALLATION >

Hoodledge

INFOID:000000008506519

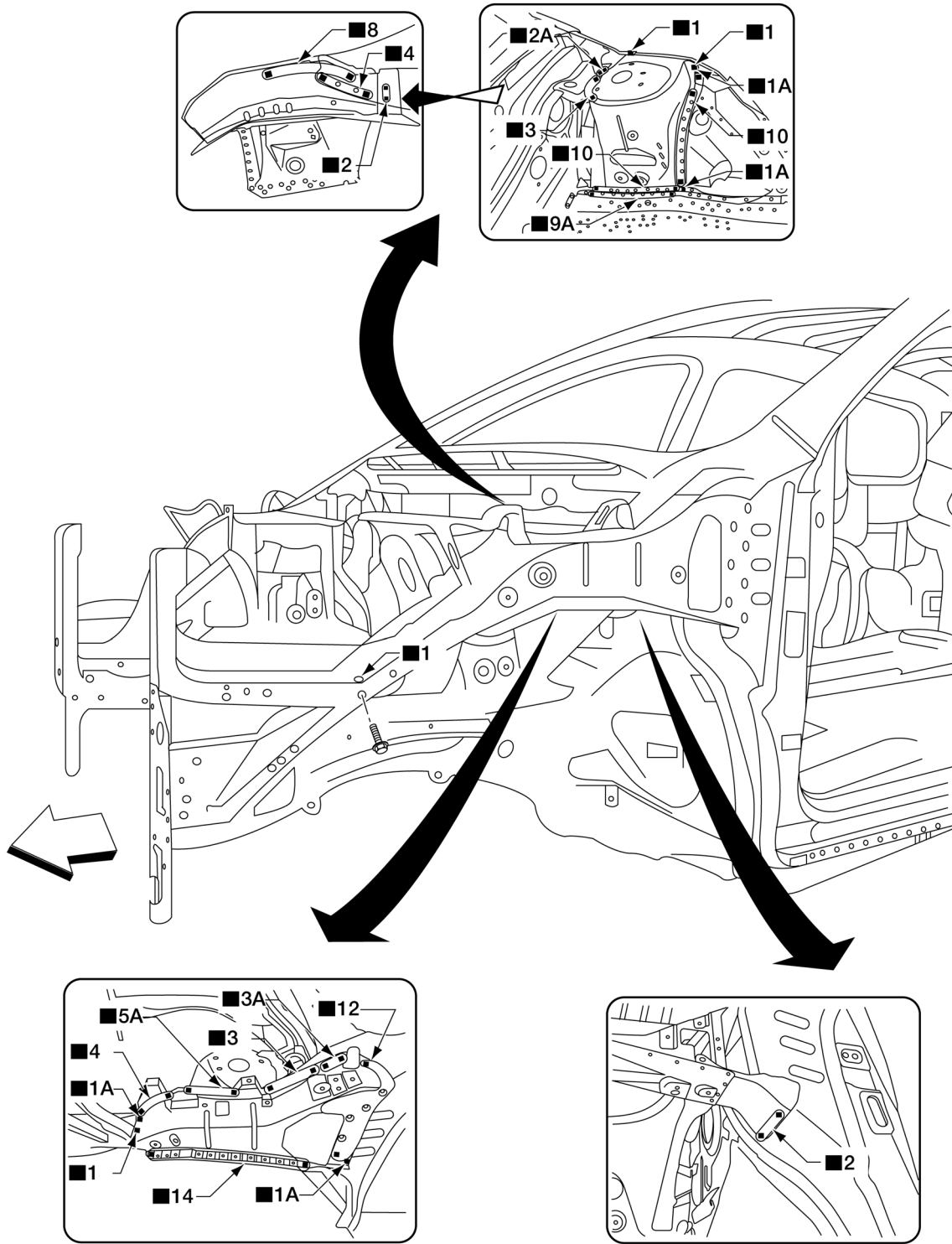

A
B
C
D
E
F
G
H
I
J
K
L
M
N
O
P

BRM

Replacement parts

- Front suspension spring support
- Hoodledge reinforcement
- Upper radiator core support

⇐ Front

ALKIA2750ZZ

REPLACEMENT OPERATIONS

< REMOVAL AND INSTALLATION >

Front Side Member (Partial Replacement)

INFOID:00000008506520

Work after the hoodledge has been removed.

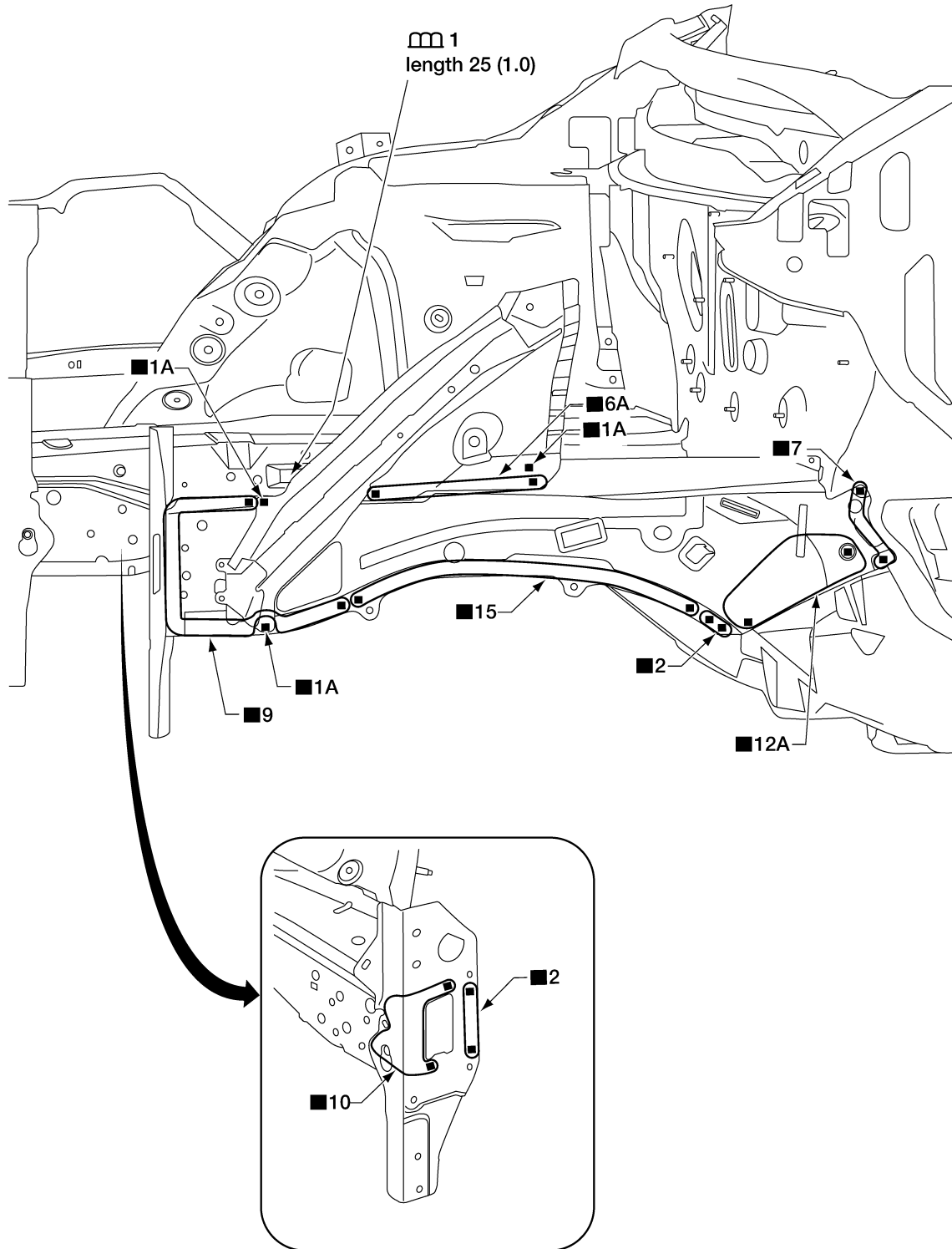

AWKIA2143ZZ

Unit: mm (in)

Replacement parts

- Front side member
- Closing plate assembly
- Radiator core side support

REPLACEMENT OPERATIONS

< REMOVAL AND INSTALLATION >

Front Pillar

INFOID:000000008506521

OUTER

- Work after the upper hoodledge has been removed.

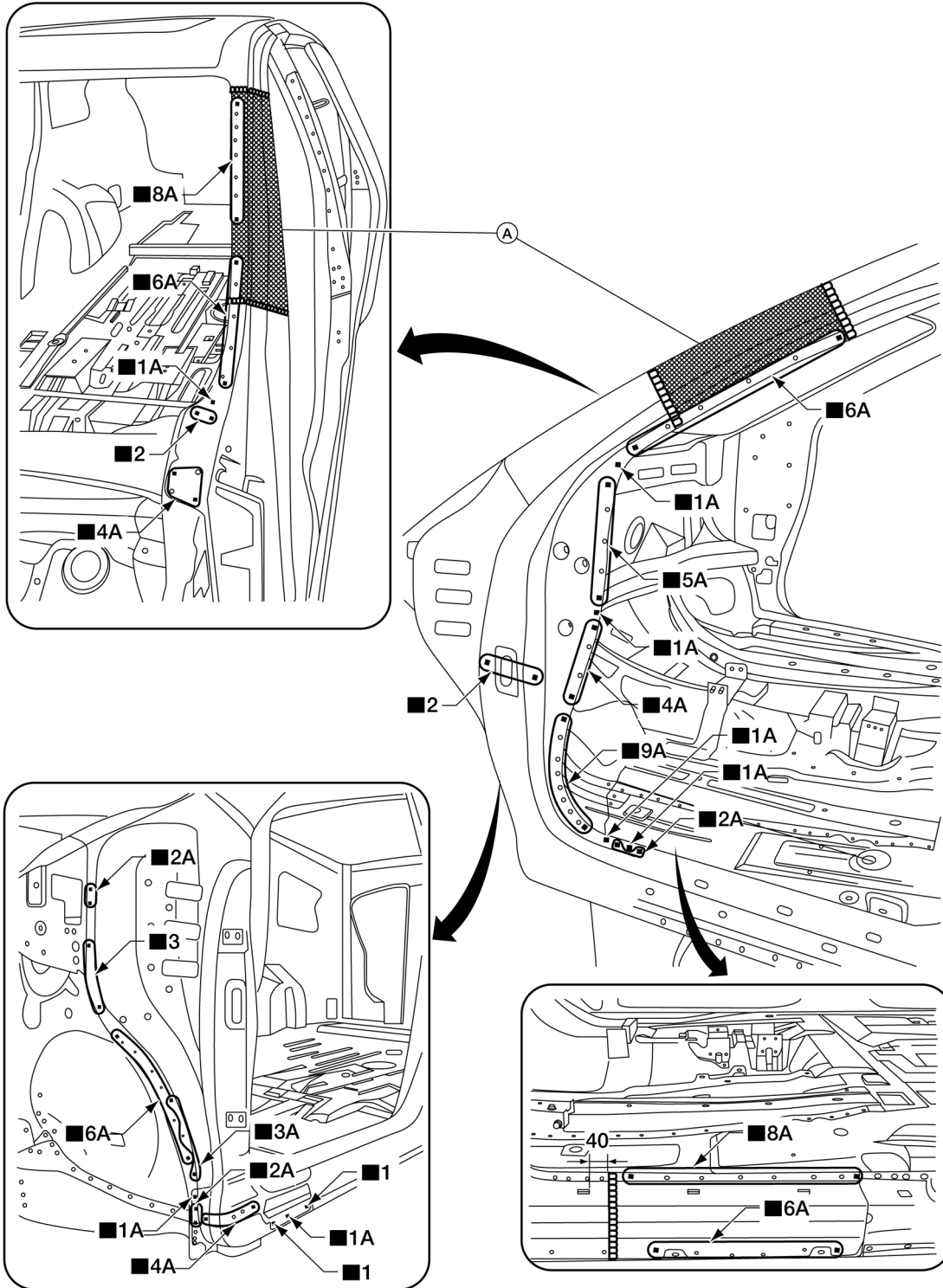

A
B
C
D
E
F
G
H
I
J
K
L
M
N
O
P

BRM

Replacement parts

- Front pillar section of front body side outer A. Recommended sectioning location

ALKIA2752ZZ

REPLACEMENT OPERATIONS

< REMOVAL AND INSTALLATION >

HINGE PILLAR BRACE

Upper

- Work after front pillar outer has been removed.

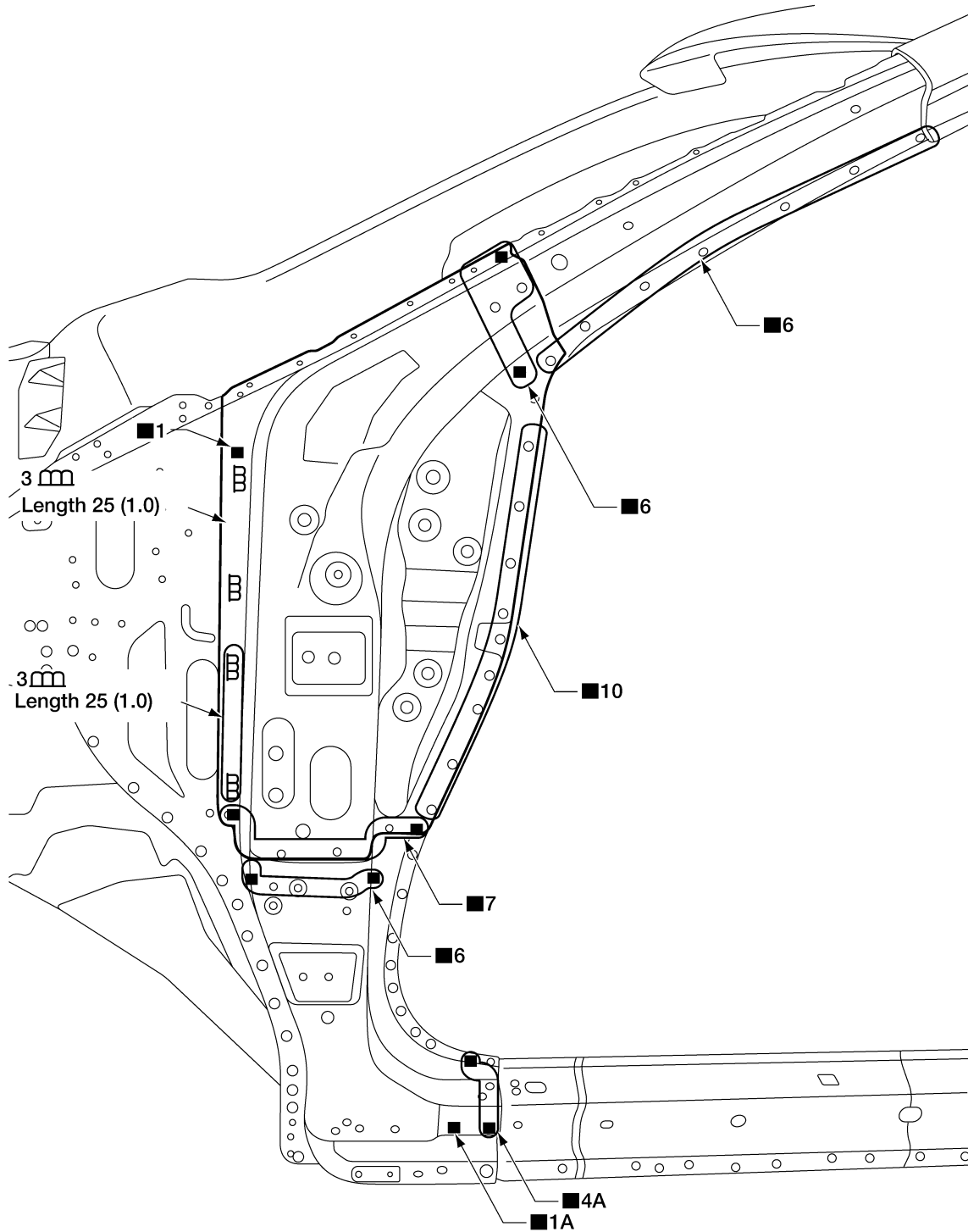

AWKIA2144ZZ

Unit: mm (in)

Replacement parts

- Front pillar upper hinge brace

Lower

REPLACEMENT OPERATIONS

< REMOVAL AND INSTALLATION >

- Work after hinge pillar upper has been removed.

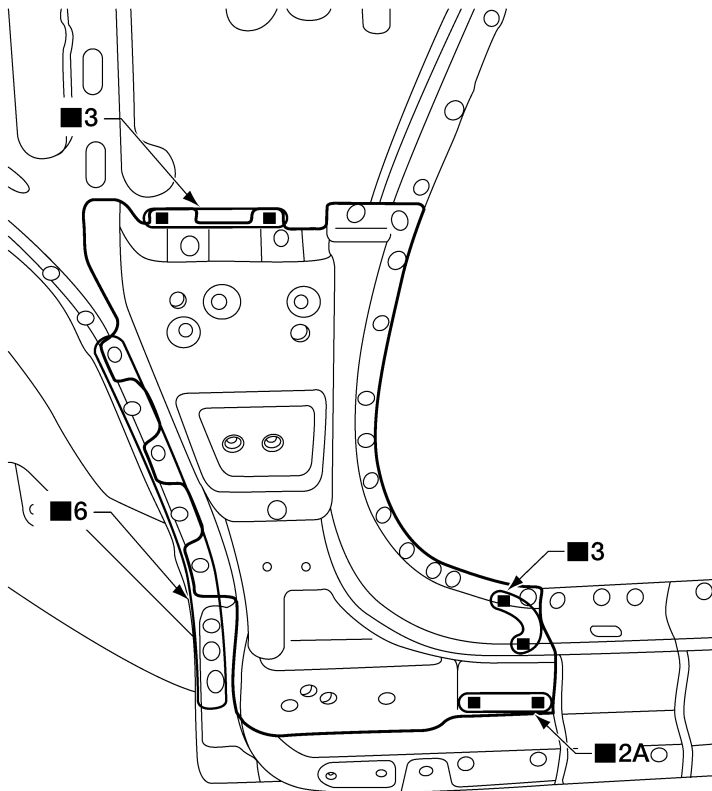
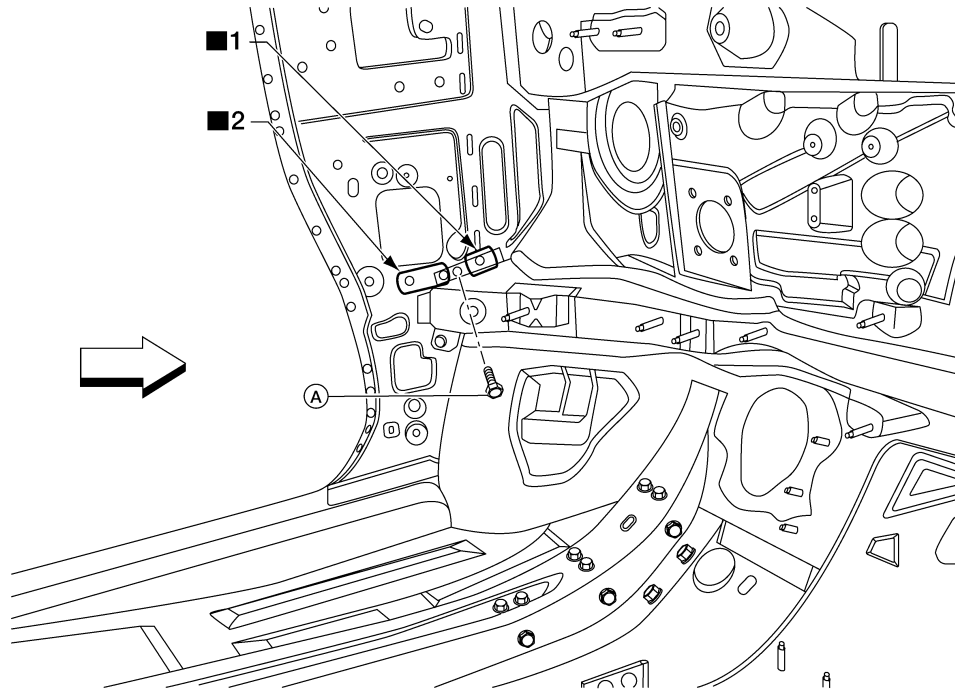

Replacement parts

- Front pillar lower hinge brace

A. Bolt

← Front

ALKIA27562Z

A
B
C
D
E
F
G
H
I
J
K
L
M
N
O
P

BRM

REPLACEMENT OPERATIONS

< REMOVAL AND INSTALLATION >

Dash Side

INFOID:00000008506522

Work after the front pillar portion of body side inner reinforcement and the front pillar lower hinge brace have been removed.

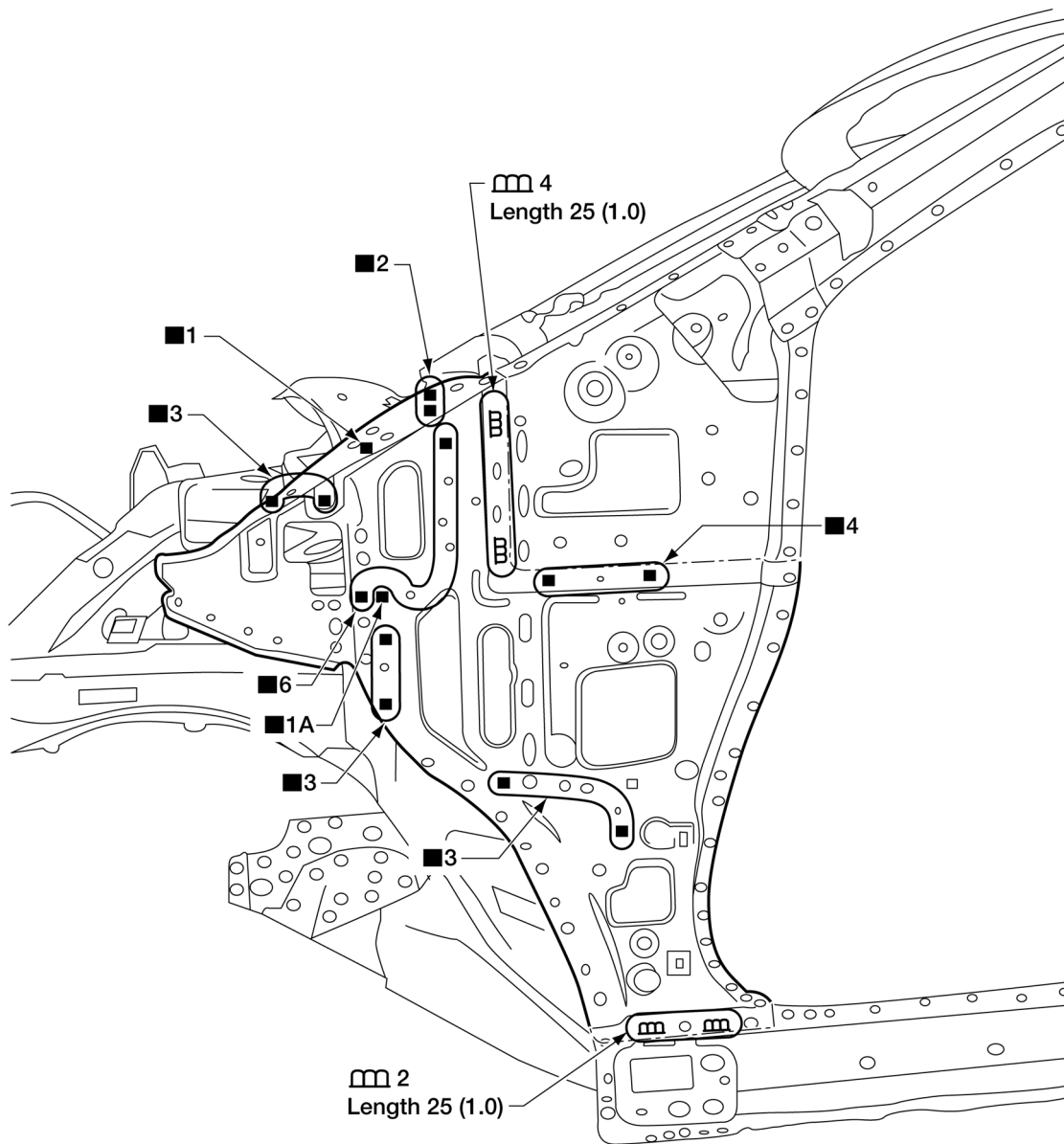

ALKIA2522ZZ

Unit: mm (in)

Replacement parts

- Dash side

REPLACEMENT OPERATIONS

< REMOVAL AND INSTALLATION >

Center Pillar

INFOID:000000008506523

OUTER

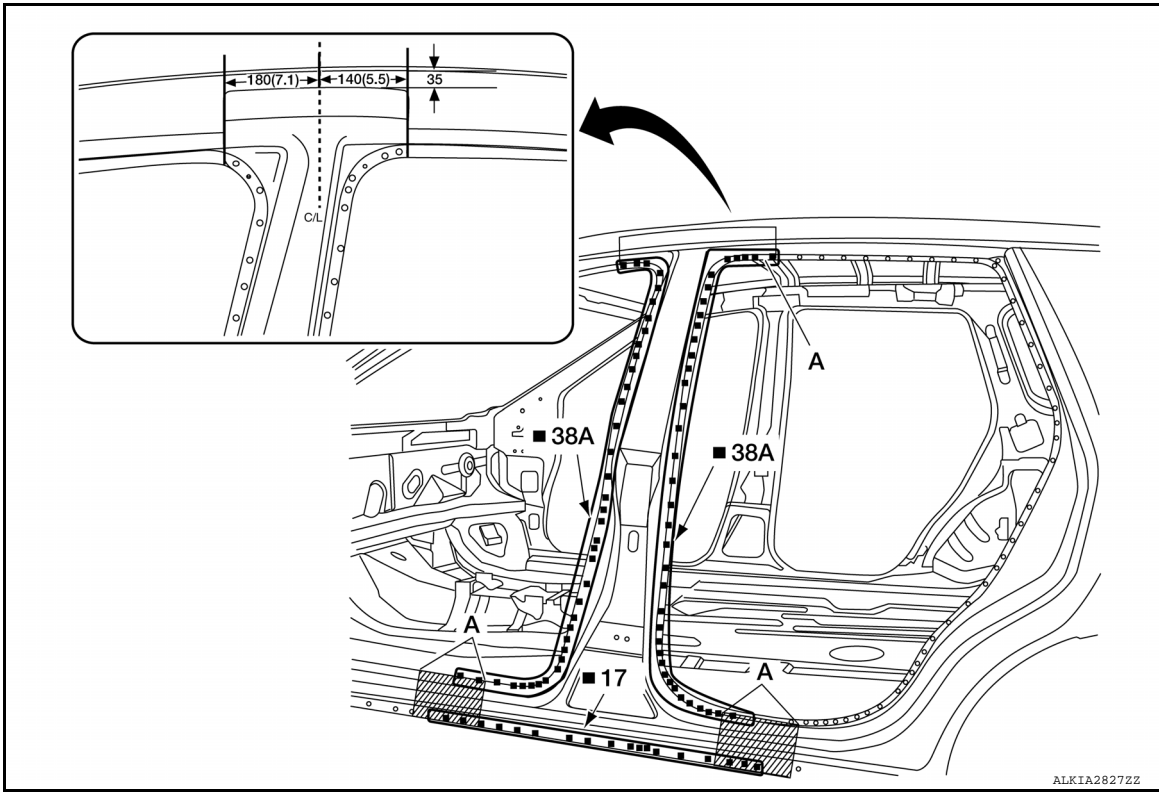

Unit: mm (in)

Replacement parts

- Center pillar portion of front body side outer
- A. Recommended sectioning area

REINFORCEMENT

Work after center pillar portion of front body side outer has been removed.

A
B
C
D
E
F
G
H
I
J
L
M
N
O
P

BRM

REPLACEMENT OPERATIONS

< REMOVAL AND INSTALLATION >

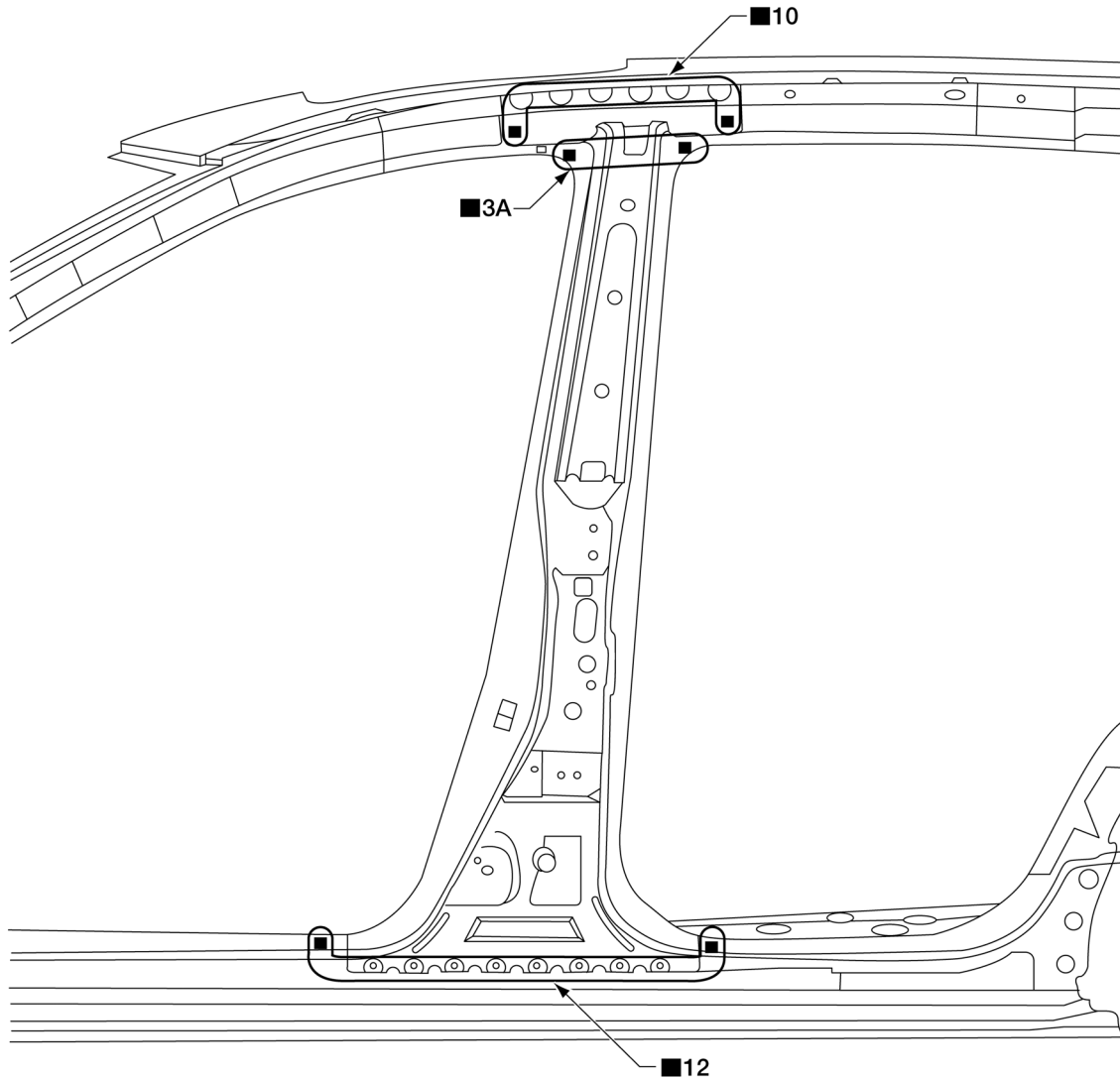

ALKIA2452ZZ

Replacement parts

- Center pillar reinforcement

Outer Sill Reinforcement

INFOID:000000008506524

Work after the front pillar lower hinge brace and the center pillar reinforcement have been removed.

REPLACEMENT OPERATIONS

< REMOVAL AND INSTALLATION >

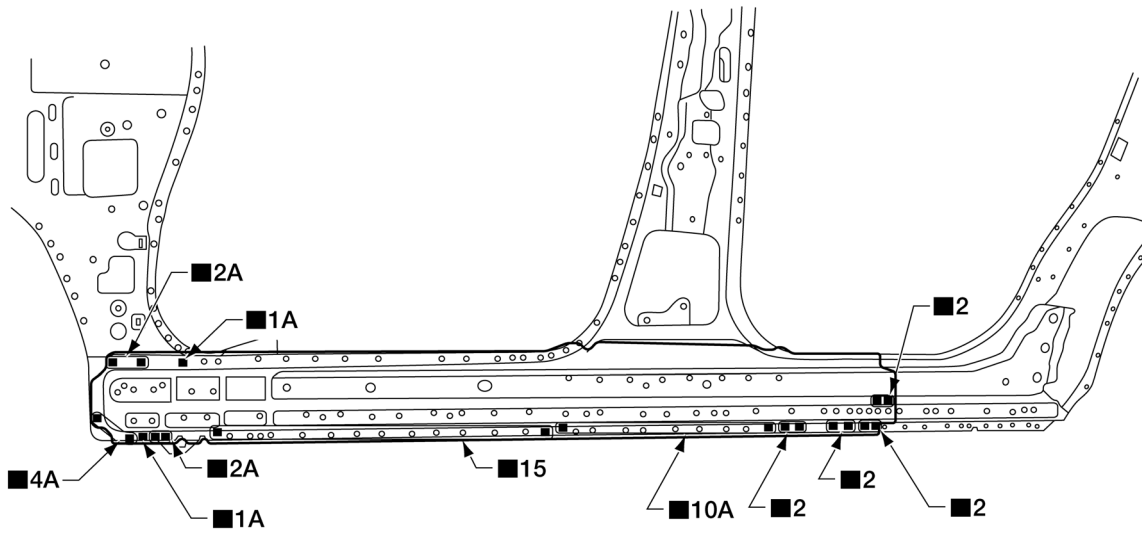

A
B
C
D
E
F
G
H
I
J
L
M
N
O
P

BRM

Replacement parts

- Outer sill reinforcement

ALKIA2453ZZ

REPLACEMENT OPERATIONS

< REMOVAL AND INSTALLATION >

Rear Fender

INFOID:00000008506525

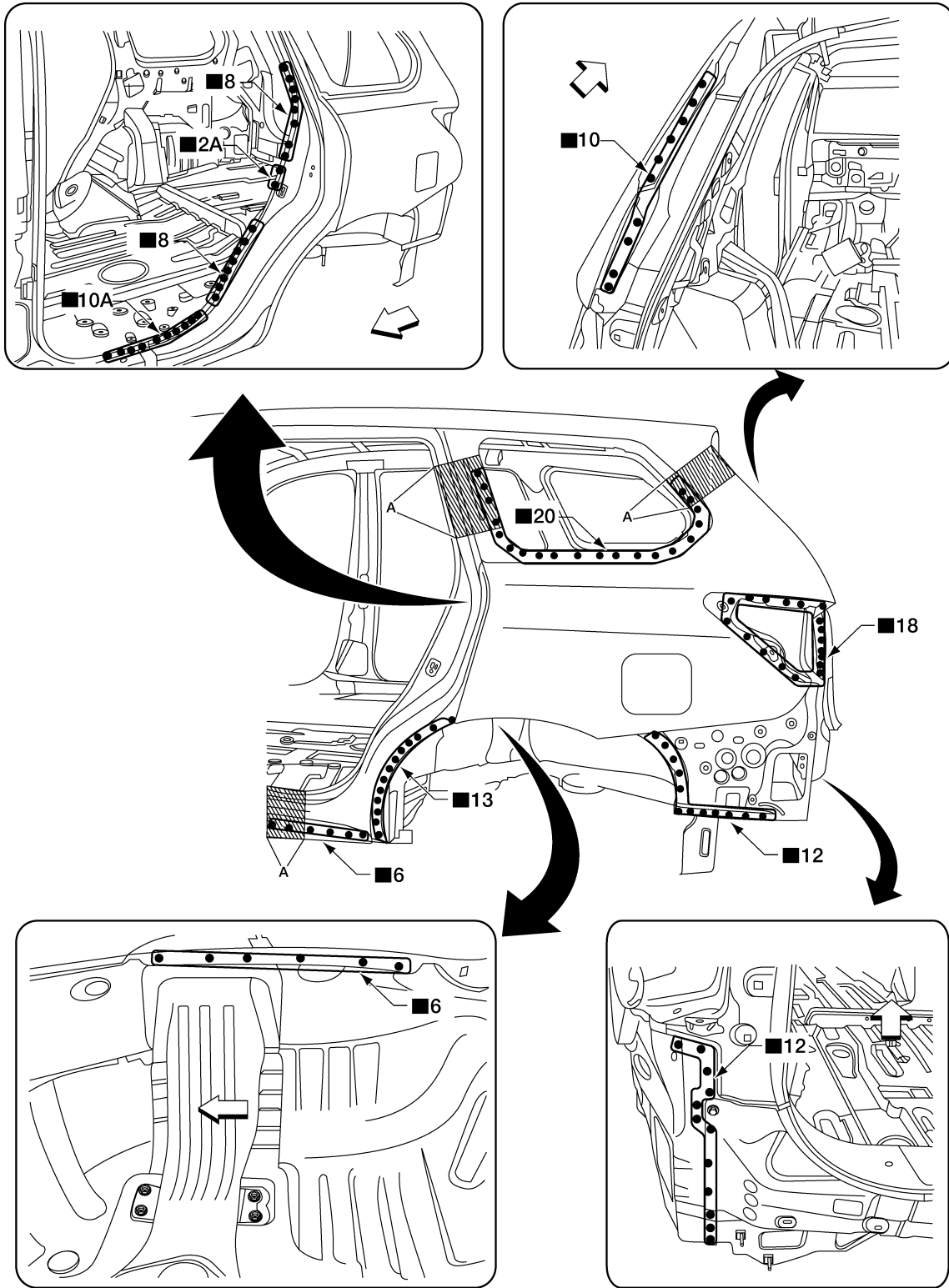

ALK1A2831Z2

Replacement parts

- Rear fender

A. Recommended sectioning location

↩ Front

REPLACEMENT OPERATIONS

< REMOVAL AND INSTALLATION >

Rear Body Side Inner Assembly

INFOID:000000008506526

- Work after rear body side outer has been removed.

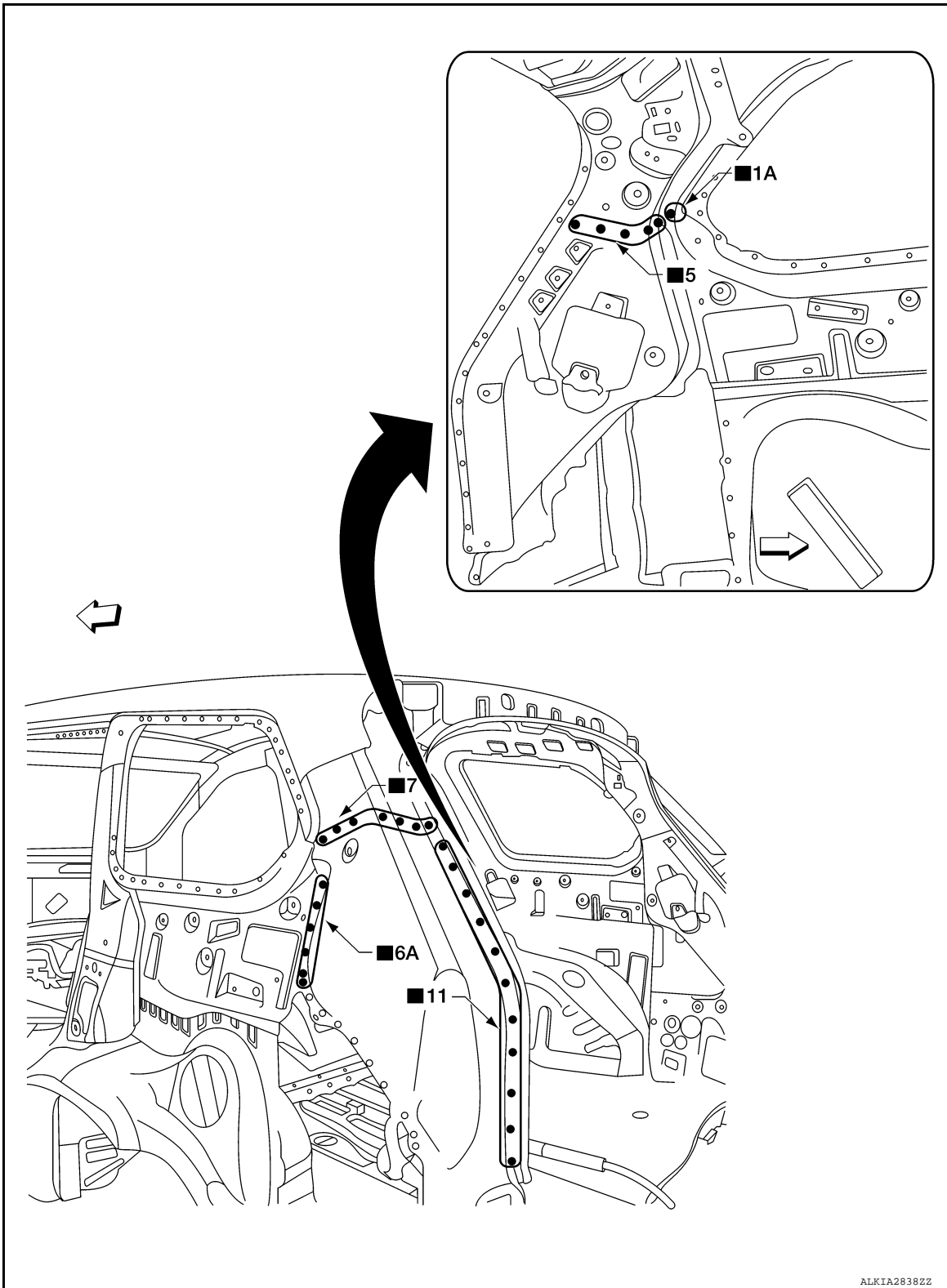

Replacement parts

- Rear pillar assembly

← Front

A
B
C
D
E
F
G
H
I
J
K
L
M
N
O
P

BRM

REPLACEMENT OPERATIONS

< REMOVAL AND INSTALLATION >

Rear Floor Rear

INFOID:000000008506527

- Work after rear panel assembly has been removed.

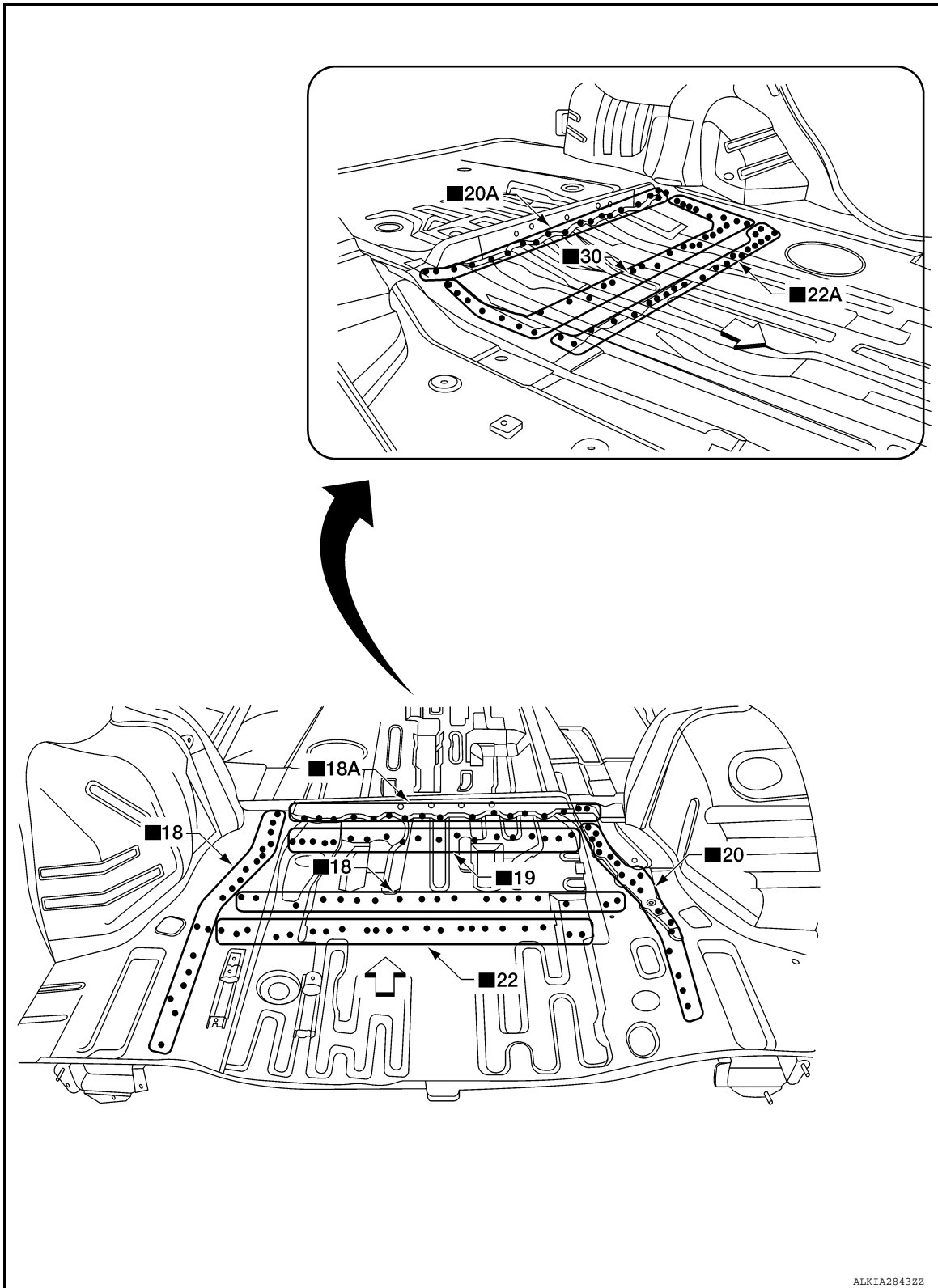

Replacement parts

- Rear floor rear

← Front

REPLACEMENT OPERATIONS

< REMOVAL AND INSTALLATION >

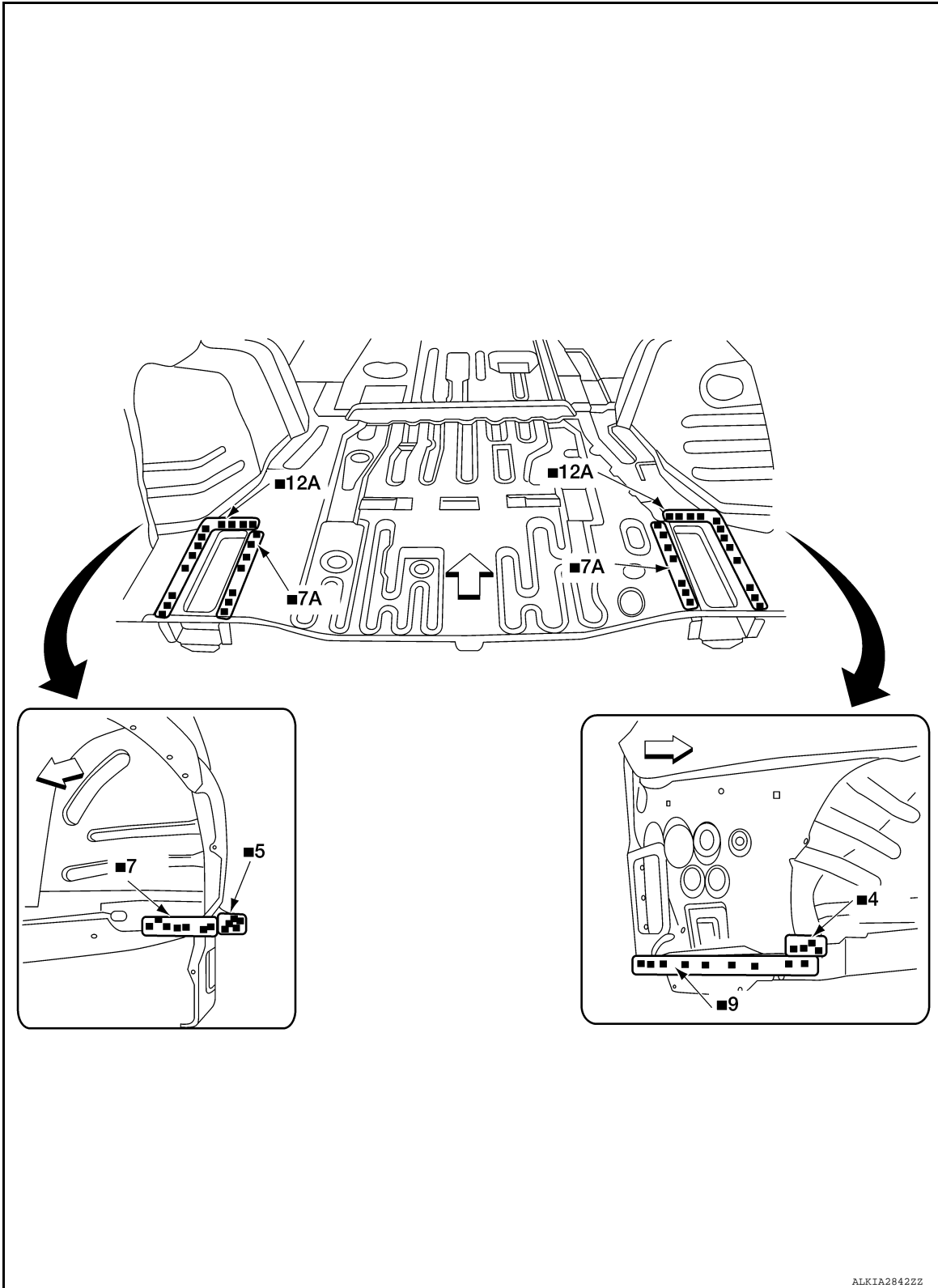

A
B
C
D
E
F
G
H
I
J
K
L
M
N
O
P

BRM

Replacement parts

- Rear side floor (RH, LH)
- Rear floor side assembly (RH, LH) ← Front

REPLACEMENT OPERATIONS

< REMOVAL AND INSTALLATION >

Rear Panel Assembly

INFOID:00000008506528

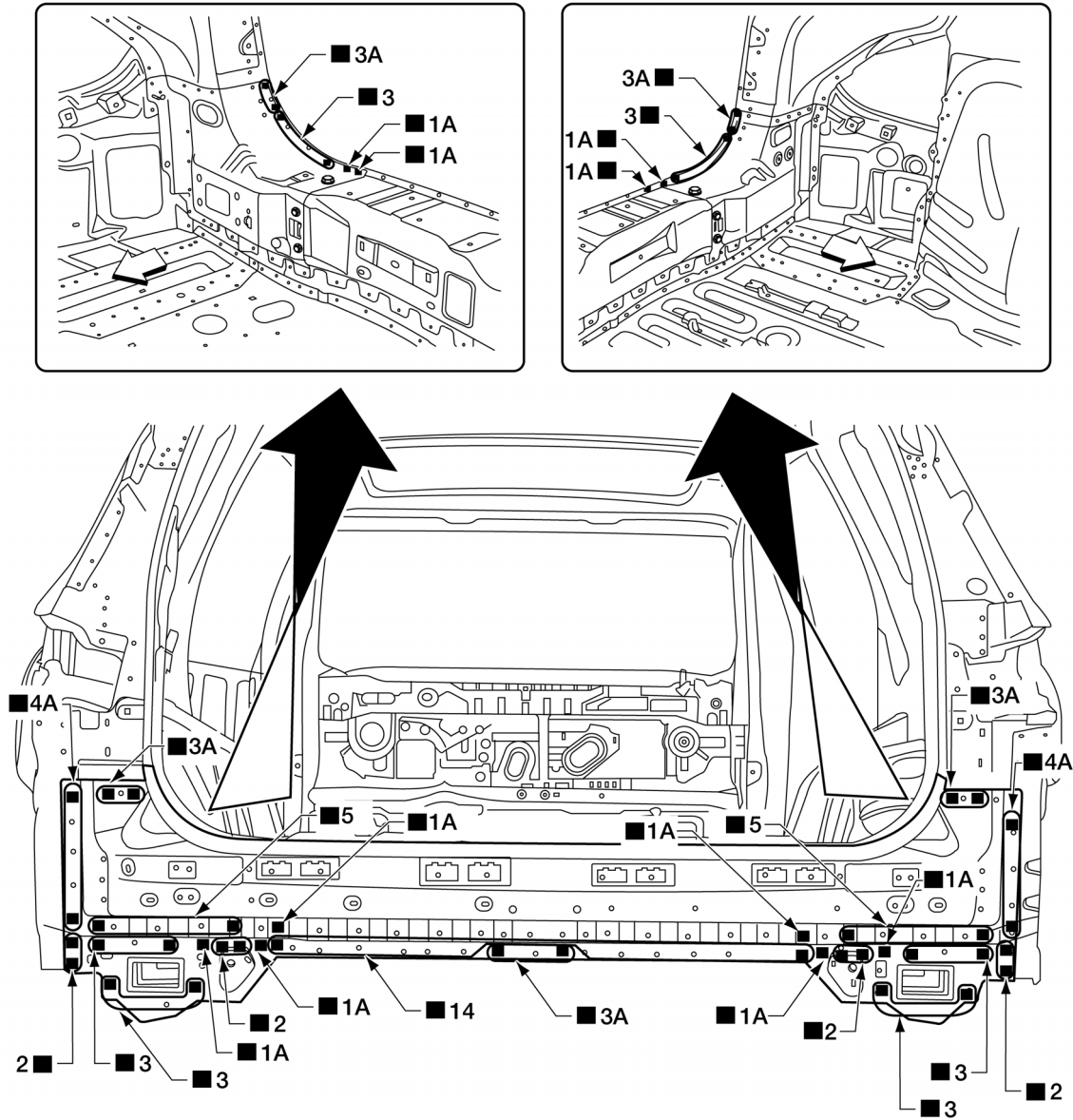

ALKIA2388ZZ

Replacement parts

- Rear panel assembly

← Front

REPLACEMENT OPERATIONS

< REMOVAL AND INSTALLATION >

Roof

INFOID:000000008506529

A
B
C
D
E
F
G
H
I
J
K
L
M
N
O
P

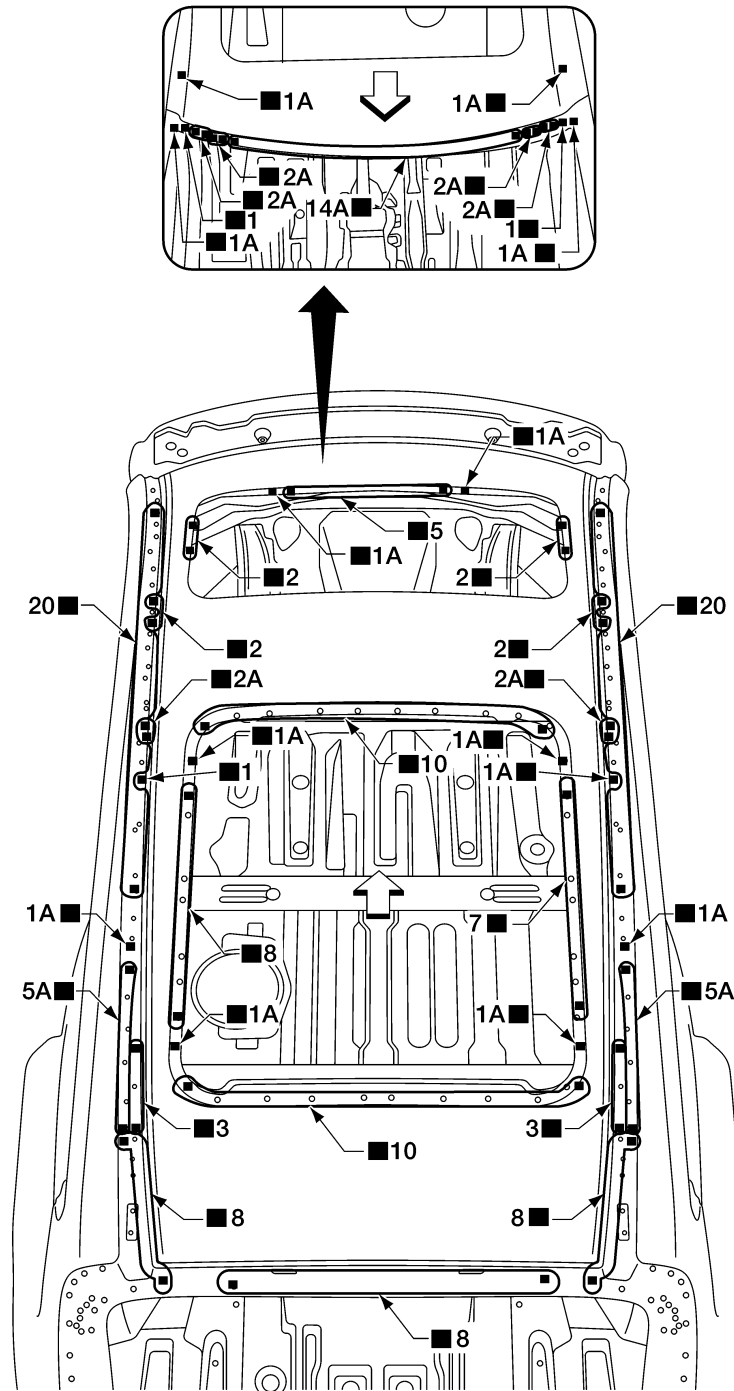

BRM

Replacement parts

- Roof panel, panoramic roof shown ← Front

ALKIA2847ZZ

REPLACEMENT OPERATIONS

< REMOVAL AND INSTALLATION >

Rear Side Member Extension

INFOID:00000008506530

- Work after rear panel assembly has been removed.

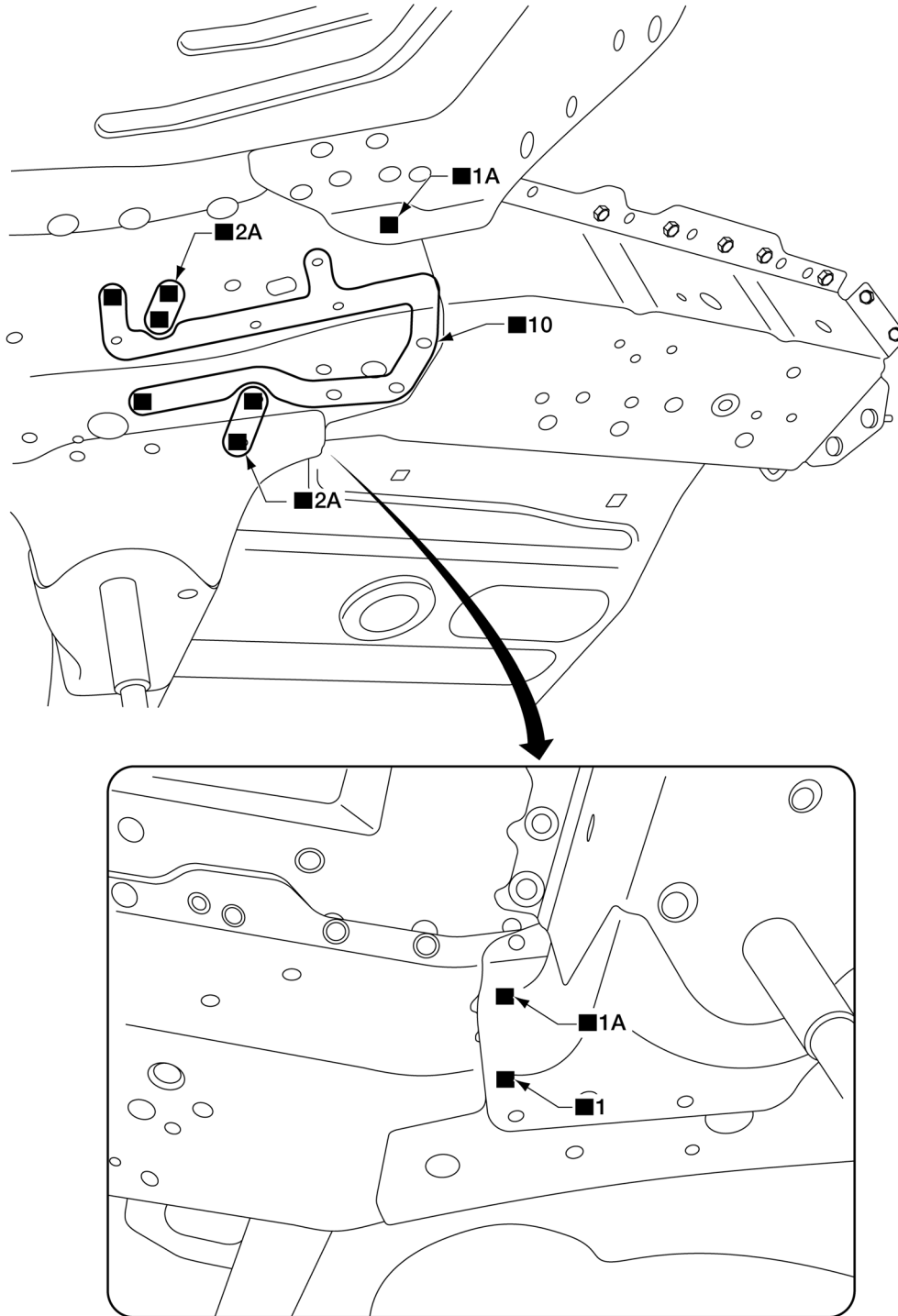

ALKIA24592Z

Replacement parts

- Rear side member extension

BODY ALIGNMENT

< SERVICE DATA AND SPECIFICATIONS (SDS)

SERVICE DATA AND SPECIFICATIONS (SDS)

BODY ALIGNMENT

Body Center Marks

INFOID:000000008506531

A mark is placed on each part of the body to indicate the vehicle center. When repairing the vehicle frame (members, pillars, etc.) damaged in an accident the most accurate and effective repair will be achieved by using these marks together with body alignment specifications.

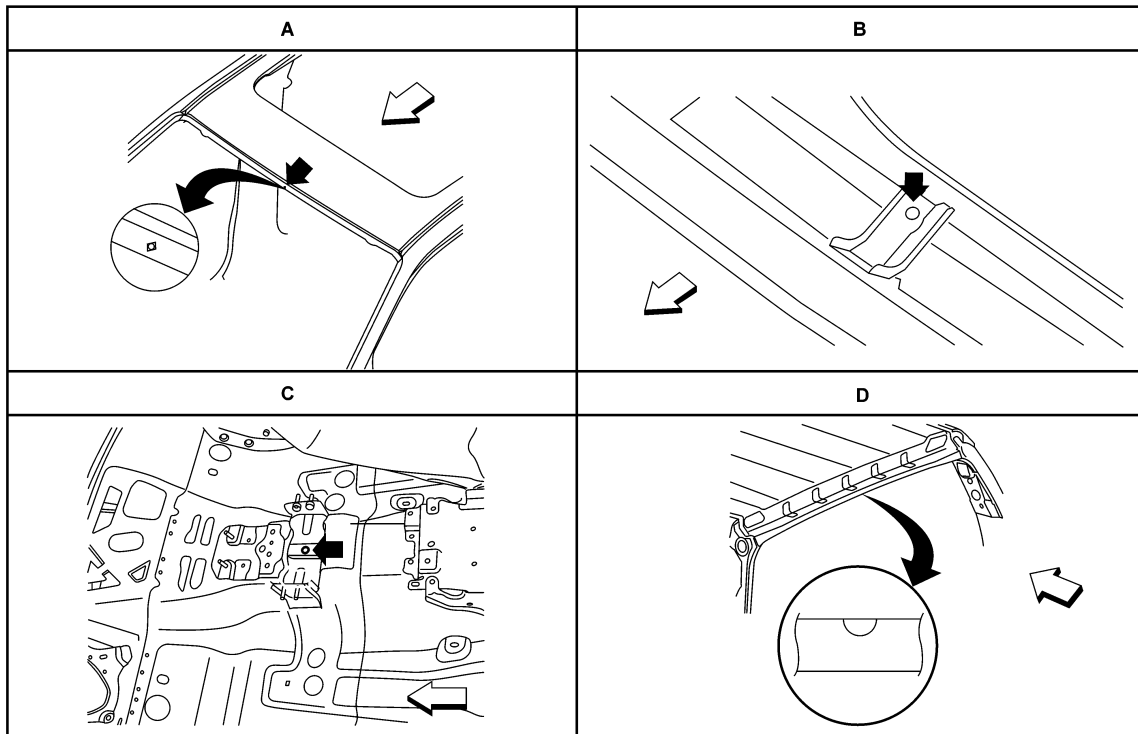
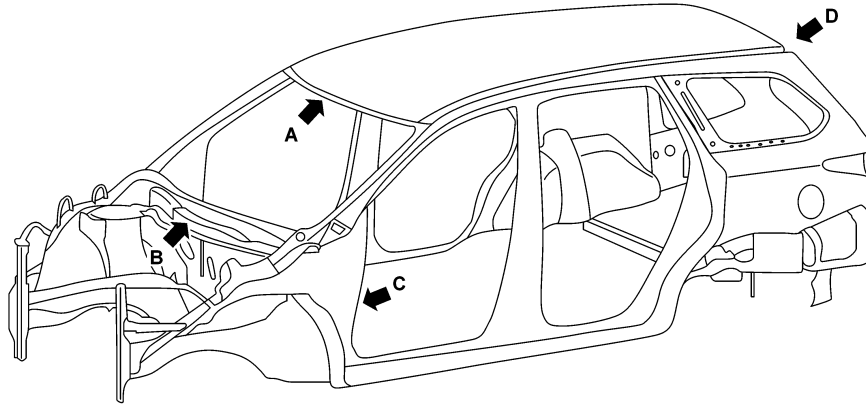

← Front

Points	Portion	Marks
A	Front roof	Embossment
B	Center cowl top	Hole
C	Front floor	Hole
D	Rear roof	Notch

A
B
C
D
E
F
G
H
I
J
BRM
L
M
N
O
P

BODY ALIGNMENT

< SERVICE DATA AND SPECIFICATIONS (SDS)

Description

INFOID:000000008506532

- All dimensions indicated in the figures are actual.
- When using a tracking gauge, adjust both pointers to equal length. Then check the pointers and gauge itself to make sure there is no free play.
- When a measuring tape is used, check to be sure there is no elongation, twisting or bending.
- Measurements should be taken at the center of the mounting holes.
- An asterisk (*) following the value at the measuring point indicates that the measuring point on the other side is symmetrically the same value.
- The coordinates of the measurement points are the distances measured from the standard line of "X", "Y" and "Z".
- "Z": Imaginary base line [200 mm (7.87 in) below datum line ("0Z" at design plan)]

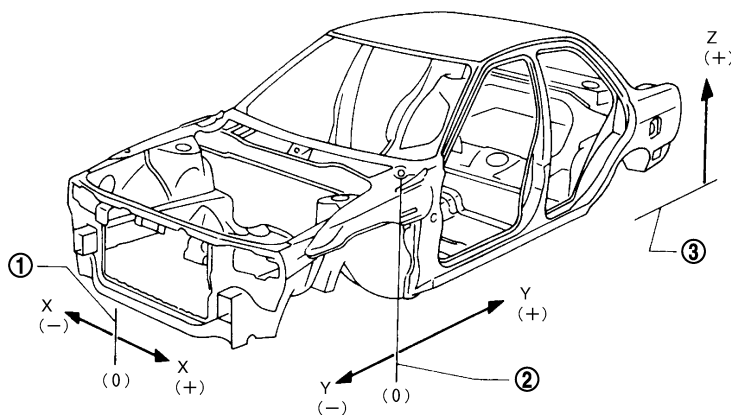

JSKIA0073GB

1. Vehicle center

2. Front axle center

3. Imaginary base line

Engine Compartment

INFOID:000000008506533

MEASUREMENT

Dimensions are symmetrically identical on both the RH and LH sides of the vehicle.

BODY ALIGNMENT

< SERVICE DATA AND SPECIFICATIONS (SDS)

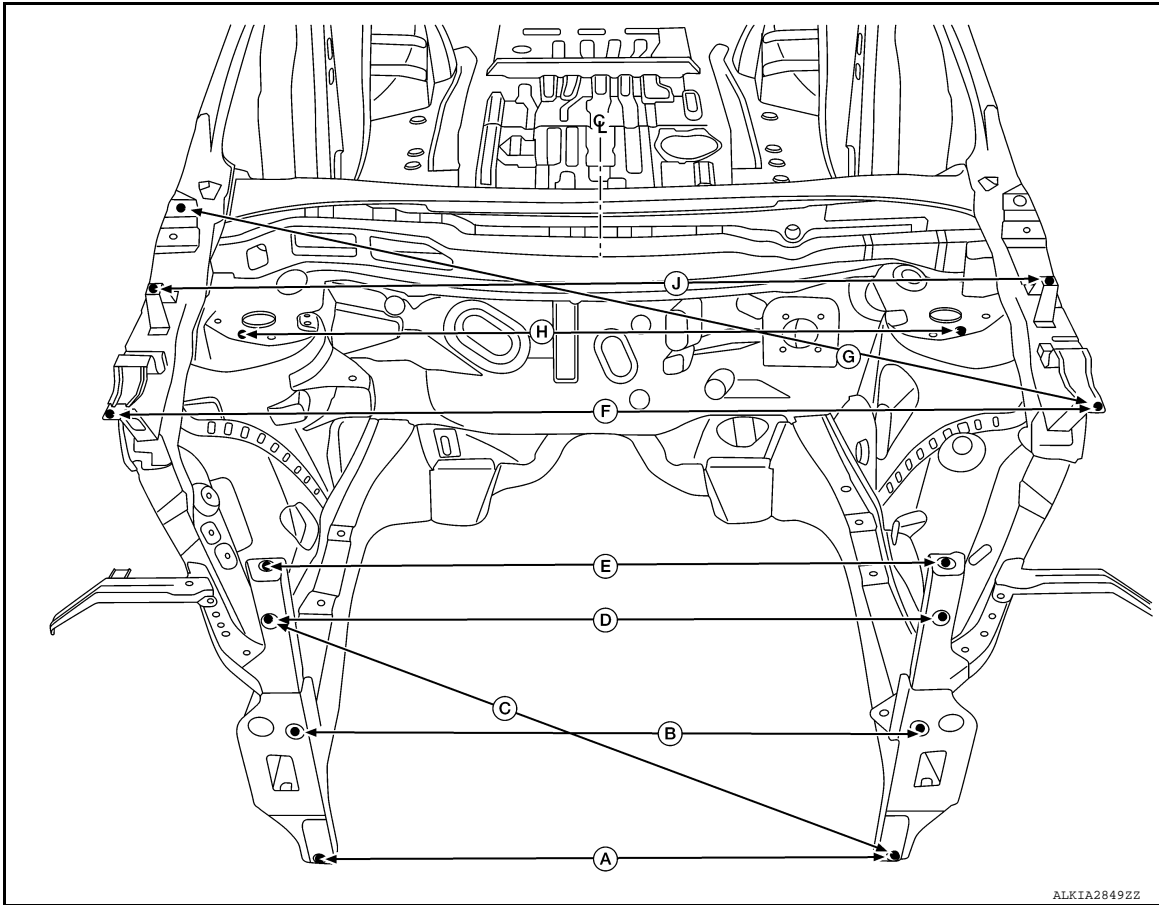

Unit: mm (in)

Position	Description	Measurement
A	Lower radiator support retaining hole 10 (0.4)	980 (38.6)
B	Upper inner bumper reinforcement retaining hole 10 (0.4)	973 (38.3)
C	Upper front radiator support retaining hole to lower radiator support retaining hole 10 (0.4)	1110 (43.7)
D	Upper front radiator support retaining hole 10 (0.4)	970 (38.2)
E	Top radiator support retaining hole 10 (0.4)	970 (38.2)
F	Front fender mounting bracket hole 8 (0.3)	1610 (63.4)
G	Rear hinge retaining hole 10 (0.4) to front fender bracket retaining hole 8 (0.3)	1590 (62.6)
H	Strut tower locator hole 12 (0.5)	1293 (50.9)
J	Center fender bracket retaining hole 8 (0.3)	1645 (64.8)

Underbody

INFOID:000000008506534

MEASUREMENT

The following shows a bottom view and a side view of the vehicle.

BODY ALIGNMENT

< SERVICE DATA AND SPECIFICATIONS (SDS)

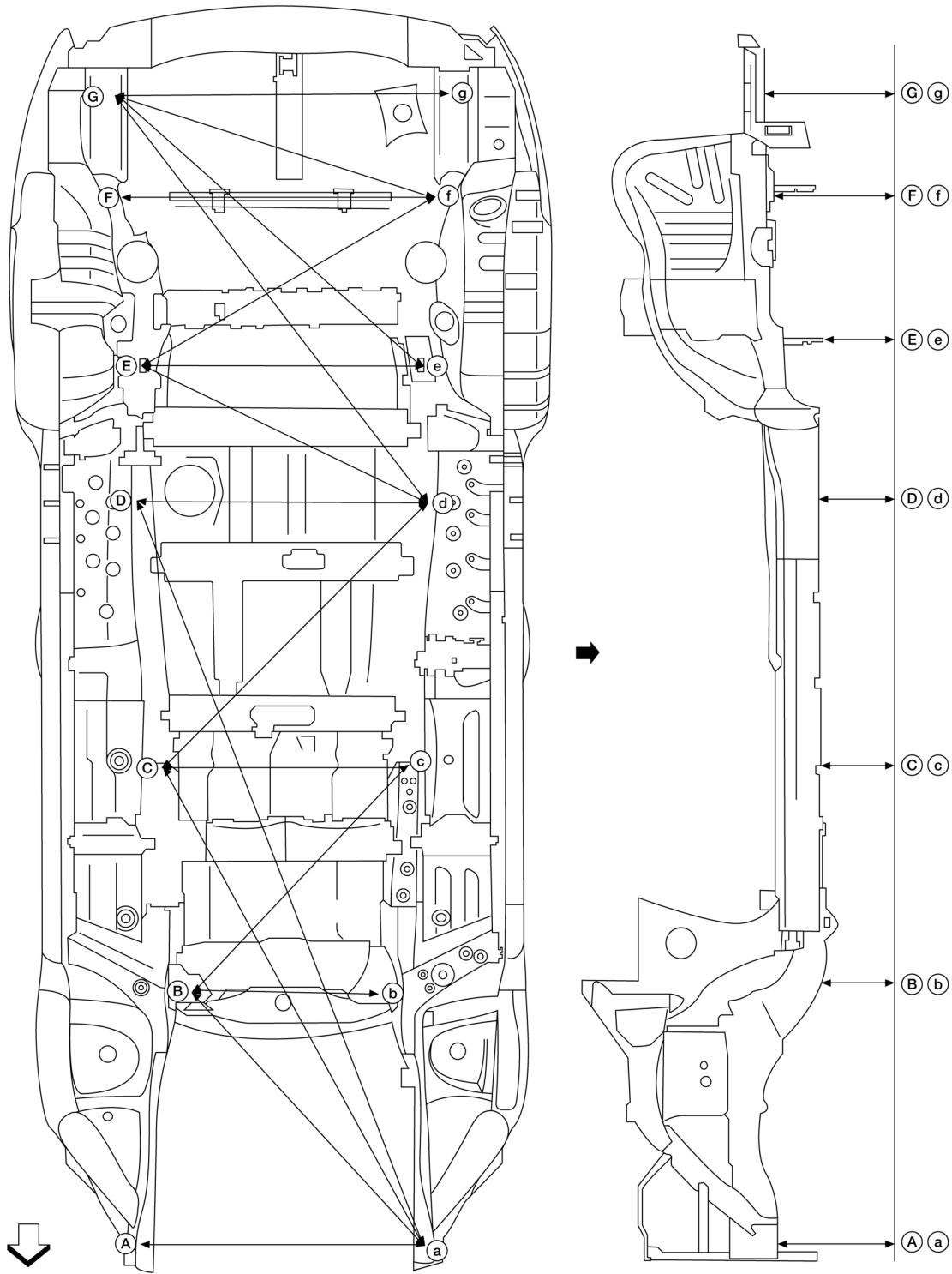

ALKIA2435ZZ

← Front

← Vehicle left side

Unit: mm (in)

Coordinates	Measurement	Coordinates	Measurement	Coordinates	Measurement
A-a	994.10 (39.14)	a-B*	1271.61 (50.00)	a-C*	2005.56 (78.96)
A-d*	2908.27 (114.50)	B-b	654.04 (25.75)	B-c*	1119.19 (44.06)
C-c	847.12 (33.35)	C-d*	1351.85 (53.22)	D-d	1027.90 (40.47)

BODY ALIGNMENT

< SERVICE DATA AND SPECIFICATIONS (SDS)

Coordinates	Measurement	Coordinates	Measurement	Coordinates	Measurement
d-E*	1142.51 (44.98)	D-g*	1845.85 (72.67)	E-e	1002.00 (39.45)
E-f*	1235.80 (48.65)	e-G*	1470.80 (57.91)	F-f	1130.19 (44.50)
F-f	1130.19 (44.50)	f-G*	1216.41 (47.89)	G-g	1187.54 (46.76)

Dimensions marked with "*" indicate symmetrically identical dimensions on both the RH and LH sides of the vehicle.

MEASUREMENT POINTS

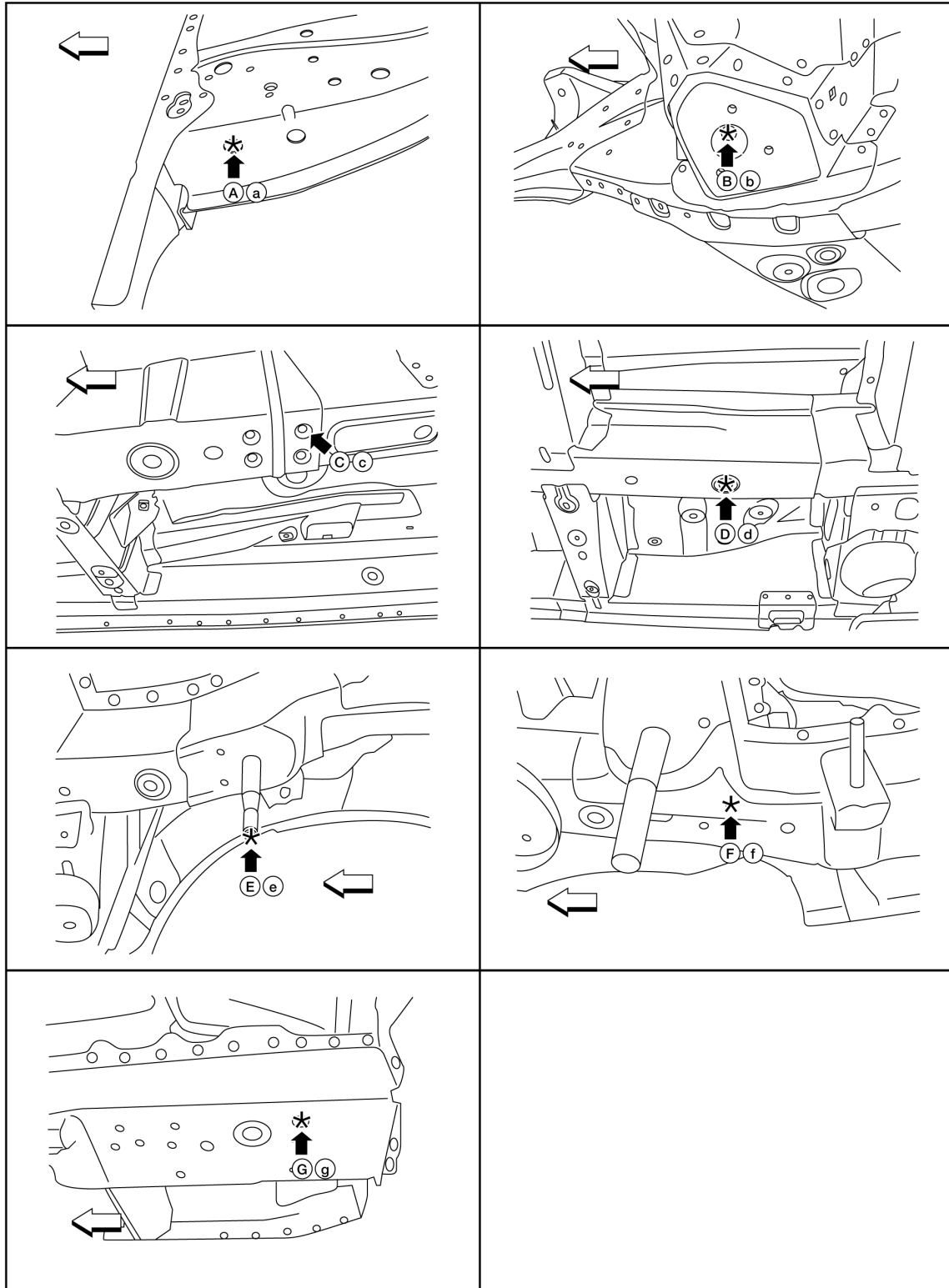

A
B
C
D
E
F
G
H
I
J
L
M
N
O
P

BRM

BODY ALIGNMENT

< SERVICE DATA AND SPECIFICATIONS (SDS)

↶ Front

Unit: mm (in)

Points	Coordinates			Remarks
	X	Y	Z	
A, a	±497.00 (±19.57)	±-555.50 (-12.87)	330.00 (12.99)	Hole 12.00 (0.47)
B, b	±327.00 (±12.87)	395.89 (15.59)	143.80 (5.66)	Hole 12.00 (0.47)
C, c	±437.06 (±17.21)	1212.19 (47.72)	171.93 (6.77)	Hole 9.00 (0.35)
D, d	±513.95 (±20.23)	1270.09 (50.00)	154.00 (6.06)	Hole 18.00×16.00 (0.71×0.63)
E, e	±501.0 (±)	2683.00 (105.63)	135.90 (5.35)	Center of stud end
F, f	±556.09 (±21.89)	3273.92 (128.89)	336.33 (13.24)	Hole 10.00 ×8.00 (0.36 x 0.31)
G, g	±593.79 (±23.38)	3643.54 (143.45)	340.93 (13.42)	Hole 11 (0.43)

Passenger Compartment

INFOID:000000008506535

MEASUREMENT

Dimensions are symmetrically identical on both the RH and LH side of the vehicle.

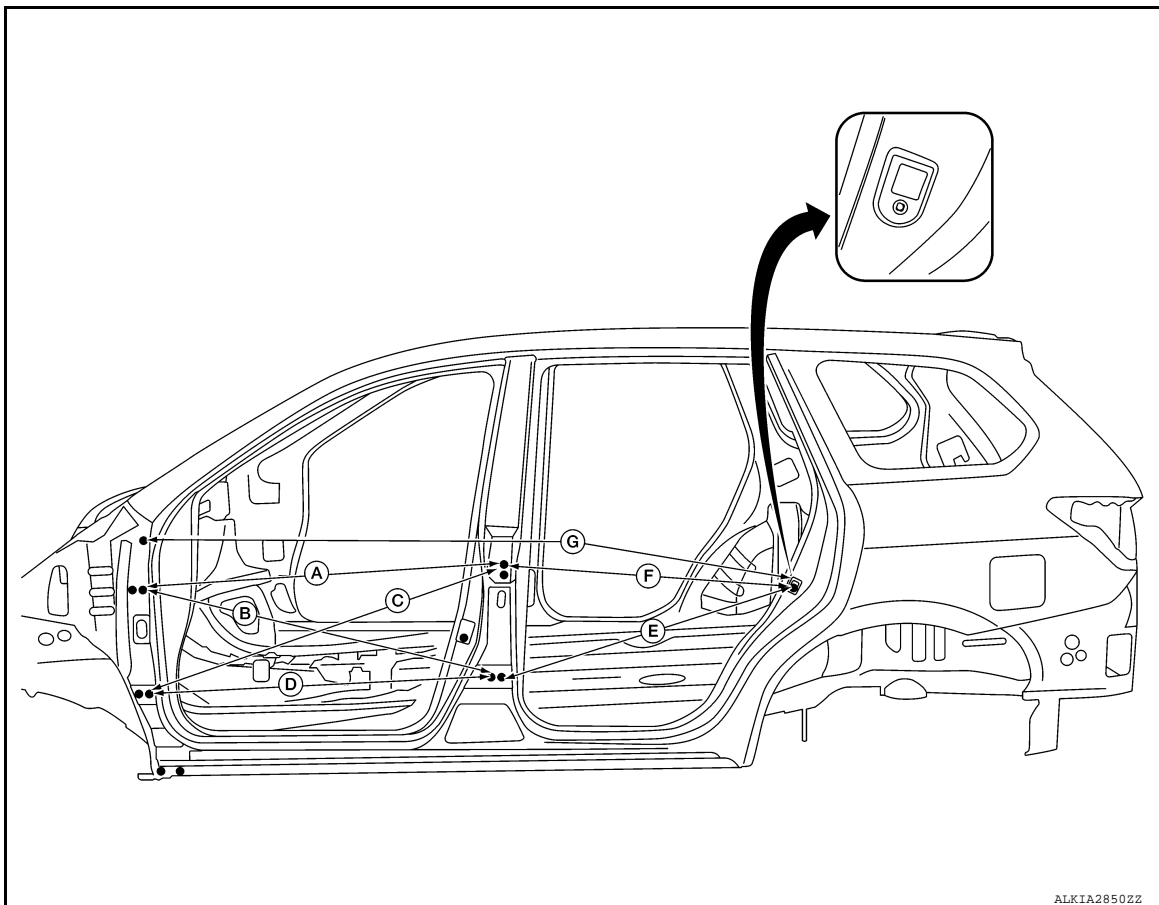

Unit: mm (in)

Position	Description	Measurement
A	Front door rear upper hinge bolt hole to rear door upper hinge top bolt hole	1175 (46.3)
B	Front door upper hinge rear bolt hole to rear door lower hinge front bolt	1160 (45.7)
C	Front door lower hinge rear bolt hole to rear door upper hinge top bolt hole	1236 (48.7)
D	Front door lower hinge rear bolt hole to rear door lower hinge front bolt hole	1120 (44.1)
E	Rear door lower hinge rear bolt hole to rear door switch screw hole	963 (37.9)

BODY ALIGNMENT

< SERVICE DATA AND SPECIFICATIONS (SDS)

Position	Description	Measurement
F	Rear door upper hinge lower bolt hole to rear door switch screw hole	910 (35.8)
G	Front fender hinge pillar retaining bolt hole to rear door switch screw hole	2050 (80.7)

Rear Body

INFOID:000000008506536

MEASUREMENT

Dimensions marked with "*" indicate symmetrically identical dimensions on both the RH and LH side of the vehicle.

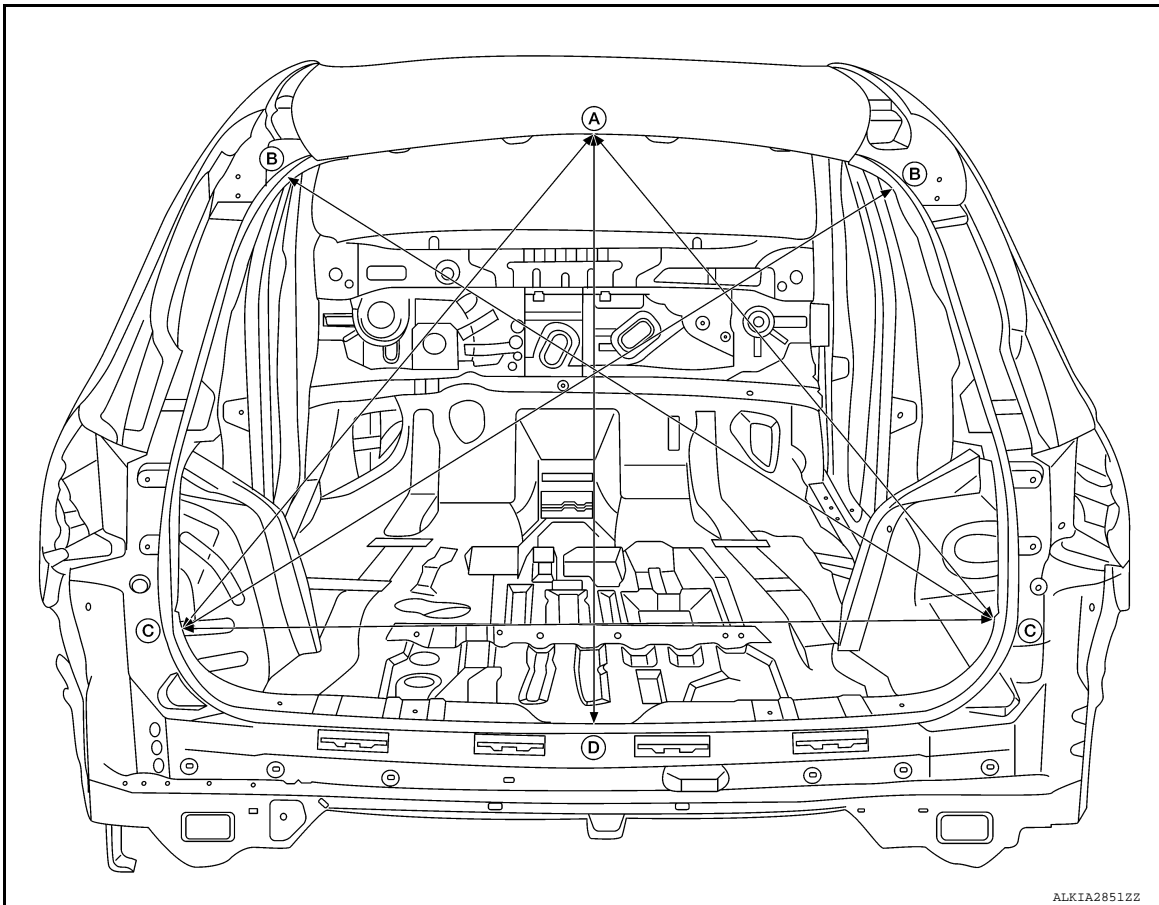

ALKIA2851ZZ

Unit: mm (in)

Point	Measurements	Point	Measurements
*A - C	1050 (41.3)	*B - C	1387 (54.6)
A - D	970 (38.2)	C - C	1315 (51.8)

MEASUREMENT POINTS

A
B
C
D
E
F
G
H
I
J
L
M
N
O
P

BRM

BODY ALIGNMENT

< SERVICE DATA AND SPECIFICATIONS (SDS)

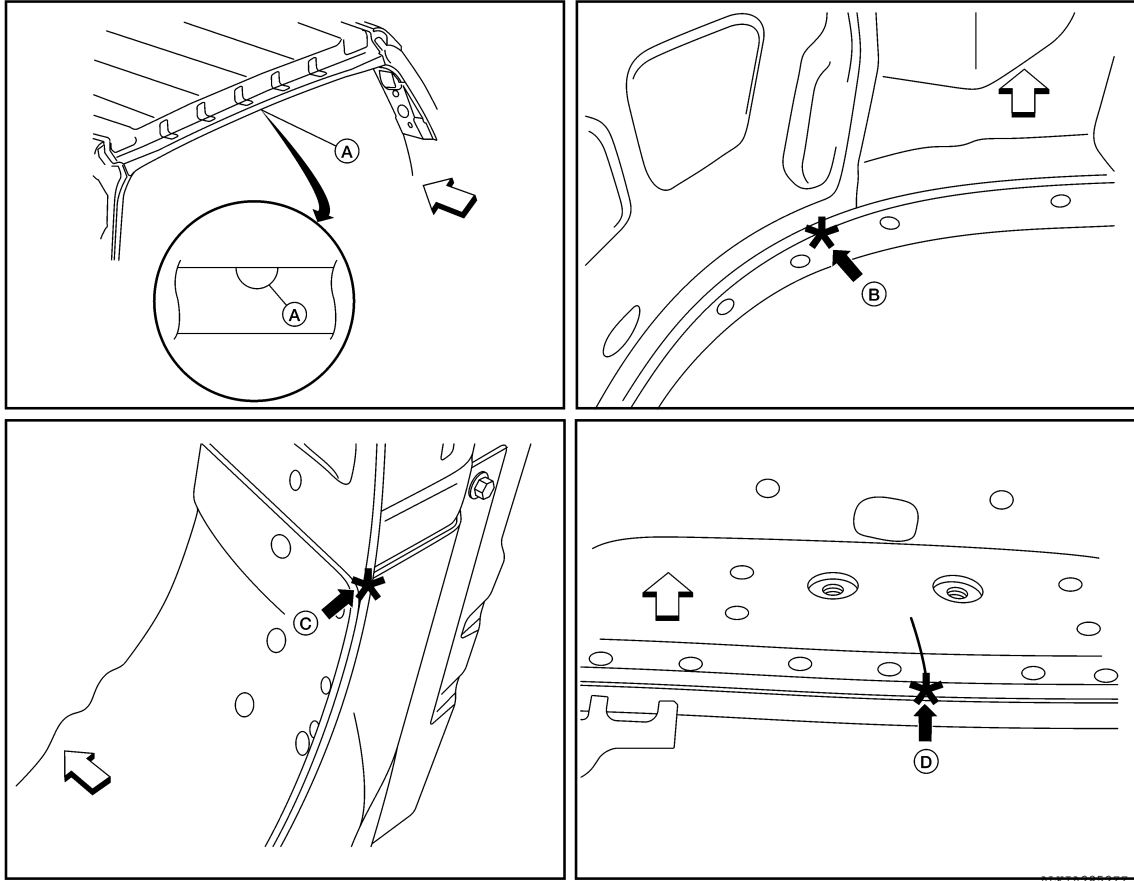

⇐ Front

Point	Description	Point	Description
A	Roof flange end of center positioning mark	B	Back pillar main joggle
C	Upper rear panel joggle	D	Edge of rear panel between back door striker installing holes