

SECTION **RAX**
REAR AXLE

A
B
C

RAX

CONTENTS

E

PRECAUTION	2	REAR DRIVE SHAFT	6	F
PRECAUTIONS	2	Inspection	6	
Precaution for Supplemental Restraint System (SRS) "AIR BAG" and "SEAT BELT PRE-TEN- SIONER"	2	REMOVAL AND INSTALLATION	7	G
Precautions for Drive Shaft	2	REAR WHEEL HUB	7	
PREPARATION	3	Exploded View	7	H
PREPARATION	3	Removal and Installation	7	
Special Service Tool	3	REAR DRIVE SHAFT	9	
Commercial Service Tool	3	Exploded View	9	I
SYMPTOM DIAGNOSIS	4	Removal and Installation	9	
NOISE, VIBRATION AND HARSHNESS (NVH) TROUBLESHOOTING	4	UNIT DISASSEMBLY AND ASSEMBLY ...	11	J
NVH Troubleshooting Chart	4	REAR DRIVE SHAFT	11	
PERIODIC MAINTENANCE	5	Disassembly and Assembly	11	K
WHEEL HUB	5	SERVICE DATA AND SPECIFICATIONS (SDS)	17	
On-vehicle Service	5	SERVICE DATA AND SPECIFICATIONS (SDS)	17	L
Inspection	5	Wheel Bearing	17	M
		Drive Shaft	17	

F
G
H
I
J
K
L
M
N
O
P

PRECAUTIONS

< PRECAUTION >

PRECAUTION

PRECAUTIONS

Precaution for Supplemental Restraint System (SRS) "AIR BAG" and "SEAT BELT PRE-TENSIONER"

INFOID:000000008507840

The Supplemental Restraint System such as "AIR BAG" and "SEAT BELT PRE-TENSIONER", used along with a front seat belt, helps to reduce the risk or severity of injury to the driver and front passenger for certain types of collision. Information necessary to service the system safely is included in the SR and SB section of this Service Manual.

WARNING:

- To avoid rendering the SRS inoperative, which could increase the risk of personal injury or death in the event of a collision which would result in air bag inflation, all maintenance must be performed by an authorized NISSAN/INFINITI dealer.
- Improper maintenance, including incorrect removal and installation of the SRS, can lead to personal injury caused by unintentional activation of the system. For removal of Spiral Cable and Air Bag Module, see the SR section.
- Do not use electrical test equipment on any circuit related to the SRS unless instructed to in this Service Manual. SRS wiring harnesses can be identified by yellow and/or orange harnesses or harness connectors.

PRECAUTIONS WHEN USING POWER TOOLS (AIR OR ELECTRIC) AND HAMMERS

WARNING:

- When working near the Airbag Diagnosis Sensor Unit or other Airbag System sensors with the Ignition ON or engine running, DO NOT use air or electric power tools or strike near the sensor(s) with a hammer. Heavy vibration could activate the sensor(s) and deploy the air bag(s), possibly causing serious injury.
- When using air or electric power tools or hammers, always switch the Ignition OFF, disconnect the battery and wait at least 3 minutes before performing any service.

Precautions for Drive Shaft

INFOID:000000008507842

Observe the following precautions when disassembling and assembling drive shaft:

- Joint sub-assembly does not disassemble because it is non-overhaul parts.
- Perform work in a location which is as dust-free as possible.
- Before disassembling and assembling, clean the outside of parts.
- Prevention of the entry of foreign objects must be taken into account during disassembly of the service location.
- Disassembled parts must be carefully reassembled in the correct order. If work is interrupted, a clean cover must be placed over parts.
- Paper shop cloths must be used. Fabric shop cloths must not be used because of the danger of lint adhering to parts.
- Disassembled parts (except for rubber parts) should be cleaned with kerosene which shall be removed by blowing with air or wiping with paper shop cloths.

PREPARATION

< PREPARATION >

PREPARATION

PREPARATION

Special Service Tool

INFOID:000000008507843

The actual shapes of Kent-Moore tools may differ from those of special service tools illustrated here.

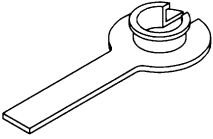
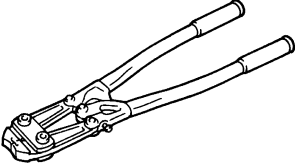
Tool number (Kent-Moore No.) Tool name	Description
KV38107900 (—) Differential side oil seal protector  NT147	Installing drive shaft
KV40107300 (—) Boot Band crimping tool  ZZA1229D	Installing boot bands

Commercial Service Tool

INFOID:000000008507844

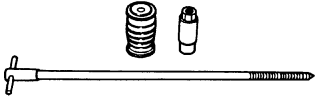
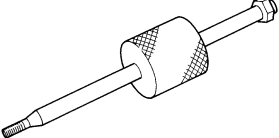
Tool name	Description
Power tool  PIIB1407E	Loosening nuts, screws and bolts
Drive shaft puller  JPDIG0152ZZ	Removing drive shaft joint sub assembly
Sliding hammer  ZZA0023D	Removing drive shaft

NOISE, VIBRATION AND HARSHNESS (NVH) TROUBLESHOOTING

< SYMPTOM DIAGNOSIS >

SYMPTOM DIAGNOSIS

NOISE, VIBRATION AND HARSHNESS (NVH) TROUBLESHOOTING

NVH Troubleshooting Chart

INFOID:000000008507845

Use chart below to find the cause of the symptom. If necessary, repair or replace these parts.

		Reference	Possible cause and SUSPECTED PARTS													
			Excessive joint angle	Joint sliding resistance	Imbalance	Improper installation, looseness	Parts interference	PROPELLER SHAFT	DIFFERENTIAL	REAR AXLE AND REAR SUSPENSION	REAR AXLE	TIRE	ROAD WHEEL	DRIVE SHAFT	BRAKE	
Symptom	DRIVE SHAFT	Noise	x	x				x	x	x	x	x	x		x	
		Shake	x		x			x		x	x	x	x		x	
	REAR AXLE	Noise				x	x	x	x	x		x	x	x	x	
		Shake				x	x	x		x		x	x	x	x	
		Vibration				x	x	x		x		x		x		
		Shimmy				x	x			x		x	x		x	
		Shudder				x				x		x	x		x	
		Poor quality ride or handling				x	x			x		x	x			

x: Applicable

WHEEL HUB

< PERIODIC MAINTENANCE >

PERIODIC MAINTENANCE

WHEEL HUB

On-vehicle Service

INFOID:000000008507846

Check axle and suspension parts for excessive play, wear or damage.

- Move the wheel as shown, to check for excessive play.

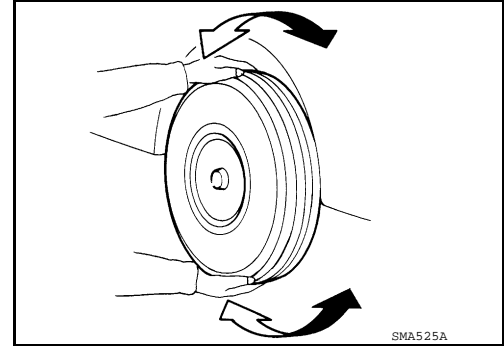

Inspection

INFOID:000000008507847

Rear Wheel Bearing

- Check wheel hub bearing axial end play.

Axial end play : Refer to [RAX-17, "Wheel Bearing"](#).

- Check that wheel hub bearings operate smoothly. Rotate the wheel hub and check for irregular conditions or unusual noise.
- Replace wheel hub if there is excessive axial end play or wheel bearing does not turn smoothly. Refer to [RAX-7, "Removal and Installation"](#).

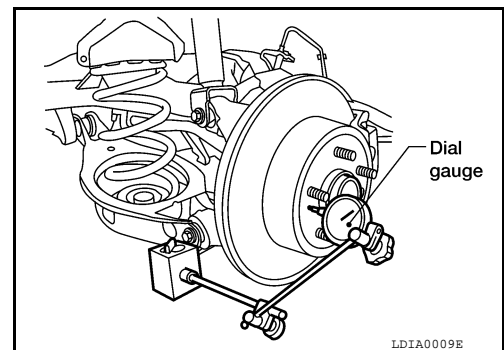

REAR DRIVE SHAFT

< PERIODIC MAINTENANCE >

REAR DRIVE SHAFT

Inspection

INFOID:000000008507848

Check the following items, and replace the parts as necessary.

- Check drive shaft mounting points and drive shaft joint for looseness and other damage.

CAUTION:

Replace entire drive shaft assembly when noise or vibration occurs from drive shaft.

- Check boot for cracks and other damage.

REAR WHEEL HUB

< REMOVAL AND INSTALLATION >

REMOVAL AND INSTALLATION

REAR WHEEL HUB

Exploded View

INFOID:000000008507849

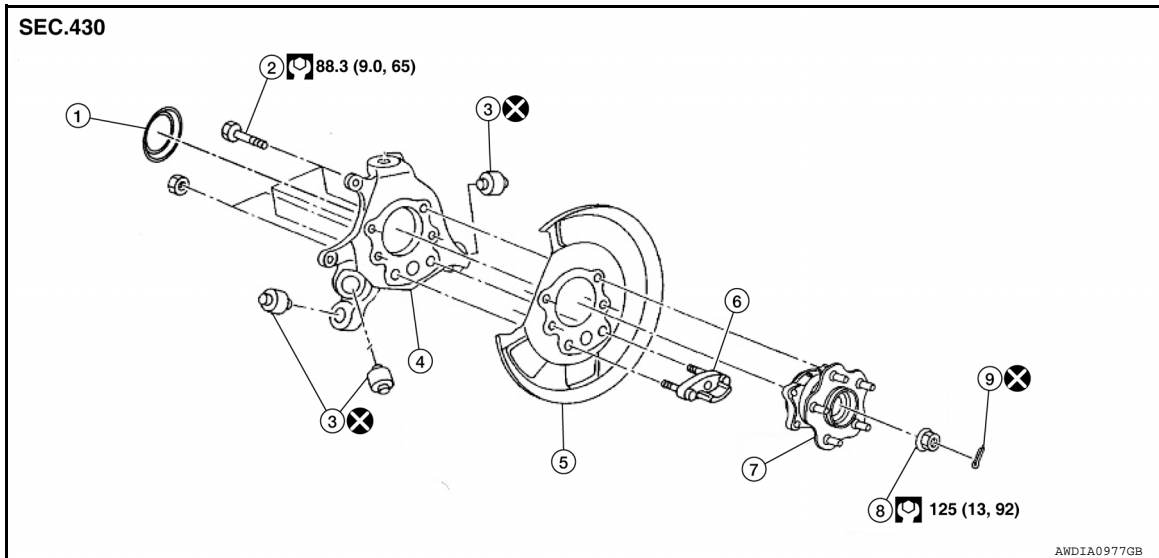

- | | | |
|--------------------------|-------------------------------|---------------------|
| 1. Hub cap | 2. Wheel hub and bearing bolt | 3. Bushings |
| 4. Rear knuckle | 5. Back plate | 6. Anchor block |
| 7. Wheel hub and bearing | 8. Wheel hub lock nut (4WD) | 9. Cotter pin (4WD) |

Removal and Installation

INFOID:000000008507850

REMOVAL

1. Remove the rear wheel and tire using power tool. Refer to [WT-57, "Adjustment"](#).
2. Remove the brake caliper torque member bolts, leaving the brake hose attached. Position the caliper aside with wire. Refer to [BR-36, "BRAKE CALIPER ASSEMBLY : Exploded View"](#).

CAUTION:

Do not depress the brake pedal while the caliper assembly is removed.

3. Put alignment marks on the disc brake rotor and on the wheel hub and bearing. Remove the disc brake rotor.

CAUTION:

Do not drop the disc brake rotor.

4. Remove the wheel sensor (1) from the knuckle. Refer to [BRC-117, "Exploded View - Rear Wheel Sensor"](#).

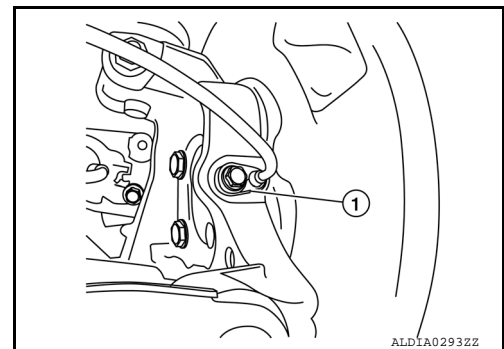

5. For 4WD vehicles, remove the cotter pin.
6. For 4WD vehicles, loosen, but do not remove, the wheel hub lock nut from the drive shaft using power tool.

REAR WHEEL HUB

< REMOVAL AND INSTALLATION >

7. For 4WD vehicles, use a piece of wood and a hammer, tap on the wheel hub lock nut to disengage the drive shaft from the wheel hub and bearing.

CAUTION:

- Do not place the drive shaft joint at an extreme angle. Be careful not to overextend the slide joint.
- Do not allow the drive shaft to hang without support.

NOTE:

Use a suitable puller if the drive shaft cannot be separated from the wheel hub and bearing.

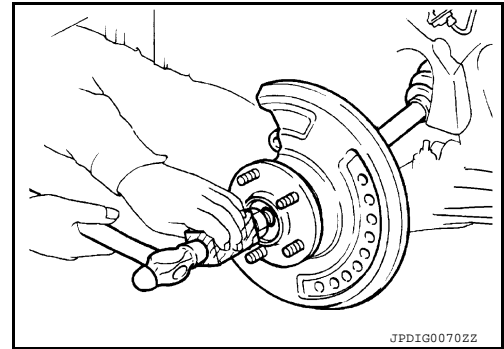

8. For 4WD vehicles, remove the wheel hub lock nut.
9. Remove the wheel hub and bearing bolts (A).

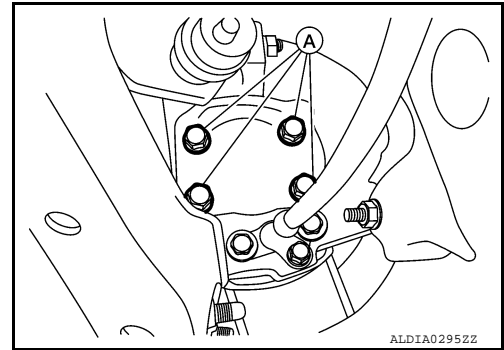

10. Remove the wheel hub and bearing.
11. Remove the hub cap.

INSTALLATION

Installation is in the reverse order of removal.

CAUTION:

- Do not reuse the bushings.
- Do not reuse the cotter pin.
- Do not use a power tool to tighten the wheel hub lock nut.
- Clean the mating surface of the wheel hub lock nut and the wheel hub and bearing.
- Clean the mating surface of the drive shaft and the wheel hub and bearing.
- Align the marks on the disc brake rotor and on the wheel hub and bearing.

REAR DRIVE SHAFT

< REMOVAL AND INSTALLATION >

REAR DRIVE SHAFT

Exploded View

INFOID:000000008507851

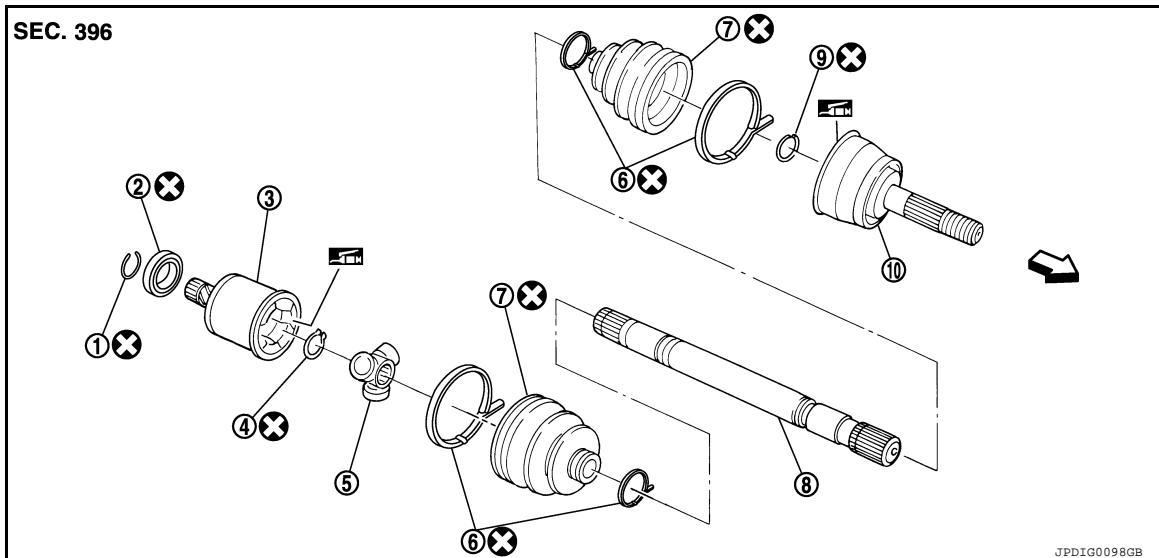

- | | | |
|------------------------|--------------------|------------------|
| 1. Circular clip | 2. Dust shield | 3. Housing |
| 4. Snap ring | 5. Spider assembly | 6. Boot band |
| 7. Boot | 8. Shaft | 9. Circular clip |
| 10. Joint sub-assembly | | |
- ← Wheel side

Removal and Installation

INFOID:000000008507852

REMOVAL

1. Remove the rear wheel and tire using power tool. Refer to [WT-57, "Adjustment"](#).
2. Remove the brake caliper torque member bolts, leaving the brake hose attached. Position the caliper aside with wire. Refer to [BR-36, "BRAKE CALIPER ASSEMBLY : Exploded View"](#).

CAUTION:

Do not depress the brake pedal while the caliper assembly is removed.

3. Put alignment marks on the disc brake rotor and on the wheel hub and bearing. Remove the disc brake rotor.

CAUTION:

Do not drop the disc brake rotor.

4. Remove the wheel sensor (1) from the knuckle. Refer to [BRC-117, "Exploded View - Rear Wheel Sensor"](#).

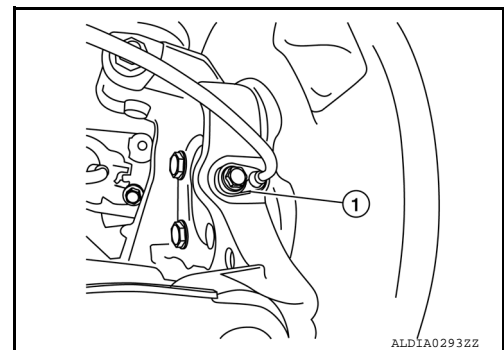

5. Remove the cotter pin.
6. Loosen, but do not remove, the wheel hub lock nut from the drive shaft using power tool.

A
B
C
RAX
E
F
G
H
I
J
K
L
M
N
O
P

REAR DRIVE SHAFT

< REMOVAL AND INSTALLATION >

7. Using a piece of wood and a hammer, tap on the wheel hub lock nut to disengage the drive shaft from the wheel hub and bearing.

CAUTION:

- Do not place the drive shaft joint at an extreme angle. Be careful not to overextend the slide joint.
- Do not allow the drive shaft to hang without support.

NOTE:

Use a suitable puller if the drive shaft cannot be separated from the wheel hub and bearing.

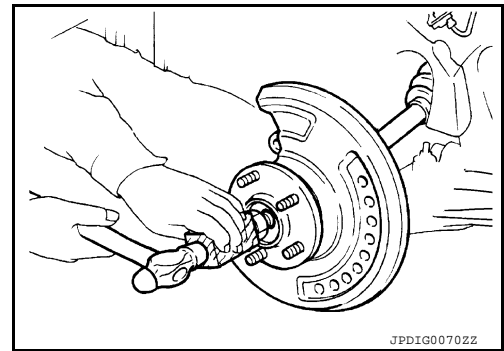

8. Remove the wheel hub lock nut.
9. Remove wheel hub and bearing. Refer to [RAX-7, "Exploded View"](#).
10. Remove the hub cap.
11. Remove the rear drive shaft from the final drive assembly.
12. Remove the side oil seal. Refer to [DLN-117, "Removal and Installation"](#).

INSPECTION AFTER REMOVAL

- Move joint up/down, left/right and in axial direction. Check for any rough movement or significant looseness.
- Check boots for cracks, grease leakage or other damage.
- If damaged, disassemble drive shaft to verify damage and repair or replace as necessary.

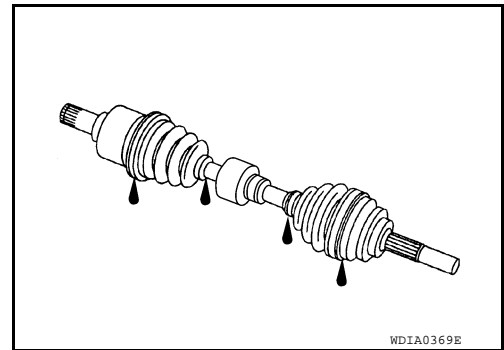

INSTALLATION

Installation is in the reverse order of removal.

CAUTION:

- Do not reuse the side oil seal.
- Do not reuse the cotter pin.
- Do not use a power tool to tighten the wheel hub lock nut.
- Install the side oil seal. Refer to [DLN-117, "Removal and Installation"](#).
- In order to prevent damage to the side oil seal, place Tool (A) onto oil seal, as shown, before inserting the drive shaft.

Tool number : KV38107900 (—)

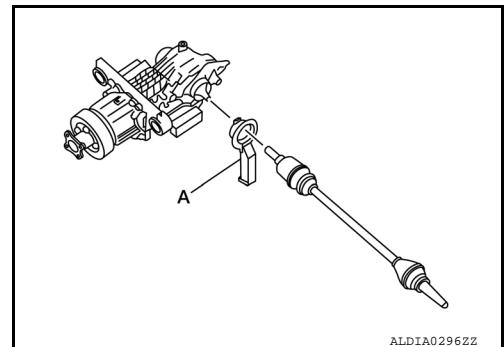

- Slide rear drive shaft into the slide joint and tap with a hammer to install securely.
- Clean the mating surface of the wheel hub lock nut and the wheel hub and bearing.
- Clean the mating surface of the drive shaft and the wheel hub and bearing.
- Align the marks on the disc brake rotor and on the wheel hub and bearing.

REAR DRIVE SHAFT

< UNIT DISASSEMBLY AND ASSEMBLY >

UNIT DISASSEMBLY AND ASSEMBLY

REAR DRIVE SHAFT

Disassembly and Assembly

INFOID:000000008507853

DISASSEMBLY

Wheel Side

1. Mount the drive shaft in a vise.

CAUTION:

When mounting shaft in a vise, always use aluminum or copper plates between vise and drive shaft.

2. Remove and discard boot bands and slide boot back.
3. Screw the drive shaft puller (A) 30 mm (1.18 in) or more into the thread of joint sub-assembly. Pull joint sub-assembly (B) from shaft.

CAUTION:

- Align sliding hammer or suitable tool and drive shaft, then remove joint sub-assembly by pulling directly.
- If joint sub-assembly cannot be removed after five or more unsuccessful attempts, replace shaft and joint sub-assembly as a set.

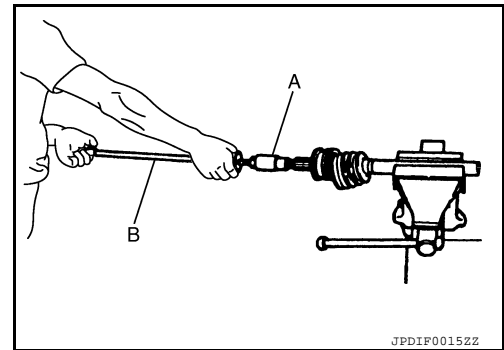

4. Remove and discard circular clip from shaft.

CAUTION:

Do not reuse circular clip.

5. Remove boot from shaft.
6. While rotating ball cage, clean old grease from joint sub-assembly.

Final Drive Side

1. Mount drive shaft in a vise.

CAUTION:

When mounting front drive shaft in a vise, always use copper or aluminum plates between vise and shaft.

2. Remove and discard boot bands and slide boot back.
3. Put matching marks on slide joint housing and shaft before separating joint assembly.

CAUTION:

Use paint or an equivalent for matching marks. Do not scratch the surface.

4. Put matching marks (A) on the spider assembly and shaft.

CAUTION:

Use paint or an equivalent for matching marks. Do not scratch the surface.

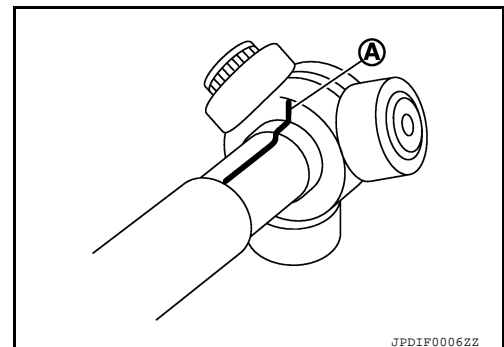

REAR DRIVE SHAFT

< UNIT DISASSEMBLY AND ASSEMBLY >

5. Remove and discard snap ring (1) using a suitable tool.

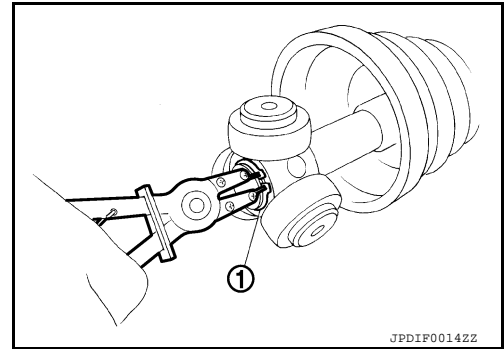

6. Remove spider assembly from shaft.
7. Disassemble the shaft as follows:
 1. Remove boot from shaft.
 2. Remove and discard circular clip from housing.
 3. Remove and discard dust shield.
 4. Clean all old grease off of the slide joint assembly.

INSPECTION AFTER DISASSEMBLY

Shaft

- Replace shaft if there is any bending, cracking, or other damage.

Joint Sub-assembly

- Make sure there is no rough rotation or unusual axial looseness.
- Make sure there is no foreign material inside joint sub-assembly.
- Check joint sub-assembly for compression scars, cracks or fractures.

CAUTION:

If there are any irregular conditions of joint sub-assembly components, replace the entire joint sub-assembly.

Sliding Joint Housing and Spider Assembly

- If roller surface of spider assembly has scratches or wear, replace housing and spider assembly.

NOTE:

Housing and spider assembly are components which are used as a set.

ASSEMBLY

Wheel Side

1. Insert the amount of grease (Genuine NISSAN Grease or equivalent) into joint sub-assembly until grease begins to ooze from ball groove and serration hole. After inserting grease, use a shop cloth to wipe off old grease that has oozed out.

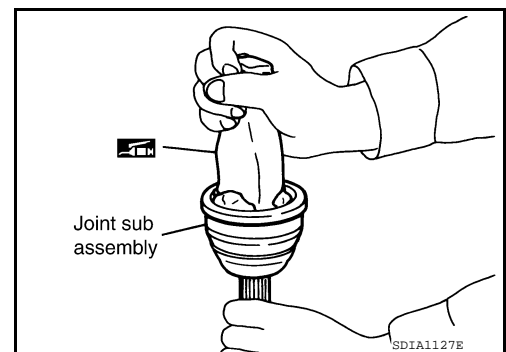

REAR DRIVE SHAFT

< UNIT DISASSEMBLY AND ASSEMBLY >

2. Cover serrated part of shaft with tape, then install a new boot and boot band onto shaft.

CAUTION:

- Do not reuse boot and boot bands.

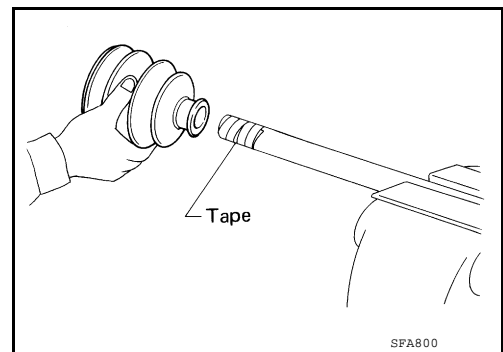

3. Remove protective tape wrapped around the serration part on shaft.
4. Attach new circlip to shaft. The circlip must fit securely into shaft groove. Attach nut to joint sub-assembly. Use a suitable tool to press-fit.

CAUTION:

- Do not reuse circular clip.

5. Install joint sub-assembly to shaft using plastic hammer.

CAUTION:

- Confirm that joint sub-assembly is correctly engaged while rotating drive shaft.

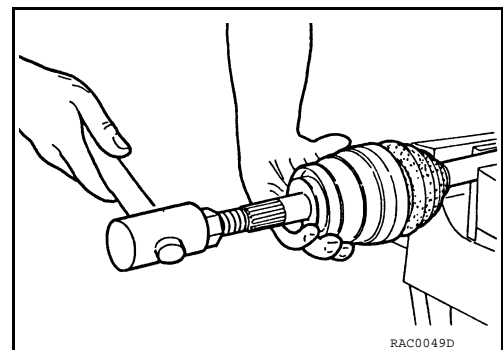

6. Insert the specified amount of grease (Genuine NISSAN Grease or equivalent) listed below into housing from large diameter side of boot.

Grease quantity : Refer to [RAX-17, "Drive Shaft"](#).

7. Install the boot securely into grooves (indicated by "*" marks) shown.

CAUTION:

- If there is grease on the boot mounting surface (indicated by "*" mark) of the shaft or joint sub-assembly, boot may come off. Remove all grease from the boot mounting surface.

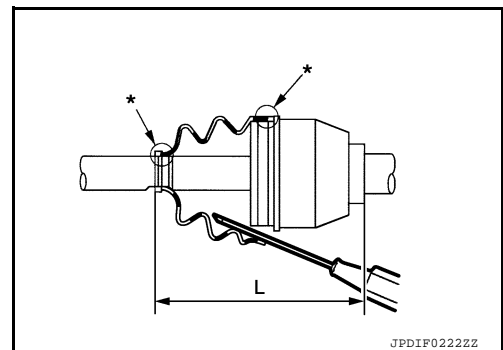

- To prevent the deformation of the boot, adjust the boot installation length (L) to the specified value indicated below. Insert a suitable tool into the large end of boot. Bleed air from boot to prevent boot deformation.

Boot installation length (L) : Refer to [RAX-17, "Drive Shaft"](#).

CAUTION:

- Boot may be damaged if the installation length exceeds or is less than standard value.
- Be careful that suitable tool does not contact inside surface of boot.

REAR DRIVE SHAFT

< UNIT DISASSEMBLY AND ASSEMBLY >

8. Install new large and small boot bands securely to specification and using Tool.

Tool number : KV40107300 (—)

CAUTION:

Do not reuse boot bands.

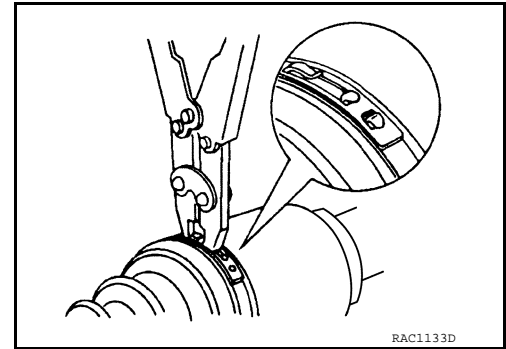

- Secure boot band so that dimension (M) meets specification as shown.

Dimension (M) : Refer to **RAX-17, "Drive Shaft"**.

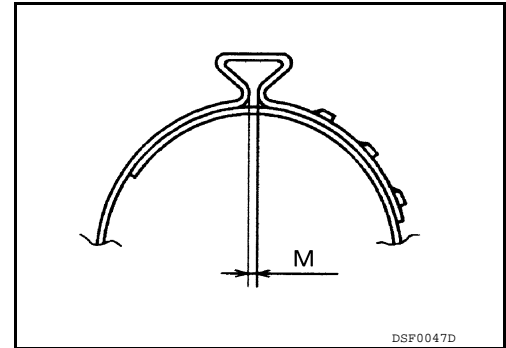

9. After installing joint sub-assembly and shaft, make sure that they are in the correct position when rotating boot. If boot position is not correct, remove old boot bands then reposition the boot and secure with new boot bands.

CAUTION:

Do not reuse boot bands.

Final Drive Side

1. Install new boot and new small boot band to shaft.

CAUTION:

- Cover drive shaft serration with tape to prevent damage to boot during installation.
- Do not reuse boot or boot band.

2. Remove protective tape wrapped around serrated part of shaft.

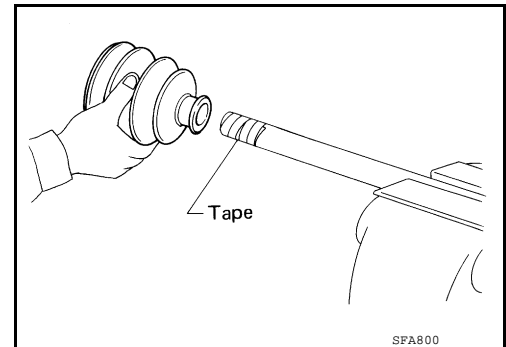

3. Install the spider assembly (1).

- Align it with the matching marks (A) on the shaft (2) made during disassembly and direct the serration mounting surface (B) onto the shaft.

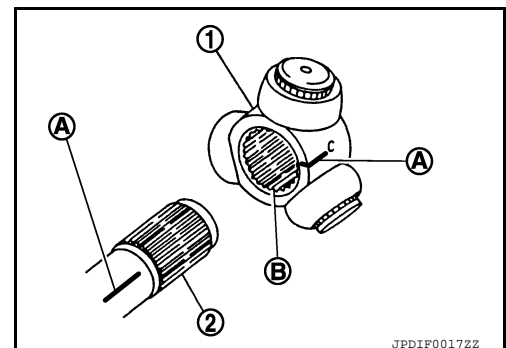

REAR DRIVE SHAFT

< UNIT DISASSEMBLY AND ASSEMBLY >

4. Install new snap ring (1) using suitable tool onto shaft.

CAUTION:

Do not reuse snap ring.

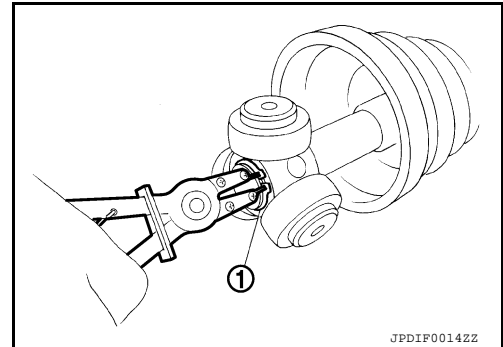

5. Pack housing with the specified amount of new grease (Genuine NISSAN Grease or equivalent).

Grease amount : Refer to [RAX-17, "Drive Shaft"](#).

6. Align matching marks made during disassembly and install the housing onto spider assembly.
7. After installation, pull shaft to check engagement between slide joint assembly and circular clip.
8. Install boot securely into grooves (indicated by "*" marks) as shown.

CAUTION:

If there is grease on boot mounting surfaces (indicated by "*" marks) on shaft or housing, boot may come off. Clean all grease from the boot mounting surfaces (*).

9. Make sure boot installation length (L) is the length specified below. Insert a suitable tool into large end of boot. Bleed air from boot to prevent boot deformation.

Boot installation length (L) : Refer to [RAX-17, "Drive Shaft"](#).

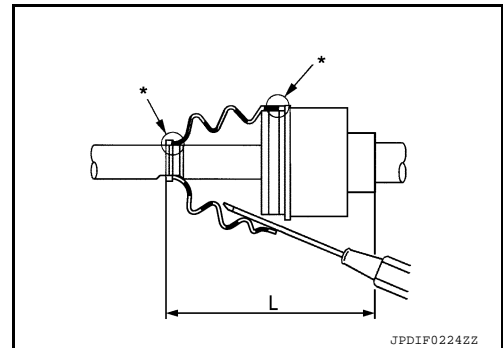

CAUTION:

- Boot may break if boot installation length exceeds or is less than the standard value.
- Be careful that suitable tool does not contact inside surface of the boot.

10. Install new large and small boot bands securely using Tool.

Tool number : KV40107300 (—)

CAUTION:

Do not reuse boot band.

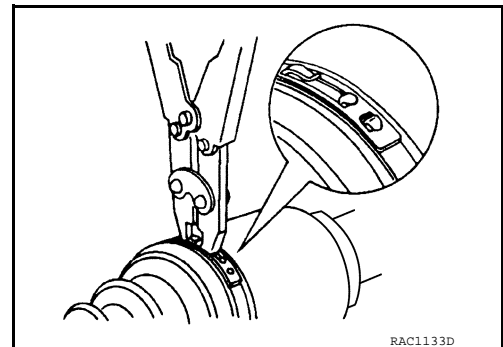

- Secure boot band so the dimension (M) meets specifications as shown.

Dimension (M) : Refer to [RAX-17, "Drive Shaft"](#).

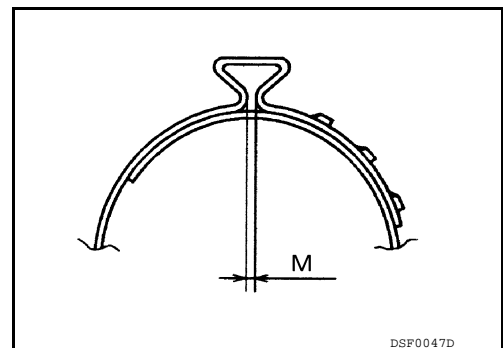

REAR DRIVE SHAFT

< UNIT DISASSEMBLY AND ASSEMBLY >

11. After installing housing and shaft, rotate boot to validate position is correct. If boot position is incorrect, remove boot bands and reposition the boot, then secure with new boot bands.

CAUTION:

Do not reuse boot band.

12. Install a new dust shield.

13. Install a new circular clip.

CAUTION:

Do not reuse circular clip.

SERVICE DATA AND SPECIFICATIONS (SDS)

< SERVICE DATA AND SPECIFICATIONS (SDS)

SERVICE DATA AND SPECIFICATIONS (SDS)

SERVICE DATA AND SPECIFICATIONS (SDS)

Wheel Bearing

INFOID:0000000008507854

Item	Standard
Axial end play	0.05 mm (0.002 in) or less

Drive Shaft

INFOID:0000000008507855

RAX

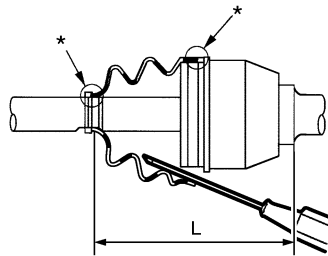

JPDIF0142ZZ

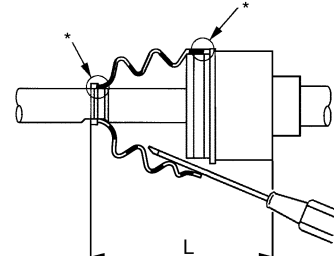

JPDIF0144ZZ

Application	Standard	
Joint type	Wheel side	Final drive side
Grease quantity	55 ± 10 g (1.94 ± 0.35 oz)	60 ± 10 g (2.12 ± 0.35 oz)
Boots installed length	113.5 mm (4.47 in)	118.2 mm (4.65 in)

* : Boot installation grooves

Boot Bands

Unit: mm (in)

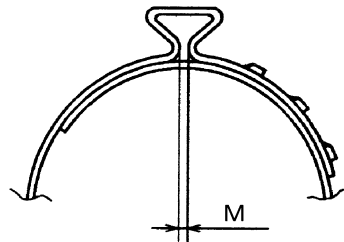

DSP0047D

Dimension (M)	1.0 - 4.0 (0.039 - 0.157)
---------------	---------------------------