

RF
SECTION RF
ROOF

A
 B
 C
 D
 E
 F
 G
 H
 I
 J
 RF
 L
 M
 N
 O
 P

CONTENTS

PRECAUTION	3	RETAINED PWR : CONSULT Function (BCM -	RETAINED PWR)	12
PRECAUTIONS	3	ECU DIAGNOSIS INFORMATION	13	
Precaution for Supplemental Restraint System		BCM (BODY CONTROL MODULE)	13	
(SRS) "AIR BAG" and "SEAT BELT PRE-TENSIONER"	3	List of ECU Reference	13	
Precaution for Work	3	MOONROOF MOTOR ASSEMBLY	14	
PREPARATION	4	Reference Value	14	
PREPARATION	4	SUNSHADE MOTOR ASSEMBLY	15	
Special Service Tool	4	Reference Value	15	
Commercial Service Tools	4	WIRING DIAGRAM	16	
SYSTEM DESCRIPTION	5	MOONROOF SYSTEM	16	
COMPONENT PARTS	5	Wiring Diagram	16	
MOONROOF	5	BASIC INSPECTION	23	
MOONROOF : Component Parts Location	5	DIAGNOSIS AND REPAIR WORKFLOW	23	
MOONROOF : Component Description	5	Work Flow	23	
SUNSHADE	6	INSPECTION AND ADJUSTMENT	25	
SUNSHADE : Component Parts Location	6	ADDITIONAL SERVICE WHEN REPLACING		
SUNSHADE : Component Description	6	CONTROL UNIT	25	
SYSTEM	8	ADDITIONAL SERVICE WHEN REPLACING		
MOONROOF	8	CONTROL UNIT : Special Repair Requirement	25	
MOONROOF : System Diagram	8	DTC/CIRCUIT DIAGNOSIS	26	
MOONROOF : System Description	8	POWER SUPPLY AND GROUND CIRCUIT	26	
SUNSHADE	9	BCM	26	
SUNSHADE : System Diagram	9	BCM : Diagnosis Procedure	26	
SUNSHADE : System Description	9	MOONROOF MOTOR ASSEMBLY	26	
DIAGNOSIS SYSTEM (BCM)	11	MOONROOF MOTOR ASSEMBLY : Description....	26	
COMMON ITEM	11	MOONROOF MOTOR ASSEMBLY :		
COMMON ITEM : CONSULT Function (BCM -		Component Function Check	27	
COMMON ITEM)	11	MOONROOF MOTOR ASSEMBLY :		
RETAINED PWR	11	Diagnosis Procedure	27	

MOONROOF MOTOR ASSEMBLY : Special Repair Requirement	29	SUNSHADE : Diagnosis Procedure	41
SUNSHADE MOTOR ASSEMBLY	30	RETAINED POWER OPERATION DOES NOT OPERATE PROPERLY	42
SUNSHADE MOTOR ASSEMBLY : Description ...	30	Diagnosis Procedure	42
SUNSHADE MOTOR ASSEMBLY :		SQUEAK AND RATTLE TROUBLE DIAGNOSES	43
Component Function Check	30	Work Flow	43
SUNSHADE MOTOR ASSEMBLY :		Generic Squeak and Rattle Troubleshooting	45
Diagnosis Procedure	30	Diagnostic Worksheet	47
MOONROOF SWITCH	32	REMOVAL AND INSTALLATION	49
Description	32	GLASS LID	49
Diagnosis Procedure	32	Removal and Installation	49
Component Inspection	33	MOONROOF MOTOR ASSEMBLY	50
SUNSHADE SWITCH	34	Removal and Installation	50
Description	34	MOONROOF UNIT ASSEMBLY	51
Diagnosis Procedure	34	Inspection	51
Component Inspection	35	Exploded View	55
DOOR SWITCH	36	Removal and Installation	55
Diagnosis Procedure	36	SUNSHADE	57
SYMPTOM DIAGNOSIS	38	FRONT MOONROOF	57
MOONROOF DOES NOT OPERATE PROPERLY	38	FRONT MOONROOF : Removal and Installation...	57
Diagnosis Procedure	38	REAR SUNSHADE UNIT	57
SUNSHADE SYSTEM DOES NOT OPERATE PROPERLY	39	REAR SUNSHADE UNIT : Removal and Installation	58
Diagnosis Procedure	39	SUNSHADE MOTOR ASSEMBLY	59
AUTO OPERATION DOES NOT OPERATE	40	REAR SUNSHADE UNIT	59
MOONROOF	40	REAR SUNSHADE UNIT : Removal and Installation	59
MOONROOF : Diagnosis Procedure	40	WIND DEFLECTOR	60
SUNSHADE	40	Removal and Installation	60
SUNSHADE : Diagnosis Procedure	40	MOONROOF SWITCH	61
ANTI-PINCH FUNCTION DOES NOT OPERATE	41	Removal and Installation	61
MOONROOF	41	SUNSHADE SWITCH	62
MOONROOF : Diagnosis Procedure	41	Removal and Installation	62
SUNSHADE	41		

PRECAUTIONS

< PRECAUTION >

PRECAUTION

PRECAUTIONS

Precaution for Supplemental Restraint System (SRS) "AIR BAG" and "SEAT BELT PRE-TENSIONER"

INFOID:000000008966024

The Supplemental Restraint System such as "AIR BAG" and "SEAT BELT PRE-TENSIONER", used along with a front seat belt, helps to reduce the risk or severity of injury to the driver and front passenger for certain types of collision. Information necessary to service the system safely is included in the SR and SB section of this Service Manual.

WARNING:

- To avoid rendering the SRS inoperative, which could increase the risk of personal injury or death in the event of a collision which would result in air bag inflation, all maintenance must be performed by an authorized NISSAN/INFINITI dealer.
- Improper maintenance, including incorrect removal and installation of the SRS, can lead to personal injury caused by unintentional activation of the system. For removal of Spiral Cable and Air Bag Module, see the SR section.
- Do not use electrical test equipment on any circuit related to the SRS unless instructed to in this Service Manual. SRS wiring harnesses can be identified by yellow and/or orange harnesses or harness connectors.

PRECAUTIONS WHEN USING POWER TOOLS (AIR OR ELECTRIC) AND HAMMERS

WARNING:

- When working near the Airbag Diagnosis Sensor Unit or other Airbag System sensors with the Ignition ON or engine running, DO NOT use air or electric power tools or strike near the sensor(s) with a hammer. Heavy vibration could activate the sensor(s) and deploy the air bag(s), possibly causing serious injury.
- When using air or electric power tools or hammers, always switch the Ignition OFF, disconnect the battery and wait at least 3 minutes before performing any service.

Precaution for Work

INFOID:000000008966025

- When removing or disassembling each component, be careful not to damage or deform it. If a component may be subject to interference, be sure to protect it with a shop cloth.
- When removing (disengaging) components with a screwdriver or similar tool, be sure to wrap the component with a shop cloth or vinyl tape to protect it.
- Protect the removed parts with a shop cloth and prevent them from being dropped.
- Replace a deformed or damaged clip.
- If a part is specified as a non-reusable part, always replace it with a new one.
- Be sure to tighten bolts and nuts securely to the specified torque.
- After installation is complete, be sure to check that each part works properly.
- Follow the steps below to clean components:
 - Water soluble dirt:
 - Dip a soft cloth into lukewarm water, wring the water out of the cloth and wipe the dirty area.
 - Then rub with a soft, dry cloth.
 - Oily dirt:
 - Dip a soft cloth into lukewarm water with mild detergent (concentration: within 2 to 3%) and wipe the dirty area.
 - Then dip a cloth into fresh water, wring the water out of the cloth and wipe the detergent off.
 - Then rub with a soft, dry cloth.
 - Do not use organic solvent such as thinner, benzene, alcohol or gasoline.
 - For genuine leather seats, use a genuine leather seat cleaner.

PREPARATION

< PREPARATION >

PREPARATION

PREPARATION

Special Service Tool

INFOID:000000008511378

The actual shapes of Kent-Moore tools may differ from those of special service tools illustrated here.

Tool number (Kent-Moore No.) Tool name	Description
— (J-39570) Chassis ear	Locating the noise
— (J-43980) NISSAN Squeak and Rattle Kit	Repairing the cause of noise
— (J-46534) Trim tool set	Removing trim components

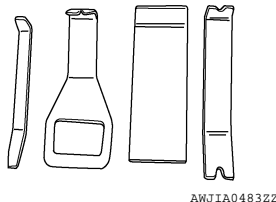
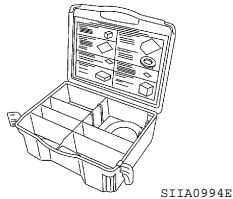
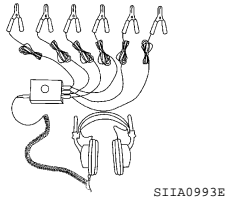

Commercial Service Tools

INFOID:000000008511379

(Kent-Moore No.) Tool name	Description
(J-39565) Engine ear	Locating the noise
(—) Power tool	Loosening nuts, screws and bolts

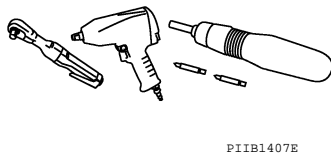
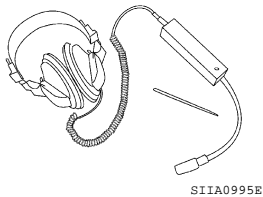

COMPONENT PARTS

< SYSTEM DESCRIPTION >

SYSTEM DESCRIPTION

COMPONENT PARTS

MOONROOF

MOONROOF : Component Parts Location

INFOID:000000008511380

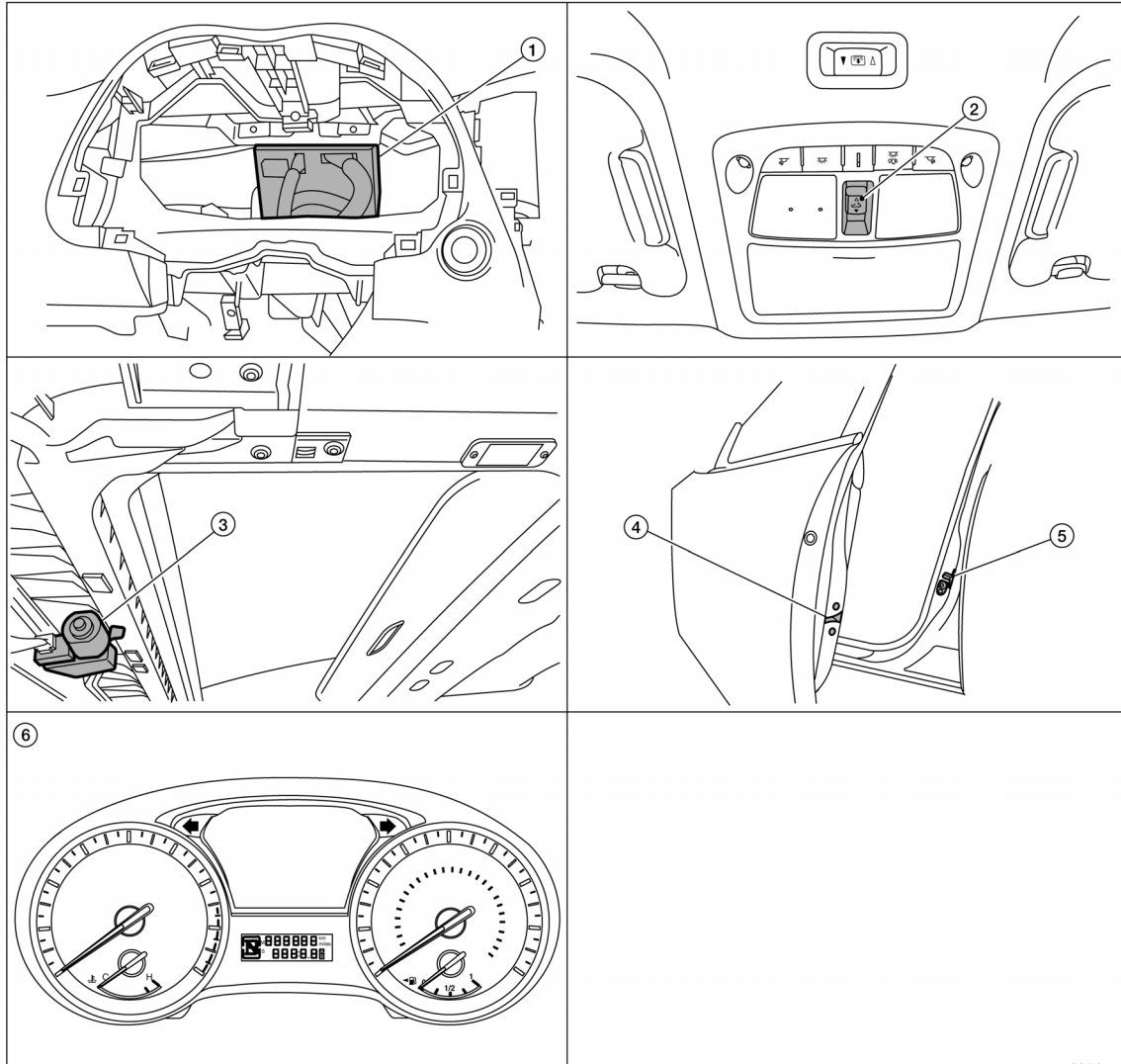

AWKIA20542Z

- | | | |
|--|--------------------------------------|--|
| 1. BCM
(view with combination meter removed) | 2. Moonroof switch | 3. Moonroof motor assembly (view with headliner removed) |
| 4. Front door lock assembly LH (key cylinder switch) | 5. Front door switch LH (RH similar) | 6. Combination meter |

MOONROOF : Component Description

INFOID:000000008511381

Component	Function
BCM	Supplies the power supply to moonroof motor assembly.
Moonroof switch	Transmits tilt up/down & slides open/close operation signal to moonroof motor assembly.
Moonroof motor assembly	The moonroof motor and CPU are integrated into one unit that enables tilt up/down & slide open/close by moonroof switch operation.

A
B
C
D
E
F
G
H
I
J
RF
L
M
N
O
P

COMPONENT PARTS

< SYSTEM DESCRIPTION >

Component	Function
Front door switch	Detects door open/close condition and transmits to BCM.
Combination meter	Transmits vehicle speed signal to moonroof motor assembly.

SUNSHADE

SUNSHADE : Component Parts Location

INFOID:000000008511382

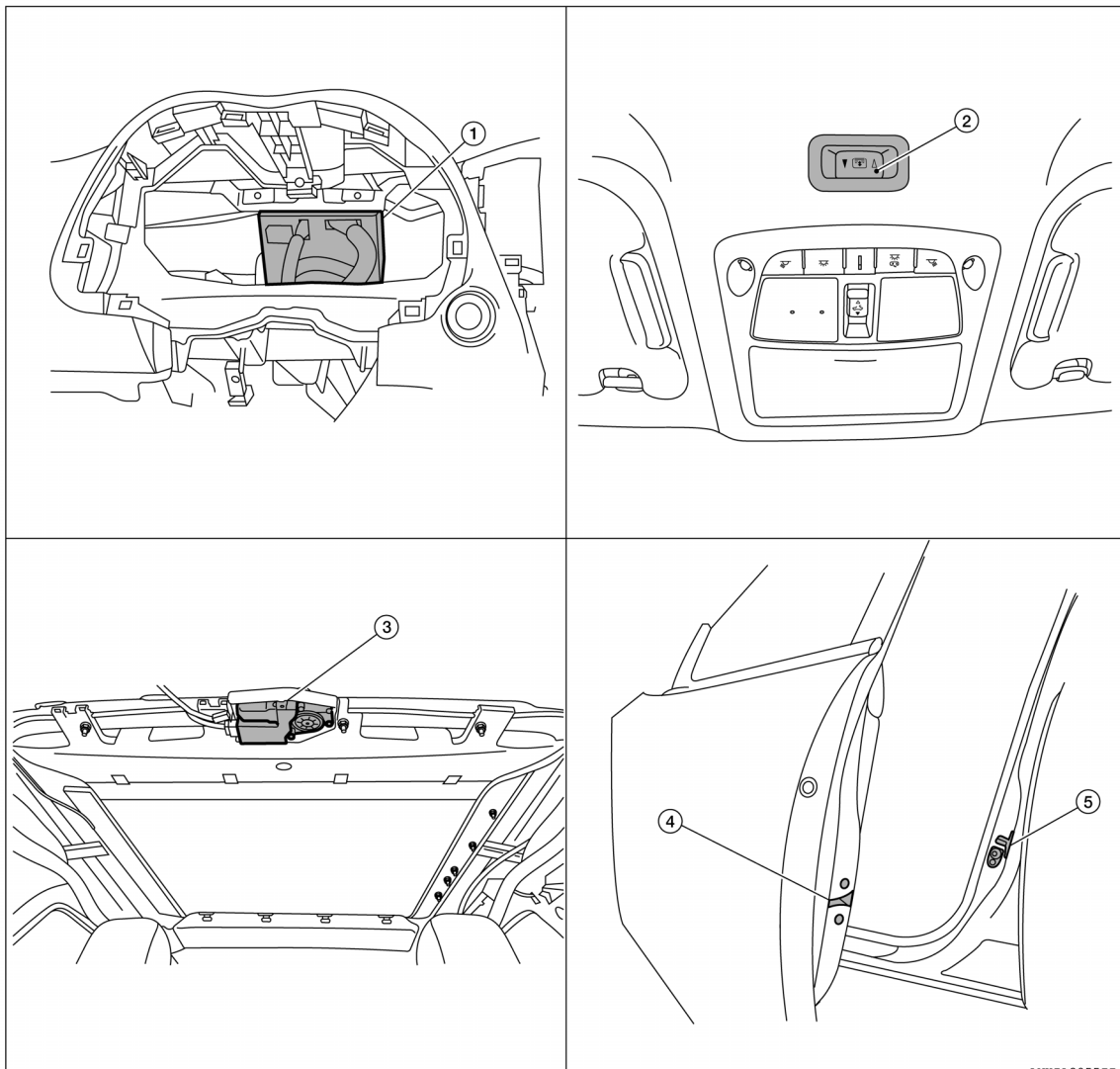

- 1. BCM (view with combination meter removed)
- 2. Sunshade switch
- 3. Sunshade motor assembly (view with headliner removed)
- 4. Front door lock assembly LH (key cylinder switch)
- 5. Front door switch LH (RH similar)

SUNSHADE : Component Description

INFOID:000000008511383

Component	Function
BCM	Supplies power to the sunshade motor assembly.
Sunshade motor assembly	The sunshade motor is activated with a signal from the sunshade switch.

COMPONENT PARTS

< SYSTEM DESCRIPTION >

Component	Function
Sunshade switch	Transmits switch operation signal to the sunshade motor assembly.
Front door switches	Detects door open/close condition and transmits to BCM.

A

B

C

D

E

F

G

H

I

J

RF

L

M

N

O

P

SYSTEM

< SYSTEM DESCRIPTION >

SYSTEM MOONROOF

MOONROOF : System Diagram

INFOID:000000008511384

MOONROOF

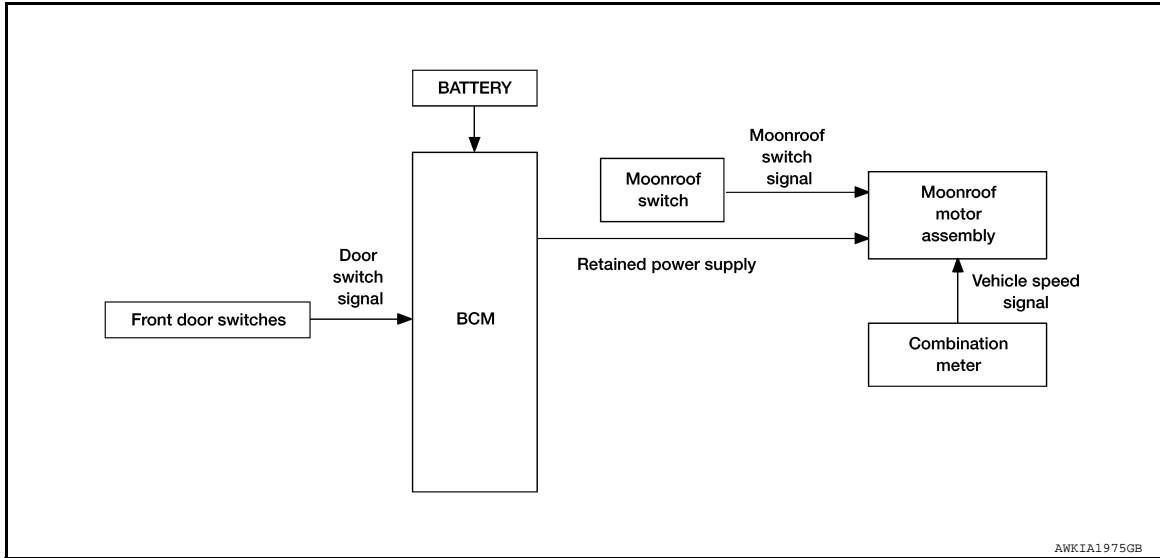

MOONROOF : System Description

INFOID:000000008511385

MOONROOF SYSTEM INPUT/OUTPUT SIGNAL CHART

Item	Input signal to moonroof motor assembly	Moonroof motor function	Actuator
Moonroof switch	Moonroof switch signal (tilt down or slide open)	Receives signal and moves the moonroof assembly to the correct position.	Moonroof motor
	Moonroof switch signal (tilt up or slide close)		
Combination meter	Vehicle speed signal	Receives speed signal and determines the amount of torque the motor requires.	
BCM	RAP signal	Retained power after the key is turned off and the front doors stay closed.	

MOONROOF OPERATION

- Moonroof motor assembly operates with the power supply that is output from BCM while ignition switch is ON or retained power is operating.
- Tilt up/down & slide open/close signals from moonroof switch enable the moonroof motor to move.
- Moonroof motor assembly receives a vehicle speed signal from combination meter and controls the moonroof motor torque of tilt down at the time of high speed operation.

AUTO OPERATION

Moonroof AUTO feature makes it possible to slide open and slide closed or tilt up and tilt down the moonroof without holding the moonroof switch in the slide open/tilt down or slide close/tilt up position.

RETAINED POWER OPERATION

- Retained power operation is an additional power supply function that enables the moonroof system to operate for 45 seconds after the ignition switch is turned off and the front doors remain closed.

Retained power function cancel conditions

SYSTEM

< SYSTEM DESCRIPTION >

- Door CLOSE (door switch OFF)→OPEN (door switch ON).
- When ignition switch is ON again.
- When timer time passes (45 seconds).

ANTI-PINCH FUNCTION

The moonroof motor's built in CPU monitors the moonroof motor operation and position.

If a restriction is detected during the slide closed or tilt down operation the moonroof motor will move the glass in the open positions. The moonroof will operate until full up position (when tilt down operates) or 125 mm (4.92 in.) or more in the open direction.

SUNSHADE

SUNSHADE : System Diagram

INFOID:000000008511386

SUNSHADE

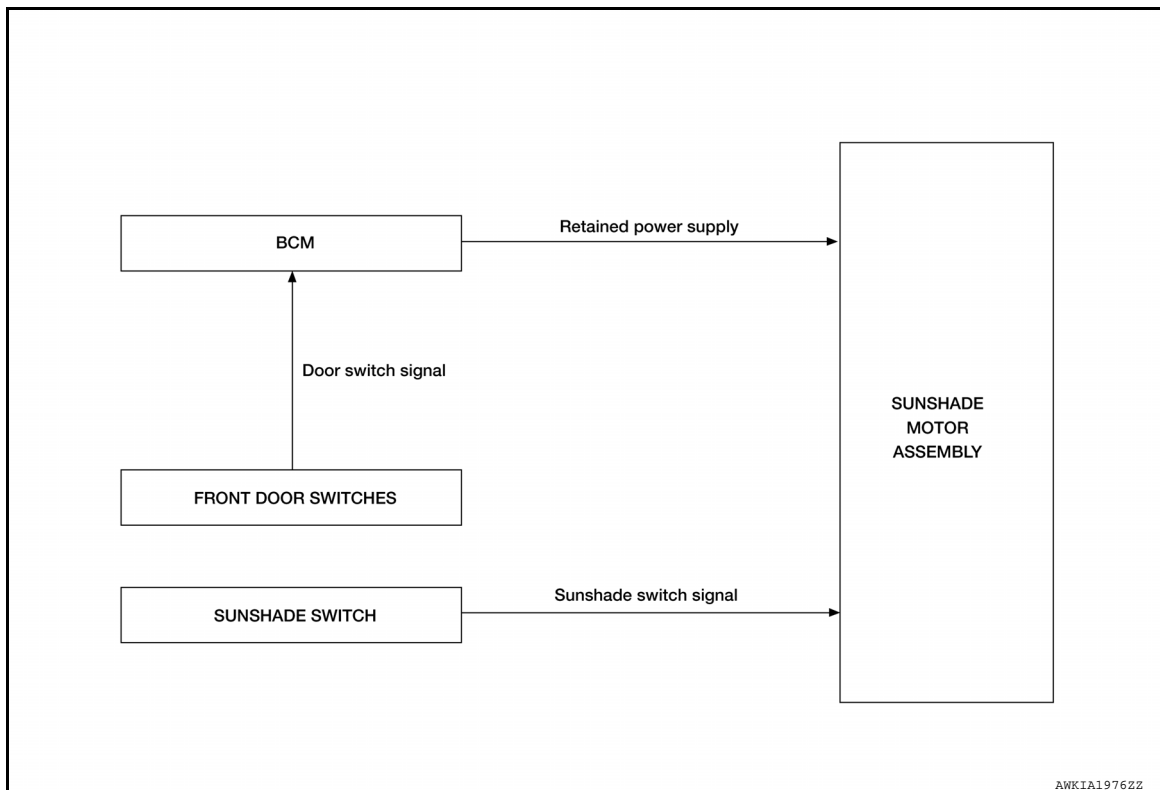

SUNSHADE : System Description

INFOID:000000008511387

DESCRIPTION

- The BCM supplies power to the sunshade motor assembly while the ignition is ON or retained power is operating.
- The sunshade switch can be operated in the directions of open (1) and close (2).

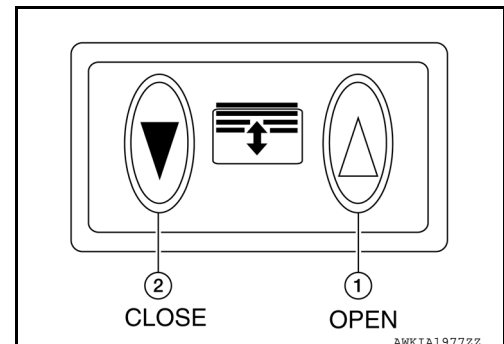

AUTO OPERATION

A
B
C
D
E
F
G
H
I
J
RF
L
M
N
O
P

SYSTEM

< SYSTEM DESCRIPTION >

Sunshade moves to the fully-open or fully-close position by pressing and releasing the sunshade switch. OPEN (1) or CLOSE (2) position.

RETAINED POWER OPERATION

Retained power operation is an additional power supply function that enables the sunshade system to operate for 45 seconds after ignition switch is turned OFF.

Retained power function cancel conditions

- Front door CLOSE (door switch OFF)→OPEN (door switch ON)
- Ignition switch is ON again.
- Timer passed (45 seconds)

ANTI-PINCH FUNCTION

CAUTION:

There are some small distances immediately before the closed position which cannot be detected.

- The CPU is built inside the sunshade motor assembly. It monitors the sunshade condition by the signals from sunshade motor. When the sunshade motor assembly detects an interruption during auto close operation, a signal is sent to the CPU to open the sunshade.

DIAGNOSIS SYSTEM (BCM)

< SYSTEM DESCRIPTION >

DIAGNOSIS SYSTEM (BCM) COMMON ITEM

COMMON ITEM : CONSULT Function (BCM - COMMON ITEM)

INFOID:000000008843163

APPLICATION ITEM

CONSULT performs the following functions via CAN communication with BCM.

Direct Diagnostic Mode	Description
Ecu Identification	The BCM part number is displayed.
Self Diagnostic Result	The BCM self diagnostic results are displayed.
Data Monitor	The BCM input/output data is displayed in real time.
Active Test	The BCM activates outputs to test components.
Work support	The settings for BCM functions can be changed.
Configuration	<ul style="list-style-type: none"> The vehicle specification can be read and saved. The vehicle specification can be written when replacing BCM.
CAN Diag Support Mntr	The result of transmit/receive diagnosis of CAN communication is displayed.

SYSTEM APPLICATION

BCM can perform the following functions.

System	Sub System	Direct Diagnostic Mode						
		Ecu Identification	Self Diagnostic Result	Data Monitor	Active Test	Work support	Configuration	CAN Diag Support Mntr
Door lock	DOOR LOCK		×	×	×	×		
Rear window defogger	REAR DEFOGGER			×	×	×		
Warning chime	BUZZER			×	×			
Interior room lamp timer	INT LAMP			×	×	×		
Exterior lamp	HEADLAMP			×	×	×		
Wiper and washer	WIPER			×	×	×		
Turn signal and hazard warning lamps	FLASHER			×	×			
Air conditioner	AIR CONDITIONER			×				
Intelligent Key system	INTELLIGENT KEY		×	×	×	×		
Combination switch	COMB SW			×				
BCM	BCM	×	×			×	×	×
Immobilizer	IMMU		×	×	×			
Interior room lamp battery saver	BATTERY SAVER			×	×			
Back door open	TRUNK			×				
Vehicle security system	THEFT ALM			×	×	×		
RAP system	RETAINED PWR			×				
Signal buffer system	SIGNAL BUFFER			×				
TPMS	AIR PRESSURE MONITOR		×	×	×	×		

RETAINED PWR

A
B
C
D
E
F
G
H
I
J
RF
L
M
N
O
P

DIAGNOSIS SYSTEM (BCM)

< SYSTEM DESCRIPTION >

RETAINED PWR : CONSULT Function (BCM - RETAINED PWR)

INFOID:000000008843164

DATA MONITOR

Monitor Item [Unit]	Description
DOOR SW-DR [On/Off]	Indicates condition of front door switch LH.
DOOR SW-AS [On/Off]	Indicates condition of front door switch RH.

BCM (BODY CONTROL MODULE)

< ECU DIAGNOSIS INFORMATION >

ECU DIAGNOSIS INFORMATION

BCM (BODY CONTROL MODULE)

List of ECU Reference

INFOID:000000008511390

ECU	Reference
BCM	BCS-28, "Reference Value"
	BCS-48, "Fail Safe"
	BCS-48, "DTC Inspection Priority Chart"
	BCS-50, "DTC Index"

A
B
C
D
E
F
G
H
I
J
RF
L
M
N
O
P

MOONROOF MOTOR ASSEMBLY

< ECU DIAGNOSIS INFORMATION >

MOONROOF MOTOR ASSEMBLY

Reference Value

INFOID:000000008511391

TERMINAL LAYOUT

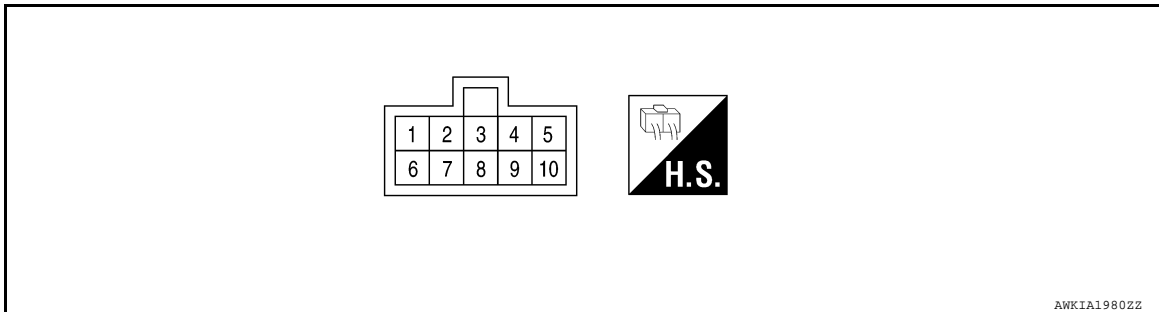

PHYSICAL VALUES

Terminal No. (Wire color)		Description		Condition	Voltage (Approx.)
+	-	Signal name	Input/ Output		
1 (BR)	Ground	Moonroof close switch signal	Input	Moonroof switch in following po- sition • TILT UP • SLIDE CLOSE	0
				Other than above	Battery voltage
5 (V)	Ground	Moonroof open switch signal	Input	Moonroof switch in following po- sition • TILT DOWN • SLIDE OPEN	0
				Other than above	Battery voltage
7 (LG)	Ground	Moonroof power supply	Input	—	Battery voltage
8 (SB)	Ground	Vehicle speed signal (2- pulse)	Input	Speedometer operated [When vehicle speed is approx.40km/ h (25MPH)]	<p style="text-align: right;">ELF1080D</p>
9 (Y)	Ground	RAP signal	Input	Ignition switch ON	Battery voltage
				Within 45 seconds after ignition switch is turned to OFF.	Battery voltage
				When driver side or passenger side door is opened during re- tained power operation.	0
10 (B)	Ground	Ground	—	—	0

SUNSHADE MOTOR ASSEMBLY

< ECU DIAGNOSIS INFORMATION >

SUNSHADE MOTOR ASSEMBLY

Reference Value

INFOID:000000008511392

TERMINAL LAYOUT

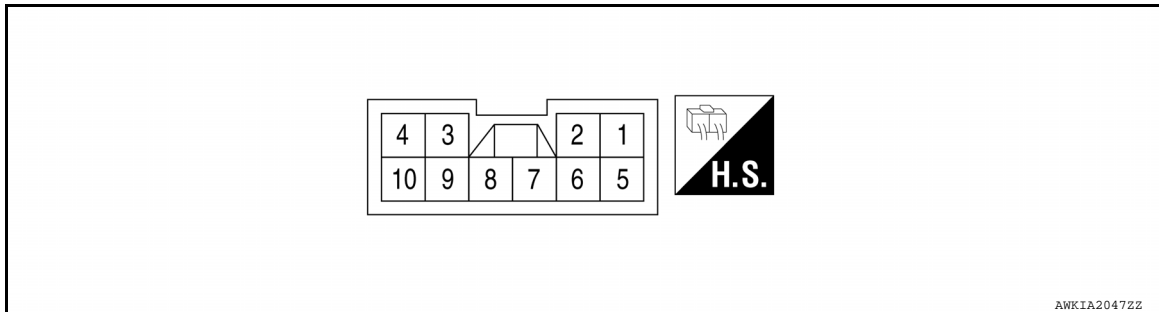

PHYSICAL VALUES

Terminal No. (Wire color)		Description	Condition	Voltage (Approx.)
+	-	Signal name	Input/ Output	
2 (LG)	Ground	Sunshade close switch signal	Input	Sunshade switch is in the close position 0 Other than above Battery voltage
4 (LG)	Ground	RAP signal	Input	Within 45 seconds after the ignition is turned off Battery voltage When the driver side or passenger side door is opened during retained power operation. 0
6 (Y)	Ground	Sunshade open switch signal	Input	Sunshade switch is in the open position 0 Other than above Battery voltage
8 (B)	Ground	Ground	—	— 0
10 (Y)	Ground	Sunshade power supply	—	— Battery voltage

MOONROOF SYSTEM

< WIRING DIAGRAM >

MOONROOF SYSTEM CONNECTORS

Connector No.	M1
Connector Name	WIRE TO WIRE
Connector Color	WHITE

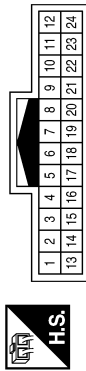

Terminal No.	Color of Wire	Signal Name
5	B	-
11	BR	-
21	LG	-
22	Y	-

Connector No.	M20
Connector Name	BCM (BODY CONTROL MODULE)
Connector Color	GRAY

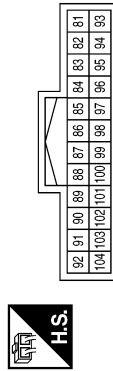

Terminal No.	Color of Wire	Signal Name
94	G	AS DOOR SW
96	BG	DR DOOR SW

Connector No.	M2
Connector Name	WIRE TO WIRE
Connector Color	WHITE

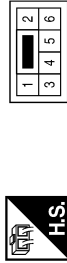

Terminal No.	Color of Wire	Signal Name
1	BR	-
2	Y	-
6	GR	-

Connector No.	M24
Connector Name	COMBINATION METER
Connector Color	WHITE

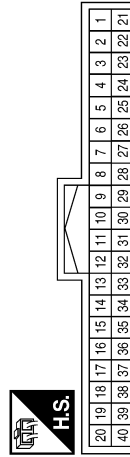

Terminal No.	Color of Wire	Signal Name
33	BR	SPEED 2P/R

Connector No.	M3
Connector Name	FUSE BLOCK (J/B)
Connector Color	WHITE

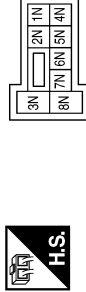

Terminal No.	Color of Wire	Signal Name
6N	W	-

Connector No.	M31
Connector Name	WIRE TO WIRE
Connector Color	WHITE

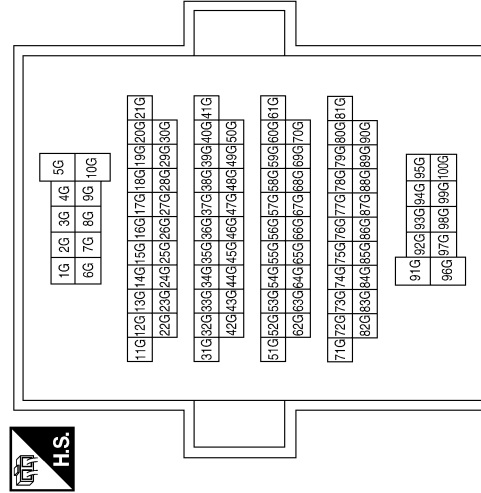

Terminal No.	Color of Wire	Signal Name
10G	W	-

A
B
C
D
E
F
G
H
I
J
RF
L
M
N
O
P

MOONROOF SYSTEM

< WIRING DIAGRAM >

Connector No.	M74
Connector Name	WIRE TO WIRE
Connector Color	BROWN

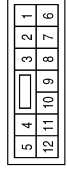

Terminal No.	Color of Wire	Signal Name
4	BR	-
5	Y	-

Terminal No.	Color of Wire	Signal Name
66A	BG	-
83A	Y	-
84A	LG	-

Connector No.	M40
Connector Name	WIRE TO WIRE
Connector Color	WHITE

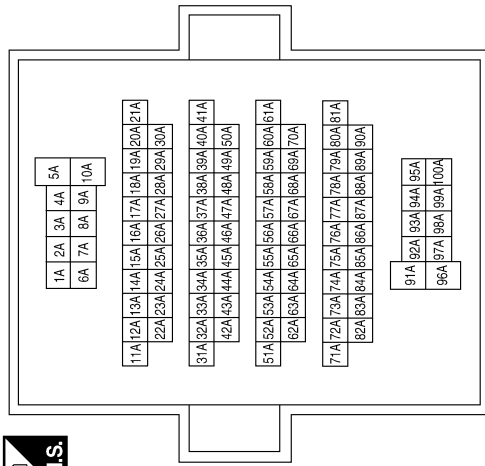

Connector No.	M181
Connector Name	JOINT CONNECTOR - M36
Connector Color	WHITE



Terminal No.	Color of Wire	Signal Name
1	W	-
2	W	-

Connector No.	M84
Connector Name	WIRE TO WIRE
Connector Color	WHITE

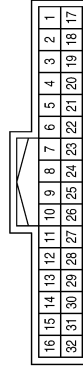

Terminal No.	Color of Wire	Signal Name
21	G	-

Connector No.	M81
Connector Name	BCM (BODY CONTROL MODULE)
Connector Color	WHITE

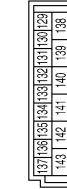

Terminal No.	Color of Wire	Signal Name
131	W	BAT BCM FUSE
134	B	GND 2
139	W	BAT-POWER F/L
140	BR	P/W POWER SUPPLY IGN
141	Y	P/W POWER SUPPLY BAT
143	B	GND 1

AAKIA0964GB

MOONROOF SYSTEM

< WIRING DIAGRAM >

Connector No.	B42
Connector Name	WIRE TO WIRE
Connector Color	BROWN

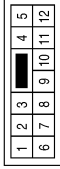

Terminal No.	Color of Wire	Signal Name
4	LG	-
5	Y	-

Connector No.	B8
Connector Name	FRONT DOOR SWITCH LH
Connector Color	WHITE

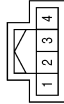

Terminal No.	Color of Wire	Signal Name
3	L	-

Connector No.	E152
Connector Name	WIRE TO WIRE
Connector Color	WHITE

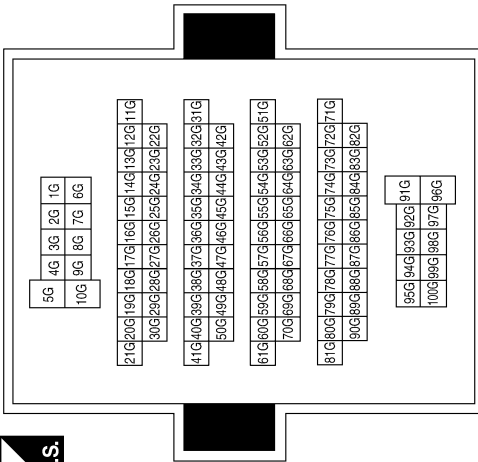

Terminal No.	Color of Wire	Signal Name
10G	P	-

A
B
C
D
E
F
G
H
I
J
L
M
N
O
P

RF

MOONROOF SYSTEM

< WIRING DIAGRAM >

Connector No.	B85
Connector Name	SUNSHADE MOTOR ASSEMBLY
Connector Color	WHITE

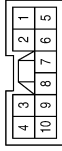

Terminal No.	Color of Wire	Signal Name
2	LG	-
4	LG	-
6	Y	-
8	B	-
10	Y	-

Terminal No.	Color of Wire	Signal Name
66A	L	-
83A	Y	-
84A	LG	-

Connector No.	B69
Connector Name	WIRE TO WIRE
Connector Color	WHITE

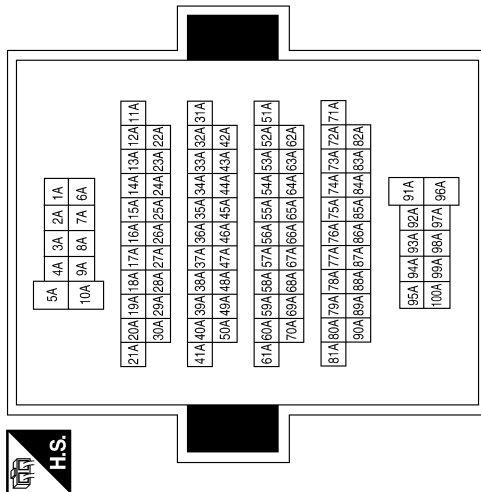

Connector No.	B108
Connector Name	FRONT DOOR SWITCH RH
Connector Color	WHITE



Terminal No.	Color of Wire	Signal Name
3	LG	-

Connector No.	B101
Connector Name	WIRE TO WIRE
Connector Color	WHITE

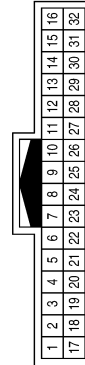

Terminal No.	Color of Wire	Signal Name
21	LG	-

AAKIA0966GB

MOONROOF SYSTEM

< WIRING DIAGRAM >

Connector No.	R4
Connector Name	MOONROOF MOTOR ASSEMBLY
Connector Color	GRAY

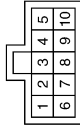

Terminal No.	Color of Wire	Signal Name
1	BR	-
5	V	-
7	LG	-
8	SB	-
9	Y	-
10	B	-

Connector No.	R2
Connector Name	WIRE TO WIRE
Connector Color	WHITE



Terminal No.	Color of Wire	Signal Name
1	Y	-
2	LG	-
6	B	-

Connector No.	R1
Connector Name	WIRE TO WIRE
Connector Color	WHITE

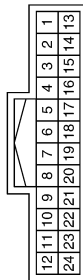

Terminal No.	Color of Wire	Signal Name
5	B	-
11	SB	-
21	SB	-
22	L	-

Connector No.	R108
Connector Name	MOONROOF SWITCH
Connector Color	WHITE

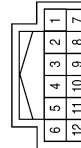

Terminal No.	Color of Wire	Signal Name
3	V	-
6	B	-
10	BR	-

Connector No.	R101
Connector Name	WIRE TO WIRE
Connector Color	WHITE

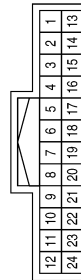

Terminal No.	Color of Wire	Signal Name
8	B	-
15	L	-
16	SB	-
23	BR	-
24	V	-

Connector No.	R11
Connector Name	WIRE TO WIRE
Connector Color	WHITE



Terminal No.	Color of Wire	Signal Name
8	B	-
15	L	-
16	SB	-
23	BR	-
24	V	-

AAKIA0967GB

A
B
C
D
E
F
G
H
I
J
RF
L
M
N
O
P

MOONROOF SYSTEM

< WIRING DIAGRAM >

Connector No.	RT110
Connector Name	SUNSHADE SWITCH
Connector Color	WHITE

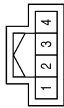

Terminal No.	Color of Wire	Signal Name
1	L	-
2	B	-
3	SB	-

AAKIA0968GB

DIAGNOSIS AND REPAIR WORKFLOW

< BASIC INSPECTION >

BASIC INSPECTION

DIAGNOSIS AND REPAIR WORKFLOW

Work Flow

INFOID:000000008511394

OVERALL SEQUENCE

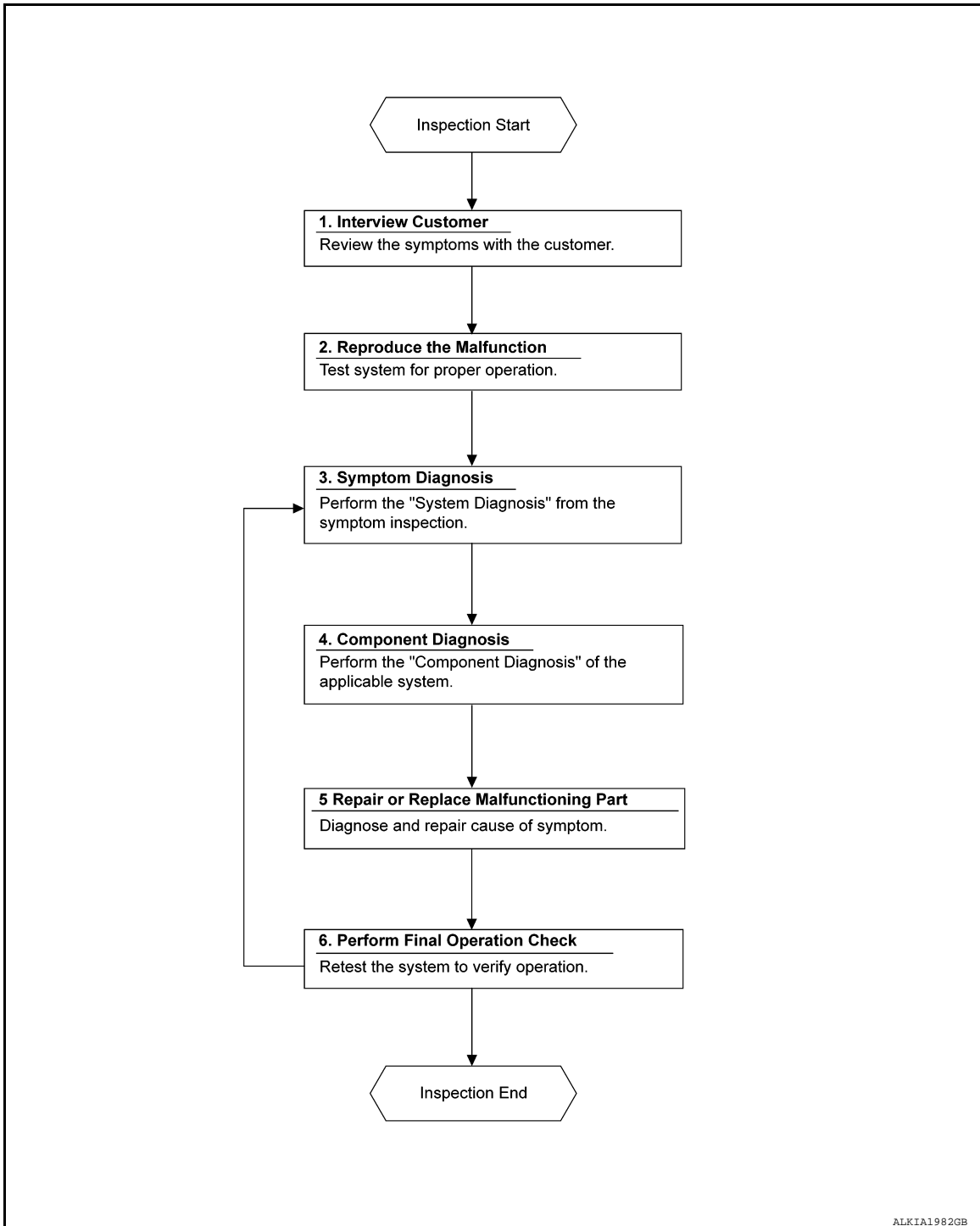

DETAILED FLOW

1. OBTAIN INFORMATION ABOUT SYMPTOM

Interview the customer to obtain as much information as possible about the conditions and environment under which the malfunction occurred.

A
B
C
D
E
F
G
H
I
J
RF
L
M
N
O
P

DIAGNOSIS AND REPAIR WORKFLOW

< BASIC INSPECTION >

>> GO TO 2.

2. CONFIRM CONCERN

Check the malfunction on the vehicle that the customer describes.
Inspect the relation of the symptoms and the condition when the symptoms occur.

>> GO TO 3.

3. IDENTIFY THE MALFUNCTIONING SYSTEM WITH SYMPTOM DIAGNOSIS

Use Symptom diagnosis from the symptom inspection result in step 2 and then identify where to start performing the diagnosis based on possible causes and symptoms.

>> GO TO 4.

4. PERFORM THE COMPONENT DIAGNOSIS OF THE APPLICABLE SYSTEM

Perform the diagnosis with Component diagnosis of the applicable system.

>> GO TO 5.

5. REPAIR OR REPLACE THE MALFUNCTIONING PARTS

Repair or replace the specified malfunctioning parts.

>> GO TO 6.

6. FINAL CHECK

Check that malfunctions are not reproduced when obtaining the malfunction information from the customer, referring to the symptom inspection result in step 2.

Are the malfunctions corrected?

YES >> Inspection End.

NO >> GO TO 3.

INSPECTION AND ADJUSTMENT

< BASIC INSPECTION >

INSPECTION AND ADJUSTMENT

ADDITIONAL SERVICE WHEN REPLACING CONTROL UNIT

ADDITIONAL SERVICE WHEN REPLACING CONTROL UNIT : Special Repair Requirement

INFOID:000000008511395

INITIALIZATION PROCEDURE

Moonroof

If the moonroof does not open or close automatically, use the following procedure to return moonroof operation to normal.

1. Turn ignition switch ON.
2. Push and hold the moonroof tilt switch forward until the moonroof stops.
3. Release the moonroof switch.
4. Press and hold the tilt up switch within 6 seconds.
5. The roof glass will Tilt-Down → Slide-Close → Slide-Open → Slide-Close → Tilt-Up → Tilt-Down.
6. Release the switch, initialization is complete if the moonroof operates normally.

Sunshade

If the sunshade does not open or close automatically, use the following procedure to return sunshade operation to normal.

1. Switch the vehicle ignition to the ACCESSORY or RUN mode.
2. Press and hold the sunshade close switch.
3. Sunshade will begin moving towards the close position only while the switch is continually pressed. (this disables the obstacle detection).
4. Sunshade will stop for about 4 seconds.
5. Sunshade drive cable will travel in the open direction for 10 mm (.394 in.) then reverse direction and stop at the normal close position.
6. Release the sunshade close switch. Initialization procedure is complete.

ANTI-PINCH FUNCTION

Moonroof

1. Fully open the moonroof to the full open position.
2. Place a piece of wood at the fully closed position.
3. Close the moonroof completely with auto-slide close function.
4. Moonroof should make contact and then tilt up or travel in reverse for 125mm (4.92 in.).

Sunshade

1. Open the sunshade to the full open position.
2. Place a piece of wood at the fully closed position.
3. Close the sunshade completely with auto-slide close function.
4. Sunshade should make contact and then travel in reverse for 100mm (3.94 in.).

CAUTION:

- Do not test the anti-pinch function with your hands or other body parts because they may be pinched.
- Depending on the environment and driving conditions, if a similar impact or load is applied to the moonroof it may lower.
- Test the auto-slide operation before inspection when the initialization procedure is performed.
- Perform the initialization procedure when the auto-slide operation or anti-pinch function does not operate normally.

POWER SUPPLY AND GROUND CIRCUIT

< DTC/CIRCUIT DIAGNOSIS >

DTC/CIRCUIT DIAGNOSIS

POWER SUPPLY AND GROUND CIRCUIT

BCM

BCM : Diagnosis Procedure

INFOID:000000008843166

Regarding Wiring Diagram information, refer to [BCS-53, "Wiring Diagram"](#).

1. CHECK FUSE AND FUSIBLE LINK

Check that the following fuse and fusible link are not blown.

Terminal No.	Signal name	Fuse and fusible link No.
139	Fusible link battery power	O (40A)
131	BCM battery fuse	1 (10A)

Is the fuse or fusible link blown?

YES >> Replace the blown fuse or fusible link after repairing the affected circuit.

NO >> GO TO 2

2. CHECK POWER SUPPLY CIRCUIT

1. Disconnect BCM connector M81.
2. Check voltage between BCM connector M81 terminals 131, 139 and ground.

BCM		Ground	Voltage (Approx.)
Connector	Terminal		
M81	131	—	Battery voltage
	139		

Is the inspection result normal?

YES >> GO TO 3

NO >> Repair or replace harness or connectors.

3. CHECK GROUND CIRCUIT

Check continuity between BCM connector M81 terminals 134, 143 and ground.

BCM		Ground	Continuity
Connector	Terminal		
M81	134	—	Yes
	143		

Is the inspection result normal?

YES >> Inspection End.

NO >> Repair or replace harness or connectors.

MOONROOF MOTOR ASSEMBLY

MOONROOF MOTOR ASSEMBLY : Description

INFOID:000000008511397

- BCM supplies the moonroof motor assembly with power.
- CPU is integrated in moonroof motor assembly.
- Tilts up/down & slides open/close by moonroof switch operation.
- In order to close the moonroof during high speed driving, the Combination meter will send a speed signal to the moonroof CPU to adjust the torque of the motor during the tilt-down operation.

POWER SUPPLY AND GROUND CIRCUIT

< DTC/CIRCUIT DIAGNOSIS >

MOONROOF MOTOR ASSEMBLY : Component Function Check

INFOID:000000008511398

1. CHECK MOONROOF MOTOR FUNCTION

Does the tilt up/down & slide open/close functions operate normally with moonroof switch?

Is the inspection result normal?

YES >> Moonroof motor assembly is OK.

NO >> Refer to [RF-27. "MOONROOF MOTOR ASSEMBLY : Diagnosis Procedure"](#).

MOONROOF MOTOR ASSEMBLY : Diagnosis Procedure

INFOID:000000008511399

Regarding Wiring Diagram information, refer to [RF-16. "Wiring Diagram"](#).

MOONROOF MOTOR ASSEMBLY

1. CHECK POWER SUPPLY CIRCUIT

1. Turn ignition switch OFF.
2. Disconnect the moonroof motor assembly connector.
3. Turn ignition switch ON.
4. Check voltage between moonroof motor assembly connector and ground.

Terminal		Voltage (Approx.)
(+)	(-)	
Moonroof motor assembly connector	Terminal	Battery voltage
R4	7	
	9	

Is the inspection result normal?

YES >> GO TO 2.

NO >> GO TO 3.

2. CHECK GROUND CIRCUIT

1. Turn ignition switch OFF.
2. Check continuity between moonroof motor assembly connector and ground.

Moonroof motor assembly connector	Terminal	Ground	Continuity
R4	10		Yes

Is the inspection result normal?

YES >> GO TO 5.

NO >> Repair or replace harness.

3. CHECK MOONROOF MOTOR CIRCUIT

1. Turn ignition switch OFF.
2. Disconnect the BCM connector.
3. Check continuity between BCM connector and moonroof motor assembly connector.

BCM connector	Terminal	Moonroof motor assembly connector	Terminal	Continuity
M81	140	R4	9	Yes
	141		7	

4. Check continuity between BCM connector and ground.

POWER SUPPLY AND GROUND CIRCUIT

< DTC/CIRCUIT DIAGNOSIS >

BCM connector	Terminal	Ground	Continuity	
M81	140			No
	141			

Is the inspection result normal?

YES >> GO TO 4.

NO >> Repair or replace harness.

4. CHECK BCM OUTPUT SIGNAL

1. Connect the BCM connector.
2. Turn ignition switch ON.
3. Check voltage between BCM connector and ground.

Terminals		(-)	Voltage (Approx.)
(+)	Terminal		
BCM connector	Terminal	Ground	Battery voltage
M81	140		
	141		

Is the inspection result normal?

YES >> Check condition of harness and connector.

NO >> Replace BCM. Refer to [BCS-78, "Removal and Installation"](#).

5. CHECK MOONROOF SWITCH INPUT SIGNAL

1. Connect moonroof motor assembly.
2. Turn ignition switch ON.
3. Check voltage between the moonroof motor assembly connector and ground.

Moonroof motor assembly connector	Terminals		Condition	Voltage (Approx.)
	(+)	(-)		
R4	5	Ground	Moonroof switch is operated TILT DOWN or SLIDE OPEN	0
			Other than above	Battery voltage
	1		Moonroof switch is operated TILT UP or SLIDE CLOSE	0
			Other than above	Battery voltage

Is the inspection result normal?

YES >> GO TO 8.

NO >> GO TO 6.

6. CHECK MOONROOF SWITCH CIRCUIT

1. Turn ignition switch OFF.
2. Disconnect the moonroof motor assembly and moonroof switch.
3. Check continuity between the moonroof motor assembly connector and moonroof switch connector.

Moonroof motor assembly connector	Terminal	Moonroof switch connector	Terminal	Continuity
R4	5	R108	3	Yes
	1		10	

4. Check continuity between the moonroof motor assembly connector and ground.

Moonroof motor assembly connector	Terminal	Ground	Continuity	
R4	5			No
	1			

Is the inspection result normal?

POWER SUPPLY AND GROUND CIRCUIT

< DTC/CIRCUIT DIAGNOSIS >

- YES >> GO TO 7.
 NO >> Repair or replace harness.

7. CHECK MOONROOF SWITCH GROUND CIRCUIT

1. Connect moonroof motor assembly.
2. Check continuity between the moonroof switch connector and ground.

Moonroof switch connector	Terminal	Ground	Continuity
R108	6		Yes

Is the inspection result normal?

- YES >> Refer to [RF-33, "Component Inspection"](#).
 NO >> Repair or replace harness.

8. CHECK COMBINATION METER SIGNAL

1. Connect the moonroof motor assembly connector.
2. Turn ignition switch ON.
3. Check the signal between the moonroof motor assembly connector and ground with oscilloscope.

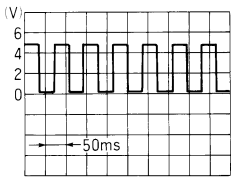
Terminals		Condition	Signal (Reference value)
(+)	(-)		
Moonroof motor assembly connector	Terminal	Speedometer operated [When vehicle speed is approx.40km/h (25MPH)]	
R4	8		

Is the inspection result normal?

- YES >> Replace moonroof motor assembly. Refer to [RF-55, "Removal and Installation"](#). After that, refer to [RF-25, "ADDITIONAL SERVICE WHEN REPLACING CONTROL UNIT : Special Repair Requirement"](#).
 NO >> GO TO 9.

9. CHECK COMBINATION METER CIRCUIT

1. Turn ignition switch OFF.
2. Disconnect combination meter.
3. Check continuity between the combination meter connector and the moonroof motor assembly connector.

Combination meter connector	Terminal	Moonroof motor assembly connector	Terminal	Continuity
M24	33	R4	8	Yes

4. Check continuity between the combination meter connector and ground.

Combination meter connector	Terminal	Ground	Continuity
M24	33		No

Is the inspection result normal?

- YES >> Replace combination meter. Refer to [MWI-82, "Removal and Installation"](#).
 NO >> Repair or replace harness.

MOONROOF MOTOR ASSEMBLY : Special Repair Requirement

INFOID:000000008511400

1. PERFORM INITIALIZATION PROCEDURE

Perform the initialization procedure.

POWER SUPPLY AND GROUND CIRCUIT

< DTC/CIRCUIT DIAGNOSIS >

Refer to [RF-25. "ADDITIONAL SERVICE WHEN REPLACING CONTROL UNIT : Special Repair Requirement"](#).

>> GO TO 2.

2. CHECK ANTI-PINCH OPERATION

Check the anti-pinch operation.

Refer to [RF-25. "ADDITIONAL SERVICE WHEN REPLACING CONTROL UNIT : Special Repair Requirement"](#).

Is the inspection result normal?

YES >> Inspection End.

NO >> Check fitting adjustment. Refer to [RF-51. "Inspection"](#).

SUNSHADE MOTOR ASSEMBLY

SUNSHADE MOTOR ASSEMBLY : Description

INFOID:000000008511401

- BCM supplies the sunshade motor assembly with power.
- CPU is integrated in sunshade motor assembly.
- Slide open/close controlled by the sunshade switch operation.

SUNSHADE MOTOR ASSEMBLY : Component Function Check

INFOID:000000008511402

1. CHECK SUNSHADE MOTOR FUNCTION

Does the slide open and close functions operate normally with the sunshade switch?

Is the inspection result normal?

YES >> Sunshade motor assembly is OK.

NO >> Refer to [RF-30. "SUNSHADE MOTOR ASSEMBLY : Diagnosis Procedure"](#).

SUNSHADE MOTOR ASSEMBLY : Diagnosis Procedure

INFOID:000000008511403

Regarding Wiring Diagram information, refer to [RF-16. "Wiring Diagram"](#).

1. CHECK POWER SUPPLY

1. Turn ignition switch OFF.
2. Disconnect sunshade motor assembly connector.
3. Turn ignition switch ON.
4. Check voltage between sunshade motor assembly harness connector and ground.

(+)		(-)	Voltage (Approx.)
Sunshade motor assembly			
Connector	Terminal		
B85	10	Ground	Battery voltage

Is the inspection result normal?

YES >> GO TO 2.

NO >> GO TO 3.

2. CHECK GROUND CIRCUIT

1. Turn ignition switch OFF.
2. Check continuity between sunshade motor assembly harness connector and ground.

Sunshade motor assembly		Ground	Continuity
Connector	Terminal		
B85	8		Yes

POWER SUPPLY AND GROUND CIRCUIT

< DTC/CIRCUIT DIAGNOSIS >

Is the inspection result normal?

- YES >> GO TO 4.
- NO >> Repair or replace the harness.

3.CHECK SUNSHADE MOTOR CIRCUIT

1. Turn ignition switch OFF.
2. Disconnect BCM connector.
3. Check continuity between BCM harness connector and ground.

BCM		Ground	Continuity
Connector	Terminal		
M81	140		No

Is the inspection result normal?

- YES >> Replace BCM. Refer to [BCS-78. "Removal and Installation"](#).
- NO >> Repair or replace the harness.

4.CHECK INTERMITTENT INCIDENT

Refer to [GI-49. "Intermittent Incident"](#).

>> Inspection End.

A
B
C
D
E
F
G
H
I
J
RF
L
M
N
O
P

MOONROOF SWITCH

< DTC/CIRCUIT DIAGNOSIS >

MOONROOF SWITCH

Description

INFOID:000000008511404

Transmits switch operation signal to moonroof motor assembly.

Diagnosis Procedure

INFOID:000000008511405

Regarding Wiring Diagram information, refer to [RF-16, "Wiring Diagram"](#).

1. CHECK MOONROOF SWITCH INPUT SIGNAL

1. Turn ignition switch ON.
2. Check voltage between moonroof motor assembly harness connector and ground.

(+)		(-)	Condition	Voltage (Approx.)
Moonroof motor assembly				
Connector	Terminals			
R4	5	Ground	Moonroof switch is operated OPEN (1st)	0
			Other than above	Battery voltage
	1		Moonroof switch is operated CLOSE (2nd)	0
			Other than above	Battery voltage

Is the inspection result normal?

YES >> Inspection End.

NO >> GO TO 2.

2. CHECK MOONROOF SWITCH CIRCUIT

1. Turn ignition switch OFF.
2. Disconnect moonroof motor assembly connector and moonroof switch connector.
3. Check continuity between moonroof motor assembly harness connector and moonroof switch harness connector.

Moonroof motor assembly		Moonroof switch		Continuity
Connector	Terminal	Connector	Terminal	
R4	1	R108	10	Yes
	5		3	

4. Check continuity between moonroof motor assembly harness connector and ground.

Moonroof motor assembly		Ground	Continuity
Connector	Terminal		
R4	1		No
	5		

Is the inspection result normal?

YES >> GO TO 3.

NO >> Repair or replace the harness.

3. CHECK MOONROOF SWITCH GROUND CIRCUIT

Check continuity between moonroof switch harness connector and ground.

MOONROOF SWITCH

< DTC/CIRCUIT DIAGNOSIS >

Moonroof switch		Ground	Continuity
Connector	Terminal		
R108	6		Yes

Is the inspection result normal?

- YES >> GO TO 4.
 NO >> Repair or replace the harness.

4.CHECK MOONROOF SWITCH

Check moonroof switch.

Refer to [RF-33, "Component Inspection"](#).

Is the inspection result normal?

- YES >> GO TO 5.
 NO >> Replace moonroof switch. Refer to [RF-61, "Removal and Installation"](#).

5.CHECK INTERMITTENT INCIDENT

Refer to [GI-49, "Intermittent Incident"](#).

>> Inspection End.

Component Inspection

INFOID:000000008511406

MOONROOF SWITCH

1. CHECK MOONROOF SWITCH

1. Turn ignition switch OFF.
2. Disconnect moonroof switch.
3. Check continuity between moonroof switch terminals.

Terminals	Condition	Continuity
3	Moonroof switch is operated TILT DOWN or SLIDE OPEN OPEN	Yes
	Other than above	No
10	Moonroof switch is operated TILT UP or SLIDE CLOSE CLOSE	Yes
	Other than above	No

Is the inspection result normal?

- YES >> Moonroof switch is OK.
 NO >> Replace moonroof switch. Refer to [RF-61, "Removal and Installation"](#).

SUNSHADE SWITCH

< DTC/CIRCUIT DIAGNOSIS >

SUNSHADE SWITCH

Description

INFOID:000000008511407

Transmits switch operation signal to sunshade motor assembly.

Diagnosis Procedure

INFOID:000000008511408

Regarding Wiring Diagram information, refer to [RF-16, "Wiring Diagram"](#).

1. CHECK SUNSHADE SWITCH INPUT SIGNAL

1. Turn ignition switch ON.
2. Check voltage between sunshade motor assembly harness connector and ground.

(+)		(-)	Condition	Voltage (Approx.)
Sunshade motor assembly				
Connector	Terminals			
B85	6	Ground	Sunshade switch is operated OPEN (1st)	0
			Other than above	Battery voltage
	2		Sunshade switch is operated CLOSE (2nd)	0
			Other than above	Battery voltage

Is the inspection result normal?

YES >> Inspection End.

NO >> GO TO 2.

2. CHECK SUNSHADE SWITCH CIRCUIT

1. Turn ignition switch OFF.
2. Disconnect sunshade motor assembly connector and sunshade switch connector.
3. Check continuity between sunshade motor assembly harness connector and sunshade switch harness connector.

Sunshade motor assembly		Sunshade switch		Continuity
Connector	Terminal	Connector	Terminal	
B85	2	R110	3	Yes
	6		1	

4. Check continuity between sunshade motor assembly harness connector and ground.

Sunshade motor assembly		Ground	Continuity
Connector	Terminal		
B85	2		No
	6		

Is the inspection result normal?

YES >> GO TO 3.

NO >> Repair or the replace harness.

3. CHECK SUNSHADE SWITCH GROUND CIRCUIT

Check continuity between sunshade switch harness connector and ground.

SUNSHADE SWITCH

< DTC/CIRCUIT DIAGNOSIS >

Sunshade switch		Ground	Continuity
Connector	Terminal		
R110	2		Yes

Is the inspection result normal?

- YES >> GO TO 4.
 NO >> Repair or replace the harness.

4. CHECK SUNSHADE SWITCH

Check sunshade switch.

Refer to [RF-35. "Component Inspection"](#).

Is the inspection result normal?

- YES >> GO TO 5.
 NO >> Replace sunshade switch. Refer to [RF-62. "Removal and Installation"](#).

5. CHECK INTERMITTENT INCIDENT

Refer to [GI-49. "Intermittent Incident"](#).

>> Inspection End.

Component Inspection

INFOID:000000008511409

SUNSHADE SWITCH

1. CHECK SUNSHADE SWITCH

1. Turn ignition switch OFF.
2. Disconnect sunshade switch.
3. Check continuity between sunshade switch terminals.

Terminals		Condition	Continuity
1	2	Sunshade switch is operated OPEN	Yes
		Other than above	No
3		Sunshade switch is operated CLOSE	Yes
		Other than above	No

Is the inspection result normal?

- YES >> Sunshade switch is OK.
 NO >> Replace sunshade switch. Refer to [RF-62. "Removal and Installation"](#).

DOOR SWITCH

< DTC/CIRCUIT DIAGNOSIS >

DOOR SWITCH

Diagnosis Procedure

INFOID:000000008934186

Regarding Wiring Diagram information, refer to [DLK-72. "Wiring Diagram"](#).

1. CHECK DOOR SWITCH INPUT SIGNAL

1. Turn ignition switch OFF.
2. Disconnect malfunctioning door switch connector.
3. Check signal between malfunctioning door switch harness connector and ground using oscilloscope.

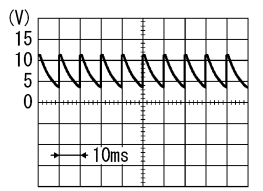
(+)		Terminal	(-)	Signal (Reference value)
Door switch				
Connector				
Driver side	B8	3	Ground	 <p>7.0 - 8.0 V</p>
Passenger side	B108			
Rear LH	B18			
Rear RH	B116			

Is the inspection result normal?

- YES >> GO TO 3.
NO >> GO TO 2.

2. CHECK DOOR SWITCH CIRCUIT

1. Disconnect BCM connector.
2. Check continuity between door switch harness connector and BCM harness connector.

Door switch		Terminal	BCM		Continuity
Connector			Connector	Terminal	
Driver side	B8	3	M20	96	Yes
Passenger side	B108			94	
Rear LH	B18			82	
Rear RH	B116			93	

3. Check continuity between door switch harness connector and ground.

Door switch		Terminal	Ground	Continuity
Connector				
Driver side	B8	3	Ground	No
Passenger side	B108			
Rear LH	B18			
Rear RH	B116			

Is the inspection result normal?

- YES >> Replace BCM. Refer to [BCS-78. "Removal and Installation"](#).
NO >> Repair or replace harness.

3. CHECK DOOR SWITCH

Refer to [DLK-169. "Component Inspection"](#).

DOOR SWITCH

< DTC/CIRCUIT DIAGNOSIS >

Is the inspection result normal?

YES >> GO TO 4.

NO >> Replace malfunctioning door switch. Refer to [DLK-310. "Removal and Installation"](#).

4.CHECK INTERMITTENT INCIDENT

Refer to [GI-49. "Intermittent Incident"](#).

>> Inspection End.

A

B

C

D

E

F

G

H

I

J

RF

L

M

N

O

P

MOONROOF DOES NOT OPERATE PROPERLY

< SYMPTOM DIAGNOSIS >

SYMPTOM DIAGNOSIS

MOONROOF DOES NOT OPERATE PROPERLY

Diagnosis Procedure

INFOID:000000008511411

1. CHECK BCM POWER SUPPLY AND GROUND CIRCUIT

Check BCM power supply and ground circuit.
Refer to [BCS-72, "Diagnosis Procedure"](#).

Is the inspection result normal?

- YES >> GO TO 2.
- NO >> Repair or replace malfunctioning parts.

2. CHECK MOONROOF MOTOR ASSEMBLY POWER SUPPLY AND GROUND CIRCUIT

Check moonroof motor assembly power supply and ground circuit.
Refer to [RF-27, "MOONROOF MOTOR ASSEMBLY : Component Function Check"](#).

Is the inspection result normal?

- YES >> Check intermittent incident. Refer to [GI-49, "Intermittent Incident"](#).
- NO >> Repair or replace malfunctioning parts.

SUNSHADE SYSTEM DOES NOT OPERATE PROPERLY

< SYMPTOM DIAGNOSIS >

SUNSHADE SYSTEM DOES NOT OPERATE PROPERLY

Diagnosis Procedure

INFOID:000000008511412

1.CHECK BCM POWER SUPPLY AND GROUND CIRCUIT

Check BCM power supply and ground circuit.
Refer to [BCS-72. "Diagnosis Procedure"](#).

Is the inspection result normal?

YES >> GO TO 2.

NO >> Repair or replace the malfunctioning parts.

2.CHECK SUNSHADE MOTOR ASSEMBLY POWER SUPPLY AND GROUND CIRCUIT

Check sunshade motor assembly power supply and ground circuit.
Refer to [RF-30. "SUNSHADE MOTOR ASSEMBLY : Diagnosis Procedure"](#).

Is the inspection result normal?

YES >> GO TO 3.

NO >> Repair or replace the malfunctioning parts.

3.CONFIRM THE OPERATION

Confirm the operation again.

Is the result normal?

YES >> Check intermittent incident. Refer to [GI-49. "Intermittent Incident"](#).

NO >> GO TO 1.

A
B
C
D
E
F
G
H
I
J
RF
L
M
N
O
P

AUTO OPERATION DOES NOT OPERATE

< SYMPTOM DIAGNOSIS >

AUTO OPERATION DOES NOT OPERATE MOONROOF

MOONROOF : Diagnosis Procedure

INFOID:000000008511413

1. PERFORM INITIALIZATION PROCEDURE

Perform initialization procedure.

Refer to [RF-25, "ADDITIONAL SERVICE WHEN REPLACING CONTROL UNIT : Special Repair Requirement"](#).

Is the inspection result normal?

YES >> Moonroof system is normal.

NO >> GO TO 2.

2. CHECK MOONROOF SWITCH

Check moonroof switch.

Refer to [RF-32, "Diagnosis Procedure"](#).

Is the inspection result normal?

YES >> GO TO 3.

NO >> Repair or replace the malfunctioning parts.

3. CONFIRM THE OPERATION

Confirm the operation again.

Is the inspection result normal?

YES >> Check intermittent incident. Refer to [GI-49, "Intermittent Incident"](#).

NO >> GO TO 1.

SUNSHADE

SUNSHADE : Diagnosis Procedure

INFOID:000000008511414

1. PERFORM INITIALIZATION PROCEDURE

Refer to [RF-25, "ADDITIONAL SERVICE WHEN REPLACING CONTROL UNIT : Special Repair Requirement"](#).

Is the inspection result normal?

YES >> Sunshade system is normal.

NO >> GO TO 2.

2. CHECK SUNSHADE SWITCH

Check sunshade switch.

Refer to [RF-34, "Diagnosis Procedure"](#).

Is the inspection result normal?

YES >> GO TO 3.

NO >> Repair or replace the malfunctioning parts.

3. CONFIRM THE OPERATION

Confirm the operation again.

Is the result normal?

YES >> Check intermittent incident. Refer to [GI-49, "Intermittent Incident"](#).

NO >> GO TO 1.

ANTI-PINCH FUNCTION DOES NOT OPERATE

< SYMPTOM DIAGNOSIS >

ANTI-PINCH FUNCTION DOES NOT OPERATE MOONROOF

MOONROOF : Diagnosis Procedure

INFOID:000000008511415

1. PERFORM INITIALIZATION PROCEDURE

Perform initialization procedure.

Refer to [RF-25, "ADDITIONAL SERVICE WHEN REPLACING CONTROL UNIT : Special Repair Requirement"](#).

Is the inspection result normal?

YES >> GO TO 2.

NO >> Perform basic inspection. Refer to [RF-23, "Work Flow"](#).

2. RETEST THE ANTI-PINCH FUNCTION

Check anti-pinch operation. Refer to [RF-25, "ADDITIONAL SERVICE WHEN REPLACING CONTROL UNIT : Special Repair Requirement"](#).

Is the inspection result normal?

YES >> Inspection End.

NO >> Replace the moonroof motor assembly. Refer to [RF-50, "Removal and Installation"](#).

SUNSHADE

SUNSHADE : Diagnosis Procedure

INFOID:000000008511416

1. CHECK SUNSHADE MECHANISM

Check the following:

- Operation malfunction caused by sunshade mechanism deformation, pinched harness or other foreign materials
- Operation malfunction and interference with other parts by poor installation

Is the inspection result normal?

YES >> GO TO 2.

NO >> Repair or replace the malfunctioning parts.

2. PERFORM INITIALIZATION PROCEDURE

Perform anti-pinch procedure.

Refer to [RF-25, "ADDITIONAL SERVICE WHEN REPLACING CONTROL UNIT : Special Repair Requirement"](#).

Is the inspection result normal?

YES >> GO TO 3.

NO >> GO TO 1.

3. RETEST THE ANTI-PINCH FUNCTION

Check anti-pinch operation. Refer to [RF-25, "ADDITIONAL SERVICE WHEN REPLACING CONTROL UNIT : Special Repair Requirement"](#).

Is the inspection result normal?

YES >> Inspection End.

NO >> Replace the sunshade motor assembly. Refer to [RF-59, "REAR SUNSHADE UNIT : Removal and Installation"](#).

A
B
C
D
E
F
G
H
I
J
RF
L
M
N
O
P

RETAINED POWER OPERATION DOES NOT OPERATE PROPERLY

< SYMPTOM DIAGNOSIS >

RETAINED POWER OPERATION DOES NOT OPERATE PROPERLY

Diagnosis Procedure

INFOID:000000008511417

1. CHECK FRONT DOOR SWITCH

Check (LH and RH) front door switches.

Refer to [DLK-168. "Diagnosis Procedure"](#).

Is the inspection result normal?

YES >> GO TO 2.

NO >> Repair or replace the malfunctioning parts.

2. CONFIRM THE OPERATION

Confirm the operation again.

Is the inspection result normal?

YES >> Check intermittent incident. Refer to [GI-49. "Intermittent Incident"](#).

NO >> GO TO 1.

SQUEAK AND RATTLE TROUBLE DIAGNOSES

< SYMPTOM DIAGNOSIS >

SQUEAK AND RATTLE TROUBLE DIAGNOSES

Work Flow

INFOID:000000008966030

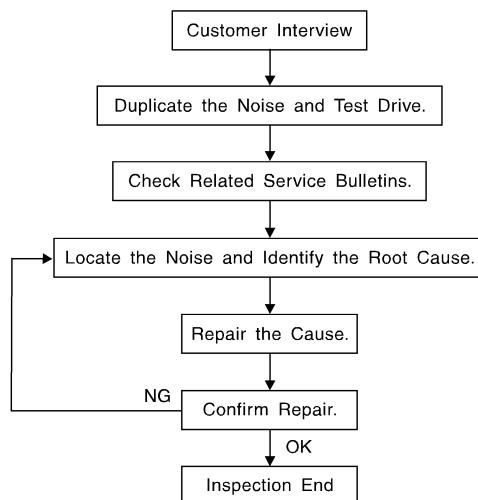

SBT842

CUSTOMER INTERVIEW

Interview the customer if possible, to determine the conditions that exist when the noise occurs. Use the Diagnostic Worksheet during the interview to document the facts and conditions when the noise occurs and any customer's comments; refer to [RF-47, "Diagnostic Worksheet"](#). This information is necessary to duplicate the conditions that exist when the noise occurs.

- The customer may not be able to provide a detailed description or the location of the noise. Attempt to obtain all the facts and conditions that exist when the noise occurs (or does not occur).
- If there is more than one noise in the vehicle, be sure to diagnose and repair the noise that the customer is concerned about. This can be accomplished by test driving the vehicle with the customer.
- After identifying the type of noise, isolate the noise in terms of its characteristics. The noise characteristics are provided so the customer, service adviser and technician are all speaking the same language when defining the noise.
- Squeak —(Like tennis shoes on a clean floor)
Squeak characteristics include the light contact/fast movement/brought on by road conditions/hard surfaces = higher pitch noise/softer surfaces = lower pitch noises/edge to surface = chirping.
- Creak—(Like walking on an old wooden floor)
Creak characteristics include firm contact/slow movement/twisting with a rotational movement/pitch dependent on materials/often brought on by activity.
- Rattle—(Like shaking a baby rattle)
Rattle characteristics include the fast repeated contact/vibration or similar movement/loose parts/missing clip or fastener/incorrect clearance.
- Knock —(Like a knock on a door)
Knock characteristics include hollow sounding/sometimes repeating/often brought on by driver action.
- Tick—(Like a clock second hand)
Tick characteristics include gentle contacting of light materials/loose components/can be caused by driver action or road conditions.
- Thump—(Heavy, muffled knock noise)
Thump characteristics include softer knock/dead sound often brought on by activity.
- Buzz—(Like a bumble bee)
Buzz characteristics include high frequency rattle/firm contact.
- Often the degree of acceptable noise level will vary depending upon the person. A noise that you may judge as acceptable may be very irritating to the customer.
- Weather conditions, especially humidity and temperature, may have a great effect on noise level.

DUPLICATE THE NOISE AND TEST DRIVE

If possible, drive the vehicle with the customer until the noise is duplicated. Note any additional information on the Diagnostic Worksheet regarding the conditions or location of the noise. This information can be used to duplicate the same conditions when you confirm the repair.

SQUEAK AND RATTLE TROUBLE DIAGNOSES

< SYMPTOM DIAGNOSIS >

If the noise can be duplicated easily during the test drive, to help identify the source of the noise, try to duplicate the noise with the vehicle stopped by doing one or all of the following:

- 1) Close a door.
 - 2) Tap or push/pull around the area where the noise appears to be coming from.
 - 3) Rev the engine.
 - 4) Use a floor jack to recreate vehicle "twist".
 - 5) At idle, apply engine load (electrical load, half-clutch on M/T model, drive position on CVT and A/T models).
 - 6) Raise the vehicle on a hoist and hit a tire with a rubber hammer.
- Drive the vehicle and attempt to duplicate the conditions the customer states exist when the noise occurs.
 - If it is difficult to duplicate the noise, drive the vehicle slowly on an undulating or rough road to stress the vehicle body.

CHECK RELATED SERVICE BULLETINS

After verifying the customer concern or symptom, check ASIST for Technical Service Bulletins (TSBs) related to that concern or symptom.

If a TSB relates to the symptom, follow the procedure to repair the noise.

LOCATE THE NOISE AND IDENTIFY THE ROOT CAUSE

1. Narrow down the noise to a general area. To help pinpoint the source of the noise, use a listening tool (Chassis Ear: J-39570, Engine Ear: J-39565 and mechanic's stethoscope).
2. Narrow down the noise to a more specific area and identify the cause of the noise by:
 - removing the components in the area that you suspect the noise is coming from.
Do not use too much force when removing clips and fasteners, otherwise clips and fasteners can be broken or lost during the repair, resulting in the creation of new noise.
 - tapping or pushing/pulling the component that you suspect is causing the noise.
Do not tap or push/pull the component with excessive force, otherwise the noise will be eliminated only temporarily.
 - feeling for a vibration with your hand by touching the component(s) that you suspect is (are) causing the noise.
 - placing a piece of paper between components that you suspect are causing the noise.
 - looking for loose components and contact marks.Refer to [RF-45. "Generic Squeak and Rattle Troubleshooting"](#).

REPAIR THE CAUSE

- If the cause is a loose component, tighten the component securely.
- If the cause is insufficient clearance between components:
 - separate components by repositioning or loosening and retightening the component, if possible.
 - insulate components with a suitable insulator such as urethane pads, foam blocks, felt cloth tape or urethane tape. A NISSAN Squeak and Rattle Kit (J-43980) is available through your authorized NISSAN Parts Department.

CAUTION:

Do not use excessive force as many components are constructed of plastic and may be damaged.

Always check with the Parts Department for the latest parts information.

The following materials are contained in the NISSAN Squeak and Rattle Kit (J-43980). Each item can be ordered separately as needed.

URETHANE PADS [1.5 mm (0.059 in) thick]

Insulates connectors, harness, etc.

76268-9E005: 100×135 mm (3.94×5.31 in)/76884-71L01: 60×85 mm (2.36×3.35 in)/76884-71L02: 15×25 mm (0.59×0.98 in)

INSULATOR (Foam blocks)

Insulates components from contact. Can be used to fill space behind a panel.

73982-9E000: 45 mm (1.77 in) thick, 50×50 mm (1.97×1.97 in)/73982-50Y00: 10 mm (0.39 in) thick, 50×50 mm (1.97×1.97 in)

INSULATOR (Light foam block)

80845-71L00: 30 mm (1.18 in) thick, 30×50 mm (1.18×1.97 in)

FELT CLOTH TAPE

Used to insulate where movement does not occur. Ideal for instrument panel applications.

68370-4B000: 15×25 mm (0.59×0.98 in) pad/68239-13E00: 5 mm (0.20 in) wide tape roll. The following materials not found in the kit can also be used to repair squeaks and rattles.

UHMW (TEFLON) TAPE

Insulates where slight movement is present. Ideal for instrument panel applications.

SILICONE GREASE

SQUEAK AND RATTLE TROUBLE DIAGNOSES

< SYMPTOM DIAGNOSIS >

Used instead of UHMW tape that will be visible or not fit.

Note: Will only last a few months.

SILICONE SPRAY

Use when grease cannot be applied.

DUCT TAPE

Use to eliminate movement.

CONFIRM THE REPAIR

Confirm that the cause of a noise is repaired by test driving the vehicle. Operate the vehicle under the same conditions as when the noise originally occurred. Refer to the notes on the Diagnostic Worksheet.

Generic Squeak and Rattle Troubleshooting

INFOID:000000008966031

Refer to Table of Contents for specific component removal and installation information.

INSTRUMENT PANEL

Most incidents are caused by contact and movement between:

1. Cluster lid A and the instrument panel
2. Acrylic lens and combination meter housing
3. Instrument panel to front pillar finisher
4. Instrument panel to windshield
5. Instrument panel pins
6. Wiring harnesses behind the combination meter
7. A/C defroster duct and duct joint

These incidents can usually be located by tapping or moving the components to duplicate the noise or by pressing on the components while driving to stop the noise. Most of these incidents can be repaired by applying felt cloth tape or silicone spray (in hard to reach areas). Urethane pads can be used to insulate wiring harness.

CAUTION:

Do not use silicone spray to isolate a squeak or rattle. If you saturate the area with silicone, you will not be able to recheck the repair.

CENTER CONSOLE

Components to pay attention to include:

1. Shift selector assembly cover to finisher
2. A/C control unit and cluster lid C
3. Wiring harnesses behind audio and A/C control unit

The instrument panel repair and isolation procedures also apply to the center console.

DOORS

Pay attention to the:

1. Finisher and inner panel making a slapping noise
2. Inside handle escutcheon to door finisher
3. Wiring harnesses tapping
4. Door striker out of alignment causing a popping noise on starts and stops

Tapping or moving the components or pressing on them while driving to duplicate the conditions can isolate many of these incidents. You can usually insulate the areas with felt cloth tape or insulator foam blocks from the NISSAN Squeak and Rattle Kit (J-43980) to repair the noise.

TRUNK

Trunk noises are often caused by a loose jack or loose items put into the trunk by the owner.

In addition look for:

1. Trunk lid bumpers out of adjustment
2. Trunk lid striker out of adjustment
3. The trunk lid torsion bars knocking together
4. A loose license plate or bracket

A

B

C

D

E

F

G

H

I

J

RF

L

M

N

O

P

SQUEAK AND RATTLE TROUBLE DIAGNOSES

< SYMPTOM DIAGNOSIS >

Most of these incidents can be repaired by adjusting, securing or insulating the item(s) or component(s) causing the noise.

SUNROOF/HEADLINING

Noises in the sunroof/headlining area can often be traced to one of the following:

1. Sunroof lid, rail, linkage or seals making a rattle or light knocking noise
2. Sun visor shaft shaking in the holder
3. Front or rear windshield touching headlining and squeaking

Again, pressing on the components to stop the noise while duplicating the conditions can isolate most of these incidents. Repairs usually consist of insulating with felt cloth tape.

OVERHEAD CONSOLE (FRONT AND REAR)

Overhead console noises are often caused by the console panel clips not being engaged correctly. Most of these incidents are repaired by pushing up on the console at the clip locations until the clips engage.

In addition look for:

1. Loose harness or harness connectors.
2. Front console map/reading lamp lens loose.
3. Loose screws at console attachment points.

SEATS

When isolating seat noise it's important to note the position the seat is in and the load placed on the seat when the noise is present. These conditions should be duplicated when verifying and isolating the cause of the noise.

Cause of seat noise include:

1. Headrest rods and holder
2. A squeak between the seat pad cushion and frame
3. The rear seatback lock and bracket

These noises can be isolated by moving or pressing on the suspected components while duplicating the conditions under which the noise occurs. Most of these incidents can be repaired by repositioning the component or applying urethane tape to the contact area.

UNDERHOOD

Some interior noise may be caused by components under the hood or on the engine wall. The noise is then transmitted into the passenger compartment.

Causes of transmitted underhood noise include:

1. Any component installed to the engine wall
2. Components that pass through the engine wall
3. Engine wall mounts and connectors
4. Loose radiator installation pins
5. Hood bumpers out of adjustment
6. Hood striker out of adjustment

These noises can be difficult to isolate since they cannot be reached from the interior of the vehicle. The best method is to secure, move or insulate one component at a time and test drive the vehicle. Also, engine rpm or load can be changed to isolate the noise. Repairs can usually be made by moving, adjusting, securing, or insulating the component causing the noise.

SQUEAK AND RATTLE TROUBLE DIAGNOSES

< SYMPTOM DIAGNOSIS >

Diagnostic Worksheet

INFOID:000000008966032

Dear Customer:

We are concerned about your satisfaction with your vehicle. Repairing a squeak or rattle sometimes can be very difficult. To help us fix your vehicle right the first time, please take a moment to note the area of the vehicle where the squeak or rattle occurs and under what conditions. You may be asked to take a test drive with a service advisor or technician to ensure we confirm the noise you are hearing.

SQUEAK & RATTLE DIAGNOSTIC WORKSHEET

I. WHERE DOES THE NOISE COME FROM? (circle the area of the vehicle)

The illustrations are for reference only, and may not reflect the actual configuration of your vehicle.

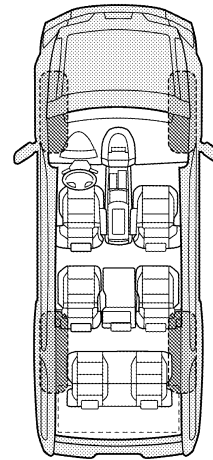
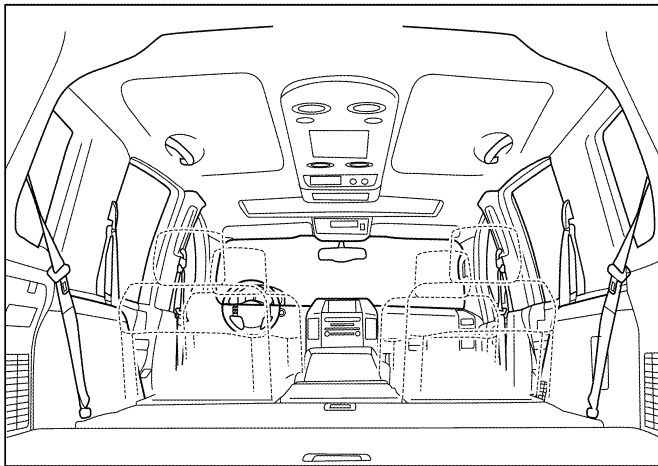
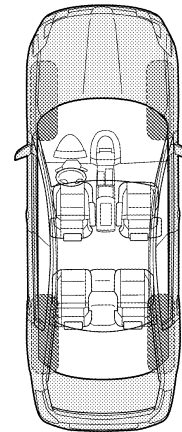
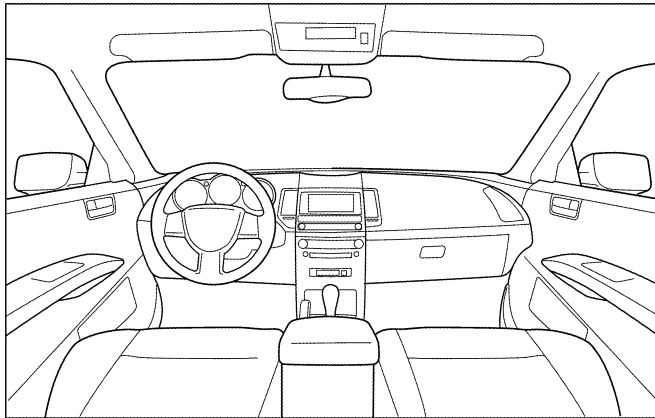

Continue to page 2 of the worksheet and briefly describe the location of the noise or rattle. In addition, please indicate the conditions which are present when the noise occurs.

A
B
C
D
E
F
G
H
I
J
RF
L
M
N
O
P

SQUEAK AND RATTLE TROUBLE DIAGNOSES

< SYMPTOM DIAGNOSIS >

SQUEAK & RATTLE DIAGNOSTIC WORKSHEET - page 2

Briefly describe the location where the noise occurs:

II. WHEN DOES IT OCCUR? (please check the boxes that apply)

- | | |
|---|--|
| <input type="checkbox"/> Anytime | <input type="checkbox"/> After sitting out in the rain |
| <input type="checkbox"/> 1st time in the morning | <input type="checkbox"/> When it is raining or wet |
| <input type="checkbox"/> Only when it is cold outside | <input type="checkbox"/> Dry or dusty conditions |
| <input type="checkbox"/> Only when it is hot outside | <input type="checkbox"/> Other: |

III. WHEN DRIVING:

- Through driveways
- Over rough roads
- Over speed bumps
- Only about ____ mph
- On acceleration
- Coming to a stop
- On turns: left, right or either (circle)
- With passengers or cargo
- Other: _____
- After driving ____ miles or ____ minutes

IV. WHAT TYPE OF NOISE

- Squeak (like tennis shoes on a clean floor)
- Creak (like walking on an old wooden floor)
- Rattle (like shaking a baby rattle)
- Knock (like a knock at the door)
- Tick (like a clock second hand)
- Thump (heavy muffled knock noise)
- Buzz (like a bumble bee)

TO BE COMPLETED BY DEALERSHIP PERSONNEL

Test Drive Notes:

	YES	NO	Initials of person performing
Vehicle test driven with customer	<input type="checkbox"/>	<input type="checkbox"/>	_____
- Noise verified on test drive	<input type="checkbox"/>	<input type="checkbox"/>	_____
- Noise source located and repaired	<input type="checkbox"/>	<input type="checkbox"/>	_____
- Follow up test drive performed to confirm repair	<input type="checkbox"/>	<input type="checkbox"/>	_____

VIN: _____ Customer Name _____
W.O.# _____ Date: _____

This form must be attached to Work Order

LATA0071E

GLASS LID

< REMOVAL AND INSTALLATION >

REMOVAL AND INSTALLATION

GLASS LID

Removal and Installation

INFOID:000000008511421

CAUTION:

- After installing glass lid, check gap/height adjustments and operation to make sure there is no malfunction.
- Handle glass lid with care to prevent damage.

REMOVAL

1. Open sunshade (1) and close glass lid.
↳: Front
2. Slide the side trim covers (2) (LH/RH) inward, then release from the glass lid inside edge and set aside.
3. Remove the glass lid bolts (A) on the LH and RH sides.

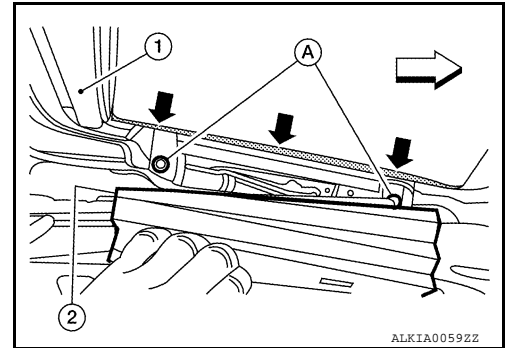

4. Remove glass lid from moonroof unit assembly.

INSTALLATION

1. Position glass lid to moonroof unit assembly.
2. Tighten glass lid bolts.

NOTE:

First tighten left front bolt, then right rear bolt on glass lid to prevent uneven torque while tightening remaining bolts.

3. Slide side trim covers onto inside edge of glass lid.
4. After installation, check moonroof operation and glass lid alignment. Refer to [RF-51, "Inspection"](#).

A
B
C
D
E
F
G
H
I
J
RF
L
M
N
O
P

MOONROOF MOTOR ASSEMBLY

< REMOVAL AND INSTALLATION >

MOONROOF MOTOR ASSEMBLY

Removal and Installation

INFOID:000000008511422

REMOVAL

1. Close glass lid.
2. Remove headlining. Refer to [INT-24, "Removal and Installation"](#).
3. Remove moonroof motor assembly screws (2).
↳: Front
4. Disconnect harness connector (A) and remove moonroof motor assembly (1) from moonroof unit assembly front end rail.

CAUTION:

Do not run the removed moonroof motor assembly as a single unit.

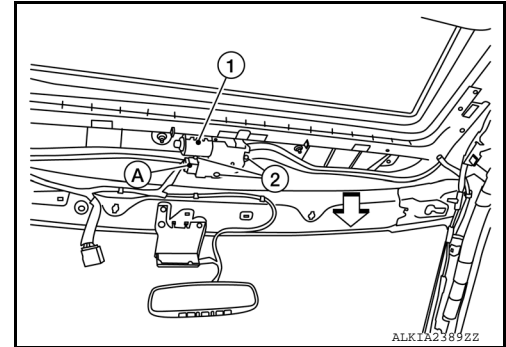

INSTALLATION

1. Move moonroof motor assembly laterally little by little so that the gear is completely engaged into the wire on the moonroof unit assembly, and the mounting surfaces become parallel. Install the moonroof motor assembly screws and tighten.

CAUTION:

Before installing the motor, be sure to place the link and wire assembly in the symmetrical and fully closed position.

NOTE:

If necessary, insert a suitable tool into the drive key and rotate right or left slightly to assist in complete moonroof motor gear alignment.

2. Remainder of installation is in the reverse order of removal.
3. Synchronize moonroof motor assembly with moonroof unit assembly. Refer to [RF-25, "ADDITIONAL SERVICE WHEN REPLACING CONTROL UNIT : Special Repair Requirement"](#).

MOONROOF UNIT ASSEMBLY

< REMOVAL AND INSTALLATION >

MOONROOF UNIT ASSEMBLY

Inspection

INFOID:000000008511423

WIND DEFLECTOR

1. Open glass lid fully.
2. Visually check for proper installation, damaged/deteriorated components, or foreign objects within mechanism. Correct as required for smooth operation.
3. Check for grease at the wind deflector arm (1) and pivot areas. If necessary, apply a sufficient amount of grease for non-binding operation.
↔: Front

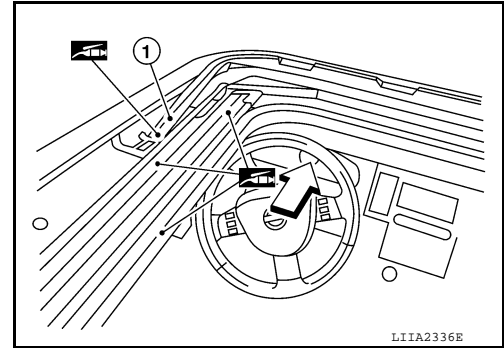

4. Check that the wind deflector (1) moves freely within the moonroof unit assembly while manually pressing down and releasing. If a malfunction is detected, remove the moonroof unit assembly and visually inspect. If damage is found, replace either wind deflector (1) or moonroof unit assembly as required. Refer to [RF-60. "Removal and Installation"](#) (WIND DEFLECTOR) or [RF-55. "Removal and Installation"](#) (MOONROOF UNIT ASSEMBLY).
↔: Front

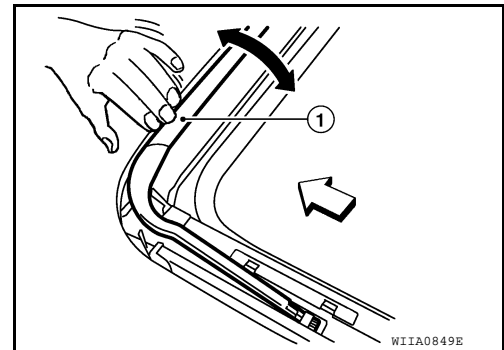

LINK AND WIRE ASSEMBLY

NOTE:

Before replacing a suspect part, make sure it is the source of noise being experienced.

1. Check link to determine if coating film has peeled off excessively enough that substrate is visible. Check also to determine if link is the source of noise. Replace as necessary.
2. Visually check to determine if a sufficient amount of grease has been applied to wire or rail groove. If not, add grease as required.
3. Check wire for any damage or deterioration. If any damage is found, replace moonroof unit assembly. Refer to [RF-55. "Removal and Installation"](#)

WEATHERSTRIP

1. Visually check weatherstrip for damage, deterioration, or deformation.
 - Open glass lid partially to inspect front edge of weatherstrip.
 - Tilt up glass lid fully to inspect sides and rear edge of weatherstrip.If any area of the weatherstrip is found to be damaged, replace the glass lid. Refer to [RF-49. "Removal and Installation"](#).
2. Check for leakage around glass lid.
 - Close glass lid.
 - Pour water around surface to determine area of concern.
 - For gaps or misalignment, adjust glass lid to specifications. Refer to ADJUSTMENT in this section.
 - For damaged sealing surfaces, either replace glass lid, refer to [RF-49. "Removal and Installation"](#) or repair the panel.

DRAIN HOSES

A
B
C
D
E
F
G
H
I
J

RF

L
M
N
O
P

MOONROOF UNIT ASSEMBLY

< REMOVAL AND INSTALLATION >

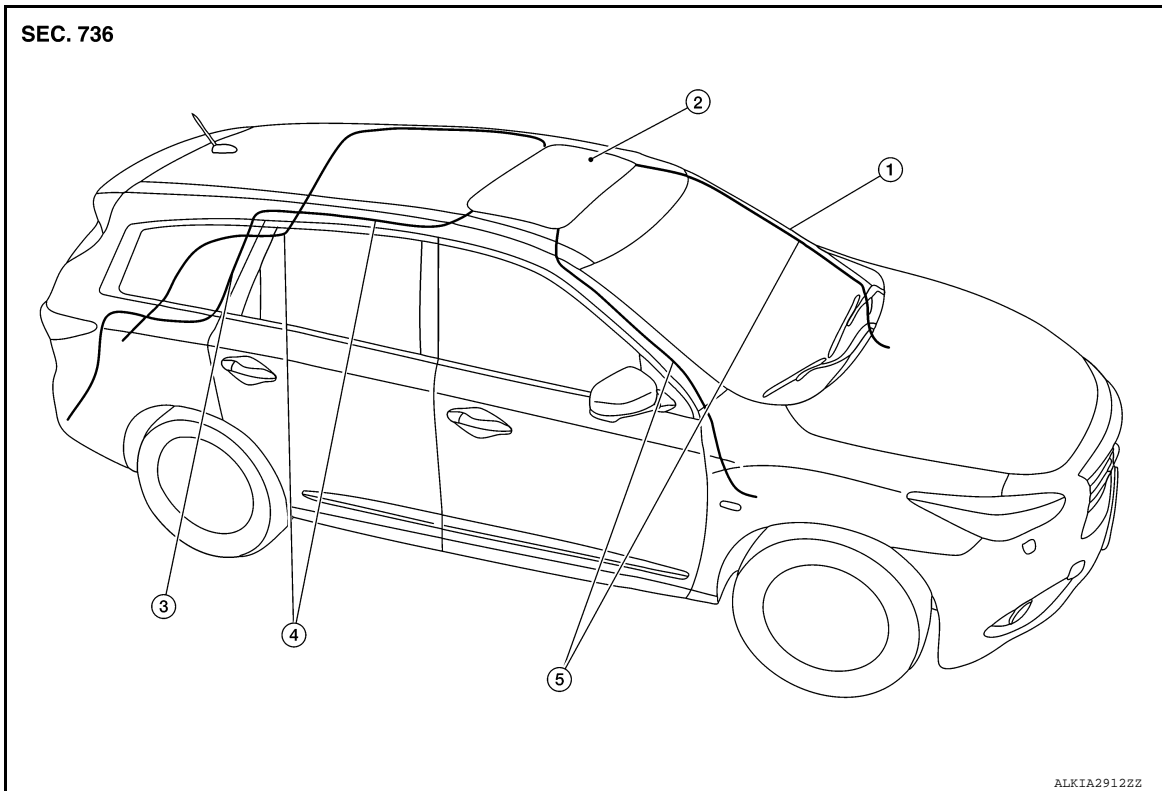

1. Front pillar
2. Moonroof unit assembly
3. Rear pillar
4. Drain hoses rear (LH/RH)
5. Drain hoses front (LH/RH)

1. Remove the headlining. Refer to [INT-24. "Removal and Installation"](#).
2. From the inside front pillar (4) visually check drain hoses (1) for:
 - Proper connection at moonroof unit assembly (3) and drain hose (1).
 - Damage, pinch, cracks, deterioration.
 - Proper fastening (2) and routing on body panels.

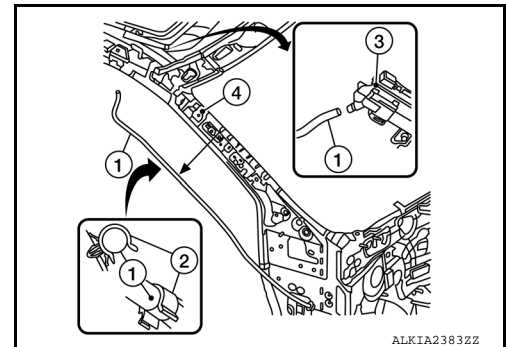

3. Pour water through drain hoses to determine watertight performance. If damaged or leaking portions in any drain hose is found, replace entire drain hose as necessary.
4. From the inside of the rear quarter panel (3) visually check drain hoses (2) for damage, pinching, cracks, or deterioration.
5. Check for proper connection at moonroof unit assembly (4) and drain hose (2) and for proper routing along the rear side glass (1) and the rear inner quarter panel (3).

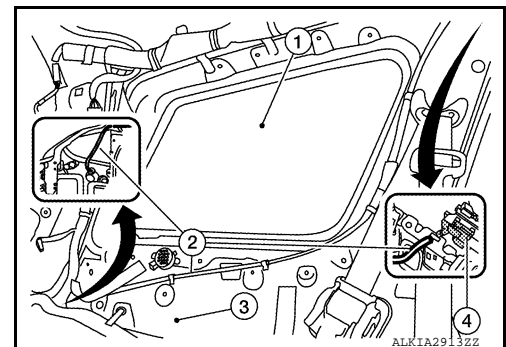

ADJUSTMENT

CAUTION:

MOONROOF UNIT ASSEMBLY

< REMOVAL AND INSTALLATION >

- Always work with a helper.
- Handle glass lid with care to prevent damage.

NOTE:

- For easier and more accurate installation, always mark each point before removal.
- After any adjustment, check moonroof operation and glass lid alignment.

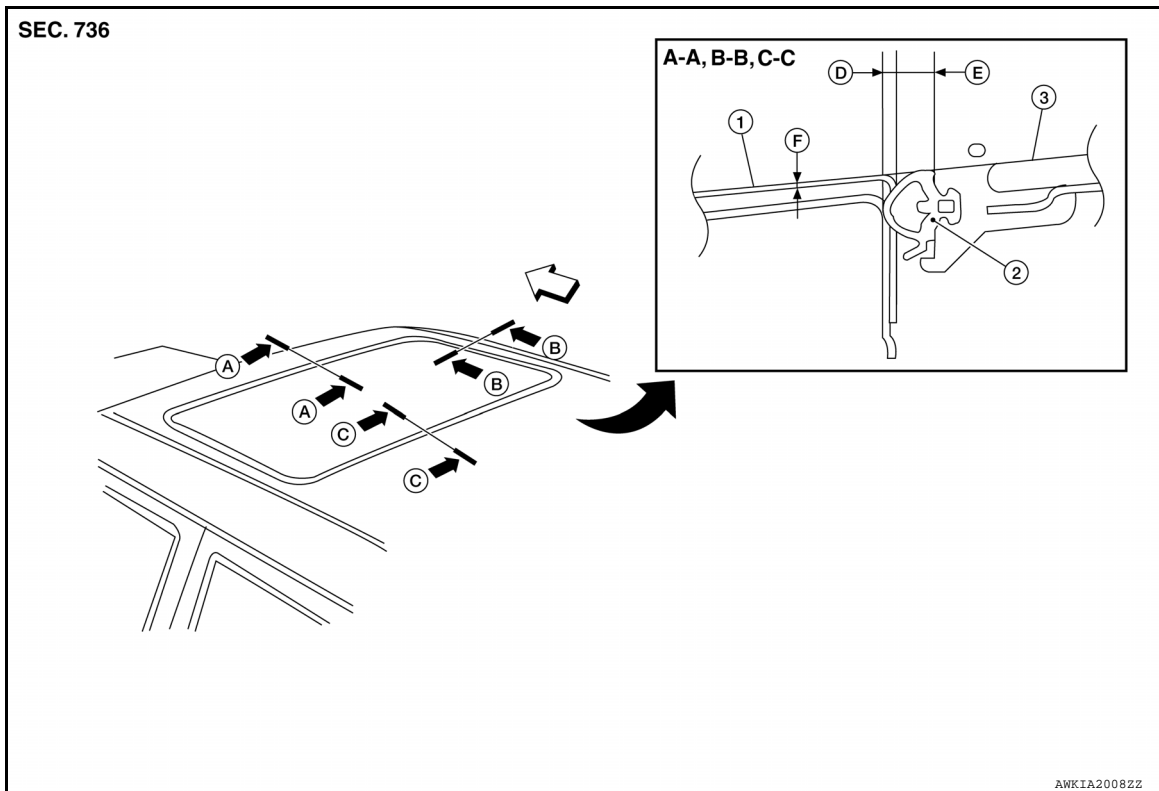

1. Roof panel

2. Weatherstrip

3. Glass lid

⇐ Front

Portion	Gap		Surface
	D	E	F
A-A	1.4 ± 0.9 (0.06 ± 0.04)	$5.4 \pm (0.21)$	-0.8 ± 1.5 (-0.03 ± 0.06)
B-B	1.4 ± 0.09 (0.06 ± 0.04)	$5.8 \pm (0.21)$	-0.8 ± 1.5 (-0.03 ± 0.06)
C-C	1.4 ± 0.09 (0.06 ± 0.04)	$5.8 \pm (0.21)$	-0.8 ± 1.5 (-0.03 ± 0.06)

Gap adjustment (Front and Rear)

1. Open sunshade (1).
⇐: Front
2. Tilt glass lid up, then release side trim cover (2) (LH/RH) and set aside.
NOTE:
LH side shown; RH similar.
3. Loosen glass lid bolts (A) (2 each on LH and RH side), then tilt glass lid down (⇐).
4. Manually adjust glass lid from outside of vehicle until gaps A-A and C-C are within specification.
NOTE:

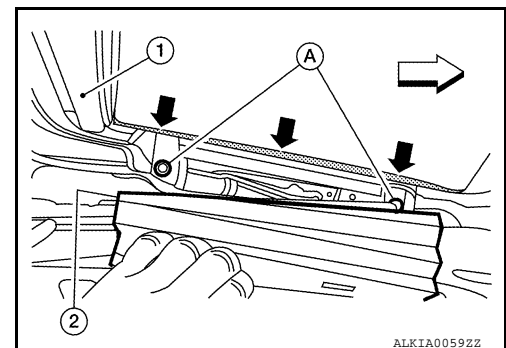

Temporarily loosely tighten glass lid, with assembly bolts to prevent movement between each adjustment.

5. Tilt glass lid up and down several times using moonroof switch to check that it operates smoothly.
6. Tilt glass lid up and tighten bolts.

A
B
C
D
E
F
G
H
I
J

RF

L
M

N
O
P

MOONROOF UNIT ASSEMBLY

< REMOVAL AND INSTALLATION >

NOTE:

First tighten left front bolt, then right rear bolt on glass lid to prevent uneven torque while tightening remaining bolts.

7. Attach side trim covers (LH/RH), then tilt glass lid down.

Gap Adjustment (Sides)

The moonroof unit is mounted on locator pins and adjustment from side to side cannot be performed.

Surface Height Adjustment

1. Tilt glass lid up and down several times using moonroof switch to check that it operates smoothly.
2. Check height difference between roof surface and glass lid surface, then compare to specifications.
3. If necessary, adjust height difference by using the following procedure.
 - Loosen glass lid bolts.
 - Manually raise/lower glass lid until height difference is within specification.

NOTE:

If necessary, shims may be added between moonroof unit assembly and roof to increase adjustment range. Refer to [RF-55, "Removal and Installation"](#).

Temporarily loosely tighten moonroof unit assembly bolts to prevent movement between each adjustment.

- Tilt glass lid up and down several times using moonroof switch to check that it operates smoothly.
- Tighten glass lid and moonroof side bracket bolts.

NOTE:

First tighten left front bolt, then right rear bolt on glass lid to prevent uneven torque while tightening remaining bolts.

- After any adjustment, check moonroof operation and glass lid alignment.

MOONROOF UNIT ASSEMBLY

< REMOVAL AND INSTALLATION >

Exploded View

INFOID:000000008511424

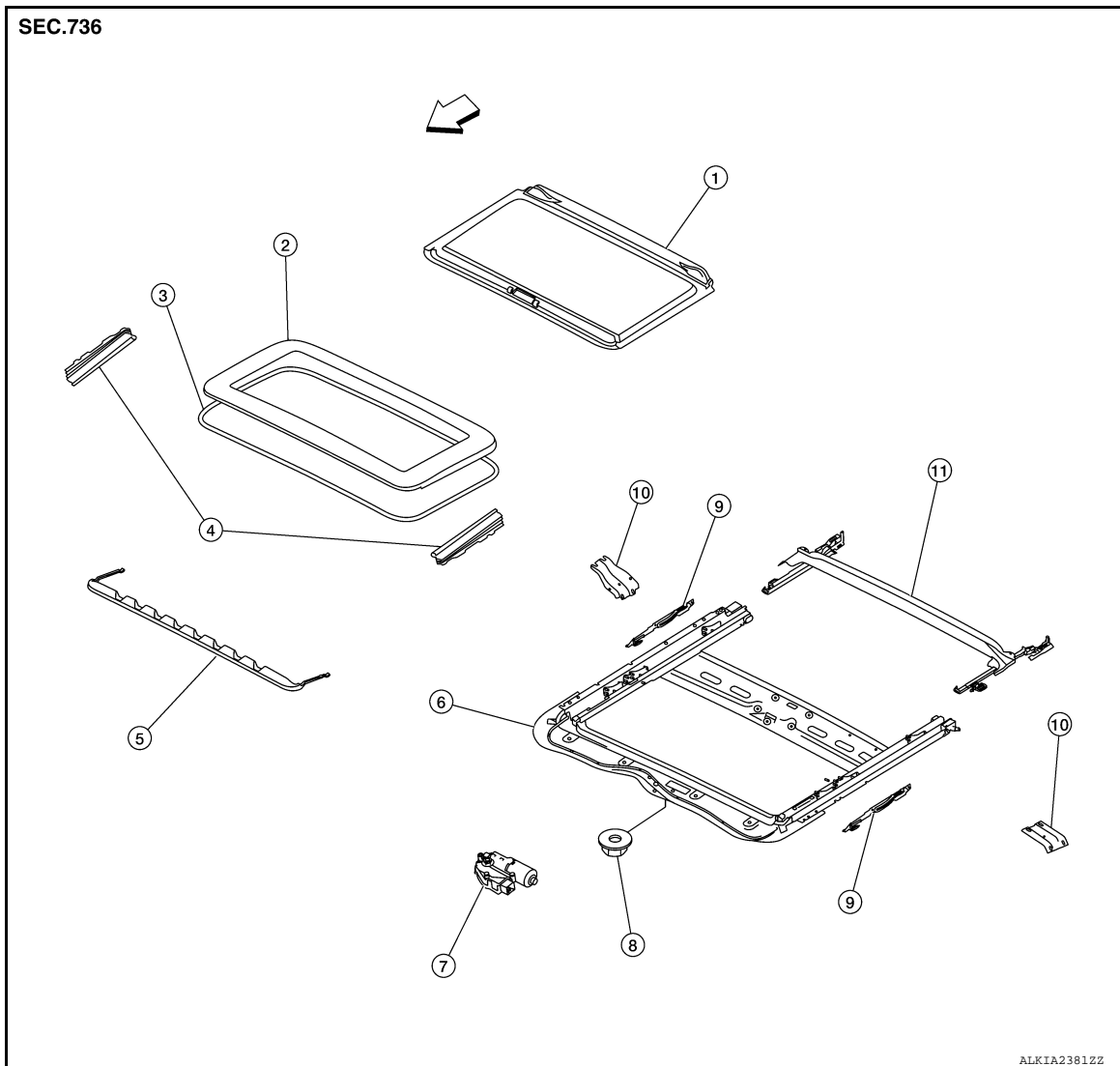

- | | | |
|----------------------------|-------------------|---------------------------|
| 1. Sunshade | 2. Glass lid | 3. Weatherstrip |
| 4. Side trim cover (LH/RH) | 5. Wind deflector | 6. Moonroof unit assembly |
| 7. Moonroof motor assembly | 8. Nut | 9. Lift arm |
| 10. Moonroof side brackets | 11. Cross support | ⇐ Front |

Removal and Installation

INFOID:000000008511425

CAUTION:

- After installing either moonroof unit assembly or glass lid, check gap/height adjustments and operation to make sure there is no malfunction.
- Always work with a helper.
- Handle glass lid assembly with care to prevent damage.
- When taking moonroof unit out, use shop cloths to protect the seats and trim from damage.

REMOVAL

1. Close glass lid.
2. Remove the headlining. Refer to [INT-24, "Removal and Installation"](#).
3. Disconnect drain hoses.
4. Disconnect the harness connector from moonroof motor assembly.

A
B
C
D
E
F
G
H
I
J
RF
L
M
N
O
P

MOONROOF UNIT ASSEMBLY

< REMOVAL AND INSTALLATION >

5. Remove nuts (A) from the remaining studs (1).

NOTE:

The guide pins (2) will help guide the moon roof assembly (4) down from the roof panel (3).

↔: Front

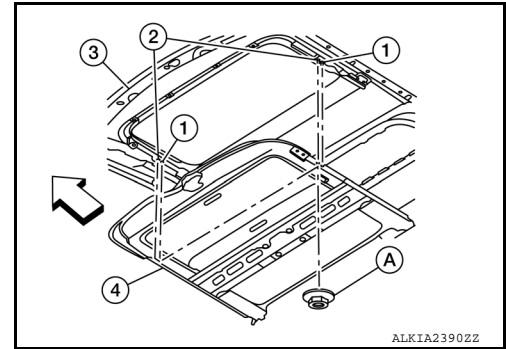

6. Remove bolts (↔) on the front end and side rails of the moonroof unit assembly.
7. Remove rear moonroof side bracket bolts (↔) and remove moonroof unit assembly.

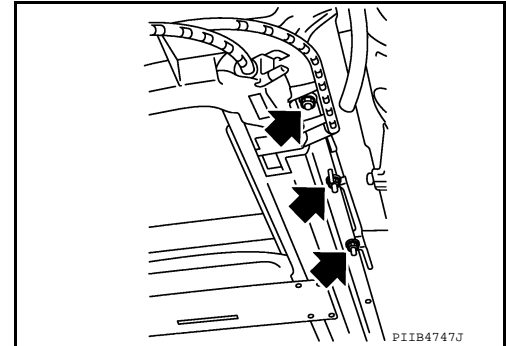

8. Remove moonroof unit assembly through the passenger compartment opening.

CAUTION:

Use care not to damage the seats and trim.

INSTALLATION

1. Loosely tighten the rear moonroof side bracket bolts to the moonroof unit assembly side rails.
2. Install moonroof unit assembly into the passenger compartment, loosely install rear moonroof side bracket bolts to roof panel while supporting front.
3. Align the moonroof unit assembly front end rail and side rails with the locator pins, then loosely install the bolts.
4. Install remaining moonroof side brackets and loosely tighten bolts.
5. Tighten the moonroof unit assembly front end and side rail bolts diagonally.
6. Tighten the front moonroof side bracket bolts at the vehicle side first, then at the side rail end.
7. Tighten the rear moonroof side bracket bolts at the vehicle side first, then at the side rail end.
8. Connect the harness connector to the moonroof motor assembly.
9. Connect drain hoses.
10. Install the headlining. Refer to [INT-24. "Removal and Installation"](#).

SUNSHADE

< REMOVAL AND INSTALLATION >

SUNSHADE

FRONT MOONROOF

FRONT MOONROOF : Removal and Installation

INFOID:000000008511426

REMOVAL

1. Remove moonroof unit assembly. Refer to [RF-55, "Removal and Installation"](#).
2. Remove glass lid. Refer to [RF-49, "Removal and Installation"](#).
3. Remove the sunshade stoppers (1) (LH/RH) from the moonroof unit assembly side rails (2).
⇐: Front
4. Slide sunshade rearward past moonroof unit assembly side rail ends to remove.

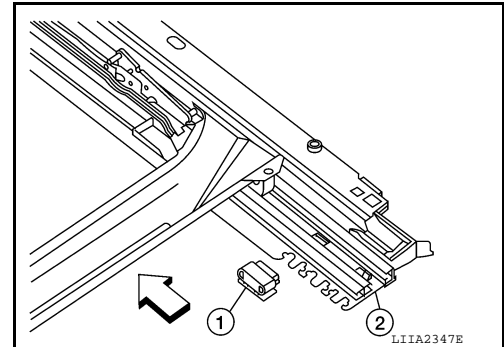

INSTALLATION

1. Move moonroof motor assembly laterally little by little so that the gear is completely engaged into the wire on the moonroof unit assembly, and the mounting surfaces become parallel. Install the moonroof motor assembly screws and tighten.
CAUTION:
Before installing the motor, be sure to place the link and wire assembly in the symmetrical and fully closed position.
NOTE:
If necessary, insert a suitable tool into the drive key and rotate right or left slightly to assist in complete moonroof motor gear alignment.
2. Remainder of installation is in the reverse order of removal.
3. Synchronize moonroof motor assembly with moonroof unit assembly. Refer to [RF-50, "Removal and Installation"](#).

REAR SUNSHADE UNIT

SUNSHADE

< REMOVAL AND INSTALLATION >

REAR SUNSHADE UNIT : Removal and Installation

INFOID:000000008511427

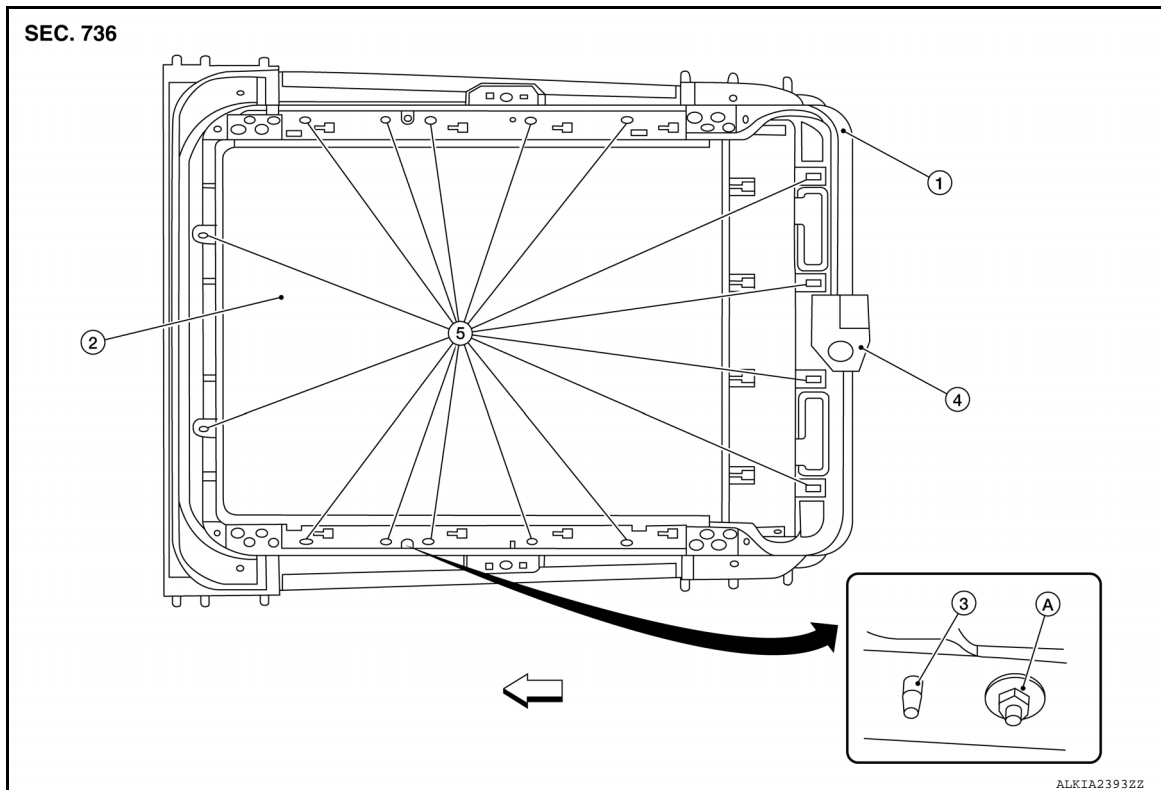

- | | | |
|---------------------------------|------------------|----------------|
| 1. Rear sunshade unit | 2. Rear sunshade | 3. Locator pin |
| 4. Rear sunshade motor assembly | 5. Nut locations | A. Nut |
- ⇐ Front

REMOVAL

1. Remove the headlining. Refer to [INT-24, "Removal and Installation"](#).
2. Disconnect the harness connector from the rear sunshade motor assembly.
3. Remove the nuts that retain the rear sunshade unit.
4. Slide rear sunshade unit (2) rearward and remove through the back door opening (1).

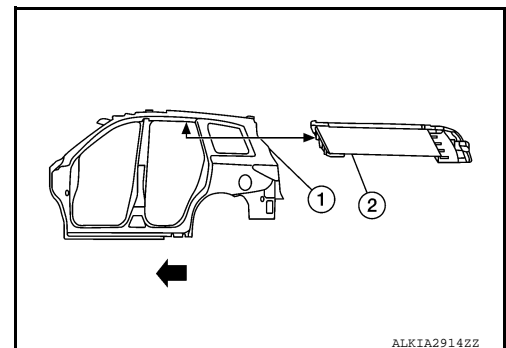

INSTALLATION

Installation is in the reverse order of removal.

SUNSHADE MOTOR ASSEMBLY

< REMOVAL AND INSTALLATION >

SUNSHADE MOTOR ASSEMBLY

REAR SUNSHADE UNIT

REAR SUNSHADE UNIT : Removal and Installation

INFOID:000000008511428

REMOVAL

1. Remove the headlining. Refer to. [INT-24. "Removal and Installation"](#).
2. Disconnect the harness connector (B) from the rear sunshade motor assembly (2).
⇐: Front
3. Remove rear sunshade motor assembly screws (A).
4. Remove the rear sunshade motor assembly (2) from the rear sunshade unit (1).

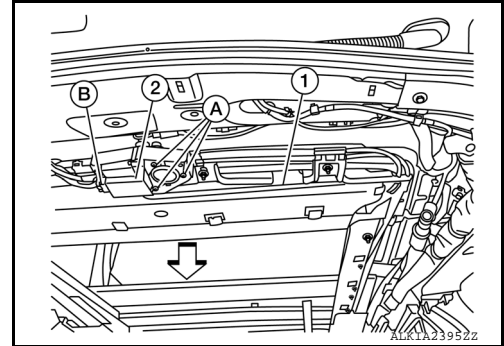

INSTALLATION

Installation is in the reverse order of removal.

A
B
C
D
E
F
G
H
I
J
RF
L
M
N
O
P

WIND DEFLECTOR

< REMOVAL AND INSTALLATION >

WIND DEFLECTOR

Removal and Installation

INFOID:000000008511429

REMOVAL

1. Open the glass lid to view the wind deflector installation point on the moonroof slide rail.
2. Remove two screws then remove the wind deflector link base.
3. Rotate wind deflector, then remove the spring from wind deflector spring base.

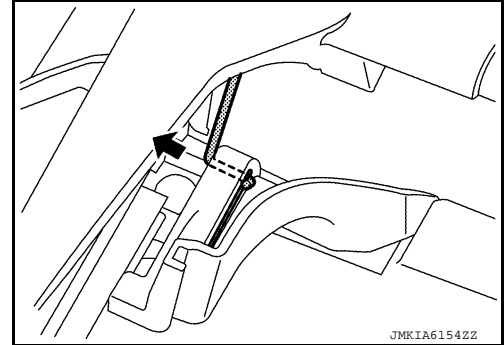

INSTALLATION

Installation is in the reverse order of removal.

MOONROOF SWITCH

< REMOVAL AND INSTALLATION >

MOONROOF SWITCH

Removal and Installation

INFOID:000000008511430

REMOVAL

1. Remove front room/map lamp assembly. Refer to [INL-57. "Removal and Installation"](#).
2. Remove switch cover (1) from the front room/map lamp assembly (2).

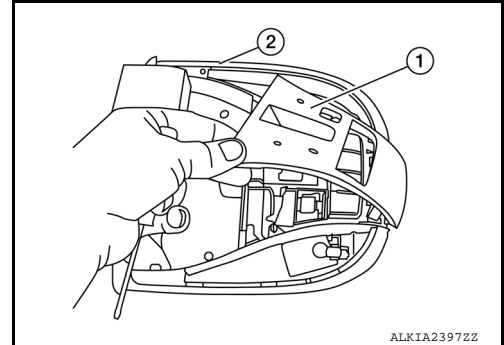

3. Disconnect harness connector (1) using a suitable tool, remove harness connector plate (3) from front room/map lamp assembly (2) and release tabs to remove moonroof switch.

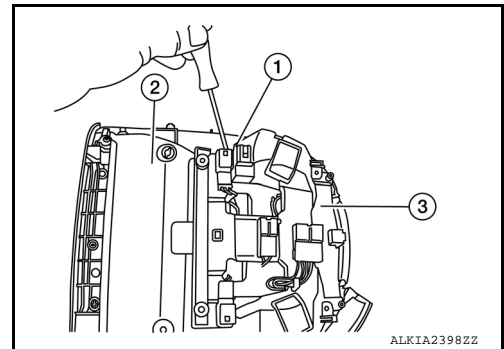

INSTALLATION

Installation is in reverse order of removal.

A
B
C
D
E
F
G
H
I
J
RF
L
M
N
O
P

SUNSHADE SWITCH

< REMOVAL AND INSTALLATION >

SUNSHADE SWITCH

Removal and Installation

INFOID:000000008511431

REMOVAL

1. Remove the headlining. Refer to [INT-24, "Removal and Installation"](#).
2. Disconnect harness connector (1) from sunshade switch (2) and use a suitable tool to remove.

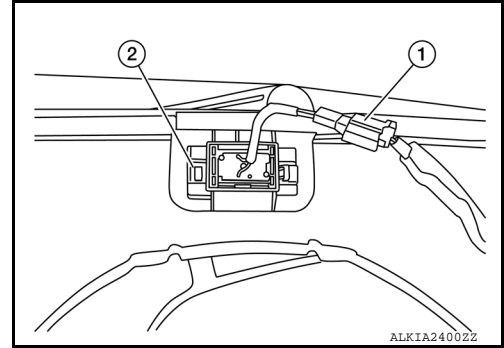

INSTALLATION

Installation is in reverse order of removal.