

SECTION **BRC**

BRAKE CONTROL SYSTEM

A
B
C
D
E
G
H
I
J
K
L
M
N
O
P

CONTENTS

		BRC
VDC/TCS/ABS		
PRECAUTION	TCS FUNCTION	24
PRECAUTIONS	TCS FUNCTION : System Diagram	25
Precaution for Supplemental Restraint System (SRS) "AIR BAG" and "SEAT BELT PRE-TENSIONER"	TCS FUNCTION : System Description	25
Precaution for Brake System	ABS FUNCTION	26
Precaution for Brake Control System	ABS FUNCTION : System Diagram	26
Precaution for Harness Repair	ABS FUNCTION : System Description	27
PREPARATION	EBD FUNCTION	27
PREPARATION	EBD FUNCTION : System Diagram	28
Special Service Tool	EBD FUNCTION : System Description	28
Commercial Service Tools	HILL START ASSIST FUNCTION	29
SYSTEM DESCRIPTION	Hill start assist FUNCTION : System Diagram	30
COMPONENT PARTS	Hill start assist FUNCTION : System Description	30
Component Parts Location	DIAGNOSIS SYSTEM [ABS ACTUATOR AND ELECTRIC UNIT (CONTROL UNIT)]	32
Component Description	CONSULT Function	32
ABS Actuator and Electric Unit (Control Unit)	ECU DIAGNOSIS INFORMATION	37
Wheel Sensor and Sensor Rotor	ABS ACTUATOR AND ELECTRIC UNIT (CONTROL UNIT)	37
Stop Lamp Switch	Reference Value	37
Steering Angle Sensor	Fail-Safe	39
Yaw Rate/Side/Decel G Sensor	DTC Inspection Priority Chart	41
Brake Fluid Level Switch	DTC Index	42
Vacuum Sensor	WIRING DIAGRAM	44
Parking Brake Switch	BRAKE CONTROL SYSTEM	44
VDC OFF Switch	Wiring Diagram	44
SYSTEM	BASIC INSPECTION	52
System Diagram	DIAGNOSIS AND REPAIR WORKFLOW	52
System Description	Work Flow	52
Fail-Safe	Diagnostic Work Sheet	53
VDC FUNCTION	ADDITIONAL SERVICE WHEN REPLACING ABS ACTUATOR AND ELECTRIC UNIT (CONTROL UNIT)	54
VDC FUNCTION : System Diagram		
VDC FUNCTION : System Description		

Description	54	C1143 STEERING ANGLE SENSOR	82
Work Procedure	54	DTC Logic	82
ADJUSTMENT OF STEERING ANGLE SEN-		Diagnosis Procedure	82
SOR NEUTRAL POSITION	55	C1144 INCOMPLETE STEERING ANGLE	
Description	55	SENSOR ADJUSTMENT	84
Work Procedure	55	DTC Logic	84
CALIBRATION OF DECEL G SENSOR	57	Diagnosis Procedure	84
Description	57	C1145, C1146 YAW RATE/SIDE/DECEL G	
Work Procedure	57	SENSOR	85
DTC/CIRCUIT DIAGNOSIS	59	DTC Logic	85
C1101, C1102, C1103, C1104 WHEEL SEN-		Diagnosis Procedure	85
SOR	59	C1155 BRAKE FLUID LEVEL SWITCH	88
DTC Logic	59	DTC Logic	88
Diagnosis Procedure	59	Diagnosis Procedure	88
C1105, C1106, C1107, C1108 WHEEL SEN-		Component Inspection	89
SOR	63	C1160 DECEL G SEN SET	90
DTC Logic	63	DTC Logic	90
Diagnosis Procedure	63	Diagnosis Procedure	90
C1109 POWER AND GROUND SYSTEM	65	C1164, C1165 CV SYSTEM	91
DTC Logic	65	DTC Logic	91
Diagnosis Procedure	65	Diagnosis Procedure	91
C1111 PUMP MOTOR	67	C1170 VARIANT CODING	93
DTC Logic	67	DTC Logic	93
Diagnosis Procedure	67	Diagnosis Procedure	93
C1115 ABS SENSOR [ABNORMAL SIGNAL]..	69	C1197 VACUUM SENSOR	94
DTC Logic	69	DTC Logic	94
Diagnosis Procedure	69	Diagnosis Procedure	94
C1116 STOP LAMP SWITCH	71	C1198 VACUUM SENSOR	96
DTC Logic	71	DTC Logic	96
Diagnosis Procedure	71	Diagnosis Procedure	96
C1120, C1122, C1124, C1126 ABS IN VALVE		C1199 BRAKE BOOSTER	98
SYSTEM	73	DTC Logic	98
DTC Logic	73	Diagnosis Procedure	98
Diagnosis Procedure	73	C119A VACUUM SENSOR	100
C1121, C1123, C1125, C1127 ABS OUT		DTC Logic	100
VALVE SYSTEM	75	Diagnosis Procedure	100
DTC Logic	75	U1000 CAN COMM CIRCUIT	102
Diagnosis Procedure	75	Description	102
C1130 ENGINE SIGNAL	77	DTC Logic	102
DTC Logic	77	Diagnosis Procedure	102
Diagnosis Procedure	77	PARKING BRAKE SWITCH	103
C1140 ACTUATOR RELAY SYSTEM	78	Description	103
DTC Logic	78	Component Function Check	103
Diagnosis Procedure	78	Diagnosis Procedure	103
C1142 PRESS SENSOR	80	Component Inspection	103
DTC Logic	80	VDC OFF SWITCH	104
Diagnosis Procedure	80	Component Function Check	104
		Diagnosis Procedure	104
		Component Inspection	105

ABS WARNING LAMP	106	BRAKE PEDAL VIBRATION OR OPERATION SOUND OCCURS	115	A
Component Function Check	106	Description	115	
Diagnosis Procedure	106	Diagnosis Procedure	115	
BRAKE WARNING LAMP	107	VEHICLE JERKS DURING VDC/TCS/ABS CONTROL	116	B
Component Function Check	107	Description	116	
Diagnosis Procedure	107	Diagnosis Procedure	116	C
VDC OFF INDICATOR LAMP	108	NORMAL OPERATING CONDITION	117	D
Component Function Check	108	Description	117	
Diagnosis Procedure	108	UNIT REMOVAL AND INSTALLATION ...	118	
SLIP INDICATOR LAMP	109	WHEEL SENSOR	118	E
Component Function Check	109	Exploded View - Front Wheel Sensor	118	
Diagnosis Procedure	109	Removal and Installation - Front Wheel Sensor ...	118	
SYMPTOM DIAGNOSIS	110	Exploded View - Rear Wheel Sensor	119	
VDC/TCS/ABS	110	Removal and Installation - Rear Wheel Sensor	120	BRC
Symptom Table	110	SENSOR ROTOR	122	
EXCESSIVE OPERATION FREQUENCY	111	Removal and Installation - Front Sensor Rotor	122	G
Description	111	Removal and Installation - Rear Sensor Rotor	122	
Diagnosis Procedure	111	ABS ACTUATOR AND ELECTRIC UNIT (CONTROL UNIT)	123	H
UNEXPECTED BRAKE PEDAL REACTION ..	112	Exploded View	123	
Description	112	Removal and Installation	123	I
Diagnosis Procedure	112	YAW RATE/SIDE/DECEL G SENSOR	125	J
THE BRAKING DISTANCE IS LONG	113	Exploded View	125	
Description	113	Removal and Installation	125	
Diagnosis Procedure	113	STEERING ANGLE SENSOR	126	K
ABS FUNCTION DOES NOT OPERATE	114	Removal and Installation	126	L
Description	114			M
Diagnosis Procedure	114			N
				O
				P

PRECAUTION

PRECAUTIONS

Precaution for Supplemental Restraint System (SRS) "AIR BAG" and "SEAT BELT PRE-TENSIONER"

INFOID:000000009729281

The Supplemental Restraint System such as "AIR BAG" and "SEAT BELT PRE-TENSIONER", used along with a front seat belt, helps to reduce the risk or severity of injury to the driver and front passenger for certain types of collision. Information necessary to service the system safely is included in the SR and SB section of this Service Manual.

WARNING:

- To avoid rendering the SRS inoperative, which could increase the risk of personal injury or death in the event of a collision which would result in air bag inflation, all maintenance must be performed by an authorized NISSAN/INFINITI dealer.
- Improper maintenance, including incorrect removal and installation of the SRS, can lead to personal injury caused by unintentional activation of the system. For removal of Spiral Cable and Air Bag Module, see the SR section.
- Do not use electrical test equipment on any circuit related to the SRS unless instructed to in this Service Manual. SRS wiring harnesses can be identified by yellow and/or orange harnesses or harness connectors.

PRECAUTIONS WHEN USING POWER TOOLS (AIR OR ELECTRIC) AND HAMMERS

WARNING:

- When working near the Airbag Diagnosis Sensor Unit or other Airbag System sensors with the Ignition ON or engine running, DO NOT use air or electric power tools or strike near the sensor(s) with a hammer. Heavy vibration could activate the sensor(s) and deploy the air bag(s), possibly causing serious injury.
- When using air or electric power tools or hammers, always switch the Ignition OFF, disconnect the battery and wait at least three minutes before performing any service.

Precaution for Brake System

INFOID:000000009177228

WARNING:

Clean any dust from the front brake and rear brake using a vacuum dust collector. Do not blow by compressed air.

- Brake fluid use refer to [MA-15. "FOR USA AND CANADA : Fluids and Lubricants"](#) (United States and Canada) or [MA-16. "FOR MEXICO : Fluids and Lubricants"](#) (Mexico).
- Do not reuse drained brake fluid.
- Do not spill or splash brake fluid on painted surfaces. Brake fluid may seriously damage paint. Wipe it off immediately and wash with water if it gets on a painted surface.
- Always confirm the specified tightening torque when installing the brake pipes.
- After pressing the brake pedal more deeply or harder than normal driving, such as air bleeding, check each item of brake pedal. Adjust brake pedal if it is outside the standard value.
- Do not use mineral oils such as gasoline or light oil to clean. They may damage rubber parts and cause improper operation.
- Always loosen the brake tube flare nut with a flare nut wrench.
- Tighten the brake tube flare nut to the specified torque with a crow-foot (A) and torque wrench (B).
- Always connect the battery terminal when moving the vehicle.
- Turn the ignition switch OFF and disconnect the ABS actuator and electric unit (control unit) harness connector or the battery negative terminal before performing the work.
- Check that no brake fluid leakage is present after replacing the parts.

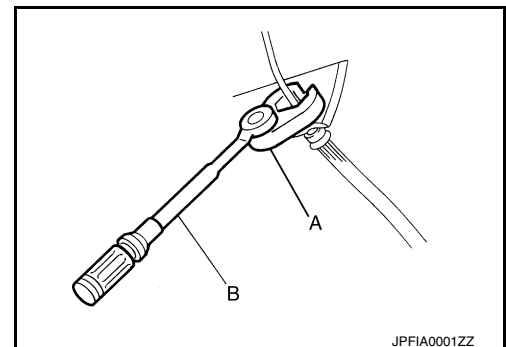

PRECAUTIONS

< PRECAUTION >

[VDC/TCS/ABS]

Precaution for Brake Control System

INFOID:000000009177229

- Just after starting vehicle after ignition switch is ON, brake pedal may vibrate or motor operating noise may be heard from engine compartment. This is a normal condition.
- When an error is indicated by ABS or another warning lamp, collect all necessary information from customer (what symptoms are present under what conditions) and check for simple causes before starting diagnostic servicing. Besides electrical system inspection, check brake booster operation, brake fluid level and oil leaks.
- If tire size and type are used in an improper combination or brake pads are not Genuine NISSAN parts, stopping distance or steering stability may deteriorate.
- ABS might be out of order or malfunctions by putting a radio (wiring inclusive), an antenna and a lead-in wire near the control unit.
- If aftermarket parts (car stereo, CD player, etc.) have been installed, check for incidents such as harness pinches, open circuits, and improper wiring.
- VDC system may not operate normally or a VDC OFF indicator lamp or SLIP indicator lamp may light.
- When replacing the following parts with parts other than genuine parts or making modifications: Suspension-related parts (shock absorber, spring, bushing, etc.), tires, wheels (other than specified sizes), brake-related parts (pad, rotor, caliper, etc.), engine-related parts (muffler, ECM, etc.) and body reinforcement-related parts (roll bar, tower bar, etc.).
- When driving with worn or deteriorated suspension, tires and brake-related parts.

Precaution for Harness Repair

INFOID:000000009177230

- Solder the repair part, and wrap it with tape. [Twisted wire fray must be 110 mm (4.33 in) or less.]

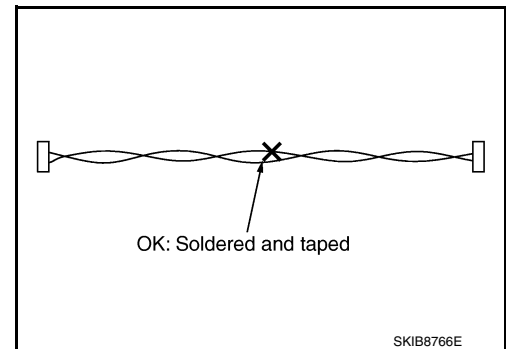

- Do not bypass the repair point with wire. (If it is bypassed, the turn-out point cannot be separated and the twisted wire characteristics are lost.)

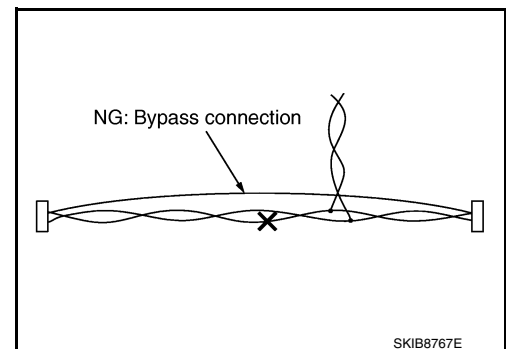

A
B
C
D
E
BRC
G
H
I
J
K
L
M
N
O
P

PREPARATION

< PREPARATION >

[VDC/TCS/ABS]

PREPARATION

PREPARATION

Special Service Tool

INFOID:000000009177231

The actual shapes of Kent-Moore tools may differ from those of special service tools illustrated here.

Tool number (Kent-Moore No.) Tool name	Description
KV991J0080 (J-45741) ABS active wheel sensor tester	Checking operation of ABS active wheel sensors

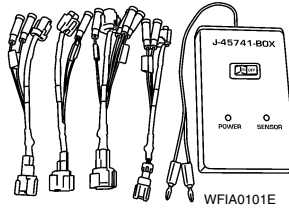

Commercial Service Tools

INFOID:000000009177232

Tool name	Description
1. Flare nut crowfoot 2. Torque wrench	Removing and installing brake piping a: 10 mm (0.39 in)/12 mm (0.47 in)
Power tool	Loosening nuts, screws and bolts

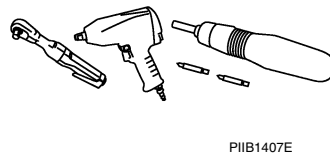
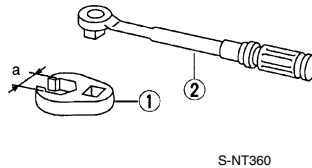

COMPONENT PARTS

< SYSTEM DESCRIPTION >

[VDC/TCS/ABS]

SYSTEM DESCRIPTION

COMPONENT PARTS

Component Parts Location

INFOID:000000009177233

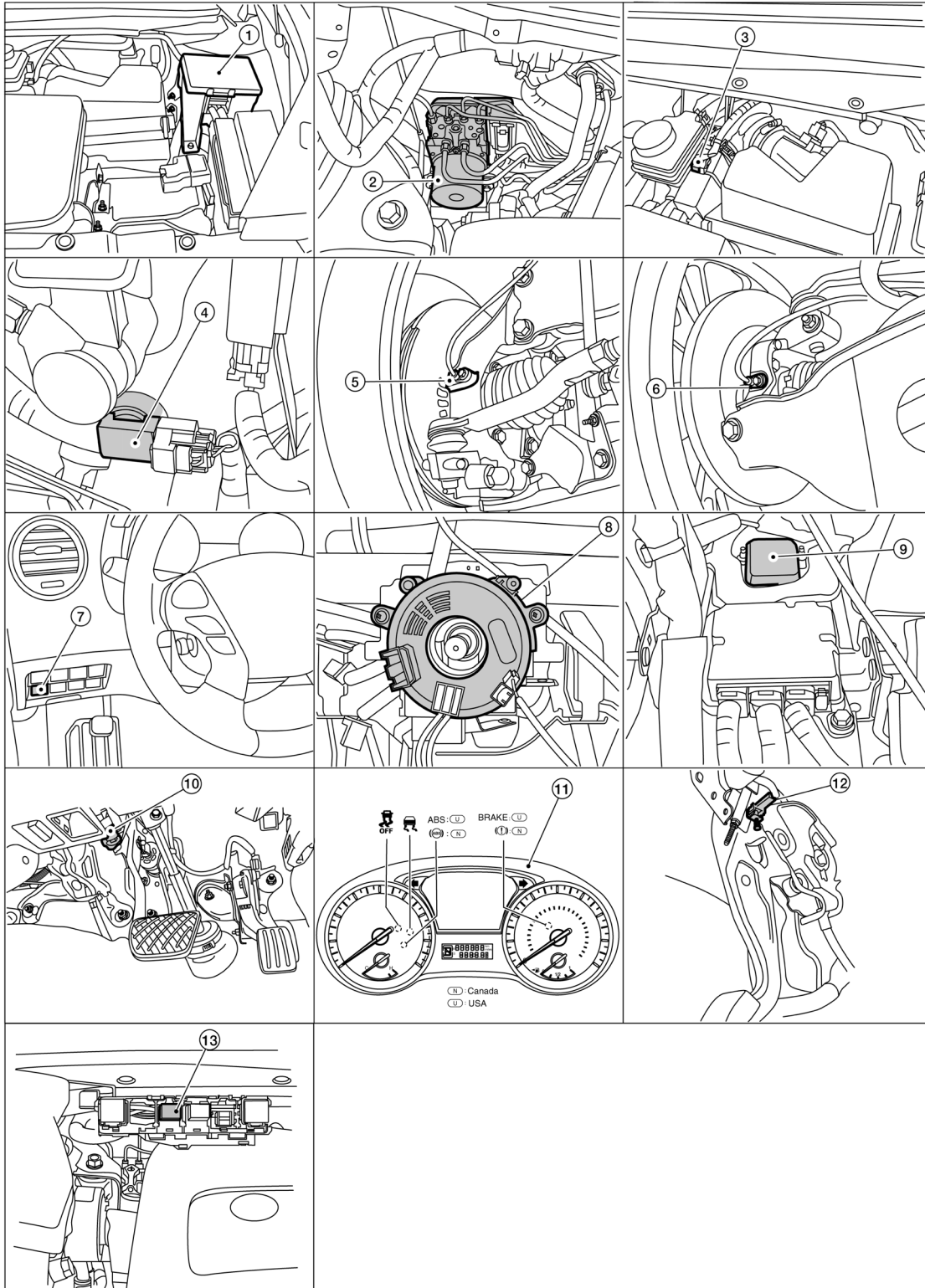

A
B
C
D
E
BRC
G
H
I
J
K
L
M
N
O
P

ALFIA0326ZZ

COMPONENT PARTS

[VDC/TCS/ABS]

< SYSTEM DESCRIPTION >

- | | | |
|--|--|--|
| 1. IPDM E/R | 2. ABS actuator and electric unit (control unit) | 3. Brake fluid level switch (part of brake fluid reservoir) |
| 4. Vacuum sensor (attached to lower side of brake booster) | 5. Front wheel sensor LH (RH similar) | 6. Rear wheel sensor LH (RH similar) |
| 7. VDC OFF switch | 8. Steering angle sensor (view with steering wheel and steering column covers removed) | 9. Yaw rate/side/decel G sensor (view with the center console removed) |
| 10. Stop lamp switch | 11. Combination meter | 12. Parking brake switch |
| 13. Stop lamp relay | | |

Component Description

INFOID:000000009177234

Component		Reference/Function
ABS actuator and electric unit (control unit)	Pump/motor	BRC-8, "ABS Actuator and Electric Unit (Control Unit)"
	Motor relay	
	Actuator relay (main relay)	
	ABS IN valve	
	ABS OUT valve	
	Cut valve 1	
	Cut valve 2	
	Pressure sensor	
Wheel sensor	BRC-9, "Wheel Sensor and Sensor Rotor"	
Stop lamp switch	BRC-9, "Stop Lamp Switch"	
Steering angle sensor	BRC-9, "Steering Angle Sensor"	
Yaw rate/side/decel G sensor	BRC-9, "Yaw Rate/Side/Decel G Sensor"	
Vacuum sensor	BRC-10, "Vacuum Sensor"	
Brake fluid level switch	BRC-10, "Brake Fluid Level Switch"	
Parking brake switch	BRC-10, "Parking Brake Switch"	
VDC OFF switch	BRC-10, "VDC OFF Switch"	
ECM	<p>Mainly transmits the following signals to ABS actuator and electric unit (control unit) via CAN communication.</p> <ul style="list-style-type: none"> • Accelerator pedal position signal • Engine speed signal <p>Mainly receives the following signals from ABS actuator and electric unit (control unit) via CAN communication.</p> <ul style="list-style-type: none"> • Target throttle position signal 	
TCM	<p>Mainly transmits the following signals to ABS actuator and electric unit (control unit) via CAN communication.</p> <ul style="list-style-type: none"> • Shift position signal • Current gear position signal 	
ABS warning lamp	BRC-11, "System Description"	
Brake warning lamp		
VDC OFF indicator lamp		
SLIP indicator lamp		

ABS Actuator and Electric Unit (Control Unit)

INFOID:000000009177235

Electric unit (control unit) is integrated with actuator and motor/accumulator assembly and comprehensively controls VDC function, TCS function, ABS function and EBD function.

ELECTRIC UNIT (CONTROL UNIT)

- Brake fluid pressure, engine and transmission are controlled according to signals from each sensor.
- If malfunction is detected, the system enters fail-safe mode.

COMPONENT PARTS

< SYSTEM DESCRIPTION >

[VDC/TCS/ABS]

ACTUATOR

The following components are integrated with ABS actuator.

Pump

Returns the brake fluid reserved in reservoir to master cylinder by reducing pressure.

Motor

Activates the pump according to signals from ABS actuator and electric unit (control unit).

Motor Relay

Operates the motor ON/OFF according to signals from ABS actuator and electric unit (control unit).

Actuator Relay

Operates each valve ON/OFF according to signals from ABS actuator and electric unit (control unit).

ABS IN Valve and ABS OUT Valve

Increases, holds or decreases the fluid pressure of each caliper according to signals from ABS actuator and electric unit (control unit).

Pressure Sensor

Detects the brake fluid pressure and transmits signal to ABS actuator and electric unit (control unit).

Cut Valve 1 (Primary Line), Cut Valve 2 (Secondary Line)

Shuts off the ordinary brake line from master cylinder when VDC function, TCS function and hill start assist function are activated.

Wheel Sensor and Sensor Rotor

INFOID:000000009177236

NOTE:

- Wheel sensor and sensor rotor is integrated in wheel hub assembly.
- Never measure resistance and voltage value using a tester because sensor is active sensor.
- Downsize and weight reduction is aimed. IC for detection portion and magnet for sensor rotor are adopted.
- Power supply is supplied to detection portion so that magnetic field line is read. Magnetic field that is detected is converted to current signal.
- When sensor rotor rotates, magnetic field changes. Magnetic field change is converted to current signals (rectangular wave) and is transmitted to ABS actuator and electric unit (control unit). Change of magnetic field is proportional to wheel speed.

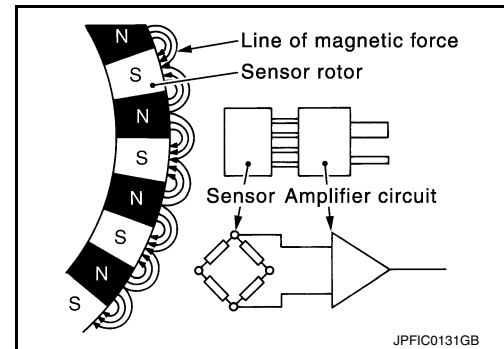

Stop Lamp Switch

INFOID:000000009177237

Detects the operation status of brake pedal and transmits converted electric signal to ABS actuator and electric unit (control unit).

Steering Angle Sensor

INFOID:000000009177238

Detects the following information and transmits steering angle signal to ABS actuator and electric unit (control unit) via CAN communication:

- Steering wheel rotation amount
- Steering wheel rotation angular velocity
- Steering wheel rotation direction

Yaw Rate/Side/Decel G Sensor

INFOID:000000009177239

Calculates the following information that affects the vehicle and transmits a signal to ABS actuator and electric unit (control unit) via communication lines:

- Vehicle rotation angular velocity (yaw rate signal)
- Vehicle lateral acceleration (side G signal) / longitudinal acceleration (decel G signal)

A
B
C
D
E
BRC
G
H
I
J
K
L
M
N
O
P

COMPONENT PARTS

< SYSTEM DESCRIPTION >

[VDC/TCS/ABS]

Brake Fluid Level Switch

INFOID:000000009177240

Detects the brake fluid level in reservoir tank and transmits converted electric signal from ABS actuator and electric unit (control unit) when brake fluid level is the specified level or less.

Vacuum Sensor

INFOID:000000009177241

Detects the vacuum in brake booster and transmits converted electric signal to ABS actuator and electric unit (control unit).

Parking Brake Switch

INFOID:000000009177242

Detects the operation status of parking brake switch and transmits converted electric signal from combination meter to ABS actuator and electric unit (control unit).

VDC OFF Switch

INFOID:000000009177243

- This is an integrated switch with switches for other functions.
- Non-operational status or standby status of the following functions can be selected using VDC OFF switch. VDC OFF indicator lamp indicates the operation status of function. (ON: Non-operational status, OFF: Standby status)
 - VDC function
- **NOTE:**
 - Brake limited slip differential (BLSD) control operates.
 - TCS function
- VDC OFF indicator lamp turns OFF (standby status) when the engine is started again after it is stopped once while VDC OFF indicator lamp is ON (non-operational status).

SYSTEM

System Diagram

INFOID:000000009177244

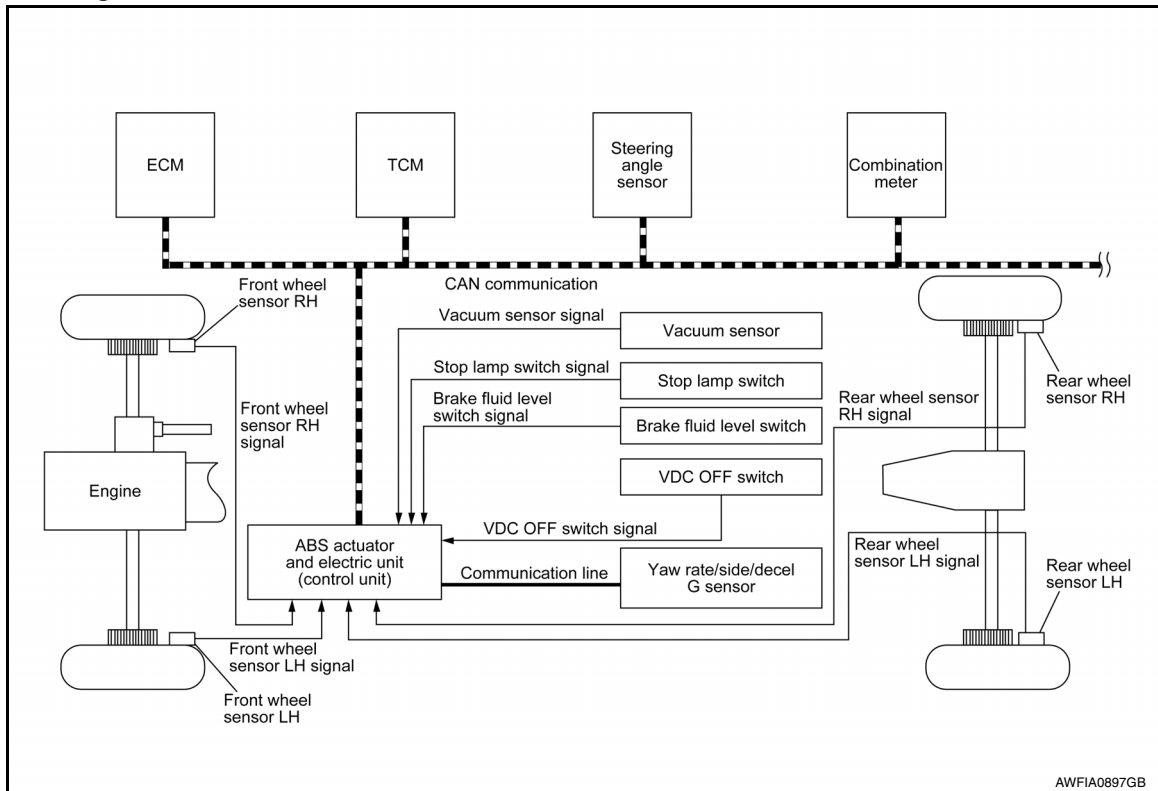

A
B
C
D
E
BRC
G
H
I

System Description

INFOID:000000009177245

- The system switches fluid pressure of each brake caliper to increase, to hold or to decrease according to signals from control unit in ABS actuator and electric unit (control unit). This control system is applied to VDC function, TCS function, ABS function, EBD function and hill start assist function.
- Fail-safe function is available for each function and is activated by each function when system malfunction occurs.

INPUT SIGNAL AND OUTPUT SIGNAL

Major signal transmission between each unit via communication lines is shown in the following table.

VDC function, TCS function, ABS function and EBD function

Component	Signal description
Yaw rate/side/decel G sensor	Mainly transmits the following signals to ABS actuator and electric unit (control unit) via communication line*1: <ul style="list-style-type: none"> • Yaw rate signal • Side G sensor signal • Decel G sensor signal
ECM	Mainly transmits the following signals to ABS actuator and electric unit (control unit) via CAN communication: <ul style="list-style-type: none"> • Accelerator pedal position signal • Engine speed signal Mainly receives the following signals from ABS actuator and electric unit (control unit) via CAN communication. <ul style="list-style-type: none"> • Target throttle position signal
TCM	Mainly transmits the following signals to ABS actuator and electric unit (control unit) via CAN communication: <ul style="list-style-type: none"> • Shift position signal

J
K
L
M
N
O
P

SYSTEM

< SYSTEM DESCRIPTION >

[VDC/TCS/ABS]

Component	Signal description
Steering angle sensor	Mainly transmits the following signals to ABS actuator and electric unit (control unit) via CAN communication. <ul style="list-style-type: none"> • Steering angle sensor signal
Combination meter	Mainly transmits the following signals to ABS actuator and electric unit (control unit) via CAN communication: <ul style="list-style-type: none"> • Brake fluid level switch signal • Parking brake switch signal Mainly receives the following signals from ABS actuator and electric unit (control unit) via CAN communication: <ul style="list-style-type: none"> • ABS warning lamp signal • Brake warning lamp signal • VDC warning lamp signal • VDC OFF indicator lamp

*1: Communication line between yaw rate/side/decel G sensor and ABS actuator and electric unit (control unit)

VALVE OPERATION (ABS AND EBD)

Each valve is operated and fluid pressure of brake caliper is controlled.

When ordinary brake is applied and ABS is in ABS operation (when pressure increases).

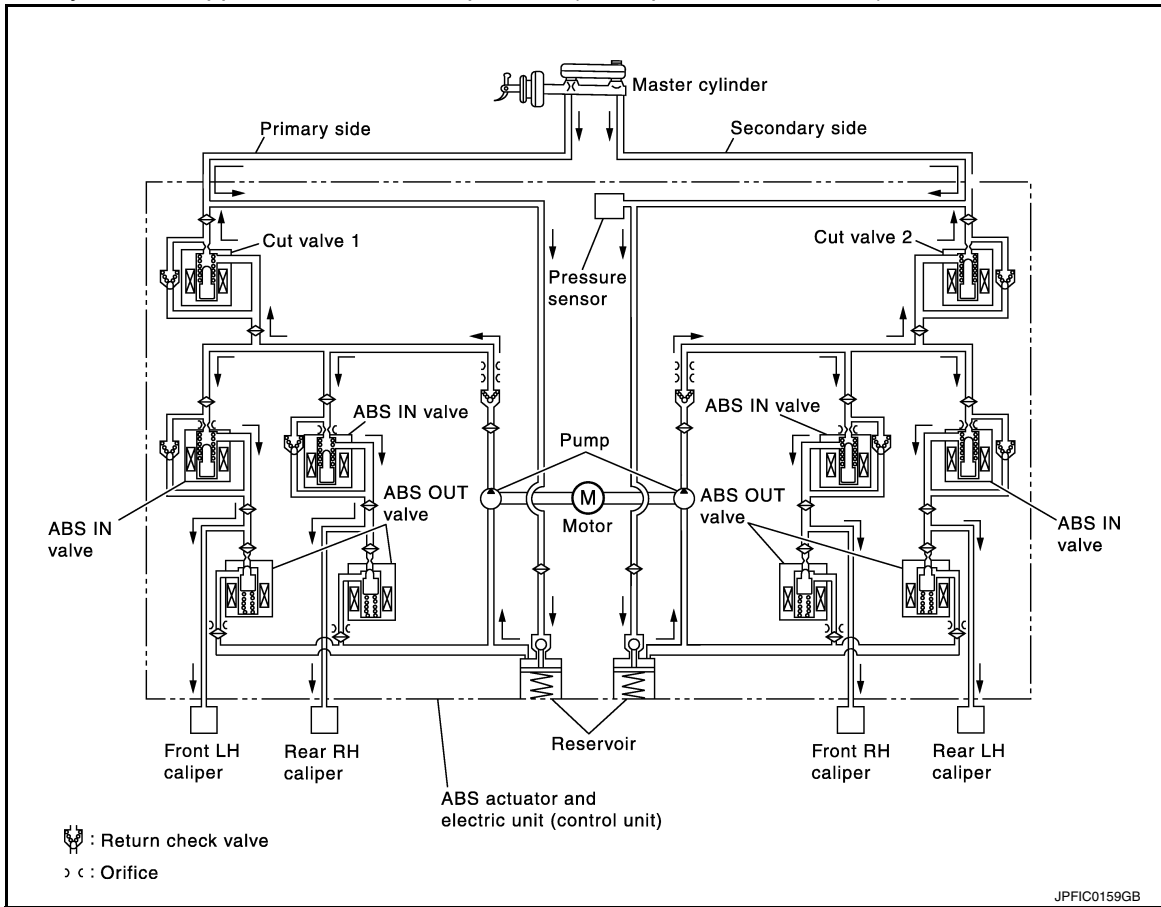

Name	Not activated	When Pressure Increases
Cut valve 1	Power supply is not supplied (open)	Power supply is not supplied (open)
Cut valve 2	Power supply is not supplied (open)	Power supply is not supplied (open)
ABS IN valve	Power supply is not supplied (open)	Power supply is not supplied (open)
ABS OUT valve	Power supply is not supplied (close)	Power supply is not supplied (close)
Each caliper (fluid pressure)	—	Pressure increases

When front RH wheel caliper pressure increases

SYSTEM

[VDC/TCS/ABS]

< SYSTEM DESCRIPTION >

- Motor is activated. Brake fluid is pressurized by pump and is sent to secondary line through cut valve 2. At the same time, pressurized brake fluid is supplied to front RH caliper through ABS IN valve.

When front LH wheel caliper pressure increases

- Motor is activated. Brake fluid is pressurized by pump and is sent to primary line through cut valve 1. At the same time, pressurized brake fluid is supplied to front LH wheel caliper through ABS IN valve.

When rear RH wheel caliper pressure increases

- Motor is activated. Brake fluid is pressurized by pump and is sent to primary line through cut valve 1. At the same time, pressurized brake fluid is supplied to rear RH wheel caliper through ABS IN valve.

When rear LH wheel caliper pressure increases

- Motor is activated. Brake fluid is pressurized by pump and is sent to secondary line through cut valve 2. At the same time, pressurized brake fluid is supplied to rear LH wheel caliper through ABS IN valve.

When ABS operation starts (when pressure holds)

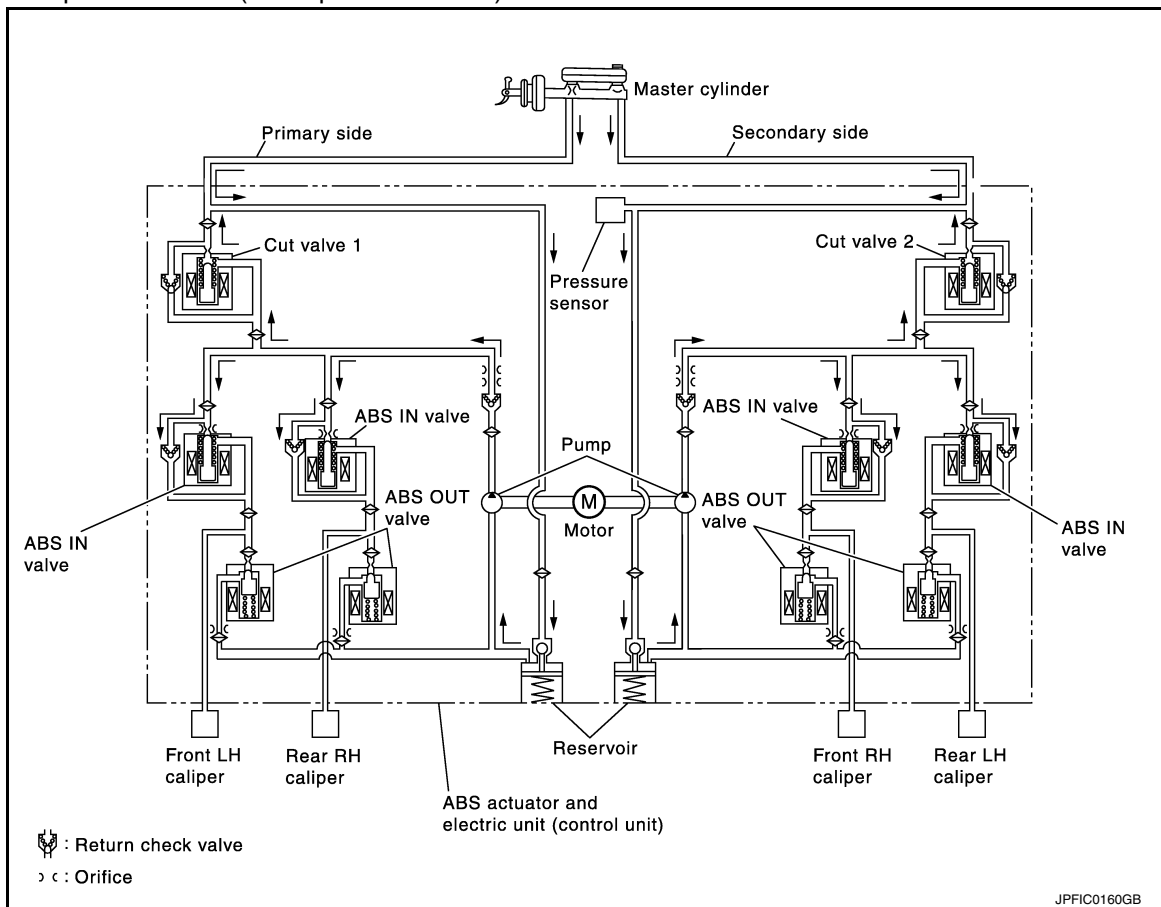

Name	Not activated	When pressure holds
Cut valve 1	Power supply is not supplied (open)	Power supply is not supplied (open)
Cut valve 2	Power supply is not supplied (open)	Power supply is not supplied (open)
ABS IN valve	Power supply is not supplied (open)	Power supply is supplied (close)
ABS OUT valve	Power supply is not supplied (close)	Power supply is not supplied (close)
Each caliper (fluid pressure)	—	Pressure holds

When front RH wheel caliper pressure holds

- Motor is activated. Brake fluid is pressurized by pump and is sent to secondary line through cut valve 2. At the same time, because ABS IN valve and ABS OUT valve are closed, fluid pressure holds.

When front LH wheel caliper pressure holds

- Motor is activated. Brake fluid is pressurized by pump and is sent to primary line through cut valve 1. At the same time, because ABS IN valve and ABS OUT valve are closed, fluid pressure holds.

SYSTEM

[VDC/TCS/ABS]

< SYSTEM DESCRIPTION >

When rear RH wheel caliper pressure holds

- Motor is activated. Brake fluid is pressurized by pump and is sent to primary line through cut valve 1. At the same time, because ABS IN valve and ABS OUT valve are closed, fluid pressure holds.

When rear LH wheel caliper pressure holds

- Motor is activated. Brake fluid is pressurized by pump and is sent to secondary line through cut valve 2. At the same time, because ABS IN valve and ABS OUT valve are closed, fluid pressure holds.

ABS is in operation (when pressure decreases)

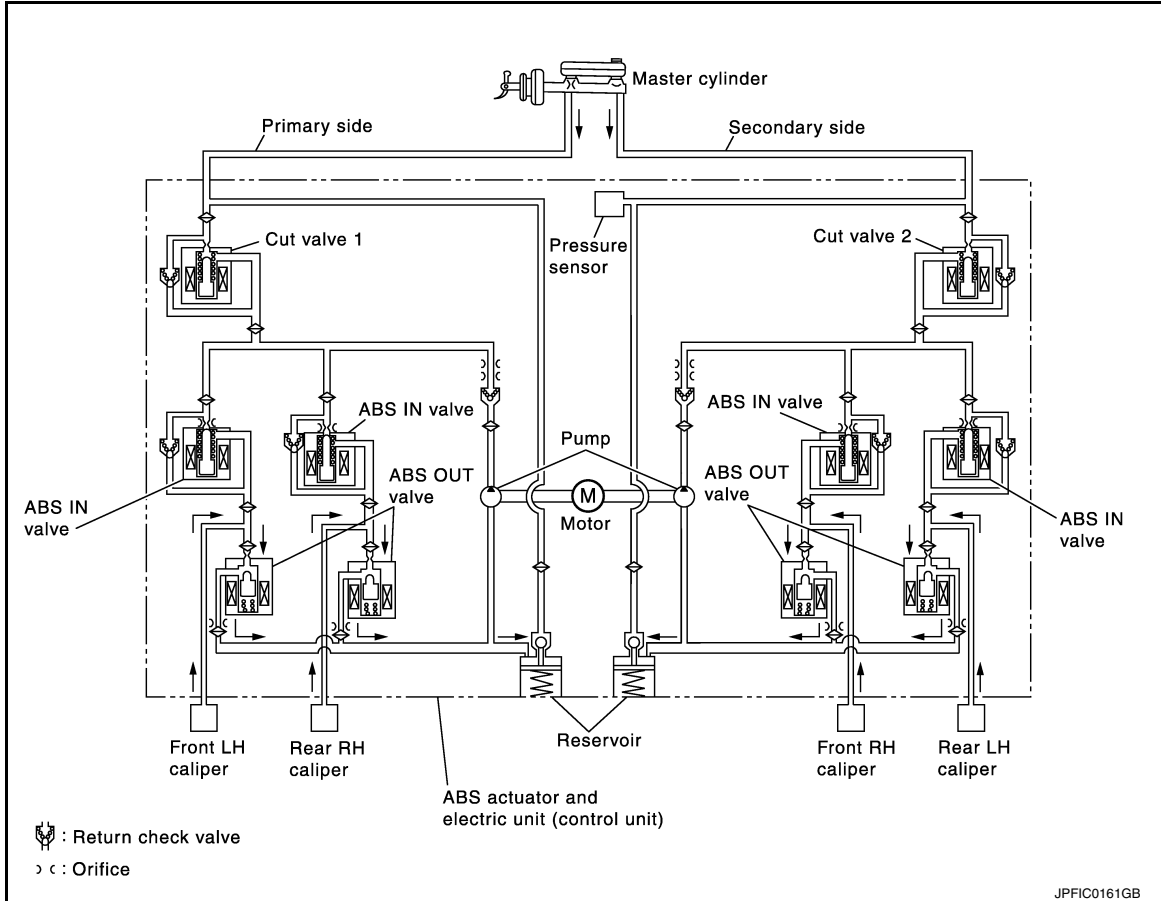

Name	Not activated	When pressure decreases
Cut valve 1	Power supply is not supplied (open)	Power supply is not supplied (open)
Cut valve 2	Power supply is not supplied (open)	Power supply is not supplied (open)
ABS IN valve	Power supply is not supplied (open)	Power supply is supplied (close)
ABS OUT valve	Power supply is not supplied (close)	Power supply is supplied (open)
Each caliper (fluid pressure)	—	Pressure decreases

When front RH wheel caliper pressure decreases

- Being supplied to reservoir through ABS OUT valve, the fluid pressure of brake caliper is decreased.

When front LH wheel caliper pressure decreases

- Being supplied to reservoir through ABS OUT valve, the fluid pressure of brake caliper is decreased.

When rear RH wheel caliper pressure decreases

- Being supplied to reservoir through ABS OUT valve, the fluid pressure of brake caliper is decreased.

When rear LH wheel caliper pressure decreases

- Being supplied to reservoir through ABS OUT valve, the fluid pressure of brake caliper is decreased.

Component Parts and Function

SYSTEM

< SYSTEM DESCRIPTION >

[VDC/TCS/ABS]

Component	FUNCTION
Reservoir	Temporarily reserves the brake fluid drained from brake caliper, so that pressure efficiently decreases when decreasing pressure of brake caliper.
Pump	Returns the brake fluid reserved in reservoir to master cylinder by reducing pressure.
Motor	Drives the pump according to signals from control unit.
ABS IN valve	Switches the fluid pressure line to increase or hold according to signals from control unit.
ABS OUT valve	Switches the fluid pressure line to increase, hold or decrease according to signals from control unit.
Return check valve	Returns the brake fluid from brake caliper to master cylinder by bypassing orifice of each valve when brake is released.
Cut valve 1 Cut valve 2	Performs the duty control of fluid pressure increased by pump according to signals from control unit.
Pressure Sensor	Detects the brake pedal operation amount.

VALVE OPERATION (OTHER THAN ABS AND EBD)

Each valve is operated and fluid pressure of brake caliper is controlled.

NOTE:

There is no operation to hold and increase pressure for functions other than ABS and EBD.

When Pressure Increases

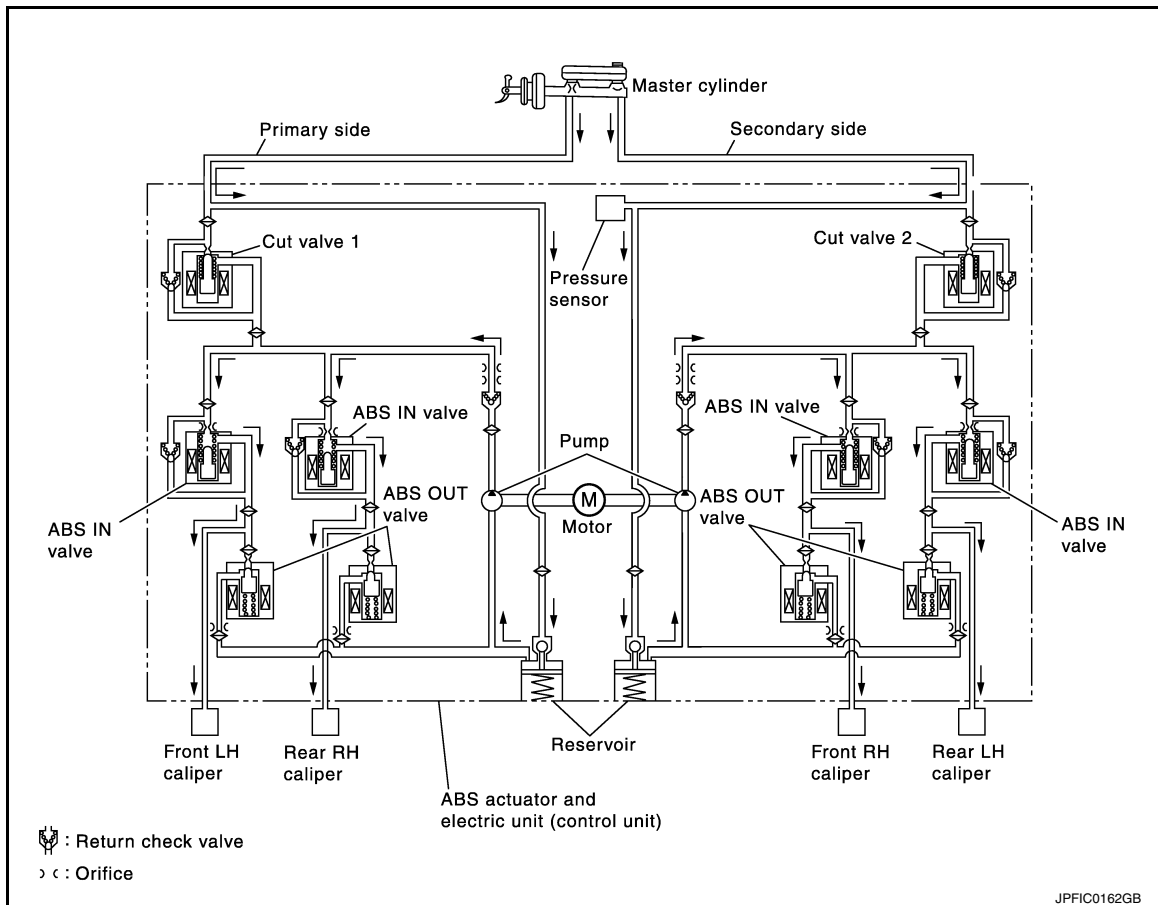

SYSTEM

< SYSTEM DESCRIPTION >

[VDC/TCS/ABS]

Name	Not activated	When Pressure Increases
Cut valve 1	Power supply is not supplied (open)	Wheel other than the one that the pressure is to be increased: Power supply is not supplied (open) Only wheel that the pressure is to be increased: Power supply is supplied (close)
Cut valve 2	Power supply is not supplied (open)	Wheel other than the one that the pressure is to be increased: Power supply is not supplied (open) Only wheel that the pressure is to be increased: Power supply is supplied (close)
ABS IN valve	Power supply is not supplied (open)	Only wheel that the pressure is to be increased: Power supply is not supplied (open) Wheel other than the one that the pressure is to be increased: Power supply is supplied (close)
ABS OUT valve	Power supply is not supplied (close)	Power supply is not supplied (close)
Each caliper (fluid pressure)	—	Pressure increases

When front RH wheel caliper pressure increases

- Motor is activated. Brake fluid from pump is supplied to front RH wheel caliper through ABS IN valve. For other wheel, ABS IN valve is closed and brakes fluid is not supplied to caliper.

When front LH wheel caliper pressure increases

- Motor is activated. Brake fluid from pump is supplied to front LH wheel caliper through ABS IN valve. For other wheel, ABS IN valve is closed and brakes fluid is not supplied to caliper.

When rear RH wheel caliper pressure increases

- Motor is activated. Brake fluid from pump is supplied to front RH wheel caliper through ABS IN valve. For other wheel, ABS IN valve is closed and brakes fluid is not supplied to caliper.

When rear LH wheel caliper pressure increases

- Motor is activated. Brake fluid from pump is supplied to front LH wheel caliper through ABS IN valve. For other wheel, ABS IN valve is closed and brakes fluid is not supplied to caliper.

SYSTEM

< SYSTEM DESCRIPTION >

[VDC/TCS/ABS]

Released

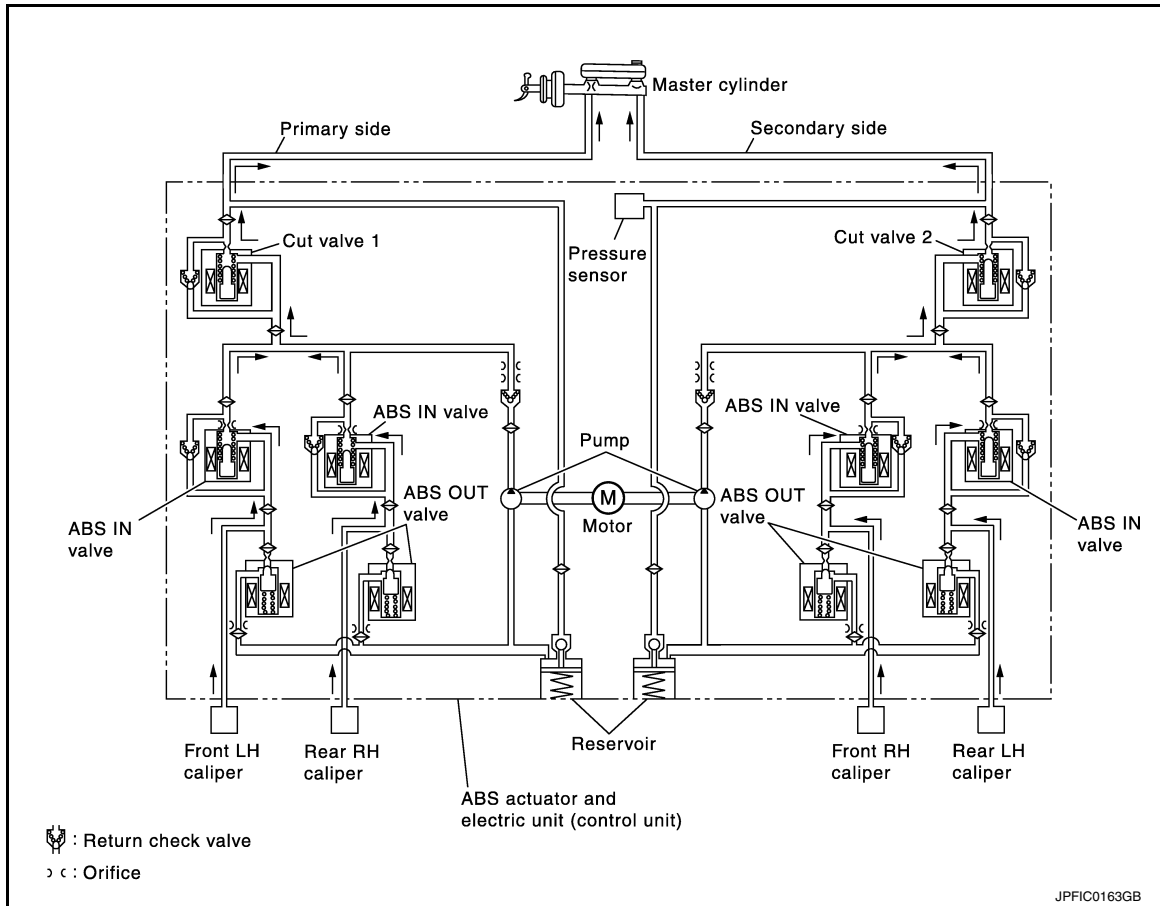

Name	Not activated	When pressure decreases
Cut valve 1	Power supply is not supplied (open)	Power supply is not supplied (open)
Cut valve 2	Power supply is not supplied (open)	Power supply is not supplied (open)
ABS IN valve	Power supply is not supplied (open)	Power supply is not supplied (open)
ABS OUT valve	Power supply is not supplied (close)	Power supply is supplied (open)
Each caliper (fluid pressure)	—	Pressure decreases

When front RH wheel caliper pressure decreases

- Being returned to master cylinder through ABS IN valve, fluid pressure of brake caliper is decreased.

When front LH wheel caliper pressure decreases

- Being returned to master cylinder through ABS IN valve, fluid pressure of brake caliper is decreased.

When rear RH wheel caliper pressure decreases

- Being returned to master cylinder through ABS IN valve, fluid pressure of brake caliper is decreased.

When rear LH wheel caliper pressure decreases

- Being returned to master cylinder through ABS IN valve, fluid pressure of brake caliper is decreased.

Component Parts and Function

Component	Function
Reservoir	Temporarily reserves the brake fluid drained from brake caliper so that pressure efficiently decreases when decreasing pressure of brake caliper.
Pump	Returns the brake fluid reserved in reservoir to master cylinder by reducing pressure.
Motor	Drives the pump according to signals from control unit.
ABS IN valve	Switches the fluid pressure line to increase or hold according to signals from control unit.

SYSTEM

[VDC/TCS/ABS]

< SYSTEM DESCRIPTION >

Component	Function
ABS OUT valve	Switches the fluid pressure line to increase, hold or decrease according to signals from control unit.
Return check valve	Returns the brake fluid from brake caliper to master cylinder by bypassing orifice of each valve when brake is released.
Cut valve 1 Cut valve 2	Performs the duty control of fluid pressure increased by pump according to signals from control unit.
Pressure Sensor	Detects the brake pedal operation amount.

CONDITIONS FOR TURNING ON THE WARNING LAMP

ABS Warning Lamp

- Turns ON at the same time as VDC warning lamp when either ABS function or EBD function is malfunctioning.
- Turns ON when ignition switch turns ON and turns OFF when the system is normal, for bulb check purposes.

Condition (status)	ABS warning lamp
Ignition switch OFF	OFF
For approx. 1 second after the ignition switch is turned ON	ON
Approx. 1 second after ignition switch is turned ON (when the system is in normal operation)	OFF
ABS function is malfunctioning	ON
EBD function is malfunctioning	ON

Brake Warning Lamp

- Turns ON at the same time as ABS warning lamp and VDC warning lamp when EBD function is malfunctioning.
- Turns ON when ignition switch turns ON and turns OFF when the system is normal for bulb check purposes.

Condition (status)	Brake warning lamp
Ignition switch OFF	OFF
For approx. 1 seconds after the ignition switch is turned ON	ON
Approx. 1 second after ignition switch is turned ON (when the system is in normal operation)	OFF
After engine starts	OFF
When parking brake operates (parking brake switch ON)	ON
When brake booster vacuum decreases	ON
When vacuum sensor is malfunctioning	ON
When brake fluid is less than the specified level (brake fluid level switch ON)	ON
ABS function is malfunctioning	OFF
EBD function is malfunctioning	ON

VDC Warning Lamp

- Turns ON when either VDC function, TCS function, ABS function or EBD function is malfunctioning.
- Turns ON when ignition switch turns ON and turns OFF when the system is normal for bulb check purposes.

Condition (status)	VDC warning lamp
Ignition switch OFF	OFF
For approx. 1 second after the ignition switch is turned ON	ON
Approx. 1 second after ignition switch is turned ON (when the system is in normal operation)	OFF
VDC function is malfunctioning	ON
TCS function is malfunctioning	ON

SYSTEM

< SYSTEM DESCRIPTION >

[VDC/TCS/ABS]

Condition (status)	VDC warning lamp
ABS function is malfunctioning	ON
EBD function is malfunctioning	ON
VDC function is operating	Blinking
TCS function is operating	Blinking

CONDITIONS FOR TURNING ON THE INDICATOR LAMP

VDC OFF indicator lamp

- Turns ON when VDC function and TCS function are switched to non-operational status (OFF) by VDC OFF switch.
- Turns ON when ignition switch turns ON and turns OFF when the system is normal for bulb check purposes.

Condition (status)	VDC OFF indicator lamp
Ignition switch OFF	OFF
For approx. 1 second after the ignition switch is turned ON	ON
Approx. 1 second after ignition switch is turned ON (when the system is in normal operation)	OFF
When VDC OFF switch is ON (VDC function and TCS function are OFF)	ON

Fail-Safe

INFOID:000000009177246

VDC FUNCTION, TCS FUNCTION and hill start assist FUNCTION

VDC warning lamp in combination meter turns ON when a malfunction occurs in system [ABS actuator and electric unit (control unit)]. The control is suspended for VDC function, TCS function and hill start assist function. The vehicle status becomes the same as models without VDC function, TCS function and hill start assist function. However, ABS function and EBD function are operated normally.

ABS FUNCTION

ABS warning lamp and VDC warning lamp in combination meter turn ON when a malfunction occurs in system [ABS actuator and electric unit (control unit)]. The control is suspended for VDC function, TCS function, ABS function and hill start assist function. The vehicle status becomes the same as models without VDC function, TCS function, ABS function and hill start assist function. However, EBD function is operated normally.

NOTE:

ABS self-diagnosis sound may be heard the same as in the normal condition because self-diagnosis is performed when ignition switch turns ON and when vehicle initially starts.

EBD FUNCTION

ABS warning lamp, brake warning lamp and VDC warning lamp in combination meter turn ON when a malfunction occurs in system [ABS actuator and electric unit (control unit)]. The control is suspended for VDC function, TCS function, ABS function, EBD function and hill start assist function. The vehicle status becomes the same as models without VDC function, TCS function, ABS function, EBD function and hill start assist function.

SYSTEM

< SYSTEM DESCRIPTION >

[VDC/TCS/ABS]

DTC	Malfunction detected condition	Fail-safe condition	
C1101	When an open circuit is detected in rear RH wheel sensor circuit.	The following functions are suspended: • VDC function • TCS function • ABS function • EBD function (only when both 2 rear wheels are malfunctioning) • hill start assist function	
C1102	When an open circuit is detected in rear LH wheel sensor circuit.		
C1103	When an open circuit is detected in front RH wheel sensor circuit.		
C1104	When an open circuit is detected in front LH wheel sensor circuit.		
C1105	<ul style="list-style-type: none"> • When power supply voltage of rear RH wheel sensor is low. • When distance between rear RH wheel sensor and rear RH wheel sensor rotor is large. • When installation of rear RH wheel sensor or rear RH wheel sensor rotor is not normal. 		
C1106	<ul style="list-style-type: none"> • When power supply voltage of rear LH wheel sensor is low. • When distance between rear LH wheel sensor and rear LH wheel sensor rotor is large. • When installation of rear LH wheel sensor or rear LH wheel sensor rotor is not normal. 		
C1107	<ul style="list-style-type: none"> • When power supply voltage of front RH wheel sensor is low. • When distance between front RH wheel sensor and front RH wheel sensor rotor is large. • When installation of front RH wheel sensor or front RH wheel sensor rotor is not normal. 		
C1108	<ul style="list-style-type: none"> • When power supply voltage of front LH wheel sensor is low. • When distance between front LH wheel sensor and front LH wheel sensor rotor is large. • When installation of front LH wheel sensor or front LH wheel sensor rotor is not normal. 		
C1109	<ul style="list-style-type: none"> • When ignition voltage is 10 V or less. • When ignition voltage is 16 V or more. 		The following functions are suspended: • VDC function • TCS function • ABS function • EBD function • hill start assist function
C1111	When a malfunction is detected in motor or motor relay.		
C1115	When difference in wheel speed between any wheel and others is detected during the vehicle is driven, because of installation of other tires than specified.	The following functions are suspended: • VDC function • TCS function • ABS function • hill start assist function	
C1116	When stop lamp switch signal is not input when brake pedal operates.		
C1120	When a malfunction is detected in front LH ABS IN valve.	The following functions are suspended: • VDC function • TCS function • ABS function • EBD function • hill start assist function	
C1121	When a malfunction is detected in front LH ABS OUT valve.		
C1122	When a malfunction is detected in front RH ABS IN valve.		
C1123	When a malfunction is detected in front RH ABS OUT valve.		
C1124	When a malfunction is detected in rear LH ABS IN valve.		
C1125	When a malfunction is detected in rear LH ABS OUT valve.		
C1126	When a malfunction is detected in rear RH ABS IN valve.		
C1127	When a malfunction is detected in rear RH ABS OUT valve.		
C1130	When a malfunction is detected in ECM system.	The following functions are suspended: • VDC function • TCS function • hill start assist function	

SYSTEM

< SYSTEM DESCRIPTION >

[VDC/TCS/ABS]

DTC	Malfunction detected condition	Fail-safe condition
C1140	When a malfunction is detected in actuator relay.	The following functions are suspended: <ul style="list-style-type: none"> • VDC function • TCS function • ABS function • EBD function • hill start assist function
C1142	When a malfunction is detected in pressure sensor.	The following functions are suspended: <ul style="list-style-type: none"> • VDC function • TCS function • hill start assist function
C1143	When a malfunction is detected in steering angle sensor.	
C1144	When neutral position adjustment of steering angle sensor is not complete.	
C1145	When a malfunction is detected in yaw rate signal.	
C1146	When a malfunction is detected in side/decel G signal.	The following functions are suspended: <ul style="list-style-type: none"> • VDC function • TCS function • ABS function • hill start assist function
C1155	When brake fluid level low signal is detected.	
C1160	When calibration of yaw rate/side/decel G sensor is not complete.	The following functions are suspended: <ul style="list-style-type: none"> • VDC function • TCS function • hill start assist function
C1164	When a malfunction is detected in cut valve 1.	The following functions are suspended: <ul style="list-style-type: none"> • VDC function • TCS function • ABS function • EBD function • hill start assist function
C1165	When a malfunction is detected in cut valve 2.	
C1170	When the information in ABS actuator and electric unit (control unit) is not the same.	Electrical vacuum assistance of brake booster is suspended.
C1197	When a malfunction is detected in vacuum sensor.	
C1198	<ul style="list-style-type: none"> • When an open circuit is detected in vacuum sensor circuit. • When a short circuit is detected in vacuum sensor circuit. • When a malfunction is detected in vacuum sensor noise. 	—
C1199	When brake booster vacuum is approx. 0 kPa (0 mmHg) during engine running.	
C119A	When a malfunction is detected in supply power voltage of vacuum sensor.	Electrical vacuum assistance of brake booster is suspended.
U1000	When CAN communication signal is not continuously received for 2 seconds or more.	The following functions are suspended: <ul style="list-style-type: none"> • VDC function • TCS function • hill start assist function

VDC FUNCTION

VDC FUNCTION : System Diagram

INFOID:000000009177247

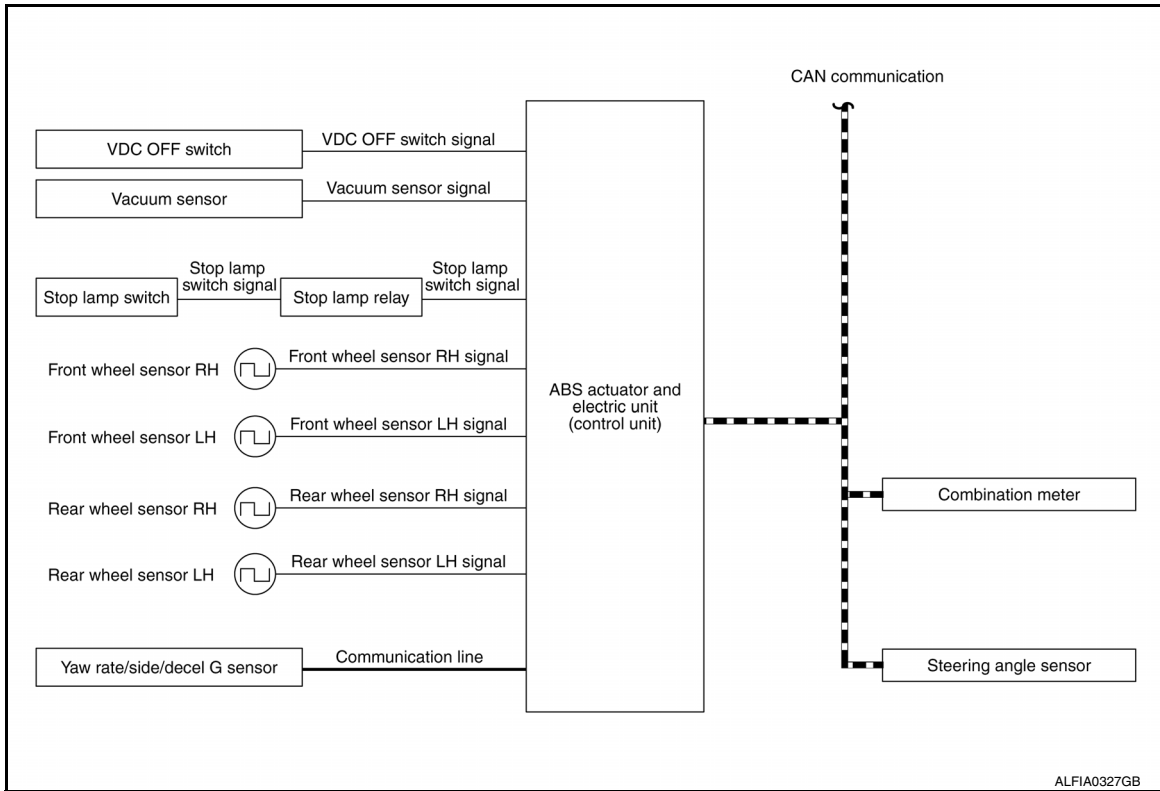

VDC FUNCTION : System Description

INFOID:000000009177248

- Side slip or tail slip may occur while driving on a slippery road or during intended urgent evasive driving. VDC function detects side slip status using each sensor when side slip or tail slip is about to occur and improves vehicle stability by brake control and engine output control during driving.
- In addition to ABS function, EBD function and TCS function, target side slip amount is calculated according to steering operation amount from steering angle sensor and brake operation amount from brake pressure sensor. By comparing this information with vehicle side slip amount that is calculated from information from yaw rate/side/decel G sensor and wheel sensor, vehicle driving conditions (conditions of understeer or oversteer) are judged and vehicle stability is improved by brake force control on all 4 wheels and engine output control.

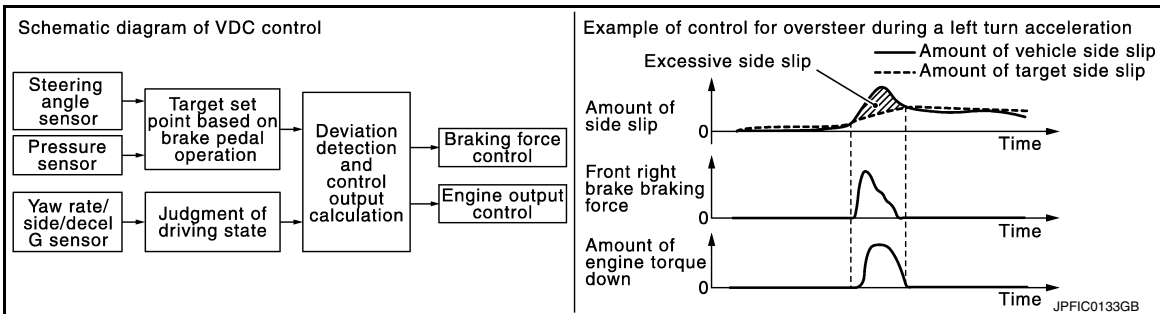

- VDC function can be switched to non-operational status (OFF) by operating VDC OFF switch. In this case, VDC OFF indicator lamp turns ON.
- Control unit portion automatically improves driving stability by performing brake force control as well as engine output control by transmitting drive signal to actuator portion according to difference between target side slip amount and vehicle side slip amount
- VDC warning lamp blinks while VDC function is in operation and indicates to the driver that the function is in operation.
- VDC function has brake limited slip differential (BLSD) function. LH and RH driving wheel spin is always monitored. If necessary, appropriate brake force is independently applied to LH or RH driving wheel so that one-sided wheel spin is avoided and traction is maintained. Mainly starting ability is improved. [Brake limited slip differential (BLSD) function operates while VDC function is in non-operational status (OFF) by VDC OFF

SYSTEM

< SYSTEM DESCRIPTION >

[VDC/TCS/ABS]

- switch.] VDC warning lamp turns ON when Brake limited slip differential (BLSD) function is in operation. Noises and vibration may be generated due to brake operation. This is not a malfunction.
- CONSULT can be used to diagnose the system.
 - Fail-safe function is adopted. When a malfunction occurs in VDC function, the control is suspended for VDC function, TCS function and hill start assist function. The vehicle status becomes the same as models without VDC function, TCS function and hill start assist function. However, ABS function and EBD function are operated normally. Refer to [BRC-19. "Fail-Safe"](#).

NOTE:

VDC has the characteristic as described here. This is not a device that helps reckless driving.

INPUT SIGNAL AND OUTPUT SIGNAL

Major signal transmission between each unit via communication lines is shown in the following table.

Component	Signal description
Yaw rate/side/decel G sensor	Mainly transmits the following signals to ABS actuator and electric unit (control unit) via communication line*1: <ul style="list-style-type: none"> Yaw rate signal Side G sensor signal Decel G sensor signal
ECM	Mainly transmits the following signals to ABS actuator and electric unit (control unit) via CAN communication: <ul style="list-style-type: none"> Acceleration pedal position signal Engine speed signal Mainly receives the following signal from ABS actuator and electric unit (control unit) via CAN communication: <ul style="list-style-type: none"> Target throttle position signal
TCM	Mainly transmits the following signal to ABS actuator and electric unit (control unit) via CAN communication: <ul style="list-style-type: none"> Shift position signal
Steering angle sensor	Mainly transmits the following signal to ABS actuator and electric unit (control unit) via CAN communication: <ul style="list-style-type: none"> Steering angle sensor signal
Combination meter	Mainly transmits the following signals to ABS actuator and electric unit (control unit) via CAN communication: <ul style="list-style-type: none"> Brake fluid level switch signal Parking brake switch signal Mainly receives the following signals from ABS actuator and electric unit (control unit) via CAN communication: <ul style="list-style-type: none"> VDC warning lamp signal VDC OFF indicator lamp signal

*1: Communication line between yaw rate/side/decel G sensor and ABS actuator and electric unit (control unit)

OPERATION CHARACTERISTICS

VDC Function That Prevents Oversteer Tendency

- During a cornering, brake force (brake fluid pressure) is applied on front wheel and rear wheel on the outer side of turn. Momentum directing towards the outer side of turn is generated. Oversteer is prevented.

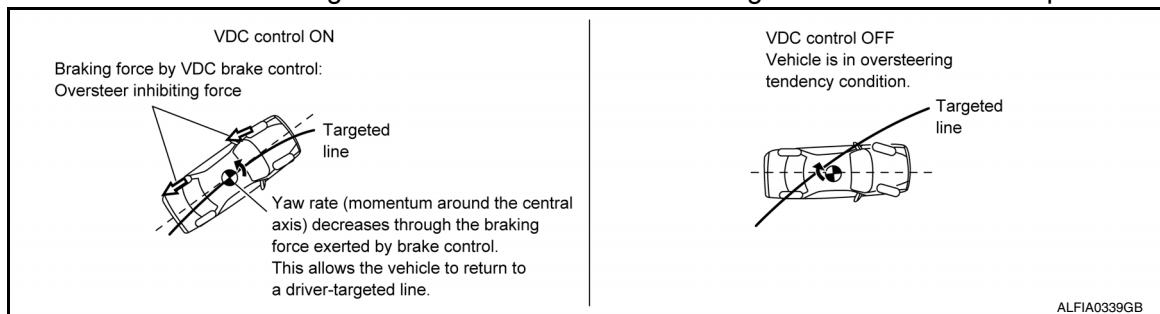

SYSTEM

< SYSTEM DESCRIPTION >

[VDC/TCS/ABS]

- Changing driving lane on a slippery road, when oversteer tendency is judged large, engine output is controlled as well as brake force (brake fluid pressure) of 4 wheels. Oversteer tendency decreases.

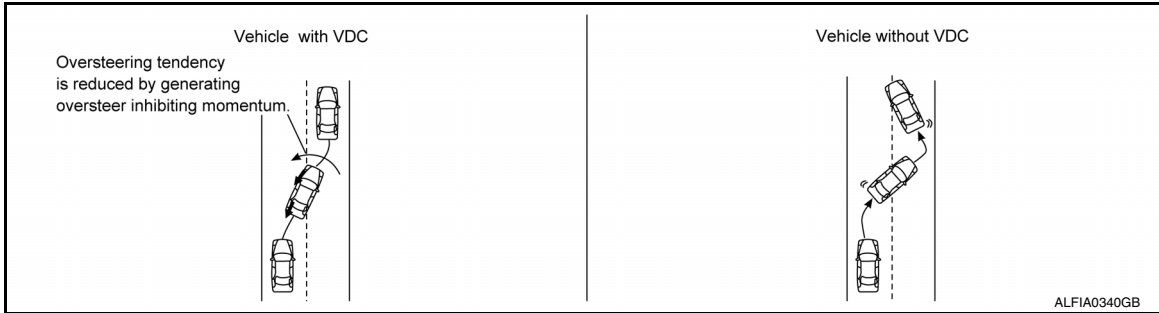

VDC Function That Prevents Understeer Tendency

- During a cornering, brake force (brake fluid pressure) is applied on front wheel and rear wheel on the inner side of turn. Momentum directing towards the inner side of turn is generated. Understeer is prevented.

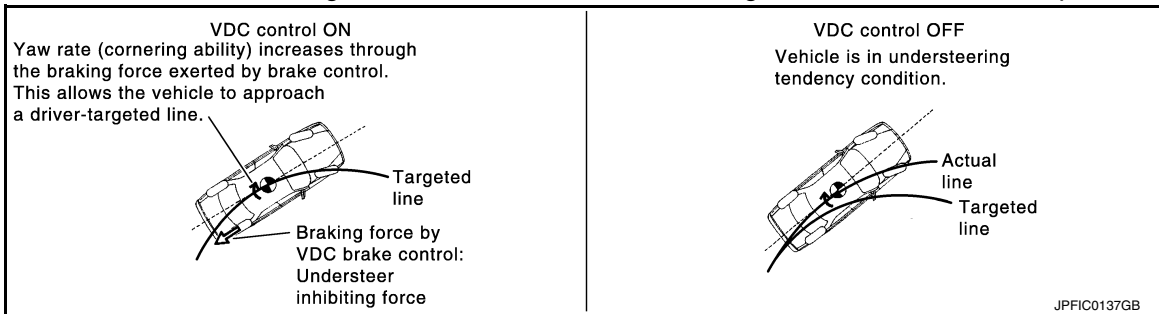

- Applying braking during cornering on a slippery road, when understeer tendency is judged large, engine output is controlled as well as brake force (brake fluid pressure) of four wheels. Understeer tendency decreases.

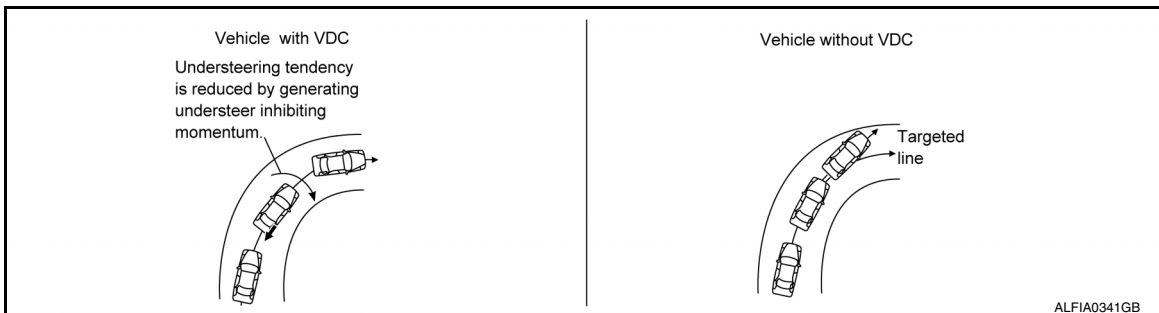

TCS FUNCTION

TCS FUNCTION : System Diagram

INFOID:000000009177249

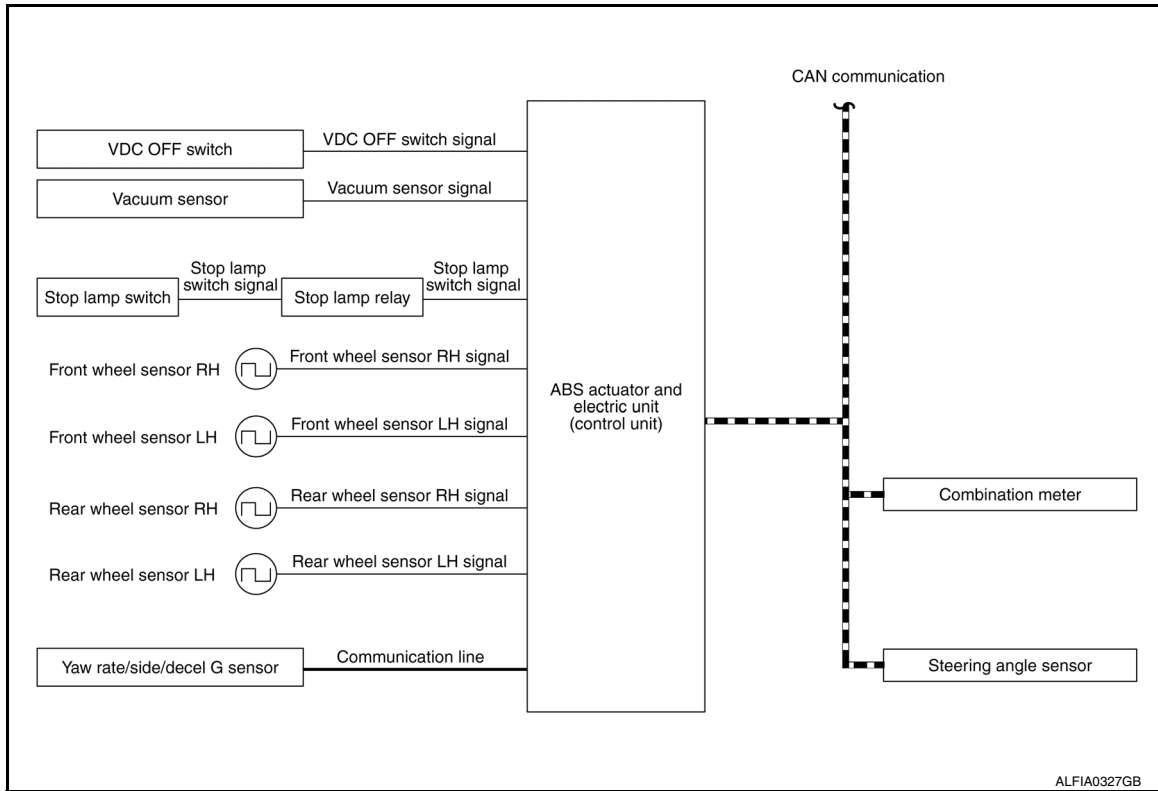

A
B
C
D
E
G
H
I

BRC

TCS FUNCTION : System Description

INFOID:000000009177250

- Wheel spin status of drive wheel is detected by wheel sensor of 4 wheels. Engine output and transmission shift status is controlled so that slip rate of drive wheels is at an appropriate level. When wheel spin occurs on drive wheel, ABS actuator and electric unit (control unit) perform brake force control of LH and RH drive wheels (apply brake force by increasing brake fluid pressure of drive wheel) and decrease engine torque by engine torque control. Wheel spin amount decreases. Engine torque is controlled to appropriate level.
- TCS function can be switched to non-operational status (OFF) by operating VDC OFF switch. In this case, VDC OFF indicator lamp turns ON.
- VDC warning lamp blinks while TCS function is in operation and indicates to the driver that the function is in operation.
- CONSULT can be used to diagnose the system.
- Fail-safe function is adopted. When a malfunction occurs in TCS function, the control is suspended for VDC function, TCS function, and hill start assist function. The vehicle status becomes the same as models without VDC function, TCS function and hill start assist function. However, ABS function and EBD function are operated normally. Refer to [BRC-19, "Fail-Safe"](#).

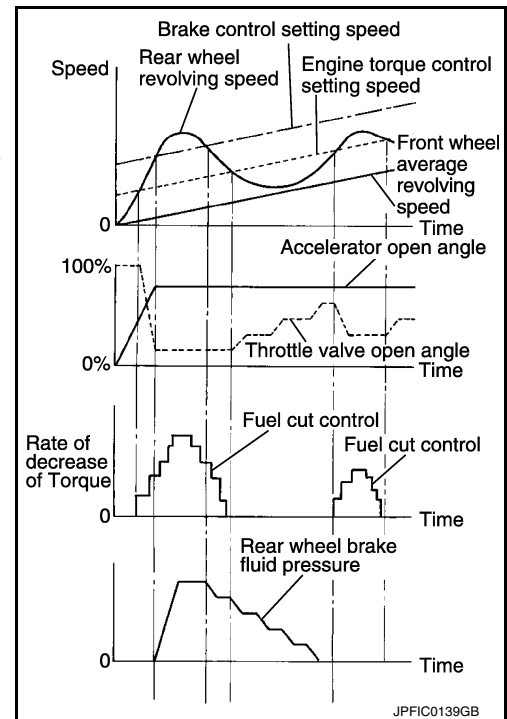

J
K
L
M
N
O
P

INPUT SIGNAL AND OUTPUT SIGNAL

Major signal transmission between each unit via communication lines is shown in the following table.

SYSTEM

< SYSTEM DESCRIPTION >

[VDC/TCS/ABS]

Component	Signal description
Yaw rate/side/decel G sensor	Mainly transmits the following signals to ABS actuator and electric unit (control unit) via communication line*1: <ul style="list-style-type: none"> • Yaw rate signal • Side G sensor signal • Decel G sensor signal
ECM	Mainly transmits the following signals to ABS actuator and electric unit (control unit) via CAN communication: <ul style="list-style-type: none"> • Accelerator pedal position signal • Engine speed signal Mainly receives the following signal from ABS actuator and electric unit (control unit) via CAN communication: <ul style="list-style-type: none"> • Target throttle position signal
TCM	Mainly transmits the following signal to ABS actuator and electric unit (control unit) via CAN communication: <ul style="list-style-type: none"> • Shift position signal
Steering angle sensor	Mainly transmits the following signal to ABS actuator and electric unit (control unit) via CAN communication: <ul style="list-style-type: none"> • Steering angle sensor signal
Combination meter	Mainly transmits the following signals to ABS actuator and electric unit (control unit) via CAN communication: <ul style="list-style-type: none"> • Brake fluid level switch signal • Parking brake switch signal Mainly receives the following signals from ABS actuator and electric unit (control unit) via CAN communication: <ul style="list-style-type: none"> • VDC warning lamp signal • VDC OFF indicator lamp signal

*1: Communication line between yaw rate/side/decel G sensor and ABS actuator and electric unit (control unit)
ABS FUNCTION

ABS FUNCTION : System Diagram

INFOID:000000009177251

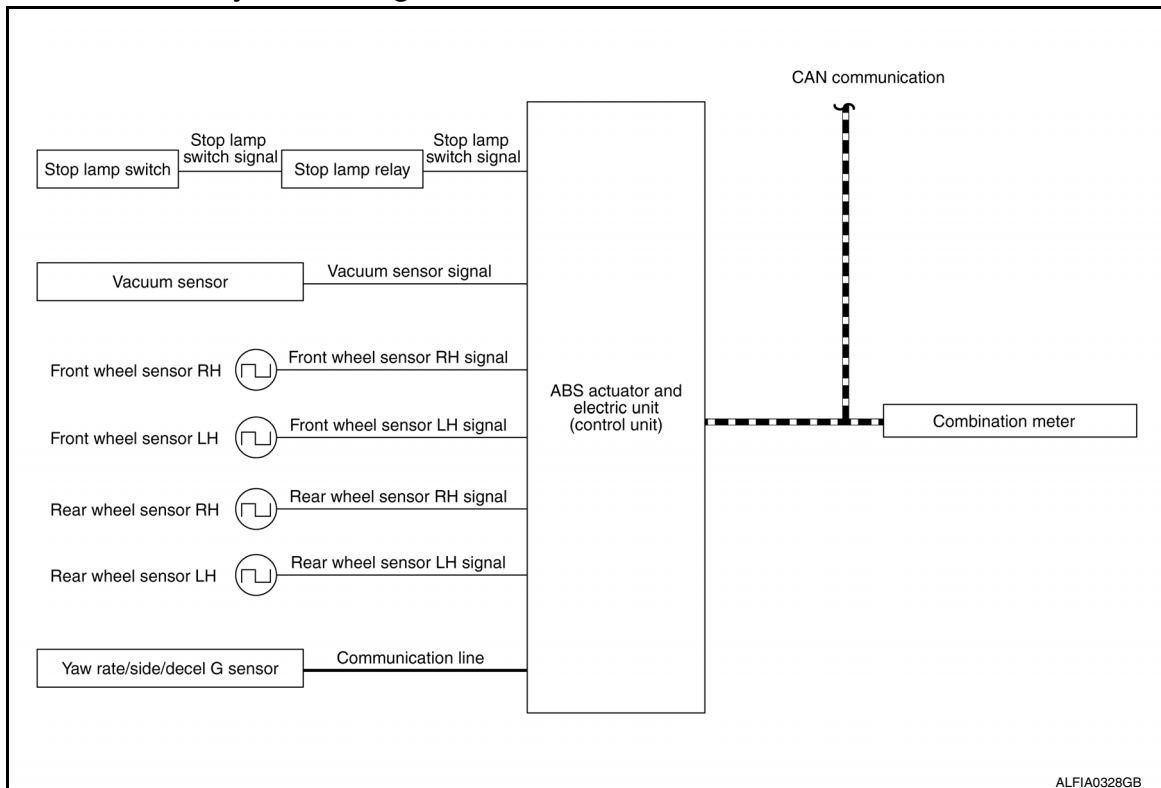

ABS FUNCTION : System Description

- By preventing wheel lock through brake force (brake fluid pressure) control that is electronically controlled by detecting wheel speed during braking, stability during emergency braking is improved so that obstacles can be avoided by steering operation.
- During braking, control unit calculates wheel speed and pseudo-vehicle speed, and transmits pressure increase, hold or decrease signals to actuator portion according to wheel slip status.
- The following effects are obtained by preventing wheel lock during braking.
 - Vehicle tail slip is prevented during braking when driving straight.
 - Understeer and oversteer tendencies are moderated during braking driving on a corner.
 - Obstacles may be easily bypassed by steering operation during braking.
- CONSULT can be used to diagnose the system diagnosis.
- Fail-safe function is adopted. When a malfunction occurs in ABS function, the control is suspended for VDC function, TCS function, ABS function and hill start assist function. The vehicle status becomes the same as models without VDC function, TCS function, ABS function and hill start assist function. However, EBD function is operated normally. Refer to [BRC-19. "Fail-Safe"](#).

NOTE:

- ABS has the characteristic as described here. This is not the device that helps reckless driving.
- To stop vehicle efficiently, ABS does not operate and ordinary brake operates at low speed [approx. 10 km/h (6 MPH) or less but differs subject to road conditions].
- Self-diagnosis is performed immediately after when engine starts and when vehicle initially is driven [by vehicle speed approx. 15 km/h (9 MPH)]. Motor sounds are generated during self-diagnosis. In addition, brake pedal may feel heavy when depressing brake pedal lightly. These symptoms are not malfunctions.

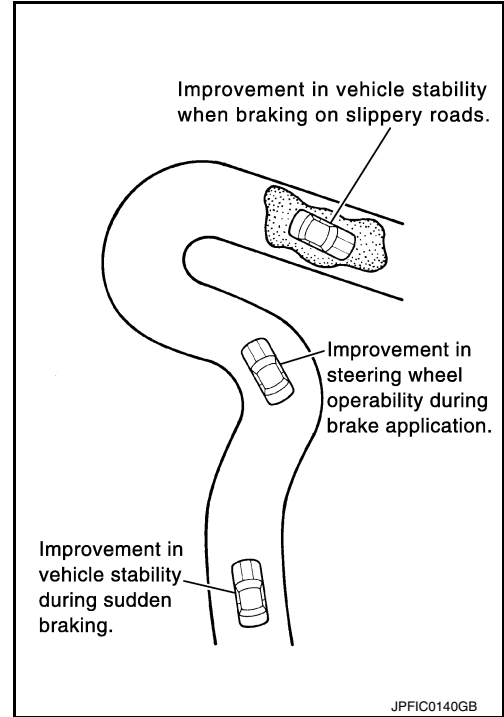

INPUT SIGNAL AND OUTPUT SIGNAL

Major signal transmission between each unit via communication lines is shown in the following table.

Component	Signal description
Steering angle sensor	Mainly transmits the following signals to ABS actuator and electric unit (control unit) via CAN communication: <ul style="list-style-type: none"> • Steering angle sensor signal
Combination meter	Mainly receives the following signals from ABS actuator and electric unit (control unit) via CAN communication: <ul style="list-style-type: none"> • ABS warning lamp signal • VDC warning lamp signal

EBD FUNCTION

A
B
C
D
E
BRC
G
H
I
J
K
L
M
N
O
P

EBD FUNCTION : System Diagram

INFOID:000000009177253

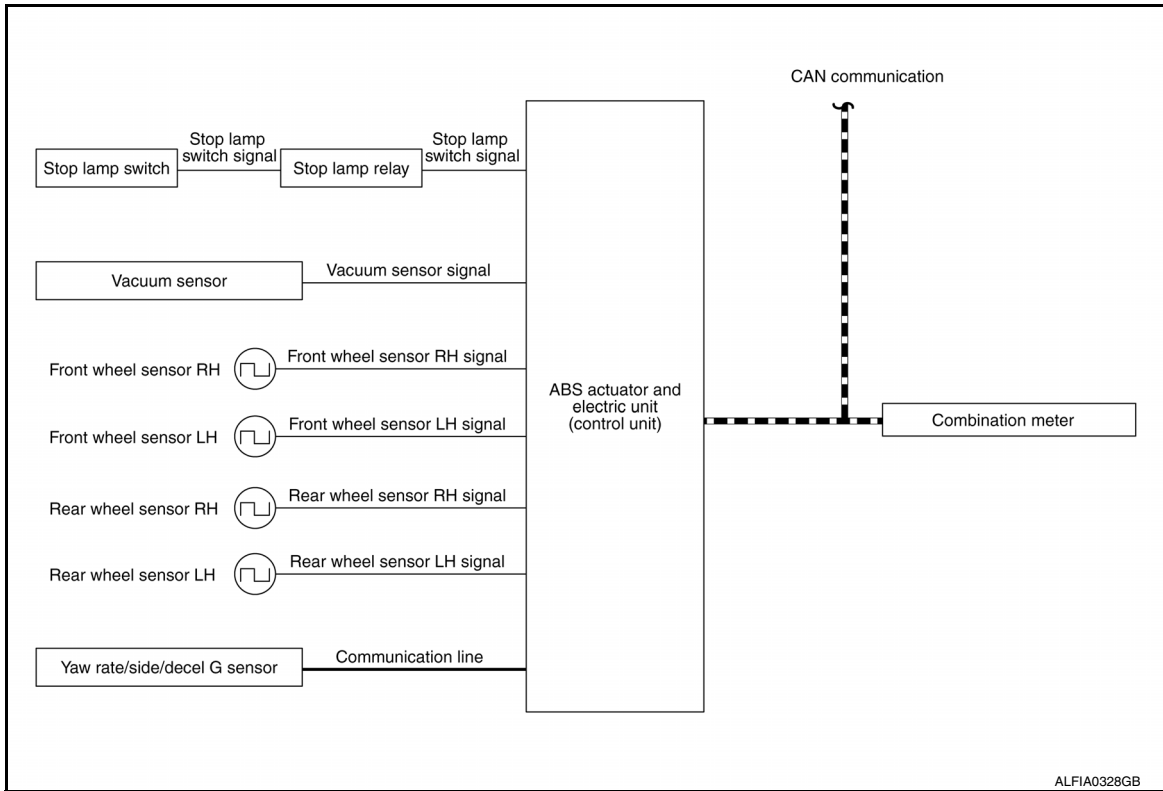

EBD FUNCTION : System Description

INFOID:000000009177254

- By preventing rear wheel slip increase through rear wheel brake force (brake fluid pressure) control that is electronically controlled when slight skip on front and rear wheels are detected during braking, stability during braking is improved.
- EBD function is expanded and developed from conventional ABS function and corrects rear wheel brake force to appropriate level by electronic control according to load weight (number of passengers).

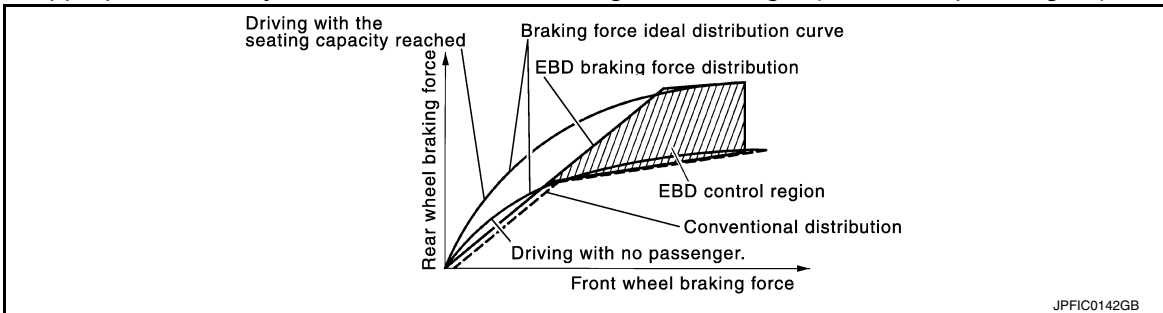

SYSTEM

[VDC/TCS/ABS]

< SYSTEM DESCRIPTION >

- During braking, control unit portion compares slight slip on front and rear wheels by wheel speed sensor signal, transmits drive signal to actuator portion when rear wheel slip exceeds front wheel slip for the specified value or more, and controls rear wheel brake force (brake fluid pressure) so that increase of rear wheel slip is prevented and slips on front wheel and rear wheel are nearly equalized. ABS control is applied when slip on each wheel increases and wheel speed is the threshold value of ABS control or less.
- CONSULT can be used to diagnose the system.
- Fail-safe function is adopted. When a malfunction occurs in EBD function, the control is suspended for VDC function, TCS function, ABS function, EBD function and hill start assist function. The vehicle status becomes the same as models without VDC function, TCS function, ABS function, EBD function and hill start assist function. Refer to [BRC-19. "Fail-Safe"](#).

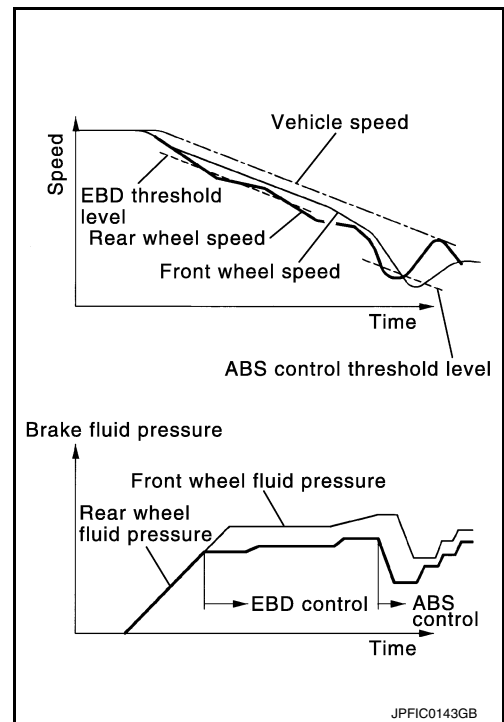

INPUT SIGNAL AND OUTPUT SIGNAL

Major signal transmission between each unit via communication lines is shown in the following table.

Component	Signal description
Combination meter	Mainly receives the following signals from ABS actuator and electric unit (control unit) via CAN communication: <ul style="list-style-type: none"> • Brake warning lamp signal • ABS warning lamp signal • VDC warning lamp signal

Hill start assist FUNCTION

A
B
C
D
E
BRC
G
H
I
J
K
L
M
N
O
P

Hill start assist FUNCTION : System Diagram

INFOID:000000009177255

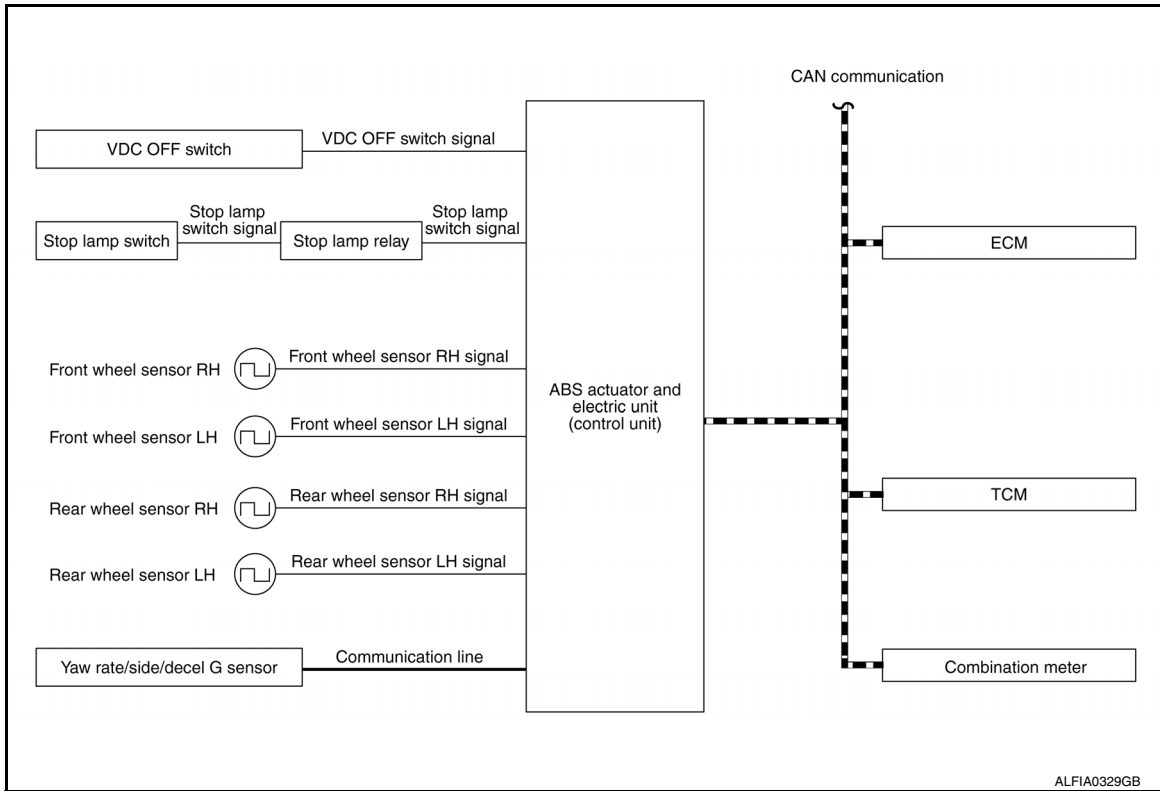

ALFIA0329GB

Hill start assist FUNCTION : System Description

INFOID:000000009177256

- This function maintains brake fluid pressure so that the vehicle does not move backwards, even if brake pedal is released to depress accelerator pedal to start the vehicle, while it is stopped on an uphill slope by depressing brake pedal.
- This function operates when the vehicle is in stop status on an uphill slope of slope ratio 10% or more and selector lever is in any position other than P (Park) or N (Neutral).
- Hill start assist function is only for the start aid. It maintains the brake fluid pressure for approx. 2 seconds after releasing the brake pedal, and then decreases the pressure gradually. If the vehicle starts by accelerator operation, the brake is released automatically and a smooth start is performed.
- Fail-safe function is adopted. When a malfunction occurs in hill start assist function, the control is suspended for VDC function, TCS function and hill start assist function. The vehicle status becomes the same as models without VDC function, TCS function and hill start assist function. However, ABS function and EBD function are operated normally. Refer to [BRC-19, "Fail-Safe"](#).

INPUT SIGNAL AND OUTPUT SIGNAL

Major signal transmission between each unit via communication lines is shown in the following table.

Component	Signal description
Yaw rate/side/decel G sensor	Mainly transmits the following signals to ABS actuator and electric unit (control unit) via communication line *: <ul style="list-style-type: none"> • Yaw rate signal • Side G sensor signal • Decel G sensor signal
ECM	Mainly transmits the following signals to ABS actuator and electric unit (control unit) via CAN communication: <ul style="list-style-type: none"> • Accelerator pedal position signal • Engine speed signal Mainly receives the following signal from ABS actuator and electric unit (control unit) via CAN communication: <ul style="list-style-type: none"> • Target throttle position signal

SYSTEM

< SYSTEM DESCRIPTION >

[VDC/TCS/ABS]

Component	Signal description	A
TCM	Mainly transmits the following signal to ABS actuator and electric unit (control unit) via CAN communication: <ul style="list-style-type: none">• Shift position signal	B
Combination meter	Mainly transmits the following signals to ABS actuator and electric unit (control unit) via CAN communication: <ul style="list-style-type: none">• Brake fluid level switch signal• Parking brake switch signal Mainly receives the following signals from ABS actuator and electric unit (control unit) via CAN communication: <ul style="list-style-type: none">• VDC warning lamp signal• VDC OFF indicator lamp signal	C

*: Communication line between yaw rate/side/decel G sensor and ABS actuator and electric unit (control unit)

D

E

BRC

G

H

I

J

K

L

M

N

O

P

DIAGNOSIS SYSTEM [ABS ACTUATOR AND ELECTRIC UNIT (CONTROL UNIT)]

< SYSTEM DESCRIPTION >

[VDC/TCS/ABS]

DIAGNOSIS SYSTEM [ABS ACTUATOR AND ELECTRIC UNIT (CONTROL UNIT)]

CONSULT Function

INFOID:000000009177257

CAUTION:

After disconnecting the CONSULT vehicle interface (VI) from the data link connector, the ignition must be cycled OFF → ON (for at least 5 seconds) → OFF. If this step is not performed, the BCM may not go to "sleep mode", potentially causing a discharged battery and a no-start condition.

APPLICATION ITEMS

CONSULT can display each diagnostic item using the diagnostic test modes as follows.

Mode	Function description
ECU identification	Parts number of ABS actuator and electric unit (control unit) can be read.
Self Diagnostic Result	Self-diagnostic results and freeze frame data can be read and erased quickly.*
DATA MONITOR	Input/Output data in the ABS actuator and electric unit (control unit) can be read.
ACTIVE TEST	Diagnostic Test Mode in which CONSULT drives some actuators apart from the ABS actuator and electric unit (control unit) and also shifts some parameters in a specified range.
WORK SUPPORT	Components can be quickly and accurately adjusted.

*: The following diagnosis information is erased by erasing.

- DTC
- Freeze frame data (FFD)

ECU IDENTIFICATION

ABS actuator and electric unit (control unit) part number can be read.

SELF DIAGNOSTIC RESULT

Refer to [BRC-42. "DTC Index"](#).

When "CRNT" is displayed on self-diagnosis result,

- The system is presently malfunctioning.

When "PAST" is displayed on self-diagnosis result,

- System malfunction in the past is detected, but the system is presently normal.

Freeze frame data (FFD)

The following vehicle status is recorded when DTC is detected and is displayed on CONSULT.

Item name	Display item
IGN counter (0 – 39)	<p>The number of times that ignition switch is turned ON after the DTC is detected is displayed.</p> <ul style="list-style-type: none">• When "0" is displayed: It indicates that the system is presently malfunctioning.• When except "0" is displayed: It indicates that system malfunction in the past is detected, but the system is presently normal. <p>NOTE: Each time when ignition switch is turned OFF to ON, numerical number increases in 1 → 2 → 3...38 → 39. When the operation number of times exceeds 39, the number do not increase and "39" is displayed until self-diagnosis is erased.</p>

ACTIVE TEST

The active test is used to determine and identify details of a malfunction, based on self-diagnosis test results and data obtained in the DATA MONITOR. In response to instructions from CONSULT, instead of those from ABS actuator and electric unit (control unit) on the vehicle, a drive signal is sent to the actuator to check its operation.

CAUTION:

- Never perform ACTIVE TEST while driving the vehicle.
- Always bleed air from brake system before active test.
- Never perform active test when system is malfunctioning.

NOTE:

DIAGNOSIS SYSTEM [ABS ACTUATOR AND ELECTRIC UNIT (CONTROL UNIT)]

< SYSTEM DESCRIPTION >

[VDC/TCS/ABS]

- When active test is performed while depressing the pedal, the pedal depressing stroke may change. This is not a malfunction.
- “TEST IS STOPPED” is displayed approx. 10 seconds after operation start.
- When performing active test again after “TEST IS STOPPED” is displayed, select “BACK”.
- ABS warning lamp, brake warning lamp and VDC warning lamp may turn ON during active test. This is not a malfunction.

ABS IN Valve and ABS OUT Valve

When “Up”, “Keep” or “Down” is selected on display screen, the following items are displayed when system is normal.

Test item	Display Item	Display		
		Up	Keep	Down
FR RH SOL	FR RH IN SOL	Off	On*	On*
	FR RH OUT SOL	Off	Off	On*
FR LH SOL	FR LH IN SOL	Off	On*	On*
	FR LH OUT SOL	Off	Off	On*
RR RH SOL	RR RH IN SOL	Off	On*	On*
	RR RH OUT SOL	Off	Off	On*
RR LH SOL	RR LH IN SOL	Off	On*	On*
	RR LH OUT SOL	Off	Off	On*

*: Immediately after being selected, status is “On”. Status changes to “Off” after approx. 2 seconds.

ABS IN Valve (ACT) and ABS OUT Valve (ACT)

When “Up”, “ACT UP” or “ACT KEEP” is selected on display screen, the following items are displayed when system is normal.

Test item	Display Item	Display		
		Up	ACT UP	ACT KEEP
FR RH ABS SOLE-NOID (ACT)	FR RH IN SOL	Off	Off	Off
	FR RH OUT SOL	Off	Off	Off
	CV1	Off	Off	Off
	CV2	Off	On*	On*
FR LH ABS SOLE-NOID (ACT)	FR LH IN SOL	Off	Off	Off
	FR LH OUT SOL	Off	Off	Off
	CV1	Off	On*	On*
	CV2	Off	Off	Off
RR RH ABS SOLE-NOID (ACT)	RR RH IN SOL	Off	Off	Off
	RR RH OUT SOL	Off	Off	Off
	CV1	Off	On*	On*
	CV2	Off	Off	Off
RR LH ABS SOLE-NOID (ACT)	RR LH IN SOL	Off	On*	Off
	RR LH OUT SOL	Off	Off	Off
	CV1	Off	Off	Off
	CV2	Off	On*	On*

*: Immediately after being selected, status is “On”. Status changes to “Off” after approx. 10 seconds.

ABS MOTOR

When “On” or “Off” is selected on display screen, the following items are displayed when system is normal.

DIAGNOSIS SYSTEM [ABS ACTUATOR AND ELECTRIC UNIT (CONTROL UNIT)]

< SYSTEM DESCRIPTION >

[VDC/TCS/ABS]

Test item	Display Item	Display	
		On	Off
ABS MOTOR	MOTOR RELAY	On	Off
	ACTUATOR RLY ^(Note)	On	On

NOTE:

Display occasionally changes On/Off for a moment after ignition switch is turned ON. This is an operation for checking purposes and is not a malfunction.

DATA MONITOR

×: Applicable

Item (Unit)	Monitor item selection		Note
	ECU INPUT SIGNALS	MAIN SIGNALS	
FR LH SENSOR [km/h (MPH)]	×	×	Wheel speed calculated by front LH wheel sensor is displayed.
FR RH SENSOR [km/h (MPH)]	×	×	Wheel speed calculated by front RH wheel sensor is displayed.
RR LH SENSOR [km/h (MPH)]	×	×	Wheel speed calculated by rear LH wheel sensor is displayed.
RR RH SENSOR [km/h (MPH)]	×	×	Wheel speed calculated by rear RH wheel sensor is displayed.
DECEL G-SEN (m/s ²)	×	×	Decel G detected by decel G sensor is displayed.
FR RH IN SOL (On/Off)		×	Operation status of front RH wheel ABS IN valve is displayed.
FR RH OUT SOL (On/Off)		×	Operation status of front RH wheel ABS OUT valve is displayed.
FR LH IN SOL (On/Off)		×	Operation status of front LH wheel ABS IN valve is displayed.
FR LH OUT SOL (On/Off)		×	Operation status of front LH wheel ABS OUT valve is displayed.
RR RH IN SOL (On/Off)		×	Operation status of rear RH wheel ABS IN valve is displayed.
RR RH OUT SOL (On/Off)		×	Operation status of rear RH wheel ABS OUT valve is displayed.
RR LH IN SOL (On/Off)		×	Operation status of rear LH wheel ABS IN valve is displayed.
RR LH OUT SOL (On/Off)		×	Operation status of rear LH wheel ABS OUT valve is displayed.
EBD WARN LAMP (On/Off)			Brake warning lamp ON/OFF status is displayed. ^(Note 1)
STOP LAMP SW (On/Off)	×	×	Stop lamp switch signal input status is displayed.
MOTOR RELAY (On/Off)		×	ABS motor and motor relay status is displayed.
ACTUATOR RLY (On/Off)		×	ABS actuator relay status is displayed.
ABS WARN LAMP (On/Off)		×	ABS warning lamp ON/OFF status is displayed. ^(Note 1)
OFF LAMP (On/Off)		×	VDC OFF indicator lamp ON/OFF status is displayed. ^(Note 1)
OFF SW	×	×	VDC OFF switch status is displayed

DIAGNOSIS SYSTEM [ABS ACTUATOR AND ELECTRIC UNIT (CONTROL UNIT)]

< SYSTEM DESCRIPTION >

[VDC/TCS/ABS]

Item (Unit)	Monitor item selection		Note	
	ECU INPUT SIGNALS	MAIN SIGNALS		
SLIP/VDC LAMP (On/Off)		×	VDC warning lamp ON/OFF status is displayed. ^(Note 1)	A
BATTERY VOLT (V)	×	×	Voltage supplied to ABS actuator and electric unit (control unit) is displayed.	B
GEAR	×	×	Current gear position judged from current gear position signal is displayed.	C
SLCT LVR POSI	×	×	Current gear position judged from current gear position signal is displayed.	D
ENGINE SPEED (tr/min)	×	×	Engine speed status is displayed.	E
YAW RATE SEN (d/s)	×	×	Yaw rate detected by yaw rate sensor is displayed.	E
R POSI SIG (On/Off)			R range signal input status judged from R range signal is displayed.	BRC
4WD MODE MON ^(Note 2) (AUTO/2WD/LOCK)	×	×	4WD control status is displayed.	
N POSI SIG (On/Off)			N range signal input status judged from N range signal is displayed.	G
CV1 (On/Off)			Cut valve 1 operation status is displayed.	H
CV2 (On/Off)			Cut valve 2 operation status is displayed.	
ACCEL POS SIG (%)	×		Displays the Accelerator pedal position.	I
SIDE G -SENSOR (m/s ²)	×		Side G detected by side G sensor is displayed.	J
STR ANGLE SIG (°)	×		Steering angle detected by steering angle sensor is displayed.	K
PRESS SENSOR (bar)	×		Brake fluid pressure detected by pressure sensor is displayed.	K
EBD SIGNAL (On/Off)			EBD operation status is displayed.	L
ABS SIGNAL (On/Off)			ABS operation status is displayed.	
TCS SIGNAL (On/Off)			TCS operation status is displayed.	M
VDC SIGNAL (On/Off)			VDC operation status is displayed.	N
EBD FAIL SIG (On/Off)			EBD fail-safe signal status is displayed.	
ABS FAIL SIG (On/Off)			ABS fail-safe signal status is displayed.	O
TCS FAIL SIG (On/Off)			TCS fail-safe signal status is displayed.	P
VDC FAIL SIG (On/Off)			VDC fail-safe signal status is displayed.	
CRANKING SIG (On/Off)			Cranking status is displayed.	
FLUID LEV SW (On/Off)	×		Brake fluid level signal input status via CAN communication is displayed.	

DIAGNOSIS SYSTEM [ABS ACTUATOR AND ELECTRIC UNIT (CONTROL UNIT)]

< SYSTEM DESCRIPTION >

[VDC/TCS/ABS]

Item (Unit)	Monitor item selection		Note
	ECU INPUT SIGNALS	MAIN SIGNALS	
PARK BRAKE SW (On/Off)	×		Parking brake switch signal input status via CAN communication is displayed.
USS SIG ^(Note 3) (On/Off)			hill start assist operation status is displayed.

Note 1: Refer to [BRC-11. "System Description"](#) for ON/OFF conditions of each warning lamp and indicator lamp.

Note 2: Models with 4WD System.

Note 3: USS means "hill start assist."

WORK SUPPORT

Conditions	Description
ST ANGLE SENSOR ADJUSTMENT	Perform neutral position adjustment of steering angle sensor.
DECEL G SEN CALIBRATION	Perform decel G sensor calibration.

ABS ACTUATOR AND ELECTRIC UNIT (CONTROL UNIT)

< ECU DIAGNOSIS INFORMATION >

[VDC/TCS/ABS]

ECU DIAGNOSIS INFORMATION

ABS ACTUATOR AND ELECTRIC UNIT (CONTROL UNIT)

Reference Value

INFOID:000000009177258

CONSULT DATA MONITOR STANDARD VALUE

Monitor item	Condition	Reference values in normal operation
FR LH SENSOR	Vehicle stopped	0.00 km/h (MPH)
	When driving ^(Note 1)	Nearly matches the speedometer display (within ±10%)
FR RH SENSOR	Vehicle stopped	0.00 km/h (MPH)
	When driving ^(Note 1)	Nearly matches the speedometer display (within ±10%)
RR LH SENSOR	Vehicle stopped	0.00 km/h (MPH)
	When driving ^(Note 1)	Nearly matches the speedometer display (within ±10%)
RR RH SENSOR	Vehicle stopped	0.00 km/h (MPH)
	When driving ^(Note 1)	Nearly matches the speedometer display (within ±10%)
DECEL G-SEN	When stopped	Approx. 0 m/s ²
	During acceleration	Positive value
	During deceleration	Negative value
FR RH IN SOL	Active	On
	Not activated	Off
FR RH OUT SOL	Active	On
	Not activated	Off
FR LH IN SOL	Active	On
	Not activated	Off
FR LH OUT SOL	Active	On
	Not activated	Off
RR RH IN SOL	Active	On
	Not activated	Off
RR RH OUT SOL	Active	On
	Not activated	Off
RR LH IN SOL	Active	On
	Not activated	Off
RR LH OUT SOL	Active	On
	Not activated	Off
EBD WARN LAMP	When brake warning lamp is ON ^(Note 2)	On
	When brake warning lamp is OFF ^(Note 2)	Off
STOP LAMP SW	Brake pedal depressed	On
	Brake pedal not depressed	Off
MOTOR RELAY	Active	On
	Not activated	Off
ACTUATOR RLY	Active	On
	When not operating (in fail-safe mode)	Off

ABS ACTUATOR AND ELECTRIC UNIT (CONTROL UNIT)

< ECU DIAGNOSIS INFORMATION >

[VDC/TCS/ABS]

Monitor item	Condition	Reference values in normal operation
ABS WARN LAMP	When ABS warning lamp is ON ^(Note 2)	On
	When ABS warning lamp is OFF ^(Note 2)	Off
OFF LAMP	When VDC OFF indicator lamp is ON ^(Note 2)	On
	When VDC OFF indicator lamp is OFF ^(Note 2)	Off
OFF SW	When VDC OFF switch is ON	On
	When VDC OFF switch is OFF	Off
SLIP/VDC LAMP	When VDC warning lamp is ON ^(Note 2)	On
	When VDC warning lamp is OFF ^(Note 2)	Off
BATTERY VOLT	Ignition switch ON	10 – 16 V
GEAR	Driving	1 – 7 Depending on shift status
SLCT LVR POSI	Vehicle stopped	N/P Depending on shift status
ENGINE SPEED	Engine stopped	0 tr/min
	Engine running	Almost same reading as tachometer
YAW RATE SEN	Vehicle stopped	Approx. 0 d/s
	Turning right	Negative value
	Turning left	Positive value
R POSI SIG	When selector lever is in the R position	On
	When selector lever is in the other position than R	Off
4WD MODE MON ^(Note 3)	When 4WD shift switch is in AUTO position	AUTO
	When 4WD shift switch is in 4H position	LOCK
	When 4WD shift switch is in 2WD position	2WD
N POSI SIG	When selector lever is in the N position	On
	When selector lever is in the other position than N	Off
CV1	Active	On
	Not activated	Off
CV2	Active	On
	Not activated	Off
ACCEL POS SIG	Never depress accelerator pedal (with ignition switch ON)	0%
	Depress accelerator pedal (with ignition switch ON)	0 – 100%
SIDE G-SENSOR	Vehicle stopped	Approx. 0 m/s ²
	Right turn	Negative value
	Left turn	Positive value
STR ANGLE SIG	When driving straight	0±2.5°
	When steering wheel is steered to LH by 90°	Approx. +90°
	When steering wheel is steered to RH by 90°	Approx. -90°
PRESS SENSOR	Brake pedal not depressed	Approx. 0 bar
	Brake pedal depressed	(-40) – (+300 bar)
EBD SIGNAL	EBD activated	On
	EBD not activated	Off
ABS SIGNAL	ABS is activated	On
	ABS is not activated	Off

ABS ACTUATOR AND ELECTRIC UNIT (CONTROL UNIT)

< ECU DIAGNOSIS INFORMATION >

[VDC/TCS/ABS]

Monitor item	Condition	Reference values in normal operation
TCS SIGNAL	TCS activated	On
	TCS not activated	Off
VDC SIGNAL	VDC activated	On
	VDC not activated	Off
EBD FAIL SIG	In EBD fail-safe	On
	EBD is normal	Off
ABS FAIL SIG	In ABS fail-safe	On
	ABS is normal	Off
TCS FAIL SIG	In TCS fail-safe	On
	TCS is normal	Off
VDC FAIL SIG	In VDC fail-safe	On
	VDC is normal	Off
CRANKING SIG	At cranking	On
	Other than at cranking	Off
FLUID LEV SW	When brake fluid level switch is ON (brake fluid level is less than the specified level)	On
	When brake fluid level switch is OFF	Off
PARK BRAKE SW	When parking brake is active	On
	Parking brake is released	Off
USS SIG ^(Note 4)	hill start assist is active	On
	hill start assist is inactive	Off

Note 1: Confirm tire pressure is standard value.

Note 2: Refer to [BRC-11. "System Description"](#) for ON/OFF conditions of each warning lamp and indicator lamp.

Note 3: Models with 4WD System.

Note 4: USS means "hill start assist."

Fail-Safe

INFOID:000000009177259

VDC FUNCTION, TCS FUNCTION AND hill start assist FUNCTION

VDC warning lamp in combination meter turns ON when a malfunction occurs in the system [ABS actuator and electric unit (control unit)]. The control is suspended for VDC function, TCS function and hill start assist function. The vehicle status becomes the same as models without VDC function, TCS function and hill start assist function. However, ABS function and EBD function are operated normally.

ABS FUNCTION

ABS warning lamp and VDC warning lamp in combination meter turn ON when a malfunction occurs in the system [ABS actuator and electric unit (control unit)]. The control is suspended for VDC function, TCS function, ABS function and hill start assist function. The vehicle status becomes the same as models without VDC function, TCS function, ABS function and hill start assist function. However, EBD function is operated normally.

NOTE:

ABS self-diagnosis sound may be heard the same as in the normal condition because self-diagnosis is performed when ignition switch turns ON and when vehicle initially starts.

EBD FUNCTION

ABS warning lamp, brake warning lamp and VDC warning lamp in combination meter turn ON when a malfunction occurs in the system [ABS actuator and electric unit (control unit)]. The control is suspended for VDC function, TCS function, ABS function, EBD function and hill start assist function. The vehicle status becomes the same as models without VDC function, TCS function, ABS function, EBD function and hill start assist function.

ABS ACTUATOR AND ELECTRIC UNIT (CONTROL UNIT)

< ECU DIAGNOSIS INFORMATION >

[VDC/TCS/ABS]

DTC	Malfunction detected condition	Fail-safe condition
C1101	When an open circuit is detected in rear RH wheel sensor circuit.	<p>The following functions are suspended:</p> <ul style="list-style-type: none"> • VDC function • TCS function • ABS function • EBD function (only when both 2 rear wheels are malfunctioning) • hill start assist function
C1102	When an open circuit is detected in rear LH wheel sensor circuit.	
C1103	When an open circuit is detected in front RH wheel sensor circuit.	
C1104	When an open circuit is detected in front LH wheel sensor circuit.	
C1105	<ul style="list-style-type: none"> • When power supply voltage of rear RH wheel sensor is low. • When distance between rear RH wheel sensor and rear RH wheel sensor rotor is large. • When installation of rear RH wheel sensor or rear RH wheel sensor rotor is not normal. 	
C1106	<ul style="list-style-type: none"> • When power supply voltage of rear LH wheel sensor is low. • When distance between rear LH wheel sensor and rear LH wheel sensor rotor is large. • When installation of rear LH wheel sensor or rear LH wheel sensor rotor is not normal. 	
C1107	<ul style="list-style-type: none"> • When power supply voltage of front RH wheel sensor is low. • When distance between front RH wheel sensor and front RH wheel sensor rotor is large. • When installation of front RH wheel sensor or front RH wheel sensor rotor is not normal. 	
C1108	<ul style="list-style-type: none"> • When power supply voltage of front LH wheel sensor is low. • When distance between front LH wheel sensor and front LH wheel sensor rotor is large. • When installation of front LH wheel sensor or front LH wheel sensor rotor is not normal. 	
C1109	<ul style="list-style-type: none"> • When ignition voltage is 10 V or less. • When ignition voltage is 16 V or more. 	<p>The following functions are suspended:</p> <ul style="list-style-type: none"> • VDC function • TCS function • ABS function • EBD function • hill start assist function
C1111	When a malfunction is detected in motor or motor relay.	<p>The following functions are suspended:</p> <ul style="list-style-type: none"> • VDC function • TCS function • ABS function • EBD function • hill start assist function
C1115	When difference in wheel speed between any wheel and others is detected during the vehicle is driven because of installation of other tires than specified.	<p>The following functions are suspended:</p> <ul style="list-style-type: none"> • VDC function • TCS function • ABS function • hill start assist function
C1116	When stop lamp switch signal is not input when brake pedal operates.	<p>The following functions are suspended:</p> <ul style="list-style-type: none"> • VDC function • TCS function • ABS function • hill start assist function
C1120	When a malfunction is detected in front LH ABS IN valve.	<p>The following functions are suspended:</p> <ul style="list-style-type: none"> • VDC function • TCS function • ABS function • EBD function • hill start assist function
C1121	When a malfunction is detected in front LH ABS OUT valve.	
C1122	When a malfunction is detected in front RH ABS IN valve.	
C1123	When a malfunction is detected in front RH ABS OUT valve.	
C1124	When a malfunction is detected in rear LH ABS IN valve.	
C1125	When a malfunction is detected in rear LH ABS OUT valve.	
C1126	When a malfunction is detected in rear RH ABS IN valve.	
C1127	When a malfunction is detected in rear RH ABS OUT valve.	
C1130	When a malfunction is detected in ECM system.	<p>The following functions are suspended:</p> <ul style="list-style-type: none"> • VDC function • TCS function • hill start assist function

ABS ACTUATOR AND ELECTRIC UNIT (CONTROL UNIT)

< ECU DIAGNOSIS INFORMATION >

[VDC/TCS/ABS]

DTC	Malfunction detected condition	Fail-safe condition
C1140	When a malfunction is detected in actuator relay.	The following functions are suspended: <ul style="list-style-type: none"> • VDC function • TCS function • ABS function • EBD function • hill start assist function
C1142	When a malfunction is detected in pressure sensor.	The following functions are suspended: <ul style="list-style-type: none"> • VDC function • TCS function • hill start assist function
C1143	When a malfunction is detected in steering angle sensor.	
C1144	When neutral position adjustment of steering angle sensor is not complete.	
C1145	When a malfunction is detected in yaw rate signal.	
C1146	When a malfunction is detected in side/decel G signal.	
C1155	When brake fluid level low signal is detected.	The following functions are suspended: <ul style="list-style-type: none"> • VDC function • TCS function • ABS function • hill start assist function
C1160	When calibration of yaw rate/side/decel G sensor is not complete.	The following functions are suspended: <ul style="list-style-type: none"> • VDC function • TCS function • hill start assist function
C1164	When a malfunction is detected in cut valve 1.	The following functions are suspended: <ul style="list-style-type: none"> • VDC function • TCS function • ABS function • EBD function • hill start assist function
C1165	When a malfunction is detected in cut valve 2.	
C1170	When the information in ABS actuator and electric unit (control unit) is not the same.	The following functions are suspended: <ul style="list-style-type: none"> • VDC function • TCS function • ABS function • EBD function • hill start assist function
C1197	When a malfunction is detected in vacuum sensor.	Electrical vacuum assistance of brake booster is suspended.
C1198	<ul style="list-style-type: none"> • When an open circuit is detected in vacuum sensor circuit. • When a short circuit is detected in vacuum sensor circuit. • When a malfunction is detected in vacuum sensor noise. 	
C1199	When brake booster vacuum is approx. 0 kPa (0 mmHg) during engine running.	
C119A	When a malfunction is detected in supply power voltage of vacuum sensor.	Electrical vacuum assistance of brake booster is suspended.
U1000	When CAN communication signal is not continuously received for 2 seconds or more.	The following functions are suspended: <ul style="list-style-type: none"> • VDC function • TCS function • hill start assist function

A
B
C
D
E
G
H
I
J
K
L
M

BRC

DTC Inspection Priority Chart

INFOID:000000009177260

When multiple DTCs are displayed simultaneously, check one by one depending on the following priority list.

Priority	Detected item (DTC)
1	<ul style="list-style-type: none"> • U1000 CAN COMM CIRCUIT
2	<ul style="list-style-type: none"> • C1170 VARIANT CODING
3	<ul style="list-style-type: none"> • C1130 ENGINE SIGNAL 1 • C1144 ST ANG SEN SIGNAL
4	<ul style="list-style-type: none"> • C1109 BATTERY VOLTAGE [ABNOMAL] • C1111 PUMP MOTOR • C1140 ACTUATOR RLY

N
O
P

ABS ACTUATOR AND ELECTRIC UNIT (CONTROL UNIT)

< ECU DIAGNOSIS INFORMATION >

[VDC/TCS/ABS]

Priority	Detected item (DTC)
5	<ul style="list-style-type: none"> • C1101 RR RH SENSOR-1 • C1102 RR LH SENSOR-1 • C1103 FR RH SENSOR-1 • C1104 FR LH SENSOR-1 • C1105 RR RH SENSOR-2 • C1106 RR LH SENSOR-2 • C1107 FR RH SENSOR-2 • C1108 FR LH SENSOR-2 • C1115 ABS SENSOR [ABNORMAL SIGNAL] • C1116 STOP LAMP SW • C1120 FR LH IN ABS SOL • C1121 FR LH OUT ABS SOL • C1122 FR RH IN ABS SOL • C1123 FR RH OUT ABS SOL • C1124 RR LH IN ABS SOL • C1125 RR LH OUT ABS SOL • C1126 RR RH IN ABS SOL • C1127 RR RH OUT ABS SOL • C1142 PRESS SEN CIRCUIT • C1143 ST ANG SEN CIRCUIT • C1145 YAW RATE SENSOR • C1146 SIDE G SEN CIRCUIT • C1160 DECEL G SEN SET • C1164 CV 1 • C1165 CV 2 • C1197 VACUUM SENSOR • C1198 VACUUM SEN CIR • C1199 BRAKE BOOSTER • C119A VACUUM SEN VOLT
6	<ul style="list-style-type: none"> • C1155 BR FLUID LEVEL LOW

DTC Index

INFOID:000000009177261

DTC	Display Item	Refer to
C1101	RR RH SENSOR-1	BRC-59, "DTC Logic"
C1102	RR LH SENSOR-1	
C1103	FR RH SENSOR-1	
C1104	FR LH SENSOR-1	
C1105	RR RH SENSOR-2	BRC-63, "DTC Logic"
C1106	RR LH SENSOR-2	
C1107	FR RH SENSOR-2	
C1108	FR LH SENSOR-2	
C1109	BATTERY VOLTAGE [ABNOMAL]	BRC-65, "DTC Logic"
C1111	PUMP MOTOR	BRC-67, "DTC Logic"
C1115	ABS SENSOR [ABNORMAL SIGNAL]	BRC-69, "DTC Logic"
C1116	STOP LAMP SW	BRC-71, "DTC Logic"
C1120	FR LH IN ABS SOL	BRC-73, "DTC Logic"
C1121	FR LH OUT ABS SOL	BRC-75, "DTC Logic"
C1122	FR RH IN ABS SOL	BRC-73, "DTC Logic"
C1123	FR RH OUT ABS SOL	BRC-75, "DTC Logic"
C1124	RR LH IN ABS SOL	BRC-73, "DTC Logic"
C1125	RR LH OUT ABS SOL	BRC-75, "DTC Logic"
C1126	RR RH IN ABS SOL	BRC-73, "DTC Logic"
C1127	RR RH OUT ABS SOL	BRC-75, "DTC Logic"

ABS ACTUATOR AND ELECTRIC UNIT (CONTROL UNIT)

< ECU DIAGNOSIS INFORMATION >

[VDC/TCS/ABS]

DTC	Display Item	Refer to	
C1130	ENGINE SIGNAL 1	BRC-77, "DTC Logic"	A
C1140	ACTUATOR RLY	BRC-78, "DTC Logic"	
C1142	PRESS SEN CIRCUIT	BRC-80, "DTC Logic"	B
C1143	ST ANG SEN CIRCUIT	BRC-82, "DTC Logic"	
C1144	ST ANG SEN SIGNAL	BRC-84, "DTC Logic"	
C1145	YAW RATE SENSOR	BRC-85, "DTC Logic"	C
C1146	SIDE G SEN CIRCUIT		
C1155	BR FLUID LEVEL LOW	BRC-88, "DTC Logic"	D
C1160	DECEL G SEN SET	BRC-90, "DTC Logic"	
C1164	CV 1	BRC-91, "DTC Logic"	E
C1165	CV 2		
C1170	VARIANT CODING	BRC-93, "DTC Logic"	
C1197	VACUUM SENSOR	BRC-94, "DTC Logic"	BRC
C1198	VACUUM SEN CIR	BRC-96, "DTC Logic"	
C1199	BRAKE BOOSTER	BRC-98, "DTC Logic"	
C119A	VACUUM SEN VOLT	BRC-100, "DTC Logic"	G
U1000	CAN COMM CIRCUIT	BRC-102, "DTC Logic"	

H
I
J
K
L
M
N
O
P

BRAKE CONTROL SYSTEM

[VDC/TCS/ABS]

< WIRING DIAGRAM >

WIRING DIAGRAM

BRAKE CONTROL SYSTEM

Wiring Diagram

INFOID:000000009177262

BRAKE CONTROL SYSTEM

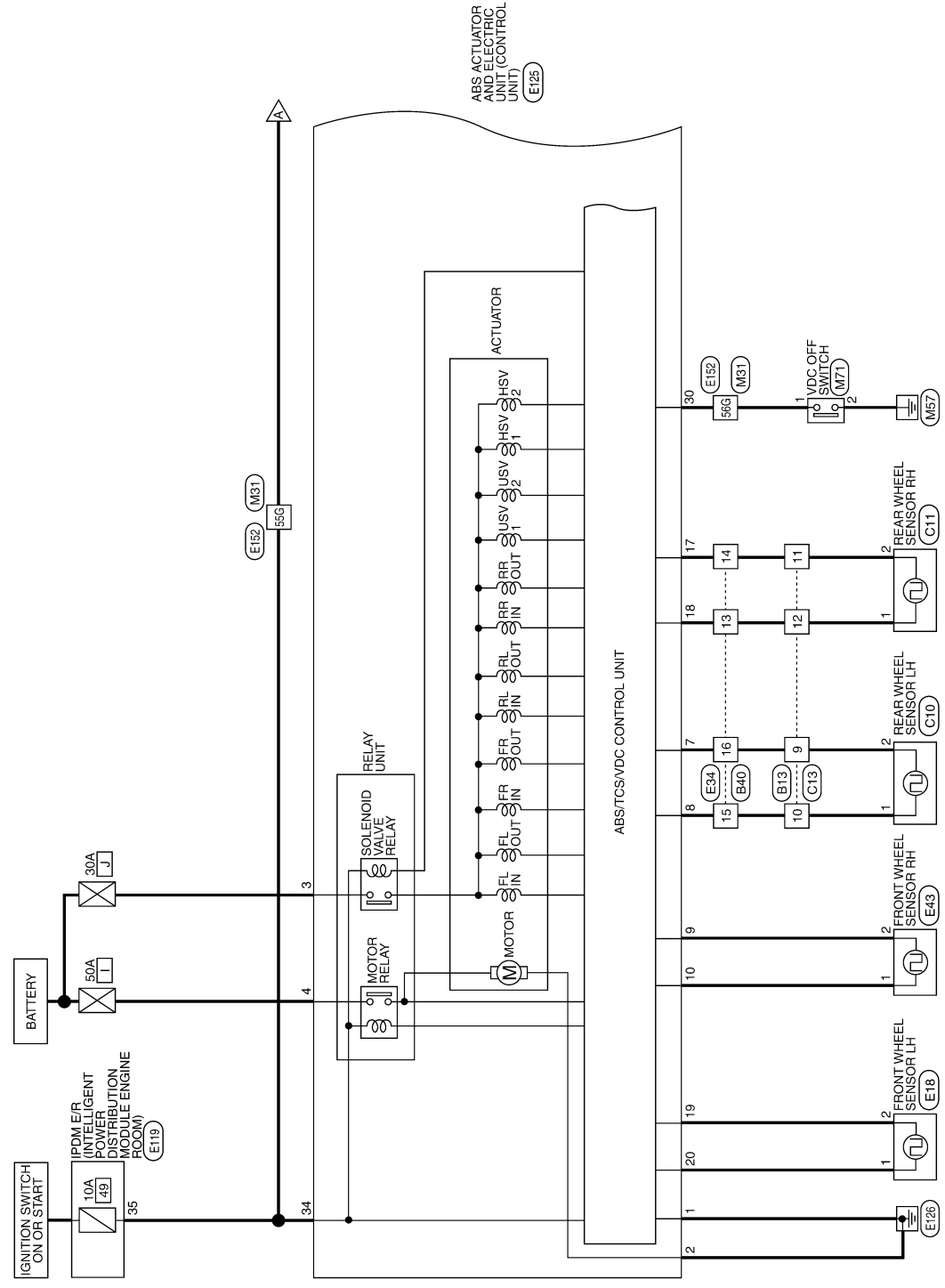

BRAKE CONTROL SYSTEM

< WIRING DIAGRAM >

[VDC/TCS/ABS]

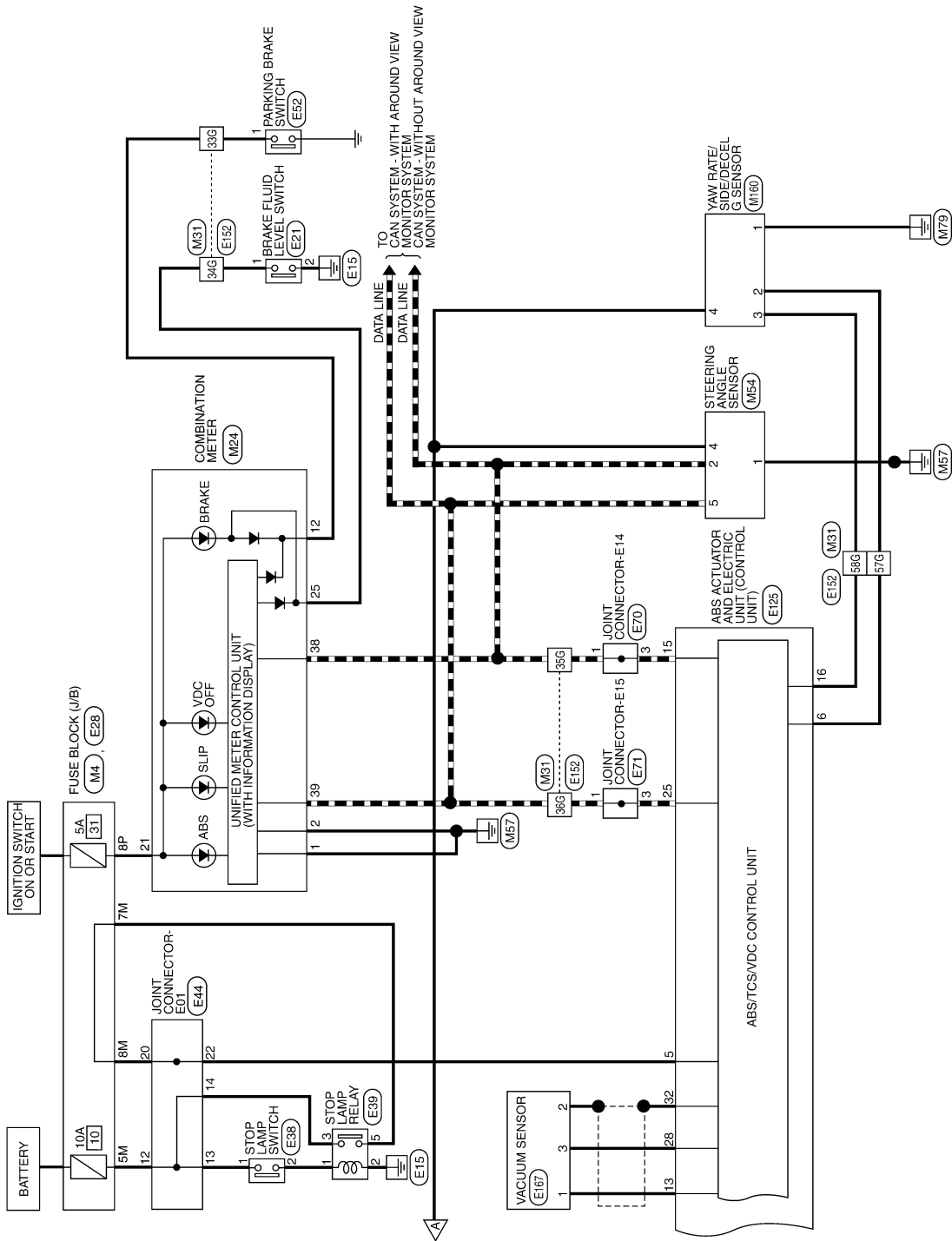

ABFWA0360GB

A
B
C
D
E
BRC
G
H
I
J
K
L
M
N
O
P

BRAKE CONTROL SYSTEM CONNECTORS

Connector No.	M4
Connector Name	FUSE BLOCK (J/B)
Connector Color	WHITE



Terminal No.	Color of Wire	Signal Name
8P	BG	-

Connector No.	M24
Connector Name	COMBINATION METER
Connector Color	WHITE

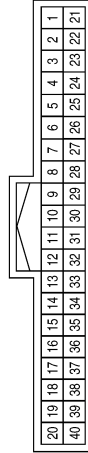

Terminal No.	Color of Wire	Signal Name
1	B	GND1
2	B	GND2
12	G	PKB
21	BG	IGN
25	G	BRAKE OIL SW
38	P	CAN-L
39	L	CAN-H

Connector No.	M31
Connector Name	WIRE TO WIRE
Connector Color	WHITE

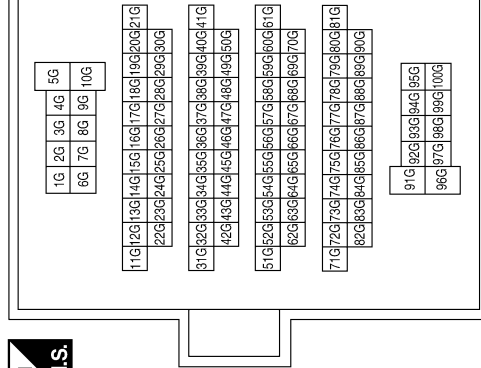

Terminal No.	Color of Wire	Signal Name
33G	G	-
34G	G	-
35G	P	-
36G	L	-
55G	G	-
56G	P	-
57G	P	-
58G	L	-

Connector No.	M54
Connector Name	STEERING ANGLE SENSOR
Connector Color	WHITE

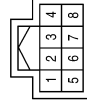

Terminal No.	Color of Wire	Signal Name
1	GR	-
2	P	-
3	-	-
4	G	-
5	L	-
6	-	-
7	-	-
8	-	-

ABFIA0723GB

BRAKE CONTROL SYSTEM

< WIRING DIAGRAM >

[VDC/TCS/ABS]

Connector No.	E18
Connector Name	FRONT WHEEL SENSOR LH
Connector Color	BLACK



Terminal No.	Color of Wire	Signal Name
1	G	-
2	W	-

Connector No.	M160
Connector Name	YAW RATE/SIDE/DECEL G SENSOR
Connector Color	BLACK

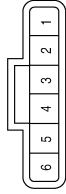

Terminal No.	Color of Wire	Signal Name
1	GR	-
2	P	-
3	L	-
4	G	-
5	-	-
6	-	-

Connector No.	M71
Connector Name	VDC OFF SWITCH
Connector Color	BLACK

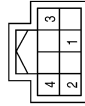

Terminal No.	Color of Wire	Signal Name
1	P	-
2	GR	-

Connector No.	E34
Connector Name	WIRE TO WIRE
Connector Color	WHITE

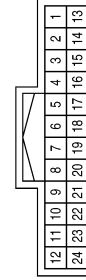

Terminal No.	Color of Wire	Signal Name
13	BG	-
14	P	-
15	R	-
16	G	-

Connector No.	E28
Connector Name	FUSE BLOCK (J/B)
Connector Color	WHITE



Terminal No.	Color of Wire	Signal Name
5M	Y	-
7M	R	-
8M	R	-

Connector No.	E21
Connector Name	BRAKE FLUID LEVEL SWITCH
Connector Color	GRAY



Terminal No.	Color of Wire	Signal Name
1	W	-
2	B	-

ABFIA0724GB

A
B
C
D
E
BRC
G
H
I
J
K
L
M
N
O
P

BRAKE CONTROL SYSTEM

< WIRING DIAGRAM >

[VDC/TCS/ABS]

Connector No.	E43
Connector Name	FRONT WHEEL SENSOR RH
Connector Color	BLACK



Terminal No.	Color of Wire	Signal Name
1	G	-
2	W	-

Connector No.	E39
Connector Name	STOP LAMP RELAY
Connector Color	BLUE



Terminal No.	Color of Wire	Signal Name
1	W	-
2	B	-
3	Y	-
5	R	-

Connector No.	E38
Connector Name	STOP LAMP SWITCH
Connector Color	WHITE



Terminal No.	Color of Wire	Signal Name
1	Y	-
2	W	-

Connector No.	E70
Connector Name	JOINT CONNECTOR-E14
Connector Color	BLACK

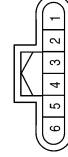

Terminal No.	Color of Wire	Signal Name
1	P	-
3	P	-

Connector No.	E52
Connector Name	PARKING BRAKE SWITCH
Connector Color	BLACK



Terminal No.	Color of Wire	Signal Name
1	LG	-

Connector No.	E44
Connector Name	JOINT CONNECTOR-E01
Connector Color	WHITE

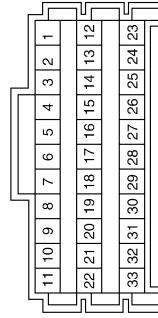

Terminal No.	Color of Wire	Signal Name
12	Y	-
13	Y	-
14	Y	-
20	R	-
22	R	-

ABFIA0725GB

BRAKE CONTROL SYSTEM

< WIRING DIAGRAM >

[VDC/TCS/ABS]

Terminal No.	Color of Wire	Signal Name
35	BR	ABS ECU

Connector No.	E119
Connector Name	IPDM E/R (INTELLIGENT POWER DISTRIBUTION MODULE ENGINE ROOM)
Connector Color	WHITE

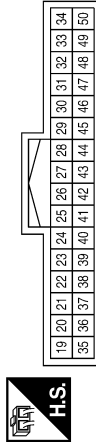

Connector No.	E71
Connector Name	JOINT CONNECTOR-E15
Connector Color	BLACK



Terminal No.	Color of Wire	Signal Name
1	L	-
3	L	-

Connector No.	E125
Connector Name	ABS ACTUATOR AND ELECTRIC UNIT (CONTROL UNIT)
Connector Color	BLACK

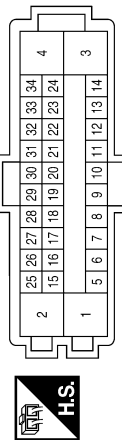

Terminal No.	Color of Wire	Signal Name
1	B	ECU (GND)
2	B/W	MOTOR (GND)
3	R	SOLENOID (POWER)
4	W	MOTOR (POWER)
5	R	STOP LAMP SW
6	P	CANM2 (-)
7	G	RR LH SEN (SIGNAL)
8	R	RR LH SEN (POWER)
9	W	FR RH SEN (SIGNAL)
10	G	FR RH SEN (POWER)
11	-	-
12	-	-
13	W	VAC SEN (SIGNAL)

Terminal No.	Color of Wire	Signal Name
14	-	-
15	P	CAN-L
16	BG	CANM2 (+)
17	P	RR RH SEN (SIGNAL)
18	BG	RR RH SEN (POWER)
19	W	FR LH SEN (SIGNAL)
20	G	FR LH SEN (POWER)
21	-	-
22	-	-
23	-	-
24	-	-
25	L	CAN-H
26	-	-
27	-	-
28	B	VAC SEN (POWER)
29	-	-
30	R	VDC OFF SW
31	-	-
32	SHIELD	VAC SEN (GND)
33	-	-
34	BR	IGN (POWER)

ABFIA0726GB

A
B
C
D
E
BRC
G
H
I
J
K
L
M
N
O
P

BRAKE CONTROL SYSTEM

< WIRING DIAGRAM >

[VDC/TCS/ABS]

Connector No.	E167
Connector Name	VACUUM SENSOR
Connector Color	BLACK



Terminal No.	Color of Wire	Signal Name
1	W	-
2	SHIELD	-
3	B	-

Terminal No.	Color of Wire	Signal Name
33G	LG	-
34G	W	-
35G	P	-
36G	L	-
55G	BR	-
56G	R	-
57G	P	-
58G	BG	-

Connector No.	E152
Connector Name	WIRE TO WIRE
Connector Color	WHITE

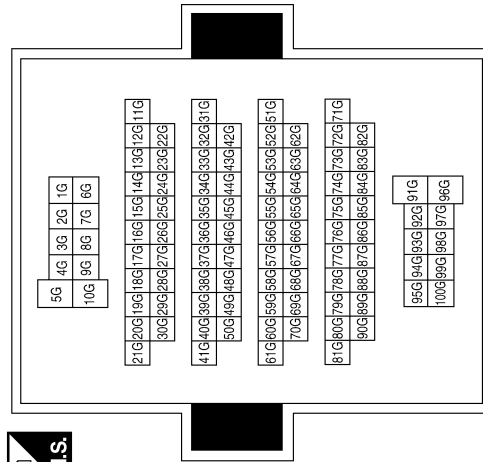

Connector No.	C13
Connector Name	WIRE TO WIRE
Connector Color	BLACK

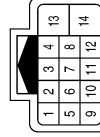

Terminal No.	Color of Wire	Signal Name
9	W	-
10	B	-
11	P	-
12	V	-

Connector No.	C11
Connector Name	REAR WHEEL SENSOR RH
Connector Color	GRAY



Terminal No.	Color of Wire	Signal Name
1	V	-
2	P	-

Connector No.	C10
Connector Name	REAR WHEEL SENSOR LH
Connector Color	BLACK



Terminal No.	Color of Wire	Signal Name
1	B	-
2	W	-

ABFIA0727GB

BRAKE CONTROL SYSTEM

< WIRING DIAGRAM >

[VDC/TCS/ABS]

A
B
C
D
E
BRC
G
H
I
J
K
L
M
N
O
P

Connector No.	B40
Connector Name	WIRE TO WIRE
Connector Color	WHITE

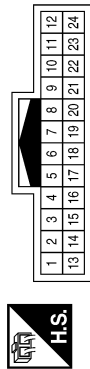

Terminal No.	Color of Wire	Signal Name
13	L	-
14	P	-
15	BR	-
16	Y	-

Connector No.	B13
Connector Name	WIRE TO WIRE
Connector Color	BLACK

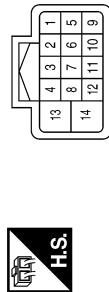

Terminal No.	Color of Wire	Signal Name
9	Y	-
10	BR	-
11	P	-
12	L	-

AAFIA0142GB

BASIC INSPECTION

DIAGNOSIS AND REPAIR WORKFLOW

Work Flow

INFOID:000000009177263

OVERALL SEQUENCE

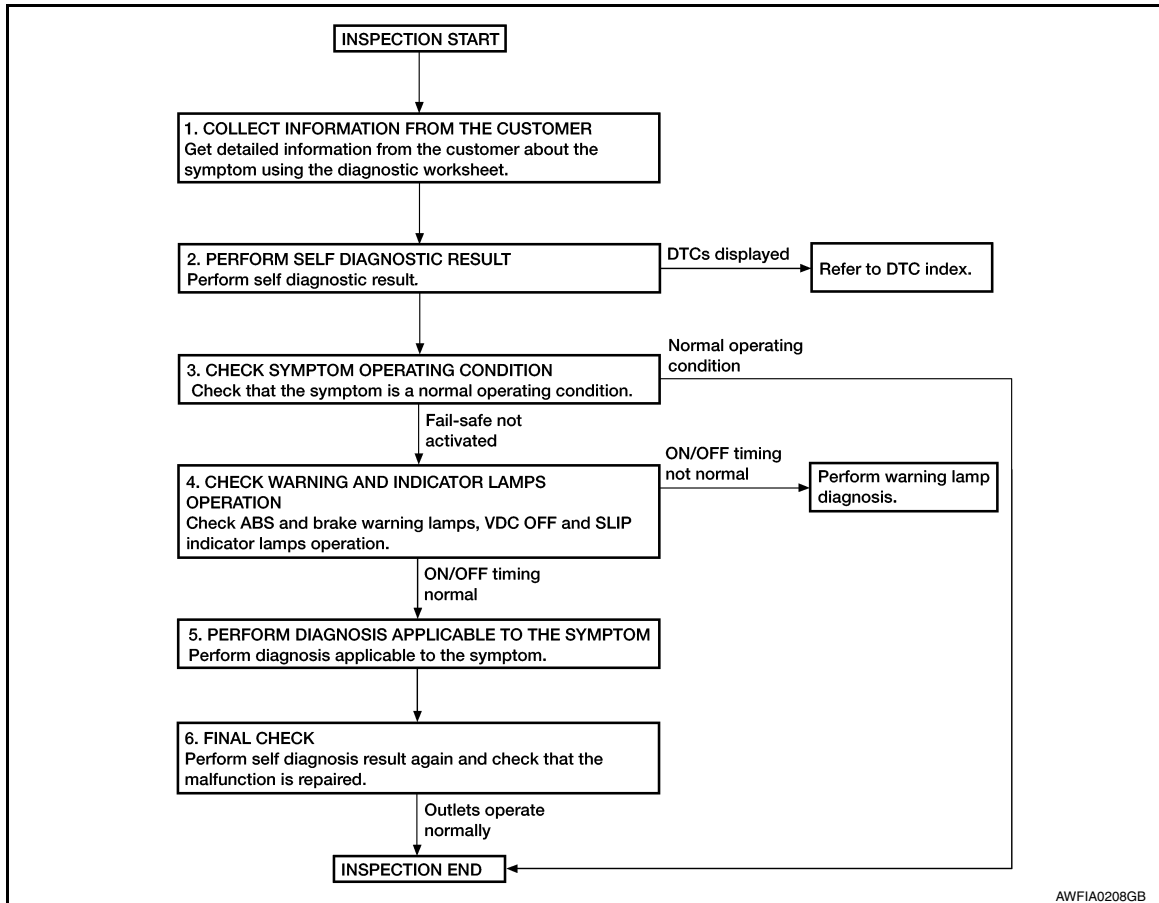

DETAILED FLOW

1. COLLECT INFORMATION FROM THE CUSTOMER

Get detailed information from the customer about the symptom (the condition and the environment when the incident/malfunction occurred) using the diagnostic worksheet. Refer to [BRC-53, "Diagnostic Work Sheet"](#).

>> GO TO 2.

2. PERFORM SELF-DIAGNOSTIC RESULT

Perform self-diagnostic result. Refer to [BRC-32, "CONSULT Function"](#).

Are any DTCs displayed?

YES >> Refer to [BRC-42, "DTC Index"](#).

NO >> GO TO 3.

3. CHECK SYMPTOM OPERATING CONDITION

Check that the symptom is a normal operating condition. Refer to [BRC-117, "Description"](#).

Is the symptom a normal operating condition?

YES >> Inspection End.

NO >> GO TO 4.

4. CHECK WARNING AND INDICATOR LAMPS OPERATION

DIAGNOSIS AND REPAIR WORKFLOW

[VDC/TCS/ABS]

< BASIC INSPECTION >

Check ABS and brake warning lamps, VDC OFF and SLIP indicator lamps operation. Refer to [BRC-11. "System Description"](#).

Is ON/OFF timing normal?

YES >> GO TO 5.

NO >> Perform warning lamp diagnosis. Refer to [BRC-106. "Component Function Check"](#) (ABS warning lamp), [BRC-107. "Component Function Check"](#) (brake warning lamp), [BRC-108. "Component Function Check"](#) (VDC OFF indicator lamp) or [BRC-109. "Component Function Check"](#) (SLIP indicator lamp).

5. PERFORM DIAGNOSIS APPLICABLE TO THE SYMPTOM

Perform diagnosis applicable to the symptom. Refer to [BRC-110. "Symptom Table"](#).

>> GO TO 6.

6. FINAL CHECK

Perform self-diagnostic result again, and check that the malfunction is repaired. After checking, erase the self-diagnosis memory. Refer to [BRC-32. "CONSULT Function"](#).

>> Inspection End.

Diagnostic Work Sheet

INFOID:000000009177264

Customer name MR/MS	Model & Year	VIN	
Engine #	Trans.	Mileage	
Incident Date	Manuf. Date	In Service Date	
Symptoms	<input type="checkbox"/> Noise and vibration (from engine compartment) <input type="checkbox"/> Noise and vibration (from axle)	<input type="checkbox"/> Warning / Indicator activate	<input type="checkbox"/> Firm pedal operation <input type="checkbox"/> Large stroke pedal operation
	<input type="checkbox"/> TCS does not work (Rear wheels slip when accelerating)	<input type="checkbox"/> ABS does not work (Wheels lock when braking)	<input type="checkbox"/> Lack of sense of acceleration
Engine conditions	<input type="checkbox"/> When starting <input type="checkbox"/> After starting		
Road conditions	<input type="checkbox"/> Low friction road (<input type="checkbox"/> Snow <input type="checkbox"/> Gravel <input type="checkbox"/> Other) <input type="checkbox"/> Bumps / potholes		
Driving conditions	<input type="checkbox"/> Full-acceleration <input type="checkbox"/> High speed cornering <input type="checkbox"/> Vehicle speed: Greater than 10 km/h (6 MPH) <input type="checkbox"/> Vehicle speed: 10 km/h (6 MPH) or less <input type="checkbox"/> Vehicle is stopped		
Applying brake conditions	<input type="checkbox"/> Suddenly <input type="checkbox"/> Gradually		
Other conditions	<input type="checkbox"/> Operation of electrical equipment <input type="checkbox"/> Shift change <input type="checkbox"/> Other descriptions		

SFIA3265E

ADDITIONAL SERVICE WHEN REPLACING ABS ACTUATOR AND ELECTRIC UNIT (CONTROL UNIT)

< BASIC INSPECTION >

[VDC/TCS/ABS]

ADDITIONAL SERVICE WHEN REPLACING ABS ACTUATOR AND ELECTRIC UNIT (CONTROL UNIT)

Description

INFOID:000000009177265

After replacing the ABS actuator and electric unit (control unit), perform the following procedures:

- Neutral position adjustment for the steering angle sensor
- Calibration of the decel G sensor

Work Procedure

INFOID:000000009177266

1.PERFORM THE NEUTRAL POSITION ADJUSTMENT FOR THE STEERING ANGLE SENSOR

Perform the neutral position adjustment for the steering angle sensor.

>> Refer to [BRC-55. "Work Procedure"](#), GO TO 2.

2.PERFORM CALIBRATION OF THE DECEL G SENSOR

Perform calibration of the decel G sensor.

>> Refer to [BRC-57. "Work Procedure"](#).

ADJUSTMENT OF STEERING ANGLE SENSOR NEUTRAL POSITION

< BASIC INSPECTION >

[VDC/TCS/ABS]

ADJUSTMENT OF STEERING ANGLE SENSOR NEUTRAL POSITION

Description

INFOID:000000009177267

Refer to the table below to determine if adjustment of steering angle sensor neutral position is required.

×: Required –: Not required

Situation	Adjustment of steering angle sensor neutral position
Removing/Installing ABS actuator and electric unit (control unit)	—
Replacing ABS actuator and electric unit (control unit)	×
Removing/Installing steering angle sensor	×
Replacing steering angle sensor	×
Removing/Installing steering components	×
Replacing steering components	×
Removing/Installing suspension components	×
Replacing suspension components	×
Change tires to new ones	—
Tire rotation	—
Adjusting wheel alignment	×
Battery disconnection	×

Work Procedure

INFOID:000000009177268

ADJUSTMENT OF STEERING ANGLE SENSOR NEUTRAL POSITION

CAUTION:

**To adjust neutral position of steering angle sensor, make sure to use CONSULT.
(Adjustment cannot be done without CONSULT).**

1. ALIGN THE VEHICLE STATUS

Stop vehicle with front wheels in straight-ahead position.

>> GO TO 2.

2. PERFORM THE NEUTRAL POSITION ADJUSTMENT FOR THE STEERING ANGLE SENSOR

1. On the CONSULT screen, touch "WORK SUPPORT" and "ST ANG SEN ADJUSTMENT" in order.
2. Touch "START".

CAUTION:

Do not touch steering wheel while adjusting steering angle sensor.

3. After approximately 10 seconds, touch "END".

NOTE:

After approximately 60 seconds, it ends automatically.

4. Turn ignition switch OFF, then turn it ON again.

CAUTION:

Be sure to perform above operation.

>> GO TO 3.

3. CHECK DATA MONITOR

1. Run vehicle with front wheels in straight-ahead position, then stop.
2. Select "DATA MONITOR". Then make sure "STR ANGLE SIG" is within $0 \pm 2.5^\circ$.

Is the steering angle within the specified range?

YES >> GO TO 4.

NO >> Perform the neutral position adjustment for the steering angle sensor again, GO TO 1.

4. ERASE THE SELF-DIAGNOSIS MEMORY

Erase the self-diagnosis memory of the ABS actuator and electric unit (control unit) and ECM.

ADJUSTMENT OF STEERING ANGLE SENSOR NEUTRAL POSITION

[VDC/TCS/ABS]

< BASIC INSPECTION >

- ABS actuator and electric unit (control unit): Refer to [BRC-32, "CONSULT Function"](#).
- ECM: Refer to [EC-61, "CONSULT Function"](#).

Are the memories erased?

YES >> Inspection End.

NO >> Check the items indicated by the self-diagnosis.

CALIBRATION OF DECEL G SENSOR

< BASIC INSPECTION >

[VDC/TCS/ABS]

CALIBRATION OF DECEL G SENSOR

Description

INFOID:000000009177269

Refer to the table below to determine if calibration of the decel G sensor is required.

×: Required –: Not required

Situation	Calibration of decel G sensor
Removing/Installing ABS actuator and electric unit (control unit)	—
Replacing ABS actuator and electric unit (control unit)	×
Removing/Installing steering components	—
Replacing steering components	—
Removing/Installing suspension components	—
Replacing suspension components	—
Removing/Installing tire	—
Replacing tire	—
Tire rotation	—
Adjusting wheel alignment	—
Removing/Installing yaw rate/side/decel G sensor	×
Replacing yaw rate/side/decel G sensor	×

Work Procedure

INFOID:000000009177270

CALIBRATION OF DECEL G SENSOR

CAUTION:

To calibrate the decel G sensor, make sure to use CONSULT.
(Calibration cannot be done without CONSULT).

1. ALIGN THE VEHICLE STATUS

Stop vehicle with front wheels in straight-ahead position.

>> GO TO 2.

2. PERFORM CALIBRATION OF DECEL G SENSOR

1. On the CONSULT screen, touch "WORK SUPPORT" and "DECEL G SEN CALIBRATION" in order.
2. Touch "START".
3. After approximately 10 seconds, touch "END".

NOTE:

After approximately 60 seconds, it ends automatically.

4. Turn ignition switch OFF, then turn it ON again.

CAUTION:

Be sure to perform above operation.

>> GO TO 3.

3. CHECK DATA MONITOR

1. Run vehicle with front wheels in straight-ahead position, then stop.
2. Select "DATA MONITOR". Then make sure "DECEL G SEN" is within $\pm 0.08G$.

Is the inspection result normal?

YES >> GO TO 4.

NO >> Perform calibration of decel G sensor again, GO TO 1.

4. ERASE THE SELF-DIAGNOSIS MEMORY

Erase the self-diagnosis memory of the ABS actuator and electric unit (control unit) and ECM.

- ABS actuator and electric unit (control unit): Refer to [BRC-32, "CONSULT Function"](#).
- ECM: Refer to [EC-61, "CONSULT Function"](#).

CALIBRATION OF DECEL G SENSOR

[VDC/TCS/ABS]

< BASIC INSPECTION >

Are the memories erased?

YES >> Inspection End.

NO >> Check the items indicated by the self-diagnosis.

C1101, C1102, C1103, C1104 WHEEL SENSOR

< DTC/CIRCUIT DIAGNOSIS >

[VDC/TCS/ABS]

DTC/CIRCUIT DIAGNOSIS

C1101, C1102, C1103, C1104 WHEEL SENSOR

DTC Logic

INFOID:000000009729236

DTC DETECTION LOGIC

DTC	Display Item	Malfunction detected condition	Possible causes
C1101	RR RH SENSOR-1	<ul style="list-style-type: none">When power supply voltage of rear wheel sensor RH is low.When an open or shorted circuit is detected in rear wheel sensor RH circuit.	<ul style="list-style-type: none">Harness or connectorWheel sensorABS actuator and electric unit (control unit)
C1102	RR LH SENSOR-1	<ul style="list-style-type: none">When power supply voltage of rear wheel sensor LH is low.When an open or shorted circuit is detected in rear wheel sensor LH circuit.	
C1103	FR RH SENSOR-1	<ul style="list-style-type: none">When power supply voltage of front wheel sensor RH is low.When an open or shorted circuit is detected in front wheel sensor RH circuit.	
C1104	FR LH SENSOR-1	<ul style="list-style-type: none">When power supply voltage of front wheel sensor LH is low.When an open or shorted circuit is detected in front wheel sensor LH circuit.	

DTC CONFIRMATION PROCEDURE

1. CHECK SELF-DIAGNOSTIC RESULT

ⓐ With CONSULT.

- Start engine and drive vehicle at approximately 21 km/h (13 MPH) or more for approximately 5 minutes.
- Perform self-diagnostic result.

Is DTC C1101, C1102, C1103 or C1104 detected?

- YES >> Proceed to diagnosis procedure. Refer to [BRC-59, "Diagnosis Procedure"](#).
NO >> Inspection End.

Diagnosis Procedure

INFOID:000000009729237

Regarding Wiring Diagram information, refer to [BRC-44, "Wiring Diagram"](#).

1. CONFIRM DTC

ⓐ With CONSULT

- Perform self-diagnostic result of ABS and record all active DTCs.
- Clear all DTCs.
- Perform DTC confirmation procedure. Refer to [BRC-59, "DTC Logic"](#).

Does DTC C1101, C1102, C1103 or C1104 reset?

- YES >> GO TO 2.
NO >> Refer to GI-XX, "Intermittent Incident".

2. INSPECT WHEEL SENSOR

Inspect the suspect wheel sensor for damage or deformation.

Is the inspection result normal?

- YES >> GO TO 3.
NO >> Repair or replace as necessary.

3. HARNESS AND CONNECTOR INSPECTION

C1101, C1102, C1103, C1104 WHEEL SENSOR

< DTC/CIRCUIT DIAGNOSIS >

[VDC/TCS/ABS]

1. Disconnect ABS actuator and electric unit (control unit) connector E125 and wheel sensor connector of suspect wheel.
2. Check harness, connectors and terminals for corrosion, deformation, disconnection, looseness or damage.

Is the inspection result normal?

- YES >> GO TO 4.
 NO >> Repair or replace as necessary.

4. CHECK WHEEL SENSOR OUTPUT SIGNAL

1. Connect ABS active wheel sensor tester (J-45741) to wheel sensor using appropriate adapter.
2. Turn on the ABS active wheel sensor tester power switch.

NOTE:

The green POWER indicator should illuminate. If the POWER indicator does not illuminate, replace the battery in the ABS active wheel sensor tester before proceeding.

3. Spin the wheel of the vehicle by hand and observe the red SENSOR indicator on the ABS active wheel sensor tester. The red SENSOR indicator should flash ON and OFF to indicate an output signal.

NOTE:

If the red SENSOR indicator illuminates but does not flash, reverse the polarity of the tester leads and retest.

Does the ABS active wheel sensor tester detect a signal?

- YES >> GO TO 5.
 NO >> Replace the wheel sensor. Refer to [BRC-118, "Removal and Installation - Front Wheel Sensor"](#) or [BRC-120, "Removal and Installation - Rear Wheel Sensor"](#).

5. CHECK WIRING HARNESS FOR SHORT TO VOLTAGE

1. Turn ignition switch ON.
2. Check voltage between wheel sensor harness connector terminals of suspect wheel and ground.

Wheel Sensor			Ground	Voltage
Wheel	Connector	Terminal		
Front LH	E18	1	—	0V
		2		
Front RH	E43	1		
		2		
Rear LH	C10	1		
		2		
Rear RH	C11	1		
		2		

Is the inspection result normal?

- YES >> GO TO 6.
 NO >> Repair the circuit.

6. CHECK WIRING HARNESS FOR SHORT TO GROUND

1. Turn ignition switch OFF.
2. Check continuity between wheel sensor harness connector terminals of suspect wheel and ground.

Wheel Sensor			Ground	Continuity
Wheel	Connector	Terminal		

C1101, C1102, C1103, C1104 WHEEL SENSOR

< DTC/CIRCUIT DIAGNOSIS >

[VDC/TCS/ABS]

Front LH	E18	1	—	No			
		2					A
Front RH	E43	1					B
		2					
Rear LH	C10	1					C
		2					
Rear RH	C11	1					
		2					

Is the inspection result normal?

YES >> GO TO 7.

NO >> Repair the circuit.

7. CHECK WIRING HARNESS FOR SHORT BETWEEN CIRCUITS

Check continuity between wheel sensor harness connector terminals of suspect wheel.

Wheel Sensor		(+)	(-)	Continuity
Wheel	Connector	Terminal	Terminal	
Front LH	E18	1	2	No
Front RH	E43			
Rear LH	C10			
Rear RH	C11			

Is the inspection result normal?

YES >> GO TO 8.

NO >> Repair the circuit.

8. CHECK WIRING HARNESS FOR OPEN CIRCUIT

Check continuity between ABS actuator and electric unit (control unit) harness connector E125 and harness connector of suspect wheel sensor.

Wheel sensor	ABS actuator and electric unit (control unit)		Wheel sensor		Continuity
	Connector	Terminal	Connector	Terminal	
Front LH	E125	20	E18	1	Yes
		19		2	
Front RH		10	E43	1	
		9		2	
Rear LH		8	C10	1	
		7		2	
Rear RH		18	C11	1	
		17		2	

Is the inspection result normal?

YES >> GO TO 9.

NO >> Repair the circuit.

9. CHECK ABS ACTUATOR AND ELECTRIC UNIT (CONTROL UNIT) POWER SUPPLY CIRCUIT

1. Turn ignition switch ON.
2. Check voltage between ABS actuator and electric unit (control unit) harness connector E125 terminal and ground.

C1101, C1102, C1103, C1104 WHEEL SENSOR

< DTC/CIRCUIT DIAGNOSIS >

[VDC/TCS/ABS]

ABS actuator and electric unit (control unit)		Ground	Condition	Voltage (Approx.)
Connector	Terminal			
E125	34	—	Ignition switch ON	Battery voltage
			Ignition switch OFF	0V

Is the inspection result normal?

YES >> GO TO 10.

NO >> Check the following:

- 10A fuse No. 49 located in the IPDM E/R
- Harness between ABS actuator and electric unit (control unit) and IPDM E/R

10. CHECK ABS ACTUATOR AND ELECTRIC UNIT (CONTROL UNIT) GROUND CIRCUIT

1. Turn ignition switch OFF.
2. Check continuity between ABS actuator and electric unit (control unit) connector E125 terminals and ground.

ABS actuator and electric unit (control unit)		—	Continuity
Connector	Terminal		
E125	1	Ground	Yes
	2		

Is the inspection result normal?

YES >> GO TO 11.

NO >> Repair or replace malfunctioning components.

11. CHECK WHEEL SENSOR INPUT VOLTAGE

1. Connect ABS actuator and electric unit (control unit) connector E125.
2. Turn ignition switch ON.
3. Check voltage between suspect wheel sensor harness connector terminals.

Wheel Sensor		(+)	(-)	Voltage (Approx.)
Wheel	Connector	Terminal	Terminal	
Front LH	E18	1	2	Battery voltage
Front RH	E43			
Rear LH	C10			
Rear RH	C11			

Is the inspection result normal?

YES >> Replace wheel sensor. Refer to [BRC-118, "Removal and Installation - Front Wheel Sensor"](#) or [BRC-120, "Removal and Installation - Rear Wheel Sensor"](#). Then, GO TO 12.

NO >> Replace ABS actuator and electric unit (control unit). Refer to [BRC-123, "Removal and Installation"](#).

12. CONFIRM REPAIR

Ⓟ With CONSULT

1. Clear all DTCs.
2. Perform DTC confirmation procedure. Refer to [BRC-59, "DTC Logic"](#).

Does DTC C1105, C1106, C1107 or C1108 reset?

YES >> Replace ABS actuator and electric unit (control unit). Refer to [BRC-123, "Removal and Installation"](#).

NO >> Inspection End.

C1105, C1106, C1107, C1108 WHEEL SENSOR

< DTC/CIRCUIT DIAGNOSIS >

[VDC/TCS/ABS]

C1105, C1106, C1107, C1108 WHEEL SENSOR

DTC Logic

INFOID:000000009729238

DTC DETECTION LOGIC

DTC	Display Item	Malfunction detected condition	Possible causes
C1105	RR RH SENSOR-2	<ul style="list-style-type: none">When distance between rear wheel sensor RH and rear wheel sensor RH rotor is large.When installation of rear wheel sensor RH or rear wheel sensor RH rotor is not normal.	<ul style="list-style-type: none">Wheel sensorABS actuator and electric unit (control unit)Sensor rotor
C1106	RR LH SENSOR-2	<ul style="list-style-type: none">When distance between rear wheel sensor LH and rear wheel sensor LH rotor is large.When installation of rear wheel sensor LH or rear wheel sensor LH rotor is not normal.	
C1107	FR RH SENSOR-2	<ul style="list-style-type: none">When distance between front wheel sensor RH and front wheel sensor RH rotor is large.When installation of front wheel sensor RH or front wheel sensor RH rotor is not normal.	
C1108	FR LH SENSOR-2	<ul style="list-style-type: none">When distance between front wheel sensor LH and front wheel sensor LH rotor is large.When installation of front wheel sensor LH or front wheel sensor LH rotor is not normal.	

DTC CONFIRMATION PROCEDURE

1. CHECK SELF-DIAGNOSTIC RESULT

Ⓜ With CONSULT.

- Start engine and drive vehicle at approximately 21 km/h (13 MPH) or more for approximately 5 minutes.
- Perform self-diagnostic result.

Is DTC C1105, C1106, C1107 or C1108 detected?

YES >> Proceed to diagnosis procedure. Refer to [BRC-63, "Diagnosis Procedure"](#).

NO >> Inspection End.

Diagnosis Procedure

INFOID:000000009729239

Regarding Wiring Diagram information, refer to [BRC-44, "Wiring Diagram"](#).

1. CONFIRM DTC

Ⓜ With CONSULT

- Perform self-diagnostic result of ABS and record all active DTCs.
- Clear all DTCs.
- Perform DTC confirmation procedure. Refer to [BRC-59, "DTC Logic"](#).

Does DTC C1105, C1106, C1107 or C1108 reset?

YES >> GO TO 2.

NO >> Refer to GI-XX, "Intermittent Incident".

2. CHECK TIRE PRESSURE AND TIRE WEAR

Check tires for excessive wear and proper inflation. Refer to [WT-57, "Inspection"](#).

Is the inspection result normal?

YES >> GO TO 3.

NO >> Repair or replace as necessary.

3. CHECK WHEEL SENSOR

Check wheel sensor for the following:

- Proper installation

C1105, C1106, C1107, C1108 WHEEL SENSOR

[VDC/TCS/ABS]

< DTC/CIRCUIT DIAGNOSIS >

- Physical damage
- Contamination

Is the inspection result normal?

YES >> GO TO 4.

NO >> Repair or replace as necessary.

4.CHECK SENSOR ROTOR

Check sensor rotor for the following:

- Contamination
- Physical damage (missing teeth, cracks, etc.)
- Foreign material
- Looseness

Is the inspection result normal?

YES >> Replace the wheel sensor. Refer to [BRC-118. "Removal and Installation - Front Wheel Sensor"](#) or [BRC-120. "Removal and Installation - Rear Wheel Sensor"](#). Then, GO TO 5.

NO >> Repair or replace as necessary.

5.CONFIRM REPAIR

Ⓟ With CONSULT

1. Clear all DTCs.
2. Perform DTC confirmation procedure. Refer to [BRC-59. "DTC Logic"](#).

Does DTC C1105, C1106, C1107 or C1108 reset?

YES >> Replace ABS actuator and electric unit (control unit). Refer to [BRC-123. "Removal and Installation"](#).

NO >> Inspection End.

C1109 POWER AND GROUND SYSTEM

< DTC/CIRCUIT DIAGNOSIS >

[VDC/TCS/ABS]

C1109 POWER AND GROUND SYSTEM

DTC Logic

INFOID:000000009177275

DTC DETECTION LOGIC

DTC	Display Item	Malfunction detected condition	Possible causes
C1109	BATTERY VOLTAGE [ABNORMAL]	<ul style="list-style-type: none"> When ignition voltage is 10 V or less. When ignition voltage is 16 V or more. 	<ul style="list-style-type: none"> Harness or connector ABS actuator and electric unit (control unit) Fuse Ignition power supply system Battery

DTC CONFIRMATION PROCEDURE

1. CHECK SELF-DIAGNOSTIC RESULT

Ⓜ With CONSULT.

- Turn the ignition switch OFF to ON.
- Perform self-diagnostic result.

Is DTC C1109 detected?

- YES >> Proceed to diagnosis procedure. Refer to [BRC-65, "Diagnosis Procedure"](#).
 NO >> Inspection End.

Diagnosis Procedure

INFOID:000000009177276

Regarding Wiring Diagram information, refer to [BRC-44, "Wiring Diagram"](#).

1. CONNECTOR INSPECTION

- Turn ignition switch OFF.
- Disconnect ABS actuator and electric unit (control unit) connectors.
- Check connectors and terminals for deformation, disconnection, looseness or damage.

Is the inspection result normal?

- YES >> GO TO 2.
 NO >> Repair or replace as necessary.

2. CHECK ABS ACTUATOR AND ELECTRIC UNIT (CONTROL UNIT) IGNITION POWER SUPPLY CIRCUIT

Check voltage between ABS actuator and electric unit (control unit) connector E125 terminal 34 and ground.

ABS actuator and electric unit (control unit)		Ground	Condition	Voltage (Approx.)
Connector	Terminal			
E125	34	—	Ignition switch ON	Battery voltage
			Ignition switch OFF	0V

Is the inspection result normal?

- YES >> GO TO 3.
 NO >> Repair or replace malfunctioning components.

3. CHECK ABS ACTUATOR AND ELECTRIC UNIT (CONTROL UNIT) BATTERY POWER SUPPLY CIRCUIT

Check voltage between ABS actuator and electric unit (control unit) connector E125 terminals 3, 4 and ground.

ABS actuator and electric unit (control unit)		Ground	Voltage (Approx.)
Connector	Terminal		

A
B
C
D
E
G
H
I
J
K
L
M
N
O
P

BRC

C1109 POWER AND GROUND SYSTEM

< DTC/CIRCUIT DIAGNOSIS >

[VDC/TCS/ABS]

E125	3	—	Battery voltage
	4		

Is the inspection result normal?

YES >> GO TO 4.

NO >> Repair or replace malfunctioning components.

4. CHECK ABS ACTUATOR AND ELECTRIC UNIT (CONTROL UNIT) GROUND CIRCUIT

1. Turn ignition switch OFF.
2. Check continuity between ABS actuator and electric unit (control unit) connector E125 terminals 1, 2 and ground.

ABS actuator and electric unit (control unit)		—	Continuity
Connector	Terminal		
E125	1	Ground	Yes
	2		

Is the inspection result normal?

YES >> Replace ABS actuator and electric unit (control unit). Refer to [BRC-123, "Removal and Installation"](#).

NO >> Repair or replace malfunctioning components.

C1111 PUMP MOTOR

< DTC/CIRCUIT DIAGNOSIS >

[VDC/TCS/ABS]

C1111 PUMP MOTOR

DTC Logic

INFOID:000000009177277

DTC DETECTION LOGIC

DTC	Display Item	Malfunction detected condition	Possible causes
C1111	PUMP MOTOR	When a malfunction is detected in motor or motor relay.	<ul style="list-style-type: none">• Harness or connector• ABS actuator and electric unit (control unit)• Fusible link• Battery power supply system

DTC CONFIRMATION PROCEDURE

1. CHECK SELF-DIAGNOSTIC RESULT

Ⓜ With CONSULT.

1. Turn ignition switch OFF.
2. Depress brake pedal 20 times or more.
3. Start the engine and wait for 3 minutes or more.
4. Perform self-diagnostic result.

Is DTC C1111 detected?

- YES >> Proceed to diagnosis procedure. Refer to [BRC-67, "Diagnosis Procedure"](#).
NO >> Inspection End.

Diagnosis Procedure

INFOID:000000009177278

Regarding Wiring Diagram information, refer to [BRC-44, "Wiring Diagram"](#).

1. CONNECTOR INSPECTION

1. Turn ignition switch OFF.
2. Disconnect ABS actuator and electric unit (control unit) connectors.
3. Check connectors and terminals for deformation, disconnection, looseness or damage.

Is the inspection result normal?

- YES >> GO TO 2.
NO >> Repair or replace as necessary.

2. CHECK ABS MOTOR AND MOTOR RELAY BATTERY POWER SUPPLY

Check voltage between ABS actuator and electric unit (control unit) connector E125 terminal 4 and ground.

ABS actuator and electric unit (control unit)		—	Voltage (Approx.)
Connector	Terminal		
E125	4	Ground	Battery voltage

Is the inspection result normal?

- YES >> GO TO 3.
NO >> Repair or replace malfunctioning components.

3. CHECK ABS ACTUATOR AND ELECTRIC UNIT (CONTROL UNIT) GROUND CIRCUIT

Check continuity between ABS actuator and electric unit (control unit) connector E125 terminals 1, 2 and ground.

C1111 PUMP MOTOR

< DTC/CIRCUIT DIAGNOSIS >

[VDC/TCS/ABS]

ABS actuator and electric unit (control unit)		—	Continuity
Connector	Terminal		
E125	1	Ground	Yes
	2		

Is the inspection result normal?

YES >> Replace ABS actuator and electric unit (control unit). Refer to [BRC-123, "Removal and Installation"](#)

NO >> Repair or replace harness.

C1115 ABS SENSOR [ABNORMAL SIGNAL]

< DTC/CIRCUIT DIAGNOSIS >

[VDC/TCS/ABS]

C1115 ABS SENSOR [ABNORMAL SIGNAL]

DTC Logic

INFOID:000000009177279

DTC DETECTION LOGIC

DTC	Display Item	Malfunction detected condition	Possible causes
C1115	ABS SENSOR [ABNORMAL SIGNAL]	When difference in wheel speed between any wheel and others is detected while the vehicle is driven because of installation of tires other than specified.	<ul style="list-style-type: none">• Harness or connector• Wheel sensor• Sensor rotor• ABS actuator and electric unit (control unit)

DTC CONFIRMATION PROCEDURE

1. CHECK SELF-DIAGNOSTIC RESULT

Ⓜ With CONSULT.

1. Start engine and drive vehicle at approximately 30 km/h (19 MPH) or more for approximately 1 minute.
2. Perform self-diagnostic result.

Is DTC C1115 detected?

- YES >> Proceed to diagnosis procedure. Refer to [BRC-69, "Diagnosis Procedure"](#).
NO >> Inspection End.

Diagnosis Procedure

INFOID:000000009177280

Regarding Wiring Diagram information, refer to [BRC-44, "Wiring Diagram"](#).

CAUTION:

Do not check between wheel sensor terminals.

1. CONNECTOR INSPECTION

1. Disconnect ABS actuator and electric unit (control unit) connector E125 and wheel sensor connector of wheel with DTC.
2. Check terminals for deformation, disconnection, looseness or damage.

Is the inspection result normal?

- YES >> GO TO 2.
NO >> Repair or replace as necessary.

2. CHECK WHEEL SENSOR OUTPUT SIGNAL

1. Connect ABS active wheel sensor tester (J-45741) to wheel sensor using appropriate adapter.
2. Turn on the ABS active wheel sensor tester power switch.

NOTE:

The green POWER indicator should illuminate. If the POWER indicator does not illuminate, replace the battery in the ABS active wheel sensor tester before proceeding.

3. Spin the wheel of the vehicle by hand and observe the red SENSOR indicator on the ABS active wheel sensor tester. The red SENSOR indicator should flash on and off to indicate an output signal.

NOTE:

If the red SENSOR indicator illuminates but does not flash, reverse the polarity of the tester leads and retest.

Does the ABS active wheel sensor tester detect a signal?

- YES >> GO TO 3.
NO >> Replace the wheel sensor. Refer to [BRC-118, "Removal and Installation - Front Wheel Sensor"](#) or [BRC-120, "Removal and Installation - Rear Wheel Sensor"](#).

3. CHECK TIRES

Check the inflation pressure, wear and size of each tire.

Is the inspection result normal?

C1115 ABS SENSOR [ABNORMAL SIGNAL]

[VDC/TCS/ABS]

< DTC/CIRCUIT DIAGNOSIS >

YES >> GO TO 4.

NO >> Adjust tire pressure, or replace tire(s).

4.CHECK WIRING HARNESS FOR SHORT CIRCUIT

Check continuity between wheel sensor connector terminals and ground of wheel with DTC.

Wheel Sensor			Ground	Continuity
Wheel	Connector	Terminal		
Front LH	E18	1	—	No
		2		
Front RH	E43	1		
		2		
Rear LH	C10	1		
		2		
Rear RH	C11	1		
		2		

Is the inspection result normal?

YES >> GO TO 5.

NO >> Repair the circuit.

5.CHECK WIRING HARNESS FOR OPEN CIRCUIT

Check continuity between ABS actuator and electric unit (control unit) connector E125 and wheel sensor connector of wheel with DTC.

Wheel sensor	ABS actuator and electric unit (control unit)		Wheel sensor		Continuity
	Connector	Terminal	Connector	Terminal	
Front LH	E125	20	E18	1	Yes
		19		2	
Front RH		10	E43	1	
		9		2	
Rear LH		8	C10	1	
		7		2	
Rear RH		18	C11	1	
		17		2	

Is the inspection result normal?

YES >> Replace the ABS actuator and electric unit (control unit). Refer to [BRC-123, "Removal and Installation"](#).

NO >> Repair the circuit.

C1116 STOP LAMP SWITCH

< DTC/CIRCUIT DIAGNOSIS >

[VDC/TCS/ABS]

C1116 STOP LAMP SWITCH

DTC Logic

INFOID:000000009177281

DTC DETECTION LOGIC

DTC	Display Item	Malfunction detected condition	Possible causes
C1116	STOP LAMP SW	When stop lamp switch signal is not input when brake pedal operates.	<ul style="list-style-type: none"> • Harness or connector • Stop lamp switch • ABS actuator and electric unit (control unit) • Resistor (models without ICC system) • Battery power supply system

DTC CONFIRMATION PROCEDURE

1. CHECK SELF-DIAGNOSIS RESULT

Ⓜ With CONSULT

1. Erase self-diagnosis result for "ABS".
2. Turn the ignition switch OFF, and wait 10 seconds or more.
3. Start the engine.

CAUTION:

Never start the vehicle.

4. Depress the brake pedal several times.
5. Perform self-diagnosis for "ABS".

Is DTC "C1116" detected?

- YES >> Refer to [BRC-71, "Diagnosis Procedure"](#).
 NO >> Inspection End.

Diagnosis Procedure

INFOID:000000009177282

Regarding Wiring Diagram information, refer to [BRC-44, "Wiring Diagram"](#).

1. CONNECTOR INSPECTION

1. Disconnect stop lamp relay connector and ABS actuator and electric unit (control unit) connector.
2. Check terminals for deformation, disconnection, looseness or damage.

Is the inspection result normal?

- YES >> GO TO 2.
 NO >> Repair or replace as necessary.

2. CHECK STOP LAMP SWITCH CIRCUIT

1. Connect stop lamp relay connector.
2. Check voltage between ABS actuator and electric unit (control unit) connector E125 terminal 5 and ground.

ABS actuator and electric unit (control unit)		Ground	Condition	Voltage (Approx.)
Connector	Terminal			
E125	5	—	Brake pedal depressed	Battery voltage
			Brake pedal released	0V

Is the inspection result normal?

- YES >> Replace ABS actuator and electric unit (control unit). Refer to [BRC-123, "Removal and Installation"](#).
 NO >> GO TO 3.

C1116 STOP LAMP SWITCH

< DTC/CIRCUIT DIAGNOSIS >

[VDC/TCS/ABS]

3. CHECK STOP LAMP RELAY CIRCUIT FOR OPEN

1. Disconnect stop lamp relay connector.
2. Check continuity between ABS actuator and electric unit (control unit) connector E125 terminal 5 and stop lamp relay connector E39 terminal 5.

ABS actuator and electric unit (control unit)		Stop lamp relay		Continuity
Connector	Terminal	Connector	Terminal	
E125	5	E39	5	Yes

Is the inspection result normal?

YES >> GO TO 4.

NO >> Repair or replace as necessary.

4. CHECK STOP LAMP RELAY CIRCUIT FOR SHORT

Check continuity between ABS actuator and electric unit (control unit) connector E125 terminal 5 and ground.

ABS actuator and electric unit (control unit)		Ground	Continuity
Connector	Terminal		
E125	5	—	No

Is the inspection result normal?

YES >> Refer to [EXL-103. "Work Flow"](#).

NO >> Repair harness or connectors.

C1120, C1122, C1124, C1126 ABS IN VALVE SYSTEM

< DTC/CIRCUIT DIAGNOSIS >

[VDC/TCS/ABS]

C1120, C1122, C1124, C1126 ABS IN VALVE SYSTEM

DTC Logic

INFOID:000000009177283

DTC DETECTION LOGIC

DTC	Display Item	Malfunction detected condition	Possible causes
C1120	FR LH IN ABS SOL	When a malfunction is detected in front LH ABS IN valve.	<ul style="list-style-type: none">• Harness or connector• ABS actuator and electric unit (control unit)• Fusible link• Battery power supply system
C1122	FR RH IN ABS SOL	When a malfunction is detected in front RH ABS IN valve.	
C1124	RR LH IN ABS SOL	When a malfunction is detected in rear LH ABS IN valve.	
C1126	RR RH IN ABS SOL	When a malfunction is detected in rear RH ABS IN valve.	

DTC CONFIRMATION PROCEDURE

1. CHECK SELF-DIAGNOSTIC RESULT

④ With CONSULT.

1. Turn ignition switch OFF to ON.
2. Perform self-diagnostic result.

Is DTC C1120, C1122, C1124 or C1126 detected?

- YES >> Proceed to diagnosis procedure. Refer to [BRC-73, "Diagnosis Procedure"](#).
NO >> Inspection End.

Diagnosis Procedure

INFOID:000000009177284

Regarding Wiring Diagram information, refer to [BRC-44, "Wiring Diagram"](#).

1. CONNECTOR INSPECTION

1. Turn ignition switch OFF.
2. Disconnect ABS actuator and electric unit (control unit) connectors.
3. Check connectors and terminals for deformation, disconnection, looseness or damage.

Is the inspection result normal?

- YES >> GO TO 2.
NO >> Repair or replace as necessary.

2. CHECK ABS ACTUATOR AND ELECTRIC UNIT (CONTROL UNIT) BATTERY POWER SUPPLY

Check voltage between ABS actuator and electric unit (control unit) connector E125 terminal 3 and ground.

ABS actuator and electric unit (control unit)		—	Voltage (Approx.)
Connector	Terminal		
E125	3	Ground	Battery voltage

Is the inspection result normal?

- YES >> GO TO 3.
NO >> Repair or replace malfunctioning components.

3. CHECK ABS ACTUATOR AND ELECTRIC UNIT (CONTROL UNIT) GROUND CIRCUIT

Check continuity between ABS actuator and electric unit (control unit) connector E125 terminals 1, 2 and ground.

C1120, C1122, C1124, C1126 ABS IN VALVE SYSTEM

< DTC/CIRCUIT DIAGNOSIS >

[VDC/TCS/ABS]

ABS actuator and electric unit (control unit)		—	Continuity
Connector	Terminal		
E125	1	Ground	Yes
	2		

Is the inspection result normal?

YES >> Replace ABS actuator and electric unit (control unit). Refer to [BRC-123, "Removal and Installation"](#).

NO >> Repair or replace malfunctioning components.

C1121, C1123, C1125, C1127 ABS OUT VALVE SYSTEM

< DTC/CIRCUIT DIAGNOSIS >

[VDC/TCS/ABS]

C1121, C1123, C1125, C1127 ABS OUT VALVE SYSTEM

DTC Logic

INFOID:000000009177285

DTC DETECTION LOGIC

DTC	Display Item	Malfunction detected condition	Possible causes
C1121	FR LH OUT ABS SOL	When a malfunction is detected in front LH ABS OUT valve.	<ul style="list-style-type: none"> • Harness or connector • ABS actuator and electric unit (control unit) • Fusible link • Battery power supply system
C1123	FR RH OUT ABS SOL	When a malfunction is detected in front RH ABS OUT valve.	
C1125	RR LH OUT ABS SOL	When a malfunction is detected in rear LH ABS OUT valve.	
C1127	RR RH OUT ABS SOL	When a malfunction is detected in rear RH ABS OUT valve.	

DTC CONFIRMATION PROCEDURE

1. CHECK SELF-DIAGNOSTIC RESULT

 With CONSULT.

1. Turn ignition switch OFF to ON.
2. Perform self-diagnostic result.

Is DTC C1121, C1123, C1125 or C1127 detected?

- YES >> Proceed to diagnosis procedure. Refer to [BRC-75, "Diagnosis Procedure"](#).
 NO >> Inspection End.

Diagnosis Procedure

INFOID:000000009177286

Regarding Wiring Diagram information, refer to [BRC-44, "Wiring Diagram"](#).

1. CONNECTOR INSPECTION

1. Turn ignition switch OFF.
2. Disconnect ABS actuator and electric unit (control unit) connectors.
3. Check connectors and terminals for deformation, disconnection, looseness or damage.

Is the inspection result normal?

- YES >> GO TO 2.
 NO >> Repair or replace as necessary.

2. CHECK ABS ACTUATOR AND ELECTRIC UNIT (CONTROL UNIT) BATTERY POWER SUPPLY

Check voltage between ABS actuator and electric unit (control unit) connector E125 terminal 3 and ground.

ABS actuator and electric unit (control unit)		—	Voltage (Approx.)
Connector	Terminal		
E125	3	Ground	Battery voltage

Is the inspection result normal?

- YES >> GO TO 3.
 NO >> Repair or replace malfunctioning components.

3. CHECK ABS ACTUATOR AND ELECTRIC UNIT (CONTROL UNIT) GROUND CIRCUIT

Check continuity between ABS actuator and electric unit (control unit) connector E125 terminals 1, 2 and ground.

C1121, C1123, C1125, C1127 ABS OUT VALVE SYSTEM

< DTC/CIRCUIT DIAGNOSIS >

[VDC/TCS/ABS]

ABS actuator and electric unit (control unit)		—	Continuity
Connector	Terminal		
E125	1	Ground	Yes
	2		

Is the inspection result normal?

YES >> Replace ABS actuator and electric unit (control unit). Refer to [BRC-123, "Removal and Installation"](#).

NO >> Repair or replace malfunctioning components.

C1130 ENGINE SIGNAL

< DTC/CIRCUIT DIAGNOSIS >

[VDC/TCS/ABS]

C1130 ENGINE SIGNAL

DTC Logic

INFOID:000000009177287

DTC DETECTION LOGIC

DTC	Display Item	Malfunction detected condition	Possible causes
C1130	ENGINE SIGNAL 1	When a malfunction is detected in ECM system.	<ul style="list-style-type: none">• ECM• ABS actuator and electric unit (control unit)• CAN communication line

DTC CONFIRMATION PROCEDURE

1. CHECK SELF-DIAGNOSTIC RESULT

Ⓜ With CONSULT.

1. Turn ignition switch OFF to ON.
2. Perform self-diagnostic result.

Is DTC C1130 detected?

- YES >> Proceed to diagnosis procedure. Refer to [BRC-77, "Diagnosis Procedure"](#).
NO >> Inspection End.

Diagnosis Procedure

INFOID:000000009177288

1. CHECK SELF-DIAGNOSTIC RESULT FOR ENGINE SYSTEM

Ⓜ With CONSULT.

Perform self-diagnostic result. Refer to [EC-61, "CONSULT Function"](#).

Are any ECM DTCs detected?

- YES >> Refer to [EC-91, "DTC Index"](#).
NO >> GO TO 2.

2. CHECK SELF-DIAGNOSTIC RESULT FOR ABS ACTUATOR AND ELECTRIC UNIT (CONTROL UNIT)

Ⓜ With CONSULT.

1. Perform self-diagnostic result and erase DTCs.
2. Turn ignition switch OFF.
3. Start engine and drive vehicle for a short period of time.
4. Check that malfunction indicator lamp (MIL) turns OFF.
5. Stop vehicle and perform self-diagnostic result.

Is DTC C1130 detected?

- YES >> Replace ABS actuator and electric unit (control unit). Refer to [BRC-123, "Removal and Installation"](#).
NO >> Check pin terminals and connection of connectors for abnormal conditions. Repair or replace malfunctioning components.

C1140 ACTUATOR RELAY SYSTEM

< DTC/CIRCUIT DIAGNOSIS >

[VDC/TCS/ABS]

C1140 ACTUATOR RELAY SYSTEM

DTC Logic

INFOID:000000009177289

DTC DETECTION LOGIC

DTC	Display Item	Malfunction detected condition	Possible causes
C1140	ACTUATOR RLY	When a malfunction is detected in actuator relay.	<ul style="list-style-type: none">• Harness or connector• ABS actuator and electric unit (control unit)• Fusible link• Battery power supply system

DTC CONFIRMATION PROCEDURE

1. CHECK SELF-DIAGNOSTIC RESULT

Ⓜ With CONSULT.

1. Turn ignition switch OFF to ON.
2. Perform self-diagnostic result.

Is DTC C1140 detected?

- YES >> Proceed to diagnosis procedure. Refer to [BRC-78, "Diagnosis Procedure"](#).
NO >> Inspection End.

Diagnosis Procedure

INFOID:000000009177290

Regarding Wiring Diagram information, refer to [BRC-44, "Wiring Diagram"](#).

1. CONNECTOR INSPECTION

1. Turn ignition switch OFF.
2. Disconnect ABS actuator and electric unit (control unit) connectors.
3. Check connectors and terminals for deformation, disconnection, looseness or damage.

Is the inspection result normal?

- YES >> GO TO 2.
NO >> Repair or replace as necessary.

2. CHECK ABS ACTUATOR AND ELECTRIC UNIT (CONTROL UNIT) BATTERY POWER SUPPLY

Check voltage between ABS actuator and electric unit (control unit) connector E125 terminals 3, 4 and ground.

ABS actuator and electric unit (control unit)		—	Voltage (Approx.)
Connector	Terminal		
E125	3	Ground	Battery voltage
	4		

Is the inspection result normal?

- YES >> GO TO 3.
NO >> Repair or replace malfunctioning components.

3. CHECK ABS ACTUATOR AND ELECTRIC UNIT (CONTROL UNIT) GROUND CIRCUIT

Check continuity between ABS actuator and electric unit (control unit) connector E125 terminals 1, 2 and ground.

C1140 ACTUATOR RELAY SYSTEM

< DTC/CIRCUIT DIAGNOSIS >

[VDC/TCS/ABS]

ABS actuator and electric unit (control unit)		—	Continuity
Connector	Terminal		
E125	1	Ground	Yes
	2		

Is the inspection result normal?

- YES >> Replace ABS actuator and electric unit (control unit). Refer to [BRC-123, "Removal and Installation"](#).
- NO >> Repair or replace malfunctioning components.

A
B
C
D
E
G
H
I
J
K
L
M
N
O
P

BRC

C1142 PRESS SENSOR

[VDC/TCS/ABS]

< DTC/CIRCUIT DIAGNOSIS >

C1142 PRESS SENSOR

DTC Logic

INFOID:000000009177291

DTC DETECTION LOGIC

DTC	Display Item	Malfunction detected condition	Possible causes
C1142	PRESS SEN CIRCUIT	When a malfunction is detected in master cylinder pressure sensor.	<ul style="list-style-type: none">• Stop lamp switch system• ABS actuator and electric unit (control unit)• Brake system

DTC CONFIRMATION PROCEDURE

1. CHECK SELF-DIAGNOSTIC RESULT

Ⓜ With CONSULT.

1. Turn ignition switch OFF to ON.
2. Perform self-diagnostic result.

Is DTC C1142 detected?

- YES >> Proceed to diagnosis procedure. Refer to [BRC-80, "Diagnosis Procedure"](#).
NO >> Inspection End.

Diagnosis Procedure

INFOID:000000009177292

1. CHECK STOP LAMP SWITCH SYSTEM

Check stop lamp switch system. Refer to [BRC-71, "Diagnosis Procedure"](#).

Is the inspection result normal?

- YES >> GO TO 2.
NO >> Repair or replace malfunctioning components.

2. CHECK BRAKE FLUID LEAKAGE

Check brake fluid leakage. Refer to [BR-8, "Inspection"](#).

Is the inspection result normal?

- YES >> GO TO 3.
NO >> Repair or replace malfunctioning components.

3. CHECK BRAKE PEDAL

Check brake pedal. Refer to [BR-7, "Inspection"](#).

Is the inspection result normal?

- YES >> GO TO 4.
NO >> Repair or replace malfunctioning components.

4. CHECK HYDRAULIC BOOSTER ASSEMBLY

Check hydraulic booster assembly. Refer to [BR-10, "Inspection"](#).

Is the inspection result normal?

- YES >> GO TO 5.
NO >> Repair or replace malfunctioning components.

5. CHECK SELF DIAGNOSTIC RESULT

Ⓜ With CONSULT.

1. Turn ignition switch OFF to ON.
2. Perform self-diagnostic result.
3. Erase DTCs.
4. Start engine and drive vehicle for a short period of time.
5. Turn ignition switch OFF to ON.

C1142 PRESS SENSOR

[VDC/TCS/ABS]

< DTC/CIRCUIT DIAGNOSIS >

6. Perform self-diagnostic result.

Is DTC C1142 detected?

YES >> Replace ABS actuator and electric unit (control unit). Refer to [BRC-123. "Removal and Installation"](#)

NO >> Inspection End.

A
B
C
D
E
G
H
I
J
K
L
M
N
O
P

BRC

C1143 STEERING ANGLE SENSOR

< DTC/CIRCUIT DIAGNOSIS >

[VDC/TCS/ABS]

C1143 STEERING ANGLE SENSOR

DTC Logic

INFOID:000000009177293

DTC DETECTION LOGIC

DTC	Display Item	Malfunction detected condition	Possible causes
C1143	ST ANG SEN CIRCUIT	When a malfunction is detected in steering angle sensor.	<ul style="list-style-type: none">• Harness or connector• Steering angle sensor• ABS actuator and electric unit (control unit)• Fuse• Ignition power supply system• CAN communication line

DTC CONFIRMATION PROCEDURE

1.CHECK SELF-DIAGNOSTIC RESULT

Ⓢ With CONSULT.

1. Turn ignition switch OFF to ON.
2. Perform self-diagnostic result.

Is DTC C1143 detected?

- YES >> Proceed to diagnosis procedure. Refer to [BRC-82, "Diagnosis Procedure"](#).
NO >> Inspection End.

Diagnosis Procedure

INFOID:000000009177294

Regarding Wiring Diagram information, refer to [BRC-44, "Wiring Diagram"](#).

1.CONNECTOR INSPECTION

1. Turn ignition switch OFF.
2. Disconnect ABS actuator and electric unit (control unit) and steering angle sensor connectors.
3. Check connectors and terminals for deformation, disconnection, looseness or damage.

Is the inspection result normal?

- YES >> GO TO 2.
NO >> Repair or replace as necessary.

2.CHECK STEERING ANGLE SENSOR MOUNTING CONDITION

Check steering angle sensor mounting condition.

Is the inspection result normal?

- YES >> GO TO 3.
NO >> Repair or replace malfunctioning components.

3.CHECK STEERING ANGLE SENSOR POWER SUPPLY

1. Turn ignition switch OFF.
2. Disconnect steering angle sensor connector.
3. Turn ignition switch ON.
4. Check voltage between steering angle sensor connector M54 terminal 4 and ground.

Steering angle sensor		—	Voltage (Approx.)
Connector	Terminal		
M54	4	Ground	Battery voltage

Is the inspection result normal?

- YES >> GO TO 5.

C1143 STEERING ANGLE SENSOR

[VDC/TCS/ABS]

< DTC/CIRCUIT DIAGNOSIS >

NO >> GO TO 4.

4.CHECK STEERING ANGLE SENSOR POWER SUPPLY CIRCUIT

1. Turn ignition switch OFF.
2. Disconnect IPDM E/R connector E119.
3. Check continuity between steering angle sensor connector M54 terminal 4 and IPDM E/R connector E119 terminal 35.

Steering angle sensor		IPDM E/R		Continuity
Connector	Terminal	Connector	Terminal	
M54	4	E119	35	Yes

4. Check continuity between steering angle sensor connector M54 terminal 4 and ground.

Steering angle sensor		—	Continuity
Connector	Terminal		
M54	4	Ground	No

Is the inspection result normal?

YES >> Perform trouble diagnosis for ignition power supply.

NO >> Repair or replace malfunctioning components.

5.CHECK STEERING ANGLE SENSOR GROUND CIRCUIT

1. Turn ignition switch OFF.
2. Check continuity between steering angle sensor connector M54 terminal 1 and ground.

Steering angle sensor		—	Continuity
Connector	Terminal		
M54	1	Ground	Yes

Is the inspection result normal?

YES >> GO TO 6.

NO >> Repair or replace malfunctioning components.

6.CHECK CAN COMMUNICATION LINE

Check "STRG BRANCH LINE CIRCUIT". Refer to [LAN-121, "Diagnosis Procedure"](#) (Type 1) or [LAN-138, "Diagnosis Procedure"](#) (Type 2).

Is the inspection result normal?

YES >> Replace ABS actuator and electric unit (control unit). Refer to [BRC-123, "Removal and Installation"](#).

NO >> Repair or replace malfunctioning components.

C1144 INCOMPLETE STEERING ANGLE SENSOR ADJUSTMENT

< DTC/CIRCUIT DIAGNOSIS >

[VDC/TCS/ABS]

C1144 INCOMPLETE STEERING ANGLE SENSOR ADJUSTMENT

DTC Logic

INFOID:000000009177295

DTC DETECTION LOGIC

DTC	Display Item	Malfunction detected condition	Possible causes
C1144	ST ANG SEN SIGNAL	When neutral position adjustment of steering angle sensor is not complete.	<ul style="list-style-type: none">• Harness or connector• Steering angle sensor• ABS actuator and electric unit (control unit)• Incomplete neutral position adjustment of steering angle sensor

DTC CONFIRMATION PROCEDURE

1. CHECK SELF-DIAGNOSTIC RESULT

Ⓢ With CONSULT.

1. Turn ignition switch OFF to ON.
2. Perform self-diagnostic result.

Is DTC C1144 detected?

- YES >> Proceed to diagnosis procedure. Refer to [BRC-84, "Diagnosis Procedure"](#).
NO >> Inspection End.

Diagnosis Procedure

INFOID:000000009177296

1. ADJUST THE NEUTRAL POSITION OF STEERING ANGLE SENSOR

Perform neutral position adjustment of steering angle sensor. Refer to [BRC-55, "Work Procedure"](#).

>> GO TO 2.

2. CHECK SELF-DIAGNOSTIC RESULT

Ⓢ With CONSULT.

Perform self-diagnostic result.

Is DTC C1144 detected?

- YES >> GO TO 3.
NO >> Inspection End.

3. CHECK STEERING ANGLE SENSOR SYSTEM

Check steering angle sensor system. Refer to [BRC-82, "Diagnosis Procedure"](#).

Is the inspection result normal?

- YES >> Replace ABS actuator and electric unit (control unit). Refer to [BRC-123, "Removal and Installation"](#).
NO >> Repair or replace malfunctioning components.

C1145, C1146 YAW RATE/SIDE/DECEL G SENSOR

< DTC/CIRCUIT DIAGNOSIS >

[VDC/TCS/ABS]

C1145, C1146 YAW RATE/SIDE/DECEL G SENSOR

DTC Logic

INFOID:000000009177297

DTC DETECTION LOGIC

DTC	Display Item	Malfunction detected condition	Possible causes
C1145	YAW RATE SENSOR	<ul style="list-style-type: none">When a malfunction is detected in yaw rate signal.When yaw rate signal is not continuously received for 2 seconds or more.When side G signal is not continuously received for 2 seconds or more.When decel G signal is not continuously received for 2 seconds or more.	<ul style="list-style-type: none">Harness or connectorYaw rate/side/decel G sensorABS actuator and electric unit (control unit)Ignition power supply systemFuse
C1146	SIDE G-SEN CIRCUIT	When a malfunction is detected in side/decel G signal.	

DTC CONFIRMATION PROCEDURE

1. CHECK SELF-DIAGNOSTIC RESULT

Ⓜ With CONSULT.

- Turn ignition switch OFF to ON.
- Perform self-diagnostic result.

Is DTC C1145 or C1146 detected?

- YES >> Proceed to diagnosis procedure. Refer to [BRC-85. "Diagnosis Procedure"](#).
NO >> Inspection End.

Diagnosis Procedure

INFOID:000000009177298

Regarding Wiring Diagram information, refer to [BRC-44. "Wiring Diagram"](#).

CAUTION:

- A malfunction in yaw rate/side/decel G sensor system may be detected when the vehicle sharply turns during a spin turn, acceleration turn or drift driving while VDC function is OFF (VDC OFF indicator lamp is in ON status). This is not a malfunction if the status returns to normal after engine is started again. In that case, erase self-diagnosis result memory using CONSULT.
- When the engine is in running status and the vehicle is on a turntable at the entrance of parking lot or on a moving unit, SLIP indicator lamp may turn ON and "ABS" self-diagnosis may display "YAW RATE SENSOR". In this case, yaw rate sensor is not malfunctioning. The status returns to normal when the vehicle leaves the turntable or moving unit and the engine is started again. In that case, erase self-diagnosis result memory using CONSULT.

1. CONNECTOR INSPECTION

- Turn ignition switch OFF.
- Disconnect ABS actuator and electric unit (control unit) and yaw rate/side/decel G sensor connectors.
- Check connectors and terminals for deformation, disconnection, looseness or damage.

Is the inspection result normal?

- YES >> GO TO 2.
NO >> Repair or replace as necessary.

2. CHECK YAW RATE/SIDE/DECEL G SENSOR MOUNTING CONDITION

Check yaw rate/side/decel G sensor mounting condition. Refer to [BRC-125. "Exploded View"](#).

Is the inspection result normal?

- YES >> GO TO 3.
NO >> Repair or replace malfunctioning components.

3. CHECK YAW RATE/SIDE/DECEL G SENSOR POWER SUPPLY

C1145, C1146 YAW RATE/SIDE/DECCEL G SENSOR

< DTC/CIRCUIT DIAGNOSIS >

[VDC/TCS/ABS]

1. Turn ignition switch OFF.
2. Disconnect yaw rate/side/decel G sensor connector.
3. Turn the ignition switch ON.
4. Check voltage between yaw rate/side/decel G sensor connector M160 terminal 4 and ground.

Yaw rate/side/decel G sensor		—	Voltage (Approx.)
Connector	Terminal		
M160	4	Ground	Battery voltage

Is the inspection result normal?

YES >> GO TO 4.

NO >> Repair circuit between splice and yaw rate/side/decel G sensor terminal 4.

4.CHECK YAW RATE/SIDE/DECCEL G SENSOR GROUND CIRCUIT

1. Turn ignition switch OFF.
2. Check continuity between yaw rate/side/decel G sensor connector M160 terminal 1 and ground.

Yaw rate/side/decel G sensor		—	Continuity
Connector	Terminal		
M160	1	Ground	Yes

Is the inspection result normal?

YES >> GO TO 5.

NO >> Repair or replace malfunctioning components.

5.CHECK COMMUNICATION LINES

1. Disconnect ABS actuator and electric unit (control unit) connector E125.
2. Check continuity between yaw rate/side/decel G sensor connector M160 terminals 2, 3 and ABS actuator and electric unit (control unit) connector E125 terminals 6, 16.

Yaw rate/side/decel G sensor		ABS actuator and electric unit (control unit)		Continuity
Connector	Terminal	Connector	Terminal	
M160	2	E125	6	Yes
	3		16	

3. Check continuity between yaw rate/side/decel G sensor connector M160 terminals 2, 3 and ground.

Yaw rate/side/decel G sensor		Ground	Continuity
Connector	Terminal		
M160	2	—	No
	3		

Is the inspection result normal?

YES >> GO TO 6.

NO >> Repair or replace malfunctioning components.

6.CHECK COMMUNICATION LINES RESISTANCE

1. Connect ABS actuator and electric unit (control unit) connector E125.
2. Check resistance between yaw rate/side/decel G sensor connector M160 terminals 2, 3.

Yaw rate/side/decel G sensor		Resistance
Connector	Terminal	
M160	2	100 – 140 Ω
	3	

Is the inspection result normal?

C1145, C1146 YAW RATE/SIDE/DECEL G SENSOR

< DTC/CIRCUIT DIAGNOSIS >

[VDC/TCS/ABS]

YES >> Replace yaw rate/side/decel G sensor. Refer to [BRC-123, "Removal and Installation"](#).
NO >> Replace ABS actuator and electric unit (control unit). Refer to [BRC-123, "Removal and Installation"](#).

A
B
C
D
E
G
H
I
J
K
L
M
N
O
P

BRC

C1155 BRAKE FLUID LEVEL SWITCH

< DTC/CIRCUIT DIAGNOSIS >

[VDC/TCS/ABS]

C1155 BRAKE FLUID LEVEL SWITCH

DTC Logic

INFOID:000000009177299

DTC DETECTION LOGIC

DTC	Display Item	Malfunction detected condition	Possible causes
C1155	BR FLUID LEVEL LOW	When brake fluid level low signal is detected.	<ul style="list-style-type: none">• Harness or connector• ABS actuator and electric unit (control unit)• Brake fluid level switch• Combination meter

DTC CONFIRMATION PROCEDURE

1. CHECK SELF-DIAGNOSTIC RESULT

Ⓟ With CONSULT.

1. Turn ignition switch OFF to ON and wait 1 minute or more.
2. Perform self-diagnostic result.

Is DTC C1155 detected?

- YES >> Proceed to diagnosis procedure. Refer to [BRC-88, "Diagnosis Procedure"](#).
NO >> Inspection End.

Diagnosis Procedure

INFOID:000000009177300

Regarding Wiring Diagram information, refer to [BRC-44, "Wiring Diagram"](#).

1. CHECK BRAKE FLUID LEVEL

1. Turn the ignition switch OFF.
2. Check brake fluid level. Refer to [BR-8, "Inspection"](#).

Is the inspection result normal?

- YES >> GO TO 2.
NO >> Refill brake fluid. Refer to [BR-16, "Drain and Refill"](#).

2. CONNECTOR INSPECTION

1. Turn ignition switch OFF.
2. Disconnect combination meter connector M24 and brake fluid level switch connector E21.
3. Check connectors and terminals for deformation, disconnection, looseness or damage.

Is the inspection result normal?

- YES >> GO TO 3.
NO >> Repair or replace as necessary.

3. CHECK BRAKE FLUID LEVEL SWITCH

Check brake fluid level switch. Refer to [BRC-89, "Component Inspection"](#).

Is the inspection result normal?

- YES >> GO TO 4.
NO >> Replace reservoir tank. Refer to [BR-29, "Disassembly and Assembly"](#).

4. CHECK BRAKE FLUID LEVEL SWITCH CIRCUIT

1. Turn the ignition switch OFF.
2. Disconnect brake fluid level switch harness connector.
3. Disconnect combination meter harness connector.
4. Check continuity between brake fluid level switch harness connector and combination meter harness connector.

C1155 BRAKE FLUID LEVEL SWITCH

< DTC/CIRCUIT DIAGNOSIS >

[VDC/TCS/ABS]

Brake fluid level switch		Combination meter		Continuity
Connector	Terminal	Connector	Terminal	
E21	1	M24	25	Yes

5. Check continuity between brake fluid level switch harness connector and ground.

Brake fluid level switch		—	Continuity
Connector	Terminal		
E21	1	Ground	No

Is the inspection result normal?

YES >> GO TO 5.

NO >> Repair or replace malfunctioning components.

5.CHECK BRAKE FLUID LEVEL SWITCH GROUND CIRCUIT

Check continuity between brake fluid level switch harness connector and ground.

Brake fluid level switch		—	Continuity
Connector	Terminal		
E21	2	Ground	Yes

Is the inspection result normal?

YES >> GO TO 6.

NO >> Repair or replace malfunctioning components.

6.CHECK COMBINATION METER

Check if indication and operation of combination meter are normal. Refer to [MWI-9, "METER SYSTEM : System Description"](#).

Is the inspection result normal?

YES >> Replace ABS actuator and electric unit (control unit). Refer to [BRC-123, "Removal and Installation"](#).

NO >> Replace combination meter. Refer to [MWI-82, "Removal and Installation"](#).

Component Inspection

INFOID:000000009177301

1.CHECK BRAKE FLUID LEVEL SWITCH

1. Turn the ignition switch OFF.
2. Disconnect brake fluid level switch harness connector.
3. Check continuity between terminals of brake fluid level switch.

Brake fluid level switch	Condition	Continuity
Terminal		
1 – 2	When brake fluid level in reservoir tank is within the specified level.	No
	When brake fluid level in reservoir tank is less than the specified level.	Yes

Is the inspection result normal?

YES >> Inspection End.

NO >> Replace reservoir tank. Refer to [BR-29, "Disassembly and Assembly"](#).

C1160 DECEL G SEN SET

< DTC/CIRCUIT DIAGNOSIS >

[VDC/TCS/ABS]

C1160 DECEL G SEN SET

DTC Logic

INFOID:000000009177302

DTC DETECTION LOGIC

DTC	Display Item	Malfunction detected condition	Possible causes
C1160	DECEL G SEN SET	When calibration of yaw rate/side/decel G sensor is not complete.	<ul style="list-style-type: none">• Yaw rate/side/decel G sensor• Harness or connector• ABS actuator and electric unit (control unit)• Decel G sensor calibration is not performed

DTC CONFIRMATION PROCEDURE

1.CHECK SELF-DIAGNOSTIC RESULT

ⓂWith CONSULT.

1. Turn ignition switch OFF to ON.
2. Perform self-diagnostic result.

Is DTC C1160 detected?

- YES >> Proceed to diagnosis procedure. Refer to [BRC-90, "Diagnosis Procedure"](#).
NO >> Inspection End.

Diagnosis Procedure

INFOID:000000009177303

1.DECEL G SENSOR CALIBRATION

Perform decel G sensor calibration. Refer to [BRC-57, "Work Procedure"](#).

>> GO TO 2.

2.CHECK SELF-DIAGNOSTIC RESULT

ⓂWith CONSULT.

Perform self-diagnostic result.

Is DTC C1160 detected?

- YES >> GO TO 3.
NO >> Inspection End.

3.CHECK YAW RATE/SIDE/DECEL G SENSOR SYSTEM

Check yaw rate/side/decel G sensor system. Refer to [BRC-85, "Diagnosis Procedure"](#).

Is the inspection result normal?

- YES >> Replace ABS actuator and electric unit (control unit). Refer to [BRC-123, "Removal and Installation"](#).
NO >> Repair or replace malfunctioning components.

C1164, C1165 CV SYSTEM

< DTC/CIRCUIT DIAGNOSIS >

[VDC/TCS/ABS]

C1164, C1165 CV SYSTEM

DTC Logic

INFOID:000000009177304

DTC DETECTION LOGIC

DTC	Display Item	Malfunction detected condition	Possible causes
C1164	CV 1	When a malfunction is detected in cut valve 1.	<ul style="list-style-type: none">• Harness or connector• ABS actuator and electric unit (control unit)• Fusible link• Battery power supply system
C1165	CV 2	When a malfunction is detected in cut valve 2.	

DTC CONFIRMATION PROCEDURE

1. CHECK SELF-DIAGNOSTIC RESULT

Ⓟ With CONSULT.

1. Turn ignition switch ON.
2. Perform self-diagnostic result.

Is DTC "C1164" or "C1165" detected?

- YES >> Proceed to diagnosis procedure. Refer to [BRC-91, "Diagnosis Procedure"](#).
NO >> Inspection End.

Diagnosis Procedure

INFOID:000000009177305

Regarding Wiring Diagram information, refer to [BRC-44, "Wiring Diagram"](#).

1. CONNECTOR INSPECTION

1. Turn ignition switch OFF.
2. Disconnect ABS actuator and electric unit (control unit) connectors.
3. Check connectors and terminals for deformation, disconnection, looseness or damage.

Is the inspection result normal?

- YES >> GO TO 2.
NO >> Repair or replace as necessary.

2. CHECK ABS ACTUATOR AND ELECTRIC UNIT (CONTROL UNIT) BATTERY POWER SUPPLY

Check voltage between ABS actuator and electric unit (control unit) connector E125 terminals 3, 4 and ground.

ABS actuator and electric unit (control unit)		—	Voltage (Approx.)
Connector	Terminal		
E125	3	Ground	Battery voltage
	4		

Is the inspection result normal?

- YES >> GO TO 3.
NO >> Repair or replace malfunctioning components.

3. CHECK ABS ACTUATOR AND ELECTRIC UNIT (CONTROL UNIT) GROUND CIRCUIT

Check continuity between ABS actuator and electric unit (control unit) connector E125 terminals 1, 2 and ground.

C1164, C1165 CV SYSTEM

< DTC/CIRCUIT DIAGNOSIS >

[VDC/TCS/ABS]

ABS actuator and electric unit (control unit)		—	Continuity
Connector	Terminal		
E125	1	Ground	Yes
	2		

Is the inspection result normal?

YES >> Replace ABS actuator and electric unit (control unit). Refer to [BRC-123, "Removal and Installation"](#).

NO >> Repair or replace malfunctioning components.

C1170 VARIANT CODING

< DTC/CIRCUIT DIAGNOSIS >

[VDC/TCS/ABS]

C1170 VARIANT CODING

DTC Logic

INFOID:000000009177306

DTC DETECTION LOGIC

DTC	Display Item	Malfunction detected condition	Possible causes
C1170	VARIANT CODING	When the information in ABS actuator and electric unit (control unit) is not the same.	ABS actuator and electric unit (control unit)

DTC CONFIRMATION PROCEDURE

1. CHECK SELF-DIAGNOSTIC RESULT

 With CONSULT.

1. Turn ignition switch ON.
2. Perform self-diagnostic result.

Is DTC C1170 detected?

- YES >> Proceed to diagnosis procedure. Refer to [BRC-93, "Diagnosis Procedure"](#).
- NO >> Inspection End.

Diagnosis Procedure

INFOID:000000009177307

1. REPLACE ABS ACTUATOR AND ELECTRIC UNIT (CONTROL UNIT)

Replace ABS actuator and electric unit (control unit) even if other DTCs are displayed with "VARIANT CODING" in self diagnostic result.

- >> Replace ABS actuator and electric unit (control unit). Refer to [BRC-123, "Removal and Installation"](#).

C1197 VACUUM SENSOR

< DTC/CIRCUIT DIAGNOSIS >

[VDC/TCS/ABS]

C1197 VACUUM SENSOR

DTC Logic

INFOID:000000009177308

DTC DETECTION LOGIC

DTC	Display Item	Malfunction detected condition	Possible causes
C1197	VACUUM SENSOR	When a malfunction is detected in vacuum sensor.	<ul style="list-style-type: none">• Harness or connector• Vacuum sensor (brake booster)• Vacuum piping• ABS actuator and electric unit (control unit)

DTC CONFIRMATION PROCEDURE

1. CHECK SELF-DIAGNOSTIC RESULT

Ⓜ With CONSULT.

1. Turn the ignition switch ON.
2. Perform self-diagnostic result.

Is DTC C1197 detected?

- YES >> Proceed to diagnosis procedure. Refer to [BRC-94, "Diagnosis Procedure"](#).
NO >> Inspection End.

Diagnosis Procedure

INFOID:000000009177309

Regarding Wiring Diagram information, refer to [BRC-44, "Wiring Diagram"](#).

1. CHECK BRAKE BOOSTER

1. Turn the ignition switch OFF.
2. Check brake booster. Refer to [BR-10, "Inspection"](#).

Is the inspection result normal?

- YES >> GO TO 2.
NO >> Replace brake booster. Refer to [BR-31, "Removal and Installation"](#).

2. CHECK VACUUM PIPING

Check vacuum piping. Refer to [BR-33, "Exploded View"](#).

Is the inspection result normal?

- YES >> GO TO 3.
NO >> Replace vacuum piping. Refer to [BR-33, "Removal and Installation"](#).

3. CHECK VACUUM SENSOR CIRCUIT

1. Disconnect vacuum sensor harness connector.
2. Disconnect ABS actuator and electric unit (control unit) harness connector.
3. Check continuity between vacuum sensor harness connector and ABS actuator and electric unit (control unit) harness connector.

Vacuum sensor		ABS actuator and electric unit (control unit)		Continuity
Connector	Terminal	Connector	Terminal	
E167	1	E125	13	Yes
	2		32	
	3		28	

4. Check continuity between vacuum sensor harness connector and ground.

C1197 VACUUM SENSOR

< DTC/CIRCUIT DIAGNOSIS >

[VDC/TCS/ABS]

Vacuum sensor		—	Continuity
Connector	Terminal		
E167	1	Ground	No
	2		
	3		

Is the inspection result normal?

YES >> GO TO 4.

NO >> Repair or replace malfunctioning components.

4. CHECK TERMINAL

- Check vacuum sensor pin terminals for damage or loose connection with harness connector.
- Check ABS actuator and electric unit (control unit) pin terminals for damage or loose connection with harness connector.

Is the inspection result normal?

YES >> GO TO 5.

NO >> Repair or replace malfunctioning components.

5. REPLACE VACUUM SENSOR

Ⓜ With CONSULT

1. Connect ABS actuator and electric unit (control unit) harness connector.
2. Replace vacuum sensor. Refer to [BR-31, "Removal and Installation"](#).

CAUTION:

Always replace brake booster because vacuum sensor cannot be disassembled.

3. Erase self-diagnosis result for "ABS".
4. Turn the ignition switch OFF.
5. Start engine.
6. Perform self-diagnosis for "ABS".

Is DTC "C1197" detected?

YES >> Replace ABS actuator and electric unit (control unit). Refer to [BRC-123, "Removal and Installation"](#).

NO >> Inspection End.

A
B
C
D
E
G
H
I
J
K
L
M
N
O
P

BRC

C1198 VACUUM SENSOR

< DTC/CIRCUIT DIAGNOSIS >

[VDC/TCS/ABS]

C1198 VACUUM SENSOR

DTC Logic

INFOID:000000009177310

DTC DETECTION LOGIC

DTC	Display Item	Malfunction detected condition	Possible causes
C1198	VACUUM SEN CIR	<ul style="list-style-type: none">When an open circuit is detected in vacuum sensor circuit.When a short circuit is detected in vacuum sensor circuit.When a malfunction is detected in vacuum sensor noise.	<ul style="list-style-type: none">Harness or connectorVacuum sensor (brake booster)ABS actuator and electric unit (control unit)

DTC CONFIRMATION PROCEDURE

1. CHECK SELF-DIAGNOSTIC RESULT

Ⓜ With CONSULT.

- Turn the ignition switch ON.
- Perform self-diagnostic result.

Is DTC C1198 detected?

- YES >> Proceed to diagnosis procedure. Refer to [BRC-96, "Diagnosis Procedure"](#).
NO >> Inspection End.

Diagnosis Procedure

INFOID:000000009177311

Regarding Wiring Diagram information, refer to [BRC-44, "Wiring Diagram"](#).

1. CHECK VACUUM SENSOR CIRCUIT

- Turn the ignition switch OFF.
- Disconnect vacuum sensor harness connector.
- Disconnect ABS actuator and electric unit (control unit) harness connector.
- Check continuity between vacuum sensor harness connector and ABS actuator and electric unit (control unit) harness connector.

Vacuum sensor		ABS actuator and electric unit (control unit)		Continuity
Connector	Terminal	Connector	Terminal	
E167	1	E125	13	Yes
	2		32	
	3		28	

- Check continuity between vacuum sensor harness connector and ground.

Vacuum sensor		—	Continuity
Connector	Terminal		
E167	1	Ground	No
	2		
	3		

Is the inspection result normal?

- YES >> GO TO 2.
NO >> Repair or replace malfunctioning components.

2. CHECK TERMINAL

C1198 VACUUM SENSOR

[VDC/TCS/ABS]

< DTC/CIRCUIT DIAGNOSIS >

- Check vacuum sensor pin terminals for damage or loose connection with harness connector.
- Check ABS actuator and electric unit (control unit) pin terminals for damage or loose connection with harness connector.

Is the inspection result normal?

YES >> GO TO 3.

NO >> Repair or replace malfunctioning components.

3.REPLACE VACUUM SENSOR

ⓂWith CONSULT

1. Connect ABS actuator and electric unit (control unit) harness connector.
2. Replace vacuum sensor. Refer to [BR-31, "Removal and Installation"](#).

CAUTION:

Always replace brake booster because vacuum sensor cannot be disassembled.

3. Erase self-diagnosis result for "ABS".
4. Turn the ignition switch OFF.
5. Start engine.
6. Perform self-diagnosis for "ABS".

Is DTC "C1198" detected?

YES >> Replace ABS actuator and electric unit (control unit). Refer to [BRC-123, "Removal and Installation"](#).

NO >> Inspection End.

A
B
C
D
E
BRC
G
H
I
J
K
L
M
N
O
P

C1199 BRAKE BOOSTER

< DTC/CIRCUIT DIAGNOSIS >

[VDC/TCS/ABS]

C1199 BRAKE BOOSTER

DTC Logic

INFOID:000000009177312

DTC DETECTION LOGIC

DTC	Display Item	Malfunction detected condition	Possible causes
C1199	BRAKE BOOSTER	When brake booster vacuum is approx. 0 kPa (0 mm-Hg) during engine running.	<ul style="list-style-type: none">• Harness or connector• Vacuum sensor (brake booster)• Vacuum piping• ABS actuator and electric unit (control unit)

DTC CONFIRMATION PROCEDURE

1. CHECK SELF-DIAGNOSTIC RESULT

Ⓜ With CONSULT.

1. Turn the ignition switch ON.
2. Perform self-diagnostic result.

Is DTC C1199 detected?

- YES >> Proceed to diagnosis procedure. Refer to [BRC-98, "Diagnosis Procedure"](#).
NO >> Inspection End.

Diagnosis Procedure

INFOID:000000009177313

Regarding Wiring Diagram information, refer to [BRC-44, "Wiring Diagram"](#).

1. CHECK BRAKE BOOSTER

1. Turn the ignition switch OFF.
2. Check brake booster. Refer to [BR-10, "Inspection"](#).

Is the inspection result normal?

- YES >> GO TO 2.
NO >> Replace brake booster. Refer to [BR-31, "Removal and Installation"](#).

2. CHECK VACUUM PIPING

Check vacuum piping. Refer to [BR-33, "Exploded View"](#).

Is the inspection result normal?

- YES >> GO TO 3.
NO >> Replace vacuum piping. Refer to [BR-33, "Removal and Installation"](#).

3. CHECK VACUUM SENSOR CIRCUIT

1. Disconnect vacuum sensor harness connector.
2. Disconnect ABS actuator and electric unit (control unit) harness connector.
3. Check continuity between vacuum sensor harness connector and ABS actuator and electric unit (control unit) harness connector.

Vacuum sensor		ABS actuator and electric unit (control unit)		Continuity
Connector	Terminal	Connector	Terminal	
E167	1	E125	13	Yes
	2		32	
	3		28	

4. Check continuity between vacuum sensor harness connector and ground.

C1199 BRAKE BOOSTER

< DTC/CIRCUIT DIAGNOSIS >

[VDC/TCS/ABS]

Vacuum sensor		—	Continuity
Connector	Terminal		
E167	1	Ground	No
	2		
	3		

Is the inspection result normal?

YES >> GO TO 4.

NO >> Repair or replace malfunctioning components.

4. CHECK TERMINAL

- Check vacuum sensor pin terminals for damage or loose connection with harness connector.
- Check ABS actuator and electric unit (control unit) pin terminals for damage or loose connection with harness connector.

Is the inspection result normal?

YES >> GO TO 5.

NO >> Repair or replace malfunctioning components.

5. REPLACE VACUUM SENSOR

④ With CONSULT

1. Connect ABS actuator and electric unit (control unit) harness connector.
2. Replace vacuum sensor. Refer to [BR-31, "Removal and Installation"](#).

CAUTION:

Always replace brake booster because vacuum sensor cannot be disassembled.

3. Erase self-diagnosis result for "ABS".
4. Turn the ignition switch OFF.
5. Start engine.
6. Perform self-diagnosis for "ABS".

Is DTC "C1199" detected?

YES >> Replace ABS actuator and electric unit (control unit). Refer to [BRC-123, "Removal and Installation"](#).

NO >> Inspection End.

C119A VACUUM SENSOR

< DTC/CIRCUIT DIAGNOSIS >

[VDC/TCS/ABS]

C119A VACUUM SENSOR

DTC Logic

INFOID:000000009177314

DTC DETECTION LOGIC

DTC	Display Item	Malfunction detected condition	Possible causes
C119A	VACUUM SEN VOLT	When a malfunction is detected in supply power voltage of vacuum sensor.	<ul style="list-style-type: none">• Harness or connector• Vacuum sensor (brake booster)• ABS actuator and electric unit (control unit)

DTC CONFIRMATION PROCEDURE

1. CHECK SELF-DIAGNOSTIC RESULT

Ⓜ With CONSULT.

1. Turn the ignition switch ON.
2. Perform self-diagnostic result.

Is DTC C119A detected?

- YES >> Proceed to diagnosis procedure. Refer to [BRC-100. "Diagnosis Procedure"](#).
NO >> Inspection End.

Diagnosis Procedure

INFOID:000000009177315

Regarding Wiring Diagram information, refer to [BRC-44. "Wiring Diagram"](#).

1. CHECK VACUUM SENSOR POWER SUPPLY

1. Turn the ignition switch OFF.
2. Disconnect vacuum sensor harness connector.
3. Check voltage between vacuum sensor harness connector and ground.

Vacuum sensor		—	Voltage (Approx.)
Connector	Terminal		
E167	3	Ground	0 V

4. Turn the ignition switch ON.
CAUTION:
Never start engine.
5. Check voltage between vacuum sensor harness connector and ground.

Vacuum sensor		—	Voltage (Approx.)
Connector	Terminal		
E167	3	Ground	4.75 V – 5.25 V

Is the inspection result normal?

- YES >> GO TO 3.
NO >> GO TO 2.

2. CHECK VACUUM SENSOR POWER SUPPLY CIRCUIT

1. Turn the ignition switch OFF.
2. Disconnect ABS actuator and electric unit (control unit) harness connector.
3. Check continuity between vacuum sensor harness connector and ABS actuator and electric unit (control unit) harness connector.

C119A VACUUM SENSOR

< DTC/CIRCUIT DIAGNOSIS >

[VDC/TCS/ABS]

Vacuum sensor		ABS actuator and electric unit (control unit)		Continuity
Connector	Terminal	Connector	Terminal	
E167	3	E125	28	Yes

4. Check continuity between vacuum sensor harness connector and ground.

Vacuum sensor		—	Continuity
Connector	Terminal		
E167	3	Ground	No

Is the inspection result normal?

YES >> Perform diagnosis of ABS actuator and electric unit (control unit) power supply and ground circuit. Refer to [BRC-65, "Diagnosis Procedure"](#).

NO >> Repair or replace malfunctioning components.

3. CHECK VACUUM SENSOR GROUND CIRCUIT

1. Turn the ignition switch OFF.
2. Check continuity between vacuum sensor harness connector and ground.

Vacuum sensor		—	Continuity
Connector	Terminal		
E167	2	Ground	Yes

Is the inspection result normal?

YES >> GO TO 4.

NO >> Repair or replace malfunctioning components.

4. CHECK TERMINAL

- Check vacuum sensor pin terminals for damage or loose connection with harness connector.
- Check ABS actuator and electric unit (control unit) pin terminals for damage or loose connection with harness connector.

Is the inspection result normal?

YES >> Replace ABS actuator and electric unit (control unit). Refer to [BRC-123, "Removal and Installation"](#).

NO >> Repair or replace malfunctioning components.

A
B
C
D
E
BRC
G
H
I
J
K
L
M
N
O
P

U1000 CAN COMM CIRCUIT

< DTC/CIRCUIT DIAGNOSIS >

[VDC/TCS/ABS]

U1000 CAN COMM CIRCUIT

Description

INFOID:000000009177316

CAN communication allows a high rate of information transmission through the two communication lines (CAN-H line and CAN-L line) connecting various control units in the system. Each control unit transmits/receives data but selectively reads required data only.

DTC Logic

INFOID:000000009177317

DTC DETECTION LOGIC

DTC	Display Item	Malfunction detected condition	Possible causes
U1000	CAN COMM CIRCUIT	When CAN communication signal is not continuously received for 2 seconds or more	CAN communication system malfunction

Diagnosis Procedure

INFOID:000000009177318

1. CHECK SELF-DIAGNOSTIC RESULT

Ⓟ With CONSULT.

1. Turn ignition switch ON.
2. Perform self-diagnostic result.

Is DTC U1000 detected?

- YES >> Proceed to diagnosis procedure. Refer to [LAN-20, "Trouble Diagnosis Flow Chart"](#).
NO >> Refer to [GI-49, "Intermittent Incident"](#).

PARKING BRAKE SWITCH

< DTC/CIRCUIT DIAGNOSIS >

[VDC/TCS/ABS]

PARKING BRAKE SWITCH

Description

INFOID:000000009177319

Transmits the parking brake switch signal to the combination meter.

Component Function Check

INFOID:000000009177320

1.COMBINATION METER INPUT SIGNAL

1. Start engine.
2. Monitor BRAKE W/L in DATA MONITOR while applying and releasing the parking brake.

Condition **CONSULT**
Parking brake applied : **ON**
Parking brake released : **OFF**

>> Inspection End.

Diagnosis Procedure

INFOID:000000009177321

Regarding Wiring Diagram information, refer to [MWI-31, "Wiring Diagram"](#).

1.CHECK PARKING BRAKE SWITCH CIRCUIT

1. Disconnect combination meter harness connector M24 and parking brake switch harness connector E52.
2. Check continuity between combination meter harness connector M24 terminal 12 and parking brake switch harness connector E52 terminal 1.

Combination meter		Parking brake switch		Continuity
Connector	Terminal	Connector	Terminal	
M24	12	E52	1	Yes

3. Check continuity between combination meter harness connector M24 terminal 12 and ground.

Combination meter		Ground	Continuity
Connector	Terminal		
M24	12		No

Is the inspection result normal?

- YES >> Inspection End.
NO >> Repair or replace harness or connectors.

Component Inspection

INFOID:000000009177322

1.CHECK PARKING BRAKE SWITCH

Check continuity between parking brake switch terminal 1 and switch case ground.

Component	Terminal	Condition	Continuity
Parking brake switch	1	Parking brake applied	Yes
		Parking brake released	No

Is the inspection result normal?

- YES >> Inspection End.
NO >> Replace parking brake switch. Refer to [PB-7, "Exploded View"](#).

A
B
C
D
E
BRC

G
H
I
J
K
L
M
N
O
P

VDC OFF SWITCH

< DTC/CIRCUIT DIAGNOSIS >

[VDC/TCS/ABS]

VDC OFF SWITCH

Component Function Check

INFOID:000000009177323

1. CHECK VDC OFF SWITCH OPERATION

Check that VDC OFF indicator lamp in combination meter turns ON/OFF when VDC OFF switch is operated.

Is the inspection result normal?

YES >> Inspection End.

NO >> Proceed to diagnosis procedure. Refer to [BRC-104, "Diagnosis Procedure"](#).

Diagnosis Procedure

INFOID:000000009177324

Regarding Wiring Diagram information, refer to [BRC-44, "Wiring Diagram"](#).

1. CONNECTOR INSPECTION

1. Turn ignition switch OFF.
2. Disconnect ABS actuator and electric unit (control unit) connector E125 and VDC OFF switch connector M71.
3. Check connectors and terminals for deformation, disconnection, looseness or damage.

Is the inspection result normal?

YES >> GO TO 2.

NO >> Repair or replace as necessary.

2. CHECK VDC OFF SWITCH

Check VDC OFF switch. Refer to [BRC-105, "Component Inspection"](#).

Is the inspection result normal?

YES >> GO TO 3.

NO >> Replace VDC OFF switch.

3. CHECK VDC OFF SWITCH SIGNAL

 With CONSULT.

1. Connect ABS actuator and electric unit (control unit) connector E125 and VDC OFF switch connector M71.
2. Turn ignition switch ON.
3. In "DATA MONITOR" select "OFF SW" and check VDC OFF switch signal.

Condition	DATA MONITOR
VDC OFF switch is pressed and released	On
VDC OFF switch is pressed and released again	Off

Is the inspection result normal?

YES >> Refer to [BRC-52, "Work Flow"](#).

NO >> GO TO 4.

4. CHECK VDC OFF SWITCH CIRCUIT

1. Turn ignition switch OFF.
2. Disconnect ABS actuator and electric unit (control unit) connector E125 and VDC OFF switch connector M71.
3. Check continuity between ABS actuator and electric unit (control unit) connector E125 terminal 30 and VDC OFF switch connector M71 terminal 1.

ABS actuator and electric unit (control unit)		VDC OFF switch		Continuity
Connector	Terminal	Connector	Terminal	
E125	30	M71	1	Yes

VDC OFF SWITCH

[VDC/TCS/ABS]

< DTC/CIRCUIT DIAGNOSIS >

4. Check continuity between ABS actuator and electric unit (control unit) connector terminal E125 terminal 30 and ground.

ABS actuator and electric unit (control unit)		—	Continuity
Connector	Terminal		
E125	30	Ground	No

Is the inspection result normal?

YES >> GO TO 5.

NO >> Repair or replace malfunctioning components.

5.CHECK VDC OFF SWITCH GROUND CIRCUIT

Check continuity between VDC OFF switch connector M71 terminal 2 and ground.

VDC OFF switch		—	Continuity
Connector	Terminal		
M71	2	Ground	Yes

Is the inspection result normal?

YES >> Replace ABS actuator and electric unit (control unit). Refer to [BRC-123, "Removal and Installation"](#).

NO >> Repair or replace malfunctioning components.

Component Inspection

INFOID:000000009177325

1.CHECK VDC OFF SWITCH

- Turn ignition switch OFF.
- Disconnect VDC OFF switch connector.
- Check continuity between terminals of VDC OFF switch connector.

VDC OFF switch terminals	Condition	Continuity
1 – 2	VDC OFF switch pressed	Yes
	VDC OFF switch released	No

Is the inspection result normal?

YES >> Inspection End.

NO >> Replace VDC OFF switch.

ABS WARNING LAMP

Component Function Check

INFOID:000000009177326

1.CHECK ABS WARNING LAMP FUNCTION

Check that ABS warning lamp in combination meter turns ON for approximately 2 seconds after ignition switch is turned ON.

Is the inspection result normal?

YES >> Inspection End.

NO >> Proceed to diagnosis procedure. Refer to [BRC-106, "Diagnosis Procedure"](#).

Diagnosis Procedure

INFOID:000000009177327

1.PERFORM THE SELF-DIAGNOSIS

 With CONSULT.

Perform self-diagnostic result.

Are any DTCs detected?

YES >> Refer to [BRC-42, "DTC Index"](#).

NO >> GO TO 2.

2.CHECK COMBINATION METER

Check if indication and operation of combination meter are normal. Refer to [MWI-9, "METER SYSTEM : System Description"](#).

Is the inspection result normal?

YES >> Replace ABS actuator and electric unit (control unit). Refer to [BRC-123, "Removal and Installation"](#).

NO >> Replace combination meter. Refer to [MWI-82, "Removal and Installation"](#).

BRAKE WARNING LAMP

< DTC/CIRCUIT DIAGNOSIS >

[VDC/TCS/ABS]

BRAKE WARNING LAMP

Component Function Check

INFOID:000000009177328

1.CHECK BRAKE WARNING LAMP FUNCTION (1)

Check that brake warning lamp in combination meter turns ON for approximately 2 seconds after ignition switch is turned ON.

Is the inspection result normal?

YES >> GO TO 2.

NO >> Proceed to diagnosis procedure. Refer to [BRC-107. "Diagnosis Procedure"](#).

2.CHECK BRAKE WARNING LAMP FUNCTION (2)

Check that brake warning lamp in combination meter turns ON/OFF when parking brake is operated.

Is the inspection result normal?

YES >> Inspection End.

NO >> Check parking brake switch system. Refer to [BRC-103. "Diagnosis Procedure"](#).

Diagnosis Procedure

INFOID:000000009177329

BRC

1.PERFORM THE SELF-DIAGNOSIS

Ⓜ With CONSULT.

Perform self-diagnostic result.

Are any DTCs detected?

YES >> Refer to [BRC-42. "DTC Index"](#).

NO >> GO TO 2.

2.CHECK COMBINATION METER

Check if indication and operation of combination meter are normal. Refer to [MWI-9. "METER SYSTEM : System Description"](#).

Is the inspection result normal?

YES >> Replace ABS actuator and electric unit (control unit). Refer to [BRC-123. "Removal and Installation"](#).

NO >> Replace combination meter. Refer to [MWI-82. "Removal and Installation"](#).

VDC OFF INDICATOR LAMP

Component Function Check

INFOID:000000009177330

1. CHECK VDC OFF INDICATOR LAMP FUNCTION (1)

Check that VDC OFF indicator lamp in combination meter turns ON for approximately 2 seconds after ignition switch is turned ON.

Is the inspection result normal?

YES >> GO TO 2.

NO >> Proceed to diagnosis procedure. Refer to [BRC-108, "Diagnosis Procedure"](#).

2. CHECK VDC OFF INDICATOR LAMP FUNCTION (2)

Check that VDC OFF indicator lamp in combination meter turns ON/OFF when VDC OFF switch is operated.

Is the inspection result normal?

YES >> Inspection End.

NO >> Check VDC OFF switch. Refer to [BRC-104, "Diagnosis Procedure"](#).

Diagnosis Procedure

INFOID:000000009177331

1. PERFORM THE SELF-DIAGNOSIS

Ⓟ With CONSULT.

Perform self diagnostic result.

Are any DTCs detected?

YES >> Refer to [BRC-42, "DTC Index"](#).

NO >> GO TO 2.

2. CHECK COMBINATION METER

Check if indication and operation of combination meter are normal. Refer to [MWI-9, "METER SYSTEM : System Description"](#).

Is the inspection result normal?

YES >> Replace ABS actuator and electric unit (control unit). Refer to [BRC-123, "Removal and Installation"](#).

NO >> Replace combination meter. Refer to [MWI-82, "Removal and Installation"](#).

SLIP INDICATOR LAMP

< DTC/CIRCUIT DIAGNOSIS >

[VDC/TCS/ABS]

SLIP INDICATOR LAMP

Component Function Check

INFOID:000000009177332

1.CHECK SLIP INDICATOR LAMP FUNCTION

Check that slip indicator lamp in combination meter turns ON for approximately 2 seconds after ignition switch is turned ON.

Is the inspection result normal?

YES >> Inspection End.

NO >> Proceed to diagnosis procedure. Refer to [BRC-109, "Diagnosis Procedure"](#).

Diagnosis Procedure

INFOID:000000009177333

1.PERFORM THE SELF-DIAGNOSIS

With CONSULT.

Perform self diagnostic result.

Are any DTCs detected?

YES >> Refer to [BRC-42, "DTC Index"](#).

NO >> GO TO 2.

2.CHECK COMBINATION METER

Check if indication and operation of combination meter are normal. Refer to [MWI-9, "METER SYSTEM : System Description"](#).

Is the inspection result normal?

YES >> Replace ABS actuator and electric unit (control unit). Refer to [BRC-123, "Removal and Installation"](#).

NO >> Replace combination meter. Refer to [MWI-82, "Removal and Installation"](#).

A
B
C
D
E
BRC
G
H
I
J
K
L
M
N
O
P

SYMPTOM DIAGNOSIS

VDC/TCS/ABS

Symptom Table

INFOID:000000009177334

If ABS warning lamp, VDC OFF indicator lamp and SLIP indicator lamp turn ON, perform self-diagnosis.

Symptom	Check item	Reference
Excessive ABS function operation frequency	Brake force distribution	BRC-111. "Diagnosis Procedure"
	Looseness of front and rear axle	
	Wheel sensor and rotor system	
Unexpected pedal reaction	Brake pedal stroke	BRC-112. "Diagnosis Procedure"
	Make sure the braking force is sufficient when the ABS is not operating.	
The braking distance is long	Check stopping distance when the ABS is not operating.	BRC-113. "Diagnosis Procedure"
ABS function does not operate (Note 1)	ABS actuator and electric unit (control unit)	BRC-114. "Diagnosis Procedure"
Pedal vibration or ABS operation sound occurs (Note 2)	Brake pedal	BRC-115. "Diagnosis Procedure"
	ABS actuator and electric unit (control unit)	
Vehicle jerks during VDC/TCS/ABS control	ABS actuator and electric unit (control unit)	BRC-116. "Diagnosis Procedure"
	TCM	
	ECM	

NOTE:

- 1: The ABS does not operate when the speed is 10 km/h (6 MPH) or less.
- 2: Under the following conditions, ABS is activated and vibration is felt when brake pedal is lightly depressed (just place a foot on it). However, this is normal.
 - When shifting gears
 - When driving on slippery road
 - During cornering at high speed
 - When passing over bumps or grooves [approximately 50 mm (1.97 in) or more]
 - When pulling away just after starting engine [at approximately 10 km/h (6 MPH) or higher]

EXCESSIVE OPERATION FREQUENCY

< SYMPTOM DIAGNOSIS >

[VDC/TCS/ABS]

EXCESSIVE OPERATION FREQUENCY

Description

INFOID:000000009177335

VDC function, TCS function, ABS function, EBD function or hill start assist function operates in excessive operation frequency.

Diagnosis Procedure

INFOID:000000009177336

1. CHECK BRAKING FORCE

Check brake force using a brake tester.

Is the inspection result normal?

YES >> GO TO 2.

NO >> Check brake system.

2. CHECK FRONT AND REAR AXLE

Check that there is no excessive looseness in front and rear axle.

- Front axle: Refer to [FAX-6, "Inspection"](#).
- Rear axle: Refer to [RAX-5, "Inspection"](#).

Is the inspection result normal?

YES >> GO TO 3.

NO >> Repair or replace malfunctioning components.

3. CHECK WHEEL SENSOR

Check wheel sensor.

- Check installation and damage of wheel sensor.
- Check connection of wheel sensor harness connector.
- Check terminal of wheel sensor harness connector.

Is the inspection result normal?

YES >> GO TO 4.

NO >> Repair installation or replace wheel sensor.

- Front wheel sensor: Refer to [BRC-118, "Removal and Installation - Front Wheel Sensor"](#).
- Rear wheel sensor: Refer to [BRC-120, "Removal and Installation - Rear Wheel Sensor"](#).

4. CHECK SENSOR ROTOR

Check that there is no looseness, damage or foreign material on sensor rotor.

Is the inspection result normal?

YES >> GO TO 5.

NO >> Repair installation or replace sensor rotor.

- Front sensor rotor: Refer to [BRC-122, "Removal and Installation - Front Sensor Rotor"](#).
- Rear sensor rotor: Refer to [BRC-122, "Removal and Installation - Rear Sensor Rotor"](#).

5. CHECK WARNING LAMP TURNS OFF

Check that ABS warning lamp, brake warning lamp and VDC warning lamp turn OFF approx. 1 second after key switch is turned ON and stay in OFF status during driving.

CAUTION:

Brake warning lamp turns ON when parking brake is operated (parking brake switch is ON) or brake fluid is less than the specified level (brake fluid level switch is ON).

Is the inspection result normal?

YES >> Inspection End.

NO >> Perform self-diagnosis result. Refer to [BRC-32, "CONSULT Function"](#).

UNEXPECTED BRAKE PEDAL REACTION

< SYMPTOM DIAGNOSIS >

[VDC/TCS/ABS]

UNEXPECTED BRAKE PEDAL REACTION

Description

INFOID:000000009177337

A malfunction of brake pedal feel (height or others) is detected when brake pedal is depressed.

Diagnosis Procedure

INFOID:000000009177338

1.CHECK FRONT AND REAR AXLE

Check that there is no excessive looseness in front and rear axle.

- Front axle: Refer to [FAX-6. "Inspection"](#).
- Rear axle: Refer to [RAX-5. "Inspection"](#).

Is the inspection result normal?

- YES >> GO TO 2.
- NO >> Repair or replace malfunctioning components.

2.CHECK DISC ROTOR

Check disc rotor runout.

- Front: Refer to [BR-11. "DISC ROTOR : Inspection"](#).
- Rear: Refer to [BR-13. "DISC ROTOR : Inspection"](#).

Is the inspection result normal?

- YES >> GO TO 3.
- NO >> Refinish the disc rotor.

3.CHECK BRAKE FLUID LEAKAGE

Check fluid leakage. Refer to [BR-8. "Inspection"](#).

Is the inspection result normal?

- YES >> GO TO 4.
- NO >> Repair or replace malfunctioning components.

4.CHECK BRAKE PEDAL

Check brake pedal. Refer to [BR-7. "Inspection"](#).

Is the inspection result normal?

- YES >> GO TO 5.
- NO >> Adjust brake pedal. Refer to [BR-15. "Adjustment"](#).

5.CHECK BRAKING FORCE

Check brake force using a brake tester.

Is the inspection result normal?

- YES >> GO TO 6.
- NO >> Check brake system.

6.CHECK BRAKE PERFORMANCE

Disconnect ABS actuator and electric unit (control unit) connector so that ABS does not operate. Check that brake force is normal in this condition. Connect harness connectors after checking.

Is the inspection result normal?

- YES >> Inspection End.
- NO >> Check brake system.

THE BRAKING DISTANCE IS LONG

< SYMPTOM DIAGNOSIS >

[VDC/TCS/ABS]

THE BRAKING DISTANCE IS LONG

Description

INFOID:000000009177339

Brake stopping distance is long when ABS function is operated.

Diagnosis Procedure

INFOID:000000009177340

CAUTION:

Brake stopping distance on slippery roads like a rough road, gravel road or snowy road may become longer when ABS is operated than when ABS is not operated.

1.CHECK BRAKING FORCE

Check brake force using a brake tester.

Is the inspection result normal?

YES >> GO TO 2.

NO >> Check brake system.

2.CHECK BRAKE PERFORMANCE

Disconnect ABS actuator and electric unit (control unit) connector so that ABS does not operate. Check brake stopping distance in this condition. Connect harness connectors after checking.

Is the inspection result normal?

YES >> Inspection End.

NO >> Check brake system.

A
B
C
D
E
BRC
G
H
I
J
K
L
M
N
O
P

ABS FUNCTION DOES NOT OPERATE

< SYMPTOM DIAGNOSIS >

[VDC/TCS/ABS]

ABS FUNCTION DOES NOT OPERATE

Description

INFOID:000000009177341

VDC function, TCS function, ABS function, EBD function or hill start assist function does not operate.

Diagnosis Procedure

INFOID:000000009177342

CAUTION:

- VDC function, TCS function, ABS function, EBD function and hill start assist function never operate when the vehicle speed is 10 km/h (6.2 MPH) or less. However, hill start assist function operates when the vehicle speed is 0 km/h (0 MPH) (the vehicle is in stop status).
- VDC function and TCS function never operate when VDC OFF switch is operated (when VDC OFF indicator lamp turns ON).

1. CHECK ABS WARNING LAMP

Check that ABS warning lamp, brake warning lamp and VDC warning lamp turn ON and turn OFF approx. 1 second after key switch is turned ON. Check that ABS warning lamp, brake warning lamp and VDC warning lamp and stay in OFF status during driving.

CAUTION:

Brake warning lamp turns ON when parking brake is operated (parking brake switch is ON) or brake fluid is less than the specified level (brake fluid level switch is ON).

Is the inspection result normal?

YES >> Inspection End.

NO >> Perform self-diagnosis result"". Refer to [BRC-32, "CONSULT Function"](#).

BRAKE PEDAL VIBRATION OR OPERATION SOUND OCCURS

< SYMPTOM DIAGNOSIS >

[VDC/TCS/ABS]

BRAKE PEDAL VIBRATION OR OPERATION SOUND OCCURS

Description

INFOID:000000009177343

- Brake pedal vibrates and motor sound from ABS actuator and electric unit (control unit) occurs when the engine starts.
- Brake pedal vibrates during braking.

CAUTION:

Vibration may be felt during brake pedal is lightly depressed (just placing a foot on it) in the following conditions. This is normal.

- When shifting gears
- When driving on slippery road
- During cornering at high speed
- When passing over bumps or grooves [Approx. 50 mm (1.97 in) or more]
- When pulling away just after starting engine [at approx. 10 km/h (6.2 MPH) or higher]

Diagnosis Procedure

INFOID:000000009177344

1. SYMPTOM CHECK 1

Check that there are pedal vibrations when the engine is started.

Do vibrations occur?

YES >> GO TO 2.

NO >> Check brake pedal. Refer to [BR-7. "Inspection"](#).

2. SYMPTOM CHECK 2

Check that motor sound from ABS actuator occurs when the engine starts.

Does the operation sound occur?

YES >> GO TO 3.

NO >> Perform self-diagnosis result. Refer to [BRC-32. "CONSULT Function"](#).

3. SYMPTOM CHECK 3

Check symptoms when electrical component (head lamps, etc.) switches are operated.

Does the symptom occur?

YES >> Check that radio (including wiring), antenna and antenna lead-in wires are not located near ABS actuator and electric unit (control unit). Move them if they are located near ABS actuator and electric unit (control unit).

NO >> Inspection End.

A
B
C
D
E
G
H
I
J
K
L
M
N
O
P

BRC

VEHICLE JERKS DURING VDC/TCS/ABS CONTROL

< SYMPTOM DIAGNOSIS >

[VDC/TCS/ABS]

VEHICLE JERKS DURING VDC/TCS/ABS CONTROL

Description

INFOID:000000009177345

The vehicle jerks when VDC function, TCS function, ABS function, EBD function or hill start assist function operates.

Diagnosis Procedure

INFOID:000000009177346

1. CHECK SYMPTOM

Check that the vehicle jerks when VDC function, TCS function, ABS function, EBD function or hill start assist function operates.

Is the inspection result normal?

- YES >> Inspection End.
- NO >> GO TO 2.

2. PERFORM THE SELF-DIAGNOSIS

Ⓜ With CONSULT

Perform self-diagnosis result. Refer to [BRC-32, "CONSULT Function"](#).

Is any DTC detected?

- YES >> Check the DTC. Refer to [BRC-42, "DTC Index"](#).
- NO >> GO TO 3.

3. CHECK CONNECTOR

Ⓜ With CONSULT

1. Turn the ignition switch OFF.
2. Disconnect ABS actuator and electric unit (control unit) harness connector.
3. Check connector terminal for deformation, disconnection and looseness.
4. Connect harness connector and perform self-diagnosis result. Refer to [BRC-32, "CONSULT Function"](#).

Is the inspection result normal?

- YES >> GO TO 4.
- NO >> Repair or replace connector terminal.

4. CHECK ECM AND TCM SELF-DIAGNOSIS RESULTS

Ⓜ With CONSULT

Perform self-diagnosis result for "ENGINE" and "TRANSMISSION".

Is any DTC detected?

- YES >> Check the DTC.
- NO >> Replace ABS actuator and electric unit (control unit). Refer to [BRC-123, "Removal and Installation"](#).

NORMAL OPERATING CONDITION

< SYMPTOM DIAGNOSIS >

[VDC/TCS/ABS]

NORMAL OPERATING CONDITION

Description

INFOID:000000009177347

Symptom	Result
Brake pedal slightly vibrates and operation sound (motor sound and sound from suspension) occurs when VDC function, TCS function, ABS function, EBD function or hill start assist function operates.	This is not a malfunction, because it is caused by VDC function, TCS function, ABS function, EBD function and hill start assist function that are normally operated.
Brake stopping distance may become longer than models without ABS function depending on the road conditions, when ABS function is operated on slippery road like rough road, gravel road or snowy road.	
Brake pedal vibrates and operation sound occurs during sudden acceleration and cornering, when VDC function or TCS function is operated.	
Brake pedal vibrates and motor sound from the engine room occurs when the engine starts or the vehicle starts just after starting the engine.	This is not a malfunction because it is caused by operation check of ABS actuator and electric unit (control unit).
Acceleration may be felt insufficient depending on the road conditions.	This is not a malfunction because it is caused by TCS function that puts the highest priority to obtain the optimum traction (stability).
TCS function may operate momentarily while driving on a road where friction coefficient varies or when downshifting or fully depressing accelerator pedal.	
ABS warning lamp and VDC warning lamp may turn ON when the vehicle is on a rotating turntable or is given a strong shaking or large vibrations on a ship while the engine is running.	In this case, restart the engine on a normal road. If the normal condition is restored, there is no malfunction. In that case, erase "ABS" self-diagnosis result memory with CONSULT.
VDC warning lamp may turn ON and VDC function and TCS function may not normally operate, when driving on a special road the is extremely slanted (bank in a circuit course).	
A malfunction in yaw rate/side/decel G sensor system may be detected when the vehicle sharply turns during a spin turn, acceleration turn or drift driving while VDC function and TCS function are OFF (VDC OFF switch is pressed and VDC OFF indicator lamp is in ON status).	
The vehicle speed does not increase when the accelerator pedal is depressed while the vehicle is on a 2-wheel chassis dynamometer for speedometer check.	This is normal. (When checking the vehicle on a chassis dynamometer, operate VDC OFF switch so that TCS function is OFF.)

A
B
C
D
E
BRC
G
H
I
J
K
L
M
N
O
P

WHEEL SENSOR

< UNIT REMOVAL AND INSTALLATION >

[VDC/TCS/ABS]

UNIT REMOVAL AND INSTALLATION

WHEEL SENSOR

Exploded View - Front Wheel Sensor

INFOID:000000009177348

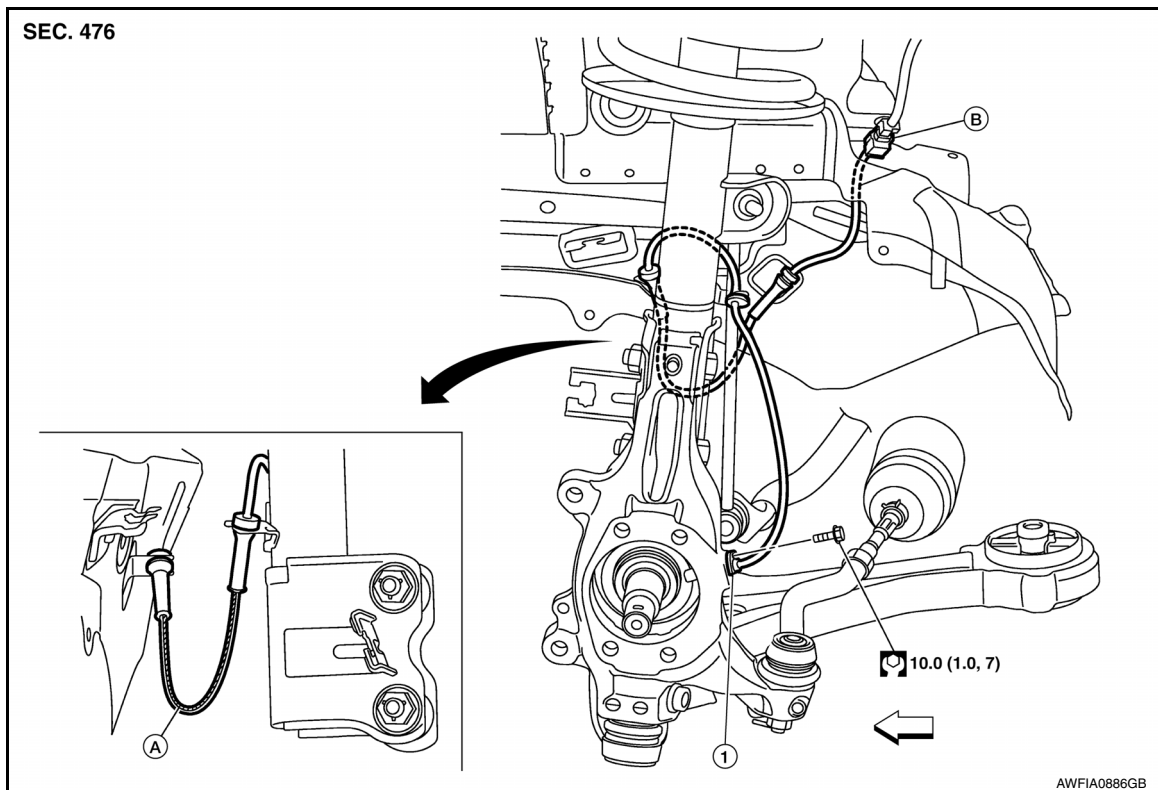

1. Front wheel sensor

A. Color line (slant line)

B. Front wheel sensor connector

⇐ Front

Removal and Installation - Front Wheel Sensor

INFOID:000000009177349

CAUTION:

- Be careful not to damage front wheel sensor edge and sensor rotor teeth.
- When removing the front wheel hub and bearing, first remove the front wheel sensor from the steering knuckle. Failure to do so may result in damage to the front wheel sensor wires making the front wheel sensor inoperative.
- Pull out the front wheel sensor, being careful to turn it as little as possible. Do not pull on the front wheel sensor harness.
- Before installation, check if foreign objects such as iron fragments are adhered to the pick-up part of the front wheel sensor or to the inside of the hole in the steering knuckle for the front wheel sensor, or if a foreign object is caught in the surface of the mating surface for the sensor rotor. Fix as necessary and then install the front wheel sensor.

REMOVAL

1. Remove the front wheel and tire using power tool. Refer to [WT-58, "Adjustment"](#).
2. Partially remove the fender protector to gain access to the wheel sensor harness connector.
3. Disconnect the harness connector from the front wheel sensor.
4. Remove the front wheel sensor bolt.
5. Remove the front wheel sensor from the strut bracket and body brackets.
6. Remove the front wheel sensor from the steering knuckle.

INSTALLATION

WHEEL SENSOR

< UNIT REMOVAL AND INSTALLATION >

[VDC/TCS/ABS]

Installation is in the reverse order of removal.

CAUTION:

- When installing, make sure there is no foreign material such as iron chips on and in the hole in the steering knuckle for the front wheel sensor. Make sure no foreign material has been caught in the sensor rotor. Remove any foreign material and clean the mount.
- Do not twist front wheel sensor harness when installing front wheel sensor. Check that grommet (2) is fully inserted to bracket (1). Check that front wheel sensor harness is not twisted after installation.

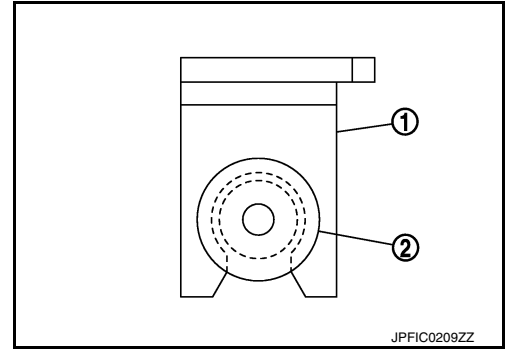

Exploded View - Rear Wheel Sensor

INFOID:000000009177350

BRC

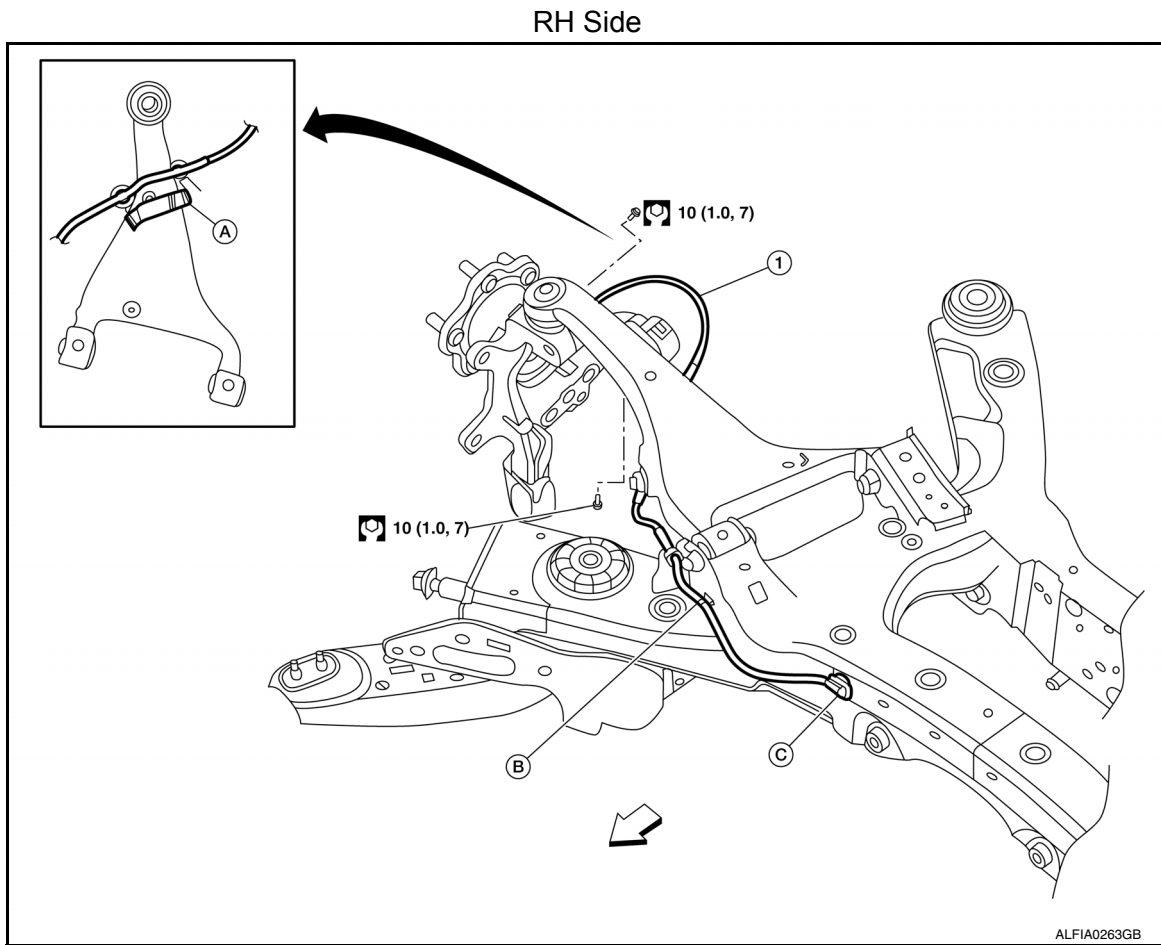

- 1. Rear wheel sensor
- A. Rear wheel sensor bracket
- B. Clip
- C. Rear wheel sensor connector
- ← Front

A
B
C
D
E
G
H
I
J
K
L
M
N
O
P

WHEEL SENSOR

< UNIT REMOVAL AND INSTALLATION >

[VDC/TCS/ABS]

LH Side

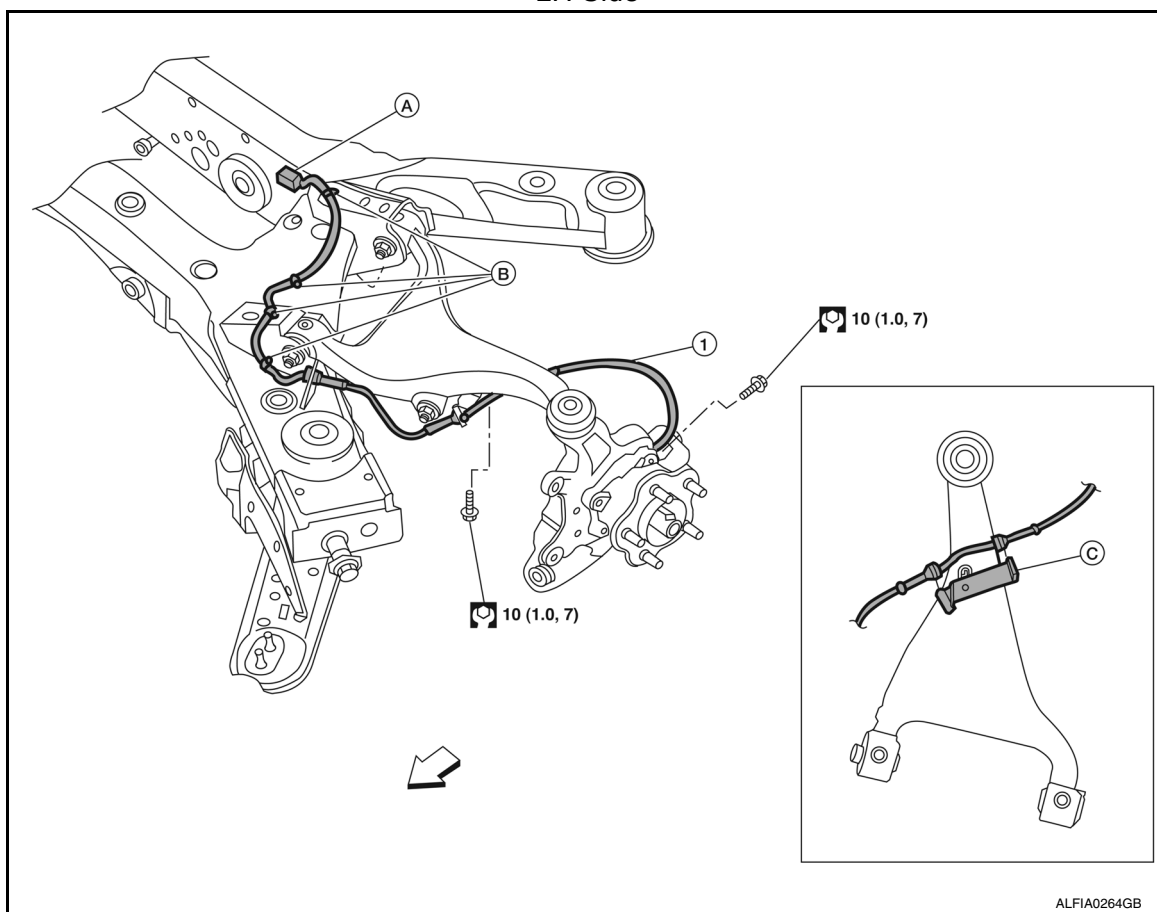

- | | | |
|------------------------------|--------------------------------|---------|
| 1. Rear wheel sensor | A. Rear wheel sensor connector | B. Clip |
| C. Rear wheel sensor bracket | ↔ Front | |

Removal and Installation - Rear Wheel Sensor

INFOID:000000009177351

CAUTION:

- Be careful not to damage rear wheel sensor edge and sensor rotor teeth.
- When removing the rear wheel hub and bearing, first remove the rear wheel sensor from the rear knuckle. Failure to do so may result in damage to the rear wheel sensor wires making the rear wheel sensor inoperative.
- Pull out the rear wheel sensor, being careful to turn it as little as possible. Do not pull on the rear wheel sensor harness.
- Before installation, check if foreign objects such as iron fragments are adhered to the pick-up part of the rear wheel sensor or to the inside of the hole in the rear knuckle for the rear wheel sensor, or if a foreign object is caught in the surface of the mating surface for the sensor rotor. Fix as necessary and then install the rear wheel sensor.

REMOVAL

1. Remove the rear wheel and tire using power tool. Refer to [WT-58, "Adjustment"](#).
2. Remove the rear wheel sensor bolt.
3. Disconnect the harness connector from the rear wheel sensor.
4. Remove the rear wheel sensor from the sensor brackets.
5. Remove the rear wheel sensor from the rear knuckle.

INSTALLATION

Installation is in the reverse order of removal.

CAUTION:

WHEEL SENSOR

< UNIT REMOVAL AND INSTALLATION >

[VDC/TCS/ABS]

- When installing, make sure there is no foreign material such as iron chips on and in the hole in the rear knuckle for the rear wheel sensor. Make sure no foreign material has been caught in the sensor rotor. Remove any foreign material and clean the mount.
- Do not twist rear wheel sensor harness when installing rear wheel sensor. Check that grommet (2) is fully inserted to bracket (1). Check that rear wheel sensor harness is not twisted after installation.

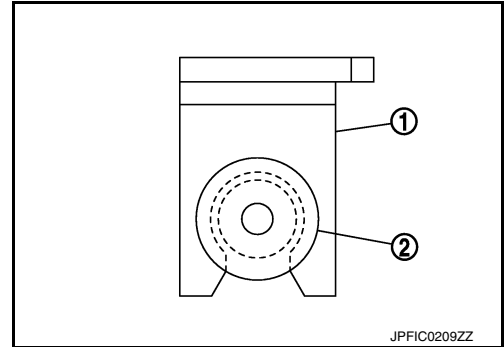

A
B
C
D
E

BRC

G
H
I
J
K
L
M
N
O
P

SENSOR ROTOR

< UNIT REMOVAL AND INSTALLATION >

[VDC/TCS/ABS]

SENSOR ROTOR

Removal and Installation - Front Sensor Rotor

INFOID:000000009177352

The front wheel sensor rotor is an integral part of the wheel hub and bearing and cannot be disassembled. Refer to [FAX-8, "Removal and Installation"](#).

Removal and Installation - Rear Sensor Rotor

INFOID:000000009177353

The rear wheel sensor rotor is an integral part of the wheel hub and bearing and cannot be disassembled. Refer to [RAX-7, "Removal and Installation"](#).

ABS ACTUATOR AND ELECTRIC UNIT (CONTROL UNIT)

< UNIT REMOVAL AND INSTALLATION >

[VDC/TCS/ABS]

ABS ACTUATOR AND ELECTRIC UNIT (CONTROL UNIT)

Exploded View

INFOID:000000009177354

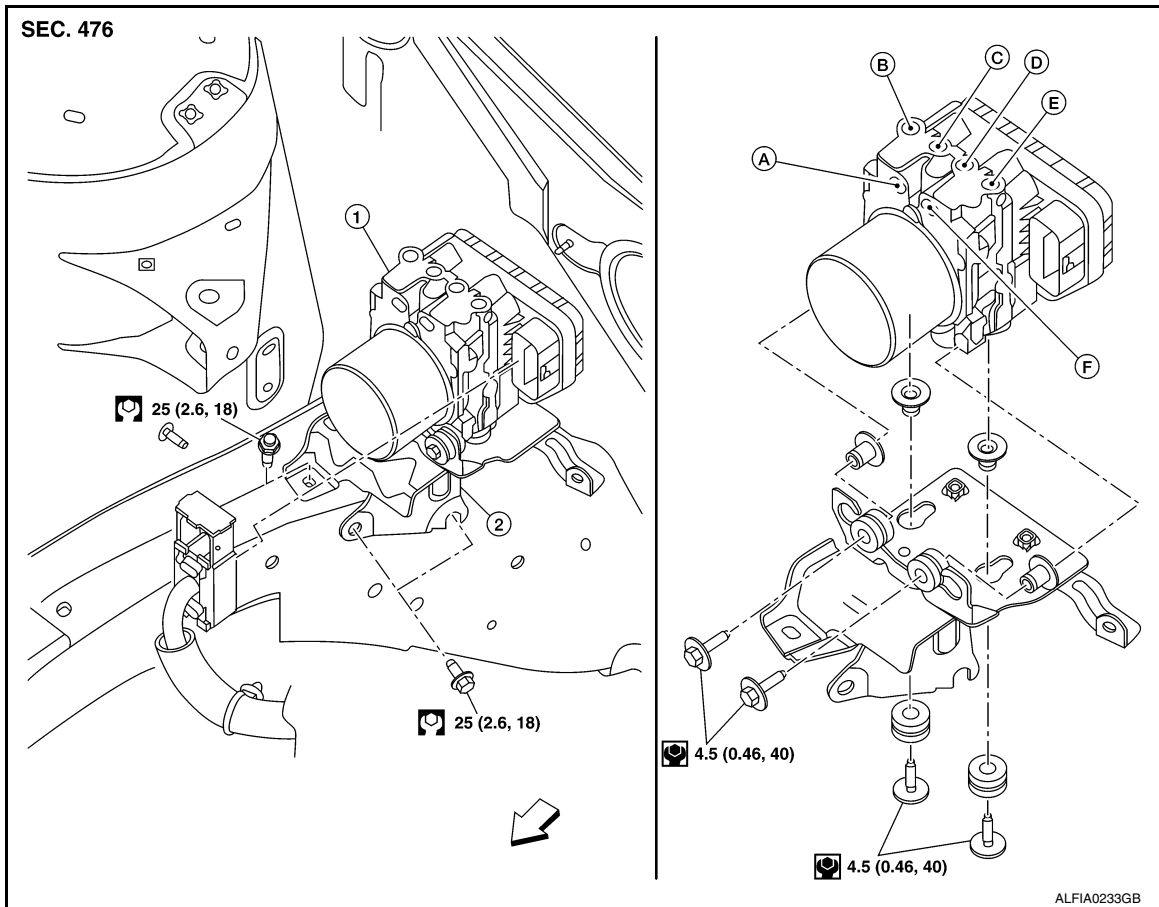

- | | | |
|--|--------------------------------------|--|
| 1. ABS actuator and electric unit (control unit) | 2. Bracket | A. From master cylinder secondary side |
| B. To front RH brake caliper | C. To rear LH brake caliper | D. To rear RH brake caliper |
| E. To front LH brake caliper | F. From master cylinder primary side | ⇐ Front |

Removal and Installation

INFOID:000000009177355

REMOVAL

CAUTION:

- To remove brake tube, use a flare nut wrench to prevent flare nuts and brake tube from being damaged.
- Do not remove actuator by holding harness.

NOTE:

When removing components such as hoses, tubes/lines, etc., cap or plug openings to prevent fluid from spilling.

1. Disconnect negative battery terminal. Refer to [PG-90, "Exploded View"](#).
2. Remove cowl top. Refer to [EXT-25, "Removal and Installation"](#).
3. Disconnect ABS actuator and electric unit (control unit) harness connector.
4. Separate brake tubes from ABS actuator and electric unit (control unit). Refer to [BR-22, "FRONT : Exploded View"](#).
5. Remove ABS actuator and electric unit (control unit) bracket bolts.
6. Remove ABS actuator and electric unit (control unit) from vehicle.

INSTALLATION

A
B
C
D
E
BRC
G
H
I
J
K
L
M
N
O
P

ABS ACTUATOR AND ELECTRIC UNIT (CONTROL UNIT)

< UNIT REMOVAL AND INSTALLATION >

[VDC/TCS/ABS]

Installation is in the reverse order of removal.

- After work is completed, bleed air from brake tube. Refer to [BR-16, "Bleeding Brake System"](#).
- Adjust the neutral position of steering angle sensor. Refer to [BRC-55, "Work Procedure"](#).
- Perform calibration of the yaw rate/side/decel G sensor: Refer to [BRC-57, "Work Procedure"](#).

CAUTION:

- **To install, use flare nut crowfoot and torque wrench.**
- **Do not apply excessive impact to ABS actuator and electric unit (control unit), such as dropping it.**
- **Do not install actuator by holding harness.**
- **After installing harness connector in the ABS actuator and electric unit (control unit), make sure connector is securely locked.**

YAW RATE/SIDE/DECEL G SENSOR

< UNIT REMOVAL AND INSTALLATION >

[VDC/TCS/ABS]

YAW RATE/SIDE/DECEL G SENSOR

Exploded View

INFOID:000000009177356

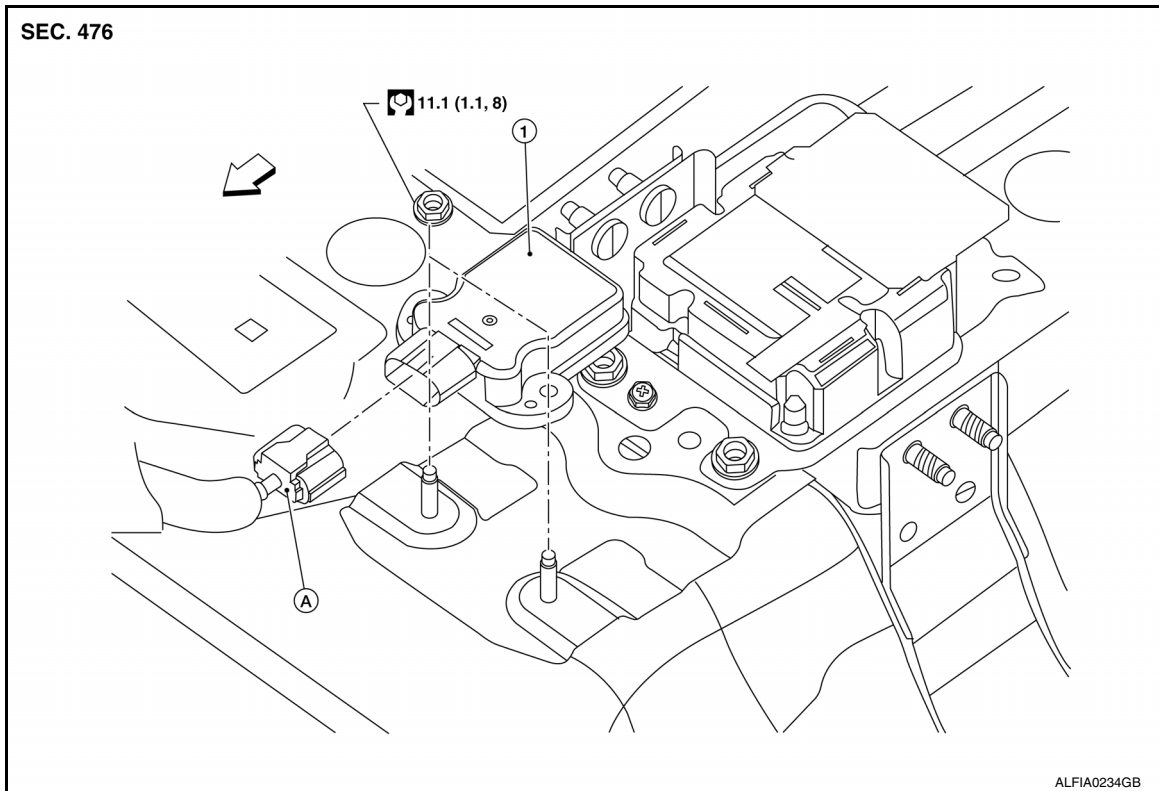

1. Yaw rate/side/decel G sensor

A. Harness connector

← Front

Removal and Installation

INFOID:000000009177357

REMOVAL

1. Remove the side stay cover from the center console assembly. Refer to [IP-27, "Exploded View"](#).
2. Disconnect the harness connector from the yaw rate/side/decel G sensor.
3. Remove the yaw rate/side/decel G sensor nuts.
4. Remove yaw rate/side/decel G sensor.

INSTALLATION

Installation is in the reverse order of removal.

- Perform calibration of the yaw rate/side/decel G sensor. Refer to [BRC-57, "Work Procedure"](#).

CAUTION:

- Do not use power tools on the yaw rate/side/decel G sensor because it is sensitive to the impact.
- Replace the yaw rate/side/decel G sensor if it has been dropped or sustained impact.

STEERING ANGLE SENSOR

< UNIT REMOVAL AND INSTALLATION >

[VDC/TCS/ABS]

STEERING ANGLE SENSOR

Removal and Installation

INFOID:000000009177359

To remove and install the steering angle sensor, remove and install spiral cable. Refer to [SR-15. "Removal and Installation"](#).