

SECTION **INL**

INTERIOR LIGHTING SYSTEM

A
B
C
D
E
F
G
H
I
J
K
INL
M
N
O
P

CONTENTS

PRECAUTION	3	BATTERY SAVER	10
PRECAUTIONS	3	BATTERY SAVER : CONSULT Function (BCM -	
Precaution for Supplemental Restraint System		BATTERY SAVER)	10
(SRS) "AIR BAG" and "SEAT BELT PRE-TENSIONER"	3	ECU DIAGNOSIS INFORMATION	11
Precaution for Work	3	BCM	11
PREPARATION	4	List of ECU Reference	11
PREPARATION	4	WIRING DIAGRAM	12
Special Service Tool	4	INTERIOR ROOM LAMP CONTROL SYSTEM	
SYSTEM DESCRIPTION	5	12
COMPONENT PARTS	5	Wiring Diagram	12
Component Parts Location	5	ILLUMINATION	26
Component Description	5	Wiring Diagram	26
SYSTEM	6	BASIC INSPECTION	44
INTERIOR ROOM LAMP CONTROL SYSTEM	6	DIAGNOSIS AND REPAIR WORKFLOW	44
INTERIOR ROOM LAMP CONTROL SYSTEM :		Work Flow	44
System Diagram	6	DTC/CIRCUIT DIAGNOSIS	47
INTERIOR ROOM LAMP CONTROL SYSTEM :		POWER SUPPLY AND GROUND CIRCUIT	47
System Description	6	BCM	47
ILLUMINATION CONTROL SYSTEM	7	BCM : Diagnosis Procedure	47
ILLUMINATION CONTROL SYSTEM : System		IPDM E/R (INTELLIGENT POWER DISTRIBUTION	
Diagram	7	MODULE ENGINE ROOM)	47
ILLUMINATION CONTROL SYSTEM : System		IPDM E/R (INTELLIGENT POWER DISTRIBUTION	
Description	7	MODULE ENGINE ROOM) : Diagnosis Procedure	47
DIAGNOSIS SYSTEM (BCM)	8	BATTERY SAVER OUTPUT/POWER SUPPLY	
COMMON ITEM	8	CIRCUIT	49
COMMON ITEM : CONSULT Function (BCM -		Description	49
COMMON ITEM)	8	Component Function Check	49
INT LAMP	9	Diagnosis Procedure	49
INT LAMP : CONSULT Function (BCM - INT			
LAMP)	9		

INTERIOR ROOM LAMP CONTROL CIRCUIT	Bulb Replacement	61
Description	FOOT LAMP	62
Component Function Check	DRIVER SIDE	62
Diagnosis Procedure	DRIVER SIDE : Exploded View	62
STEP LAMP CIRCUIT	DRIVER SIDE : Removal and Installation	62
Description	DRIVER SIDE : Bulb Replacement	62
Component Function Check	PASSENGER SIDE	62
Diagnosis Procedure	PASSENGER SIDE : Exploded View	63
PUSH-BUTTON IGNITION SWITCH ILLUMINATION CIRCUIT	PASSENGER SIDE : Bulb Replacement	63
Description	FRONT STEP LAMP	64
Component Function Check	Exploded View	64
Diagnosis Procedure	Removal and Installation	64
SYMPTOM DIAGNOSIS	Bulb or Lens Replacement	64
INTERIOR LIGHTING SYSTEM SYMPTOMS ...	PERSONAL LAMP	65
Symptom Table	Removal and Installation	65
REMOVAL AND INSTALLATION	Bulb or Lens Replacement	65
FRONT ROOM/MAP LAMP ASSEMBLY	CARGO LAMP	66
Exploded View	Exploded View	66
Removal and Installation	Removal and Installation	66
Bulb or Lens Replacement	Bulb or Lens Replacement	66
VANITY LAMP	ILLUMINATION CONTROL SWITCH	67
Exploded View	Removal and Installation	67
Removal and Installation	SERVICE DATA AND SPECIFICATIONS (SDS)	68
Bulb or Lens Replacement	SERVICE DATA AND SPECIFICATIONS (SDS)	68
GLOVE BOX LAMP	Bulb Specifications	68
Exploded View		

PRECAUTIONS

< PRECAUTION >

PRECAUTION

PRECAUTIONS

Precaution for Supplemental Restraint System (SRS) "AIR BAG" and "SEAT BELT PRE-TENSIONER"

INFOID:000000009175423

The Supplemental Restraint System such as "AIR BAG" and "SEAT BELT PRE-TENSIONER", used along with a front seat belt, helps to reduce the risk or severity of injury to the driver and front passenger for certain types of collision. Information necessary to service the system safely is included in the SR and SB section of this Service Manual.

WARNING:

- To avoid rendering the SRS inoperative, which could increase the risk of personal injury or death in the event of a collision which would result in air bag inflation, all maintenance must be performed by an authorized NISSAN/INFINITI dealer.
- Improper maintenance, including incorrect removal and installation of the SRS, can lead to personal injury caused by unintentional activation of the system. For removal of Spiral Cable and Air Bag Module, see the SR section.
- Do not use electrical test equipment on any circuit related to the SRS unless instructed to in this Service Manual. SRS wiring harnesses can be identified by yellow and/or orange harnesses or harness connectors.

PRECAUTIONS WHEN USING POWER TOOLS (AIR OR ELECTRIC) AND HAMMERS

WARNING:

- When working near the Airbag Diagnosis Sensor Unit or other Airbag System sensors with the Ignition ON or engine running, DO NOT use air or electric power tools or strike near the sensor(s) with a hammer. Heavy vibration could activate the sensor(s) and deploy the air bag(s), possibly causing serious injury.
- When using air or electric power tools or hammers, always switch the Ignition OFF, disconnect the battery and wait at least three minutes before performing any service.

Precaution for Work

INFOID:000000009175424

- When removing or disassembling each component, be careful not to damage or deform it. If a component may be subject to interference, be sure to protect it with a shop cloth.
- When removing (disengaging) components with a screwdriver or similar tool, be sure to wrap the component with a shop cloth or vinyl tape to protect it.
- Protect the removed parts with a shop cloth and prevent them from being dropped.
- Replace a deformed or damaged clip.
- If a part is specified as a non-reusable part, always replace it with a new one.
- Be sure to tighten bolts and nuts securely to the specified torque.
- After installation is complete, be sure to check that each part works properly.
- Follow the steps below to clean components:
 - Water soluble dirt:
 - Dip a soft cloth into lukewarm water, wring the water out of the cloth and wipe the dirty area.
 - Then rub with a soft, dry cloth.
 - Oily dirt:
 - Dip a soft cloth into lukewarm water with mild detergent (concentration: within 2 to 3%) and wipe the dirty area.
 - Then dip a cloth into fresh water, wring the water out of the cloth and wipe the detergent off.
 - Then rub with a soft, dry cloth.
 - Do not use organic solvent such as thinner, benzene, alcohol or gasoline.
 - For genuine leather seats, use a genuine leather seat cleaner.

PREPARATION

< PREPARATION >

PREPARATION

PREPARATION

Special Service Tool

INFOID:000000009175425

The actual shapes of Kent-Moore tools may differ from those of special service tools illustrated here.

Tool number (Kent-Moore No.) Tool name	Description
— (J-46534) Trim Tool Set	Removing trim components

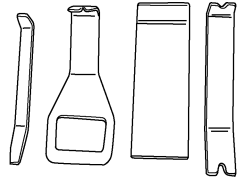

AWJIA0483ZZ

COMPONENT PARTS

< SYSTEM DESCRIPTION >

SYSTEM DESCRIPTION

COMPONENT PARTS

Component Parts Location

INFOID:000000009175426

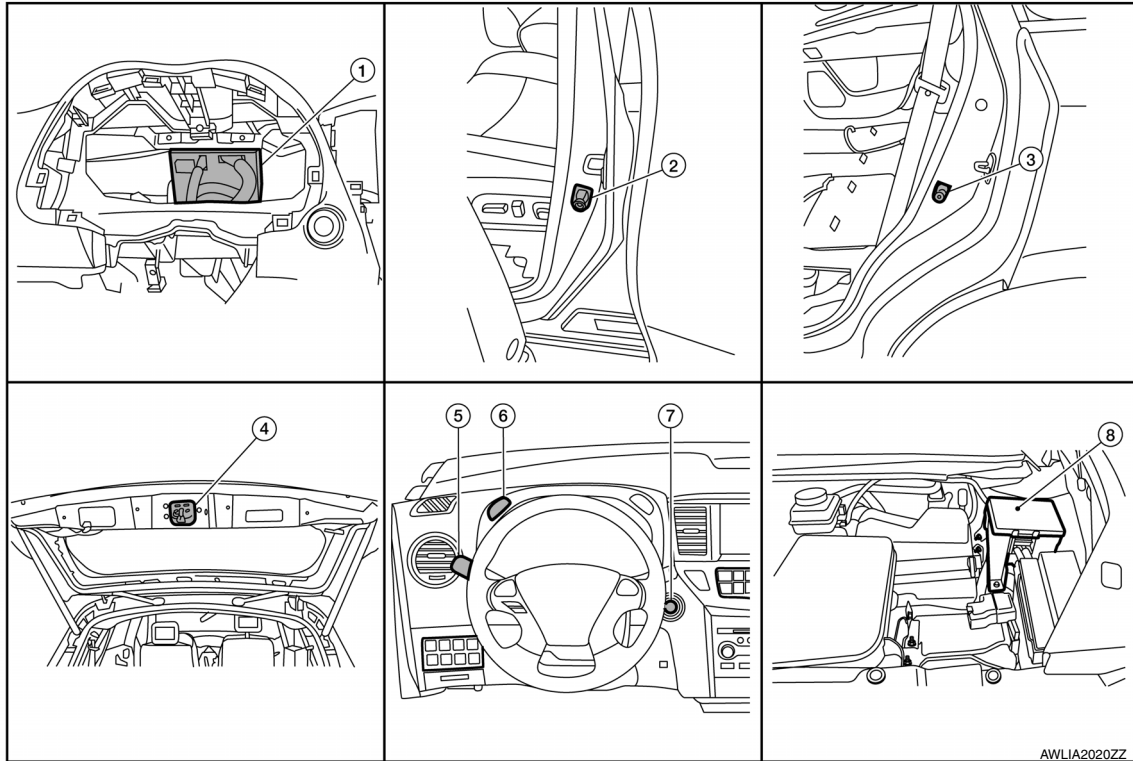

- | | | |
|---|---|-------------------------------------|
| 1. BCM (view with combination meter removed) | 2. Front door switch LH (RH similar) | 3. Rear door switch LH (RH similar) |
| 4. Back door lock assembly (door ajar switch) | 5. Combination switch (lighting and turn signal switch) | 6. Illumination control switch |
| 7. Push-button ignition switch | 8. IPDM E/R | |

Component Description

INFOID:000000009175427

Part name	Description
BCM	The BCM monitors the combination switch (lighting and turn signal switch) position. The BCM requests via CAN communication that the IPDM E/R activate the tail lamp relay.
IPDM E/R	The IPDM E/R activates the tail lamp relay based on inputs received from the BCM via the CAN communication.
Push button ignition switch	Provides ignition status to the BCM.
Door switches	Provides door OPEN/CLOSED status to the BCM.
Combination switch (lighting and turn signal switch)	The combination switch (lighting and turn signal switch) provides input to the BCM about the combination switch (lighting and turn signal switch) position.
Back door lock assembly (door ajar switch)	Provides back door OPEN/CLOSED status to the BCM.
Illumination control switch	Controls the meter and illumination system brightness.

SYSTEM

< SYSTEM DESCRIPTION >

SYSTEM

INTERIOR ROOM LAMP CONTROL SYSTEM

INTERIOR ROOM LAMP CONTROL SYSTEM : System Diagram

INFOID:000000009175428

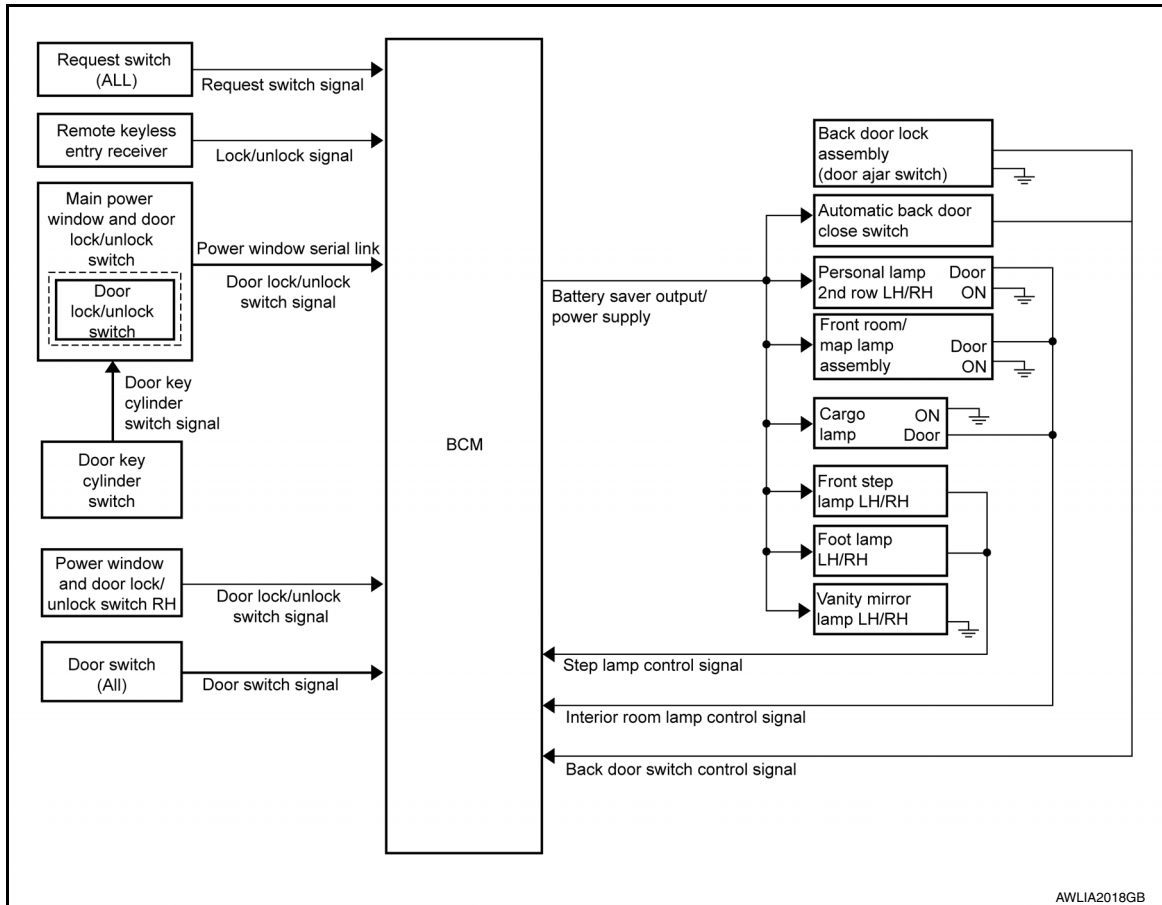

INTERIOR ROOM LAMP CONTROL SYSTEM : System Description

INFOID:000000009175429

OUTLINE

- Front room/map lamp, personal lamp 2nd row and cargo lamp are controlled by the interior room lamp timer control function of the BCM when the lamp switch is in the DOOR position.
- Step lamps (if equipped) and foot lamps (if equipped) are controlled by the step lamp control function of the BCM.
- Push-button ignition switch illumination is controlled by the push-button ignition switch illumination control function of BCM.
- Interior room lamps are illuminated by the welcome light function of Intelligent Key system. Refer to [DLK-33, "WELCOME LIGHT FUNCTION : System Description"](#).

ROOM LAMP TIMER OPERATION

When the interior room lamp switch is in the DOOR position and when all conditions below are met, the BCM begins timer control (maximum 30 seconds) for interior room lamp ON/OFF.

- When the front door LH is unlocked [with Intelligent Key, main power window and door lock/unlock switch, power window and door lock/unlock switch RH or front door lock assembly LH (key cylinder switch)].
- When a door opens → closes.

Timer control is cancelled under the following conditions:

- When the front door LH is locked [with Intelligent Key, main power window and door lock/unlock switch, power window and door lock/unlock switch RH or front door lock assembly LH (key cylinder switch)].
- A door is opened (door switch turns ON).
- Ignition switch is turned ON.

INTERIOR LAMP BATTERY SAVER CONTROL

SYSTEM

< SYSTEM DESCRIPTION >

If an interior lamp is left ON and does not turn OFF even when the doors are closed, the BCM turns off power to the interior lamps automatically to save the battery 10 minutes after the ignition switch is turned OFF. The BCM controls power or ground to all interior lamps.

Vanity lamps (if equipped) are controlled by the battery saver control function of the BCM.

After the battery saver system turns the lamps OFF, the lamps will illuminate again when:

- A signal is received from an Intelligent Key or main power window and door lock/unlock switch, power window and door lock/unlock switch RH or when the front door lock assembly LH (key cylinder switch) is locked or unlocked.
- A door is opened or closed.

ILLUMINATION CONTROL SYSTEM

ILLUMINATION CONTROL SYSTEM : System Diagram

INFOID:000000009175430

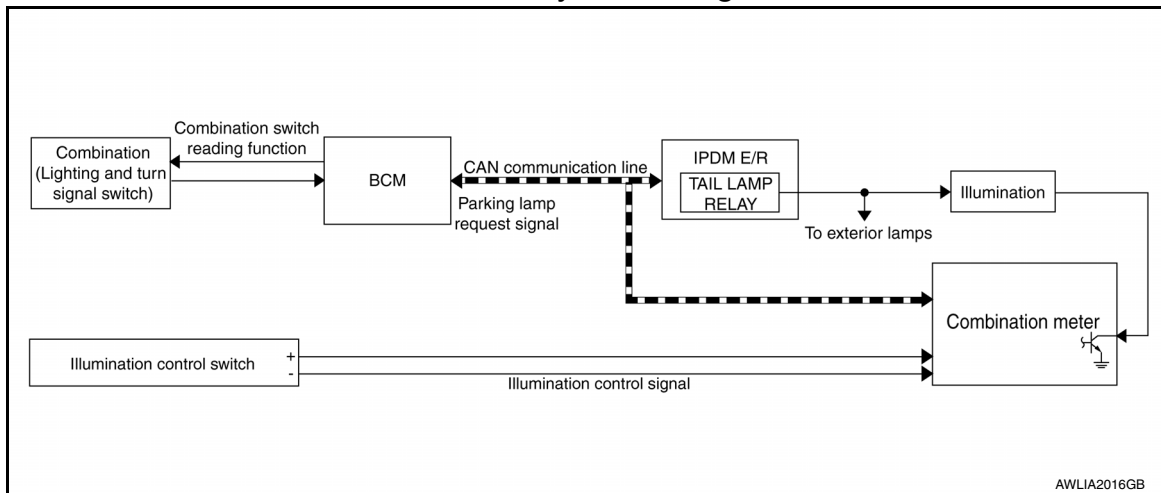

ILLUMINATION CONTROL SYSTEM : System Description

INFOID:000000009175431

The illumination lamps operation is dependent upon the position of the combination switch (lighting and turn signal switch). When the combination switch (lighting and turn signal switch) is placed in the AUTO (if equipped) or parking lamp position the BCM (body control module) receives input requesting the parking lamps to illuminate. This input is communicated to the IPDM E/R (intelligent power distribution module engine room) via the CAN communication lines. The CPU (central processing unit) of the IPDM E/R controls the tail lamp relay coil. When energized, this relay directs power to the parking and illumination lamps, which then illuminate. The illumination brightness can be controlled by the illumination control switch.

BATTERY SAVER CONTROL

When the combination switch (lighting and turn signal switch) is in the AUTO (if equipped) or parking lamp position and the ignition switch is turned from ON or ACC to OFF, the battery saver control feature is activated. Under this condition, the illumination lamps remain illuminated for 45 seconds unless the combination switch (lighting and turn signal switch) position is changed. If the combination switch (lighting and turn signal switch) position is changed, then the illumination lamps are turned off after a 30 second delay. When the combination switch (lighting and turn signal switch) is turned from OFF to AUTO (if equipped) or parking lamp position after illumination lamps have been turned off by the battery saver control, the illumination lamps illuminate again.

DIAGNOSIS SYSTEM (BCM)

< SYSTEM DESCRIPTION >

DIAGNOSIS SYSTEM (BCM)

COMMON ITEM

COMMON ITEM : CONSULT Function (BCM - COMMON ITEM)

INFOID:000000009764020

CAUTION:

After disconnecting the CONSULT vehicle interface (VI) from the data link connector, the ignition must be cycled OFF → ON (for at least 5 seconds) → OFF. If this step is not performed, the BCM may not go to "sleep mode", potentially causing a discharged battery and no-start condition.

APPLICATION ITEM

CONSULT performs the following functions via CAN communication with BCM.

Direct Diagnostic Mode	Description
Ecu Identification	The BCM part number is displayed.
Self Diagnostic Result	The BCM self diagnostic results are displayed.
Data Monitor	The BCM input/output data is displayed in real time.
Active Test	The BCM activates outputs to test components.
Work support	The settings for BCM functions can be changed.
Configuration	<ul style="list-style-type: none"> The vehicle specification can be read and saved. The vehicle specification can be written when replacing BCM.
CAN Diag Support Mntr	The result of transmit/receive diagnosis of CAN communication is displayed.

SYSTEM APPLICATION

BCM can perform the following functions.

System	Sub System	Direct Diagnostic Mode						
		Ecu Identification	Self Diagnostic Result	Data Monitor	Active Test	Work support	Configuration	CAN Diag Support Mntr
Door lock	DOOR LOCK		×	×	×	×		
Rear window defogger	REAR DEFOGGER			×	×	×		
Warning chime	BUZZER			×	×			
Interior room lamp timer	INT LAMP			×	×	×		
Exterior lamp	HEADLAMP			×	×	×		
Wiper and washer	WIPER			×	×	×		
Turn signal and hazard warning lamps	FLASHER			×	×			
Air conditioner	AIR CONDITIONER			×				
Intelligent Key system	INTELLIGENT KEY		×	×	×	×		
Combination switch	COMB SW			×				
BCM	BCM	×	×			×	×	×
Immobilizer	IMMU		×	×	×			
Interior room lamp battery saver	BATTERY SAVER			×	×			
Back door open	TRUNK			×				
Vehicle security system	THEFT ALM			×	×	×		
RAP system	RETAINED PWR			×				

DIAGNOSIS SYSTEM (BCM)

< SYSTEM DESCRIPTION >

System	Sub System	Direct Diagnostic Mode						
		Ecu Identification	Self Diagnostic Result	Data Monitor	Active Test	Work support	Configuration	CAN Diag Support Mntr
Signal buffer system	SIGNAL BUFFER			x				
TPMS	AIR PRESSURE MONITOR		x	x	x	x		

INT LAMP

INT LAMP : CONSULT Function (BCM - INT LAMP)

INFOID:000000009764022

CAUTION:

After disconnecting the CONSULT vehicle interface (VI) from the data link connector, the ignition must be cycled OFF → ON (for at least 5 seconds) → OFF. If this step is not performed, the BCM may not go to "sleep mode", potentially causing a discharged battery and no-start condition.

DATA MONITOR

Monitor Item [Unit]	Description
REQ SW -DR [On/Off]	Indicates condition of door request switch LH.
REQ SW -AS [On/Off]	Indicates condition of door request switch RH.
PUSH -SW [On/Off]	Indicates condition of push-button ignition switch.
UNLK SEN -DR [On/Off]	Indicates condition of door unlock sensor.
DOOR SW-DR [On/Off]	Indicates condition of front door switch LH.
DOOR SW-AS [On/Off]	Indicates condition of front door switch RH.
DOOR SW-RR [On/Off]	Indicates condition of rear door switch RH.
DOOR SW-RL [On/Off]	Indicates condition of rear door switch LH.
DOOR SW-BK [On/Off]	Indicates condition of back door switch.
CDL LOCK SW [On/Off]	Indicates condition of lock signal from door lock and unlock switch.
CDL UNLOCK SW [On/Off]	Indicates condition of unlock signal from door lock and unlock switch.
KEY CYL LK-SW [On/Off]	Indicates condition of lock signal from door key cylinder switch.
KEY CYL UN-SW [On/Off]	Indicates condition of unlock signal from door key cylinder switch.
RKE-LOCK [On/Off]	Indicates condition of lock signal from Intelligent Key.
RKE-UNLOCK [On/Off]	Indicates condition of unlock signal from Intelligent Key.

ACTIVE TEST

Test Item	Description
INT LAMP	This test is able to check interior room lamp operation [On/Off].
STEP LAMP TEST	This test is able to check step lamp operation [On/Off].

WORK SUPPORT

NOTE:

The items listed below are the only applicable Work Support items for this vehicle. If other items are displayed on CONSULT, do not use or change the setting for these other items.

DIAGNOSIS SYSTEM (BCM)

< SYSTEM DESCRIPTION >

Support Item	Setting	Description
SCENARIO LIGHTING SETTING	On	NOTE: Do not use this function since interior room lamp control is changed.
	Off*	
SET I/L D-UNLCK INTCON	On	Interior room lamp timer function ON.
	Off*	Interior room lamp timer function OFF.
FOG LAMP OVERRIDE	On*	Fog lamp override function ON.
	Off	Fog lamp override function OFF.

*: Initial setting

BATTERY SAVER

BATTERY SAVER : CONSULT Function (BCM - BATTERY SAVER)

INFOID:000000009764023

CAUTION:

After disconnecting the CONSULT vehicle interface (VI) from the data link connector, the ignition must be cycled OFF → ON (for at least 5 seconds) → OFF. If this step is not performed, the BCM may not go to "sleep mode", potentially causing a discharged battery and no-start condition.

DATA MONITOR

Monitor Item [Unit]	Description
REQ SW -DR [On/Off]	Indicates condition of door request switch LH.
REQ SW -AS [On/Off]	Indicates condition of door request switch RH.
PUSH SW [On/Off]	Indicates condition push-button ignition switch.
UNLK SEN -DR [On/Off]	Indicates condition of door unlock sensor.
DOOR SW-DR [On/Off]	Indicates condition of front door switch LH.
DOOR SW-AS [On/Off]	Indicates condition of front door switch RH.
DOOR SW-RR [On/Off]	Indicates condition of rear door switch RH.
DOOR SW-RL [On/Off]	Indicates condition of rear door switch LH.
DOOR SW-BK [On/Off]	Indicates condition of back door switch.
CDL LOCK SW [On/Off]	Indicates condition of lock signal from door lock and unlock switch.
CDL UNLOCK SW [On/Off]	Indicates condition of unlock signal from door lock and unlock switch.
KEY CYL LK-SW [On/Off]	Indicates condition of lock signal from door key cylinder switch.
KEY CYL UN-SW [On/Off]	Indicates condition of unlock signal from door key cylinder switch.
RKE-LOCK [On/Off]	Indicates condition of lock signal from Intelligent Key.
RKE-UNLOCK [On/Off]	Indicates condition of unlock signal from Intelligent Key.

ACTIVE TEST

Test item	Description
BATTERY SAVER	This test is able to check battery saver operation [On/Off].

BCM

< ECU DIAGNOSIS INFORMATION >

ECU DIAGNOSIS INFORMATION

BCM

List of ECU Reference

INFOID:000000009175435

ECU	Reference
BCM	BCS-30. "Reference Value"
	BCS-50. "Fail Safe"
	BCS-50. "DTC Inspection Priority Chart"
	BCS-52. "DTC Index"

A
B
C
D
E
F
G
H
I
J
K
L
M
N
O
P

INL

INTERIOR ROOM LAMP CONTROL SYSTEM

< WIRING DIAGRAM >

WIRING DIAGRAM

INTERIOR ROOM LAMP CONTROL SYSTEM

Wiring Diagram

INFOID:000000009175436

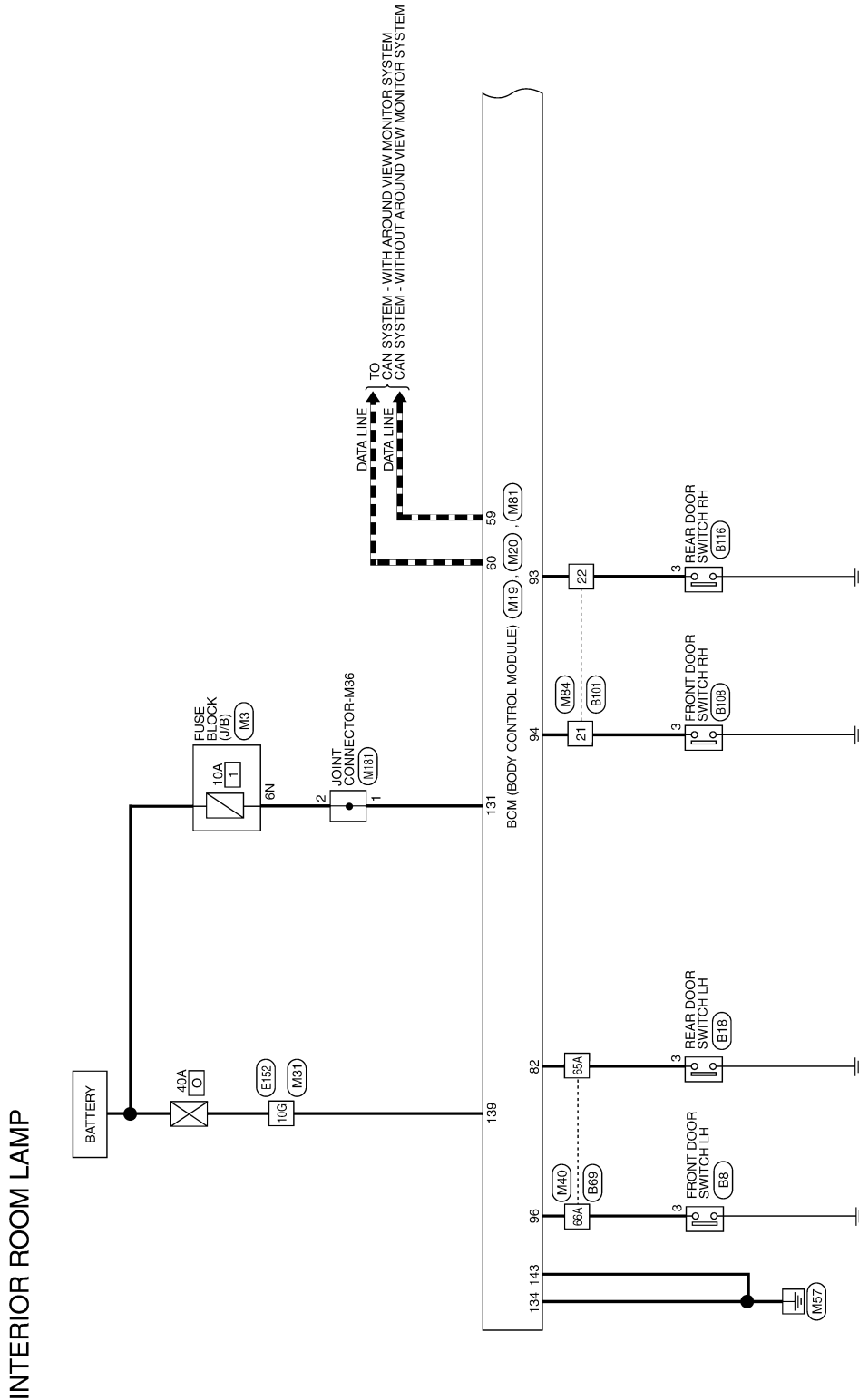

ABLWA2223GB

INTERIOR ROOM LAMP CONTROL SYSTEM

< WIRING DIAGRAM >

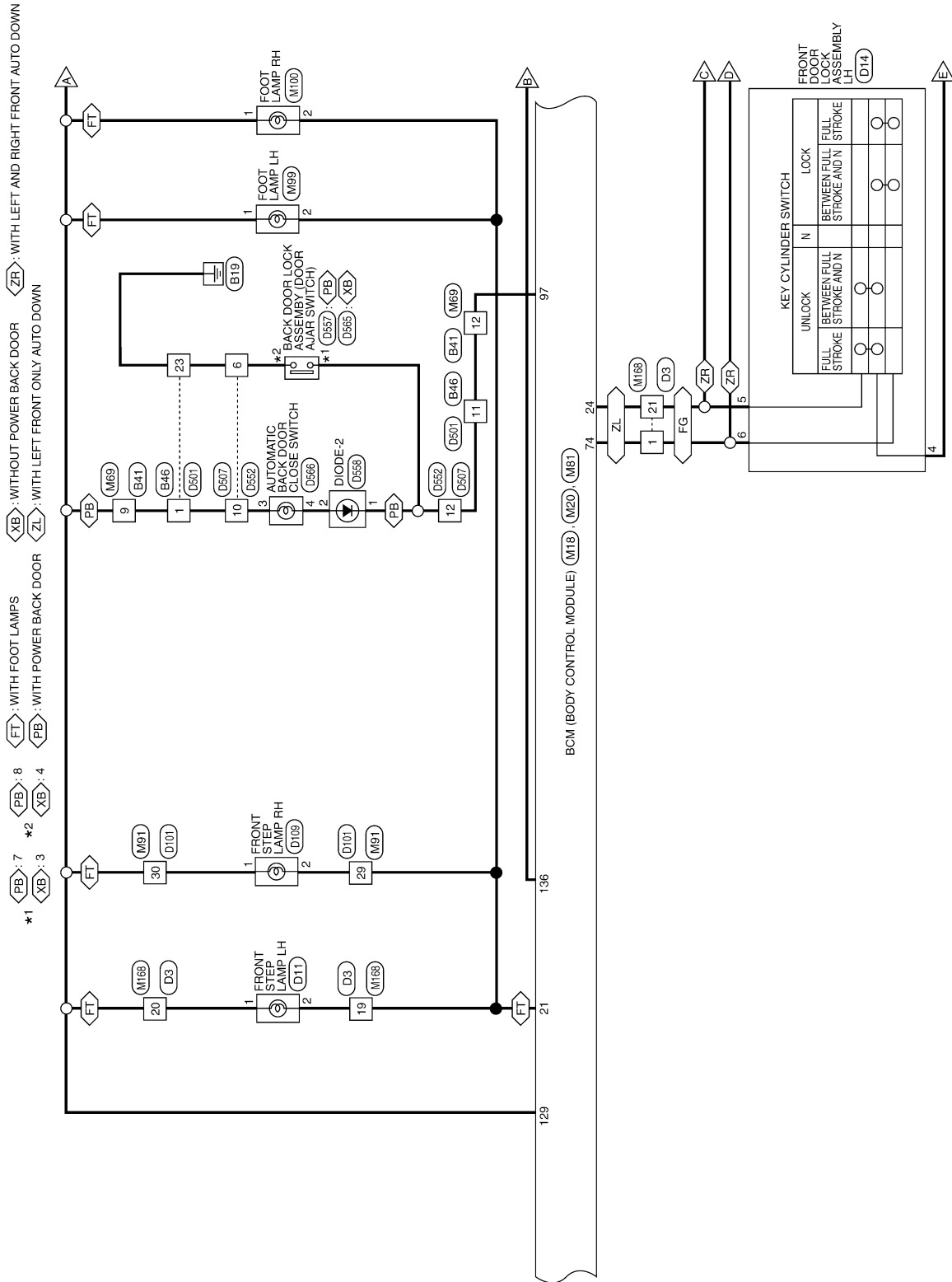

ABLWA2224GB

A
B
C
D
E
F
G
H
I
J
K
L
M
N
O
P

INL

INTERIOR ROOM LAMP CONTROL SYSTEM

< WIRING DIAGRAM >

ZL : WITH LEFT FRONT ONLY AUTO DOWN
 ZR : WITH LEFT AND RIGHT FRONT AUTO DOWN

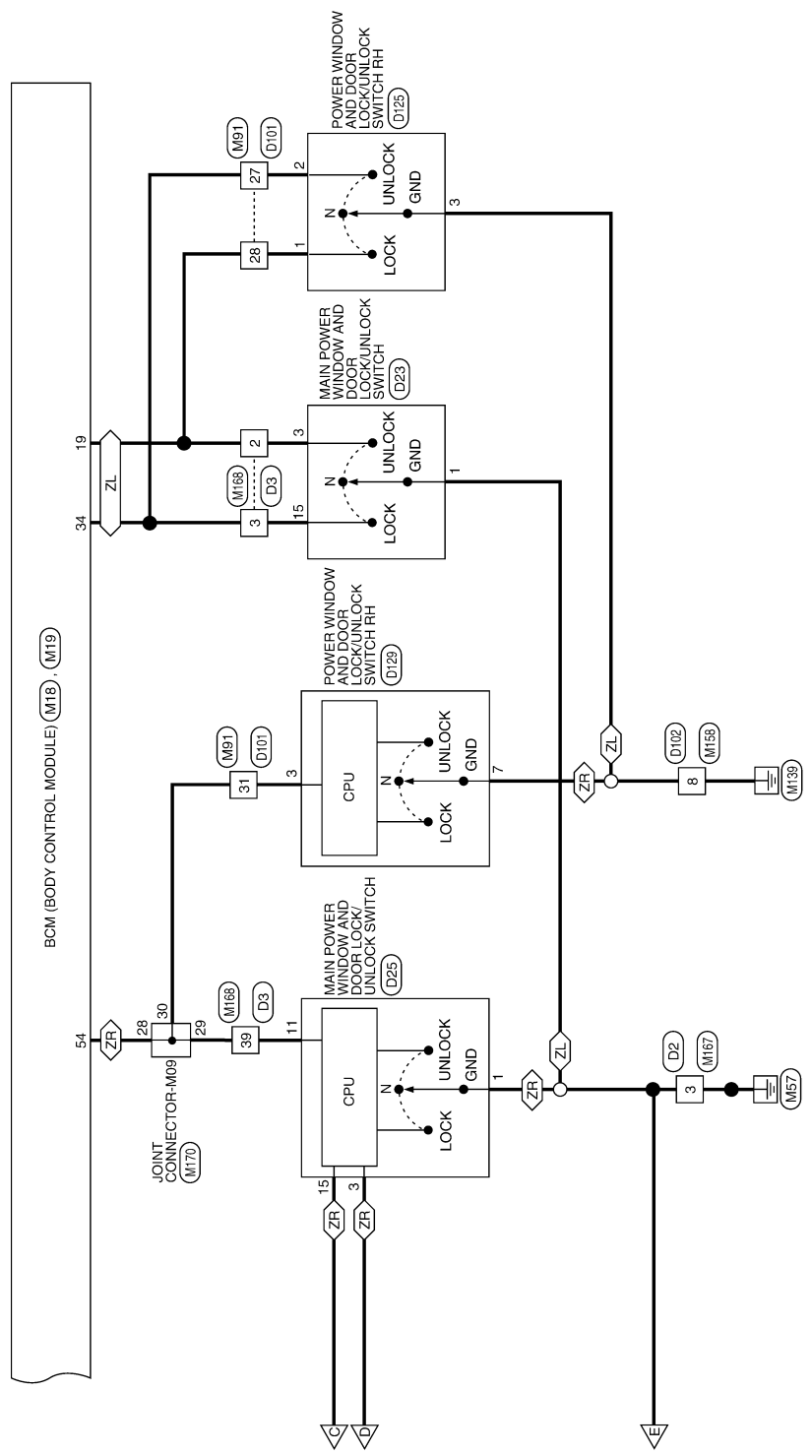
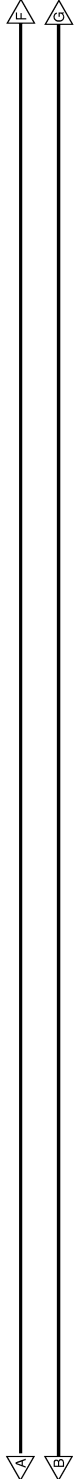

ABLWA2225GB

INTERIOR ROOM LAMP CONTROL SYSTEM

< WIRING DIAGRAM >

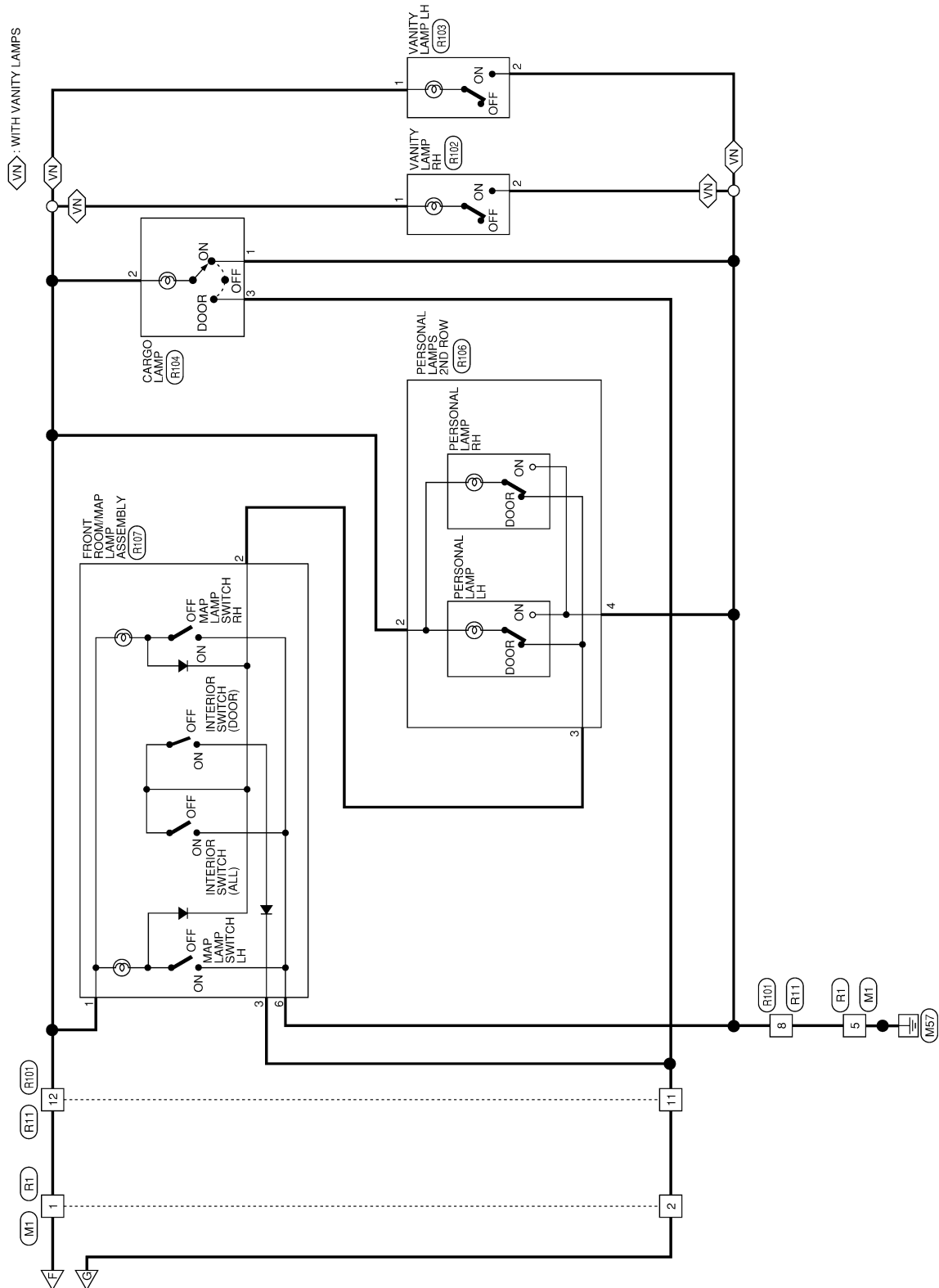

AALWA0493GB

A
B
C
D
E
F
G
H
I
J
K
INL
M
N
O
P

INTERIOR ROOM LAMP CONTROL SYSTEM

< WIRING DIAGRAM >

INTERIOR ROOM LAMP CONNECTORS

Connector No.	M1
Connector Name	WIRE TO WIRE
Connector Color	WHITE



Terminal No.	Color of Wire	Signal Name
1	SB	-
2	LG	-
5	B	-

Connector No.	M3
Connector Name	FUSE BLOCK (J/B)
Connector Color	WHITE

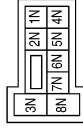

Terminal No.	Color of Wire	Signal Name
6N	W	-

Connector No.	M18
Connector Name	BCM (BODY CONTROL MODULE)
Connector Color	GREEN

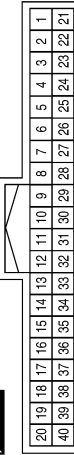

Terminal No.	Color of Wire	Signal Name
19	Y	CENTRAL DOOR LOCK SW
21	W	STEP LAMP CONT
24	SB	DOOR KEY/C UNLOCK SW
34	BR	CENTRAL DOOR UNLOCK SW

Connector No.	M19
Connector Name	BCM (BODY CONTROL MODULE)
Connector Color	BLACK



Terminal No.	Color of Wire	Signal Name
54	W	PW LIN/COM
59	P	CAN-L
60	L	CAN-H
74	BR	DOOR KEY/C LOCK SW

Connector No.	M20
Connector Name	BCM (BODY CONTROL MODULE)
Connector Color	GRAY



Terminal No.	Color of Wire	Signal Name
82	W	RL DOOR SW
93	R	RR DOOR SW
94	G	AS DOOR SW
96	BG	DR DOOR SW
97	W	BACK DOOR SW

INTERIOR ROOM LAMP CONTROL SYSTEM

< WIRING DIAGRAM >

Connector No.	M69
Connector Name	WIRE TO WIRE
Connector Color	WHITE

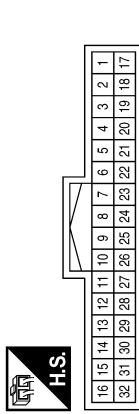

Terminal No.	Color of Wire	Signal Name
9	SB	-
12	W	-

Connector No.	M40
Connector Name	WIRE TO WIRE
Connector Color	GRAY

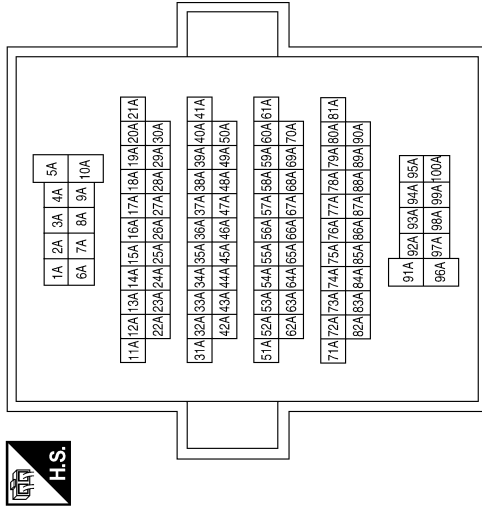

Terminal No.	Color of Wire	Signal Name
65A	W	-
66A	BG	-

Connector No.	M31
Connector Name	WIRE TO WIRE
Connector Color	WHITE

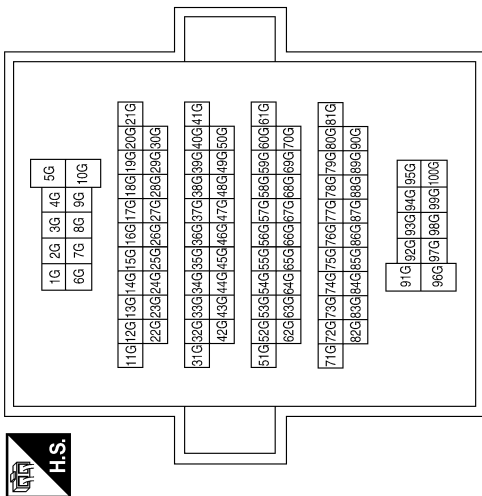

Terminal No.	Color of Wire	Signal Name
10G	W	-

A
B
C
D
E
F
G
H
I
J
K
L
M
N
O
P

INL

ABLIA5083GB

INTERIOR ROOM LAMP CONTROL SYSTEM

< WIRING DIAGRAM >

Connector No.	M91
Connector Name	WIRE TO WIRE
Connector Color	WHITE



1	2	3	4	5	6	7	8	9	10	11	12	13	14	15	16
17	18	19	20	21	22	23	24	25	26	27	28	29	30	31	32

Terminal No.	Color of Wire	Signal Name
27	BR	-
28	Y	-
29	W	-
30	SB	-
31	W	-

Connector No.	M84
Connector Name	WIRE TO WIRE
Connector Color	WHITE



16	15	14	13	12	11	10	9	8	7	6	5	4	3	2	1
32	31	30	29	28	27	26	25	24	23	22	21	20	19	18	17

Terminal No.	Color of Wire	Signal Name
21	G	-
22	R	-

Connector No.	M81
Connector Name	BCM (BODY CONTROL MODULE)
Connector Color	WHITE



137	136	135	134	133	132	131	130	129
143	142	141	140	139	138			

Terminal No.	Color of Wire	Signal Name
129	SB	BATTERY SAVER OUTPUT
131	W	BAT BCM FUSE
134	B	GND 2
136	LG	ROOM LAMP CONT
139	W	BAT POWER F/L
143	B	GND 1

Connector No.	M158
Connector Name	WIRE TO WIRE
Connector Color	WHITE



1	2	3	4
5	6	7	8
9	10		

Connector No.	M100
Connector Name	FOOT LAMP RH
Connector Color	BLACK



Connector No.	M99
Connector Name	FOOT LAMP LH
Connector Color	BLACK



Terminal No.	Color of Wire	Signal Name
8	B	-

Terminal No.	Color of Wire	Signal Name
1	SB	-
2	W	-

Terminal No.	Color of Wire	Signal Name
1	SB	-
2	W	-

ABLIA5084GB

INTERIOR ROOM LAMP CONTROL SYSTEM

< WIRING DIAGRAM >

Terminal No.	Color of Wire	Signal Name
1	BR	-
2	Y	-
3	BR	-
19	W	-
20	SB	-
21	SB	-
39	W	-

Connector No.	M168
Connector Name	WIRE TO WIRE
Connector Color	WHITE

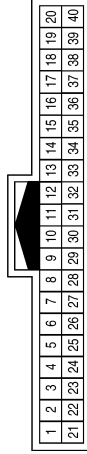

Connector No.	M167
Connector Name	WIRE TO WIRE
Connector Color	WHITE

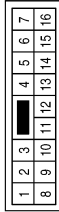

Terminal No.	Color of Wire	Signal Name
3	B	-

Connector No.	E152
Connector Name	WIRE TO WIRE
Connector Color	WHITE

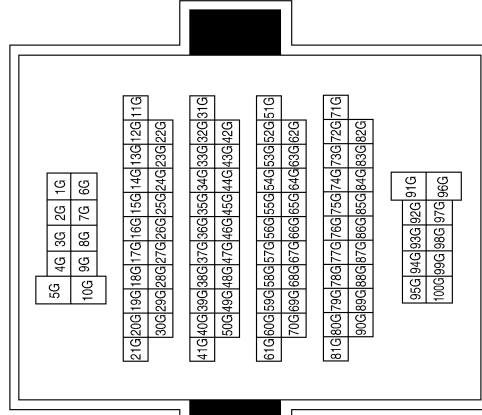

Connector No.	M181
Connector Name	JOINT CONNECTOR-M36
Connector Color	WHITE



Connector No.	M170
Connector Name	JOINT CONNECTOR-M09
Connector Color	WHITE

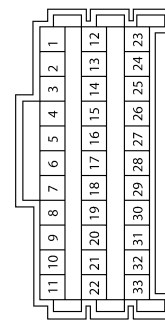

Terminal No.	Color of Wire	Signal Name
1	W	-
2	W	-

Terminal No.	Color of Wire	Signal Name
28	W	-
29	W	-
30	W	-

Terminal No.	Color of Wire	Signal Name
10G	P	-

ABLIA5085GB

A
B
C
D
E
F
G
H
I
J
K
L
M
N
O
P

INL

INTERIOR ROOM LAMP CONTROL SYSTEM

< WIRING DIAGRAM >

Connector No.	B8
Connector Name	FRONT DOOR SWITCH LH
Connector Color	WHITE

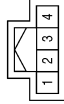

Terminal No.	Color of Wire	Signal Name
3	L	-

Connector No.	B18
Connector Name	REAR DOOR SWITCH LH
Connector Color	WHITE

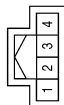

Terminal No.	Color of Wire	Signal Name
3	SB	-

Connector No.	B41
Connector Name	WIRE TO WIRE
Connector Color	WHITE

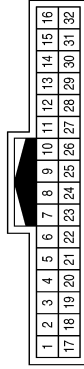

Terminal No.	Color of Wire	Signal Name
9	V	-
12	G	-

Connector No.	B46
Connector Name	WIRE TO WIRE
Connector Color	WHITE



Terminal No.	Color of Wire	Signal Name
1	V	-
11	G	-
23	GR	-

Connector No.	B69
Connector Name	WIRE TO WIRE
Connector Color	GRAY

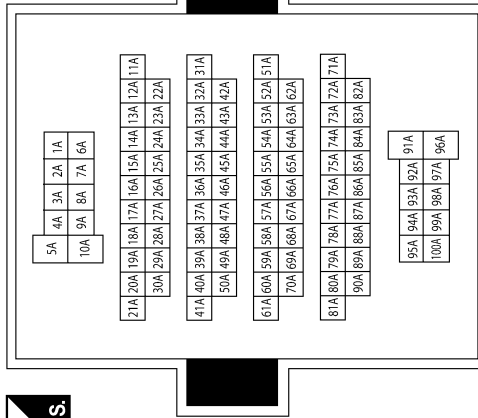

Terminal No.	Color of Wire	Signal Name
65A	SB	-
66A	L	-

Connector No.	B101
Connector Name	WIRE TO WIRE
Connector Color	WHITE



Terminal No.	Color of Wire	Signal Name
21	LG	-
22	LG	-

ABLIA5086GB

INTERIOR ROOM LAMP CONTROL SYSTEM

< WIRING DIAGRAM >

Connector No.	R1
Connector Name	WIRE TO WIRE
Connector Color	WHITE

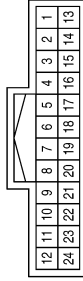

Terminal No.	Color of Wire	Signal Name
1	G	-
2	R	-
5	B	-

Connector No.	B116
Connector Name	REAR DOOR SWITCH RH
Connector Color	WHITE

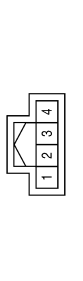

Terminal No.	Color of Wire	Signal Name
3	LG	-

Connector No.	B108
Connector Name	FRONT DOOR SWITCH RH
Connector Color	WHITE

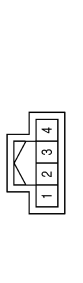

Terminal No.	Color of Wire	Signal Name
3	LG	-

Connector No.	R102
Connector Name	VANITY LAMP RH
Connector Color	WHITE



Terminal No.	Color of Wire	Signal Name
1	G	-
2	B	-

Connector No.	R101
Connector Name	WIRE TO WIRE
Connector Color	WHITE

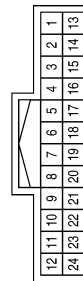

Terminal No.	Color of Wire	Signal Name
8	B	-
11	R	-
12	G	-

Connector No.	R11
Connector Name	WIRE TO WIRE
Connector Color	WHITE

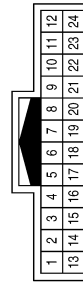

Terminal No.	Color of Wire	Signal Name
8	B	-
11	R	-
12	G	-

ABLIA5087GB

A
B
C
D
E
F
G
H
I
J
K
L
M
N
O
P



INTERIOR ROOM LAMP CONTROL SYSTEM

< WIRING DIAGRAM >

Connector No.	R103
Connector Name	VANITY LAMP LH
Connector Color	WHITE



Terminal No.	Color of Wire	Signal Name
1	G	-
2	B	-

Connector No.	R104
Connector Name	CARGO LAMP
Connector Color	WHITE



Terminal No.	Color of Wire	Signal Name
1	B	-
2	G	-
3	R	-

Connector No.	R106
Connector Name	PERSONAL LAMPS 2ND ROW
Connector Color	WHITE

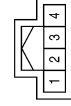

Terminal No.	Color of Wire	Signal Name
2	G	-
3	L	-
4	B	-

Connector No.	R107
Connector Name	FRONT ROOM/MAP LAMP ASSEMBLY
Connector Color	WHITE

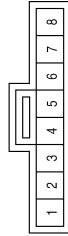

Terminal No.	Color of Wire	Signal Name
1	B	-
2	L	-
3	R	-
6	B	-

Connector No.	D2
Connector Name	WIRE TO WIRE
Connector Color	WHITE

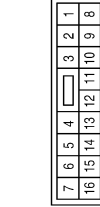

Terminal No.	Color of Wire	Signal Name
3	B	-

Connector No.	D3
Connector Name	WIRE TO WIRE
Connector Color	WHITE

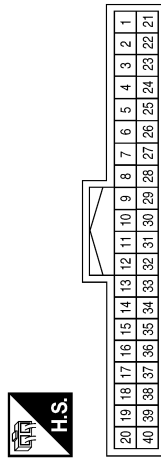

Terminal No.	Color of Wire	Signal Name
1	BR	-
2	Y	-
3	BR	-
19	Y	-
20	LG	-
21	SB	-
39	Y	-

INTERIOR ROOM LAMP CONTROL SYSTEM

< WIRING DIAGRAM >

Connector No.	D11
Connector Name	FRONT STEP LAMP LH
Connector Color	WHITE



Terminal No.	Color of Wire	Signal Name
1	LG	-
2	Y	-

Connector No.	D14
Connector Name	FRONT DOOR LOCK ASSEMBLY LH
Connector Color	GRAY

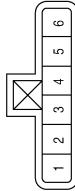

Terminal No.	Color of Wire	Signal Name
4	B	-
5	SB	-
6	BR	-

Connector No.	D23
Connector Name	MAIN POWER WINDOW AND DOOR LOCK/UNLOCK SWITCH (WITH LEFT FRONT ONLY AUTO DOWN)
Connector Color	WHITE

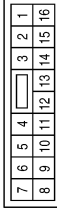

Terminal No.	Color of Wire	Signal Name
1	B	GND
3	Y	LOCK CDL
15	BR	UNLOCK CDL

Connector No.	D25
Connector Name	MAIN POWER WINDOW AND DOOR LOCK/UNLOCK SWITCH (WITH LEFT AND RIGHT FRONT AUTO UP/DOWN)
Connector Color	WHITE

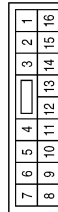

Terminal No.	Color of Wire	Signal Name
1	B	GND
3	BR	KEY CYL LOCK
11	Y	COM
15	SB	UNLOCK CDL

Connector No.	D101
Connector Name	WIRE TO WIRE
Connector Color	WHITE

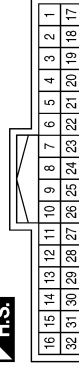

Terminal No.	Color of Wire	Signal Name
27	BR	-
28	Y	-
29	Y	-
30	LG	-
31	Y	-

Connector No.	D102
Connector Name	WIRE TO WIRE
Connector Color	WHITE



Terminal No.	Color of Wire	Signal Name
8	B	-

ABLIA5089GB

A B C D E F G H I J K L M N O P



INTERIOR ROOM LAMP CONTROL SYSTEM

< WIRING DIAGRAM >

Connector No.	D109
Connector Name	FRONT STEP LAMP RH
Connector Color	WHITE



Terminal No.	Color of Wire	Signal Name
1	LG	-
2	Y	-

Connector No.	D125
Connector Name	POWER WINDOW AND DOOR LOCK/UNLOCK SWITCH RH (WITH LEFT FRONT ONLY AUTO DOWN)
Connector Color	WHITE

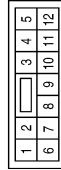

Terminal No.	Color of Wire	Signal Name
1	Y	-
2	BR	-
3	B	-

Connector No.	D129
Connector Name	POWER WINDOW AND DOOR LOCK/UNLOCK SWITCH RH (WITH LEFT AND RIGHT FRONT AUTO UP/DOWN)
Connector Color	WHITE

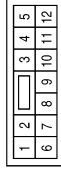

Terminal No.	Color of Wire	Signal Name
3	Y	COM
7	B	GND

Connector No.	D501
Connector Name	WIRE TO WIRE
Connector Color	WHITE

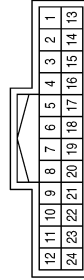

Terminal No.	Color of Wire	Signal Name
1	BR	-
11	LG	-(WITHOUT POWER BACK DOOR)
11	P	-(WITH POWER BACK DOOR)
23	B	-

Connector No.	D507
Connector Name	WIRE TO WIRE
Connector Color	WHITE

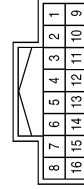

Terminal No.	Color of Wire	Signal Name
6	B	-
10	BR	-
12	LG	-(WITHOUT POWER BACK DOOR)
12	P	-(WITH POWER BACK DOOR)

Connector No.	D552
Connector Name	WIRE TO WIRE
Connector Color	WHITE

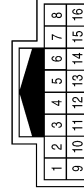

Terminal No.	Color of Wire	Signal Name
6	B	-
10	P	-
12	G	-

ABLIA5090GB

INTERIOR ROOM LAMP CONTROL SYSTEM

< WIRING DIAGRAM >

Connector No.	D565
Connector Name	BACK DOOR LOCK ASSEMBLY (WITHOUT POWER BACK DOOR)
Connector Color	WHITE

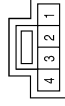

Terminal No.	Color of Wire	Signal Name
3	G	-
4	B	-

Connector No.	D558
Connector Name	DIODE-2
Connector Color	BLACK

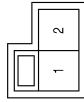

Terminal No.	Color of Wire	Signal Name
1	G	-
2	BR	-

Connector No.	D557
Connector Name	BACK DOOR LOCK ASSEMBLY (WITH POWER BACK DOOR)
Connector Color	WHITE

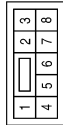

Terminal No.	Color of Wire	Signal Name
7	G	-
8	B	-

Connector No.	D566
Connector Name	AUTOMATIC BACK DOOR CLOSE SWITCH
Connector Color	GREEN

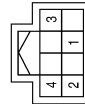

Terminal No.	Color of Wire	Signal Name
3	P	-
4	BR	-

ABLIA5091GB

A
B
C
D
E
F
G
H
I
J
K
INL
M
N
O
P

ILLUMINATION

< WIRING DIAGRAM >

- ◊BA◊ : WITH BASE AUDIO SYSTEM
- ◊CU◊ : WITH CLIMATE CONTROLLED SEAT
- ◊EB◊ : EXCEPT BASE AUDIO SYSTEM
- ◊HF◊ : WITH FRONT HEATED SEATS
- ◊HR◊ : WITH REAR HEATED SEATS
- ◊MK◊ : WITH MID AUDIO SYSTEM
- ◊OB◊ : WITHOUT BOSE AUDIO SYSTEM
- ◊OG◊ : WITH INVERTER SYSTEM
- ◊WB◊ : WITH BOSE AUDIO SYSTEM
- ◊4W◊ : WITH 4-WHEEL DRIVE

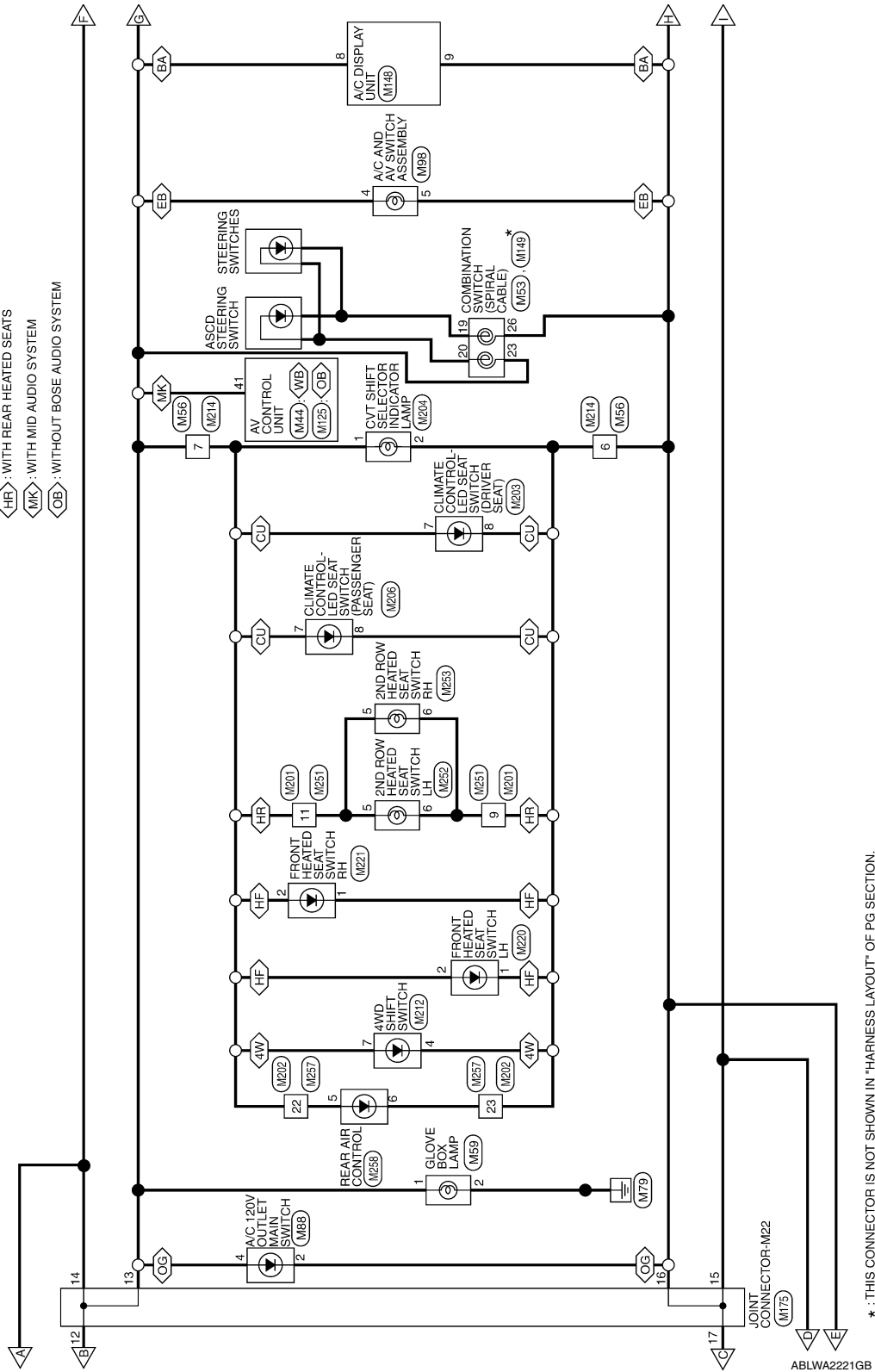

* : THIS CONNECTOR IS NOT SHOWN IN "HARNES LAYOUT" OF PG SECTION.

ABLWA2221GB

A
B
C
D
E
F
G
H
I
J
K
L
M
N
O
P

INL

ILLUMINATION

< WIRING DIAGRAM >

- ◁ AD ▷ : WITH AUTOMATIC DRIVE POSITION
- ◁ BA ▷ : WITH HEATED STEERING WHEEL
- ◁ BA ▷ : WITH TRAILER TOW
- ◁ PB ▷ : WITH POWER BACK DOOR
- ◁ SW ▷ : WITH AUTOMATIC DRIVE POSITIONER
- ◁ TT ▷ : WITH BASE AUDIO SYSTEM
- ◁ XA ▷ : WITHOUT AUTOMATIC DRIVER POSITIONER

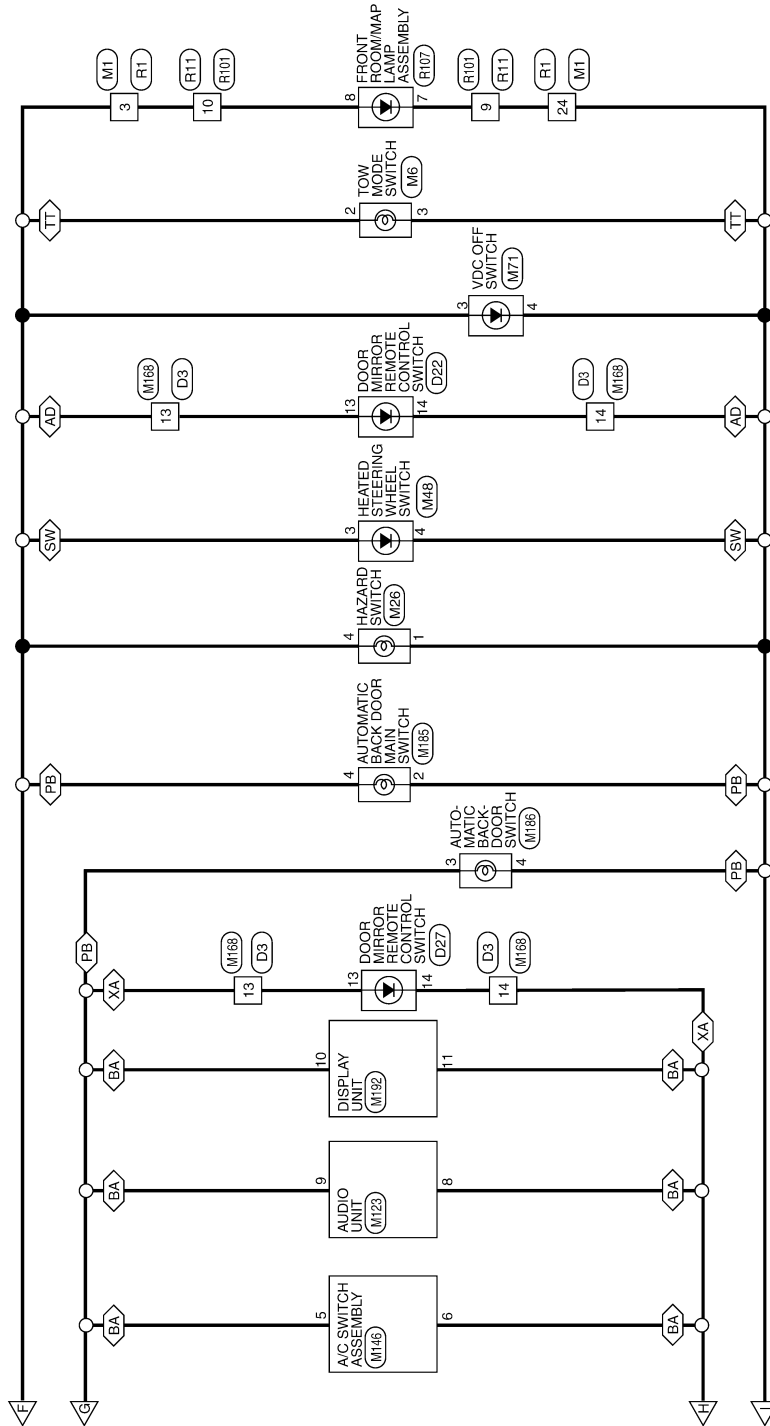

ABLWA2222GB

ILLUMINATION

< WIRING DIAGRAM >

ILLUMINATION CONNECTORS

Connector No.	M1
Connector Name	WIRE TO WIRE
Connector Color	WHITE

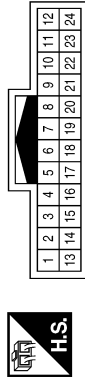

Terminal No.	Color of Wire	Signal Name
3	R	-
24	B	-

Connector No.	M3
Connector Name	FUSE BLOCK (J/B)
Connector Color	WHITE

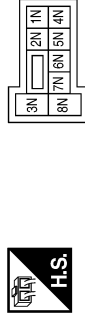

Terminal No.	Color of Wire	Signal Name
6N	W	-

Connector No.	M4
Connector Name	FUSE BLOCK (J/B)
Connector Color	WHITE

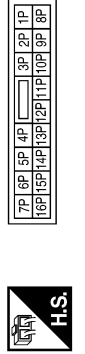

Terminal No.	Color of Wire	Signal Name
8P	BG	-
13P	W	-

Connector No.	M6
Connector Name	TOW MODE SWITCH
Connector Color	GRAY



Terminal No.	Color of Wire	Signal Name
2	R	-
3	B	-

Connector No.	M17
Connector Name	PUSH-BUTTON IGNITION SWITCH
Connector Color	WHITE



Terminal No.	Color of Wire	Signal Name
5	R	-
6	W	-

Connector No.	M18
Connector Name	BCM (BODY CONTROL MODULE)
Connector Color	GREEN

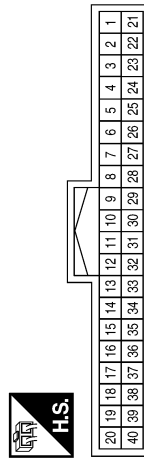

Terminal No.	Color of Wire	Signal Name
10	W	COMBI SW IN 5
11	BG	COMBI SW IN 4
12	R	COMBI SW IN 3
13	G	COMBI SW IN 2
14	P	COMBI SW IN 1

A
B
C
D
E
F
G
H
I
J
K
L
M
N
O
P

INL

ILLUMINATION

< WIRING DIAGRAM >

Connector No.	M23
Connector Name	COMBINATION METER
Connector Color	WHITE

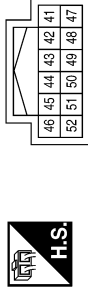

Terminal No.	Color of Wire	Signal Name
42	Y	ILLUMI DOWN SW
47	BR	ILLUMI UP SW
48	G	SW GND

Terminal No.	Color of Wire	Signal Name
48	R	HIGH SIDE START SW LED
59	P	CAN-L
60	L	CAN-H
75	BG	COMBI SW OUT 5
76	P	COMBI SW OUT 4
77	R	COMBI SW OUT 3
78	G	COMBI SW OUT 2
79	W	COMBI SW OUT 1

Connector No.	M19
Connector Name	BCM (BODY CONTROL MODULE)
Connector Color	BLACK

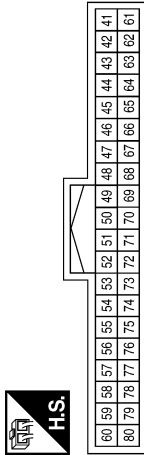

Connector No.	M26
Connector Name	HAZARD SWITCH
Connector Color	WHITE



Terminal No.	Color of Wire	Signal Name
1	B	-
4	R	-

Terminal No.	Color of Wire	Signal Name
1	B	GND 1
2	B	GND 2
21	BG	IGN
22	W	BAT
23	B	ILLUMI CONT OUT
38	P	CAN-L
39	L	CAN-H

Connector No.	M24
Connector Name	COMBINATION METER
Connector Color	WHITE

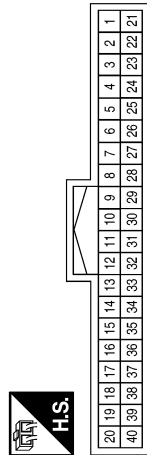

ABLIA5069GB

ILLUMINATION

< WIRING DIAGRAM >

Terminal No.	Color of Wire	Signal Name
10	P	-
11	W	-
12	P	-
13	BG	-
14	G	-

Connector No.	M28
Connector Name	COMBINATION SWITCH
Connector Color	WHITE

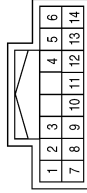

Terminal No.	Color of Wire	Signal Name
2	BG	-
5	R	-
7	R	-
8	W	-
9	G	-

Connector No.	M27
Connector Name	WIRE TO WIRE
Connector Color	WHITE

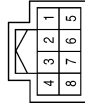

Terminal No.	Color of Wire	Signal Name
1	R	-
2	B	-
3	BR	-
4	Y	-
6	G	-

Connector No.	M32
Connector Name	DIODE-3
Connector Color	BLACK



Terminal No.	Color of Wire	Signal Name
1	W	-
2	B	-

Terminal No.	Color of Wire	Signal Name
10G	W	-
35G	P	-
36G	L	-

Connector No.	M31
Connector Name	WIRE TO WIRE
Connector Color	WHITE

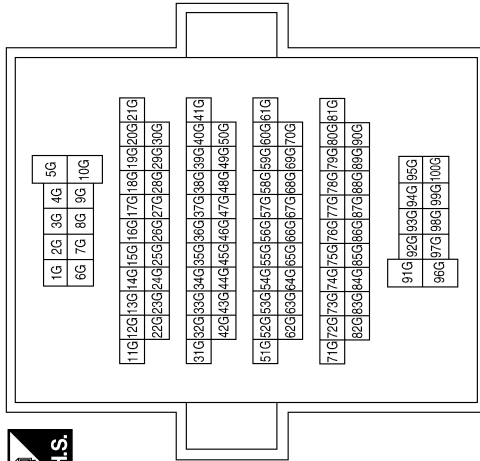

ABLIA5070GB

A
B
C
D
E
F
G
H
I
J
K
L
M
N
O
P

INL

ILLUMINATION

< WIRING DIAGRAM >

Connector No.	M41
Connector Name	JOINT CONNECTOR-M18
Connector Color	WHITE



Terminal No.	Color of Wire	Signal Name
1	P	-
2	P	-

Terminal No.	Color of Wire	Signal Name
89A	L	-
90A	P	-

Connector No.	M40
Connector Name	WIRE TO WIRE
Connector Color	GRAY

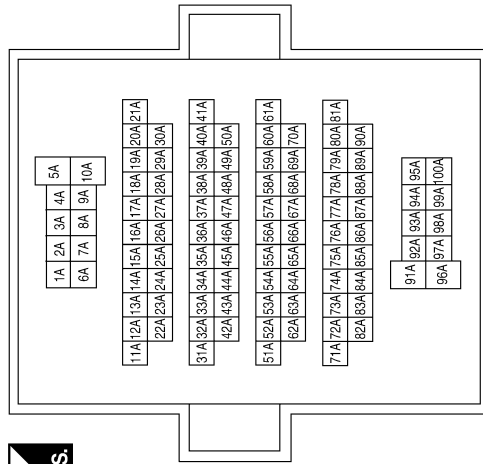

Connector No.	M48
Connector Name	HEATED STEERING WHEEL SWITCH
Connector Color	BLUE

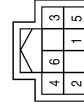

Terminal No.	Color of Wire	Signal Name
3	R	-
4	B	-

Connector No.	M44
Connector Name	AV CONTROL UNIT (WITH MID AUDIO SYSTEM - WITH BOSE AUDIO SYSTEM)
Connector Color	WHITE

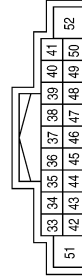

Terminal No.	Color of Wire	Signal Name
41	R	ILL

Connector No.	M43
Connector Name	JOINT CONNECTOR-M17
Connector Color	WHITE

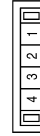

Terminal No.	Color of Wire	Signal Name
1	L	-
2	L	-

ABLIA5071GB

ILLUMINATION

< WIRING DIAGRAM >

Connector No.	M55
Connector Name	WIRE TO WIRE
Connector Color	WHITE

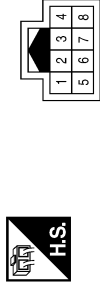

Terminal No.	Color of Wire	Signal Name
1	R	-
2	BR	-
3	BR	-
4	Y	-
6	G	-

Connector No.	M53
Connector Name	COMBINATION SWITCH (SPIRAL CABLE)
Connector Color	YELLOW



Terminal No.	Color of Wire	Signal Name
23	R	-
26	B	-

Connector No.	M49
Connector Name	WIRE TO WIRE
Connector Color	WHITE



Terminal No.	Color of Wire	Signal Name
1	R	-
2	B	-

Connector No.	M68
Connector Name	FUSE BLOCK (J/B)
Connector Color	BROWN



Terminal No.	Color of Wire	Signal Name
1R	R	-

Connector No.	M59
Connector Name	GLOVE BOX LAMP
Connector Color	BLACK



Terminal No.	Color of Wire	Signal Name
1	R	-
2	GR	-

Connector No.	M56
Connector Name	WIRE TO WIRE
Connector Color	WHITE

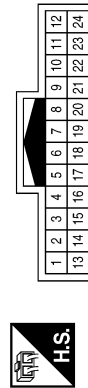

Terminal No.	Color of Wire	Signal Name
6	B	-
7	R	-

ABLIA5072GB

A
B
C
D
E
F
G
H
I
J
K
L
M
N
O
P

INL

ILLUMINATION

< WIRING DIAGRAM >

Connector No.	M71
Connector Name	VDC OFF SWITCH
Connector Color	BLACK



Terminal No.	Color of Wire	Signal Name
3	R	-
4	B	-

Connector No.	M80
Connector Name	BCM (BODY CONTROL MODULE)
Connector Color	BLACK



Terminal No.	Color of Wire	Signal Name
107	W	LOW SIDE START SW LED

Connector No.	M81
Connector Name	BCM (BODY CONTROL MODULE)
Connector Color	WHITE

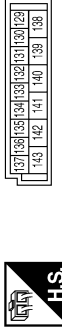

Terminal No.	Color of Wire	Signal Name
131	W	BAT BCM FUSE
134	B	GND 2
139	W	BAT POWER F/L
143	B	GND 1

Connector No.	M83
Connector Name	WIRE TO WIRE
Connector Color	WHITE



Terminal No.	Color of Wire	Signal Name
1	R	-
2	B	-

Connector No.	M84
Connector Name	WIRE TO WIRE
Connector Color	WHITE

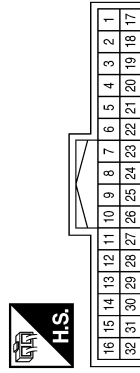

Terminal No.	Color of Wire	Signal Name
17	L	-
18	P	-

Connector No.	M88
Connector Name	A/C 120V OUTLET MAIN SWITCH
Connector Color	BLACK

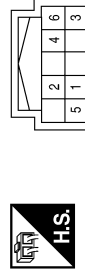

Terminal No.	Color of Wire	Signal Name
2	B	-
4	R	-

ILLUMINATION

< WIRING DIAGRAM >

Connector No.	M123
Connector Name	AUDIO UNIT
Connector Color	WHITE

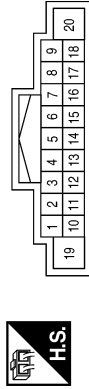

Terminal No.	Color of Wire	Signal Name
8	B	ILL (-)
9	R	ILL (+)

Connector No.	M113
Connector Name	ILLUMINATION CONTROL SWITCH
Connector Color	WHITE



Terminal No.	Color of Wire	Signal Name
1	R	-
2	B	-
3	BR	-
4	Y	-
5	-	-
6	G	-

Connector No.	M98
Connector Name	A/C AND AV SWITCH ASSEMBLY
Connector Color	WHITE

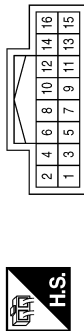

Terminal No.	Color of Wire	Signal Name
4	R	-
5	B	-

Connector No.	M146
Connector Name	A/C SWITCH ASSEMBLY
Connector Color	WHITE

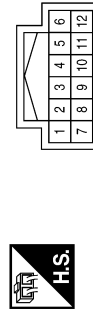

Terminal No.	Color of Wire	Signal Name
5	R	-
6	B	-

Connector No.	M140
Connector Name	TRIP RESET SWITCH
Connector Color	WHITE



Terminal No.	Color of Wire	Signal Name
1	R	-
2	B	-

Connector No.	M125
Connector Name	AV CONTROL UNIT (WITH MID AUDIO SYSTEM - WITHOUT BOSE AUDIO SYSTEM)
Connector Color	WHITE

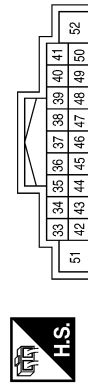

Terminal No.	Color of Wire	Signal Name
41	R	ILL

ABLIA5074GB

A
B
C
D
E
F
G
H
I
J
K
L
M
N
O
P

INL

ILLUMINATION

< WIRING DIAGRAM >

Connector No.	M148
Connector Name	A/C DISPLAY UNIT
Connector Color	BLACK

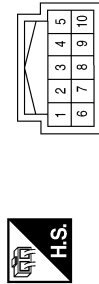

Terminal No.	Color of Wire	Signal Name
8	R	-
9	B	-

Connector No.	M149
Connector Name	COMBINATION SWITCH (SPIRAL CABLE)
Connector Color	GRAY

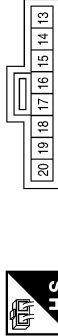

Terminal No.	Color of Wire	Signal Name
19	Y	-
20	W	-

Connector No.	M168
Connector Name	WIRE TO WIRE
Connector Color	WHITE

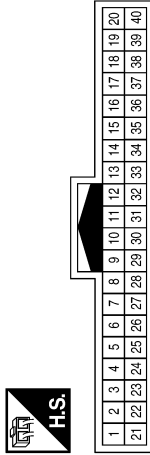

Terminal No.	Color of Wire	Signal Name
13	R	-
14	B	-

Connector No.	M175
Connector Name	JOINT CONNECTOR-M22
Connector Color	WHITE

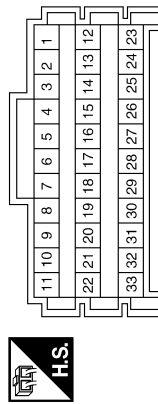

Terminal No.	Color of Wire	Signal Name
12	R	-
13	R	-
14	R	-
15	B	-
16	B	-
17	B	-

Connector No.	M181
Connector Name	JOINT CONNECTOR-M36
Connector Color	WHITE

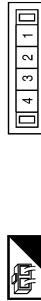

Terminal No.	Color of Wire	Signal Name
1	W	-
2	W	-

Connector No.	M185
Connector Name	AUTOMATIC BACK DOOR MAIN SWITCH
Connector Color	WHITE

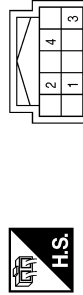

Terminal No.	Color of Wire	Signal Name
2	B	-
4	R	-

ILLUMINATION

< WIRING DIAGRAM >

Connector No.	M201
Connector Name	WIRE TO WIRE
Connector Color	WHITE

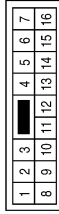

Terminal No.	Color of Wire	Signal Name
9	B	-
11	R	-

Connector No.	M192
Connector Name	DISPLAY UNIT (WITH BASE AUDIO SYSTEM)
Connector Color	WHITE

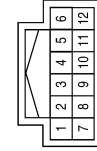

Terminal No.	Color of Wire	Signal Name
10	R	ILL+
11	B	ILL-

Connector No.	M186
Connector Name	AUTOMATIC BACK DOOR SWITCH
Connector Color	GREEN

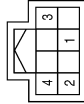

Terminal No.	Color of Wire	Signal Name
3	R	-
4	B	-

Connector No.	M204
Connector Name	CVT SHIFT SELECTOR INDICATOR LAMP
Connector Color	BROWN



Terminal No.	Color of Wire	Signal Name
1	R	-
2	B	-

Connector No.	M203
Connector Name	CLIMATE CONTROLLED SEAT SWITCH (DRIVER SEAT)
Connector Color	WHITE

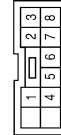

Terminal No.	Color of Wire	Signal Name
7	R	-
8	B	-

Connector No.	M202
Connector Name	WIRE TO WIRE
Connector Color	WHITE

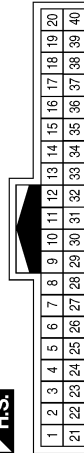

Terminal No.	Color of Wire	Signal Name
22	R	-
23	B	-

ABLIA5076GB

A
B
C
D
E
F
G
H
I
J
K
L
M
N
O
P

INL

ILLUMINATION

< WIRING DIAGRAM >

Connector No.	M214
Connector Name	WIRE TO WIRE
Connector Color	WHITE

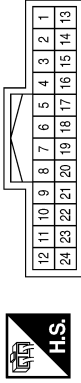

Terminal No.	Color of Wire	Signal Name
6	B	-
7	R	-

Connector No.	M212
Connector Name	4WD SHIFT SWITCH
Connector Color	BLACK



Terminal No.	Color of Wire	Signal Name
4	B	-
7	R	-

Connector No.	M206
Connector Name	CLIMATE CONTROLLED SEAT SWITCH (PASSENGER SEAT)
Connector Color	BROWN

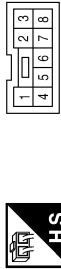

Terminal No.	Color of Wire	Signal Name
7	R	-
8	B	-

Connector No.	M251
Connector Name	WIRE TO WIRE
Connector Color	WHITE

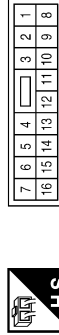

Terminal No.	Color of Wire	Signal Name
9	B	-
11	R	-

Connector No.	M221
Connector Name	FRONT HEATED SEAT SWITCH RH
Connector Color	BROWN



Terminal No.	Color of Wire	Signal Name
1	B	-
2	R	-

Connector No.	M220
Connector Name	FRONT HEATED SEAT SWITCH LH
Connector Color	WHITE



Terminal No.	Color of Wire	Signal Name
1	B	-
2	R	-

ABLIA5077GB

ILLUMINATION

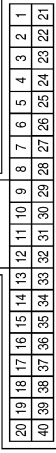

< WIRING DIAGRAM >

Connector No.	M257
Connector Name	WIRE TO WIRE
Connector Color	WHITE



Terminal No.	Color of Wire	Signal Name
22	R	-
23	B	-

Connector No.	M253
Connector Name	2ND ROW HEATED SEAT SWITCH RH
Connector Color	BROWN

Terminal No.	Color of Wire	Signal Name
5	R	-
6	B	-

Connector No.	M252
Connector Name	2ND ROW HEATED SEAT SWITCH LH
Connector Color	WHITE

Terminal No.	Color of Wire	Signal Name
5	R	-
6	B	-

Connector No.	E45
Connector Name	JOINT CONNECTOR-E12
Connector Color	BLUE



Terminal No.	Color of Wire	Signal Name
1	L	-
4	L	-
7	P	-
10	P	-

Connector No.	E28
Connector Name	FUSE BLOCK (J/B)
Connector Color	WHITE



Terminal No.	Color of Wire	Signal Name
6M	L	-

Connector No.	M258
Connector Name	REAR AIR CONTROL
Connector Color	WHITE



Terminal No.	Color of Wire	Signal Name
5	R	ILL (+)
6	B	ILL (-)

ABLIA5078GB

A
B
C
D
E
F
G
H
I
J
K
L
M
N
O
P

INL

ILLUMINATION

< WIRING DIAGRAM >

Connector No.	E70
Connector Name	JOINT CONNECTOR-E14
Connector Color	BLACK



Terminal No.	Color of Wire	Signal Name
1	P	-
2	P	-

Connector No.	E71
Connector Name	JOINT CONNECTOR-E15
Connector Color	BLACK



Terminal No.	Color of Wire	Signal Name
1	L	-
2	L	-

Connector No.	E119
Connector Name	IPDM E/R (INTELLIGENT POWER DISTRIBUTION MODULE ENGINE ROOM)
Connector Color	WHITE

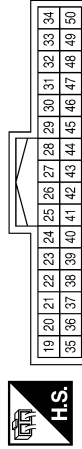

Terminal No.	Color of Wire	Signal Name
28	P	CAN-L
29	L	CAN-H
41	B	GND (SIGNAL)

Connector No.	E121
Connector Name	IPDM E/R (INTELLIGENT POWER DISTRIBUTION MODULE ENGINE ROOM)
Connector Color	WHITE

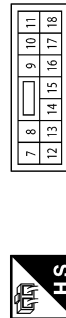

Terminal No.	Color of Wire	Signal Name
7	B	GND (POWER)
10	L	TAIL LH

Connector No.	E152
Connector Name	WIRE TO WIRE
Connector Color	WHITE

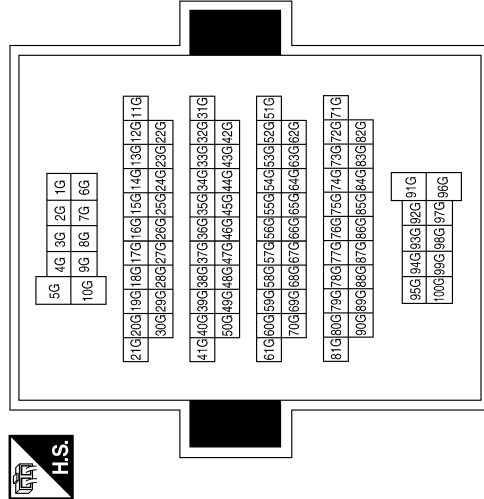

Terminal No.	Color of Wire	Signal Name
10G	P	-
35G	P	-
36G	L	-

ILLUMINATION

< WIRING DIAGRAM >

Connector No.	B11
Connector Name	JOINT CONNECTOR-B09
Connector Color	WHITE



Terminal No.	Color of Wire	Signal Name
1	P	-
2	P	-

Connector No.	B12
Connector Name	JOINT CONNECTOR-B10
Connector Color	WHITE



Terminal No.	Color of Wire	Signal Name
1	L	-
2	L	-

Connector No.	B16
Connector Name	JOINT CONNECTOR-B11
Connector Color	WHITE



Terminal No.	Color of Wire	Signal Name
1	P	-
2	P	-

Connector No.	B17
Connector Name	JOINT CONNECTOR-B12
Connector Color	WHITE



Terminal No.	Color of Wire	Signal Name
1	L	-
2	L	-

Connector No.	B32
Connector Name	WIRE TO WIRE
Connector Color	WHITE

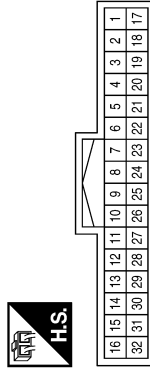

Terminal No.	Color of Wire	Signal Name
18	L	-
19	P	-

Connector No.	B69
Connector Name	WIRE TO WIRE
Connector Color	GRAY

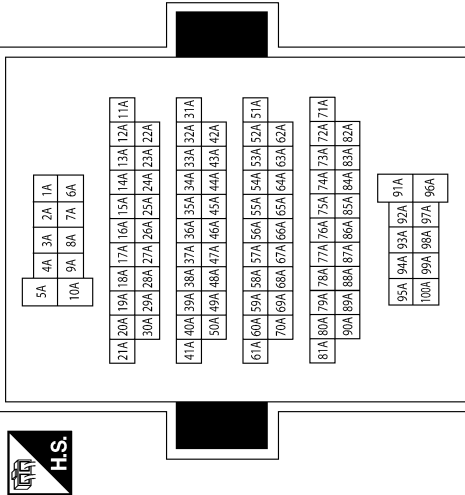

Terminal No.	Color of Wire	Signal Name
89A	L	-
90A	P	-

AALIA0965GB

A B C D E F G H I J K M N O P



ILLUMINATION

< WIRING DIAGRAM >

Connector No.	R1
Connector Name	WIRE TO WIRE
Connector Color	WHITE

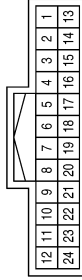

Terminal No.	Color of Wire	Signal Name
3	W	-
24	B	-

Connector No.	B124
Connector Name	WIRE TO WIRE
Connector Color	WHITE

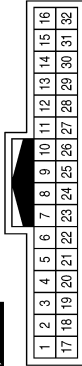

Terminal No.	Color of Wire	Signal Name
18	L	-
19	P	-

Connector No.	B101
Connector Name	WIRE TO WIRE
Connector Color	WHITE

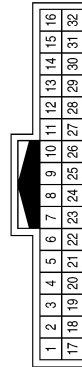

Terminal No.	Color of Wire	Signal Name
17	L	-
18	P	-

Connector No.	R107
Connector Name	FRONT ROOM/MAP LAMP ASSEMBLY
Connector Color	WHITE

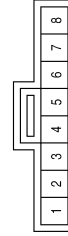

Terminal No.	Color of Wire	Signal Name
7	B	-
8	W	-

Connector No.	R101
Connector Name	WIRE TO WIRE
Connector Color	WHITE

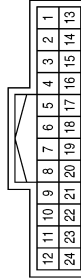

Terminal No.	Color of Wire	Signal Name
9	B	-
10	W	-

Connector No.	R11
Connector Name	WIRE TO WIRE
Connector Color	WHITE

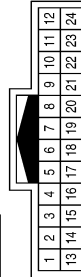

Terminal No.	Color of Wire	Signal Name
9	B	-
10	W	-

ABLIA5080GB

ILLUMINATION

< WIRING DIAGRAM >

Connector No.	D27
Connector Name	DOOR MIRROR REMOTE CONTROL SWITCH (WITHOUT AUTOMATIC DRIVE POSITIONER)
Connector Color	BLACK

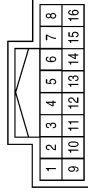

Terminal No.	Color of Wire	Signal Name
13	V	-
14	BR	-

Connector No.	D22
Connector Name	DOOR MIRROR REMOTE CONTROL SWITCH (WITH AUTOMATIC DRIVE POSITIONER)
Connector Color	GRAY

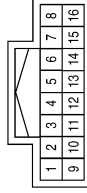

Terminal No.	Color of Wire	Signal Name
13	V	-
14	BR	-

Connector No.	D3
Connector Name	WIRE TO WIRE
Connector Color	WHITE

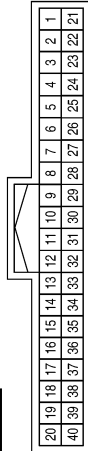

Terminal No.	Color of Wire	Signal Name
13	V	-
14	BR	-

A
B
C
D
E
F
G
H
I
J
K
INL
M
N
O
P

ABLIA5081GB

DIAGNOSIS AND REPAIR WORKFLOW

< BASIC INSPECTION >

BASIC INSPECTION

DIAGNOSIS AND REPAIR WORKFLOW

Work Flow

INFOID:000000009175438

OVERALL SEQUENCE

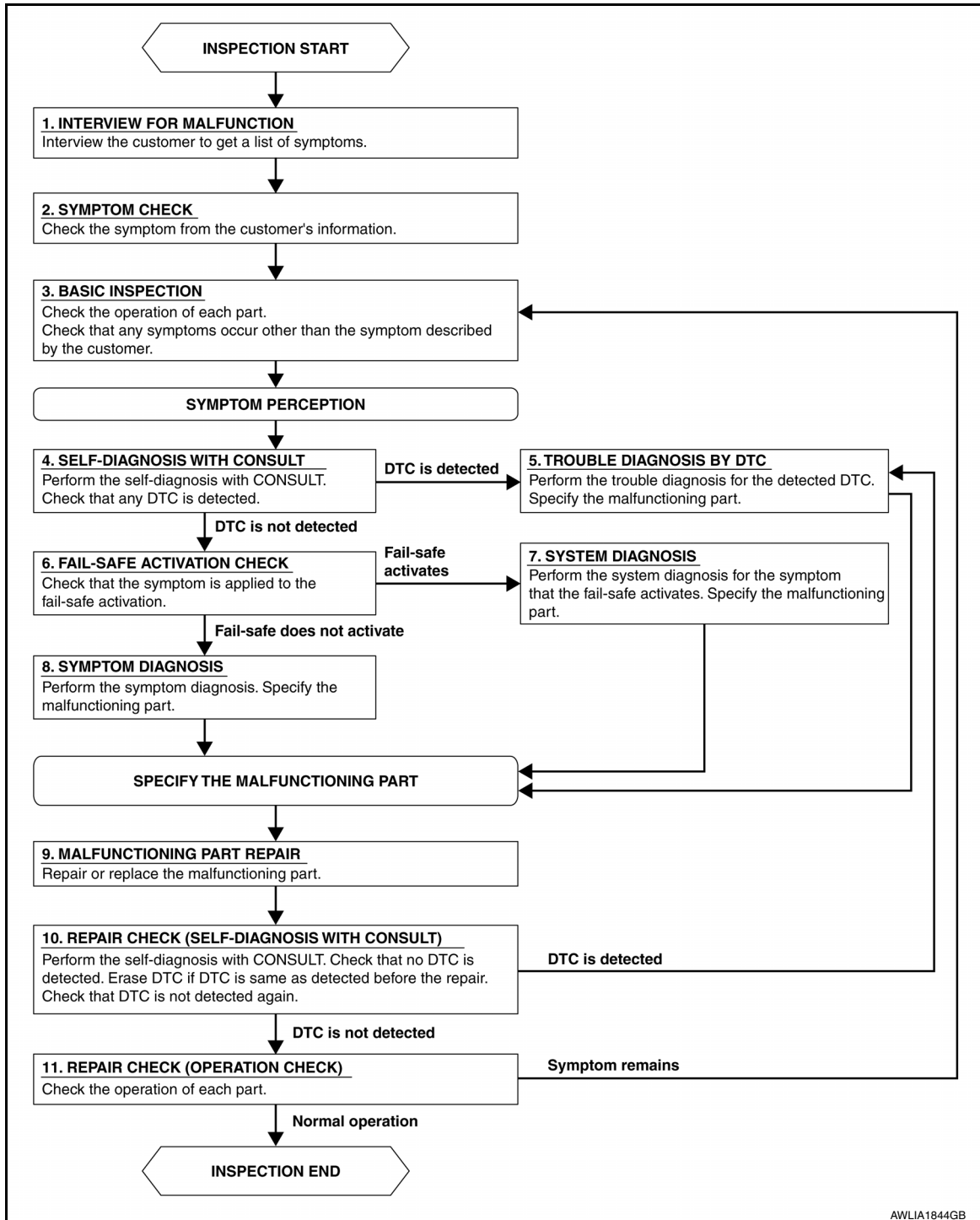

AWLIA1844GB

DIAGNOSIS AND REPAIR WORKFLOW

< BASIC INSPECTION >

DETAILED FLOW

1. INTERVIEW FOR MALFUNCTION

Find out what the customer's concerns are.

>> GO TO 2.

2. SYMPTOM CHECK

Verify the symptom from the customer's information.

>> GO TO 3.

3. BASIC INSPECTION

Check the operation of each part. Check that any concerns occur other than those mentioned in the customer interview.

>> GO TO 4.

4. SELF-DIAGNOSIS WITH CONSULT

Perform the self-diagnosis with CONSULT. Check that any DTC is detected.

Is any DTC detected?

YES >> GO TO 5.

NO >> GO TO 6.

5. TROUBLE DIAGNOSIS BY DTC

Perform the trouble diagnosis for the detected DTC. Specify the malfunctioning part.

>> GO TO 9.

6. FAIL-SAFE ACTIVATION CHECK

Determine if the customer's concern is related to fail-safe activation.

Does the fail-safe activate?

YES >> GO TO 7.

NO >> GO TO 8.

7. SYSTEM DIAGNOSIS

Perform the system diagnosis for the system in which the fail-safe activates. Specify the malfunctioning part.

>> GO TO 9.

8. SYMPTOM DIAGNOSIS

Perform the symptom diagnosis, refer to [INL-57, "Symptom Table"](#). Specify the malfunctioning part.

>> GO TO 9.

9. MALFUNCTION PART REPAIR

Repair or replace the malfunctioning part.

>> GO TO 10.

10. REPAIR CHECK (SELF-DIAGNOSIS WITH CONSULT)

Perform the self-diagnosis with CONSULT. Verify that no DTCs are detected. Erase all DTCs detected prior to the repair. Verify that DTC is not detected again.

Is any DTC detected?

YES >> GO TO 5.

A

B

C

D

E

F

G

H

I

J

K

INL

M

N

O

P

DIAGNOSIS AND REPAIR WORKFLOW

< BASIC INSPECTION >

NO >> GO TO 11.

11.REPAIR CHECK (OPERATION CHECK)

Check the operation of each part.

Does it operate normally?

YES >> Inspection End.

NO >> GO TO 3.

POWER SUPPLY AND GROUND CIRCUIT

< DTC/CIRCUIT DIAGNOSIS >

DTC/CIRCUIT DIAGNOSIS

POWER SUPPLY AND GROUND CIRCUIT

BCM

BCM : Diagnosis Procedure

INFOID:000000009764027

Regarding Wiring Diagram information, refer to [BCS-55, "Wiring Diagram"](#).

1. CHECK FUSE AND FUSIBLE LINK

Check that the following fuse and fusible link are not blown.

Terminal No.	Signal name	Fuse and fusible link No.
139	Fusible link battery power	O (40A)
131	BCM battery fuse	1 (10A)

Is the fuse or fusible link blown?

- YES >> Replace the blown fuse or fusible link after repairing the affected circuit.
NO >> GO TO 2

2. CHECK POWER SUPPLY CIRCUIT

1. Disconnect BCM connector M81.
2. Check voltage between BCM connector M81 terminals 131, 139 and ground.

BCM		Ground	Voltage (Approx.)
Connector	Terminal		
M81	131	—	Battery voltage
	139		

Is the inspection result normal?

- YES >> GO TO 3
NO >> Repair or replace harness or connectors.

3. CHECK GROUND CIRCUIT

Check continuity between BCM connector M81 terminals 134, 143 and ground.

BCM		Ground	Continuity
Connector	Terminal		
M81	134	—	Yes
	143		

Is the inspection result normal?

- YES >> Inspection End.
NO >> Repair or replace harness or connectors.

IPDM E/R (INTELLIGENT POWER DISTRIBUTION MODULE ENGINE ROOM)

IPDM E/R (INTELLIGENT POWER DISTRIBUTION MODULE ENGINE ROOM) : Diagnosis Procedure

INFOID:000000009764028

Regarding Wiring Diagram information, refer to [PCS-21, "Wiring Diagram"](#).

POWER SUPPLY AND GROUND CIRCUIT

< DTC/CIRCUIT DIAGNOSIS >

1. CHECK FUSIBLE LINKS

Check that the following fusible links are not blown.

Terminal No.	Signal name	Fusible link No.
1	Fusible link main	E (80A)
2	Fusible link IPDM E/R	A (250A), C (80A)
3	Fusible link ignition switch	A (250A), B (100A), K (40A)

Is the fusible link blown?

YES >> Replace the blown fusible link after repairing the affected circuit.

NO >> GO TO 2

2. CHECK POWER SUPPLY CIRCUIT

1. Disconnect IPDM E/R connectors E118 and E120.
2. Check voltage between IPDM E/R connectors and ground.

IPDM E/R		Ground	Voltage (Approx.)
Connector	Terminal		
E118	1	—	Battery voltage
	2		
E120	3		

Is the inspection result normal?

YES >> GO TO 3

NO >> Repair or replace harness or connectors.

3. CHECK GROUND CIRCUIT

1. Disconnect IPDM E/R connectors E119 and E121.
2. Check continuity between IPDM E/R connectors and ground.

IPDM E/R		Ground	Continuity
Connector	Terminal		
E121	7	—	Yes
E119	41		

Is the inspection result normal?

YES >> Inspection End.

NO >> Repair or replace harness or connectors.

BATTERY SAVER OUTPUT/POWER SUPPLY CIRCUIT

< DTC/CIRCUIT DIAGNOSIS >

BATTERY SAVER OUTPUT/POWER SUPPLY CIRCUIT

Description

INFOID:000000009175440

Provides the battery saver output/power supply. Also cuts the power supply when the interior room lamp battery saver is activating.

Component Function Check

INFOID:000000009175441

1. CHECK BATTERY SAVER OUTPUT/POWER SUPPLY FUNCTION

CONSULT

1. Turn ignition switch ON.
2. Turn each interior room lamp ON:
 - Front room/map lamp assembly
 - Vanity lamps (if equipped)
 - Personal lamps 2nd row
 - Cargo lamp
3. Open the driver door to turn ON the following lamps:
 - Front step lamps (if equipped)
 - Foot lamps (if equipped)
4. Select BATTERY SAVER of BCM(BATTERY SAVER) active test item.
5. While operating the test item, check that each interior room lamp turns ON/OFF.

OFF : Interior room lamp OFF

ON : Interior room lamp ON

Is the inspection result normal?

YES >> Battery saver output/power supply circuit is normal.

NO >> Refer to [INL-49, "Diagnosis Procedure"](#).

Diagnosis Procedure

INFOID:000000009175442

Regarding Wiring Diagram information, refer to [INL-12, "Wiring Diagram"](#).

1. CHECK BATTERY SAVER OUTPUT/POWER SUPPLY OUTPUT

CONSULT

1. Turn ignition switch ON.
2. Select BATTERY SAVER of BCM(BATTERY SAVER) active test item.
3. While operating the test item, check voltage between BCM connector M81 terminal 129 and ground.

(+)		(-)	Test item	Voltage (Approx.)
Connector	Terminal		BATTERY SAVER	
M81	129	Ground	OFF	0V
			ON	Battery voltage

Is the inspection result normal?

YES >> GO TO 2.

NO >> Replace BCM after making sure battery saver output/power supply circuit is not shorted to voltage. Refer to [BCS-80, "Removal and Installation"](#).

2. CHECK BATTERY SAVER OUTPUT/POWER SUPPLY OPEN CIRCUIT

1. Turn ignition switch OFF.
2. Disconnect the following connectors:
 - BCM M81
 - Front step lamp LH D11(if equipped)
 - Front step lamp RH D109 (if equipped)

BATTERY SAVER OUTPUT/POWER SUPPLY CIRCUIT

< DTC/CIRCUIT DIAGNOSIS >

- Foot lamp LH M99 (if equipped)
 - Foot lamp RH M100 (if equipped)
 - Front room/map lamp assembly R107
 - Vanity lamp LH R103 (if equipped)
 - Vanity lamp RH R102 (if equipped)
 - Cargo lamp R104
 - Personal lamps 2nd row R106
3. Check continuity between BCM connector M81 terminal 129 and interior room lamp connector terminal in question.

BCM		Each interior room lamp			Continuity
Connector	Terminal	Connector		Terminal	
M81	129	Front step lamp LH (if equipped)	D11	1	Yes
		Front step lamp RH (if equipped)	D109	1	
		Foot lamp LH (if equipped)	M99	1	
		Foot lamp RH (if equipped)	M100	1	
		Front room/map lamp assembly	R107	1	
		Vanity lamp LH (if equipped)	R103	1	
		Vanity lamp RH (if equipped)	R102	1	
		Cargo lamp	R104	2	
		Personal lamps 2nd row	R106	2	

Is the inspection result normal?

YES >> GO TO 3.

NO >> Repair or replace harness or connector.

3. CHECK BATTERY SAVER OUTPUT/POWER SUPPLY SHORT CIRCUIT

Check continuity between BCM connector M81 terminal 129 and ground.

Connector	Terminal	—	Continuity
M81	129	Ground	No

Is the inspection result normal?

YES >> Check that each interior room lamp has no internal short circuit.

NO >> Repair or replace harness or connector.

INTERIOR ROOM LAMP CONTROL CIRCUIT

< DTC/CIRCUIT DIAGNOSIS >

INTERIOR ROOM LAMP CONTROL CIRCUIT

Description

INFOID:000000009175443

Controls the room lamp control circuit (ground side) to turn the room lamps ON and OFF.

Component Function Check

INFOID:000000009175444

CAUTION:

Before performing the diagnosis, check that the following are normal.

- Battery saver output/power supply
- Front room/map lamp bulb
- Personal lamp 2nd row bulb
- Cargo lamp bulb

1. CHECK INTERIOR ROOM LAMP CONTROL FUNCTION

CONSULT

1. Set the front room/map lamp switch, personal lamp switch and cargo lamp switch to DOOR.
2. Turn ignition switch ON.
3. Select INT LAMP of BCM(INT LAMP) active test item.
4. While operating the test item, check that each interior room lamp turn ON/OFF.

On : Interior room lamp On

Off : Interior room lamp Off

Does the interior room lamp turn ON/OFF?

YES >> Interior room lamp control circuit is normal.

NO >> Refer to [INL-51, "Diagnosis Procedure"](#).

Diagnosis Procedure

INFOID:000000009175445

Regarding Wiring Diagram information, refer to [INL-12, "Wiring Diagram"](#).

1. CHECK INTERIOR ROOM LAMP CONTROL OUTPUT

CONSULT

1. Turn ignition switch ON.
2. Select INT LAMP of BCM(INT LAMP) active test item.
3. While operating the test item, check voltage between BCM harness connector M81 terminal 136 and ground.

BCM		Ground	Test item		Voltage (Approx.)
Connector	Terminal		INT LAMP	On	
M81	136			On	0V
				Off	Battery voltage

Is the inspection result normal?

YES >> Interior room lamp control circuit is operating normally.

Fixed ON>>GO TO 3.

Fixed OFF>>GO TO 2.

2. CHECK INTERIOR ROOM LAMP CONTROL OPEN CIRCUIT

1. Turn ignition switch OFF.
2. Disconnect BCM harness connector M81, front room/map lamp harness connector R107 and cargo lamp harness connector R104.
3. Check continuity between BCM harness connector M81 terminal 136 and front room/map lamp assembly harness connector R107 terminal 3 and cargo lamp harness connector R104 terminal 3.

INTERIOR ROOM LAMP CONTROL CIRCUIT

< DTC/CIRCUIT DIAGNOSIS >

BCM		Interior room lamp			Continuity
Connector	Terminal	Connector	Terminal	Terminal	
M81	136	Front room/map lamp	R107	3	Yes
		Cargo lamp	R104	3	

4. Reconnect the front room/map lamp assembly harness connector.
5. Check continuity between BCM harness connector M81 terminal 136 and personal lamps 2nd row harness connector R106 terminal 3.

BCM		Personal lamp		Continuity
Connector	Terminal	Connector	Terminal	
M81	136	R106	3	Yes

Is the inspection result normal?

YES >> Check interior room lamps for an open. If NG, replace lamp in question. Refer to [INL-58, "Removal and Installation"](#) (front room/map lamp assembly) or [INL-65, "Removal and Installation"](#) (personal lamps 2nd row) or [INL-66, "Removal and Installation"](#) (cargo lamp). If OK, replace BCM. Refer to [BCS-80, "Removal and Installation"](#).

NO >> Repair or replace harness or connector.

3. CHECK INTERIOR ROOM LAMP CONTROL SHORT CIRCUIT

1. Turn ignition switch OFF.
2. Disconnect BCM harness connector M81, front room/map lamp harness connector R107 and cargo lamp harness connector R104.
3. Check continuity between BCM harness connector M81 terminal 136 and ground.

BCM		Ground	Continuity
Connector	Terminal		
M81	136		No

Is the inspection result normal?

YES >> Check interior room lamps for an open. If NG, replace lamp in question. Refer to [INL-58, "Removal and Installation"](#) (front room/map lamp assembly) or [INL-65, "Removal and Installation"](#) (personal lamps 2nd row) or [INL-66, "Removal and Installation"](#) (cargo lamp). If OK, replace BCM. Refer to [BCS-80, "Removal and Installation"](#).

NO >> Repair or replace harness or connector.

STEP LAMP CIRCUIT

< DTC/CIRCUIT DIAGNOSIS >

STEP LAMP CIRCUIT

Description

INFOID:000000009175446

Controls the step lamp control circuit (ground side) to turn the step lamps (if equipped) and foot lamps (if equipped) ON and OFF.

Component Function Check

INFOID:000000009175447

CAUTION:

Before performing the diagnosis, check that the following is normal.

- Battery saver output/power supply
- Front step lamp bulb (if equipped)
- Foot lamp bulb (if equipped)

1. CHECK STEP LAMP OPERATION

CONSULT

1. Turn ignition switch ON.
2. Select STEP LAMP TEST of BCM(INT LAMP) active test item.
3. While operating the test items, check that front step lamp (if equipped) and foot lamp (if equipped) turns ON/OFF.

On : Step lamp and foot lamp ON

Off : Step lamp and foot lamp OFF

Is the inspection result normal?

- YES >> Step lamp circuit is normal.
 NO >> Refer to [INL-53, "Diagnosis Procedure"](#).

Diagnosis Procedure

INFOID:000000009175448

Regarding Wiring Diagram information, refer to [INL-12, "Wiring Diagram"](#).

1. CHECK STEP LAMP OUTPUT

CONSULT

1. Turn ignition switch ON.
2. Select STEP LAMP TEST of BCM (INT LAMP) active test item.
3. While operating the test item, check voltage between BCM harness connector M18 terminal 21 and ground.

BCM		Ground	STEP LAMP TEST	Voltage (Approx.)
Connector	Terminal			
M18	21		On	0V
			Off	Battery voltage

Is the inspection result normal?

- YES >> Step lamp control circuit is operating normally.
 Fixed ON>>GO TO 3.
 Fixed OFF>>GO TO 2.

2. CHECK STEP LAMP OPEN CIRCUIT

1. Turn ignition switch OFF.
2. Disconnect the following harness connectors:
 - BCM M18
 - Front step lamp LH D11(if equipped)
 - Front step lamp RH D109 (if equipped)
 - Foot lamp LH M99 (if equipped)
 - Foot lamp RH M100 (if equipped)

A
B
C
D
E
F
G
H
I
J
K
M
N
O
P

INL

STEP LAMP CIRCUIT

< DTC/CIRCUIT DIAGNOSIS >

3. Check continuity between BCM harness connector M18 terminal 21 and the following lamp harness connector terminal.

BCM		Step lamp		Continuity
Connector	Terminal	Connector	Terminal	
M18	21	Front step lamp LH (if equipped)	D11	2 Yes
		Front step lamp RH (if equipped)	D109	
		Foot lamp LH (if equipped)	M99	
		Foot lamp RH (if equipped)	M100	

Is the inspection result normal?

YES >> Check front step lamp (if equipped) or foot lamp (if equipped) for an open. If NG, replace lamp in question. Refer to [INL-64. "Removal and Installation"](#) (step lamp) (if equipped) or [INL-62. "DRIVER SIDE : Removal and Installation"](#) (foot lamp) (if equipped). If OK, replace BCM. Refer to [BCS-80. "Removal and Installation"](#).

NO >> Repair or replace harness or connector.

3.CHECK STEP LAMP SHORT CIRCUIT

1. Turn ignition switch OFF.
2. Disconnect the following harness connectors:
 - BCM M18
 - Front step lamp LH D11(if equipped)
 - Front step lamp RH D109 (if equipped)
 - Foot lamp LH M99 (if equipped)
 - Foot lamp RH M100 (if equipped)
3. Check continuity between BCM harness connector M18 terminal 21 and ground.

BCM		Ground	Continuity
Connector	Terminal		
M18	21		No

Is the inspection result normal?

YES >> Replace BCM. Refer to [BCS-80. "Removal and Installation"](#).

NO >> Repair or replace harness or connector.

PUSH-BUTTON IGNITION SWITCH ILLUMINATION CIRCUIT

< DTC/CIRCUIT DIAGNOSIS >

PUSH-BUTTON IGNITION SWITCH ILLUMINATION CIRCUIT

Description

INFOID:000000009175449

Provides the power supply and the ground to control the push-button ignition switch illumination.

Component Function Check

INFOID:000000009175450

1. CHECK PUSH-BUTTON IGNITION SWITCH ILLUMINATION OPERATION

CONSULT

1. Turn the ignition switch ON.
2. Select ENGINE SW ILLUMI of BCM (INTELLIGENT KEY) active test item.
3. While operating the test items, check that the push-button ignition switch illumination turns ON/OFF.

On : Push-button ignition switch illumination ON

Off : Push-button ignition switch illumination OFF

Does the push-button ignition switch illumination turn ON/OFF?

- YES >> Push-button ignition switch illumination circuit is normal.
NO >> Refer to [INL-55, "Diagnosis Procedure"](#).

Diagnosis Procedure

INFOID:000000009175451

Regarding Wiring Diagram information, refer to [INL-26, "Wiring Diagram"](#).

1. CHECK PUSH-BUTTON IGNITION SWITCH ILLUMINATION OPERATION

CONSULT

1. Turn the ignition switch ON.
2. Select ENGINE SW ILLUMI of BCM (INTELLIGENT KEY) active test item.
3. While operating the test item, check voltage between push-button ignition switch connector M17 terminal 5 and ground.

Terminals		Test item	Voltage (Approx.)
(+)	(-)		
Push-button ignition switch		ENGINE SW ILLUMI	5 V
Connector	Terminal		
M17	5	ON	5 V
		OFF	0 V

Is the inspection result normal?

- YES >> GO TO 4.
NO >> GO TO 2.

2. CHECK PUSH-BUTTON IGNITION SWITCH ILLUMINATION POWER SUPPLY OPEN CIRCUIT

1. Turn the ignition switch OFF.
2. Disconnect BCM harness connector M19 and the push-button ignition switch harness connector M17.
3. Check continuity between BCM harness connector M19 terminal 48 and the push-button ignition switch harness connector M17 terminal 5.

BCM		Push-button ignition switch		Continuity
Connector	Terminal	Connector	Terminal	
M19	48	M17	5	Yes

Is the inspection result normal?

- YES >> GO TO 3.

PUSH-BUTTON IGNITION SWITCH ILLUMINATION CIRCUIT

< DTC/CIRCUIT DIAGNOSIS >

NO >> Repair or replace harness or connector.

3. CHECK PUSH-BUTTON IGNITION SWITCH ILLUMINATION POWER SUPPLY SHORT CIRCUIT

Check continuity between BCM harness connector M19 terminal 48 and ground.

BCM		Ground	Continuity
Connector	Terminal		
M19	48		No

Is the inspection result normal?

YES >> Replace BCM. Refer to [BCS-80. "Removal and Installation"](#).

NO >> Repair or replace harness or connector.

4. CHECK PUSH-BUTTON IGNITION SWITCH ILLUMINATION GROUND CIRCUIT

1. Turn the ignition switch OFF.
2. Disconnect push-button ignition switch harness connector M17.
3. Check continuity between push-button ignition switch harness connector M17 terminal 6 and ground.

Push-button ignition switch		Ground	Continuity
Connector	Terminal		
M17	6		Yes

Is the inspection result normal?

YES >> Replace push-button ignition switch. Refer to [SEC-145. "Removal and Installation"](#).

NO >> GO TO 5.

5. CHECK PUSH-BUTTON IGNITION SWITCH ILLUMINATION GROUND OPEN CIRCUIT

1. Disconnect BCM harness connector M80.
2. Check continuity between BCM harness connector M80 terminal 107 and push-button ignition switch harness connector M17 terminal 6.

Push-button ignition switch		BCM		Continuity
Connector	Terminal	Connector	Terminal	
M17	6	M80	107	Yes

Is the inspection result normal?

YES >> Replace BCM. Refer to [BCS-80. "Removal and Installation"](#).

NO >> Repair or replace harness or connectors.

INTERIOR LIGHTING SYSTEM SYMPTOMS

< SYMPTOM DIAGNOSIS >

SYMPTOM DIAGNOSIS

INTERIOR LIGHTING SYSTEM SYMPTOMS

Symptom Table

INFOID:000000009175452

CAUTION:

Perform the self-diagnosis with CONSULT before the symptom diagnosis. Perform the trouble diagnosis if any DTC is detected.

Symptom	Possible cause	Inspection item
All the following lamps do not turn ON: <ul style="list-style-type: none"> • Front room/map lamp • Personal lamp 2nd row • Foot lamp LH/RH (if equipped) • Step lamp LH/RH (if equipped) • Cargo lamp • Vanity lamp LH/RH (if equipped) 	<ul style="list-style-type: none"> • Harness between BCM and each interior room lamp • BCM 	Battery saver output/power supply circuit Refer to INL-49 .
<ul style="list-style-type: none"> • Interior room lamp does not turn ON even though the door is open. (It turns ON when turning the interior room lamp ON.) • Interior room lamp does not turn OFF even though the door is closed. 	<ul style="list-style-type: none"> • Harness between BCM and each door switch • Harness between BCM and each interior room lamp • BCM 	Door switch circuit Refer to DLK-170 . <hr/> Interior room lamp control circuit Refer to INL-51 .
Interior room lamp timer does not activate. (It turns ON/ OFF when the door opens/closes.)	—	Check the interior room lamp setting. Refer to BCS-17 .
<ul style="list-style-type: none"> • Step lamps (if equipped) and foot lamps (if equipped) do not turn ON even though the door is open. • Step lamps (if equipped) and foot lamps (if equipped) do not turn OFF even though the door is closed. 	<ul style="list-style-type: none"> • Harness between BCM and each step lamp (if equipped) or foot lamp (if equipped) • BCM 	Door switch circuit Refer to DLK-170 . <hr/> Step lamp circuit Refer to INL-53 .
Push-button ignition switch illumination does not illuminate.	<ul style="list-style-type: none"> • Harness between BCM and push-button ignition switch • BCM 	Push-button ignition switch illumination circuit Refer to INL-55 .
Interior room lamp battery saver does not activate.	BCM	Replace BCM. Refer to BCS-80 .

A
B
C
D
E
F
G
H
I
J
K
M
N
O
P

INL

FRONT ROOM/MAP LAMP ASSEMBLY

< REMOVAL AND INSTALLATION >

REMOVAL AND INSTALLATION

FRONT ROOM/MAP LAMP ASSEMBLY

Exploded View

INFOID:000000009723408

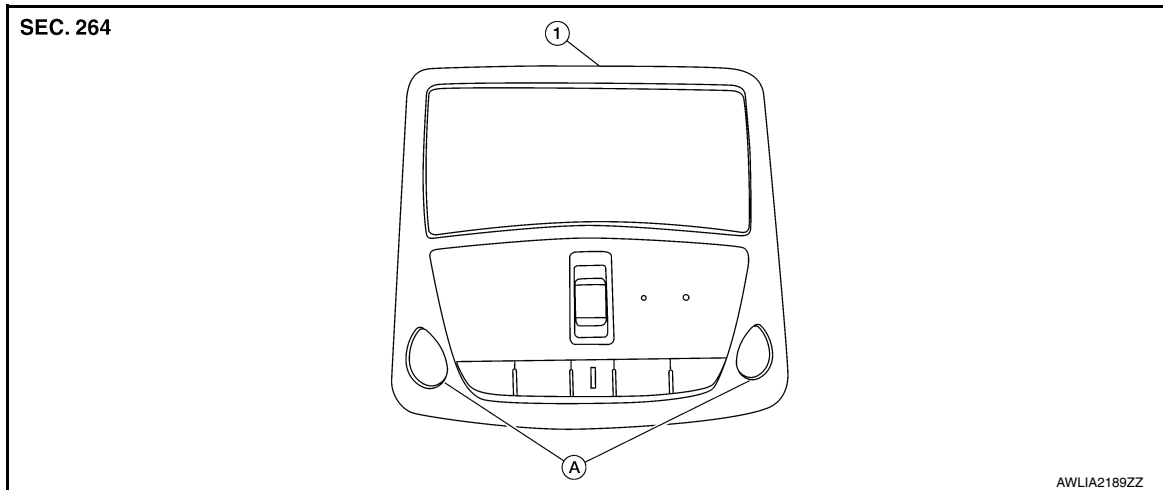

1. Front room/map lamp assembly A. LED

Removal and Installation

INFOID:000000009175453

CAUTION:

Do not attempt to separate the front room/map lamp assembly from the headlining prior to removing headlining, or damage to the components may occur.

REMOVAL

1. Remove the headlining. Refer to [INT-27, "Removal and Installation"](#).
2. Remove the bracket screws, then remove front room/map lamp assembly bracket (1) from front room/map assembly (3) and position aside.
3. Disconnect the harness connectors from front room/map lamp assembly (3).
4. Release the front room/map lamp assembly back plate (2) metal clips and remove from headlining.
5. Release the back plate pawls (A) using a suitable tool and remove the front room/map lamp assembly (3).

 Metal clip

 Pawl

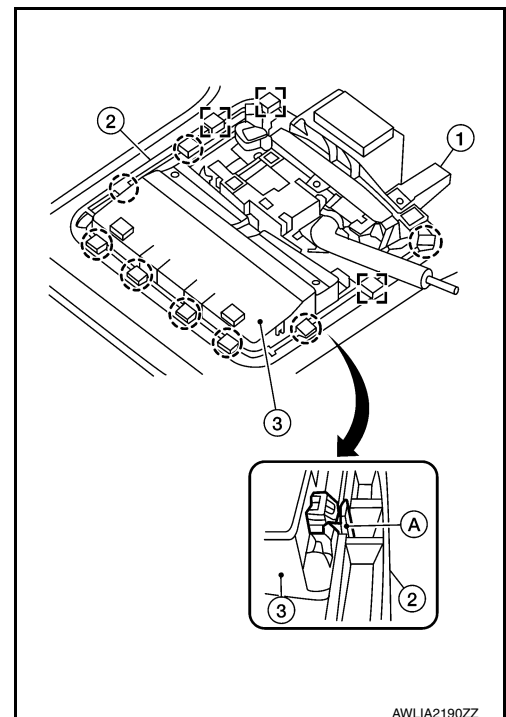

INSTALLATION

Installation is in the reverse order of removal.

CAUTION:

FRONT ROOM/MAP LAMP ASSEMBLY

< REMOVAL AND INSTALLATION >

Visually check the metal clips and pawls for deformation and damage during installation. Replace with new ones if necessary.

Bulb or Lens Replacement

INFOID:000000009723955

WARNING:

Do not touch the glass surface of a bulb while it is lit or right after being turned OFF to prevent burns.

CAUTION:

Do not attempt to separate the LED bulb from the front room/map lamp assembly or damage to the components may occur

The LED bulb is replaced as part of the front room/map lamp assembly. Refer to [INL-58. "Removal and Installation"](#)

A
B
C
D
E
F
G
H
I
J
K
INL
M
N
O
P

VANITY LAMP

< REMOVAL AND INSTALLATION >

VANITY LAMP

Exploded View

INFOID:000000009175455

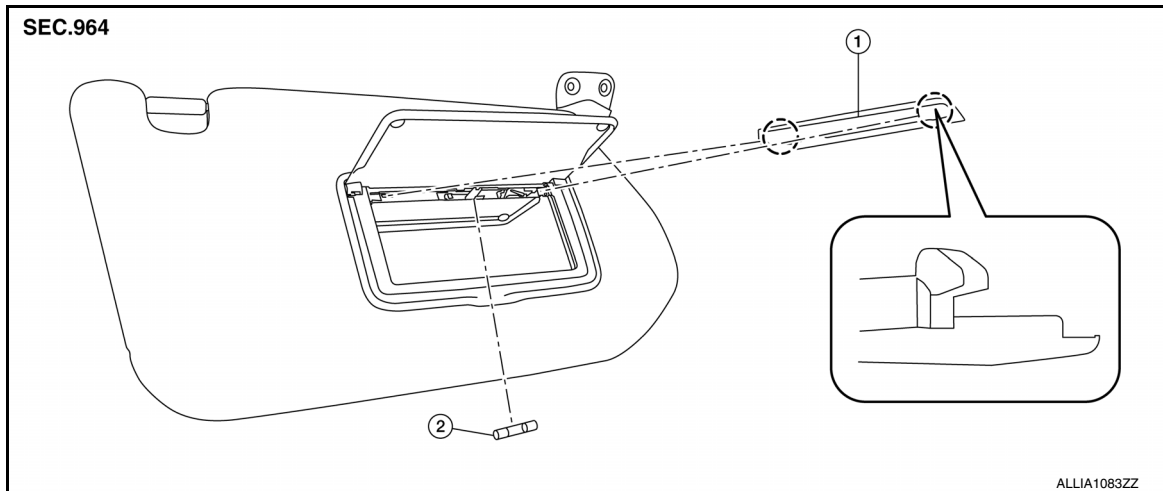

1. Lens

2. Bulb

3. Pawl

Removal and Installation

INFOID:000000009175456

CAUTION:

Do not attempt to separate the vanity lamp from the sun visor or damage to the components may occur.

The vanity lamp is replaced as part of the sun visor. Refer to [INT-27, "Removal and Installation"](#).

Bulb or Lens Replacement

INFOID:000000009175457

WARNING:

Do not touch the glass surface of a bulb while it is lit or right after being turned OFF to prevent burns.

CAUTION:

- Do not touch the glass of bulb directly by hand. Keep grease and other oily substances away from bulb surface.
- Do not leave bulb out of lamp reflector for a long time because dust, moisture, smoke, etc. may affect the performance of lamp.
- Do not attempt to separate the vanity lamp from the sun visor or damage to the components may occur.

1. Insert a suitable tool into the gap between the lens and vanity lamp, then gently release the lens pawls and remove.
2. Grasp the bulb and pull straight out of the vanity lamp to remove.
3. Install vanity lamp bulb to vanity lamp.
4. Install the vanity lamp lens.

GLOVE BOX LAMP

< REMOVAL AND INSTALLATION >

GLOVE BOX LAMP

Exploded View

INFOID:000000009175458

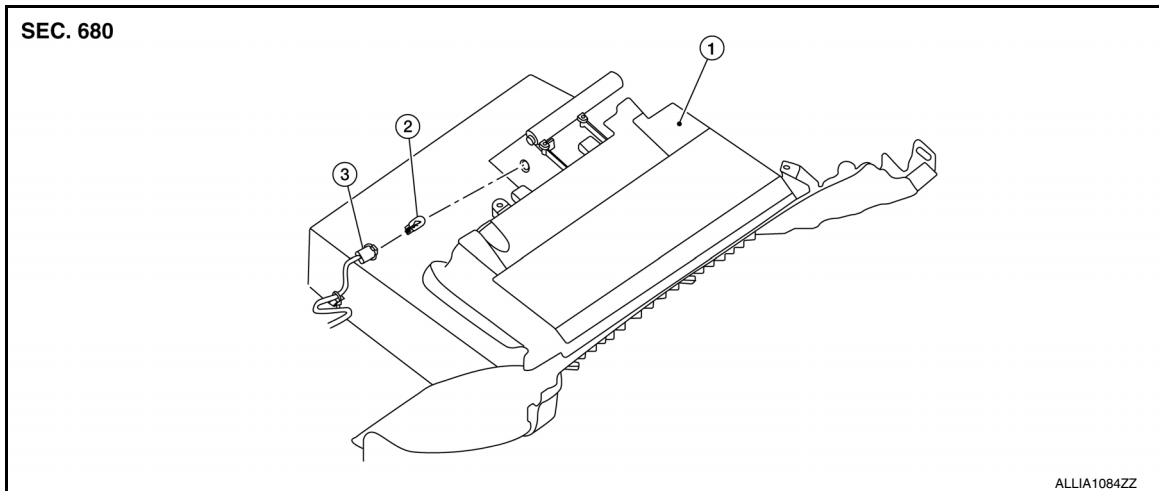

1. Glove box assembly

2. Bulb

3. Bulb socket

Bulb Replacement

INFOID:000000009175459

WARNING:

Do not touch the glass surface of a bulb while it is lit or right after being turned OFF to prevent burns.

CAUTION:

- **Do not touch the glass of bulb directly by hand. Keep grease and other oily substances away from bulb surface.**
- **Do not leave bulb out of lamp reflector for a long time because dust, moisture, smoke, etc. may affect the performance of lamp.**

1. Remove glove box. Refer to [IP-26, "Removal and Installation"](#).
2. Rotate the bulb socket counterclockwise and remove.
3. Grasp the bulb and pull straight out of the bulb socket to remove.
4. Install glove box lamp bulb to bulb socket.
5. Insert bulb socket into glove box and rotate clockwise to lock in position.
6. Install glove box. Refer to [IP-26, "Removal and Installation"](#).

A
B
C
D
E
F
G
H
I
J
K
INL
M
N
O
P

FOOT LAMP

< REMOVAL AND INSTALLATION >

FOOT LAMP DRIVER SIDE

DRIVER SIDE : Exploded View

INFOID:000000009175460

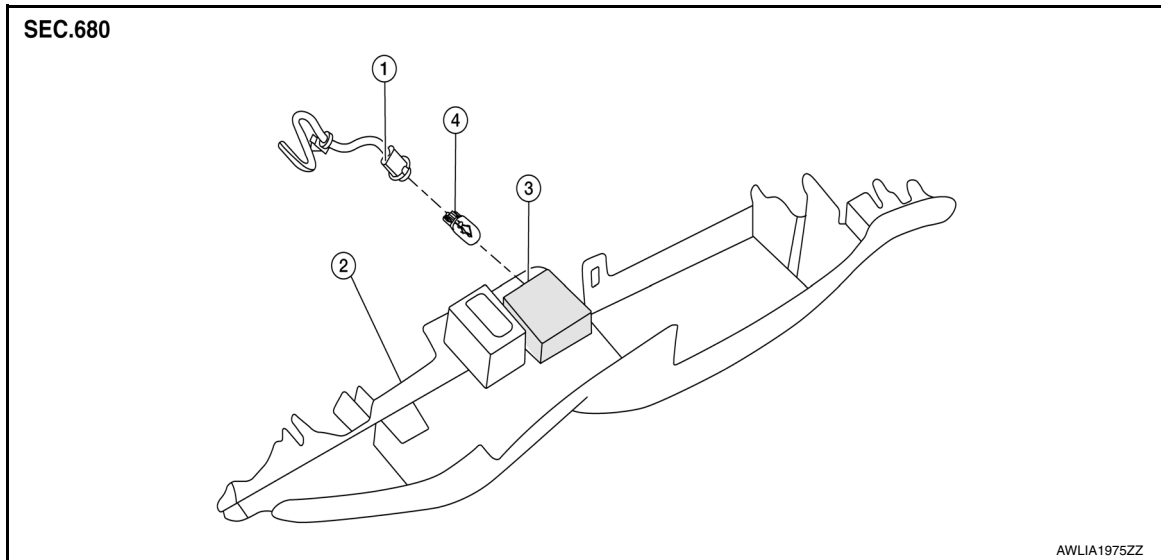

1. Bulb socket
2. Instrument lower panel LH
3. Foot lamp housing
4. Bulb

DRIVER SIDE : Removal and Installation

INFOID:000000009175461

The foot lamp housing is replaced as part of the instrument lower panel LH. Refer to [IP-25, "Removal and Installation"](#).

DRIVER SIDE : Bulb Replacement

INFOID:000000009175462

WARNING:

Do not touch the glass surface of a bulb while it is lit or right after being turned OFF to prevent burns.

CAUTION:

- Do not touch the glass of bulb directly by hand. Keep grease and other oily substances away from bulb surface.
- Do not leave bulb out of lamp reflector for a long time because dust, moisture, smoke, etc. may affect the performance of lamp.

1. Remove instrument lower panel LH. Refer to [IP-25, "Removal and Installation"](#).
2. Rotate the bulb socket counterclockwise and remove.
3. Grasp the bulb and pull straight out of the bulb socket to remove.
4. Install foot lamp bulb to bulb socket.
5. Insert bulb socket into foot lamp housing and rotate clockwise to lock in position.
6. Install the instrument lower panel LH. Refer to [IP-25, "Removal and Installation"](#).

PASSENGER SIDE

FOOT LAMP

< REMOVAL AND INSTALLATION >

PASSENGER SIDE : Exploded View

INFOID:000000009175463

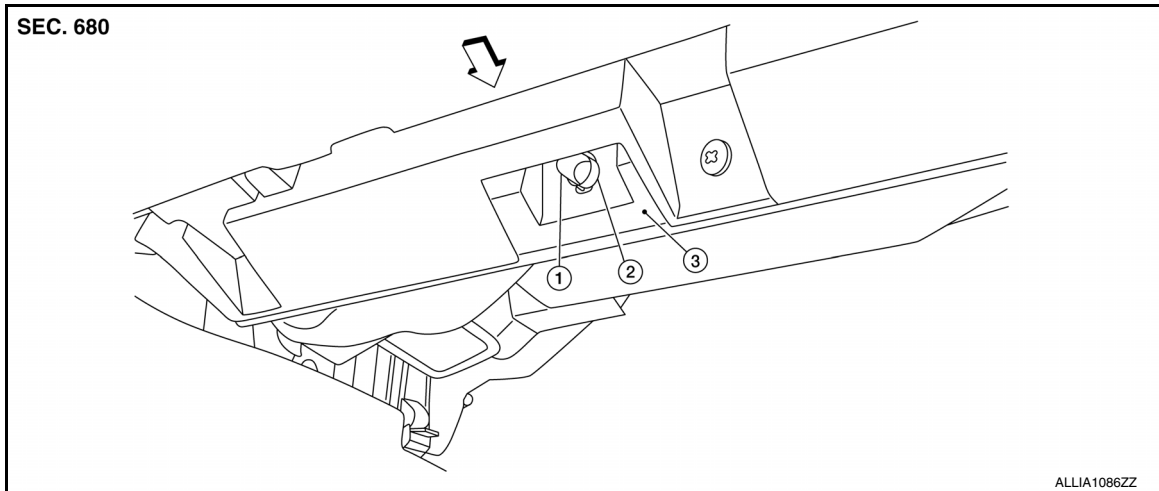

1. Bulb

2. Bulb socket

3. Instrument panel substrate

↩ Front

PASSENGER SIDE : Bulb Replacement

INFOID:000000009175464

WARNING:

Do not touch the glass surface of a bulb while it is lit or right after being turned OFF to prevent burns.

CAUTION:

- Do not touch the glass of bulb directly by hand. Keep grease and other oily substances away from bulb surface.
- Do not leave bulb out of lamp reflector for a long time because dust, moisture, smoke, etc. may affect the performance of lamp.

1. Reach under instrument panel on RH side, locate foot lamp socket, rotate the bulb socket and remove.
2. Grasp the bulb and pull straight out of the bulb socket to remove.
3. Install foot lamp bulb to bulb socket.
4. Insert bulb socket into instrument panel substrate and rotate to lock in position.

A

B

C

D

E

F

G

H

I

J

K

INL

M

N

O

P

FRONT STEP LAMP

< REMOVAL AND INSTALLATION >

FRONT STEP LAMP

Exploded View

INFOID:000000009175465

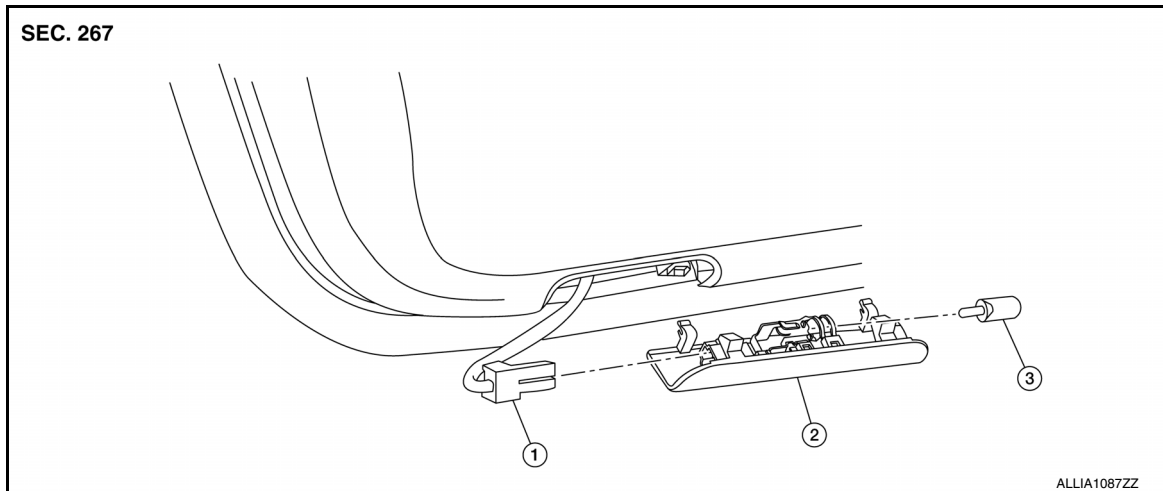

1. Step lamp harness connector

2. Step lamp

3. Bulb

Removal and Installation

INFOID:000000009175466

REMOVAL

1. Insert a suitable tool into the gap between the front step lamp and front door finisher and gently release the pawls and the front step lamp.
2. Disconnect the harness connector from the front step lamp and remove.

INSTALLATION

Installation is in the reverse order of removal.

Bulb or Lens Replacement

INFOID:000000009175467

WARNING:

Do not touch the glass surface of a bulb while it is lit or right after being turned OFF to prevent burns.

CAUTION:

- Do not touch the glass of bulb directly by hand. Keep grease and other oily substances away from bulb surface.
 - Do not leave bulb out of lamp reflector for a long time because dust, moisture, smoke, etc. may affect the performance of lamp.
1. Remove the front step lamp. Refer to [INL-64, "Removal and Installation"](#).
 2. Grasp the bulb and pull straight out from the front step lamp to remove.
 3. Install the front step lamp bulb to front step lamp.
 4. Install the front step lamp. Refer to [INL-64, "Removal and Installation"](#)

PERSONAL LAMP

< REMOVAL AND INSTALLATION >

PERSONAL LAMP

Removal and Installation

INFOID:000000009175469

REMOVAL

The personal lamp is serviced as part of headlining. Refer to [INT-27. "Removal and Installation"](#)

Bulb or Lens Replacement

INFOID:000000009175470

WARNING:

Do not touch the glass surface of a bulb while it is lit or right after being turned OFF to prevent burns.

CAUTION:

- **Do not touch the glass of bulb directly by hand. Keep grease and other oily substances away from bulb surface.**
 - **Do not leave bulb out of lamp reflector for a long time because dust, moisture, smoke, etc. may affect the performance of lamp.**
 - **Do not attempt to separate the personal lamp from the headlining or damage may occur.**
1. Insert a suitable tool into the gap between the lens and personal lamp, then gently release the lens pawls and remove.
 2. Grasp the bulb and pull straight out from its socket to remove.
 3. Install personal lamp bulb to personal lamp.
 4. Install the personal lamp lens.

A
B
C
D
E
F
G
H
I
J
K
M
N
O
P

INL

CARGO LAMP

< REMOVAL AND INSTALLATION >

CARGO LAMP

Exploded View

INFOID:000000009175471

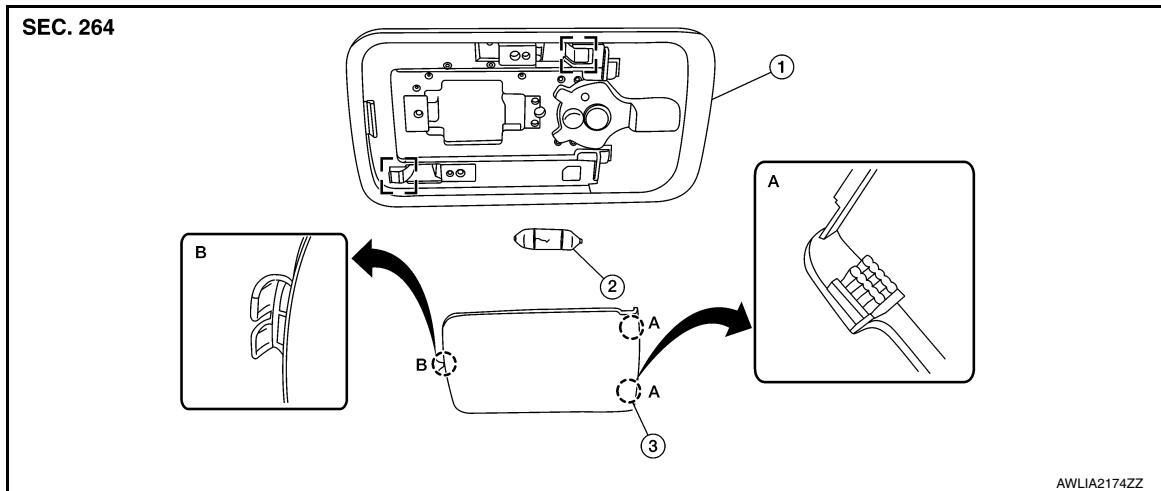

- | | | |
|--|--|---------|
| 1. Cargo lamp | 2. Bulb | 3. Lens |
| A. Pawls to release first for lens removal | B. Pawl to install first for lens installation | ⊖ Pawl |
| ⊖ Metal clip | | |

Removal and Installation

INFOID:000000009175472

REMOVAL

1. Insert a suitable tool into the gap between the headlining and cargo lamp and gently release the metal clips and remove.
2. Disconnect the harness connector from cargo lamp.

INSTALLATION

Installation is in the reverse order of removal.

Bulb or Lens Replacement

INFOID:000000009175473

WARNING:

Do not touch the glass surface of a bulb while it is lit or right after being turned OFF to prevent burns.

CAUTION:

- Do not touch the glass of bulb directly by hand. Keep grease and other oily substances away from bulb surface.
 - Do not leave bulb out of lamp reflector for a long time because dust, moisture, smoke, etc. may affect the performance of lamp.
 - Release and insert pawl as indicated in exploded view or damage may occur.
1. Beginning at the switch end, insert a suitable tool into the gap between the lens and cargo lamp, then gently release the lens pawls and remove.
 2. Push the tab to release one bulb end, then grasp the bulb and pull out the second end from its socket to remove.
 3. Install cargo lamp bulb to cargo lamp.
 4. Insert pawl at the end opposite the switch first, then insert the remaining two pawls to lock the lens in position.

ILLUMINATION CONTROL SWITCH

< REMOVAL AND INSTALLATION >

ILLUMINATION CONTROL SWITCH

Removal and Installation

INFOID:000000009175474

Removal

1. Remove cluster lid A. Refer to [IP-21. "Removal and Installation"](#).
2. Release the harness connector from cluster lid A.

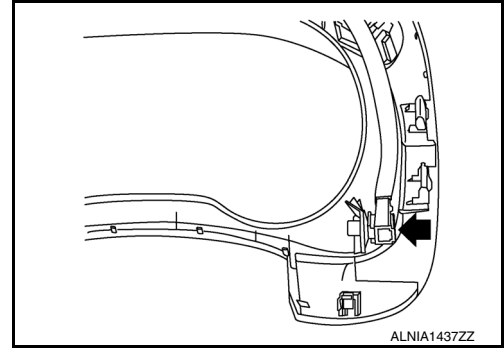

3. Release the pawls (A) and remove illumination control switch (1) through the front of cluster lid A (2).

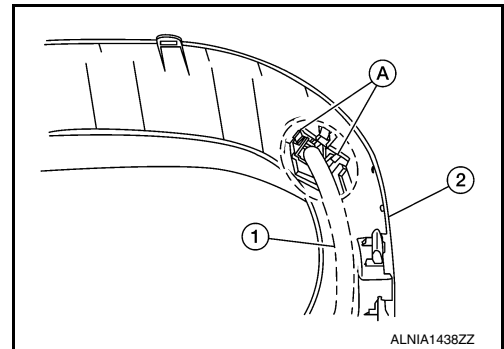

INSTALLATION

Installation is in the reverse order of removal.

A
B
C
D
E
F
G
H
I
J
K
L
M
N
O
P

INL

SERVICE DATA AND SPECIFICATIONS (SDS)

< SERVICE DATA AND SPECIFICATIONS (SDS)

SERVICE DATA AND SPECIFICATIONS (SDS)

SERVICE DATA AND SPECIFICATIONS (SDS)

Bulb Specifications

INFOID:000000009175475

Item	Wattage (W)*
Front room/map lamp	LED
Illumination control switch	—
Vanity lamp (if equipped)	2
Glove box lamp	3.4
Foot lamp (if equipped)	3.4
Step lamp (If equipped)	3.4
Personal lamp	8
Cargo lamp	8

*:Always check with the parts department for the latest parts information.