

SECTION **RSU**
 REAR SUSPENSION

A
B
C
D

RSU

CONTENTS

PRECAUTION	2	RADIUS ROD	12	F
PRECAUTIONS	2	Exploded View	12	
Precaution for Supplemental Restraint System (SRS) "AIR BAG" and "SEAT BELT PRE-TENSIONER"	2	Removal and Installation	12	
Precautions for Suspension	2	FRONT LOWER LINK	13	G
PREPARATION	3	Exploded View	13	
PREPARATION	3	Removal and Installation	13	H
Special Service Tool	3	REAR STABILIZER	15	
Commercial Service Tool	3	Exploded View	15	I
SYMPTOM DIAGNOSIS	4	Removal and Installation	15	
NOISE, VIBRATION AND HARSHNESS (NVH) TROUBLESHOOTING	4	REAR SUSPENSION ARM	17	J
NVH Troubleshooting Chart	4	Exploded View	17	
PERIODIC MAINTENANCE	5	Removal and Installation	17	
REAR SUSPENSION ASSEMBLY	5	UNIT REMOVAL AND INSTALLATION	19	K
On-vehicle Service	5	REAR SUSPENSION MEMBER	19	
Inspection	5	Exploded View	19	L
Inspection and Adjustment	6	Removal and Installation	20	
REMOVAL AND INSTALLATION	8	UNIT DISASSEMBLY AND ASSEMBLY ...	22	M
REAR LOWER LINK & COIL SPRING	8	REAR SHOCK ABSORBER	22	
Exploded View	8	Exploded View	22	N
Removal and Installation	8	Disassembly and Assembly	22	
REAR SHOCK ABSORBER	10	SERVICE DATA AND SPECIFICATIONS (SDS)	23	O
Exploded View	10	SERVICE DATA AND SPECIFICATIONS (SDS)	23	
Removal and Installation	10	Wheel Alignment (Unladen*)	23	P
Disposal	11	Ball Joint	23	
		Wheelarch Height	23	

PRECAUTIONS

< PRECAUTION >

PRECAUTION

PRECAUTIONS

Precaution for Supplemental Restraint System (SRS) "AIR BAG" and "SEAT BELT PRE-TENSIONER"

INFOID:000000009729245

The Supplemental Restraint System such as "AIR BAG" and "SEAT BELT PRE-TENSIONER", used along with a front seat belt, helps to reduce the risk or severity of injury to the driver and front passenger for certain types of collision. Information necessary to service the system safely is included in the SR and SB section of this Service Manual.

WARNING:

- To avoid rendering the SRS inoperative, which could increase the risk of personal injury or death in the event of a collision which would result in air bag inflation, all maintenance must be performed by an authorized NISSAN/INFINITI dealer.
- Improper maintenance, including incorrect removal and installation of the SRS, can lead to personal injury caused by unintentional activation of the system. For removal of Spiral Cable and Air Bag Module, see the SR section.
- Do not use electrical test equipment on any circuit related to the SRS unless instructed to in this Service Manual. SRS wiring harnesses can be identified by yellow and/or orange harnesses or harness connectors.

PRECAUTIONS WHEN USING POWER TOOLS (AIR OR ELECTRIC) AND HAMMERS

WARNING:

- When working near the Airbag Diagnosis Sensor Unit or other Airbag System sensors with the Ignition ON or engine running, DO NOT use air or electric power tools or strike near the sensor(s) with a hammer. Heavy vibration could activate the sensor(s) and deploy the air bag(s), possibly causing serious injury.
- When using air or electric power tools or hammers, always switch the Ignition OFF, disconnect the battery and wait at least three minutes before performing any service.

Precautions for Suspension

INFOID:000000009177386

- When installing rubber bushings, the final tightening must be carried out under unladen conditions with tires on ground. Spilled oil might shorten the life of rubber bushings. Be sure to wipe off any spilled oil.
- Unladen conditions mean that fuel, engine coolant and lubricant are full. Spare tire, jack, hand tools and mats are in designated positions.
- After servicing suspension parts, be sure to check wheel alignment.
- Self-lock nuts are not reusable. Always use new ones when installing. Since new self-lock nuts are pre-oiled, tighten as they are.
- The tightening surface must be kept free of oil/grease.
- When jacking up the vehicle with a floor jack, never hang the jack on the suspension beam.

PREPARATION

< PREPARATION >

PREPARATION

PREPARATION

Special Service Tool

INFOID:000000009177388

The actual shapes of Kent-Moore tools may differ from those of special service tools illustrated here.

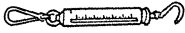
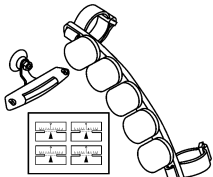
Tool number (Kent-Moore No.) Tool name	Description
(—) (J-44372) Pull gauge  LST024	Measuring ball joint swinging force
— (J-49286) Drift and Pull gauge  AWEIA0156ZZ	Measuring drift and pull

Commercial Service Tool

INFOID:000000009177389

Tool name	Description
Power tool  PIIB1407E	Loosening nuts, screws and bolts

A
B
C
D
F
G
H
I
J
K
L
M
N
O
P

RSU

NOISE, VIBRATION AND HARSHNESS (NVH) TROUBLESHOOTING

< SYMPTOM DIAGNOSIS >

SYMPTOM DIAGNOSIS

NOISE, VIBRATION AND HARSHNESS (NVH) TROUBLESHOOTING

NVH Troubleshooting Chart

INFOID:000000009177387

Use chart below to find the cause of the symptom. If necessary, repair or replace these parts.

Symptom		Possible cause and SUSPECTED PARTS		Reference page												
				RSU-8, RSU-10, RSU-12, RSU-13, RSU-15, RSU-17, RSU-19	RSU-10	—	—	—	RSU-8, RSU-10, RSU-12, RSU-13, RSU-15, RSU-17, RSU-19	RSU-6, "Inspection and Adjustment"	RSU-6, "Inspection and Adjustment"	DLN-101, "NVH Troubleshooting Chart"	DLN-114, "NVH Troubleshooting Chart"	RAX-4, "NVH Troubleshooting Chart"	WT-56, "NVH Troubleshooting Chart"	WT-56, "NVH Troubleshooting Chart"
REAR SUSPENSION	Noise	x	x	x	x	x	x			x	x	x	x	x	x	x
	Shake	x	x	x	x		x			x		x	x	x	x	x
	Vibration	x	x	x	x	x				x		x	x		x	
	Shimmy	x	x	x	x			x				x	x	x		x
	Shudder	x	x	x								x	x	x		x
	Poor quality ride or handling	x	x	x	x	x		x	x				x	x	x	

x: Applicable

REAR SUSPENSION ASSEMBLY

< PERIODIC MAINTENANCE >

PERIODIC MAINTENANCE

REAR SUSPENSION ASSEMBLY

On-vehicle Service

INFOID:000000009177390

- Check the suspension parts for excessive play, cracks, wear or damage. Shake each rear wheel to check for excessive play.
- Retighten all nuts and bolts to the specified torque.
- Make sure that each cotter pin is installed (if equipped).
- Check the shock absorber for oil leakage or other damage.
- Check the wheelarch height. Refer to [RSU-23, "Wheelarch Height"](#).
- Check the suspension ball joint for grease leakage and the ball joint dust cover for cracks or other damage.

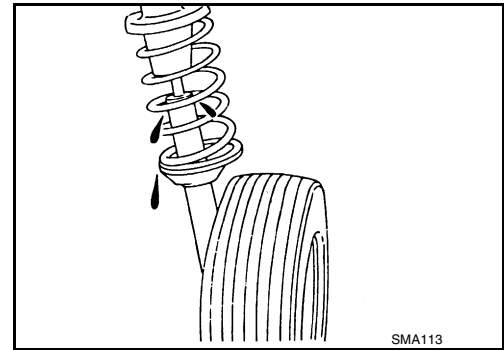

Inspection

INFOID:000000009177391

SHOCK ABSORBER ASSEMBLY

- Check for smooth operation through a full stroke for both compression and extension.
- Check for oil leakage on the welded or gland packing portions.
- Check the shock absorber piston rod for cracks, deformation or other damage and replace if necessary.

SUSPENSION ARM

- Check the suspension arm for damage, cracks, deformation and replace if necessary.
- Check the rubber bushings for damage, cracks and deformation. Replace suspension arm if necessary.
- Check the ball joint. Replace the suspension arm assembly if any of the following conditions exist:
 - Ball stud is worn.
 - Joint is hard to swing.
 - Check if the swinging force (A), rotating torque (B), or vertical end play (C) is out of specification using Tool.

Tool number : — (J-44372)

NOTE:

Before checking specifications, turn the ball joint at least 10 revolutions so the ball joint is properly broken in.

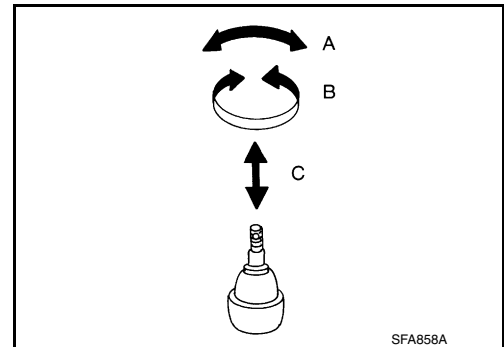

Swinging force (A) : Refer to [RSU-23, "Ball Joint"](#).

Rotating torque (B) : Refer to [RSU-23, "Ball Joint"](#).

Vertical end play (C) : Refer to [RSU-23, "Ball Joint"](#).

RADIUS ROD

- Check the radius rod for any deformation, cracks, or damage and replace if necessary.
- After installing the radius rod, check the wheel alignment and adjust if necessary. Refer to [RSU-23, "Wheel Alignment \(Unladen*\)"](#).

FRONT LOWER LINK

- Check the front lower link for any deformation, cracks, or damage and replace if necessary.

UPPER AND LOWER RUBBER SEATS

- Check the upper and lower rubber seats for deterioration or cracks and replace if necessary.

REAR LOWER LINK AND COIL SPRING

REAR SUSPENSION ASSEMBLY

< PERIODIC MAINTENANCE >

- Check the rear lower link and coil spring for any deformation, cracks, or other damage and replace if necessary.

STABILIZER BAR

- Check the stabilizer bar and clamps for any deformation, cracks or damage and replace if necessary.
- Check the rubber bushings for deterioration or cracks and replace if necessary.

Inspection and Adjustment

INFOID:000000009177392

Before checking the rear wheel alignment, make a preliminary inspection.

- Measure the wheel alignment under unladen conditions.

NOTE:

Unladen conditions mean that fuel, engine coolant, and lubricants are full and that the spare tire, jack, hand tools and mats are in their designated positions.

PRELIMINARY INSPECTION

- Check the tires for wear and for improper inflation.
- Check the wheels for deformation, cracks, and other damage. Remove the wheel and check the wheel runout. Refer to [WT-58, "Adjustment"](#).
- Check the rear wheel bearings for looseness.
- Check the rear suspension for looseness.
- Check that the rear shock absorbers work properly.
- Check the wheelarch height in the unladen condition. Refer to [RSU-23, "Wheelarch Height"](#).

GENERAL INFORMATION AND RECOMMENDATIONS

1. A Four-Wheel Thrust Alignment should be performed.
 - This type of alignment is recommended for any NISSAN/INFINITI vehicle.
 - The four-wheel "thrust" process helps ensure that the vehicle is properly aligned and the steering wheel is centered.
 - The alignment machine itself should be capable of accepting any NISSAN/INFINITI vehicle.
 - The alignment machine should be checked to ensure that it is level.
2. Make sure the alignment machine is properly calibrated.
 - Your alignment machine should be regularly calibrated in order to give correct information.
 - Check with the manufacturer of your specific alignment machine for their recommended Service/Calibration Schedule.

THE ALIGNMENT PROCESS

IMPORTANT: Use only the alignment specifications listed in this Service Manual. Refer to [RSU-23, "Wheel Alignment \(Unladen*\)"](#).

1. When displaying the alignment settings, many alignment machines use "indicators": (Green/red, plus or minus, Go/No Go). **Do NOT use these indicators.**
 - The alignment specifications programmed into your alignment machine that operate these indicators may not be correct.
 - This may result in an ERROR.
2. Most camera-type alignment machines are equipped with both "Rolling Compensation" method and optional "Jacking Compensation" method to "compensate" the alignment targets or head units. "Rolling Compensation" is the preferred method.
 - If using the "Rolling Compensation" method, after installing the alignment targets or head units, push or pull on the rear wheel to move the vehicle. Do not push or pull the vehicle body.
 - If using the "Jacking Compensation" method, after installing the alignment targets or head units, raise the vehicle and rotate the wheels 1/2 turn both ways.

NOTE:

Do not use the "Rolling Compensation" method if you are using sensor-type alignment equipment.

- Follow all instructions for the alignment machine you're using for more information.

CAMBER

- Measure the camber of both the right and left wheels using a suitable alignment gauge and adjust using the following procedure.

Camber : Refer to [RSU-23, "Wheel Alignment \(Unladen*\)"](#).

REAR SUSPENSION ASSEMBLY

< PERIODIC MAINTENANCE >

- If the camber is not within specification, adjust the camber by turning the adjusting bolts in the same direction.
1. Turn the adjusting bolts in the same direction to calibrate.
NOTE:
Camber changes about $0^{\circ} 5'$ (0.08°) with each graduation of the adjusting bolt.

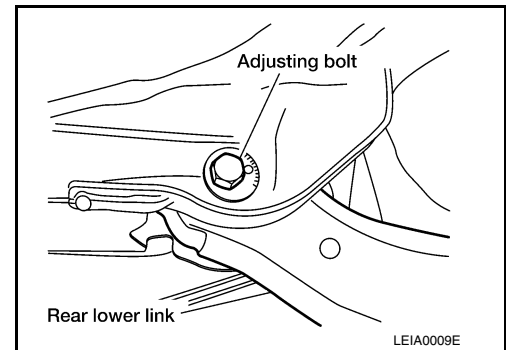
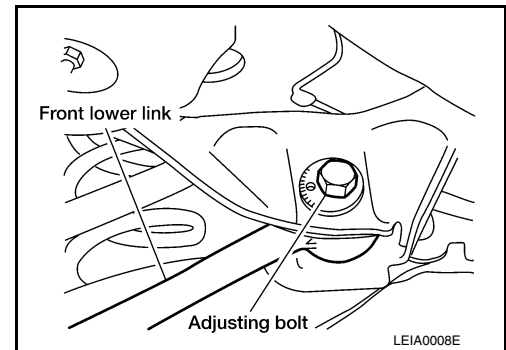

2. Tighten the adjusting bolt nuts to the specified torque.

Adjusting bolt nuts : Refer to [RSU-19, "Exploded View"](#).

TOE-IN

- Measure the toe-in of the rear wheels. If out of specification, inspect and replace any damaged or worn rear suspension parts before adjusting.

Total toe-in : Refer to [RSU-23, "Wheel Alignment \(Unladen*\)"](#).

- Adjust toe-in by turning adjusting bolt on rear lower link.
NOTE:
Toe changes about 1.5 mm (0.059 in) [one side] with each graduation of the adjusting bolt.
- After adjusting, tighten the adjusting bolt nut to the specified torque.

Adjusting bolt nut : Refer to [RSU-19, "Exploded View"](#).

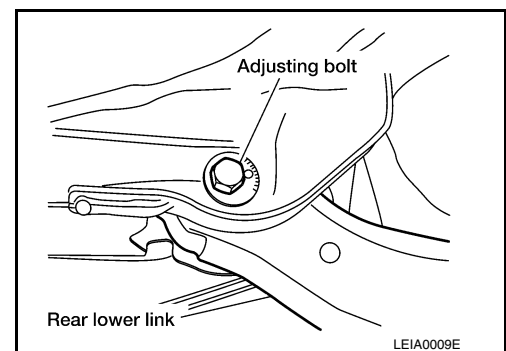

REAR LOWER LINK & COIL SPRING

< REMOVAL AND INSTALLATION >

REMOVAL AND INSTALLATION

REAR LOWER LINK & COIL SPRING

Exploded View

INFOID:000000009177393

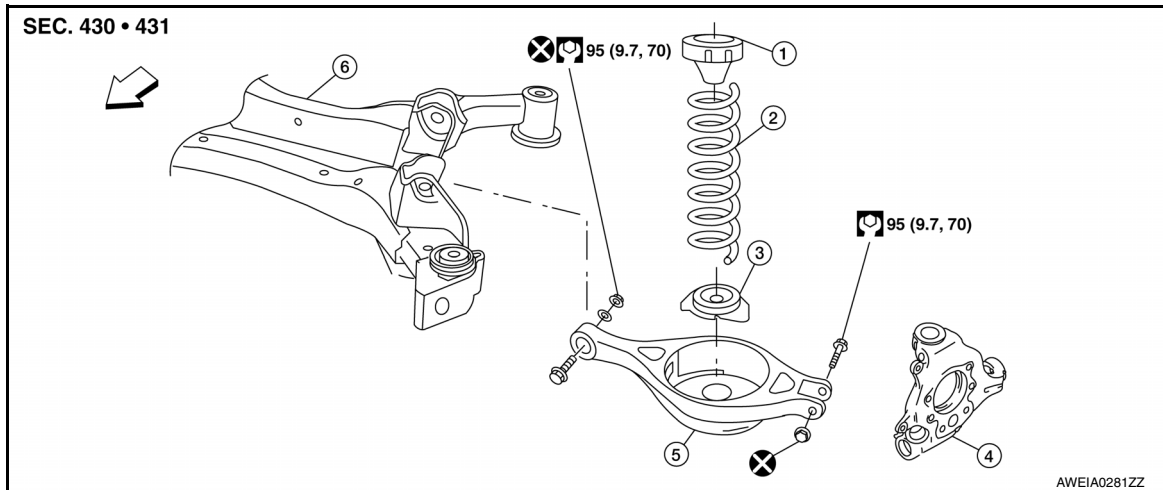

- | | | |
|-----------------|--------------------|---------------------------|
| 1. Upper seat | 2. Coil spring | 3. Lower seat |
| 4. Rear knuckle | 5. Rear lower link | 6. Rear suspension member |

⇐ Front

Removal and Installation

INFOID:000000009177394

REMOVAL

1. Remove the rear wheel and tire using power tool. Refer to [WT-58. "Adjustment"](#).
2. Put alignment marks on the adjusting bolt and on the rear lower link.

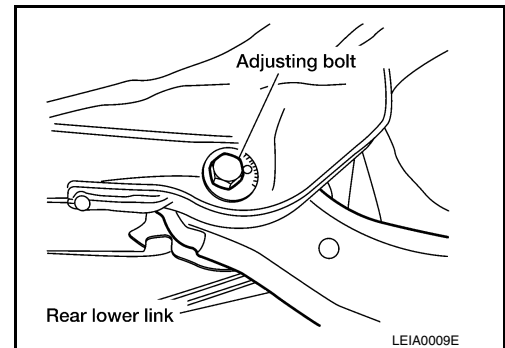

3. Loosen the rear lower link adjusting bolt on the rear suspension member.
4. Support the rear lower link with a suitable jack.
WARNING:
Place a suitable jack under the outer end of the rear lower link.
CAUTION:
Do not damage the rear lower link with the suitable jack.
5. Support the rear knuckle with a suitable jack.
WARNING:
Place a suitable jack under the center of the rear knuckle.
CAUTION:
Do not damage the rear knuckle with the suitable jack.
6. Remove the rear lower link nut and bolt from the rear knuckle using power tool.

REAR LOWER LINK & COIL SPRING

< REMOVAL AND INSTALLATION >

7. Slowly lower the suitable jack supporting the rear lower link. Remove the upper seat, the coil spring, and the lower seat from the rear lower link.
8. Remove the rear lower link nut and bolt from the rear suspension member using power tool.
9. Remove the rear lower link.

INSTALLATION

Installation is in the reverse order of removal.

- Make sure that the upper seat is attached as shown.

CAUTION:

- Keep the upper seat (1) in place during coil spring installation. The protrusion (A) on the upper seat faces the outside of the vehicle.
- Align the tabs (C) to the upper seat openings and securely fit the bracket (2) to the tabs (B).

⇐ : Body

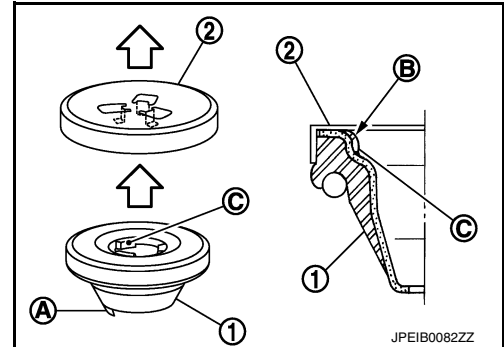

- Match up the lower seat indentions and the rear lower link grooves.
- When installing the coil spring (1), position the coil spring as shown.

(A): Vehicle upper side

(B): 1 paint mark

(C): 2 paint marks

(D): Vehicle inside

CAUTION:

Position the coil spring with the 2 paint marks 3.5 turns from the bottom.

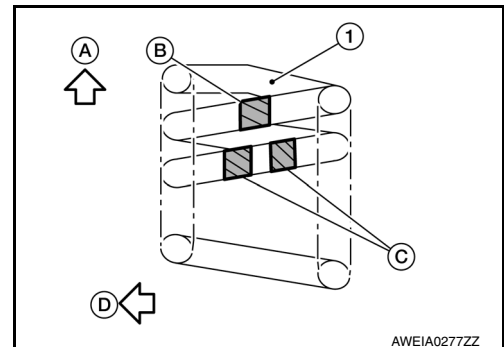

- Install the coil spring by aligning the lower end of the coil spring (1) to the bump on the lower spring seat (2).

(A) : Maximum gap 5 mm (0.20 in)

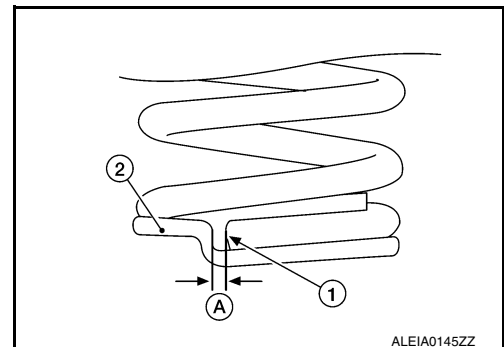

- Perform the final tightening of the parts under unladen conditions with the tires on the ground.
- Check the wheel alignment. Refer to [RSU-6. "Inspection and Adjustment"](#).
- Adjust the neutral position of the steering angle sensor. Refer to [BRC-55. "Work Procedure"](#).

REAR SHOCK ABSORBER

< REMOVAL AND INSTALLATION >

REAR SHOCK ABSORBER

Exploded View

INFOID:000000009177395

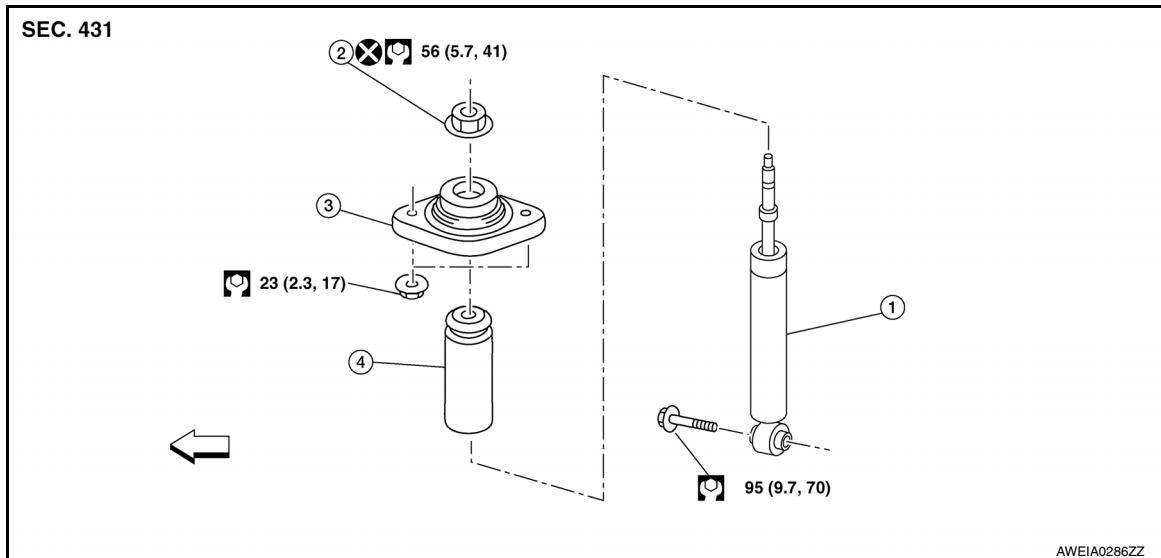

- 1. Rear shock absorber
 - 2. Piston rod lock nut
 - 3. Shock absorber insulator
 - 4. Bound bumper
- ← Front

Removal and Installation

INFOID:000000009177396

REMOVAL

1. Remove the rear wheel and tire using power tool. Refer to [WT-58, "Adjustment"](#).
2. Set a suitable jack under the rear lower link to relieve the coil spring tension.

WARNING:

Place a suitable jack under the outer end of the rear lower link.

CAUTION:

Do not damage the rear lower link with the suitable jack.

3. Remove the lower rear shock absorber bolt (A) with power tool.

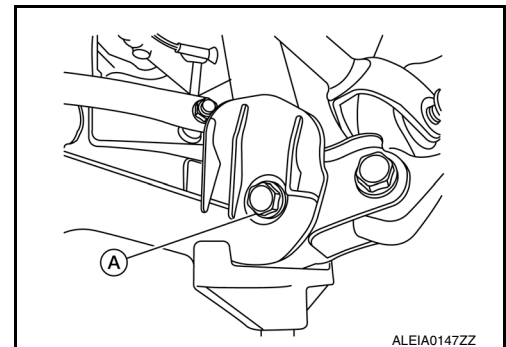

4. Gradually lower the suitable jack to separate the rear shock absorber from the rear lower link.

REAR SHOCK ABSORBER

< REMOVAL AND INSTALLATION >

5. Remove the rear shock absorber nuts (←).

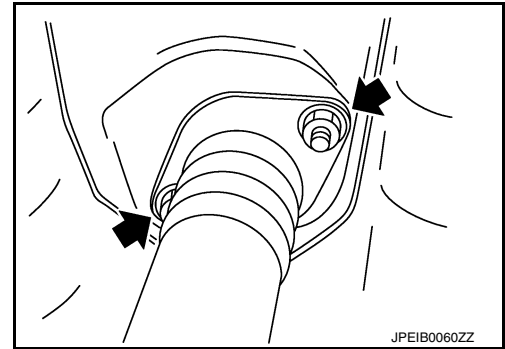

6. Remove the rear shock absorber.

INSTALLATION

Installation is in the reverse order of removal.

- Perform the final tightening of the parts under unladen conditions with the tires on the ground.

Disposal

INFOID:000000009177397

1. Set the shock absorber horizontally with the piston rod fully extended.
2. Drill a 2 – 3 mm (0.08 – 0.12 in) hole at the position (●) as shown to release gas gradually.

CAUTION:

- Wear eye protection (safety glasses).
- Wear gloves.
- Be careful with metal chips or oil blown out by the compressed gas.

NOTE:

- Drill vertically in this direction (←) directly into the outer tube avoiding brackets.
- The gas is clear, colorless, odorless, and harmless.

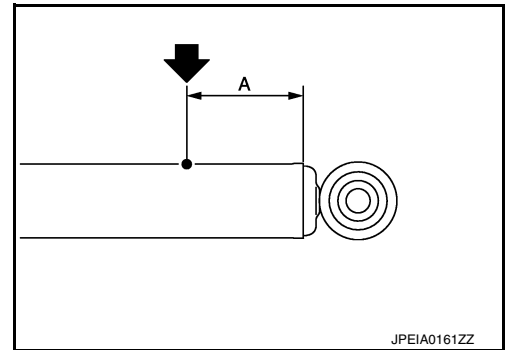

(A) : 20 – 30 mm (0.79 – 1.18 in)

3. Position the drilled hole downward and drain the oil by moving the piston rod several times.

CAUTION:

Dispose of drained oil according to the law and local regulations.

A
B
C
D
F
G
H
I
J
K
L
M
N
O
P

RSU

RADIUS ROD

< REMOVAL AND INSTALLATION >

RADIUS ROD

Exploded View

INFOID:000000009760274

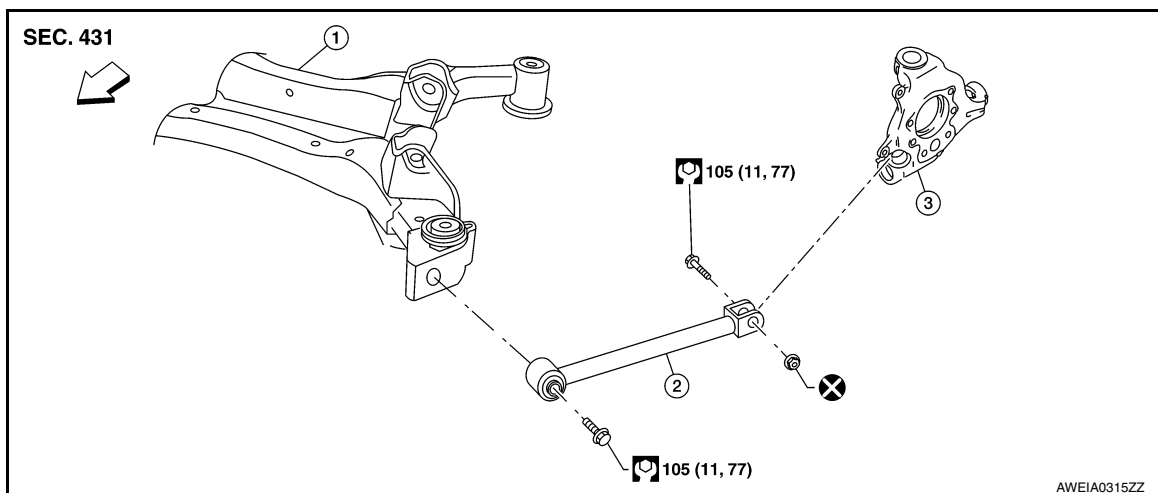

1. Rear suspension member

2. Radius rod

3. Rear knuckle

⇐ Front

Removal and Installation

INFOID:000000009177399

REMOVAL

1. Remove the rear wheel and tire using power tool. Refer to [WT-58, "Adjustment"](#).
2. Remove the radius rod bolt and nut from the rear knuckle using power tool.
3. Remove the radius rod bolt from the rear suspension member using power tool.
4. Remove the radius rod.

INSTALLATION

Installation is in the reverse order of removal.

CAUTION:

Do not reuse the radius rod nut.

FRONT LOWER LINK

< REMOVAL AND INSTALLATION >

FRONT LOWER LINK

Exploded View

INFOID:000000009760275

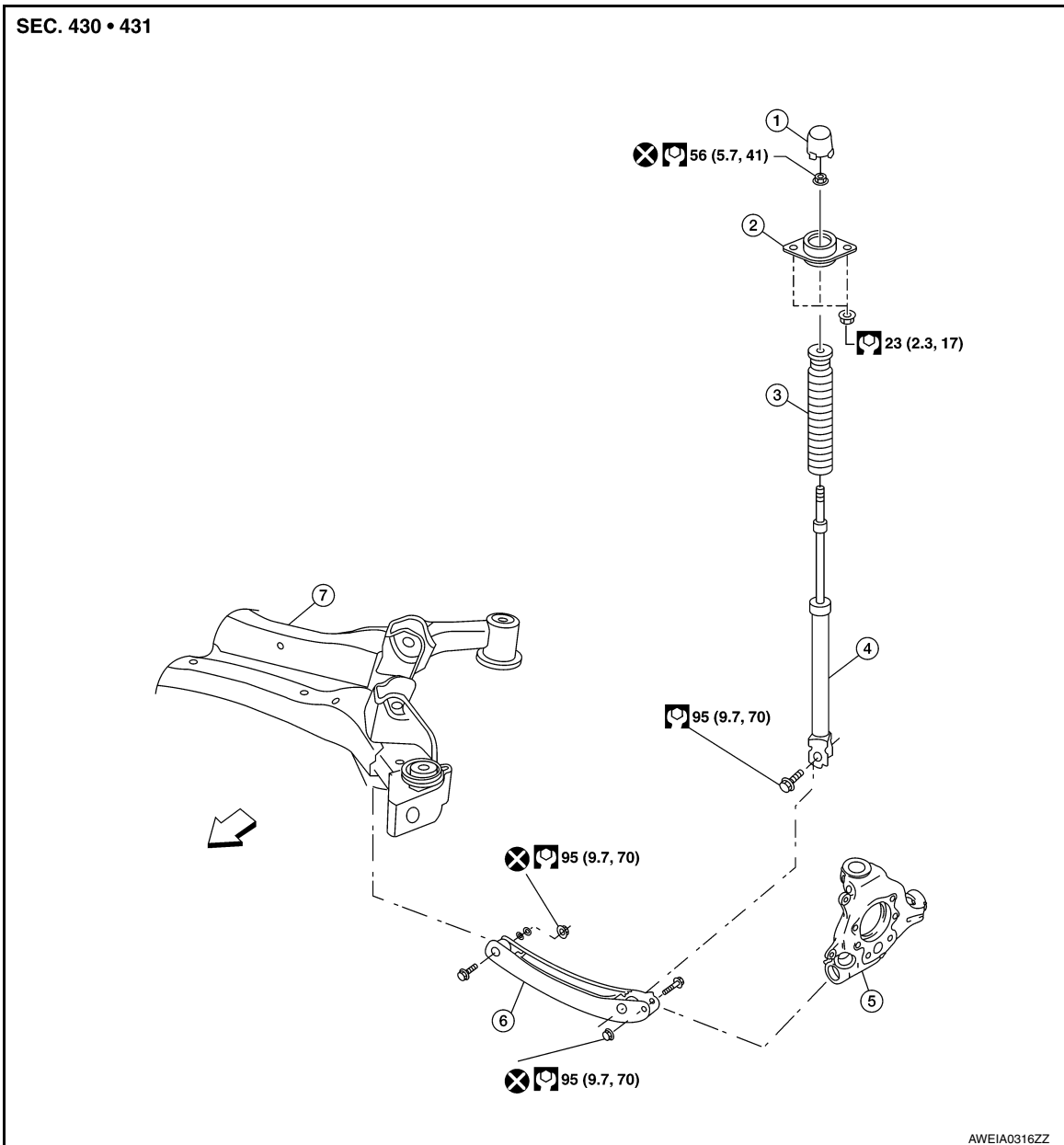

- | | | |
|---------------------------|-----------------------------|---------------------|
| 1. Cap | 2. Shock absorber insulator | 3. Bound bumper |
| 4. Rear shock absorber | 5. Rear knuckle | 6. Front lower link |
| 7. Rear suspension member | ↔ Front | |

Removal and Installation

INFOID:000000009177401

REMOVAL

1. Remove the rear wheel and tire using power tool. Refer to [WT-65. "Road Wheel"](#).
2. Support the rear lower link with a suitable jack.

WARNING:

Place a suitable jack under the outer end of the rear lower link.

CAUTION:

Do not damage the rear lower link with the suitable jack.

A
B
C
D
RSU
F
G
H
I
J
K
L
M
N
O
P

FRONT LOWER LINK

< REMOVAL AND INSTALLATION >

- Support the rear knuckle with a suitable jack.

WARNING:

Place a suitable jack under the center of the rear knuckle.

CAUTION:

Do not damage the rear knuckle with the suitable jack.

- Index mark the adjusting bolt to the rear suspension member.

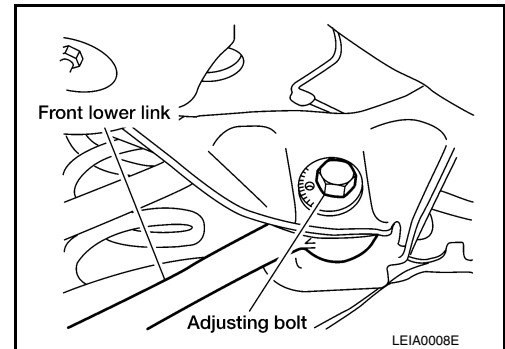

- Remove the lower shock absorber bolt using power tool. Refer to [RSU-19. "Exploded View"](#).
- Remove the coil spring. Refer to [RSU-8. "Removal and Installation"](#).
- Remove the front lower link bolt and nut from the rear suspension member using power tool.
- Remove the front lower link bolt and nut from the rear knuckle using power tool.
- Remove the front lower link cover.
- Remove the front lower link.

INSTALLATION

Installation is in the reverse order of removal.

CAUTION:

Do not reuse the front lower link nuts.

- Perform the final tightening of the parts under unladen conditions with the tires on the ground.
- Check the wheel alignment. Refer to [RSU-6. "Inspection and Adjustment"](#).
- Adjust the neutral position of the steering angle sensor. Refer to [BRC-55. "Work Procedure"](#).

REAR STABILIZER

< REMOVAL AND INSTALLATION >

REAR STABILIZER

Exploded View

INFOID:000000009177402

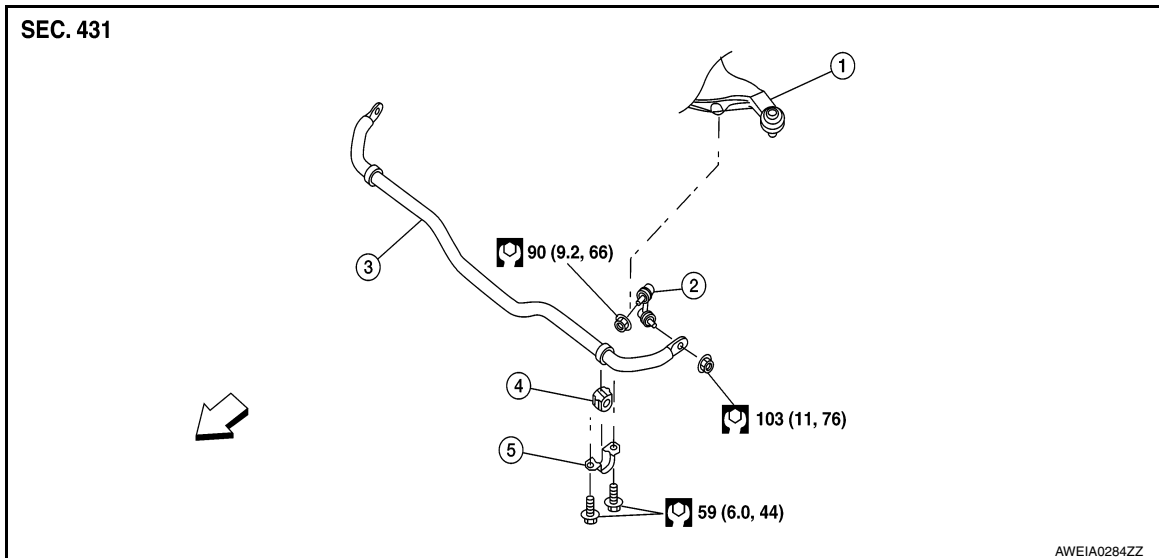

- | | | |
|---------------------------|-------------------------|-------------------|
| 1. Rear suspension arm | 2. Connecting rod (LH) | 3. Stabilizer bar |
| 4. Stabilizer bar bushing | 5. Stabilizer bar clamp | ⇐ Front |

Removal and Installation

INFOID:000000009177403

REMOVAL

1. Apply matching marks to the rear suspension arms, the connecting rods, and the stabilizer shaft to identify the installation position.
2. Remove both upper connecting rod nuts (A). Disconnect both connecting rods from the rear suspension arms.

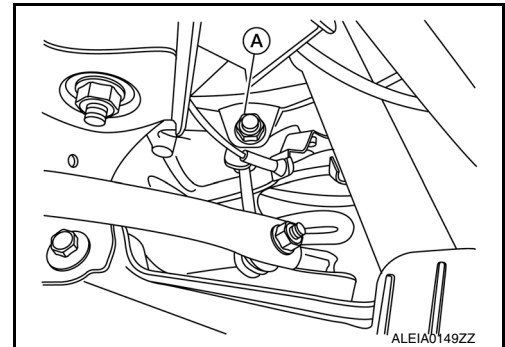

3. Remove the 4 stabilizer clamp bolts (A) using power tool.

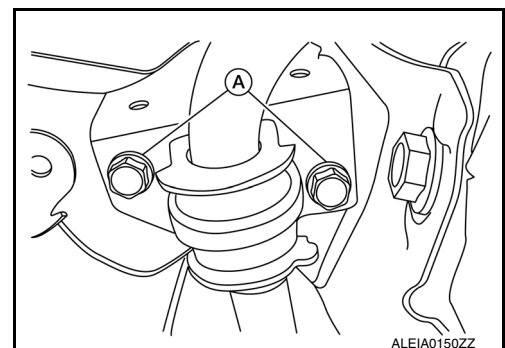

4. Remove the stabilizer clamps.
5. Remove the stabilizer bar bushings.

A
B
C
D
RSU
F
G
H
I
J
K
L
M
N
O
P

REAR STABILIZER

< REMOVAL AND INSTALLATION >

6. Remove the stabilizer bar.
7. Remove both lower connecting rod nuts. Disconnect both connecting rods from the stabilizer bar.

INSTALLATION

Installation is in the reverse order of removal.

- Position the stabilizer bar bushings with the slit facing the front of the vehicle.
- Align the matching marks when installing.
- Tighten the connecting rod nut to the specified torque while holding the hexagonal part of the connecting rod stud.

REAR SUSPENSION ARM

< REMOVAL AND INSTALLATION >

REAR SUSPENSION ARM

Exploded View

INFOID:000000009177404

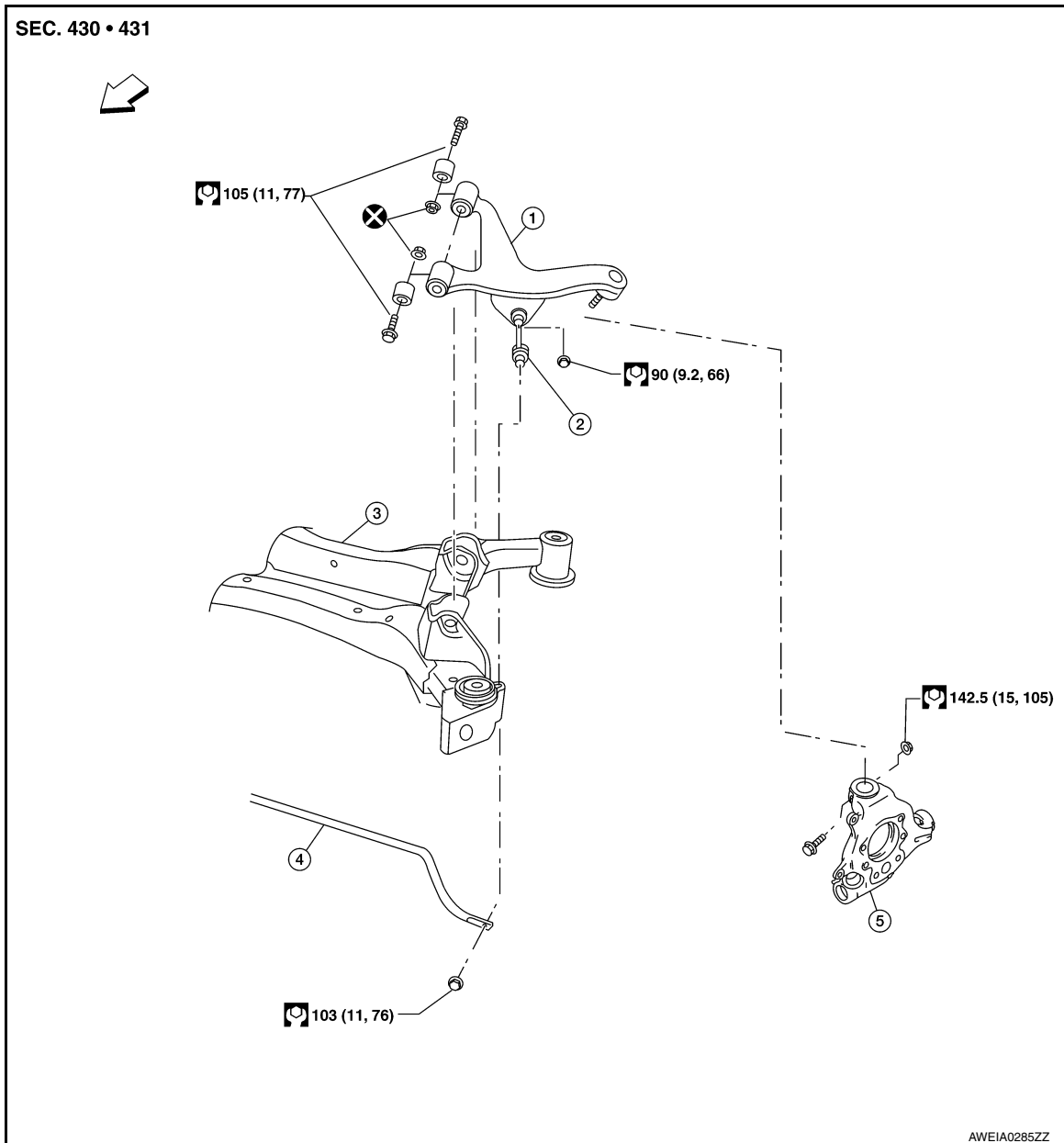

- | | | |
|------------------------|------------------------|---------------------------|
| 1. Rear suspension arm | 2. Connecting rod (LH) | 3. Rear suspension member |
| 4. Stabilizer bar | 5. Rear knuckle | ↔ Front |

Removal and Installation

INFOID:000000009177405

REMOVAL

1. Remove the rear wheel and tire using power tool. Refer to [WT-58, "Adjustment"](#).
2. Remove the brake caliper torque member bolts, leaving the brake hose attached. Position the caliper aside with wire. Refer to [BR-36, "BRAKE CALIPER ASSEMBLY : Removal and Installation"](#).
CAUTION:
Do not depress the brake pedal while the brake caliper is removed.
3. Put alignment marks on the disc brake rotor and on the wheel hub and bearing. Remove the disc brake rotor.

REAR SUSPENSION ARM

< REMOVAL AND INSTALLATION >

CAUTION:

Do not drop the disc brake rotor.

4. Remove the coil spring. Refer to [RSU-8, "Removal and Installation"](#).
5. Remove the upper connecting rod nut. Disconnect the connecting rod from the rear suspension arm. Refer to [RSU-15, "Exploded View"](#).
6. Remove the wheel sensor (1) and the wheel speed sensor harness from the rear knuckle. Refer to [BRC-119, "Exploded View - Rear Wheel Sensor"](#).

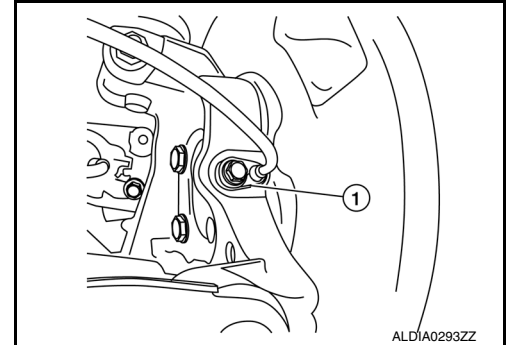

7. Remove the wheel speed sensor harness from rear suspension arm.
8. Remove the stabilizer bar. Refer to [RSU-15, "Exploded View"](#).
9. Remove the suspension arm bolt and nut from the rear knuckle using power tool. Disconnect the suspension arm from the rear knuckle.
10. Remove the suspension arm bolts and nuts from the rear suspension member using power tool.
11. Remove the suspension arm.

INSTALLATION

Installation is in the reverse order of removal.

CAUTION:

Do not reuse the rear suspension arm nuts at the rear suspension member.

- Perform the final tightening of the parts under unladen conditions with tires on the ground.
- Check the wheel sensor harness for proper connection. Refer to [BRC-119, "Exploded View - Rear Wheel Sensor"](#).
- Check the wheel alignment. Refer to [RSU-6, "Inspection and Adjustment"](#).
- Adjust the neutral position of the steering angle sensor. Refer to [BRC-55, "Work Procedure"](#).

REAR SUSPENSION MEMBER

< UNIT REMOVAL AND INSTALLATION >

UNIT REMOVAL AND INSTALLATION

REAR SUSPENSION MEMBER

Exploded View

INFOID:000000009177406

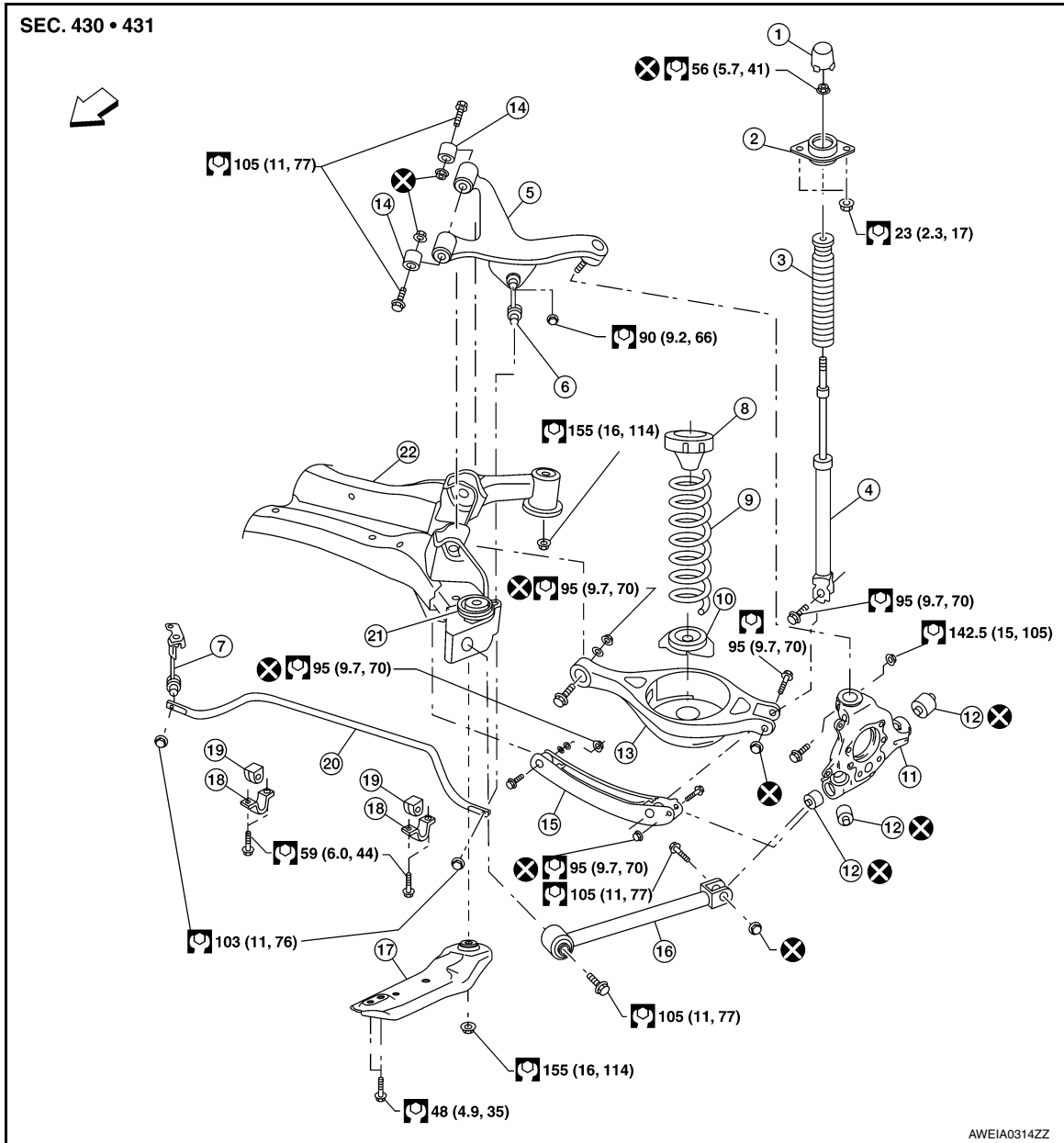

- | | | |
|----------------------------|-----------------------------|--------------------------|
| 1. Cap | 2. Shock absorber insulator | 3. Bound bumper |
| 4. Rear shock absorber | 5. Rear suspension arm | 6. Connecting rod (LH) |
| 7. Connecting rod (RH) | 8. Upper seat | 9. Coil spring |
| 10. Lower seat | 11. Rear knuckle | 12. Bushing |
| 13. Rear lower link | 14. Suspension arm bushings | 15. Front lower link |
| 16. Radius rod | 17. Front member stay (LH) | 18. Stabilizer bar clamp |
| 19. Stabilizer bar bushing | 20. Stabilizer bar | 21. Member stopper |
| 22. Rear suspension member | ← Front | |

REAR SUSPENSION MEMBER

< UNIT REMOVAL AND INSTALLATION >

Removal and Installation

INFOID:000000009177407

REMOVAL

1. Remove the rear wheels and tires using power tool. Refer to [WT-58, "Adjustment"](#).
2. Remove the brake calipers, leaving the brake hoses attached. Position the brake calipers aside with wire. Refer to [BR-40, "BRAKE CALIPER ASSEMBLY : Removal and Installation"](#).
CAUTION:
Do not depress the brake pedal while the caliper assembly is removed.
3. Put alignment marks on the disc brake rotors and on the wheel hubs and bearings. Remove the disc brake rotors.
CAUTION:
Do not drop the disc brake rotors.
4. Remove the wheel sensors (1) and the wheel sensor harness. Refer to [BRC-119, "Exploded View - Rear Wheel Sensor"](#).

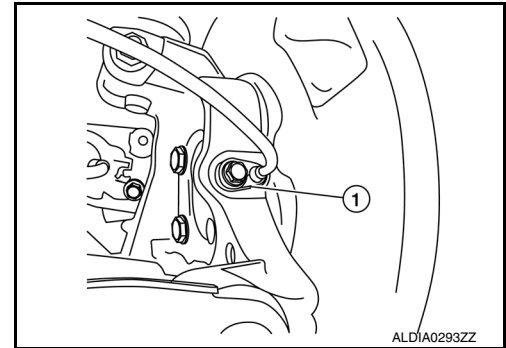

5. Remove the tail pipe. Refer to [EX-5, "Exploded View"](#).
6. Remove the stabilizer bar. Refer to [RSU-15, "Exploded View"](#).
7. Remove the drive shafts (4WD models). Refer to [DLN-103, "Removal and Installation"](#).
8. Remove the propeller shaft (4WD models). Refer to [DLN-103, "Removal and Installation"](#).
9. Remove the spare tire (4WD models).
10. Remove the harness from the rear final drive and from the rear suspension member (4WD models).
11. Remove the rear final drive (4WD models). Refer to [DLN-128, "Exploded View"](#).
12. Disconnect the parking brake cables from the rear knuckles, from the vehicle chassis, and from the rear suspension member. Refer to [PB-7, "Exploded View"](#).
13. Remove the rear lower links and the coil springs. Refer to [RSU-8, "Removal and Installation"](#).
14. Remove the shock absorber lower bolts. Refer to [RSU-10, "Exploded View"](#).
15. Set a suitable jack under the rear suspension member.
WARNING:
Place a suitable jack under the center of the rear suspension member.
CAUTION:
Do not damage the rear suspension member with the suitable jack.
16. Remove the front member stay (LH) and the front member stay (RH) from the vehicle chassis.
17. Slowly lower the jack. Remove the rear suspension member, the rear suspension arms, the radius rods, the front lower links, and the rear knuckles from the vehicle as a unit.
18. Remove each rear knuckle with the park brake components and the wheel hub and bearing as an assembly.
19. Remove the rear suspension arms. Refer to [RSU-17, "Exploded View"](#).
20. Remove the radius rods. Refer to [RSU-12, "Exploded View"](#).
21. Remove the front lower links. Refer to [RSU-13, "Exploded View"](#).

INSTALLATION

Installation is in the reverse order of the removal.

CAUTION:

- Do not reuse the rear suspension arm nuts at the rear suspension member.
- Do not reuse the rear lower link nuts.
- Do not reuse the front lower link nuts.

REAR SUSPENSION MEMBER

< UNIT REMOVAL AND INSTALLATION >

- Perform the final tightening of the parts under unladen conditions with the tires on the ground.
- Check the wheel sensor harness for proper connection. Refer to [BRC-119, "Exploded View - Rear Wheel Sensor"](#).
- Adjust the parking brake operation (stroke). Refer to [PB-4, "Inspection and Adjustment"](#).
- Check the wheel alignment. Refer to [RSU-6, "Inspection and Adjustment"](#).
- Adjust the neutral position of the steering angle sensor. Refer to [BRC-55, "Work Procedure"](#).

A
B
C
D
F
G
H
I
J
K
L
M
N
O
P

RSU

REAR SHOCK ABSORBER

< UNIT DISASSEMBLY AND ASSEMBLY >

UNIT DISASSEMBLY AND ASSEMBLY

REAR SHOCK ABSORBER

Exploded View

INFOID:000000009760280

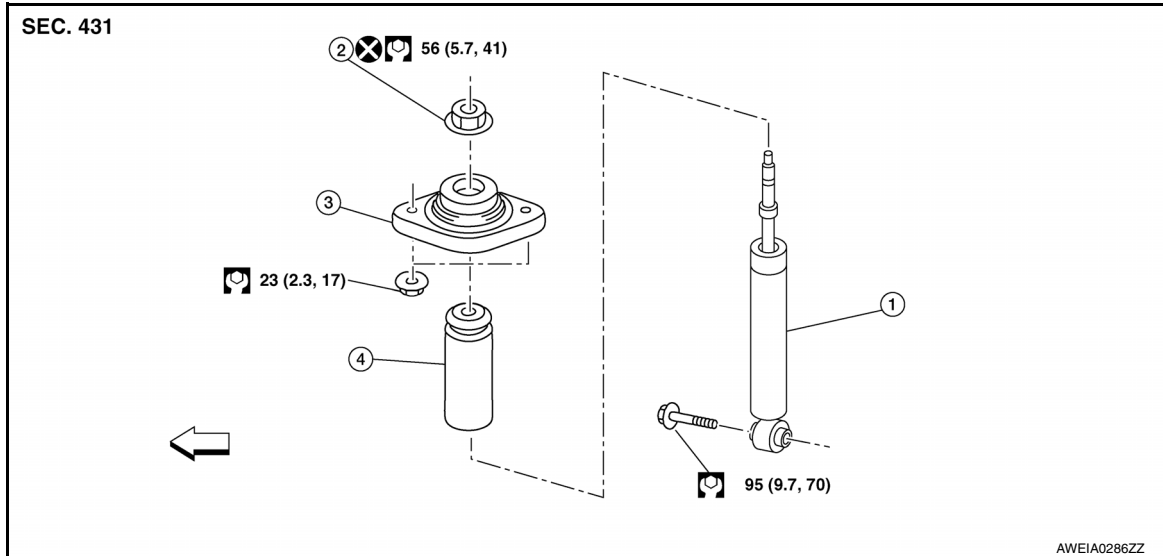

- 1. Rear shock absorber
 - 2. Piston rod lock nut
 - 3. Shock absorber insulator
 - 4. Bound bumper
- ← Front

Disassembly and Assembly

INFOID:000000009177408

DISASSEMBLY

CAUTION:

Do not damage the shock absorber piston rod when removing components from the shock absorber.

1. Remove the cap from the shock absorber insulator.
2. Wrap a shop cloth around the lower shock absorber bolt flange. Secure the lower shock absorber bolt flange in a vise.

CAUTION:

Do not set the cylindrical part of the rear shock absorber in a vise.

3. Secure the piston rod tip so that the piston rod does not turn. Remove the piston rod lock nut.
4. Remove the shock absorber insulator and the bound bumper from the rear shock absorber.

ASSEMBLY

Assembly is in the reverse order of disassembly.

CAUTION:

Do not reuse the piston rod lock nut.

SERVICE DATA AND SPECIFICATIONS (SDS)

< SERVICE DATA AND SPECIFICATIONS (SDS)

SERVICE DATA AND SPECIFICATIONS (SDS)

SERVICE DATA AND SPECIFICATIONS (SDS)

Wheel Alignment (Unladen*)

INFOID:000000009177409

A
B
C
D
E
F
G
H
I
J
K
L
M
N
O
P

RSU

Item		Standard
Camber Degree minute (Decimal degree)	Minimum	-1° 05' (-1.08°)
	Nominal	-0° 35' (-0.58°)
	Maximum	-0° 05' (-0.08°)

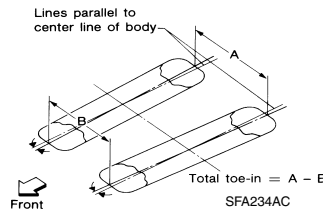

Total toe-in	Distance (A - B)	Minimum	Out 0.8 mm (Out 0.031 in)
		Nominal	In 2.2 mm (In 0.087 in)
		Maximum	In 5.2 mm (In 0.205 in)
	Angle (LH and RH) Degree minute (Decimal degree)	Minimum	Out 0° 2' 24" (Out 0.04°)
		Nominal	In 0° 9' 36" (In 0.16°)
		Maximum	In 0° 21' 36" (In 0.36°)

*: Fuel, engine coolant, and lubricants are full. Spare tire, jack, hand tools, and mats are in designated positions.

Ball Joint

INFOID:000000009177410

Item	Standard
Swing torque	0.5 – 3.4 N·m (0.05 – 0.35 kg-m, 4 – 30 in-lb)
Measurement on spring balance (cotter pinhole position)	8.1 – 54.8 N (0.83 – 5.59 kg, 1.82 – 12.32 lb)
Axial end play	0 mm (0 in)

Wheelarch Height

INFOID:000000009177411

UNITED STATES

SERVICE DATA AND SPECIFICATIONS (SDS)

< SERVICE DATA AND SPECIFICATIONS (SDS)

Unit: mm (in)

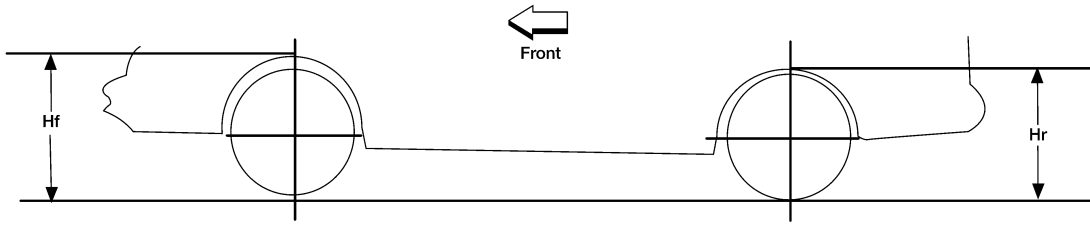

LEIA0085E

Axle type	2WD			4WD	
Wheel size	235/65R18		235/55R20	235/65R18	235/55R20
Grade	S, SV	SL	Platinum	S, SV	SL, Platinum
Front (Hf)	823 (32.40)	823 (32.40)	821 (32.32)	822 (32.36)	822 (32.36)
Rear (Hr)	828 (32.60)	827 (32.56)	825 (32.48)	827 (32.56)	826 (32.52)

Measure value under unladen conditions. (Fuel, engine coolant and lubricant are full. Spare tire, jack, hand tools and mats are in designated positions).

CANADA

Unit: mm (in)

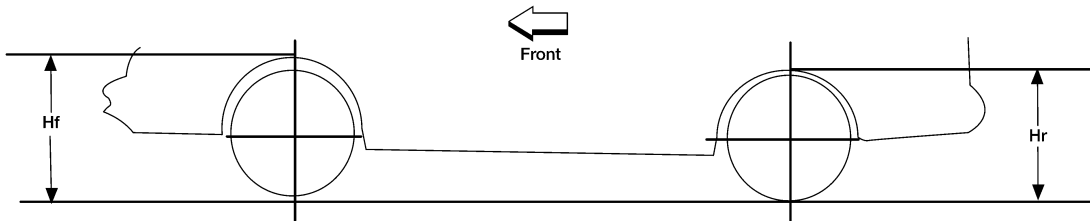

LEIA0085E

Axle type	2WD			4WD		
Wheel size	235/65R18			235/55R20		
Grade	S	SL	S	SV	SL	Platinum
Front (Hf)	823 (32.40)					822 (32.36)
Rear (Hr)	829 (32.64)	828 (32.60)			827 (32.56)	

Measure value under unladen* conditions. (Fuel, engine coolant and lubricant are full. Spare tire, jack, hand tools and mats are in designated positions).

MEXICO

SERVICE DATA AND SPECIFICATIONS (SDS)

< SERVICE DATA AND SPECIFICATIONS (SDS)

Unit: mm (in)

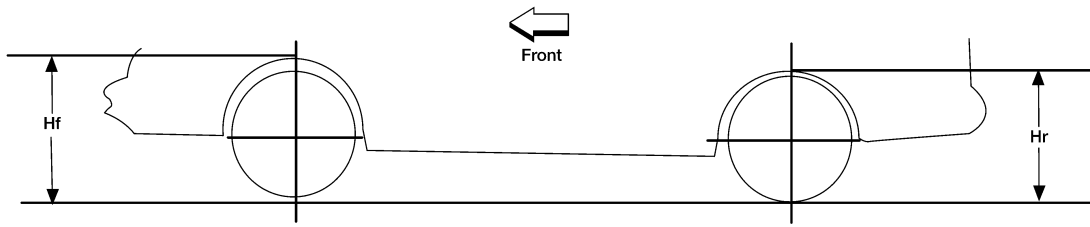

LEIA0085E

Axle type	2WD		4WD	
Wheel size	235/65R18		235/55R20	
Grade	Sense	Advance	Exclusive	Exclusive 4WD
Front (Hf)	823 (32.40)		821 (32.32)	
Rear (Hr)	828 (32.60)		826 (32.52)	825 (32.48)

Measure value under unladen* conditions. (Fuel, engine coolant and lubricant are full. Spare tire, jack, hand tools and mats are in designated positions).