

SECTION SN
SONAR SYSTEM

A
 B
 C
 D
 E
 F
 G
 H
 I
 J
 K
 L
 M
 SN
 O
 P

CONTENTS

<p>PRECAUTION 3</p> <p>PRECAUTION 3 Precaution for Supplemental Restraint System (SRS) "AIR BAG" and "SEAT BELT PRE-TENSIONER"3</p> <p>SYSTEM DESCRIPTION 4</p> <p>COMPONENT PARTS 4 Component Parts Location4 Component Description4</p> <p>SYSTEM 5 System Diagram5 System Description5</p> <p>DIAGNOSIS SYSTEM (SONAR CONTROL UNIT) 8 CONSULT Function8</p> <p>ECU DIAGNOSIS INFORMATION10</p> <p>SONAR CONTROL UNIT10 Reference Value 10 DTC Index 12</p> <p>WIRING DIAGRAM13</p> <p>SONAR SYSTEM13 Wiring Diagram 13</p> <p>BASIC INSPECTION18</p> <p>DIAGNOSIS AND REPAIR WORKFLOW18 Work Flow 18</p> <p>INSPECTION AND ADJUSTMENT20</p> <p>ADDITIONAL SERVICE WHEN REPLACING SONAR CONTROL UNIT20 ADDITIONAL SERVICE WHEN REPLACING SONAR CONTROL UNIT : Description20</p>	<p>ADDITIONAL SERVICE WHEN REPLACING SONAR CONTROL UNIT : Work Procedure20</p> <p>CONFIGURATION (SONAR CONTROL UNIT)20 CONFIGURATION (SONAR CONTROL UNIT) : Description21 CONFIGURATION (SONAR CONTROL UNIT) : Work Procedure21 CONFIGURATION (SONAR CONTROL UNIT) : Configuration List22</p> <p>DTC/CIRCUIT DIAGNOSIS23</p> <p>U1000 CAN COMM CIRCUIT23 DTC Logic23 Diagnosis Procedure23</p> <p>U1010 CONTROL UNIT (CAN)24 DTC Logic24</p> <p>B2720 CORNER SENSOR [RL]25 DTC Logic25 Diagnosis Procedure25</p> <p>B2721 CENTER SENSOR [RL]26 DTC Logic26 Diagnosis Procedure26</p> <p>B2722 CENTER SENSOR [RR]27 DTC Logic27 Diagnosis Procedure27</p> <p>B2723 CORNER SENSOR [RR]28 DTC Logic28 Diagnosis Procedure28</p> <p>B2724 SONAR CONTROL UNIT29 DTC Logic29</p> <p>B2725 REAR BUZZER30 DTC Logic30 Diagnosis Procedure30</p>
----------------------------------------------------------------------------------------------------------------------------------------------------------------------------------------------------------------------------------------------------------------------------------------------------------------------------------------------------------------------------------------------------------------------------------------------------------------------------------------------------------------------------------------------------------------------------------------------------------------------------------------------------------------------------------------------------------------------------------------------------------------------------------------------------------------------------------------------------------------------------------------------------------------------------------------------------------------------------------------------------------------------------------------------------------------------------------------------------------------------------------------------------------------------------------------------------------------------------------------------------------------------------------	---------------------------------------------------------------------------------------------------------------------------------------------------------------------------------------------------------------------------------------------------------------------------------------------------------------------------------------------------------------------------------------------------------------------------------------------------------------------------------------------------------------------------------------------------------------------------------------------------------------------------------------------------------------------------------------------------------------------------------------------------------------------------------------------------------------------------------------------------------------------------------------------------------------------------------------------------------------------------------------------------------------------------------------------------------------------------------------------------------------------------------------------------------------------------------------------------------------------------------------------------------------------------------------------------------------------------------------------------------------------------------------------------------------------------------------------------------------------------------------------------------------------------

POWER SUPPLY AND GROUND CIRCUIT	32	SONAR CONTROL UNIT	34
Diagnosis Procedure	32	Removal and Installation	34
SYMPTOM DIAGNOSIS	33	SONAR SENSOR	35
SONAR SYSTEM	33	Removal and Installation	35
Symptom Table	33	BUZZER	36
REMOVAL AND INSTALLATION	34	Removal and Installation	36

PRECAUTION

< PRECAUTION >

PRECAUTION

PRECAUTION

Precaution for Supplemental Restraint System (SRS) "AIR BAG" and "SEAT BELT PRE-TENSIONER"

INFOID:000000009726782

The Supplemental Restraint System such as "AIR BAG" and "SEAT BELT PRE-TENSIONER", used along with a front seat belt, helps to reduce the risk or severity of injury to the driver and front passenger for certain types of collision. Information necessary to service the system safely is included in the SR and SB section of this Service Manual.

WARNING:

- To avoid rendering the SRS inoperative, which could increase the risk of personal injury or death in the event of a collision which would result in air bag inflation, all maintenance must be performed by an authorized NISSAN/INFINITI dealer.
- Improper maintenance, including incorrect removal and installation of the SRS, can lead to personal injury caused by unintentional activation of the system. For removal of Spiral Cable and Air Bag Module, see the SR section.
- Do not use electrical test equipment on any circuit related to the SRS unless instructed to in this Service Manual. SRS wiring harnesses can be identified by yellow and/or orange harnesses or harness connectors.

PRECAUTIONS WHEN USING POWER TOOLS (AIR OR ELECTRIC) AND HAMMERS

WARNING:

- When working near the Airbag Diagnosis Sensor Unit or other Airbag System sensors with the Ignition ON or engine running, DO NOT use air or electric power tools or strike near the sensor(s) with a hammer. Heavy vibration could activate the sensor(s) and deploy the air bag(s), possibly causing serious injury.
- When using air or electric power tools or hammers, always switch the Ignition OFF, disconnect the battery and wait at least three minutes before performing any service.

A
B
C
D
E
F
G
H
I
J
K
L
M
SN
O
P

COMPONENT PARTS

< SYSTEM DESCRIPTION >

SYSTEM DESCRIPTION

COMPONENT PARTS

Component Parts Location

INFOID:000000009174340

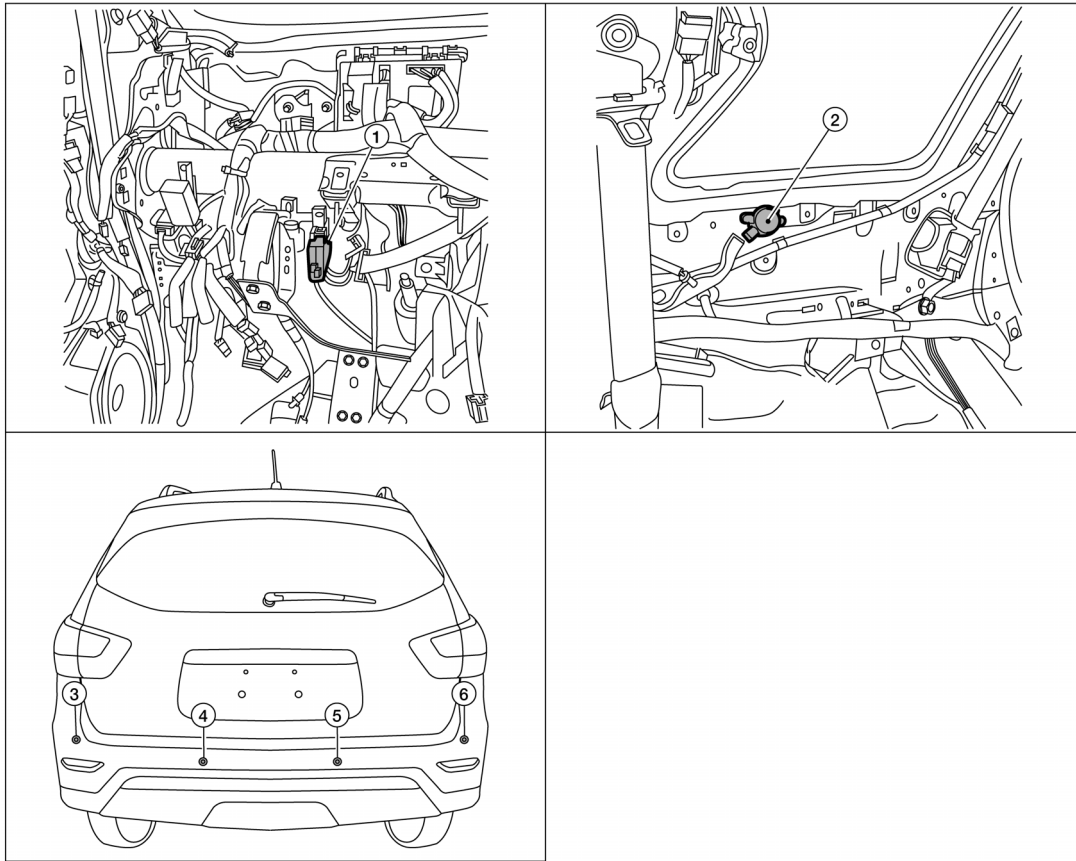

AWNIA2730ZZ

- | | | |
|------------------------------------------------------------|--------------------------------------------------------------------|-------------------------------|
| 1. Sonar control unit (view with instrument panel removed) | 2. Sonar buzzer (view with luggage side lower finisher LH removed) | 3. Rear sonar sensor LH outer |
| 4. Rear sonar sensor LH inner | 5. Rear sonar sensor RH inner | 6. Rear sonar sensor RH outer |

Component Description

INFOID:000000009174341

Component	Function
Sonar control unit	Controls sonar system and provides self-diagnosis
Sonar buzzer	Sounds a signal when objects are detected in rear of vehicle
Rear sonar sensors	Senses objects in rear of vehicle

SYSTEM

< SYSTEM DESCRIPTION >

SYSTEM

System Diagram

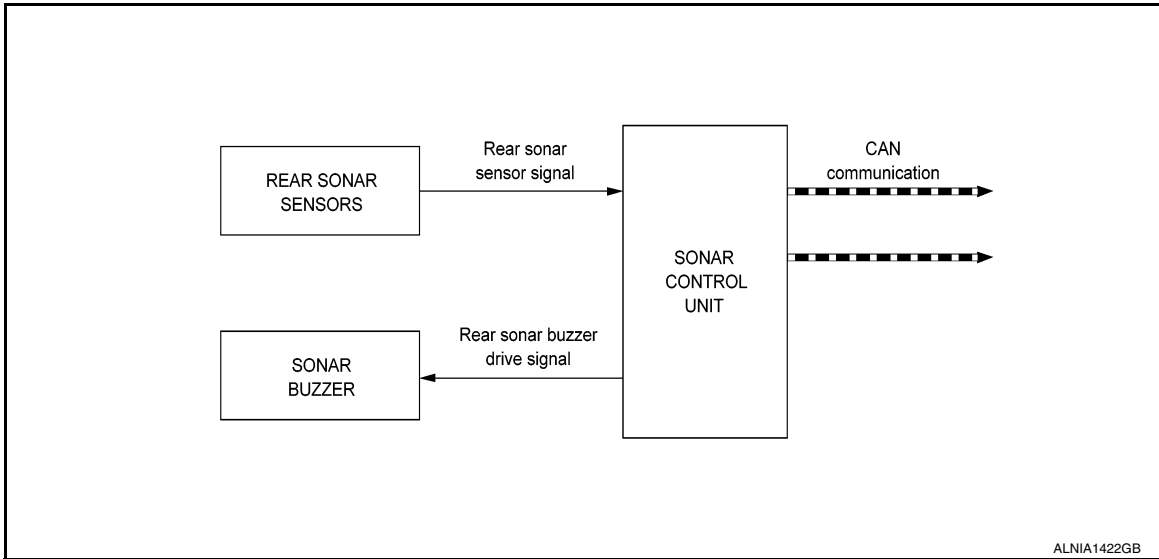

System Description

INFOID:000000009174343

SYSTEM OPERATION DESCRIPTION

- Sonar sensors transmit a sensor signal to sonar control unit when detecting an obstacle, sonar control unit converts signal into a detection distance signal and transmits it to the combination meter via CAN communication.
- Sonar control unit is capable of self diagnosis. It can detect sensor malfunction or sensor harness open circuits.

OBSTACLE DETECTION DISTANCE

- Sonar control unit changes output of sonar display and warning buzzers in 3 stages according to obstacle detection distance from corner sensors.
- Sonar control unit changes setting of obstacle detection distance in 4 stages.

A
B
C
D
E
F
G
H
I
J
K
L
M
O
P

SN

SYSTEM

< SYSTEM DESCRIPTION >

Obstacle detection image

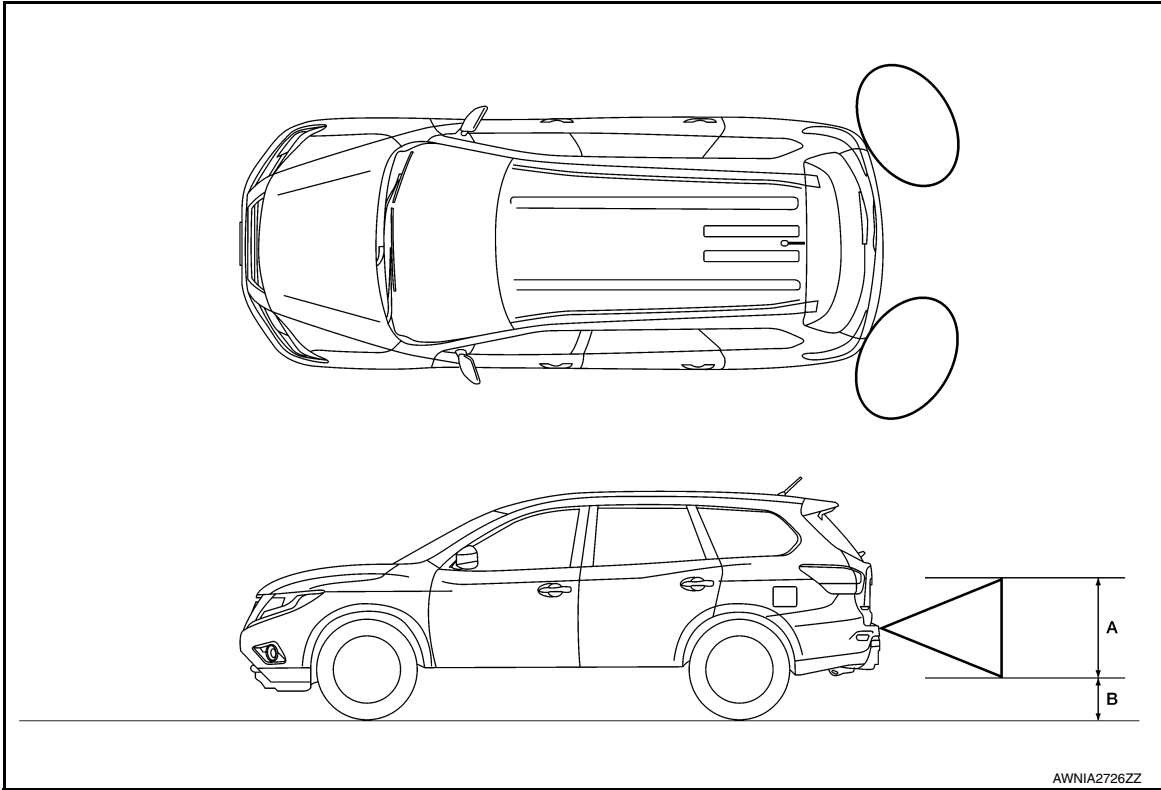

A. Approx. 50 cm (19.6 in)

B. Approx. 15 cm (5.9 in)

Detection distance

Warning item	Sensitivity level 1 (Fastest warning)	Sensitivity level 2 (Faster warning)	Sensitivity level 3 (Default value)	Sensitivity level 4 (Slower warning)
First stage warning	70 – 80 cm (27.5 – 31.4 in)	60 – 70 cm (23.6 – 27.5 in)	50 – 60 cm (19.6 – 23.6 in)	40 – 50 cm (15.7 – 19.6 in)
Second stage warning	50 – 70 cm (19.6 – 27.5 in)	40 – 60 cm (15.7 – 23.6 in)	30 – 50 cm (11.8 – 19.6 in)	30 – 40 cm (11.8 – 15.7 in)
Third stage warning	Less than 50 cm (19.6 in)	Less than 40 cm (15.7 in)	Less than 30 cm (11.8 in)	Less than 30 cm (11.8 in)

SONAR DISPLAY

- Combination meter receives detection distance signal via CAN communication from sonar control unit.
- Combination meter operates the sonar display in vehicle information display.
- Combination meter changes color and blinking cycle of display according to detection distance.

SYSTEM

< SYSTEM DESCRIPTION >

Color and blinking cycle of sonar indicator

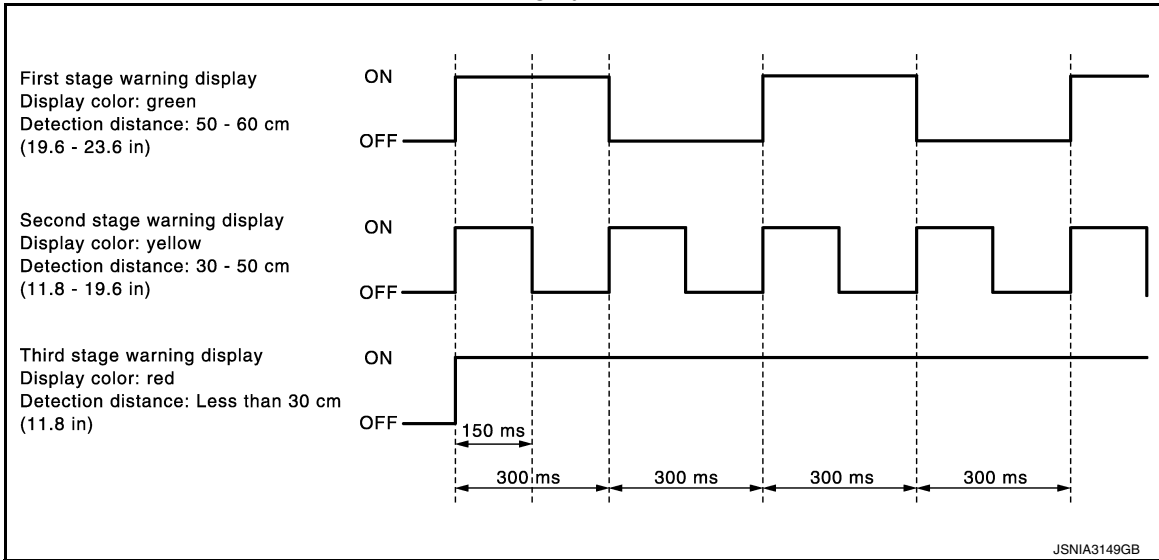

SONAR BUZZER OPERATION

- Sonar sensors transmit a sensor signal to sonar control unit when detecting an obstacle.
- Sonar control unit converts signal received from each sensor into distance and transmits detection distance signal to combination meter via CAN communication.
- Sonar control unit transmits a buzzer signal to the rear sonar buzzer.
- When a rear corner sensor detects an obstacle, rear sonar buzzer is heard.
- Sonar control unit changes buzzer cycle in 3 stages according to detection distance.

Sonar buzzer cycle

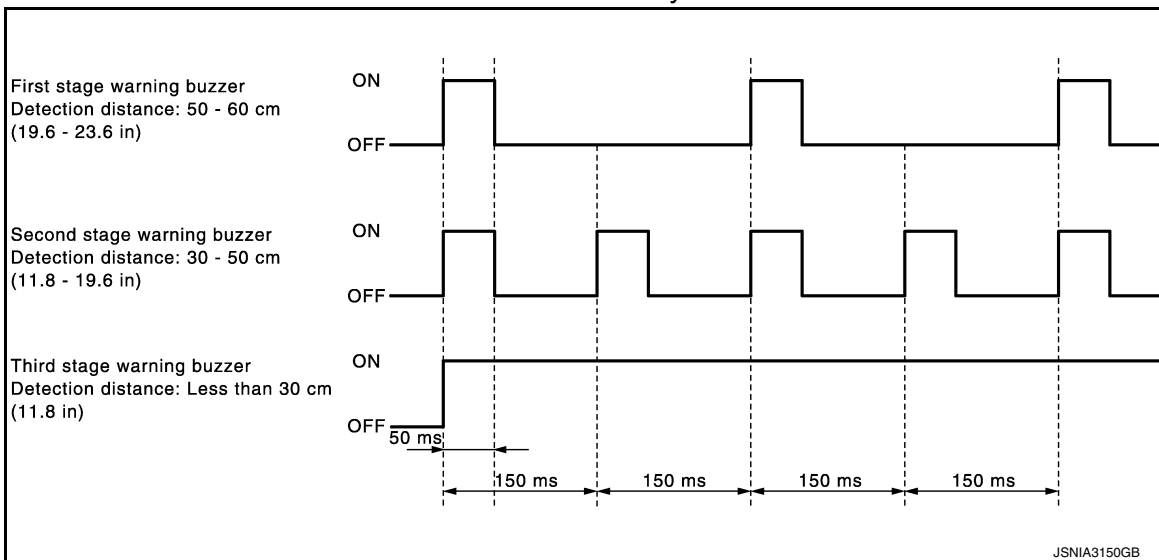

A
B
C
D
E
F
G
H
I
J
K
L
M
N
O
P

SN

DIAGNOSIS SYSTEM (SONAR CONTROL UNIT)

< SYSTEM DESCRIPTION >

DIAGNOSIS SYSTEM (SONAR CONTROL UNIT)

CONSULT Function

INFOID:000000009174344

CAUTION:

After disconnecting the CONSULT vehicle interface (VI) from the data link connector, the ignition must be cycled OFF → ON (for at least 5 seconds) → OFF. If this step is not performed, the BCM may not go to "sleep mode", potentially causing a discharged battery and no-start condition.

APPLICATION ITEMS

CONSULT can display each diagnostic item using the diagnostic test modes shown as follows:

Direct Diagnostic Mode	Description
Ecu Identification	The sonar control unit part number is displayed.
Self Diagnostic Result	The sonar control unit self diagnostic results are displayed.
Data Monitor	The sonar control unit input/output data is displayed in real time.
Active Test	The sonar control unit activates outputs to test components.
Work support	The settings for sonar control unit functions can be changed.
Configuration	<ul style="list-style-type: none">The vehicle specification can be read and saved.The vehicle specification can be written when replacing sonar control unit.
CAN Diag Support Mntr	The result of transmit/receive diagnosis of CAN communication is displayed.

ECU IDENTIFICATION

Displays the part number of sonar control unit.

SELF-DIAGNOSTIC RESULTS

For details, refer to [SN-12, "DTC Index"](#).

DATA MONITOR

Monitor Item	Description
VEHICLE SPEED [mph/km/h]	Indicates vehicle speed signal received from combination meter on CAN communication line.
SONAR C/U POWER SUPPLY [V]	Indicates condition of supply voltage signal to sonar control unit.
SENSOR VOLTAGE [V]	Indicates condition of voltage signal to sonar sensors.
DETECTION MODE [Mode 1/Mode 2]	Indicates condition of display detection mode.
SW OPRT AFTR IGN ON [Yes/No]	Indicates condition of switch operation after ignition ON signal.
SONAR TEMPORARY OFF [Yes/No]	Indicates condition of sonar system.
SONAR PERMANENT OFF [Yes/No]	Indicates condition of sonar system.
P N RANGE [On/Off]	Indicates condition of selector lever P (park) or N (neutral) position.
REVERSE RANGE [On/Off]	Indicates condition of transmission range switch R (reverse) position.
LED	Indicates condition of LED.
TRAILER CONNECT	Indicates condition of Trailer connector.
REVERSE RANGE	Indicates condition of transmission range switch R (reverse) position.

DIAGNOSIS SYSTEM (SONAR CONTROL UNIT)

< SYSTEM DESCRIPTION >

Monitor Item	Description	
SHRT DST FRM RR SENS [cm/in]	Indicates distance to obstacle.	A
COR[RL] [cm/in]		B
COR[RL]→ CEN[RL]/CEN[R] [cm/in]		C
CEN[RL]/CEN[R]→ COR[RL] [cm/in]		D
CEN[RL]/CEN[R] [cm/in]		E
CEN[RL]→ CEN[RR] [cm/in]		F
CEN[RR]→ CEN[RL] [cm/in]		G
CEN[RR] [cm/in]		H
CEN[RR]/CEN[R]→ COR[RR] [cm/in]		I
COR[RR]→ CEN[RR]/CEN[R] [cm/in]		J
COR[RR] [cm/in]		K
RVRB TIME COR[RL] [ms/sec]		L
RVRB TIME COR[RR] [ms/sec]		M
RVRB TIME CEN [RL] [ms/sec]		N
RVRB TIME CEN [RR] ms/sec]		O

ACTIVE TEST

Test Item	Description	
REAR BUZZER	This test is able to check rear buzzer operation [On/Off].	P

WORK SUPPORT

Support Item	Setting	Description	
VOLUME SETTING	Vol.1	Allows you to set volume of warning tone.	Q
	Low		R
	Vol.3		S
	Middle		T
	Vol.5		U
	High		V
	Off		W
TRAILER HITCH DETECTION RANGE ADJUSTMENT	Qu	Allows you to adjust rear sonar sensors for trailer towing.	X
	UP		Y
	DOWN		Z
	Qd		AA

CONFIGURATION

Refer to [SN-21, "CONFIGURATION \(SONAR CONTROL UNIT\) : Description"](#).

CAN DIAG SUPPORT MNTR

Refer to [LAN-17, "CAN Diagnostic Support Monitor"](#).

SONAR CONTROL UNIT

< ECU DIAGNOSIS INFORMATION >

ECU DIAGNOSIS INFORMATION

SONAR CONTROL UNIT

Reference Value

INFOID:000000009174345

VALUES ON THE DIAGNOSIS TOOL

Monitor Item	Condition	Value/Status
VEHICLE SPEED	While driving, equivalent to speedometer reading	mph, km/h
SONAR C/U POWER SUPPLY	Key ON.	Battery voltage
SENSOR VOLTAGE	Key ON, selector lever in R (reverse) position.	5.0 V
DETECTION MODE	Key ON.	Mode 1
		Mode 2
SONAR TEMPORARY OFF	Key ON, selector lever in R (reverse) position.	No
	When selector lever is in any position other than R (reverse).	Yes
SONAR PERMANENT OFF	Key ON, selector lever in R (reverse) position.	No
	When selector lever is in any position other than R (reverse).	Yes
LED	When LED is OFF.	Off
	When LED is ON.	On
TRAILER CONNECT	No trailer connected to trailer hitch.	N CON
	Trailer connected to trailer hitch.	CON
COR[RL]→CEN[RL]/CEN[R]	Key ON, selector lever in R (reverse) position.	cm/in
CEN[RL]/CEN[R]→COR[RL]		
CEN[RL]/CEN[R]		
CEN[RL]→CEN[RR]		
CEN[RR]→CEN[RL]		
CEN[RR]/CEN[R]→COR[RR]		
COR[RR]→CEN[RR]/CEN[R]		
COR[RL]		
COR[RR]		
CEN[RL]		
CEN[RR]		
P N RANGE		
	When selector lever in P (park) or N (neutral) position.	On
REVERSE RANGE	When transmission range switch is in any position other than R (reverse).	Off
	When transmission range switch is in R (reverse) position.	On
RVRB TIME COR[RL]	Key ON, selector lever in R (reverse) position.	ms/sec
RVRB TIME COR[RR]		
RVRB TIME CEN[RL]		
RVRB TIME CEN[RR]		
SHRT DST FRM RR SENS		

SONAR CONTROL UNIT

< ECU DIAGNOSIS INFORMATION >

TERMINAL LAYOUT

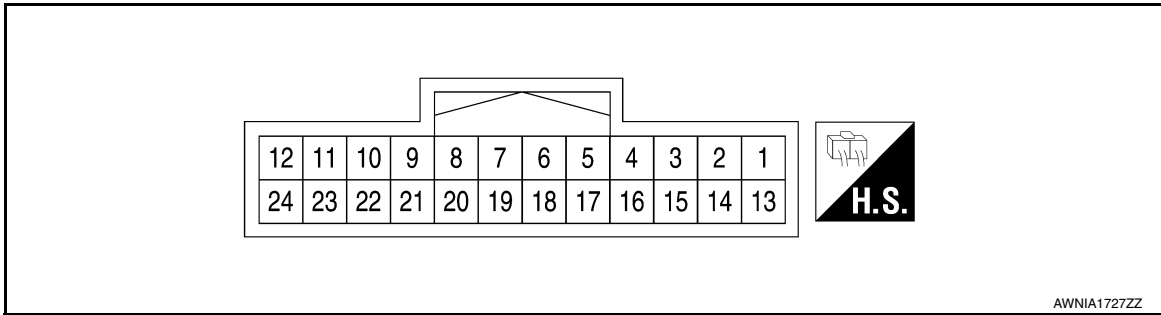

PHYSICAL VALUES

Terminal (Wire color)		Description		Condition		Reference value (Approx.)
+	-	Signal name	Input/ Output	Ignition switch	Operation	
5 (B)	—	CAN (H)	Input/ Output	—	—	—
6 (W)	—	CAN (L)	Input/ Output	—	—	—
9 (W)	14 (B)	Rear sonar sensor RH inner	Input	ON	Shift position is R (reverse). Obstacle within range of rear sonar sensor RH inner.	 JSNIA0837GB
10 (W)	14 (B)	Rear sonar sensor RH outer	Input	ON	Shift position is R (reverse). Obstacle within range of rear sonar sensor RH outer.	 JSNIA0837GB
12 (LG)	Ground	IGN power supply	Input	ON	—	Battery voltage
14 (B)	Ground	Rear sensor ground	—	ON	—	0 V
15 (GR)	Ground	Ground	—	ON	—	0 V
19 (BR)	Ground	Buzzer power supply	Output	ON	—	Battery voltage
20 (LG)	Ground	Rear buzzer signal	Output	ON	Shift position is R (reverse). Obstacle within range of a rear sonar sensor.	Battery voltage

SONAR CONTROL UNIT

< ECU DIAGNOSIS INFORMATION >

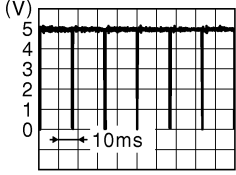
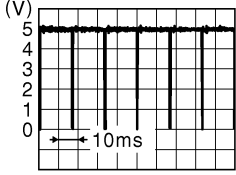
Terminal (Wire color)		Description		Condition		Reference value (Approx.)
+	-	Signal name	Input/ Output	Ignition switch	Operation	
21 (W)	14 (B)	Rear sonar sensor LH inner	Input	ON	Shift position is R (reverse). Obstacle within range of rear sonar sensor LH inner.	 <p style="text-align: right; font-size: small;">JSNIA0837GB</p>
22 (W)	14 (B)	Rear sonar sensor LH outer	Input	ON	Shift position is R (reverse). Obstacle within range of rear sonar sensor LH outer.	 <p style="text-align: right; font-size: small;">JSNIA0837GB</p>

DTC Index

INFOID:000000009174346

CONSULT Display	Reference Page
U1000: CAN COMM CIRCUIT	SN-23, "DTC Logic"
U1010: CONTROL UNIT (CAN)	SN-24, "DTC Logic"
B2720: REAR LEFT SIDE EXTERNAL SENSOR	SN-25, "DTC Logic"
B2721: REAR LEFT SIDE INTERNAL SENSOR	SN-26, "DTC Logic"
B2722: REAR RIGHT SIDE INTERNAL SENSOR	SN-27, "DTC Logic"
B2723: REAR RIGHT SIDE EXTERNAL SENSOR	SN-28, "DTC Logic"
B2724: ECU	SN-29, "DTC Logic"
B2725: REAR BUZZER	SN-30, "DTC Logic"

SONAR SYSTEM

< WIRING DIAGRAM >

WIRING DIAGRAM

SONAR SYSTEM

Wiring Diagram

INFOID:000000009174347

SONAR SYSTEM

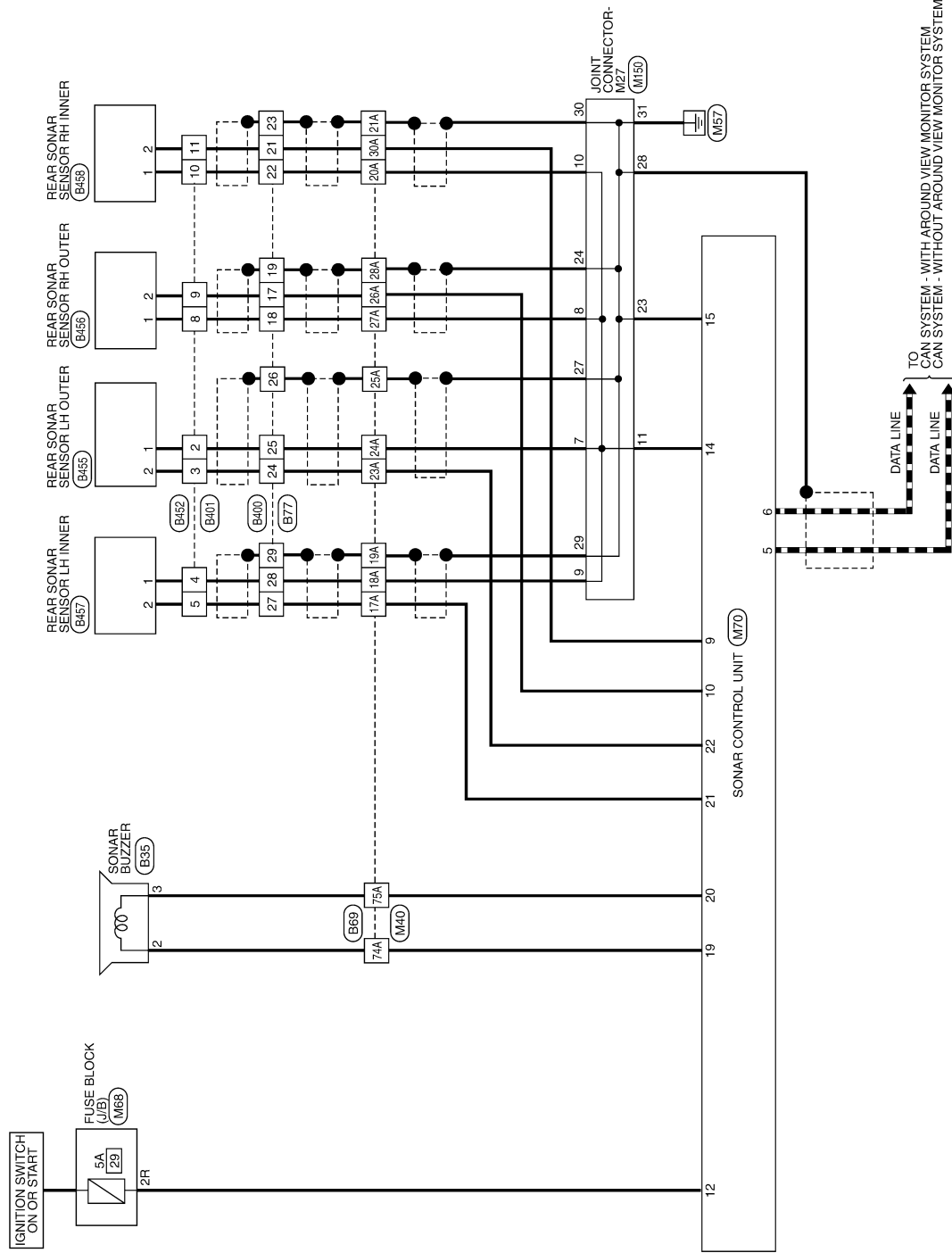

A
B
C
D
E
F
G
H
I
J
K
L
M
N
O
P

SN

ABNWA1827GB

SONAR SYSTEM CONNECTORS

Connector No.	M40
Connector Name	WIRE TO WIRE
Connector Color	GRAY

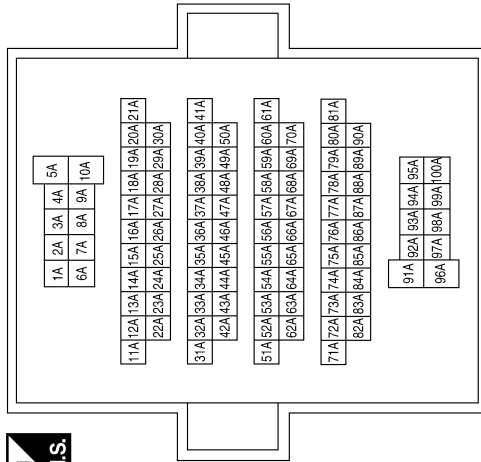

Terminal No.	Color of Wire	Signal Name
17A	W	-
18A	B	-
19A	SHIELD	-
20A	B	-
21A	SHIELD	-
23A	W	-
24A	B	-
25A	SHIELD	-
26A	W	-
27A	B	-
28A	SHIELD	-
30A	W	-
74A	BR	-
75A	LG	-

Connector No.	M68
Connector Name	FUSE BLOCK (J/B)
Connector Color	BROWN



Terminal No.	Color of Wire	Signal Name
2R	LG	-

Connector No.	M70
Connector Name	SONAR CONTROL UNIT
Connector Color	WHITE

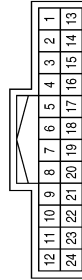

Terminal No.	Color of Wire	Signal Name
1	-	-
2	-	-
3	-	-
4	-	-

Terminal No.	Color of Wire	Signal Name
5	B	CAN-H
6	W	CAN-L
7	-	-
8	-	-
9	W	RIR SENSOR SIGNAL
10	W	ROR SENSOR SIGNAL
11	-	-
12	LG	IGN
13	-	-
14	B	RR SENSOR GND
15	GR	GND

Terminal No.	Color of Wire	Signal Name
16	-	-
17	-	-
18	-	-
19	BR	SPEAKER PWR
20	LG	SPEAKER RR SIGNAL
21	W	RIL SENSOR SIGNAL
22	W	ROL SENSOR SIGNAL
23	-	-
24	-	-

ABNIA4743GB

SONAR SYSTEM

< WIRING DIAGRAM >

Connector No.	B35
Connector Name	SONAR BUZZER
Connector Color	WHITE

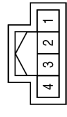

Terminal No.	Color of Wire	Signal Name
1	-	-
2	P	-
3	V	-
4	-	-

Terminal No.	Color of Wire	Signal Name
9	B	-
10	B	-
11	B	-
23	GR	-
24	SHIELD	-
27	SHIELD	-
28	SHIELD	-
29	SHIELD	-
30	SHIELD	-
31	GR	-

Connector No.	M150
Connector Name	JOINT CONNECTOR-M27
Connector Color	WHITE

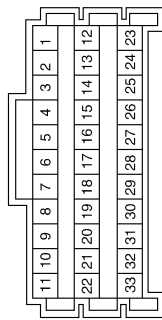

Terminal No.	Color of Wire	Signal Name
7	B	-
8	B	-

Connector No.	B77
Connector Name	WIRE TO WIRE
Connector Color	WHITE

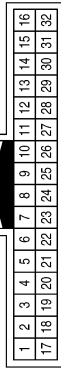

Terminal No.	Color of Wire	Signal Name
17	W	-
18	B	-
19	SHIELD	-
21	B	-
22	W	-
23	SHIELD	-
24	W	-
25	B	-
26	SHIELD	-
27	W	-
28	B	-
29	SHIELD	-

Terminal No.	Color of Wire	Signal Name
17A	W	-
18A	B	-
19A	SHIELD	-
20A	W	-
21A	SHIELD	-
23A	W	-
24A	B	-
25A	SHIELD	-
26A	W	-
27A	B	-
28A	SHIELD	-
30A	B	-
74A	P	-
75A	V	-

Connector No.	B69
Connector Name	WIRE TO WIRE
Connector Color	GRAY

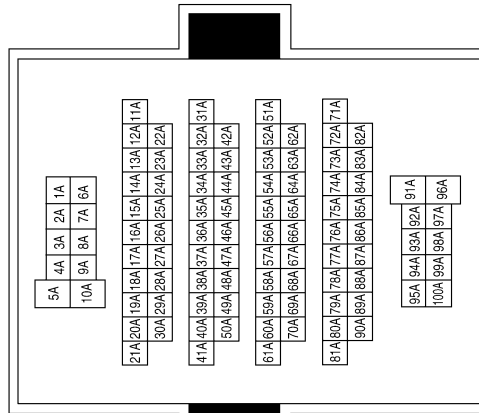

ABNIA4744GB

A
B
C
D
E
F
G
H
I
J
K
L
M
N
O
P



SONAR SYSTEM

< WIRING DIAGRAM >

Connector No.	B401
Connector Name	WIRE TO WIRE
Connector Color	BLACK

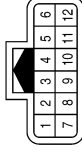

Terminal No.	Color of Wire	Signal Name
2	B	-
3	W	-
4	B	-
5	W	-
8	B	-
9	W	-
10	W	-
11	B	-

Terminal No.	Color of Wire	Signal Name
22	W	-
23	SHIELD	-
24	W	-
25	B	-
26	SHIELD	-
27	W	-
28	B	-
29	SHIELD	-

Connector No.	B400
Connector Name	WIRE TO WIRE
Connector Color	WHITE

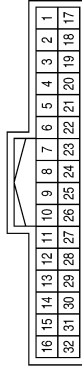

Terminal No.	Color of Wire	Signal Name
17	W	-
18	B	-
19	SHIELD	-
21	B	-

Connector No.	B456
Connector Name	REAR SONAR SENSOR RH OUTER
Connector Color	BLACK



Terminal No.	Color of Wire	Signal Name
1	L	-
2	W	-
3	-	-

Connector No.	B455
Connector Name	REAR SONAR SENSOR LH OUTER
Connector Color	BLACK



Terminal No.	Color of Wire	Signal Name
1	P	-
2	G	-
3	-	-

Connector No.	B452
Connector Name	WIRE TO WIRE
Connector Color	BLACK

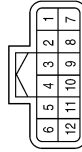

Terminal No.	Color of Wire	Signal Name
2	P	-
3	G	-
4	L	-
5	Y	-
8	L	-
9	W	-
10	P	-
11	G	-

ABNIA4844GB

SONAR SYSTEM

< WIRING DIAGRAM >

A
B
C
D
E
F
G
H
I
J
K
L
M
SN
O
P

Connector No.	B458
Connector Name	REAR SONAR SENSOR RH INNER
Connector Color	BLACK



Terminal No.	Color of Wire	Signal Name
1	P	-
2	G	-
3	-	-

Connector No.	B457
Connector Name	REAR SONAR SENSOR LH INNER
Connector Color	BLACK



Terminal No.	Color of Wire	Signal Name
1	L	-
2	Y	-
3	-	-

ABNIA4845GB

DIAGNOSIS AND REPAIR WORKFLOW

< BASIC INSPECTION >

BASIC INSPECTION

DIAGNOSIS AND REPAIR WORKFLOW

Work Flow

INFOID:000000009174348

OVERALL SEQUENCE

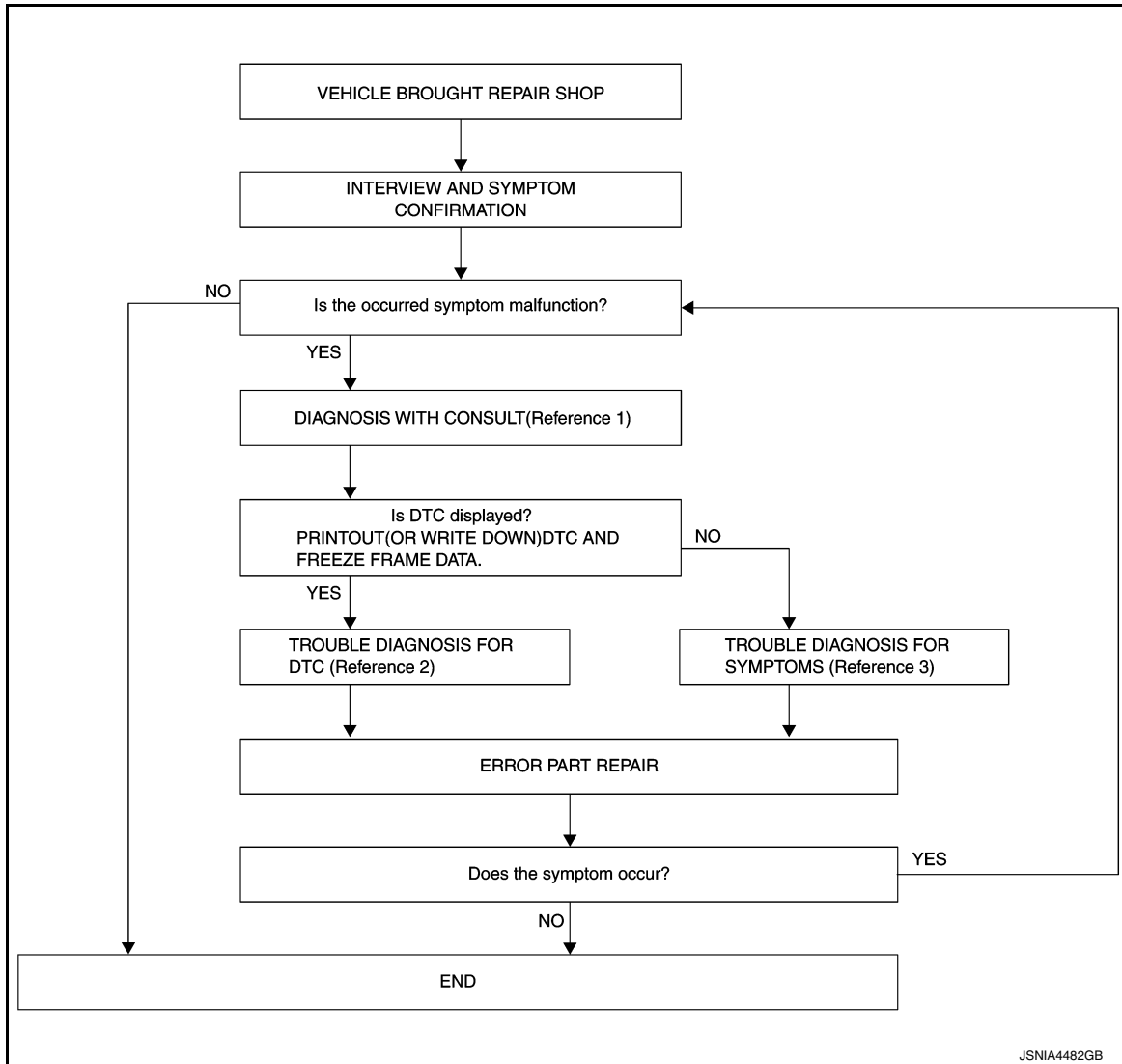

Reference 1: Refer to [SN-8. "CONSULT Function"](#).

Reference 2: Refer to [SN-12. "DTC Index"](#).

Reference 3: Refer to [SN-33. "Symptom Table"](#).

DETAILED FLOW

1. INTERVIEW AND SYMPTOM CONFIRMATION

Check the malfunction symptoms by performing the following items.

- Interview the customer to obtain the malfunction information (conditions and environment when the malfunction occurred).
- Check the symptom.

Is the occurred symptom malfunction?

YES >> GO TO 2.

NO >> Inspection End.

2. DIAGNOSIS WITH CONSULT

1. Connect CONSULT and perform Self Diagnostic Result for SONAR. Refer to [SN-8. "CONSULT Function"](#).

NOTE:

DIAGNOSIS AND REPAIR WORKFLOW

< BASIC INSPECTION >

Skip to step 4 of the diagnosis procedure if SONAR is not displayed.

2. When DTC is detected, follow the instructions below:
 - Record DTC and Freeze Frame Data.

Is DTC displayed?

- YES >> GO TO 3.
NO >> GO TO 4.

3. TROUBLE DIAGNOSIS FOR DTC

1. Check the DTC indicated in the self-diagnosis results.
2. Perform the relevant diagnosis referring to the DTC Index. Refer to [SN-12, "DTC Index"](#).

>> GO TO 5.

4. TROUBLE DIAGNOSIS FOR SYMPTOMS

Perform the relevant diagnosis referring to the diagnosis chart by symptom. Refer to [SN-33, "Symptom Table"](#).

>> GO TO 5.

5. ERROR PART REPAIR

1. Repair or replace the identified malfunctioning parts.
2. Perform Self Diagnostic Result for SONAR with CONSULT.

NOTE:

Erase the stored self-diagnosis results after repairing or replacing the relevant components if any DTC has been indicated in the self-diagnosis results.

3. Check that the symptom does not occur.

Does the symptom occur?

- YES >> GO TO 1.
NO >> Inspection End.

A
B
C
D
E
F
G
H
I
J
K
L
M
O
P

SN

INSPECTION AND ADJUSTMENT

< BASIC INSPECTION >

INSPECTION AND ADJUSTMENT

ADDITIONAL SERVICE WHEN REPLACING SONAR CONTROL UNIT

ADDITIONAL SERVICE WHEN REPLACING SONAR CONTROL UNIT : Description

INFOID:000000009174349

BEFORE REPLACEMENT

When replacing sonar control unit, save or print current vehicle specification with CONSULT configuration before replacement.

NOTE:

If "Before Replace ECU" cannot be used, use the "After Replace ECU" or "Manual Configuration" after replacing sonar control unit.

AFTER REPLACEMENT

CAUTION:

When replacing sonar control unit, you must perform "After Replace ECU" with CONSULT.

- Complete the procedure of "After Replace ECU" in order.
- If you set incorrect "After Replace ECU", incidents might occur.
- Configuration is different for each vehicle model. Confirm configuration of each vehicle model.

ADDITIONAL SERVICE WHEN REPLACING SONAR CONTROL UNIT : Work Procedure

INFOID:000000009174350

1. SAVING VEHICLE SPECIFICATION

Ⓜ-CONSULT

Enter "Re/Programming, Configuration" and perform "Before Replace ECU" to save or print current vehicle specification.

NOTE:

If "Before Replace ECU" cannot be used, use the "After Replace ECU" or "Manual Configuration" after replacing sonar control unit.

>> GO TO 2.

2. REPLACE SONAR CONTROL UNIT

Replace sonar control unit. Refer to [SN-34. "Removal and Installation"](#).

>> GO TO 3.

3. WRITING VEHICLE SPECIFICATION

ⓂCONSULT

1. Enter "Re/Programming, Configuration".
2. If "Before Replace ECU" operation was performed, an "Operation Log Selection" screen will automatically be displayed. Select the applicable file from the "Saved Data List" and press "Confirm" to write vehicle specification. Refer to [SN-21. "CONFIGURATION \(SONAR CONTROL UNIT\) : Work Procedure"](#).
3. If "Before Replace ECU" operation was not performed, select "After Replace ECU" or "Manual Configuration" to write vehicle specification. Refer to [SN-21. "CONFIGURATION \(SONAR CONTROL UNIT\) : Work Procedure"](#).

>> GO TO 4.

4. OPERATION CHECK

Check that the operation of the sonar control unit is normal.

>> Work End.

CONFIGURATION (SONAR CONTROL UNIT)

INSPECTION AND ADJUSTMENT

< BASIC INSPECTION >

CONFIGURATION (SONAR CONTROL UNIT) : Description

INFOID:000000009174351

Vehicle specification needs to be written with CONSULT. Configuration has three functions as follows:

Function	Description
"Before Replace ECU"	<ul style="list-style-type: none">• Reads the vehicle configuration of current sonar control unit.• Saves the read vehicle configuration.
"After Replace ECU"	Writes the vehicle configuration with manual selection.
"Select Saved Data List"	Writes the vehicle configuration with saved data.

CAUTION:

- When replacing sonar control unit, you must perform "Select Saved Data List" or "After Replace ECU" with CONSULT.
- Complete the procedure of "Select Saved Data List" or "After Replace ECU" in order.
- If you set incorrect "Select Saved Data List" or "After Replace ECU", incidents might occur.
- Configuration is different for each vehicle model. Confirm configuration of each vehicle model.
- Never perform "Select Saved Data List" or "After Replace ECU" except for new sonar control unit.

CONFIGURATION (SONAR CONTROL UNIT) : Work Procedure

INFOID:000000009174352

1. WRITING MODE SELECTION

CONSULT

Select "Reprogramming, Configuration" of sonar control unit.

When writing saved data>>GO TO 2.

When writing manually>>GO TO 3.

2. PERFORM "SAVED DATA LIST"

CONSULT

Automatically "Operation Log Selection" window will display if "Before Replace ECU" was performed. Select applicable file from the "Save Data List" and press "Confirm".

>> Work End.

3. PERFORM "AFTER REPLACE ECU" OR "MANUAL CONFIGURATION"

CONSULT

1. Select "After Replace ECU" or "Manual Configuration".
2. Identify the correct model and configuration list. Refer to [SN-22. "CONFIGURATION \(SONAR CONTROL UNIT\) : Configuration List"](#).
3. Confirm and/or change setting value for each item.

CAUTION:

Thoroughly read and understand the vehicle specification. ECU control may not operate normally if the setting is not correct.

4. Select "Next".

CAUTION:

Make sure to select "Next", confirm each setting value and press "OK" even if the indicated configuration of brand new sonar control unit is same as the desirable configuration. If not, configuration which is set automatically by selecting vehicle model can not be memorized.

5. When "Completed", select "End".

>> GO TO 4.

4. OPERATION CHECK

Confirm that each function controlled by sonar control unit operates normally.

>> Work End.

INSPECTION AND ADJUSTMENT

< BASIC INSPECTION >

CONFIGURATION (SONAR CONTROL UNIT) : Configuration List

INFOID:000000009174353

CAUTION:

Thoroughly read and understand the vehicle specification. Incorrect settings may result in abnormal control of ECU.

MANUAL SETTING ITEM	
Items	Setting value
BCI FUNCTION	WITH ⇔ WITHOUT*

⇔: Items which confirm vehicle specifications

*: BCI FUNCTION should always be set to WITHOUT.

U1000 CAN COMM CIRCUIT

< DTC/CIRCUIT DIAGNOSIS >

DTC/CIRCUIT DIAGNOSIS

U1000 CAN COMM CIRCUIT

DTC Logic

INFOID:000000009174354

DTC DETECTION LOGIC

CONSULT Display	DTC Detection Condition	Possible Cause
CAN COMM CIRCUIT [U1000]	Sonar control unit is not transmitting or receiving CAN communication signal for 2 seconds or more.	CAN communication system.

Diagnosis Procedure

INFOID:000000009174355

1. PERFORM SELF DIAGNOSTIC RESULT

1. Turn ignition switch ON and wait for 2 seconds or more.
2. Perform Self Diagnostic Result for SONAR.

Is CAN COMM CIRCUIT displayed?

- YES >> Refer to [LAN-20, "Trouble Diagnosis Flow Chart"](#).
NO >> Refer to [GI-49, "Intermittent Incident"](#).

A
B
C
D
E
F
G
H
I
J
K
L
M
O
P

SN

U1010 CONTROL UNIT (CAN)

< DTC/CIRCUIT DIAGNOSIS >

U1010 CONTROL UNIT (CAN)

DTC Logic

INFOID:000000009174356

DTC DETECTION LOGIC

CONSULT Display	DTC Detection Condition	Possible Cause
CONTROL UNIT (CAN) [U1010]	CAN initial diagnosis malfunction is detected.	Replace the sonar control unit if the malfunction occurs constantly. Refer to SN-34, "Removal and Installation" .

B2720 CORNER SENSOR [RL]

< DTC/CIRCUIT DIAGNOSIS >

B2720 CORNER SENSOR [RL]

DTC Logic

INFOID:000000009174357

DTC DETECTION LOGIC

CONSULT Display	DTC Detection Condition	Possible Cause
REAR LEFT SIDE EXTERNAL SENSOR [B2720]	<ul style="list-style-type: none"> • Sensor is not configured. • Sensor is open or short circuited. • Sensor element malfunction. 	<ul style="list-style-type: none"> • Sensor configuration. • Harness or connectors. • Rear sonar sensor LH outer.

Diagnosis Procedure

INFOID:000000009174358

Regarding Wiring Diagram information, refer to [SN-13. "Wiring Diagram"](#).

1. CHECK REAR SONAR SENSOR LH OUTER CIRCUIT CONTINUITY

1. Turn ignition switch OFF.
2. Disconnect sonar control unit connector and rear sonar sensor LH outer connector.
3. Check continuity between sonar control unit connector M70 and rear sonar sensor LH outer connector B455.

Sonar control unit		Rear sonar sensor LH outer		Continuity
Connector	Terminal	Connector	Terminal	
M70	22	B455	2	Yes
	14		1	

4. Check continuity between sonar control unit connector M70 and ground.

Sonar control unit		Ground	Continuity
Connector	Terminal		
M70	22	—	No

Is the inspection result normal?

- YES >> GO TO 2.
 NO >> Repair or replace harness or connectors.

2. CHECK REAR SONAR SENSOR LH OUTER SIGNAL CIRCUIT SHORT TO BATTERY

1. Turn ignition switch ON.
2. Check voltage between sonar control unit connector M70 and ground.

Sonar control unit		Ground	Voltage (Approx.)
Connector	Terminal		
M70	22	—	0V

Is the inspection result normal?

- YES >> Replace rear sonar sensor LH outer. Refer to [SN-35. "Removal and Installation"](#).
 NO >> Repair or replace harness or connectors.

B2721 CENTER SENSOR [RL]

< DTC/CIRCUIT DIAGNOSIS >

B2721 CENTER SENSOR [RL]

DTC Logic

INFOID:000000009174359

DTC DETECTION LOGIC

CONSULT Display	DTC Detection Condition	Possible Cause
REAR LEFT SIDE INTER-NAL SENSOR [B2721]	<ul style="list-style-type: none">• Sensor is not configured.• Sensor is open or short circuited.• Sensor element malfunction.	<ul style="list-style-type: none">• Sensor configuration.• Harness or connectors.• Rear sonar sensor LH inner.

Diagnosis Procedure

INFOID:000000009174360

Regarding Wiring Diagram information, refer to [SN-13. "Wiring Diagram"](#).

1. CHECK REAR SONAR SENSOR LH INNER CIRCUIT CONTINUITY

1. Turn ignition switch OFF.
2. Disconnect sonar control unit connector and rear sonar sensor LH inner connector.
3. Check continuity between sonar control unit connector M70 and rear sonar sensor LH inner connector B457.

Sonar control unit		Rear sonar sensor LH inner		Continuity
Connector	Terminal	Connector	Terminal	
M70	21	B457	2	Yes
	14		1	

4. Check continuity between sonar control unit connector M70 and ground.

Sonar control unit		Ground	Continuity
Connector	Terminal		
M70	21	—	No

Is the inspection result normal?

YES >> GO TO 2.

NO >> Repair or replace harness or connectors.

2. CHECK REAR SONAR SENSOR LH INNER SIGNAL CIRCUIT SHORT TO BATTERY

1. Turn ignition switch ON.
2. Check voltage between sonar control unit connector M70 and ground.

Sonar control unit		Ground	Voltage (Approx.)
Connector	Terminal		
M70	21	—	0V

Is the inspection result normal?

YES >> Replace rear sonar sensor LH inner. Refer to [SN-35. "Removal and Installation"](#).

NO >> Repair or replace harness or connectors.

B2722 CENTER SENSOR [RR]

< DTC/CIRCUIT DIAGNOSIS >

B2722 CENTER SENSOR [RR]

DTC Logic

INFOID:000000009174361

DTC DETECTION LOGIC

CONSULT Display	DTC Detection Condition	Possible Cause
REAR RIGHT SIDE INTER-NAL SENSOR [B2722]	<ul style="list-style-type: none">• Sensor is not configured.• Sensor is open or short circuited.• Sensor element malfunction.	<ul style="list-style-type: none">• Sensor configuration.• Harness or connectors.• Rear sonar sensor RH inner.

Diagnosis Procedure

INFOID:000000009174362

Regarding Wiring Diagram information, refer to [SN-13. "Wiring Diagram"](#).

1. CHECK REAR SONAR SENSOR RH INNER CIRCUIT CONTINUITY

1. Turn ignition switch OFF.
2. Disconnect sonar control unit connector and rear sonar sensor RH inner connector.
3. Check continuity between sonar control unit connector M70 and rear sonar sensor RH inner connector B458.

Sonar control unit		Rear sonar sensor RH inner		Continuity
Connector	Terminal	Connector	Terminal	
M70	9	B458	2	Yes
	14		1	

4. Check continuity between sonar control unit connector M70 and ground.

Sonar control unit		Ground	Continuity
Connector	Terminal		
M70	9	—	No

Is the inspection result normal?

- YES >> GO TO 2.
NO >> Repair or replace harness or connectors.

2. CHECK REAR SONAR SENSOR RH INNER SIGNAL CIRCUIT SHORT TO BATTERY

1. Turn ignition switch ON.
2. Check voltage between sonar control unit connector M70 and ground.

Sonar control unit		Ground	Voltage (Approx.)
Connector	Terminal		
M70	9	—	0V

Is the inspection result normal?

- YES >> Replace rear sonar sensor RH inner. Refer to [SN-35. "Removal and Installation"](#).
NO >> Repair or replace harness or connectors.

B2723 CORNER SENSOR [RR]

< DTC/CIRCUIT DIAGNOSIS >

B2723 CORNER SENSOR [RR]

DTC Logic

INFOID:000000009174363

DTC DETECTION LOGIC

CONSULT Display	DTC Detection Condition	Possible Cause
REAR RIGHT SIDE EXTERNAL SENSOR [B2723]	<ul style="list-style-type: none">• Sensor is not configured.• Sensor is open or short circuited.• Sensor element malfunction.	<ul style="list-style-type: none">• Sensor configuration.• Harness or connectors.• Rear sonar sensor RH outer.

Diagnosis Procedure

INFOID:000000009174364

Regarding Wiring Diagram information, refer to [SN-13. "Wiring Diagram"](#).

1. CHECK REAR SONAR SENSOR RH OUTER SIGNAL CIRCUIT CONTINUITY

1. Turn ignition switch OFF.
2. Disconnect sonar control unit connector and rear sonar sensor RH outer connector.
3. Check continuity between sonar control unit connector M70 and rear sonar sensor RH outer connector B456.

Sonar control unit		Rear sonar sensor RH outer		Continuity
Connector	Terminal	Connector	Terminal	
M70	10	B456	2	Yes
	14		1	

4. Check continuity between sonar control unit connector M70 and ground.

Sonar control unit		Ground	Continuity
Connector	Terminal		
M70	10	—	No

Is the inspection result normal?

YES >> GO TO 2.

NO >> Repair or replace harness or connectors.

2. CHECK REAR SONAR SENSOR RH OUTER SIGNAL CIRCUIT SHORT TO BATTERY

1. Turn ignition switch ON.
2. Check voltage between sonar control unit connector M70 and ground.

Sonar control unit		Ground	Voltage (Approx.)
Connector	Terminal		
M70	10	—	0V

Is the inspection result normal?

YES >> Replace rear sonar sensor RH outer. Refer to [SN-35. "Removal and Installation"](#).

NO >> Repair or replace harness or connectors.

B2724 SONAR CONTROL UNIT

< DTC/CIRCUIT DIAGNOSIS >

B2724 SONAR CONTROL UNIT

DTC Logic

INFOID:000000009174365

DTC DETECTION LOGIC

CONSULT Display	DTC Detection Condition	Possible Cause
ECU [B2724]	Sonar control unit malfunction.	Replace sonar control unit. Refer to SN-34, "Removal and Installation" .

A

B

C

D

E

F

G

H

I

J

K

L

M

SN

O

P

B2725 REAR BUZZER

< DTC/CIRCUIT DIAGNOSIS >

B2725 REAR BUZZER

DTC Logic

INFOID:000000009174366

DTC DETECTION LOGIC

CONSULT Display	DTC Detection Condition	Possible Cause
REAR BUZZER [B2725]	<ul style="list-style-type: none">• Rear buzzer is open or short circuited.• Rear buzzer malfunction.	<ul style="list-style-type: none">• Harness or connectors.• Sonar buzzer.

Diagnosis Procedure

INFOID:000000009174367

Regarding Wiring Diagram information, refer to [SN-13, "Wiring Diagram"](#).

1. CHECK SONAR BUZZER SIGNAL CIRCUIT CONTINUITY

1. Turn ignition switch OFF.
2. Disconnect sonar control unit connector and sonar buzzer connector.
3. Check continuity between sonar control unit connector M70 and sonar buzzer connector B35.

Sonar control unit		Sonar buzzer		Continuity
Connector	Terminal	Connector	Terminal	
M70	20	B35	3	Yes

4. Check continuity between sonar control unit connector M70 and ground.

Sonar control unit		Ground	Continuity
Connector	Terminal		
M70	20	—	No

Is the inspection result normal?

- YES >> GO TO 2.
NO >> Repair or replace harness or connectors.

2. CHECK SONAR BUZZER SIGNAL CIRCUIT SHORT TO BATTERY

1. Turn ignition switch ON.
2. Check voltage between sonar control unit connector M70 and ground.

Sonar control unit		Ground	Voltage (Approx.)
Connector	Terminal		
M70	20	—	0V

Is the inspection result normal?

- YES >> GO TO 3.
NO >> Repair or replace harness or connectors.

3. CHECK SONAR BUZZER SIGNAL CIRCUIT SHORT TO BUZZER POWER

1. Turn ignition switch OFF.
2. Check continuity between sonar control unit connector M70 terminals.

Sonar control unit connector M48		Continuity
Terminal	Terminal	
19	20	No

Is the inspection result normal?

B2725 REAR BUZZER

< DTC/CIRCUIT DIAGNOSIS >

YES >> Replace sonar buzzer. Refer to [SN-36. "Removal and Installation"](#).
NO >> Repair or replace harness or connectors.

A

B

C

D

E

F

G

H

I

J

K

L

M

SN

O

P

POWER SUPPLY AND GROUND CIRCUIT

< DTC/CIRCUIT DIAGNOSIS >

POWER SUPPLY AND GROUND CIRCUIT

Diagnosis Procedure

INFOID:000000009174368

Regarding Wiring Diagram information, refer to [SN-13. "Wiring Diagram"](#).

1. CHECK FUSE

Check that the following fuse is not blown.

Terminal No.	Signal name	Fuse No.
12	IGN power supply	29 (5A)

Is the fuse blown?

- YES >> Replace the blown fuse after repairing the affected circuit.
NO >> GO TO 2.

2. CHECK POWER SUPPLY CIRCUIT

1. Turn ignition switch OFF.
2. Disconnect sonar control unit connector M70.
3. Check voltage between sonar control unit connector M70 and ground.

Sonar control unit		Ground	Condition	Voltage (Approx.)
Connector	Terminal			
M70	12	—	Ignition switch: ON	Battery voltage

Is the inspection result normal?

- YES >> GO TO 3.
NO >> Repair or replace harness or connectors.

3. CHECK GROUND CIRCUIT

1. Turn ignition switch OFF.
2. Check continuity between sonar control unit connector M70 and ground.

Sonar control unit		Ground	Continuity
Connector	Terminal		
M70	15	—	Yes

Is the inspection result normal?

- YES >> Inspection End.
NO >> Repair or replace harness or connectors.

SONAR SYSTEM

< SYMPTOM DIAGNOSIS >

SYMPTOM DIAGNOSIS

SONAR SYSTEM

Symptom Table

INFOID:000000009174369

Symptom	Possible cause	Reference page
Malfunction is detected in only 1 sensor of display (Always displayed in red).	<ul style="list-style-type: none">• Sonar sensor circuit• Sonar sensor	<ul style="list-style-type: none">• SN-26, "Diagnosis Procedure" (rear LH inner)• SN-27, "Diagnosis Procedure" (rear RH inner)• SN-25, "Diagnosis Procedure" (rear LH outer)• SN-28, "Diagnosis Procedure" (rear RH outer)• SN-35, "Removal and Installation"
Malfunction is detected in all 4 sensors of display (Always displayed in red).	<ul style="list-style-type: none">• Sonar control unit power supply and ground circuits• CAN communication circuits	<ul style="list-style-type: none">• SN-32, "Diagnosis Procedure"• LAN-20, "Trouble Diagnosis Flow Chart"

A
B
C
D
E
F
G
H
I
J
K
L
M
N
O
P

SN

SONAR CONTROL UNIT

< REMOVAL AND INSTALLATION >

REMOVAL AND INSTALLATION

SONAR CONTROL UNIT

Removal and Installation

INFOID:000000009726776

CAUTION:

Before replacing the Sonar Control Unit, perform “READ CONFIGURATION” to save or print current vehicle specification. Refer to [SN-20, "ADDITIONAL SERVICE WHEN REPLACING SONAR CONTROL UNIT : Description"](#).

REMOVAL

1. Remove the instrument lower panel LH. Refer to [IP-25, "Removal and Installation"](#).
2. Disconnect the harness connector from the sonar control unit.
3. Remove screw (A) and the sonar control unit (1).

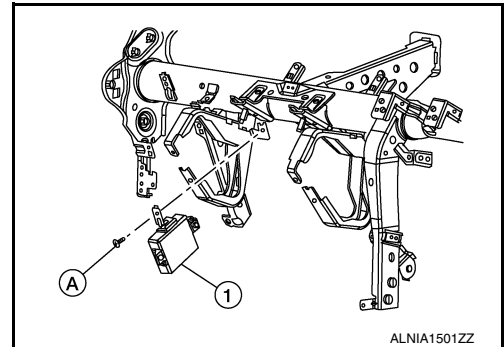

INSTALLATION

Installation is in the reverse order of removal.

CAUTION:

- Be sure to perform “WRITE CONFIGURATION” when replacing Sonar Control Unit. Refer to [SN-21, "CONFIGURATION \(SONAR CONTROL UNIT\) : Work Procedure"](#).

SONAR SENSOR

< REMOVAL AND INSTALLATION >

SONAR SENSOR

Removal and Installation

INFOID:000000009726777

REMOVAL

1. Remove the rear bumper fascia (1). Refer to [EXT-20. "Removal and Installation"](#).
2. Disconnect the harness connector from the rear sonar sensor.
3. Release pawls and remove the rear sonar sensor (3) from the rear sonar sensor finisher (2).

○: Pawl

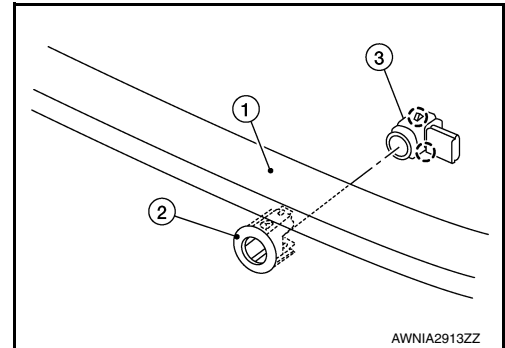

4. Release pawls and remove the rear sonar sensor finisher (1) from the rear bumper fascia (2).

○: Pawl

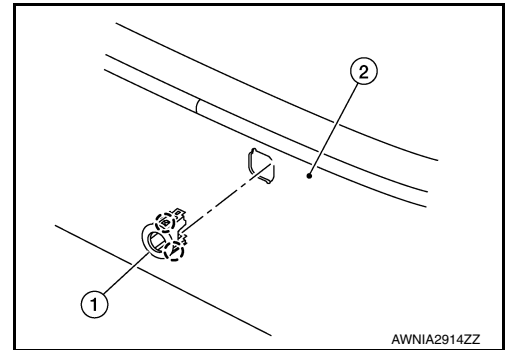

INSTALLATION

Installation is in the reverse order of removal.

A
B
C
D
E
F
G
H
I
J
K
L
M
SN
O
P

BUZZER

< REMOVAL AND INSTALLATION >

BUZZER

Removal and Installation

INFOID:000000009726778

REMOVAL

1. Remove the luggage side lower finisher (RH). Refer to [INT-31. "LUGGAGE SIDE LOWER FINISHER : Removal and Installation"](#).
2. Disconnect the harness connector (B) from the sonar buzzer (1).
3. Remove screws (A) and the sonar buzzer (1).

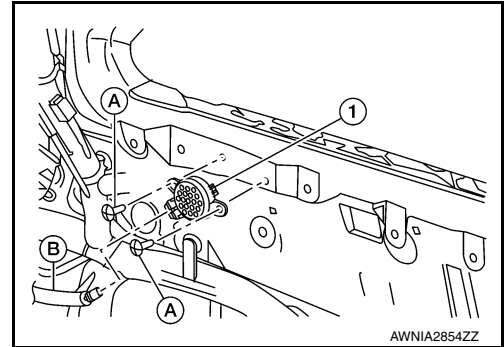

INSTALLATION

Installation is in the reverse order of removal.