

A
EM
C
D
E
F
G
H
I
J
K
L
M
N
O
P

SECTION **EM**

ENGINE MECHANICAL

CONTENTS

| | |
|--|---|
| <p>PRECAUTION 3</p> <p>PRECAUTIONS 3</p> <p style="padding-left: 20px;">Precaution for Supplemental Restraint System (SRS) "AIR BAG" and "SEAT BELT PRE-TENSIONER"3</p> <p style="padding-left: 20px;">Precaution for Procedure without Cowl Top Cover.....3</p> <p style="padding-left: 20px;">Precaution for Drain Coolant and Engine Oil3</p> <p style="padding-left: 20px;">Precaution for Disconnecting Fuel Piping3</p> <p style="padding-left: 20px;">Precaution for Removal and Disassembly3</p> <p style="padding-left: 20px;">Precaution for Inspection, Repair and Replacement4</p> <p style="padding-left: 20px;">Precaution for Assembly and Installation4</p> <p style="padding-left: 20px;">Parts Requiring Angular Tightening4</p> <p style="padding-left: 20px;">Precaution for Liquid Gasket4</p> <p>PREPARATION 6</p> <p>PREPARATION 6</p> <p style="padding-left: 20px;">Special Service Tool6</p> <p style="padding-left: 20px;">Commercial Service Tool7</p> <p>SYSTEM DESCRIPTION10</p> <p>NOISE, VIBRATION, AND HARSHNESS (NVH) TROUBLESHOOTING10</p> <p style="padding-left: 20px;">NVH Troubleshooting - Engine Noise10</p> <p style="padding-left: 20px;">Use the Chart Below to Help You Find the Cause of the Symptom 11</p> <p>PERIODIC MAINTENANCE12</p> <p>DRIVE BELT12</p> <p style="padding-left: 20px;">Exploded View 12</p> <p style="padding-left: 20px;">Checking Drive Belt 12</p> <p style="padding-left: 20px;">Tension Adjustment 12</p> <p style="padding-left: 20px;">Removal and Installation 12</p> <p style="padding-left: 20px;">Removal and Installation of Drive Belt Auto-tensioner 14</p> <p>AIR CLEANER FILTER15</p> <p style="padding-left: 20px;">Exploded View 15</p> | <p style="padding-left: 20px;">Removal and Installation15</p> <p>SPARK PLUG16</p> <p style="padding-left: 20px;">Exploded View 16</p> <p style="padding-left: 20px;">Removal and Installation 16</p> <p>CAMSHAFT VALVE CLEARANCE 18</p> <p style="padding-left: 20px;">Valve Clearance18</p> <p>COMPRESSION PRESSURE22</p> <p style="padding-left: 20px;">On-Vehicle Service22</p> <p>REMOVAL AND INSTALLATION23</p> <p>ENGINE ROOM COVER23</p> <p style="padding-left: 20px;">Exploded View23</p> <p style="padding-left: 20px;">Removal and Installation23</p> <p>AIR CLEANER AND AIR DUCT24</p> <p style="padding-left: 20px;">Exploded View24</p> <p style="padding-left: 20px;">Removal and Installation24</p> <p>INTAKE MANIFOLD COLLECTOR26</p> <p style="padding-left: 20px;">Exploded View26</p> <p style="padding-left: 20px;">Removal and Installation26</p> <p>INTAKE MANIFOLD29</p> <p style="padding-left: 20px;">Exploded View29</p> <p style="padding-left: 20px;">Removal and Installation29</p> <p>EXHAUST MANIFOLD AND THREE WAY CATALYST31</p> <p style="padding-left: 20px;">Exploded View31</p> <p style="padding-left: 20px;">Removal and Installation (bank 2)31</p> <p style="padding-left: 20px;">Removal and Installation (bank 1)33</p> <p>OIL PAN AND OIL STRAINER36</p> <p style="padding-left: 20px;">Exploded View36</p> <p style="padding-left: 20px;">Removal and Installation (Lower Oil Pan)36</p> <p style="padding-left: 20px;">Removal and Installation (Upper Oil Pan)37</p> <p>IGNITION COIL42</p> <p style="padding-left: 20px;">Exploded View42</p> |
|--|---|

| | | | |
|--|-----------|--|------------|
| Removal and Installation (LH) | 42 | Inspection After Disassembly | 95 |
| Removal and Installation (RH) | 42 | ENGINE MOUNT | 100 |
| ROCKER COVER | 43 | ENGINE MOUNT (FRONT) | 100 |
| Exploded View | 43 | ENGINE MOUNT (FRONT) : Removal and Instal- | |
| Removal and Installation (LH) | 43 | lation | 100 |
| Removal and Installation (RH) | 44 | UNIT REMOVAL AND INSTALLATION ... | 103 |
| FUEL INJECTOR AND FUEL TUBE | 47 | ENGINE ASSEMBLY | 103 |
| Exploded View | 47 | 2WD | 103 |
| Removal and Installation | 47 | 2WD : Exploded View | 103 |
| Inspection | 51 | 2WD : Removal and Installation | 103 |
| VALVE TIMING CONTROL | 52 | 4WD | 107 |
| Exploded View | 52 | 4WD : Exploded View | 107 |
| Valve Timing Control Cover (bank 1) | 53 | 4WD : Removal and Installation | 108 |
| Valve Timing Control Cover (bank 2) | 54 | UNIT DISASSEMBLY AND ASSEMBLY .. | 112 |
| FRONT TIMING CHAIN CASE | 55 | CYLINDER BLOCK | 112 |
| Exploded View | 55 | Exploded View | 112 |
| Removal and Installation | 55 | Disassembly and Assembly | 113 |
| TIMING CHAIN | 63 | Inspection | 122 |
| Exploded View | 63 | Dowel Pin Alignment | 132 |
| Removal and Installation | 63 | SERVICE DATA AND SPECIFICATIONS | |
| REAR TIMING CHAIN CASE | 71 | (SDS) | 134 |
| Exploded View | 71 | SERVICE DATA AND SPECIFICATIONS | |
| Removal and Installation | 71 | (SDS) | 134 |
| CAMSHAFT | 76 | General Specification | 134 |
| Exploded View | 76 | Drive Belt | 134 |
| Removal and Installation | 76 | Spark Plug | 135 |
| Inspection After Removal | 81 | Intake Manifold | 135 |
| Inspection after Installation | 84 | Exhaust Manifold | 135 |
| OIL SEAL | 86 | Camshaft | 135 |
| Removal and Installation of Valve Oil Seal | 86 | Cylinder Head | 137 |
| Removal and Installation of Front Oil Seal | 86 | Cylinder Block | 141 |
| Removal and Installation of Rear Oil Seal | 88 | Main Bearing | 144 |
| CYLINDER HEAD | 90 | Connecting Rod Bearing | 145 |
| Exploded View | 90 | Drive Plate | 146 |
| Removal and Installation | 90 | | |
| Disassembly and Assembly | 93 | | |

PRECAUTIONS

< PRECAUTION >

PRECAUTION

PRECAUTIONS

Precaution for Supplemental Restraint System (SRS) "AIR BAG" and "SEAT BELT PRE-TENSIONER"

INFOID:000000011148346

The Supplemental Restraint System such as "AIR BAG" and "SEAT BELT PRE-TENSIONER", used along with a front seat belt, helps to reduce the risk or severity of injury to the driver and front passenger for certain types of collision. Information necessary to service the system safely is included in the SR and SB section of this Service Manual.

WARNING:

- To avoid rendering the SRS inoperative, which could increase the risk of personal injury or death in the event of a collision which would result in air bag inflation, all maintenance must be performed by an authorized NISSAN/INFINITI dealer.
- Improper maintenance, including incorrect removal and installation of the SRS, can lead to personal injury caused by unintentional activation of the system. For removal of Spiral Cable and Air Bag Module, see the SR section.
- Do not use electrical test equipment on any circuit related to the SRS unless instructed to in this Service Manual. SRS wiring harnesses can be identified by yellow and/or orange harnesses or harness connectors.

PRECAUTIONS WHEN USING POWER TOOLS (AIR OR ELECTRIC) AND HAMMERS

WARNING:

- When working near the Airbag Diagnosis Sensor Unit or other Airbag System sensors with the Ignition ON or engine running, DO NOT use air or electric power tools or strike near the sensor(s) with a hammer. Heavy vibration could activate the sensor(s) and deploy the air bag(s), possibly causing serious injury.
- When using air or electric power tools or hammers, always switch the Ignition OFF, disconnect the battery and wait at least three minutes before performing any service.

Precaution for Procedure without Cowl Top Cover

INFOID:000000011148347

When performing the procedure after removing cowl top cover, cover the lower end of windshield with urethane, etc to prevent damage to windshield.

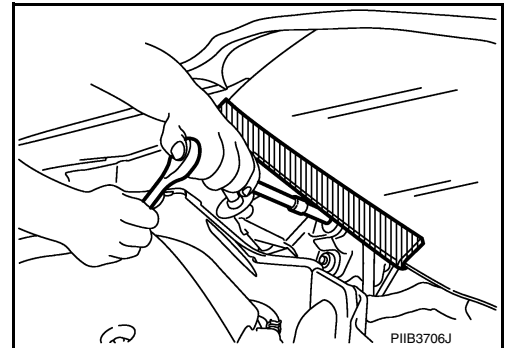

Precaution for Drain Coolant and Engine Oil

INFOID:000000011148348

- Drain engine coolant and engine oil after the engine has cooled completely.

Precaution for Disconnecting Fuel Piping

INFOID:000000011148349

- Before starting work, make sure no fire or spark producing items are in the work area.
- Release fuel pressure before disassembly.
- After disconnecting pipes, plug openings to stop fuel leakage.

Precaution for Removal and Disassembly

INFOID:000000011148350

- When instructed to use special service tools, use the specified tools. Always be careful to work safely, avoid forceful or uninstructed operations.
- Exercise maximum care to avoid damage to mating or sliding surfaces.
- Cover openings of engine system with tape or the equivalent, if necessary, to seal out foreign materials.

A

EM

C

D

E

F

G

H

I

J

K

L

M

N

O

P

PRECAUTIONS

< PRECAUTION >

- Mark and arrange disassembly parts in an organized way for easy troubleshooting and assembly.
- When loosening nuts and bolts, as a basic rule, start with the one furthest outside, then the one diagonally opposite, and so on. If the order of loosening is specified, do exactly as specified. Power tools may be used where noted in the step.

Precaution for Inspection, Repair and Replacement

INFOID:000000011148351

- Thoroughly inspect parts before repairing or replacing them, even if they are new. Replace as necessary.

Precaution for Assembly and Installation

INFOID:000000011148352

- Use torque wrench to tighten bolts or nuts to specification.
- When tightening nuts and bolts, as a basic rule, equally tighten in several different steps starting with the ones in center, then ones on inside and outside diagonally in this order. If the order of tightening is specified, do exactly as specified.
- Replace with new gasket, packing, oil seal or O-ring.
- Dowel pins are used in several critical parts for correct alignment. When replacing and reassembling parts with dowel pins, check that dowel pins are installed in their original positions.
- Thoroughly wash, clean, and air-blow each part. Carefully check oil or coolant passages for any restriction and blockage.
- Avoid damaging sliding or mating surfaces. Completely remove foreign materials such as cloth lint or dust. Before assembly, oil sliding surfaces well.
- Release air within route when refilling after draining coolant.
- Before starting engine, apply fuel pressure to fuel lines with turning ignition switch ON (with engine stopped). Then make sure that there are no leaks at fuel line connections.
- After repairing, start engine and increase engine speed to check coolant, fuel, oil, and exhaust systems for leaks.

Parts Requiring Angular Tightening

INFOID:000000011148353

- Use an angle wrench for the final tightening of the following engine parts:
 - Cylinder head bolts
 - Main bearing cap bolts
 - Connecting rod cap nuts
 - Crankshaft pulley bolt (No angle wrench is required as the bolt flange is provided with notches for angular tightening)
- Do not use a torque value for final tightening.
- The torque value for these parts are for a preliminary step.
- Ensure thread and seat surfaces are clean and coated with engine oil.

Precaution for Liquid Gasket

INFOID:000000011148354

REMOVAL OF LIQUID GASKET

- After removing the bolts and nuts, separate the mating surface and remove the old liquid gasket using Tool.

Tool number : KV1011100 (J-37228)

CAUTION:

Do not damage the mating surfaces.

- In areas where the Tool is difficult to use, use a plastic hammer to lightly tap (1) the Tool where the liquid gasket is applied. Use a plastic hammer to slide (2) the Tool by tapping on the side.

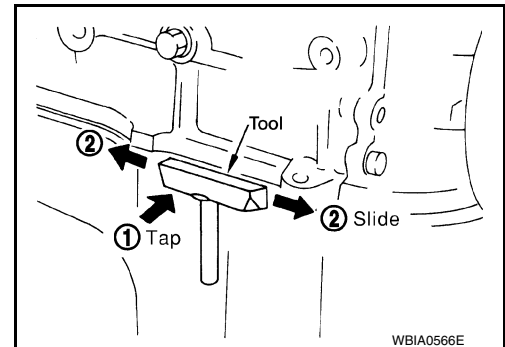

WBIA0566E

LIQUID GASKET APPLICATION PROCEDURE

PRECAUTIONS

< PRECAUTION >

1. Using suitable tool (A), remove old liquid gasket adhering to the liquid gasket application surface and the mating surface.
 - Remove liquid gasket completely from the groove of the liquid gasket application surface, mounting bolts, and bolt holes.
2. Wipe the liquid gasket application surface and the mating surface with white gasoline (lighting and heating use) to remove adhering moisture, grease and foreign materials.

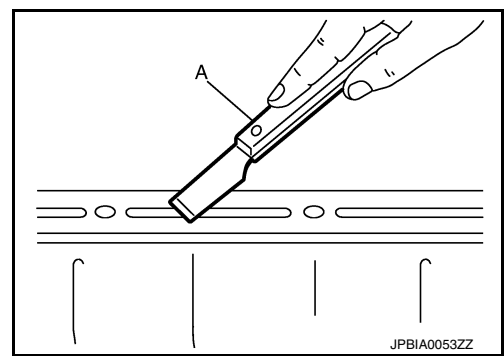

3. Attach the liquid gasket tube to the suitable tool.
Use Genuine RTV Silicone Sealant or equivalent. Refer to [GI-22, "Recommended Chemical Products and Sealants"](#).
4. Apply the liquid gasket without gaps to the specified location with the specified dimensions.

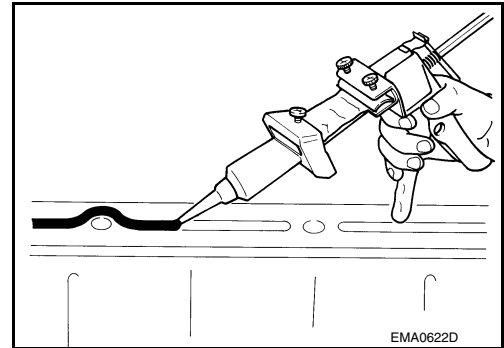

- If there is a groove for the liquid gasket application, apply the liquid gasket to the groove.
- Normally apply the liquid gasket on the inside edge of the bolt holes. Also apply to the outside edge of the bolt holes when specified in the procedure.
- Within five minutes of liquid gasket application, install the mating component.
- If the liquid gasket protrudes, wipe it off immediately.
- Do not retighten mounting bolts after the installation.
- Wait 30 minutes or more after installation before refilling the engine with engine oil or engine coolant.

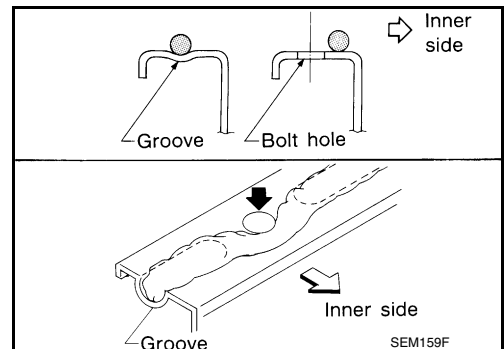

CAUTION:

If there are more specific instructions in the procedures contained in this manual concerning liquid gasket application, observe them.

PREPARATION

< PREPARATION >

PREPARATION

PREPARATION

Special Service Tool

INFOID:000000011148355

The actual shape of the tools may differ from those illustrated here.

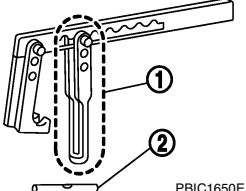
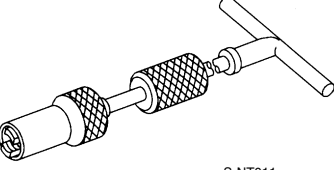
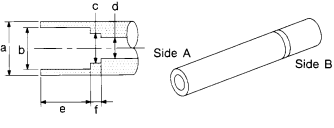
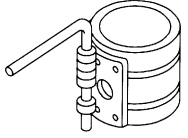
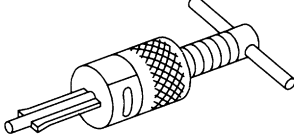
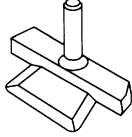
| Tool number (TechMate No.) Tool name | Description |
|--|--|
| KV10116200 (J-26336-A) Valve spring compressor 1. KV10115900 (J-26336-20) Attachment 2. KV10109220 (—) Adapter |  Disassembling valve mechanism Part (1) is a component of KV10116200 (J-26336-A), but part (2) is not. |
| KV10107902 (J-38959) Valve oil seal puller |  Removing valve oil seal |
| KV10115600 (J-38958) Valve oil seal drift |  Installing valve oil seal Use side A. a: 20 (0.79) dia. d: 8 (0.31) dia. b: 13 (0.51) dia. e: 10.7 (0.421) dia. c: 10.3 (0.406) dia. f: 5 (0.20) dia. Unit: mm (in) |
| EM03470000 (J-8037) Piston ring compressor |  Installing piston assembly into cylinder bore |
| ST16610001 (J-23907) Pilot bushing puller |  Removing crankshaft pilot bushing |
| KV10111100 (J-37228) Seal cutter |  Removing steel oil pan and rear timing chain case |

PREPARATION

< PREPARATION >

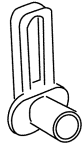
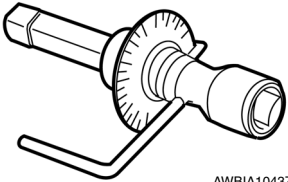
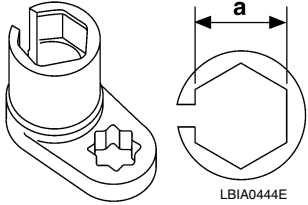
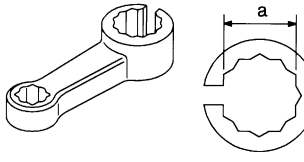
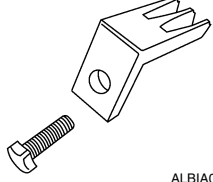
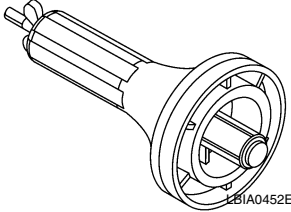
| Tool number (TechMate No.) Tool name | Description |
|--|--|
| 16441 6N210 (J-45488) Quick connector release  PBIC0198E | Removing fuel tube quick connectors in engine room (Available in SEC. 164 of PARTS CATALOG: Part No. 16441 6N210) |
| KV10112100 (BT-8653-A) Angle wrench  AWBIA1043ZZ | Tightening bolts for cylinder head, main bearing cap and connecting rod cap |
| KV991J0050 (J-44626) Air fuel sensor Socket  LBIA0444E | Loosening or tightening air fuel ratio A/F sensor a: 22 mm (0.87 in) |
| KV10114400 (J-38365) Heated oxygen sensor wrench  NT636 | Loosening or tightening rear heated oxygen sensor a: 22 mm (0.87 in) |
| — (J-50288) Ring gear stopper  ALBIA0675ZZ | Removing and installing crankshaft pulley |
| — (J-47128) Seal installer  LBIA0452E | Installing rear main seal |





A
EM
C
D
E
F
G
H
I
J
K
L
M
N
O
P

Commercial Service Tool

INFOID:000000011148356

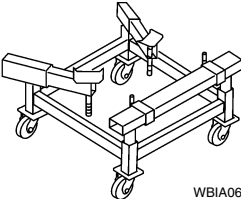
PREPARATION

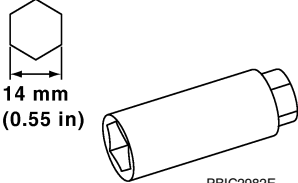
< PREPARATION >

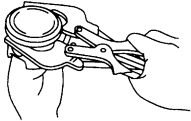
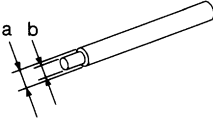
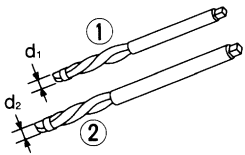
| (TechMate No.) Tool name | Description |
|--|---|
| (J-47242) Engine support table  <small>WBIA0658E</small> | Removing engine and transaxle assembly |
| (—) Power tool  <small>PIIB1407E</small> | Loosening nuts, screws and bolts |
| (—) Spark plug wrench  <small>PBIC2982E</small> | Removing and installing spark plug |
| (—) Valve seat cutter set  <small>NT048</small> | Finishing valve seat dimensions |
| (—) Piston ring expander  <small>NT030</small> | Removing and installing piston ring |
| (—) Valve guide drift  <small>NT015</small> | Removing and installing valve guide Intake & Exhaust: a: 9.5 mm (0.374 in) dia. b: 5.5 mm (0.217 in) dia. |
| (—) Valve guide reamer  <small>NT016</small> | Reaming valve guide (1) or hole for oversize valve guide (2) Intake & Exhaust: d1: 6.0 mm (0.236 in) dia. d2: 10.2 mm (0.402 in) dia. |

PREPARATION

< PREPARATION >

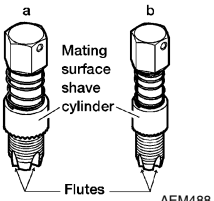
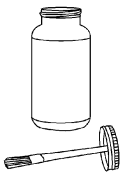
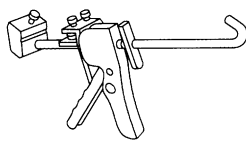
| (TechMate No.) Tool name | Description |
|--|--|
| (J-43897-18) (J-43897-12) Oxygen sensor thread cleaner |  <p>Reconditioning the exhaust system threads before installing a new oxygen sensor (Use with anti-seize lubricant shown below.) a: J-43897-18 (18 mm dia.) for zirconia oxygen sensor b: J-43897-12 (12 mm dia.) for titania oxygen sensor</p> |
| (—) Anti-seize lubricant (Permatex 133AR or equivalent meeting MIL specification MIL-A-907) | <p>Lubricating oxygen sensor thread cleaning tool when reconditioning exhaust system threads</p>  |
| (—) Tube presser | <p>Pressing the tube of liquid gasket</p>  |

A

EM

C

D

E

F

G

H

I

J

K

L

M

N

O

P

NOISE, VIBRATION, AND HARSHNESS (NVH) TROUBLESHOOTING

< SYSTEM DESCRIPTION >

SYSTEM DESCRIPTION

NOISE, VIBRATION, AND HARSHNESS (NVH) TROUBLESHOOTING

NVH Troubleshooting - Engine Noise

INFOID:000000011148357

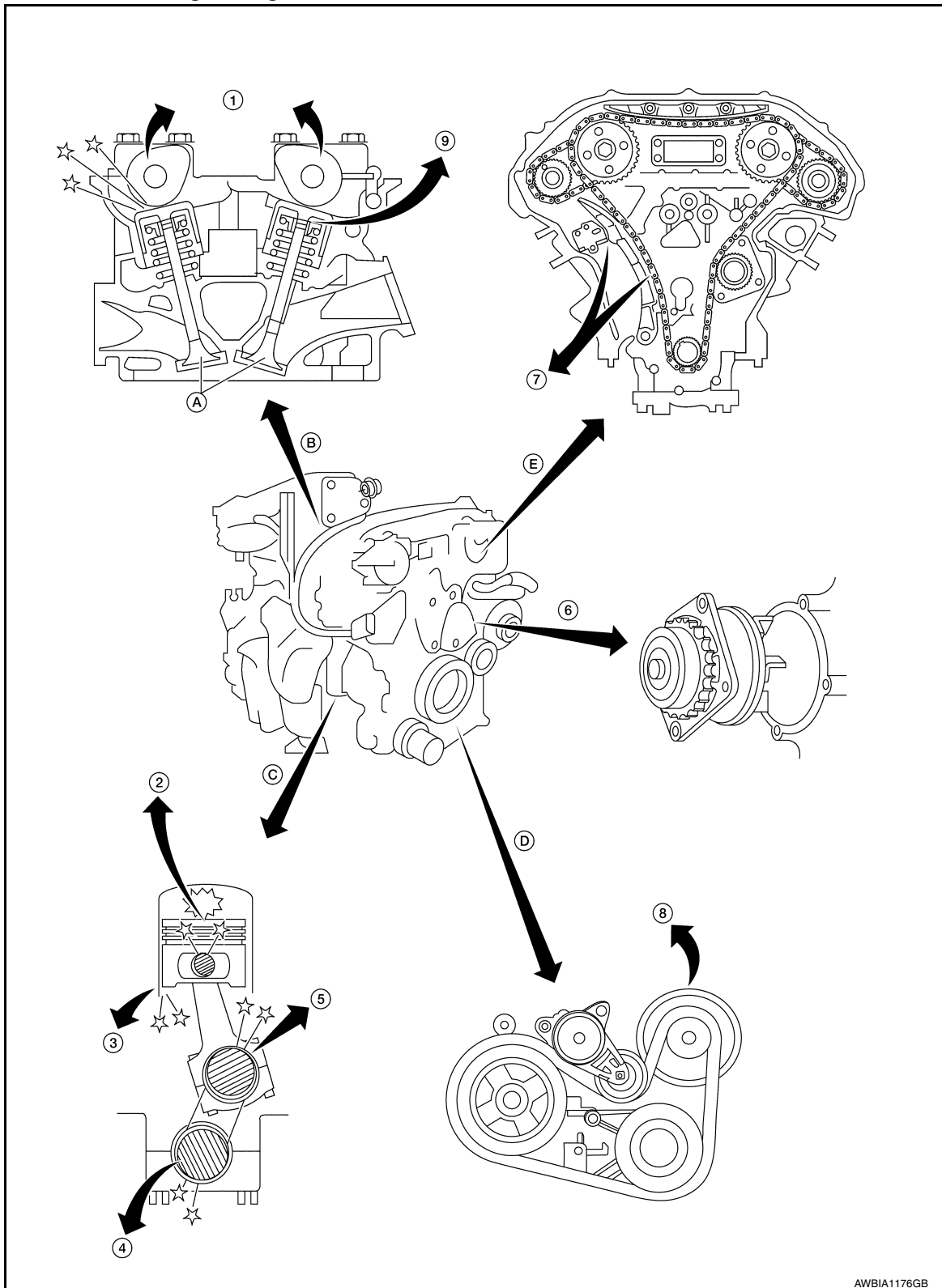

AWBIA1176GB

- | | | |
|---------------------------|---------------------------------|----------------------|
| 1. Camshaft bearing noise | 2. Piston pin noise | 3. Piston slap noise |
| 4. Main bearing noise | 5. Connecting rod bearing noise | 6. Water pump noise |

NOISE, VIBRATION, AND HARSHNESS (NVH) TROUBLESHOOTING

< SYSTEM DESCRIPTION >

- | | | |
|---|---|-----------------------|
| 7. Timing chain and chain tensioner noise | 8. Drive belt noise (Sticking/Slipping) | 9. Tappet noise |
| A. Valve | B. Valve mechanism | C. Rotation mechanism |
| D. Drive belt | E. Timing chain | |

A

EM

Use the Chart Below to Help You Find the Cause of the Symptom

INFOID:000000011148358

1. Locate the area where noise occurs.
2. Confirm the type of noise.
3. Specify the operating condition of engine.
4. Check specified noise source. Repair or replace the identified part as necessary.

C

D

| Location of noise | Type of noise | Operating condition of engine | | | | | | Source of noise | Check item | Reference page |
|---|----------------------|-------------------------------|---------------|---------------|-------------|-------------|---------------|--|--|------------------------|
| | | Before warm-up | After warm-up | When starting | When idling | When racing | While driving | | | |
| Top of engine Rocker cover Cylinder head | Ticking or clicking | C | A | — | A | B | — | Tappet noise | Valve clearance | EM-18 |
| | Rattle | C | A | — | A | B | C | Camshaft bearing noise | Camshaft journal clearance Camshaft runout | EM-76 |
| Crankshaft pulley Cylinder block (Side of engine) Oil pan | Slap or knock | — | A | — | B | B | — | Piston pin noise | Piston and piston pin clearance Connecting rod bushing clearance | EM-22 |
| | Slap or rap | A | — | — | B | B | A | Piston slap noise | Piston-to-bore clearance Piston ring side clearance Piston ring end gap Connecting rod bend and torsion | EM-113 |
| | Knock | A | B | C | B | B | B | Connecting rod bearing noise | Connecting rod bushing clearance (Small end) Connecting rod bearing clearance (Big end) | EM-113 |
| | Knock | A | B | — | A | B | C | Main bearing noise | Main bearing oil clearance Crankshaft runout | EM-113 |
| Front of engine Timing chain cover | Tapping or ticking | A | A | — | B | B | B | Timing chain and chain tensioner noise | Timing chain cracks and wear Timing chain tensioner operation | EM-63 |
| Front of engine | Squeaking or fizzing | A | B | — | B | — | C | Drive belts (Sticking or slipping) | Drive belts deflection | EM-12 |
| | Creaking | A | B | A | B | A | B | Drive belts (Slipping) | Idler pulley bearing operation | |
| | Squall Creak | A | B | — | B | A | B | Water pump noise | Water pump operation | CO-19 |

E

F

G

H

I

J

K

L

M

N

O

P

A: Closely related B: Related C: Sometimes related —: Not related

DRIVE BELT

< PERIODIC MAINTENANCE >

PERIODIC MAINTENANCE

DRIVE BELT

Exploded View

INFOID:000000011148359

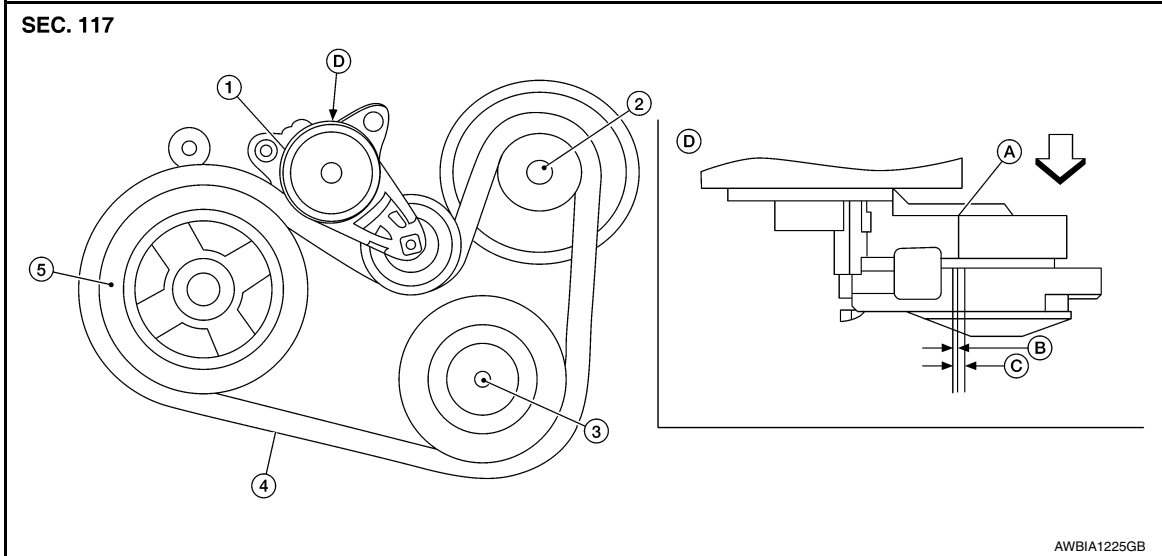

- | | | |
|------------------------------|-----------------------|--|
| 1. Drive belt auto-tensioner | 2. Generator | 3. A/C compressor |
| 4. Drive belt | 5. Crankshaft pulley | A. Drive belt auto-tensioner indicator |
| B. New drive belt range | C. Possible use range | D. View D |
- ↶ Engine front

Checking Drive Belt

INFOID:000000011148360

WARNING:

Inspect and check the drive belt with the engine off.

1. Visually check entire drive belt for wear, damage or cracks.
2. Check that the drive belt auto-tensioner indicator is within the possible use range.

NOTE:

- When new drive belt is installed, the drive belt auto-tensioner indicator should be within the new drive belt range.
 - Check the drive belt auto-tensioner indicator when the engine is cold.
3. If the drive belt auto-tensioner indicator is out of the possible use range or drive belt is damaged, replace drive belt.

Tension Adjustment

INFOID:000000011148361

- Drive belt tension is automatically adjusted by the drive belt auto-tensioner.
- Drive belt tension is not manually adjustable.

Removal and Installation

INFOID:000000011148362

REMOVAL

1. Remove the front wheel and tire (RH) using a power tool. Refer to [WT-58, "Adjustment"](#).
2. Remove the fender protector side cover (RH). Refer to [EXT-28, "FENDER PROTECTOR : Exploded View"](#).

DRIVE BELT

< PERIODIC MAINTENANCE >

3. While securely holding the hexagonal part in pulley center of drive belt auto-tensioner, move in the direction of arrow (loosening direction of drive belt auto-tensioner) using suitable tool.

WARNING:

- Avoid placing hand in a location where pinching may occur if the holding tool accidentally comes off.

CAUTION:

- Do not loosen the drive belt auto-tensioner pulley bolt. (Do not turn it counterclockwise. If turned counterclockwise, the complete drive belt auto-tensioner must be replaced as a unit, including pulley.)

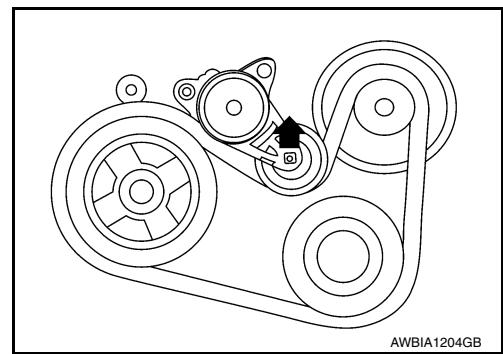

4. Insert a rod approximately 6 mm (0.24 in) in diameter through the rear of drive belt auto-tensioner into retaining boss to lock drive belt auto-tensioner pulley.

NOTE:

Leave drive belt auto-tensioner pulley arm locked until drive belt is installed.

5. Remove drive belt from crankshaft pulley and then remove it from the other pulleys.

INSTALLATION

1. Install the drive belt onto all of the pulleys.

CAUTION:

Confirm belt is completely set on the pulleys.

2. Release drive belt auto-tensioner, and apply tension to drive belt.

WARNING:

- Avoid placing hand in a location where pinching may occur if the holding tool accidentally comes off.

CAUTION:

- Do not loosen the drive belt auto-tensioner pulley bolt. (Don't turn it counterclockwise. If turned counterclockwise, the complete drive belt auto-tensioner must be replaced as a unit, including pulley.)

3. Turn crankshaft pulley clockwise several times to equalize tension between each pulley.
4. Confirm drive belt auto-tensioner indicator is within the possible use range. Refer to [EM-12, "Checking Drive Belt"](#).
5. Install the fender protector side cover (RH). Refer to [EXT-28, "FENDER PROTECTOR : Exploded View"](#).
6. Install the front wheel and tire (RH) using a power tool. Refer to [WT-58, "Adjustment"](#).

DRIVE BELT

< PERIODIC MAINTENANCE >

Removal and Installation of Drive Belt Auto-tensioner

INFOID:000000011148363

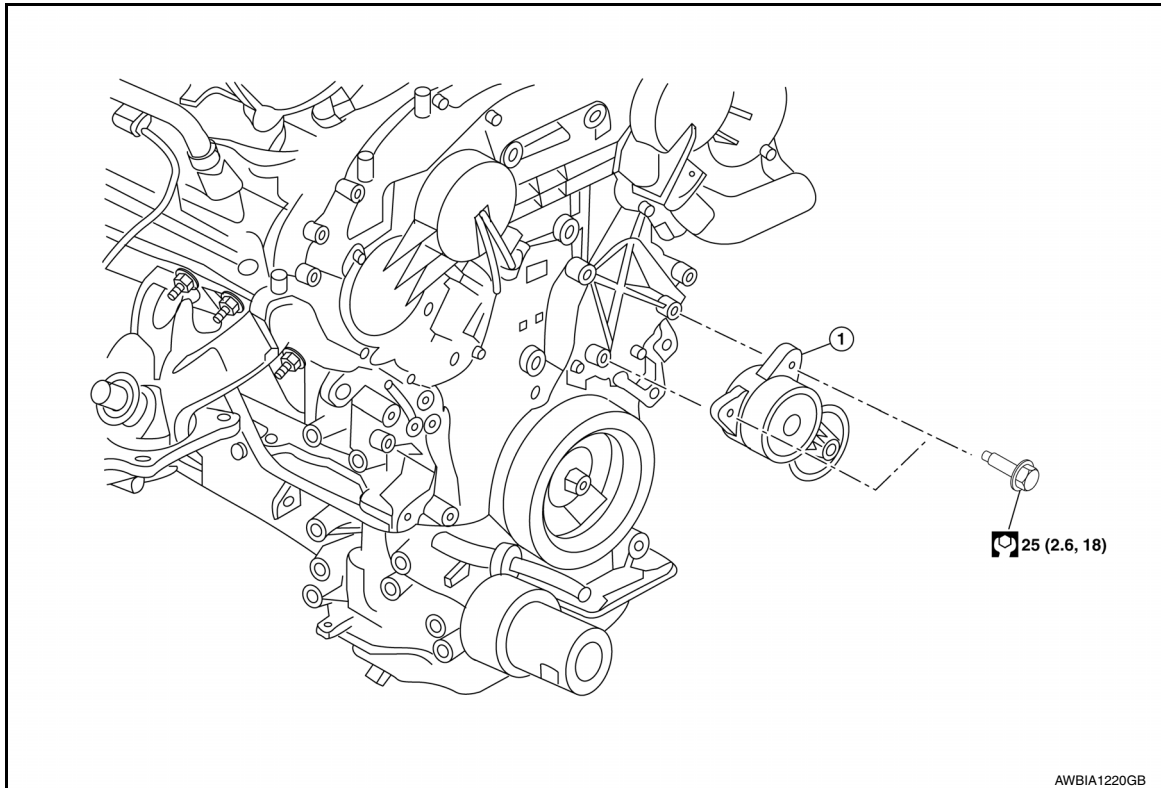

1. Drive belt auto-tensioner

REMOVAL

CAUTION:

The complete drive belt auto-tensioner must be replaced as a unit, including the pulley.

1. Remove the drive belt. Refer to [EM-12, "Removal and Installation"](#).
2. Remove the drive belt auto-tensioner.

CAUTION:

Do not loosen the drive belt auto-tensioner pulley bolt. (Do not turn it counterclockwise. If turned counterclockwise, the complete drive belt auto-tensioner must be replaced as a unit, including pulley).

INSTALLATION

Installation is in the reverse order of removal.

CAUTION:

- If there is damage greater than peeled paint, replace drive belt auto-tensioner.
- Do not swap the pulley between the new and old drive belt auto-tensioner.
- The complete drive belt auto-tensioner must be replaced as a unit, including the pulley.

AIR CLEANER FILTER

< PERIODIC MAINTENANCE >

AIR CLEANER FILTER

Exploded View

INFOID:000000011148364

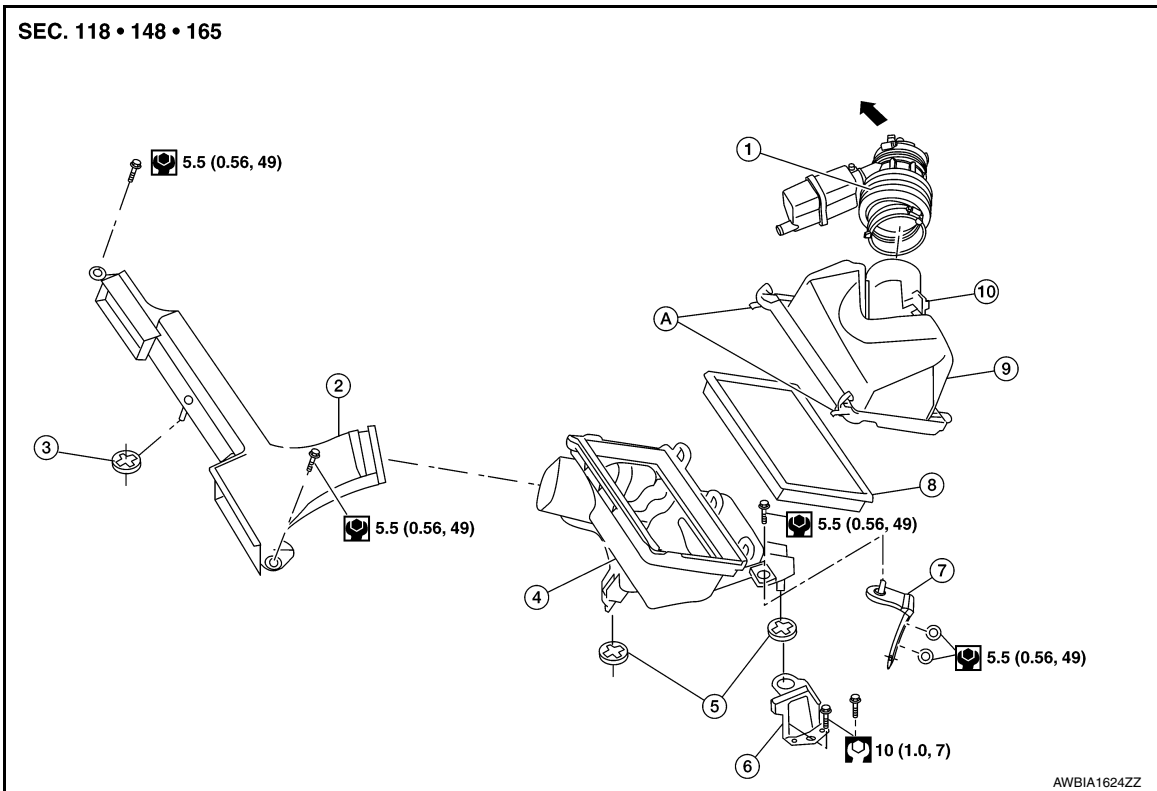

- | | | |
|---|--------------------------------|---|
| 1. Air duct hose and resonator assembly | 2. Front air duct | 3. Grommet |
| 4. Air cleaner case (lower) | 5. Grommets | 6. Air cleaner case mounting bracket |
| 7. Bracket | 8. Air cleaner filter | 9. Air cleaner case (upper) |
| 10. Mass air flow sensor | A. Air cleaner case side clips | ← To electric throttle control actuator clips |

Removal and Installation

INFOID:000000011148365

REMOVAL

CAUTION:

It is not necessary to remove the front air duct to replace the air cleaner filter.

NOTE:

Replace the air cleaner filter per the periodic maintenance schedule or as necessary. Refer to [MA-9, "FOR USA AND CANADA : Introduction of Periodic Maintenance"](#) (United States and Canada) or [MA-12, "FOR MEXICO : Periodic Maintenance"](#) (Mexico).

1. Unhook air cleaner case side clips and lift air cleaner case (upper).
2. Remove the air cleaner filter.

INSTALLATION

Installation is in the reverse order of removal.

SPARK PLUG

< PERIODIC MAINTENANCE >

SPARK PLUG

Exploded View

INFOID:000000011148366

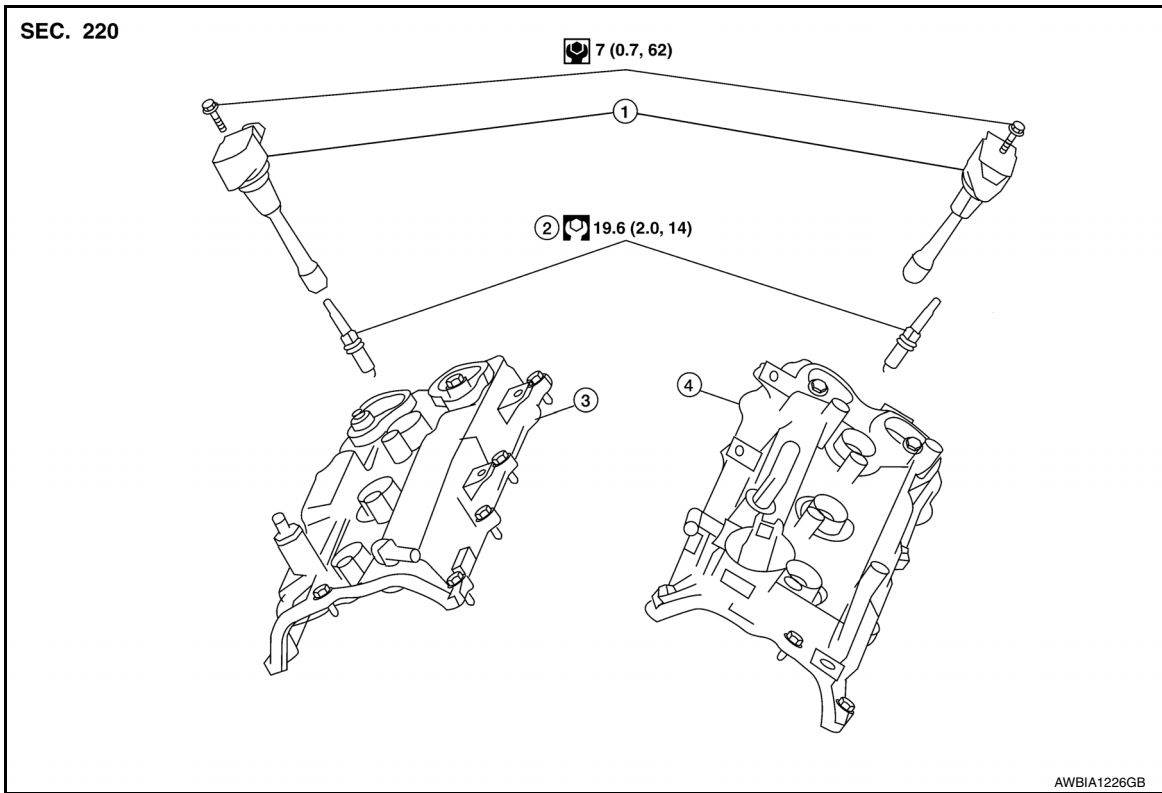

1. Ignition coil

2. Spark plug

3. Rocker cover (RH)

4. Rocker cover (LH)

Removal and Installation

INFOID:000000011148367

REMOVAL

1. Remove the ignition coil. Refer to [EM-42. "Removal and Installation \(LH\)"](#) (LH) and [EM-42. "Removal and Installation \(RH\)"](#) (RH).
2. Remove the spark plug using a suitable tool.

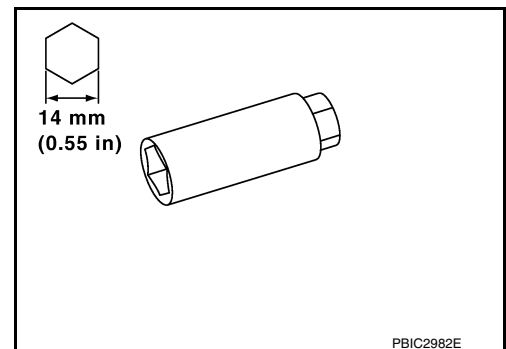

INSPECTION AFTER REMOVAL

SPARK PLUG

< PERIODIC MAINTENANCE >

Use the standard type spark plug for normal condition.

Spark plug : Refer to [EM-135, "Spark Plug"](#).

CAUTION:

- Do not drop or shock spark plug. Discard spark plug if dropped.
- Do not use a wire brush for cleaning.
- If plug is covered with carbon, a spark plug cleaner may be used.

Cleaner air pressure : less than 588 kPa (6 kg/cm², 85 psi)

Cleaning time : less than 20 seconds

- Spark plug gap adjustment is not required between replacement intervals.
- Measure spark plug gap. When it exceeds the limit, replace spark plug even if it is within the specified replacement mileage. Refer to [EM-135, "Spark Plug"](#).

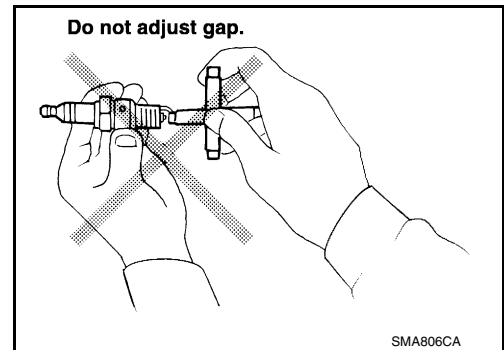
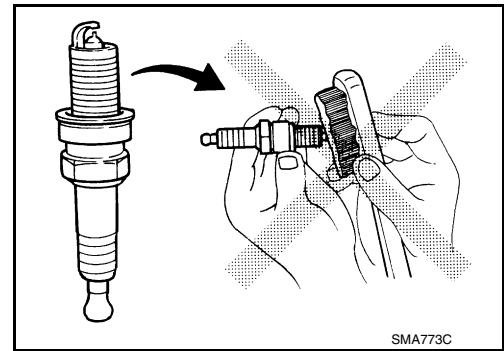

INSTALLATION

Installation is in the reverse order of removal.

| | |
|----------------|-------------------|
| Make | DENSO |
| Standard type* | FXE22HR11 |
| Gap (nominal) | 1.1 mm (0.043 in) |

*: Always check with the Parts Department for the latest parts information.

A
EM
C
D
E
F
G
H
I
J
K
L
M
N
O
P

CAMSHAFT VALVE CLEARANCE

< PERIODIC MAINTENANCE >

CAMSHAFT VALVE CLEARANCE

Valve Clearance

INFOID:000000011148368

CHECKING

CAUTION:

Check valve clearance while engine is cold and not running.

NOTE:

Perform valve clearance inspection after removal, installation or replacement of camshaft or valve parts, or as necessary.

1. Remove the air duct with air cleaner case, collectors, hoses, wires, harnesses, and connectors. Refer to [EM-24. "Removal and Installation"](#).
2. Remove the intake manifold collector. Refer to [EM-26. "Removal and Installation"](#).
3. Remove the ignition coils and spark plugs. Refer to [EM-42. "Exploded View"](#).
4. Remove the rocker covers. Refer to [EM-43. "Exploded View"](#).
5. Set No.1 cylinder at TDC on its compression stroke.

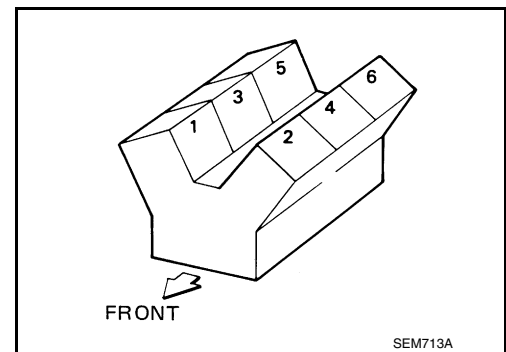

- a. Align pointer (A) with TDC mark (0°) on crankshaft pulley.

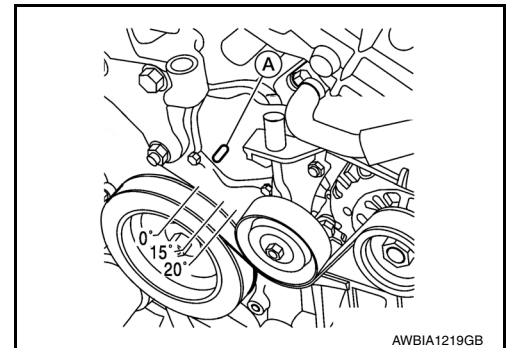

- b. Check that the valve lifters on No.1 cylinder are loose and valve lifters on No.4 are tight. If not, turn the crankshaft one full revolution (360°) and align as shown.

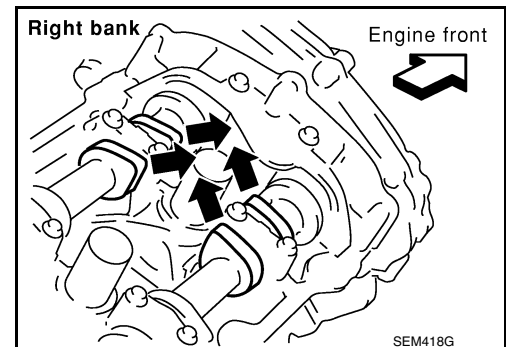

CAMSHAFT VALVE CLEARANCE

< PERIODIC MAINTENANCE >

6. Check only the valves as shown.

| Crank Position | Valve No. 1 | Valve No. 2 | Valve No. 3 | Valve No. 6 |
|----------------|-------------|-------------|-------------|-------------|
| No. 1 TDC | Intake | Exhaust | Exhaust | Intake |

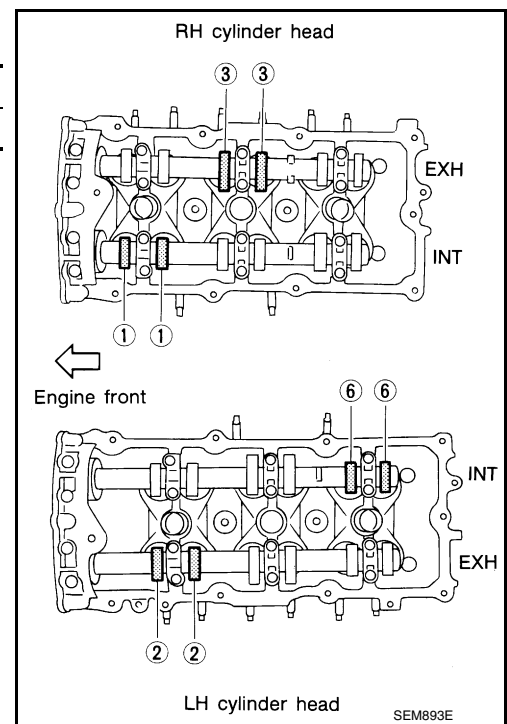

a. Using suitable tool, measure the clearance between the valve lifter and camshaft.

Valve clearance : Refer to [EM-134](#),
"General Specification".

b. Record any valve clearance measurements which are out of specification. They will be used later to determine the required replacement lifter size.

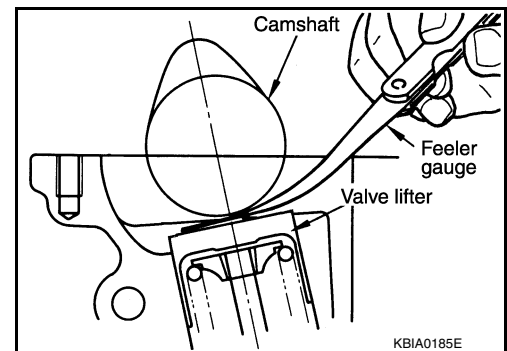
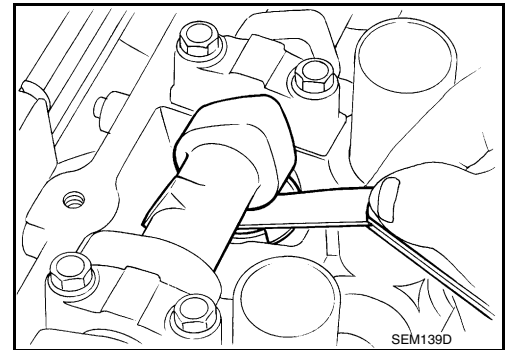

7. Turn crankshaft 240°.

8. Set No.3 cylinder at TDC on its compression stroke.

CAMSHAFT VALVE CLEARANCE

< PERIODIC MAINTENANCE >

9. Check only those valves as shown.

| Crank Position | Valve No. 2 | Valve No. 3 | Valve No. 4 | Valve No. 5 |
|----------------|-------------|-------------|-------------|-------------|
| No. 3 TDC | Intake | Intake | Exhaust | Exhaust |

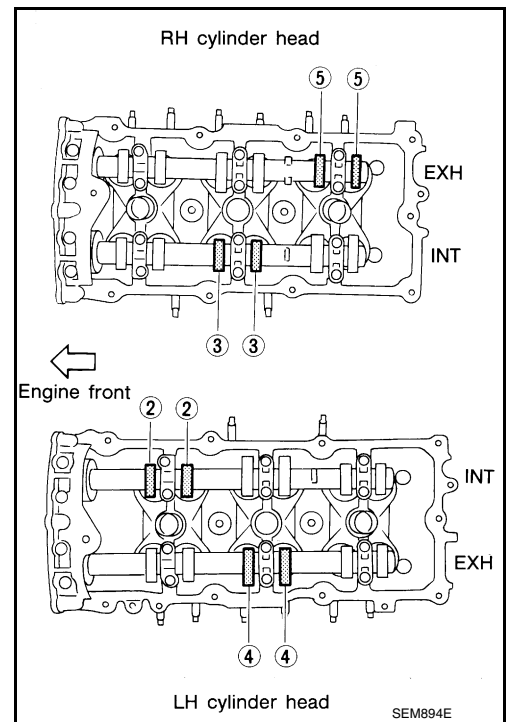

10. Turn the crankshaft 240° and align as above.
11. Set No.5 cylinder at TDC on its compression stroke.
12. Check only those valves as shown.

| Crank Position | Valve No. 1 | Valve No. 4 | Valve No. 5 | Valve No. 6 |
|----------------|-------------|-------------|-------------|-------------|
| No. 5 TDC | Exhaust | Intake | Intake | Exhaust |

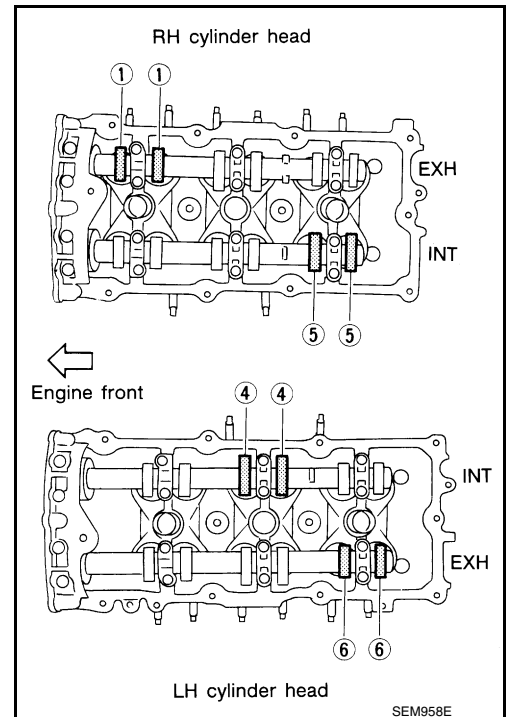

13. Perform adjustment if the measured values are out of the specification range.
14. Installation of components is in the reverse order of removal.

VALVE ADJUSTING

CAUTION:

Adjust valve clearance while engine is cold.

NOTE:

- Perform adjustment by selecting the correct head thickness of the valve lifter (adjusting shims are not used).

CAMSHAFT VALVE CLEARANCE

< PERIODIC MAINTENANCE >

- The specified valve lifter thickness dimension is measured at room temperature.
- Use specifications for hot engine for hot engine condition to confirm valve clearances.

1. Remove the camshaft.
2. Remove the valve lifter that was measured as being outside the standard specifications.
3. Measure the center thickness of the removed valve lifter using suitable tool as shown.

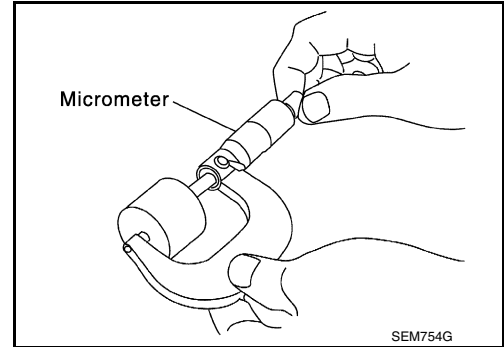

4. Use the equation below to calculate the replacement valve lifter thickness.

Valve lifter thickness calculation: $(C_1 - C_2) + t_1 = t$

C₁ = measured valve clearance

C₂ = standard valve clearance

t₁ = thickness of the removed valve lifter

t = thickness of the replacement valve lifter

- a. The thickness of the new valve lifter can be identified by the stamp mark (A) on the reverse side (inside the valve lifter).

NOTE:

Available thicknesses of the valve lifters (B) are: 7.88 - 8.40 mm (0.3102 - 0.3307 in), in 0.02 mm (0.0008 in) increments. Refer to [EM-135. "Camshaft"](#)

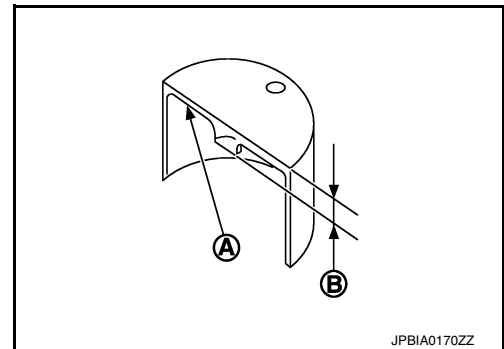

5. Install the selected replacement valve lifter.
6. Install the camshaft.
7. Rotate the crankshaft a few turns by hand.
8. Confirm that the valve clearances are within specification.
9. After the engine has been run to full operating temperature, confirm that the valve clearances are within specification.

| Standard Valve Clearance | Cold ¹ (reference data) | Hot ² (reference data) |
|--------------------------|------------------------------------|-------------------------------------|
| Intake | 0.26 - 0.34 mm (0.010 - 0.013 in) | 0.304 - 0.416 mm (0.012 - 0.016 in) |
| Exhaust | 0.29 - 0.37 mm (0.011 - 0.015 in) | 0.308 - 0.432 mm (0.012 - 0.017 in) |

¹ : Approximately 20°C (68°F)

² : Approximately 80°C (176°F)

COMPRESSION PRESSURE

< PERIODIC MAINTENANCE >

COMPRESSION PRESSURE

On-Vehicle Service

INFOID:000000011148369

CHECKING COMPRESSION PRESSURE

1. Run the engine until it reaches normal operating temperature.
2. Turn the ignition switch to OFF.
3. Release fuel pressure and leave the fuel pump electrically disconnected.
Refer to [EC-168, "Work Procedure"](#).
4. Remove all six spark plugs.
Refer to [EM-16, "Removal and Installation"](#).
5. Attach a compression tester to No. 1 cylinder.

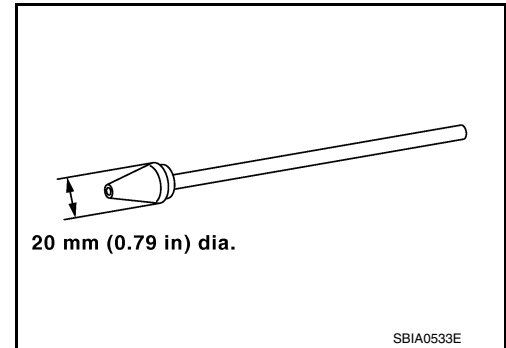

6. Depress accelerator pedal fully to keep the electric throttle control actuator butterfly-valve wide open to maximize air intake flow.
7. Crank the engine and record the highest gauge indication.
CAUTION:
Always use a fully charged battery to obtain specified engine speed.
8. Repeat the test for each cylinder (steps 5 - 7).

Unit: kPa (kg/cm², psi) /rpm

| Standard | Minimum | Differential limit between cylinders |
|-------------------------|-----------------------|--------------------------------------|
| 1,275 (13.0, 185) / 300 | 981 (10.0, 142) / 300 | 98 (1.0, 14) / 300 |

- If the engine speed is out of the specified range, check the battery and recharge as necessary. Check the engine speed again with the battery properly charged.
 - If some cylinders have low compression pressure, pour a small amount of engine oil into the spark plug hole of the cylinder to re-check it for compression.
 - If the added engine oil improves the compression, piston rings may be worn out or damaged. Check the piston rings and replace if necessary.
 - If the compression pressure remains at low level despite the addition of engine oil, the valves may be malfunctioning. Check the valves for damage. Replace the valve or valve seat accordingly.
 - If two adjacent cylinders have respectively low compression pressure and their compression remains low even after the addition of engine oil, cylinder head gaskets may be leaking, or a valve in adjacent cylinders may be damaged. Inspect and repair as required.
 - If the compression pressure is below the minimum value, check the valve clearances and parts associated with the combustion chamber (valve, valve seat, piston, piston ring, cylinder bore, cylinder head, cylinder head gasket). After the checking, measure the compression pressure again.
9. Installation of the remaining components is in the reverse order of removal.

ENGINE ROOM COVER

< REMOVAL AND INSTALLATION >

REMOVAL AND INSTALLATION

ENGINE ROOM COVER

Exploded View

INFOID:000000011148370

A

EM

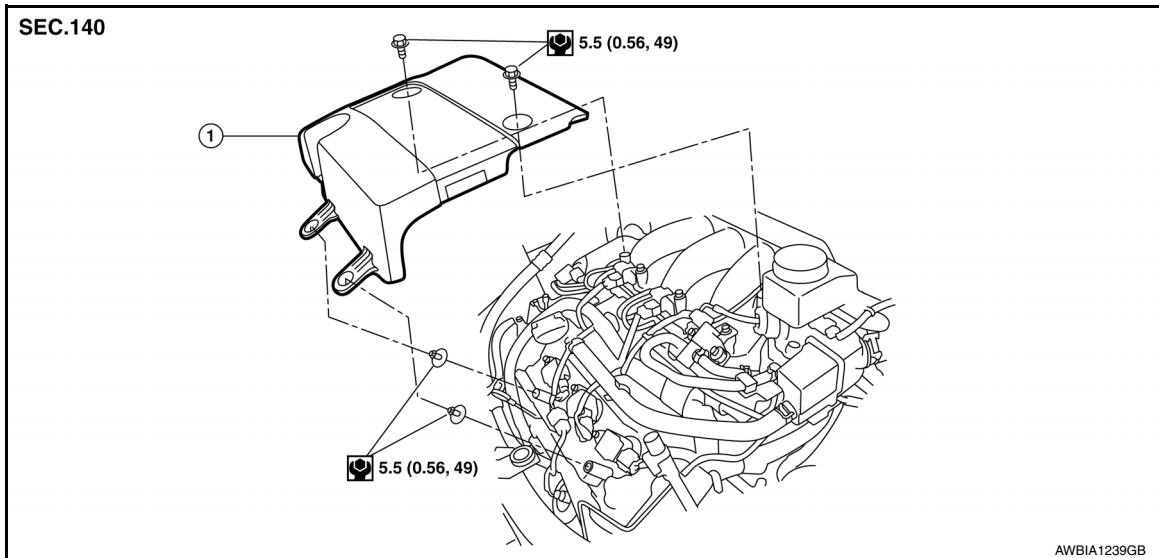

C

D

E

F

G

H

1. Engine room cover

Removal and Installation

INFOID:000000011148371

CAUTION:

Do not damage or scratch engine room cover when installing or removing.

REMOVAL

1. Remove front air duct. Refer to [EM-24. "Removal and Installation"](#).
2. Remove engine room cover bolts.
3. Remove engine room cover.

J

K

INSTALLATION

Installation is in the reverse order of removal.

L

M

N

O

P

AIR CLEANER AND AIR DUCT

< REMOVAL AND INSTALLATION >

AIR CLEANER AND AIR DUCT

Exploded View

INFOID:000000011148372

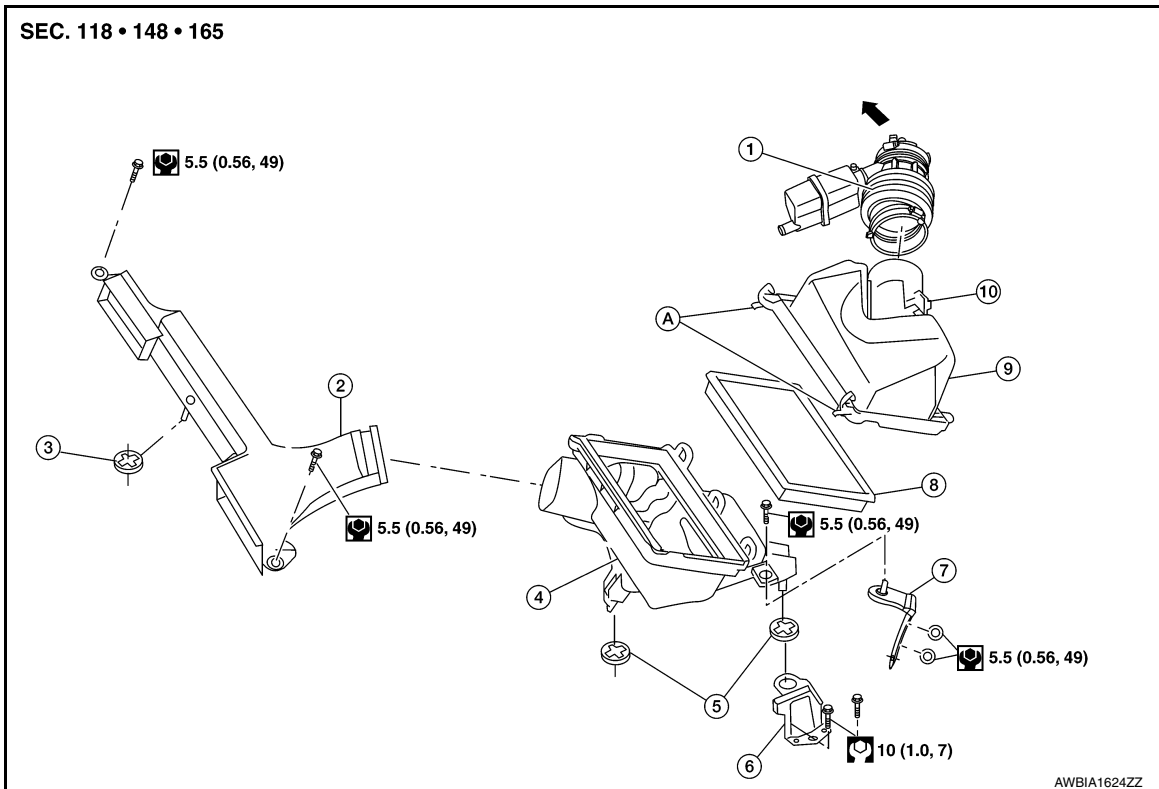

- | | | |
|---|--------------------------------|---|
| 1. Air duct hose and resonator assembly | 2. Front air duct | 3. Grommet |
| 4. Air cleaner case (lower) | 5. Grommets | 6. Air cleaner case mounting bracket |
| 7. Bracket | 8. Air cleaner filter | 9. Air cleaner case (upper) |
| 10. Mass air flow sensor | A. Air cleaner case side clips | ← To electric throttle control actuator clips |

Removal and Installation

INFOID:000000011148373

REMOVAL

1. Remove front air duct.
2. Disconnect the tube clamp at the electric throttle control actuator and at the air duct hose and resonator assembly.
3. Disconnect the blow-by hose. Refer to [EM-43. "Exploded View"](#)
4. Remove air duct hose and resonator assembly.
5. Disconnect mass air flow sensor.
6. Remove mass air flow sensor from air cleaner case (upper), as necessary.
CAUTION:
Handle mass air flow sensor with care.
 - Do not shock it.
 - Do not disassemble it.
 - Do not touch its sensor.
7. Disconnect the transaxle breather hose. Refer to [TM-200. "Removal and Installation"](#)
8. Remove bolts and pull air cleaner case (lower) upward to remove from the grommets.
9. Remove air cleaner assembly.

INSPECTION AFTER REMOVAL

AIR CLEANER AND AIR DUCT

< REMOVAL AND INSTALLATION >

Inspect air cleaner case (upper), air cleaner case (lower), front air duct, air duct and resonator assembly for cracks or tears. Replace as necessary.

A

INSTALLATION

Installation is in the reverse order of removal.

EM

C

D

E

F

G

H

I

J

K

L

M

N

O

P

INTAKE MANIFOLD COLLECTOR

< REMOVAL AND INSTALLATION >

INTAKE MANIFOLD COLLECTOR

Exploded View

INFOID:000000011148374

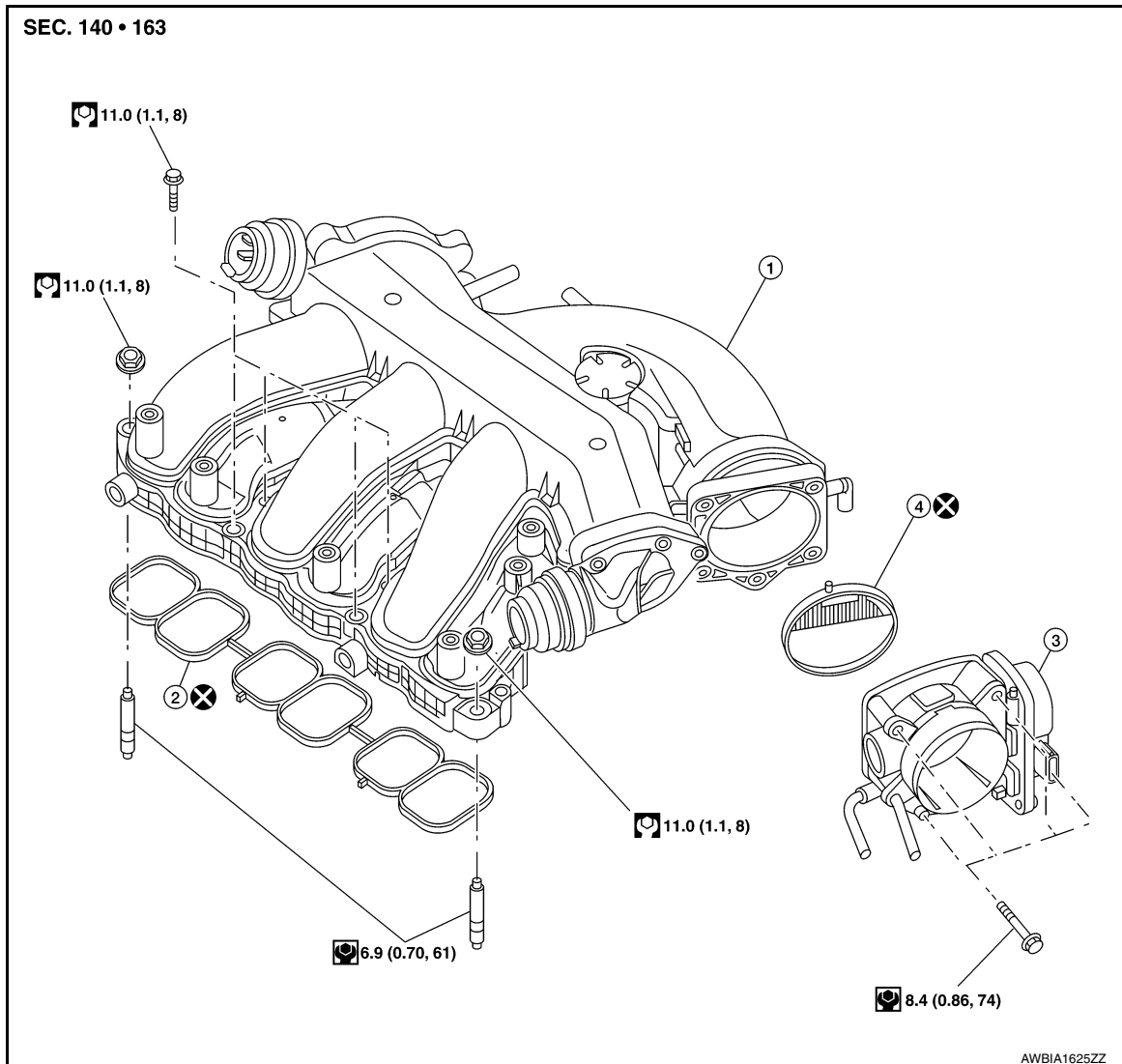

- 1. Intake manifold collector
- 2. Intake manifold collector gasket
- 3. Electric throttle control actuator
- 4. Electric throttle control actuator gasket

Removal and Installation

INFOID:000000011148375

WARNING:

Do not drain the engine coolant when the engine is hot to avoid the danger of being scalded.

CAUTION:

Do not remove power valves.

NOTE:

When removing components such as hoses, tubes/lines, etc., cap or plug openings to prevent fluid from spilling.

REMOVAL

CAUTION:

Cover engine openings to avoid the entry of any foreign material.

1. Disconnect the negative battery terminal. Refer to [PG-98, "Exploded View"](#).
2. Remove the cowl top cover and the cowl top extension. Refer to [EXT-25, "Exploded View"](#).

INTAKE MANIFOLD COLLECTOR

< REMOVAL AND INSTALLATION >

3. Remove engine room cover. Refer to [EM-23. "Removal and Installation"](#).
4. Remove the air cleaner case (upper), air cleaner case (lower), and air duct and resonator assembly. Refer to [EM-24. "Removal and Installation"](#).
5. Disconnect the power brake booster vacuum hose.
6. Disconnect engine mount control valve solenoid harness connector. Refer to [EC-27. "Electronic Controlled Engine Mount"](#).
7. Disconnect VIAS control solenoid valve harness connector. Refer to [EC-34. "VIAS Control Solenoid Valve 1 and 2"](#).
8. Disconnect the PCV hose.
9. Disconnect the electric throttle control actuator electrical harness connector.
10. Disconnect the EVAP canister purge volume control solenoid valve hose.
11. Remove the electric throttle control actuator bolts and remove the electric throttle control actuator and position aside. Loosening is done in reverse order of torquing.

CAUTION:

- Handle carefully to avoid any shock to the electric throttle control actuator.
- Do not disassemble.

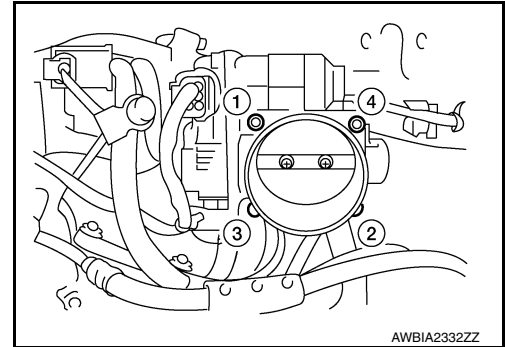

12. Remove the VIAS control solenoid valve as necessary.
13. Remove the EVAP canister purge volume control solenoid valve.
14. Loosen the intake manifold collector bolts and remove the intake manifold collector and gasket. Loosening is done in reverse order of torquing.

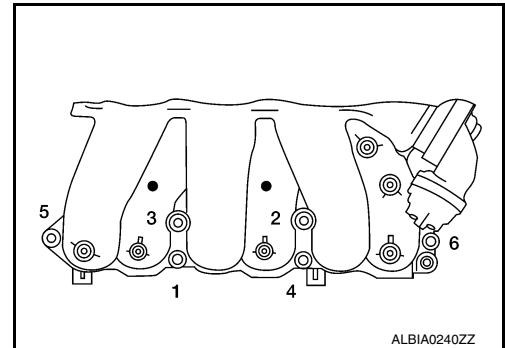

INSTALLATION

Installation is in the reverse order of removal.

- Tighten intake manifold collector bolts in the order as shown.

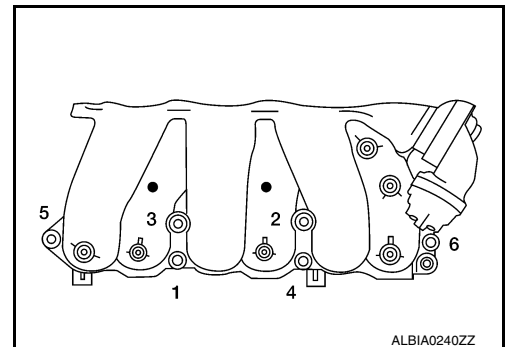

INTAKE MANIFOLD COLLECTOR

< REMOVAL AND INSTALLATION >

- Tighten electric throttle control actuator bolts in the order shown.

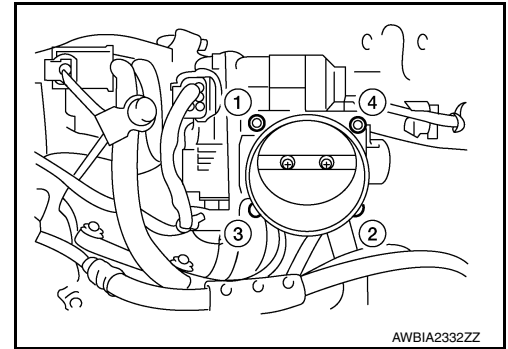

AWBIA2332ZZ

NOTE:

After installation, re-calibrate the electric throttle control actuator as follows:

1. Perform the "Throttle Valve Closed Position Learning" when harness connector of the electric throttle control actuator is disconnected. Refer to [EC-159, "Work Procedure"](#).
2. Perform the "Idle Air Volume Learning" when the electric throttle control actuator is replaced. Refer to [EC-160, "Work Procedure"](#).
3. Perform the "Accelerator Pedal Released Position Learning" when the electric throttle control actuator is replaced. Refer to [EC-158, "Work Procedure"](#).

INTAKE MANIFOLD

< REMOVAL AND INSTALLATION >

INTAKE MANIFOLD

Exploded View

INFOID:000000011148376

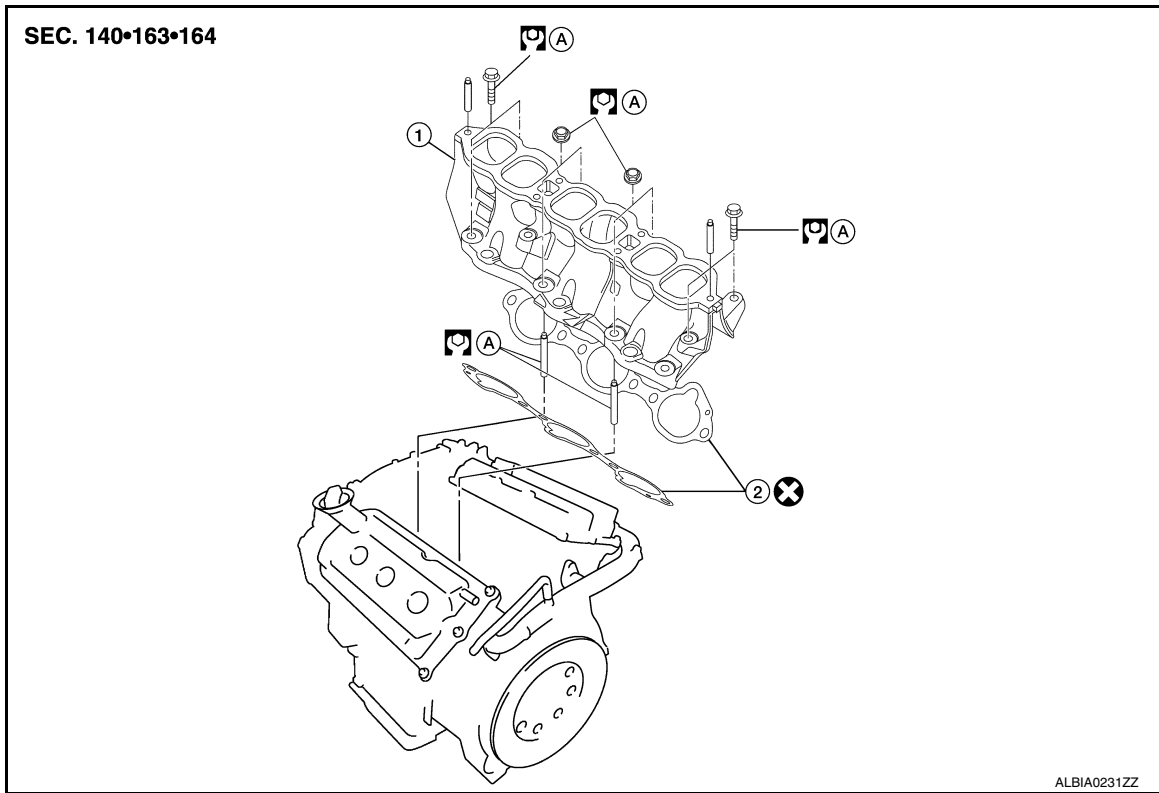

1. Intake manifold 2. Intake manifold gasket A. Refer to INSTALLATION

Removal and Installation

INFOID:000000011148377

REMOVAL

WARNING:

Do not drain the engine coolant when the engine is hot to avoid the danger of being scalded.

1. Remove the fuel injectors and fuel tube as a unit from the intake manifold. Refer to [EM-47, "Removal and Installation"](#).
2. Remove the engine mount control valve solenoid vacuum hose.
3. Remove VIAS control solenoid valve vacuum hoses.
4. Remove the EVAP canister purge volume control solenoid valve vacuum pipes and hoses.
5. Remove the vacuum gallery.
6. Remove the electric throttle control actuator coolant hoses.
7. Remove the intake manifold and gaskets. Loosening is done in reverse order of torquing.

CAUTION:

Cover the engine openings to avoid the entry of foreign materials.

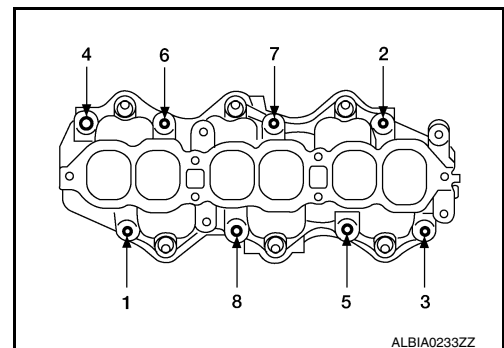

INTAKE MANIFOLD

< REMOVAL AND INSTALLATION >

INSPECTION AFTER REMOVAL

Surface Distortion

- Using straightedge and feeler gauge, inspect the surface distortion of the intake manifold. Refer to [EM-135, "Intake Manifold"](#).

Standard : 0.1 mm (0.004 in)

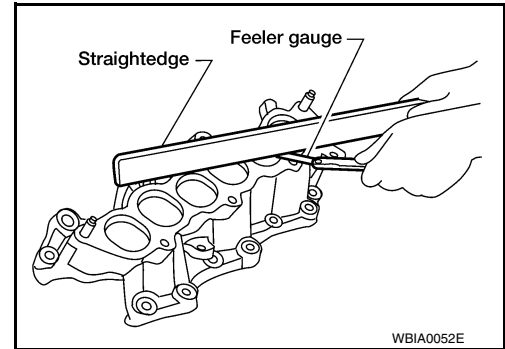

INSTALLATION

Installation is in the reverse order of removal. Follow the procedure below for specific tightening sequences and procedures.

CAUTION:

Install the gaskets with the painted surface facing the intake manifold side.

- Install intake manifold studs, (if removed) and tighten to specification.

Intake manifold studs : 10.8 N·m (1.1 kg·m, 8 ft·lb)

- Install intake manifold bolts in two steps in the numerical order as shown.

Step 1 : 7.4 N·m (0.75 kg·m, 65 in·lb)

Step 2 : 25.5 N·m (2.6 kg·m, 19 ft·lb)

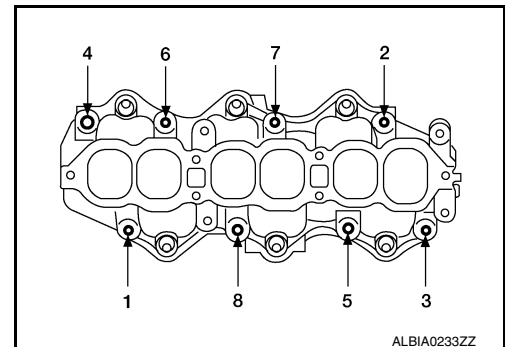

INSPECTION AFTER INSTALLATION

Make sure there are no fuel leaks at connections as follows:

- Apply fuel pressure to fuel lines by turning ignition switch ON with engine stopped. Then check for fuel leaks at connections.
- Start the engine and rev it up and check for fuel leaks at connections.

WARNING:

Do not touch engine immediately after stopping, as engine is extremely hot.

NOTE:

Use mirrors for checking on connections out of the direct line of sight.

EXHAUST MANIFOLD AND THREE WAY CATALYST

< REMOVAL AND INSTALLATION >

EXHAUST MANIFOLD AND THREE WAY CATALYST

Exploded View

INFOID:000000011148378

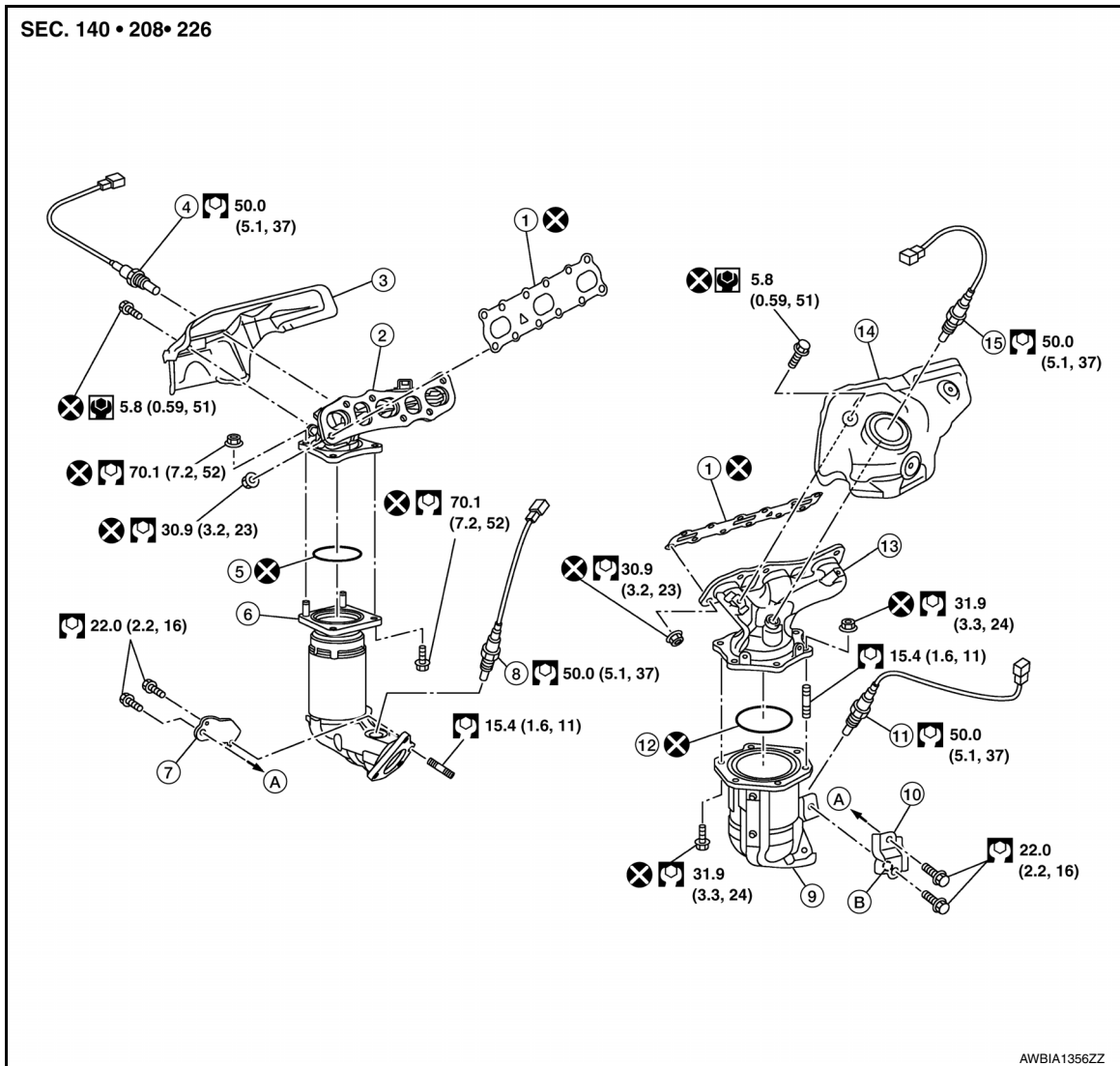

- | | | |
|---|-------------------------------------|--------------------------------------|
| 1. Gasket | 2. Exhaust manifold (bank 1) | 3. Exhaust manifold cover (bank 1) |
| 4. Air fuel ratio sensor 1 (bank 1) | 5. Ring gasket | 6. Three way catalyst (bank 1) |
| 7. Three way catalyst support (bank 1) | 8. Heated oxygen sensor 2 (bank 1) | 9. Three way catalyst (bank 2) |
| 10. Three way catalyst support (bank 2) | 11. Heated oxygen sensor 2 (bank 2) | 12. Ring gasket |
| 13. Exhaust manifold (bank 2) | 14. Exhaust manifold cover (bank 2) | 15. Air fuel ratio sensor 1 (bank 2) |
| A. To oil pan (upper) | B. Upper mark | |

Removal and Installation (bank 2)

INFOID:000000011148379

REMOVAL

WARNING:

- Perform the work when the exhaust system has completely cooled down.
- When removing the front and rear engine mount through bolts and nuts, lift the engine up slightly for safety.

NOTE:

When removing components such as hoses, tubes/lines, etc., cap or plug openings to prevent fluid from spilling.

EXHAUST MANIFOLD AND THREE WAY CATALYST

< REMOVAL AND INSTALLATION >

1. Remove the air cleaner case (upper), air cleaner case (lower), and air duct hose and resonator assembly. Refer to [EM-24, "Removal and Installation"](#).
2. Remove the battery and battery tray assembly. Refer to [PG-97, "Removal and Installation"](#).
3. Remove transaxle breather tube. Refer to [TM-200, "Removal and Installation"](#).
4. Remove the front wheels and tires using a power tool. Refer to [WT-58, "Adjustment"](#).
5. Remove the front under cover. Refer to [EXT-16, "Exploded View"](#).
6. Remove the fender protector side covers (LH and RH). Refer to [EXT-16, "Exploded View"](#).
7. Remove the fan shroud and motor assembly. Refer to [CO-17, "Removal and Installation"](#).
8. Remove the radiator assembly. Refer to [CO-15, "Removal and Installation"](#).
9. Remove the front exhaust tube. Refer to [EX-5, "Exploded View"](#).
10. Support the engine with a suitable tool.
11. Remove the engine mount bracket (front). Refer to [EM-103, "2WD : Exploded View"](#) (2WD) or [EM-107, "4WD : Exploded View"](#) (4WD).
12. Remove the three way catalyst support (bank 2).
13. Remove heated oxygen sensor 2 (bank 2), air fuel ratio (A/F) sensor 1 (bank 2).
 - a. Remove harness connector of each sensor, and disconnect the harness from the bracket and middle clamp.
 - b. Remove both heated oxygen sensor and air fuel ratio (A/F) sensor using Tool.

Tool numbers : KV10114400 (J-38365)
: KV991J0050 (J-44626)

CAUTION:

- Be careful not to damage heated oxygen sensors or air fuel ratio (A/F) sensors.
- Discard any heated oxygen sensor which has been dropped from a height of more than 0.5 m (19.7 in) onto a hard surface such as a concrete floor; replace with a new sensor.

14. Remove exhaust manifold and three way catalyst heat shields with power tool.
15. Remove the three way catalyst (bank 2) by loosening the bolts first and then removing the nuts and through bolts.
16. Loosen and remove the exhaust manifold nuts (bank 2) in the reverse order as shown.

← : Engine front

NOTE:

Number 7 and 8 are not applicable to removal.

17. Remove the exhaust manifold (bank 2) and gasket.

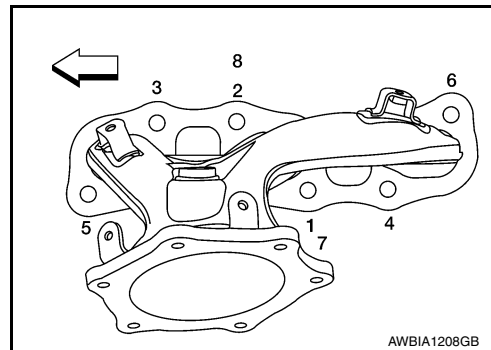

INSPECTION AFTER REMOVAL

Surface Distortion

- Use a reliable straightedge and feeler gauge to check the flatness of the exhaust manifold mating surfaces.

Limit : 0.3 mm (0.012 in)

- Replace the exhaust manifold if the measurement exceeds specifications.

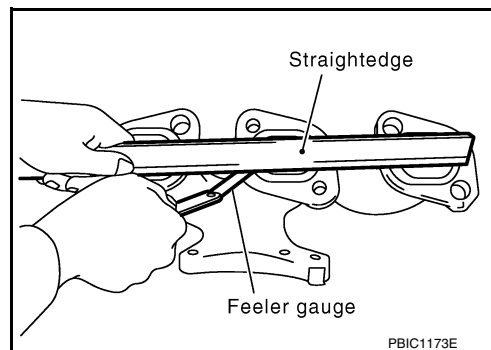

INSTALLATION

EXHAUST MANIFOLD AND THREE WAY CATALYST

< REMOVAL AND INSTALLATION >

Installation is in the reverse order of removal.

1. Install the studs in the exhaust manifold (if removed), and tighten to specification.

Exhaust manifold studs : 15.4 N·m (1.6 kg-m, 11 ft-lb)

2. Install the exhaust manifold gasket in the direction shown.

- (A) : Bank 1
(B) : Triangle press
(C) : Bank 2
⇐ : Engine front

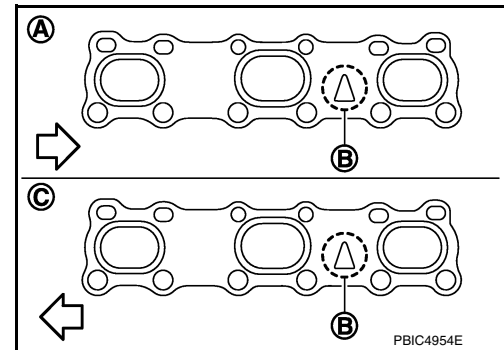

3. Install the exhaust manifold (bank 2) nuts and tighten to specification in the order shown.

⇐ : **Engine front**

NOTE:

Number 7 and 8 are tightened a second time.

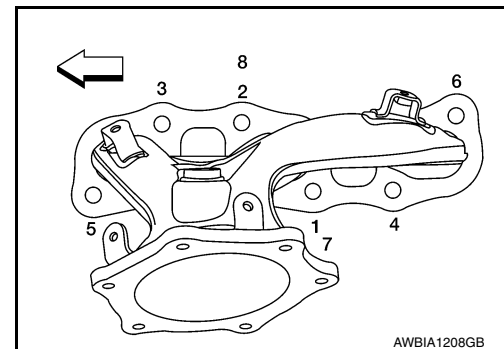

CAUTION:

- Before installing a heated oxygen sensor or air fuel ratio (A/F) sensor, clean the exhaust manifold threads using the oxygen sensor thread cleaner tool and apply anti-seize lubricant.

Oxygen sensor thread cleaner : — (J-43897-18)

Oxygen sensor thread cleaner : — (J-43897-12)

- Do not over-tighten the air fuel ratio (A/F) sensor or heated oxygen sensors. Doing so may cause damage.

Tool numbers : KV10114400 (J-38365)

: KV991J0050 (J-44626)

Removal and Installation (bank 1)

INFOID:000000011148380

REMOVAL

WARNING:

- Perform the work when the exhaust system has completely cooled down.
- When removing the front and rear engine mounting through bolts and nuts, lift the engine up slightly for safety.

NOTE:

When removing components such as hoses, tubes/lines, etc., cap or plug openings to prevent fluid from spilling.

1. Remove the cowl top grille and the lower cowl top extension. Refer to [EXT-25, "Exploded View"](#).
2. Remove the right front wheel and tire (4WD models only) using a power tool. Refer to [WT-58, "Adjustment"](#).
3. Remove the front under cover. Refer to [EXT-16, "Exploded View"](#).
4. Remove the fender protector side cover (4WD models only). Refer to [EXT-16, "Exploded View"](#).

EXHAUST MANIFOLD AND THREE WAY CATALYST

< REMOVAL AND INSTALLATION >

5. Remove transmission air breather hose. Refer to [TM-200, "Removal and Installation"](#).
6. Remove the front exhaust tube, hanger and heat insulator. Refer to [EX-5, "Exploded View"](#).
7. Remove the propeller shaft and propeller shaft center bearing (4WD models only). Refer to [DLN-102, "Removal and Installation"](#).
8. Remove the RH front axle shaft (4WD models only). Refer to [FAX-18, "Removal and Installation \(RH\)"](#).
9. Remove the RH three way catalyst support brackets.
10. Remove heated oxygen sensor 2 (bank 1), air fuel ratio (A/F) sensor 1 (bank 1).
 - a. Remove harness connector of each sensor, and disconnect the harness from the bracket and middle clamp.
 - b. Remove both heated oxygen sensors and air fuel ratio (A/F) sensors using Tool.

Tool numbers : KV10114400 (J-38365)
: KV991J0050 (J-44626)

CAUTION:

- Be careful not to damage heated oxygen sensors or air fuel ratio (A/F) sensors.
- Discard any heated oxygen sensor which has been dropped from a height of more than 0.5 m (19.7 in) onto a hard surface such as a concrete floor; replace with a new sensor.

11. Remove exhaust manifold and three way catalyst heat shields with power tool.
12. Remove the three way catalyst (bank 1) by loosening the bolts first and then removing the nuts and through bolts.
13. Loosen the exhaust manifold nuts in the reverse order as shown.

⇐ : Engine front

NOTE:

Number 7 and 8 are not applicable to removal.

14. Remove the exhaust manifold (bank 1) and gasket.

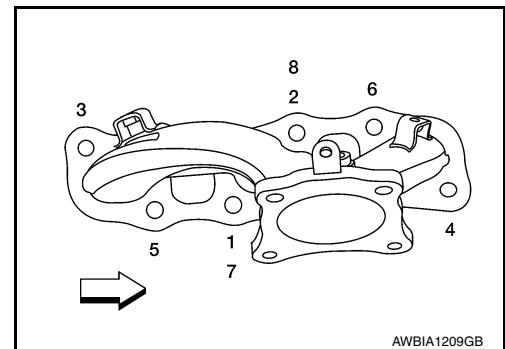

INSPECTION AFTER REMOVAL

Surface Distortion

- Use a reliable straightedge and feeler gauge to check the flatness of the exhaust manifold mating surfaces.

Limit : 0.3 mm (0.012 in)

- Replace the exhaust manifold if the measurement exceeds specifications.

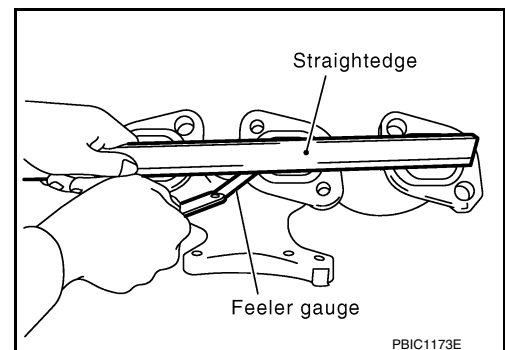

INSTALLATION

Installation is in the reverse order of removal.

1. Install the studs in the exhaust manifold (if removed), and tighten to specification.

Exhaust manifold studs : 15.4 N·m (1.6 kg-m, 11 ft-lb)

EXHAUST MANIFOLD AND THREE WAY CATALYST

< REMOVAL AND INSTALLATION >

2. Install the exhaust manifold gasket in the direction shown.

- (A) : Bank 1
- (B) : Triangle press
- (C) : Bank 2
- ← : Engine front

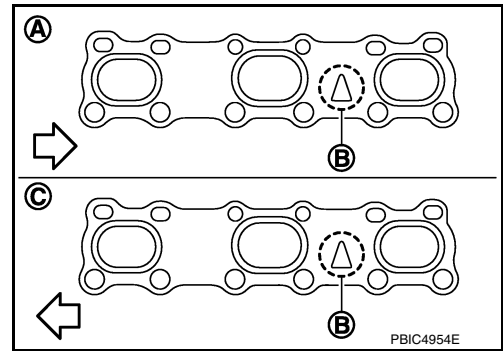

3. Install the exhaust manifold (bank 1) nuts and tighten to specification in the order shown.

- ← : Engine front

NOTE:

Number 7 and 8 are tightened a second time.

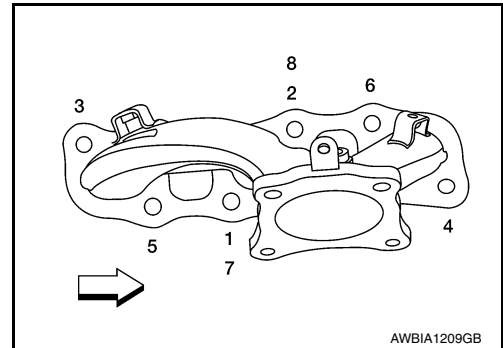

CAUTION:

- Before installing a heated oxygen sensor or air fuel ratio (A/F) sensor, clean the exhaust manifold threads using the oxygen sensor thread cleaner tool and apply anti-seize lubricant.

Oxygen sensor thread cleaner : — (J-43897-18)

Oxygen sensor thread cleaner : — (J-43897-12)

- Do not over-tighten the air fuel ratio (A/F) sensor or heated oxygen sensors. Doing so may cause damage.

Tool numbers : KV10114400 (J-38365)

: KV991J0050 (J-44626)

OIL PAN AND OIL STRAINER

< REMOVAL AND INSTALLATION >

OIL PAN AND OIL STRAINER

Exploded View

INFOID:000000011148381

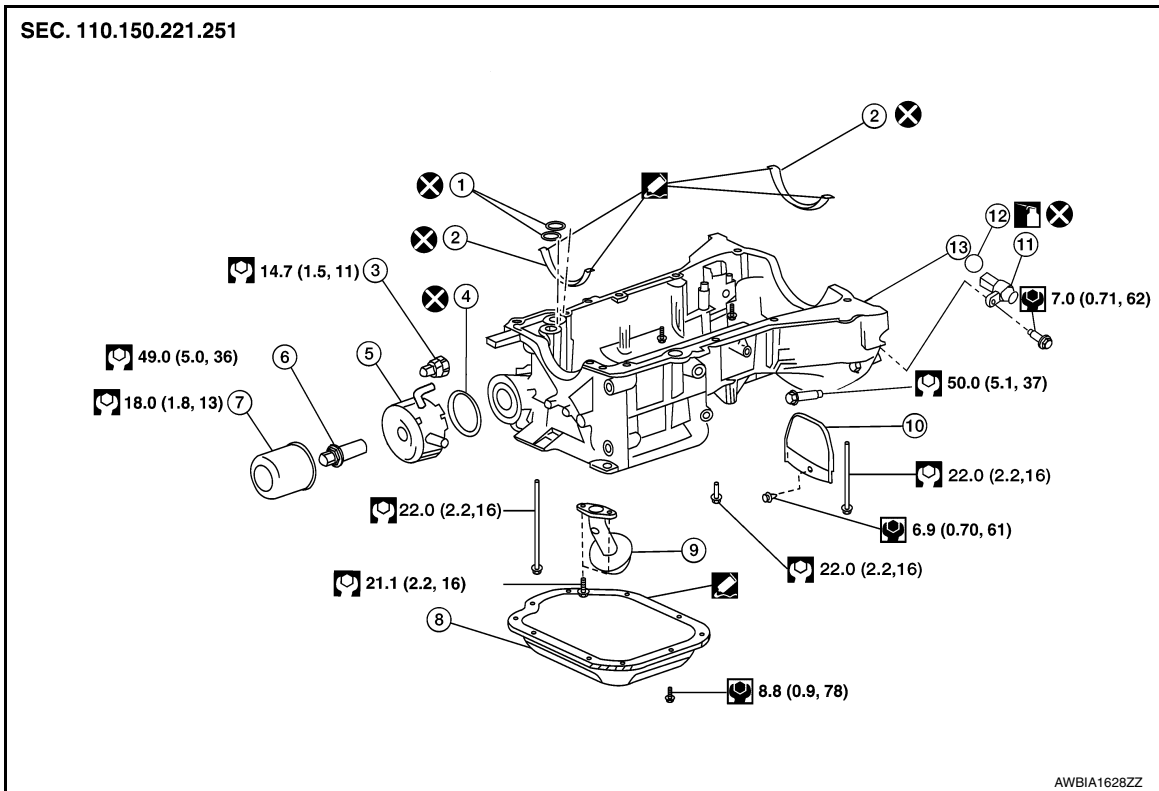

- | | | |
|----------------------|---|--------------------------|
| 1. O-ring | 2. Front cover gasket and rear oil seal retainer gasket | 3. Oil pressure switch |
| 4. Oil cooler gasket | 5. Oil cooler | 6. Oil cooler connection |
| 7. Oil filter | 8. Lower oil pan | 9. Oil strainer |
| 10. Rear plate cover | 11. Crankshaft position sensor (POS) | 12. O-ring |
| 13. Upper oil pan | | |

Removal and Installation (Lower Oil Pan)

INFOID:000000011148382

REMOVAL

WARNING:

• You should not remove the oil pan until the exhaust system and cooling system have completely cooled off.

1. Drain the engine oil. Refer to [LU-9. "Changing Engine Oil"](#).
2. Loosen the lower oil pan bolts in reverse order as shown.

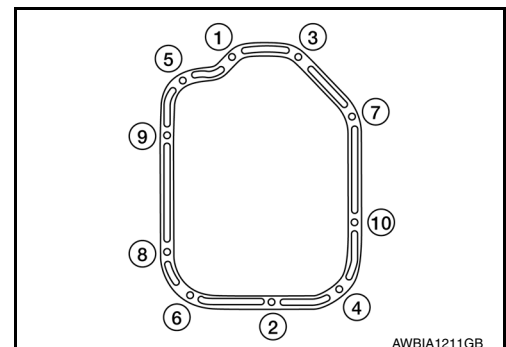

AWBIA1211GB

OIL PAN AND OIL STRAINER

< REMOVAL AND INSTALLATION >

- Remove the lower oil pan.
 - After removing the bolts, separate the mating surface and remove the old liquid gasket using Tool.

Tool number : KV10111100 (J-37228)

CAUTION:

Do not damage the mating surfaces.

- In areas where the Tool is difficult to use, use a plastic hammer to lightly tap (1) the Tool where the liquid gasket is applied. Use a plastic hammer to slide (2) the Tool by tapping on the side.

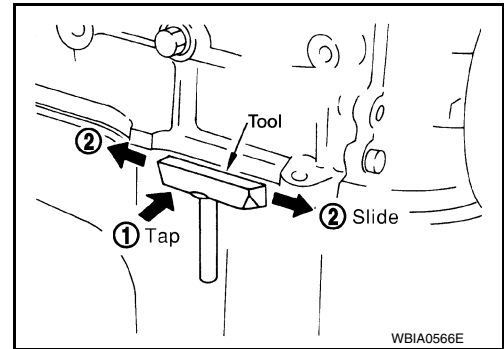

- Remove the old sealant from the bolt holes and threads.

INSPECTION AFTER REMOVAL

Clean debris from the oil strainer.

INSTALLATION

- Apply a continuous bead of sealant to the lower oil pan.
 - Use Genuine Silicone RTV Sealant, or equivalent. Refer to [GL-22. "Recommended Chemical Products and Sealants"](#).
 - Be sure the sealant is 4.5 - 5.5 mm (0.177 - 0.217 in) wide.

CAUTION:

- Installation should be done within 5 minutes after applying liquid gasket.
- Do not fill the engine with engine oil for at least 30 minutes after the components are installed to allow the sealant to cure.

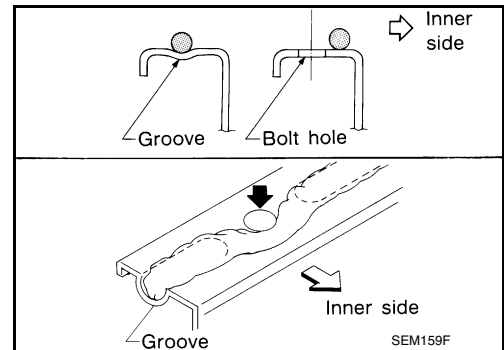

- Install the lower oil pan. Tighten the lower oil pan bolts in order as shown.

CAUTION:

- Installation should be done within 5 minutes after applying liquid gasket.
- Do not fill the engine with engine oil for at least 30 minutes after the components are installed to allow the sealant to cure.

- Refill the engine with engine oil. Refer to [LU-9. "Changing Engine Oil"](#).

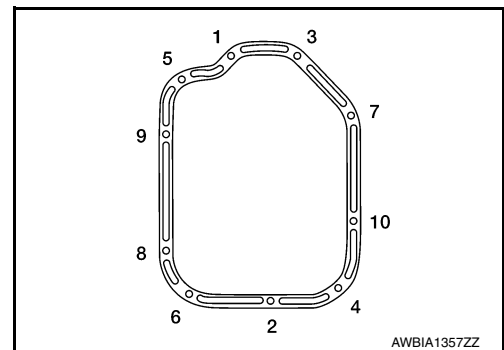

INSPECTION AFTER INSTALLATION

- Inspect the engine oil level. Refer to [LU-8. "Inspection"](#).
- Start the engine and check for leaks. Refer to [LU-8. "Inspection"](#). Repair as necessary.

Removal and Installation (Upper Oil Pan)

INFOID:000000011148383

REMOVAL

WARNING:

- Do not remove the oil pan until the exhaust system and cooling system have completely cooled off.
- When removing the front and rear engine through bolts and nuts, lift the engine up slightly for safety.

CAUTION:

When removing the upper oil pan from the engine, first remove the crankshaft position sensor (POS). Be careful not to damage sensor edges or signal plate teeth.

NOTE:

When removing components such as hoses, tubes/lines, etc., cap or plug openings to prevent fluid from spilling.

OIL PAN AND OIL STRAINER

< REMOVAL AND INSTALLATION >

1. Remove the engine from the vehicle. Refer to [EM-103. "2WD : Removal and Installation"](#) (2WD models) or [EM-108. "4WD : Removal and Installation"](#) (4WD models).
2. Remove the oil dipstick.
3. Remove the drive belt. Refer to [EM-12. "Removal and Installation"](#).
4. Disconnect the A/C compressor harness connector.
5. Remove the A/C compressor bolts and remove the A/C compressor. Refer to [HA-30. "COMPRESSOR : Removal and Installation"](#).
6. Remove coolant pipe bolts.
7. Disconnect the coolant hoses from the engine oil cooler.
8. Remove the oil filter and engine oil cooler from the upper oil pan. Refer to [LU-15. "Removal and Installation"](#).
9. Remove the oil pressure switch, and the crankshaft position sensor (POS) from the upper oil pan.
10. Remove the lower oil pan. Refer to [EM-36. "Removal and Installation \(Lower Oil Pan\)"](#).
11. Remove the oil strainer.
12. Remove the upper oil pan.
 - a. Loosen the bolts in the reverse order shown using a power tool.

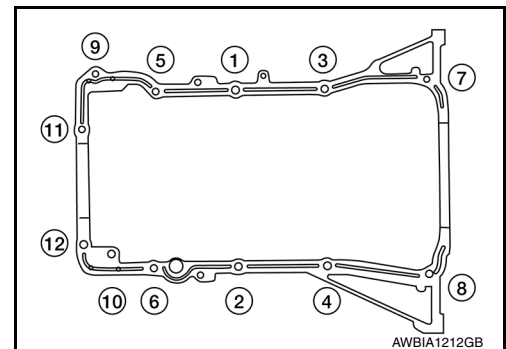

- b. Insert an appropriate size tool into the notch (1) of the upper oil pan as shown.
- c. Pry off the upper oil pan by moving the tool up and down (2) as shown.

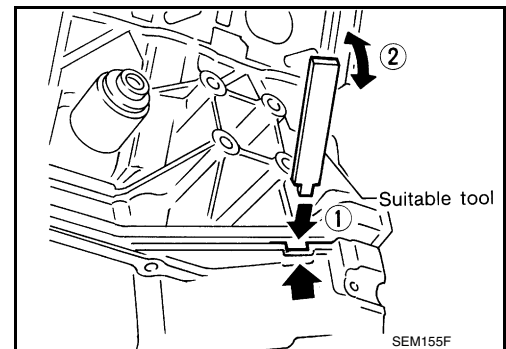

13. Remove the O-ring seals from the bottom of the cylinder block and oil pump housing. Use new O-rings for installation.

CAUTION:

Do not reuse O-rings.

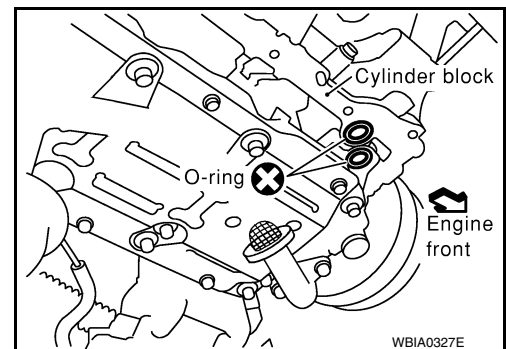

OIL PAN AND OIL STRAINER

< REMOVAL AND INSTALLATION >

14. Remove front cover gasket and rear oil seal retainer gasket.

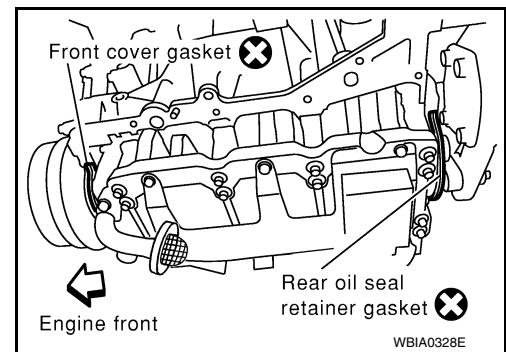

15. If re-installing the original oil pan, remove the old sealant from the mating surfaces using a scraper.

- Also remove the old sealant from mating surface of the cylinder block.
- Remove the old sealant from the bolt holes and threads.

CAUTION:

Do not scratch or damage the mating surfaces when cleaning off the old sealant.

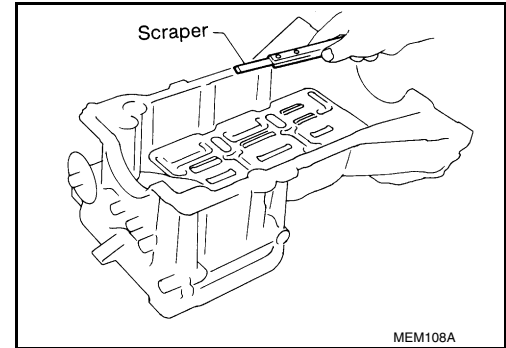

INSPECTION AFTER REMOVAL

Clean debris from oil strainer.

INSTALLATION

1. Install oil strainer and tighten bolt to specified torque. Refer to [EM-36, "Exploded View"](#).

2. Apply Genuine Silicone RTV Sealant or equivalent to the front cover gasket and the rear oil seal retainer gasket as shown. Refer to [GI-22, "Recommended Chemical Products and Sealants"](#).

CAUTION:

- Installation should be done within 5 minutes after applying liquid gasket.
- Do not fill the engine with engine oil for at least 30 minutes after the components are installed to allow the sealant to cure.

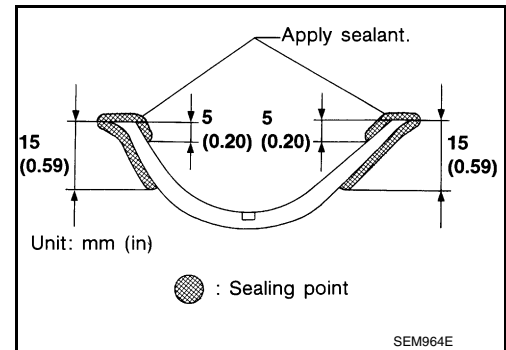

3. Install the front cover gasket and rear oil seal retainer gasket as shown.

CAUTION:

Do not reuse front cover gasket or rear oil seal retainer gasket.

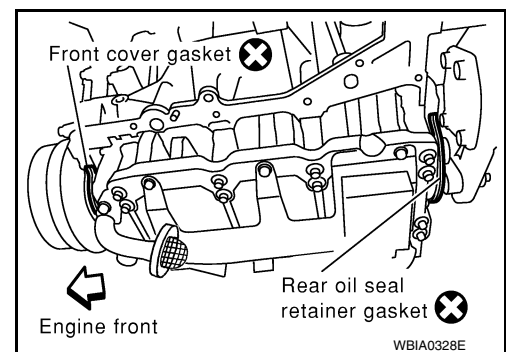

OIL PAN AND OIL STRAINER

< REMOVAL AND INSTALLATION >

4. Apply a bead of sealant to the cylinder block mating surface of the upper oil pan as shown.

CAUTION:

- Installation should be done within 5 minutes after applying liquid gasket.
- Do not fill the engine with engine oil for at least 30 minutes after the components are installed to allow the sealant to cure.

NOTE:

- Apply liquid gasket to the outside of bolt holes 5, 6, 10, 11 and 12.
- Apply liquid gasket to the inside of the other bolt holes.

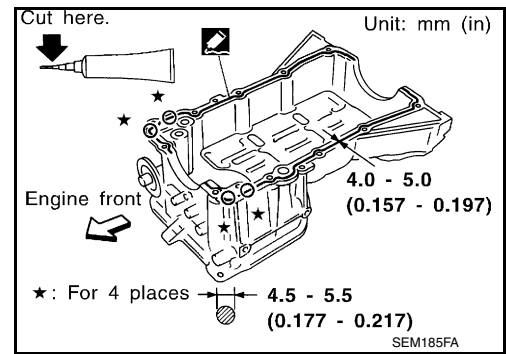

- a. Be sure the sealant is applied 4.0 - 5.0 mm (0.157 - 0.197 in) as shown. Increase the bead to 4.5 - 5.5 mm (0.177 - 0.217 in) at the four places indicated.
- b. Use Genuine Silicone RTV Sealant, or equivalent. Refer to [GI-22. "Recommended Chemical Products and Sealants"](#).

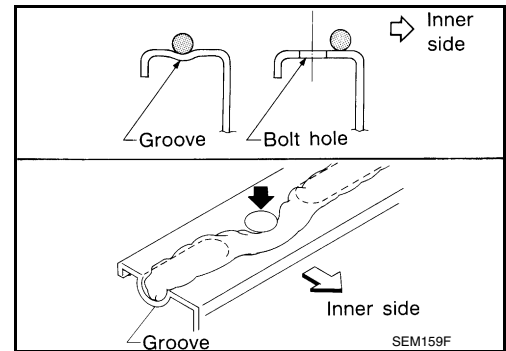

5. Install new O-rings on the cylinder block and oil pump body.

CAUTION:

Do not reuse O-rings.

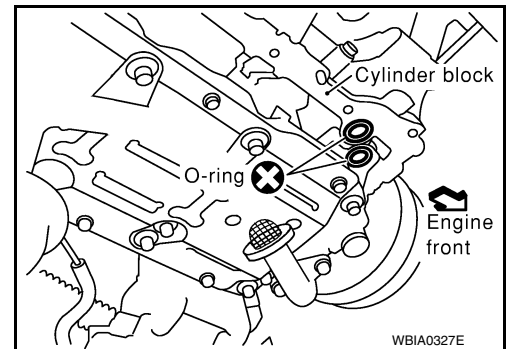

6. Install the upper oil pan.
- Tighten bolts (1) and (2) to specification within five minutes of applying the liquid gasket.
 - Tighten the remaining upper oil pan bolts to specification in the order shown.

CAUTION:

- Installation should be done within 5 minutes after applying liquid gasket.
- Do not fill the engine with engine oil for at least 30 minutes after the components are installed to allow the sealant to cure.

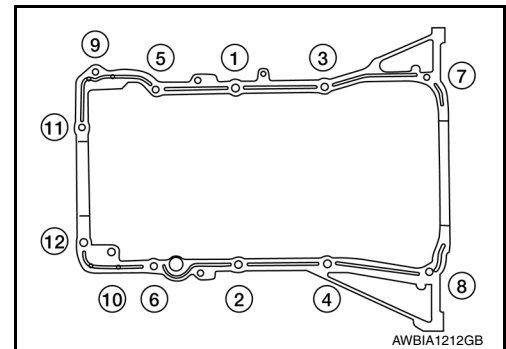

7. Install the lower oil pan. Refer to [EM-36. "Removal and Installation \(Lower Oil Pan\)"](#).

8. Installation of the remaining components is in the reverse order of removal.

INSPECTION AFTER INSTALLATION

- Before starting engine, check oil/fluid levels including engine coolant and engine oil. If there is less than required quantity, fill to the specified level. Refer to [MA-15. "FOR USA AND CANADA : Fluids and Lubricants"](#) (United States and Canada) or [MA-17. "FOR MEXICO : Fluids and Lubricants"](#) (Mexico).
- Use procedure below to check for fuel leaks.
- Turn ignition switch ON (with engine stopped). With fuel pressure applied to fuel piping, check for fuel leaks at connection points.

OIL PAN AND OIL STRAINER

< REMOVAL AND INSTALLATION >

- Start engine. With engine speed increased, check again for fuel leaks at connection points.
- Run engine to check for unusual noise and vibration.

A

NOTE:

If hydraulic pressure inside timing chain tensioner drops after removal and installation, slack in the guide may generate a pounding noise during and just after engine start. However, this is normal. Noise will stop after hydraulic pressure rises.

EM

- Warm up engine thoroughly to make sure there are no leaks of fuel, exhaust gas, or any oils/fluids including engine oil and engine coolant.
- Bleed air from passages in lines and hoses, such as in cooling system.
- After cooling down engine, again check oil/fluid levels including engine oil and engine coolant. Refill to specified level, if necessary.
- Summary of the inspection items:

C

D

| Item | | Before starting engine | Engine running | After engine stopped |
|------------------------|------------|------------------------|----------------|----------------------|
| Engine coolant | | Level | Leaks | Level |
| Engine oil | | Level | Leaks | Level |
| Transaxle Fluid | CVT Models | Leaks | Level/Leaks | Leaks |
| | | Level/Leaks | Leaks | Level/Leaks |
| Other oils and fluids* | | Level | Leaks | Level |
| Fuel | | Leaks | Leaks | Leaks |
| Exhaust gas | | — | Leaks | — |

E

F

G

*Power steering fluid, brake fluid, etc.

H

I

J

K

L

M

N

O

P

IGNITION COIL

< REMOVAL AND INSTALLATION >

IGNITION COIL

Exploded View

INFOID:0000000011148384

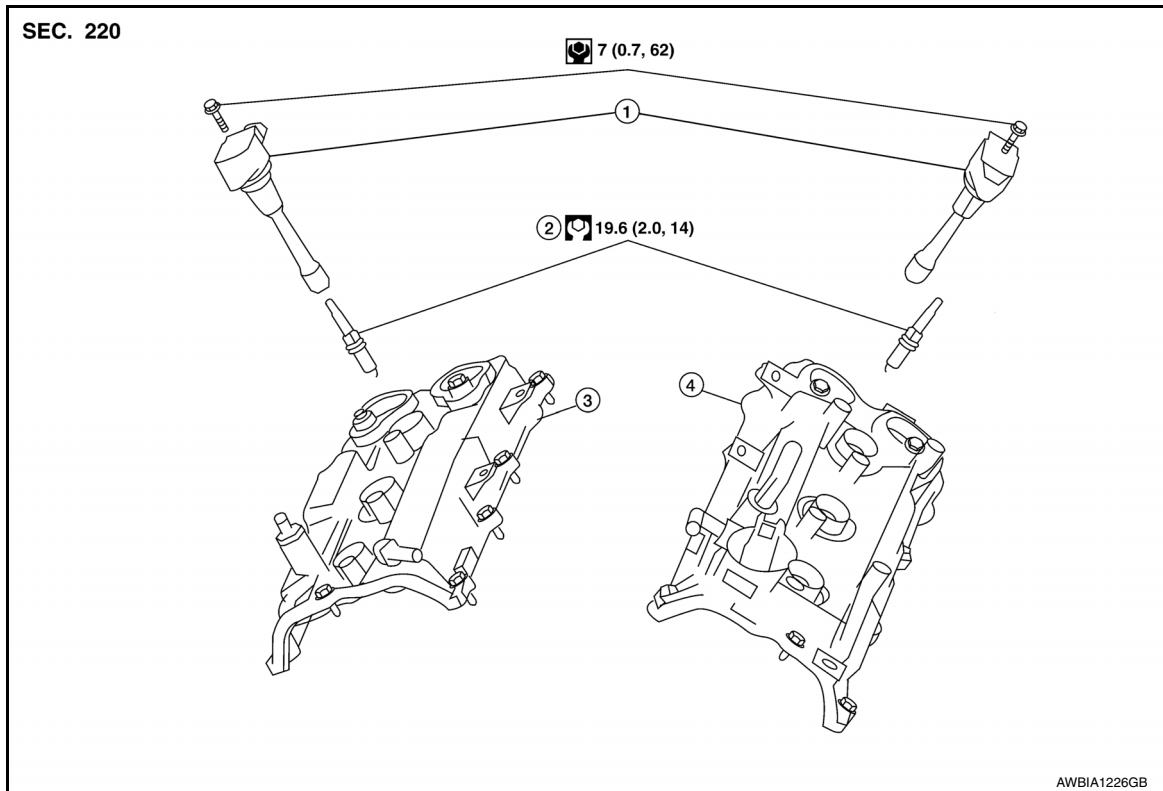

1. Ignition coil
2. Spark plug
3. Rocker cover (RH)
4. Rocker cover (LH)

Removal and Installation (LH)

INFOID:0000000011148385

REMOVAL

1. Remove engine room cover. Refer to [EM-23. "Removal and Installation"](#).
2. Disconnect ignition coil harness connector.
3. Remove the ignition coil.

CAUTION:

Do not shock ignition coil.

INSTALLATION

Installation is in the reverse order of removal.

Removal and Installation (RH)

INFOID:0000000011148386

REMOVAL

1. Remove the intake manifold collector. Refer to [EM-26. "Removal and Installation"](#).
2. Disconnect ignition coil harness connector.
3. Remove the ignition coil.

CAUTION:

Do not shock ignition coil.

INSTALLATION

Installation is in the reverse order of removal.

ROCKER COVER

< REMOVAL AND INSTALLATION >

ROCKER COVER

Exploded View

INFOID:000000011148387

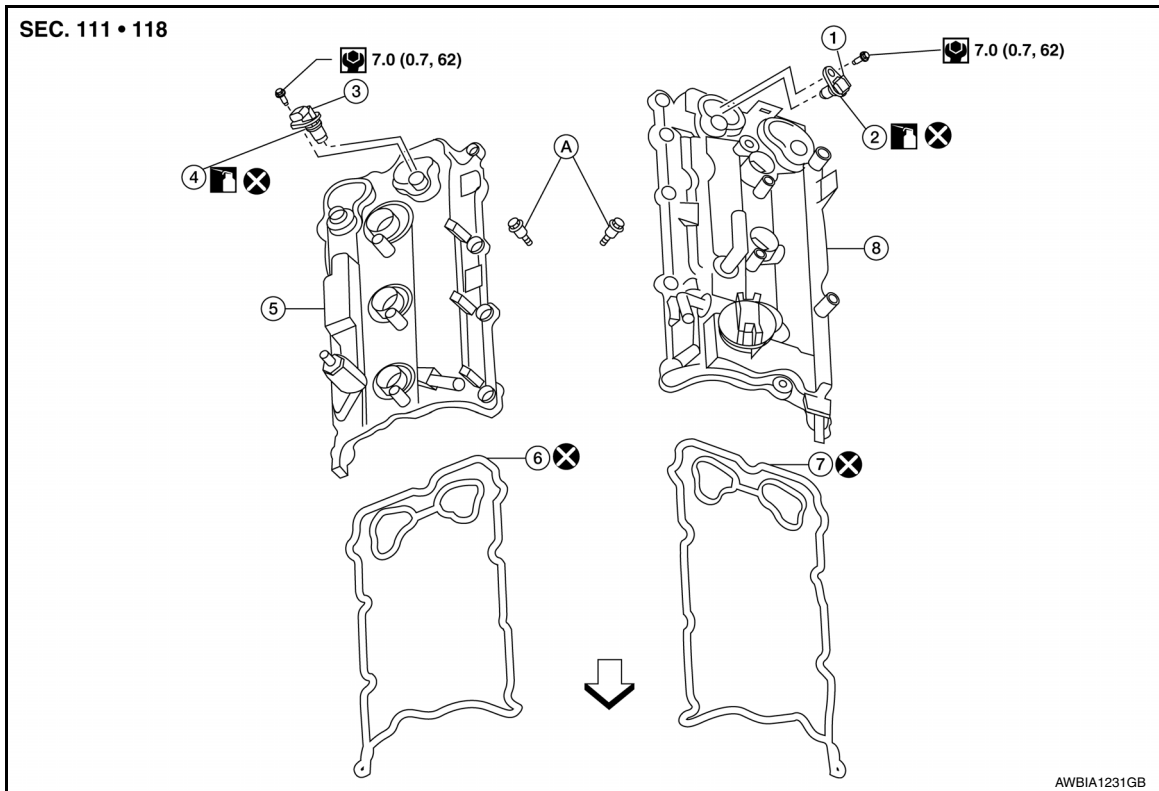

- | | | |
|----------------------------------|----------------------|----------------------------------|
| 1. Camshaft position sensor (LH) | 2. O-ring | 3. Camshaft position sensor (RH) |
| 4. O-ring | 5. Rocker cover (RH) | 6. Rocker cover gasket (RH) |
| 7. Rocker cover gasket (LH) | 8. Rocker cover (LH) | A. Follow installation procedure |

← Engine front

Removal and Installation (LH)

INFOID:000000011148388

REMOVAL

1. Remove the engine room cover. Refer to [EM-23. "Removal and Installation"](#).
2. Remove blow by hose from rocker cover.
3. Remove camshaft position sensor.

CAUTION:

- Handle carefully to avoid dropping and shocks.
- Do not disassemble.
- Do not allow metal powder to adhere to magnetic part at sensor tip (A).
- Do not place sensor in a location where they are exposed to magnetism.

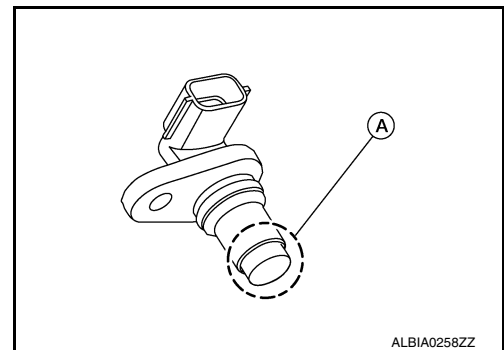

4. Unclip the camshaft position sensor harness connectors.
5. Remove the ignition coils. Refer to [EM-42. "Removal and Installation \(LH\)"](#).

CAUTION:

Do not shock ignition coils.

ROCKER COVER

< REMOVAL AND INSTALLATION >

6. Remove (LH) rocker cover bolts from cylinder head in the reverse order shown.

← : Engine front

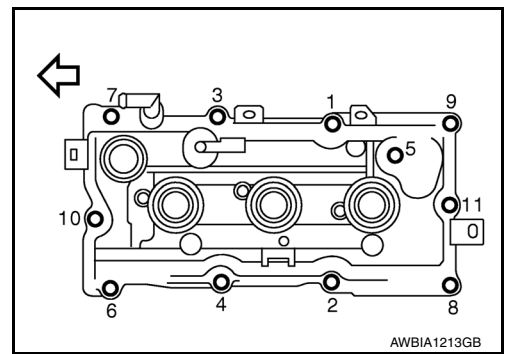

7. Remove the rocker cover and gasket.

INSTALLATION

Installation is in the reverse order of removal.

CAUTION:

- Blow by hose clamps should be installed facing upwards.
- Install press fit hoses so that the white mark faces the rib of the connector.
- Apply sealant to the areas on the front corners using a suitable tool.
- Use Genuine Silicone RTV Sealant or equivalent. Refer to [GI-22](#), "[Recommended Chemical Products and Sealants](#)".

CAUTION:

- Installation should be done within 5 minutes after applying liquid gasket.
- Do not fill the engine with engine oil for at least 30 minutes after the components are installed to allow the sealant to cure.

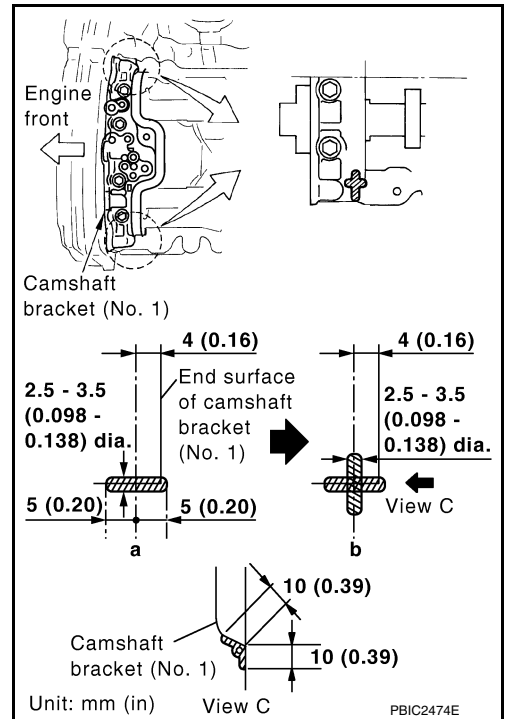

- Tighten the rocker cover bolts to specification in two steps in order shown.

← : Engine front

Rocker cover bolts

Step 1 : 1.96 N·m (0.20 kg-m, 17 in-lb)

Step 2 : 8.33 N·m (0.85 kg-m, 74 in-lb)

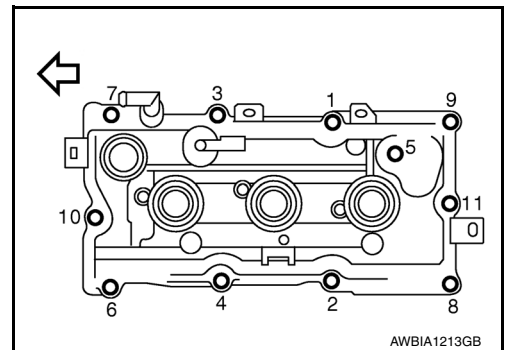

Removal and Installation (RH)

INFOID:000000011148389

REMOVAL

ROCKER COVER

< REMOVAL AND INSTALLATION >

1. Remove the engine room cover. Refer to [EM-23. "Removal and Installation"](#).
2. Remove the front air duct and air duct hose and resonator assembly. Refer to [EM-24. "Removal and Installation"](#).
3. Remove the intake manifold collector. Refer to [EM-29. "Removal and Installation"](#).
4. Remove camshaft position sensors.

CAUTION:

- Handle carefully to avoid dropping and shocks.
- Do not disassemble.
- Do not allow metal powder to adhere to magnetic part at sensor tip (A).
- Do not place sensors in a location where they are exposed to magnetism.

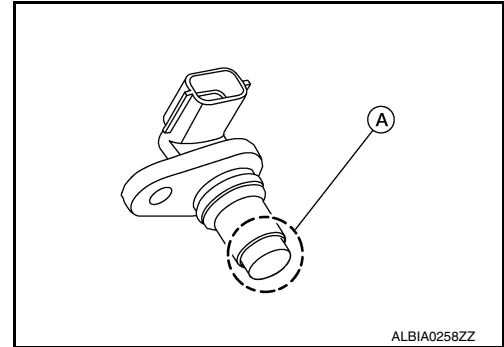

5. Disconnect the breather hose from the rocker cover.
6. Disconnect the ignition coil harness connectors.
7. Remove ignition coils. Refer to [EM-42. "Removal and Installation \(RH\)"](#).

CAUTION:

Do not shock ignition coils.

8. Remove (RH) rocker cover bolts from cylinder head in the reverse order shown.

← : Engine front

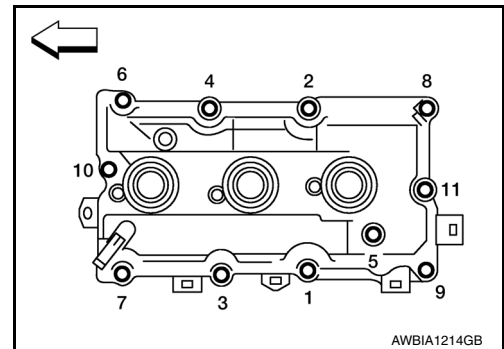

9. Remove the rocker cover and gasket.

INSTALLATION

Installation is in the reverse order of removal.

CAUTION:

- Blow by hose clamps should be installed facing upwards.
- Install press fit hoses so that the white mark faces the rib of the connector.

ROCKER COVER

< REMOVAL AND INSTALLATION >

- Apply sealant to the areas on the front corners using a suitable tool.
- Use Genuine Silicone RTV Sealant or equivalent. Refer to [GI-22, "Recommended Chemical Products and Sealants"](#).

CAUTION:

- Installation should be done within 5 minutes after applying liquid gasket.
- Do not fill the engine with engine oil for at least 30 minutes after the components are installed to allow the sealant to cure.

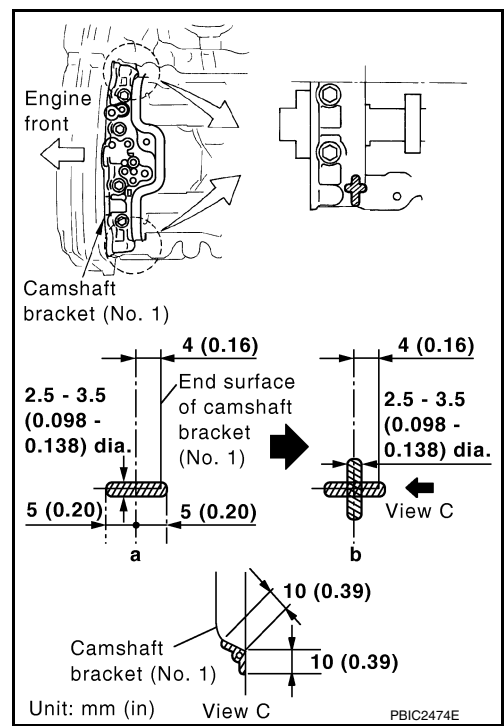

- Tighten the rocker cover bolts in two steps in order as shown.

← : Engine front

Rocker cover bolts

Step 1 : 1.96 N·m (0.20 kg-m, 17 in-lb)

Step 2 : 8.33 N·m (0.85 kg-m, 74 in-lb)

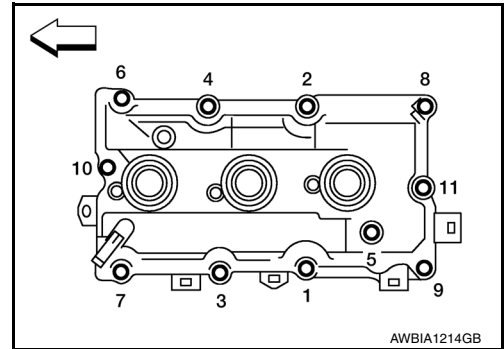

FUEL INJECTOR AND FUEL TUBE

< REMOVAL AND INSTALLATION >

FUEL INJECTOR AND FUEL TUBE

Exploded View

INFOID:000000011148390

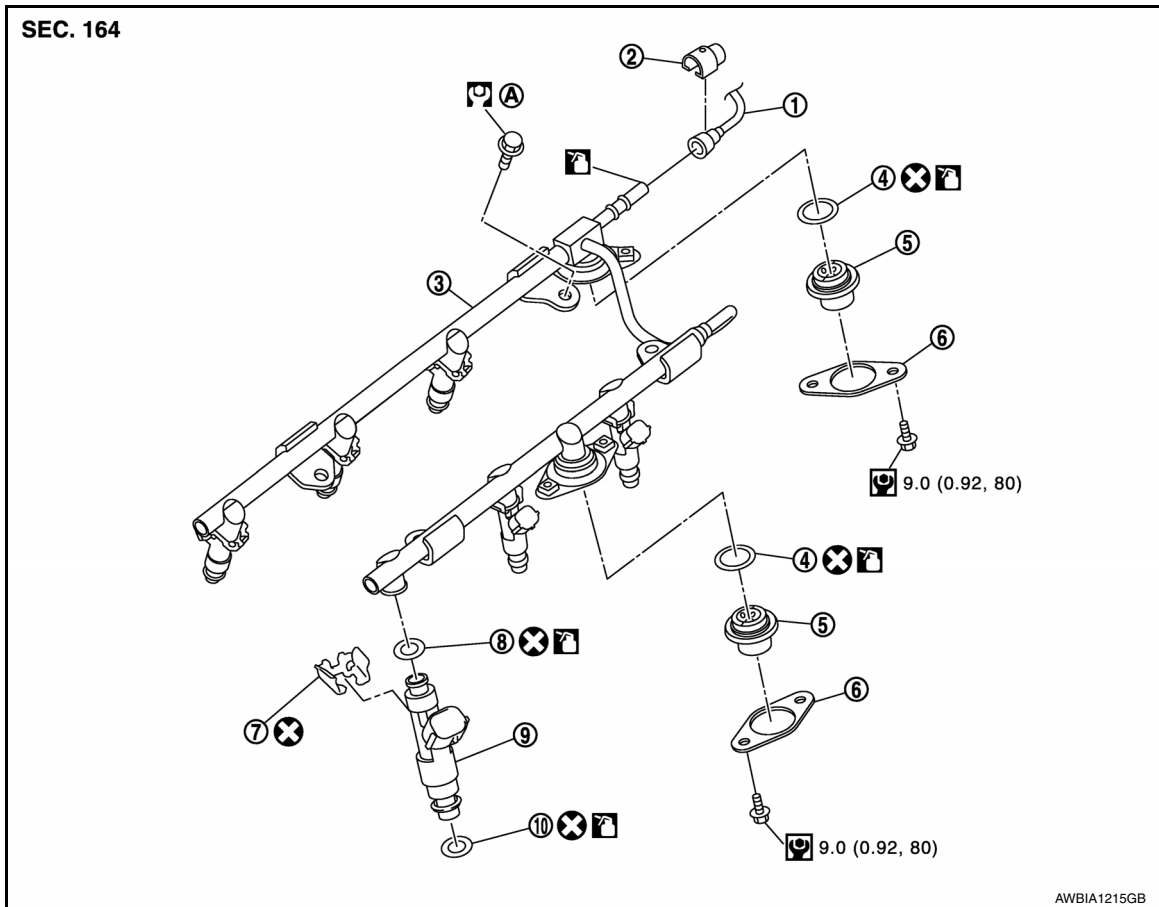

- | | | |
|--------------------|--------------------------|--------------------|
| 1. Fuel feed hose | 2. Quick connector cap | 3. Fuel tube |
| 4. O-ring | 5. Fuel damper | 6. Fuel damper cap |
| 7. Clip | 8. O-ring (black) | 9. Fuel injector |
| 10. O-ring (green) | A. Refer to installation | |

Removal and Installation

INFOID:000000011148391

REMOVAL

WARNING:

- Put a “CAUTION: FLAMMABLE” sign in the workshop.
- Be sure to work in a well ventilated area and furnish workshop with a CO2 fire extinguisher.
- Do not smoke while servicing fuel system. Keep open flames and sparks away from the work area.
- Do not drain engine coolant when engine is hot to avoid the danger of being scalded.

CAUTION:

Do not remove or disassemble parts unless instructed.

NOTE:

When removing components such as hoses, tubes/lines, etc., cap or plug openings to prevent fluid from spilling.

1. Remove engine room cover. Refer to [EM-23, "Removal and Installation"](#).
2. Release the fuel pressure. Refer to [EC-168, "Work Procedure"](#).
3. Disconnect the battery negative terminal. Refer to [PG-95, "Exploded View"](#).
4. Remove intake manifold collector. Refer to [EM-26, "Removal and Installation"](#).

FUEL INJECTOR AND FUEL TUBE

< REMOVAL AND INSTALLATION >

5. When separating fuel feed hose and fuel tube connection, disconnect quick connector using Tool as follows:
 - a. Remove quick connector cap from quick connector.
 - b. Disconnect quick connector from fuel tube as follows:

CAUTION:

Disconnect quick connector by using the Tool, not by prying out retainer tabs.

- i. With the sleeve side of Tool facing toward the quick connector, install the Tool onto fuel tube.
- ii. Insert the Tool (A) into quick connector (2) until sleeve (B) contacts and goes no further. Hold Tool in that position.

(C) : Insert and retain

Tool number (A) : 16441 6N210 (J-45488)

CAUTION:

Inserting Tool with excess force will not disconnect quick connector. Hold quick connector release where it contacts and goes no further.

- iii. Draw and pull out quick connector straight from fuel tube (1).

CAUTION:

- Pull quick connector (E) holding position (D) as shown.
- Do not pull with lateral force applied. O-ring inside quick connector may be damaged.
- Prepare container and cloth beforehand as fuel will leak out.
- Avoid fire and sparks.
- Keep parts away from heat source. Be especially careful when welding is performed around them.
- Do not expose parts to battery electrolyte or other acids.
- Do not bend or twist connection between quick connector and fuel feed hose (with damper) during installation/removal.
- To keep the connecting portion clean and to avoid damage and foreign materials, cover them completely with plastic bags (A) or something similar.

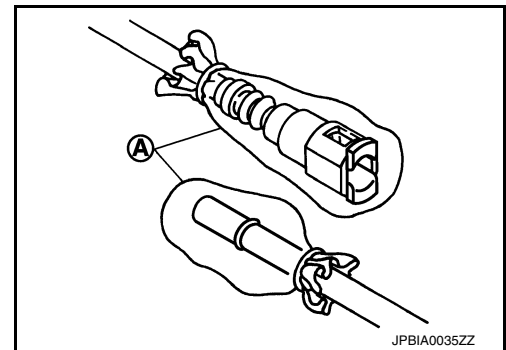
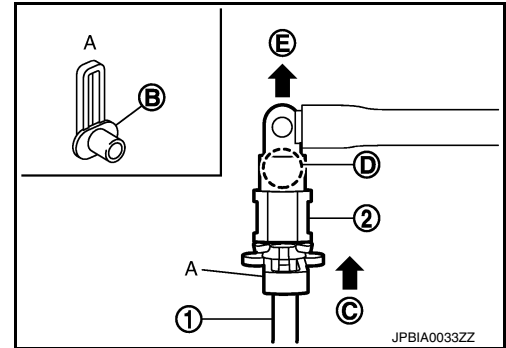

6. Disconnect harness connector from fuel injector.
7. Loosen bolts in reverse order as shown, and remove fuel tube and fuel injector assembly.

← : Engine front

CAUTION:

Do not tilt fuel tube or remaining fuel in pipes may flow out from pipes.

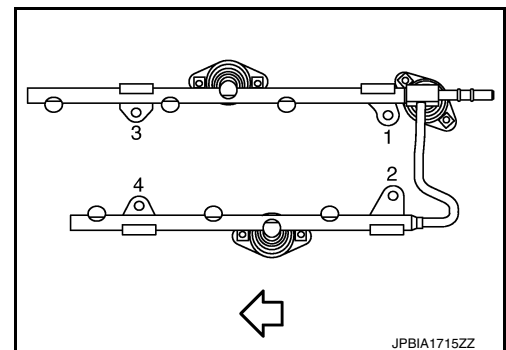

8. Remove fuel injector from fuel tube as follows:

FUEL INJECTOR AND FUEL TUBE

< REMOVAL AND INSTALLATION >

- a. Open and remove clip (1).

- (3) : O-ring (green)
 (4) : O-ring (black)
 (A) : Installed condition
 (B) : Clip mounting groove

- b. Remove fuel injector (2) from fuel tube (5) by pulling straight.

CAUTION:

- Be careful or the remaining fuel in the fuel tube may spill.
- Be careful not to damage injector nozzle during removal.
- Do not bump or drop fuel injector.
- Do not disassemble fuel injector.
- Do not reuse O-rings.

9. Remove fuel damper from fuel tube.

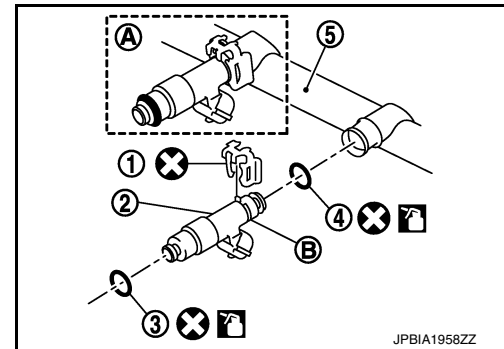

JPBIA1958ZZ

INSTALLATION

1. Install fuel damper as follows:

- a. Install new O-ring (2) to fuel tube (1) as shown. When handling new O-ring, be careful of the following caution:

CAUTION:

- Do not reuse O-rings.
- Handle O-ring with bare hands. Do not wear gloves.
- Lubricate O-ring with new engine oil.
- Do not clean O-ring with solvent.
- Check that O-ring and its mating part are free of foreign material.
- When installing O-ring, be careful not to scratch, nick or damage it. Also be careful not to twist or stretch O-ring.
- Insert new O-ring straight into fuel tube. Be sure O-ring is centered and not twisted.

- b. Install spacer (3) to fuel damper (4).

- c. Insert fuel damper straight into fuel tube.

CAUTION:

- Insert fuel damper until (B) is touching (A) of fuel tube.
- Insert straight, checking that the axis is lined up.
- Do not pressure-fit with excessive force.

Reference value : 130 N (13.3 kg, 29.2 lb)

- d. Tighten bolts evenly in turn.

- After tightening bolts, check that there is no gap between fuel damper cap (5) and fuel tube.

2. Install new O-rings to fuel injector paying attention to the following.

CAUTION:

- Do not reuse O-rings.
- Upper and lower O-ring are different. Be careful to install them in the correct location.
- Handle O-ring with bare hands. Do not wear gloves.
- Lubricate O-ring with new engine oil.
- Do not clean O-ring with solvent.
- Check that O-ring and its mating part are free of foreign material.
- When installing O-ring, be careful not to scratch or nick it. Also be careful not to twist or stretch O-ring.
- Insert O-ring straight into fuel injector. Be sure that the O-ring is centered and not twisted.

3. Install fuel injector to fuel tube as follows:

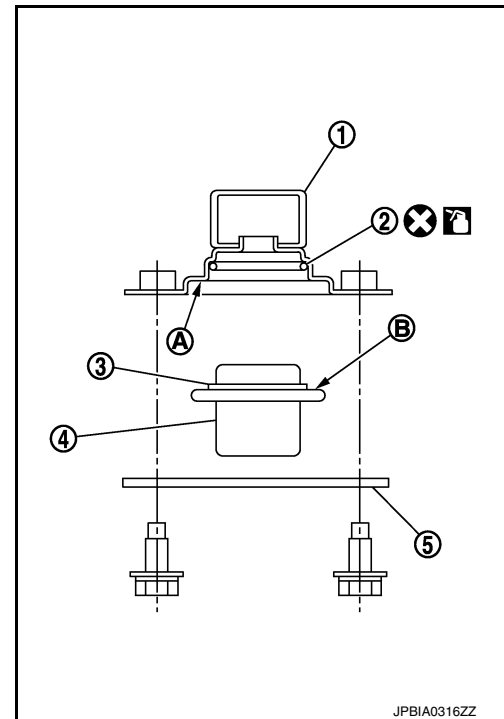

JPBIA0316ZZ

FUEL INJECTOR AND FUEL TUBE

< REMOVAL AND INSTALLATION >

a. Insert clip (3) into clip groove (F) on fuel injector (5).

(2) : O-ring (black)

(4) : O-ring (green)

- Insert clip so that protrusion (E) of fuel injector matches cutout (C) of clip.

CAUTION:

- Do not reuse clip. Replace it with new one.
- Be careful to keep clip from interfering with O-ring. If interference occurs, replace O-ring.
- Do not reuse O-rings.

b. Insert fuel injector into fuel tube (1) with clip attached.

- Insert it while matching it to the axial center.
- Insert fuel injector so that protrusion (A) of fuel tube matches cutout (B) of clip.
- Check that fuel tube flange (G) is securely fixed in flange groove (D) on clip.

CAUTION:

Do not pressure-fit with excessive force.

Reference value : 147 N (15.0 kg, 33.0 lb)

c. Check that installation is complete by checking that fuel injector does not rotate or come off.

- Check that protrusions of fuel injectors and fuel tubes are aligned with cutouts of clips after installation.

4. Install fuel tube and fuel injector assembly to intake manifold.

CAUTION:

Be careful not to let tip of injector nozzle come in contact with other parts.

- Tighten bolts in two steps in numerical order as shown.

↶ : Engine front

1st step : 10.1 N·m (1.0 kg-m, 7 ft-lb)

2nd step : 22.0 N·m (2.2 kg-m, 16 ft-lb)

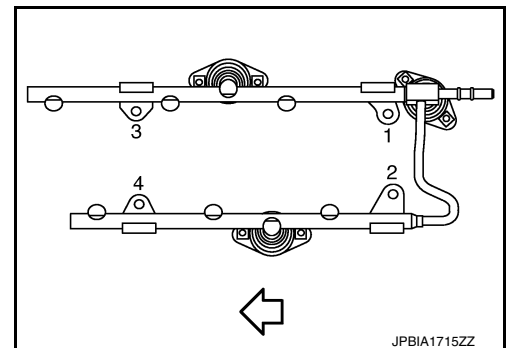
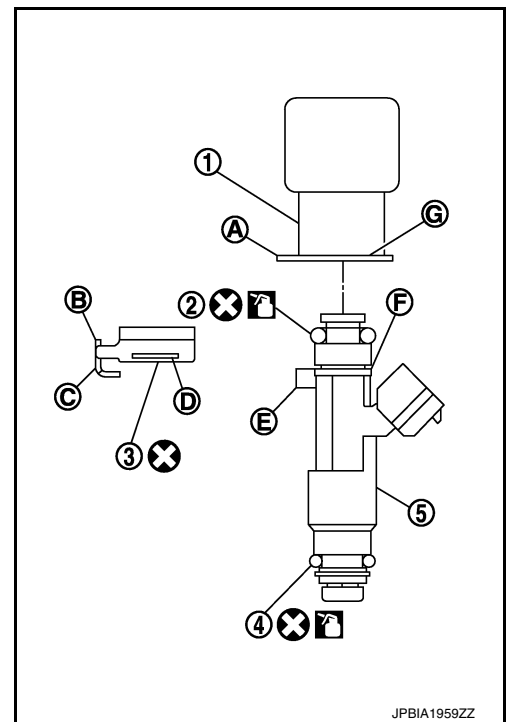

5. Connect fuel injector harness connectors.

6. Install intake manifold collector. Refer to [EM-26, "Removal and Installation"](#).

7. Connect quick connector between fuel feed hose and fuel tube connection with the following procedure:

a. Check no foreign substances are on the fuel tube or quick connector and that they are not damaged.

b. Apply a light coating of new engine oil around fuel tube from tip end to spool end.

c. Align center to insert quick connector straightly into fuel tube.

- Insert quick connector (1) to fuel tube until top spool (2) is completely inside quick connector, and 2nd level spool (3) exposes right below quick connector.

(B) : Installed condition

↶ : Upright insertion

CAUTION:

- Hold (A) position as shown when inserting fuel tube into quick connector.
- Carefully align center to avoid inclined insertion to prevent damage to O-ring inside quick connector.

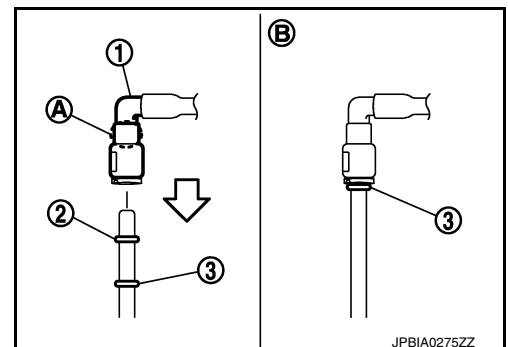

FUEL INJECTOR AND FUEL TUBE

< REMOVAL AND INSTALLATION >

- **Insert until you hear a “click” sound and actually feel the engagement.**
 - **To avoid misidentification of engagement with a similar sound, be sure to perform the next step.**
- d. Pull quick connector by hand holding position. Check it is completely engaged (connected) so that it does not come out from fuel tube.
 - e. Install quick connector cap (3) to quick connector.

- (1) : Fuel feed hose
(2) : Fuel tube
(B) : Upper view

- Install quick connector cap with arrow (A) on surface facing in direction of quick connector (fuel feed hose side).

CAUTION:

If quick connector cap cannot be installed smoothly, quick connector may have not been installed correctly. Check connection again.

- f. Secure fuel feed hose to clamp of quick connector cap.
- g. Installation of the remaining components is in the reverse order of removal.

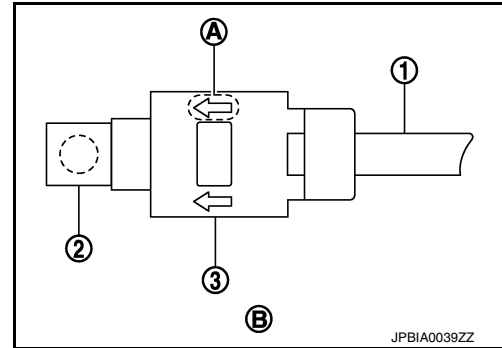

Inspection

INFOID:000000011148392

INSPECTION AFTER INSTALLATION

Check For Fuel Leaks

1. Turn ignition switch “ON” with the engine stopped. With fuel pressure applied to fuel piping, check for fuel leaks at connection points. Repair as necessary.

NOTE:

Use mirrors for checking at points out of clear sight.

2. Start the engine. With engine speed increased, check again for fuel leaks at connection points. Repair as necessary.

WARNING:

Do not touch the engine immediately after stopped, as the engine becomes extremely hot.

NOTE:

Use mirrors for checking on connections out of the direct line of sight.

- Perform procedures for “Throttle Valve Closed Position Learning” after finishing repairs. Refer to [EC-159, "Work Procedure"](#).
- If electric throttle control actuator is replaced, perform procedures for “Idle Air Volume Learning” after finishing repairs. Refer to [EC-160, "Work Procedure"](#).

VALVE TIMING CONTROL

< REMOVAL AND INSTALLATION >

VALVE TIMING CONTROL

Exploded View

INFOID:000000011607900

For United States and Canada

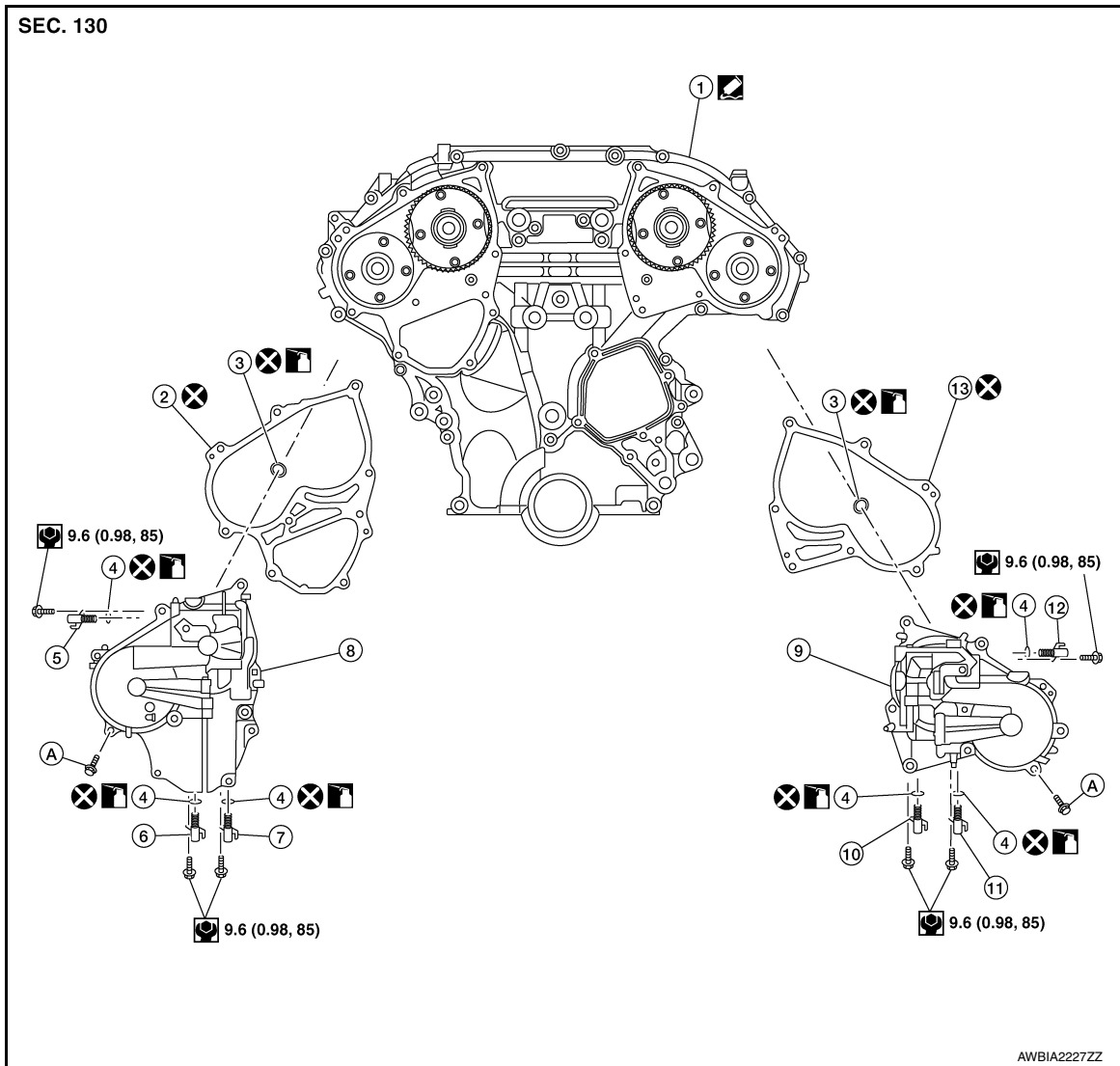

- | | | |
|---|--|---|
| 1. Front timing chain case | 2. Valve timing control cover gas- ket (bank 1) | 3. O-ring |
| 4. O-ring | 5. Intake valve timing intermediate lock control solenoid valve (bank 1) | 6. Exhaust valve timing control sole- noid valve (bank 1) |
| 7. Intake valve timing control sole- noid valve (bank 1) | 8. Valve timing control cover (bank 1) | 9. Valve timing control cover (bank 2) |
| 10. Intake valve timing control sole- noid (bank 2) | 11. Exhaust valve timing control so- lenoid (bank 2) | 12. Intake valve timing intermediate lock control solenoid valve (bank 2) |
| 13. Valve timing control cover gas- ket (bank 2) | A. Refer to INSTALLATION | |

VALVE TIMING CONTROL

< REMOVAL AND INSTALLATION >

For Mexico

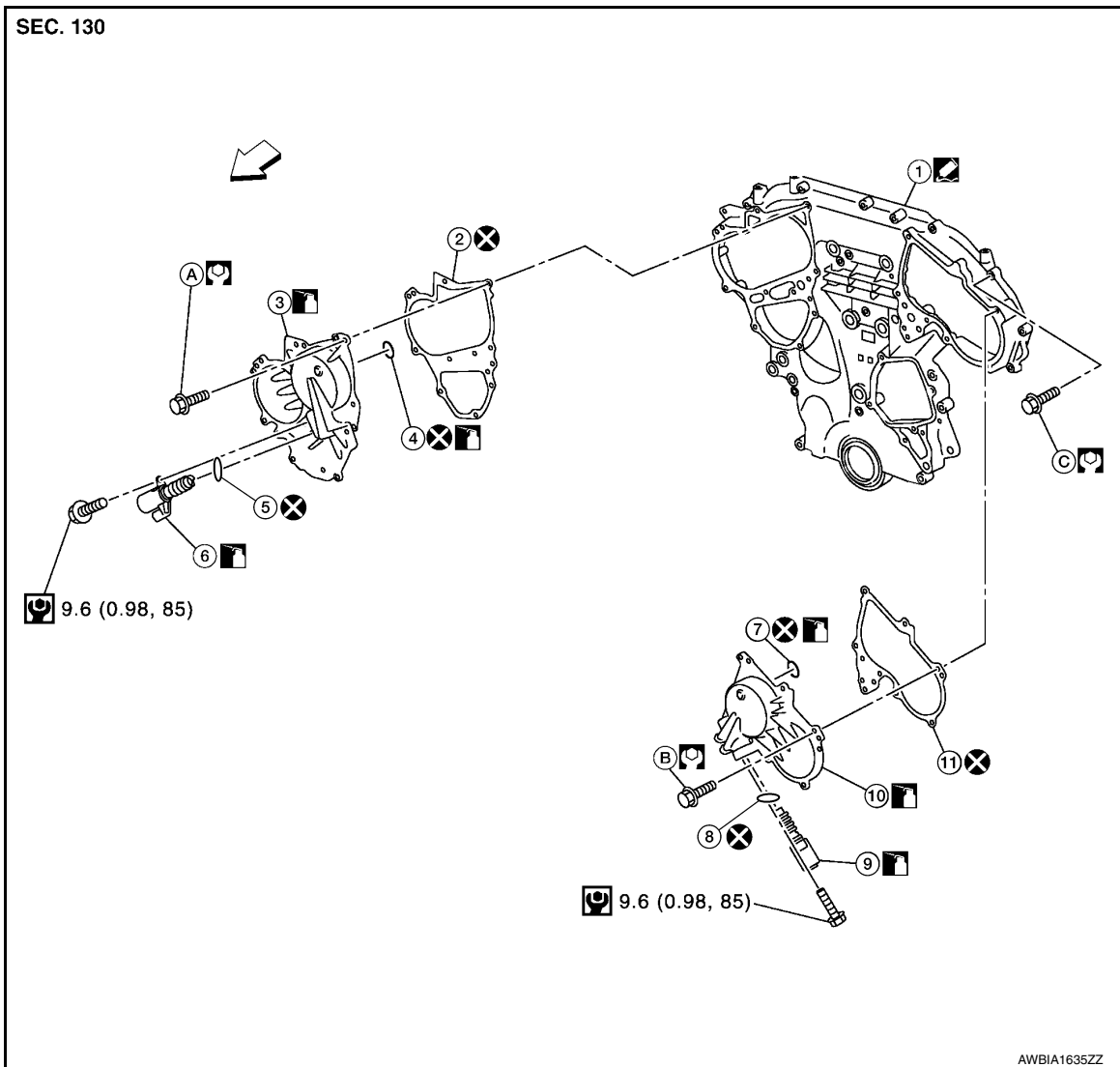

- | | | |
|--|---|--|
| 1. Front timing chain case | 2. Intake valve timing control cover gasket (RH) | 3. Intake valve timing control cover (RH) |
| 4. Intake valve timing control cover O-ring (RH) | 5. Intake valve timing control solenoid valve O-ring (RH) | 6. Intake valve timing control solenoid valve (RH) |
| 7. Intake valve timing control cover O-ring (LH) | 8. Intake valve timing control solenoid valve O-ring (LH) | 9. Intake valve timing control solenoid valve (LH) |
| 10. Intake valve timing control cover (LH) | 11. Intake valve timing control cover gasket (LH) | A. Refer to EM-55 |
| B. Refer to EM-55 | C. Refer to EM-55 | ⇐ Engine front |

Valve Timing Control Cover (bank 1)

INFOID:000000011607901

REMOVAL

1. Disconnect battery negative terminal. Refer to [PG-99. "Exploded View"](#).
2. Remove core support cover. Refer to [EXT-16. "Exploded View"](#).
3. Remove front air duct. Refer to [EM-24. "Exploded View"](#).
4. Remove cowl top. Refer to [EXT-25. "Exploded View"](#).
5. Remove strut tower brace.
6. Remove reservoir tank. Refer to [CO-15. "Exploded View"](#).
7. Remove power steering oil pump (if necessary). Refer to [ST-53. "Removal and Installation"](#).

VALVE TIMING CONTROL

< REMOVAL AND INSTALLATION >

8. Support engine (1) and transaxle (2) using suitable jack (A).

CAUTION:

- Position a suitable jack under the engine and transaxle assembly as shown.
- Do not damage the front exhaust tube or transaxle oil pan with the jack.

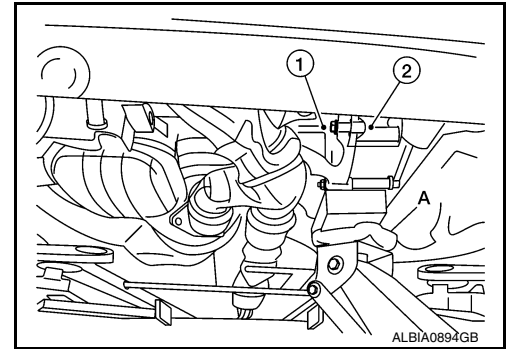

9. Remove upper torque rod, engine mounting insulator (RH), and engine mounting bracket (RH). Refer to [EM-103, "2WD : Exploded View"](#) (2WD) or [EM-107, "4WD : Exploded View"](#) (4WD).
10. Disconnect intake valve timing intermediate lock control solenoid valve (bank 1) harness connector. (For United States and Canada)
11. Disconnect exhaust valve timing control solenoid valve (bank 1) harness connector. (For United States and Canada)
12. Disconnect intake valve timing control solenoid valve (bank 1) harness connector.
13. Remove intake valve timing intermediate lock control solenoid valve (bank 1) and exhaust valve timing control solenoid valve (bank 1) from valve timing control cover (bank 1). (For United States and Canada)

CAUTION:

Do not reuse O-rings.

14. Remove intake valve timing control solenoid valve (bank 1) from valve timing control cover (bank 1).

CAUTION:

Do not reuse O-rings.

INSTALLATION

Installation of components is in the reverse order of removal.

CAUTION:

- Do not reuse O-rings.
- Lubricate O-rings with clean engine oil prior to installation.

Valve Timing Control Cover (bank 2)

INFOID:000000011607902

REMOVAL

1. Remove power steering oil pump. Refer to [ST-53, "Removal and Installation"](#).
2. Disconnect intake valve timing intermediate lock control solenoid valve (bank 2) harness connector. (For United States and Canada)
3. Disconnect exhaust valve timing control solenoid valve (bank 2) harness connector. (For United States and Canada)
4. Disconnect intake valve timing control solenoid valve (bank 2) harness connector.
5. Remove intake valve timing intermediate lock control solenoid valve (bank 2) and exhaust valve timing control solenoid valve (bank 2) from valve timing control cover (bank 2). (For United States and Canada)

CAUTION:

Do not reuse O-rings.

6. Remove intake valve timing control solenoid valve (bank 2) from valve timing control cover (bank 2).

CAUTION:

Do not reuse O-rings.

INSTALLATION

Installation components is in the reverse order of removal.

CAUTION:

- Do not reuse O-rings.
- Lubricate O-rings with clean engine oil prior to installation.

FRONT TIMING CHAIN CASE

< REMOVAL AND INSTALLATION >

FRONT TIMING CHAIN CASE

Exploded View

INFOID:000000011148396

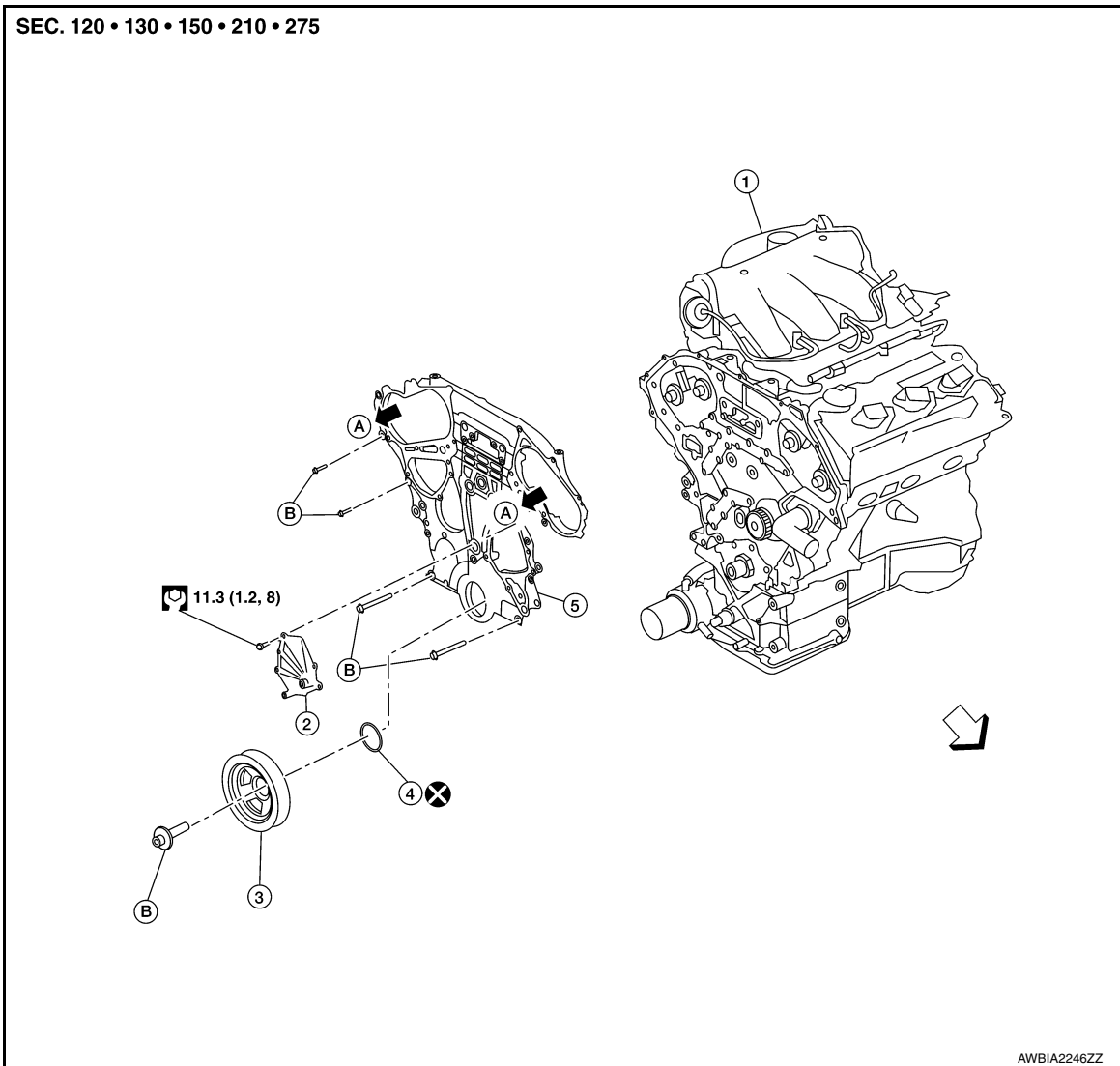

- | | | |
|--------------------------|----------------------------|---|
| 1. Engine assembly | 2. Water pump cover | 3. Crankshaft pulley |
| 4. Front oil seal | 5. Front timing chain case | A. To Valve timing control cover (bank 1/ bank 2). Refer to EM-52 |
| B. Refer to INSTALLATION | ⇐ Front | |

Removal and Installation

INFOID:000000011148397

NOTE:

- This section describes the procedure for removal/installation of the front timing chain case in vehicle and without removing the oil pan (upper). Remove the engine prior to following this procedure if the engine is to be removed to facilitate other repairs.
- To remove the rear timing chain case, remove the engine from the vehicle. Refer to [EM-71, "Removal and Installation"](#)
- Refer to [EM-63, "Exploded View"](#) for component parts location.
- When removing components such as hoses, tubes/lines, etc., cap or plug openings to prevent fluid from spilling.

REMOVAL

FRONT TIMING CHAIN CASE

< REMOVAL AND INSTALLATION >

1. Remove engine room cover. Refer to [EM-23, "Removal and Installation"](#).
2. Remove cowl top and cowl top lower panel extension. Refer to [EXT-25, "Removal and Installation"](#).
3. Drain the engine oil. Refer to [LU-9, "Changing Engine Oil"](#).
4. Disconnect coolant reservoir hose from the radiator and remove coolant reservoir.
5. Remove the radiator. Refer to [CO-15, "Removal and Installation"](#).
6. Remove the radiator shroud and cooling fan assembly. Refer to [CO-17, "Removal and Installation"](#).
7. Remove battery tray and bracket. Refer to [PG-97, "Removal and Installation"](#).
8. Remove the electric power steering oil pump motor assembly and bracket. Refer to [ST-53, "Removal and Installation"](#).
9. Remove rocker covers. Refer to [EM-43, "Exploded View"](#).
10. If removing the timing chains, obtain compression TDC of No. 1 cylinder as follows:
 - a. Rotate crankshaft pulley clockwise to align timing mark (grooved line without color) with timing indicator (A).

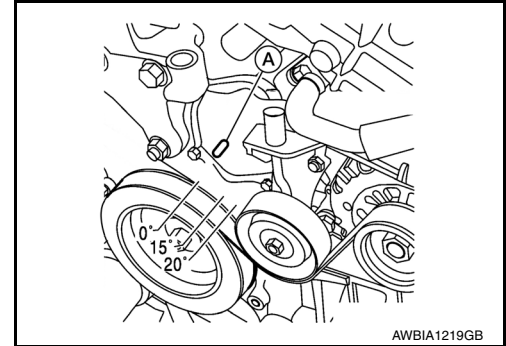

- b. Check that intake and exhaust camshaft lobes on No. 1 cylinder (RH of engine) are located as shown.
 - If not, turn the crankshaft one revolution (360°) and align as shown.

NOTE:

The graphic shows the RH bank of the engine. The camshaft lobes on the LH bank are clocked differently.

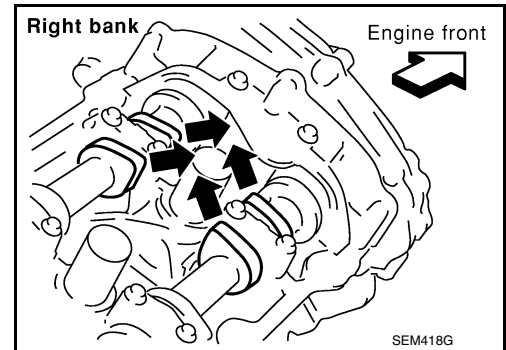

11. Remove the water pump. Refer to [CO-19, "Removal and Installation"](#).
12. Lock the drive plate using Tool.

Tool number : — (J-50288)

CAUTION:

Do not damage the ring gear teeth or the signal plate teeth behind the ring gear when setting the Tool.

13. Remove the crankshaft pulley as follows:
 - a. Loosen crankshaft pulley bolt and locate bolt seating surface at 10 mm (0.39 in) from its original position.
 - b. Position a suitable tool at recess hole of crankshaft pulley to remove crankshaft pulley.

CAUTION:

Do not use a puller claw on the outer diameter of the crankshaft pulley.

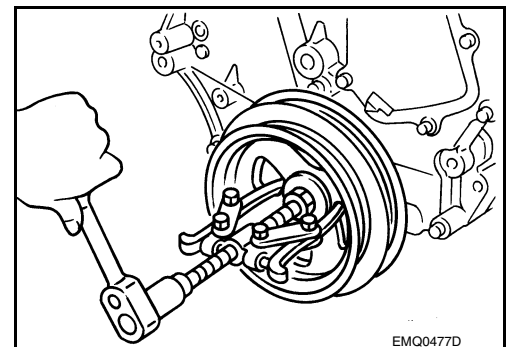

14. Remove the generator and generator bracket. Refer to [CHG-29, "Removal and Installation"](#).

FRONT TIMING CHAIN CASE

< REMOVAL AND INSTALLATION >

15. Support the engine with suitable tool and remove the engine mounting insulator (RH), engine mounting insulator (Front) and engine mounting insulator (Rear). Refer to [EM-103, "2WD : Exploded View"](#) (2WD) or [EM-107, "4WD : Exploded View"](#) (4WD).
16. Disconnect the oil pressure switch harness connector.
17. Remove the lower oil pan. Refer to [EM-36, "Removal and Installation \(Lower Oil Pan\)"](#).
18. Remove engine mounting bracket (front). Refer to [EM-103, "2WD : Exploded View"](#) (2WD) or [EM-107, "4WD : Exploded View"](#) (4WD).
19. Disconnect the intake valve timing control solenoid valve harness connectors (bank1/bank2).
20. Disconnect the intake timing intermediate lock control solenoid valve harness connectors and the exhaust valve timing control solenoid valve harness connectors (bank1/bank2).
21. Remove the intake valve timing control cover [(bank1) A] and intake valve timing control cover [(bank 2) B].

- For USA and Canada
Loosen the intake valve timing control cover RH and intake valve timing control cover LH bolts in the reverse order as shown.

CAUTION:

The shaft in the intake valve timing control cover is inserted into the center hole of the intake camshaft sprocket. Remove the intake valve timing control cover by pulling straight out until the intake valve timing control cover disengages from the camshaft sprocket.

- (A) : Bank 1 (RH)
- (B) : Bank 2 (LH)
- (C) : Dowel pin hole

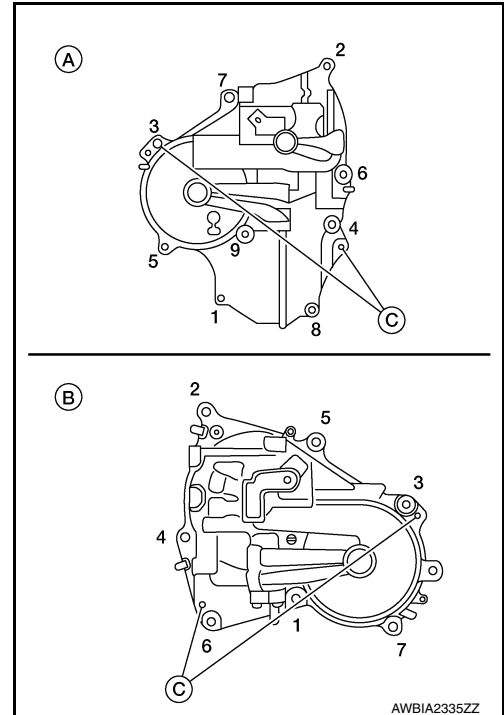

- For Mexico
Loosen the intake valve timing control cover [(bank1) A] and intake valve timing control cover [(bank 2) B] bolts in the reverse order as shown.

CAUTION:

The shaft in the intake valve timing control cover is inserted into the center hole of the intake camshaft sprocket. Remove the intake valve timing control cover by pulling straight out until the intake valve timing control cover disengages from the camshaft sprocket.

- (A) : Bank 1 (RH)
- (B) : Bank 2 (LH)
- (C) : Dowel pin hole

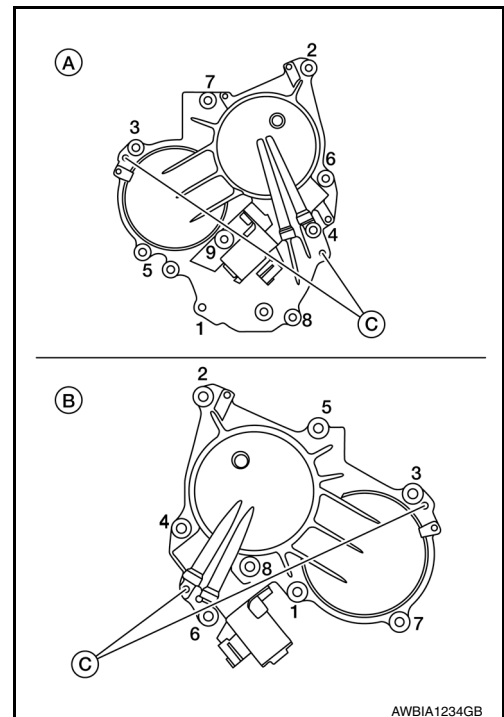

FRONT TIMING CHAIN CASE

< REMOVAL AND INSTALLATION >

22. Remove the front timing chain case.

a. Loosen the front timing chain case bolts in the reverse order shown.

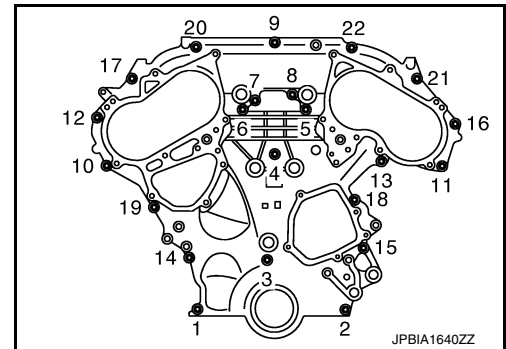

b. Insert the appropriate size tool into the notch (A) at the top of the front timing chain case as shown.

c. Pry off the case by moving the suitable tool (B) as shown.

• Cut liquid gasket for removal using Tool.

CAUTION:

• Do not use a screwdriver or similar tool.

• After removal, handle carefully so it does not bend or warp under a load.

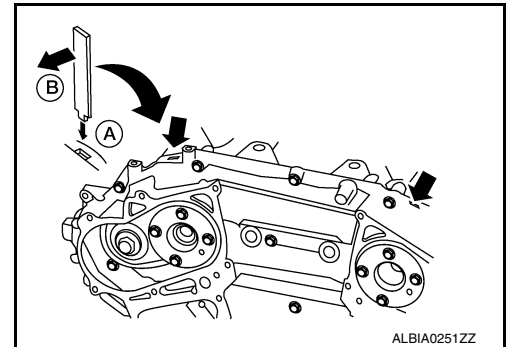

23. Remove O-rings (1) from rear timing chain case.

(A) : Bank 1 (RH)

(B) : Bank 2 (LH)

CAUTION:

Use new O-rings for installation.

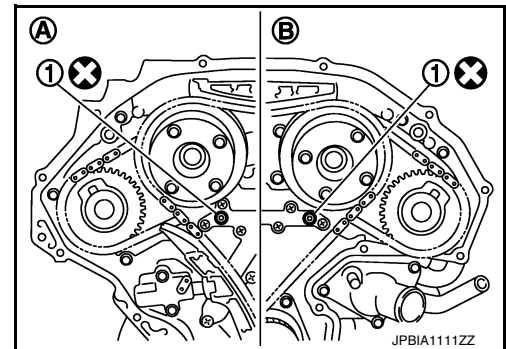

24. Remove the front oil seal from the front timing chain case using a suitable tool.

CAUTION:

Do not damage the front cover.

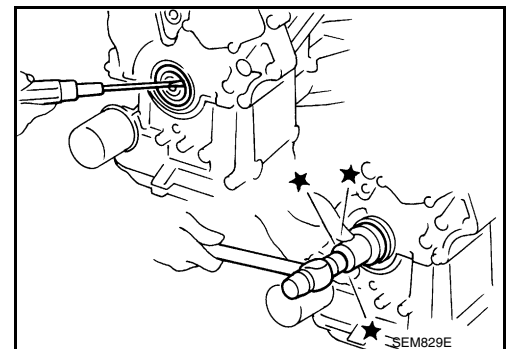

25. Remove all old liquid gasket from all the bolt holes and bolts.

CAUTION:

Do not damage the threads or mating surfaces.

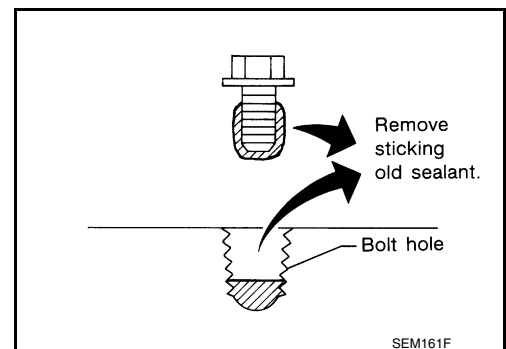

FRONT TIMING CHAIN CASE

< REMOVAL AND INSTALLATION >

26. Use a scraper to remove all of the old liquid gasket from the front timing chain case and opposite mating surfaces.

CAUTION:

Do not damage the mating surfaces.

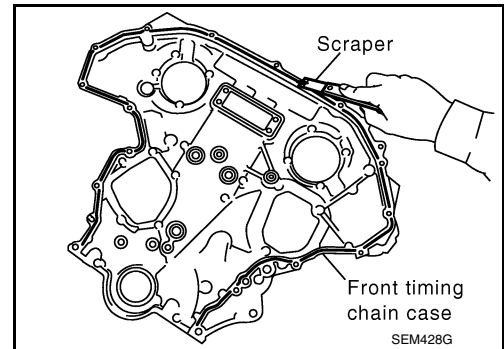

INSTALLATION

1. Install dowel pins (right and left) into front timing chain case up to a point close to taper in order to shorten protrusion length.

NOTE:

Be sure to place the dowel pins in original hole locations in the front timing chain case.

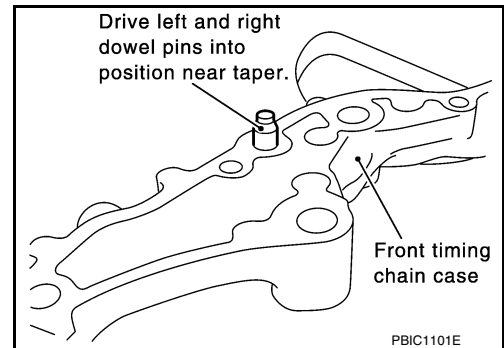

2. Install the new front oil seal on the front timing chain case. Apply new engine oil to the oil seal edges.

CAUTION:

Do not reuse the front oil seal.

NOTE:

Install it so that each seal lip is oriented as shown.

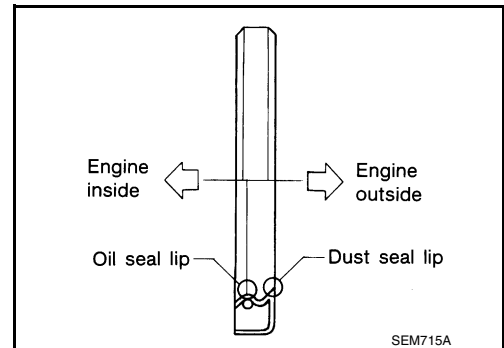

- a. Install the new front oil seal so that it becomes flush with the face of front timing chain case using suitable tool.

CAUTION:

Press fit straight and avoid causing burrs or tilting the oil seal.

NOTE:

Make sure the garter spring is in position and seal lip is not inverted.

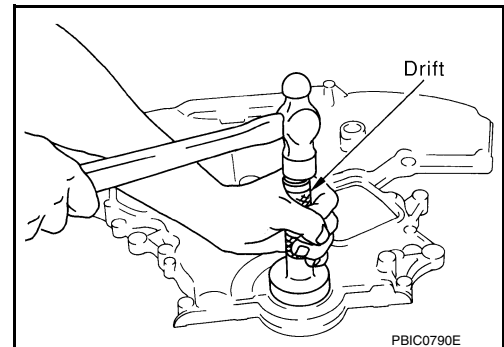

A
EM
C
D
E
F
G
H
I
J
K
L
M
N
O
P

FRONT TIMING CHAIN CASE

< REMOVAL AND INSTALLATION >

3. Install new O-rings (1) on rear timing chain case.

(A) : Bank 1 (RH)

(B) : Bank 2 (LH)

CAUTION:

Do not reuse O-rings.

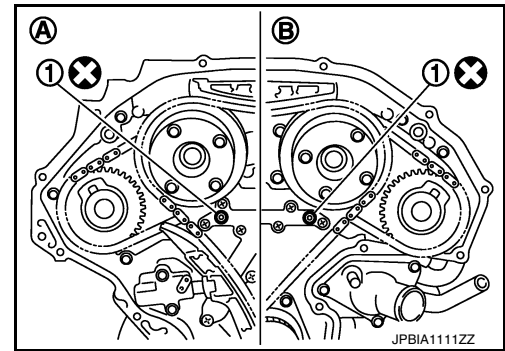

4. Apply liquid gasket to front timing chain case as shown.
- Use Genuine Silicone RTV Sealant or equivalent. Refer to [GI-22. "Recommended Chemical Products and Sealants"](#).
 - Before installation, wipe off the protruding liquid gasket.
 - (C): 2.6 - 3.6 mm (0.102 - 0.142 in) diameter.

CAUTION:

- Installation should be done within 5 minutes after applying liquid gasket.
- Do not fill the engine with engine oil for at least 30 minutes after the components are installed to allow the liquid gasket to cure.

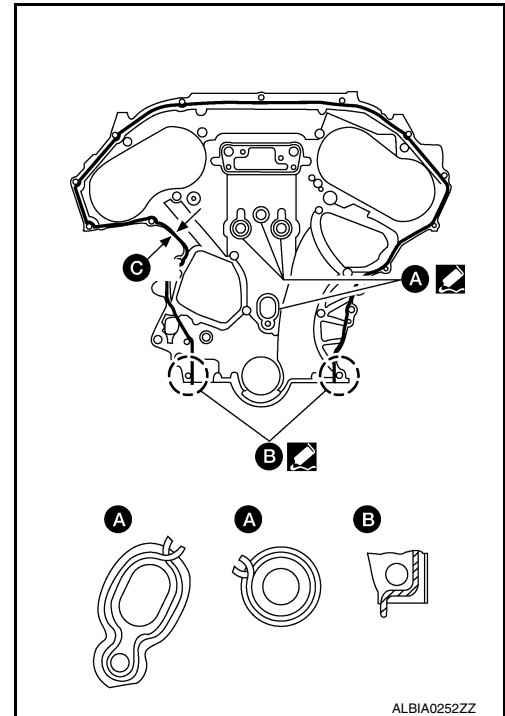

5. Install the front timing chain case by aligning the dowel pin on the rear timing chain case with the dowel pin hole in front timing chain case.
6. Loosely install the front timing chain case bolts.

| Bolt position | Bolt diameter |
|---------------|------------------|
| 1, 2 | : 8 mm (0.31 in) |
| 3 – 22 | : 6 mm (0.24 in) |

7. Tighten the front timing chain case bolts in the order shown.
- Retighten the front timing chain case bolts in the order shown.

| Bolt position | Tightening specification |
|---------------|---------------------------------|
| 1, 2 | : 28.4 N·m (2.9 kg-m, 21 ft-lb) |
| 3 – 22 | : 12.7 N·m (1.3 kg-m, 9 ft-lb) |

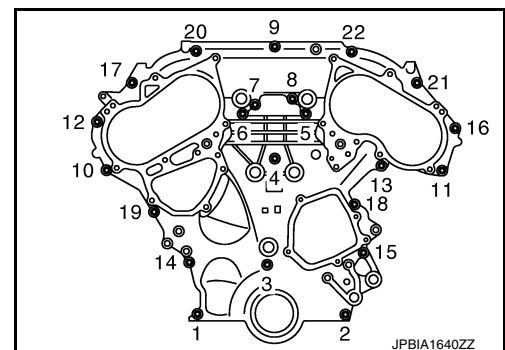

8. Install intake valve timing control cover (bank 1) and intake valve timing control cover (bank 2).
- a. Install new seal rings in shaft grooves.

CAUTION:

- When replacing seal rings, replace all rings with new ones on both intake valve timing control cover RH and intake valve timing control cover LH.
- Do not reuse O-rings.

FRONT TIMING CHAIN CASE

< REMOVAL AND INSTALLATION >

- b. Install intake valve timing control cover (bank 1) and intake valve timing control cover (bank 2) with new gaskets to front timing chain case.

CAUTION:

Ensure the seal ring remains in the shaft groove.

- c. Being careful not to move seal ring from the installation groove, align the dowel pins on the front timing chain case with the holes to install valve timing control covers.
- d. Tighten bolts in the numerical order as shown (For USA and Canada).

Intake valve timing control cover bolts 11.3 N·m (1.2 kg-m, 8 ft-lb)

- (A) : Bank 1 (RH)
- (B) : Bank 2 (LH)
- (C) : Dowel pin hole

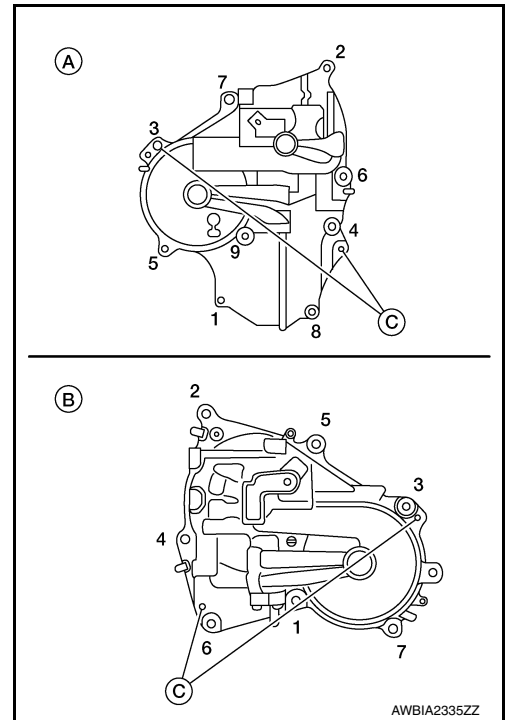

- e. Tighten bolts in the numerical order as shown (For Mexico).

Intake valve timing control cover bolts 11.3 N·m (1.2 kg-m, 8 ft-lb)

- (A) : Bank 1 (RH)
- (B) : Bank 2 (LH)
- (C) : Dowel pin hole

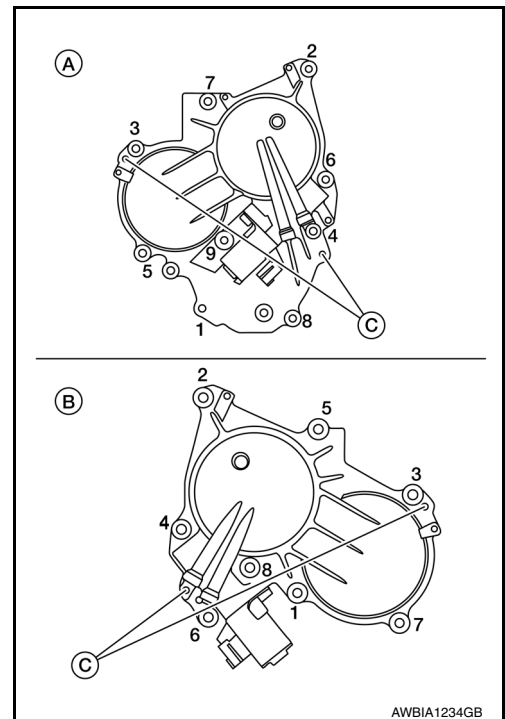

9. Install the water pump. Refer to [CO-19, "Removal and Installation"](#).
10. Install crankshaft pulley and tighten the bolt in two steps.
- Lubricate thread and seat surface of the bolt with new engine oil.
 - For the second step, angle tighten using Tool.

CAUTION:

Do not damage the front oil seal when inserting crankshaft pulley.

A
EM
C
D
E
F
G
H
I
J
K
L
M
N
O
P

FRONT TIMING CHAIN CASE

< REMOVAL AND INSTALLATION >

- Use only brass or plastic hammer if tapping on the crankshaft pulley.
- Do not hammer on pulley grooves.

Step 1 : 44.1 N·m (4.5 kg-m, 33 ft-lb)

Step 2 : 90°(+0°/-6°) clockwise

Tool number : KV10112100 (BT-8653-A)

11. Remove the Tool to unlock the drive plate.

Tool number : — (J-50288)

CAUTION:

Do not damage the ring gear teeth or the signal plate teeth behind the ring gear when removing the Tool.

12. Rotate crankshaft pulley in normal direction (clockwise when viewed from front) to confirm it turns smoothly.
13. Installation of the remaining components is in the reverse order of removal.

INSPECTION AFTER INSTALLATION

- Before starting engine, check oil/fluid levels including engine coolant and engine oil. If less than required quantity, fill to the specified level. Refer to [MA-15, "FOR USA AND CANADA : Fluids and Lubricants"](#) (United States and Canada) or [MA-17, "FOR MEXICO : Fluids and Lubricants"](#) (Mexico).
- Use procedure below to check for fuel leakage.
- Turn ignition switch ON (with engine stopped). With fuel pressure applied to fuel piping, check for fuel leakage at connection points.
- Start engine. With engine speed increased, check again for fuel leakage at connection points.
- Run engine to check for unusual noise and vibration.

NOTE:

If hydraulic pressure inside timing chain tensioner drops after removal and installation, slack in the guide may generate a pounding noise during and just after engine start. However, this is normal. Noise will stop after hydraulic pressure rises.

- Warm up engine thoroughly to make sure there is no leakage of fuel, exhaust gas, or any oils/fluids including engine oil and engine coolant.
- Bleed air from passages in lines and hoses, such as in cooling system.
- After cooling down engine, again check oil/fluid levels including engine oil and engine coolant. Refill to specified level, if necessary.
- Summary of the inspection items:

| Item | | Before starting engine | Engine running | After engine stopped |
|----------------------------------|--------------------|------------------------|----------------|----------------------|
| Engine coolant | | Level | Leakage | Level |
| Engine oil | | Level | Leakage | Level |
| Transmission/ transaxle fluid | A/T and CVT Models | Leakage | Level/Leakage | Leakage |
| | M/T Models | Level/Leakage | Leakage | Level/Leakage |
| Other oils and fluids* | | Level | Leakage | Level |
| Fuel | | Leakage | Leakage | Leakage |
| Exhaust gas | | — | Leakage | — |

*Power steering fluid, brake fluid, etc.

TIMING CHAIN

< REMOVAL AND INSTALLATION >

TIMING CHAIN

Exploded View

INFOID:0000000011148398

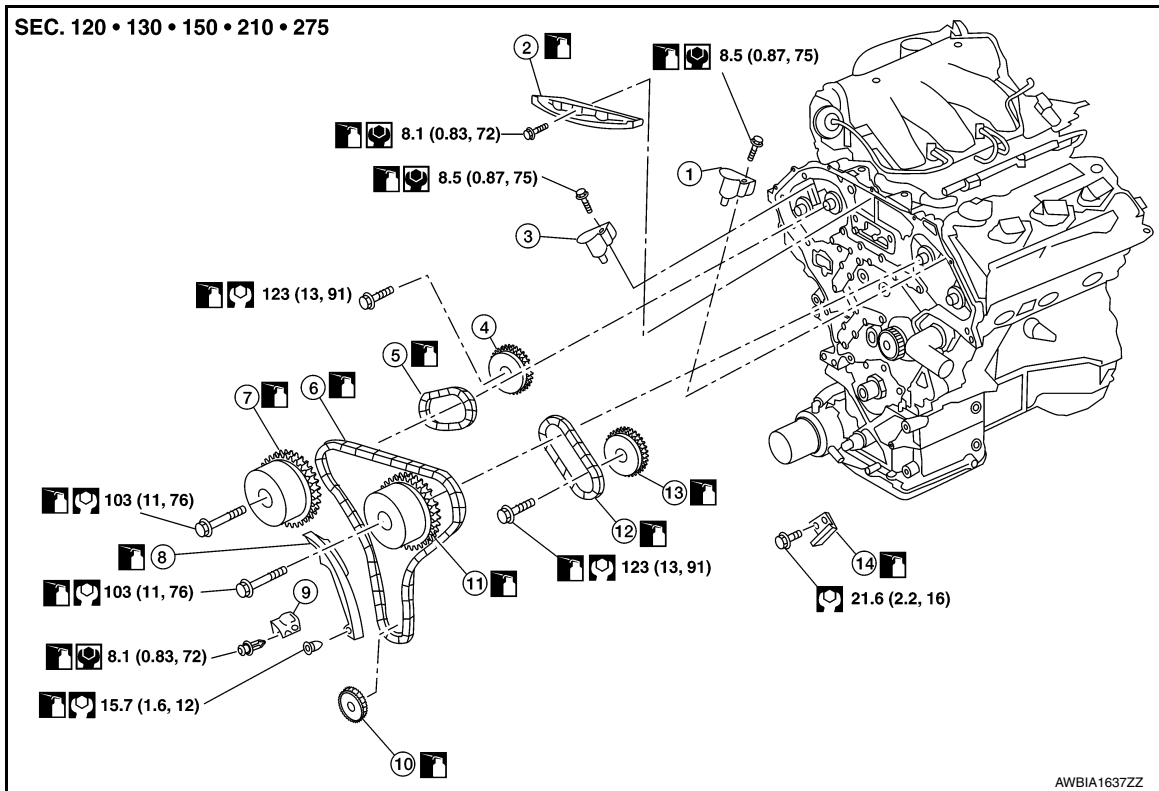

- | | | |
|--|--------------------------------|--|
| 1. Timing chain tensioner (secondary) (LH) | 2. Internal chain guide | 3. Timing chain tensioner (secondary) (RH) |
| 4. Camshaft sprocket RH (EXH) | 5. Timing chain (secondary) | 6. Timing chain (primary) |
| 7. Camshaft sprocket RH (INT) | 8. Slack guide | 9. Timing chain tensioner (primary) |
| 10. Crankshaft sprocket | 11. Camshaft sprocket LH (INT) | 12. Timing chain (secondary) |
| 13. Camshaft sprocket LH (EXH) | 14. Tension guide | |

Removal and Installation

INFOID:0000000011148399

CAUTION:

- After removing timing chains, do not turn the crankshaft and camshaft separately or the valves will strike the pistons.
- When installing camshafts, chain tensioners, oil seals, or other sliding parts, lubricate contacting surfaces with new engine oil.
- Apply new engine oil to bolt threads and seat surfaces when installing camshaft sprockets, camshaft brackets, and crankshaft pulley.

REMOVAL

1. Remove front timing chain case. Refer to [EM-55. "Removal and Installation"](#).
2. Remove the intake manifold collector. Refer to [EM-26. "Removal and Installation"](#).
3. Remove the spark plugs. Refer to [EM-16. "Removal and Installation"](#).
4. Place paint marks on the timing chain and sprockets to indicate the correct position of the components for installation.
5. Disconnect the camshaft position sensor harness connectors.
6. Remove the timing chain tensioner (primary).

TIMING CHAIN

< REMOVAL AND INSTALLATION >

- a. Pull lever down and release plunger stopper tab. Plunger stopper tab can be pushed up to release (coaxial structure with lever).

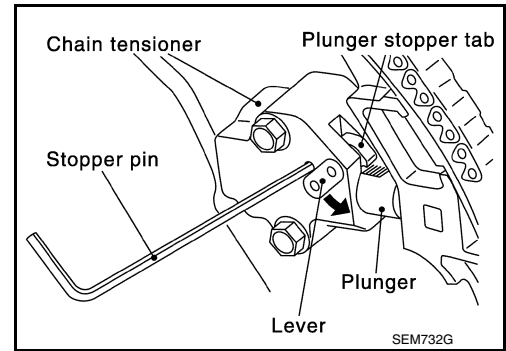

- b. Insert stopper pin into timing chain tensioner (primary) body hole to hold lever, and keep the tab released. An Allen wrench [1.2 mm (0.047 in)] is used for a stopper pin as an example.
- c. Insert plunger into tensioner body by pressing the slack guide.
- d. Keep the slack guide pressed and hold it by pushing the stopper pin through the lever hole and body hole.
- e. Remove the bolts and remove the timing chain tensioner (primary).

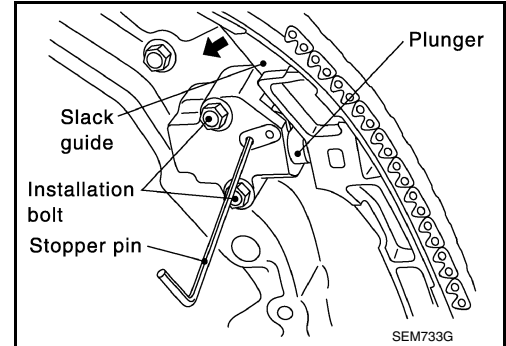

7. Remove internal chain guide, tension guide and slack guide.

NOTE:

Tension guide can be removed after removing timing chain (primary).

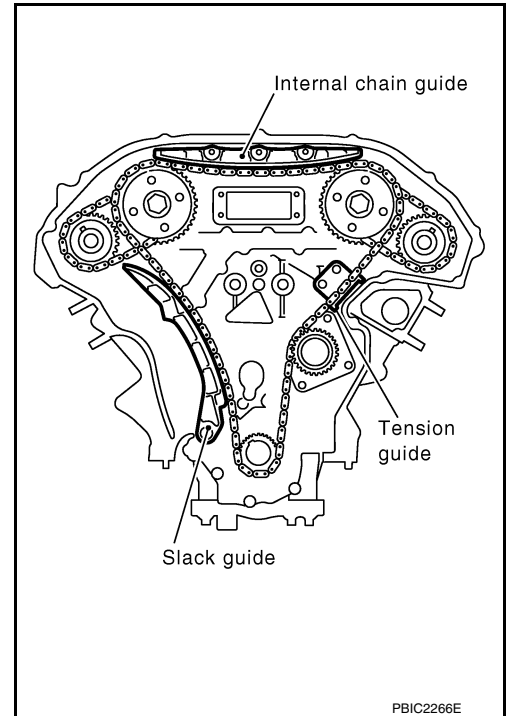

8. Remove timing chain (primary) and crankshaft sprocket.

CAUTION:

After removing timing chains, do not turn the crankshaft and camshaft separately or the valves will strike the pistons.

9. Remove timing chain (secondary) and camshaft sprockets as follows:

TIMING CHAIN

< REMOVAL AND INSTALLATION >

- a. Attach a suitable stopper pin (B) to the bank 1 (A) and bank 2 (C) timing chain tensioners (secondary) (1).

NOTE:

- Use approximately 0.5 mm (0.02 in) diameter hard metal pin as a stopper pin.
- Removal of camshaft bracket (No. 1) is required prior to removing the timing chain tensioner (secondary).

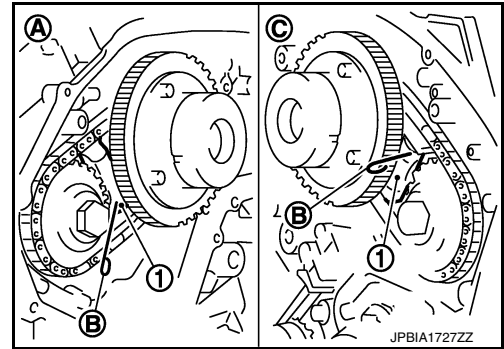

- b. Remove camshaft sprockets (INT and EXH) bolts.
- Secure the hexagonal portion of camshaft using a wrench to loosen bolts.

CAUTION:

Do not loosen bolts using anything other than the camshaft hexagonal portion. Do not apply tension to the timing chain.

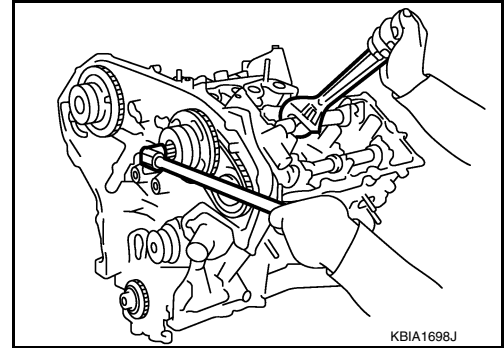

- c. Remove timing chain (secondary) together with camshaft sprockets.
- Turn camshaft slightly to keep the chain tight when removing the timing chain (secondary).
 - Insert 0.5 mm (0.020 in) thick metal or resin plate between timing chain and timing chain tensioner plunger (guide) (E). Remove timing chain (secondary) (2) together with camshaft sprockets with timing chain loose from guide groove.

- (1) : Timing chain tensioner (secondary)
- (A) : Bank 1
- (B) : View B
- (C) : Stopper pin
- (D) : Plate
- (F) : Timing chain tensioner (body)

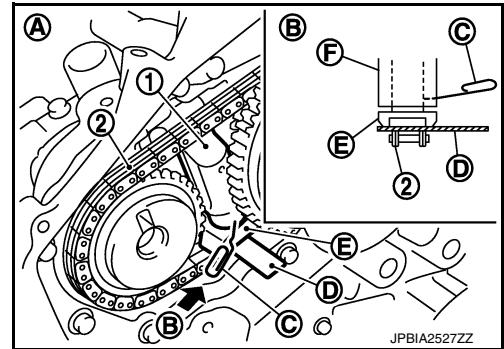

CAUTION:

Be careful of plunger coming off when removing timing chain (secondary). The plunger of timing chain tensioner (secondary) moves during operation, which could cause the stopper pin to fall out.

- Bank 1 shown.

- d. Camshaft sprocket (INT) is two-for-one structure of sprockets for timing chain (primary) and for timing chain (secondary).

CAUTION:

- Handle camshaft sprocket (INT) carefully to avoid any shock to camshaft sprocket.
- Do not disassemble. [Do not loosen bolts (A) as shown].

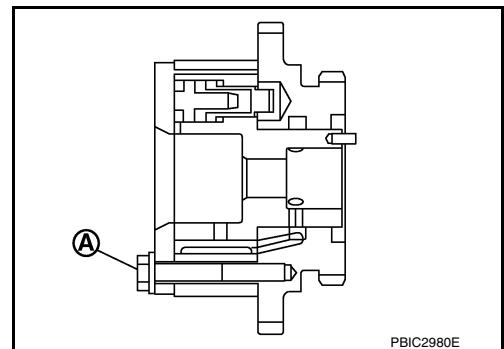

INSPECTION

TIMING CHAIN

< REMOVAL AND INSTALLATION >

Check for cracks and any excessive wear of the timing chain. Replace the timing chain as necessary.

INSTALLATION

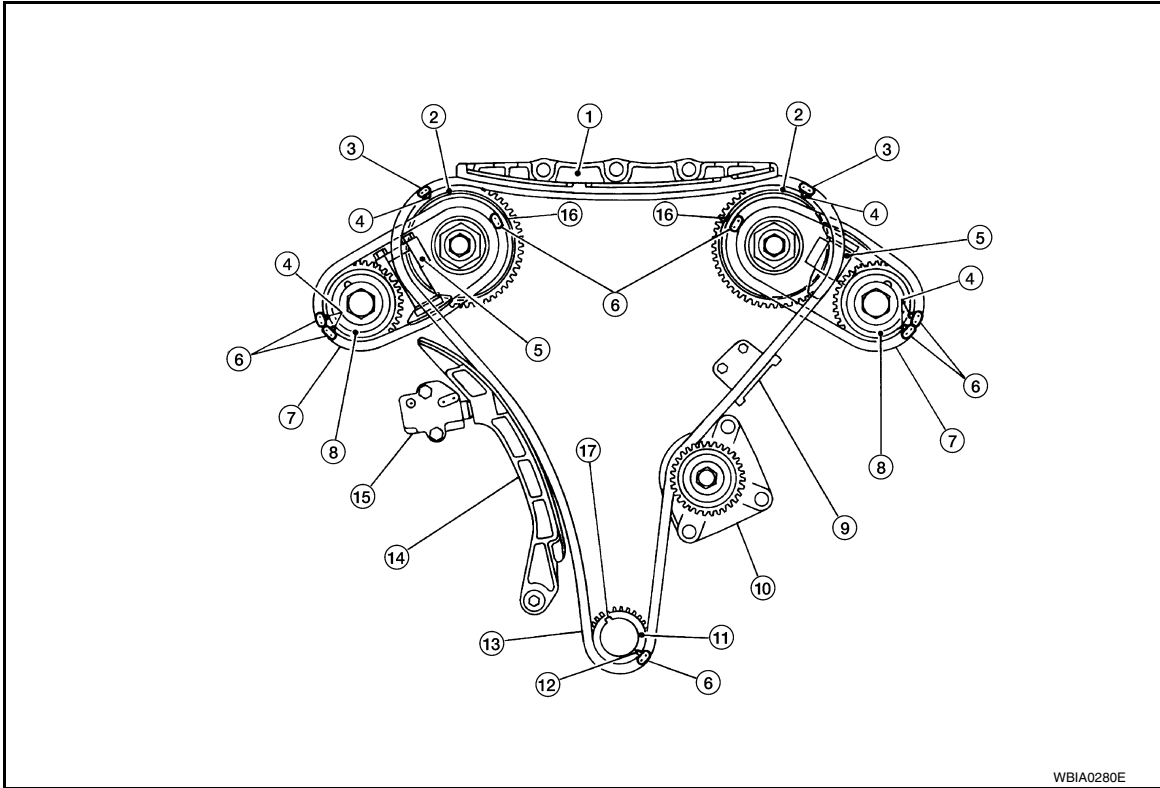

- | | | |
|-----------------------------|---------------------------------------|--------------------------------------|
| 1. Internal chain guide | 2. Camshaft sprocket (INT) | 3. Mating mark (green link) |
| 4. Mating mark (punched) | 5. Timing chain tensioner (secondary) | 6. Mating mark (orange link) |
| 7. Timing chain (secondary) | 8. Camshaft sprocket (EXH) | 9. Tension guide |
| 10. Water pump | 11. Crankshaft sprocket | 12. Mating mark (notched) |
| 13. Timing chain (primary) | 14. Slack guide | 15. Timing chain tensioner (primary) |
| 16. Mating mark (back side) | 17. Crankshaft key | |

NOTE:

This illustration shows the relationship between the mating mark on each timing chain and on the corresponding sprocket with the components installed.

1. Install timing chain tensioners (secondary) with a new O-ring and the stopper pin attached.

CAUTION:

Do not reuse O-ring.

2. Check that dowel pin (A) and crankshaft key (1) are located as shown. (No. 1 cylinder at compression TDC)

NOTE:

Though camshaft does not stop at the position as shown, for the placement of cam nose, it is generally accepted camshaft is placed in the same direction.

Camshaft dowel pin

: At cylinder head upper face side in each bank

Crankshaft key

: At cylinder head side of bank 1

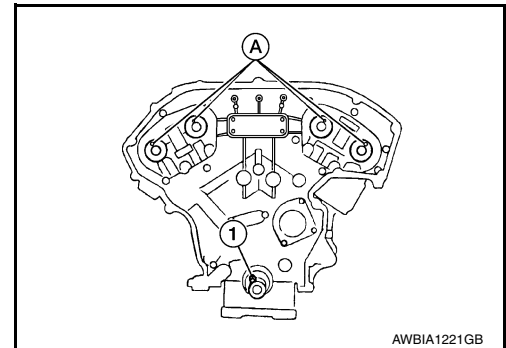

3. Install timing chain (secondary) and camshaft sprockets (INT and EXH) as follows:

CAUTION:

Mating marks between timing chain and sprockets slip easily. Confirm all mating mark positions repeatedly during the installation process.

TIMING CHAIN

< REMOVAL AND INSTALLATION >

- a. Push plunger of timing chain tensioner (secondary) and keep it pressed in with stopper pin (A).

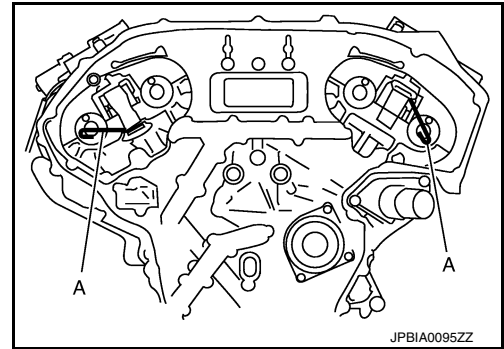

- b. Install timing chain (secondary) (2) and camshaft sprockets [INT (1) and EXH (3)].

- (A) : Dowel pin groove
- (B) : Mating mark (2 oblong on rear face)
- (C) : Orange link
- (D) : Mating mark (2 circles on rear face)
- (E) : Mating mark (Oblong on rear face)
- (F) : Dowel pin groove
- (G) : Mating mark (Circle on rear face)
- (H) : Orange link

NOTE:

Bank 1 shown (rear view).

- Align the mating marks on timing chain (secondary) (orange link) with the mating marks on camshaft sprockets (INT and EXH), and install them.
- Align dowel pin on camshafts with the groove on sprockets, and install them.
- Tighten the bolts for the camshaft sprockets by hand enough to prevent the dowel pins from falling out of the grooves.

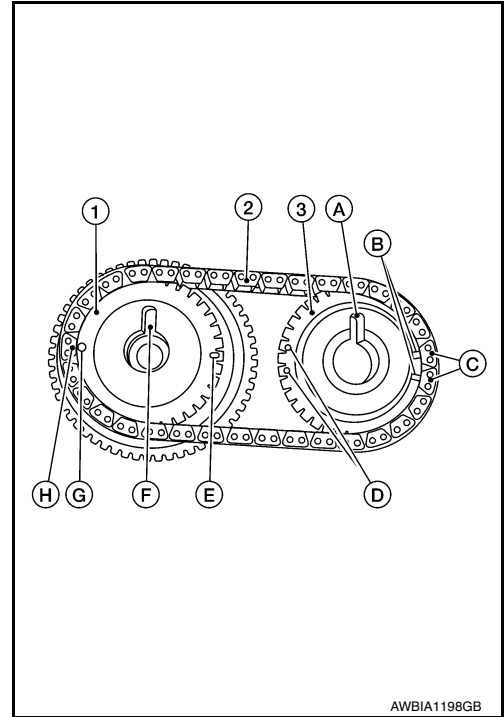

- It may be difficult to visually check the dislocation of mating marks during and after installation. To make the matching easier, make a mating mark (A) on the top of sprocket teeth and its extended line with paint.

- (B) : Mating mark (orange link)

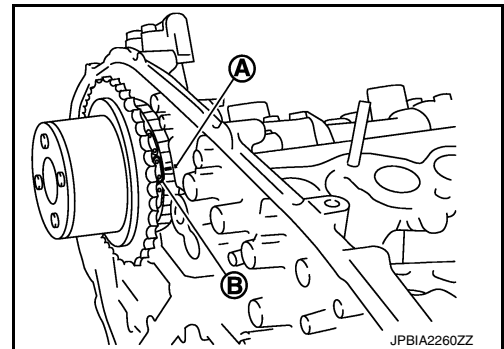

4. After confirming the mating marks are aligned, tighten the camshaft sprocket bolts.
 - Secure the camshaft using a wrench at the hexagonal portion to tighten the bolts.

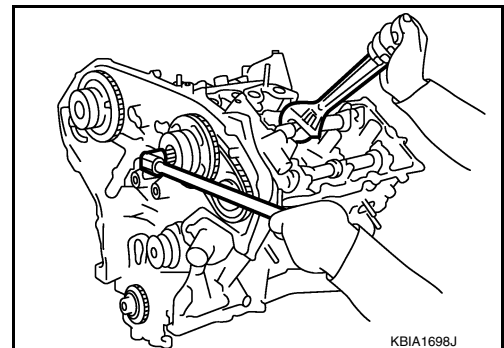

A
EM
C
D
E
F
G
H
I
J
K
L
M
N
O
P

TIMING CHAIN

< REMOVAL AND INSTALLATION >

5. Pull stopper pins (B) out from timing chain tensioners (secondary) (1).

- (A) : Bank 1
(C) : Bank 2

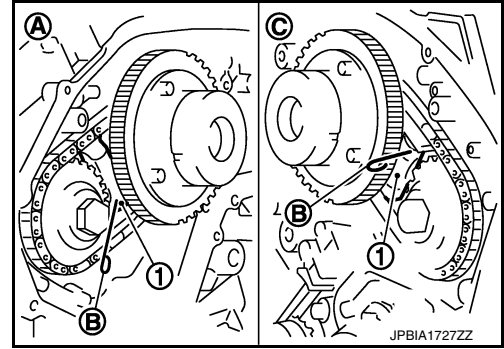

6. Install the crankshaft sprocket on the crankshaft.
• Make sure the mating marks on the crankshaft sprocket face the front of the engine.

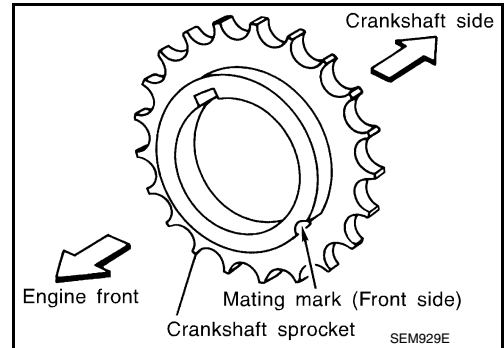

7. Install the timing chain (primary).
• Install timing chain (primary) so the mating mark (punched) (B) on camshaft sprocket (C) is aligned with the green link (A) on the timing chain, while the mating mark (notched) (E) on the crankshaft sprocket (D) is aligned with the orange one (F) on the timing chain, as shown.
• When it is difficult to align mating marks of the timing chain (primary) with each sprocket, gradually turn the camshaft using a wrench on the hexagonal portion to align it with the mating marks.
• During alignment, be careful to prevent dislocation of mating mark alignments of the secondary timing chains.

- (G) : Water pump

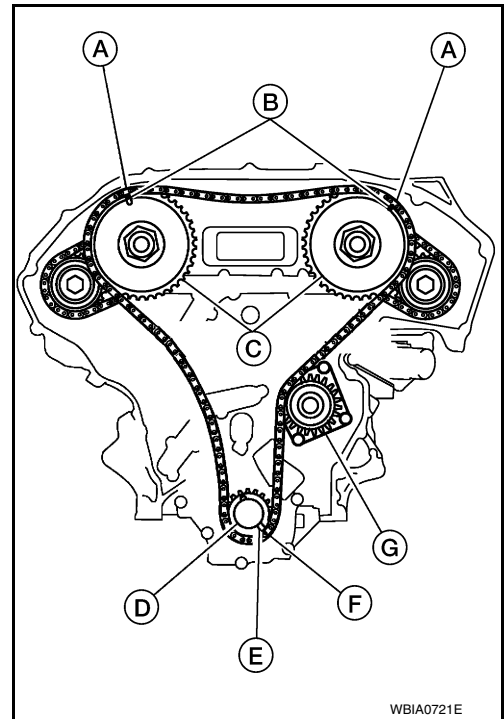

TIMING CHAIN

< REMOVAL AND INSTALLATION >

8. Install the internal chain guide (1) and slack guide (2).

(3) : Tension guide

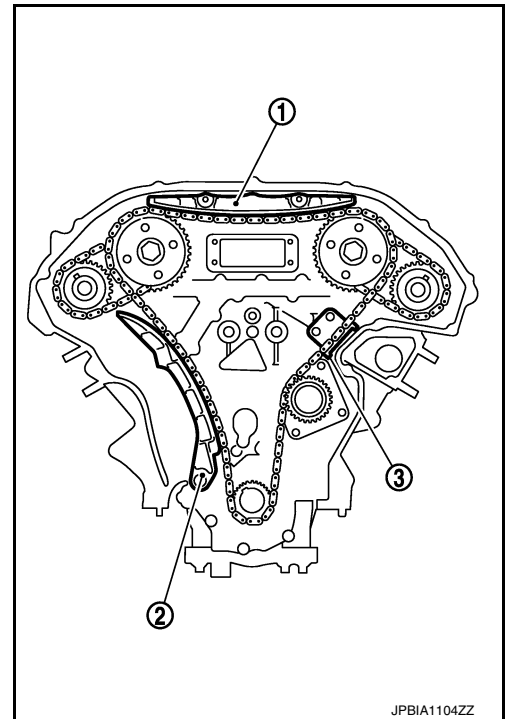

CAUTION:

Do not over tighten slack guide mounting bolt (2). It is normal for a gap (A) to exist under the bolt seat when bolt is tightened to specification.

(1) : Slack guide

(3) : Cylinder block

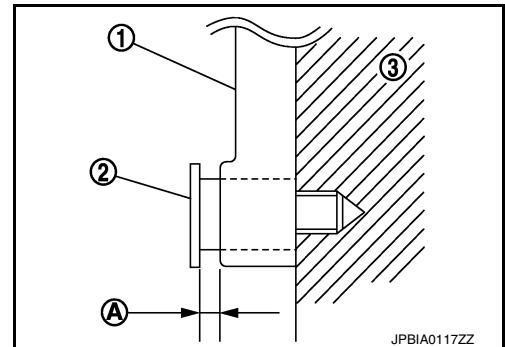

9. Install the timing chain tensioner (primary) with the following procedure:

a. Pull plunger stopper tab (A) up (or turn lever downward) so as to remove plunger stopper tab from the ratchet of plunger (D).

NOTE:

Plunger stopper tab and lever (C) are synchronized.

b. Push plunger into the inside of tensioner body.

c. Hold plunger in the fully compressed position by engaging plunger stopper tab with the tip of ratchet.

d. To secure lever, insert stopper pin (E) through hole of lever into tensioner body hole (B).

• The lever parts and the tab are synchronized. Therefore, the plunger will be secured under this condition.

NOTE:

Illustration shows the example of 1.2 mm (0.047 in) diameter thin screwdriver being used as the stopper pin.

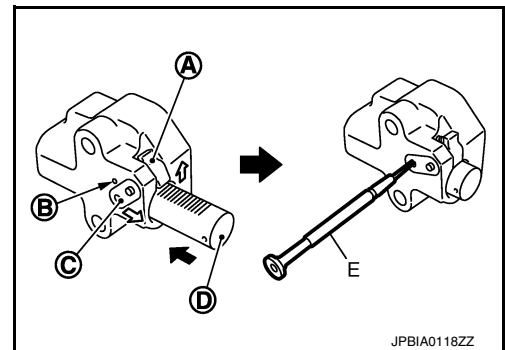

TIMING CHAIN

< REMOVAL AND INSTALLATION >

- e. Install timing chain tensioner (primary) (1).
 - Remove any dirt and foreign materials completely from the back and the mount surfaces of timing chain tensioner (primary).
- f. Pull out stopper pin (A) after installing, and then release plunger.

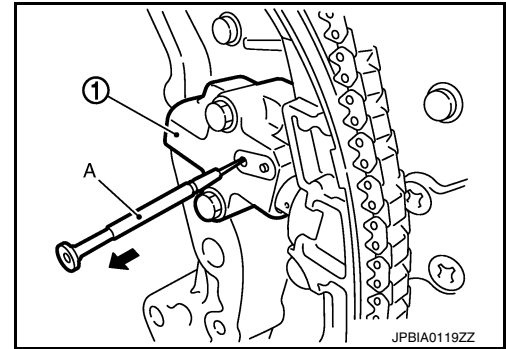

10. Reconfirm that the matching marks on the sprockets and the timing chain have not slipped out of alignment.
11. Install the front timing chain case. Refer to [EM-55, "Removal and Installation"](#).
12. Install the spark plugs. Refer to [EM-16, "Removal and Installation"](#).
13. Install the intake manifold collector. Refer to [EM-26, "Removal and Installation"](#).

REAR TIMING CHAIN CASE

< REMOVAL AND INSTALLATION >

REAR TIMING CHAIN CASE

Exploded View

INFOID:000000011148400

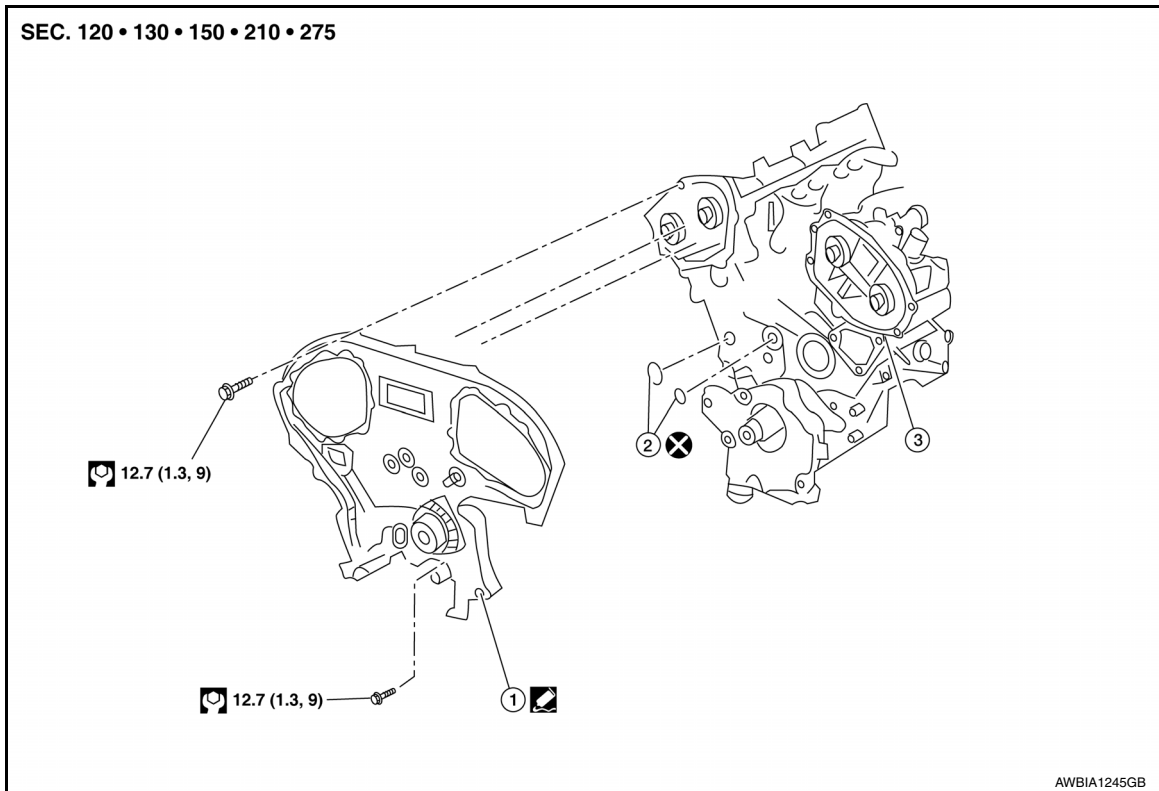

1. Rear timing chain case

2. O-ring

3. Cylinder block

Removal and Installation

INFOID:000000011148401

CAUTION:

- After removing timing chain, do not turn the crankshaft and camshaft separately, or the valves will strike the pistons.
- Before removing the upper oil pan, remove the crankshaft position sensor (POS).
- Be careful not to damage sensor edges.

REMOVAL

1. Remove the engine assembly. Refer to [EM-103, "2WD : Removal and Installation"](#) (2WD) or [EM-108, "4WD : Removal and Installation"](#) (4WD).
2. Remove upper oil pan. Refer to [EM-37, "Removal and Installation \(Upper Oil Pan\)"](#).
3. Remove the front timing chain case. Refer to [EM-55, "Exploded View"](#).
4. Remove the timing chains (primary) and (secondary). Refer to [EM-63, "Removal and Installation"](#).
5. Remove the rear timing chain case.

CAUTION:

- Do not remove the plate metal cover for the oil passage.
- After removing the chain case, do not apply any load to the case that might bend it.

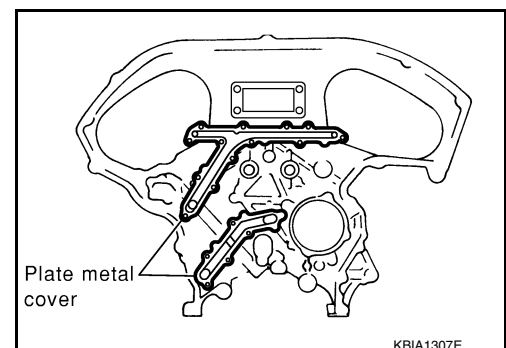

REAR TIMING CHAIN CASE

< REMOVAL AND INSTALLATION >

- a. Loosen and remove the rear timing chain case bolts in the reverse order shown.

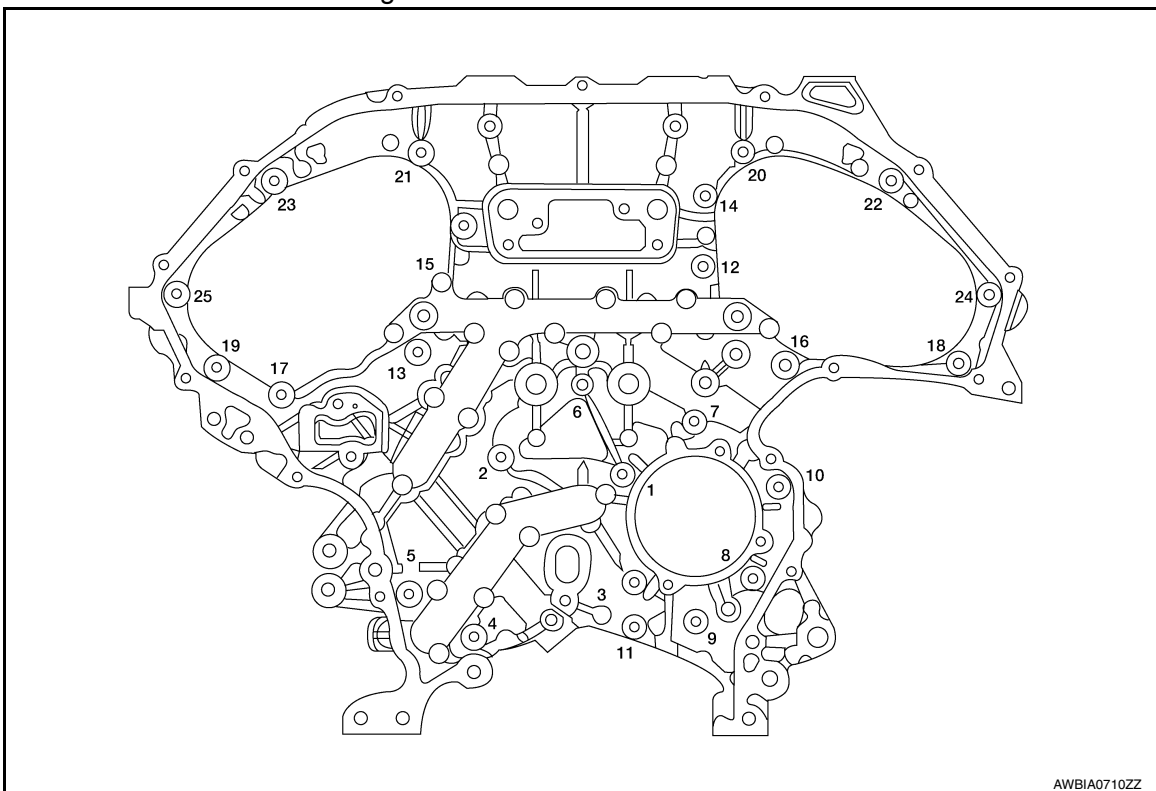

- b. Cut the sealant using Tool and remove the rear timing chain case.
• After removing the bolts, separate the mating surface and remove the old liquid gasket using Tool.

Tool number : KV10111100 (J-37228)

CAUTION:

Do not damage the mating surfaces.

- Tap the seal cutter to insert it (1).
- In areas where the Tool is difficult to use, lightly tap to slide it (2).

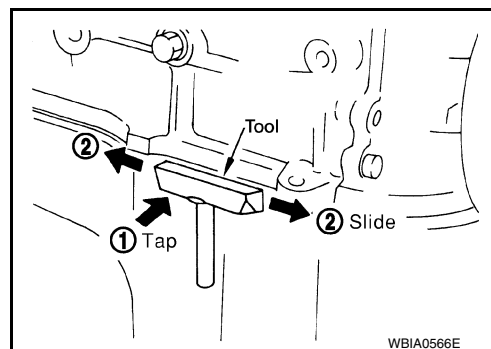

6. Remove O-rings (1) from cylinder block.

⇐ : Engine front

CAUTION:

Do not reuse O-rings.

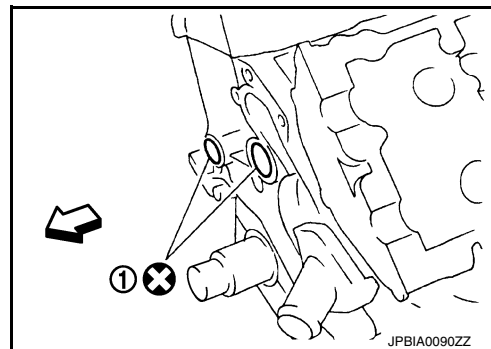

REAR TIMING CHAIN CASE

< REMOVAL AND INSTALLATION >

7. Use a scraper to remove all of the old Silicone RTV Sealant from the front and rear timing chain case and opposite mating surfaces.

CAUTION:

Do not damage the mating surfaces.

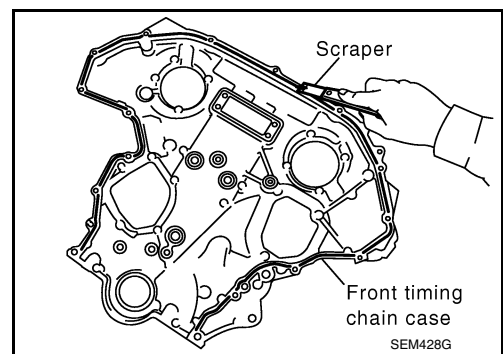

8. Remove all old Silicone RTV Sealant from all the bolt holes and bolts.

CAUTION:

Do not damage the threads or mating surfaces.

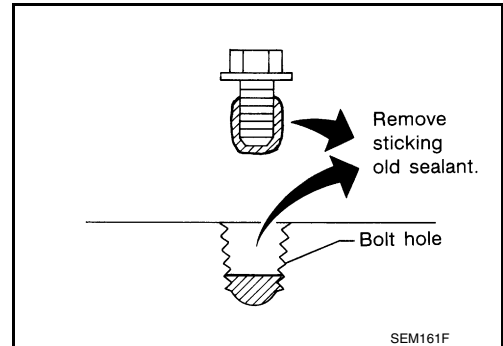

INSTALLATION

1. Install O-rings (1) on cylinder block.

⇐ : Engine front

CAUTION:

Do not reuse O-rings.

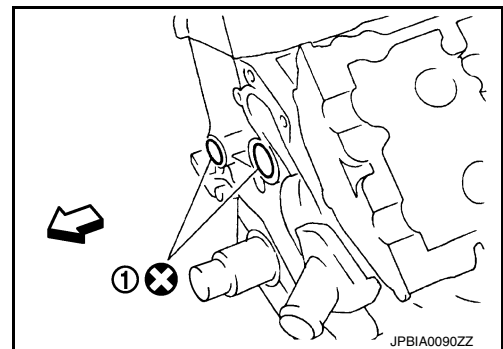

2. Apply Genuine Silicone RTV Sealant or equivalent, to the rear timing chain case using suitable tool as shown. Refer to [GI-22. "Recommended Chemical Products and Sealants"](#).

CAUTION:

- Installation should be done within 5 minutes after applying liquid gasket.
- Do not fill the engine with engine oil for at least 30 minutes after the components are installed to allow the sealant to cure.
- Wipe off liquid gasket where it touches the engine coolant passage at point "a".
- Follow the installation instructions for applying the liquid gasket. Pay particular attention to the water pump and cylinder area.

REAR TIMING CHAIN CASE

< REMOVAL AND INSTALLATION >

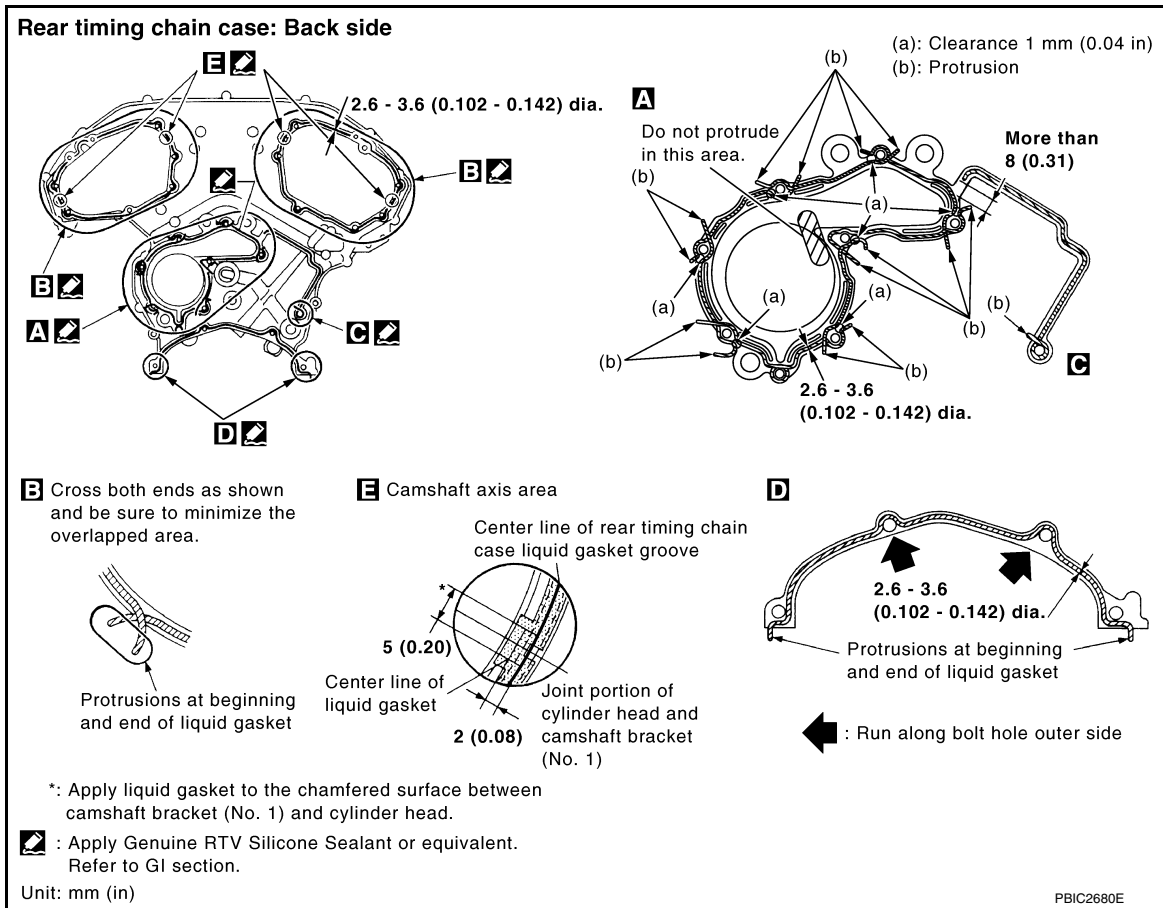

3. Align the rear timing chain case and water pump assembly with the dowel pins (RH and LH) on the cylinder block and install the case. Make sure the O-rings stay in place during installation.
 - a. Tighten the bolts in the numerical order as shown. There are two bolt lengths used. Follow the chart below for proper bolt length specifications.

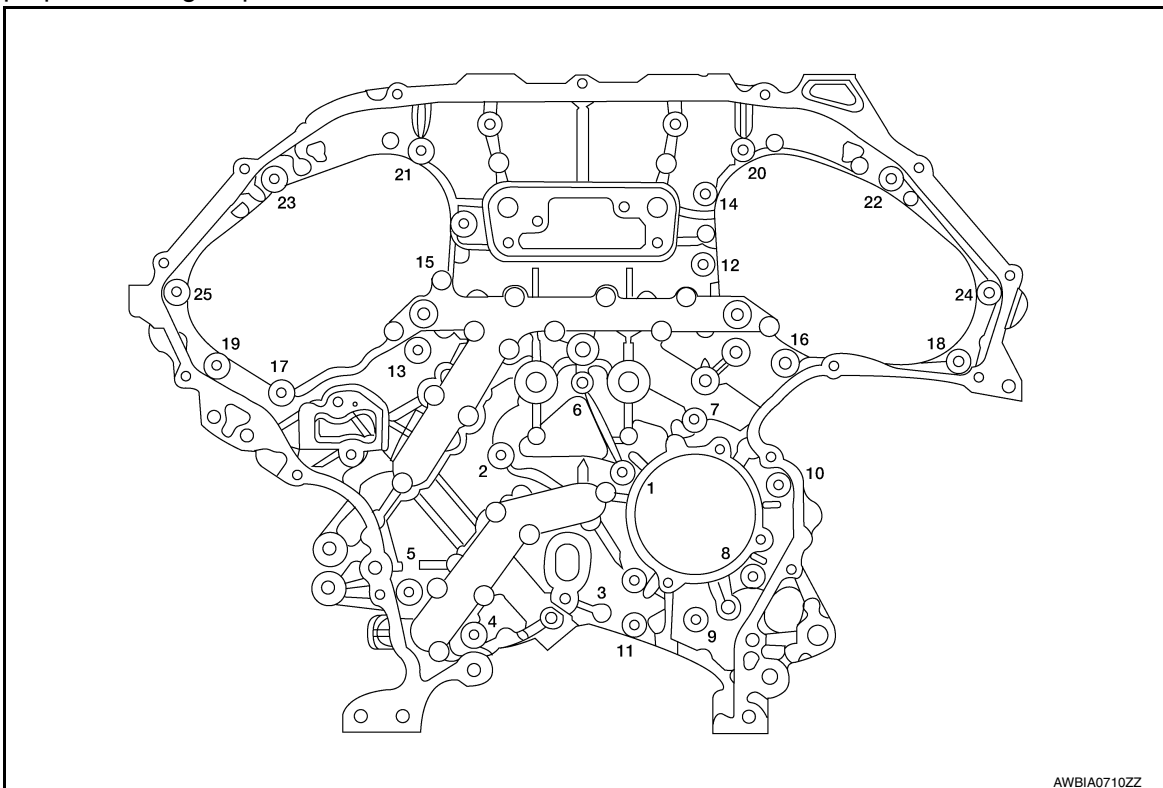

REAR TIMING CHAIN CASE

< REMOVAL AND INSTALLATION >

| Bolt length | Bolt position | Torque specification |
|-----------------|-------------------------|------------------------------|
| 20 mm (0.79 in) | 1, 2, 3, 6, 7, 8, 9, 10 | 12.7 N·m (1.3 kg-m, 9 ft-lb) |
| 16 mm (0.63 in) | All except the above | 12.7 N·m (1.3 kg-m, 9 ft-lb) |

- b. After all bolts are initially tightened, retighten them to the specification in the numerical order as shown.

NOTE:

If liquid gasket protrudes, wipe it off immediately.

4. Install the timing chains (primary and secondary). Refer to [EM-63. "Removal and Installation"](#).
5. Install the front timing chain case. Refer to [EM-55. "Removal and Installation"](#).
6. Install the upper oil pan. Refer to [EM-37. "Removal and Installation \(Upper Oil Pan\)"](#).
7. Install the engine assembly. Refer to [EM-103. "2WD : Removal and Installation"](#) (2WD) or [EM-108. "4WD : Removal and Installation"](#) (4WD).

A

EM

C

D

E

F

G

H

I

J

K

L

M

N

O

P

CAMSHAFT

< REMOVAL AND INSTALLATION >

CAMSHAFT

Exploded View

INFOID:000000011148402

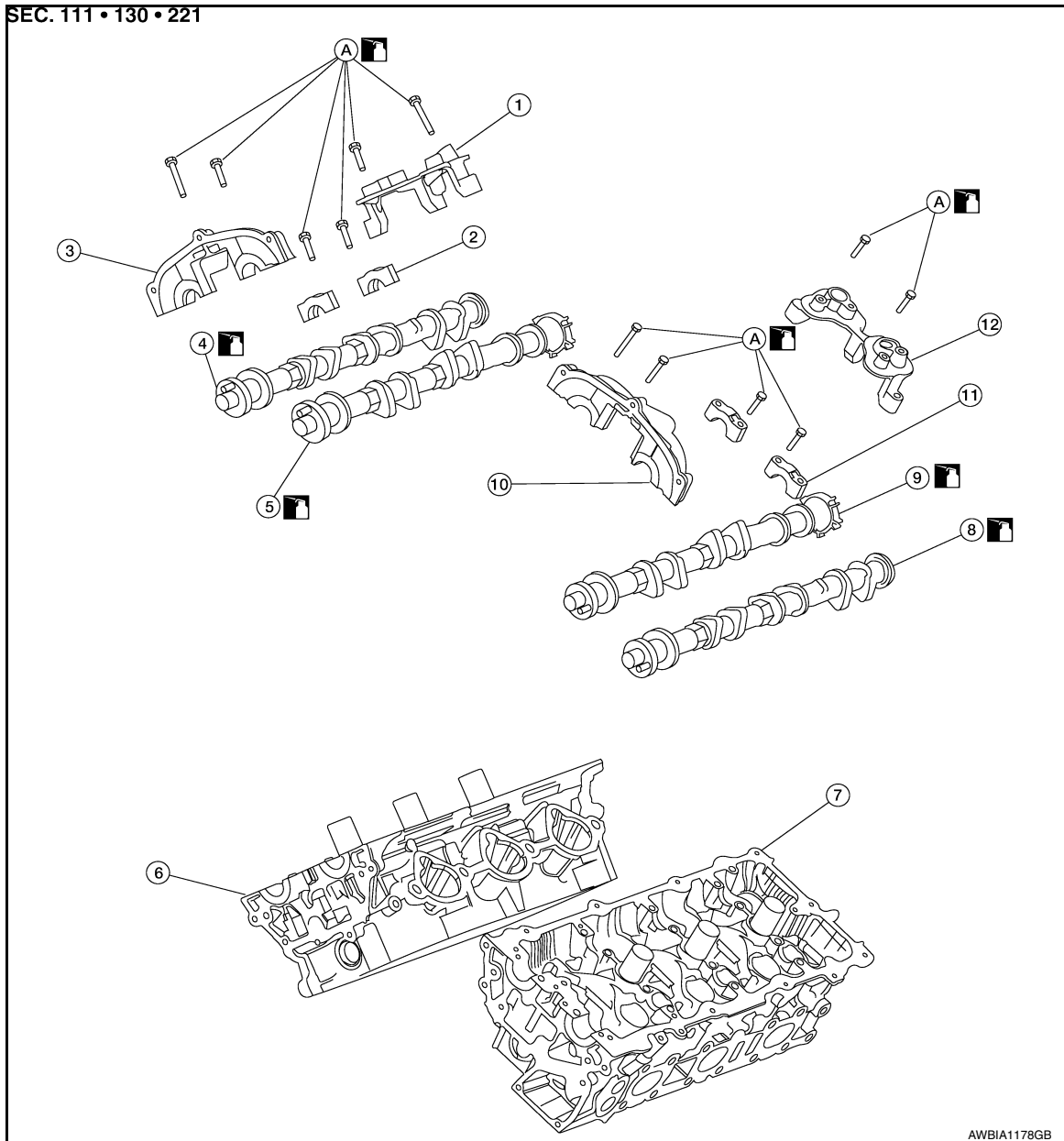

- | | | |
|--|------------------------|---|
| 1. Camshaft position sensor bracket (RH) | 2. Camshaft brackets | 3. No. 1 camshaft bracket (RH) |
| 4. Camshaft (EXH) (RH) | 5. Camshaft (INT) (RH) | 6. Cylinder head (RH) |
| 7. Cylinder head (LH) | 8. Camshaft (EXH) (LH) | 9. Camshaft (INT) (LH) |
| 10. No. 1 camshaft bracket (LH) | 11. Camshaft brackets | 12. Camshaft position sensor bracket (LH) |
| A. Refer to INSTALLATION | | |

CAUTION:

Apply new engine oil to parts marked in illustration before installation.

Removal and Installation

INFOID:000000011148403

REMOVAL

CAMSHAFT

< REMOVAL AND INSTALLATION >

1. Remove the timing chains (primary and secondary). Refer to [EM-63, "Removal and Installation"](#).
2. Remove camshaft position brackets (RH shown, LH similar).

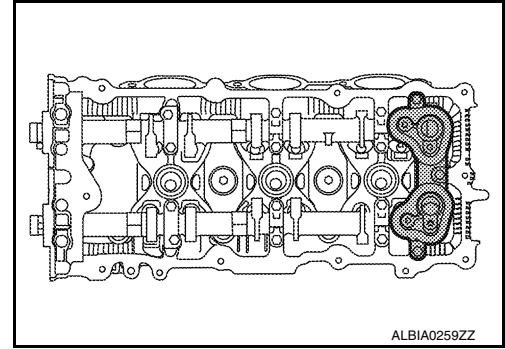

3. Remove the intake and exhaust camshaft brackets and the camshafts.
 - Mark the camshafts, camshaft brackets, and bolts so they are placed in the same position and direction for installation.
 - Equally loosen the camshaft bracket bolts in several steps in the numerical order as shown.

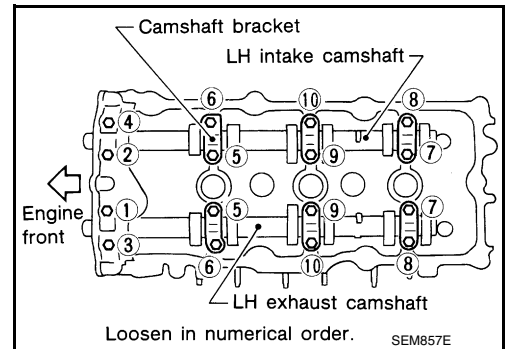
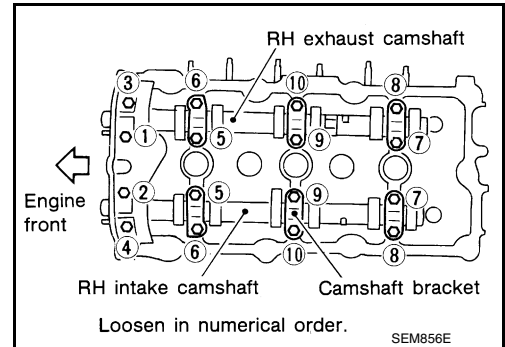

4. Remove valve lifters if necessary.
NOTE:
Identify installation positions to ensure proper installation.
5. Remove secondary timing chain tensioner (1) from cylinder head.
 - Remove secondary tensioner with its stopper pin attached.**NOTE:**
Stopper pin was attached when secondary timing chain was removed.

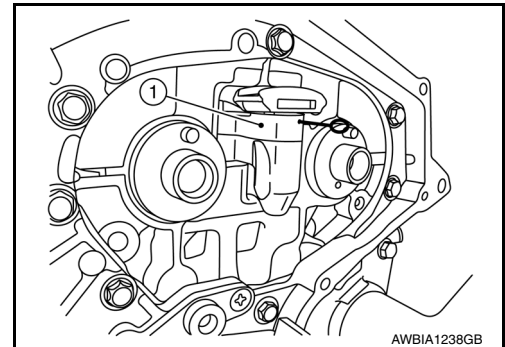

INSTALLATION

CAMSHAFT

< REMOVAL AND INSTALLATION >

1. Before installation, remove any old Silicone RTV Sealant from component mating surfaces using a scraper.
 - Remove the old Silicone RTV Sealant from the bolt holes and threads.
 - Do not scratch or damage the mating surfaces.

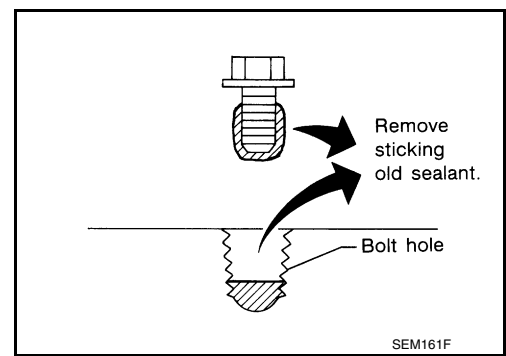

2. Before installing the front cam bracket, remove the old Silicone RTV Sealant from the mating surface using a scraper.
 - Do not scratch or damage the mating surface.

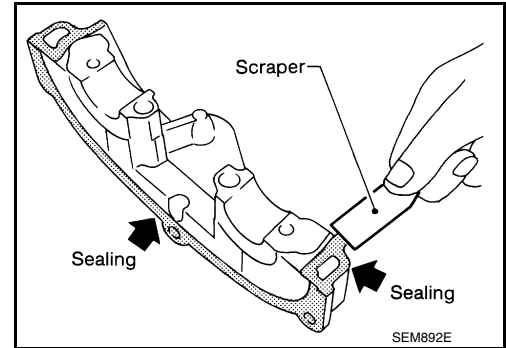

3. Turn the crankshaft until No. 1 piston is set at TDC on the compression stroke.
 - The crankshaft key should line up with the right bank cylinder center line as shown.

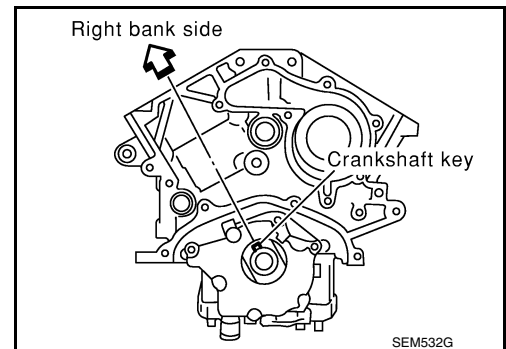

4. Install camshaft chain tensioners (1) on both sides of cylinder head. Refer to [EM-55. "Removal and Installation"](#).

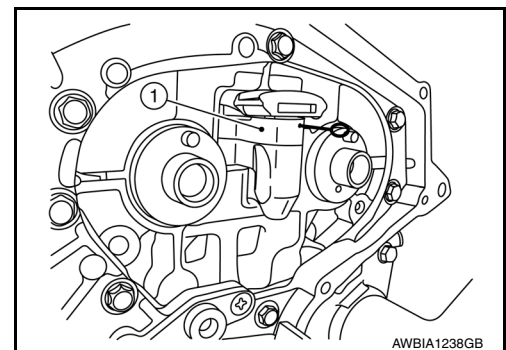

5. Install valve lifter, if removed.
NOTE:
Install them in original positions.

CAMSHAFT

< REMOVAL AND INSTALLATION >

6. Install exhaust and intake camshafts and camshaft brackets.
 - Intake camshaft has a drill mark on camshaft sprocket mounting flange.

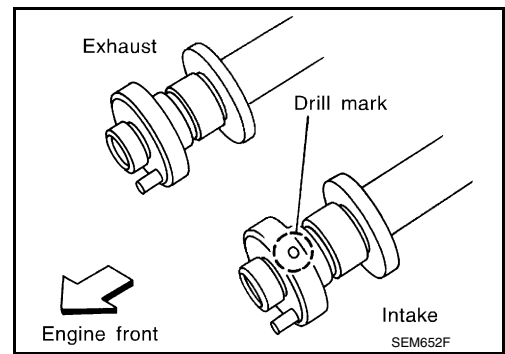

- Follow your identification marks made during removal or follow the identification marks that are present on the new camshafts components for proper placement and direction of the components.

| Bank | INT/EXH | ID mark (A) | Drill mark | Paint marks | | |
|--------|---------|-------------|------------|-------------|------------|------------|
| | | | | M1 (E) | M2 (F) | M3 (D) |
| RH (B) | INT | 1A | Yes | Pink | No | Light blue |
| | EXH | 1C | No | No | Light Blue | Light blue |
| LH (C) | INT | 1B | Yes | Pink | No | Light blue |
| | EXH | 1D | No | No | Light Blue | Light blue |

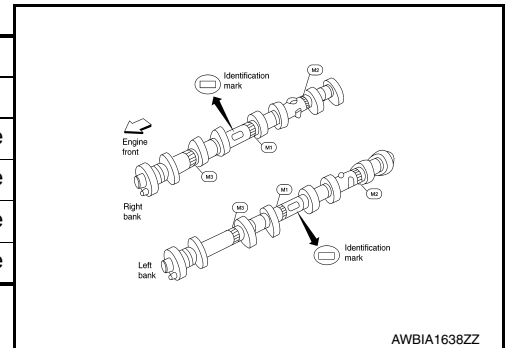

- Position the camshaft dowel pins (A) as shown.

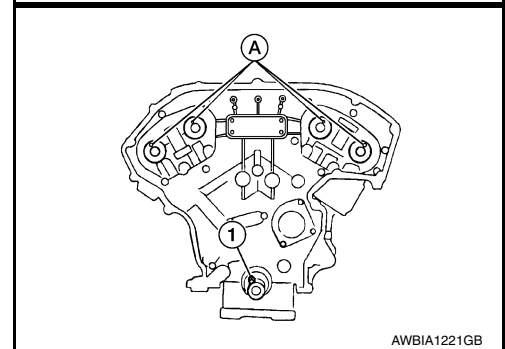

A
EM
C
D
E
F
G
H
I
J
K
L
M
N
O
P

CAMSHAFT

< REMOVAL AND INSTALLATION >

7. Before installing camshaft brackets, apply liquid gasket to mating surface of No. 1 camshaft bracket.
- Use Genuine Silicone RTV Sealant or equivalent. Refer to [GI-22, "Recommended Chemical Products and Sealants"](#).
- CAUTION:**
- Installation should be done within 5 minutes after applying liquid gasket.
 - Do not fill the engine with engine oil for at least 30 minutes after the components are installed to allow the liquid gasket to cure.

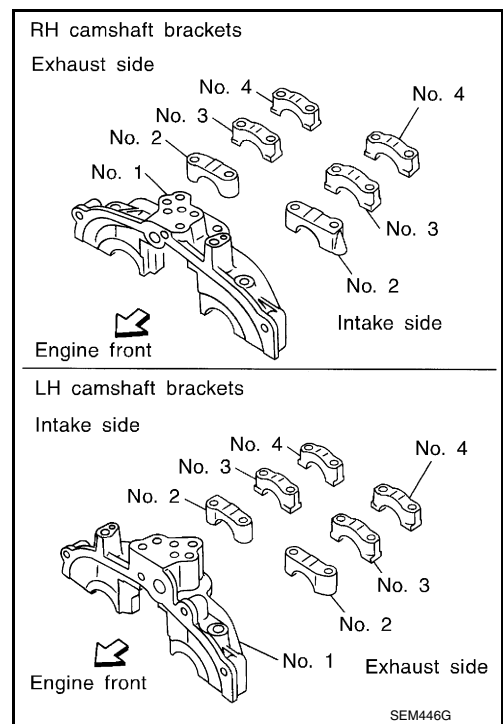

- Before installation, wipe off any protruding liquid gasket.
- Refer to [EM-4, "Precaution for Liquid Gasket"](#).

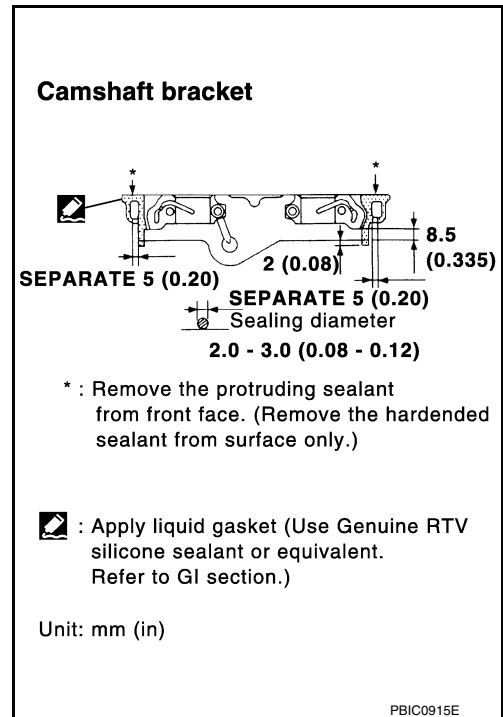

- Install camshaft brackets in their original positions and direction. Align the stamp marks as shown.
- If checking and adjusting any part of valve assembly or camshaft, check valve clearance according to the reference data. Refer to [EM-18, "Valve Clearance"](#).

Valve clearance (cold) Intake : 0.26 - 0.34 mm (0.010 - 0.013 in)

Valve clearance (cold) Exhaust : 0.29 - 0.37 mm (0.011 - 0.015 in)

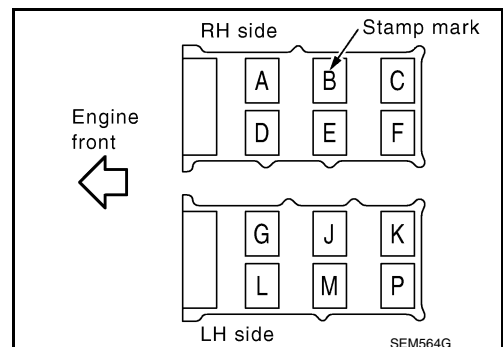

CAMSHAFT

< REMOVAL AND INSTALLATION >

- Tighten the camshaft brackets in three steps, in numerical order shown.

| | | |
|-----|--------------------------------|--|
| (1) | 1.96 N·m (0.2 kg-m, 17 in-lb) | Tighten No. 7 - 10, then tighten No. 1 - 6 in the numerical order shown. |
| (2) | 5.88 N·m (0.6 kg-m, 52 in-lb) | Tighten No. 1 - 10 in the numerical order shown. |
| (3) | 10.41 N·m (1.10 kg-m, 8 ft-lb) | Tighten No. 1 - 10 in the numerical order shown. |

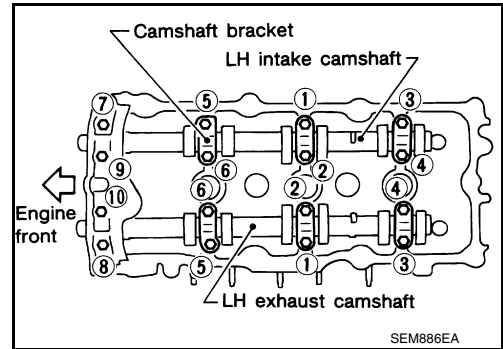
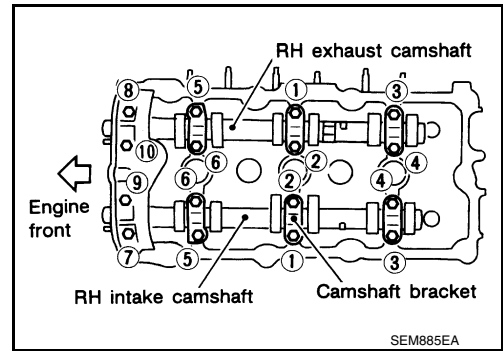

- Measure difference in levels between front end faces of No. 1 camshaft bracket and cylinder head.

Standard : - 0.14 to 0.14mm (- 0.0055 to 0.0055 in)

- If measurement is outside the specified range, re-install camshaft and camshaft bracket.

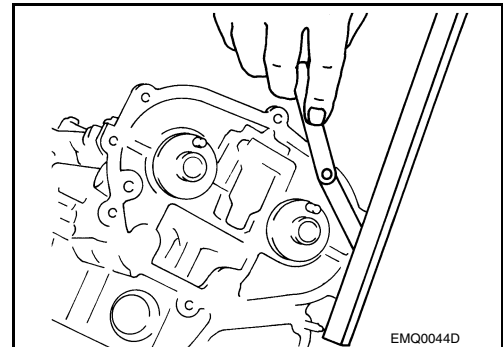

- Install camshaft position sensors (PHASE) (RH and LH bank.)
- Install the timing chains. Refer to [EM-63, "Removal and Installation"](#).

Inspection After Removal

INFOID:000000011148404

INSPECTION

Camshaft Visual Check

Check camshaft for scratches and wear. Replace if necessary.

Camshaft Runout

CAMSHAFT

< REMOVAL AND INSTALLATION >

1. Put V-block on precise flat bed and support No. 2 and No. 4 journal of camshaft as shown.
2. Set dial gauges vertically to No. 3 journal as shown.
3. Turn camshaft in one direction slowly by hand measure the camshaft runout on the dial gauges.
 - Runout is the largest indicator reading after one full revolution.

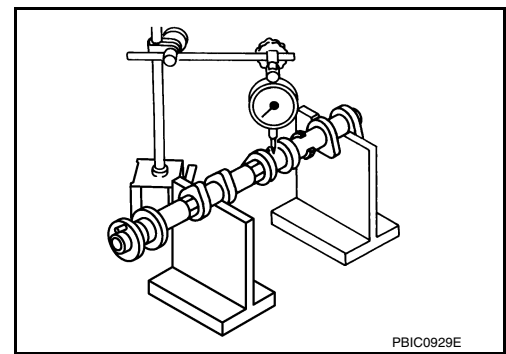

Camshaft Runout

Standard : Less than 0.02 mm (0.0008 in)

Limit : 0.05 mm (0.0020 in)

4. If actual runout exceeds the limit, replace the camshaft.

Camshaft Lobe Height

1. Measure camshaft lobe height as shown. Refer to [EM-135, "Camshaft"](#).
2. If wear has reduced the camshaft lobe height below specifications, replace the camshaft.

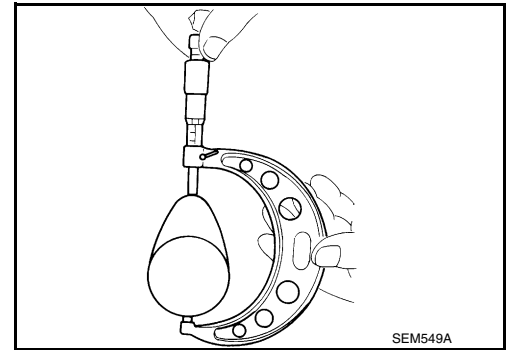

Camshaft Journal Clearance

Outer Diameter of Camshaft Journal

- Measure outer diameter of camshaft journal as shown.

Standard outer diameter : 25.935 - 25.955 mm
No.1 (1.0211 - 1.0218 in)

Standard outer diameter : 23.445 - 23.465 mm
No.2, 3, 4 (0.9230 - 0.9238 in)

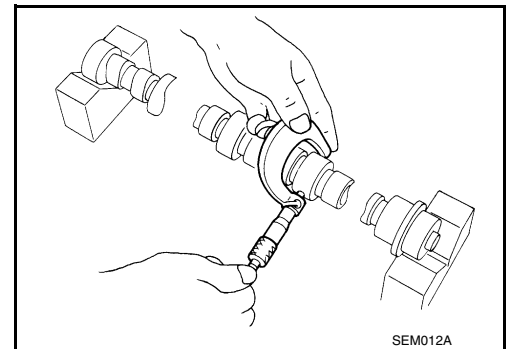

Inner Diameter of Camshaft Bracket

1. Tighten camshaft bracket bolt with specified torque.
2. Using inside micrometer, measure inner diameter (A) of camshaft bracket.

Standard inner diameter : 26.000 - 26.021 mm
No.1 (1.0236 - 1.0244 in)

Standard inner diameter : 23.500 - 23.521 mm
No.2, 3, 4 (0.9252 - 0.9260 in)

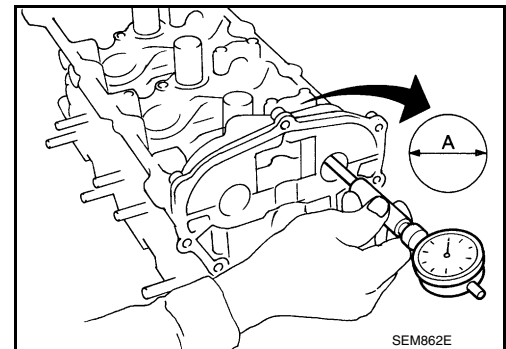

Calculation of Camshaft Journal Clearance

(Journal clearance) = (inner diameter of camshaft bracket) – (outer diameter of camshaft journal)

CAMSHAFT

< REMOVAL AND INSTALLATION >

Standard No.1 : 0.045 - 0.086 mm (0.0018 - 0.0034 in)

Standard No.2, 3, 4 : 0.035 - 0.076 mm (0.0014 - 0.0030 in)

Limit : 0.15 mm (0.0059 in)

- When out of the specified range, replace either or both camshaft and cylinder head.

NOTICE:

Inner diameter of camshaft bracket is manufactured together with cylinder head. Replace the whole cylinder head assembly.

Camshaft End Play

1. Install the camshaft in the cylinder head.
2. Install dial gauge in thrust direction on front end of camshaft. Measure end play when camshaft is moved forward/backward (in direction to axis) as shown.

Standard : 0.115 - 0.188 mm (0.0045 - 0.0074 in)

Limit : 0.24 mm (0.0094 in)

- If out of the specified range, replace with new camshaft and measure again.
- If out of the specified range again, replace with new cylinder head.

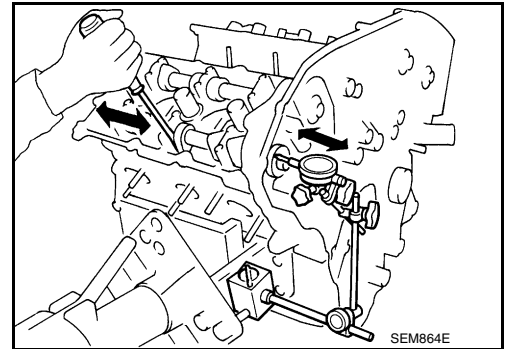

Camshaft Sprocket Runout

1. Put V-block on precise flat bed and support No. 2 and No. 4 journal of camshaft as shown.
2. Install camshaft sprocket on camshaft.
3. Measure camshaft sprocket runout.

Runout : Less than 0.15 mm (0.0059 in)

4. If sprocket runout exceeds the limit, replace camshaft sprocket.

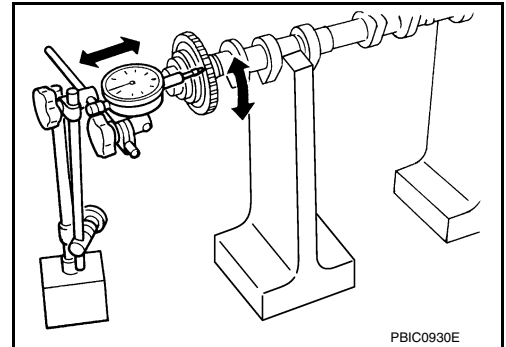

Valve Lifter

- Check if the surface of the valve lifter has any excessive wear or cracks replace as necessary.

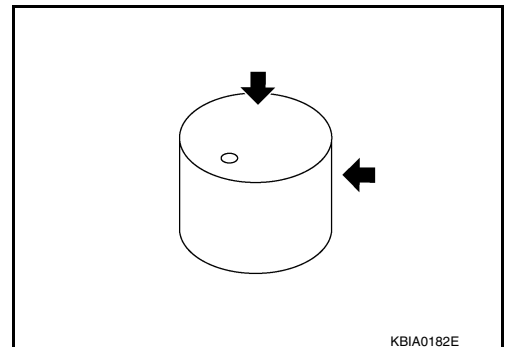

Valve Lifter Clearance

Outer Diameter of Valve Lifter

CAMSHAFT

< REMOVAL AND INSTALLATION >

- Measure the outer diameter of the valve lifter. Refer to [EM-135, "Camshaft"](#).
- If out of the specified range, replace the valve lifter.

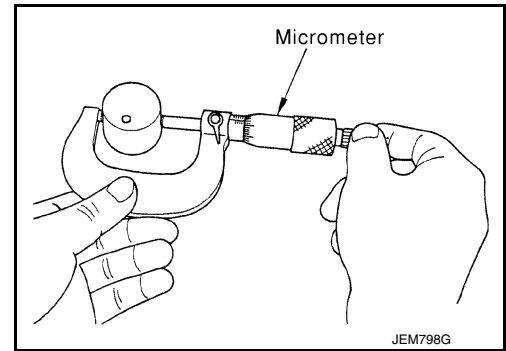

Valve Lifter Bore Diameter

- Using inside micrometer, measure diameter of valve lifter bore of cylinder head. Refer to [EM-135, "Camshaft"](#).
- If out of the specified range, replace the cylinder head assembly.

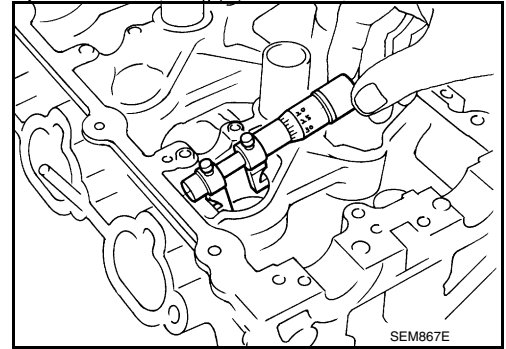

Calculation of Valve Lifter Clearance

- (Valve lifter clearance) = (valve lifter bore diameter) – (valve lifter outer diameter) Refer to [EM-135, "Camshaft"](#).
- If out of specified range, replace either or both valve lifter and cylinder head assembly.

Inspection after Installation

INFOID:000000011148405

INSPECTION OF CAMSHAFT SPROCKET (INT) OIL GROOVE

CAUTION:

Perform this inspection only when DTC P0011 is detected in self-diagnostic results of CONSULT and it is directed according to inspection procedure of EC section. Refer to [EC-197, "Diagnosis Procedure"](#).

WARNING:

Check when engine is cold so as to prevent burns from any splashing engine oil.

1. Check engine oil level. Refer to [LU-8, "Inspection"](#).
2. Perform the following procedure so as to prevent the engine from being unintentionally started while checking.
 - a. Release fuel pressure. Refer to [EC-168, "Work Procedure"](#).
 - b. Disconnect ignition coil and injector harness connectors if practical.
3. Remove intake valve timing control solenoid valve.
4. Crank engine, and then make sure that engine oil comes out from intake valve timing control cover oil hole. End cranking after checking.

WARNING:

Be careful not to touch rotating parts (drive belts, idler pulley, and crankshaft pulley, etc.).

CAUTION:

- Engine oil may squirt from intake valve timing control solenoid valve installation hole during cranking. Use a shop cloth to prevent engine oil from splashing on worker, engine components and vehicle.
- Do not allow engine oil to get on rubber components such as drive belts or engine mount insulators. Immediately wipe off any splashed engine oil.

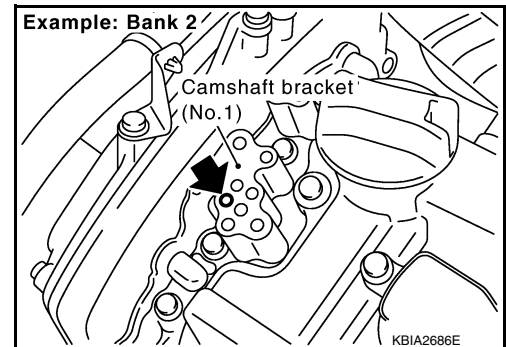

CAMSHAFT

< REMOVAL AND INSTALLATION >

5. Clean oil groove between oil strainer and intake valve timing control solenoid valve if engine oil does not come out from intake valve timing control cover oil hole. A
6. Remove components between intake valve timing control solenoid valve and camshaft sprocket (INT), and then check each oil groove for clogging.
 - Clean oil groove if necessary. EM
7. After inspection, installation of the remaining components is in the reverse order of removal.

C

D

E

F

G

H

I

J

K

L

M

N

O

P

OIL SEAL

< REMOVAL AND INSTALLATION >

OIL SEAL

Removal and Installation of Valve Oil Seal

INFOID:000000011148406

REMOVAL

1. Turn crankshaft until the cylinder requiring new oil seals is at TDC. This will prevent valve from dropping into cylinder.

CAUTION:

When rotating crankshaft, be careful to avoid scarring the front cover with the timing chain.

2. Remove camshaft relating to valve oil seal to be removed. Refer to [EM-76, "Removal and Installation"](#).
3. Remove valve lifters. Refer to [EM-76, "Removal and Installation"](#).
4. Remove valve collet, valve spring retainer and valve spring using Tool.

CAUTION:

When working, take care not to damage valve lifter bore.

Tool numbers : KV10116200 (J-26336-A)
: KV10115900 (J-26336-20)
: KV10109220 (—)

- Compress valve spring using Tool, attachment and adapter. Remove valve collet with magnet hand.

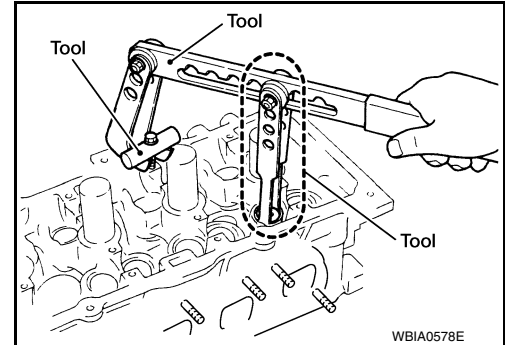

5. Remove valve oil seal using Tool.

Tool number : KV10107902 (J-38959)

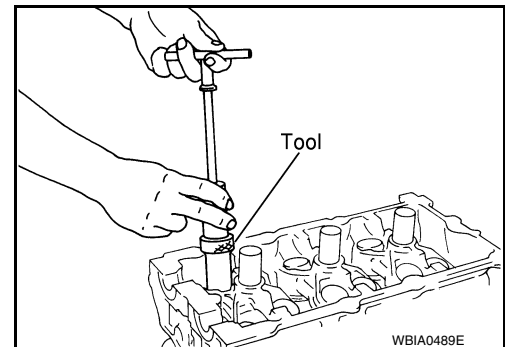

INSTALLATION

1. Apply new engine oil to new valve oil seal joint surface and seal lip.
2. Press in valve oil seal to height (H) using Tool to specified height.

Tool number : KV10115600 (J-38958)

NOTE:

Dimension (H): height measured before valve spring seat installation.

Intake and exhaust (H) : 14.3 - 14.9 mm (0.563 - 0.587 in)

3. Installation of the remaining components is in the reverse order of removal.

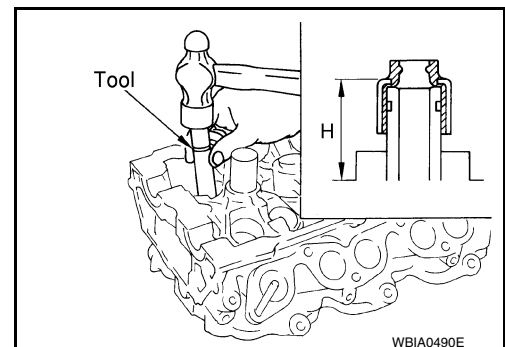

Removal and Installation of Front Oil Seal

INFOID:000000011148407

REMOVAL

1. Remove drive belt. Refer to [EM-12, "Removal and Installation"](#).
2. Lock the drive plate using Tool.

OIL SEAL

< REMOVAL AND INSTALLATION >

Tool number : — (J-50288)

CAUTION:

Do not damage the ring gear teeth or the signal plate teeth behind the ring gear when setting the Tool.

3. Remove the crankshaft pulley as follows:
 - a. Loosen crankshaft pulley and locate bolt seating surface at 10 mm (0.39 in) from its original position.
 - b. Position a pulley puller at recess hole of crankshaft pulley to remove crankshaft pulley.

CAUTION:

Do not use a puller claw on the outer diameter of the crankshaft pulley.

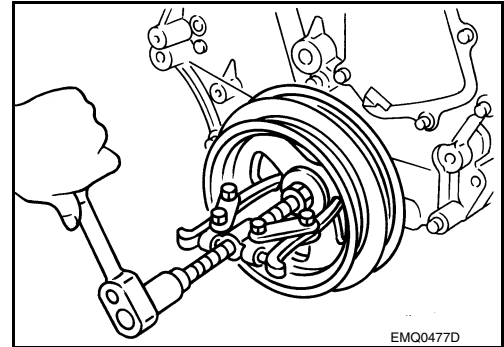

4. Remove front oil seal from front cover using a suitable tool.

CAUTION:

Be careful not to damage front cover or crankshaft.

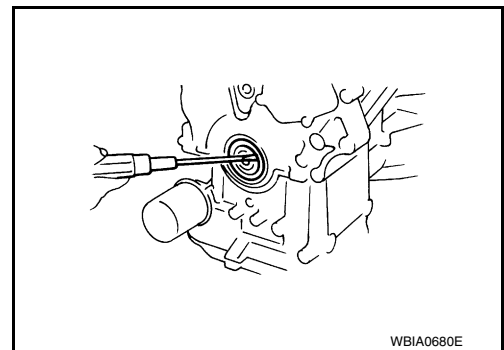

INSTALLATION

1. Apply new engine oil to new oil seal and install.
 - Install new oil seal in the direction as shown.

CAUTION:

- Do not reuse front oil seal.
- Press fit straight and avoid causing burrs or tilting the oil seal.

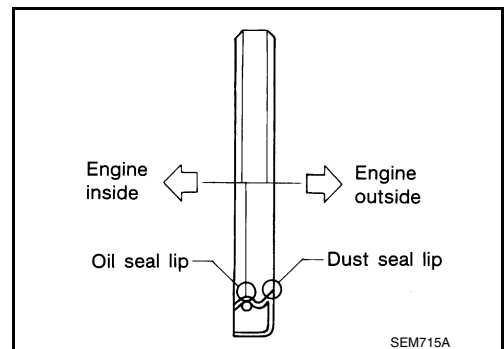

- Press-fit oil seal until it becomes flush with the timing chain case end face, using suitable tool.
- Make sure the garter spring in the oil seal is in position and seal lip is not inverted.

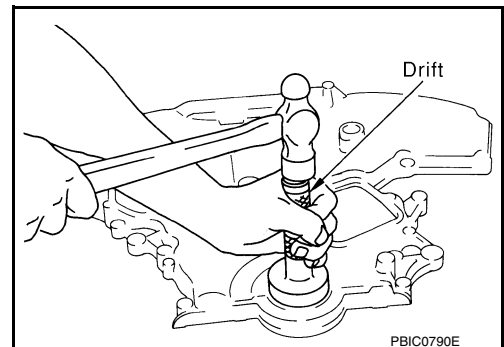

2. Install crankshaft pulley and tighten the bolt in two steps.

OIL SEAL

< REMOVAL AND INSTALLATION >

- Lubricate thread and seat surface of the bolt with new engine oil.
- For the second step angle tighten using Tool.

CAUTION:

- Do not damage the front oil seal when inserting crankshaft pulley.
- Use only brass or plastic hammer if tapping on the crankshaft pulley.
- Do not hammer on pulley grooves.

Step 1 : 44.1 N·m (4.5 kg-m, 33 ft-lb)

Step 2 : 90°(+0°/-6°) degrees clockwise

Tool number : KV10112100 (BT-8653-A)

3. Remove the Tool to unlock the driveplate.

Tool number : — (J-50288)

CAUTION:

Do not damage the ring gear teeth, or the signal plate teeth behind the ring gear, when removing the Tool.

4. Installation of the remaining components is in the reverse order of removal.

Removal and Installation of Rear Oil Seal

INFOID:000000011148408

REMOVAL

1. Remove the upper oil pan. Refer to [EM-37, "Removal and Installation \(Upper Oil Pan\)"](#).
2. Remove drive plate. Refer to [EM-132, "Dowel Pin Alignment"](#).
3. Remove rear oil seal retainer using Tool.

Tool Number : KV10111100 (J-37228)

CAUTION:

- Be careful not to damage mating surface.
- If rear oil retainer is removed, replace it with a new one

NOTE:

Rear oil seal and retainer form a single part and are replaced as an assembly.

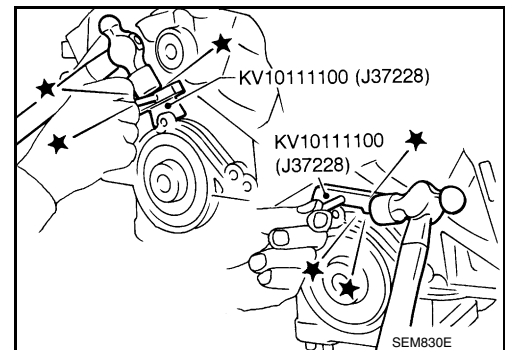

INSTALLATION

1. Remove old liquid gasket material from mating surface of cylinder block and oil pan using a suitable scraper.
2. Install the rear oil seal retainer using Tool (A).

Tool number (A) : — (J-47128)

- a. Loosen the wing nut (B) on the end of the Tool (A).
- b. Insert the arbor (D) into the crankshaft pilot hole until the outer lip (C) of the Tool (A) covers the edge of the crankshaft sealing surface.
- c. Tighten the wing nut (B) to secure the Tool (A) to the crankshaft.

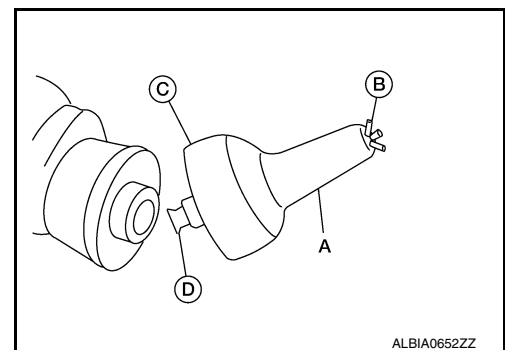

OIL SEAL

< REMOVAL AND INSTALLATION >

- d. Apply sealant to rear oil seal retainer as shown.
Use **Genuine Silicone RTV Sealant** or equivalent. Refer to [GI-22, "Recommended Chemical Products and Sealants"](#).

CAUTION:

- Installation should be done within 5 minutes after applying liquid gasket.
- Do not fill the engine with engine oil for at least 30 minutes after the components are installed to allow the liquid gasket to cure.

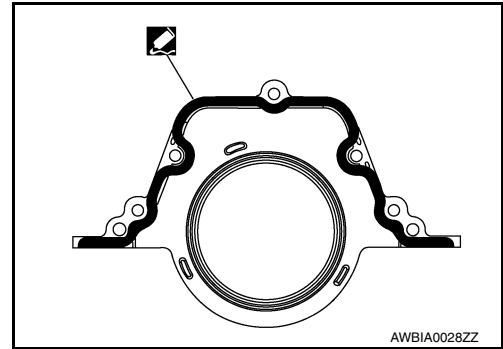

- e. Lubricate the sealing surface of the new rear main seal with new engine oil.
f. Slide the new rear main seal (1) over the Tool (A) and onto the crankshaft.
g. Loosen the wing nut and push the threaded rod into the handle to remove the Tool (A).
h. Tighten the rear oil seal retainer bolts to specification.

Rear oil seal retainer bolts : 8.8 (0.9 kg-m, 78 in-lb)

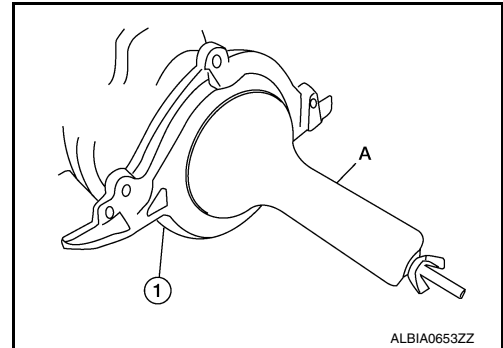

3. Installation of the remaining components is in the reverse order of removal.

CAUTION:

- When replacing an engine or transaxle you must make sure the dowels are installed correctly during re-assembly.
- Improper alignment caused by missing dowels may cause vibration, engine oil leaks or breakage of drivetrain components.

A
EM
C
D
E
F
G
H
I
J
K
L
M
N
O
P

CYLINDER HEAD

< REMOVAL AND INSTALLATION >

CYLINDER HEAD

Exploded View

INFOID:000000011148409

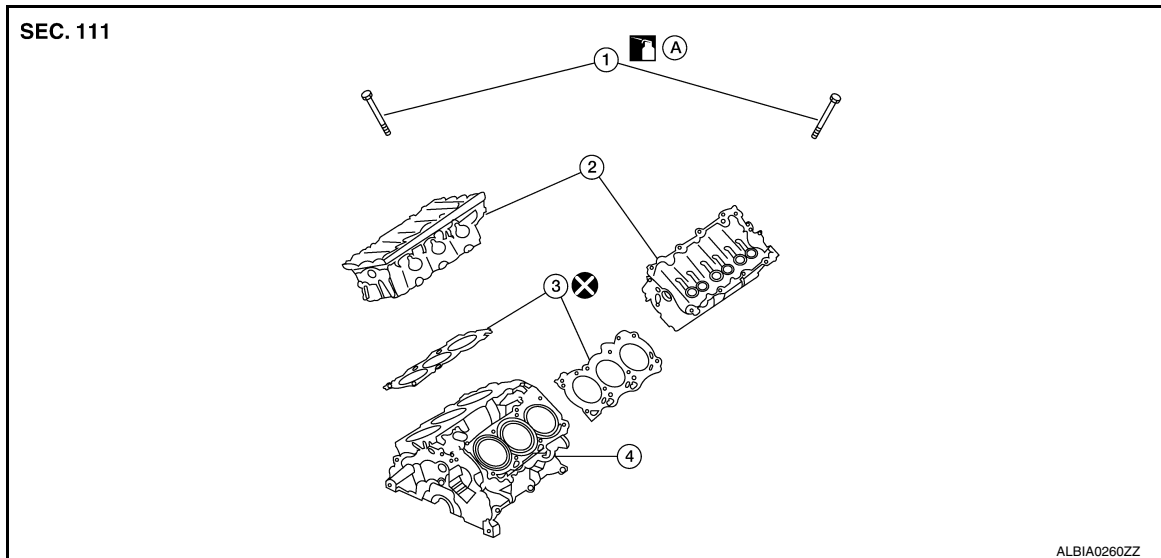

- | | | |
|-----------------------|--------------------------|-------------------------|
| 1. Cylinder head bolt | 2. Cylinder head | 3. Cylinder head gasket |
| 4. Engine block | A. Refer to INSTALLATION | |

Removal and Installation

INFOID:000000011148410

REMOVAL

1. Remove the engine from the vehicle. Refer to [EM-103, "2WD : Removal and Installation"](#) (2WD) or [EM-108, "4WD : Removal and Installation"](#) (4WD).
2. Remove the rear timing chain case. Refer to [EM-71, "Removal and Installation"](#).
3. Remove the intake manifold. Refer to [EM-29, "Removal and Installation"](#).
4. Remove the exhaust manifolds. Refer to [EM-31, "Exploded View"](#).
5. Remove the intake and exhaust camshafts. Refer to [EM-76, "Removal and Installation"](#).
6. Remove the coolant outlet housing. Refer to [CO-26, "Removal and Installation"](#).
7. Remove the (RH) and (LH) cylinder head bolts with power tool.
 - The bolts should be loosened gradually in three stages.
 - Loosen the bolts in the numerical order as shown.

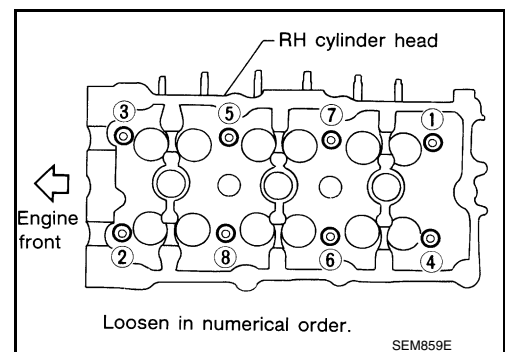

CYLINDER HEAD

< REMOVAL AND INSTALLATION >

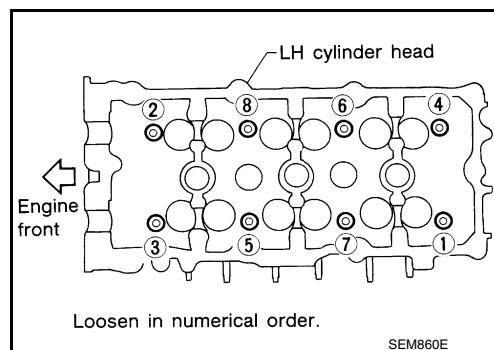

8. Remove cylinder heads and gaskets.
 - Discard the cylinder head gaskets and use new gaskets for installation.

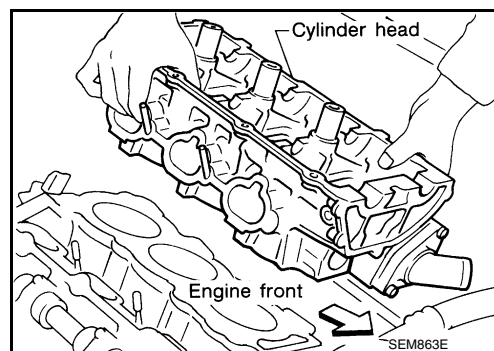

INSTALLATION

1. Turn the crankshaft until No. 1 piston is set at TDC on the compression stroke.
 - The crankshaft key should line up with the RH cylinder center line as shown.

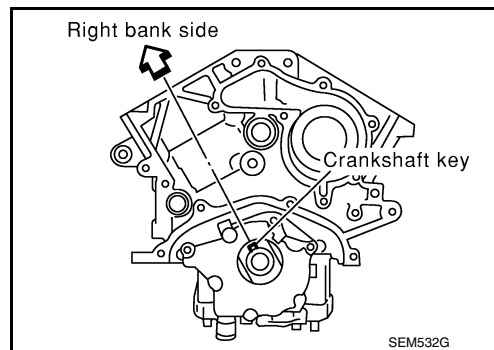

2. Install new cylinder head gaskets.

CAUTION:
Do not reuse cylinder head gaskets.

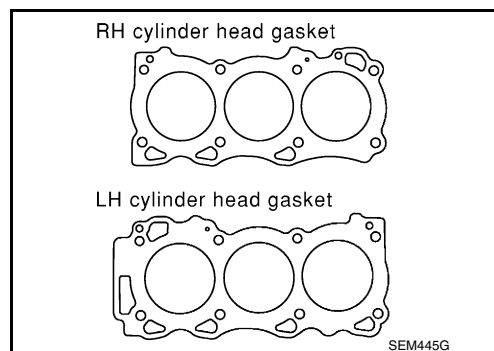

3. Inspect the cylinder head bolts before installing the cylinder heads.

CAUTION:

CYLINDER HEAD

< REMOVAL AND INSTALLATION >

Cylinder head bolts are tightened by degree rotation tightening method. Whenever the size difference between d1 and d2 exceeds the limit, replace the bolts with new ones.

Limit (d1 - d2) : 0.11 mm (0.0043 in)

- Lubricate threads and seat surfaces of the bolts with new engine oil.

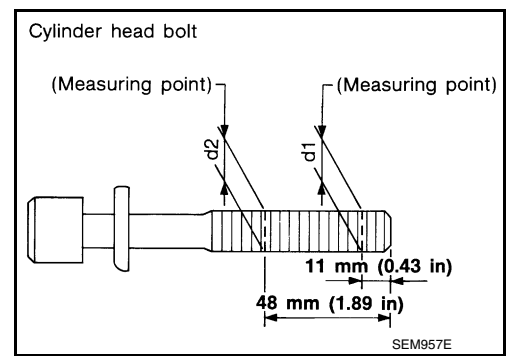

4. Install the cylinder heads on the cylinder block. Tighten the cylinder head bolts in the five steps in the numerical order as shown using Tool.

Tool Number : KV10112100 (BT-8653-A)

- Tightening procedure:

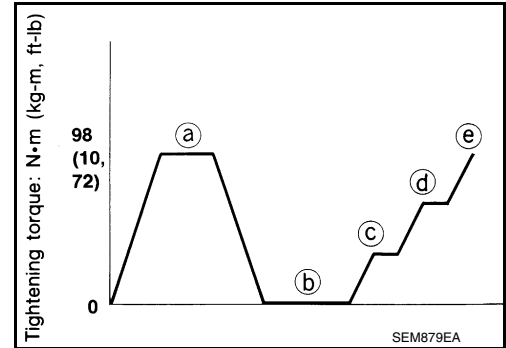

Cylinder head bolts

Step a : 98.1 N·m (10 kg-m, 72 ft-lb) in order

Step b : Loosen in the reverse order of tightening

Step c : 39.2 N·m (4.0 kg-m, 29 ft-lb) in order

Step d : 103° degrees rotation clockwise in order

Step e : 103° degrees rotation clockwise in order

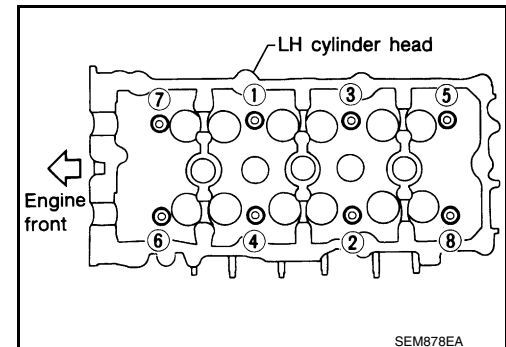
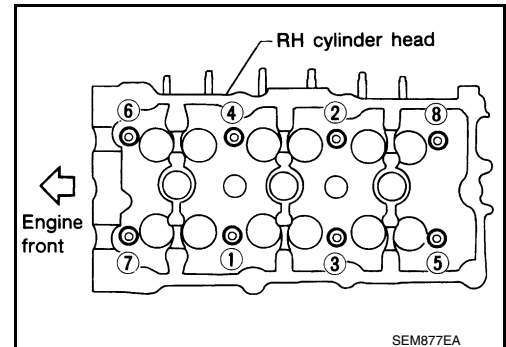

5. Installation of the remaining components is in the reverse order of removal.

CYLINDER HEAD

< REMOVAL AND INSTALLATION >

Disassembly and Assembly

INFOID:000000011148411

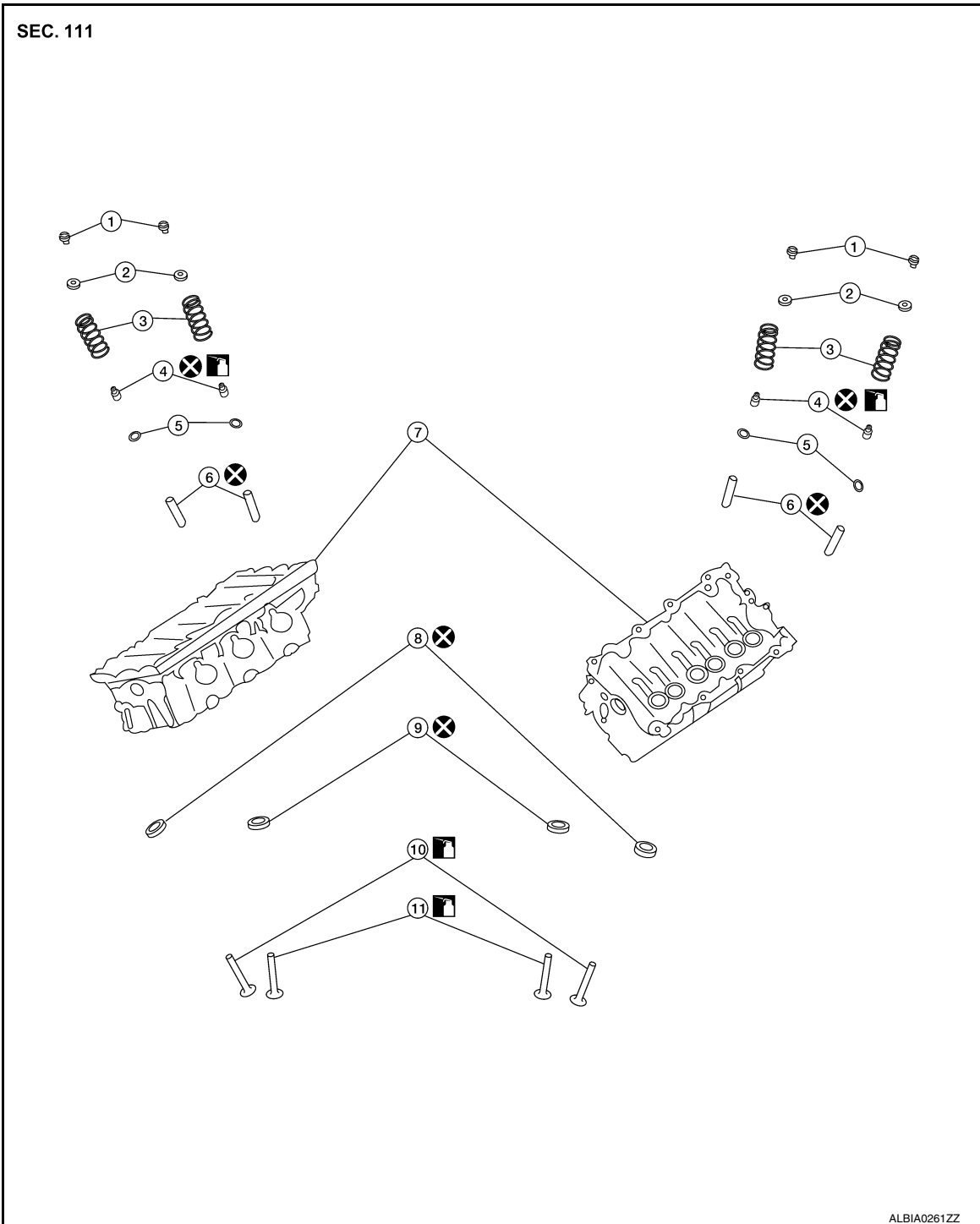

- | | | |
|-------------------|--------------------------|---------------------|
| 1. Valve collet | 2. Valve spring retainer | 3. Valve spring |
| 4. Valve oil seal | 5. Valve spring seat | 6. Valve guide |
| 7. Cylinder head | 8. Valve seat (EXH) | 9. Valve seat (INT) |
| 10. Valve (EXH) | 11. Valve (INT) | |

CAUTION:

- When installing camshafts, chain tensioners, oil seals, or other sliding parts, lubricate contacting surfaces with new engine oil.
- Apply new engine oil to threads and seat surface when installing cylinder head, camshaft sprocket, crankshaft pulley, and camshaft bracket.
- Attach tags to valve lifters so as not to mix them up.

A
EM
C
D
E
F
G
H
I
J
K
L
M
N
O
P

CYLINDER HEAD

< REMOVAL AND INSTALLATION >

DISASSEMBLY

1. Remove spark plug.
2. Remove valve lifter.
 - Identify installation positions and store them without mixing them up.
3. Remove valve collet.
 - Compress valve spring and remove valve collet with magnet hand using Tool.

CAUTION:

When working, take care not to damage valve lifter bore.

Tool numbers : KV10109220 (—)
: KV10116200 (J-26336-A)
: KV10115900 (J-26336-20)

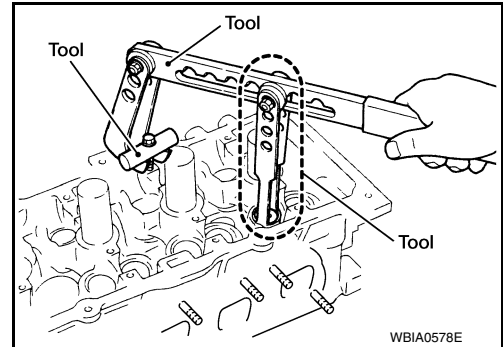

4. Remove valve spring retainer, valve spring and valve spring seat.
5. Push valve stem to combustion chamber side and remove valve.
 - Identify installation positions, and store them without mixing them up.
6. Remove valve oil seals using Tool.

Tool number : KV10107902 (J-38959)

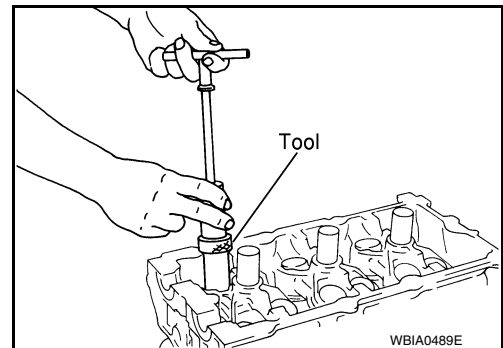

7. If valve seat must be replaced, refer to [EM-95, "Inspection After Disassembly"](#).
 8. If valve guide must be replaced, refer to [EM-95, "Inspection After Disassembly"](#).
 9. Remove spark plug tube, as necessary.
 - Using pair of pliers, pull spark plug tube out of cylinder head.
- CAUTION:**
- **Take care not to damage cylinder head.**
 - **Once removed, spark plug tube will be deformed and cannot be reused. Do not remove it unless absolutely necessary.**

ASSEMBLY

1. When valve guide is removed, install it. Refer to [EM-95, "Inspection After Disassembly"](#).
2. When valve seat is removed, install it. Refer to [EM-95, "Inspection After Disassembly"](#).
3. Install valve oil seals using Tool.

Tool number : KV10115600 (J-38958)

Height (H) (Without valve spring seat installed)

Intake and exhaust : 14.3 - 14.9 mm (0.563 - 0.587 in)

4. Install valve spring seat.
5. Install valves.
 - Install it in the original position.

NOTE:

Larger diameter valves are for intake side.

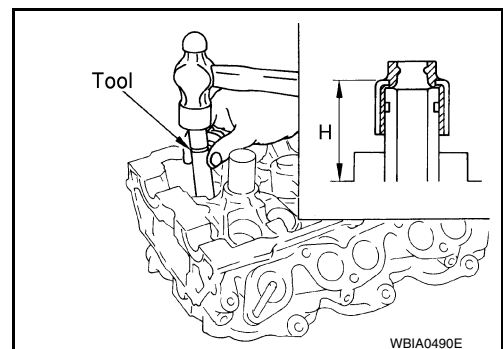

CYLINDER HEAD

< REMOVAL AND INSTALLATION >

6. Install valve spring (uneven pitch type) with narrow pitch end (paint mark) to cylinder head side (valve spring seat side).

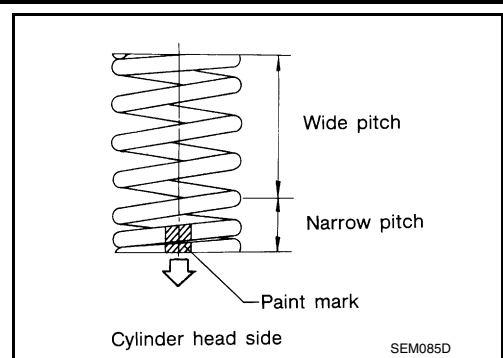

7. Install valve spring retainer.
8. Install valve collet.
• Compress valve spring using Tool, attachment and adapter. Install valve collet with magnet hand.
CAUTION:
When working, take care not to damage valve lifter bore.
• Tap valve stem edge lightly with plastic hammer after installation to check its installed condition.

Tool numbers : KV10109220 (—)
: KV10116200 (J-26336-A)
: KV10115900 (J-26336-20)

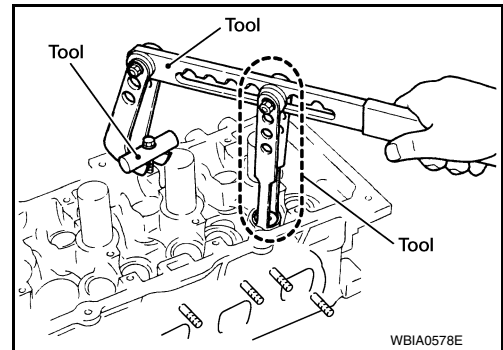

9. Install valve lifter.
• Install it in the original position.
10. Install spark plug tube.
• Press-fit spark plug tube as follows:
a. Remove old liquid gasket adhering to cylinder head mount hole.
b. Apply sealant to area within approximately 12 mm (0.47 in) from edge of spark plug tube press-fit side. **Use Genuine High Strength Locking Sealant or equivalent. Refer to [GI-22, "Recommended Chemical Products and Sealants"](#).**
c. Press-fit spark plug tube so that its height (H) is as specified in using suitable tool.

Press-fit height (H) : 38.2 +0.9/- 0.5 mm (1.5 +0.035 / -0.020 in)

CAUTION:

- **When press-fitting, take care not to deform spark plug tube.**
- **After press-fitting, wipe off liquid gasket protruding onto cylinder-head upper face.**

11. Install spark plug. Refer to [EM-16, "Removal and Installation"](#).

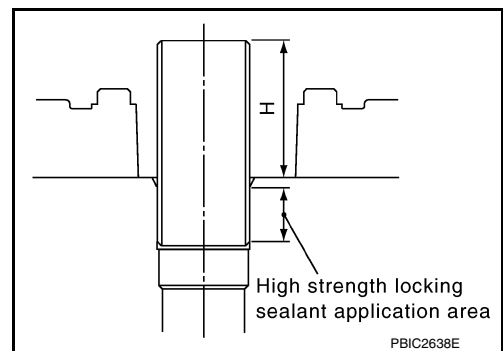

Inspection After Disassembly

INFOID:000000011148412

CYLINDER HEAD DISTORTION

Clean the surface of the cylinder head. Use a reliable straightedge and feeler gauge to check the flatness of cylinder head surface.

CYLINDER HEAD

< REMOVAL AND INSTALLATION >

Check along six positions as shown.

Head surface distortion

| | |
|----------|---------------------------------|
| Limit | : 0.1 mm (0.004 in) |
| Standard | : Less than 0.03 mm (0.0012 in) |

If it exceeds the limit, replace the cylinder head.

The limit for cylinder head resurfacing is determined by the cylinder block resurfacing.

Resurfacing Limit

Amount of cylinder head resurfacing is (A).

Amount of cylinder block resurfacing is (B).

The maximum limit : $A + B = 0.2 \text{ mm (0.008 in)}$

After resurfacing cylinder head, check that camshaft rotates freely by hand. If resistance is felt, cylinder head must be replaced.

Nominal cylinder head height : 126.3 - 126.5 mm (4.972 - 4.980 in)

VALVE GUIDE CLEARANCE

1. Measure valve deflection as shown. (Valve and valve guide mostly wear in this direction.)

Valve deflection limit (dial gauge reading)

| | |
|---------|-----------------------|
| Intake | : 0.24 mm (0.0094 in) |
| Exhaust | : 0.28 mm (0.0110 in) |

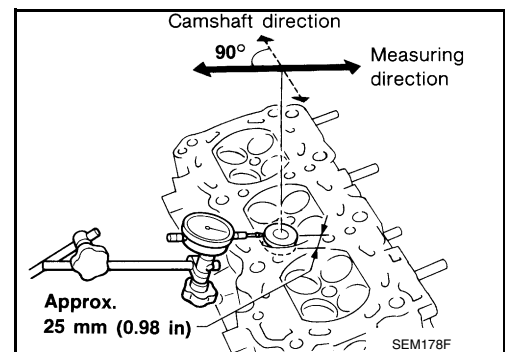

2. If it exceeds the limit, check valve to valve guide clearance.
 - a. Measure valve stem diameter and valve guide inner diameter. Refer to [EM-137, "Cylinder Head"](#).
 - b. Check that clearance is within specification.
(Valve guide clearance) = (Valve guide inner diameter) - (Valve stem diameter)

Valve to valve guide clearance standard

| | |
|---------|---|
| Intake | : 0.020 - 0.053 mm (0.0008 - 0.0021 in) |
| Exhaust | : 0.040 - 0.073 mm (0.0016 - 0.0029 in) |

Valve to valve guide clearance limit

| | |
|---------|-----------------------|
| Intake | : 0.08 mm (0.0031 in) |
| Exhaust | : 0.1 mm (0.004 in) |

- c. If it exceeds the limit, replace valve or valve guide.

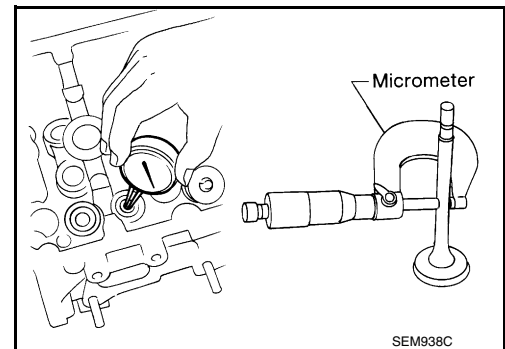

VALVE GUIDE REPLACEMENT

When valve guide is removed, replace with oversized [0.2 mm (0.008 in)] valve guide.

CYLINDER HEAD

< REMOVAL AND INSTALLATION >

1. To remove valve guide, heat cylinder head to 110 - 130°C (230 - 266°F) by soaking in heated oil.

WARNING:

Cylinder head contains heat. When working, wear protective equipment to avoid getting burned.

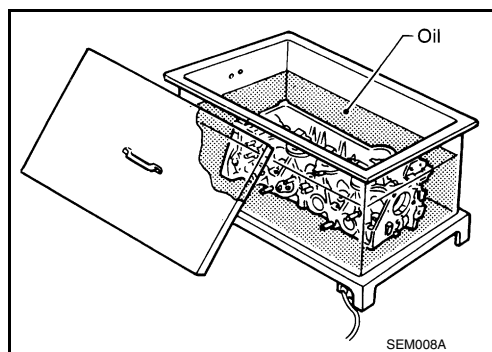

2. Drive out the valve guide with a press [under a 20 kN (2.2 US ton) pressure] or hammer and suitable tool.

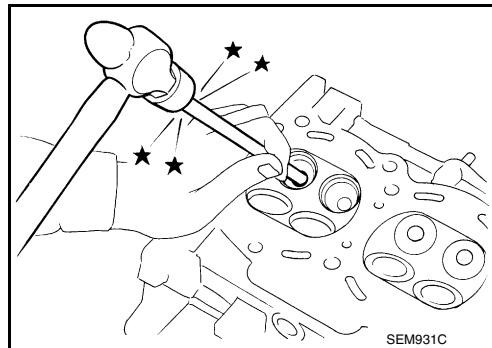

3. Ream cylinder head valve guide hole.

**Valve guide hole diameter : 10.175 - 10.196 mm
(for service parts), intake (0.4006 - 0.4014 in)
and exhaust**

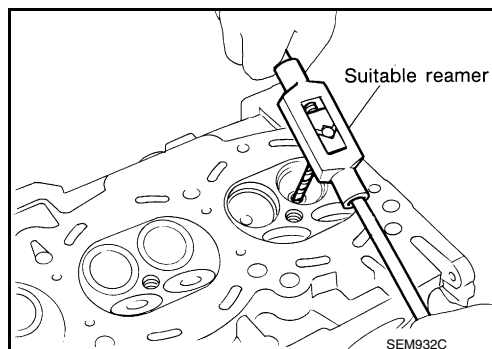

4. Heat cylinder head to 110 - 130°C (230 - 266°F) by soaking in heated oil and press new valve guide from camshaft side into the cylinder head to the dimensions as shown.

Projection (L) : 12.6 - 12.8 mm (0.496 - 0.504 in)

WARNING:

Cylinder head contains heat. When working, wear protective equipment to avoid getting burned.

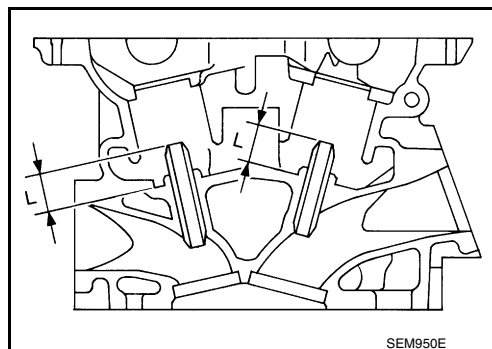

A
EM
C
D
E
F
G
H
I
J
K
L
M
N
O
P

CYLINDER HEAD

< REMOVAL AND INSTALLATION >

- Using a valve guide reamer, apply a reamer finish to the valve guide.

Intake and exhaust : 6.000 - 6.018 mm
finished size (0.2362 - 0.2369 in)

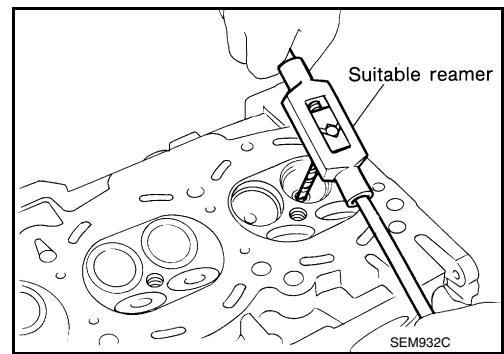

VALVE SEAT CONTACT

- After confirming that the dimensions of valve guides and valves are within specifications, perform this procedure.
- Apply prussian blue onto contacting surface of valve seat to check the condition of the valve contact on the surface.
- Check if the contact area band is continuous all around the circumference.
- If not, grind to adjust valve fitting and check again. If the contacting surface still has NG conditions even after the re-check, replace valve seat.

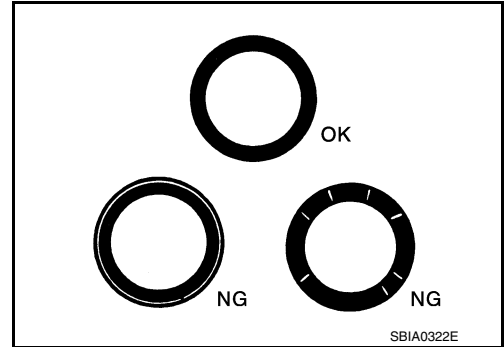

VALVE SEAT REPLACEMENT

- Bore out old seat until it collapses. Boring should not continue beyond the bottom face of the seat recess in cylinder head. Set the machine depth stop to ensure this.
- Ream cylinder head recess for service valve seat.

Oversize : 0.5 mm (0.020 in)
Intake : 38.500 - 38.516 mm
(1.5157 - 1.5164 in)
Exhaust : 32.100 - 32.116 mm
(1.2638 - 1.2644 in)

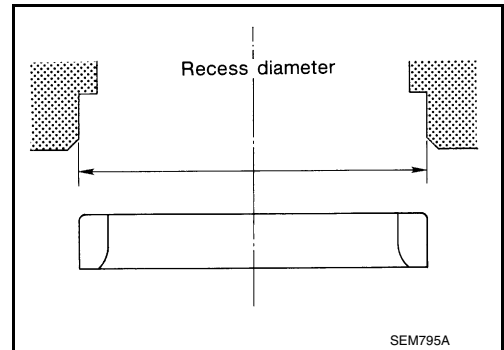

Be sure to ream in circles concentric to the valve guide center.

This will enable valve seat to fit correctly.

- Heat cylinder head to 110 - 130°C (230 - 266°F) by soaking in heated oil.

WARNING:

Cylinder head contains heat. When working, wear protective equipment to avoid getting burned.

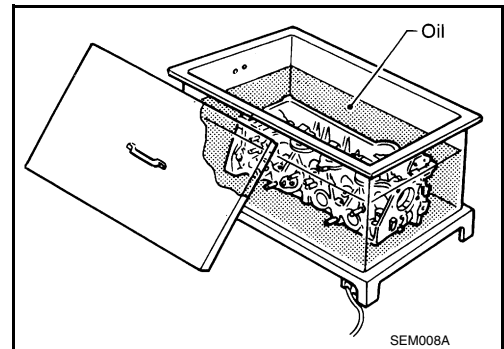

- Press fit valve seat until it seats on the bottom.
- Cut or grind valve seat using suitable tool to the specified dimensions. Refer to [EM-137. "Cylinder Head"](#).
- After cutting, lap valve seat with abrasive compound.
- Check valve seating condition.

CYLINDER HEAD

< REMOVAL AND INSTALLATION >

| | |
|--|--|
| Seat face angle (α) | : 45° 15' - 45° 45' degrees/minutes |
| Contacting width (W) for intake | : 1.18 - 1.22 mm (0.0465 - 0.0480 in) |
| Contacting width (W) for exhaust | : 1.38 - 1.42 mm (0.0543 - 0.0559 in) |

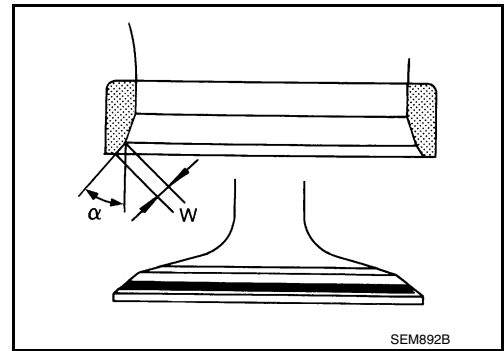

SEM892B

8. Use a depth gauge to measure the distance between the mounting surface of the cylinder head spring seat and the valve stem end. If the distance is shorter than specified, repeat step 5 to adjust it. If it is longer, replace the valve seat with a new one.

| | |
|---|--|
| Valve seat resurface limit (L) intake | : 41.16 - 41.76 mm (1.6205 - 1.6441 in) |
| Valve seat resurface limit (L) exhaust | : 41.09 - 41.69 mm (1.6177 - 1.6413 in) |

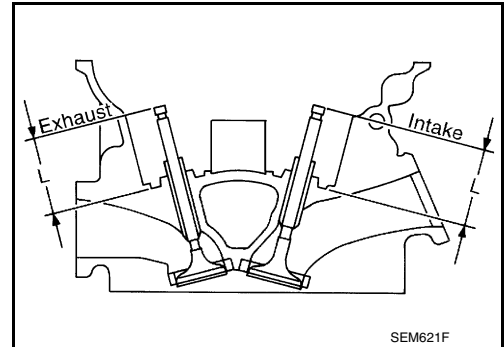

SEM621F

VALVE SPRING SQUARENESS

Set try square along the side of valve spring and rotate the spring. Measure the maximum clearance between the top face of spring and try square.

| | |
|----------------------------|--------------------------------------|
| Out-of-square limit | : Less than 2.0 mm (0.079 in) |
|----------------------------|--------------------------------------|

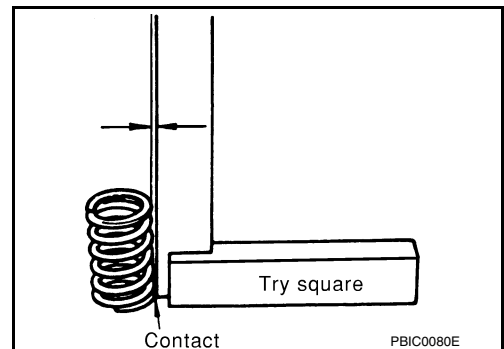

PBIC0080E

VALVE SPRING DIMENSIONS AND VALVE SPRING PRESSURE LOAD

Check valve spring pressure at specified spring height.

| | |
|-----------------|--|
| Standard | : 166 - 188 N (16.9 - 19.2 kg, 37.3 - 42.3 lb) at height 37.0 mm (1.457 in) |
| Limit | : 373 - 421 N (38.0 - 42.9 kg, 84 - 95 lb) at height 27.2 mm (1.071 in) |

If it is not within specifications, replace the spring.

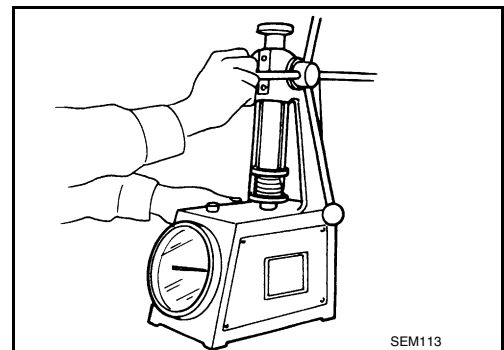

SEM113

ENGINE MOUNT

< REMOVAL AND INSTALLATION >

ENGINE MOUNT

ENGINE MOUNT (FRONT)

ENGINE MOUNT (FRONT) : Removal and Installation

INFOID:000000011148413

WARNING:

- Situate the vehicle on a flat and solid surface.
- Place chocks at front and back of rear wheels.

CAUTION:

- Always work safely.
- Do not start work until the engine and exhaust system are cooled completely.
- Refer to the applicable sections for warnings, cautions, notes, and instructions if necessary procedures are not included in this section.

NOTE:

When removing components such as hoses, tubes/lines, etc., cap or plug openings to prevent fluid from spilling.

REMOVAL

1. Remove the air cleaner case (upper), air cleaner case (lower), front air duct, and air duct hose and resonator assembly. Refer to [EM-24, "Removal and Installation"](#).
2. Remove the battery and battery tray assembly. Refer to [PG-97, "Removal and Installation"](#).
3. Remove the front under cover. Refer to [EXT-30, "Removal and Installation"](#).
4. Remove the fender protector side covers (RH/LH). Refer to [EXT-28, "FENDER PROTECTOR : Exploded View"](#).
5. Partially remove the fender protectors (RH/LH). Refer to [EXT-28, "FENDER PROTECTOR : Removal and Installation"](#).
6. Remove the radiator assembly. Refer to [CO-15, "Removal and Installation"](#).
7. Remove the engine cooling fan shroud and motor assembly. Refer to [CO-17, "Removal and Installation"](#).
8. Remove the exhaust manifold heat shield (LH). Refer to [EM-31, "Exploded View"](#).
9. Support the engine with a suitable tool.
10. Disconnect the engine mount insulator (front) vacuum hose.
11. Remove the engine mount insulator (front) nut (A).

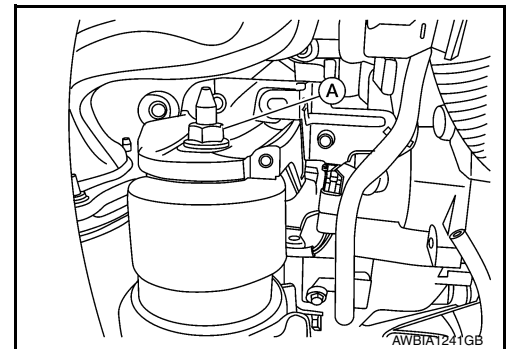

12. Loosen the engine mount bracket (front) bolts in the reverse order shown.

⇐ : Engine front

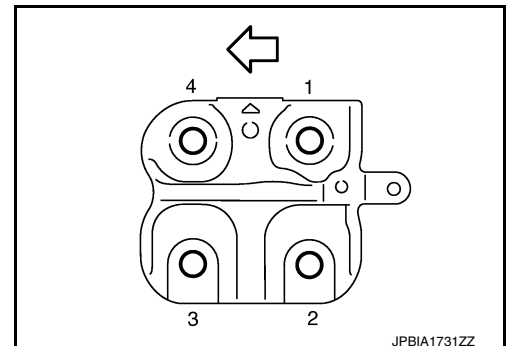

13. Remove the engine mount bracket (front).

ENGINE MOUNT

< REMOVAL AND INSTALLATION >

14. Remove the engine mount insulator (front) bolts in the reverse order as shown.

← : Front

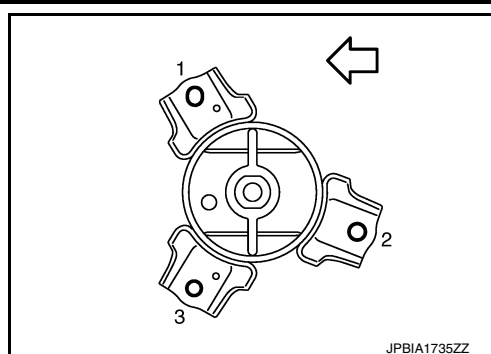

15. Remove the engine mount insulator (front).

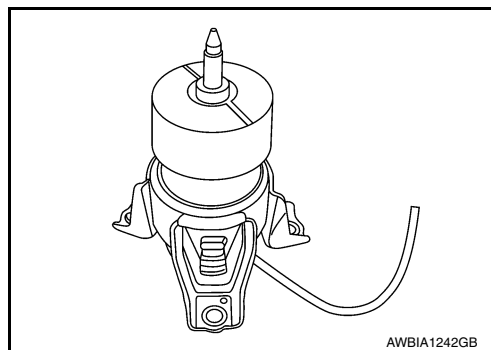

INSTALLATION

CAUTION:

- Do not damage or spill engine oil on the engine mount insulator (front).
- Check engine mount insulator (front) is seated properly before tightening.

1. Install the engine mount insulator (front).

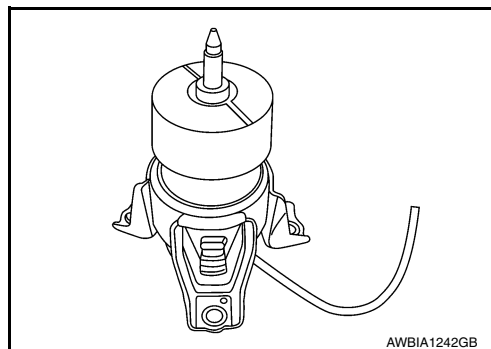

2. Install the engine mount insulator (front) bolts and tighten to specification in the order shown.

← : Front

Engine mount insulator (front) bolts : 55 N·m (5.6 kg-m, 41 ft-lb)

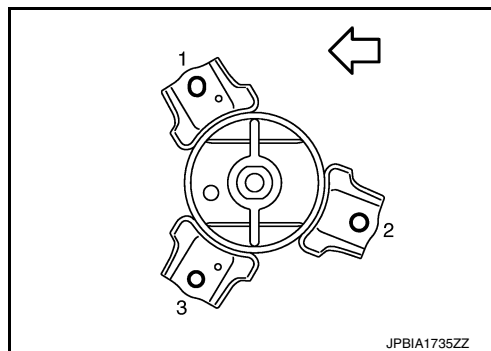

3. Install the engine mount bracket (front) to the engine block.

ENGINE MOUNT

< REMOVAL AND INSTALLATION >

4. Tighten the engine mount bracket (front) bolts to specification in the order shown.

← : Engine front

Engine mount bracket (front) bolts : 40 N·m (4.1 kg-m, 30 ft-lb)

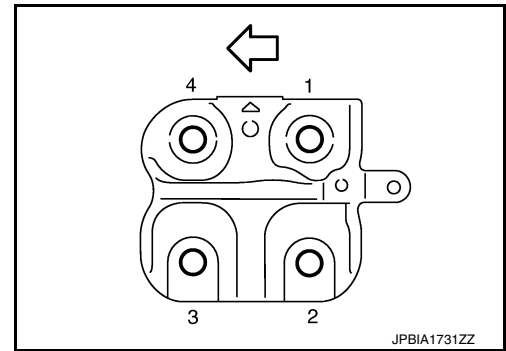

5. Install the engine mount insulator (front) nut (A) and tighten to specification.

Engine mount insulator (front) nut : 103 N·m (11 kg-m, 76 ft-lb)

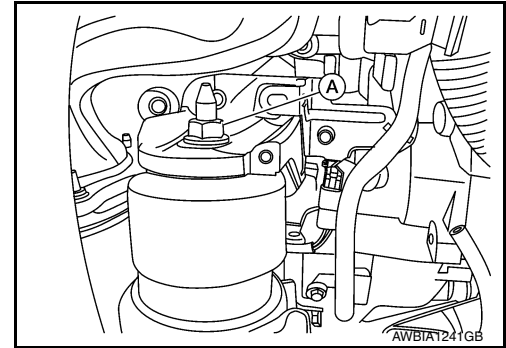

6. Installation of the remaining components is in the reverse order of removal.

ENGINE ASSEMBLY

< UNIT REMOVAL AND INSTALLATION >

UNIT REMOVAL AND INSTALLATION

ENGINE ASSEMBLY

2WD

2WD : Exploded View

INFOID:000000011148414

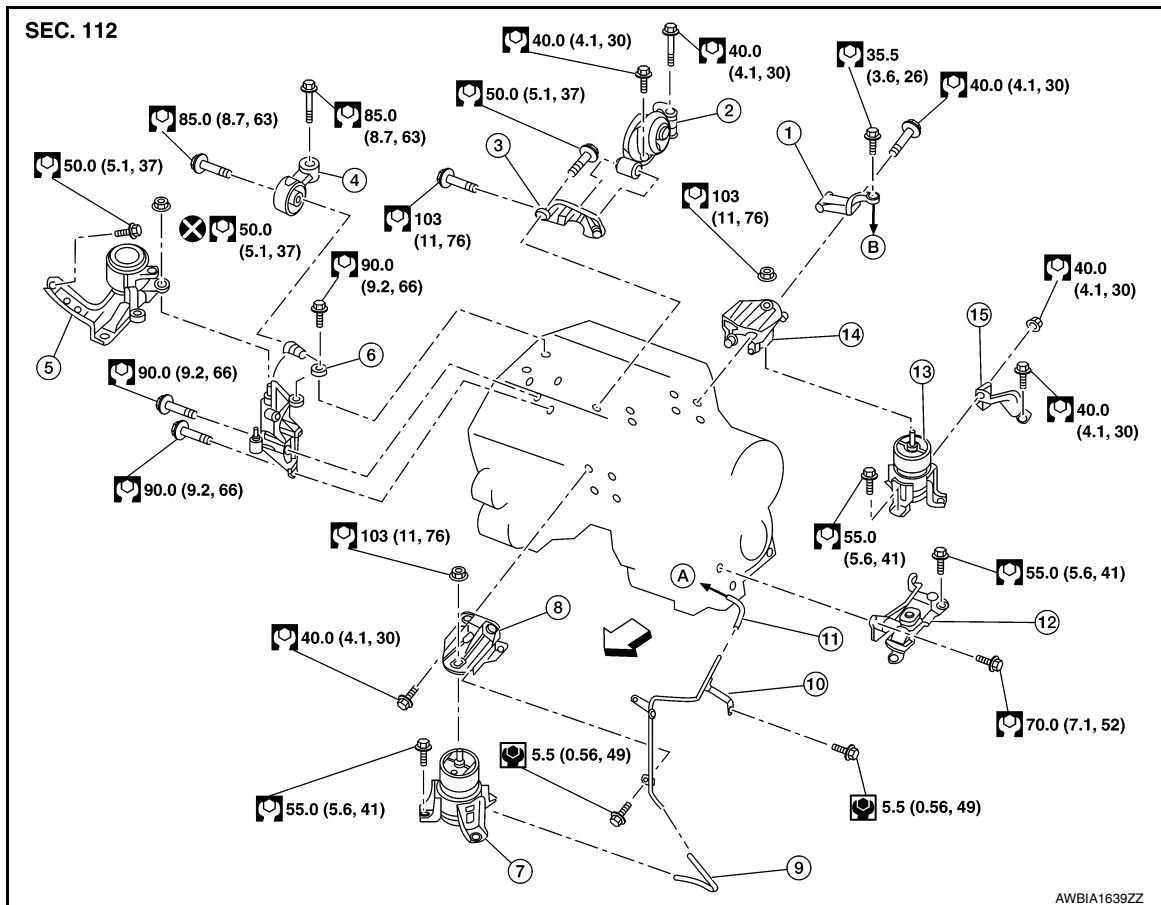

- | | | |
|---|------------------------------------|------------------------------------|
| 1. Gusset | 2. Rear torque rod | 3. Rear torque rod bracket |
| 4. Upper torque rod | 5. Engine mounting insulator (RH) | 6. Engine mounting bracket (RH) |
| 7. Engine mounting insulator (front) | 8. Engine mounting bracket (front) | 9. Vacuum hose |
| 10. Vacuum tube (front) | 11. Vacuum hose | 12. Engine mounting insulator (LH) |
| 13. Engine mounting insulator (rear) | 14. Engine mounting bracket (rear) | 15. Engine mounting stay (rear) |
| A. To electronic controlled engine mount control solenoid valve | B. To transaxle | ⇐ Front |

2WD : Removal and Installation

INFOID:000000011148415

WARNING:

- Situate the vehicle on a flat and solid surface.
- Place chocks at front and back of rear wheels.
- For engines not equipped with engine slingers, attach proper slingers and bolts described in PARTS CATALOG.

CAUTION:

- Always work safely.
- Do not start work until the engine and exhaust system are cooled completely.
- Refer to the applicable sections for warnings, cautions, notes, and instructions if necessary procedures are not included in the engine section.

ENGINE ASSEMBLY

< UNIT REMOVAL AND INSTALLATION >

- For supporting, lifting and jacking points, refer to [GI-35, "2-Pole Lift"](#) and [GI-34, "Garage Jack and Safety Stand"](#).
- Always use the support point specified for lifting.
- Support the vehicle at the rear axle jacking point with transmission jack or similar tool before removing the engine in preparation for the backward shift of the center of gravity.

NOTE:

When removing components such as hoses, tubes/lines, etc., cap or plug openings to prevent fluid from spilling.

REMOVAL

Outline

Remove the engine and transaxle with the front suspension member as a unit. Separate the engine from the transaxle and remove from the front suspension member.

Preparation

1. Release fuel pressure. Refer to [EC-168, "Work Procedure"](#).
2. Drain engine coolant. Refer to [CO-11, "Changing Engine Coolant"](#).
CAUTION:
 - Perform this step when the engine is cold.
 - Do not allow the engine coolant to contact the drive belts.
3. Remove the front under cover. Refer to [EXT-17, "Removal and Installation"](#).
4. Remove the front road wheels and tires using a power tool. Refer to [WT-58, "Adjustment"](#).
5. Remove the fender protector side covers (RH and LH): Refer to [EXT-28, "FENDER PROTECTOR : Removal and Installation"](#).
6. Remove the hood lock switch assembly. Refer to [DLK-301, "HOOD LOCK RELEASE CABLE : Removal and Installation"](#).

Engine Room

1. Remove the air duct (inlet), air cleaner cases (upper and lower) with mass air flow sensor and air duct assembly. Refer to [EM-24, "Removal and Installation"](#).
2. Remove the engine room cover. Refer to [EM-23, "Removal and Installation"](#).
3. Drain the power steering fluid. Refer to [ST-43, "Draining and Refilling"](#).
4. Disconnect engine room harness at the CVT and ECM connectors.
CAUTION:
Protect the harness connector with plastic bags or suitable covering to help prevent damage and intrusion of foreign materials into the connectors.
5. Remove the battery and battery tray. Refer to [PG-95, "Removal and Installation"](#).
6. Remove battery bracket with ECM and CVT module.
7. Disconnect the brake fluid reservoir from the lower cowl panel and position aside.
8. Disconnect the fuse relay box from the lower cowl panel and position aside.
9. Remove the cowl top extension and cowl top. Refer to [EXT-25, "Removal and Installation"](#).
10. Remove the front wiper drive assembly. Refer to [WW-65, "Removal and Installation"](#).
11. Remove the lower cowl panel. Refer to [EXT-25, "Removal and Installation"](#).
12. Disconnect heater hoses. Refer to [HA-44, "HEATER CORE : Removal and Installation"](#).
13. Remove engine cooling fan shroud and motor assembly. Refer to [CO-17, "Removal and Installation"](#).
14. Remove upper and lower radiator hoses. Refer to [CO-15, "Removal and Installation"](#).
15. Remove the radiator. Refer to [CO-15, "Removal and Installation"](#).
16. Remove EVAP hose. Refer to [EC-20, "ENGINE CONTROL SYSTEM : Component Parts Location"](#).
17. Disconnect fuel feed hose quick connector at fuel tube side. Refer to [EM-47, "Exploded View"](#).
18. Disconnect transaxle shift control cable at transaxle side. Refer to [TM-194, "Exploded View"](#).
19. Disconnect brake booster vacuum hose at brake booster. Refer to [BR-31, "Exploded View"](#).
20. Remove harness ground cable.
21. Disconnect low pressure hose from steering pump. Refer to [ST-56, "Removal and Installation"](#).
22. Disconnect high pressure piping from steering pump. Refer to [ST-56, "Removal and Installation"](#).

ENGINE ASSEMBLY

< UNIT REMOVAL AND INSTALLATION >

23. Disconnect the wiring harness from the distribution/fuse block.
24. Disconnect the CVT fluid cooler hoses from the CVT.
25. Remove the upper torque rod.
26. Remove engine mounting insulator (RH) three upper nuts.

Vehicle Underbody

1. Remove exhaust front tube. Refer to [EX-5, "Exploded View"](#).
2. Disconnect steering lower joint at power steering gear assembly and release steering lower shaft. Refer to [ST-58, "Exploded View"](#).
3. Disconnect front stabilizer connecting rod. Refer to [FSU-13, "Exploded View"](#).
4. Remove front brake caliper with piping connected and position them aside. Refer to [BR-36, "BRAKE CAL-IPER ASSEMBLY : Removal and Installation"](#).
5. Remove rear plate cover from oil pan (upper). Then remove nuts attaching the drive plate to the torque converter. Refer to [EM-113, "Disassembly and Assembly"](#).
6. Remove crankshaft position sensor (POS). Refer to [DLN-93, "Exploded View"](#).
CAUTION:
 - Handle carefully to avoid dropping and shocks.
 - Do not disassemble.
 - Do not allow metal powder to adhere to magnetic part at sensor tip.
 - Do not place sensors in a location where they are exposed to magnetism.

Removal

1. Use suitable tool to securely support bottom of front suspension member.

CAUTION:

Put a piece of wood or something similar as the supporting surface to secure a completely stable condition.

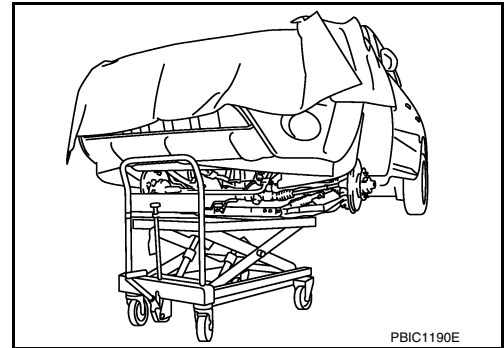

2. Remove front suspension member mounting nuts and bolts. Refer to [FSU-8, "Exploded View"](#).
3. Carefully lower table to remove the engine, the transaxle and the front suspension member. When performing work, observe the following caution:
CAUTION:
 - Confirm there is no interference with the vehicle.
 - Repeatedly check to ensure all harnesses are disconnected before and during engine removal.
 - Check all connection points have been disconnected.
 - Keep in mind the center of vehicle gravity changes. If necessary, use jack(s) to support the vehicle at rear jacking point(s) to prevent it from falling off the lift.

Separation

ENGINE ASSEMBLY

< UNIT REMOVAL AND INSTALLATION >

1. Install engine slingers into front of cylinder head (bank 1) (3) and rear of cylinder head (bank 2) (2).

- (1) : Engine rear slinger
- (4) : Engine front slinger (upper)
- (5) : Engine front slinger (lower)
- ⇐ : Engine front

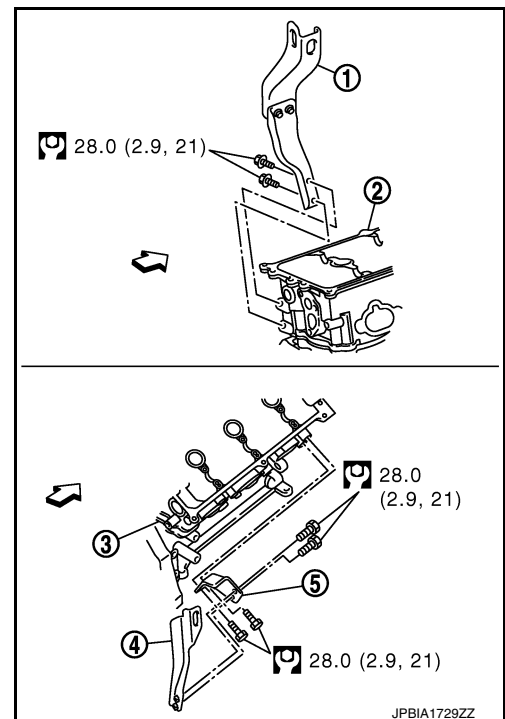

2. Disconnect vacuum hose from front engine mounting insulator.
3. Remove CVT charging pipe. Refer to [TM-217, "Exploded View"](#).
4. Remove starter. Refer to [STR-20, "Removal and Installation"](#).
5. Remove front drive shaft (RH). Refer to [FAX-18, "Removal and Installation \(RH\)"](#).
6. Remove rear torque rod through bolt.
7. Remove engine mounting insulator (rear).
8. Remove transaxle to engine bolts.
9. Separate engine and transaxle assembly.
10. Lift the engine from the front suspension member.

CAUTION:

- Repeatedly check to ensure all harnesses are disconnected before and during engine lifting.
- Avoid spilling engine oil or grease onto the engine mounting insulators to prevent damage to engine mounting insulators.

INSTALLATION

Installation is in the reverse order of removal.

CAUTION:

- Do not damage the engine mounting insulator. Do not spill engine oil on the engine mounting insulator.
- Check all mounting insulators are seated properly, then tighten nuts and bolts.

INSPECTION AFTER INSTALLATION

- Before starting engine, check oil/fluid levels including engine coolant and engine oil. If there is less than required quantity, fill to the specified level. Refer to [MA-15, "FOR USA AND CANADA : Fluids and Lubricants"](#) (United States and Canada) or [MA-17, "FOR MEXICO : Fluids and Lubricants"](#) (Mexico).
- Use procedure below to check for fuel leaks.
- Turn ignition switch ON (with engine stopped). With fuel pressure applied to fuel piping, check for fuel leaks at connection points.
- Start engine. With engine speed increased, check again for fuel leaks at connection points.
- Run engine to check for unusual noise and vibration.

NOTE:

- If hydraulic pressure inside timing chain tensioner drops after removal and installation, slack in the guide may generate a pounding noise during and just after engine start. However, this is normal. Noise will stop after hydraulic pressure rises.
- Warm up engine thoroughly to make sure there are no leaks of fuel, exhaust gas, or any oils/fluids including engine oil and engine coolant.

ENGINE ASSEMBLY

< UNIT REMOVAL AND INSTALLATION >

- Bleed air from passages in lines and hoses, such as in cooling system.
- After cooling down engine, again check oil/fluid levels including engine oil and engine coolant. Refill to specified level, if necessary.
- Summary of the inspection items:

| Item | Before starting engine | Engine running | After engine stopped |
|------------------------|------------------------|----------------|----------------------|
| Engine coolant | Level | Leaks | Level |
| Engine oil | Level | Leaks | Level |
| Transaxle fluid | CVT Models | Leaks | Level/Leaks |
| | | Level/Leaks | Leaks |
| Other oils and fluids* | Level | Leaks | Level |
| Fuel | Leaks | Leaks | Leaks |
| Exhaust gas | — | Leaks | — |

*Power steering fluid, brake fluid, etc.

4WD

4WD : Exploded View

INFOID:000000011148416

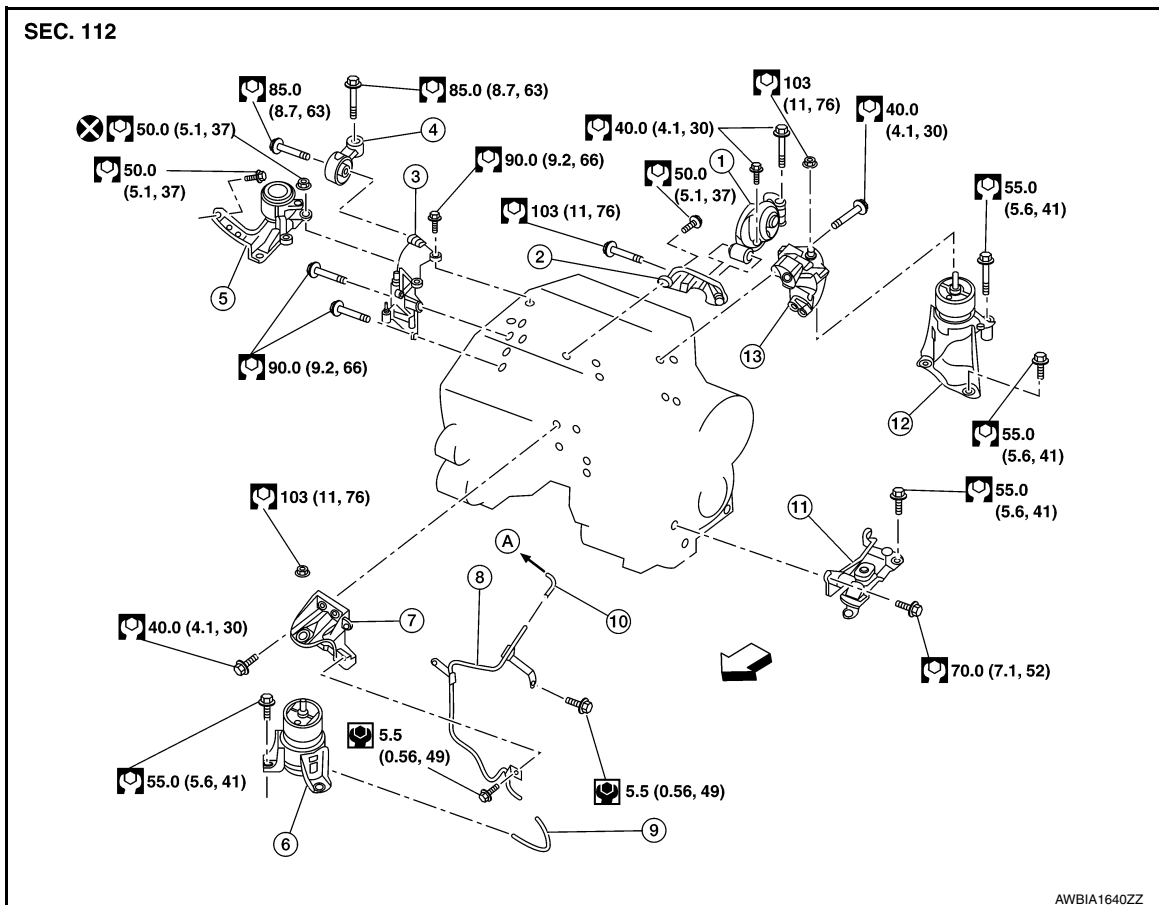

- | | | |
|------------------------------------|---|--------------------------------------|
| 1. Rear torque rod | 2. Rear torque rod bracket | 3. Engine mounting bracket (RH) |
| 4. Upper torque rod | 5. Engine mounting insulator (RH) | 6. Engine mounting insulator (front) |
| 7. Engine mounting bracket (front) | 8. Vacuum tube (front) | 9. Vacuum hose |
| 10. Vacuum hose | 11. Engine mounting insulator (LH) | 12. Engine mounting insulator (rear) |
| 13. Rear engine mount bracket (LH) | A. To electronic controlled engine mount control solenoid valve | ← Front |

ENGINE ASSEMBLY

< UNIT REMOVAL AND INSTALLATION >

4WD : Removal and Installation

INFOID:000000011148417

WARNING:

- Situate the vehicle on a flat and solid surface.
- Place chocks at front and back of rear wheels.
- For engines not equipped with engine slingers, attach proper slingers and bolts described in PARTS CATALOG.

CAUTION:

- Always work safely.
- Do not start work until the engine and exhaust system are cooled completely.
- Refer to the applicable sections for warnings, cautions, notes, and instructions if necessary procedures are not included in the engine section.
- For supporting, lifting and jacking points, refer to [GI-35, "2-Pole Lift"](#) and [GI-34, "Garage Jack and Safety Stand"](#).
- Always use the support point specified for lifting.
- Support the vehicle at the rear axle jacking point with transmission jack or similar tool before removing the engine in preparation for the backward shift of the center of gravity.

NOTE:

When removing components such as hoses, tubes/lines, etc., cap or plug openings to prevent fluid from spilling.

REMOVAL

Outline

Remove the engine, transaxle and transfer assembly with the front suspension member as a unit. Remove the transfer assembly and separate the engine from the transaxle.

Preparation

1. Release fuel pressure. Refer to [EC-168, "Work Procedure"](#).
2. Drain engine coolant. Refer to [CO-11, "Changing Engine Coolant"](#).
CAUTION:
 - Perform this step when the engine is cold.
 - Do not allow the engine coolant to contact the drive belts.
3. Remove the front under cover. Refer to [EXT-17, "Removal and Installation"](#).
4. Remove the front road wheels and tires using a power tool. Refer to [WT-58, "Adjustment"](#).
5. Remove the fender protector side covers (RH and LH): Refer to [EXT-28, "FENDER PROTECTOR : Removal and Installation"](#).
6. Remove the hood lock switch assembly. Refer to [DLK-301, "HOOD LOCK RELEASE CABLE : Removal and Installation"](#).

Engine Room

1. Remove the air duct (inlet), air cleaner cases (upper and lower) with mass air flow sensor and air duct assembly. Refer to [EM-24, "Removal and Installation"](#).
2. Remove the engine room cover. Refer to [EM-23, "Removal and Installation"](#).
3. Drain the power steering fluid. Refer to [ST-43, "Draining and Refilling"](#).
4. Disconnect engine room harness at the CVT and ECM connectors.
CAUTION:
Protect the harness connector with plastic bags or suitable covering to help prevent damage and intrusion of foreign materials into the connectors.
5. Remove the battery and battery tray. Refer to [PG-95, "Removal and Installation"](#).
6. Remove battery bracket with ECM and CVT module.
7. Disconnect the brake fluid reservoir from the lower cowl panel and position aside.
8. Disconnect the fuse relay box from the lower cowl panel and position aside.
9. Remove the cowl top extension and cowl top. Refer to [EXT-25, "Removal and Installation"](#).
10. Remove the front wiper drive assembly. Refer to [WW-65, "Removal and Installation"](#).
11. Remove the lower cowl panel. Refer to [EXT-25, "Removal and Installation"](#).
12. Disconnect heater hoses. Refer to [HA-44, "HEATER CORE : Removal and Installation"](#).

ENGINE ASSEMBLY

< UNIT REMOVAL AND INSTALLATION >

13. Remove engine cooling fan shroud and motor assembly. Refer to [CO-17, "Removal and Installation"](#).
14. Remove upper and lower radiator hoses. Refer to [CO-15, "Removal and Installation"](#).
15. Remove the radiator. Refer to [CO-15, "Removal and Installation"](#).
16. Remove EVAP hose. Refer to [EC-20, "ENGINE CONTROL SYSTEM : Component Parts Location"](#).
17. Disconnect fuel feed hose quick connector at fuel tube side. Refer to [EM-47, "Exploded View"](#).
18. Disconnect transaxle shift control cable at transaxle side. Refer to [TM-194, "Exploded View"](#).
19. Disconnect brake booster vacuum hose at brake booster. Refer to [BR-31, "Exploded View"](#).
20. Remove harness ground cable.
21. Disconnect low pressure hose from steering pump. Refer to [ST-56, "Removal and Installation"](#).
22. Disconnect high pressure piping from steering pump. Refer to [ST-56, "Removal and Installation"](#).
23. Disconnect the wiring harness from the distribution/fuse block.
24. Disconnect the CVT fluid cooler hoses from the CVT.
25. Remove the upper torque rod.
26. Remove engine mounting insulator (RH) three upper nuts.

Vehicle Underbody

1. Remove exhaust front tube. Refer to [EX-5, "Exploded View"](#).
2. Remove heat insulator.
3. Remove rear propeller shaft. Refer to [DLN-102, "Removal and Installation"](#).
4. Disconnect steering lower joint at power steering gear assembly and release steering lower shaft. Refer to [ST-58, "Exploded View"](#).
5. Disconnect front stabilizer connecting rod. Refer to [FSU-13, "Exploded View"](#).
6. Remove front brake caliper with piping connected and position them aside. Refer to [BR-36, "BRAKE CALIPER ASSEMBLY : Removal and Installation"](#).
7. Remove rear plate cover from oil pan (upper). Then remove nuts attaching the drive plate to the torque converter. Refer to [EM-113, "Disassembly and Assembly"](#).
8. Remove crankshaft position sensor (POS). Refer to [DLN-93, "Exploded View"](#).

CAUTION:

- Handle carefully to avoid dropping and shocks.
- Do not disassemble.
- Do not allow metal powder to adhere to magnetic part at sensor tip.
- Do not place sensors in a location where they are exposed to magnetism.

Removal

1. Use suitable tool to securely support bottom of front suspension member.

CAUTION:

Put a piece of wood or something similar as the supporting surface to secure a completely stable condition.

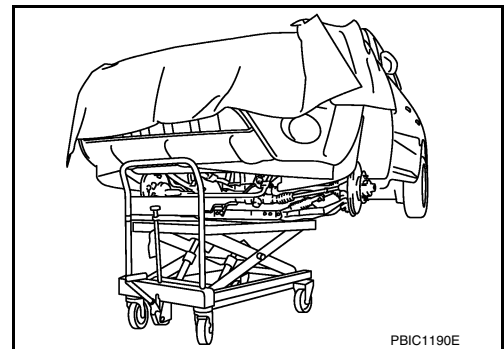

2. Remove front suspension member mounting nuts and bolts. Refer to [FSU-8, "Exploded View"](#).
3. Carefully lower table to remove the engine, the transaxle, transfer assembly and front suspension member. When performing work, observe the following caution:

CAUTION:

- Confirm there is no interference with the vehicle.
- Repeatedly check to ensure all harnesses are disconnected before and during engine removal.
- Check all connection points have been disconnected.
- Keep in mind the center of vehicle gravity changes. If necessary, use jack(s) to support the vehicle at rear jacking point(s) to prevent it from falling off the lift.

ENGINE ASSEMBLY

< UNIT REMOVAL AND INSTALLATION >

Separation

1. Install engine slingers into front of cylinder head (bank 1) (3) and rear of cylinder head (bank 2) (2).

- (1) : Engine rear slinger
- (4) : Engine front slinger (upper)
- (5) : Engine front slinger (lower)
- ⇐ : Engine front

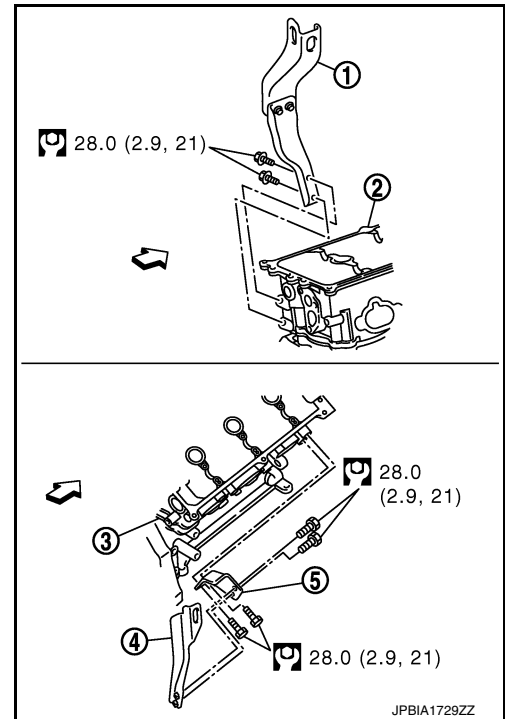

2. Disconnect vacuum hose from front engine mounting insulator.
3. Remove CVT charging pipe. Refer to [TM-217, "Exploded View"](#).
4. Remove starter. Refer to [STR-20, "Removal and Installation"](#).
5. Remove exhaust manifold and three way catalyst (RH). Refer to [EM-31, "Removal and Installation \(bank 2\)"](#).
6. Remove transfer. Refer to [DLN-75, "Removal and Installation"](#).
7. Remove front drive shaft (RH). Refer to [FAX-18, "Removal and Installation \(RH\)"](#).
8. Remove rear torque rod through bolt.
9. Remove engine mounting insulator (rear).
10. Remove transaxle to engine bolts.
11. Separate engine and transaxle assembly.
12. Lift the engine from the front suspension member.

CAUTION:

- Repeatedly check to ensure all harnesses are disconnected before and during engine lifting.
- Avoid spilling engine oil or grease onto the engine mounting insulators to prevent damage to engine mounting insulators.

INSTALLATION

Installation is in the reverse order of removal.

CAUTION:

- Do not damage the engine mounting insulator. Do not spill engine oil on the engine mounting insulator.
- Check all mounting insulators are seated properly, then tighten nuts and bolts.

INSPECTION AFTER INSTALLATION

- Before starting engine, check oil/fluid levels including engine coolant and engine oil. If there is less than required quantity, fill to the specified level. Refer to [MA-15, "FOR USA AND CANADA : Fluids and Lubricants"](#) (United States and Canada) or [MA-17, "FOR MEXICO : Fluids and Lubricants"](#) (Mexico).
- Use procedure below to check for fuel leaks.
- Turn ignition switch ON (with engine stopped). With fuel pressure applied to fuel piping, check for fuel leaks at connection points.
- Start engine. With engine speed increased, check again for fuel leaks at connection points.
- Run engine to check for unusual noise and vibration.

NOTE:

ENGINE ASSEMBLY

< UNIT REMOVAL AND INSTALLATION >

If hydraulic pressure inside timing chain tensioner drops after removal and installation, slack in the guide may generate a pounding noise during and just after engine start. However, this is normal. Noise will stop after hydraulic pressure rises.

- Warm up engine thoroughly to make sure there are no leaks of fuel, exhaust gas, or any oils/fluids including engine oil and engine coolant.
- Bleed air from passages in lines and hoses, such as in cooling system.
- After cooling down engine, again check oil/fluid levels including engine oil and engine coolant. Refill to specified level, if necessary.
- Summary of the inspection items:

| Item | | Before starting engine | Engine running | After engine stopped |
|------------------------|------------|------------------------|----------------|----------------------|
| Engine coolant | | Level | Leaks | Level |
| Engine oil | | Level | Leaks | Level |
| Transaxle fluid | CVT Models | Leaks | Level/Leaks | Leaks |
| | | Level/Leaks | Leaks | Level/Leaks |
| Other oils and fluids* | | Level | Leaks | Level |
| Fuel | | Leaks | Leaks | Leaks |
| Exhaust gas | | — | Leaks | — |

*Power steering fluid, brake fluid, etc.

A
EM
C
D
E
F
G
H
I
J
K
L
M
N
O
P

CYLINDER BLOCK

< UNIT DISASSEMBLY AND ASSEMBLY >

UNIT DISASSEMBLY AND ASSEMBLY

CYLINDER BLOCK

Exploded View

INFOID:000000011148418

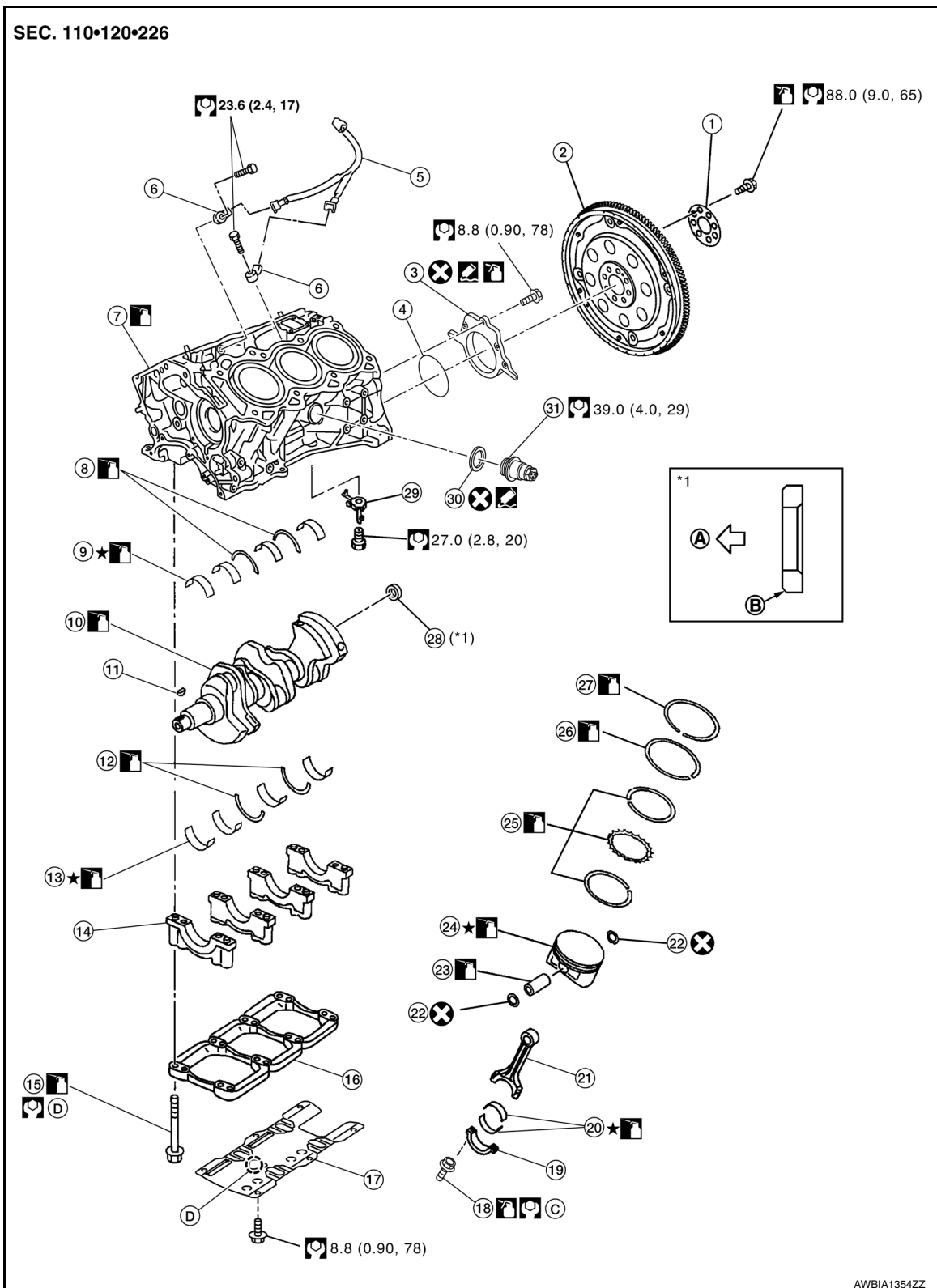

CYLINDER BLOCK

< UNIT DISASSEMBLY AND ASSEMBLY >

- | | | |
|--|----------------------------|----------------------------|
| 1. Reinforcement plate | 2. Drive plate | 3. Rear oil seal retainer |
| 4. Rear oil seal | 5. Sub harness | 6. Knock sensor |
| 7. Cylinder block | 8. Thrust bearing (upper) | 9. Main bearing (upper) |
| 10. Crankshaft | 11. Crankshaft key | 12. Thrust bearing (lower) |
| 13. Main bearing (lower) | 14. Main bearing cap | 15. Main bearing cap bolt |
| 16. Main bearing beam | 17. Baffle plate | 18. Connecting rod bolt |
| 19. Connecting rod bearing cap | 20. Connecting rod bearing | 21. Connecting rod |
| 22. Snap ring | 23. Piston pin | 24. Piston |
| 25. Oil ring | 26. Second ring | 27. Top ring |
| 28. Pilot converter | 29. Oil jet | 30. Gasket (for Canada) |
| 31. Cylinder block heater (for Canada) | A. Crankshaft side | B. Chamfered |
| C. Follow the assembly procedure | D. Front mark | |

A

EM

C

D

E

INFOID:000000011148419

Disassembly and Assembly

CAUTION:

- Apply new engine oil to parts as marked in illustrations before installation.
- Place removed parts such as bearings and bearing caps in their proper order and direction.
- When installing the connecting rod nuts and main bearing cap bolts, apply new engine oil to the threads and mating surfaces
- Do not allow any magnetic materials to contact the signal plate teeth on the drive plate.

F

G

DISASSEMBLY

1. Remove the engine assembly. Refer to [EM-103, "2WD : Removal and Installation"](#) (2WD) or [EM-108, "4WD : Removal and Installation"](#)(4WD).
2. Remove the drive plate. Refer to [EM-132, "Dowel Pin Alignment"](#).
3. Remove pilot converter using Tool.

H

I

Tool number : ST16610001 (J-23907)

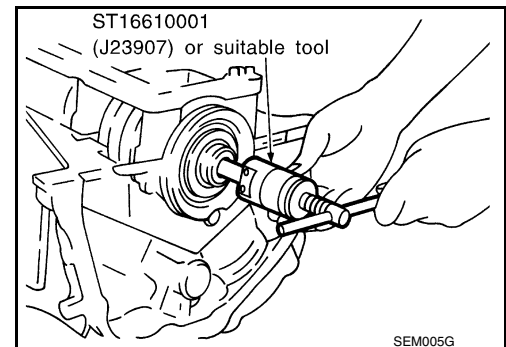

J

K

L

4. Cut away liquid gasket and remove rear oil seal retainer using Tool. Refer to [EM-4, "Precaution for Liquid Gasket"](#).

Tool number : KV10111100 (J-37228)

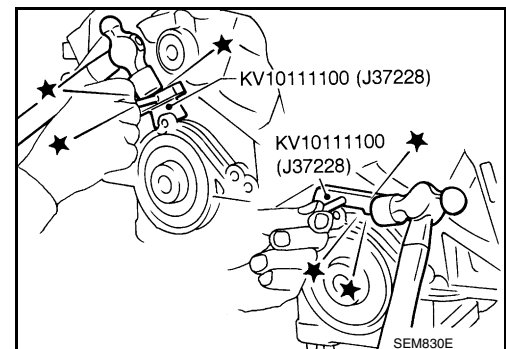

M

N

O

P

CAUTION:

- Be careful not to damage mount surface.
- If rear oil seal retainer is removed, replace it with a new one.

NOTE:

Rear oil seal and retainer form a single part and are replaced as an assembly.

CYLINDER BLOCK

< UNIT DISASSEMBLY AND ASSEMBLY >

5. Install the engine on engine stand. Any commercially available engine stand can be used.

CAUTION:

- Use an engine stand that has a load capacity [approximately 240kg (529 lb) or more] large enough for supporting the engine weight.
- Before removing the hanging chains, make sure the engine stand is stable and there is no risk of overturning.

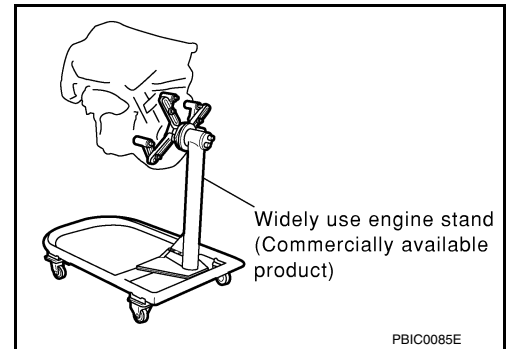

6. Remove the knock sensor.

CAUTION:

Carefully handle sensor to avoid shocking it.

7. Drain the engine of all engine coolant and engine oil.
8. Remove the oil pan. Refer to [EM-37, "Removal and Installation \(Upper Oil Pan\)"](#).
9. Remove the timing chain. Refer to [EM-63, "Removal and Installation"](#).
10. Remove the cylinder head. Refer to [EM-90, "Removal and Installation"](#).

11. Remove the piston and connecting rod assemblies.

- a. Position the crankshaft pin corresponding to the connecting rod to be removed onto the bottom dead center.
b. Remove the connecting rod cap.
c. Using a hammer handle or similar tool, push the piston and connecting rod assembly out to the cylinder head side.
• Before removing the piston and connecting rod assembly, check the connecting rod side clearance. Refer to [EM-145, "Connecting Rod Bearing"](#).

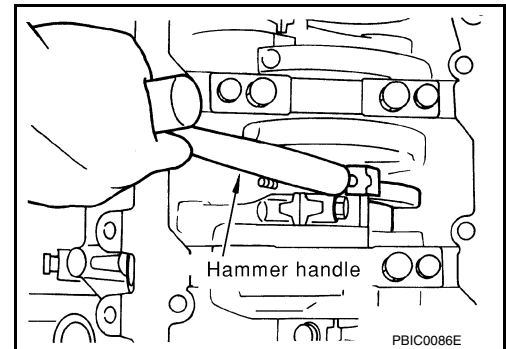

12. Remove the connecting rod bearings.

CAUTION:

- When removing the connecting rod side bearings, note the installation position. Keep them in the correct order.

13. Remove the piston rings from the piston.

- Use a piston ring expander.

CAUTION:

- When removing the piston rings, be careful not to damage the piston. Do not expand the rings excessively.
- Be careful to mark the rings if they are to be reused so they are installed in their original position.

- Before removing the piston rings, check the piston ring side clearance. Refer to [EM-122, "Inspection"](#).

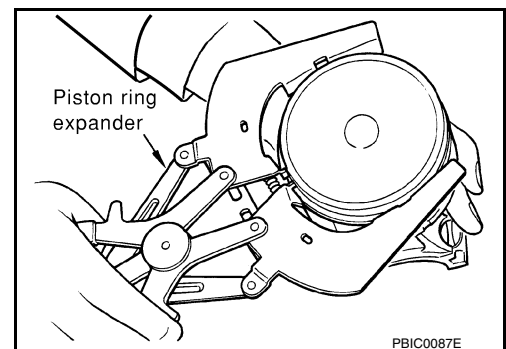

14. Remove the piston from the connecting rod as follows.

- a. Using a snap ring pliers, remove the snap ring.

CAUTION:

Do not reuse snap rings, always replace with new ones.

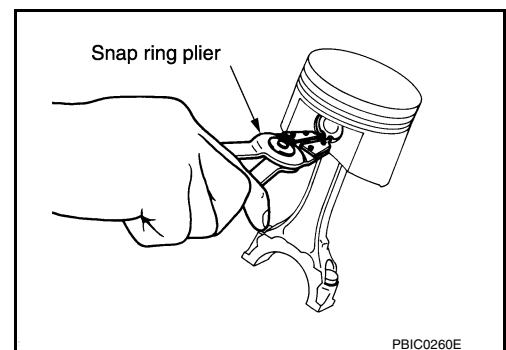

CYLINDER BLOCK

< UNIT DISASSEMBLY AND ASSEMBLY >

- b. Heat the pistons to 60° - 70°C (140° - 158°F).

WARNING:

Pistons contain heat. When working, wear protective equipment to avoid getting burned.

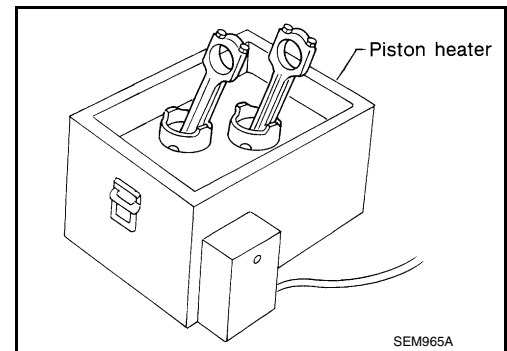

- c. Push out the piston pin with a suitable tool with an outer diameter of approximately 20 mm (0.8 in).

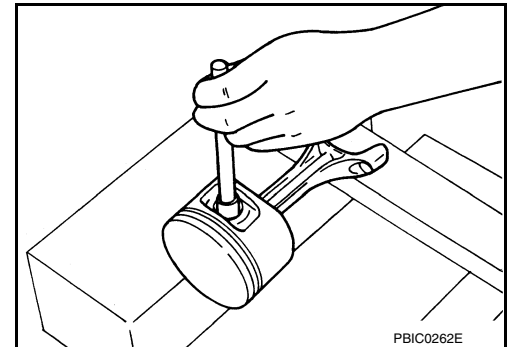

15. Remove the baffle plate from the main bearing beam.
16. Loosen the bolts in the reverse order shown and remove the main bearing beam, bearing caps and crankshaft.
• Before loosening the main bearing cap bolts, measure the crankshaft side clearance.
Refer to [EM-122. "Inspection"](#).

← : Engine front

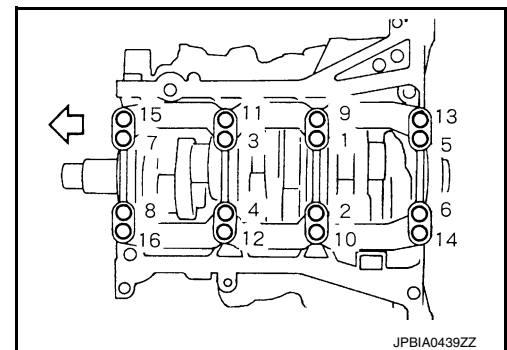

17. Remove the oil jets and dowel pins.
18. Remove the main bearings and thrust bearings from the cylinder block and main bearing caps.
• When removing them, note the direction and position. Keep them in the correct order for installation.

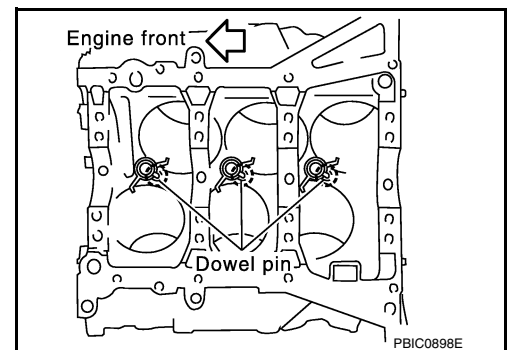

ASSEMBLY

1. Blow out the engine coolant and engine oil passages and cylinder bore to remove any foreign materials.

CAUTION:

Use goggles to protect your eyes.

A
EM
C
D
E
F
G
H
I
J
K
L
M
N
O
P

CYLINDER BLOCK

< UNIT DISASSEMBLY AND ASSEMBLY >

2. Install the cylinder block drain plugs (if removed).
 - Apply sealant to the thread of the water drain plug (B), connector bolt (C) and water drain plug (D), (if removed).

CAUTION:

Do not reuse copper sealing washers.

⇐ : Front

NOTE:

- For Canada, water drain plug (B) is a block heater, not a water drain plug.
- Install copper sealing washers (E) and (A), (if removed).
- Use Genuine High Performance Thread Sealant or equivalent. Refer to [GI-22, "Recommended Chemical Products and Sealants"](#).
- Tighten each plug and connector bolt to specifications.

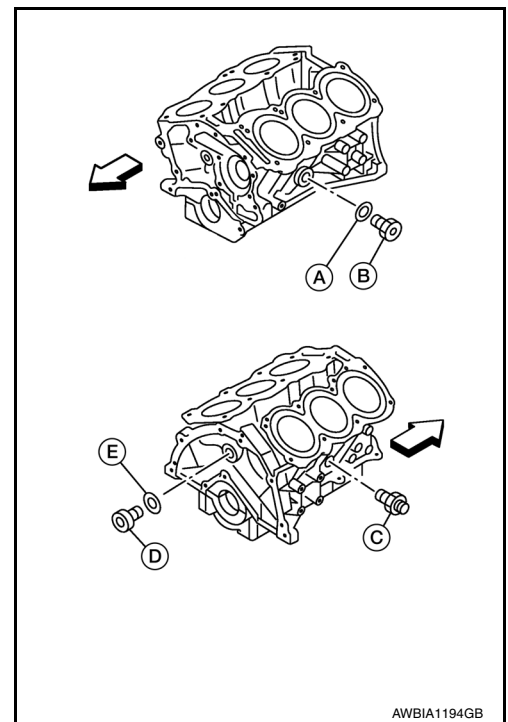

AWBIA1194GB

| Part | Washer | Tightening torque |
|---------------------|--------|-------------------------------|
| (B) (except Canada) | Yes | 62.0 N·m (6.3 kg-m, 46 ft-lb) |
| (B) (for Canada) | Yes | 39.0 N·m (4.0 kg-m, 29 ft-lb) |
| (C) | Yes | 27.0 N·m (2.8 kg-m, 20 ft-lb) |
| (D) | Yes | 78.0 N·m (8.0 kg-m, 58 ft-lb) |

3. Install the oil jets.
 - Insert the oil jet dowel pin into the cylinder block dowel pin hole, and tighten the bolts.

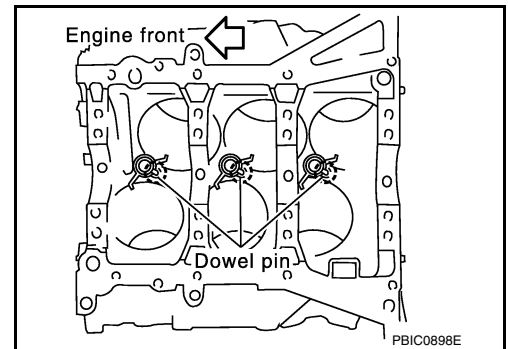

PBIC0898E

4. Install the main bearings and the thrust bearings.
 - a. Remove dust, dirt, and engine oil on the bearing mating surfaces of the cylinder block and the main bearing cap.
 - b. Install the thrust bearings to both sides of the No. 3 journal housing on the cylinder block and the main bearing cap.
 - Install the thrust bearings with the oil groove facing the crankshaft arm (outside).
 - Install bearing with a projection on one end on cylinder block and bearing with a projection at center on cap. Align each projection with mating notch.

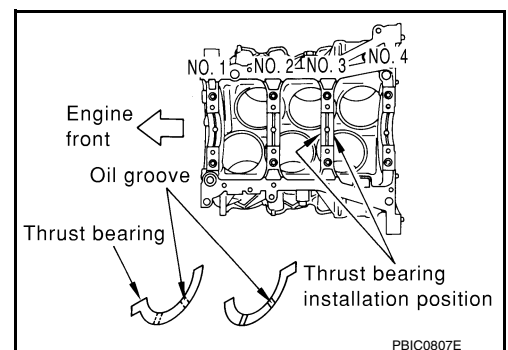

PBIC0807E

CYLINDER BLOCK

< UNIT DISASSEMBLY AND ASSEMBLY >

5. Set the upper main bearings in their proper positions on the cylinder block.
 - Confirm the correct main bearings are used. Refer to [EM-122](#), "[Inspection](#)".

↔ : Engine front

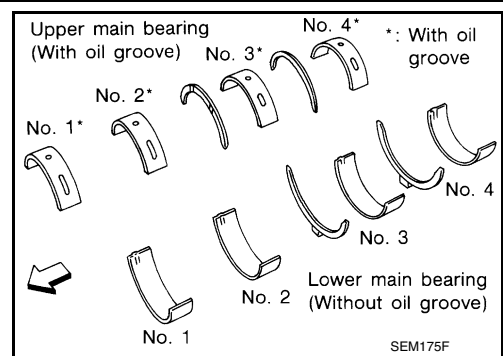

6. Instructions for the re-use of the main bearing cap bolts.
 - A plastic zone tightening method is used for tightening the main bearing cap bolts. Measure (d1) and (d2) as shown.
 - For (d2), select the minimum diameter in the measuring area.
 - If the difference between (d1) and (d2) exceeds the limit, replace the bolts for assembly.

Limit (d1 - d2) : 0.11 mm (0.0043 in)

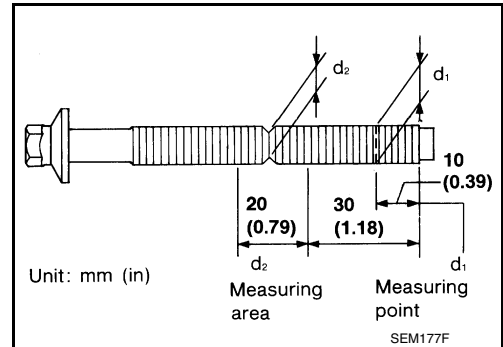

7. After installing the crankshaft, lower main bearings, main bearing caps, main bearing beam, and bearing cap bolts. Tighten the bearing cap bolts in the numerical order as shown.

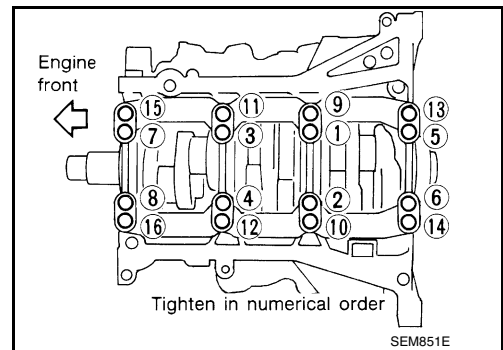

- a. Make sure that the front marks on the main bearing beam faces the front of the engine.
- b. Prior to tightening all the bearing cap bolts, place the bearing beam in its proper position by shifting the crankshaft in the axial position.
- c. After tightening the bearing cap bolts, make sure the crankshaft turns smoothly.
- d. Lubricate the threads and seat surfaces of the bolts with new engine oil.
- e. Tighten the bolts in two stages:

CAUTION:

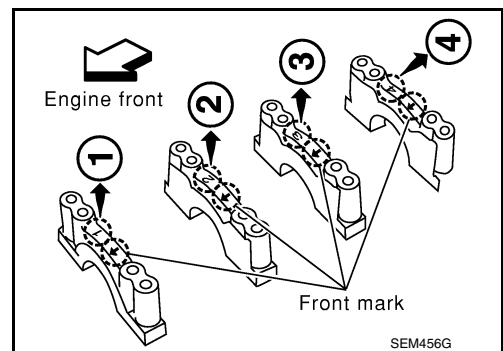

CYLINDER BLOCK

< UNIT DISASSEMBLY AND ASSEMBLY >

Measure the tightening angle using Tool. Do not measure visually.

Stage 1 : 35.3 N·m (3.6 kg-m, 26 ft-lb)

Stage 2 : 90° degrees clockwise

Tool number : KV10112100 (BT-8653-A)

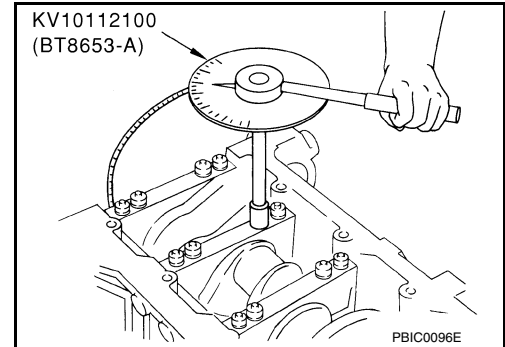

8. Measure crankshaft end play.
• If beyond the limit, replace the thrust bearing with a new one.

Standard : 0.10 - 0.25 mm (0.0039 - 0.0098 in)

Limit : 0.30 mm (0.0118 in)

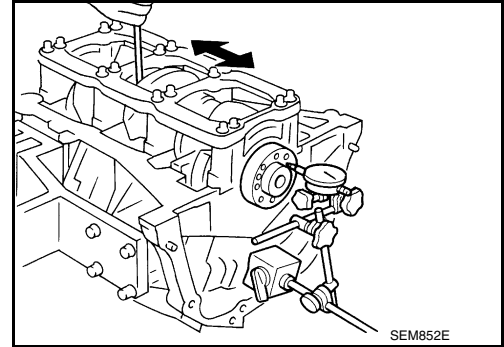

9. Install the piston to the connecting rod.
a. Using suitable snap ring pliers, install the snap ring fully into the pin-groove of the piston rear side.

CAUTION:

Do not reuse snap rings.

- (A) : Piston front mark
(B) : Oil hole
(C) : Connecting rod front mark
(D) : Cylinder No.

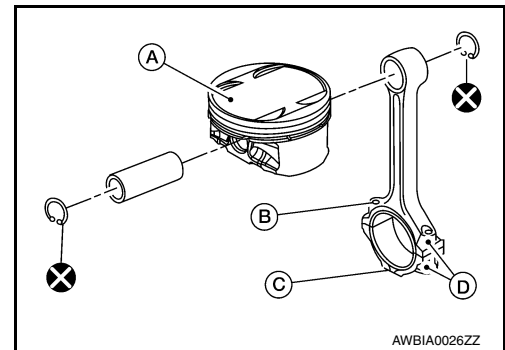

- b. Install the piston to the connecting rod.
• Heat the piston until the piston pin can be pushed in by hand without excessive force [approx. 60 - 70°C (140 - 158°F)]. From the front to the rear, insert the piston pin into the piston and through the connecting rod.

WARNING:

Pistons contain heat. When working, wear protective equipment to avoid getting burned.

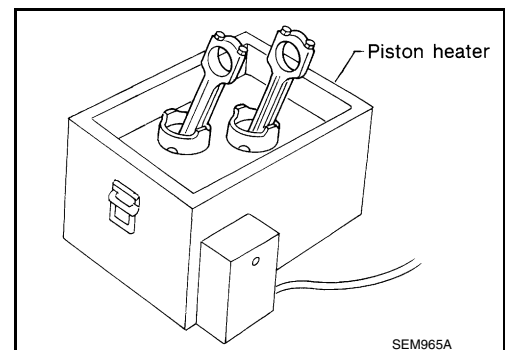

CYLINDER BLOCK

< UNIT DISASSEMBLY AND ASSEMBLY >

- Assemble so that the piston front mark (B) on the crown and the oil hole (C), connecting rod front mark (D) and Cylinder No. (E) on the connecting rod are positioned as shown.

← : Engine front

(A) : Piston grade number

(F) : Pin grade number

(G) : Crown I.D. code

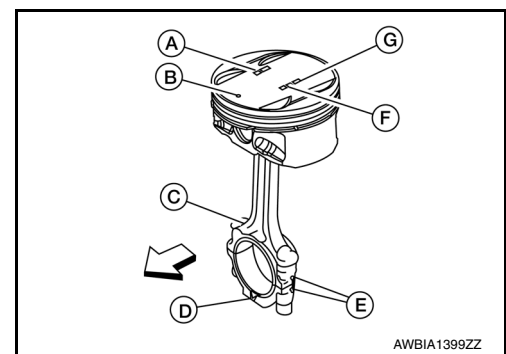

- c. Install the snap ring into the front of the piston pin-groove.
- After installing, check that the connecting rod pivots smoothly on the pin.

CAUTION:

Do not reuse snap rings.

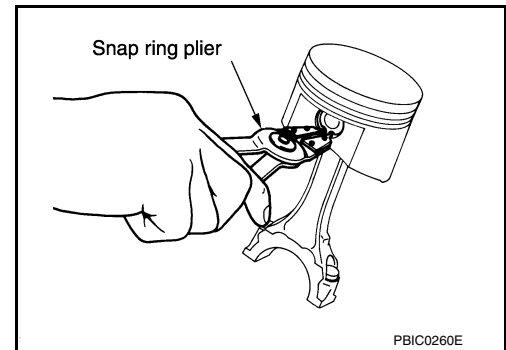

10. Using a piston ring expander, install the piston rings.

(A) : Top ring

(B) : Second ring

CAUTION:

- Be careful not to damage the piston.
- When the piston rings are not replaced, remount the rings in their original positions.
- When replacing the piston rings, those without stamped surface (A) can be mounted either side up.
- Install the second ring with the stamped surface (B) facing upward. If the ring is not stamped it can face in either direction.

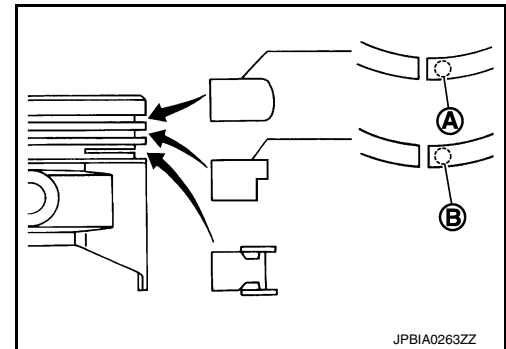

- Position each ring with the gap as shown, referring to the piston front mark.

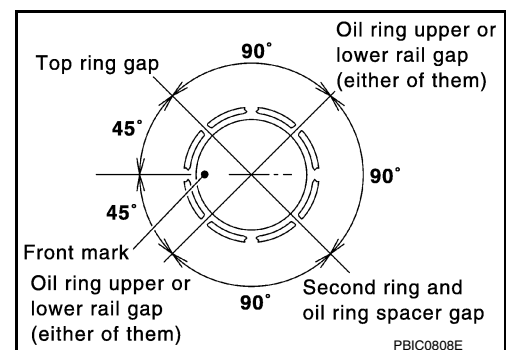

CYLINDER BLOCK

< UNIT DISASSEMBLY AND ASSEMBLY >

11. Install the connecting rod bearings to the connecting rod and the connecting rod cap.
- When installing the connecting rod bearings, apply engine oil to the bearing surface (crankshaft side). Do not apply engine oil to the back surface (connecting rod and cap side), but thoroughly clean it.
 - When installing, align the connecting rod bearing protrusion with the notch of the connecting rod to install.
 - Check that the oil holes on the connecting rod and on the corresponding bearing are aligned.

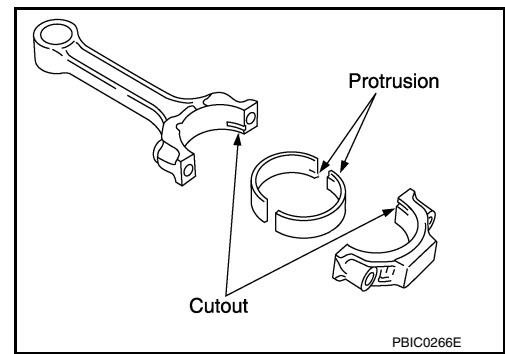

12. Install the piston and connecting rod assembly into the corresponding cylinder.
- Position the crankshaft pin corresponding to the connecting rod to be installed onto the bottom dead center.
 - Apply engine oil sufficiently to the cylinder bore, piston, and crankshaft pin.
 - Match the cylinder position with the cylinder No. (B) on the connecting rod to install.
 - Install the piston with the piston front mark (A) on the crown facing the front of the engine (↔) using Tool.

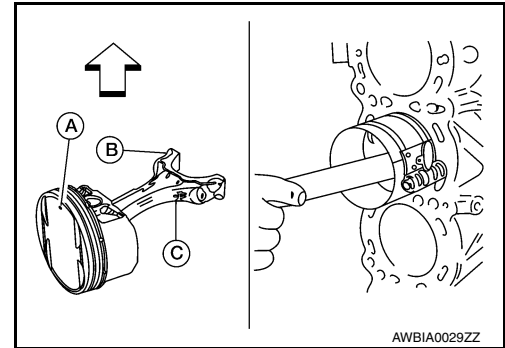

(C) : Oil hole

Tool number : EM03470000 (J-8037)

CAUTION:

Be careful not to damage the crankshaft pin and cylinder wall, resulting from interference of the connecting rod big end.

13. Install the connecting rod cap.
- Match the stamped cylinder number marks on the connecting rod with those on the cylinder cap for installation.
 - Install the piston connecting rod assembly and cap so that the front mark on the cap and piston are facing the front of the engine.
 - **Lubricate the threads and seat surfaces with new engine oil.**

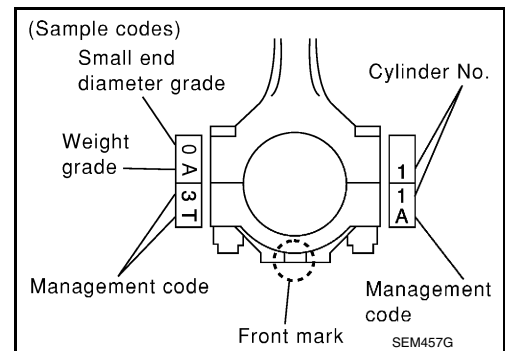

14. Check the connecting rod cap bolts before reusing, then install in their original position in the connecting rod. The bolts should screw in smoothly by hand.
- Measure the outer diameter of the connecting rod cap bolt as shown.

Outer diameter (d) of the connecting rod bolt

Standard : 7.90 - 8.00 mm (0.3110 - 0.3150 in)

Limit : 7.75 mm (0.3051 in)

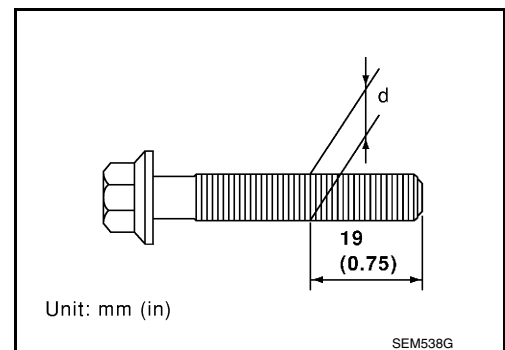

Unit: mm (in)

15. Tighten the connecting rod nuts in two stages using Tool:

CYLINDER BLOCK

< UNIT DISASSEMBLY AND ASSEMBLY >

Stage 1 : 19 - 21 N·m (1.9 - 2.1 kg-m, 14 - 15 ft-lb)

Stage 2 : 90° - 95° degrees clockwise

CAUTION:

Measure the tightening angle using Tool. Do not measure visually.

Tool number : KV10112100 (BT-8653-A)

- Apply engine oil to the threads and seats of the connecting rod bolts and nuts.
- After tightening the nuts, make sure that the crankshaft rotates smoothly.
- Check the connecting rod side clearance. If beyond the limit, replace the connecting rod and/or crankshaft.

Connecting rod side clearance:

Standard : 0.20 - 0.35 mm (0.0079 - 0.0138 in)

Limit : 0.40 mm (0.0157 in)

16. Install the baffle plate to the main bearing beam.

17. Install the knock sensor.

- Make sure that there is no foreign material on the cylinder block mating surface and the back surface of the knock sensor.
- Install the knock sensor with the connector facing the rear of the engine.
- Do not tighten the bolts while holding the connector.
- Make sure that the knock sensor does not interfere with other parts.

CAUTION:

If any impact by dropping occurs to the knock sensor, replace it with new one.

18. Install the cylinder head. Refer to [EM-90, "Removal and Installation"](#).

19. Install the timing chain. Refer to [EM-63, "Removal and Installation"](#).

20. Install the oil pan. Refer to [EM-37, "Removal and Installation \(Upper Oil Pan\)"](#).

21. Remove engine from the stand.

22. Install the pilot converter with its chamfer facing crankshaft as shown.

← : Crankshaft side

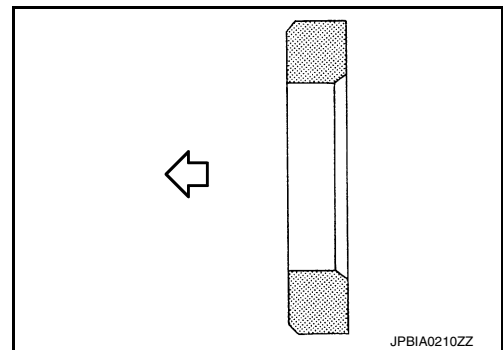
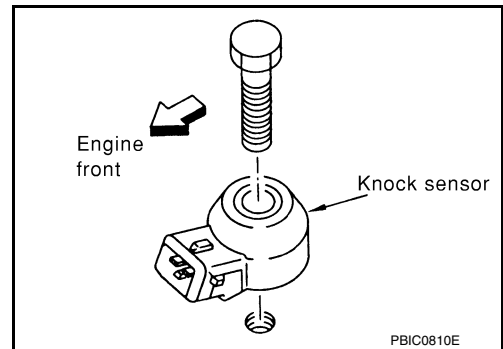
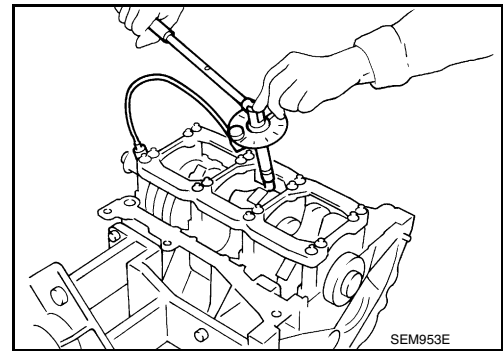

A
EM
C
D
E
F
G
H
I
J
K
L
M
N
O
P

CYLINDER BLOCK

< UNIT DISASSEMBLY AND ASSEMBLY >

23. Install the rear oil seal retainer using Tool (A).

Tool number (A) : — (J-47128)

- Loosen the wing nut (B) on the end of the Tool (A).
- Insert the arbor (D) into the crankshaft pilot hole until the outer lip (C) of the Tool (A) covers the edge of the crankshaft sealing surface.
- Tighten the wing nut (B) to secure the Tool (A) to the crankshaft.

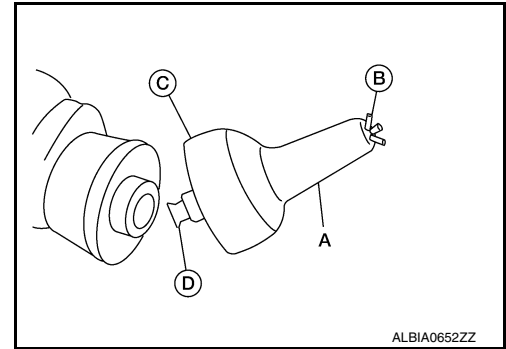

- Apply sealant to rear oil seal retainer as shown. Use **Genuine Silicone RTV Sealant, or equivalent**. Refer to [GI-22, "Recommended Chemical Products and Sealants"](#).

CAUTION:

- Installation should be done within 5 minutes after applying liquid gasket.
- Do not fill the engine with engine oil for at least 30 minutes after the components are installed to allow the sealant to cure.

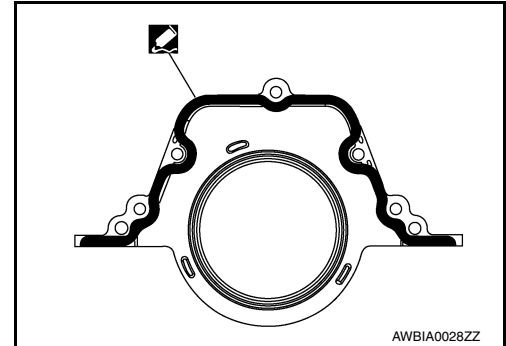

- Lubricate the sealing surface of the new rear main seal with new engine oil.
- Slide the new rear main seal (1) over the Tool (A) and onto the crankshaft.
- Loosen the wing nut and push the threaded rod into the handle to remove the Tool (A).
- Tighten the rear oil seal retainer bolts to specification. Refer to [EM-88, "Removal and Installation of Rear Oil Seal"](#).

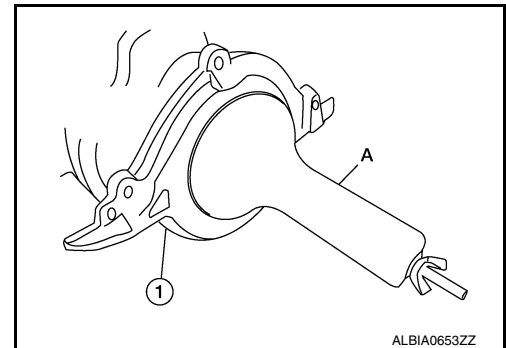

24. Install the drive plate. Refer to [EM-132, "Dowel Pin Alignment"](#).

25. Install the engine assembly into the vehicle. Refer to [EM-103, "2WD : Removal and Installation"](#) (2WD) or [EM-108, "4WD : Removal and Installation"](#) (4WD).

Inspection

INFOID:000000011148420

PISTON AND PISTON PIN CLEARANCE

Inner Diameter of Piston Pin Hole

- Measure the inner diameter of piston pin hole (dp).

Standard diameter (dp)

Grade No. 0 : 21.993 – 21.999 mm (0.8659 – 0.8661 in)

Grade No. 1 : 21.999 – 22.005 mm (0.8661 – 0.8663 in)

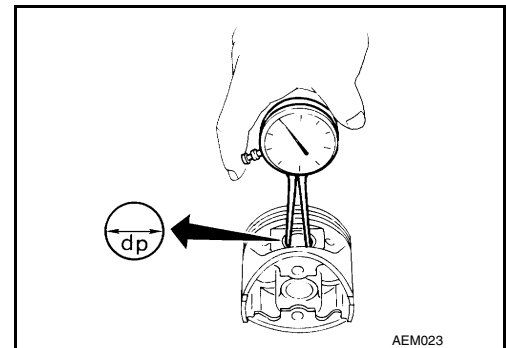

Outer Diameter of Piston Pin

CYLINDER BLOCK

< UNIT DISASSEMBLY AND ASSEMBLY >

- Measure outer diameter of piston pin (Dp).

Standard diameter (Dp)

Grade No. 0 : 21.989 – 21.995 mm (0.8657 – 0.8659 in)

Grade No. 1 : 21.995 – 22.001 mm (0.8659 – 0.8662 in)

- ← : Engine front
- (A) : Piston grade No.
- (B) : Piston front mark
- (C) : Oil hole
- (D) : Connecting rod front mark
- (E) : Cylinder No.
- (F) : Pin grade No.
- (G) : Crown I.D. code

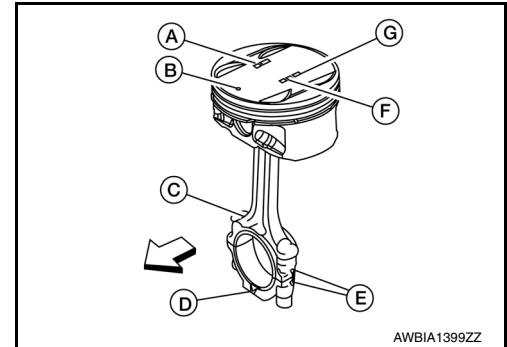
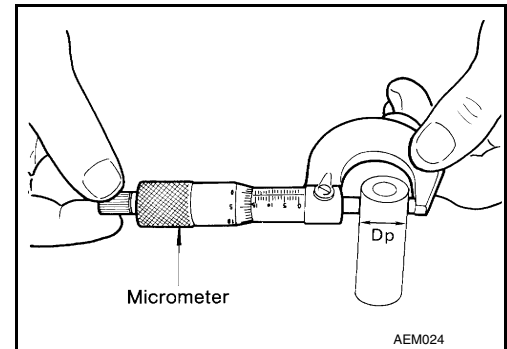

Piston and Piston Pin Interference Fit
Standard Interference Fit = (Dp) – (dp)

Standard : 0.002 – 0.010 mm (0.0001 – 0.0004 in)

- If clearance exceeds specification, replace either or both of piston/piston pin assembly and connecting rod assembly with reference to specification of each part.

PISTON RING SIDE CLEARANCE

- Measure side clearance of piston ring and piston ring groove with feeler gauge.

Standard Side Clearance

Top ring : 0.045 - 0.080 mm (0.0018 - 0.0031 in)

2nd ring : 0.030 - 0.070 mm (0.0012 - 0.0028 in)

Oil ring : 0.045 - 0.125 mm (0.0018 - 0.0049 in)

Maximum Limit

Top ring : 0.11 mm (0.0043 in)

2nd ring : 0.1 mm (0.004 in)

Oil ring : —

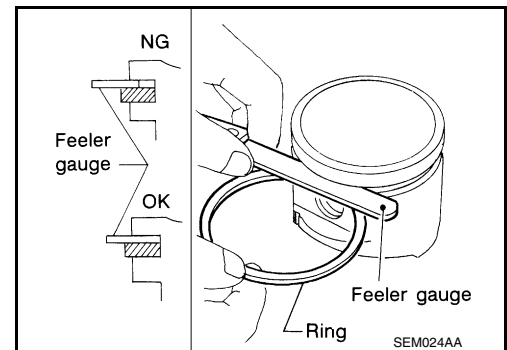

- If out of specification, replace piston ring assembly. If clearance exceeds maximum limit with new rings, replace piston.

PISTON RING END GAP

CYLINDER BLOCK

< UNIT DISASSEMBLY AND ASSEMBLY >

- Insert piston ring until it is in the middle of the cylinder bore and measure the end gap.

Standard

Top ring : 0.23 - 0.28 mm (0.0091 - 0.0110 in)
2nd ring : 0.33 - 0.43 mm (0.0130 - 0.0169 in)
Oil ring : 0.20 - 0.45 mm (0.0079 - 0.0177 in)

Limit:

Top ring : 0.50 mm (0.0197 in)
2nd ring : 0.62 mm (0.0244 in)
Oil ring : 0.80 mm (0.0315 in)

- If out of specification, replace piston ring.

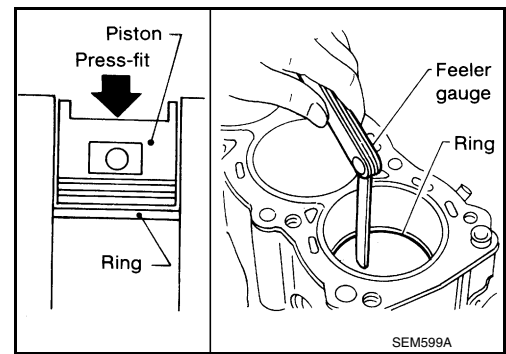

CONNECTING ROD BEND AND TORSION

Bend : Limit 0.15 mm (0.0059 in) per 100 mm (3.94 in) length
Torsion : Limit 0.30 mm (0.0118 in) per 100 mm (3.94 in) length

- If it exceeds the limit, replace connecting rod assembly.

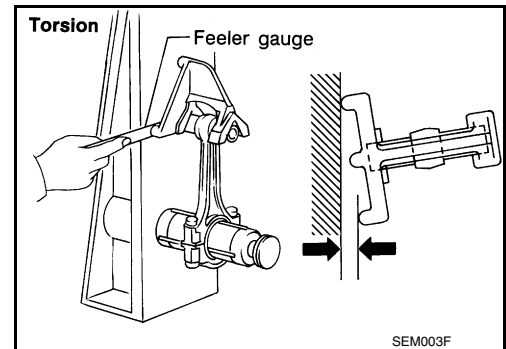
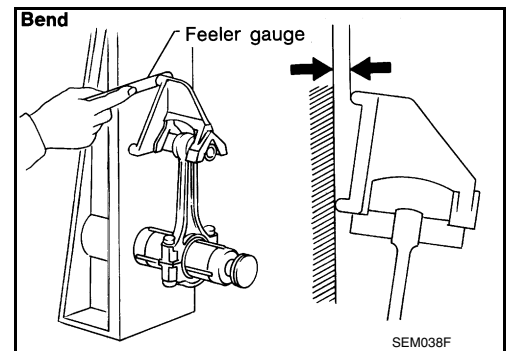

CONNECTING ROD BEARING HOUSING DIAMETER (BIG END)

- Install the connecting rod cap without the connecting rod bearing installed. After tightening the connecting rod nut to the specified torque, measure the connecting rod bearing housing big end inner diameter using an inside micrometer.

Standard : 55.000 - 55.013 mm (2.1654 - 2.1659 in)

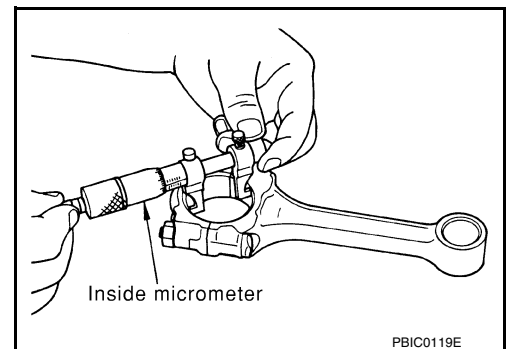

CONNECTING ROD BUSHING OIL CLEARANCE (SMALL END)

Inner Diameter of Connecting Rod (Small End)

CYLINDER BLOCK

< UNIT DISASSEMBLY AND ASSEMBLY >

- Measure inner diameter of piston pin bushing.

Standard Grade No. 0
: 22.000 - 22.006 mm (0.8661 - 0.8664 in)
Grade No. 1
: 22.006 - 22.012 mm (0.8664 - 0.8666 in)

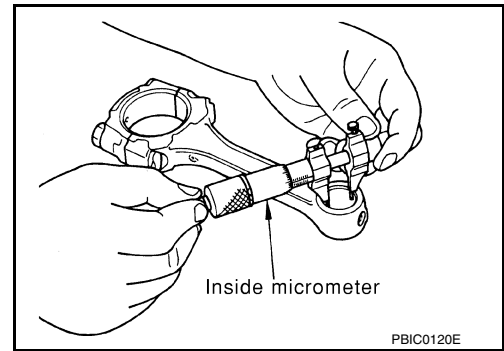

Outer Diameter of Piston Pin

- Measure outer diameter of piston pin.

Standard Grade No. 0
: 21.989 - 21.995 mm (0.8657 - 0.8659 in)
Grade No. 1
: 21.995 - 22.001 mm (0.8659 - 0.8662 in)

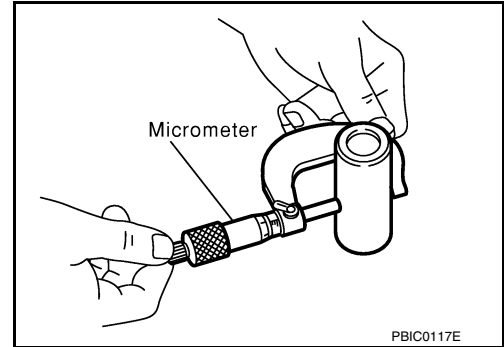

Connecting Rod Bushing Oil Clearance (Small End)

(Connecting rod small end oil clearance) = (Inner diameter of connecting rod small end) – (Outer diameter of piston pin)

Standard : 0.005 - 0.017 mm (0.0002 - 0.0007 in)
Limit : 0.030 mm (0.0012 in)

- If the measured value exceeds the standard, replace the connecting rod assembly and/or piston and piston pin assembly.
- If replacing the piston and piston pin assembly, use the Table for Selective Fitting for Piston to select the piston corresponding to the applicable bore grade of the cylinder block to be used. Follow the "PISTON-TO-CYLINDER BORE CLEARANCE" procedure.

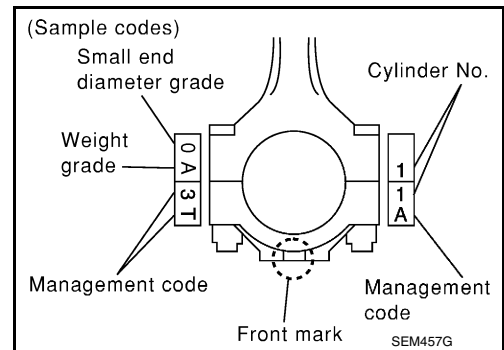

Factory installed parts grading:

- ← : Engine front
- (A) : Piston grade No.
- (B) : Piston front mark
- (C) : Oil hole
- (D) : Connecting rod front mark
- (E) : Cylinder No.
- (F) : Pin grade No.
- (G) : Crown I.D. code

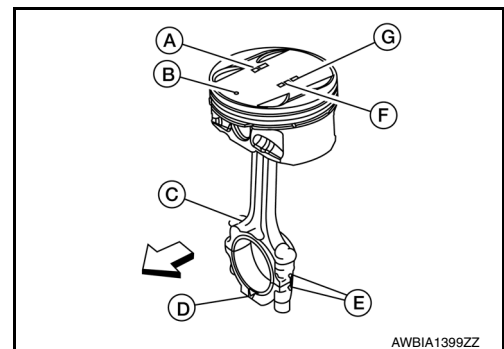

Service parts apply only to grade 0.

Unit: mm (in)

| Grade | 0 | 1 |
|---|--------------------------------------|--------------------------------------|
| Connecting rod small end inner diameter | 22.000 - 22.006 (0.8661 - 0.8664) | 22.006 - 22.012 (0.8664 - 0.8666) |

CYLINDER BLOCK

< UNIT DISASSEMBLY AND ASSEMBLY >

| | | |
|---------------------------|--------------------------------------|--------------------------------------|
| Piston pin outer diameter | 21.989 - 21.995 (0.8657 - 0.8659) | 21.995 - 22.001 (0.8659 - 0.8662) |
| Piston pin hole diameter | 21.993 - 21.999 (0.8659 - 0.8661) | 21.999 - 22.005 (0.8661 - 0.8663) |

CYLINDER BLOCK DISTORTION

- Using a scraper, remove any old gasket material on the cylinder block surface and remove any engine oil, scale, carbon, or other contamination.

CAUTION:

Be careful not to allow gasket flakes to enter the engine oil or engine coolant passages.

- Measure the distortion on the block upper face at different points in six directions.

Distortion limit : 0.10 mm (0.0039 in)

- If out of specification, resurface the cylinder block. The allowable amount of resurfacing is dependent on the amount of any cylinder head resurfacing. The resurfacing limit is [amount of cylinder head resurfacing] + [amount of cylinder head resurfacing] = 0.2 mm (0.008 in).

**Cylinder block height : 214.95 - 215.05 mm
(8.4626 - 8.4665 in)**

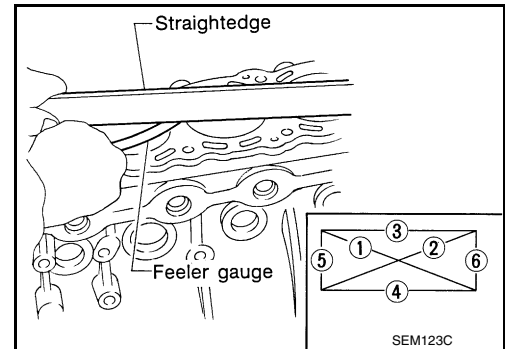

INNER DIAMETER OF MAIN BEARING HOUSING

- Install the main bearing caps with the main bearings removed, and tighten the bolts to the specified torque.
- Using suitable tool, measure the inner diameter of the main bearing housing (A).

Standard : 63.993 - 64.017 mm (2.5194 - 2.5203 in)

- If out of the standard, replace the cylinder block and main bearing caps as an assembly.

NOTE:

These components cannot be replaced as a single unit, because they were processed together.

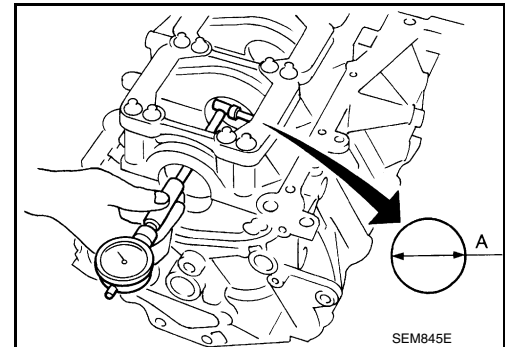

PISTON-TO-CYLINDER BORE CLEARANCE

- Using suitable tool, measure cylinder bore for wear, out-of-round and taper at (A), (B) and (C). The X axis is in the longitudinal direction of the engine.

Cylinder bore inner diameter

| Grade No. | Standard inner diameter | Wear limit |
|-----------|---|---------------------|
| No. 1 | 95.500 - 95.510 mm (3.7598 - 3.7602 in) | 0.20 mm (0.0079 in) |
| No. 2 | 95.510 - 95.520 mm (3.7602 - 3.7606 in) | |
| No. 3 | 95.520 - 95.530 mm (3.7606 - 3.7610 in) | |

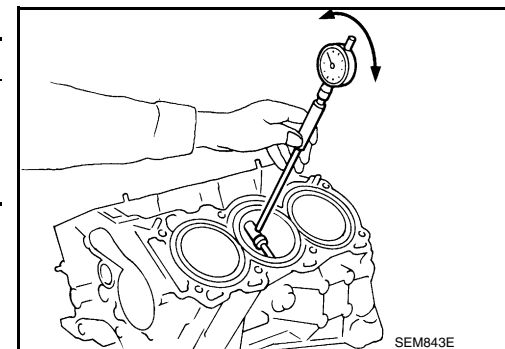

CYLINDER BLOCK

< UNIT DISASSEMBLY AND ASSEMBLY >

If it exceeds the limit, rebore all cylinders. Replace cylinder block if necessary.

- Out-of-round (Difference between X and Y) : limit 0.015 mm (0.0006 in)**
- Taper (Difference between A and C) : limit 0.010 mm (0.0004 in)**

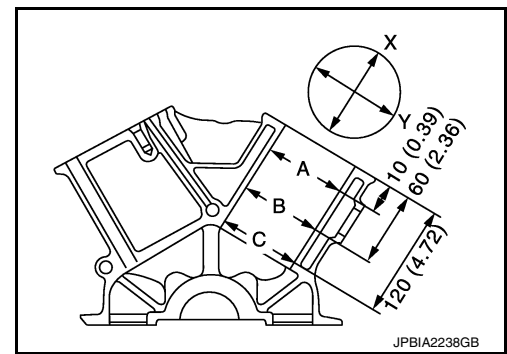

2. Check for scratches and seizure. If seizure is found, hone it.
 - **If both cylinder block and piston are replaced with new ones, select piston of the same grade number punched on cylinder block rear position. These numbers are punched in either Arabic or Roman numerals.**

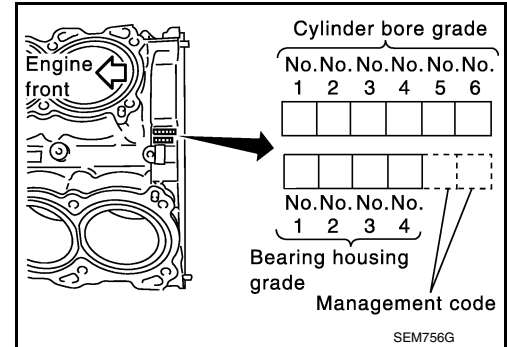

3. Measure piston skirt diameter, using suitable tool.

- Piston diameter (A) : Refer to EM-141, "Cylinder Block".**
- Measuring point (a) (Distance from the top) : 38.0 mm (1.496 in)**

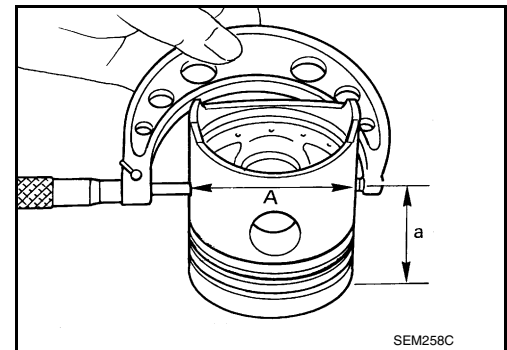

4. Check that piston-to-bore clearance is within specification.

- Piston-to-bore clearance at (B) : 0.010 - 0.030 mm (0.0004 - 0.0012 in)**
- The piston-to-bore clearance is measured at the (B) level in the cylinder as shown.

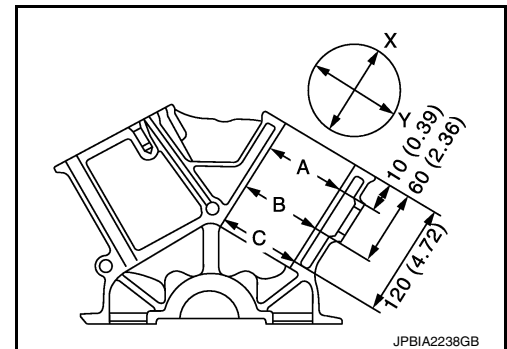

5. Cylinder bore size is determined by adding piston-to-bore clearance to piston diameter.

Rebored size calculation : $D = A + B - C$

where,

- (D) : Bored diameter**
- (A) : Piston diameter as measured**
- (B) : Piston-to-bore clearance**
- (C) : Honing allowance 0.02 mm (0.0008 in)**

A
EM
C
D
E
F
G
H
I
J
K
L
M
N
O
P

CYLINDER BLOCK

< UNIT DISASSEMBLY AND ASSEMBLY >

6. Install main bearing caps, and tighten to the specified torque. Otherwise, cylinder bores may be distorted after boring.
7. Cut cylinder bores.
 - **When any cylinder needs boring, all other cylinders must also be bored.**
 - **Do not cut too much out of cylinder bore at a time. Cut only 0.05 mm (0.0020 in) or so in diameter at a time.**
- 8.hone cylinders to obtain specified piston-to-bore clearance.
9. Measure finished cylinder bore for out-of-round and taper.
 - **Measurement should be done after cylinder bore cools down.**

CRANKSHAFT

1. Check the crankshaft main and pin journals for scoring, wear, or cracks.
2. Measure the journals for taper and out-of-round.

Standard

Out-of-round (X - Y) : 0.002 mm (0.0001 in)

Taper (A - B) : 0.002 mm (0.0001 in)

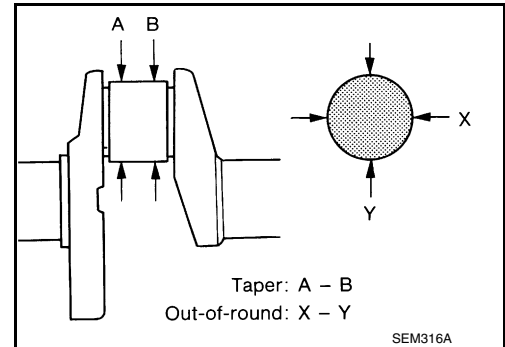

3. Measure crankshaft runout.
 - a. Place a V-block on a precise flat table to support the journals on the both ends of the crankshaft.
 - b. Place a dial gauge straight up on the No. 3 journal.
 - c. While rotating the crankshaft, read the movement of the pointer on the dial gauge.

Runout limit (total indicator reading) : 0.10 mm (0.0039 in)

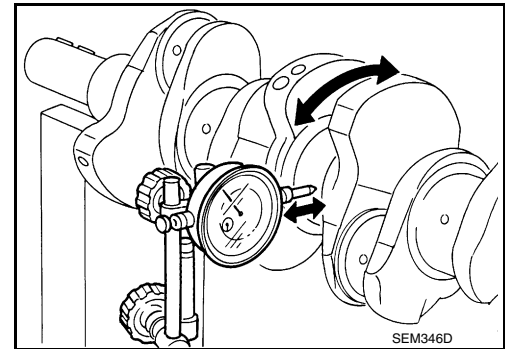

BEARING CLEARANCE

- Use either of the following two methods, however method (A) gives more reliable results and so is the preferred method.

Method A (Using Bore Gauge and Micrometer)

Main Bearing

1. Set the main bearings in their proper positions on the cylinder block and the main bearing cap.
2. Install the main bearing caps and bearing beam to the cylinder block. Tighten all bolts in the numerical order as specified. Refer to [EM-113. "Disassembly and Assembly"](#).

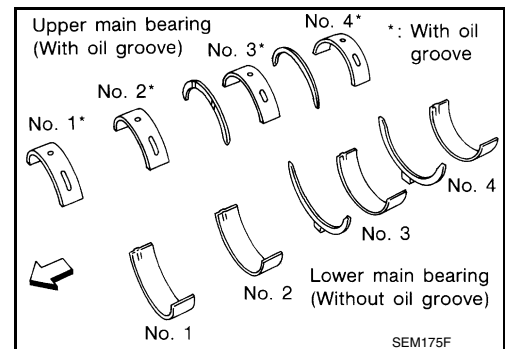

CYLINDER BLOCK

< UNIT DISASSEMBLY AND ASSEMBLY >

3. Measure the inner diameters (A) of each main bearing as shown.

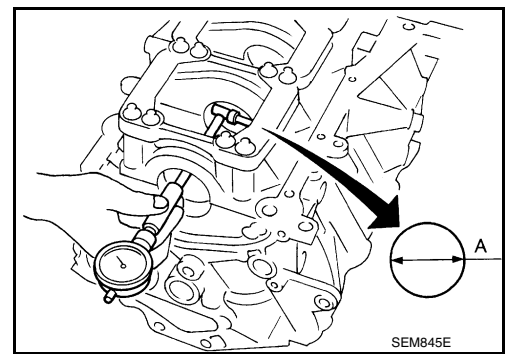

4. Measure the outer diameters (Dm) of each crankshaft main journal as shown.
5. Calculate the main bearing clearance.
Main bearing clearance = (A) - (Dm)

Standard : 0.035 - 0.045 mm (0.0014 - 0.0018 in)

Limit : 0.065 mm (0.0026 in)

- If it exceeds the limit, replace the bearing.
- If clearance cannot be adjusted using any standard bearing grade, grind crankshaft journal and use an undersized bearing.

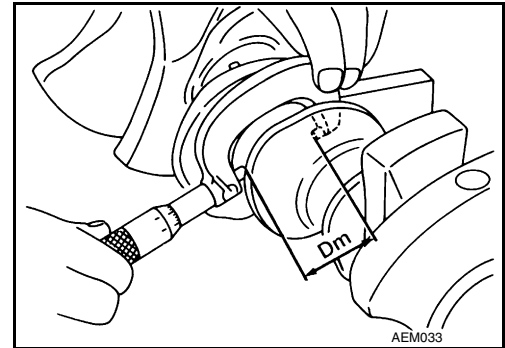

- When grinding the crankshaft journal, confirm that the (L) dimension in the fillet role is more than the specified limit.

(L) : 0.10 mm (0.0039 in)

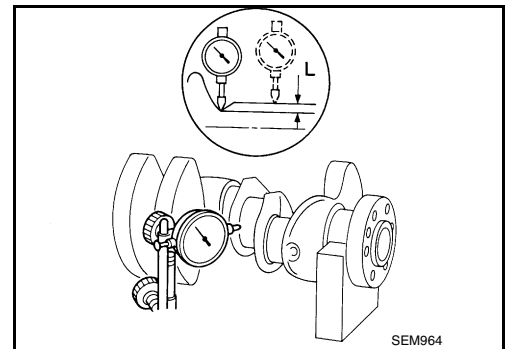

6. If the crankshaft or the cylinder block is replaced with a new one, select thickness of the main bearings as follows:

- a. The grade number of each cylinder block main journal is punched on the respective cylinder block. These numbers are punched in either Arabic or Roman numerals. If measured diameter is out of the grade punched, decide suitable grade from available main bearings.

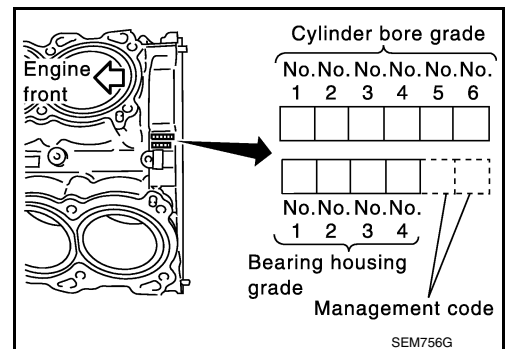

CYLINDER BLOCK

< UNIT DISASSEMBLY AND ASSEMBLY >

- b. The grade number of each crankshaft main journal is punched on the crankshaft end. These numbers are punched in either Arabic or Roman numerals. If measured diameter is out of grade punched, decide the suitable grade from available main bearings.

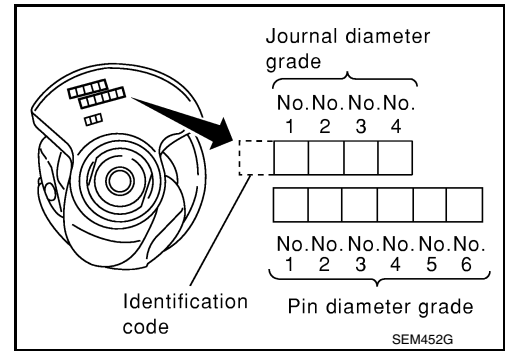

- c. Select the main bearing suitable thickness according to the following table:

| Mark | Axle diameter | Cylinder block bearing housing inner diameter Unit: mm (in) | | | | | | | | | | | | | | | | | | | | | | | | | |
|------|-----------------------------------|--|---|---|---|---|---|---|---|---|---|---|---|---|---|---|---|---|---|---|---|---|---|---|---|---|--|
| | | Hole diameter | | | | | | | | | | | | | | | | | | | | | | | | | |
| | | A | B | C | D | E | F | G | H | J | K | L | M | N | P | R | S | T | U | V | W | X | Y | 4 | 7 | | |
| A | 59.975 - 59.974 (2.3612 - 2.3612) | 0 | 0 | 0 | 0 | 0 | 1 | 1 | 1 | 1 | 1 | 1 | 1 | 1 | 1 | 1 | 1 | 1 | 1 | 1 | 1 | 1 | 1 | 1 | 1 | 1 | |
| B | 59.974 - 59.973 (2.3612 - 2.3611) | 0 | 0 | 0 | 1 | 1 | 1 | 1 | 1 | 1 | 1 | 1 | 1 | 1 | 1 | 1 | 1 | 1 | 1 | 1 | 1 | 1 | 1 | 1 | 1 | 1 | |
| C | 59.973 - 59.972 (2.3611 - 2.3611) | 0 | 0 | 1 | 1 | 1 | 1 | 1 | 1 | 1 | 1 | 1 | 1 | 1 | 1 | 1 | 1 | 1 | 1 | 1 | 1 | 1 | 1 | 1 | 1 | 1 | |
| D | 59.972 - 59.971 (2.3611 - 2.3611) | 0 | 1 | 1 | 1 | 1 | 1 | 1 | 1 | 1 | 1 | 1 | 1 | 1 | 1 | 1 | 1 | 1 | 1 | 1 | 1 | 1 | 1 | 1 | 1 | 1 | |
| E | 59.971 - 59.970 (2.3611 - 2.3610) | 0 | 1 | 1 | 1 | 1 | 1 | 1 | 1 | 1 | 1 | 1 | 1 | 1 | 1 | 1 | 1 | 1 | 1 | 1 | 1 | 1 | 1 | 1 | 1 | 1 | |
| F | 59.970 - 59.969 (2.3610 - 2.3610) | 0 | 1 | 1 | 1 | 1 | 1 | 1 | 1 | 1 | 1 | 1 | 1 | 1 | 1 | 1 | 1 | 1 | 1 | 1 | 1 | 1 | 1 | 1 | 1 | 1 | |
| G | 59.969 - 59.968 (2.3610 - 2.3609) | 1 | 1 | 1 | 1 | 1 | 1 | 1 | 1 | 1 | 1 | 1 | 1 | 1 | 1 | 1 | 1 | 1 | 1 | 1 | 1 | 1 | 1 | 1 | 1 | 1 | |
| H | 59.968 - 59.967 (2.3609 - 2.3609) | 1 | 1 | 1 | 1 | 1 | 1 | 1 | 1 | 1 | 1 | 1 | 1 | 1 | 1 | 1 | 1 | 1 | 1 | 1 | 1 | 1 | 1 | 1 | 1 | 1 | |
| J | 59.967 - 59.966 (2.3609 - 2.3609) | 1 | 1 | 1 | 1 | 1 | 1 | 1 | 1 | 1 | 1 | 1 | 1 | 1 | 1 | 1 | 1 | 1 | 1 | 1 | 1 | 1 | 1 | 1 | 1 | 1 | |
| K | 59.966 - 59.965 (2.3909 - 2.3608) | 1 | 1 | 1 | 1 | 1 | 1 | 1 | 1 | 1 | 1 | 1 | 1 | 1 | 1 | 1 | 1 | 1 | 1 | 1 | 1 | 1 | 1 | 1 | 1 | 1 | |
| L | 59.965 - 59.964 (2.3608 - 2.3608) | 1 | 1 | 1 | 1 | 1 | 1 | 1 | 1 | 1 | 1 | 1 | 1 | 1 | 1 | 1 | 1 | 1 | 1 | 1 | 1 | 1 | 1 | 1 | 1 | 1 | |
| M | 59.964 - 59.963 (2.3608 - 2.3607) | 1 | 1 | 1 | 1 | 1 | 1 | 1 | 1 | 1 | 1 | 1 | 1 | 1 | 1 | 1 | 1 | 1 | 1 | 1 | 1 | 1 | 1 | 1 | 1 | 1 | |
| N | 59.963 - 59.962 (2.3607 - 2.3607) | 2 | 2 | 2 | 2 | 2 | 2 | 2 | 2 | 2 | 2 | 2 | 2 | 2 | 2 | 2 | 2 | 2 | 2 | 2 | 2 | 2 | 2 | 2 | 2 | 2 | |
| P | 59.962 - 59.961 (2.3607 - 2.3607) | 2 | 2 | 2 | 2 | 2 | 2 | 2 | 2 | 2 | 2 | 2 | 2 | 2 | 2 | 2 | 2 | 2 | 2 | 2 | 2 | 2 | 2 | 2 | 2 | 2 | |
| R | 59.961 - 59.960 (2.3607 - 2.3606) | 2 | 2 | 2 | 2 | 2 | 2 | 2 | 2 | 2 | 2 | 2 | 2 | 2 | 2 | 2 | 2 | 2 | 2 | 2 | 2 | 2 | 2 | 2 | 2 | 2 | |
| S | 59.960 - 59.959 (2.3606 - 2.3606) | 2 | 2 | 2 | 2 | 2 | 2 | 2 | 2 | 2 | 2 | 2 | 2 | 2 | 2 | 2 | 2 | 2 | 2 | 2 | 2 | 2 | 2 | 2 | 2 | 2 | |
| T | 59.959 - 59.958 (2.3606 - 2.3605) | 2 | 2 | 2 | 2 | 2 | 2 | 2 | 2 | 2 | 2 | 2 | 2 | 2 | 2 | 2 | 2 | 2 | 2 | 2 | 2 | 2 | 2 | 2 | 2 | 2 | |
| U | 59.958 - 59.957 (2.3605 - 2.3605) | 2 | 2 | 2 | 2 | 2 | 2 | 2 | 2 | 2 | 2 | 2 | 2 | 2 | 2 | 2 | 2 | 2 | 2 | 2 | 2 | 2 | 2 | 2 | 2 | 2 | |
| V | 59.957 - 59.956 (2.3605 - 2.3605) | 3 | 3 | 3 | 3 | 3 | 3 | 3 | 3 | 3 | 3 | 3 | 3 | 3 | 3 | 3 | 3 | 3 | 3 | 3 | 3 | 3 | 3 | 3 | 3 | 3 | |
| W | 59.956 - 59.955 (2.3605 - 2.3604) | 3 | 3 | 3 | 3 | 3 | 3 | 3 | 3 | 3 | 3 | 3 | 3 | 3 | 3 | 3 | 3 | 3 | 3 | 3 | 3 | 3 | 3 | 3 | 3 | 3 | |
| X | 59.955 - 59.954 (2.3604 - 2.3604) | 3 | 3 | 3 | 3 | 3 | 3 | 3 | 3 | 3 | 3 | 3 | 3 | 3 | 3 | 3 | 3 | 3 | 3 | 3 | 3 | 3 | 3 | 3 | 3 | 3 | |
| Y | 59.954 - 59.953 (2.3604 - 2.3603) | 3 | 3 | 3 | 3 | 3 | 3 | 3 | 3 | 3 | 3 | 3 | 3 | 3 | 3 | 3 | 3 | 3 | 3 | 3 | 3 | 3 | 3 | 3 | 3 | 3 | |
| 4 | 59.953 - 59.952 (2.3603 - 2.3603) | 3 | 3 | 3 | 3 | 3 | 3 | 3 | 3 | 3 | 3 | 3 | 3 | 3 | 3 | 3 | 3 | 3 | 3 | 3 | 3 | 3 | 3 | 3 | 3 | 3 | |
| 7 | 59.952 - 59.951 (2.3603 - 2.3603) | 3 | 3 | 3 | 3 | 3 | 3 | 3 | 3 | 3 | 3 | 3 | 3 | 3 | 3 | 3 | 3 | 3 | 3 | 3 | 3 | 3 | 3 | 3 | 3 | 3 | |

Connecting Rod Bearing (Big End)

1. Install the connecting rod bearing to the connecting rod and cap.
2. Install the connecting rod cap to the connecting rod. Tighten to specification. Refer to [EM-113, "Disassembly and Assembly"](#).

CYLINDER BLOCK

< UNIT DISASSEMBLY AND ASSEMBLY >

- Measure the inner diameter (C) of each connecting rod (big end) as shown.

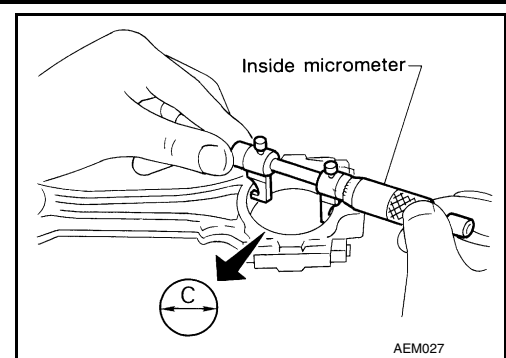

- Measure the outer diameter (Dp) of each crankshaft pin journal.
- Calculate the connecting rod bearing clearance.
Connecting rod bearing clearance = (C) - (Dp)

Standard : 0.020 - 0.045 mm (0.0008 - 0.0018 in)

Limit : 0.070 mm (0.0028 in)

- If the calculated clearance exceeds the specified limit, replace the bearings.
- If the clearance cannot be adjusted within the standard of any bearing, grind the crankshaft journal and use undersized bearings.

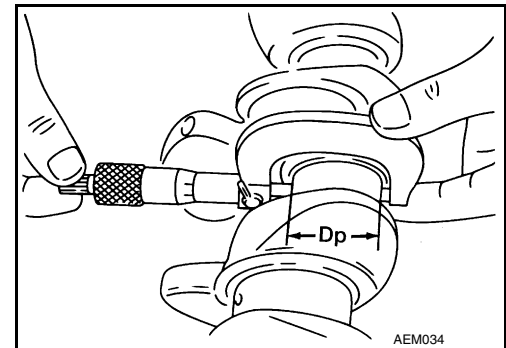

- If the crankshaft is replaced with a new one, select the connecting rod bearings according to the following table:
Connecting Rod Bearing Grade Number (Identification Color)

| Crankshaft pin journal grade number | Connecting rod bearing grade number |
|-------------------------------------|-------------------------------------|
| 0 | 0 (black) |
| 1 | 1 (brown) |
| 2 | 2 (green) |

These numbers are punched in either Arabic or Roman numerals.

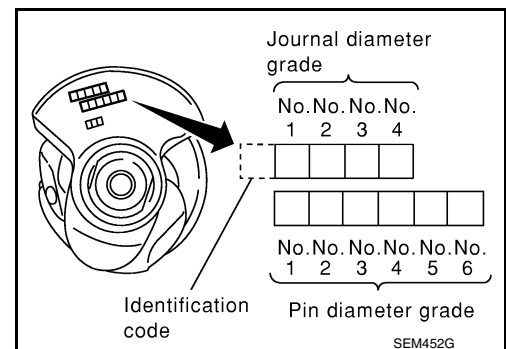

Method B (Using Plastigage)

- Remove engine oil and dust on the crankshaft pin and the surfaces of each bearing completely.
- Cut a Plastigage slightly shorter than the bearing width, and place it in crankshaft axial direction, avoiding oil holes.
- Install the connecting rod bearings to the connecting rod cap, and tighten the connecting rod nuts to the specified torque.

CAUTION:

Do not rotate the crankshaft.

- Remove the connecting rod cap and bearings, and using the scale on the Plastigage bag, measure the Plastigage width.

NOTE:

The procedure when the measured value exceeds the repair limit is same as that described in "Method A (Using Bore Gauge and Micrometer)".

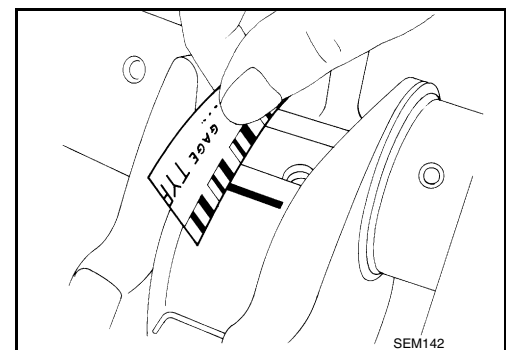

DRIVE PLATE RUNOUT

CYLINDER BLOCK

< UNIT DISASSEMBLY AND ASSEMBLY >

Use a suitable tool to measure the runout (Total Indicator Reading) as shown.

Drive plate torque converter surface : less than 0.35 mm (.0138 in)

Ring gear : less than 0.5 mm (.0197 in)

CAUTION:

- The signal plate is built into the drive assembly. Be careful not to damage the signal plate, particularly the teeth.

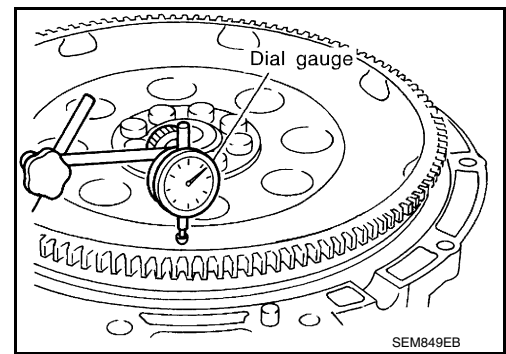

- Check the drive plate and signal plate for deformation or cracks.
- Keep all magnetized objects away from the signal plate, particularly the teeth.

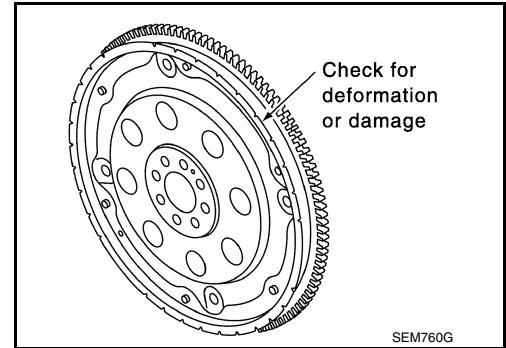

OIL JET

- Check nozzle for deformation and damage.
- Blow compressed air from nozzle, and check for clogs.
- If it is not operating properly, replace oil jet.

OIL JET RELIEF VALVE

- Using a clean plastic stick, press check valve in oil jet relief valve. Make sure that valve moves smoothly with proper reaction force.
- If it is not operating properly, replace oil jet relief valve.

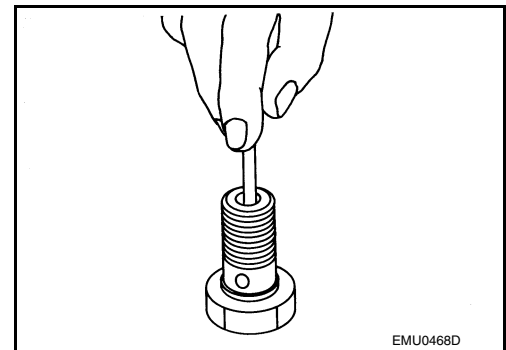

Dowel Pin Alignment

INFOID:0000000011148421

REMOVAL

1. Use suitable tool to lock the drive plate and match mark (A) before removing the bolts.

CAUTION:

Do not damage the ring gear teeth or the signal plate teeth behind the ring gear.

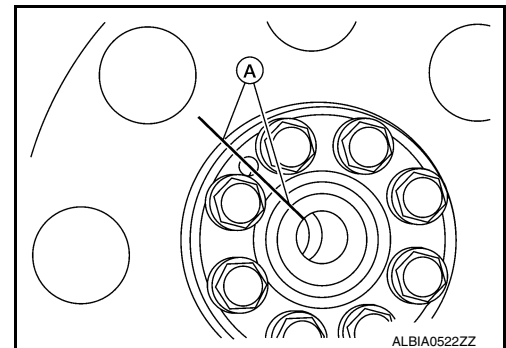

CYLINDER BLOCK

< UNIT DISASSEMBLY AND ASSEMBLY >

2. Remove drive plate.
 - Loosen the drive plate in a diagonal order.
 - CAUTION:**
 - **Do not place drive plate with signal plate facing down.**
 - **When handling the signal plate, take care not to damage or scratch it.**
 - **Handle the signal plate in a manner that prevents it from becoming magnetized.**

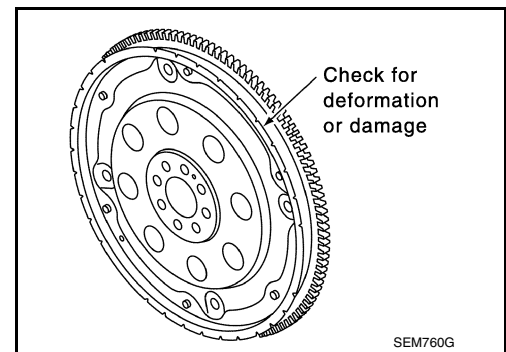

INSTALLATION

Installation is in the reverse order of removal.

- When installing the drive plate to the crankshaft, use the match mark (A) as shown to correctly align the crankshaft side dowel pin to the drive plate side dowel pin hole.

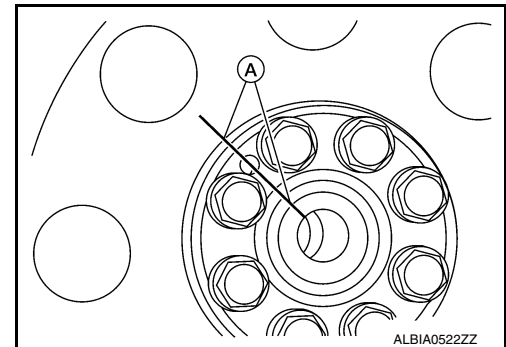

- Install the drive plate and the reinforcement plate in the direction as shown.

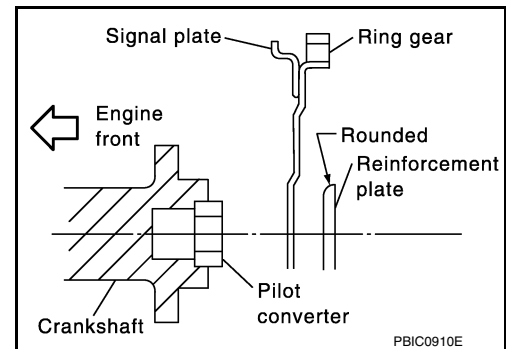

- Tighten the drive plate bolts in a diagonal pattern in two steps. Refer to [EM-113, "Disassembly and Assembly"](#).
- Use a suitable tool to lock the drive plate.

SERVICE DATA AND SPECIFICATIONS (SDS)

< SERVICE DATA AND SPECIFICATIONS (SDS)

SERVICE DATA AND SPECIFICATIONS (SDS)

SERVICE DATA AND SPECIFICATIONS (SDS)

General Specification

INFOID:0000000011148422

GENERAL SPECIFICATIONS

| | | |
|--|--------------------------------------|-----------------------------|
| Cylinder arrangement | | V-6 |
| Displacement cm ³ (cu in) | | 3,498 (213.45) |
| Bore and stroke mm (in) | | 95.5 x 81.4 (3.760 x 3.205) |
| Valve arrangement | | DOHC |
| Firing order | | 1-2-3-4-5-6 |
| Number of piston rings | Compression | 2 |
| | Oil | 1 |
| Number of main bearings | | 4 |
| Compression ratio | | 10.6:1 |
| Compression pressure kPa (kg/cm ² , psi)/300 rpm | Standard | 1,275 (13.0, 185) |
| | Minimum | 981 (10.0, 142) |
| | Differential limit between cylinders | 98 (1.0, 14) |

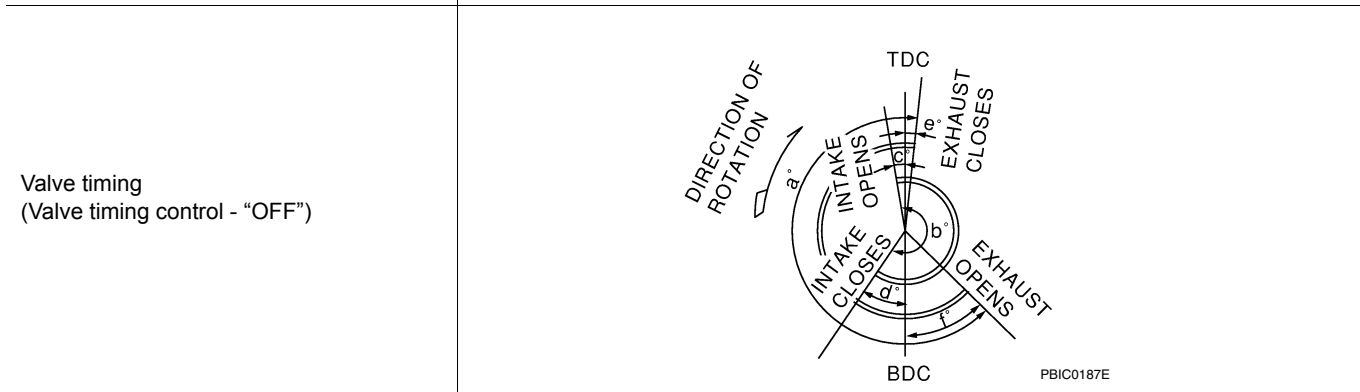
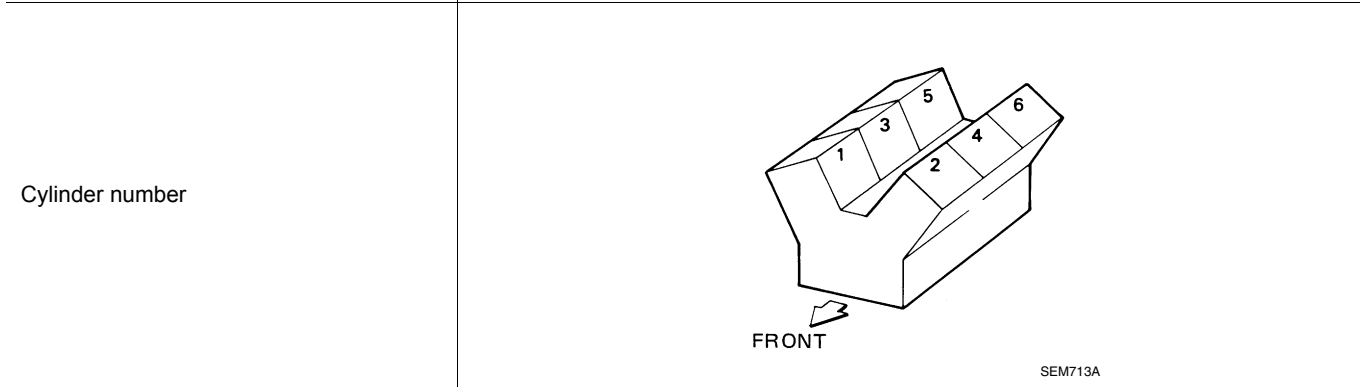

Unit: degree

| a | b | c | d | e | f |
|-----|-----|-----|----|----|----|
| 240 | 240 | -10 | 70 | 10 | 50 |

Drive Belt

INFOID:0000000011148423

DRIVE BELT

| | |
|-----------------------|--|
| Tension of drive belt | Belt tension is not necessary, as it is automatically adjusted by drive belt auto-tensioner. |
|-----------------------|--|

SERVICE DATA AND SPECIFICATIONS (SDS)

< SERVICE DATA AND SPECIFICATIONS (SDS)

Spark Plug

INFOID:0000000011148424

SPARK PLUG

Unit: mm (in)

| | | |
|----------------|-----------|-------------|
| Make | DENSO | |
| Standard type* | FXE22HR11 | |
| Gap | Standard | 1.1 (0.043) |

*: Always check with the Parts Department for the latest parts information.

Intake Manifold

INFOID:0000000011148425

INTAKE MANIFOLD

Unit: mm (in)

| Items | | Limit |
|--------------------|-----------------|-------------|
| Surface distortion | Intake manifold | 0.1 (0.004) |

Exhaust Manifold

INFOID:0000000011148426

EXHAUST MANIFOLD

Unit: mm (in)

| Items | | Limit |
|--------------------|------------------|-------------|
| Surface distortion | Exhaust manifold | 0.3 (0.012) |

Camshaft

INFOID:0000000011148427

CAMSHAFT

Unit: mm (in)

| Items | | Standard | Limit |
|---|-------------|-----------------------------------|---------------------------|
| Camshaft journal oil clearance | No. 1 | 0.045 - 0.086 (0.0018 - 0.0034) | 0.15 (0.0059) |
| | No. 2, 3, 4 | 0.035 - 0.076 (0.0014 - 0.0030) | |
| Camshaft bracket inner diameter | No. 1 | 26.000 - 26.021 (1.0236 - 1.0244) | — |
| | No. 2, 3, 4 | 23.500 - 23.521 (0.9252 - 0.9260) | — |
| Camshaft journal diameter | No. 1 | 25.935 - 25.955 (1.0211 - 1.0218) | — |
| | No. 2, 3, 4 | 23.445 - 23.465 (0.9230 - 0.9238) | — |
| Camshaft end play | | 0.115 - 0.188 (0.0045 - 0.0074) | 0.24 (0.0094) |
| Camshaft lobe height "A" | Intake | 45.475 - 45.665 (1.7904 - 1.7978) | 0.2 (0.008)* ¹ |
| | Exhaust | 45.485 - 45.675 (1.7907 - 1.7982) | 0.2 (0.008)* ¹ |
| Camshaft runout [TIR* ²] | | Less than 0.02 (0.0008) | 0.05 (0.0020) |
| Camshaft sprocket runout [TIR* ²] | | Less than 0.15 (0.0059) | — |

SERVICE DATA AND SPECIFICATIONS (SDS)

< SERVICE DATA AND SPECIFICATIONS (SDS)

| | | |
|---|--|---|
| Difference in level between front end faces of No. 1 camshaft bracket and cylinder head | : - 0.14 to 0.14mm (- 0.0055 to 0.0055 in) | — |
|---|--|---|

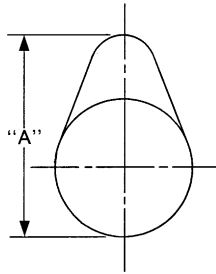

SEM671

*1: Cam wear limit

*2: Total indicator reading

VALVE LIFTER

Unit: mm (in)

| Items | Standard |
|-----------------------------|-----------------------------------|
| Valve lifter outer diameter | 33.977 - 33.987 (1.3377 - 1.3381) |
| Valve lifter bore diameter | 34.000 - 34.016 (1.3386 - 1.3392) |
| Valve lifter clearance | 0.013 - 0.039 (0.0005 - 0.0015) |

VALVE CLEARANCE

Unit: mm (in)

| Items | Cold | Hot* (reference data) |
|---------|-----------------------------|-------------------------------|
| Intake | 0.26 - 0.34 (0.010 - 0.013) | 0.304 - 0.416 (0.012 - 0.016) |
| Exhaust | 0.29 - 0.37 (0.011 - 0.015) | 0.308 - 0.432 (0.012 - 0.017) |

*: Approximately 80°C (176°F)

AVAILABLE VALVE LIFTER

Unit: mm (in)

| Identification (stamped) mark* | Thickness |
|--------------------------------|---------------|
| 788U | 7.88 (0.3102) |
| 790U | 7.90 (0.3110) |
| 792U | 7.92 (0.3118) |
| 794U | 7.94 (0.3126) |
| 796U | 7.96 (0.3134) |
| 798U | 7.98 (0.3142) |
| 800U | 8.00 (0.3150) |
| 802U | 8.02 (0.3157) |
| 804U | 8.04 (0.3165) |
| 806U | 8.06 (0.3173) |
| 808U | 8.08 (0.3181) |
| 810U | 8.10 (0.3189) |
| 812U | 8.12 (0.3197) |
| 814U | 8.14 (0.3205) |
| 816U | 8.16 (0.3213) |
| 818U | 8.18 (0.3220) |

SERVICE DATA AND SPECIFICATIONS (SDS)

< SERVICE DATA AND SPECIFICATIONS (SDS)

| Identification (stamped) mark* | Thickness |
|--------------------------------|---------------|
| 820U | 8.20 (0.3228) |
| 822U | 8.22 (0.3236) |
| 824U | 8.24 (0.3244) |
| 826U | 8.26 (0.3252) |
| 828U | 8.28 (0.3260) |
| 830U | 8.30 (0.3268) |
| 832U | 8.32 (0.3276) |
| 834U | 8.34 (0.3283) |
| 836U | 8.36 (0.3291) |
| 838U | 8.38 (0.3299) |
| 840U | 8.40 (0.3307) |

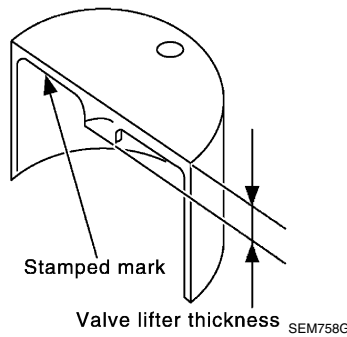

*: Always check with the Parts Department for the latest parts information.

Cylinder Head

INFOID:0000000011148428

CYLINDER HEAD

Unit: mm (in)

| Items | Standard | Limit |
|-------------------------------------|---------------------------------------|-------------|
| Head surface distortion | Less than 0.03 (0.0012) | 0.1 (0.004) |
| Normal cylinder head height (H) | 126.3 - 126.5 (4.97 - 4.98) | — |
| Spark plug tube installation height | 38.2 +0.9/- 0.5 (1.5 +0.035 / -0.020) | — |

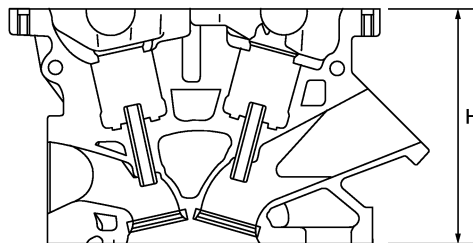

PBIC0924E

VALVE DIMENSIONS

SERVICE DATA AND SPECIFICATIONS (SDS)

< SERVICE DATA AND SPECIFICATIONS (SDS)

Unit: mm (in)

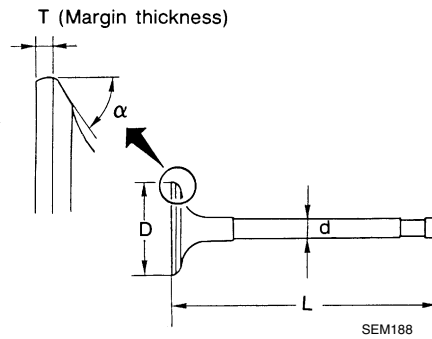

| | | |
|---------------------------------------|---------|---------------------------------|
| Valve head diameter (D) | Intake | 36.6 - 36.9 (1.441 - 1.453) |
| | Exhaust | 30.2 - 30.5 (1.189 - 1.201) |
| Valve length (L) | Intake | 97.13 (3.8240) |
| | Exhaust | 94.67 (3.7272) |
| Valve stem diameter (d) | Intake | 5.965 - 5.980 (0.2348 - 0.2354) |
| | Exhaust | 5.955 - 5.970 (0.2344 - 0.2350) |
| Valve seat angle α | Intake | 45°15' - 45°45' |
| | Exhaust | |
| Valve margin (T) | Intake | 1.15 - 1.45 (0.0453 - 0.0571) |
| | Exhaust | 1.45 - 1.75 (0.0571 - 0.0689) |
| Valve margin (T) limit | | More than 0.5 (0.020) |
| Valve stem end surface grinding limit | | Less than 0.2 (0.008) |

Valve Oil Seal

Unit: mm (in)

| Items | Standard |
|-------|----------|
|-------|----------|

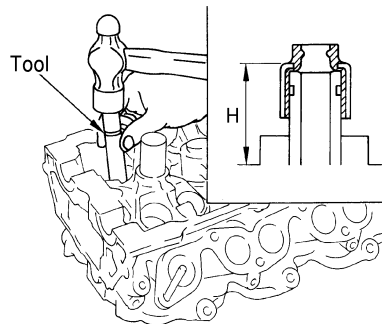

WBIA0490E

| | |
|---|-----------------------------------|
| Height (H) (without valve spring installed) | 14.300 - 14.900 (0.5630 - 0.5870) |
|---|-----------------------------------|

VALVE GUIDE

SERVICE DATA AND SPECIFICATIONS (SDS)

< SERVICE DATA AND SPECIFICATIONS (SDS)

Unit: mm (in)

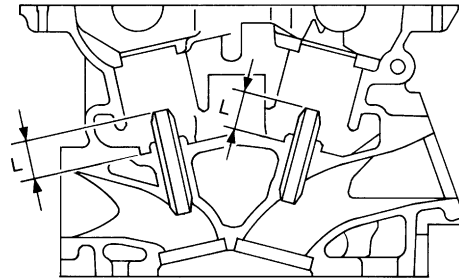

SEM950E

| Items | | Standard | Oversize (Service) [0.2 (0.008)] |
|---|--------------------------------|-----------------------------------|-----------------------------------|
| Valve guide | Outer diameter | 10.023 - 10.034 (0.3946 - 0.3950) | 10.223 - 10.234 (0.4025 - 0.4029) |
| | Inner diameter (Finished size) | 6.000 - 6.018 (0.2362 - 0.2369) | |
| Cylinder head valve guide hole diameter | | 9.975 - 9.996 (0.3927 - 0.3935) | 10.175 - 10.196 (0.4006 - 0.4014) |
| Interference fit of valve guide | | 0.027 - 0.059 (0.0011 - 0.0023) | |
| Items | | Standard | Limit |
| Valve guide clearance | Intake | 0.020 - 0.053 (0.0008 - 0.0021) | 0.08 (0.0031) |
| | Exhaust | 0.040 - 0.073 (0.0016 - 0.0029) | 0.01 (0.004) |
| Valve deflection | Intake | — | 0.24 (0.0094) |
| | Exhaust | — | 0.28 (0.0110) |
| Projection length (L) | | 12.6 - 12.8 (0.496 - 0.504) | |

VALVE SEAT

A
EM
C
D
E
F
G
H
I
J
K
L
M
N
O
P

SERVICE DATA AND SPECIFICATIONS (SDS)

< SERVICE DATA AND SPECIFICATIONS (SDS)

Unit: mm (in)

| Items | Standard | Oversize (Service) [0.5 (0.02)] |
|-------|----------|---------------------------------|
|-------|----------|---------------------------------|

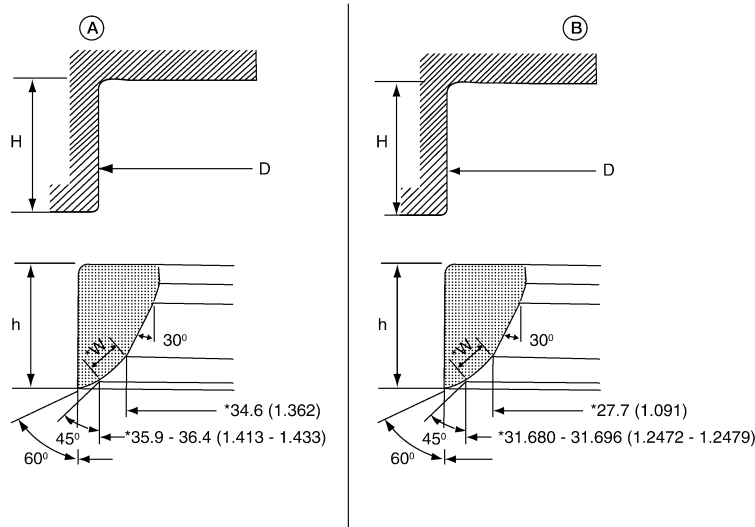

AWBIA0033GB

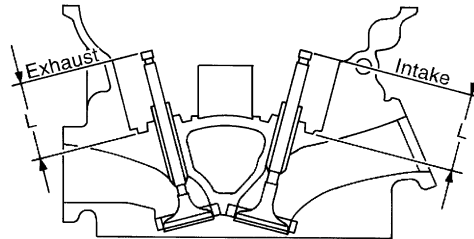

SEM621F

| | | | |
|--|-------------|-----------------------------------|-----------------------------------|
| Cylinder head seat recess diameter (D) | Intake (A) | 38.000 - 38.016 (1.4961 - 1.4967) | 38.500 - 38.516 (1.5157 - 1.5164) |
| | Exhaust (B) | 31.600 - 31.616 (1.2441 - 1.2447) | 32.100 - 32.116 (1.2638 - 1.2644) |
| Valve seat outer diameter | Intake | 38.097 - 38.113 (1.4999 - 1.5005) | 38.597 - 38.613 (1.5196 - 1.5202) |
| | Exhaust | 31.680 - 31.696 (1.2472 - 1.2479) | 32.180 - 32.196 (1.2669 - 1.2676) |
| Valve seat interference fit | Intake | 0.081 - 0.113 (0.0032 - 0.0044) | |
| | Exhaust | 0.064 - 0.096 (0.0025 - 0.0038) | |
| Height (h) | Intake (A) | 5.9 - 6.0 (0.232 - 0.236) | 5.0 - 5.1 (0.197 - 0.201) |
| | Exhaust (B) | 5.9 - 6.0 (0.232 - 0.236) | 4.9 - 5.0 (0.193 - 0.197) |
| Contacting width (W)* | Intake (A) | 1.18 - 1.22 (0.0465 - 0.0480) | |
| | Exhaust (B) | 1.38 - 1.42 (0.0543 - 0.0559) | |
| Cylinder head seat recess depth (H) | | 6.0 (0.236) | |
| Depth (L) | Intake (A) | 41.16 - 41.76 (1.6205 - 1.6441) | |
| | Exhaust (B) | 41.09 - 41.69 (1.6177 - 1.6413) | |

*:Machining data

VALVE SPRING

| Items | Standard |
|---------------------|--|
| Free height | 47.07 mm (1.8531 in) |
| Installation height | 37.00 mm (1.4567 in) |
| Installation load | 166 - 188 N (16.9 - 19.2 kg, 37 - 42 lb) |

SERVICE DATA AND SPECIFICATIONS (SDS)

< SERVICE DATA AND SPECIFICATIONS (SDS)

| Items | Standard |
|--------------------------|--|
| Height during valve open | 27.20 mm (1.0709 in) |
| Load with valve open | 373 - 421 N (38.0 - 42.9 kg, 84 - 95 lb) |

Unit: mm (in)

| Items | Limit |
|------------|-------------|
| Squareness | 2.0 (0.079) |

Cylinder Block

INFOID:0000000011148429

CYLINDER BLOCK

Unit: mm (in)

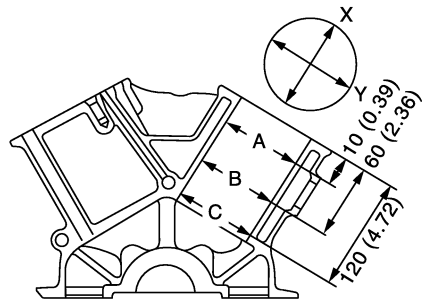

JPBIA2238GB

| | | | | |
|-------------------------------------|----------------|------------|-------------|-----------------------------------|
| Surface distortion | | Standard | | Less than 0.03 (0.0012) |
| | | Limit | | 0.10 (0.0039) |
| Main bearing housing inner diameter | | Standard | | 63.993 - 64.017 (2.5194 - 2.5203) |
| Cylinder bore | Inner diameter | Standard | Grade No. 1 | 95.500 - 95.510 (3.7598 - 3.7602) |
| | | | Grade No. 2 | 95.510 - 95.520 (3.7602 - 3.7606) |
| | | | Grade No. 3 | 95.520 - 95.530 (3.7606 - 3.7610) |
| | | Wear limit | | 0.20 (0.0079) |
| Out-of-round | | Limit | | 0.015 (0.0006) |
| Taper (Difference between A and C) | | | | 0.015 (0.0006) |

SERVICE DATA AND SPECIFICATIONS (SDS)

< SERVICE DATA AND SPECIFICATIONS (SDS)

| | | |
|---|-----------------------------------|-----------------------------------|
| Main bearing housing inner diameter grade (Without bearing) | Grade No. A | 63.993 - 63.994 (2.5194 - 2.5194) |
| | Grade No. B | 63.994 - 63.995 (2.5194 - 2.5195) |
| | Grade No. C | 63.995 - 63.996 (2.5195 - 2.5195) |
| | Grade No. D | 63.996 - 63.997 (2.5195 - 2.5196) |
| | Grade No. E | 63.997 - 63.998 (2.5196 - 2.5196) |
| | Grade No. F | 63.998 - 63.999 (2.5196 - 2.5196) |
| | Grade No. G | 63.999 - 64.000 (2.5196 - 2.5197) |
| | Grade No. H | 64.000 - 64.001 (2.5197 - 2.5197) |
| | Grade No. J | 64.001 - 64.002 (2.5197 - 2.5198) |
| | Grade No. K | 64.002 - 64.003 (2.5198 - 2.5198) |
| | Grade No. L | 64.003 - 64.004 (2.5198 - 2.5198) |
| | Grade No. M | 64.004 - 64.005 (2.5198 - 2.5199) |
| | Grade No. N | 64.005 - 64.006 (2.5199 - 2.5199) |
| | Grade No. P | 64.006 - 64.007 (2.5199 - 2.5200) |
| | Grade No. R | 64.007 - 64.008 (2.5200 - 2.5200) |
| | Grade No. S | 64.008 - 64.009 (2.5200 - 2.5200) |
| | Grade No. T | 64.009 - 64.010 (2.5200 - 2.5201) |
| | Grade No. U | 64.010 - 64.011 (2.5201 - 2.5201) |
| Grade No. V | 64.011 - 64.012 (2.5201 - 2.5202) | |
| Grade No. W | 64.012 - 64.013 (2.5202 - 2.5202) | |
| Grade No. X | 64.013 - 64.014 (2.5202 - 2.5202) | |
| Grade No. Y | 64.014 - 64.015 (2.5202 - 2.5203) | |
| Grade No. 4 | 64.015 - 64.016 (2.5203 - 2.5203) | |
| Grade No. 7 | 64.016 - 64.017 (2.5203 - 2.5203) | |
| Difference in inner diameter between cylinders | Standard | Less than 0.03 (0.0012) |

AVAILABLE PISTON

Unit: mm (in)

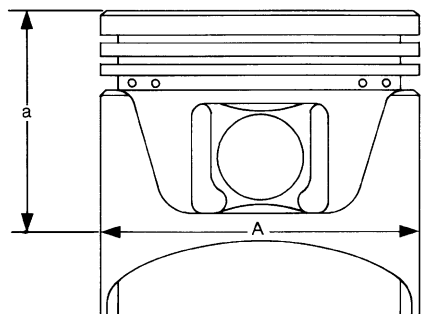

| Items | Grade* | Standard |
|-----------------------------------|-------------|-----------------------------------|
| Piston skirt diameter (A) | Grade No. 1 | 95.480 - 95.490 (3.7590 - 3.7594) |
| | Grade No. 2 | 95.490 - 95.500 (3.7594 - 3.7598) |
| | Grade No. 3 | 95.500 - 95.510 (3.7598 - 3.7602) |
| (a) dimension | | 38.0 (1.496) |
| Piston pin hole diameter | Grade No. 0 | 21.993 - 21.999 (0.8659 - 0.8661) |
| | Grade No. 1 | 21.999 - 22.005 (0.8661 - 0.8663) |
| Piston to cylinder bore clearance | | 0.010 - 0.030 (0.0004 - 0.0012) |

*: Always check with the Parts Department for the latest parts information.

PISTON RING

Unit: mm (in)

| Items | Standard | Limit |
|----------------|----------|---------------------------------|
| Side clearance | Top | 0.045 - 0.080 (0.0018 - 0.0031) |
| | 2nd | 0.030 - 0.070 (0.0012 - 0.0028) |
| | Oil ring | 0.065 - 0.125 (0.0018 - 0.0049) |
| | | — |

SERVICE DATA AND SPECIFICATIONS (SDS)

< SERVICE DATA AND SPECIFICATIONS (SDS)

| | | | |
|---------|-----------------|-------------------------------|---------------|
| End gap | Top | 0.23 - 0.28 (0.0091 - 0.0110) | 0.50 (0.0197) |
| | 2nd | 0.33 - 0.43 (0.0130 - 0.0169) | 0.62 (0.0244) |
| | Oil (rail ring) | 0.20 - 0.45 (0.0079 - 0.0177) | 0.80 (0.0315) |

PISTON PIN

Unit: mm (in)

| Items | Grade* | Standard | Limit |
|--------------------------------------|-------------|-----------------------------------|----------------|
| Piston pin outer diameter | Grade No. 0 | 21.989 - 21.995 (0.8657 - 0.8659) | — |
| | Grade No. 1 | 21.995 - 22.001 (0.8659 - 0.8662) | — |
| Piston to piston pin oil clearance | | 0.002 - 0.010 (0.0001 - 0.0004) | — |
| Connecting rod bushing oil clearance | | 0.005 - 0.017 (0.0002 - 0.0007) | 0.030 (0.0012) |

*: Always check with the Parts Department for the latest parts information.

CONNECTING ROD

Unit: mm (in)

| Items | Grade ¹ | Standard | Limit |
|--|--------------------|-----------------------------------|---------------|
| Center distance | | 144.15 - 144.25 (5.68 - 5.68) | — |
| Bend [per 100 (3.94)] | | — | 0.15 (0.0059) |
| Torsion [per 100 (3.94)] | | — | 0.30 (0.0118) |
| Connecting rod small end inner diameter | | 23.980 - 24.000 (0.9441 - 0.9449) | — |
| Connecting rod bushing inner diameter ² | Grade No. 0 | 22.000 - 22.006 (0.8661 - 0.8664) | — |
| | Grade No. 1 | 22.006 - 22.012 (0.8664 - 0.8666) | — |
| Connecting rod big end diameter (Without bearing) | | 55.000 - 55.013 (2.1654 - 2.1659) | — |
| Side clearance | | 0.20 - 0.35 (0.0079 - 0.0138) | 0.40 (0.0157) |

¹: Always check with the Parts Department for the latest parts information.

²: After installing in connecting rod.

CRANKSHAFT

Unit: mm (in)

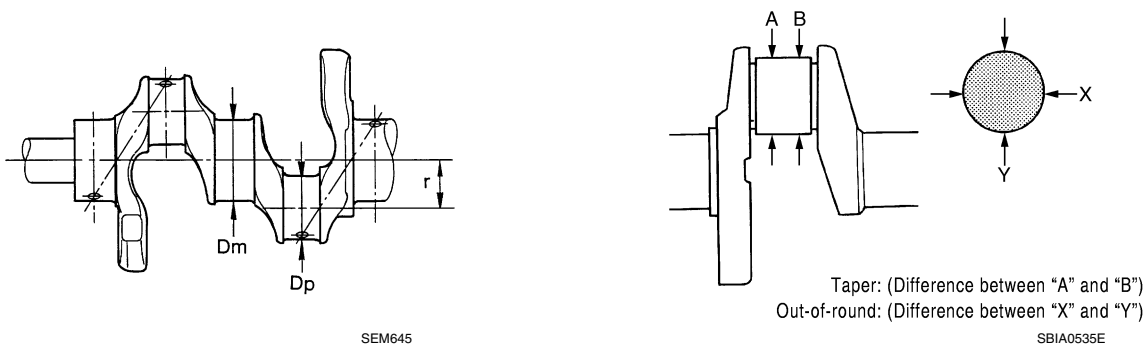

SERVICE DATA AND SPECIFICATIONS (SDS)

< SERVICE DATA AND SPECIFICATIONS (SDS)

| | | Grade ¹ | Dimension |
|---|-----------------------------------|----------------------------------|-----------------------------------|
| | | Main journal diameter.(Dm) grade | Standard |
| Grade No. B | 59.974 - 59.973 (2.3612 - 2.3611) | | |
| Grade No. C | 59.973 - 59.972 (2.3611 - 2.3611) | | |
| Grade No. D | 59.972 - 59.971 (2.3611 - 2.3611) | | |
| Grade No. E | 59.971 - 59.970 (2.3611 - 2.3610) | | |
| Grade No. F | 59.970 - 59.969 (2.3610 - 2.3610) | | |
| Grade No. G | 59.969 - 59.968 (2.3610 - 2.3609) | | |
| Grade No. H | 59.968 - 59.967 (2.3609 - 2.3609) | | |
| Grade No. J | 59.967 - 59.966 (2.3609 - 2.3609) | | |
| Grade No. K | 59.966 - 59.965 (2.3609 - 2.3608) | | |
| Grade No. L | 59.965 - 59.964 (2.3608 - 2.3608) | | |
| Grade No. M | 59.964 - 59.963 (2.3608 - 2.3607) | | |
| Grade No. N | 59.963 - 59.962 (2.3607 - 2.3607) | | |
| Grade No. P | 59.962 - 59.961 (2.3607 - 2.3607) | | |
| Grade No. R | 59.961 - 59.960 (2.3607 - 2.3606) | | |
| Grade No. S | 59.960 - 59.959 (2.3606 - 2.3606) | | |
| Grade No. T | 59.959 - 59.958 (2.3606 - 2.3605) | | |
| Grade No. U | 59.958 - 59.957 (2.3605 - 2.3605) | | |
| Grade No. V | 59.957 - 59.956 (2.3605 - 2.3605) | | |
| Grade No. W | 59.956 - 59.955 (2.3605 - 2.3604) | | |
| Grade No. X | 59.955 - 59.954 (2.3604 - 2.3604) | | |
| Grade No. Y | 59.954 - 59.953 (2.3604 - 2.3603) | | |
| Grade No. 4 | 59.953 - 59.952 (2.3603 - 2.3603) | | |
| Grade No. 7 | 59.952 - 59.951 (2.3603 - 2.3603) | | |
| Pin journal diameter. (Dp) grade | Standard | Grade No. 0 | 51.968 - 51.974 (2.0460 - 2.0462) |
| | | Grade No. 1 | 51.962 - 51.968 (2.0457 - 2.0460) |
| | | Grade No. 2 | 51.956 - 51.962 (2.0445 - 2.0457) |
| Center distance (r) | | | 40.66 - 40.74 (1.6008 - 1.6039) |
| Taper [Difference between (A) and (B)] | Limit | | Less than 0.002 (0.0001) |
| Out-of-round [Difference between (X) and (Y)] | | | Less than 0.002 (0.0001) |
| Crankshaft runout [TIR*] | Standard | | Less than 0.05 (0.0020) |
| | Limit | | 0.10 (0.0039) |
| Crankshaft end play | Standard | | 0.10 - 0.25 (0.0039 - 0.0098) |
| | Limit | | 0.30 (0.0118) |
| Fillet role of crankshaft journal | Standard | | More than 0.10 (0.0039) |

*: Total indicator reading

Main Bearing

INFOID:000000011148430

MAIN BEARING

Unit: mm (in)

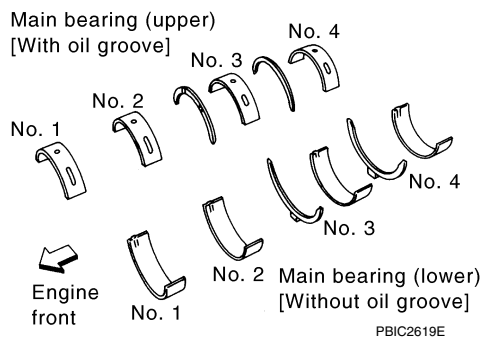

| Grade number* | Thickness | Width | Identification color | Remarks |
|---------------|-----------|-------|----------------------|---------|
|---------------|-----------|-------|----------------------|---------|

SERVICE DATA AND SPECIFICATIONS (SDS)

< SERVICE DATA AND SPECIFICATIONS (SDS)

| | | | | | |
|----|-----|---------------------------------|--------------------------------|--------|---|
| 0 | | 2.000 - 2.003 (0.0787 - 0.0789) | 19.9 - 20.1 (0.783 - 0.791) | Black | Grade is the same for upper and lower bearings. |
| 1 | | 2.003 - 2.006 (0.0789 - 0.0790) | | Brown | |
| 2 | | 2.006 - 2.009 (0.0790 - 0.0791) | | Green | |
| 3 | | 2.009 - 2.012 (0.0791 - 0.0792) | | Yellow | |
| 4 | | 2.012 - 2.015 (0.0792 - 0.0793) | | Blue | |
| 5 | | 2.015 - 2.018 (0.0793 - 0.0794) | | Pink | |
| 6 | | 2.018 - 2.021 (0.0794 - 0.0796) | | Purple | |
| 7 | | 2.021 - 2.024 (0.0796 - 0.0797) | | White | |
| 01 | UPR | 2.003 - 2.006 (0.0789 - 0.0790) | | Brown | |
| | LWR | 2.000 - 2.003 (0.0787 - 0.0789) | | Black | |
| 12 | UPR | 2.006 - 2.009 (0.0790 - 0.0791) | Green | | |
| | LWR | 2.003 - 2.006 (0.0789 - 0.0790) | Brown | | |
| 23 | UPR | 2.009 - 2.012 (0.0791 - 0.0792) | Yellow | | |
| | LWR | 2.006 - 2.009 (0.0790 - 0.0791) | Green | | |
| 34 | UPR | 2.012 - 2.015 (0.0792 - 0.0793) | Blue | | |
| | LWR | 2.009 - 2.012 (0.0791 - 0.0792) | Yellow | | |
| 45 | UPR | 2.015 - 2.018 (0.0793 - 0.0794) | Pink | | |
| | LWR | 2.012 - 2.015 (0.0792 - 0.0793) | Blue | | |
| 56 | UPR | 2.018 - 2.021 (0.0794 - 0.0796) | Purple | | |
| | LWR | 2.015 - 2.018 (0.0793 - 0.0794) | Pink | | |
| 67 | UPR | 2.021 - 2.024 (0.0796 - 0.0797) | White | | |
| | LWR | 2.018 - 2.021 (0.0794 - 0.0796) | Purple | | |

A
EM
C
D
E
F
G
H
I

*: Always check with the Parts Department for the latest parts information.

UNDERSIZE

Unit: mm (in)

| Items | Thickness | Main journal diameter |
|---------------|---------------------------------|---|
| 0.25 (0.0098) | 2.132 - 2.140 (0.0839 - 0.0843) | Grind so that bearing clearance is the specified value. |

MAIN BEARING OIL CLEARANCE

Unit: mm (in)

| Items | Standard | Limit |
|----------------------------|----------------------------------|----------------|
| Main bearing oil clearance | 0.035 - 0.045 (0.0014 - 0.0018)* | 0.065 (0.0026) |

*: Actual clearance

Connecting Rod Bearing

INFOID:000000011148431

CONNECTING ROD BEARING

Unit: mm (in)

| Grade number* | Thickness | Identification color (mark) |
|---------------|---------------------------------|-----------------------------|
| 0 | 1.500 - 1.503 (0.0591 - 0.0592) | Black |
| 1 | 1.503 - 1.506 (0.0592 - 0.0593) | Brown |
| 2 | 1.506 - 1.509 (0.0593 - 0.0594) | Green |

*: Always check with the Parts Department for the latest parts information.

UNDERSIZE

Unit: mm (in)

| Items | Thickness | Crank pin journal diameter (Dp) |
|---------------|---------------------------------|---|
| 0.25 (0.0098) | 1.626 - 1.634 (0.0640 - 0.0643) | Grind so that bearing clearance is the specified value. |

SERVICE DATA AND SPECIFICATIONS (SDS)

< SERVICE DATA AND SPECIFICATIONS (SDS)

CONNECTING ROD BEARING OIL CLEARANCE

Unit: mm (in)

| Items | Standard | Limit |
|--------------------------------------|----------------------------------|----------------|
| Connecting rod bearing oil clearance | 0.020 - 0.045 (0.0008 - 0.0018)* | 0.070 (0.0028) |

*: Actual clearance

Drive Plate

INFOID:000000011148432

Unit: mm (in)

| | |
|---|-------------------------|
| Drive plate runout [TIR]* - on torque converter mount surface | Less than 0.35 (0.0138) |
| Drive plate runout [TIR]* - on ring gear | 0.5 (0.0197) |

*: Total indicator reading