

SECTION **EXT**
EXTERIOR

A
B
C
D
E
F
G
H
I
J
EXT
L
M
N
O
P

CONTENTS

PRECAUTION	3	FENDER PROTECTOR	28
PRECAUTIONS	3	FENDER PROTECTOR	28
Precaution for Supplemental Restraint System (SRS) "AIR BAG" and "SEAT BELT PRE-TENSIONER"	3	FENDER PROTECTOR : Exploded View	28
Precaution for Procedure without Cowl Top Cover.....	3	FENDER PROTECTOR : Removal and Installation	28
Precaution for Work	3	REAR WHEEL HOUSE PROTECTOR	28
PREPARATION	5	REAR WHEEL HOUSE PROTECTOR : Exploded View	29
PREPARATION	5	REAR WHEEL HOUSE PROTECTOR : Removal and Installation	29
Special Service Tool	5	FRONT UNDER COVER	30
Commercial Service Tool	5	Exploded View	30
CLIP LIST	6	Removal and Installation	30
Descriptions for Clips	6	ROOF SIDE MOLDING	31
SYMPTOM DIAGNOSIS	10	Exploded View	31
SQUEAK AND RATTLE TROUBLE DIAGNOSES	10	Removal and Installation	31
Work Flow	10	DOOR OUTSIDE MOLDING	33
Generic Squeak and Rattle Troubleshooting	11	Exploded View	33
Diagnostic Worksheet	14	Removal and Installation	33
REMOVAL AND INSTALLATION	16	SIDE GUARD MOLDING	35
FRONT BUMPER	16	Exploded View	35
Exploded View	16	Removal and Installation	36
Removal and Installation	17	ROOF RACK	37
REAR BUMPER	20	Exploded View	37
Exploded View	20	Removal and Installation	37
Removal and Installation	20	DOOR OUTSIDE LOWER MOLDING	38
FRONT GRILLE	23	Exploded View	38
Exploded View	23	Removal and Installation	38
Removal and Installation	23	SILL MOLDING	40
COWL TOP	25	Exploded View	40
Exploded View	25	Removal and Installation	40
Removal and Installation	25	REAR SPOILER	41
		Exploded View	41

Removal and Installation	41	Exploded View	43
BACK DOOR OUTER FINISHER	43	Removal and Installation	43

PRECAUTIONS

< PRECAUTION >

PRECAUTION

PRECAUTIONS

Precaution for Supplemental Restraint System (SRS) "AIR BAG" and "SEAT BELT PRE-TENSIONER"

INFOID:000000011152166

The Supplemental Restraint System such as "AIR BAG" and "SEAT BELT PRE-TENSIONER", used along with a front seat belt, helps to reduce the risk or severity of injury to the driver and front passenger for certain types of collision. Information necessary to service the system safely is included in the SR and SB section of this Service Manual.

WARNING:

- To avoid rendering the SRS inoperative, which could increase the risk of personal injury or death in the event of a collision which would result in air bag inflation, all maintenance must be performed by an authorized NISSAN/INFINITI dealer.
- Improper maintenance, including incorrect removal and installation of the SRS, can lead to personal injury caused by unintentional activation of the system. For removal of Spiral Cable and Air Bag Module, see the SR section.
- Do not use electrical test equipment on any circuit related to the SRS unless instructed to in this Service Manual. SRS wiring harnesses can be identified by yellow and/or orange harnesses or harness connectors.

PRECAUTIONS WHEN USING POWER TOOLS (AIR OR ELECTRIC) AND HAMMERS

WARNING:

- When working near the Airbag Diagnosis Sensor Unit or other Airbag System sensors with the Ignition ON or engine running, DO NOT use air or electric power tools or strike near the sensor(s) with a hammer. Heavy vibration could activate the sensor(s) and deploy the air bag(s), possibly causing serious injury.
- When using air or electric power tools or hammers, always switch the Ignition OFF, disconnect the battery and wait at least three minutes before performing any service.

Precaution for Procedure without Cowl Top Cover

INFOID:000000011152167

When performing the procedure after removing cowl top cover, cover the lower end of windshield with urethane, etc to prevent damage to windshield.

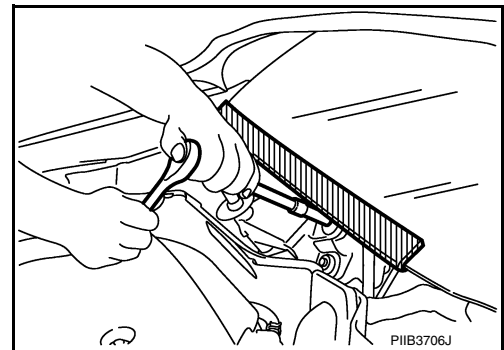

Precaution for Work

INFOID:000000011152168

- When removing or disassembling each component, be careful not to damage or deform it. If a component may be subject to interference, be sure to protect it with a shop cloth.
- When removing (disengaging) components with a screwdriver or similar tool, be sure to wrap the component with a shop cloth or vinyl tape to protect it.
- Protect the removed parts with a shop cloth and prevent them from being dropped.
- Replace a deformed or damaged clip.
- If a part is specified as a non-reusable part, always replace it with a new one.
- Be sure to tighten bolts and nuts securely to the specified torque.
- After installation is complete, be sure to check that each part works properly.
- Follow the steps below to clean components:
 - Water soluble dirt:
 - Dip a soft cloth into lukewarm water, wring the water out of the cloth and wipe the dirty area.
 - Then rub with a soft, dry cloth.
 - Oily dirt:

A

B

C

D

E

F

G

H

I

J

EXT

L

M

N

O

P

PRECAUTIONS

< PRECAUTION >

- Dip a soft cloth into lukewarm water with mild detergent (concentration: within 2 to 3%) and wipe the dirty area.
- Then dip a cloth into fresh water, wring the water out of the cloth and wipe the detergent off.
- Then rub with a soft, dry cloth.
- Do not use organic solvent such as thinner, benzene, alcohol or gasoline.
- For genuine leather seats, use a genuine leather seat cleaner.

PREPARATION

< PREPARATION >

PREPARATION

PREPARATION

Special Service Tool

INFOID:000000011152169

The actual shape of the tools may differ from those illustrated here.

Tool number (TechMate No.) Tool name	Description
— (J-39570) Chassis Ear	Locating the noise
— (J-50397) NISSAN Squeak and Rattle Kit	Repairing the cause of noise
— (J-46534) Trim Tool Set	Removing trim components

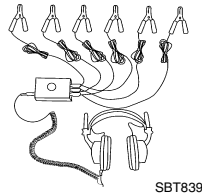

SBT839



ALJIA1232ZZ

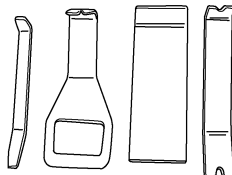

AWJIA0483ZZ

Commercial Service Tool

INFOID:000000011152170

(TechMate No.) Tool name	Description
(J-39565) Engine ear	Locating the noise

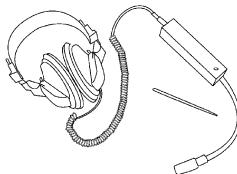

SIIA0995E

A
B
C
D
E
F
G
H
I
J
EXT
L
M
N
O
P

CLIP LIST







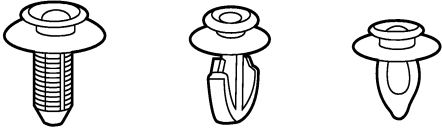

< PREPARATION >

CLIP LIST

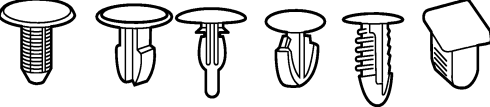
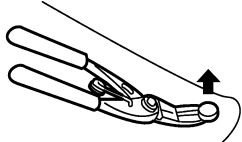
Descriptions for Clips

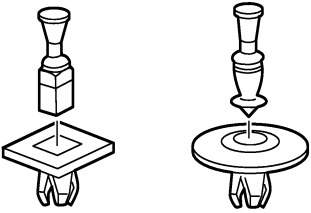
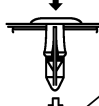
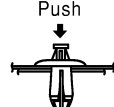
INFOID:000000011152171

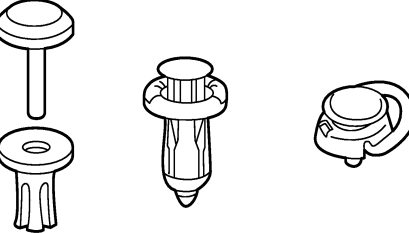
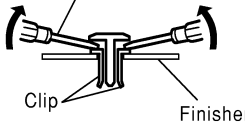

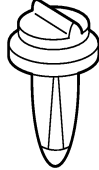
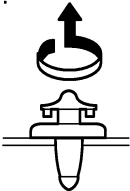





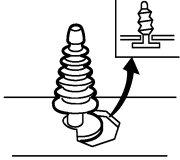
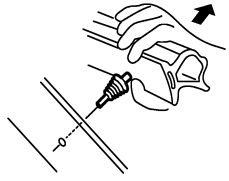

Replace any clips which are damaged during removal or installation.

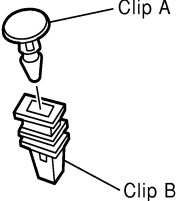
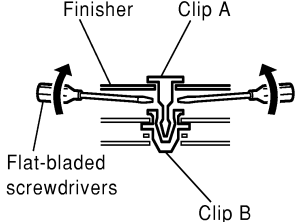
Symbol No.	Shapes	Removal & Installation
<p>C101</p> 		<p>Removal: Remove by bending up with flat-bladed screwdrivers or clip remover.</p> 
<p>C103</p> 		 <p>Removal: Remove with a clip remover.</p>
<p>C203</p> 		<p>Removal: Push center pin to catching position. (Do not remove center pin by hitting it.)</p> <p>Push</p>  <p>Installation:</p> 
<p>C205</p> 		<p>Removal:</p>  <p>Flat-bladed screwdriver</p> <p>Clip</p> <p>Finisher</p>
<p>C206</p> 		<p>Removal:</p> 

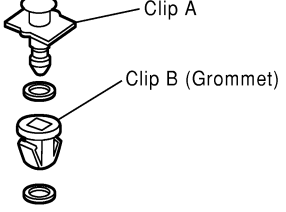
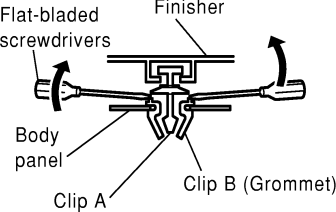
SIIA0315E

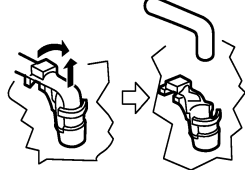
CLIP LIST

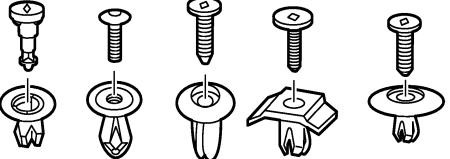
< PREPARATION >









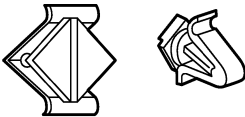

Symbol No.	Shapes	Removal & Installation
<p>CE103</p> 		<p>Removal:</p> 
<p>CF110</p> 		<p>Removal:</p> 
<p>CF118</p> 		<p>Removal:</p> 
<p>CR103</p> 		<p>Removal: Holder portion of clip must be spread out to remove rod.</p> 
<p>CS101</p> 		<p>Removal:</p> <ol style="list-style-type: none"> 1. Screw out with a Phillips screwdriver. 2. Remove female portion with flat-bladed screwdriver. 

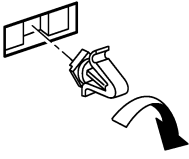
SIIA0316E

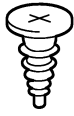
A
B
C
D
E
F
G
H
I
J
EXT
L
M
N
O
P

CLIP LIST

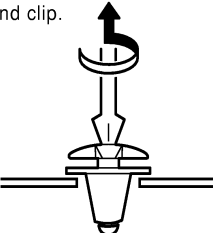

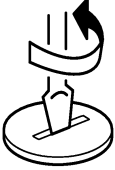
< PREPARATION >

Symbol No.	Shapes	Removal & Installation	
CG101 		Removal:  Rotate 45° to remove	Installation: 
CS102 			
CS113 		Removal: Disconnect upper connection of clip with a flat-bladed screwdriver, then remove clip while inserting a flat-bladed screwdriver between body panel and clip. 	
C111 			

SIIA0317E

CLIP LIST

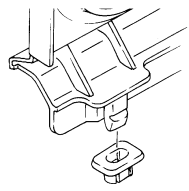
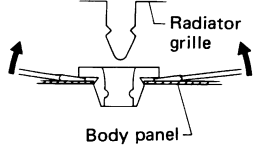
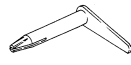
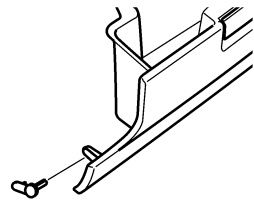
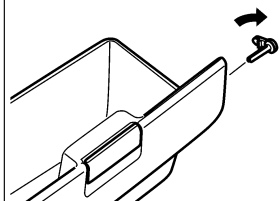
< PREPARATION >

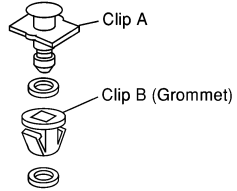
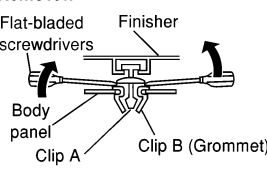
Symbol No.	Shapes	Removal & Installation
<p>CG104</p> 		<p>Removal: Remove by bending up with flat-bladed screwdrivers.</p> 
<p>CE114</p> 		
<p>CF118</p> 		<p>Removal: Flat-bladed screwdrivers</p> 

ALJIA0564GB

A
B
C
D
E
F
G
H
I
J
L
M
N
O
P

EXT

SQUEAK AND RATTLE TROUBLE DIAGNOSES

< SYMPTOM DIAGNOSIS >

SYMPTOM DIAGNOSIS

SQUEAK AND RATTLE TROUBLE DIAGNOSES

Work Flow

INFOID:000000011152172

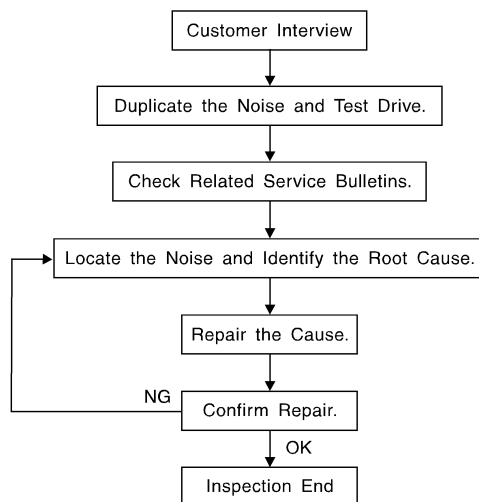

SBT842

CUSTOMER INTERVIEW

Interview the customer if possible, to determine the conditions that exist when the noise occurs. Use the Diagnostic Worksheet during the interview to document the facts and conditions when the noise occurs and any customer's comments; refer to [EXT-14, "Diagnostic Worksheet"](#). This information is necessary to duplicate the conditions that exist when the noise occurs.

- The customer may not be able to provide a detailed description or the location of the noise. Attempt to obtain all the facts and conditions that exist when the noise occurs (or does not occur).
- If there is more than one noise in the vehicle, be sure to diagnose and repair the noise that the customer is concerned about. This can be accomplished by test driving the vehicle with the customer.
- After identifying the type of noise, isolate the noise in terms of its characteristics. The noise characteristics are provided so the customer, service adviser and technician are all speaking the same language when defining the noise.
- Squeak —(Like tennis shoes on a clean floor)
Squeak characteristics include the light contact/fast movement/brought on by road conditions/hard surfaces = higher pitch noise/softer surfaces = lower pitch noises/edge to surface = chirping.
- Creak—(Like walking on an old wooden floor)
Creak characteristics include firm contact/slow movement/twisting with a rotational movement/pitch dependent on materials/often brought on by activity.
- Rattle—(Like shaking a baby rattle)
Rattle characteristics include the fast repeated contact/vibration or similar movement/loose parts/missing clip or fastener/incorrect clearance.
- Knock —(Like a knock on a door)
Knock characteristics include hollow sounding/sometimes repeating/often brought on by driver action.
- Tick—(Like a clock second hand)
Tick characteristics include gentle contacting of light materials/loose components/can be caused by driver action or road conditions.
- Thump—(Heavy, muffled knock noise)
Thump characteristics include softer knock/dead sound often brought on by activity.
- Buzz—(Like a bumble bee)
Buzz characteristics include high frequency rattle/firm contact.
- Often the degree of acceptable noise level will vary depending upon the person. A noise that you may judge as acceptable may be very irritating to the customer.
- Weather conditions, especially humidity and temperature, may have a great effect on noise level.

DUPLICATE THE NOISE AND TEST DRIVE

SQUEAK AND RATTLE TROUBLE DIAGNOSES

< SYMPTOM DIAGNOSIS >

If possible, drive the vehicle with the customer until the noise is duplicated. Note any additional information on the Diagnostic Worksheet regarding the conditions or location of the noise. This information can be used to duplicate the same conditions when you confirm the repair.

If the noise can be duplicated easily during the test drive, to help identify the source of the noise, try to duplicate the noise with the vehicle stopped by doing one or all of the following:

- 1) Close a door.
 - 2) Tap or push/pull around the area where the noise appears to be coming from.
 - 3) Rev the engine.
 - 4) Use a floor jack to recreate vehicle "twist".
 - 5) At idle, apply engine load (electrical load, half-clutch on M/T model, drive position on CVT and A/T models).
 - 6) Raise the vehicle on a hoist and hit a tire with a rubber hammer.
- Drive the vehicle and attempt to duplicate the conditions the customer states exist when the noise occurs.
 - If it is difficult to duplicate the noise, drive the vehicle slowly on an undulating or rough road to stress the vehicle body.

CHECK RELATED SERVICE BULLETINS

After verifying the customer concern or symptom, check ASIST for Technical Service Bulletins (TSBs) related to that concern or symptom.

If a TSB relates to the symptom, follow the procedure to repair the noise.

LOCATE THE NOISE AND IDENTIFY THE ROOT CAUSE

1. Narrow down the noise to a general area. To help pinpoint the source of the noise, use a listening tool (Chassis Ear: J-39570, Engine Ear: J-39565 and mechanic's stethoscope).
2. Narrow down the noise to a more specific area and identify the cause of the noise by:
 - removing the components in the area that you suspect the noise is coming from.
Do not use too much force when removing clips and fasteners, otherwise clips and fasteners can be broken or lost during the repair, resulting in the creation of new noise.
 - tapping or pushing/pulling the component that you suspect is causing the noise.
Do not tap or push/pull the component with excessive force, otherwise the noise will be eliminated only temporarily.
 - feeling for a vibration with your hand by touching the component(s) that you suspect is (are) causing the noise.
 - placing a piece of paper between components that you suspect are causing the noise.
 - looking for loose components and contact marks.Refer to [EXT-11. "Generic Squeak and Rattle Troubleshooting"](#).

REPAIR THE CAUSE

- If the cause is a loose component, tighten the component securely.
- If the cause is insufficient clearance between components:
 - separate components by repositioning or loosening and retightening the component, if possible.
 - insulate components with a suitable insulator such as urethane pads, foam blocks, felt cloth tape or urethane tape. A NISSAN Squeak and Rattle Kit (J-50397) is available through your authorized NISSAN Parts Department.

CAUTION:

Do not use excessive force as many components are constructed of plastic and may be damaged.

NOTE:

- Always check with the Parts Department for the latest parts information.
- The materials contained in the NISSAN Squeak and Rattle Kit (J-50397) are listed on the inside cover of the kit; and can each be ordered separately as needed.
- The following materials not found in the kit can also be used to repair squeaks and rattles.
 - SILICONE GREASE: Use instead of UHMW tape that will be visible or does not fit. The silicone grease will only last a few months.
 - SILICONE SPRAY: Use when grease cannot be applied.
 - DUCT TAPE: Use to eliminate movement.

CONFIRM THE REPAIR

Confirm that the cause of a noise is repaired by test driving the vehicle. Operate the vehicle under the same conditions as when the noise originally occurred. Refer to the notes on the Diagnostic Worksheet.

Generic Squeak and Rattle Troubleshooting

INFOID:000000011152173

Refer to Table of Contents for specific component removal and installation information.

SQUEAK AND RATTLE TROUBLE DIAGNOSES

< SYMPTOM DIAGNOSIS >

INSTRUMENT PANEL

Most incidents are caused by contact and movement between:

1. Cluster lid A and the instrument panel
2. Acrylic lens and combination meter housing
3. Instrument panel to front pillar finisher
4. Instrument panel to windshield
5. Instrument panel pins
6. Wiring harnesses behind the combination meter
7. A/C defroster duct and duct joint

These incidents can usually be located by tapping or moving the components to duplicate the noise or by pressing on the components while driving to stop the noise. Most of these incidents can be repaired by applying felt cloth tape or silicone spray (in hard to reach areas). Urethane pads can be used to insulate wiring harness.

CAUTION:

Do not use silicone spray to isolate a squeak or rattle. If you saturate the area with silicone, you will not be able to recheck the repair.

CENTER CONSOLE

Components to pay attention to include:

1. Shift selector assembly cover to finisher
2. A/C control unit and cluster lid C
3. Wiring harnesses behind audio and A/C control unit

The instrument panel repair and isolation procedures also apply to the center console.

DOORS

Pay attention to the:

1. Finisher and inner panel making a slapping noise
2. Inside handle escutcheon to door finisher
3. Wiring harnesses tapping
4. Door striker out of alignment causing a popping noise on starts and stops

Tapping or moving the components or pressing on them while driving to duplicate the conditions can isolate many of these incidents. You can usually insulate the areas with felt cloth tape or insulator foam blocks from the NISSAN Squeak and Rattle Kit (J-50397) to repair the noise.

TRUNK

Trunk noises are often caused by a loose jack or loose items put into the trunk by the owner.

In addition look for:

1. Trunk lid bumpers out of adjustment
2. Trunk lid striker out of adjustment
3. The trunk lid torsion bars knocking together
4. A loose license plate or bracket

Most of these incidents can be repaired by adjusting, securing or insulating the item(s) or component(s) causing the noise.

SUNROOF/HEADLINING

Noises in the sunroof/headlining area can often be traced to one of the following:

1. Sunroof lid, rail, linkage or seals making a rattle or light knocking noise
2. Sun visor shaft shaking in the holder
3. Front or rear windshield touching headlining and squeaking

Again, pressing on the components to stop the noise while duplicating the conditions can isolate most of these incidents. Repairs usually consist of insulating with felt cloth tape.

OVERHEAD CONSOLE (FRONT AND REAR)

Overhead console noises are often caused by the console panel clips not being engaged correctly. Most of these incidents are repaired by pushing up on the console at the clip locations until the clips engage.

In addition look for:

SQUEAK AND RATTLE TROUBLE DIAGNOSES

< SYMPTOM DIAGNOSIS >

1. Loose harness or harness connectors.
2. Front console map/reading lamp lens loose.
3. Loose screws at console attachment points.

A

SEATS

When isolating seat noise it's important to note the position the seat is in and the load placed on the seat when the noise is present. These conditions should be duplicated when verifying and isolating the cause of the noise.

B

Cause of seat noise include:

C

1. Headrest rods and holder
2. A squeak between the seat pad cushion and frame
3. The rear seatback lock and bracket

D

These noises can be isolated by moving or pressing on the suspected components while duplicating the conditions under which the noise occurs. Most of these incidents can be repaired by repositioning the component or applying urethane tape to the contact area.

E

UNDERHOOD

Some interior noise may be caused by components under the hood or on the engine wall. The noise is then transmitted into the passenger compartment.

F

Causes of transmitted underhood noise include:

1. Any component installed to the engine wall
2. Components that pass through the engine wall
3. Engine wall mounts and connectors
4. Loose radiator installation pins
5. Hood bumpers out of adjustment
6. Hood striker out of adjustment

G

H

These noises can be difficult to isolate since they cannot be reached from the interior of the vehicle. The best method is to secure, move or insulate one component at a time and test drive the vehicle. Also, engine rpm or load can be changed to isolate the noise. Repairs can usually be made by moving, adjusting, securing, or insulating the component causing the noise.

I

J

EXT

L

M

N

O

P

SQUEAK AND RATTLE TROUBLE DIAGNOSES

< SYMPTOM DIAGNOSIS >

Diagnostic Worksheet

INFOID:000000011152174

Dear Customer:

We are concerned about your satisfaction with your vehicle. Repairing a squeak or rattle sometimes can be very difficult. To help us fix your vehicle right the first time, please take a moment to note the area of the vehicle where the squeak or rattle occurs and under what conditions. You may be asked to take a test drive with a service advisor or technician to ensure we confirm the noise you are hearing.

SQUEAK & RATTLE DIAGNOSTIC WORKSHEET

I. WHERE DOES THE NOISE COME FROM? (circle the area of the vehicle)

The illustrations are for reference only, and may not reflect the actual configuration of your vehicle.

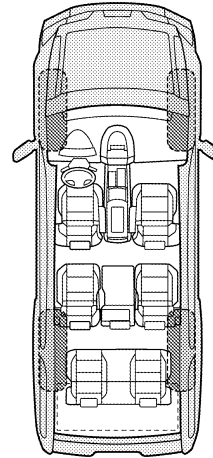
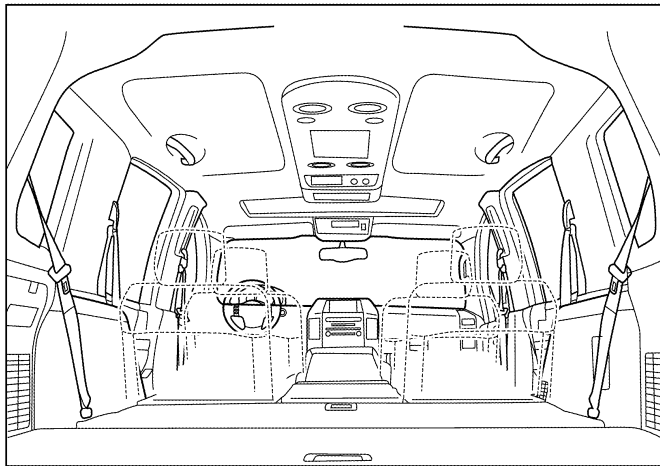
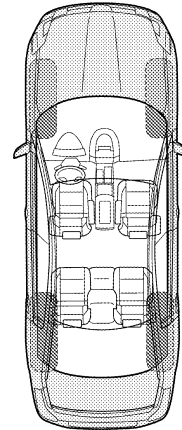
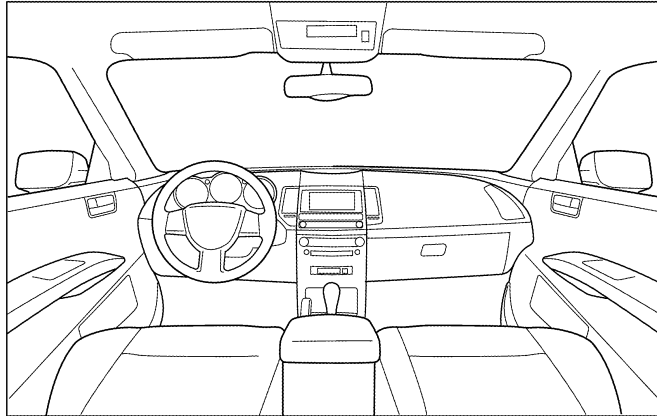

Continue to page 2 of the worksheet and briefly describe the location of the noise or rattle. In addition, please indicate the conditions which are present when the noise occurs.

SQUEAK AND RATTLE TROUBLE DIAGNOSES

< SYMPTOM DIAGNOSIS >

SQUEAK & RATTLE DIAGNOSTIC WORKSHEET - page 2

Briefly describe the location where the noise occurs:

II. WHEN DOES IT OCCUR? (please check the boxes that apply)

- | | |
|---|--|
| <input type="checkbox"/> Anytime | <input type="checkbox"/> After sitting out in the rain |
| <input type="checkbox"/> 1st time in the morning | <input type="checkbox"/> When it is raining or wet |
| <input type="checkbox"/> Only when it is cold outside | <input type="checkbox"/> Dry or dusty conditions |
| <input type="checkbox"/> Only when it is hot outside | <input type="checkbox"/> Other: |

III. WHEN DRIVING:

- Through driveways
- Over rough roads
- Over speed bumps
- Only about ____ mph
- On acceleration
- Coming to a stop
- On turns: left, right or either (circle)
- With passengers or cargo
- Other: _____
- After driving ____ miles or ____ minutes

IV. WHAT TYPE OF NOISE

- Squeak (like tennis shoes on a clean floor)
- Creak (like walking on an old wooden floor)
- Rattle (like shaking a baby rattle)
- Knock (like a knock at the door)
- Tick (like a clock second hand)
- Thump (heavy muffled knock noise)
- Buzz (like a bumble bee)

TO BE COMPLETED BY DEALERSHIP PERSONNEL

Test Drive Notes:

	YES	NO	Initials of person performing
Vehicle test driven with customer	<input type="checkbox"/>	<input type="checkbox"/>	_____
- Noise verified on test drive	<input type="checkbox"/>	<input type="checkbox"/>	_____
- Noise source located and repaired	<input type="checkbox"/>	<input type="checkbox"/>	_____
- Follow up test drive performed to confirm repair	<input type="checkbox"/>	<input type="checkbox"/>	_____

VIN: _____ Customer Name _____
W.O.# _____ Date: _____

This form must be attached to Work Order

LAI/A0071E

A
B
C
D
E
F
G
H
I
J
L
M
N
O
P

EXT

FRONT BUMPER

< REMOVAL AND INSTALLATION >

REMOVAL AND INSTALLATION

FRONT BUMPER

Exploded View

INFOID:000000011152175

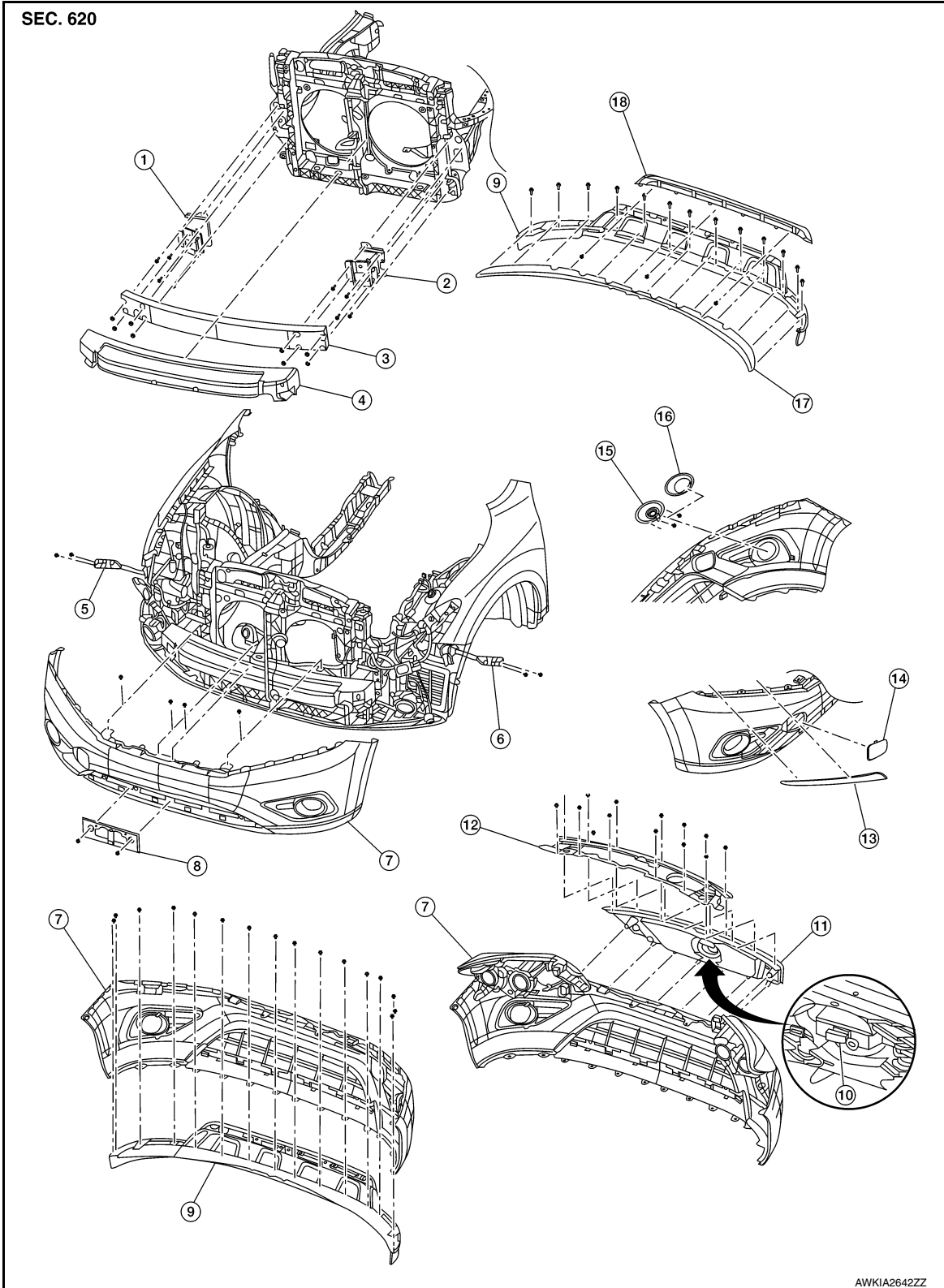

FRONT BUMPER

< REMOVAL AND INSTALLATION >

- | | | |
|--|--|--|
| 1. Front bumper reinforcement support (RH) | 2. Front bumper reinforcement support (LH) | 3. Front bumper reinforcement support (RH) |
| 4. Front energy absorber | 5. Front bumper side bracket (RH) | 6. Front bumper side bracket (LH) |
| 7. Front bumper fascia | 8. Front license plate bracket | 9. Front air spoiler (upper) |
| 10. Front camera (if equipped) | 11. Front grille | 12. Core support cover |
| 13. Front fascia (side) molding | 14. Tow cover | 15. Front fascia finisher |
| 16. Front fog lamp finisher (if equipped) | 17. Front air spoiler (lower) | 18. Front fascia (center) molding |

Removal and Installation

INFOID:000000011152176

REMOVAL

CAUTION:

Bumper fascia is made of resin. Use care when handling to prevent damage. Avoid contact with oily substances.

1. Open hood.
2. Remove the core support cover clips (A) and the core support cover.

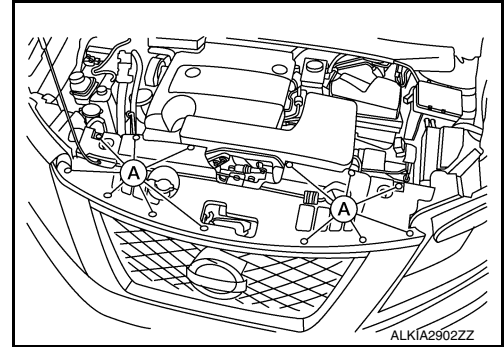

3. Partially remove the front fender protectors (LH/RH). Refer to [EXT-28. "FENDER PROTECTOR : Removal and Installation"](#).
4. Remove the front grille. Refer to [EXT-23. "Removal and Installation"](#).
NOTE:
Calibration must be performed after removing/replacing the camera. Refer to [AV-308. "CALIBRATING CAMERA IMAGE \(AROUND VIEW MONITOR\) : Work Procedure"](#).
5. Remove the front bumper fascia clips (A).

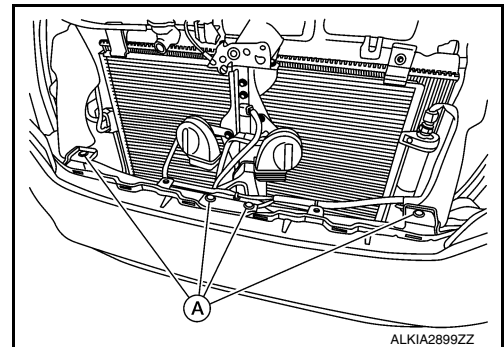

FRONT BUMPER

< REMOVAL AND INSTALLATION >

6. Remove the front bumper fascia to fender screw (A) (LH/RH).

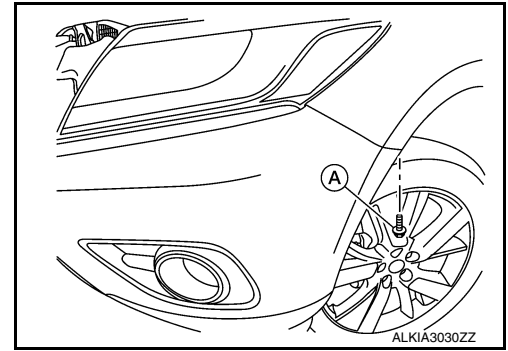

7. Disconnect the harness connectors from the fog lamps (LH/RH) (if equipped).

8. Release the front bumper fascia pawls from the side brackets (LH/RH) as shown.

CAUTION:

When removing front bumper fascia, two people are required to avoid damaging.

○: Pawl

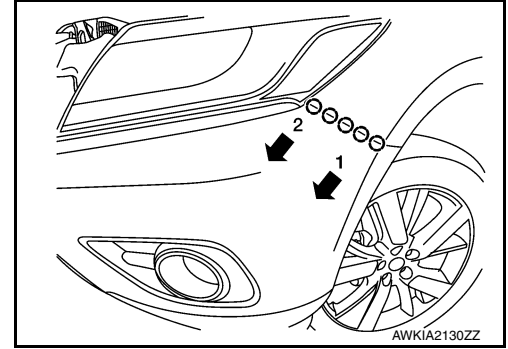

9. Remove the front bumper fascia.

10. Remove the following parts (if necessary) after removing front bumper fascia.

- Front air spoiler.
- Front fog lamp assemblies (LH/RH) (if equipped). Refer to [EXL-148. "Removal and Installation"](#).
- Front license plate bracket. Refer to [EXT-16. "Exploded View"](#)

11. Remove the front bumper fascia upper retainer bracket and remove front bumper fascia .

INSTALLATION

Installation is in the reverse order of removal.

NOTE:

- The following table shows the specified values for checking normal installation status.
- Fitting adjustment cannot be performed.

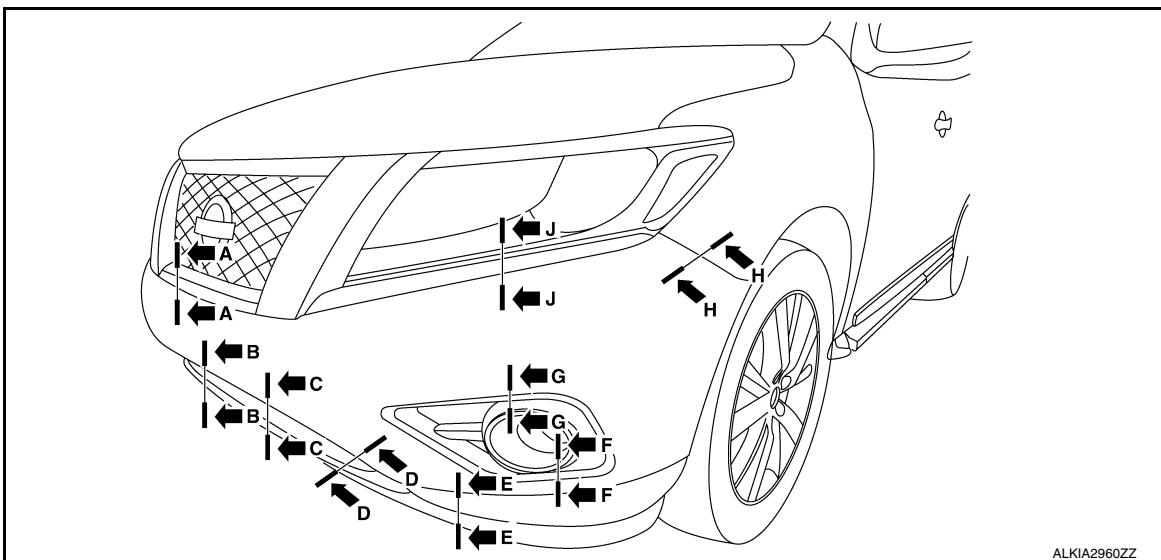

Unit: mm (in)

FRONT BUMPER

< REMOVAL AND INSTALLATION >

Section	Measurement	Minimum	Target Value	Maximum
A-A	Clearance	0.2 (0.01)	1.5 (0.06)	2.8 (0.11)
B-B	Clearance	0.5 (0.02)	2.0 (0.08)	3.5 (0.14)
B-B	Surface height	0.0 (0.00)	1.4 (0.06)	2.8 (0.11)
C-C	Clearance	1.0 (0.04)	2.0 (0.08)	3.0 (0.12)
C-C	Surface height	0.0 (0.00)	1.0 (0.04)	2.0 (0.08)
D-D	Clearance	0.0 (0.00)	0.0 (0.00)	0.0 (0.00)
D-D	Surface height	0.0 (0.00)	0.0 (0.00)	0.0 (0.00)
E-E	Clearance	0.0 (0.00)	0.0 (0.00)	0.7 (0.03)
F-F	Clearance	0.7 (0.03)	2.0 (0.08)	3.3 (0.13)
G-G	Clearance	0.0 (0.00)	0.0 (0.00)	1.0 (0.04)
H-H	Clearance	0.0 (0.00)	0.0 (0.00)	0.8 (0.03)
H-H	Surface height	-0.3 (-0.01)	0.7 (0.03)	1.7 (0.07)
J-J	Clearance	0.5 (0.02)	1.5 (0.06)	2.5 (0.10)

A
B
C
D
E
F
G
H
I
J
L
M
N
O
P

EXT

REAR BUMPER

< REMOVAL AND INSTALLATION >

REAR BUMPER

Exploded View

INFOID:000000011152177

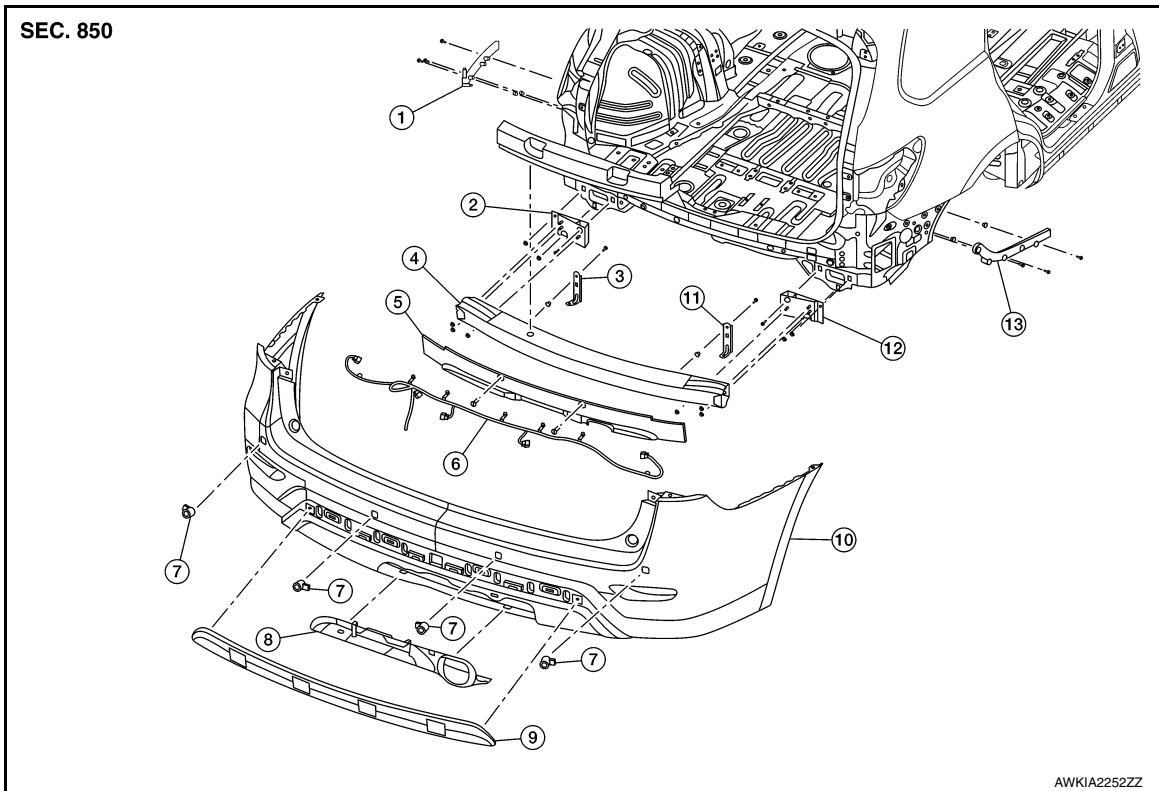

- | | | |
|-----------------------------------|---|--|
| 1. Rear bumper side bracket (LH) | 2. Rear bumper reinforcement support (LH) | 3. Rear bumper fascia lower bracket (LH) |
| 4. Rear bumper reinforcement | 5. Rear bumper energy absorber | 6. Rear sonar sensor harness (if equipped) |
| 7. Sonar sensors (if equipped) | 8. Tow hitch finisher | 9. Rear bumper fascia molding |
| 10. Rear bumper fascia | 11. Rear bumper fascia lower bracket (RH) | 12. Rear bumper reinforcement support (RH) |
| 13. Rear bumper side bracket (RH) | | |

Removal and Installation

INFOID:000000011152178

REMOVAL

CAUTION:

Bumper fascia is made of resin. Use care when handling to prevent damage. Avoid contact with oily substances.

1. Open back door.
2. Remove the rear combination lamps (LH/RH). Refer to [EXL-153, "Removal and Installation"](#).

REAR BUMPER

< REMOVAL AND INSTALLATION >

3. Remove the rear bumper fascia clips (A) and screws (B) (LH/RH).

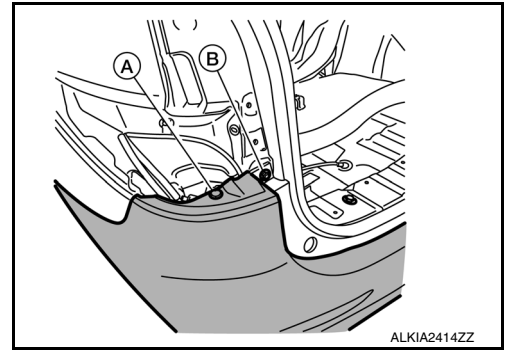

4. Partially remove the rear wheel house protectors. Refer to [EXT-29. "REAR WHEEL HOUSE PROTECTOR : Removal and Installation"](#).

5. Remove the bumper fascia side upper screws (A) (LH/RH).



6. Remove rear bumper fascia lower side bolts (A) (LH/RH).

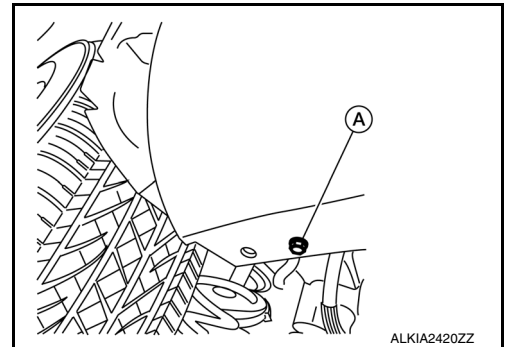

7. Remove the rear bumper fascia lower rear clips (A).

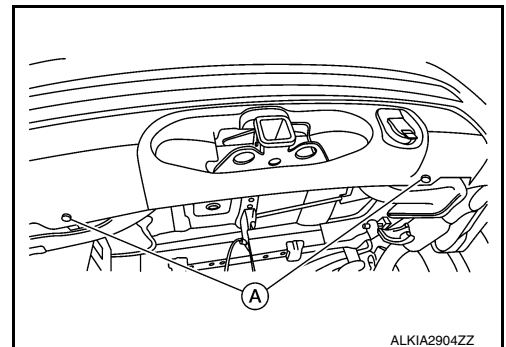

8. Disconnect the harness connector from rear sonar sensors (if equipped).

A
B
C
D
E
F
G
H
I
J
EXT
L
M
N
O
P

REAR BUMPER

< REMOVAL AND INSTALLATION >

9. Pull rear bumper fascia outward away from vehicle to release from rear bumper side brackets (LH/RH).

⊖: Pawl

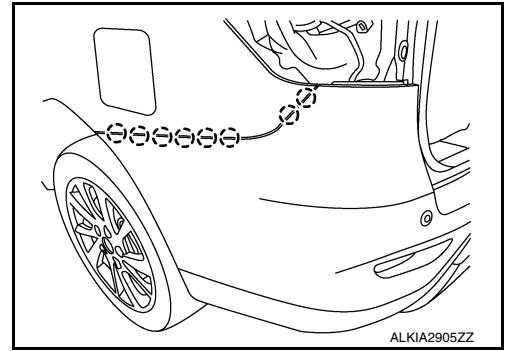

10. Remove the rear bumper fascia.

CAUTION:

When removing rear bumper fascia, two people are required to avoid damaging.

11. Remove the following parts (if necessary) after removing rear bumper fascia.

- Rear bumper side brackets (LH/RH)
- Rear bumper fascia reflectors (LH/RH)
- Rear sonar sensors (if equipped)
- Rear bumper fascia molding
- Tow hitch finisher (if equipped)

12. Remove rear bumper energy absorber.

INSTALLATION

Installation is in the reverse order of removal.

NOTE:

- The following table shows the specified values for checking normal installation status.
- Fitting adjustment cannot be performed.

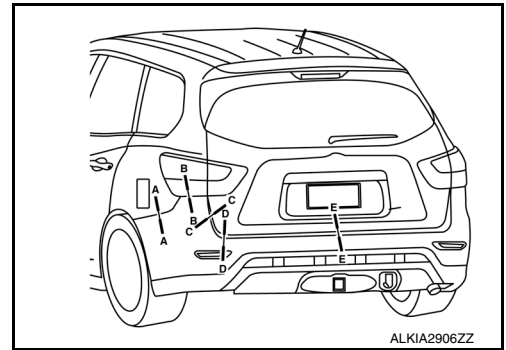

mm (in)

Section	Measurement	Minimum	Target Value	Maximum
A-A	Clearance	0.0 (0.00)	1.0 (0.04)	2.0 (0.08)
B-B	Clearance	0.0 (0.00)	1.5 (0.06)	3.0 (0.12)
C-C	Clearance	3.0 (0.12)	5.0 (0.20)	7.0 (0.28)
C-C	Surface height	-1.0 (-0.04)	1.0 (0.04)	3.0 (0.12)
D-D	Clearance	-1.0 (-0.04)	0.0 (0.00)	1.0 (0.04)
D-D	Surface height	-0.2 (0.01)	0.8 (0.03)	1.8 (0.07)
E-E	Clearance	5.0 (0.12)	7.0 (0.28)	9.0 (0.35)

FRONT GRILLE

< REMOVAL AND INSTALLATION >

FRONT GRILLE

Exploded View

INFOID:000000011152179

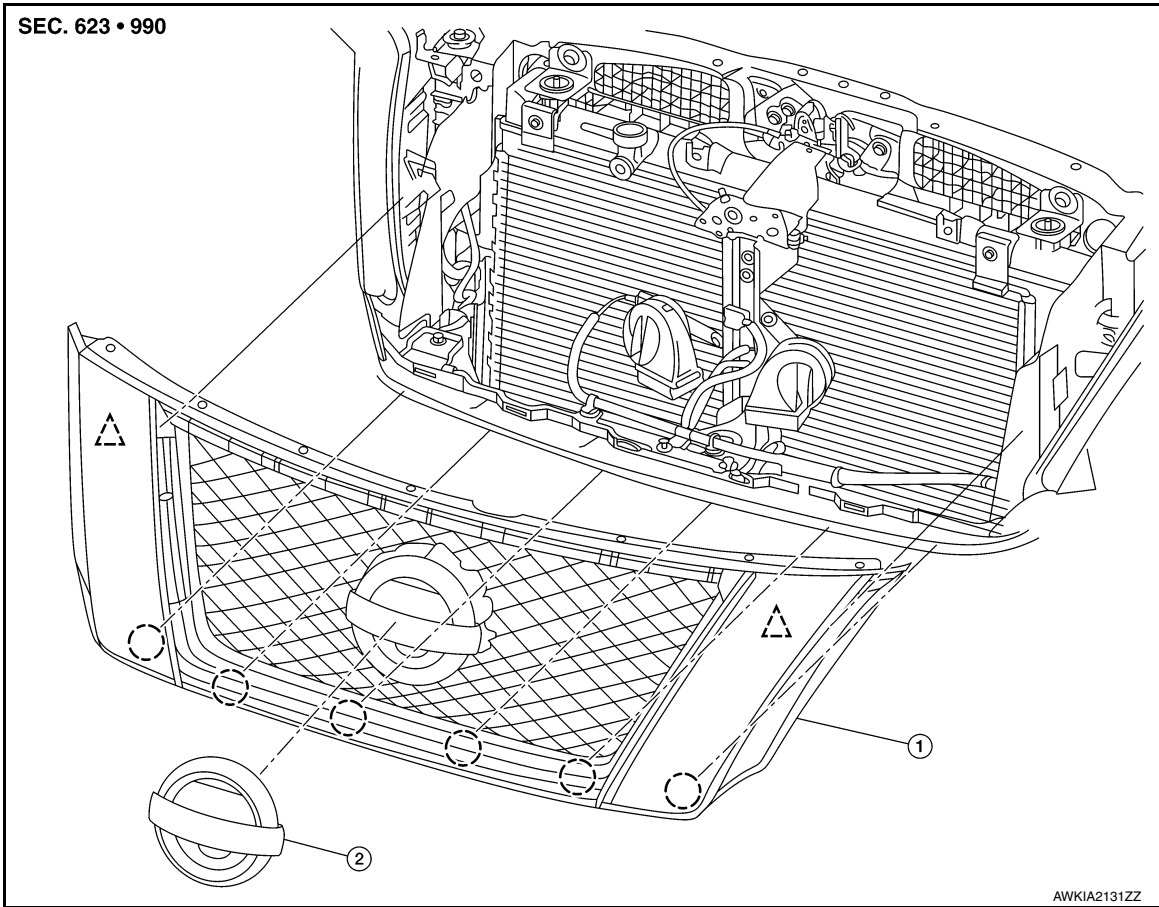

1. Front grille

2. Front emblem

○ Pawl

△ Clip

Removal and Installation

INFOID:000000011152180

REMOVAL

1. Open hood.
2. Remove core support cover. Refer to [EXT-17. "Removal and Installation"](#).
3. Disconnect the harness connector (A) from front camera (if equipped).

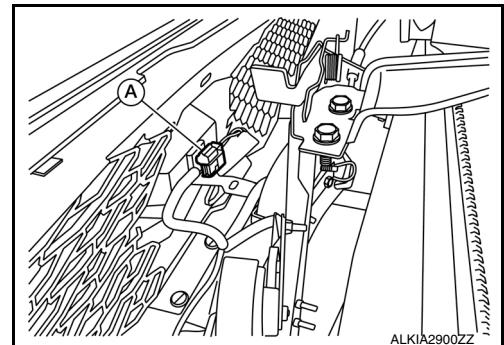

FRONT GRILLE

< REMOVAL AND INSTALLATION >

4. Release the front grille clip (A) (LH/RH).
5. Release the pawls and remove the front grille.

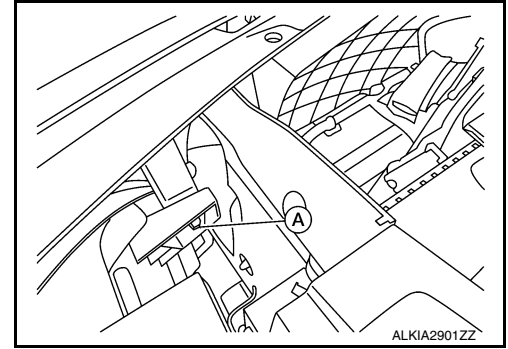

6. Remove the front emblem and front camera (if equipped) from front grille. Refer to [AV-444. "Removal and Installation"](#).

INSTALLATION

Installation is in the reverse order of removal.

COWL TOP

< REMOVAL AND INSTALLATION >

COWL TOP

Exploded View

INFOID:0000000011152181

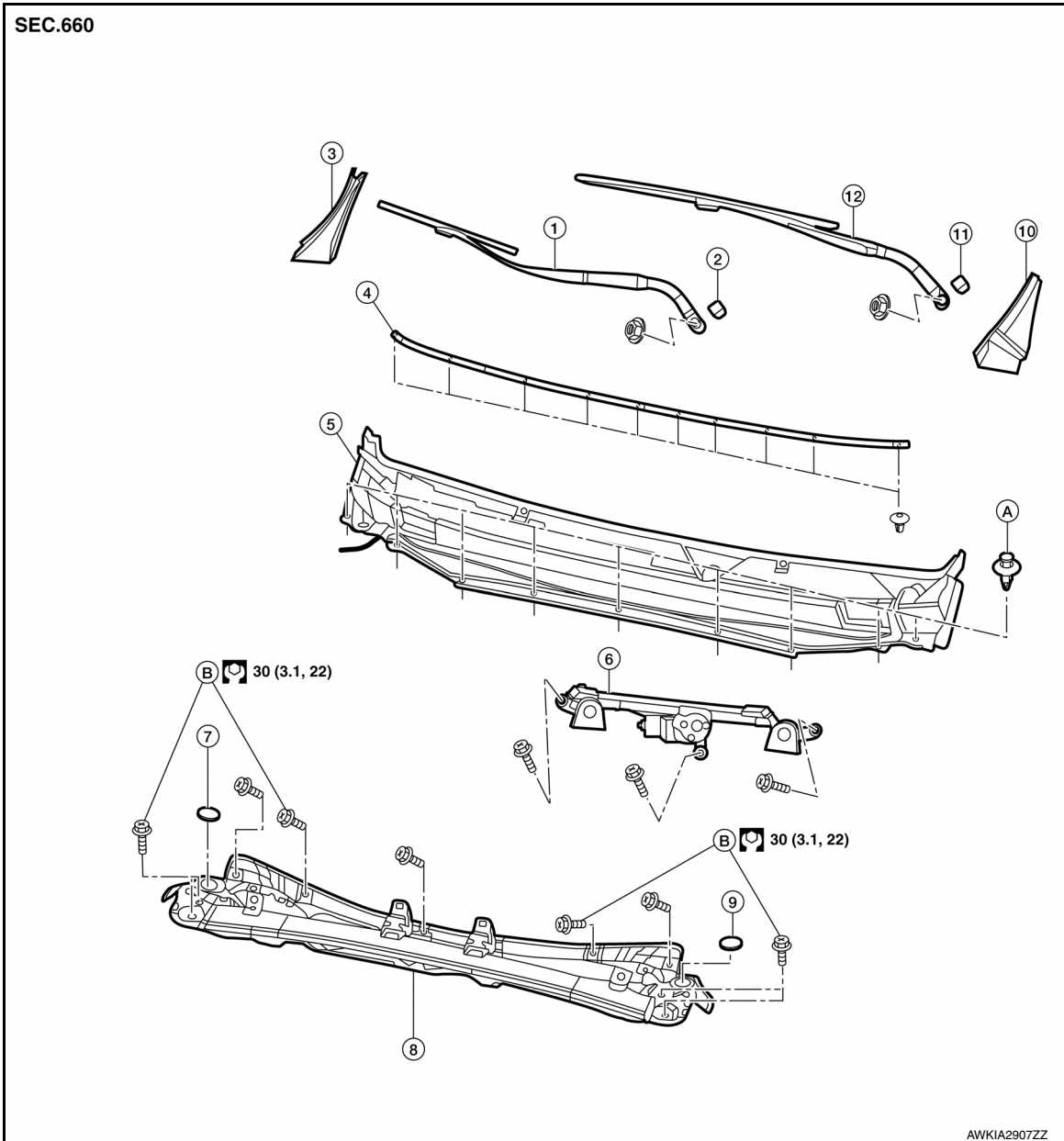

- | | | |
|--------------------------------------|--------------------------|---------------------------------------|
| 1. Wiper arm and blade assembly (RH) | 2. Wiper arm cap (RH) | 3. Cowl top side trim cover (RH) |
| 4. Cowl top seal | 5. Cowl top cover | 6. Front wiper drive assembly |
| 7. Rubber plug (RH) | 8. Cowl top extension | 9. Rubber plug (LH) |
| 10. Cowl top side trim cover (LH) | 11. Wiper arm cap (LH) | 12. Wiper arm and blade assembly (LH) |
| A. Clip | B. Refer to installation | |

Removal and Installation

INFOID:0000000011152182

COWL TOP COVER

Removal

1. Remove front wiper arms (LH/RH). Refer to [WW-62. "Removal and Installation"](#).

A
B
C
D
E
F
G
H
I
J
EXT
L
M
N
O
P

COWL TOP

< REMOVAL AND INSTALLATION >

2. Release the cowl top seal clips and remove.
3. Release pawls using a suitable tool and remove hood ledge finisher (1).

○: Pawl

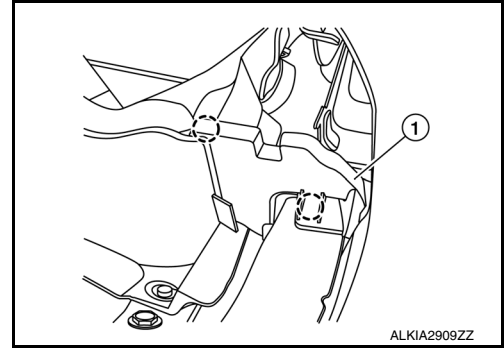

4. Release the pawls, then remove cowl top side trim covers (1) (LH/RH).

○: Pawl

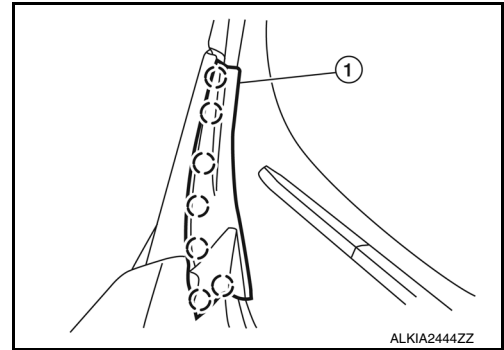

5. Disconnect front washer tube connector.
6. Remove cowl top cover clips.
7. Pull forward to release cowl top cover (1) and remove.

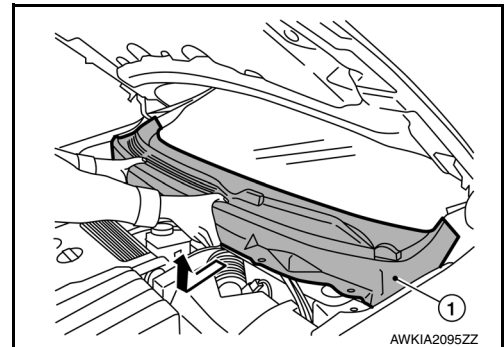

8. Remove the following parts after removing cowl top cover.
 - Front washer nozzle (LH/RH)
 - Front washer tube

Installation

Installation is in the reverse order of removal.

COWL TOP EXTENSION

Removal

1. Remove the front wiper drive assembly. Refer to [WW-65. "Removal and Installation"](#).

CAUTION:

When performing any procedure after removing cowl top cover, cover the lower end of windshield glass with urethane etc.

COWL TOP

< REMOVAL AND INSTALLATION >

2. Remove the brake reservoir bracket nuts (A), release the brake level sensor harness clips (B) and position the brake reservoir (1) aside.

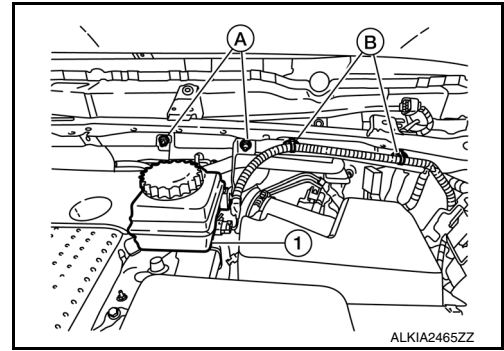

3. Remove the fuse and relay box nuts (A) and position the fuse and relay box (1) aside.

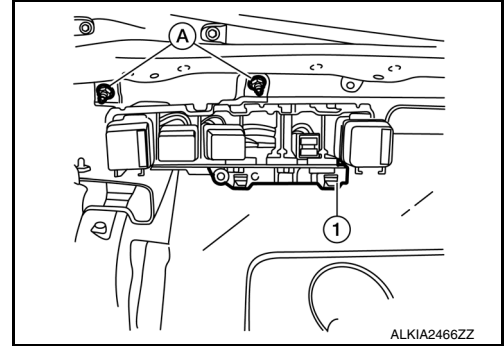

4. Remove the cowl top extension bolts and the cowl top extension.

INSTALLATION

Installation is in the reverse order of removal.

CAUTION:

- When installing cowl top cover, check that clips are securely placed in panel holes on body and then press them in.
- After installing, perform adjustment of wiper arms. Refer to [WW-62, "Removal and Installation"](#).

NOTE:

When installing the cowl top extension, tighten the bolts in the order shown.

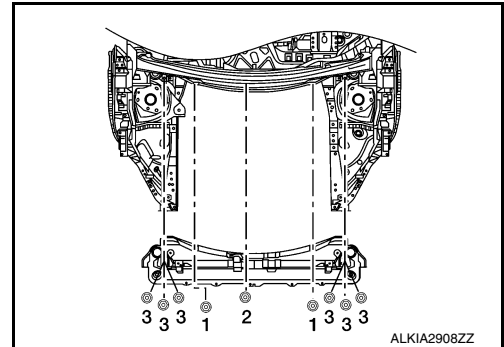

A
B
C
D
E
F
G
H
I
J
EXT
L
M
N
O
P

FENDER PROTECTOR

< REMOVAL AND INSTALLATION >

FENDER PROTECTOR

FENDER PROTECTOR

FENDER PROTECTOR : Exploded View

INFOID:000000011152183

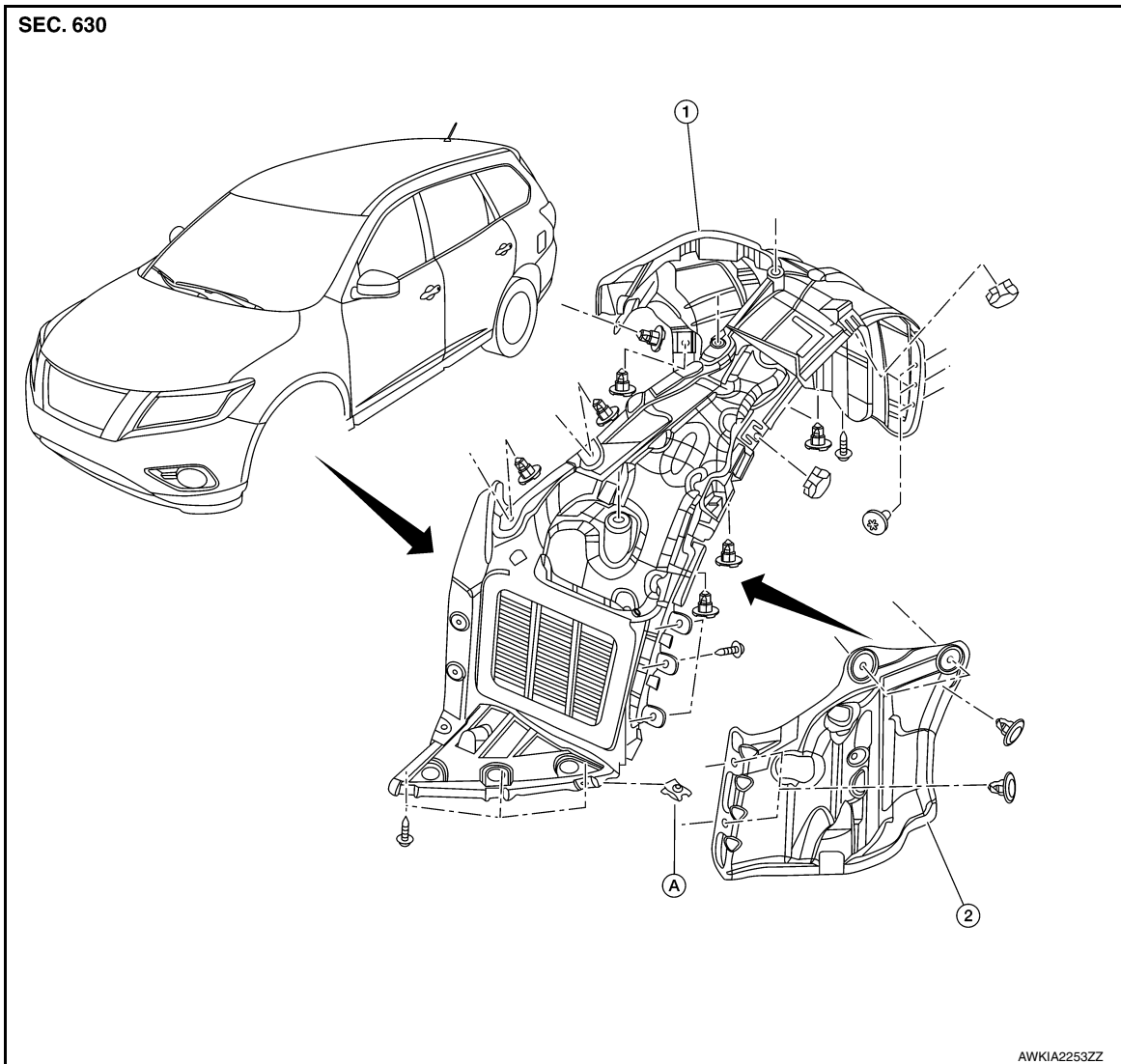

1. Front fender protector 2. Front fender protector side cover A. J-nut

FENDER PROTECTOR : Removal and Installation

INFOID:000000011152184

REMOVAL

1. Remove the front under cover. Refer to [EXT-30, "Removal and Installation"](#).
2. Position the front wheels as necessary to remove screws and clips.
3. Remove the front fender protector side cover clips and remove.
4. Release the front fender protector clips, remove the front fender protector screws and the front fender protector.

INSTALLATION

Installation is in the reverse order of removal.

REAR WHEEL HOUSE PROTECTOR

FENDER PROTECTOR

< REMOVAL AND INSTALLATION >

REAR WHEEL HOUSE PROTECTOR : Exploded View

INFOID:000000011152185

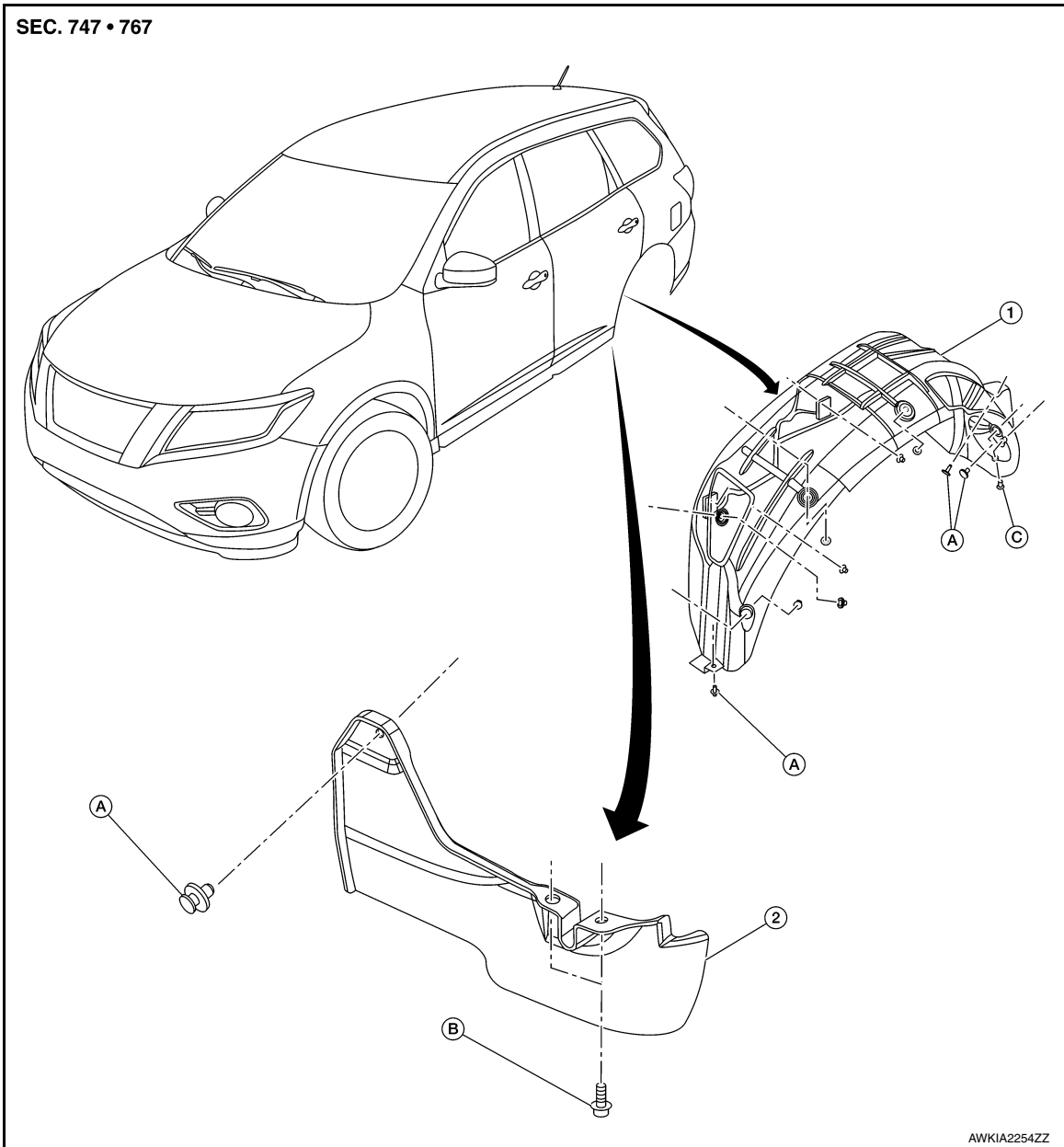

- | | | |
|-------------------------------|-----------------------------|---------|
| 1. Rear wheel house protector | 2. Rear wind deflector | A. Clip |
| B. Rear wind deflector bolt | C. Rear bumper fascia screw | |

REAR WHEEL HOUSE PROTECTOR : Removal and Installation

INFOID:000000011152186

REMOVAL

1. Remove the rear wheel house protector clips.
2. Remove rear wheel house protector plastic nuts and rear bumper fascia screw then remove rear wheel house protector.
3. Remove rear wind deflector bolts and clip and the rear wheel wind deflector.

INSTALLATION

Installation is in the reverse order of removal.

A
B
C
D
E
F
G
H
I
J

EXT

L
M

N

O

P

FRONT UNDER COVER

< REMOVAL AND INSTALLATION >

FRONT UNDER COVER

Exploded View

INFOID:000000011152187

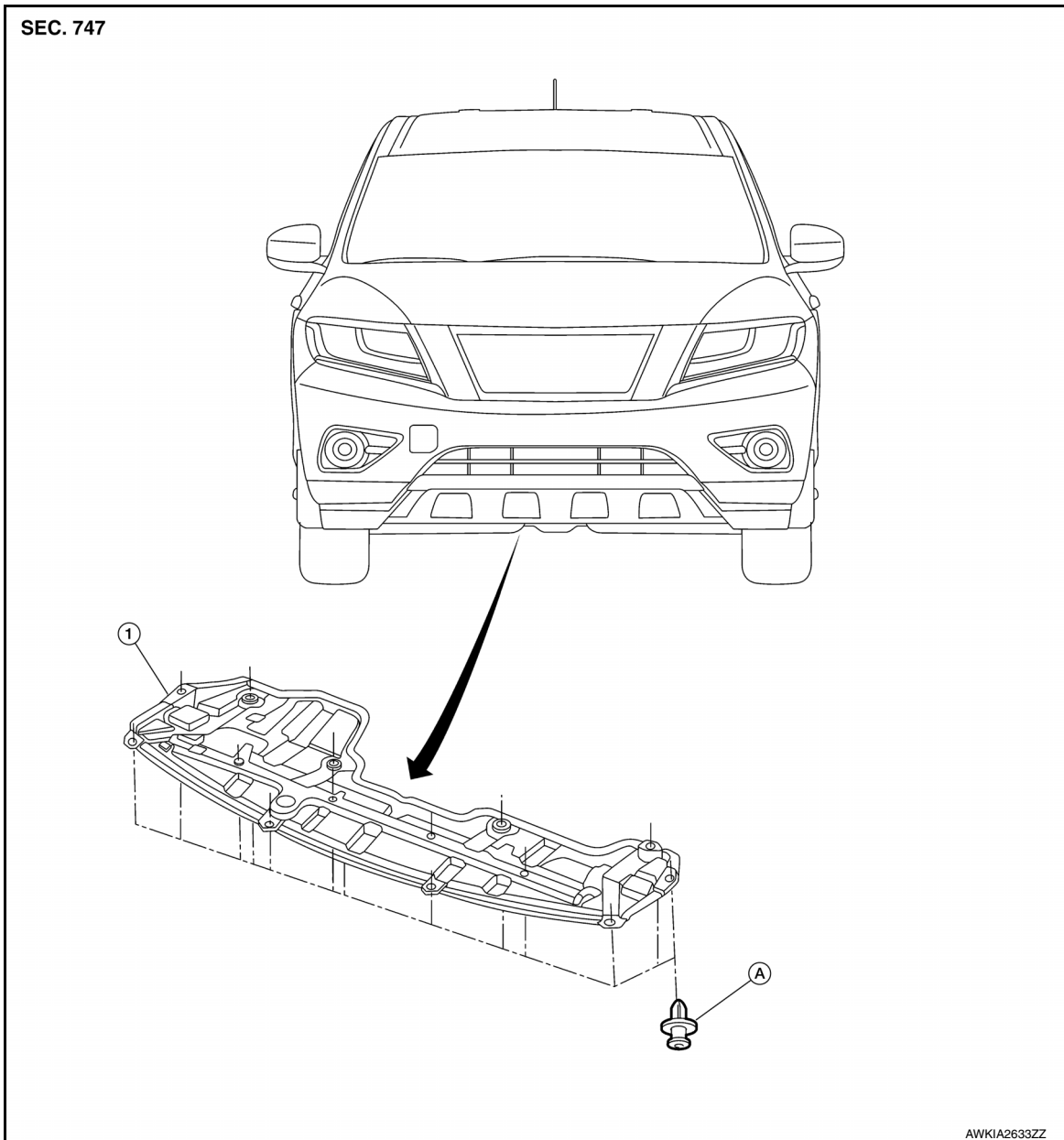

1. Front under cover

A. Clip

Removal and Installation

INFOID:000000011152188

REMOVAL

Release the front under cover clips and remove.

INSTALLATION

Installation is in the reverse order of removal.

ROOF SIDE MOLDING

< REMOVAL AND INSTALLATION >

ROOF SIDE MOLDING

Exploded View

INFOID:000000011152189

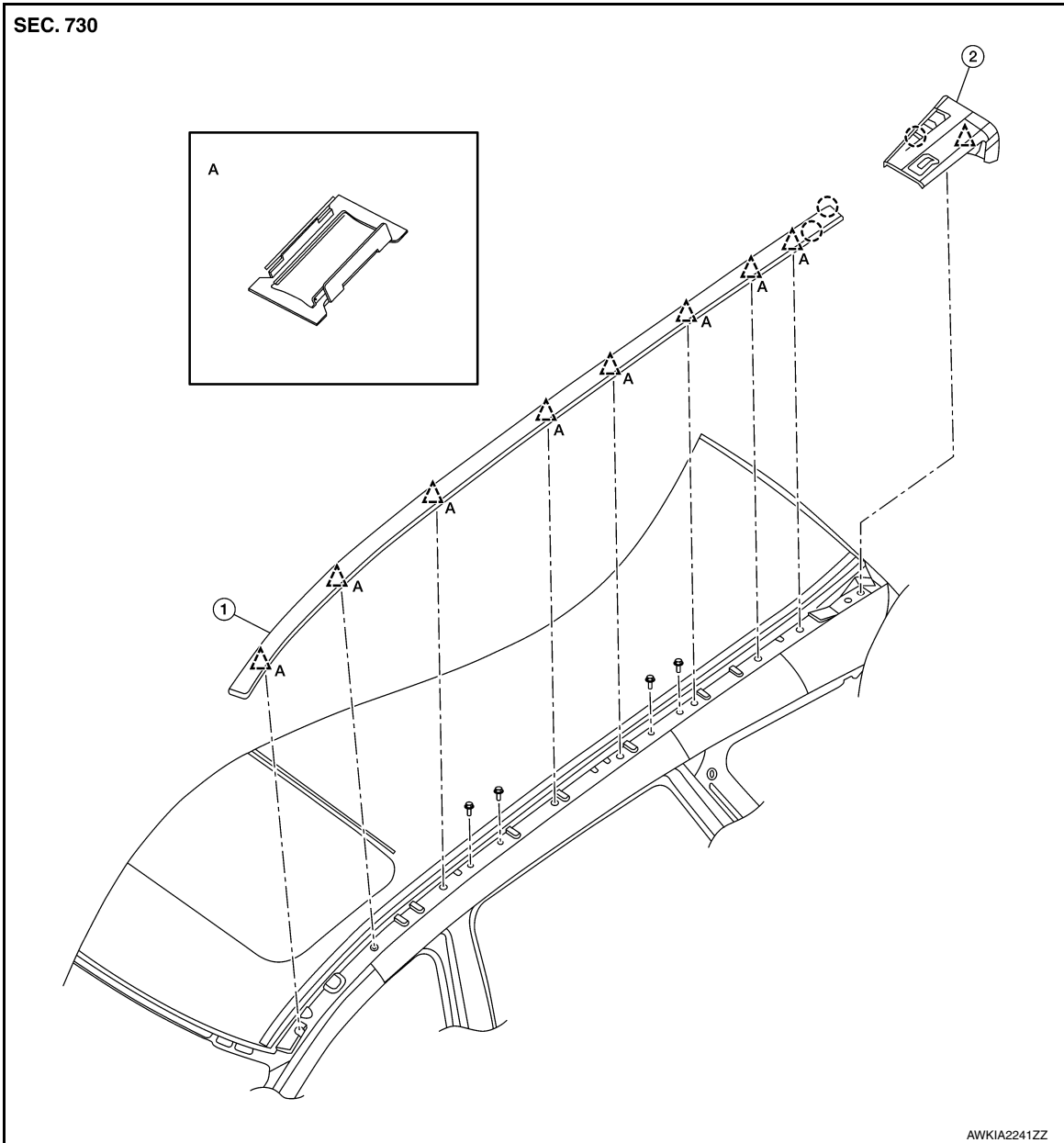

1. Roof side molding

2. Roof side molding end finisher

△ Clip

○● Pawl

Removal and Installation

INFOID:000000011152190

REMOVAL

A
B
C
D
E
F
G
H
I
J
EXT
L
M
N
O
P

ROOF SIDE MOLDING

< REMOVAL AND INSTALLATION >

1. Release the roof side molding clips using a suitable tool (A) and remove the roof side molding.

CAUTION:

Apply protective tape (B) around the roof side molding.

△: Clip

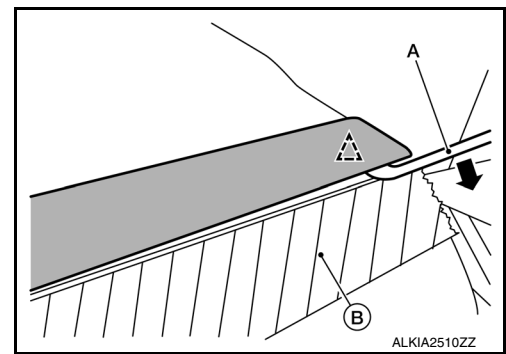

INSPECTION

1. Remove metal clips (A) from roof posts (1) by cutting on each side (←).

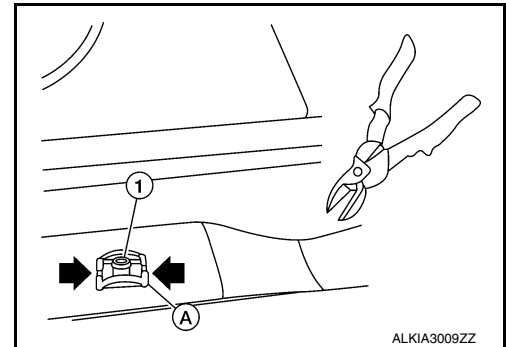

2. Rotate each roof post 90 degrees (A) using a suitable tool.

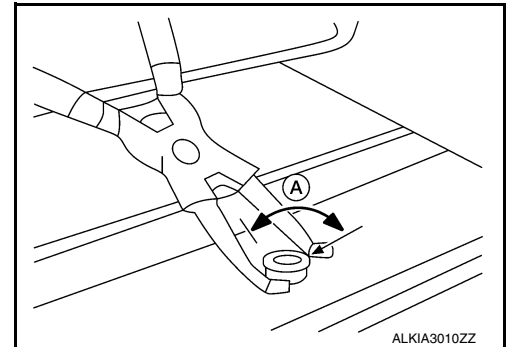

INSTALLATION

Installation is in the reverse order of removal.

CAUTION:

When installing, make sure all clips are on roof side molding. Make sure all old clips have been removed from posts on roof panel.

DOOR OUTSIDE MOLDING

< REMOVAL AND INSTALLATION >

DOOR OUTSIDE MOLDING

Exploded View

INFOID:000000011152191

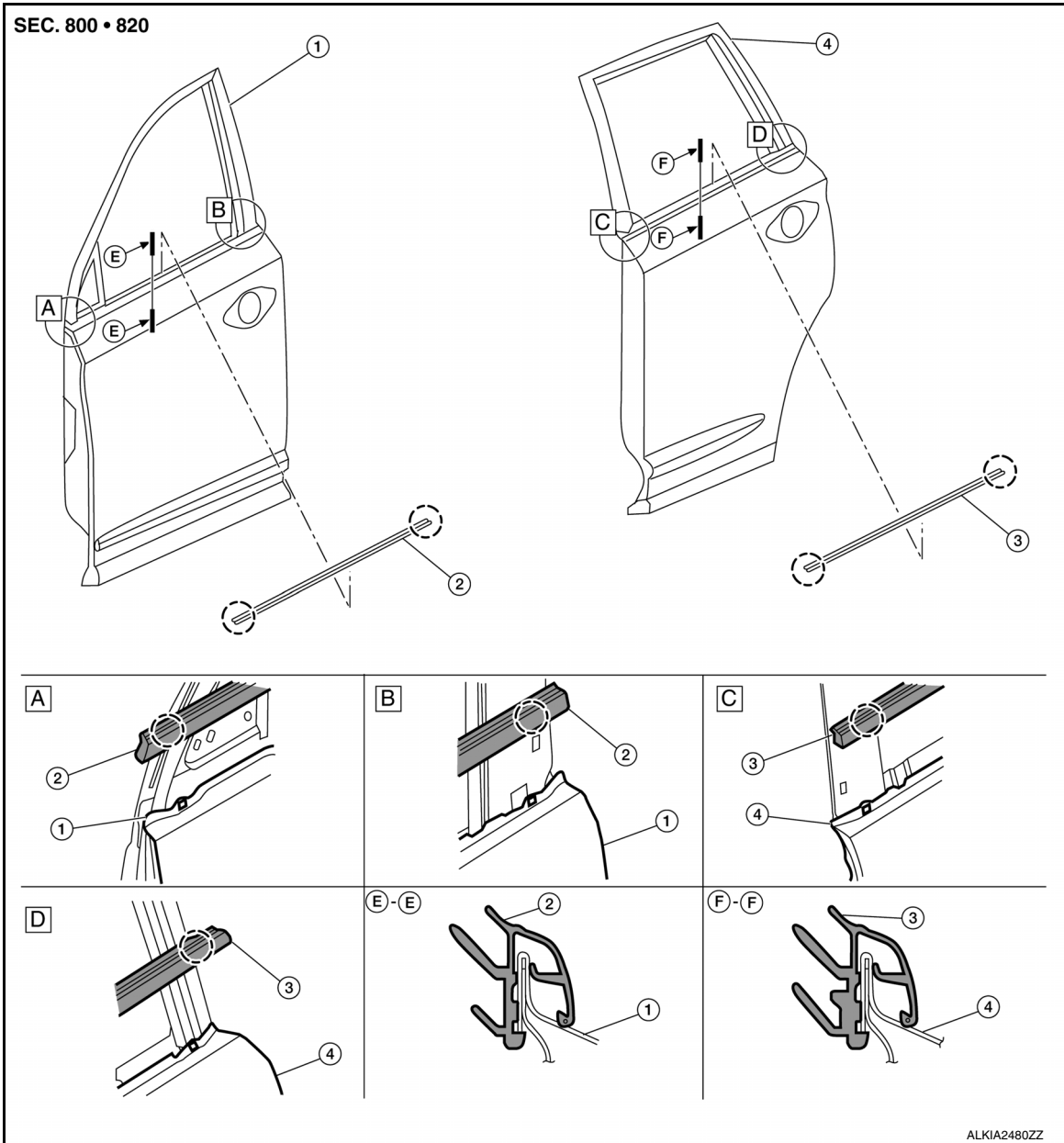

- 1. Front door assembly
- 2. Front door outside molding
- 3. Rear door outside molding
- 4. Rear door assembly
-  Pawl

Removal and Installation

INFOID:000000011152192

FRONT DOOR OUTSIDE MOLDING

Removal

A
B
C
D
E
F
G
H
I
J
EXT
L
M
N
O
P

DOOR OUTSIDE MOLDING

< REMOVAL AND INSTALLATION >

1. Rotate and lift as shown to remove the front door outside molding (1).

CAUTION:

- Apply protective tape on front door panel.
- Do not use excessive force when removing or damage may occur.

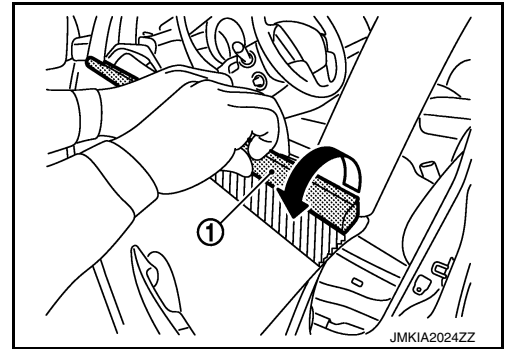

Installation

Installation is in the reverse order of removal.

REAR DOOR OUTSIDE MOLDING

Removal

1. Rotate and lift as shown to remove the rear door outside molding (1).

CAUTION:

- Apply protective tape on rear door panel.
- Do not use excessive force when removing or damage may occur.

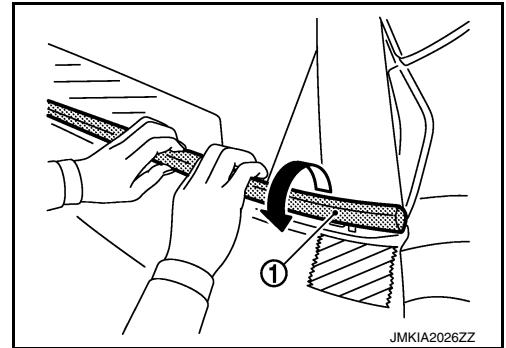

Installation

Installation is in the reverse order of removal.

SIDE GUARD MOLDING

< REMOVAL AND INSTALLATION >

SIDE GUARD MOLDING

Exploded View

INFOID:000000011152193

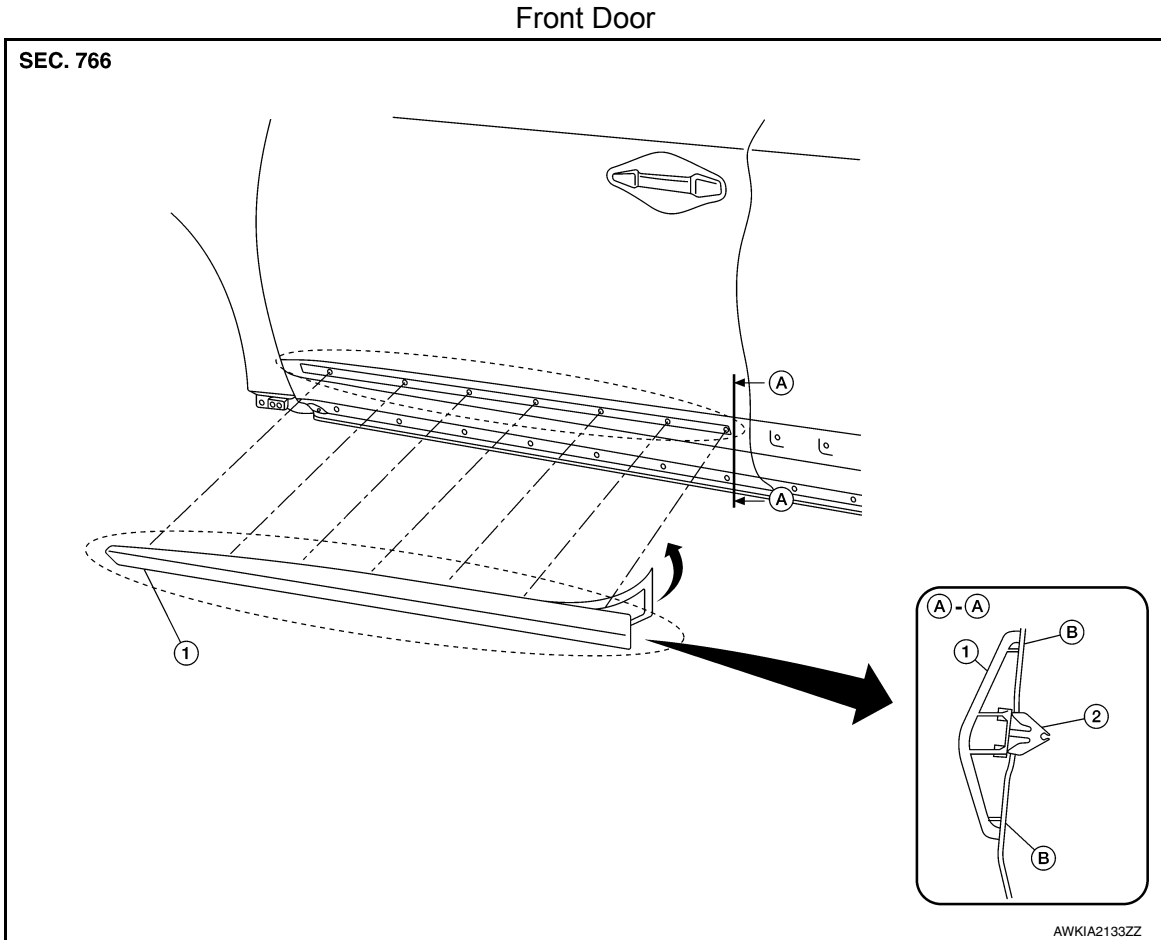

1. Front door side guard molding 2. Clip

B. Double-faced adhesive tape

A
B
C
D
E
F
G
H
I
J

EXT

L
M
N
O
P

SIDE GUARD MOLDING

< REMOVAL AND INSTALLATION >

Rear Door

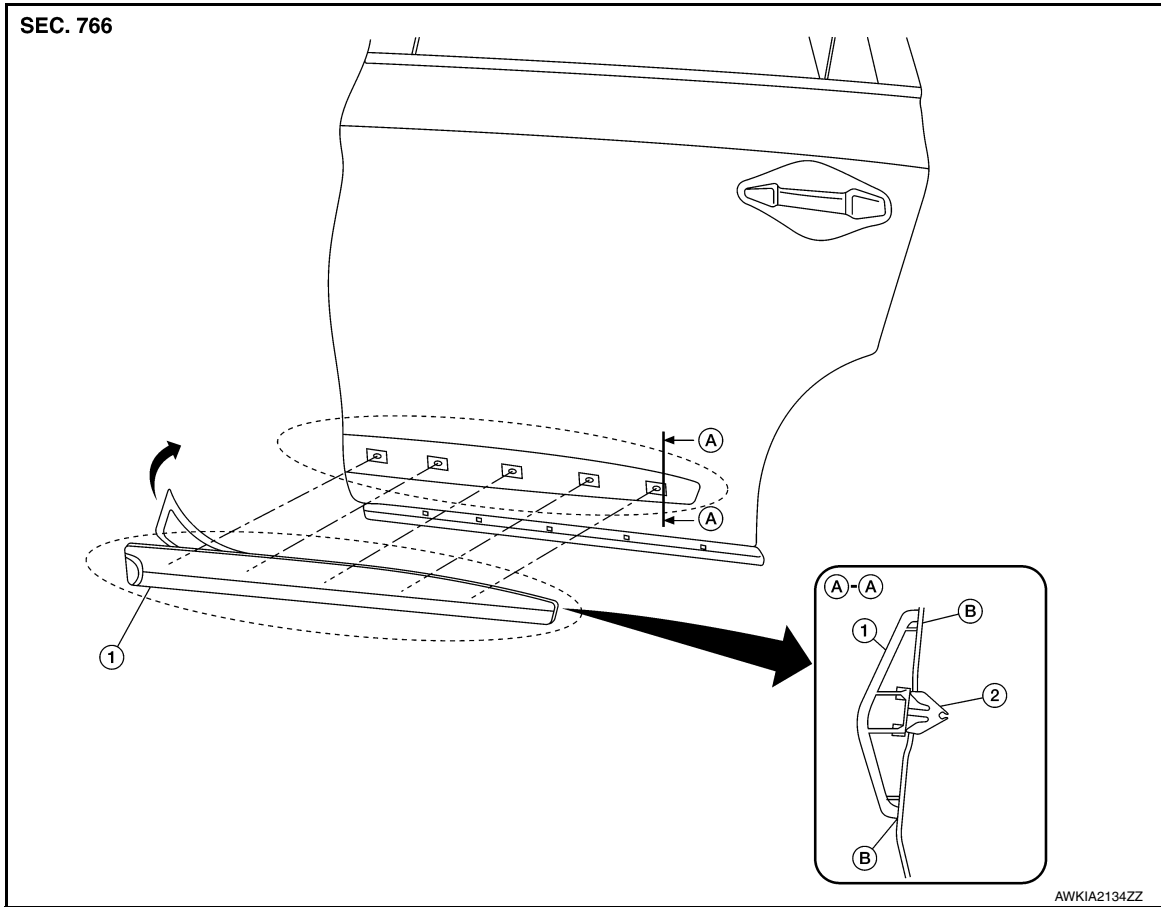

1. Rear door side guard molding

2. Clip

B. Double-faced adhesive tape

Removal and Installation

INFOID:000000011152194

REMOVAL

CAUTION:

Do not apply tack-paper adhesive remover to body panel surface finished with lacquer-based paints.

• Original side guard molding is affixed to body panel with double-faced adhesive tape.

1. Heat molding to between 30° - 40°C (86° - 104°F) with a heat gun.
2. Raise end of molding to release clips, then cut away tape to remove molding. Remove all traces of tape.

INSTALLATION

• On vehicles coated with Hard Clear Coat, use double-faced 3M adhesive tape Product No. 4210 or equivalent, after priming with 3M primer Product No. N200 or C-100 or equivalent.

• The repair parts are also affixed with double-faced adhesive tape.

• To re-use existing molding, clean all traces of double-faced adhesive tape from the molding and apply new double-faced adhesive tape to the molding.

1. Clean the panel surface with isopropyl alcohol or equivalent to degrease the surface.
2. Heat the panel and molding tape surface to 30° - 40°C (86° - 104°F).
3. Apply the side guard molding.
 - Remove the backing sheet from the tape surface.
 - Align the locating pin into the hole in the outer door.
 - Continue aligning the pins into their corresponding holes in the outer door during installation.
4. Press ends by hand and use a roller to apply 5 kg-f (11 ft-lbs) to press molding to door surface.
 - Apply even pressure along molding to insure proper wet out.

CAUTION:

To secure contact, do not wash vehicle for 24 hours after installation.

ROOF RACK

< REMOVAL AND INSTALLATION >

ROOF RACK

Exploded View

INFOID:0000000011152195

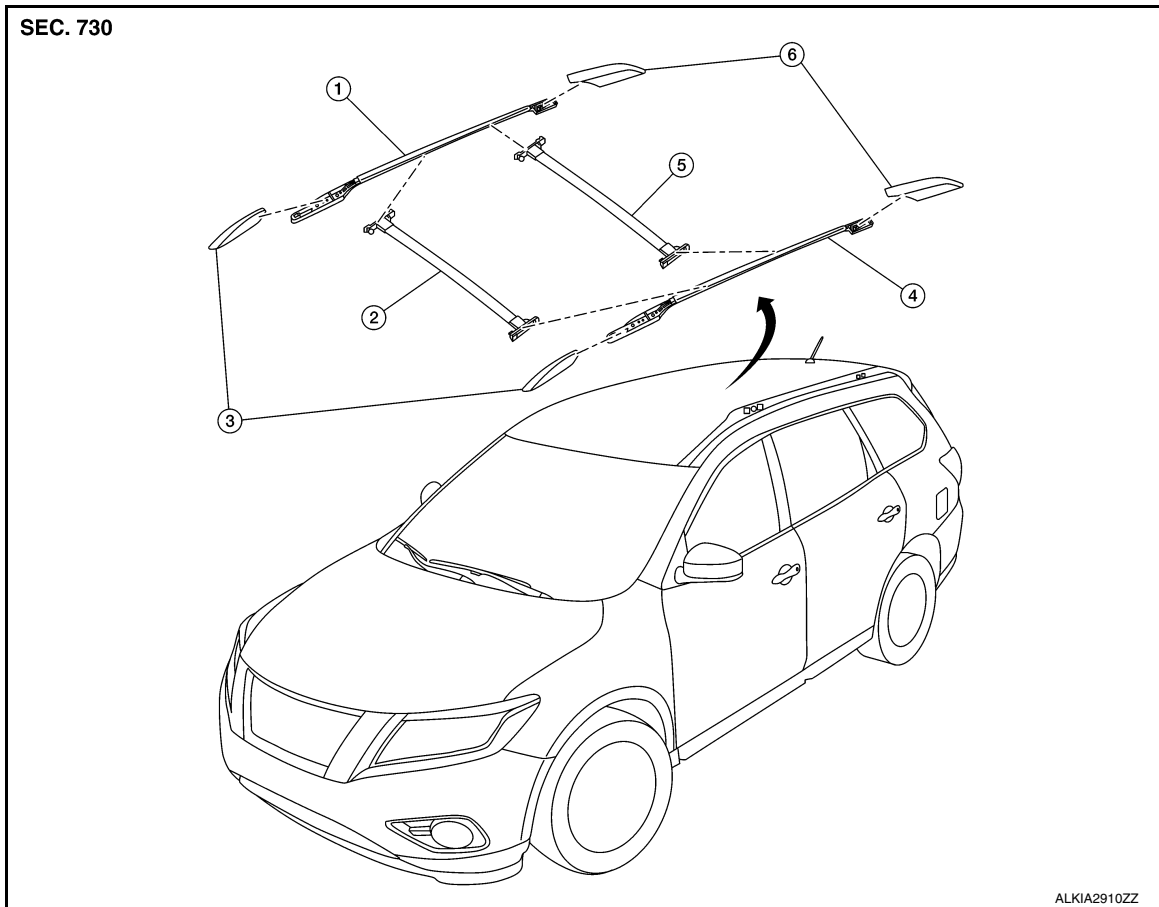

- | | | |
|-----------------------------|---|-----------------|
| 1. Roof rack side rail (RH) | 2. Front sliding crossbar (if equipped) | 3. Front covers |
| 4. Roof rack side rail (LH) | 5. Rear sliding crossbar (if equipped) | 6. Rear covers |

Removal and Installation

INFOID:0000000011152196

REMOVAL

1. Remove the front and rear covers using a suitable tool, then remove the roof rack bolts at the four corners and slide the roof rack back enough to release from roof.
2. Remove the complete roof rack from vehicle.
3. Remove the front and rear sliding crossbar bolts (if equipped) and remove.

INSTALLATION

Installation is in the reverse order of removal.

A
B
C
D
E
F
G
H
I
J
EXT
L
M
N
O
P

DOOR OUTSIDE LOWER MOLDING

< REMOVAL AND INSTALLATION >

DOOR OUTSIDE LOWER MOLDING

Exploded View

INFOID:000000011152197

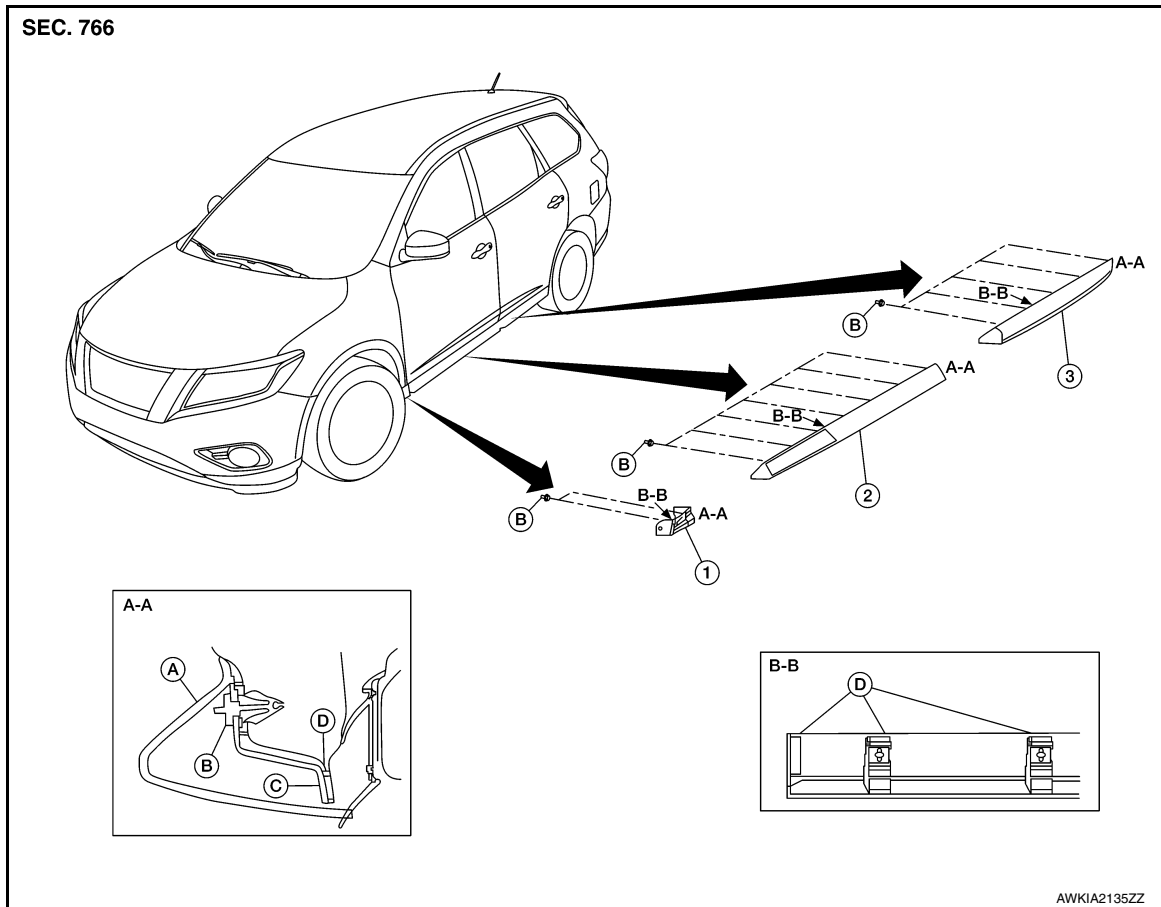

- | | | |
|---------------------------------------|-------------------------------------|------------------------------------|
| 1. Front fender outside lower molding | 2. Front door outside lower molding | 3. Rear door outside lower molding |
| A. Outside lower molding | B. Clip | C. Outer sheet metal |
| D. Adhesive | | |

Removal and Installation

INFOID:000000011152198

FRONT FENDER OUTSIDE LOWER MOLDING

Removal

1. Remove the front fender protector screw.
2. Release the clips from the front fender outside lower molding (1), using a suitable tool (A).

CAUTION:

- Apply protective tape (B) to the front fender to protect the painted surface from damage.
- Release the clips slowly and carefully.
- Do not pull the front fender outside lower molding.

 Clip

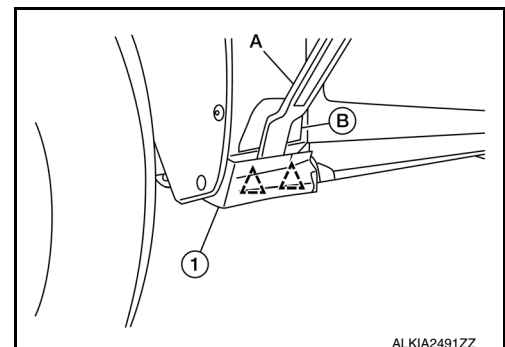

3. Remove the front fender outside lower molding.

Installation

DOOR OUTSIDE LOWER MOLDING

< REMOVAL AND INSTALLATION >

Installation is in the reverse order of removal.

CAUTION:

- When installing, visually check the outside lower molding and the clips and replace with new parts if they have been damaged.
- When installing outside lower molding, make sure that the clips are attached to the molding. Make sure old clips have all been removed from fender.

FRONT DOOR OUTSIDE LOWER MOLDING

Removal

1. Release the clips from the front door outside lower molding (1) by starting at the rear and moving forward, using a suitable tool (A).

CAUTION:

- Apply protective tape (B) to the door to protect the painted surface from damage.
- Release the clips slowly and carefully.
- Do not pull the front door outside lower molding.

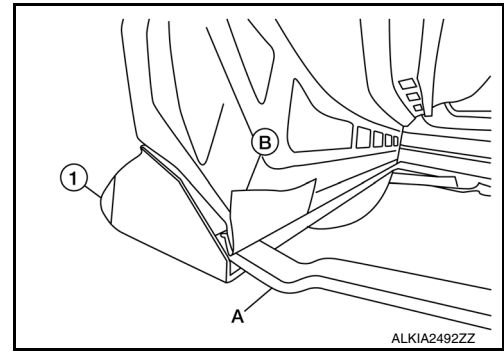

2. Remove the front door outside lower molding.

Installation

Installation is in the reverse order of removal.

CAUTION:

- When installing, visually check the outside lower molding and the clips and replace with new parts if they have been damaged.
- When installing outside lower molding, make sure that the clips are attached to the molding. Make sure old clips have all been removed from door.

REAR DOOR OUTSIDE LOWER MOLDING

Removal

1. Release the clips from the rear door outside lower molding (1) by starting at the rear and moving forward, using a suitable tool (A).

CAUTION:

- Apply protective tape (B) to the door to protect the painted surface from damage.
- Release the clips slowly and carefully.
- Do not pull the rear door outside lower molding.

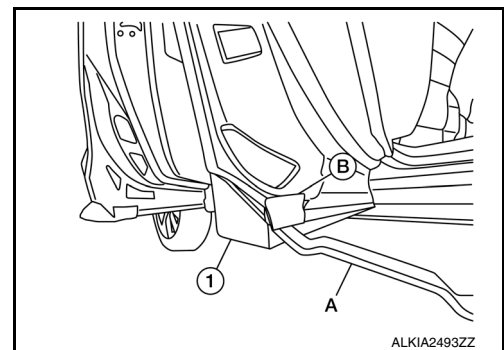

2. Remove the rear door outside lower molding.

Installation

Installation is in the reverse order of removal.

CAUTION:

- When installing, visually check the outside lower molding and the clips and replace with new parts if they have been damaged.
- When installing outside lower molding, make sure that the clips are attached to the molding. Make sure old clips have all been removed from door.

A
B
C
D
E
F
G
H
I
J
L
M
N
O
P

EXT

SILL MOLDING

< REMOVAL AND INSTALLATION >

SILL MOLDING

Exploded View

INFOID:000000011152199

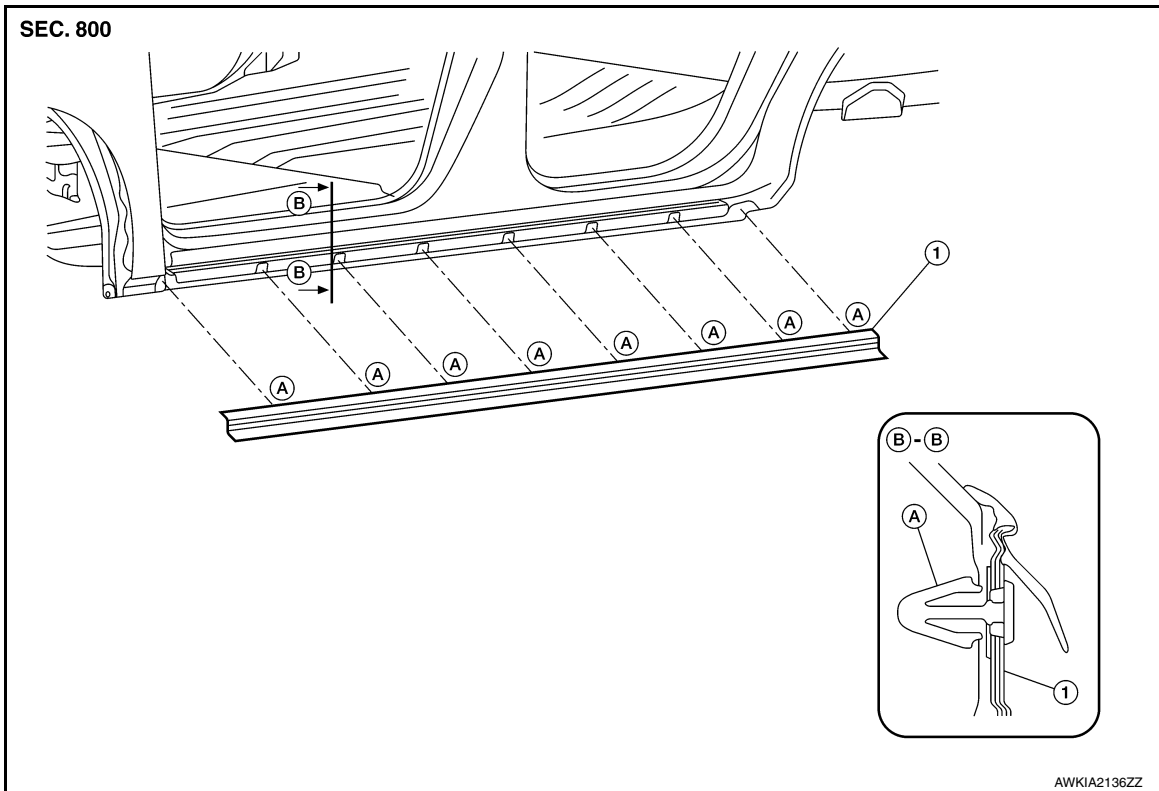

1. Sill molding

A. Clip

Removal and Installation

INFOID:000000011152200

REMOVAL

1. Release sill molding clips with a suitable tool (A), then remove the sill molding (1).

CAUTION:

Disengage the clips slowly and carefully.

△: Clip

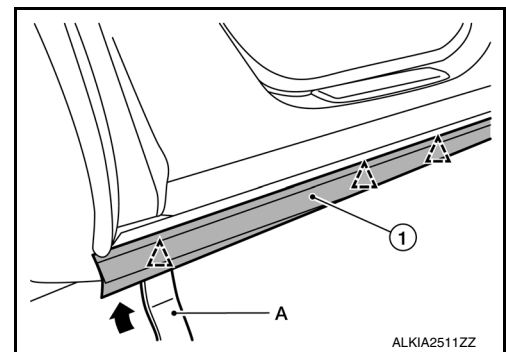

INSTALLATION

Installation is in the reverse order of removal.

CAUTION:

- When installing, visually check the sill molding and the clips and replace them with new parts if they have been damaged.
- When installing the sill molding, check that clips are securely placed in panel holes on body, then press them in.

REAR SPOILER

< REMOVAL AND INSTALLATION >

REAR SPOILER

Exploded View

INFOID:000000011152201

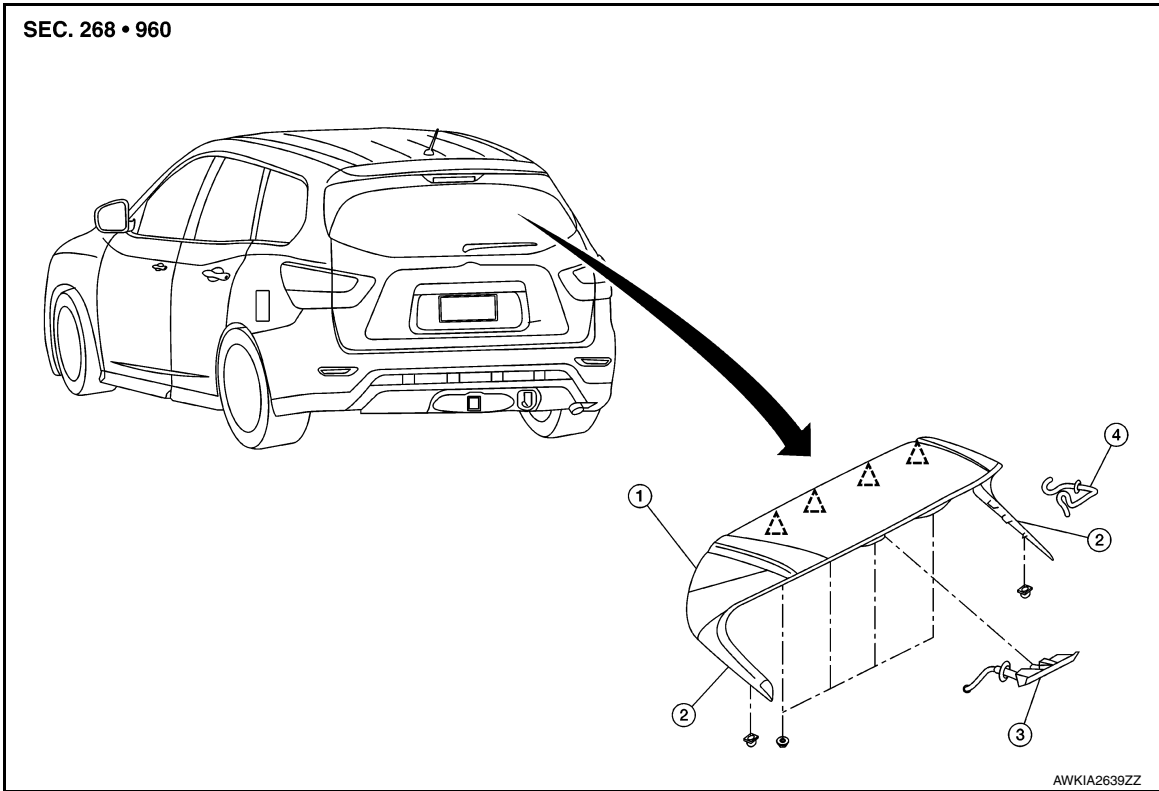

- | | | |
|-----------------------|---|---------------------------|
| 1. Rear spoiler | 2. Rear spoiler side trim cover (LH/RH) | 3. High-mounted stop lamp |
| 4. Rear washer nozzle | Clip | |

Removal and Installation

INFOID:000000011152202

EXT

REMOVAL

1. Remove the back door side finishers (LH/RH). Refer to [EXT-43, "Removal and Installation"](#).
2. Remove the rear spoiler nuts.
3. Disconnect the harness connector from high-mounted stop lamp.
4. Release the rear washer nozzle tube.
5. Release the rear spoiler clips with a suitable tool (A), and then remove the rear spoiler.

CAUTION:

Apply protective tape (B) to the roof panel and rear spoiler to protect the painted surface from damage.

Clip

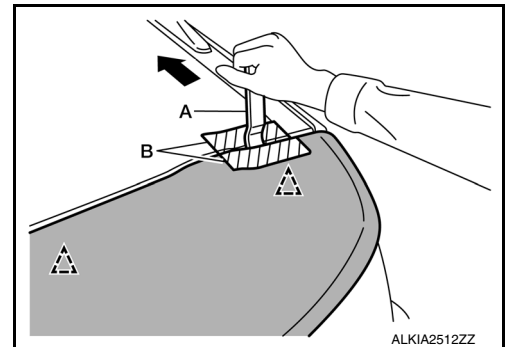

6. Remove following parts (if necessary) after removing rear spoiler.
 - High-mounted stop lamp
 - Rear spoiler side trim covers (LH/RH)
 - Rear washer nozzle

REAR SPOILER

< REMOVAL AND INSTALLATION >

INSTALLATION

Installation is in the reverse order of removal.

CAUTION:

- When installing, visually check the rear spoiler and the clips and replace them with new parts if they are damaged.
- When installing, make sure that the clips and bolts are securely placed in back door panel holes, and then press them in.
- Do not wash the vehicle within 24 hours after installing to allow adhesive time to cure.

BACK DOOR OUTER FINISHER

< REMOVAL AND INSTALLATION >

BACK DOOR OUTER FINISHER

Exploded View

INFOID:000000011152203

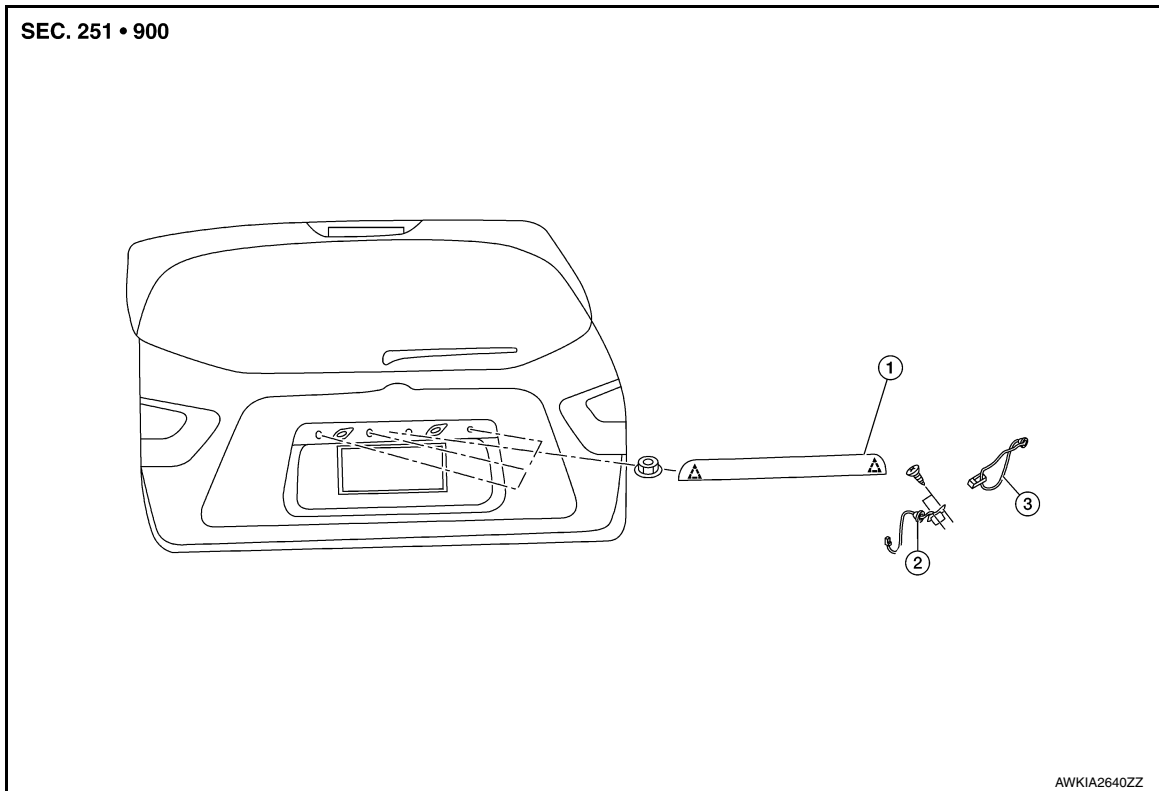

1. Back door outer finisher

2. Rear camera

3. Back door opener request switch

 Clip

Removal and Installation

INFOID:000000011152204

EXT

REMOVAL

1. Remove the back door lower finisher. Refer to [INT-35, "BACK DOOR LOWER FINISHER : Removal and Installation"](#).
2. Disconnect the harness connectors from rear view camera and back door opener switch.
3. Remove the back door outer finisher nuts.
4. Release the clips, then remove the back door outer finisher.
5. Remove the following parts (if necessary) after removing back door outer finisher.
 - Rear view camera
 - Back door opener switch
 - License plate lamp

INSTALLATION

Installation is in the reverse order of removal.