

SECTION **SB**
SEAT BELT

A
B
C
D
E
F
G
SB
I
J
K
L
M
N
O
P

CONTENTS

PRECAUTION	2	REMOVAL AND INSTALLATION	8
PRECAUTIONS	2	FRONT SEAT BELT	8
Precaution for Supplemental Restraint System (SRS) "AIR BAG" and "SEAT BELT PRE-TENSIONER"	2	Front Seat Belt	8
Precaution for Seat Belt Service	2	SECOND ROW SEAT BELT	13
Precaution for Work	2	Second Row Seat Belt	13
PREPARATION	4	THIRD ROW SEAT BELT	17
PREPARATION	4	Third Row Seat Belt	17
Special Service Tool	4	LATCH (LOWER ANCHORS AND TETHER FOR CHILDREN) SYSTEM	19
BASIC INSPECTION	5	Removal and Installation	19
COMPONENT INSPECTION	5	TOP TETHER STRAP CHILD RESTRAINT	20
Inspection	5	Removal and Installation	20

PRECAUTIONS

< PRECAUTION >

PRECAUTION

PRECAUTIONS

Precaution for Supplemental Restraint System (SRS) "AIR BAG" and "SEAT BELT PRE-TENSIONER"

INFOID:000000011149839

The Supplemental Restraint System such as "AIR BAG" and "SEAT BELT PRE-TENSIONER", used along with a front seat belt, helps to reduce the risk or severity of injury to the driver and front passenger for certain types of collision. Information necessary to service the system safely is included in the SR and SB section of this Service Manual.

WARNING:

- To avoid rendering the SRS inoperative, which could increase the risk of personal injury or death in the event of a collision which would result in air bag inflation, all maintenance must be performed by an authorized NISSAN/INFINITI dealer.
- Improper maintenance, including incorrect removal and installation of the SRS, can lead to personal injury caused by unintentional activation of the system. For removal of Spiral Cable and Air Bag Module, see the SR section.
- Do not use electrical test equipment on any circuit related to the SRS unless instructed to in this Service Manual. SRS wiring harnesses can be identified by yellow and/or orange harnesses or harness connectors.

PRECAUTIONS WHEN USING POWER TOOLS (AIR OR ELECTRIC) AND HAMMERS

WARNING:

- When working near the Airbag Diagnosis Sensor Unit or other Airbag System sensors with the Ignition ON or engine running, DO NOT use air or electric power tools or strike near the sensor(s) with a hammer. Heavy vibration could activate the sensor(s) and deploy the air bag(s), possibly causing serious injury.
- When using air or electric power tools or hammers, always switch the Ignition OFF, disconnect the battery and wait at least three minutes before performing any service.

Precaution for Seat Belt Service

INFOID:000000011149840

CAUTION:

- Before removing the seat belt pre-tensioner assembly, turn the ignition switch OFF, disconnect both battery terminals and wait at least three minutes. For approximately three minutes after the battery terminals have been removed, it is still possible for the air bag and seat belt pre-tensioner to deploy. Therefore, do not attempt work on any SRS connectors or wires until at least three minutes have passed.
- After replacing or reinstalling seat belt pre-tensioner assembly or reconnecting seat belt pre-tensioner assembly connector, make sure entire SRS operates properly. Refer to [SRC-14, "SRS Operation Check"](#).
- Do not disassemble buckle or seat belt assembly.
- Replace anchor bolts if they are deformed or worn out.
- Do not oil tongue or buckle.
- If any component of seat belt assembly is questionable, do not repair. Replace the whole seat belt assembly.
- If webbing is cut, frayed or damaged, replace seat belt assembly.
- When replacing seat belt assembly, use a genuine NISSAN seat belt assembly.

Precaution for Work

INFOID:000000011149841

- When removing or disassembling each component, be careful not to damage or deform it. If a component may be subject to interference, be sure to protect it with a shop cloth.
- When removing (disengaging) components with a screwdriver or similar tool, be sure to wrap the component with a shop cloth or vinyl tape to protect it.
- Protect the removed parts with a shop cloth and prevent them from being dropped.
- Replace a deformed or damaged clip.
- If a part is specified as a non-reusable part, always replace it with a new one.
- Be sure to tighten bolts and nuts securely to the specified torque.
- After installation is complete, be sure to check that each part works properly.

PRECAUTIONS

< PRECAUTION >

- Follow the steps below to clean components:
- Water soluble dirt:
 - Dip a soft cloth into lukewarm water, wring the water out of the cloth and wipe the dirty area.
 - Then rub with a soft, dry cloth.
- Oily dirt:
 - Dip a soft cloth into lukewarm water with mild detergent (concentration: within 2 to 3%) and wipe the dirty area.
 - Then dip a cloth into fresh water, wring the water out of the cloth and wipe the detergent off.
 - Then rub with a soft, dry cloth.
- Do not use organic solvent such as thinner, benzene, alcohol or gasoline.
- For genuine leather seats, use a genuine leather seat cleaner.

A

B

C

D

E

F

G

SB

I

J

K

L

M

N

O

P

PREPARATION

< PREPARATION >

PREPARATION

PREPARATION

Special Service Tool

INFOID:000000011149842

The actual shape of the tools may differ from those illustrated here.

Tool number (TechMate No.) Tool name	Description
— (J-46534) Trim Tool Set	Removing trim components

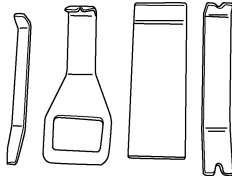

AWJIA0483ZZ

COMPONENT INSPECTION

< BASIC INSPECTION >

BASIC INSPECTION

COMPONENT INSPECTION

Inspection

INFOID:0000000011149843

AFTER A COLLISION

WARNING:

Inspect all seat belt assemblies including retractors and attaching hardware after any collision. NISSAN/INFINITI recommends that all seat belt assemblies in use during a collision be replaced unless the collision was minor and the belts show no damage and continue to operate properly. Failure to do so could result in serious personal injury in an accident. Seat belt assemblies not in use during a collision should also be replaced if either damage or improper operation is noted. Seat belt pretensioners should be replaced even if the seat belts are not in use during a frontal collision in which the air bags are deployed.

Replace any seat belt assembly (including anchor bolts) if:

- The seat belt was in use at the time of a collision (except for minor collisions and the belts, retractors and buckles show no damage and continue to operate properly).
- The seat belt was damaged in an accident (i.e. torn webbing, bent retractor or guide, etc.).
- The seat belt attaching point is damaged in an accident. Inspect the seat belt attaching area for damage or distortion and repair if necessary before installing a new seat belt assembly.
- Anchor bolts are deformed or worn out.
- The seat belt pre-tensioner should be replaced even if the seat belts are not in use during the collision in which the air bags are deployed.

PRELIMINARY CHECKS

1. Check the seat belt warning lamp for proper operation per the following:
 - a. Turn ignition switch ON. The seat belt warning lamp should illuminate.
 - b. Fasten driver seat belt. The seat belt warning lamp should turn OFF.
 2. If the air bag warning lamp is blinking, perform self-diagnosis with CONSULT and air bag warning lamp. Refer to [SRC-14. "Diagnosis Description"](#).
 3. Check that the seat belt retractor, seat belt anchor and buckle bolts are tightened firmly.
 4. Check the shoulder seat belt guide and shoulder belt height adjuster for front seats. Check that guide swivels freely and that webbing lays flat and does not bind in guide. Check that height adjuster operates properly and holds securely.
 5. Check retractor operation:
 - a. Fully extend the seat belt webbing and check for twists, tears or other damage.
 - b. Allow the seat belt to retract. Check that webbing returns smoothly and completely into the retractor. If the seat belt does not return smoothly, wipe the inside of the loops with a clean paper cloth. Dirt build-up in the loops of the upper anchors can cause the seat belts to retract slowly.
 - c. Fasten the seat belt. Check that seat belt returns smoothly and completely to the retractor. If the webbing does not return smoothly, the cause may be an accumulation of dust or dirt. Use the "SEAT BELT TAPE SET" and perform the following steps.
 - d. Inspect the front seat belt D-ring anchor
 1. Pull the seat belt out to a length of 500 mm (19.69 in) or more.
 2. Hold the seat belt at the center pillar webbing opening with a clip or other device.
 3. Pass a thin wire through the D-ring anchor webbing opening. Hold both ends of the wire and pull it tightly while moving it up and down several times along the webbing opening surface to remove dirt stuck there.
 4. Any dirt that cannot be removed with the wire can be removed by cleaning the opening with a clean cloth.
 5. Apply tape at the point where the webbing contacts the D-ring anchor webbing opening.

NOTE:
Apply the tape so that there is no slack or wrinkling.
 6. Remove the clip holding the seat belt and check that the webbing returns smoothly.
6. Repeat steps above if necessary to check the other seat belts.

COMPONENT INSPECTION

< BASIC INSPECTION >

SEAT BELT RETRACTOR ON-VEHICLE CHECK

Emergency Locking Retractors (ELR) and Automatic Locking Retractors (ALR)

NOTE:

All seat belt retractors are Emergency Locking Retractors (ELR) type. In an emergency (sudden stop) the retractor will lock and prevent the webbing from extending any further. All 3-point type seat belt retractors except the driver seat belt also have an Automatic Locking Retractors (ALR) mode. The ALR mode (also called child restraint mode) is used when installing child seats. The ALR mode is activated when the seat belt is fully extended. When the webbing is then retracted partially, the ALR mode automatically locks the seat belt in a specific position so the webbing cannot be extended any further. To cancel the ALR mode, allow the seat belt to fully wind back into the retractor.

Check the seat belt retractors with the following test(s) to determine if a retractor assembly is operating properly.

ELR Function Stationary Check

Grasp the shoulder webbing and pull forward quickly. The retractor should lock and prevent the belt from extending further.

ALR Function Stationary Check

1. Pull out the entire length of seat belt from retractor until a click is heard.
2. Retract the webbing partially. A clicking noise should be heard as the webbing retracts, indicating that the retractor is in the Automatic Locking Retractors (ALR) mode.
3. Grasp the seat belt and try to pull out the retractor. The webbing must lock and not extend any further. If it does not operate normally, replace the retractor assembly.
4. Allow the entire length of the webbing to retract to cancel the automatic locking mode.

ELR Function Moving Check

WARNING:

Perform the following test in a safe, open area clear of other vehicles and obstructions (for example, a large, empty parking lot). Road surface must be paved and dry. Never perform the following test on wet or gravel roads or on public streets and highways. This could result in an accident and serious personal injury. The driver and passenger must be prepared to brace themselves in the event that the retractor does not lock.

1. Fasten driver seat belt. Buckle a passenger into the seat for the belt that is to be tested.
2. Proceed to the designated safe area.
3. Drive the vehicle at approximately 16 km/h (10 mph). Notify any passengers of a pending sudden stop and the driver and passenger must be prepared to brace themselves in the event that the retractor does not lock. Apply brakes firmly and make a very hard stop.

During stopping, seat belts should lock and not be extended. If the seat belt retractor assembly does not lock, perform the retractor off-vehicle check.

FRONT SEAT BELT RETRACTOR OFF-VEHICLE CHECK

1. Remove the front seat belt retractor. Refer to [SB-8, "Front Seat Belt"](#).
2. Slowly pull out webbing while tilting the seat belt retractor forward from the mounted position without twisting the seat belt retractor as shown.

A : The webbing can be pulled out if the retractor is tilted 15° degree or less.

B : The webbing can not be pulled out if the retractor is tilted 27° degrees or more.

NOTE:

A and B show tilting angles.

↔: Front

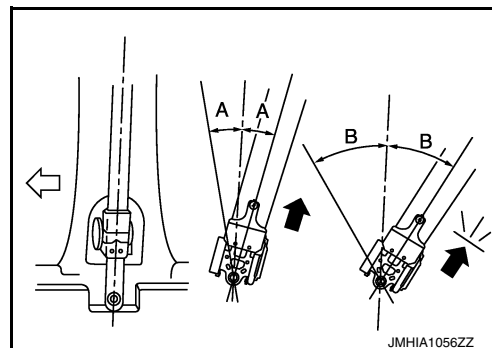

3. Replace the seat belt retractor if it does not operate within specifications.

SECOND AND THIRD SEAT BELT (LH/RH) RETRACTOR OFF-VEHICLE CHECK

COMPONENT INSPECTION

< BASIC INSPECTION >

1. Remove the seat belt retractor. Refer to [SB-13, "Second Row Seat Belt"](#) (second row seat) or [SB-17, "Third Row Seat Belt"](#) (third row seat).
2. Slowly pull out webbing while tilting the seat belt retractor forward from the mounted position without twisting the seat belt retractor as shown.

A : The webbing can be pulled out if the retractor is tilted 15° degree or less.

B : The webbing can not be pulled out if the retractor is tilted 27° degrees or more.

NOTE:

A and B show tilting angles.

⇐: Front

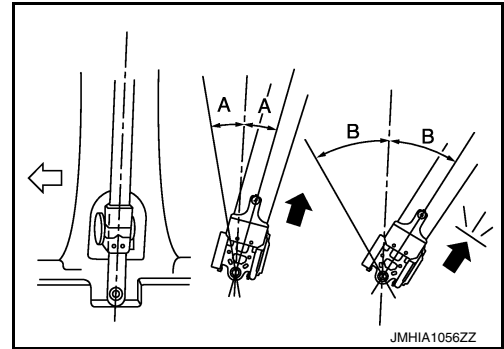

3. Replace the seat belt retractor if it does not operate within specifications.

SECOND SEAT BELT RETRACTOR (center) OFF-VEHICLE CHECK

1. Remove the seat belt retractor. Refer to [SB-13, "Second Row Seat Belt"](#).
2. Slowly pull out webbing while tilting the seat belt retractor forward from the mounted position without twisting the seat belt retractor as shown.

A : The webbing can be pulled out if the retractor is tilted 15° degree or less.

B : The webbing can not be pulled out if the retractor is tilted 27° degrees or more.

NOTE:

A and B show tilting angles.

⇐: Front

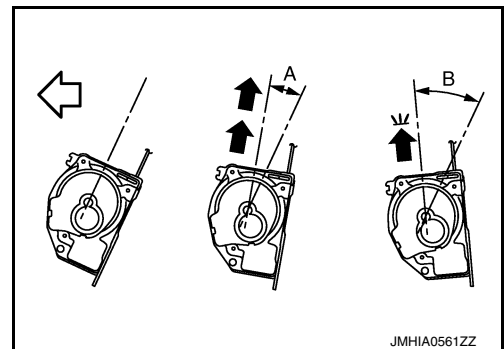

3. Replace the seat belt retractor if it does not operate within specifications.

A
B
C
D
E
F
G
SB
I
J
K
L
M
N
O
P

FRONT SEAT BELT

< REMOVAL AND INSTALLATION >

REMOVAL AND INSTALLATION

FRONT SEAT BELT

Front Seat Belt

INFOID:000000011149844

EXPLODED VIEW

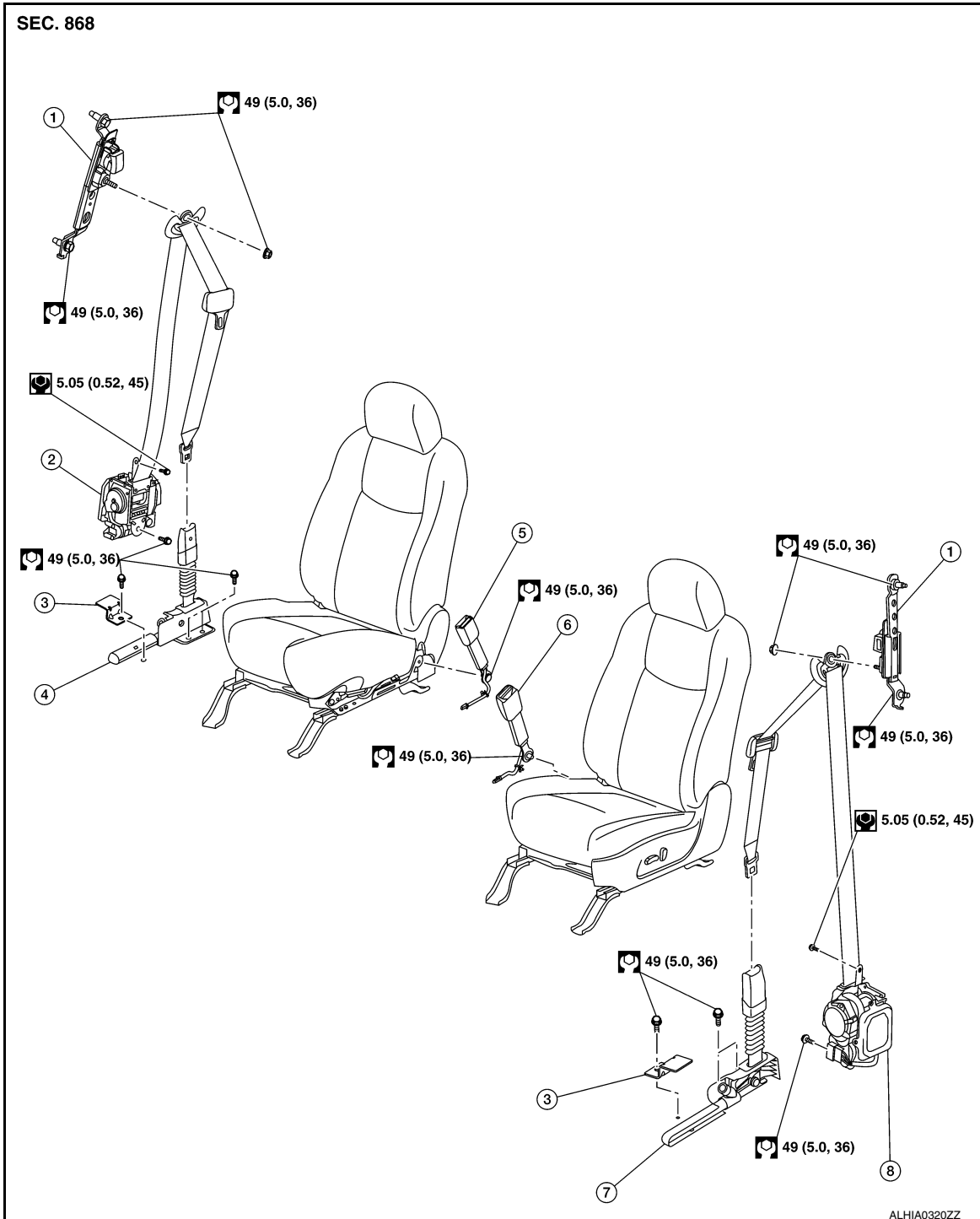

- | | | |
|--------------------------------------|-----------------------------|--------------------------|
| 1. Seat belt height adjuster (LH/RH) | 2. Seat belt retractor (RH) | 3. Floor bracket (LH/RH) |
| 4. Lap belt pretensioner (RH) | 5. Seat belt buckle (RH) | 6. Seat belt buckle (LH) |
| 7. Lap belt pretensioner (LH) | 8. Seat belt retractor (LH) | |

FRONT SEAT BELT

< REMOVAL AND INSTALLATION >

SEAT BELT RETRACTOR

Removal

WARNING:

- Before servicing the SRS, turn the ignition switch off, disconnect both battery terminals then wait at least three minutes.
- Do not drop the seat belt retractor. Always handle it with care.
- Always point pretensioner cylinder away from body when handling.

1. Disconnect negative and positive battery terminals, then wait at least three minutes. Refer to [PG-95, "Removal and Installation"](#).
2. Slide front seat to the full forward position.
3. Release seat belt retractor (1) from the lap belt pretensioner.
 - a. Insert suitable tool (A) into slots (B).
 - b. On opposite side insert suitable tool (C) into hole (D).
 - c. Depress suitable tools (A) and (C) at the same time and remove seat belt retractor (1) as shown.

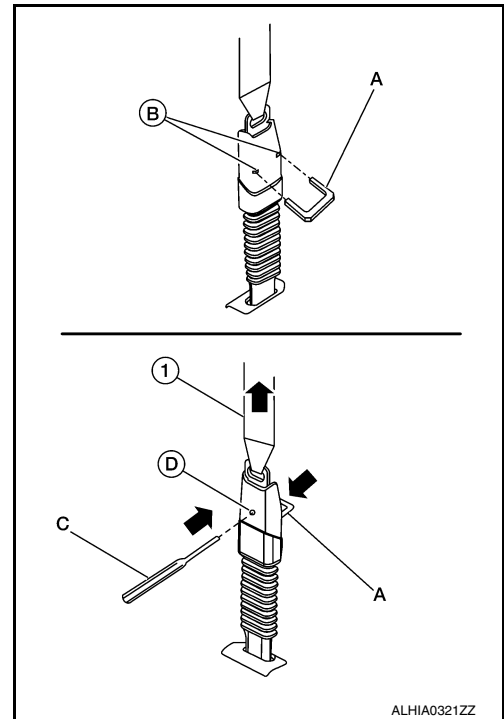

4. Remove the center pillar upper finisher. Refer to [INT-20, "CENTER PILLAR UPPER FINISHER : Removal and Installation"](#).
5. Remove the D-ring anchor nut.
CAUTION:
Before removing the D-ring anchor nut, note the positions of washers and spacers for correct installation.

6. Disconnect the harness connector from the seat belt retractor.
CAUTION:
 - For removing/installing the shoulder belt pre-tensioner harness connector, insert a thin screwdriver wrapped in tape into the notch, then lift the lock and remove the harness connector as shown.
 - Install the harness connector with the lock raised, and push the lock into the harness connector as shown.
 - After installing the harness connector, check that the lock is pushed in securely.

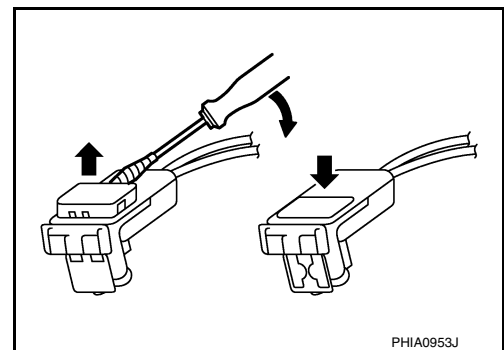

7. Remove the seat belt retractor bolts, then remove the seat belt retractor.

Installation

Installation is in the reverse order of removal.

FRONT SEAT BELT

< REMOVAL AND INSTALLATION >

- Tighten the D-ring anchor nut and seat belt retractor bolts to specification.
- Make sure that the seat belt height adjuster is locked in the lowest position and is aligned with the finisher opening during installation.
- Make sure both the D-ring anchor and seat belt height adjuster operate freely.
- Always perform an inspection after repair to make sure the system is functioning within specifications. Refer to [SB-5, "Inspection"](#).

LAP BELT PRETENSIONER

Removal

WARNING:

- **Before servicing the SRS, turn the ignition switch off, disconnect both battery terminals then wait at least three minutes.**
 - **Do not drop the lap belt pretensioner. Always handle it with care.**
 - **Always point pretensioner cylinder away from body when handling.**
1. Disconnect negative and positive battery terminals, then wait at least three minutes. Refer to [PG-95, "Removal and Installation"](#).
 2. Remove front seat. Refer to [SE-87, "Removal and Installation"](#).
 3. Release seat belt retractor (1) from the lap belt pretensioner.
 - a. Insert suitable tool (A) into slots (B).
 - b. On opposite side insert suitable tool (C) into hole (D).
 - c. Depress suitable tools (A) and (C) at the same time and remove seat belt retractor (1) as shown.

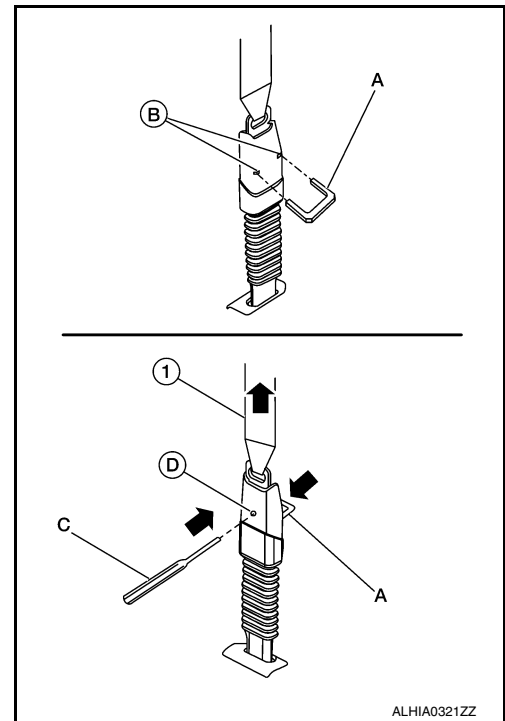

4. Remove the center pillar lower finisher. Refer to [INT-21, "CENTER PILLAR LOWER FINISHER : Removal and Installation"](#).
5. Position floor trim aside and disconnect the harness connector from the lap belt pretensioner.

CAUTION:

- **For removing/installing the shoulder belt pre-tensioner harness connector, insert a thin screwdriver wrapped in tape into the notch, then lift the lock and remove the harness connector as shown.**
- **Install the harness connector with the lock raised, and push the lock into the harness connector as shown.**
- **After installing the harness connector, check that the lock is pushed in securely.**

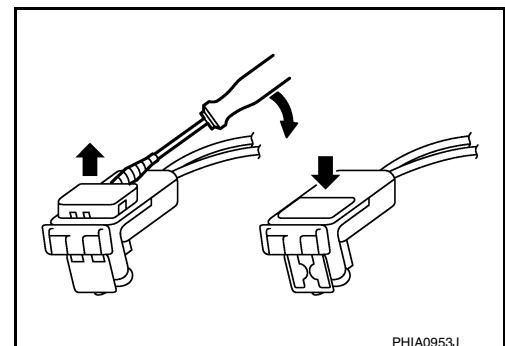

6. Remove floor bracket bolt and floor bracket.
7. Remove lap belt pretensioner bolts and lap belt pretensioner.

FRONT SEAT BELT

< REMOVAL AND INSTALLATION >

Installation

Installation is in the reverse order of removal.

- Tighten the floor bracket bolt and lap belt pretensioner bolts to specification.
- Always perform an inspection after repair to make sure the system is functioning within specifications. Refer to [SB-5, "Inspection"](#).

SEAT BELT HEIGHT ADJUSTER

Removal

1. Slide front seat to the full forward position.
2. Remove the center pillar upper finisher. Refer to [INT-20, "CENTER PILLAR UPPER FINISHER : Removal and Installation"](#).
3. Remove the D-ring anchor nut.
CAUTION:
Before removing the D-ring anchor nut, note the positions of washers and spacers for correct installation.
4. Remove the seat belt height adjuster bolts (A) and the seat belt height adjuster (1).

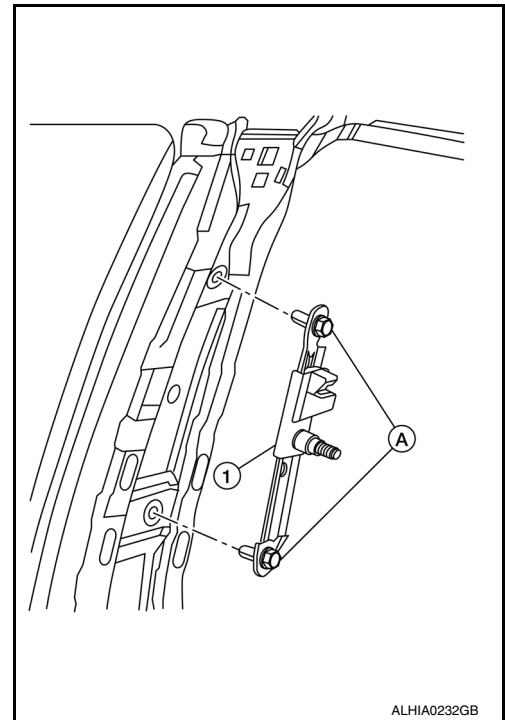

Installation

Installation is in the reverse order of removal.

- Make sure that the seat belt height adjuster is locked in the lowest position and is aligned with the finisher opening during installation.
- Tighten the D-ring anchor nut and seat belt height adjuster bolts to specification.
- Make sure both the D-ring anchor and seat belt height adjuster operate freely.
- Always perform an inspection after repair to make sure the system is functioning within specifications. Refer to [SB-5, "Inspection"](#).

SEAT BELT BUCKLE

Removal

1. Remove the front seat. Refer to [SE-87, "Removal and Installation"](#).
2. Disconnect the harness connector (if equipped) from seat belt buckle.
3. Remove seat belt buckle anchor bolt and the seat belt buckle.
CAUTION:
Before removing the seat belt buckle anchor bolt, note the positions of washers and spacers for correct installation.

FRONT SEAT BELT

< REMOVAL AND INSTALLATION >

Installation

Installation is in the reverse order of removal.

- During installation, make sure the seat belt buckle anchor bolt (A) is inserted through the components in the following order:
 1. Wave washer
 2. Seat belt buckle
 3. Spacer
 4. Star washer

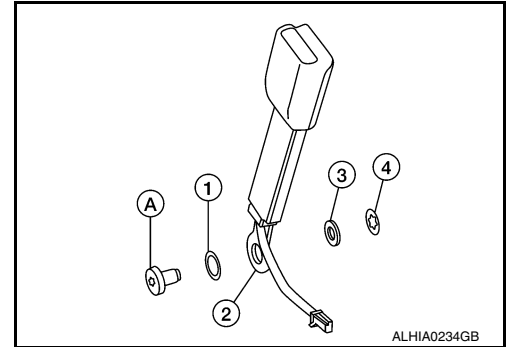

- Tighten the seat belt buckle anchor bolt to specification.
- Always perform an inspection after repair to make sure the system is functioning within specifications. Refer to [SB-5, "Inspection"](#).

SECOND ROW SEAT BELT

< REMOVAL AND INSTALLATION >

SECOND ROW SEAT BELT

Second Row Seat Belt

INFOID:000000011149845

EXPLODED VIEW

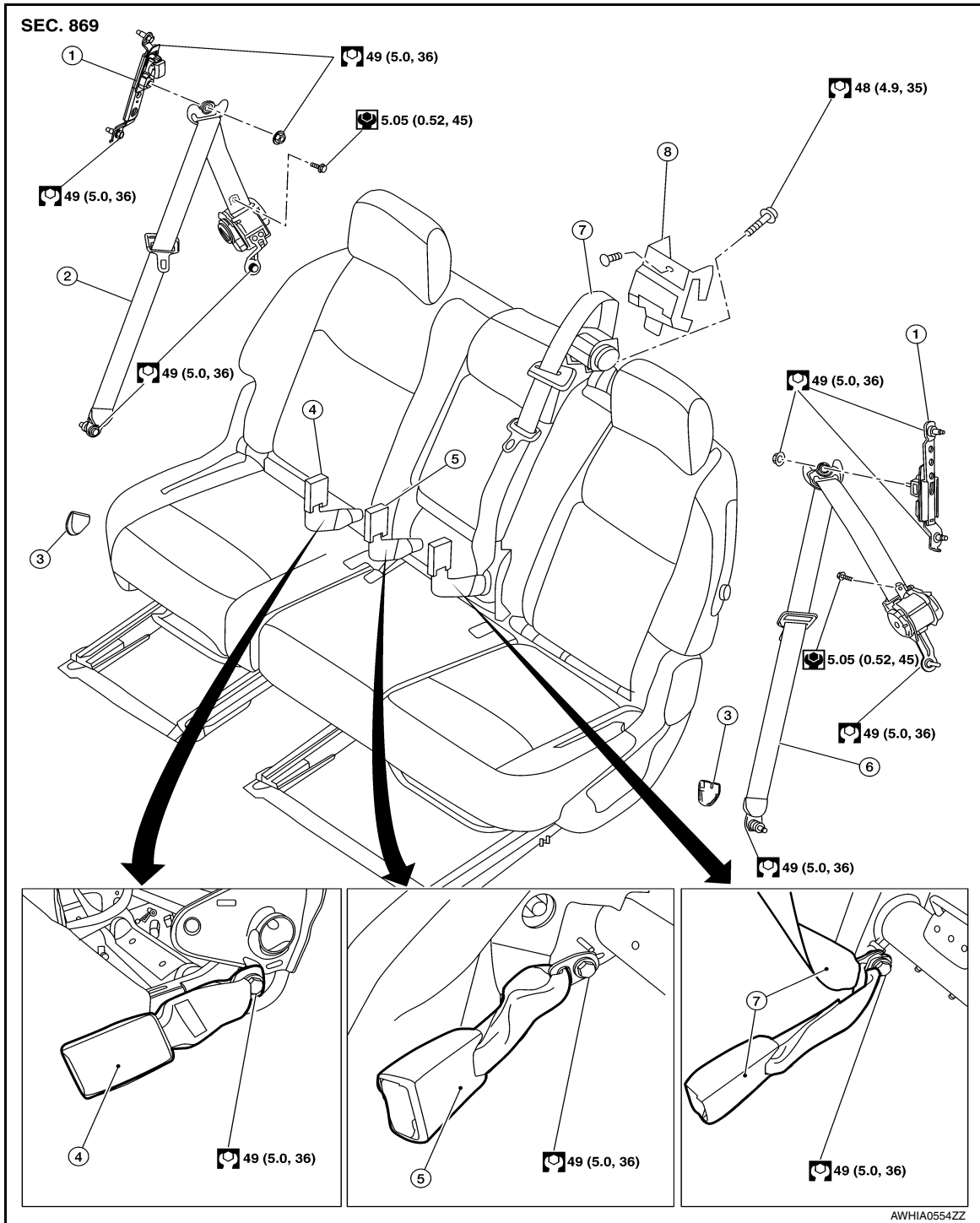

- | | | |
|--------------------------------------|---------------------------------|-----------------------------|
| 1. Seat belt height adjuster (LH/RH) | 2. Seat belt retractor (RH) | 3. Lower anchor bolt cover |
| 4. Seat belt buckle (RH) | 5. Seat belt buckle (center) | 6. Seat belt retractor (LH) |
| 7. Seat belt retractor (center) | 8. Seat belt retractor finisher | |

SEAT BELT RETRACTOR

Removal - Seat Belt Retractor (LH/RH)

Revision: September 2014

SB-13

2015 Pathfinder

A
B
C
D
E
F
G
SB
I
J
K
L
M
N
O
P

SECOND ROW SEAT BELT

< REMOVAL AND INSTALLATION >

1. Remove the lower anchor bolt cover then remove the lower anchor bolt.
CAUTION:
Before removing the lower anchor bolt, note the positions of washers and spacers for correct installation.
2. Remove the rear pillar finisher. Refer to [INT-30, "REAR PILLAR FINISHER : Removal and Installation"](#).
3. Remove the D-ring anchor nut.
CAUTION:
Before removing the D-ring anchor nut, note the positions of washers and spacers for correct installation.
4. Remove the upper bolt (B), then bolt (A) and the seat belt retractor (1).

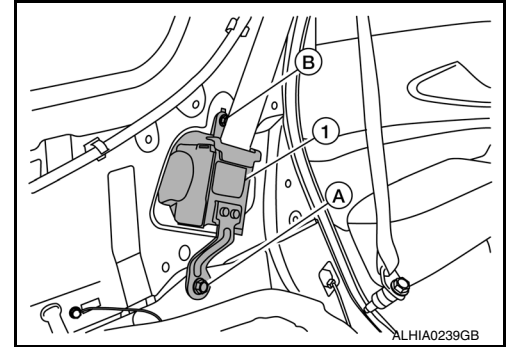

Installation

Installation is in the reverse order of removal.

- Make sure that the seat belt height adjuster is locked in the lowest position and is aligned with the finisher opening during installation.
- Tighten the D-ring anchor bolt, seat belt retractor bolts, and lower anchor bolt to specification.
- Make sure both the D-ring anchor and seat belt height adjuster operate freely.
- Always perform an inspection after repair to make sure the system is functioning within specifications. Refer to [SB-5, "Inspection"](#).

Removal - Seat Belt Retractor (center)

1. Remove the LH seatback pad and seatback trim as an assembly from the seat frame assembly. Refer to [SE-132, "LH SEAT : Seatback"](#).
2. Remove screw (A) and seat belt retractor finisher (1).

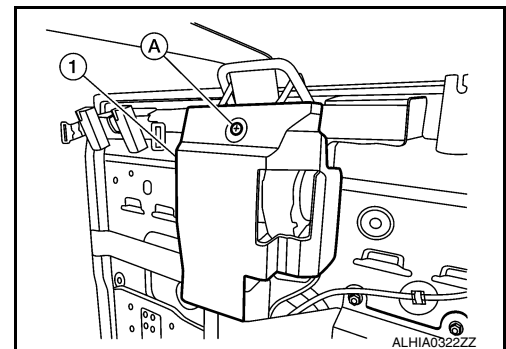

3. Remove bolt (A) and the seat belt retractor (center).

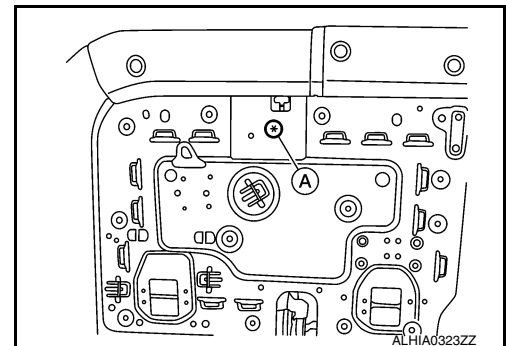

Installation

SECOND ROW SEAT BELT

< REMOVAL AND INSTALLATION >

Installation is in the reverse order of removal.

- Tighten the seat belt retractor bolt to specification.
- Always perform an inspection after repair to make sure the system is functioning within specifications. Refer to [SB-5. "Inspection"](#).

SEAT BELT HEIGHT ADJUSTER

Removal

1. Remove the rear pillar finisher. Refer to [INT-30. "REAR PILLAR FINISHER : Removal and Installation"](#).
2. Remove the D-ring anchor nut.
3. Remove the seat belt height adjuster bolts and the seat belt height adjuster.

Installation

Installation is in the reverse order of removal.

- Make sure that the seat belt height adjuster is locked in the lowest position and is aligned with the finisher opening during installation.
- Make sure both the D-ring anchor and seat belt height adjuster operate freely.

SEAT BELT BUCKLE (RH)

Removal

1. Slide the second row LH seat to the full forward position and move the second row RH seat to the full rearward position.
2. Remove outer finisher (LH) (1).

- : Pawl
- △: Clip

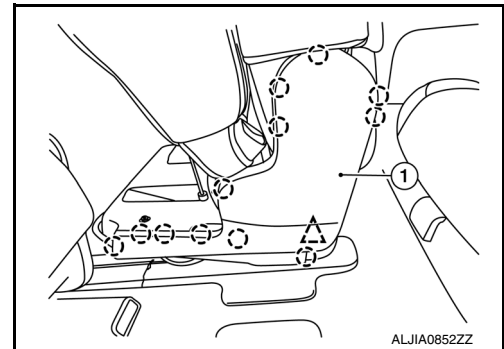

3. Remove seat belt buckle (RH) anchor bolt (A).
4. Route the seat belt buckle (RH) (1) through the opening in the seat cushion trim (2) and behind inner finisher (LH) (3).

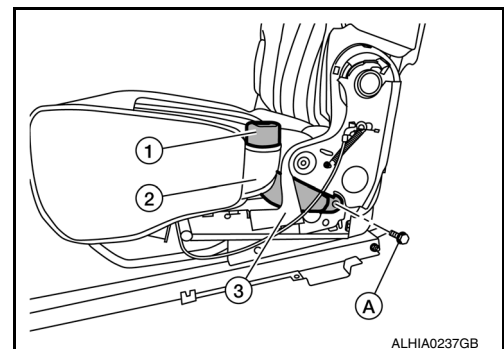

Installation

Installation is in the reverse order of removal.

- Tighten the seat belt buckle anchor bolt to specification.
- Always perform an inspection after repair to make sure the system is functioning within specifications. Refer to [SB-5. "Inspection"](#).

SEAT BELT BUCKLE (center)

Removal

SECOND ROW SEAT BELT

< REMOVAL AND INSTALLATION >

1. Remove the seat belt buckle (center) anchor bolt from behind the LH seat (1) using a suitable tool (A).
↳ Front

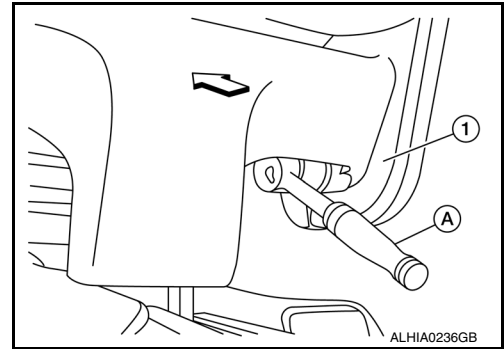

2. Route the seat belt buckle (center) (1) through the opening in the seat cushion trim (2) and remove.
↳ Front

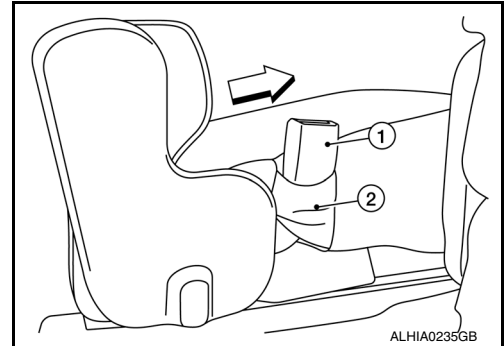

Installation

Installation is in the reverse order of removal.

- Tighten the seat belt buckle anchor bolt to specification.
- Always perform an inspection after repair to make sure the system is functioning within specifications. Refer to [SB-5, "Inspection"](#).

THIRD ROW SEAT BELT

< REMOVAL AND INSTALLATION >

THIRD ROW SEAT BELT

Third Row Seat Belt

INFOID:000000011149846

EXPLODED VIEW

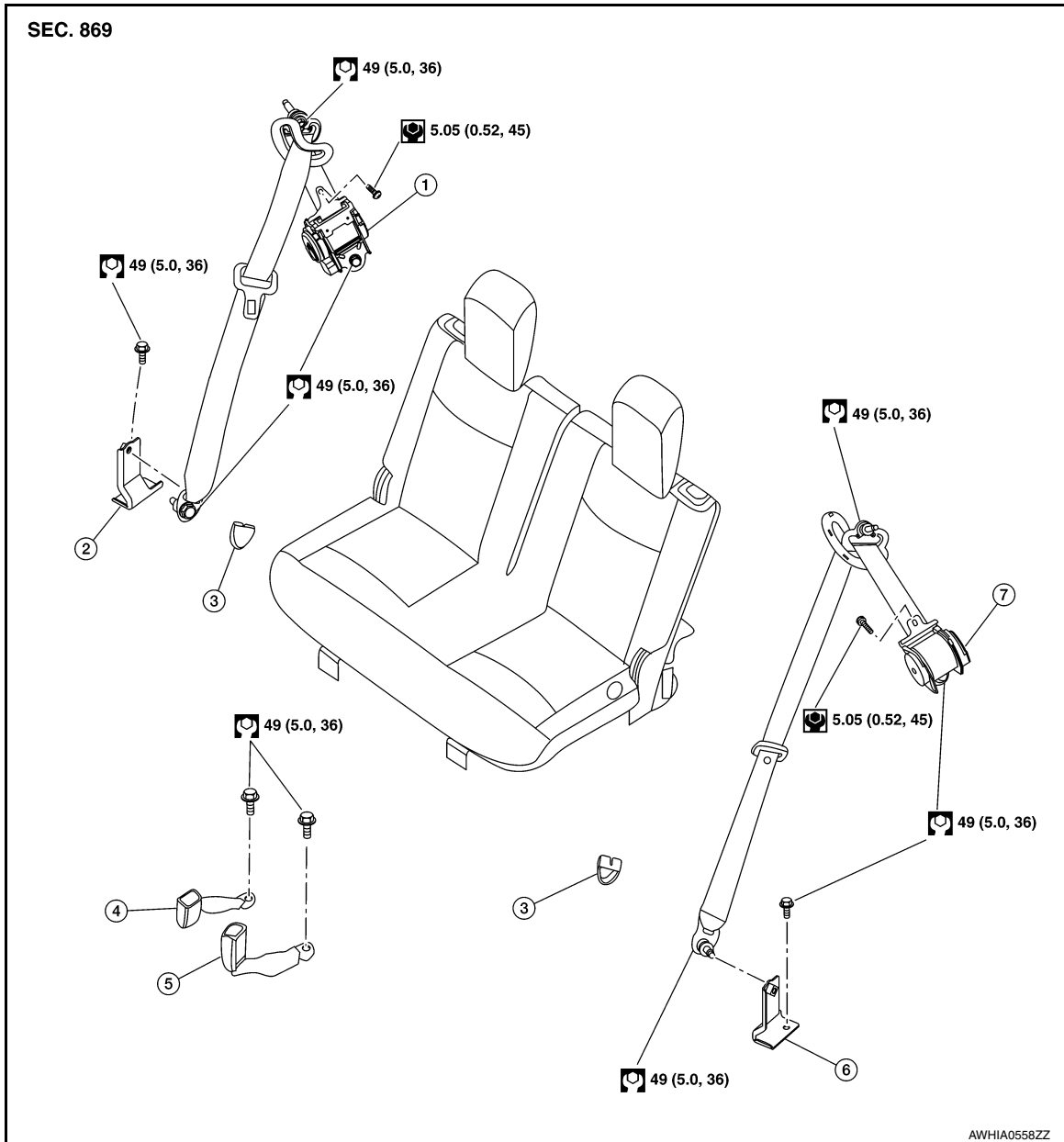

- | | | |
|-----------------------------|------------------------------|------------------------------------|
| 1. Seat belt retractor (RH) | 2. Lower anchor bracket (RH) | 3. Lower anchor bolt cover (LH/RH) |
| 4. Seat belt buckle (RH) | 5. Seat belt buckle (LH) | 6. Lower anchor bracket (LH) |
| 7. Seat belt retractor (LH) | | |

SEAT BELT RETRACTOR

Removal

1. Remove the third row seat. Refer to [SE-113. "Removal and Installation"](#).
2. Pull back the lower anchor bolt cover and remove the seat belt lower anchor bolt.

CAUTION:

Before removing the seat belt lower anchor bolt, note the positions of washers and spacers for correct installation.

THIRD ROW SEAT BELT

< REMOVAL AND INSTALLATION >

3. Remove the back pillar finisher. Refer to [INT-32, "BACK PILLAR FINISHER : Removal and Installation"](#).
4. Remove the D-ring anchor bolt.
CAUTION:
Before removing the D-ring anchor bolt, note the positions of washers and spacers for correct installation.
5. Remove the seat belt retractor bolts and the seat belt retractor.

Installation

Installation is in the reverse order of removal.

- Tighten the D-ring anchor bolt, seat belt lower anchor bolt, and the seat belt retractor bolts to specification.
- Make sure the D-ring anchor operates freely.
- Always perform an inspection after repair to make sure the system is functioning within specifications. Refer to [SB-5, "Inspection"](#).

SEAT BELT BUCKLE

Removal

1. Open the storage box lid (1).
2. Remove spare tire compartment lid and the spare tire jack assembly (2).

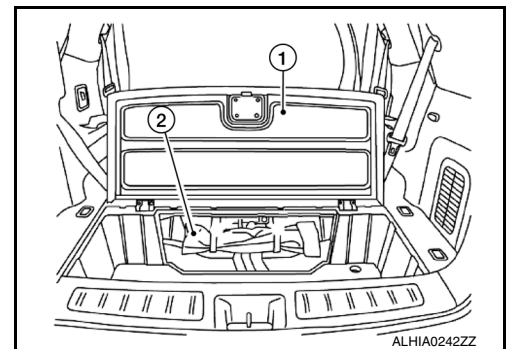

3. Remove the seat belt buckle anchor bolt (A).
↳ Front
4. Route the seat belt buckle (1) through the opening in the seat cushion trim and remove.

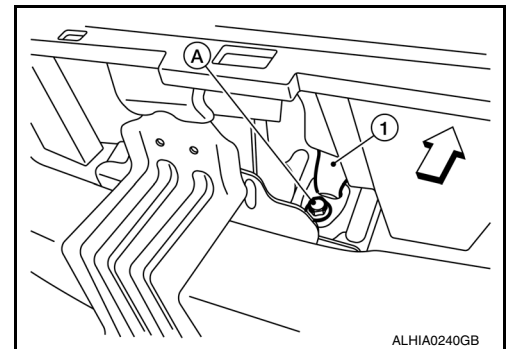

Installation

Installation is in the reverse order of removal.

- Tighten the seat belt buckle anchor bolt to specification.
- Always perform an inspection after repair to make sure the system is functioning within specifications. Refer to [SB-5, "Inspection"](#).

LATCH (LOWER ANCHORS AND TETHER FOR CHILDREN) SYSTEM

< REMOVAL AND INSTALLATION >

LATCH (LOWER ANCHORS AND TETHER FOR CHILDREN) SYSTEM

Removal and Installation

INFOID:000000011149847

The LATCH (Lower Anchors and Tether for Children) system is not serviceable.

A

B

C

D

E

F

G

SB

I

J

K

L

M

N

O

P

TOP TETHER STRAP CHILD RESTRAINT

< REMOVAL AND INSTALLATION >

TOP TETHER STRAP CHILD RESTRAINT

Removal and Installation

INFOID:000000011149848

The Top Tether Strap Child Restraint system is not serviceable.