

A

SECTION STR

STR

STARTING SYSTEM

C

CONTENTS

D

PRECAUTION	2	DIAGNOSIS AND REPAIR WORKFLOW	10	
PRECAUTIONS	2	Work Flow (With GR8-1200 NI)	10	
Precaution for Supplemental Restraint System (SRS) "AIR BAG" and "SEAT BELT PRE-TENSIONER"	2	Work Flow (Without GR8-1200 NI)	14	
PREPARATION	3	DTC/CIRCUIT DIAGNOSIS	16	E
PREPARATION	3	B TERMINAL CIRCUIT	16	
Special Service Tool	3	Description	16	F
Commercial Service Tools	3	Diagnosis Procedure	16	
SYSTEM DESCRIPTION	4	S CONNECTOR CIRCUIT	18	G
COMPONENT PARTS	4	Description	18	
Component Parts Location	4	Diagnosis Procedure	18	H
Component Description	4	SYMPTOM DIAGNOSIS	19	
STARTING SYSTEM	5	STARTING SYSTEM	19	I
System Diagram	5	Symptom Table	19	
System Description	5	REMOVAL AND INSTALLATION	20	J
WIRING DIAGRAM	6	STARTER MOTOR	20	
STARTING SYSTEM	6	Exploded View	20	K
Wiring Diagram	6	Removal and Installation	20	
BASIC INSPECTION	10	SERVICE DATA AND SPECIFICATIONS (SDS)	21	L
		STARTER MOTOR	21	
		Starter	21	M

O

P

PRECAUTIONS

< PRECAUTION >

PRECAUTION

PRECAUTIONS

Precaution for Supplemental Restraint System (SRS) "AIR BAG" and "SEAT BELT PRE-TENSIONER"

INFOID:000000011153295

The Supplemental Restraint System such as "AIR BAG" and "SEAT BELT PRE-TENSIONER", used along with a front seat belt, helps to reduce the risk or severity of injury to the driver and front passenger for certain types of collision. Information necessary to service the system safely is included in the SR and SB section of this Service Manual.

WARNING:

- To avoid rendering the SRS inoperative, which could increase the risk of personal injury or death in the event of a collision which would result in air bag inflation, all maintenance must be performed by an authorized NISSAN/INFINITI dealer.
- Improper maintenance, including incorrect removal and installation of the SRS, can lead to personal injury caused by unintentional activation of the system. For removal of Spiral Cable and Air Bag Module, see the SR section.
- Do not use electrical test equipment on any circuit related to the SRS unless instructed to in this Service Manual. SRS wiring harnesses can be identified by yellow and/or orange harnesses or harness connectors.

PRECAUTIONS WHEN USING POWER TOOLS (AIR OR ELECTRIC) AND HAMMERS

WARNING:

- When working near the Airbag Diagnosis Sensor Unit or other Airbag System sensors with the Ignition ON or engine running, DO NOT use air or electric power tools or strike near the sensor(s) with a hammer. Heavy vibration could activate the sensor(s) and deploy the air bag(s), possibly causing serious injury.
- When using air or electric power tools or hammers, always switch the Ignition OFF, disconnect the battery and wait at least three minutes before performing any service.

PREPARATION

< PREPARATION >

PREPARATION

PREPARATION

Special Service Tool

INFOID:000000011153296

A

STR

The actual shape of the tools may differ from those illustrated here.

Tool number (TechMate No.) Tool name	Description
<p>— (—) Model GR8-1200 NI Multitasking battery and electrical diagnostic station</p>  <p style="text-align: right;">AWIIA1239ZZ</p>	<p>Tests batteries, starting and charging systems and charges batteries. For operating instructions, refer to diagnostic station instruction manual.</p>

C

D

E

Commercial Service Tools

INFOID:000000011153297

Tool name	Description
<p>Power tool</p>  <p style="text-align: right;">PIIB1407E</p>	<p>Loosening nuts, screws and bolts</p>

F

G

H

I

J

K

L

M

N

O

P

COMPONENT PARTS

< SYSTEM DESCRIPTION >

SYSTEM DESCRIPTION

COMPONENT PARTS

Component Parts Location

INFOID:0000000011153298

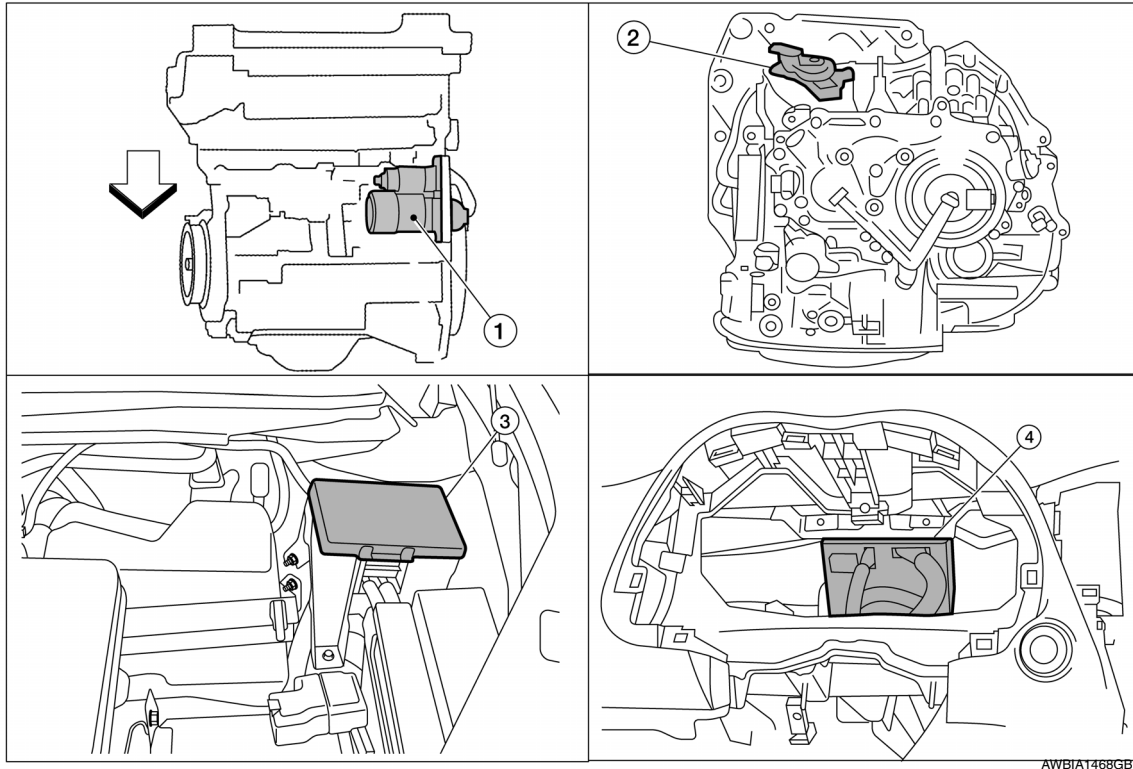

↶ Vehicle front

- 1. Starter motor
- 2. Transmission range switch
- 3. IPDM E/R
- 4. BCM (view with combination meter removed)

Component Description

INFOID:0000000011153299

Component part	Description
BCM	BCM controls the starter relay inside IPDM E/R.
Transmission range switch	Transmission range switch supplies power to the starter relay and starter control relay inside the IPDM E/R when the selector lever is shifted to the P (Park) or N (Neutral) position.
IPDM E/R	CPU inside IPDM E/R operates the starter relay when the ignition switch is in the start position.
Starter motor	The starter motor plunger closes and the motor is supplied with battery power, which in turn cranks the engine, when the S terminal is supplied with electric power.

STARTING SYSTEM

< SYSTEM DESCRIPTION >

STARTING SYSTEM

System Diagram

INFOID:000000011153300

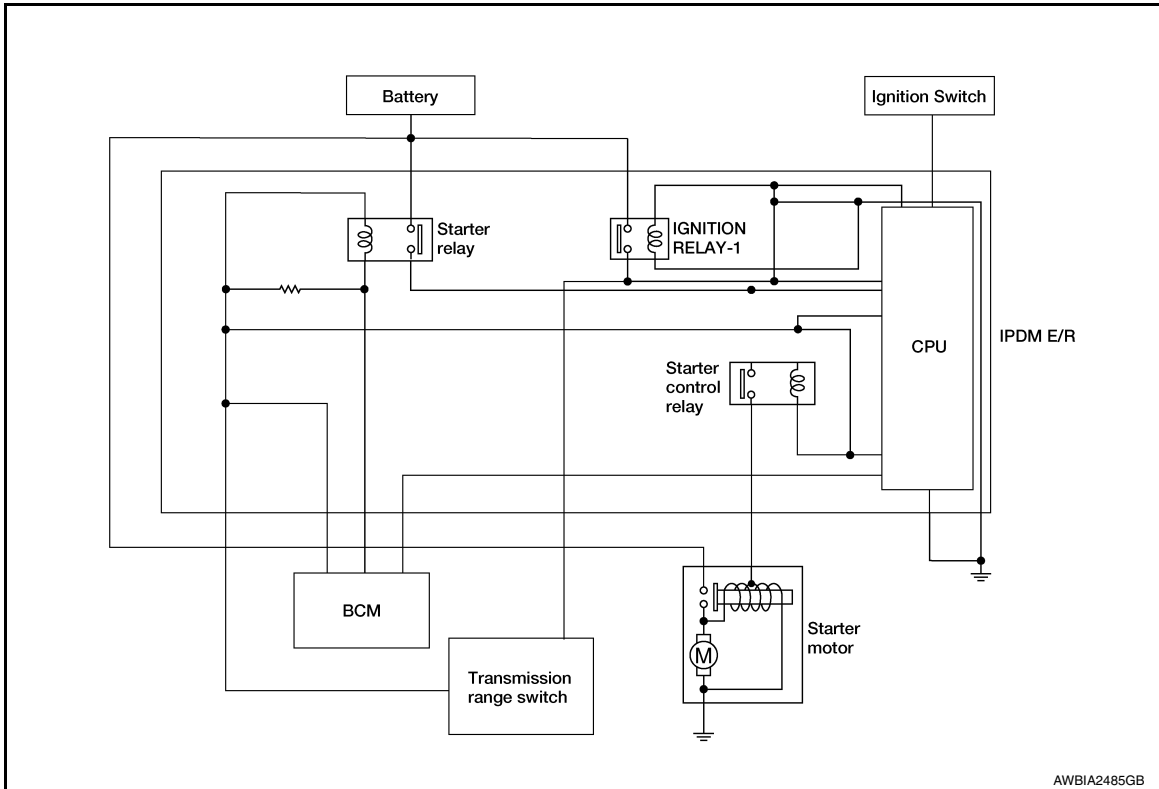

System Description

INFOID:000000011153301

The starter motor plunger closes and provides a closed circuit between the battery and the starter motor. The starter motor is grounded to the cylinder block. With power and ground supplied, the starter motor operates.

A
STR
C
D
E
F
G
H
I
J
K
L
M
N
O
P

STARTING SYSTEM

< WIRING DIAGRAM >

WIRING DIAGRAM

STARTING SYSTEM

Wiring Diagram

INFOID:000000011153302

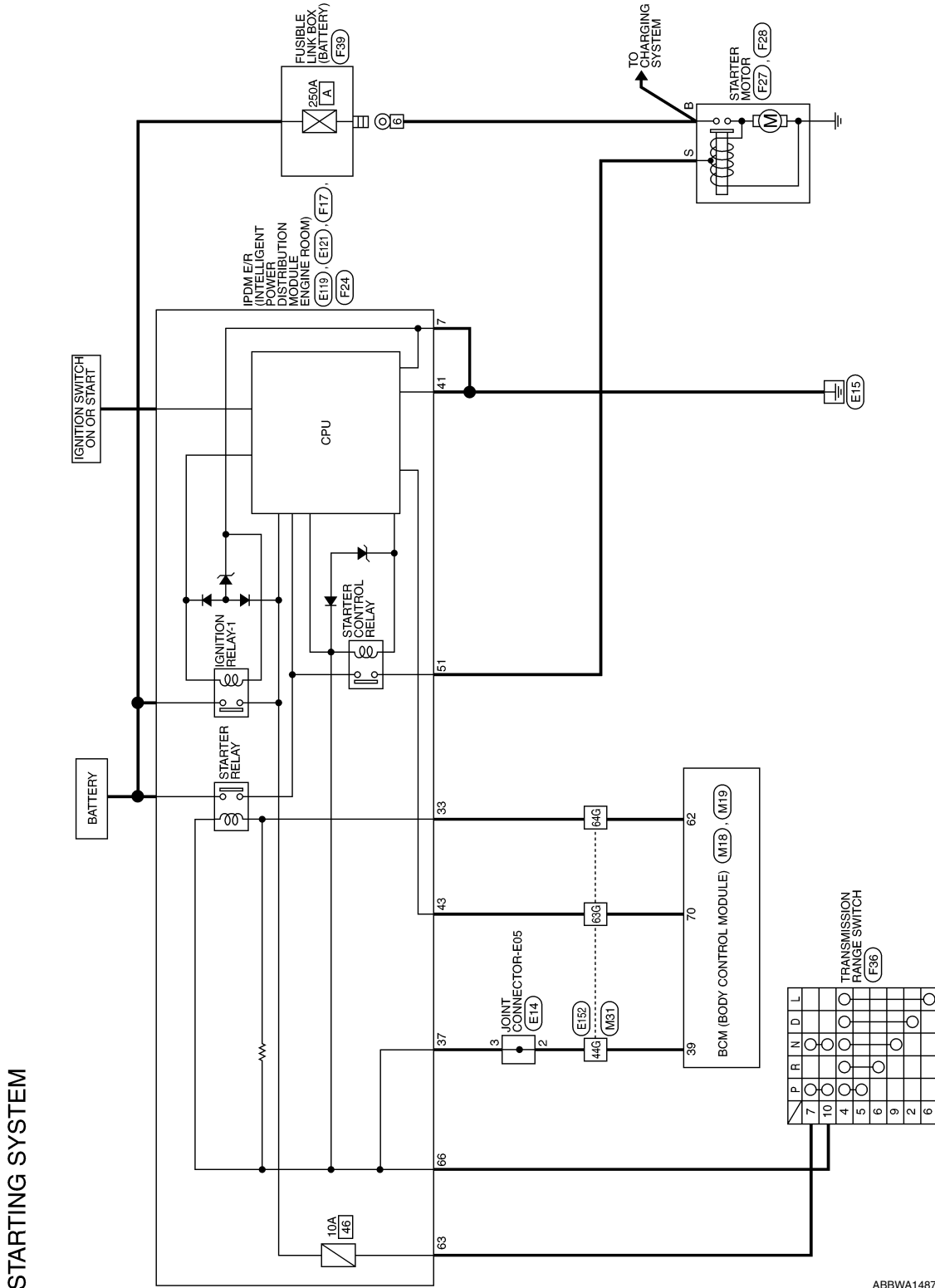

ABBWA1487GB

STARTING SYSTEM

< WIRING DIAGRAM >

STARTING SYSTEM CONNECTORS

Connector No.	M18
Connector Name	BCM (BODY CONTROL MODULE)
Connector Color	GREEN



20	19	18	17	16	15	14	13	12	11	10	9	8	7	6	5	4	3	2	1
40	39	38	37	36	35	34	33	32	31	30	29	28	27	26	25	24	23	22	21

Terminal No.	Color of Wire	Signal Name
39	G	SHIFT N/P

Connector No.	M19
Connector Name	BCM (BODY CONTROL MODULE)
Connector Color	BLACK



60	59	58	57	56	55	54	53	52	51	50	49	48	47	46	45	44	43	42	41
80	79	78	77	76	75	74	73	72	71	70	69	68	67	66	65	64	63	62	61

Terminal No.	Color of Wire	Signal Name
62	W	STARTER RELAY OUT
70	P	IGN USM OUT 1

Connector No.	M31
Connector Name	WIRE TO WIRE
Connector Color	WHITE

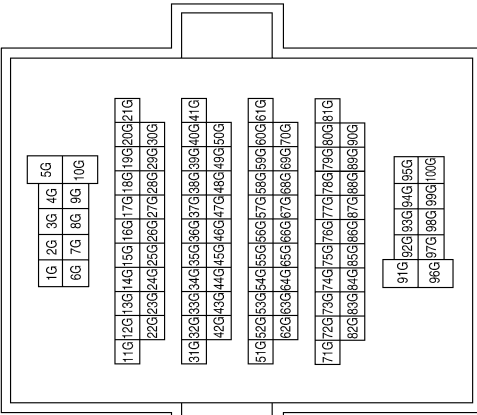

Terminal No.	Color of Wire	Signal Name
44G	G	-
63G	P	-
64G	W	-

Connector No.	E14
Connector Name	JOINT CONNECTOR-E05
Connector Color	BLACK



12	11	10	9	8	7	6	5	4	3	2	1
----	----	----	---	---	---	---	---	---	---	---	---

Terminal No.	Color of Wire	Signal Name
2	W	-
3	W	-

ABBIA1757GB

A
STR
C
D
E
F
G
H
I
J
K
L
M
N
O
P

STARTING SYSTEM

< WIRING DIAGRAM >

Connector No.	E121
Connector Name	IPDM E/R (INTELLIGENT POWER DISTRIBUTION MODULE ENGINE ROOM)
Connector Color	WHITE

7	8	9	10	11
12	13	14	15	16
17	18			



Terminal No.	Color of Wire	Signal Name
7	B	GND (POWER)

Connector No.	E119
Connector Name	IPDM E/R (INTELLIGENT POWER DISTRIBUTION MODULE ENGINE ROOM)
Connector Color	WHITE

19	20	21	22	23	24	25	26	27	28	29	30	31	32	33	34
35	36	37	38	39	40	41	42	43	44	45	46	47	48	49	50



Terminal No.	Color of Wire	Signal Name
33	R	START CONT
37	W	CLUTCH I/L SW
41	B	GND (SIGNAL)
43	L	IGN SIGNAL

Connector No.	F17
Connector Name	IPDM E/R (INTELLIGENT POWER DISTRIBUTION MODULE ENGINE ROOM)
Connector Color	BLACK

51



Terminal No.	Color of Wire	Signal Name
51	W	STARTER MOTOR

Terminal No.	Color of Wire	Signal Name
44G	W	-
63G	L	-
64G	R	-

Connector No.	E152
Connector Name	WIRE TO WIRE
Connector Color	WHITE

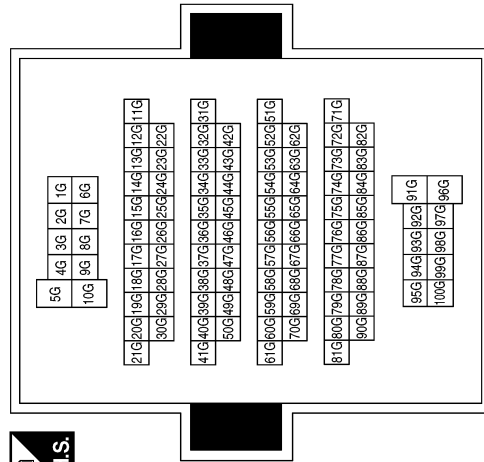

ABBIA2725GB

STARTING SYSTEM

< WIRING DIAGRAM >

Connector No.	F28
Connector Name	STARTER MOTOR
Connector Color	GRAY



Terminal No.	Color of Wire	Signal Name
S	W	-

Connector No.	F27
Connector Name	STARTER MOTOR
Connector Color	-



Terminal No.	Color of Wire	Signal Name
B	B/R	-

Connector No.	F24
Connector Name	IPDM E/R (INTELLIGENT POWER DISTRIBUTION MODULE ENGINE ROOM)
Connector Color	WHITE

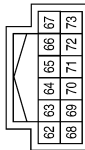

Terminal No.	Color of Wire	Signal Name
63	L	INHIBIT SW
66	G	NP SW

Connector No.	F39
Connector Name	FUSIBLE LINK BOX (BATTERY)
Connector Color	-



Terminal No.	Color of Wire	Signal Name
6	B/R	-

Connector No.	F36
Connector Name	TRANSMISSION RANGE SWITCH
Connector Color	BLACK

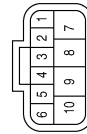

Terminal No.	Color of Wire	Signal Name
7	L	-
10	G	-

ABBIA1759GB

A
STR

C

D

E

F

G

H

I

J

K

L

M

N

O

P

DIAGNOSIS AND REPAIR WORKFLOW

< BASIC INSPECTION >

BASIC INSPECTION

DIAGNOSIS AND REPAIR WORKFLOW

Work Flow (With GR8-1200 NI)

INFOID:000000011153303

STARTING SYSTEM DIAGNOSIS WITH GR8-1200 NI

To test the starting system, use the following special service tool:

- GR8-1200 NI Multitasking battery and electrical diagnostic station

NOTE:

Refer to the diagnostic station Instruction Manual for proper starting system diagnosis procedures.

DIAGNOSIS AND REPAIR WORKFLOW

< BASIC INSPECTION >

OVERALL SEQUENCE

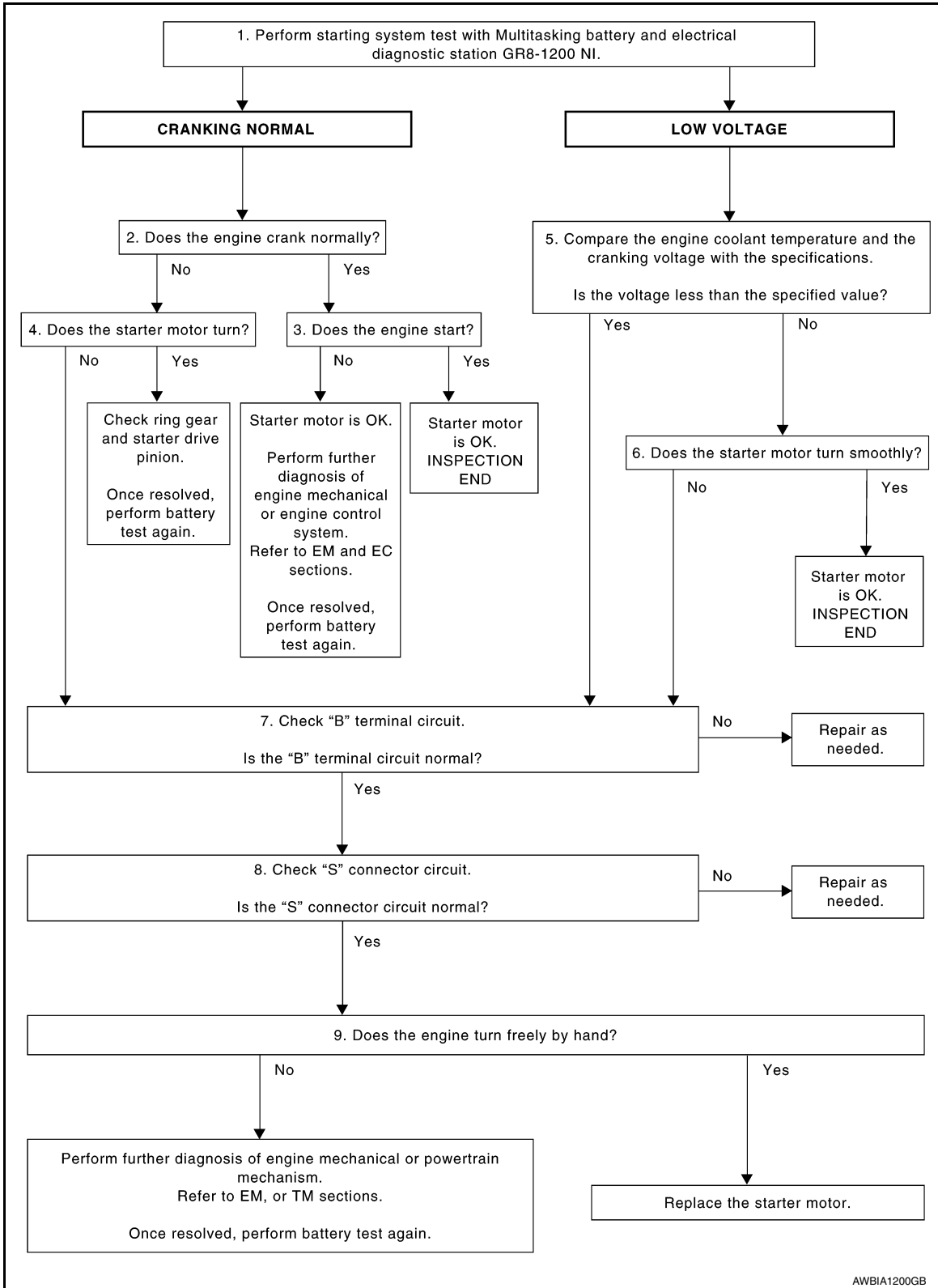

DETAILED FLOW

NOTE:

To ensure a complete and thorough diagnosis, the battery, starter motor and generator test segments must be done as a set from start to finish.

1. DIAGNOSIS WITH MULTITASKING BATTERY AND ELECTRICAL DIAGNOSTIC STATION GR8-1200 NI

DIAGNOSIS AND REPAIR WORKFLOW

< BASIC INSPECTION >

Perform the starting system test with Multitasking battery and electrical diagnostic station GR8-1200 NI. For details and operating instructions, refer to diagnostic station Instruction Manual.

Test result

CRANKING NORMAL>>GO TO 2.

LOW VOLTAGE>>GO TO 5.

CHARGE BATTERY>>Perform the slow battery charging procedure. (Initial rate of charge is 10A for 12 hours.) Perform battery test again. Refer to diagnostic station instruction manual.

REPLACE BATTERY>>Before replacing battery, clean the battery cable clamps and battery posts. Perform battery test again. Refer to diagnostic station instruction manual. If second test result is "REPLACE BATTERY", then do so. Perform battery test again to confirm repair.

2. CRANKING CHECK

Check that the starter motor operates properly.

Does the engine crank normally?

YES >> GO TO 3.

NO >> GO TO 4.

3. ENGINE START CHECK

Check that the engine starts.

Does the engine start?

YES >> Inspection End.

NO >> Perform further diagnosis of engine mechanical or engine control system. Refer to EM and EC sections. Once resolved, perform battery test again.

4. STARTER MOTOR ACTIVATION

Check that the starter motor operates.

Does the starter motor turn?

YES >> Check ring gear and starter motor drive pinion. Once resolved, perform battery test again.

NO >> GO TO 7.

5. COMPARISON BETWEEN ENGINE COOLANT AND CRANKING VOLTAGE

Compare the engine coolant temperature and verify the cranking voltage is within specifications.

Minimum Specification of Cranking Voltage Referencing Coolant Temperature

Engine coolant temperature [°C (°F)]	Voltage [V]
-30 to -20 (-22 to -4)	8.6
-19 to -10 (-2 to 14)	9.1
-9 to 0 (16 to 32)	9.5
More than 1 (More than 34)	9.9

Is the voltage less than the specified value?

YES >> GO TO 7.

NO >> GO TO 6.

6. STARTER OPERATION

Check the starter operation.

Does the starter motor turn smoothly?

YES >> Inspection End.

NO >> GO TO 7.

7. "B" TERMINAL CIRCUIT INSPECTION

Check "B" terminal circuit. Refer to [STR-16, "Diagnosis Procedure"](#).

Is "B" terminal circuit normal?

YES >> GO TO 8.

NO >> Repair as needed.

8. "S" CONNECTOR CIRCUIT INSPECTION

Check "S" connector circuit. Refer to [STR-18, "Diagnosis Procedure"](#).

DIAGNOSIS AND REPAIR WORKFLOW

< BASIC INSPECTION >

Is "S" connector circuit normal?

YES >> GO TO 9.

NO >> Repair as needed.

A

9. ENGINE ROTATION STATUS

Check that the engine can be rotated by hand.

Does the engine turn freely by hand?

YES >> Replace starter motor.

NO >> Perform further diagnosis of engine mechanical or powertrain mechanism. Once resolved, perform battery test again using Multitasking battery and electrical diagnostic station GR8-1200 NI. Refer to the diagnostic station Instruction Manual for proper testing procedures.

STR

C

D

E

F

G

H

I

J

K

L

M

N

O

P

DIAGNOSIS AND REPAIR WORKFLOW

< BASIC INSPECTION >

Work Flow (Without GR8-1200 NI)

INFOID:000000011153304

OVERALL SEQUENCE

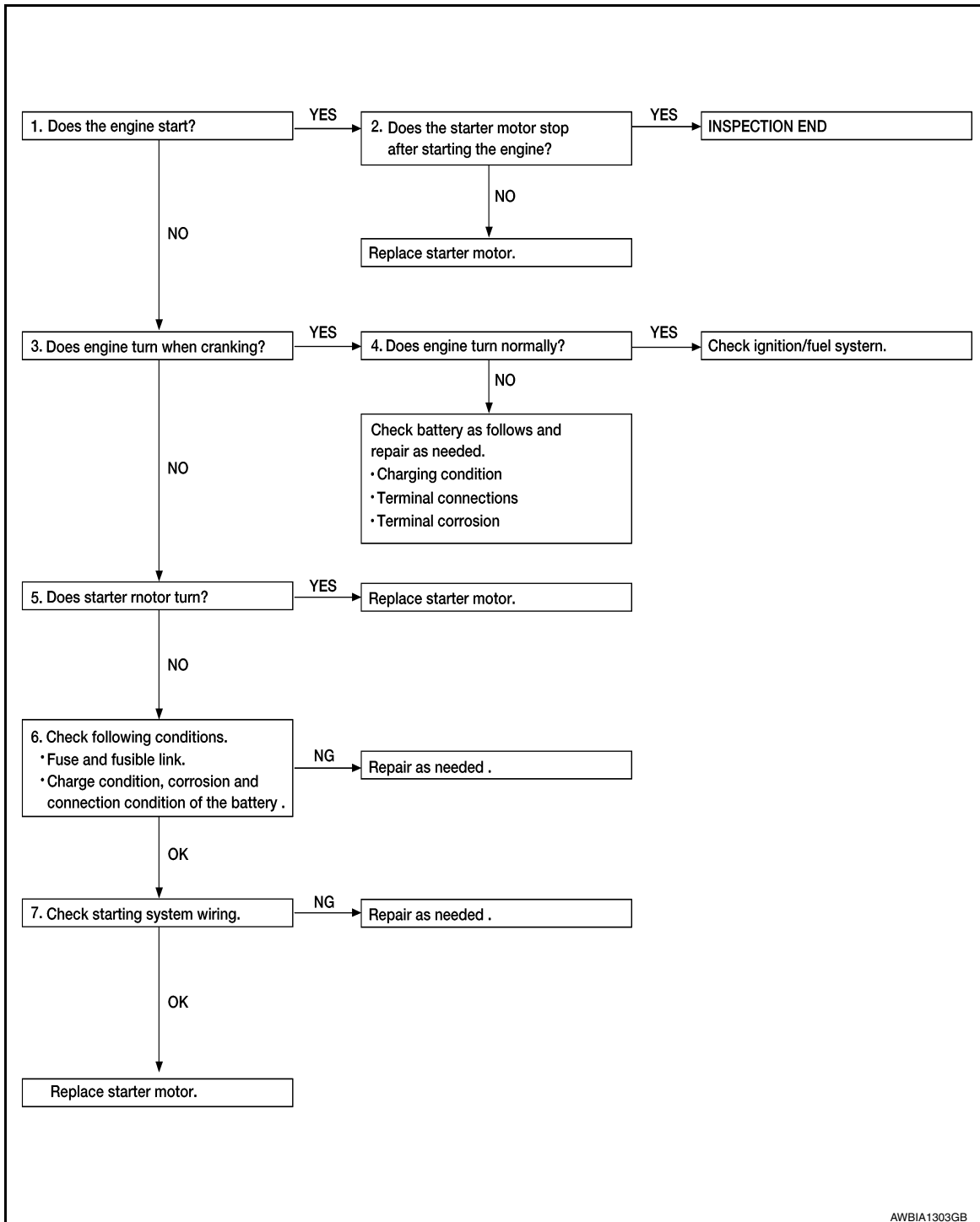

DETAILED FLOW

NOTE:

If any malfunction is found, immediately disconnect the battery cable from the negative terminal.

1. CHECK ENGINE START

Crank the engine and check that the engine starts.

Does the engine start?

YES >> GO TO 2.

NO >> GO TO 3.

DIAGNOSIS AND REPAIR WORKFLOW

< BASIC INSPECTION >

2. CHECK THAT THE STARTER MOTOR STOPS

Check that the starter motor stops after starting the engine.

Does the starter motor stop?

YES >> Inspection End.

NO >> Replace starter motor. Refer to [STR-20. "Removal and Installation"](#).

3. CHECK THAT THE ENGINE TURNS WHEN CRANKING

Check that the engine turns when cranking.

Does engine turn when cranking?

YES >> GO TO 4.

NO >> GO TO 5.

4. CHECK THE ENGINE SPEED WHEN CRANKING

Check that the engine speed is not low when cranking.

Does engine turn normally?

YES >> Check ignition/fuel system.

NO >> Check charge condition, corrosion and connection condition of the battery. Refer to [PG-86. "How to Handle Battery"](#).

5. CHECK STARTER MOTOR ACTIVATION

Check that the starter motor runs at cranking.

Does starter motor turn?

YES >> Replace starter motor. Refer to [STR-20. "Removal and Installation"](#).

NO >> GO TO 6.

6. CHECK POWER SUPPLY CIRCUIT

Check the following conditions:

- Fuse and fusible link
- Charge condition, corrosion and connection of the battery.

Are these inspection results normal?

YES >> GO TO 7.

NO >> Repair as needed.

7. CHECK STARTING SYSTEM WIRING

Check the following:

- "B" terminal circuit. Refer to [STR-16. "Diagnosis Procedure"](#).
- "S" terminal circuit. Refer to [STR-18. "Diagnosis Procedure"](#).

Are the inspection results normal?

YES >> Replace starter motor. Refer to [STR-20. "Removal and Installation"](#).

NO >> Repair as needed.

A

STR

C

D

E

F

G

H

I

J

K

L

M

N

O

P

B TERMINAL CIRCUIT

< DTC/CIRCUIT DIAGNOSIS >

DTC/CIRCUIT DIAGNOSIS

B TERMINAL CIRCUIT

Description

INFOID:0000000011153305

Terminal "B" is constantly supplied with battery power.

Diagnosis Procedure

INFOID:0000000011153306

Regarding Wiring Diagram information, refer to [STR-6. "Wiring Diagram"](#).

CAUTION:

Perform diagnosis under the condition that the engine cannot start by the following procedure.

1. **Remove fuel pump fuse.**
2. **Crank or start the engine (where possible) until the fuel pressure is released.**

1. CHECK "B" TERMINAL CIRCUIT

1. Turn ignition switch OFF.
2. Check that starter motor "B" terminal connection is clean and tight.
3. Check voltage between starter motor "B" terminal and ground.

Terminals			Voltage (Approx.)
(+)	(-)		
Starter motor "B" terminal F27	Terminal B	Ground	Battery voltage

Is the inspection result normal?

YES >> GO TO 2.

NO >> Check harness between battery and starter motor for open circuit.

2. CHECK BATTERY CABLE CONNECTION STATUS (VOLTAGE DROP TEST)

1. Shift selector lever to "P" (Park) or "N" (Neutral) position.
2. Check voltage between battery positive terminal and starter motor "B" terminal.

Terminals			Condition	Voltage (Approx.)
(+)	(-)			
Battery positive terminal	Starter motor "B" terminal F27	Terminal B	When the ignition switch is in START position	Less than 0.5V

Is the inspection result normal?

YES >> GO TO 3.

NO >> Check harness between the battery and starter motor for continuity.

3. CHECK GROUND CIRCUIT STATUS (VOLTAGE DROP TEST)

1. Shift selector lever to "P" (Park) or "N" (Neutral) position.
2. Check voltage between starter motor case and battery negative terminal.

Terminals		Condition	Voltage (Approx.)
(+)	(-)		
Starter motor case	Battery negative terminal	When the ignition switch is in START position	Less than 0.2V

Is the inspection result normal?

B TERMINAL CIRCUIT

< DTC/CIRCUIT DIAGNOSIS >

- YES >> "B" terminal circuit is OK. Further inspection is necessary. Refer to [STR-10, "Work Flow \(With GR8-1200 NI\)"](#) or [STR-14, "Work Flow \(Without GR8-1200 NI\)"](#).
- NO >> Check the starter motor case to engine mounting for high resistance.

A

STR

C

D

E

F

G

H

I

J

K

L

M

N

O

P

S CONNECTOR CIRCUIT

< DTC/CIRCUIT DIAGNOSIS >

S CONNECTOR CIRCUIT

Description

INFOID:0000000011153307

The starter motor magnetic switch is supplied with power when the ignition switch is turned to the START position while the selector lever is in the P (Park) or N (Neutral) position.

Diagnosis Procedure

INFOID:0000000011153308

Regarding Wiring Diagram information, refer to [STR-6, "Wiring Diagram"](#).

CAUTION:

Perform diagnosis under the condition that engine cannot start by the following procedure.

1. Remove fuel pump fuse.
2. Crank or start the engine (where possible) until the fuel pressure is released.

1. CHECK "S" CONNECTOR CIRCUIT

1. Turn ignition switch OFF.
2. Disconnect starter motor connector.
3. Shift selector lever to "P" (Park) or "N" (Neutral) position.
4. Check voltage between starter motor harness connector and ground.

(+)		(-)	Condition	Voltage (Approx.)
Connector	Terminal			
F28	S	Ground	When the ignition switch is in START position	Battery voltage

Is the inspection result normal?

YES >> "S" circuit is OK. Further inspection is necessary. Refer to [STR-10, "Work Flow \(With GR8-1200 NI\)"](#) or [STR-14, "Work Flow \(Without GR8-1200 NI\)"](#).

NO >> GO TO 2.

2. CHECK HARNESS CONTINUITY (OPEN CIRCUIT)

1. Disconnect IPDM E/R connector.
2. Check continuity between starter motor harness connector and the IPDM E/R harness connector.

Starter motor harness connector		IPDM E/R harness connector		Continuity
Connector	Terminal	Connector	Terminal	
F28	S	F17	51	Yes

3. Check continuity between starter motor terminal S and ground.

Connector	Terminal	—	Continuity
F28	S	Ground	No

Is the inspection result normal?

YES >> Further inspection is necessary. Refer to [STR-10, "Work Flow \(With GR8-1200 NI\)"](#) or [STR-14, "Work Flow \(Without GR8-1200 NI\)"](#).

NO >> Repair or replace the harness or connectors.

STARTING SYSTEM

< SYMPTOM DIAGNOSIS >

SYMPTOM DIAGNOSIS

STARTING SYSTEM

Symptom Table

INFOID:000000011153309

A

STR

Symptom	Reference
No normal cranking	Refer to STR-10, "Work Flow (With GR8-1200 NI)" or STR-14, "Work Flow (Without GR8-1200 NI)" .
Starter motor does not rotate	

C

D

E

F

G

H

I

J

K

L

M

N

O

P

STARTER MOTOR

< REMOVAL AND INSTALLATION >

REMOVAL AND INSTALLATION

STARTER MOTOR

Exploded View

INFOID:000000011153310

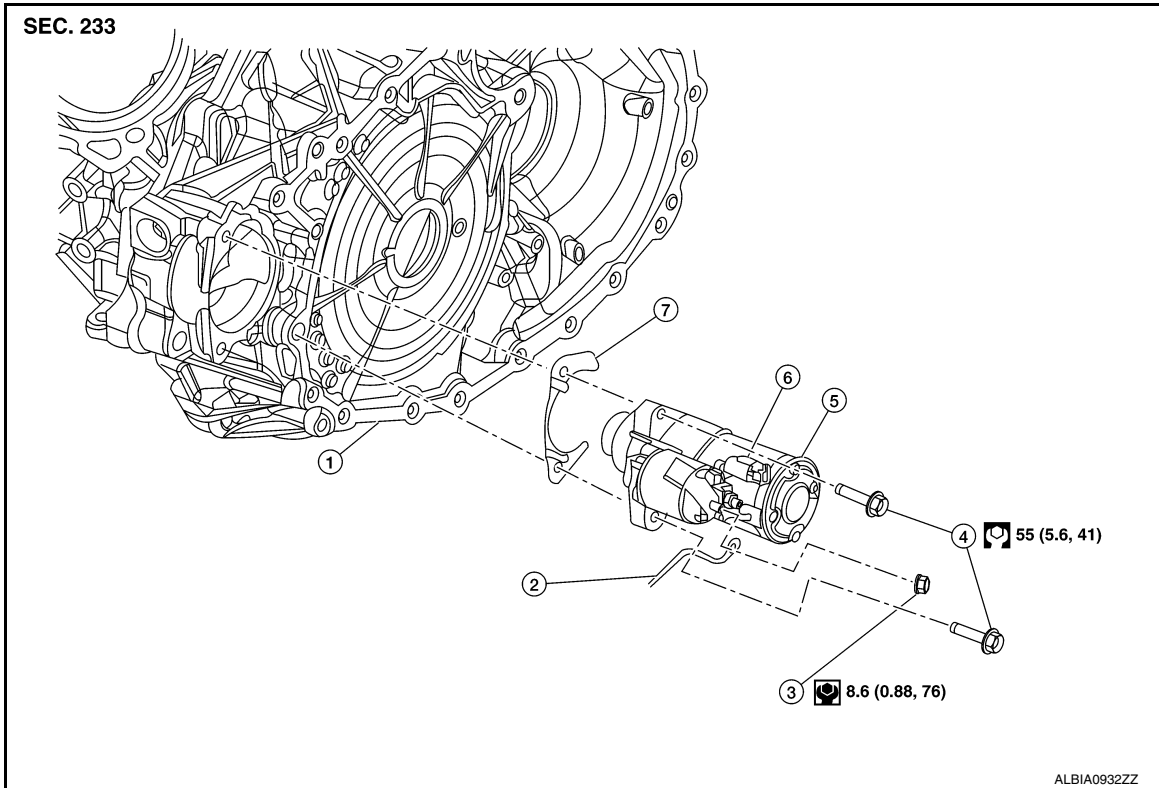

- | | | |
|-----------------------|-------------------------|---------------------|
| 1. Converter housing | 2. "B" terminal harness | 3. "B" terminal nut |
| 4. Starter motor bolt | 5. Starter motor | 6. "S" connector |
| 7. Shim | | |

Removal and Installation

INFOID:000000011153311

NOTE:

When removing components such as hoses, tubes/ lines, etc., cap or plug openings to prevent fluid from spilling.

REMOVAL

1. Remove the air cleaner and air duct. Refer to [EM-24. "Removal and Installation"](#).
2. Remove the battery tray and battery tray support. Refer to [PG-97. "Removal and Installation"](#).
3. Remove CVT water hose A. Refer to [TM-217. "Exploded View"](#).
4. Disconnect the "S" connector, and the "B" terminal harness.
5. Remove the starter motor bolts, then remove the starter motor.

INSTALLATION

Installation is in the reverse order of removal.

STARTER MOTOR

< SERVICE DATA AND SPECIFICATIONS (SDS)

SERVICE DATA AND SPECIFICATIONS (SDS)

STARTER MOTOR

Starter

INFOID:000000011153312

A

STR

Application		VQ35DE	
		For USA and Canada	For Mexico
Type*		Mitsubishi M000TB0271ZC	Mitsubishi M000TA0073ZC
		Reduction gear type	
System voltage		12V	
No-load	Terminal voltage	11V	
	Current	Less than 90A	
	Revolution	More than 2,370 rpm	More than 2,400 rpm

*: Always check with the Parts Department for the latest parts information.

C

D

E

F

G

H

I

J

K

L

M

N

O

P