

SECTION **HA**

**HEATER & AIR CONDITIONING SYSTEM**

**CONTENTS**

<b>PRECAUTION</b> .....	<b>3</b>	<b>NOISE</b> .....	<b>20</b>
<b>PRECAUTIONS</b> .....	<b>3</b>	Symptom Table .....	20
Precaution for Supplemental Restraint System (SRS) "AIR BAG" and "SEAT BELT PRE-TENSIONER" .....	3	<b>PERIODIC MAINTENANCE</b> .....	<b>21</b>
Precaution for Work .....	3	<b>REFRIGERANT</b> .....	<b>21</b>
Precaution for Procedure without Cowl Top Cover.....	4	Description .....	21
Precautions For Refrigerant System Service .....	4	Leak Test .....	21
Service Equipment .....	7	Recycle Refrigerant .....	23
<b>PREPARATION</b> .....	<b>9</b>	Charge Refrigerant .....	23
<b>PREPARATION</b> .....	<b>9</b>	<b>OIL</b> .....	<b>25</b>
Special Service Tool .....	9	Description .....	25
Commercial Service Tool .....	9	Inspection .....	25
Sealant and/or Oil .....	11	Perform Oil Return Operation .....	25
<b>SYSTEM DESCRIPTION</b> .....	<b>12</b>	Oil Adjusting Procedure for Components Replacement Except Compressor .....	25
<b>COMPONENT PARTS</b> .....	<b>12</b>	Oil Adjusting Procedure for Compressor Replacement .....	26
Component Parts Location .....	12	<b>PERFORMANCE TEST</b> .....	<b>28</b>
Component Description .....	12	Inspection .....	28
<b>SYSTEM</b> .....	<b>13</b>	<b>REMOVAL AND INSTALLATION</b> .....	<b>30</b>
System Diagram .....	13	<b>COMPRESSOR</b> .....	<b>30</b>
System Description .....	13	Exploded View .....	30
<b>BASIC INSPECTION</b> .....	<b>15</b>	<b>COMPRESSOR</b> .....	<b>30</b>
<b>DIAGNOSIS AND REPAIR WORKFLOW</b> .....	<b>15</b>	COMPRESSOR : Removal and Installation .....	30
Workflow .....	15	<b>MAGNET CLUTCH</b> .....	<b>31</b>
<b>SYMPTOM DIAGNOSIS</b> .....	<b>17</b>	MAGNET CLUTCH : Removal and Installation of Compressor Clutch .....	31
<b>HEATER AND AIR CONDITIONING SYSTEM SYMPTOMS</b> .....	<b>17</b>	<b>COOLER PIPE AND HOSE</b> .....	<b>34</b>
Symptom Table .....	17	Exploded View .....	34
<b>REFRIGERATION SYSTEM SYMPTOMS</b> .....	<b>18</b>	<b>HIGH-PRESSURE AND LOW-PRESSURE PIPE</b> ....	<b>34</b>
Trouble Diagnosis For Unusual Pressure .....	18	HIGH-PRESSURE AND LOW-PRESSURE PIPE : Removal and Installation .....	34
Symptom Table .....	18	<b>LOW-PRESSURE FLEXIBLE HOSE</b> .....	<b>35</b>

LOW-PRESSURE FLEXIBLE HOSE : Removal and Installation .....	35	HEATING AND COOLING UNIT ASSEMBLY : Exploded View .....	41
<b>HIGH-PRESSURE PIPE .....</b>	<b>35</b>	HEATING AND COOLING UNIT ASSEMBLY : Removal and Installation .....	42
HIGH-PRESSURE PIPE : Removal and Installation .....	35	HEATING AND COOLING UNIT ASSEMBLY : Exploded View .....	43
<b>HIGH-PRESSURE FLEXIBLE HOSE .....</b>	<b>35</b>	HEATING AND COOLING UNIT ASSEMBLY : Removal and Installation .....	43
HIGH-PRESSURE FLEXIBLE HOSE : Removal and Installation .....	35	<b>HEATER CORE .....</b>	<b>44</b>
<b>UNDERFLOOR REAR HIGH-PRESSURE AND LOW-PRESSURE A/C PIPES .....</b>	<b>36</b>	HEATER CORE : Exploded View .....	44
UNDERFLOOR REAR HIGH-PRESSURE AND LOW-PRESSURE A/C PIPES : Exploded View ....	36	HEATER CORE : Removal and Installation .....	44
UNDERFLOOR REAR HIGH-PRESSURE AND LOW-PRESSURE A/C PIPES : Removal and Installation .....	36	<b>EVAPORATOR .....</b>	<b>44</b>
<b>CONDENSER .....</b>	<b>38</b>	EVAPORATOR : Exploded View .....	45
Exploded View .....	38	EVAPORATOR : Removal and Installation .....	45
<b>CONDENSER .....</b>	<b>38</b>	EVAPORATOR : Exploded View .....	46
CONDENSER : Removal and Installation .....	38	EVAPORATOR : Removal and Installation .....	46
<b>CONDENSER PIPE ASSEMBLY .....</b>	<b>39</b>	<b>EXPANSION VALVE .....</b>	<b>46</b>
CONDENSER PIPE ASSEMBLY : Removal and Installation .....	39	EXPANSION VALVE : Exploded View .....	47
<b>LIQUID TANK .....</b>	<b>39</b>	EXPANSION VALVE : Removal and Installation ...	47
LIQUID TANK : Removal and Installation .....	39	EXPANSION VALVE : Exploded View .....	48
<b>REFRIGERANT PRESSURE SENSOR .....</b>	<b>39</b>	EXPANSION VALVE : Removal and Installation ...	48
REFRIGERANT PRESSURE SENSOR : Removal and Installation .....	39	<b>PTC HEATER .....</b>	<b>49</b>
<b>HEATING AND COOLING UNIT ASSEMBLY...</b>	<b>41</b>	Exploded View .....	49
<b>HEATING AND COOLING UNIT ASSEMBLY .....</b>	<b>41</b>	Removal and Installation .....	49
		<b>SERVICE DATA AND SPECIFICATIONS (SDS) .....</b>	<b>50</b>
		<b>SERVICE DATA AND SPECIFICATIONS (SDS) .....</b>	<b>50</b>
		Compressor .....	50
		Oil .....	50
		Refrigerant .....	50

# PRECAUTIONS

< PRECAUTION >

## PRECAUTION

### PRECAUTIONS

#### Precaution for Supplemental Restraint System (SRS) "AIR BAG" and "SEAT BELT PRE-TENSIONER"

INFOID:000000012551248

The Supplemental Restraint System such as "AIR BAG" and "SEAT BELT PRE-TENSIONER", used along with a front seat belt, helps to reduce the risk or severity of injury to the driver and front passenger for certain types of collision. Information necessary to service the system safely is included in the SR and SB section of this Service Manual.

#### **WARNING:**

- To avoid rendering the SRS inoperative, which could increase the risk of personal injury or death in the event of a collision which would result in air bag inflation, it is recommended that all maintenance and repair be performed by an authorized NISSAN/INFINITI dealer.
- Improper repair, including incorrect removal and installation of the SRS, can lead to personal injury caused by unintentional activation of the system. For removal of Spiral Cable and Air Bag Module, see the SR section.
- Do not use electrical test equipment on any circuit related to the SRS unless instructed to in this Service Manual. SRS wiring harnesses can be identified by yellow and/or orange harnesses or harness connectors.

#### PRECAUTIONS WHEN USING POWER TOOLS (AIR OR ELECTRIC) AND HAMMERS

#### **WARNING:**

- When working near the Air Bag Diagnosis Sensor Unit or other Air Bag System sensors with the Ignition ON or engine running, DO NOT use air or electric power tools or strike near the sensor(s) with a hammer. Heavy vibration could activate the sensor(s) and deploy the air bag(s), possibly causing serious injury.
- When using air or electric power tools or hammers, always switch the Ignition OFF, disconnect the battery or batteries, and wait at least three minutes before performing any service.

#### Precaution for Work

INFOID:000000012551249

- When removing or disassembling each component, be careful not to damage or deform it. If a component may be subject to interference, be sure to protect it with a shop cloth.
- When removing (disengaging) components with a screwdriver or similar tool, be sure to wrap the component with a shop cloth or vinyl tape to protect it.
- Protect the removed parts with a shop cloth and prevent them from being dropped.
- Replace a deformed or damaged clip.
- If a part is specified as a non-reusable part, always replace it with a new one.
- Be sure to tighten bolts and nuts securely to the specified torque.
- After installation is complete, be sure to check that each part works properly.
- Follow the steps below to clean components:
  - Water soluble dirt:
    - Dip a soft cloth into lukewarm water, wring the water out of the cloth and wipe the dirty area.
    - Then rub with a soft, dry cloth.
  - Oily dirt:
    - Dip a soft cloth into lukewarm water with mild detergent (concentration: within 2 to 3%) and wipe the dirty area.
    - Then dip a cloth into fresh water, wring the water out of the cloth and wipe the detergent off.
    - Then rub with a soft, dry cloth.
  - Do not use organic solvent such as thinner, benzene, alcohol or gasoline.
  - For genuine leather seats, use a genuine leather seat cleaner.

# PRECAUTIONS

## < PRECAUTION >

### Precaution for Procedure without Cowl Top Cover

INFOID:000000012551250

When performing the procedure after removing cowl top cover, cover the lower end of windshield with urethane, etc to prevent damage to windshield.

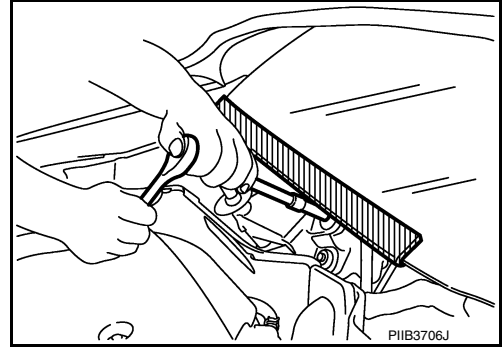

### Precautions For Refrigerant System Service

INFOID:000000012551251

#### WORKING WITH HFC-134a (R-134a)

##### **CAUTION:**

- CFC-12 (R-12) refrigerant and HFC-134a (R-134a) refrigerant are not compatible. Compressor malfunction is likely to occur if the refrigerants are mixed, refer to “CONTAMINATED REFRIGERANT” below. To determine the purity of HFC-134a (R-134a) in the vehicle and recovery tank, use Refrigerant recovery/recycling recharging equipment and Refrigerant Identifier.
- Use only specified oil for the HFC-134a (R-134a) A/C system and HFC-134a (R-134a) components. Compressor malfunction is likely to occur if oil other than that specified is used.
- The specified HFC-134a (R-134a) oil rapidly absorbs moisture from the atmosphere. The following handling precautions must be observed:
  - Cap (seal) the component immediately to minimize the entry of moisture from the atmosphere when removing refrigerant components from a vehicle.
  - Do not remove the caps (unseal) until just before connecting the components when installing refrigerant components to a vehicle. Connect all refrigerant loop components as quickly as possible to minimize the entry of moisture into system.
  - Use only the specified oil from a sealed container. Reseal containers of oil immediately. Oil becomes moisture saturated and should not be used without proper sealing.
  - Do not allow oil to come in contact with styrene foam parts. Damage may result.

#### GENERAL REFRIGERANT PRECAUTION

##### **WARNING:**

- Do not breathe A/C refrigerant and oil vapor or mist. Exposure may irritate eyes, nose and throat. Remove HFC-134a (R-134a) from the A/C system, using certified service equipment meeting requirements of SAE J-2210 [HFC-134a (R-134a) recycling equipment] or J-2209 [HFC-134a (R-134a) recovery equipment]. Ventilate work area before resuming service if accidental system discharge occurs. Additional health and safety information may be obtained from refrigerant and oil manufacturers.
- Do not release refrigerant into the air. Use approved recovery/recycling recharging equipment to capture the refrigerant each time an air conditioning system is discharged.
- Always wear eye and hand protection (goggles and gloves) when working with any refrigerant or air conditioning system.
- Do not store or heat refrigerant containers above 52°C (126°F).
- Do not heat a refrigerant container with an open flame; Place the bottom of the container in a warm pail of water if container warming is required.
- Do not intentionally drop, puncture or incinerate refrigerant containers.
- Keep refrigerant away from open flames; poisonous gas is produced if refrigerant burns.
- Refrigerant displaces oxygen; therefore be certain to work in well ventilated areas to prevent suffocation.
- Do not pressure test or leakage test HFC-134a (R-134a) service equipment and/or vehicle air conditioning systems with compressed air during repair. Some mixtures of air and HFC-134a (R-134a) have been shown to be combustible at elevated pressures. These mixtures, if ignited, may cause injury or property damage. Additional health and safety information may be obtained from refrigerant manufacturers.

#### O-RING AND REFRIGERANT CONNECTION

# PRECAUTIONS

< PRECAUTION >

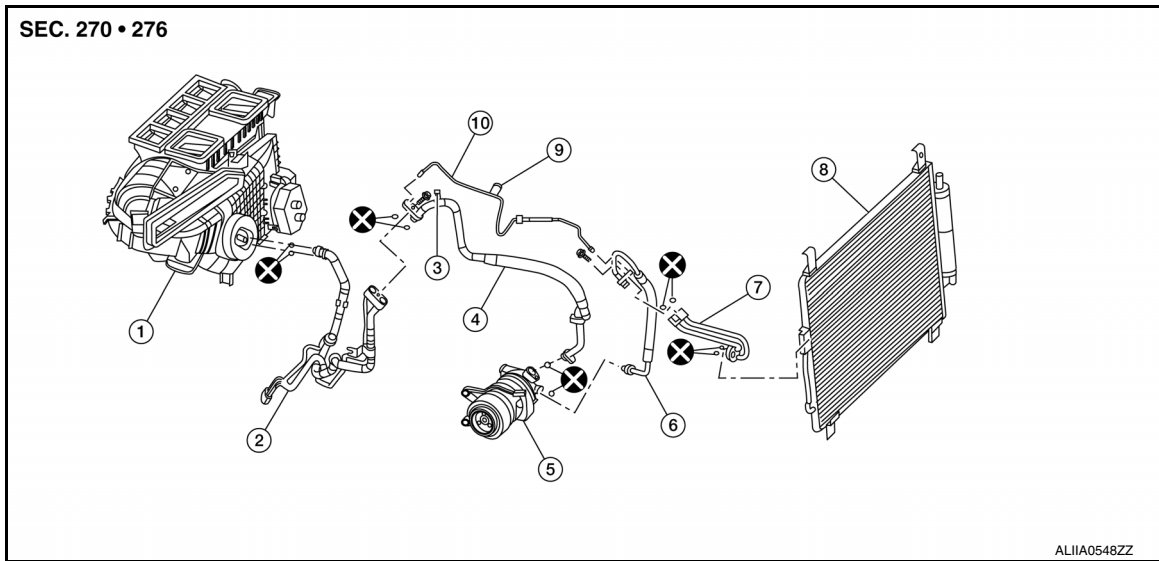

- |  |  |                                |
|--|--|--------------------------------|
| 1. Front heating and cooling unit assembly | 2. High-pressure and low-pressure pipe | 3. Low-pressure service port   |
| 4. Low-pressure flexible hose              | 5. Compressor                          | 6. High-pressure flexible hose |
| 7. Condenser pipe assembly                 | 8. Condenser (includes liquid tank)    | 9. High-pressure service port  |
| 10. High-pressure pipe                     |  |                                |

A new type of refrigerant connection has been introduced to all refrigerant lines except the following locations:

- Expansion valve to evaporator
- Refrigerant pressure sensor to liquid tank

## **WARNING:**

Check that all refrigerant is discharged into the recycling equipment and the pressure in the system is less than atmospheric pressure. Then gradually loosen the discharge side hose fitting and remove it.

## **CAUTION:**

Observe the following when replacing or cleaning refrigerant components.

- Store it in the same way as it is when mounted on the vehicle when the compressor is removed. Failure to do so will cause oil to enter the low-pressure chamber.
- Always use a torque wrench and a back-up wrench when connecting tubes.
- Immediately plug all openings to prevent entry of dust and moisture after disconnecting tubes.
- Connect the pipes at the final stage of the operation when installing an air conditioner in the vehicle. Do not remove the seal caps of pipes and other components until just before required for connection.
- Allow components stored in cool areas to warm to working area temperature before removing seal caps. This prevents condensation from forming inside A/C components.
- Remove moisture thoroughly from the refrigeration system before charging the refrigerant.
- Always replace used O-rings.
- Apply oil to the O-rings shown in illustrations when connecting tubes. Be careful not to apply oil to threaded portion.
- O-ring must be closely attached to the groove portion of tube.
- Be careful not to damage O-ring and tube when replacing the O-ring.
- Connect tube until a click can be heard. Then tighten the nut or bolt by hand. Check that the O-ring is installed to tube correctly.

## PRECAUTIONS

### < PRECAUTION >

- Perform leakage test and make sure that there is no leakage from connections after connecting line. Disconnect that line and replace the O-ring when the refrigerant leaking point is found. Then tighten connections of seal seat to the specified torque.

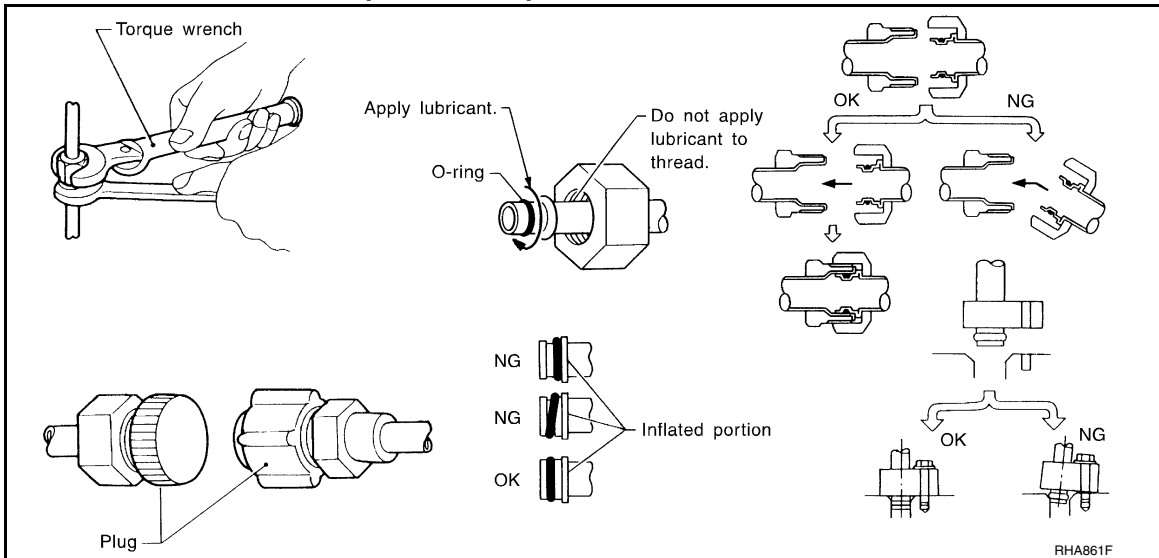

### CONTAMINATED REFRIGERANT

Take appropriate steps shown below if a refrigerant other than pure HFC-134a (R-134a) is identified in a vehicle:

- Explain to the customer that environmental regulations prohibit the release of contaminated refrigerant into the atmosphere.
- Explain that recovery of the contaminated refrigerant could damage service equipment and refrigerant supply.
- Suggest the customer return the vehicle to the location of previous service where the contamination may have occurred.
- In case of repairing, recover the refrigerant using only **dedicated equipment and containers**. **Do not recover contaminated refrigerant into the existing service equipment**. Contact a local refrigerant product retailer for available service if the facility does not have dedicated recovery equipment. This refrigerant must be disposed of in accordance with all federal and local regulations. In addition, replacement of all refrigerant system components on the vehicle is recommended.
- The air conditioner warranty is void if the vehicle is within the warranty period. Please contact Nissan Customer Affairs for further assistance.

### COMPRESSOR

#### CAUTION:

- Plug all openings to prevent moisture and foreign matter from entering.
- Store it in the same way as it is when mounted on the car when the compressor is removed.
- Follow "Maintenance of Oil Quantity in Compressor" exactly when replacing or repairing compressor. Refer to [HA-25, "Description"](#).
- Keep friction surfaces between clutch and pulley clean. Wipe it off by using a clean waste cloth moistened with solvent if the surface is contaminated with oil.
- Turn the compressor shaft by hand more than five turns in both directions after compressor service operation. This distributes oil equally inside the compressor. Let the engine idle and operate the compressor for one hour after the compressor is installed.
- Apply voltage to the new one and check for normal operation after replacing the compressor magnet clutch.

### LEAK DETECTION DYE

#### CAUTION:

- The A/C system contains a fluorescent leak detection dye used for locating refrigerant leakages. An ultraviolet (UV) lamp is required to illuminate the dye when inspecting for leakages.
- Always wear fluorescence enhancing UV safety goggles to protect eyes and enhance the visibility of the fluorescent dye.
- The fluorescent dye leak detector is not a replacement for an electronic leak detector (SST: J-41995). The fluorescent dye leak detector should be used in conjunction with an electronic leak detector (SST: J-41995) to pin-point refrigerant leakages.

# PRECAUTIONS

## < PRECAUTION >

- Read and follow all manufacturer's operating instructions and precautions prior to performing the work for the purpose of safety and customer's satisfaction.
- A compressor shaft seal should not necessarily be repaired because of dye seepage. The compressor shaft seal should only be repaired after confirming the leakage with an electronic leak detector (SST: J-41995).
- Always remove any remaining dye from the leakage area after repairs are completed to avoid a misdiagnosis during a future service.
- Do not allow dye to come into contact with painted body panels or interior components. Clean immediately with the approved dye cleaner if dye is spilled. Fluorescent dye left on a surface for an extended period of time cannot be removed.
- Do not spray the fluorescent dye cleaning agent on hot surfaces (engine exhaust manifold, etc.).
- Do not use more than one refrigerant dye bottle [1/4 ounce (7.4 cc)] per A/C system.
- Leak detection dyes for HFC-134a (R-134a) and CFC-12 (R-12) A/C systems are different. Do not use HFC-134a (R-134a) leak detection dye in CFC-12 (R-12) A/C system or CFC-12 (R-12) leak detection dye in HFC-134a (R-134a) A/C system or A/C system damage may result.
- The fluorescent properties of the dye remains for three or more years unless a compressor malfunction occurs.

### NOTE:

#### Identification

- Vehicles with factory installed fluorescent dye have a green label.
- Vehicles without factory installed fluorescent dye have a blue label.

## Service Equipment

INFOID:000000012551252

## RECOVERY/RECYCLING RECHARGING EQUIPMENT

Be certain to follow the manufacturer's instructions for machine operation and machine maintenance. Do not introduce any refrigerant other than that specified into the machine.

## ELECTRONIC LEAK DETECTOR

Be certain to follow the manufacturer's instructions for detector operation and maintenance.

## VACUUM PUMP

The oil contained inside the vacuum pump is not compatible with the specified oil for HFC-134a (R-134a) A/C systems. The vent side of the vacuum pump is exposed to atmospheric pressure, so the vacuum pump oil may migrate out of the pump into the service hose. This is possible when the pump is switched OFF after evacuation (vacuuming) and hose is connected to it.

To prevent this migration, use a manual valve placed near the hose-to-pump connection, as per the following.

- Vacuum pumps usually have a manual isolator valve as part of the pump. Close this valve to isolate the service hose from the pump.
- Use a hose equipped with a manual shut-off valve near the pump end for pumps without an isolator. Close the valve to isolate the hose from the pump.
- Disconnect the hose from the pump if the hose has an automatic shut-off valve. As long as the hose is connected, the valve is open and oil may migrate.

Some one-way valves open when vacuum is applied and close under no vacuum condition. Such valves may restrict the pump's ability to pull a deep vacuum and are not recommended.

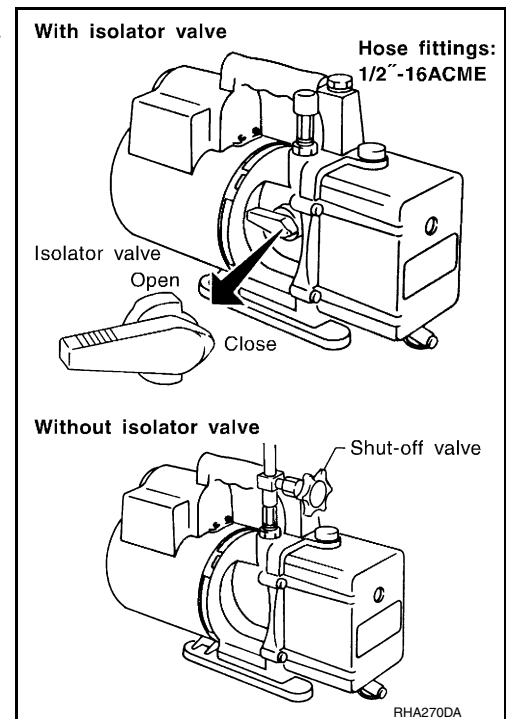

## MANIFOLD GAUGE SET

# PRECAUTIONS

## < PRECAUTION >

Be certain that the gauge face indicates HFC-134a or R-134a. Be sure the gauge set has 1/2"-16 ACME threaded connections for service hoses. Confirm the set has been used only with refrigerant HFC-134a (R-134a) and specified oils.

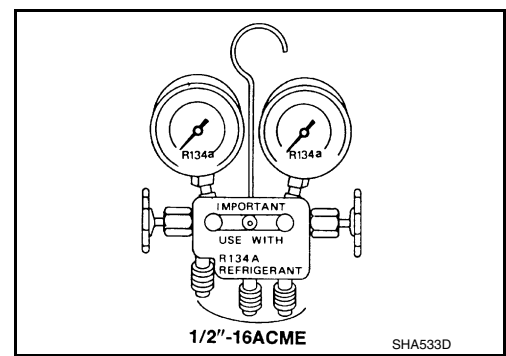

## SERVICE HOSES

Be certain that the service hoses display the markings described (colored hose with black stripe). All hoses must include positive shut-off devices (either manual or automatic) near the end of the hoses opposite to the manifold gauge.

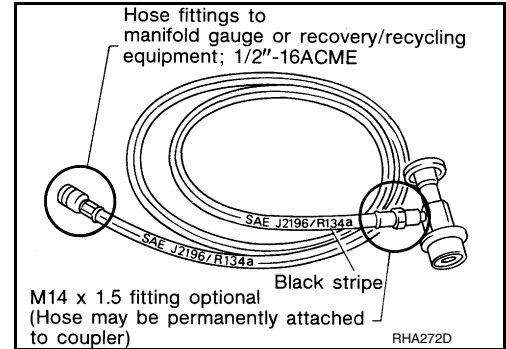

## SERVICE COUPLERS

Do not attempt to connect HFC-134a (R-134a) service couplers to the CFC-12 (R-12) A/C system. The HFC-134a (R-134a) couplers do not properly connect to the CFC-12 (R-12) system. However, if an improper connection is attempted, discharging and contamination may occur.

Shut-off valve rotation	A/C service valve
Clockwise	Open
Counterclockwise	Close

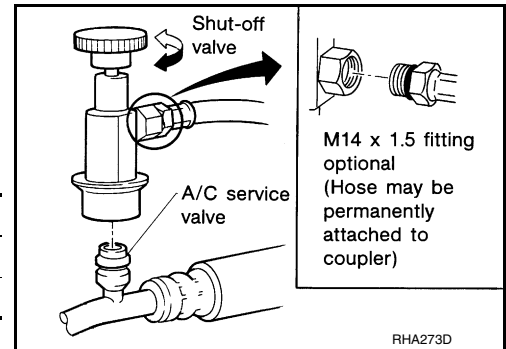

## REFRIGERANT WEIGHT SCALE

Verify that no refrigerant other than HFC-134a (R-134a) and specified oils have been used with the scale. The hose fitting must be 1/2"-16 ACME if the scale controls refrigerant flow electronically.

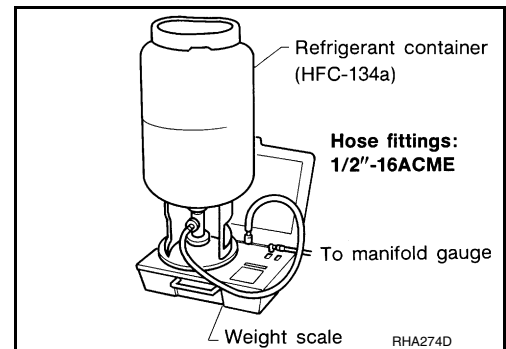

## CHARGING CYLINDER

Using a charging cylinder is not recommended. Refrigerant may be vented into air from cylinder's top valve when filling the cylinder with refrigerant. Also, the accuracy of the cylinder is generally less than that of an electronic scale or of quality recycle/recharge equipment.



# PREPARATION

< PREPARATION >

## PREPARATION

### PREPARATION

#### Special Service Tool

INFOID:000000012551253

The actual shape of the tools may differ from those illustrated here.

Tool number (TechMate No.) Tool name	Description
— (J-41425-NIS) Aluminum tube repair kit	Repairing leaks in A/C tubes
— (J-38873-A) Drive plate installer	Installing pulley
— (J-46534) Trim Tool Set	Removing trim components

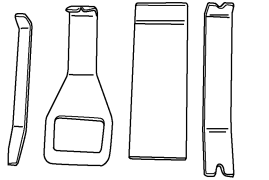
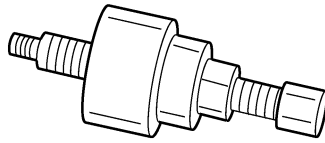
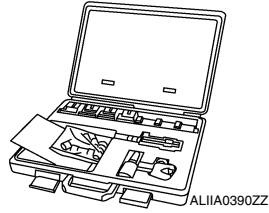

#### Commercial Service Tool

INFOID:000000012551254

(TechMate No.) Tool name	Description
(J-41810-NI) Refrigerant identifier equipment (R-134a)	For checking refrigerant purity and system contamination
( — ) Power tool	Loosening nuts, screws and bolts

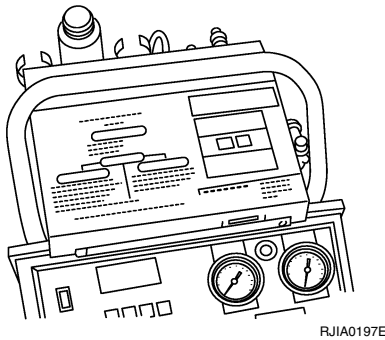

A  
B  
C  
D  
E  
F  
G  
H  
HA  
J  
K  
L  
M  
N  
O  
P

# PREPARATION

## < PREPARATION >

(TechMate No.) Tool name	Description
(J-48710) NISSAN ACR2009 RRR Unit	Refrigerant recovery, recycling and re-charging
(J-41995) Electronic refrigerant leak detector	Power supply: • DC 12V (battery terminal)
(J-43926) Refrigerant dye leak detection kit Kit includes: (J-42220) UV lamp and UV safety goggles (J-41459) Refrigerant dye injector (J-41447) Fluorescent leak detection dye (box of 24, 1/4 ounce bottles) (J-43872) Refrigerant dye cleaner	Power supply: • DC 12V (battery terminal)
(J-39183-C) Manifold gauge set (with hoses and couplers)	Identification: • The gauge face indicates R-134a. Fitting size-Thread size • 1/2"-16 ACME
Service hoses: • High side hose (J-39500-72B) • Low side hose (J-39500-72R) • Utility hose (J-39500-72Y)	Hose color: • Low side hose: Blue with black stripe • High side hose: Red with black stripe • Utility hose: Yellow with black stripe or green with black stripe Hose fitting to gauge: • 1/2"-16 ACME

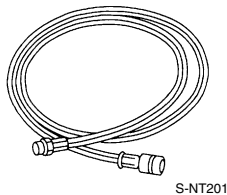
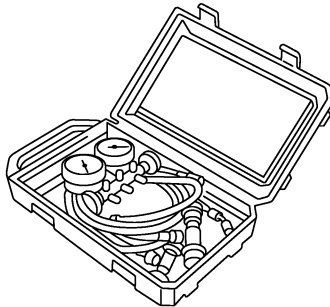
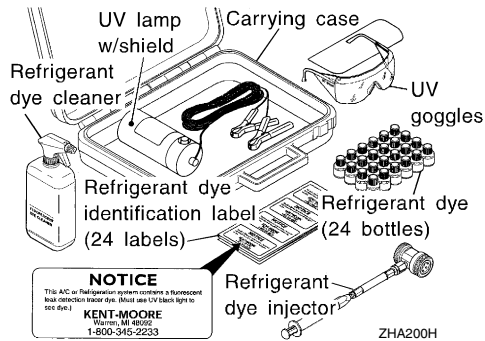
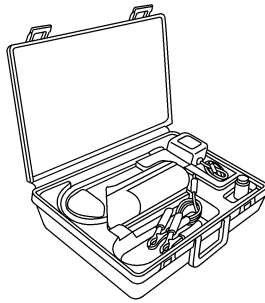
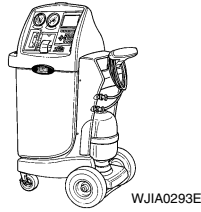

# PREPARATION

## < PREPARATION >

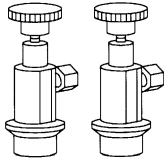
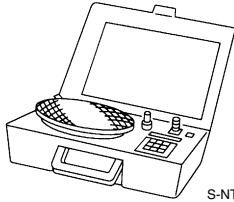
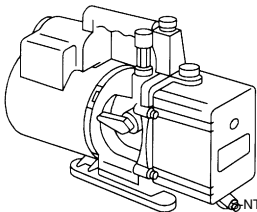
(TechMate No.) Tool name	Description	A
Service couplers <ul style="list-style-type: none"> <li>• High side coupler (J-39500-20A)</li> <li>• Low side coupler (J-39500-24A)</li> </ul>  <p style="text-align: center;">S-NT202</p>	Hose fitting to service hose: <ul style="list-style-type: none"> <li>• M14 x 1.5 fitting is optional or permanently attached.</li> </ul>	B C
(J-39699) Refrigerant weight scale  <p style="text-align: center;">S-NT200</p>	For measuring of refrigerant Fitting size-Thread size <ul style="list-style-type: none"> <li>• 1/2"-16 ACME</li> </ul>	D E
(J-39649) Vacuum pump (Including the isolator valve)  <p style="text-align: center;">S-NT203</p>	Capacity: <ul style="list-style-type: none"> <li>• Air displacement: 4 CFM</li> <li>• Micron rating: 20 microns</li> <li>• Oil capacity: 482 g (17 oz)</li> </ul> Fitting size-Thread size <ul style="list-style-type: none"> <li>• 1/2"-16 ACME</li> </ul>	F G H

## Sealant and/or Oil

INFOID:0000000012551255

HA

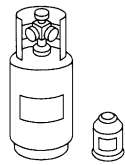
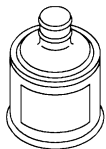
Tool number (TechMate No.) Tool name	Description	J
— ( — ) HFC-134a (R-134a) Refrigerant  <p style="text-align: center;">S-NT196</p>	Container color: Light blue Container marking: HFC-134a (R-134a) Fitting size: Thread size <ul style="list-style-type: none"> <li>• large container 1/2"-16 ACME</li> </ul>	K L
— ( — ) NISSAN A/C System Oil Type S  <p style="text-align: center;">JMIIA1759ZZ</p>	Type: Poly alkylene glycol oil (PAG), type S (DH-PS) Application: HFC-134a (R-134a) swash plate compressors Capacity: 40 m ℓ (1.4 US fl oz, 1.4 Imp fl oz)	M N O

P

# COMPONENT PARTS

< SYSTEM DESCRIPTION >

## SYSTEM DESCRIPTION

### COMPONENT PARTS

#### Component Parts Location

INFOID:0000000012551256

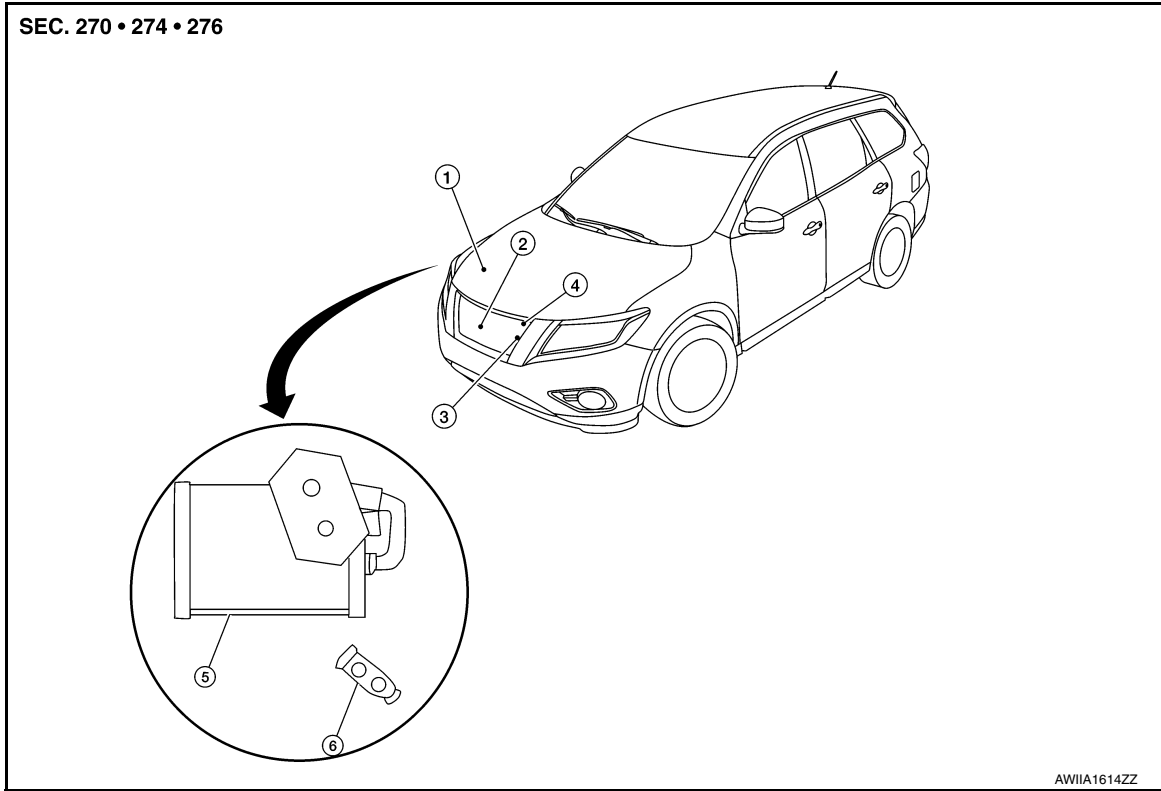

- |                                |               |                    |
|--------------------------------|---------------|--------------------|
| 1. Compressor                  | 2. Condenser  | 3. Liquid tank     |
| 4. Refrigerant pressure sensor | 5. Evaporator | 6. Expansion valve |

#### Component Description

INFOID:0000000012551257

Component	Description
Compressor	Intakes, compresses and discharges refrigerant to circulate refrigerant inside the refrigerant system.
Condenser	Cools refrigerant discharged from compressor and transforms it to liquid refrigerant.
Liquid tank	Eliminates foreign matter in refrigerant and stores temporarily liquid refrigerant.
Refrigerant pressure sensor	Refer to <a href="#">EC-490. "Component Function Check"</a> (USA and Canada) or <a href="#">EC-867. "Component Function Check"</a> (Mexico).
Expansion valve	Transforms high-pressure liquid refrigerant to mist form low-pressure liquid refrigerant.
Evaporator	The mist form liquid refrigerant transforms to gas by evaporation by the air conveyed from blower motor. The air is cooled by the heat by evaporation.

# SYSTEM

< SYSTEM DESCRIPTION >

## SYSTEM

### System Diagram

INFOID:000000012551258

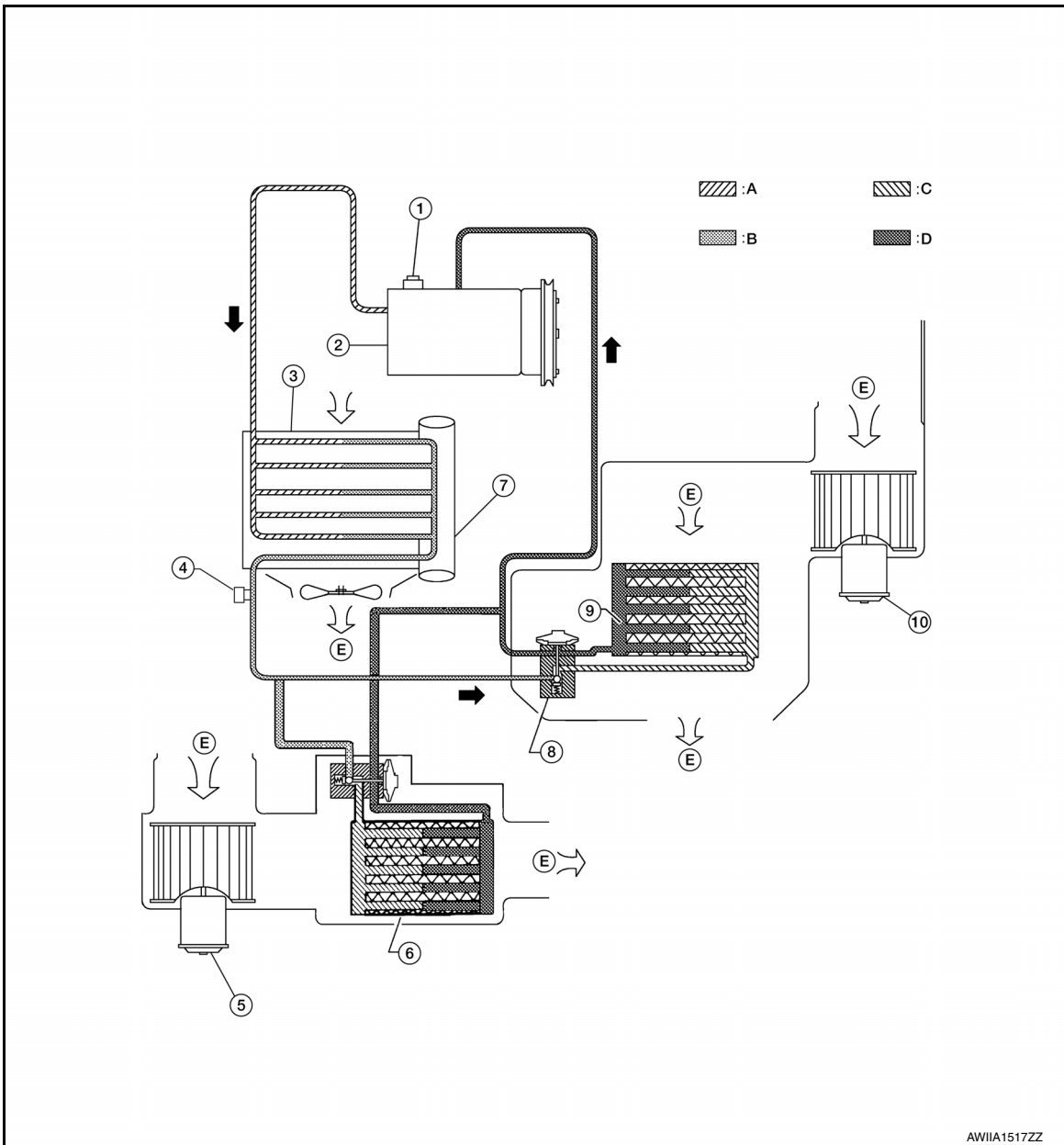

- |                                |                         |  |
|--------------------------------|-------------------------|--|
| 1. Pressure relief valve       | 2. Compressor           | 3. Condenser                                     |
| 4. Refrigerant pressure sensor | 5. Front blower motor   | 6. Front evaporator and expansion valve assembly |
| 7. Liquid tank                 | 8. Rear expansion valve | 9. Rear evaporator                               |
| 10. Rear blower motor          | A. High-pressure gas    | B. High-pressure liquid                          |
| C. Low-pressure liquid         | D. Low-pressure gas     | E. Outside air                                   |

### System Description

INFOID:000000012551259

#### REFRIGERANT CYCLE

##### Refrigerant Flow

The refrigerant from the compressor flows through the condenser and liquid tank, evaporator, and returns to the compressor. The refrigerant evaporation in the evaporator is controlled by an expansion valve.

A  
B  
C  
D  
E  
F  
G  
H  
HA  
J  
K  
L  
M  
N  
O  
P

# SYSTEM

## < SYSTEM DESCRIPTION >

---

### Freeze Protection

To prevent evaporator from freezing up, the evaporator air temperature is monitored and the voltage signal to the A/C auto amp. makes the A/C relay go OFF and stop the compressor.

### REFRIGERANT SYSTEM PROTECTION

#### Refrigerant Pressure Sensor

- The refrigerant system is protected against excessively high or low pressures by the refrigerant pressure sensor, located on the liquid tank. The refrigerant pressure sensor detects the pressure inside the refrigerant line and sends the voltage signal to the ECM if the system pressure rises above or falls below the specifications.
- ECM turns the A/C relay to OFF and stops the compressor when the high-pressure side detected by refrigerant pressure sensor to have the following conditions:
  - Approximately 3,120 kPa (31.8 kg/cm<sup>2</sup>, 452 psi) or more (Engine speed is 1,500 rpm or more.)
  - Approximately 2,740 kPa (27.9 kg/cm<sup>2</sup>, 397 psi) or more (Engine speed is less than 1,500 rpm.)
  - Approximately 120 kPa (1.2 kg/cm<sup>2</sup>, 17 psi) or less

#### Pressure Relief Valve

The refrigerant system is also protected by a pressure relief valve, located in the rear head of the compressor. The release port on the pressure relief valve automatically opens and releases refrigerant into the atmosphere when the pressure of refrigerant in the system increases to an unusual level [more than 3,800 kPa (38.8 kg/cm<sup>2</sup>, 551 psi)].

# DIAGNOSIS AND REPAIR WORKFLOW

< BASIC INSPECTION >

## BASIC INSPECTION

### DIAGNOSIS AND REPAIR WORKFLOW

Workflow

INFOID:0000000012551260

#### OVERALL SEQUENCE

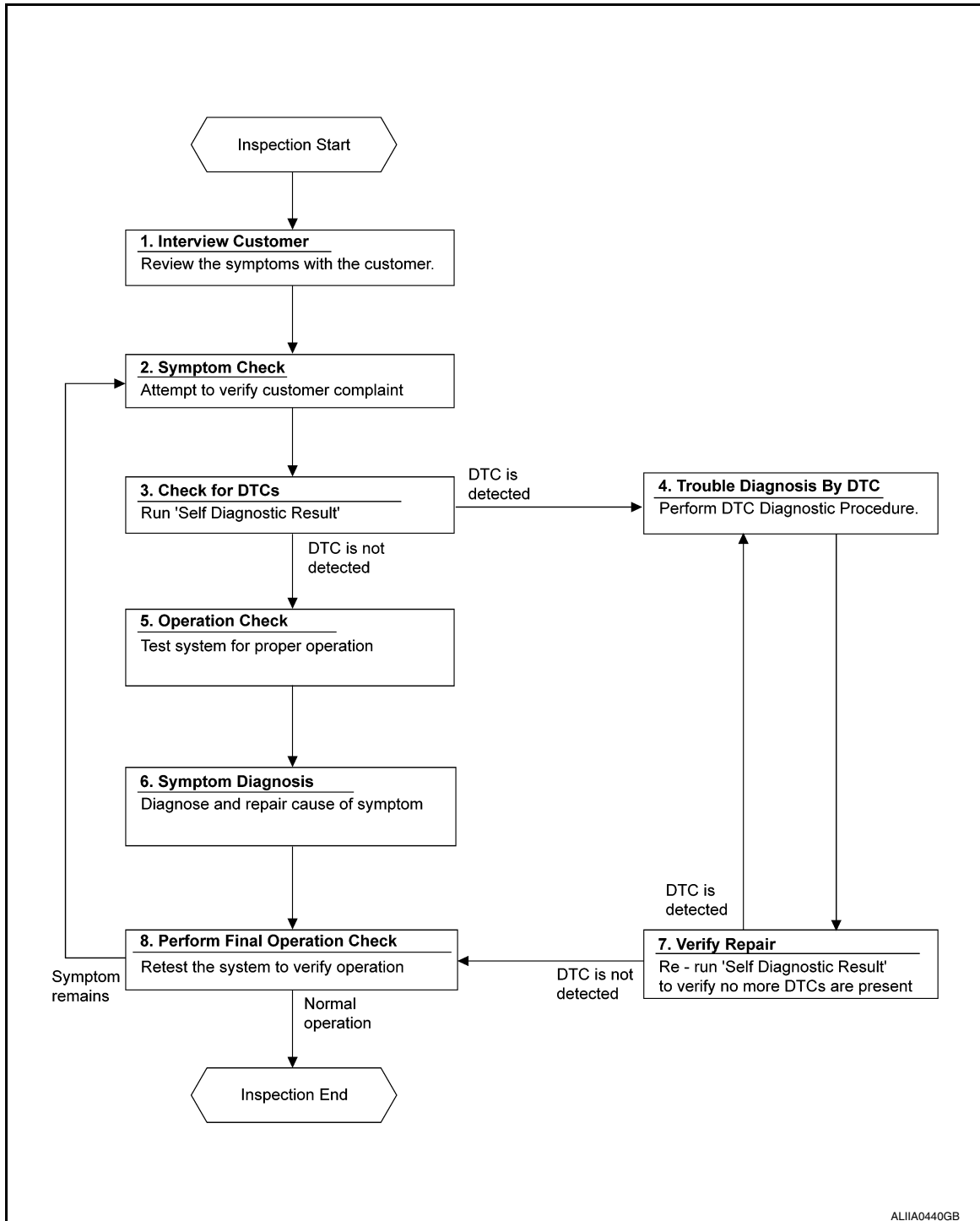

#### DETAILED FLOW

##### 1. INTERVIEW CUSTOMER

Interview the customer to obtain as much information as possible about the conditions and environment under which the malfunction occurred.

# DIAGNOSIS AND REPAIR WORKFLOW

< BASIC INSPECTION >

---

>> GO TO 2.

## 2. SYMPTOM CHECK

---

Verify symptoms.

>> GO TO 3.

## 3. CHECK FOR DTCS

---

④ With CONSULT

1. Turn ignition switch ON.
2. Select "Self Diagnostic Result" mode of "HVAC" using CONSULT.
3. Check DTC.

Is any DTC detected?

YES >> GO TO 4.

NO >> GO TO 5.

## 4. PERFORM DTC DIAGNOSTIC PROCEDURE

---

Perform the diagnostic procedure for the detected DTC. Refer to [HAC-46. "DTC Index"](#).

>> GO TO 7.

## 5. OPERATION CHECK

---

Perform the operation check. Refer to [HAC-74. "FRONT AUTOMATIC AIR CONDITIONING SYSTEM : Work Procedure"](#) (front automatic air conditioning system) or [HAC-75. "REAR AUTOMATIC AIR CONDITIONING SYSTEM : Work Procedure"](#) (rear automatic air conditioning system).

>> GO TO 6.

## 6. SYMPTOM DIAGNOSIS

---

Check the symptom diagnosis table. Refer to [HA-17. "Symptom Table"](#).

>> GO TO 8.

## 7. VERIFY REPAIR.

---

④ With CONSULT

1. Turn ignition switch ON.
2. Select "Self Diagnostic Result" mode of "HVAC" using CONSULT.
3. Check DTC.

Is any DTC detected?

YES >> GO TO 4.

NO >> GO TO 8.

## 8. PERFORM FINAL OPERATION CHECK

---

Perform the operation check. Refer to [HAC-74. "FRONT AUTOMATIC AIR CONDITIONING SYSTEM : Work Procedure"](#) (front automatic air conditioning system) or [HAC-75. "REAR AUTOMATIC AIR CONDITIONING SYSTEM : Work Procedure"](#) (rear automatic air conditioning system).

Does it operate normally?

YES >> Inspection End.

NO >> GO TO 2.



# HEATER AND AIR CONDITIONING SYSTEM SYMPTOMS

< SYMPTOM DIAGNOSIS >

## SYMPTOM DIAGNOSIS

### HEATER AND AIR CONDITIONING SYSTEM SYMPTOMS

#### Symptom Table

INFOID:0000000012551261

#### SYMPTOM TABLE

Symptom	Reference Page	
A/C system does not come on.	Go to Trouble Diagnosis Procedure for A/C System.	<a href="#">HAC-151</a>
A/C system cannot be controlled.	Go to Self-diagnosis Function.	<a href="#">HAC-71</a>
Front air outlet does not change.	Go to Trouble Diagnosis Procedure for Front Mode Door Motor.	<a href="#">HAC-99</a>
Front mode door motor is malfunctioning.		
Rear air outlet does not change.	Go to Trouble Diagnosis Procedure for Rear Mode Door Motor.	<a href="#">HAC-105</a>
Rear mode door motor is malfunctioning.		
Front discharge air temperature does not change (driver side).	Go to Trouble Diagnosis Procedure for Front Air Mix Door Motor (driver side).	<a href="#">HAC-95</a>
Front air mix door motor is malfunctioning (driver side).		
Front discharge air temperature does not change (passenger side).	Go to Trouble Diagnosis Procedure for Front Air Mix Door Motor (passenger side).	<a href="#">HAC-97</a>
Front air mix door motor is malfunctioning (passenger side).		
Rear discharge air temperature does not change.	Go to Trouble Diagnosis Procedure for Rear Air Mix Door Motor.	<a href="#">HAC-103</a>
Rear air mix door motor is malfunctioning.		
Intake door does not change.	Go to Trouble Diagnosis Procedure for Intake Door Motor.	<a href="#">HAC-101</a>
Intake door motor is malfunctioning.		
Front blower motor operation is malfunctioning.	Go to Trouble Diagnosis Procedure for Front Blower Motor.	<a href="#">HAC-130</a>
Rear blower motor operation is malfunctioning.	Go to Trouble Diagnosis Procedure for Rear Blower Motor.	<a href="#">HAC-138</a>
Magnet clutch does not engage.	Go to Trouble Diagnosis Procedure for Magnet Clutch.	<a href="#">HAC-133</a>
Insufficient cooling (front).	Go to Trouble Diagnosis Procedure for Insufficient Cooling.	<a href="#">HAC-147</a>
Insufficient cooling (rear).	Go to Trouble Diagnosis Procedure for Insufficient Cooling.	<a href="#">HAC-148</a>
Insufficient heating (front).	Go to Trouble Diagnosis Procedure for Insufficient Heating.	<a href="#">HAC-149</a>
Insufficient heating (rear).	Go to Trouble Diagnosis Procedure for Insufficient Heating.	<a href="#">HAC-150</a>
Noise.	Go to Trouble Diagnosis Procedure for Noise.	<a href="#">HA-20</a>
Both high- and low-pressure sides are too high.	Go to Trouble Diagnosis Procedure for Abnormal Pressure.	<a href="#">HA-18</a>
High-pressure side is too high and low-pressure side is too low.	Go to Trouble Diagnosis Procedure for Abnormal Pressure.	<a href="#">HA-18</a>
High-pressure side is too low and low-pressure side is too high.	Go to Trouble Diagnosis Procedure for Abnormal Pressure.	<a href="#">HA-18</a>
Both high- and low-pressure side sometimes becomes negative.	Go to Trouble Diagnosis Procedure for Abnormal Pressure.	<a href="#">HA-18</a>
Low-pressure side sometimes becomes negative.	Go to Trouble Diagnosis Procedure for Abnormal Pressure.	<a href="#">HA-18</a>
Low-pressure side becomes negative.	Go to Trouble Diagnosis Procedure for Abnormal Pressure.	<a href="#">HA-18</a>

# REFRIGERATION SYSTEM SYMPTOMS

< SYMPTOM DIAGNOSIS >

## REFRIGERATION SYSTEM SYMPTOMS

### Trouble Diagnosis For Unusual Pressure

INFOID:000000012551262

Diagnose using a manifold gauge whenever system's high and/or low side pressure(s) is/are unusual. The marker above the gauge scale in the following tables indicates the standard (usual) pressure range. Refer to [HA-28, "Inspection"](#).

### Symptom Table

INFOID:000000012551263

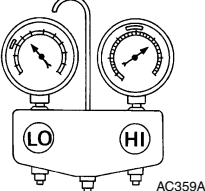
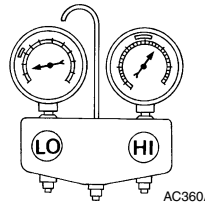
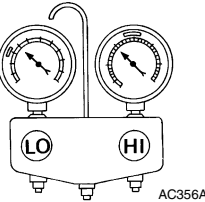
Gauge indication	Refrigerant cycle	Probable cause	Corrective action
<p>Both high and low pressure sides are too high.</p> 	<p>The pressure returns to normal soon after sprinkling water on condenser.</p>	<p>Overfilled refrigerant.</p>	<p>Recover refrigerant, evacuate system, and recharge with the specified amount of refrigerant. Refer to <a href="#">HA-23, "Recycle Refrigerant"</a>.</p>
	<p>Air flow to condenser is insufficient.</p>	<p>Insufficient condenser cooling performance.</p> <ul style="list-style-type: none"> <li>Poor cooling fan rotation.</li> <li>Improper installation of air guides.</li> <li>Clogged or dirty condenser fins.</li> </ul>	<ul style="list-style-type: none"> <li>Repair or replace malfunctioning parts.</li> <li>Clean and repair condenser fins.</li> </ul>
	<p>When compressor is stopped, a high-pressure reading quickly drops by approximately 196 kPa (2 kg/cm<sup>2</sup>, 28 psi). It then gradually decreases.</p>	<p>Air mixed with refrigerant.</p>	<p>Recover refrigerant, evacuate system, and recharge with the specified amount of refrigerant. Refer to <a href="#">HA-23, "Recycle Refrigerant"</a>.</p>
	<ul style="list-style-type: none"> <li>Low-pressure pipe is cooler than the outlet of evaporator.</li> <li>Low-pressure pipe is frosted.</li> </ul>	<p>Expansion valve opened too much (excessive flow of refrigerant).</p>	<p>Replace expansion valve.</p>
<p>High-pressure side is excessively high and low-pressure side is too low.</p> 	<p>High-pressure pipe and upper side of condenser become hot, however, liquid tank does not become so hot.</p>	<p>Clogged or crushed high-pressure pipe located between compressor and condenser.</p>	<p>Repair or replace the malfunctioning parts.</p>
<p>High-pressure side is too low and low-pressure side is too high.</p> 	<ul style="list-style-type: none"> <li>The readings of both sides become equal soon after compressor operation stops.</li> <li>There is no temperature difference between high and low-pressure sides.</li> </ul>	<p>Malfunction in compressor system (insufficient compressor pressure operation).</p> <ul style="list-style-type: none"> <li>Damage or breakage of valve.</li> <li>Malfunctioning gaskets.</li> </ul>	<p>Replace compressor. Refer to <a href="#">HA-30, "COMPRESSOR : Removal and Installation"</a>.</p>

# REFRIGERATION SYSTEM SYMPTOMS

## < SYMPTOM DIAGNOSIS >

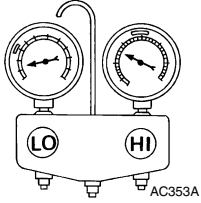
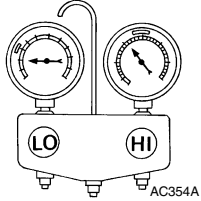
Gauge indication	Refrigerant cycle	Probable cause	Corrective action
<p>Both high and low pressure sides are too low.</p> 	<ul style="list-style-type: none"> <li>The area around evaporator outlet does not become cold.</li> <li>The area around evaporator inlet becomes frosted.</li> </ul>	<ul style="list-style-type: none"> <li>Clogged expansion valve.</li> <li>Breakage of temperature sensor.</li> <li>Clogging by foreign material.</li> </ul>	Eliminate foreign material from expansion valve or replace it.
	<ul style="list-style-type: none"> <li>There is a temperature difference between the areas around outlet and inlet pipes of liquid tank.</li> <li>Liquid tank becomes frosted.</li> </ul>	Malfunction inside liquid tank (clogged strainer).	Replace condenser (includes liquid tank). Refer to <a href="#">HA-38, "CONDENSER : Removal and Installation"</a> .
	Evaporator becomes frosted.	<ul style="list-style-type: none"> <li>Clogged or crushed low-pressure pipe.</li> <li>Malfunction in intake air temperature sensor.</li> </ul>	<ul style="list-style-type: none"> <li>Repair or replace malfunctioning parts.</li> <li>Check intake sensor system. Refer to <a href="#">HAC-90, "Component Inspection"</a>.</li> </ul>
	There is a small temperature difference between the high and low pressure pipes for refrigerant cycle.	<ul style="list-style-type: none"> <li>Low refrigerant charge.</li> <li>Leak or leaks in A/C system.</li> </ul>	<ul style="list-style-type: none"> <li>Check for leaks. Refer to <a href="#">HA-21, "Leak Test"</a>.</li> <li>Recover refrigerant, evacuate system, and recharge with the specified amount of refrigerant. Refer to <a href="#">HA-23, "Recycle Refrigerant"</a>.</li> </ul>
<p>Low-pressure side sometimes becomes negative.</p> 	<ul style="list-style-type: none"> <li>Sometimes the area around evaporator outlet does not become cold.</li> <li>Sometimes the area around evaporator inlet is frosted.</li> </ul>	<ul style="list-style-type: none"> <li>Icing caused by moisture mixed with refrigerant.</li> <li>Deteriorated dryer material in liquid tank.</li> </ul>	<ul style="list-style-type: none"> <li>Recover refrigerant then replace condenser (includes liquid tank). Refer to <a href="#">HA-38, "CONDENSER : Removal and Installation"</a>.</li> <li>Evacuate system and recharge with the specified amount of refrigerant. Refer to <a href="#">HA-23, "Charge Refrigerant"</a>.</li> </ul>
<p>Hunting in high-pressure side.</p>	There is no temperature difference between high and low-pressure sides.	Malfunctioning variable valve in compressor.	<ul style="list-style-type: none"> <li>Replace compressor. Refer to <a href="#">HA-30, "COMPRESSOR : Removal and Installation"</a>.</li> <li>Check ECV system.</li> </ul>

A  
B  
C  
D  
E  
F  
G  
H  
HA  
J  
K  
L  
M  
N  
O  
P

# NOISE

< SYMPTOM DIAGNOSIS >

## NOISE

### Symptom Table

INFOID:000000012551264

Symptom	Noise source	Probable cause	Corrective action
Unusual noise from compressor when A/C is ON.	Inside of compressor	Worn, broken, or clogged internal components.	Check compressor oil. Refer to <a href="#">HA-25, "Inspection"</a> .
	Magnet clutch	Contact of clutch disc with pulley.	Check clearance between clutch disc and pulley.
	Compressor body	Loose compressor bolts.	Check torque of bolts. Refer to <a href="#">HA-30, "Exploded View"</a> .
Unusual noise from cooler piping.	Cooler piping (pipe and flexible hose)	Improper installation of clip and bracket.	Check installation of cooler piping. Refer to <a href="#">HA-34, "Exploded View"</a> .
Unusual noise from expansion valve when A/C is ON.	Expansion valve	Low refrigerant charge.	<ul style="list-style-type: none"> <li>• Check for leaks. Refer to <a href="#">HA-21, "Leak Test"</a>.</li> <li>• Recover refrigerant, evacuate system, and recharge with the specified amount of refrigerant.</li> </ul>
		Worn, broken, or clogged internal components.	Eliminate foreign material from expansion valve or replace it.
Unusual noise from belt.	—	Loose belt.	Check belt tension. Refer to <a href="#">EM-12, "Checking Drive Belt"</a> .
		Damaged or broken components inside compressor.	Replace compressor. Refer to <a href="#">HA-30, "COMPRESSOR : Removal and Installation"</a> .

# REFRIGERANT

< PERIODIC MAINTENANCE >

## PERIODIC MAINTENANCE

### REFRIGERANT

Description

INFOID:0000000012551265

#### CONNECTION OF SERVICE TOOLS AND EQUIPMENT

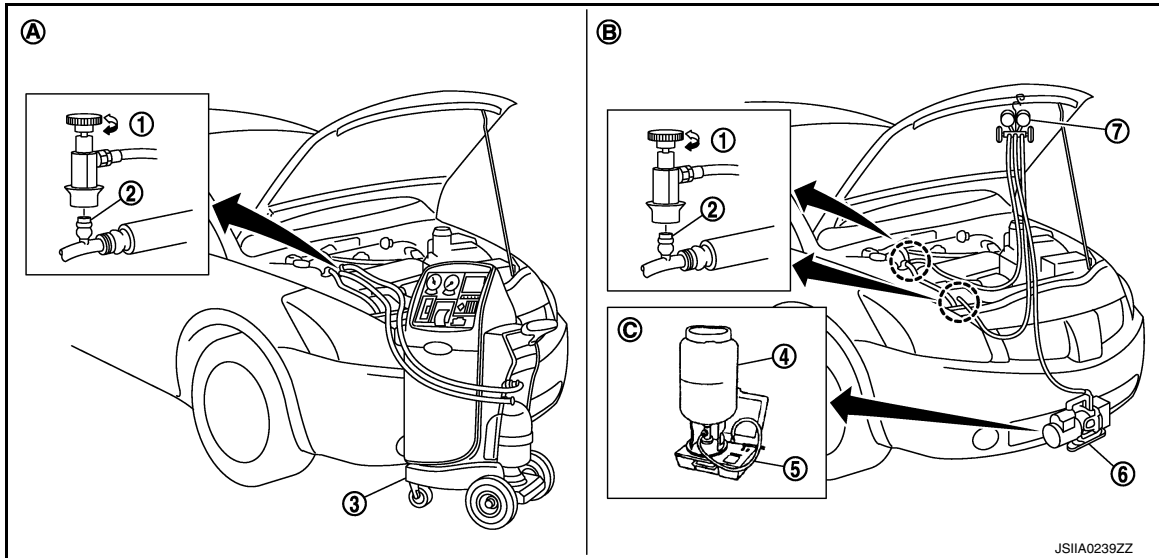

- |                                     |                       |  |
|-------------------------------------|-----------------------|--|
| 1. Shut-off valve                   | 2. A/C service valve  | 3. Recovery/recycling/recharging equipment |
| 4. Refrigerant container (HFC-134a) | 5. Weight scale       | 6. Vacuum pump                             |
| 7. Manifold gauge set               |                       |  |
| A. Preferred (best) method          | B. Alternative method | C. For charging                            |

#### Leak Test

INFOID:0000000012551266

#### CHECK REFRIGERANT LEAKAGE USING FLUORESCENT LEAK DETECTION DYE

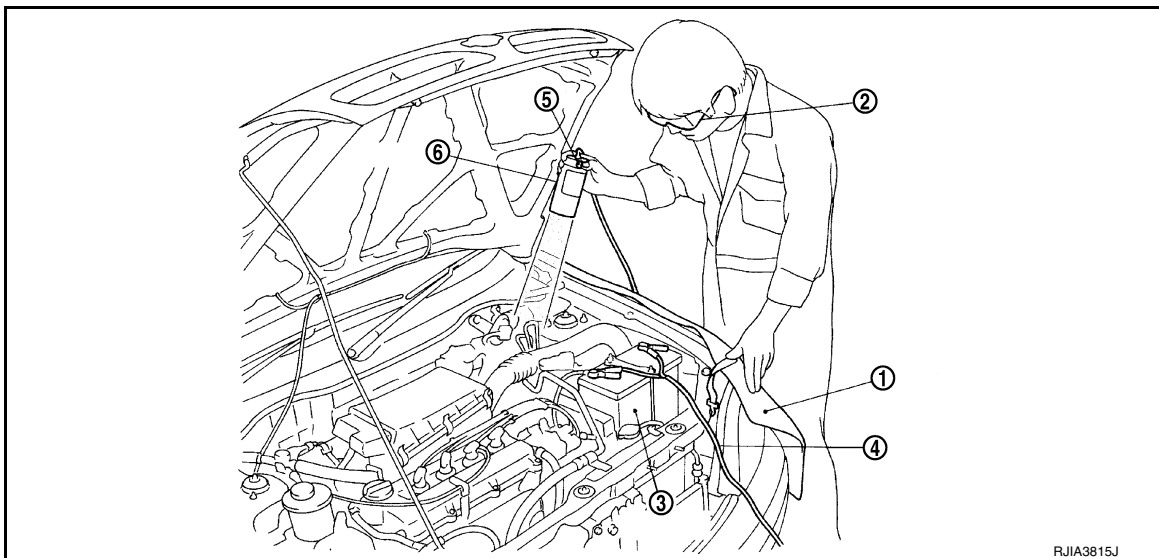

1. Install a fender cover (1).
2. Wear UV safety goggles (2) provided with refrigerant dye leak detection kit.
3. Connect power cable (4) of UV lamp (6) to positive and negative terminals of the battery (3).

# REFRIGERANT

## < PERIODIC MAINTENANCE >

4. Press UV lamp switch (5) and check A/C system for refrigerant leakage. (Where refrigerant leakage occurs, fluorescent leak detection dye appears in green color.)

**WARNING:**

**Do not look directly into UV lamp light source.**

**NOTE:**

- For continuous operating time of UV lamp, follow the manufacturer operating instructions.
- Illuminate piping joints from different angles using UV lamp and check that there is no leakage.
- Use a mirror in area that is difficult to see to check refrigerant leakage.
- Refrigerant leakage from evaporator can be detected by soaking cotton swab or a similar material with drain hose water and illuminating it using UV lamp.
- Dust, dirt, and packing materials adhesive used for condenser, evaporator, and other locations may fluoresce. Be careful not to misidentify leakage.

5. Repair or replace parts where refrigerant leakage occurs and wipe off fluorescent leak detection dye.

**NOTE:**

Completely wipe off fluorescent leak detection dye from gaps between parts, screw threads, and others using a cotton swab or similar materials.

6. Use a UV lamp to check that no fluorescent leak detection dye remains after finishing work.

**WARNING:**

**Do not look directly into UV lamp light source.**

**NOTE:**

- For continuous operating time of UV lamp, follow the manufacturer operating instructions.
- Dust, dirt, and packing materials adhesive used for condenser, evaporator, and other locations may fluoresce. Be careful not to misidentify leakage.

## CHECK REFRIGERANT LEAKAGE USING ELECTRONIC LEAK DETECTOR

**WARNING:**

**Do not check refrigerant leakage while the engine is running.**

**CAUTION:**

**Be careful of the following items so that inaccurate checks or misidentifications are avoided.**

- **Do not allow refrigerant vapor, shop chemical vapors, cigarette smoke or others around the vehicle.**
- **Always check refrigerant leakage in a low air flow environment so that refrigerant may not disperse when leakage occurs.**

1. Stop the engine.
2. Connect recovery/recycling/recharging equipment or manifold gauge set to A/C service valve.
3. Check that A/C refrigerant pressure is 345 kPa (3.52 kg/cm<sup>2</sup>, 50 psi) or more when temperature is 16°C (61°F) or more. When pressure is lower than the specified value, recycle refrigerant completely and fill refrigerant to the specified level.

**NOTE:**

Leakages may not be detected if A/C refrigerant pressure is 345 kPa (3.52 kg/cm<sup>2</sup>, 50 psi) or less when temperature is less than 16°C (61°F).

4. Clean area where refrigerant leakage check is performed and check refrigerant leakage along all surfaces of pipe connections and A/C system components using electronic leak detector probe.

**CAUTION:**

- **Continue checking when a leakage is found. Always continue and complete checking along all pipe connections and A/C system components for additional leakage.**
- **When a leakage is detected, clean leakage area using compressed air and check again.**
- **When checking leakage of cooling unit inside, always clean inside of drain hose so that the probe surface may not be exposed to water or dirt.**

**NOTE:**

- Always check leakage starting from high-pressure side and continue to low-pressure side.
- When checking leakage of cooling unit inside, operate blower fan motor for 15 minutes or more at the maximum fan speed while the engine is stopped, and then insert electrical leak detector probe into drain hose and hold for 10 minutes or more.
- When disconnecting shut-off valve that is connected to A/C service valve, always evacuate remaining refrigerant so that misidentification can be avoided.

5. Repair or replace parts where refrigerant leakage is detected.
6. Start the engine and set A/C control in the following conditions.
  - A/C switch ON

# REFRIGERANT

## < PERIODIC MAINTENANCE >

- Air flow: VENT (ventilation)
  - Intake door position: Recirculation
  - Temperature setting: Full cold
  - Fan (blower) speed: Maximum speed set
7. Run the engine at approximately 1,500 rpm for 2 minutes or more.
  8. Stop the engine. Check again for refrigerant leakage. Go to step 4.

### **WARNING:**

**Be careful not to get burned when the engine is hot.**

### **NOTE:**

- Start refrigerant leakage check immediately after the engine is stopped.
- When refrigerant circulation is stopped, pressure on the low-pressure side rises gradually, and after this, pressure on the high-pressure side falls gradually.
- The higher the pressure is, the easier it is to find the refrigerant leakage.

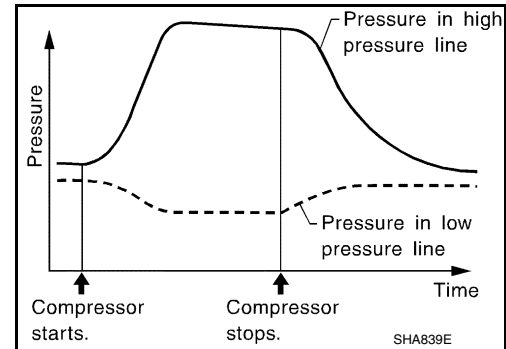

## Recycle Refrigerant

INFOID:0000000012551267

### **WARNING:**

- Always use HFC-134a for A/C refrigerant. If CFC-12 is accidentally charged, compressor is damaged due to insufficient lubrication.
  - Always observe and follow precautions described on refrigerant container. Incorrect handling may result in an explosion of refrigerant container, frostbite or the loss of eyesight.
  - Do not breathe A/C refrigerant and oil vapor or mist. Exposure may irritate eyes, nose, or throat.
  - Do not allow HFC-134a to be exposed to an open flame or others because it generates poisonous gas when in contact with high temperature objects. Keep workshop well ventilated.
1. Perform oil return operation. Refer to [HA-25. "Perform Oil Return Operation"](#). (If refrigerant or oil leakage is detected in a large amount, omit this step, and go to step 2.)

### **CAUTION:**

**Do not perform oil return operation if a large amount of refrigerant or oil leakage is detected.**

2. Check gauge pressure readings of recovery/recycling/recharging equipment. When remaining pressure exists, recycle refrigerant from high-pressure hose and low-pressure hose.

### **NOTE:**

Follow manufacturer instructions for the handling or maintenance of the equipment. Do not fill the equipment with non-specified refrigerant.

3. Remove A/C service valve cap from the vehicle.
4. Connect recovery/recycling/recharging equipment to A/C service valve.
5. Operate recovery/recycling/recharging equipment, and recycle refrigerant from the vehicle.
6. Evacuate air for 10 minutes or more to remove any remaining refrigerant integrated to compressor oil, etc.
7. Refrigerant recycle operation is complete.

## Charge Refrigerant

INFOID:0000000012551268

### **WARNING:**

- Always use HFC-134a for A/C refrigerant. If CFC-12 is accidentally charged, compressor is damaged due to insufficient lubrication.
  - Always observe and follow precautions described on refrigerant container. Incorrect handling may result in an explosion of refrigerant container, frostbite, or the loss of eyesight.
  - Do not breathe A/C refrigerant and oil vapor or mist. Exposure may irritate eyes, nose, or throat.
  - Do not allow HFC-134a to be exposed to an open flame or others because it generates poisonous gas when in contact with high temperature objects. Keep workshop well ventilated.
1. Connect recovery/recycling/recharging equipment to the A/C service valve.

# REFRIGERANT

## < PERIODIC MAINTENANCE >

---

2. Operate recovery/recycling/recharging equipment, and evacuate air from A/C system for 25 minutes or more.

**CAUTION:**

**Evacuate air for 15 minutes or more if the parts are replaced.**

3. Check the airtightness of A/C system for 25 minutes or more. If pressure raises more than the specified level, charge A/C system with approximately 200g refrigerant and check that there is no refrigerant leakage. Refer to [HA-21, "Leak Test"](#).

**CAUTION:**

**Check the airtightness for 15 minutes or more if the parts are replaced.**

4. If parts other than compressor are replaced, fill compressor oil according to parts that are replaced.
5. Charge the specified amount of refrigerant to A/C system.
6. Check that A/C system operates normally.
7. Disconnect recovery/recycling/recharging equipment. (Collect the refrigerant from the high-pressure hose and low-pressure hose of recovery/recycling/recharging equipment.)
8. Install A/C service valve cap.
9. Refrigerant charge is complete.



# OIL

< PERIODIC MAINTENANCE >

## OIL

### Description

INFOID:000000012551269

### MAINTENANCE OF OIL LEVEL

The compressor oil is circulating in the system together with the refrigerant. It is necessary to fill compressor with oil when replacing A/C system parts or when a large amount of refrigerant leakage is detected. It is important to always maintain oil level within the specified level or otherwise the following conditions may occur:

- Insufficient oil amount: Stuck compressor
- Excessive oil amount: Insufficient cooling (caused by insufficient heat exchange)

**Oil Type : A/C System Oil Type S**

### Inspection

INFOID:000000012551270

If a compressor is malfunctioning (internal noise, insufficient cooling), check the compressor oil.

#### 1. COMPRESSOR OIL JUDGMENT

1. Remove the compressor. Refer to [HA-30, "COMPRESSOR : Removal and Installation"](#).
2. Sample compressor oil and judge below according to the figure.

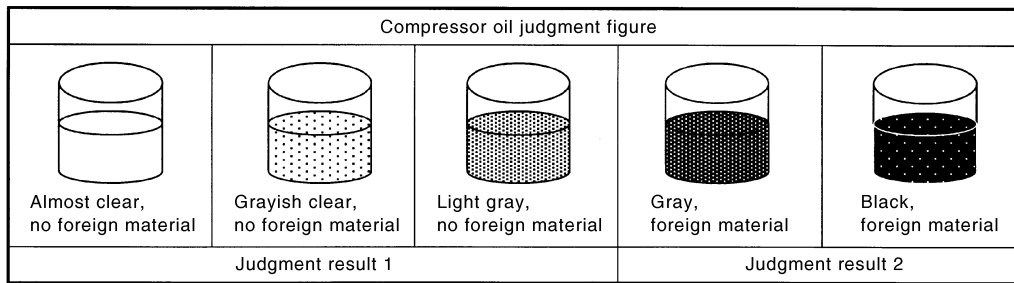

JSIIA0927GB

Judgement result 1>>Replace compressor only.

Judgement result 2>>Replace compressor and condenser (includes liquid tank).

### Perform Oil Return Operation

INFOID:000000012551271

#### CAUTION:

**If a large amount of refrigerant or oil leakage is detected, do not perform oil return operation.**

1. Start the engine and set to the following conditions:
  - Engine speed: Idling to 1,200 rpm
  - A/C switch: ON
  - Fan (blower) speed: Maximum speed set
  - Intake door position: Recirculation
  - Temperature setting: Full cold
2. Perform oil return operation for approximately 10 minutes.
3. Stop the engine.
4. Oil return operation is complete.

### Oil Adjusting Procedure for Components Replacement Except Compressor

INFOID:000000012551272

Fill with oil for the amount that is calculated according to the following conditions.

Example: Oil amount to be added when replacing evaporator [m ℓ (US fl oz, Imp fl oz)] = 75 (2.5, 2.6) + α

Conditions	Oil amount to be added to A/C system m ℓ (US fl oz, Imp fl oz)
Replace evaporator	75 (2.5, 2.6)
Replace condenser (includes liquid tank)	80 (2.7, 2.8)

# OIL

## < PERIODIC MAINTENANCE >

Conditions		Oil amount to be added to A/C system m ℓ (US fl oz, Imp fl oz)
Refrigerant leakage is detected	Large amount leakage	30 (1.0, 1.1)
	Small amount leakage	—
Oil amount that is recycled together with refrigerant during recycle operation		α

### Oil Adjusting Procedure for Compressor Replacement

INFOID:0000000012551273

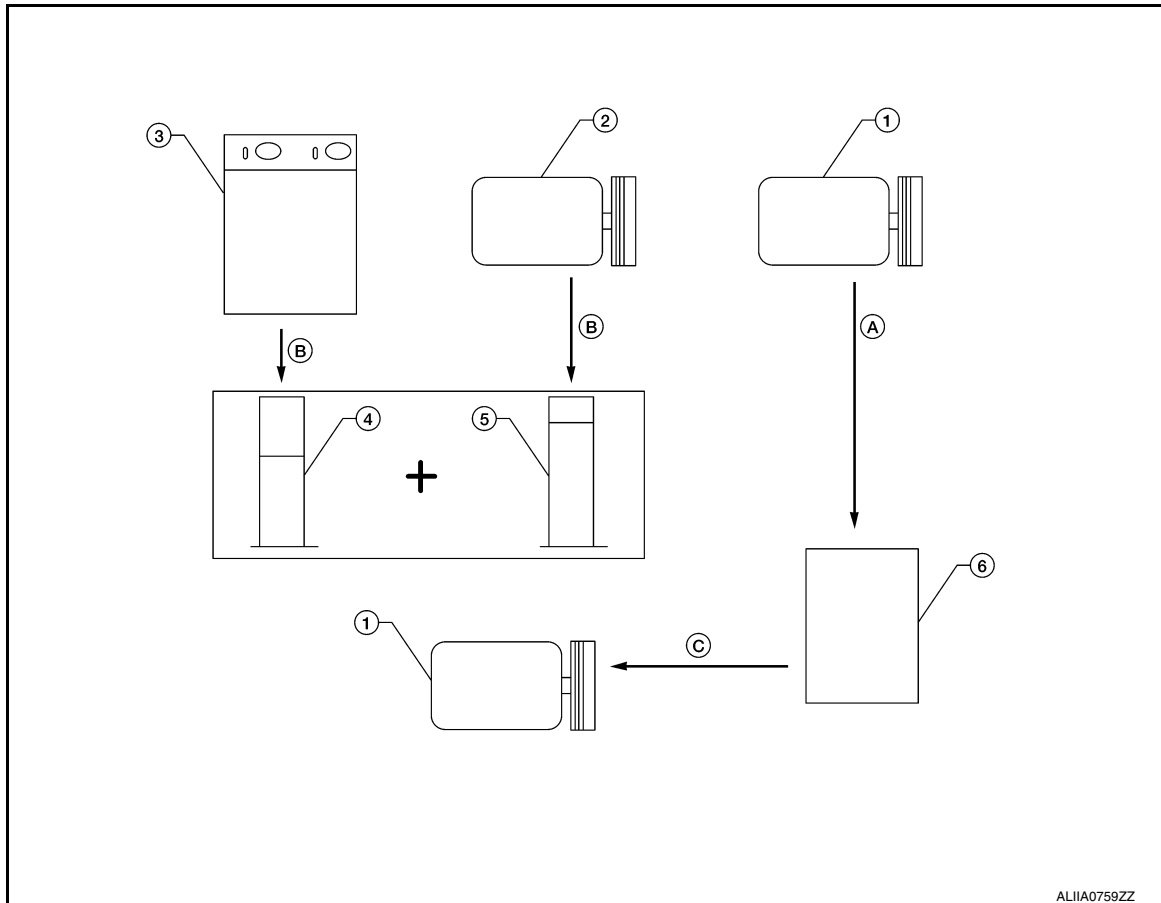

- |   |                                   |  |
|---|-----------------------------------|--|
| 1. New compressor   | 2. Old compressor                 | 3. Recovery/recycling equipment  |
| 4. Measuring cup X  | 5. Measuring cup Y                | 6. New oil   |
| A. Drain oil from the new compressor into clean container | B. Record amount of oil recovered | C. Install new oil equal to recorded amounts in measuring cups X and Y |

- Before connecting recovery/recycling equipment to vehicle, check recovery/recycling equipment gauges. No refrigerant pressure should be displayed. If NG, recover refrigerant from equipment lines.
- Connect recovery/recycling equipment to vehicle. Confirm refrigerant purity in supply tank using recovery/recycling equipment and refrigerant identifier. If NG, refer to [HA-4, "Precautions For Refrigerant System Service"](#).
- Confirm refrigerant purity in vehicle A/C system using recovery/recycling equipment and refrigerant identifier. If NG, refer to [HA-4, "Precautions For Refrigerant System Service"](#).
- Discharge refrigerant into the refrigerant recovery/recycling equipment. Measure oil discharged into the recovery/recycling equipment.
- Drain the oil from the "old" (removed) compressor into a graduated container and recover the amount of oil drained.
- Drain the oil from the "new" compressor into a separate, clean container.
- Measure an amount of new oil installed equal to amount drained from "old" compressor. Add this oil to "new" compressor through the suction port opening.

# OIL

## < PERIODIC MAINTENANCE >

---

8. Measure an amount of new oil equal to the amount recovered during discharging. Add this oil to “new” compressor through the suction port opening.

A

B

C

D

E

F

G

H

**HA**

J

K

L

M

N

O

P

# PERFORMANCE TEST

< PERIODIC MAINTENANCE >

## PERFORMANCE TEST

### Inspection

INFOID:000000012551274

#### INSPECTION PROCEDURE

1. Connect recovery/recycling/recharging equipment (for HFC-134a) or manifold gauge.
2. Start the engine, and set to the following condition.

Test condition		
Surrounding condition		Indoors or in the shade (in a well-ventilated place)
Vehicle condition	Door	Closed
	Door glass	Full open
	Hood	Open
	Engine speed	Idle speed
A/C condition	Temperature control switch or dial	Full cold
	A/C switch	ON
	Air outlet	VENT (ventilation)
	Intake door position	Recirculation
	Fan (blower) speed	Maximum speed set

3. Maintain test condition until A/C system becomes stable. (Approximately 10 minutes)
4. Check that test results of “recirculating-to-discharge air temperature” and “ambient air temperature-to-operating pressure” are within the specified value.
5. When test results are within the specified value, inspection is complete.  
If any of test result is out of the specified value, perform diagnosis by gauge pressure. Refer to [HA-18, "Symptom Table"](#).

#### RECIRCULATING-TO-DISCHARGE AIR TEMPERATURE TABLE

Inside air (Recirculating air) at blower assembly inlet		Discharge air temperature from center ventilator °C (°F)
Relative humidity %	Air temperature °C (°F)	
50 – 60	20 (68)	4.7 – 6.7 (40 – 44)
	25 (77)	8.6 – 11.1 (47 – 52)
	30 (86)	12.6 – 15.6 (55 – 60)
	35 (95)	19.0 – 22.5 (66 – 73)
60 – 70	20 (68)	6.7 – 8.7 (44 – 48)
	25 (77)	11.1 – 13.6 (52 – 56)
	30 (86)	15.6 – 18.6 (60 – 65)
	35 (95)	22.5 – 26.0 (73 – 79)

#### AMBIENT AIR TEMPERATURE-TO-OPERATING PRESSURE TABLE

# PERFORMANCE TEST

< PERIODIC MAINTENANCE >

Fresh air		High-pressure (Discharge side) kPa (kg/cm <sup>2</sup> , psi)	Low-pressure (Suction side) kPa (kg/cm <sup>2</sup> , psi)	A
Relative humidity %	Air temperature °C (°F)			
50 – 70	25 (77)	909 – 1,112 (9.2 – 11.3, 131.8 – 161.2)	159 – 194 (1.6 – 2.0, 23.1 – 28.1)	B
	30 (86)	1,073 – 1,312 (10.9 – 13.4, 155.6 – 190.2)	211 – 259 (2.2 – 2.6, 30.6 – 37.6)	C
	35 (95)	1,445 – 1,766 (14.7 – 18.0, 209.5 – 256.1)	247 – 300 (2.5 – 3.1, 35.8 – 43.5)	D
	40 (104)	1,650 – 2,017 (16.8 – 20.6, 239.3 – 292.5)	290 – 355 (3.0 – 3.6, 42.1 – 51.5)	E

E

F

G

H

HA

J

K

L

M

N

O

P

# COMPRESSOR

< REMOVAL AND INSTALLATION >

## REMOVAL AND INSTALLATION

### COMPRESSOR

Exploded View

INFOID:000000012551275

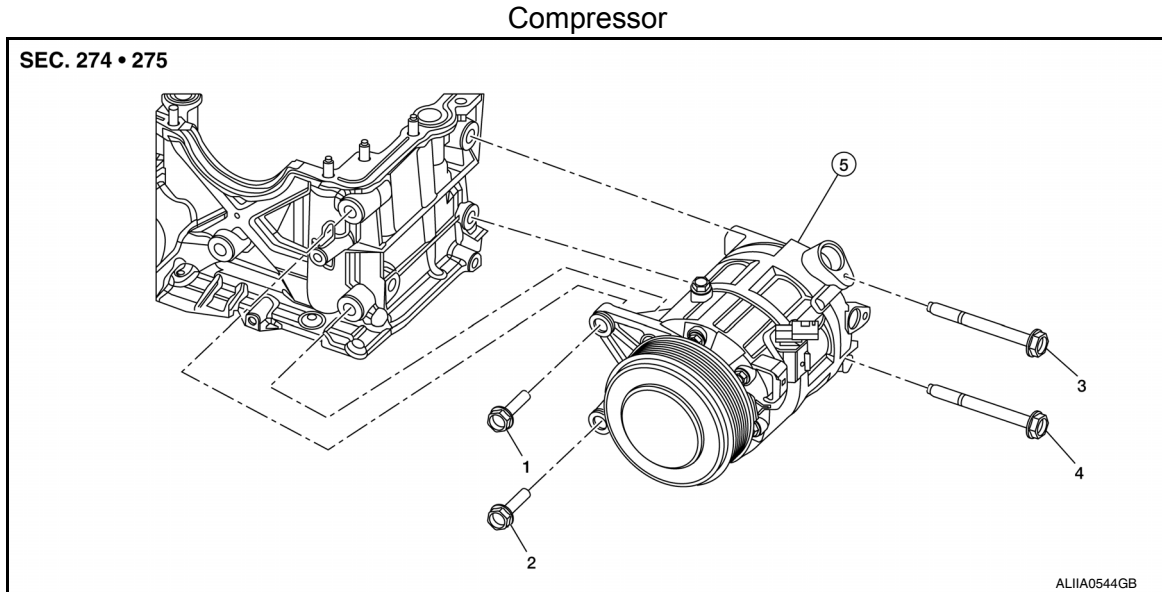

1-4: Tighten bolts in order shown

5. Compressor

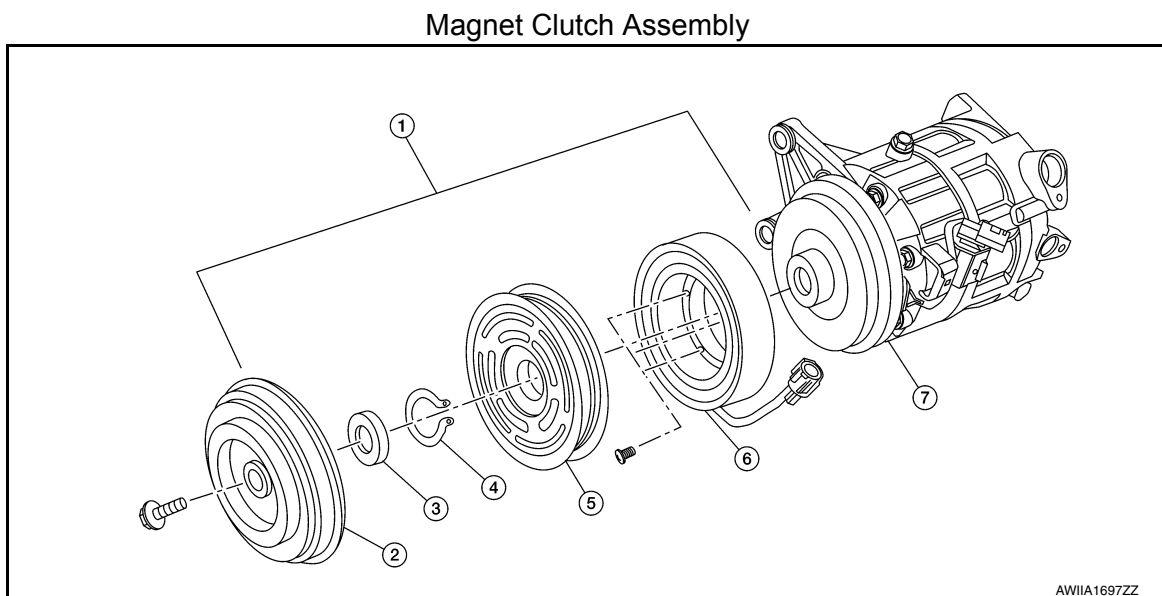

1. Magnet clutch assembly

2. Clutch disc

3. Shim

4. Snap ring

5. Pulley

6. Magnet coil

7. Compressor

## COMPRESSOR

### COMPRESSOR : Removal and Installation

INFOID:000000012551276

#### REMOVAL

Revision: November 2015

HA-30

2016 Pathfinder

# COMPRESSOR

## < REMOVAL AND INSTALLATION >

1. Discharge the refrigerant. Refer to [HA-23, "Recycle Refrigerant"](#).
2. Partially remove the front edge of the front fender protector (RH). Refer to [EXT-28, "FENDER PROTECTOR : Removal and Installation"](#).
3. Remove the bolts that retain the oil cooler line brackets to the engine block and reposition the oil cooler line aside. Refer to [LU-15, "Removal and Installation"](#).
4. Remove the drive belt. Refer to [EM-12, "Removal and Installation"](#).
5. Disconnect the harness connector from the compressor.
6. Disconnect the low-pressure flexible hose from the compressor.  
**CAUTION:**  
**Cap or wrap the joint of the pipe with suitable material such as vinyl tape to avoid the entry of air.**
7. Disconnect the high-pressure flexible hose from the compressor.  
**CAUTION:**  
**Cap or wrap the joint of the pipe with suitable material such as vinyl tape to avoid the entry of air.**
8. Remove the compressor bolts, then remove the compressor.

## INSTALLATION

1. Install the compressor and compressor bolts. Tighten the compressor bolts to specification and in the sequence as shown.  
**CAUTION:**
  - Tighten the compressor bolts in the specified sequence.
  - Do not reuse O-rings.
  - Apply A/C oil to new O-rings for installation.

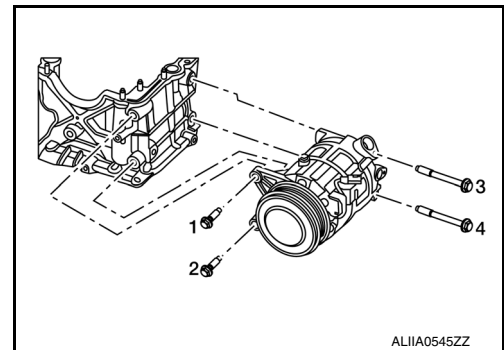

2. Connect the harness connector to the compressor.
3. Connect the high-pressure flexible hose to the compressor.
4. Connect the low-pressure flexible hose to the compressor.
5. Install the drive belt. Refer to [EM-12, "Removal and Installation"](#).  
**CAUTION:**  
**Check the tension of the drive belt after installing the compressor. Refer to [EM-12, "Checking Drive Belt"](#).**
6. Install the bolts that retain the oil cooler line brackets to the engine block. Refer to [LU-15, "Removal and Installation"](#).
7. Install the front fender protector (RH). Refer to [EXT-28, "FENDER PROTECTOR : Removal and Installation"](#).
8. Recharge the refrigerant. Refer to [HA-23, "Charge Refrigerant"](#).  
**CAUTION:**  
**After charging refrigerant, check for leaks. Refer to [HA-21, "Leak Test"](#).**

## MAGNET CLUTCH

### MAGNET CLUTCH : Removal and Installation of Compressor Clutch

INFOID:000000012551277

## REMOVAL

1. Remove the compressor. Refer to [HA-30, "COMPRESSOR : Removal and Installation"](#).
2. Remove the center bolt by holding the clutch disc steady using a suitable tool.
3. Remove the clutch disc and shims.  
**CAUTION:**  
**Retain all the shims for installation.**

# COMPRESSOR

## < REMOVAL AND INSTALLATION >

4. Remove the snap ring using a suitable tool as shown.

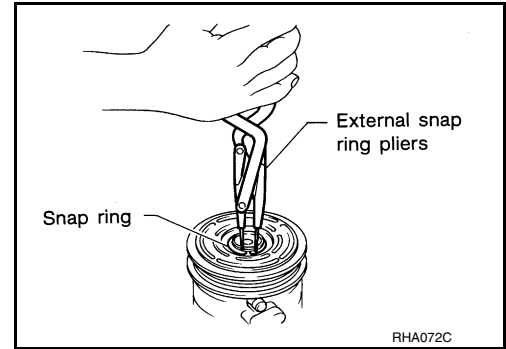

5. Remove the pulley assembly using a suitable tool (A) as shown.

**CAUTION:**

To prevent deformation of the pulley groove, the puller claws should be hooked under (not into) the pulley groove.

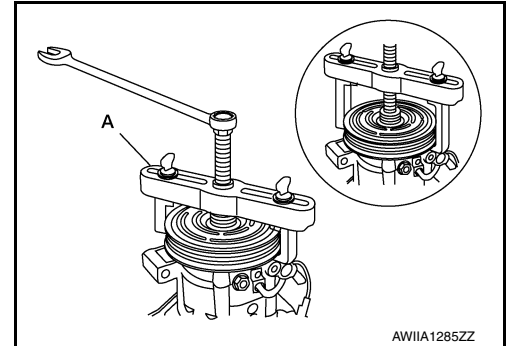

6. Disconnect the harness connector from magnet coil.

7. Remove the three magnet coil screws using a suitable tool as shown and remove.

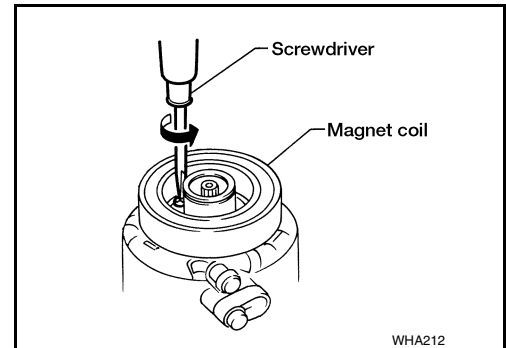

## INSPECTION AFTER REMOVAL

- (1): Shim
- (2): Snap ring
- (3): Clutch disc
- (4): Pulley
- (5): Magnet coil
- (A): Center bolt
- (B): Magnet coil screws

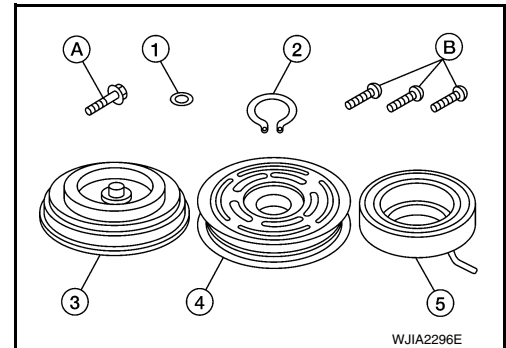

### Clutch Disc

If the contact surface shows signs of damage due to excessive heat, replace as necessary.

### Pulley

Check the appearance of the pulley assembly. If the contact surface of the pulley shows signs of excessive grooving, replace as necessary. The contact surfaces of the pulley assembly should be cleaned with a suitable solvent before installation.

### Magnet Coil

Check the magnet coil for a loose connection or cracked insulation. Replace as necessary.



# COMPRESSOR

## < REMOVAL AND INSTALLATION >

### INSTALLATION

1. Install the magnet coil by aligning the magnet coil pin (A) with the hole (B) in the compressor front head as shown, then install the magnet coil screws.

⇐: Rear

**CAUTION:**

**Be sure to align the magnet coil pin with the hole in the compressor front head.**

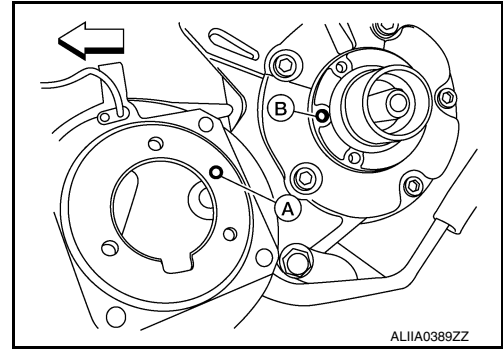

2. Connect the magnet coil harness connector.
3. Install the pulley assembly using Tool and a wrench as shown, then install the snap ring using a suitable tool.

**Tool number : — (J-38873-A)**

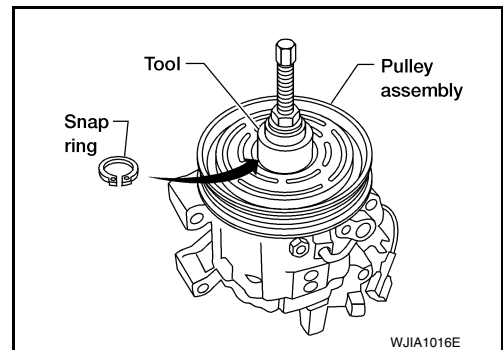

4. Install the clutch disc (1) on the drive shaft, together with all of the original shims (2) using a suitable tool (A).

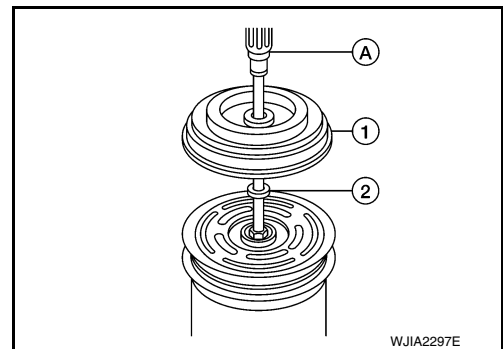

5. Install the center bolt using a suitable tool.
6. Install the compressor. Refer to [HA-30, "COMPRESSOR : Removal and Installation"](#).

### INSPECTION AFTER INSTALLATION

Check the clearance (B) all the way around between the clutch disc (1) and pulley (2) using a suitable tool (A) as shown.

**Clutch disc-to-pulley clearance (B) : 0.3 - 0.6 mm  
(0.01 - 0.02 in)**

If the specified clearance (B) is not obtained, replace the adjusting shims and recheck the clearance (B) as shown.

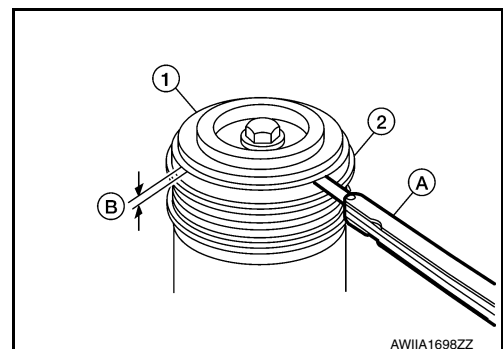

### BREAK-IN OPERATION

When replacing compressor clutch assembly, always conduct the break-in operation. This is done by engaging and disengaging the clutch about 30 times. Break-in operation raises the level of transmitted torque.

# COOLER PIPE AND HOSE

< REMOVAL AND INSTALLATION >

## COOLER PIPE AND HOSE

Exploded View

INFOID:000000012551278

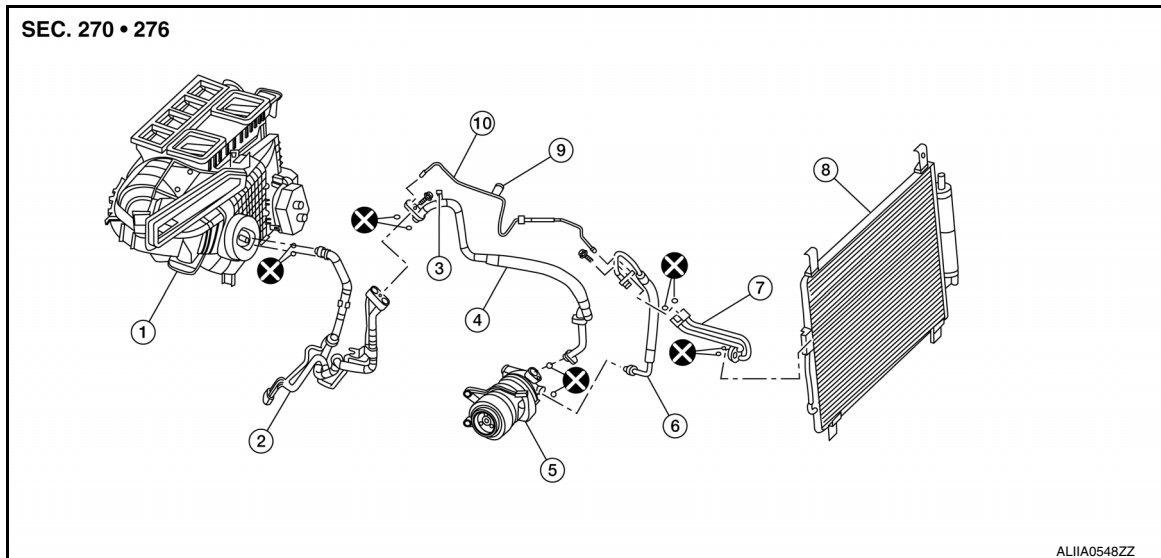

- |  |  |                                |
|--|--|--------------------------------|
| 1. Front heating and cooling unit assembly | 2. High-pressure and low-pressure pipe | 3. Low-pressure service port   |
| 4. Low-pressure flexible hose              | 5. Compressor                          | 6. High-pressure flexible hose |
| 7. Condenser pipe assembly                 | 8. Condenser (includes liquid tank)    | 9. High-pressure service port  |
| 10. High-pressure pipe                     |  |                                |

## HIGH-PRESSURE AND LOW-PRESSURE PIPE

### HIGH-PRESSURE AND LOW-PRESSURE PIPE : Removal and Installation

INFOID:000000012551279

#### REMOVAL

1. Discharge the refrigerant. Refer to [HA-23, "Recycle Refrigerant"](#).
2. Remove core support cover. Refer to [EXT-16, "Exploded View"](#).
3. Remove front air duct. Refer to [EM-24, "Removal and Installation"](#).
4. Remove front under cover. Refer to [EXT-30, "Removal and Installation"](#).
5. Remove the cowl top extension. Refer to [EXT-25, "Exploded View"](#).
6. Remove the high-pressure and low-pressure pipe bolt from the expansion valve.  
**CAUTION:**  
**Cap or wrap the joint of the pipe with suitable material such as vinyl tape to avoid the entry of air.**
7. Remove the high-pressure and low-pressure pipe bolt from the underfloor rear high-pressure and low-pressure A/C pipes.  
**CAUTION:**  
**Cap or wrap the joint of the pipe with suitable material such as vinyl tape to avoid the entry of air.**
8. Remove the high-pressure and low-pressure pipe bolt from the low-pressure flexible hose and high-pressure pipe.  
**CAUTION:**  
**Cap or wrap the joint of the pipe with suitable material such as vinyl tape to avoid the entry of air.**
9. Remove the high-pressure and low-pressure pipe.

#### INSTALLATION

Installation is in the reverse order of removal.

#### **CAUTION:**

- Do not reuse O-rings.
- Apply A/C oil to the O-rings of the high-pressure and low-pressure pipe for installation.

# COOLER PIPE AND HOSE

## < REMOVAL AND INSTALLATION >

- After charging refrigerant, check for leaks. Refer to [HA-21, "Leak Test"](#).

### LOW-PRESSURE FLEXIBLE HOSE

#### LOW-PRESSURE FLEXIBLE HOSE : Removal and Installation

INFOID:0000000012551280

##### REMOVAL

1. Discharge the refrigerant. Refer to [HA-23, "Recycle Refrigerant"](#).
2. Remove the front under cover. Refer to [EXT-30, "Removal and Installation"](#).
3. Remove the low-pressure flexible hose bolt from the high-pressure and low-pressure pipe.  
**CAUTION:**  
**Cap or wrap the joint of the pipe with suitable material such as vinyl tape to avoid the entry of air.**
4. Remove the low-pressure flexible hose bolt from the compressor.  
**CAUTION:**  
**Cap or wrap the joint of the pipe with suitable material such as vinyl tape to avoid the entry of air.**
5. Remove the low-pressure flexible hose.

##### INSTALLATION

Installation is in the reverse order of removal.

##### **CAUTION:**

- Do not reuse O-rings.
- Apply A/C oil to the O-rings of the low-pressure flexible hose for installation.
- After charging refrigerant, check for leaks. Refer to [HA-21, "Leak Test"](#).

### HIGH-PRESSURE PIPE

#### HIGH-PRESSURE PIPE : Removal and Installation

INFOID:0000000012551281

##### REMOVAL

1. Discharge the refrigerant. Refer to [HA-23, "Recycle Refrigerant"](#).
2. Remove core support cover. Refer to [EXT-16, "Exploded View"](#).
3. Remove front air duct. Refer to [EM-24, "Removal and Installation"](#).
4. Remove front under cover. Refer to [EXT-30, "Removal and Installation"](#).
5. Remove the high-pressure pipe bolt from the high-pressure and low-pressure pipe.  
**CAUTION:**  
**Cap or wrap the joint of the pipe with suitable material such as vinyl tape to avoid the entry of air.**
6. Remove the high-pressure pipe bolt from the condenser pipe assembly.  
**CAUTION:**  
**Cap or wrap the joint of the pipe with suitable material such as vinyl tape to avoid the entry of air.**
7. Remove clip that retains the high-pressure pipe.
8. Remove the high-pressure pipe.

##### INSTALLATION

Installation is in the reverse order of removal.

##### **CAUTION:**

- Do not reuse O-rings.
- Apply A/C oil to the O-rings of the high-pressure pipe for installation.
- After charging the refrigerant, check for leaks. Refer to [HA-21, "Leak Test"](#).

### HIGH-PRESSURE FLEXIBLE HOSE

#### HIGH-PRESSURE FLEXIBLE HOSE : Removal and Installation

INFOID:0000000012551282

##### REMOVAL

1. Discharge the refrigerant. Refer to [HA-23, "Recycle Refrigerant"](#).
2. Remove the front air duct. Refer to [EM-24, "Removal and Installation"](#).
3. Remove the core support cover. Refer to [EXT-16, "Exploded View"](#).
4. Remove the front under cover. Refer to [EXT-30, "Removal and Installation"](#).

A  
B  
C  
D  
E  
F  
G  
H  
HA  
J  
K  
L  
M  
N  
O  
P

# COOLER PIPE AND HOSE

## < REMOVAL AND INSTALLATION >

- Remove the high-pressure flexible hose bolt from the condenser pipe assembly.  
**CAUTION:**  
Cap or wrap the joint of the pipe with suitable material such as vinyl tape to avoid the entry of air.
- Remove the high-pressure flexible hose from the compressor.  
**CAUTION:**  
Cap or wrap the joint of the pipe with suitable material such as vinyl tape to avoid the entry of air.
- Remove the high-pressure flexible hose.

## INSTALLATION

Installation is in the reverse order of removal.

### **CAUTION:**

- Do not reuse O-rings.
- Apply A/C oil to the O-rings of the high-pressure flexible hose for installation.
- After charging the refrigerant, check for leaks. Refer to [HA-21, "Leak Test"](#).

## UNDERFLOOR REAR HIGH-PRESSURE AND LOW-PRESSURE A/C PIPES

### UNDERFLOOR REAR HIGH-PRESSURE AND LOW-PRESSURE A/C PIPES : Exploded View

INFOID:000000012551283

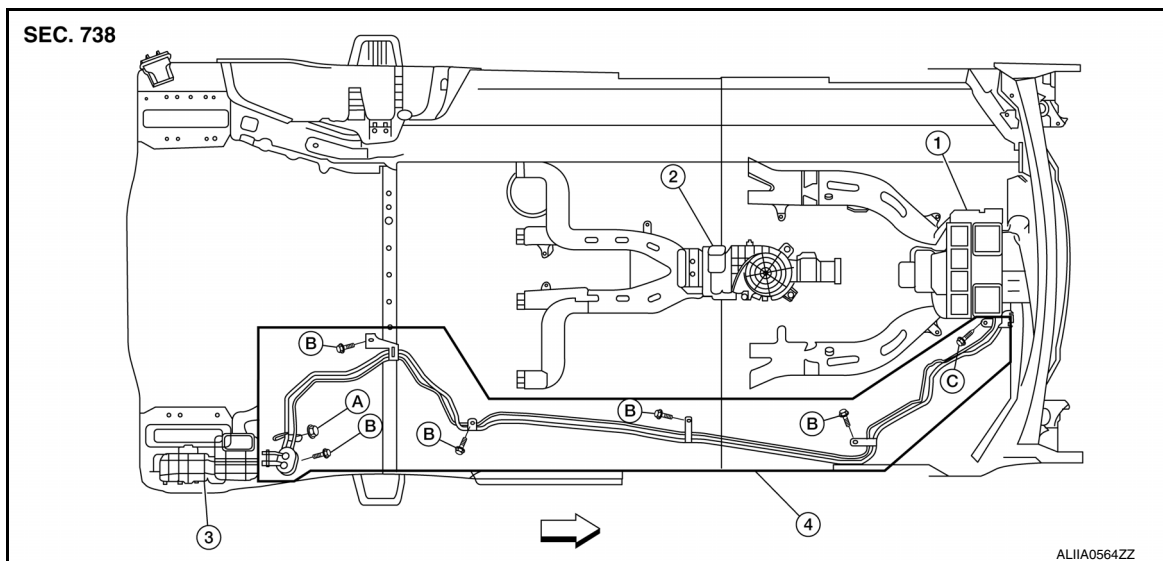

- |  |                                      |                               |
|--|--------------------------------------|-------------------------------|
| 1. Front heating and cooling unit assembly     | 2. Rear blower motor 1 unit assembly | 3. Rear cooling unit assembly |
| 4. Rear underfloor high and low-pressure pipes | A. Nut                               | B. Bolt                       |
| C. Screw                                       | ⇐ Front                              |                               |

### UNDERFLOOR REAR HIGH-PRESSURE AND LOW-PRESSURE A/C PIPES : Removal and Installation

INFOID:000000012551284

## REMOVAL

- Discharge the refrigerant. Refer to [HA-23, "Recycle Refrigerant"](#).
- Remove the engine room cover.
- Remove the front air duct. Refer to [EM-24, "Removal and Installation"](#).
- Remove the cowl top extension. Refer to [EXT-25, "Removal and Installation"](#).
- Disconnect the underfloor rear high-pressure and low-pressure A/C pipes from the high-pressure and low-pressure pipe.  
**CAUTION:**  
Cap or wrap the joint of the pipe with suitable material such as vinyl tape to avoid the entry of air.
- Remove the front exhaust tube. Refer to [EX-5, "Exploded View"](#).

## COOLER PIPE AND HOSE

### < REMOVAL AND INSTALLATION >

7. Remove the propeller shaft assembly (4WD only). Refer to [DLN-102, "Removal and Installation"](#).
8. Disconnect the underfloor rear high-pressure and low-pressure A/C pipes from the rear cooling unit assembly.  
**CAUTION:**  
**Cap or wrap the joint of the pipe with suitable material such as vinyl tape to avoid the entry of air.**
9. Lower the rear suspension member to allow room to remove the underfloor rear high-pressure and low-pressure A/C pipes. Refer to [RSU-8, "Exploded View"](#).
10. Remove the underfloor rear high-pressure and low-pressure pipes bracket bolts, then remove the underfloor rear high-pressure and low-pressure A/C pipes.

### INSTALLATION

Installation is in the reverse order of removal.

#### **CAUTION:**

- Do not reuse O-rings.
- Apply A/C oil to new O-rings for installation.
- After charging refrigerant, check for leaks. Refer to [HA-21, "Leak Test"](#).

A  
B  
C  
D  
E  
F  
G  
H  
HA  
J  
K  
L  
M  
N  
O  
P

# CONDENSER

< REMOVAL AND INSTALLATION >

## CONDENSER

Exploded View

INFOID:000000012551285

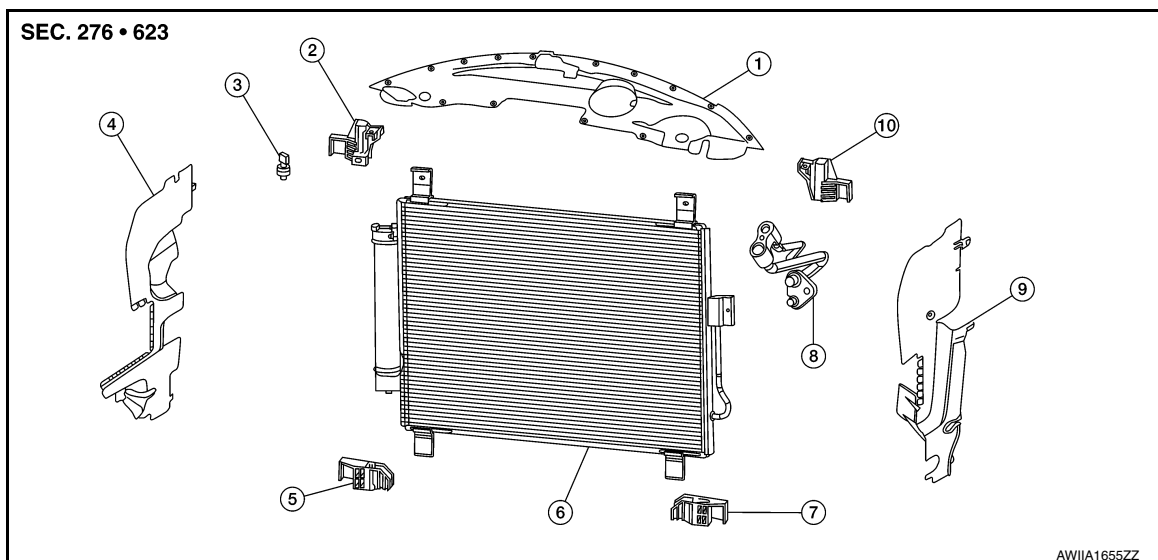

- |                                  |                                 |                                     |
|----------------------------------|---------------------------------|-------------------------------------|
| 1. Core support cover            | 2. Condenser upper bracket (LH) | 3. Refrigerant pressure sensor      |
| 4. Condenser air deflector (LH)  | 5. Condenser lower bracket (LH) | 6. Condenser (includes liquid tank) |
| 7. Condenser lower bracket (RH)  | 8. Condenser pipe assembly      | 9. Condenser air deflector (RH)     |
| 10. Condenser upper bracket (RH) |                                 |                                     |

## CONDENSER

### CONDENSER : Removal and Installation

INFOID:000000012551286

#### REMOVAL

1. Discharge the refrigerant. Refer to [HA-23, "Recycle Refrigerant"](#).
2. Remove the front air duct. Refer to [EM-24, "Removal and Installation"](#).
3. Remove the front bumper fascia. Refer to [EXT-17, "Removal and Installation"](#).
4. Remove the hood lock assembly. Refer to [DLK-270, "HOOD LOCK RELEASE CABLE : Removal and Installation"](#).
5. Disconnect the harness connector from the refrigerant pressure sensor.
6. Remove the radiator core support center brace bolts (A) then remove the radiator core support center brace.

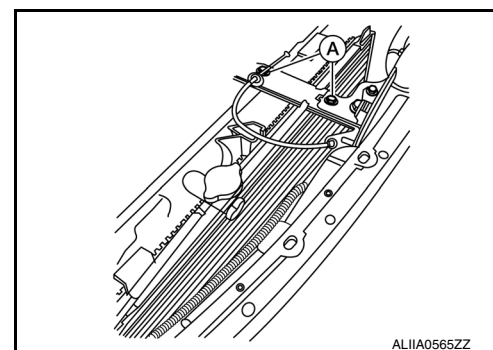

7. Remove the bolt that retains the condenser pipe assembly to the condenser, then separate the condenser pipe assembly from the condenser.  
**CAUTION:**  
**Cap or wrap the joint of the pipe with suitable material such as vinyl tape to avoid the entry of air.**
8. Remove the condenser bracket bolts.
9. Remove the condenser.

# CONDENSER

## < REMOVAL AND INSTALLATION >

10. Remove the refrigerant pressure sensor (if necessary). Refer to [HA-39, "REFRIGERANT PRESSURE SENSOR : Removal and Installation"](#).

### INSTALLATION

Installation is in the reverse order of removal.

#### CAUTION:

- Do not reuse O-rings.
- Apply A/C oil to the O-rings of the condenser for installation.
- After charging the refrigerant, check for leaks. Refer to [HA-21, "Leak Test"](#).

## CONDENSER PIPE ASSEMBLY

### CONDENSER PIPE ASSEMBLY : Removal and Installation

INFOID:000000012551287

#### REMOVAL

1. Discharge the refrigerant. Refer to [HA-23, "Recycle Refrigerant"](#).
2. Remove the core support cover. Refer to [EXT-16, "Exploded View"](#).
3. Remove the bolt that retains the condenser pipe assembly to the condenser.
4. Remove the bolt (A) that retains the condenser pipe assembly to the high-pressure flexible hose and high-pressure pipe.

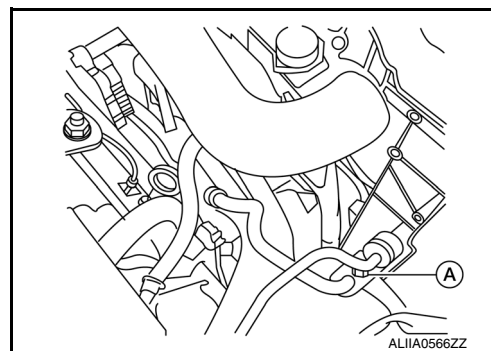

5. Remove the condenser pipe assembly.

#### CAUTION:

Cap or wrap the joint of the pipe with suitable material such as vinyl tape to avoid the entry of air.

### INSTALLATION

Installation is in the reverse order of removal.

#### CAUTION:

- Do not reuse O-rings.
- Apply A/C oil to the O-rings of the condenser pipe assembly for installation.
- After charging the refrigerant, check for leaks. Refer to [HA-21, "Leak Test"](#).

## LIQUID TANK

### LIQUID TANK : Removal and Installation

INFOID:000000012551288

The liquid tank is only serviced as part of the condenser. Refer to [HA-38, "CONDENSER : Removal and Installation"](#).

## REFRIGERANT PRESSURE SENSOR

### REFRIGERANT PRESSURE SENSOR : Removal and Installation

INFOID:000000012551289

#### REMOVAL

1. Discharge the refrigerant. Refer to [HA-23, "Recycle Refrigerant"](#).
2. Remove the core support cover. Refer to [EXT-16, "Exploded View"](#).
3. Disconnect the harness connector from the refrigerant pressure sensor.

## CONDENSER

### < REMOVAL AND INSTALLATION >

4. Remove the refrigerant pressure sensor (1).

**CAUTION:**

Cap or wrap the opening of the refrigerant pressure sensor with suitable material such as vinyl tape to avoid the entry of air.

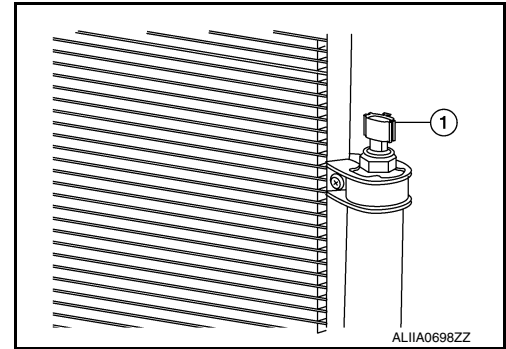

### INSTALLATION

Installation is in the reverse order of removal.

**CAUTION:**

- Do not reuse O-ring.
- Apply A/C oil to the O-ring of the refrigerant pressure sensor for installation.
- After charging the refrigerant, check for leaks. Refer to [HA-21, "Leak Test"](#).



# HEATING AND COOLING UNIT ASSEMBLY

< REMOVAL AND INSTALLATION >

## HEATING AND COOLING UNIT ASSEMBLY

## HEATING AND COOLING UNIT ASSEMBLY

## HEATING AND COOLING UNIT ASSEMBLY : Exploded View

INFOID:000000012551290

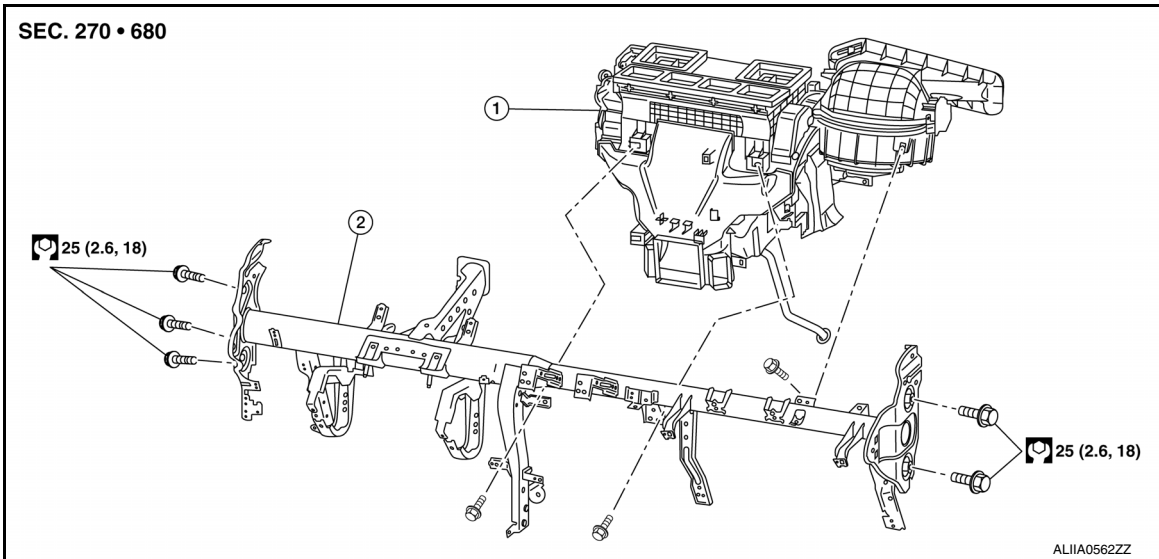

1. Front heating and cooling unit assembly

2. Steering member

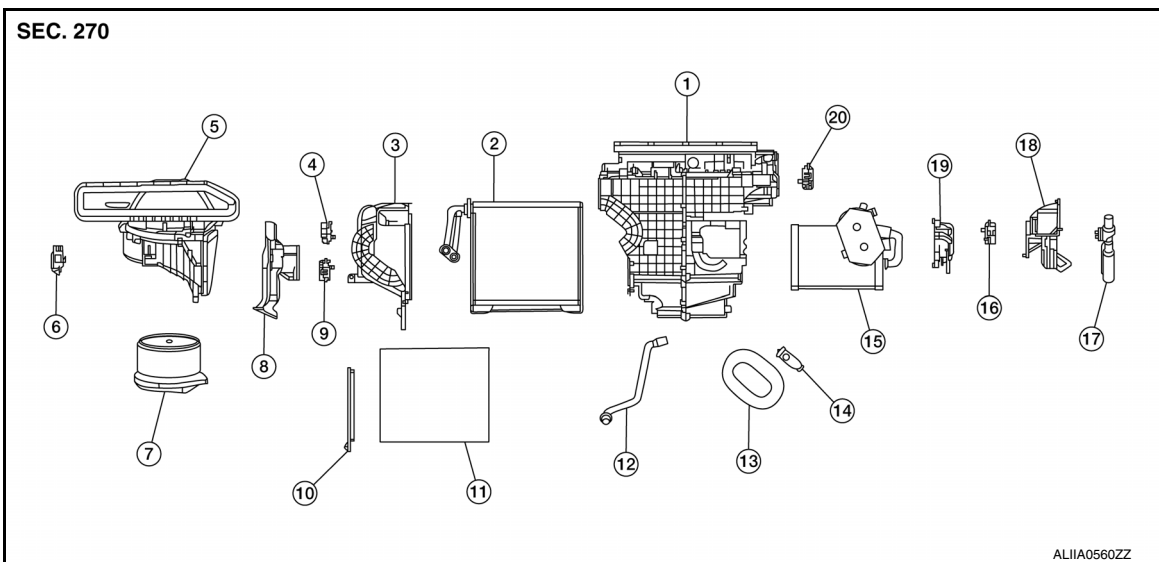

- |  |                             |                              |
|--|-----------------------------|------------------------------|
| 1. Front heating and cooling unit assembly | 2. Front evaporator         | 3. Heater case side cover    |
| 4. Air mix door motor (passenger side)     | 5. Front blower unit case   | 6. Intake door motor         |
| 7. Front blower motor                      | 8. Front foot duct (RH)     | 9. Air mix door motor (rear) |
| 10. In-cabin microfilter cover             | 11. In-cabin microfilter    | 12. Drain hose               |
| 13. Expansion valve grommet                | 14. Front expansion valve   | 15. Front heater core        |
| 16. Air mix door motor (driver side)       | 17. Aspirator hose          | 18. Front foot duct (LH)     |
| 19. Front heater core pipe cover           | 20. Mode door motor (front) |                              |

# HEATING AND COOLING UNIT ASSEMBLY

< REMOVAL AND INSTALLATION >

## HEATING AND COOLING UNIT ASSEMBLY : Removal and Installation

INFOID:000000012551291

### REMOVAL

#### **CAUTION:**

**Before servicing, turn the ignition switch off, disconnect both battery cables and wait at least three minutes.**

#### **NOTE:**

When removing components such as hoses, lines/tubes, etc., cap or plug openings to prevent fluid from leaking.

1. Disconnect the negative and positive battery terminals and wait at least three minutes. Refer to [PG-93, "Removal and Installation"](#).
2. Discharge the refrigerant. Refer to [HA-23, "Recycle Refrigerant"](#).
3. Drain the engine coolant. Refer to [CO-12, "Changing Engine Coolant"](#).
4. Remove the instrument panel assembly. Refer to [IP-15, "Removal and Installation"](#).
5. Remove the steering column. Refer to [ST-47, "Removal and Installation"](#).
6. Remove the front floor connecting duct (LH/RH). Refer to [VTL-10, "Exploded View"](#).
7. Disconnect the harness connectors (B) from the super multiple junction (SMJ) block (A).

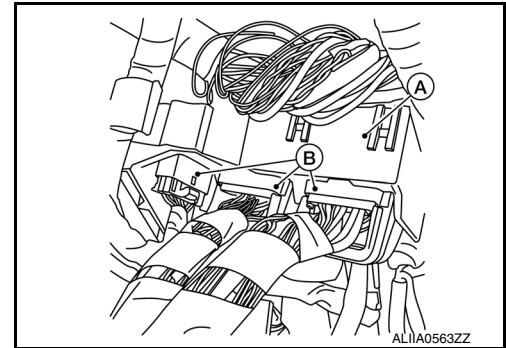

8. Disconnect the high-pressure and low-pressure pipe from the front expansion valve.  
**CAUTION:**  
**Cap or wrap the joint of the pipe with suitable material such as vinyl tape to avoid the entry of air.**
9. Disconnect the heater hoses from the front heater core.
10. Remove the cowl top extension. Refer to [EXT-25, "Removal and Installation"](#).
11. Remove the body panel plug, then remove the steering member bolt.
12. Remove the bolts that retain the steering member to the vehicle body.
13. Disconnect the front drain hose from the front heating and cooling unit assembly.
14. Disconnect the harness connectors from the front heating and cooling unit assembly and steering member.
15. Remove the front heating and cooling unit assembly and steering member from the vehicle as an assembly.  
**CAUTION:**  
**Do not damage the seats when removing the steering member.**
16. Remove the bolts that retain the front heating and cooling unit assembly to the steering member.
17. Separate the front heating and cooling unit assembly from the steering member.

### INSTALLATION

Installation is in the reverse order of removal.

# HEATING AND COOLING UNIT ASSEMBLY

< REMOVAL AND INSTALLATION >

## HEATING AND COOLING UNIT ASSEMBLY : Exploded View

INFOID:000000012551292

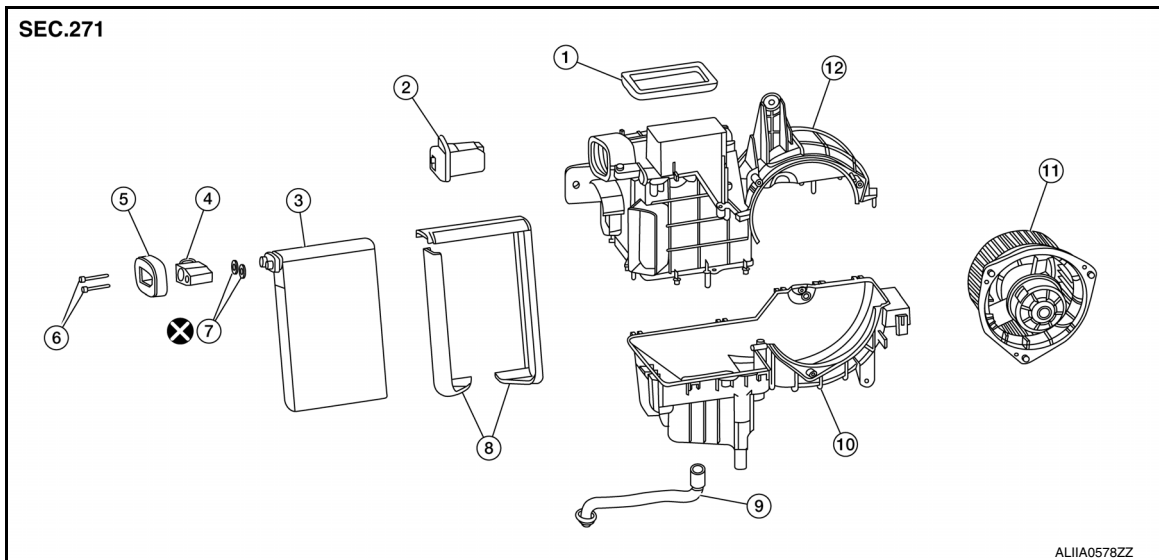

- |                                     |                                 |                                     |
|-------------------------------------|---------------------------------|-------------------------------------|
| 1. Rear ventilator duct upper seal  | 2. Rear blower motor resistor 2 | 3. Rear evaporator                  |
| 4. Rear expansion valve             | 5. Rear expansion valve grommet | 6. Rear expansion valve bolts       |
| 7. O-ring                           | 8. Rear evaporator seal         | 9. Rear drain hose                  |
| 10. Rear cooling unit lower housing | 11. Rear blower motor 2         | 12. Rear cooling unit upper housing |

## HEATING AND COOLING UNIT ASSEMBLY : Removal and Installation

INFOID:000000012551293

### REMOVAL

#### CAUTION:

Before servicing, turn the ignition switch off, disconnect both battery cables and wait at least three minutes.

1. Disconnect the negative and positive battery terminals and wait at least three minutes. Refer to [PG-93, "Removal and Installation"](#).
2. Discharge the refrigerant. Refer to [HA-23, "Recycle Refrigerant"](#).
3. Remove the back door kicking plate. Refer to [INT-36, "BACK DOOR KICKING PLATE : Removal and Installation"](#).
4. Remove the luggage side lower finisher (RH). Refer to [INT-31, "LUGGAGE SIDE LOWER FINISHER : Removal and Installation"](#).
5. Remove the storage box side finisher. Refer to [INT-33, "STORAGE BOX SIDE FINISHER : Removal and Installation"](#).
6. Remove the jack bracket bolts, then remove the jack bracket.
7. Disconnect the rear underfloor high-pressure and low-pressure pipes from the rear cooling unit assembly.  
**CAUTION:**  
**Cap or wrap the joint of the pipe with suitable material such as vinyl tape to avoid the entry of air.**
8. Remove the rear ventilator duct upper. Refer to [VTL-13, "REAR VENTILATOR DUCT UPPER : Removal and Installation"](#).
9. Remove the rear ventilator duct lower. Refer to [VTL-14, "REAR VENTILATOR DUCT LOWER : Removal and Installation"](#).
10. Disconnect the harness connectors from the rear cooling unit assembly.
11. Remove the rear cooling unit assembly bolts.
12. Disconnect the drain hose from the rear cooling unit assembly.
13. Remove the rear cooling unit assembly.

### INSTALLATION

Installation is in the reverse order of removal.

# HEATING AND COOLING UNIT ASSEMBLY

< REMOVAL AND INSTALLATION >

## CAUTION:

- Do not reuse O-rings.
- Apply A/C oil to the O-rings of the rear underfloor high-pressure and low-pressure pipes for installation.
- After charging refrigerant, check for leaks. Refer to [HA-21, "Leak Test"](#).

## HEATER CORE

HEATER CORE : Exploded View

INFOID:000000012551294

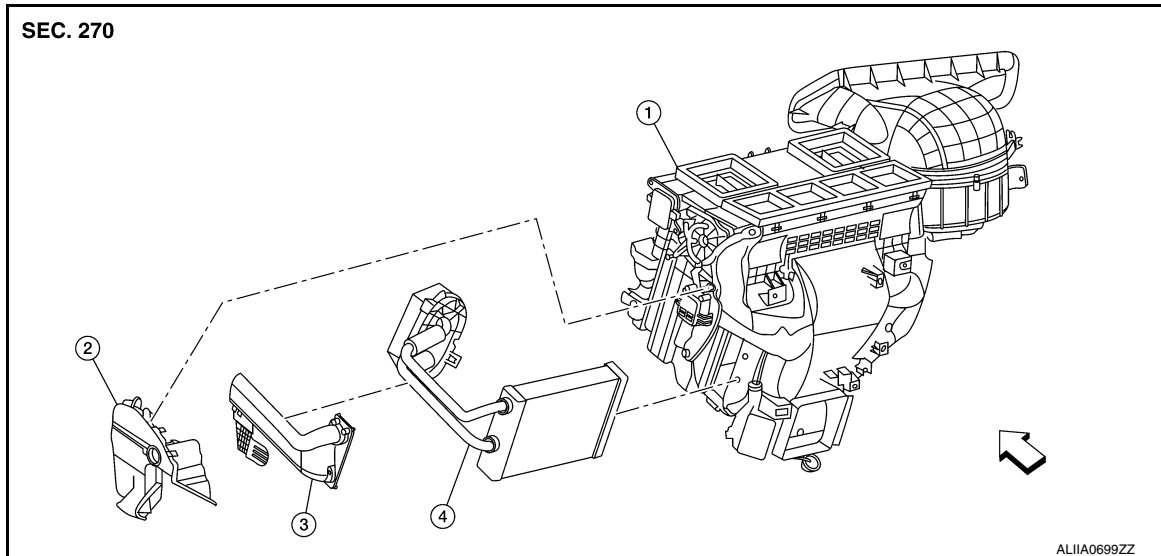

1. Front heating and cooling unit assembly
  2. Front foot duct (LH)
  3. Heater core pipes cover
  4. Heater core
- ← Front

## HEATER CORE : Removal and Installation

INFOID:000000012551295

### REMOVAL

#### NOTE:

When removing components such as hoses, lines/tubes, etc., cap or plug openings to prevent fluid from spilling.

1. Discharge the refrigerant. Refer to [HA-23, "Recycle Refrigerant"](#).
2. Drain the engine coolant. Refer to [CO-12, "Changing Engine Coolant"](#).
3. Remove the front heating and cooling unit assembly. Refer to [HA-42, "HEATING AND COOLING UNIT ASSEMBLY : Removal and Installation"](#).
4. Remove the front foot duct (LH). Refer to [HA-41, "HEATING AND COOLING UNIT ASSEMBLY : Exploded View"](#).
5. Remove the front heater core pipe cover. Refer to [HA-41, "HEATING AND COOLING UNIT ASSEMBLY : Exploded View"](#).
6. Remove the front heater core.

### INSTALLATION

Installation is in the reverse order of removal.

## EVAPORATOR

# HEATING AND COOLING UNIT ASSEMBLY

< REMOVAL AND INSTALLATION >

## EVAPORATOR : Exploded View

INFOID:000000012551296

Front Heating and Cooling Unit Components

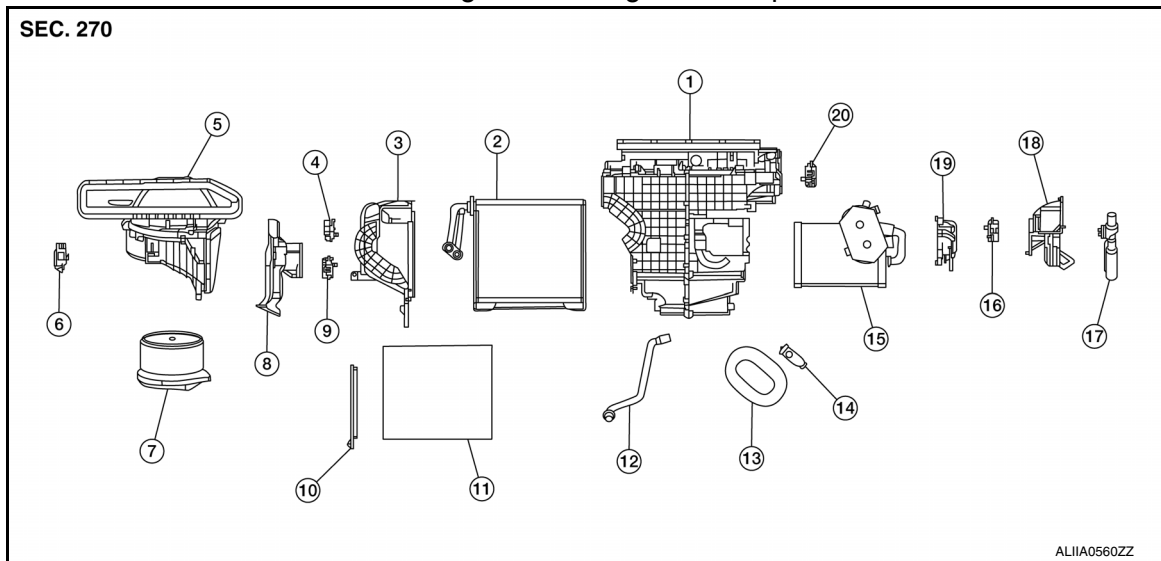

- |  |                                     |                                      |
|--|-------------------------------------|--------------------------------------|
| 1. Front heating and cooling unit assembly | 2. Front evaporator                 | 3. Heater case side cover            |
| 4. Air mix door motor (passenger side)     | 5. Front blower unit case           | 6. Intake door motor                 |
| 7. Front blower motor                      | 8. Upper floor connecting duct (RH) | 9. Air mix door motor (rear)         |
| 10. In-cabin microfilter cover             | 11. In-cabin microfilter            | 12. Drain hose                       |
| 13. Expansion valve grommet                | 14. Front expansion valve           | 15. Front heater core                |
| 16. Air mix door motor (driver side)       | 17. Aspirator hose                  | 18. Upper floor connecting duct (LH) |
| 19. Front heater core pipe cover           | 20. Mode door motor (front)         |                                      |

## EVAPORATOR : Removal and Installation

INFOID:000000012551297

### REMOVAL

1. Discharge the refrigerant. Refer to [HA-23, "Recycle Refrigerant"](#).
2. Remove the front heating and cooling unit assembly. Refer to [HA-41, "HEATING AND COOLING UNIT ASSEMBLY : Exploded View"](#).
3. Remove the front blower unit case from the front heating and cooling unit assembly.
4. Remove the heater case side cover.
5. Remove the front evaporator.  
**CAUTION:**  
**Cap or wrap the joint of the pipe with suitable material such as vinyl tape to avoid the entry of air.**
6. Remove the front expansion valve from the front evaporator (if necessary).

### INSTALLATION

Installation is in the reverse order of removal.

#### **CAUTION:**

- Do not reuse O-rings.
- Apply A/C oil to new O-rings for installation.
- After charging the refrigerant, check for leaks. Refer to [HA-21, "Leak Test"](#).

# HEATING AND COOLING UNIT ASSEMBLY

< REMOVAL AND INSTALLATION >

## EVAPORATOR : Exploded View

INFOID:000000012551298

Rear Heating and Cooling Unit Components

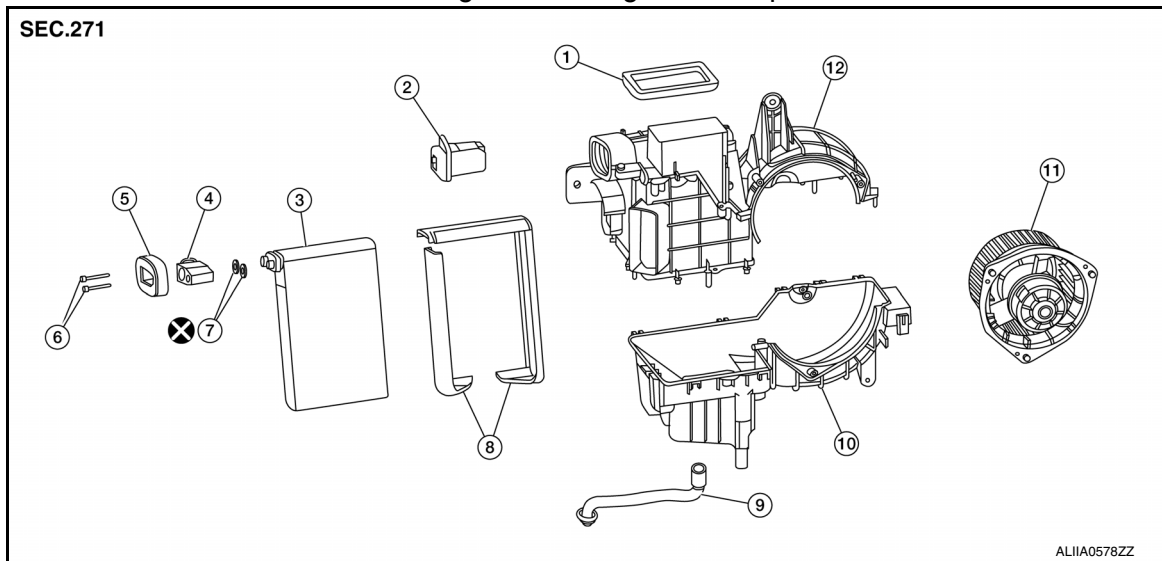

- |                                     |                                 |                                     |
|-------------------------------------|---------------------------------|-------------------------------------|
| 1. Rear ventilator duct upper seal  | 2. Rear blower motor resistor 2 | 3. Rear evaporator                  |
| 4. Rear expansion valve             | 5. Rear expansion valve grommet | 6. Rear expansion valve bolts       |
| 7. O-ring                           | 8. Rear evaporator seal         | 9. Rear drain hose                  |
| 10. Rear cooling unit lower housing | 11. Rear blower motor 2         | 12. Rear cooling unit upper housing |

## EVAPORATOR : Removal and Installation

INFOID:000000012551299

### REMOVAL

1. Discharge the refrigerant. Refer to [HA-23, "Recycle Refrigerant"](#).
2. Remove the rear cooling unit assembly. Refer to [HA-43, "HEATING AND COOLING UNIT ASSEMBLY : Removal and Installation"](#).
3. Separate the rear cooling unit upper and lower housing to access the rear evaporator.
4. Remove the rear evaporator.  
**CAUTION:**  
**Cap or wrap the joint of the pipe with suitable material such as vinyl tape to avoid the entry of air.**
5. Remove the rear expansion valve from the rear evaporator (if necessary).

### INSTALLATION

Installation is in the reverse order of removal.

#### **CAUTION:**

- Do not reuse O-rings.
- Apply A/C oil to the O-rings of the rear evaporator for installation.
- After charging the refrigerant, check for leaks. Refer to [HA-21, "Leak Test"](#).

### EXPANSION VALVE

# HEATING AND COOLING UNIT ASSEMBLY

< REMOVAL AND INSTALLATION >

## EXPANSION VALVE : Exploded View

INFOID:000000012551300

Front Heating and Cooling Unit Assembly Components

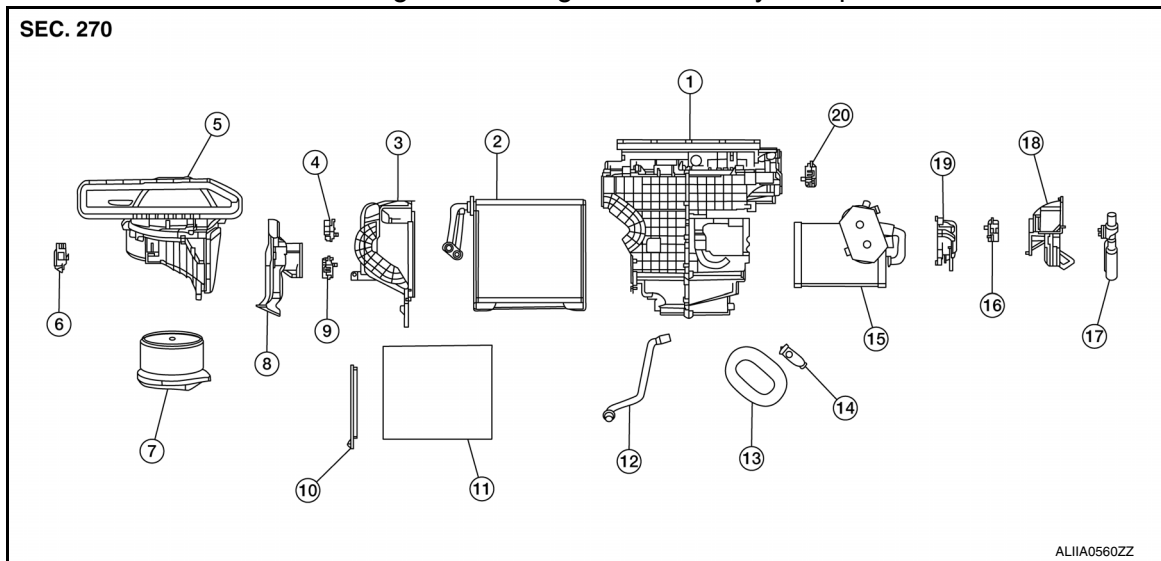

- |  |                                     |                                      |
|--|-------------------------------------|--------------------------------------|
| 1. Front heating and cooling unit assembly | 2. Front evaporator                 | 3. Heater case side cover            |
| 4. Air mix door motor (passenger side)     | 5. Front blower unit case           | 6. Intake door motor                 |
| 7. Front blower motor                      | 8. Upper floor connecting duct (RH) | 9. Air mix door motor (rear)         |
| 10. In-cabin microfilter cover             | 11. In-cabin microfilter            | 12. Drain hose                       |
| 13. Expansion valve grommet                | 14. Front expansion valve           | 15. Front heater core                |
| 16. Air mix door motor (driver side)       | 17. Aspirator hose                  | 18. Upper floor connecting duct (LH) |
| 19. Front heater core pipe cover           | 20. Mode door motor (front)         |                                      |

## EXPANSION VALVE : Removal and Installation

INFOID:000000012551301

### REMOVAL

1. Discharge the refrigerant. Refer to [HA-23, "Recycle Refrigerant"](#).
2. Remove the cowl top extension. Refer to [EXT-25, "Removal and Installation"](#).
3. Disconnect the high-pressure and low-pressure pipe from the expansion valve.  
**CAUTION:**  
**Cap or wrap the joint of the pipe with suitable material such as vinyl tape to avoid the entry of air.**
4. Remove the front expansion valve bolts, then remove the front expansion valve.  
**CAUTION:**  
**Cap or wrap the joint of the pipe with suitable material such as vinyl tape to avoid the entry of air.**

### INSTALLATION

Installation is in the reverse order of removal.

#### **CAUTION:**

- Do not reuse O-rings.
- Apply A/C oil to the O-rings of the front expansion valve for installation.
- After charging refrigerant, check for leaks. Refer to [HA-21, "Leak Test"](#).

# HEATING AND COOLING UNIT ASSEMBLY

< REMOVAL AND INSTALLATION >

## EXPANSION VALVE : Exploded View

INFOID:000000012551302

### Rear Heating and Cooling Unit Assembly Components

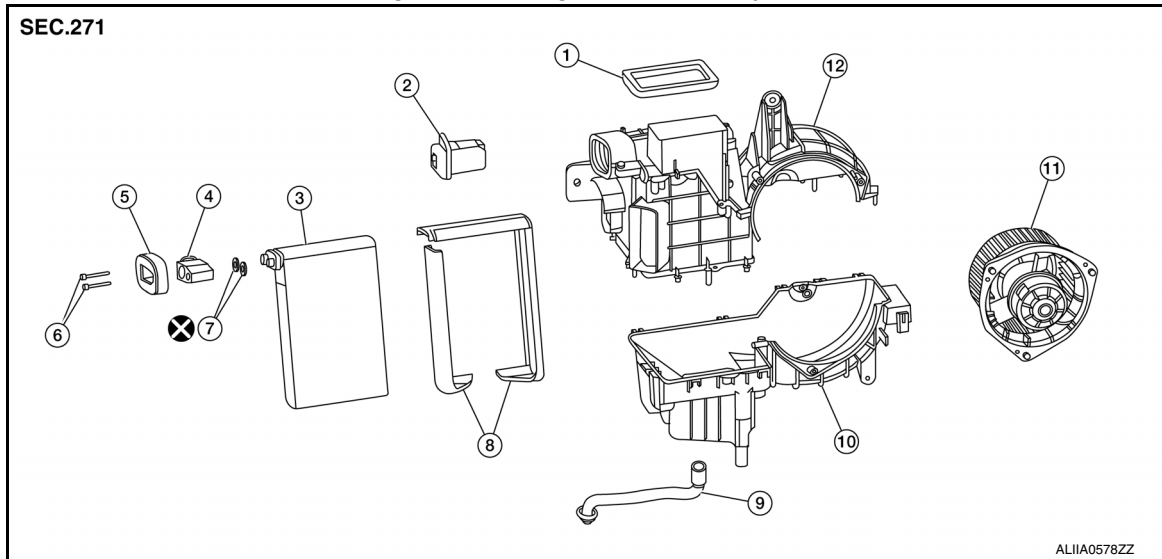

- |                                     |                                 |                                     |
|-------------------------------------|---------------------------------|-------------------------------------|
| 1. Rear ventilator duct upper seal  | 2. Rear blower motor resistor 2 | 3. Rear evaporator                  |
| 4. Rear expansion valve             | 5. Rear expansion valve grommet | 6. Rear expansion valve bolts       |
| 7. O-ring                           | 8. Rear evaporator seal         | 9. Rear drain hose                  |
| 10. Rear cooling unit lower housing | 11. Rear blower motor 2         | 12. Rear cooling unit upper housing |

## EXPANSION VALVE : Removal and Installation

INFOID:000000012551303

### REMOVAL

1. Discharge the refrigerant. Refer to [HA-23, "Recycle Refrigerant"](#).
2. Remove the luggage side lower finisher (RH). Refer to [INT-31, "LUGGAGE SIDE LOWER FINISHER : Removal and Installation"](#).
3. Disconnect the rear underfloor high-pressure and low-pressure pipes from the rear cooling unit assembly.  
**CAUTION:**  
**Cap or wrap the joint of the pipe with suitable material such as vinyl tape to avoid the entry of air.**
4. Remove the rear expansion valve bolts, then remove the rear expansion valve.  
**CAUTION:**  
**Cap or wrap the joint of the pipe with suitable material such as vinyl tape to avoid the entry of air.**

### INSTALLATION

Installation is in the reverse order of removal.

#### **CAUTION:**

- Do not reuse O-rings.
- Apply A/C oil to the O-rings of the rear expansion valve for installation.
- After charging refrigerant, check for leaks. Refer to [HA-21, "Leak Test"](#).



# PTC HEATER

< REMOVAL AND INSTALLATION >

## PTC HEATER

### Exploded View

INFOID:000000012551304

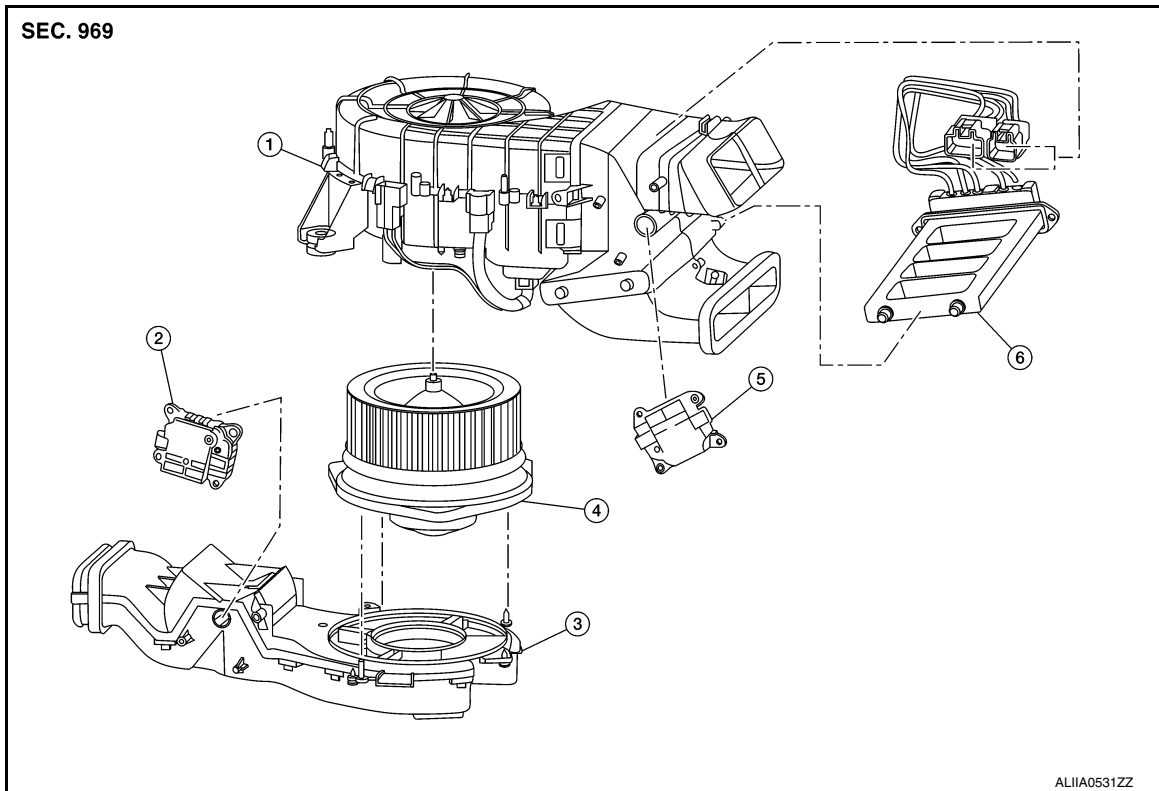

- |  |                             |  |
|--|-----------------------------|--|
| 1. Rear blower motor 1 unit assembly upper housing | 2. Rear shut-off door motor | 3. Rear blower motor 1 unit assembly lower housing |
| 4. Rear blower motor 1                             | 5. Mode door motor (rear)   | 6. PTC heater                                      |

### Removal and Installation

INFOID:000000012551305

#### REMOVAL

1. Remove the rear blower motor 1 unit assembly. Refer to [VTL-20. "REAR BLOWER MOTOR 1 UNIT ASSEMBLY : Removal and Installation"](#).
2. Disconnect the harness connectors from the PTC heater.
3. Remove the PTC heater screws, then remove the PTC heater.

#### INSTALLATION

Installation is in the reverse order of removal.

## SERVICE DATA AND SPECIFICATIONS (SDS)

< SERVICE DATA AND SPECIFICATIONS (SDS)

# SERVICE DATA AND SPECIFICATIONS (SDS)

## SERVICE DATA AND SPECIFICATIONS (SDS)

### Compressor

INFOID:0000000012551306

Model	DCS-171C	
Type	Variable displacement swash plate	
Displacement	171 cm <sup>3</sup> (10.4 cu in)/rev	
Number of cylinders	7	
Cylinder bore diameter × stroke mm (in)	32 x 30.5 mm (1.3 x 1.2 in)	
Direction of rotation	Clockwise (viewed from clutch)	
Drive belt	Poly V 7 grooves	
Disc to pulley clearance mm (in)	Standard	0.3 – 0.6 mm (0.012 – 0.024 in)

### Oil

INFOID:0000000012551307

Name	A/C System Oil Type S (DH-PS)	
Capacity mℓ (US fl oz, Imp fl oz)	Total in system	230 (7.8, 8.1)
	Compressor (service part) charging amount	Refer to <a href="#">HA-26, "Oil Adjusting Procedure for Compressor Replacement"</a> .

### Refrigerant

INFOID:0000000012551308

Type	HFC-134a (R-134a)
Capacity	0.80 ± 0.03 kg (1.80 ± 0.07 lb)