

CONTENTS

PRECAUTIONS	2	Circuit Inspection	26
Supplemental Restraint System (SRS) "AIR BAG" and "SEAT BELT PRE-TENSIONER"	2	HOW TO FOLLOW FLOW CHART IN TROUBLE	
Precautions for IPPS (Infiniti Personal Protection System — NATS)	2	DIAGNOSES	32
General Precautions	3	CONSULT CHECKING SYSTEM	35
Precautions for Multiport Fuel Injection System or ECCS Engine	5	Function and System Application	35
Precautions for Three Way Catalyst	5	Lithium Battery Replacement	35
Engine Oils	5	Checking Equipment	35
Precautions for Fuel	6	IDENTIFICATION INFORMATION	36
Precautions for Air Conditioning	6	Model Variation	36
HOW TO USE THIS MANUAL	7	Identification Number	37
HOW TO READ WIRING DIAGRAMS	9	Dimensions	38
Sample/Wiring Diagram — EXAMPL —	9	Wheels and Tires	38
Description	11	LIFTING POINTS AND TOW TRUCK TOWING	39
Wiring Diagram Codes (Cell Codes)	19	Preparation	39
HOW TO PERFORM EFFICIENT DIAGNOSIS FOR AN ELECTRICAL INCIDENT	21	Board-on Lift	39
Work Flow	21	Garage Jack and Safety Stand	40
Incident Simulation Tests	22	2-pole Lift	41
		Tow Truck Towing	41
		TIGHTENING TORQUE OF STANDARD BOLTS	43
		SAE J1930 TERMINOLOGY LIST	44
		SAE J1930 Terminology List	44

PRECAUTIONS

Observe the following precautions to ensure safe and proper servicing.

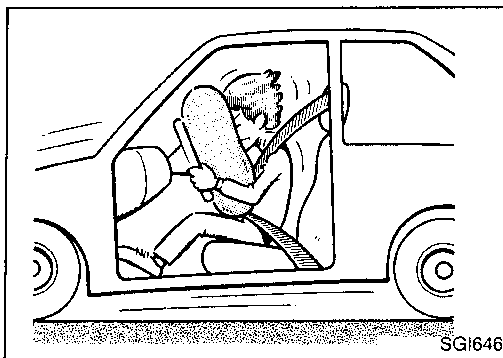

Supplemental Restraint System (SRS) “AIR BAG” and “SEAT BELT PRE-TENSIONER”

The Supplemental Restraint System “Air Bag” and “Seat Belt Pre-tensioner”, used along with a seat belt, help to reduce the risk or severity of injury to the driver and front passenger in a frontal collision. The Supplemental Restraint System consists of air bag modules (located in the center of the steering wheel and on the instrument panel on the passenger side), seat belt pre-tensioners, a diagnosis sensor unit, warning lamp, wiring harness and spiral cable. Information necessary to service the system safely is included in the **RS** section in this Service Manual.

WARNING:

- To avoid rendering the SRS inoperative, which could increase the risk of personal injury or death in the event of a collision which would result in air bag inflation, all maintenance must be performed by an authorized INFINITI dealer.
- Improper maintenance, including incorrect removal and installation of the SRS, can lead to personal injury caused by unintentional activation of the system.
- Do not use electrical test equipment on any circuit related to the SRS unless instructed to in this Service Manual. SRS wiring harnesses are covered with yellow insulation either just before the harness connectors or for the complete harness, for easy identification.

Precautions for IPPS (Infiniti Personal Protection System — NATS)

NATS (Nissan Anti-Theft System)

NATS will immobilize the engine if someone tries to start it without the registered key of NATS.

Both of the originally supplied ignition key IDs have been NATS registered.

The security indicator is located on the instrument panel. The indicator blinks when the ignition switch is in “OFF” or “ACC” position. Therefore, NATS warns outsiders that the vehicle is equipped with the anti-theft system.

- When NATS detects trouble, the security indicator lamp lights up while ignition switch is in “ON” position. This lighting up indicates that the anti-theft is not functioning, so prompt service is required.

PRECAUTIONS

Precautions for IPPS (Infiniti Personal Protection System — NATS) (Cont'd)

- When servicing NATS (trouble diagnoses, system initialisation and additional registration of other NATS ignition key IDs), CONSULT hardware and CONSULT NATS software is necessary.
Regarding the procedures of NATS initialisation and NATS ignition key ID registration, refer to CONSULT operation manual, NATS.

Therefore, CONSULT NATS software (program card and operation manual) must be kept strictly confidential to maintain the integrity of the anti-theft function.

- When servicing NATS (trouble diagnoses, system initialisation and additional registration of other NATS ignition key IDs), it may be necessary to re-register original key identification. Therefore, be sure to receive all keys from vehicle owner. A maximum of five key IDs can be registered into NATS.
- When failing to start the engine first time using the key of NATS, start as follows.
 - (1) Leave the ignition key in "ON" position for approximately 5 seconds.
 - (2) Turn ignition key to "OFF".
 - (3) Wait approximately 5 seconds.
 - (4) Turn ignition key to "START" again while keeping the key apart from any others on key-chain.

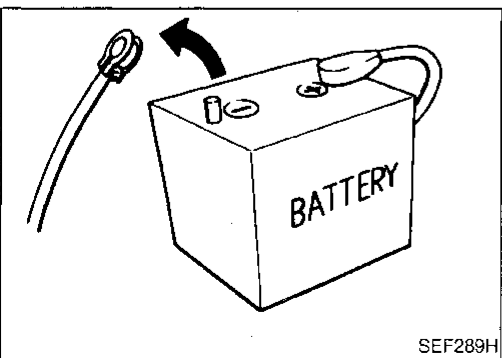
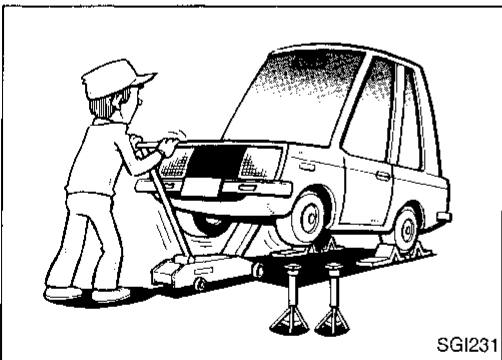
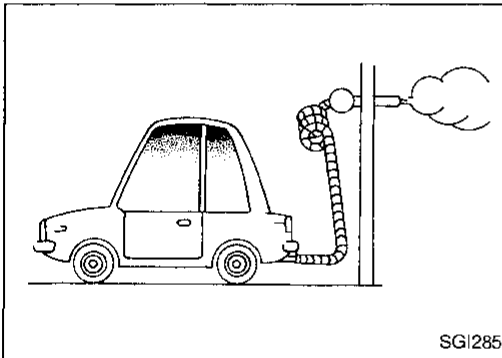

General Precautions

- Do not operate the engine for an extended period of time without proper exhaust ventilation.
Keep the work area well ventilated and free of any inflammable materials. Special care should be taken when handling any inflammable or poisonous materials, such as gasoline, refrigerant gas, etc. When working in a pit or other enclosed area, be sure to properly ventilate the area before working with hazardous materials.
Do not smoke while working on the vehicle.

- Before jacking up the vehicle, apply wheel chocks or other tire blocks to the wheels to prevent the vehicle from moving. After jacking up the vehicle, support the vehicle weight with safety stands at the points designated for proper lifting and towing before working on the vehicle.
These operations should be done on a level surface.
- When removing a heavy component such as the engine or transaxle/transmission, be careful not to lose your balance and drop them. Also, do not allow them to strike adjacent parts, especially the brake tubes and master cylinder.
- Before starting repairs which do not require battery power:
Turn off ignition switch.
Disconnect the negative battery terminal.

PRECAUTIONS

General Precautions (Cont'd)

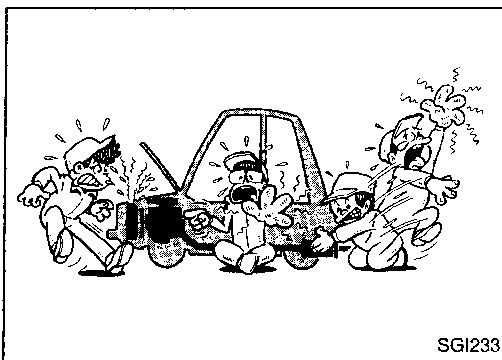

- To prevent serious burns:
Avoid contact with hot metal parts.
Do not remove the radiator cap when the engine is hot.

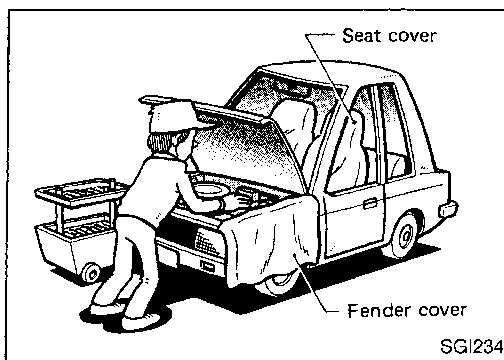

- Before servicing the vehicle:
Protect fenders, upholstery and carpeting with appropriate covers.
Take caution that keys, buckles or buttons do not scratch paint.

- Clean all disassembled parts in the designated liquid or solvent prior to inspection or assembly.
- Replace oil seals, gaskets, packings, O-rings, locking washers, cotter pins, self-locking nuts, etc. with new ones.
- Replace inner and outer races of tapered roller bearings and needle bearings as a set.
- Arrange the disassembled parts in accordance with their assembled locations and sequence.
- Do not touch the terminals of electrical components which use microcomputers (such as ECMs).
Static electricity may damage internal electronic components.
- After disconnecting vacuum or air hoses, attach a tag to indicate the proper connection.
- Use only the lubricants specified in this manual.
- Use approved bonding agent, sealants or their equivalents when required.
- Use tools and recommended special tools where specified for safe and efficient service repairs.
- When repairing the fuel, oil, water, vacuum or exhaust systems, check all affected lines for leaks.
- Dispose of drained oil or the solvent used for cleaning parts in an appropriate manner.

WARNING:

To prevent ECM from storing the diagnostic trouble codes, do not carelessly disconnect the harness connectors which are related to the ECCS system and A/T control system. The connectors should be disconnected only when working according to the WORK FLOW of TROUBLE DIAGNOSES in EC and AT sections.

PRECAUTIONS

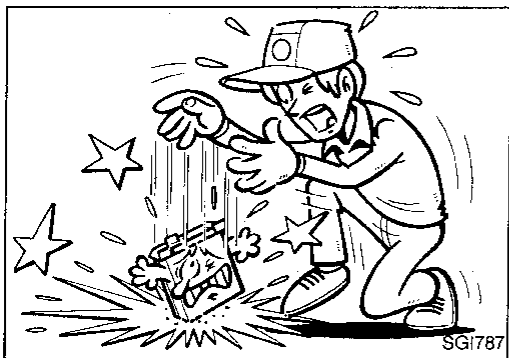

Precautions for Multiport Fuel Injection System or ECCS Engine

- Before connecting or disconnecting any harness connector for the multiport fuel injection system or ECM (ECCS control module):
Turn ignition switch to "OFF" position.
Disconnect negative battery terminal.
Otherwise, there may be damage to ECM.
- Before disconnecting pressurized fuel line from fuel pump to injectors, be sure to release fuel pressure.
- Be careful not to jar components such as ECM and mass air flow sensor.

GI

MA

EM

LC

Precautions for Three Way Catalyst

If a large amount of unburned fuel flows into the catalyst, the catalyst temperature will be excessively high. To prevent this, follow the instructions below:

- Use unleaded gasoline only. Leaded gasoline will seriously damage the three way catalyst.
- When checking for ignition spark or measuring engine compression, make tests quickly and only when necessary.
- Do not run engine when the fuel tank level is low, otherwise the engine may misfire causing damage to the catalyst.

Do not place the vehicle on inflammable material. Keep inflammable material off the exhaust pipe and the three way catalyst.

EC

FE

AT

PD

Engine Oils

Prolonged and repeated contact with used engine oil may cause skin cancer. Try to avoid direct skin contact with used oil.

If skin contact is made, wash thoroughly with soap or hand cleaner as soon as possible.

FA

RA

HEALTH PROTECTION PRECAUTIONS

- Avoid prolonged and repeated contact with oils, particularly used engine oils.
- Wear protective clothing, including impervious gloves where practicable.
- Do not put oily rags in pockets.
- Avoid contaminating clothes, particularly underpants, with oil.
- Heavily soiled clothing and oil-impregnated footwear should not be worn. Overalls must be cleaned regularly.
- First Aid treatment should be obtained immediately for open cuts and wounds.
- Use barrier creams, applying them before each work period, to help the removal of oil from the skin.
- Wash with soap and water to ensure all oil is removed (skin cleansers and nail brushes will help). Preparations containing lanolin replace the natural skin oils which have been removed.
- Do not use gasoline, kerosine, diesel fuel, gas oil, thinners or solvents for cleaning skin.
- If skin disorders develop, obtain medical advice without delay.
- Where practicable, degrease components prior to handling.
- Where there is a risk of eye contact, eye protection should be worn, for example, chemical goggles or face shields; in addition an eye wash facility should be provided.

BR

ST

RS

BT

HA

EL

IDX

PRECAUTIONS

Engine Oils (Cont'd)

ENVIRONMENTAL PROTECTION PRECAUTIONS

Burning used engine oil in small space heaters or boilers can be recommended only for units of approved design. The heating system must meet the requirements of HM Inspectorate of Pollution for small burners of less than 0.4 MW. If in doubt check with the appropriate local authority and/or manufacturer of the approved appliance.

Dispose of used oil and used oil filters through authorized waste disposal contractors to licensed waste disposal sites, or to the waste oil reclamation trade. If in doubt, contact the local authority for advice on disposal facilities.

It is illegal to pour used oil on to the ground, down sewers or drains, or into water courses.

The regulations concerning the pollution of the environment will vary between regions.

Precautions for Fuel

Use premium unleaded gasoline with an octane rating of at least 91 AKI (Anti-Knock Index) number (research octane number 96). If premium unleaded gasoline is not available, regular unleaded gasoline with an octane rating of at least 87 AKI (research octane number 91) can be used.

However, for maximum vehicle performance, the use of premium unleaded gasoline is recommended.

CAUTION:

Do not use leaded gasoline. Using leaded gasoline will damage the three way catalyst.

Using a fuel other than that specified could adversely affect the emission control devices and systems, and could also affect the warranty coverage validity.

Precautions for Air Conditioning

Use an approved refrigerant recovery unit any time the air conditioning system must be discharged. Refer to HA section ("HFC-134a (R-134a) Service Procedure", "SERVICE PROCEDURES") for specific instructions.

HOW TO USE THIS MANUAL

- **ALPHABETICAL INDEX** is provided at the end of this manual so that you can rapidly find the item and page you are searching for.
 - **A QUICK REFERENCE INDEX**, a black tab (e.g. **BR**) is provided on the first page. You can quickly find the first page of each section by mating it to the section's black tab.
 - **THE CONTENTS** are listed on the first page of each section.
 - **THE TITLE** is indicated on the upper portion of each page and shows the part or system.
 - **THE PAGE NUMBER** of each section consists of two letters which designate the particular section and a number (e.g. "BR-5").
 - **THE LARGE ILLUSTRATIONS** are exploded views (See below) and contain tightening torques, lubrication points, section number of the **PARTS CATALOG** (e.g. SEC.440) and other information necessary to perform repairs.
- The illustrations should be used in reference to service matters only. When ordering parts, refer to the appropriate **PARTS CATALOG**.

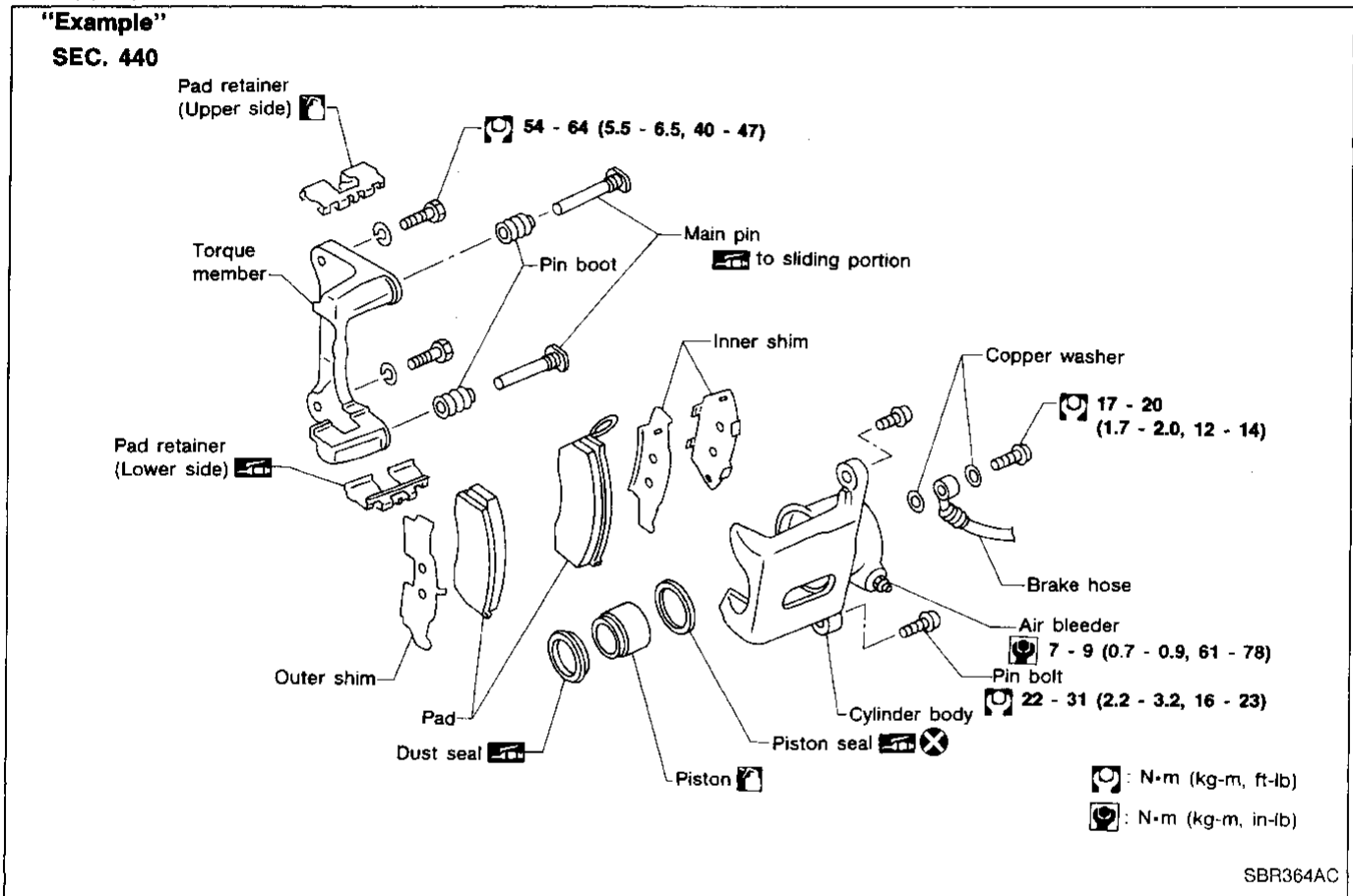









- **THE SMALL ILLUSTRATIONS** show the important steps such as inspection, use of special tools, knacks of work and hidden or tricky steps which are not shown in the previous large illustrations. Assembly, inspection and adjustment procedures for the complicated units such as the automatic transaxle or transmission, etc. are presented in a step-by-step format where necessary.

GI
 MA
 EM
 LC
 EC
 FE
 AT
 PD
 FA
 RA
 BR
 ST
 RS
 BT
 HA
 EL
 IDX

HOW TO USE THIS MANUAL

- The following **SYMBOLS AND ABBREVIATIONS** are used:

	: Tightening torque	A/T	: Automatic Transaxle/Transmission
	: Should be lubricated with grease. Unless otherwise indicated, use recommended multi-purpose grease.	A/C	: Air Conditioner
	: Should be lubricated with oil.	P/S	: Power Steering
	: Sealing point	SST	: Special Service Tools
	: Checking point	SDS	: Service Data and Specifications
	: Always replace after every disassembly.	SAE	: Society of Automotive Engineers, Inc.
LH, RH	: Left-Hand, Right-Hand	LHD	: Left-Hand Drive
FR, RR	: Front, Rear	RHD	: Right-Hand Drive
2WD	: 2-Wheel Drive	ATF	: Automatic Transmission Fluid
 (P)	: Apply petroleum jelly.	D ₁	: Drive range 1st gear
 (ATF)	: Apply ATF.	D ₂	: Drive range 2nd gear
★	: Select with proper thickness.	D ₃	: Drive range 3rd gear
☆	: Adjustment is required.	D ₄	: Drive range 4th gear
M/T	: Manual Transaxle/Transmission	OD	: Overdrive
		2 ₂	: 2nd range 2nd gear
		2 ₁	: 2nd range 1st gear
		1 ₂	: 1st range 2nd gear
		1 ₁	: 1st range 1st gear

- The **UNITS** given in this manual are primarily expressed as SI UNITS (International System of Unit), and alternatively expressed in the metric system and in the yard/pound system.

“Example”

Tightening torque:

59 - 78 N·m (6.0 - 8.0 kg-m, 43 - 58 ft-lb)

- TROUBLE DIAGNOSES** are included in sections dealing with complicated components.
- SERVICE DATA AND SPECIFICATIONS** are contained at the end of each section for quick reference of data.
- The captions **WARNING** and **CAUTION** warn you of steps that must be followed to prevent personal injury and/or damage to some part of the vehicle.

WARNING indicates the possibility of personal injury if instructions are not followed.

CAUTION indicates the possibility of component damage if instructions are not followed.

BOLD TYPED STATEMENTS except **WARNING** and **CAUTION** give you helpful information.

HOW TO READ WIRING DIAGRAMS

Sample/Wiring Diagram — EXAMPL —

- For Description, refer to GI-11.

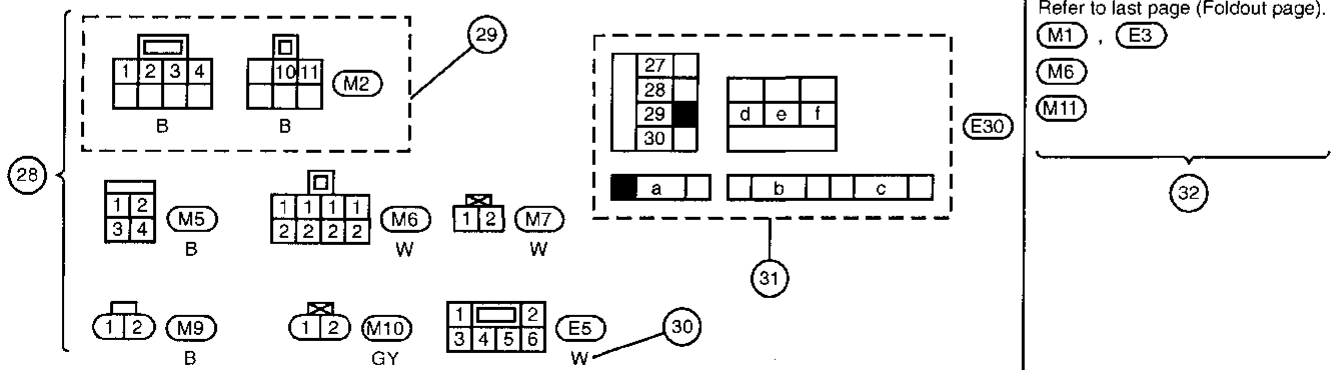
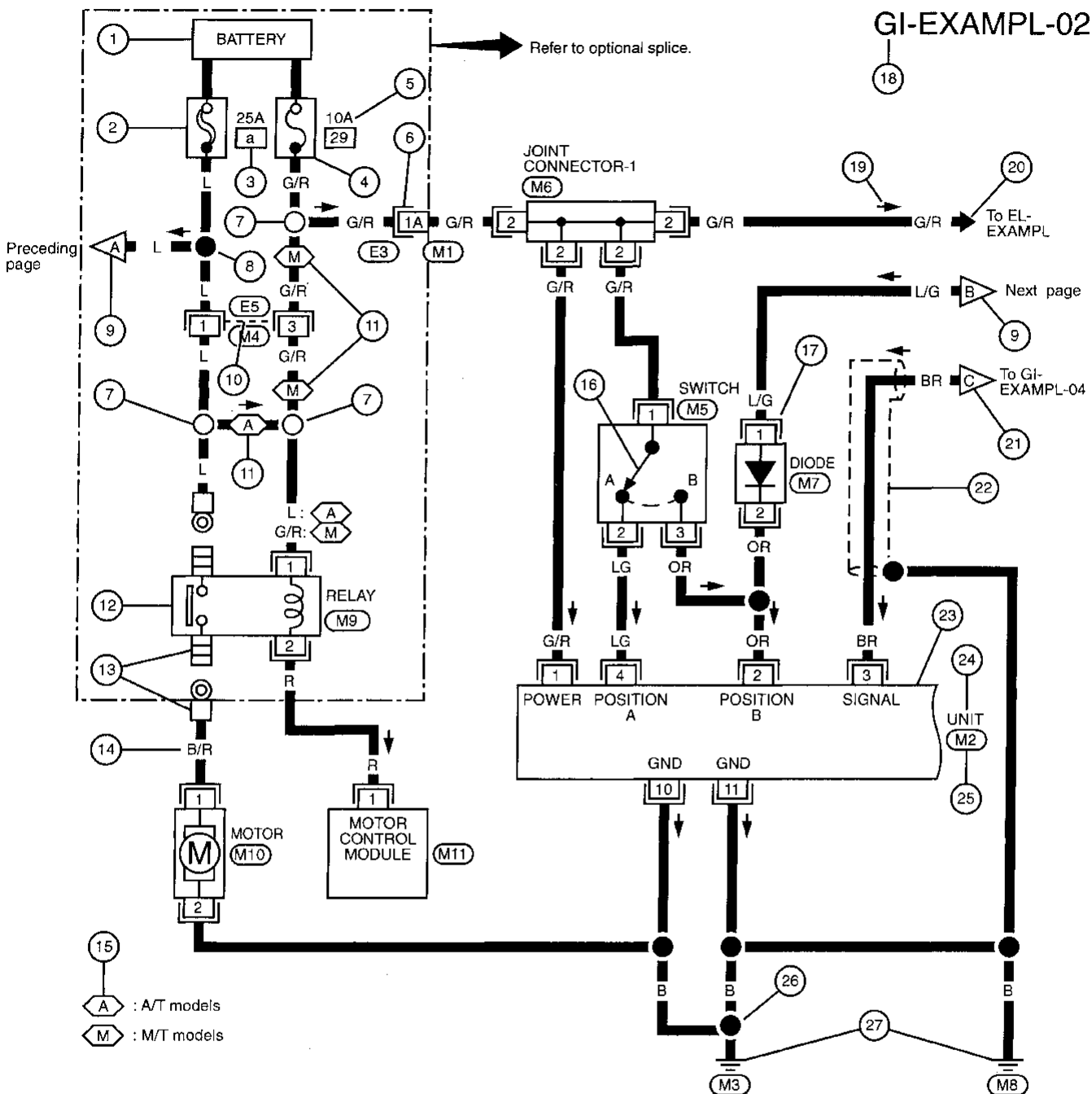

GI
MA
EM
LC
EC
FE
AT
PD
FA
RA
BR
ST
RS
BT
HA
EL
IDX

HOW TO READ WIRING DIAGRAMS

Sample/Wiring Diagram — EXAMPL — (Cont'd) OPTIONAL SPLICE

Optional splice

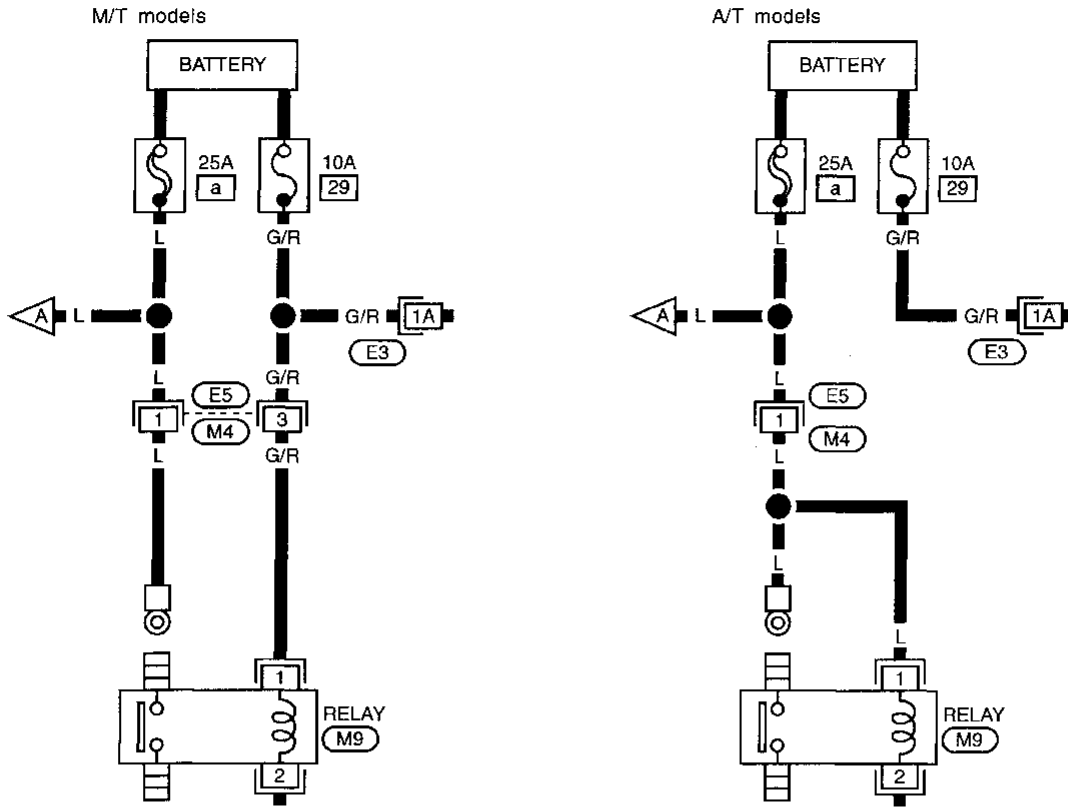

SGI942

HOW TO READ WIRING DIAGRAMS

Description

Number	Item	Description																
①	Power condition	<ul style="list-style-type: none"> This shows the condition when the system receives battery positive voltage (can be operated). 																
②	Fusible link	<ul style="list-style-type: none"> The double line shows that this is a fusible link. The open circle shows current flow in, and the shaded circle shows current flow out. 																
③	Fusible link/fuse location	<ul style="list-style-type: none"> This shows the location of the fusible link or fuse in the fusible link or fuse box. For arrangement, refer to EL section ("POWER SUPPLY ROUTING"). 																
④	Fuse	<ul style="list-style-type: none"> The single line shows that this is a fuse. The open circle shows current flow in, and the shaded circle shows current flow out. 																
⑤	Current rating	<ul style="list-style-type: none"> This shows the current rating of the fusible link or fuse. 																
⑥	Connectors	<ul style="list-style-type: none"> This shows that connector (E9) is female and connector (M1) is male. The G/R wire is located in the 1A terminal of both connectors. Terminal number with an alphabet (1A, 5B, etc.) indicates that the connector is SMJ connector. Refer to GI-17. 																
⑦	Optional splice	<ul style="list-style-type: none"> The open circle shows that the splice is optional depending on vehicle application. 																
⑧	Splice	<ul style="list-style-type: none"> The shaded circle shows that the splice is always on the vehicle. 																
⑨	Page crossing	<ul style="list-style-type: none"> This arrow shows that the circuit continues to an adjacent page. The A will match with the A on the preceding or next page. 																
⑩	Common connector	<ul style="list-style-type: none"> The dotted lines between terminals show that these terminals are part of the same connector. 																
⑪	Option abbreviation	<ul style="list-style-type: none"> This shows that the circuit is optional depending on vehicle application. 																
⑫	Relay	<ul style="list-style-type: none"> This shows an internal representation of the relay. For details, refer to EL section ("STANDARDIZED RELAY"). 																
⑬	Connectors	<ul style="list-style-type: none"> This shows that the connector is connected to the body or a terminal with bolt or nut. 																
⑭	Wire color	<ul style="list-style-type: none"> This shows a code for the color of the wire. <table border="0"> <tr> <td>B = Black</td> <td>BR = Brown</td> </tr> <tr> <td>W = White</td> <td>OR = Orange</td> </tr> <tr> <td>R = Red</td> <td>P = Pink</td> </tr> <tr> <td>G = Green</td> <td>PU = Purple</td> </tr> <tr> <td>L = Blue</td> <td>GY = Gray</td> </tr> <tr> <td>Y = Yellow</td> <td>SB = Sky Blue</td> </tr> <tr> <td>LG = Light Green</td> <td>CH = Dark Brown</td> </tr> <tr> <td></td> <td>DG = Dark Green</td> </tr> </table> <p>When the wire color is striped, the base color is given first, followed by the stripe color as shown below: Example: L/W = Blue with White Stripe</p>	B = Black	BR = Brown	W = White	OR = Orange	R = Red	P = Pink	G = Green	PU = Purple	L = Blue	GY = Gray	Y = Yellow	SB = Sky Blue	LG = Light Green	CH = Dark Brown		DG = Dark Green
B = Black	BR = Brown																	
W = White	OR = Orange																	
R = Red	P = Pink																	
G = Green	PU = Purple																	
L = Blue	GY = Gray																	
Y = Yellow	SB = Sky Blue																	
LG = Light Green	CH = Dark Brown																	
	DG = Dark Green																	
⑮	Option description	<ul style="list-style-type: none"> This shows a description of the option abbreviation used on the page. 																
⑯	Switch	<ul style="list-style-type: none"> This shows that continuity exists between terminals 1 and 2 when the switch is in the A position. Continuity exists between terminals 1 and 3 when the switch is in the B position. 																
⑰	Assembly parts	<ul style="list-style-type: none"> Connector terminal in component shows that it is a harness incorporated assembly. 																
⑱	Cell code	<ul style="list-style-type: none"> This identifies each page of the wiring diagram by section, system and wiring diagram page number. 																
⑲	Current flow arrow	<ul style="list-style-type: none"> Arrow indicates electric current flow, especially where the direction of standard flow (vertically downward or horizontally from left to right) is difficult to follow. A double arrow "↔" shows that current can flow in either direction depending on circuit operation. 																

HOW TO READ WIRING DIAGRAMS



Description (Cont'd)

Number	Item	Description
⑳	System branch	<ul style="list-style-type: none"> This shows that the system branches to another system identified by cell code (section and system).
㉑	Page crossing	<ul style="list-style-type: none"> This arrow shows that the circuit continues to another page identified by cell code. The C will match with the C on another page within the system other than the next or preceding pages.
㉒	Shielded line	<ul style="list-style-type: none"> The line enclosed by broken line circle shows shield wire.
㉓	Component box in wave line	<ul style="list-style-type: none"> This shows that another part of the component is also shown on another page (indicated by wave line) within the system.
㉔	Component name	<ul style="list-style-type: none"> This shows the name of a component.
㉕	Connector number	<ul style="list-style-type: none"> This shows the connector number. The letter shows which harness the connector is located in. Example: M: main harness. For detail and to locate the connector, refer to EL section ("Main Harness", "HARNESS LAYOUT"). A coordinate grid is included for complex harnesses to aid in locating connectors.
㉖	Ground (GND)	<ul style="list-style-type: none"> The line spliced and grounded under wire color shows that ground line is spliced at the grounded connector.
㉗	Ground (GND)	<ul style="list-style-type: none"> This shows the ground connection.
㉘	Connector views	<ul style="list-style-type: none"> This area shows the connector faces of the components in the wiring diagram on the page.
㉙	Common component	<ul style="list-style-type: none"> Connectors enclosed in broken line show that these connectors belong to the same component.
㉚	Connector color	<ul style="list-style-type: none"> This shows a code for the color of the connector. For code meaning, refer to wire color codes, Number ⑭ of this chart.
㉛	Fusible link and fuse box	<ul style="list-style-type: none"> This shows the arrangement of fusible link(s) and fuse(s), used for connector views of "POWER SUPPLY ROUTING" in EL section. The open square shows current flow in, and the shaded square shows current flow out.
㉜	Reference area	<ul style="list-style-type: none"> This shows that more information on the Super Multiple Junction (SMJ) and Joint Connectors (J/C) exists on the foldout page. Refer to GI-17 for details.

HOW TO READ WIRING DIAGRAMS

Description (Cont'd) CONNECTOR SYMBOLS

Most of connector symbols in wiring diagrams are shown from the terminal side.

- Connector symbols shown from the terminal side are enclosed by a single line and followed by the direction mark  .
- Connector symbols shown from the harness side are enclosed by a double line and followed by the direction mark  .

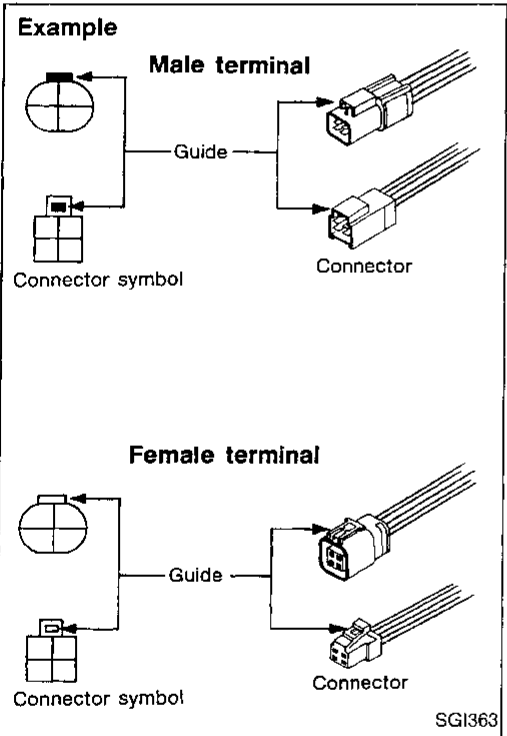
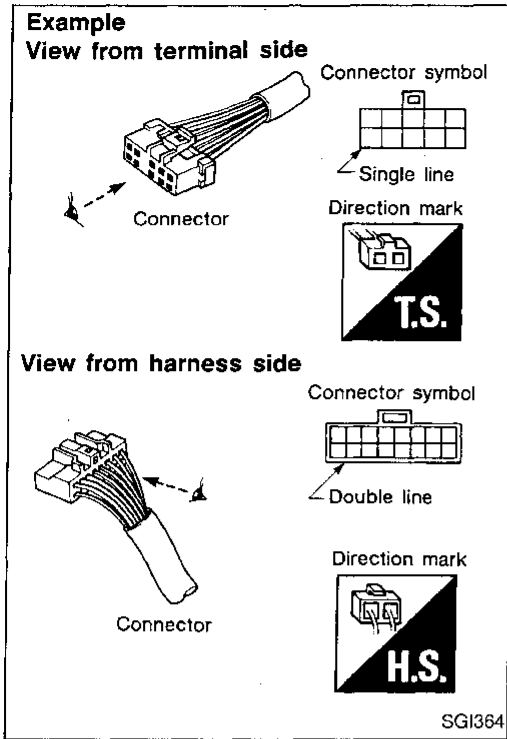

- Male and female terminals
Connector guides for male terminals are shown in black and female terminals in white in wiring diagrams.

GI
MA
EM
LC
EC
FE
AT
PD
FA
RA
BR
ST
RS
BT
HA
EL
IDX

HOW TO READ WIRING DIAGRAMS

Description (Cont'd)

- Connector numbers that indicate harness are enclosed by a single line.
- Connector numbers that indicate components are enclosed by a double line.

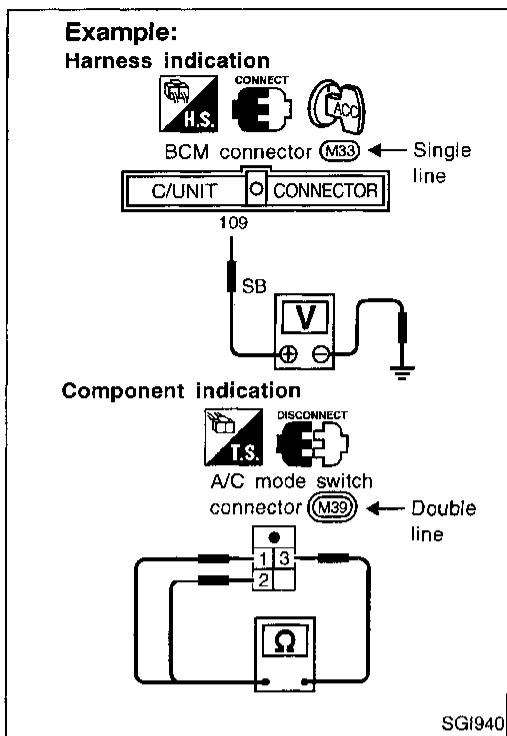

SWITCH POSITIONS

Switches are shown in wiring diagrams as if the vehicle is in the "normal" condition.

A vehicle is in the "normal" condition when:

- ignition switch is "OFF",
- doors, hood and trunk lid/back door are closed,
- pedals are not depressed, and
- parking brake is released.

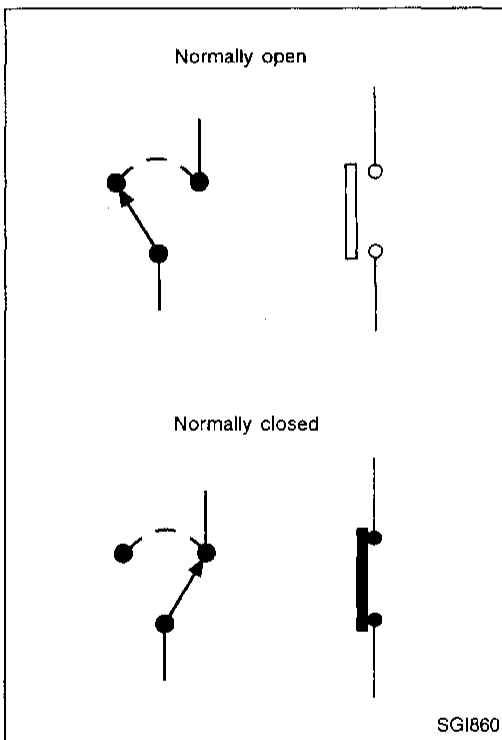

HOW TO READ WIRING DIAGRAMS

Description (Cont'd)

DETECTABLE LINES AND NON-DETECTABLE LINES

In some wiring diagrams, two kinds of lines, representing wires, with different weight are used.

- A line with regular weight (wider line) represents a "detectable line for DTC (Diagnostic Trouble Code)". A "detectable line for DTC" is a circuit in which ECM (ECCS control module) can detect its malfunctions with the on-board diagnostic system.
- A line with less weight (thinner line) represents a "non-detectable line for DTC". A "non-detectable line for DTC" is a circuit in which ECM cannot detect its malfunctions with the on-board diagnostic system.

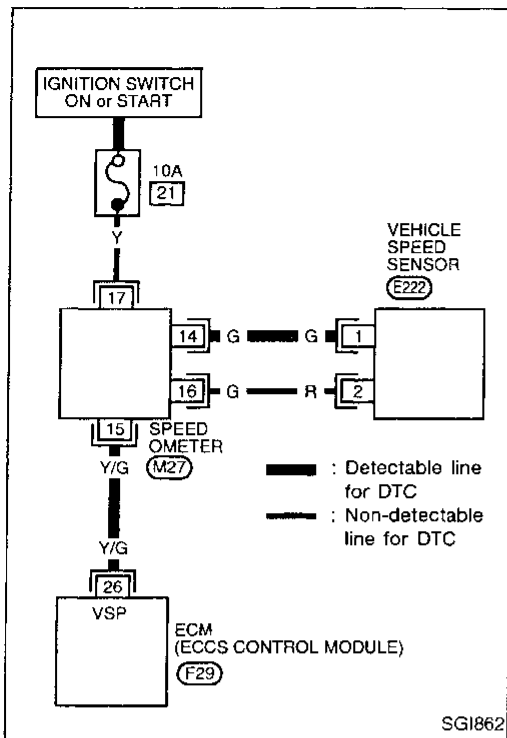

GI
MA
EM
LC
EC
FE
AT
PD
FA
RA
BR
ST
RS
BT
HA
EL
IDX

HOW TO READ WIRING DIAGRAMS

Description (Cont'd)

MULTIPLE SWITCH

The continuity of multiple switch is described in two ways as shown below.

- The switch chart is used in schematic diagrams.
- The switch diagram is used in wiring diagrams.

Example

(SWITCH CHART)

WIPER SWITCH

	OFF	INT	LO	HI	WASH
1					○
2				○	
3	○	○	○	○	
4	○	○	○	○	
5		○	○	○	
6		○	○	○	○

(SWITCH DIAGRAM)

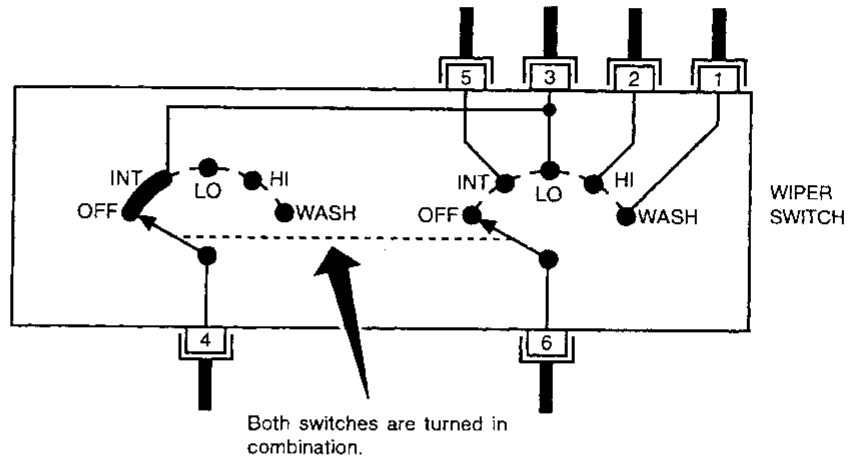

Continuity circuit of wiper switch

SWITCH POSITION	CONTINUITY CIRCUIT
OFF	3-4
INT	3-4, 5-6
LO	3-6
HI	2-6
WASH	1-6

SGI875

HOW TO READ WIRING DIAGRAMS

Description (Cont'd)

FOLDOUT PAGE

The foldout page should be opened when reading wiring diagram.

Super multiple junction (SMJ)

In wiring diagram, connectors consisting of terminals having terminal numbers with an alphabet (1B, 0D, etc.) are SMJ connectors.

If connector numbers are shown in Reference Area, these connector symbols are not shown in Connector Area. For terminal arrangement of these connectors, refer to the foldout page at the end of this manual.

Joint connector

Joint connector symbols are shown in Connector Area in the wiring diagram concerned. Foldout page also carries inside wiring layout together with such joint connector symbols.

Example

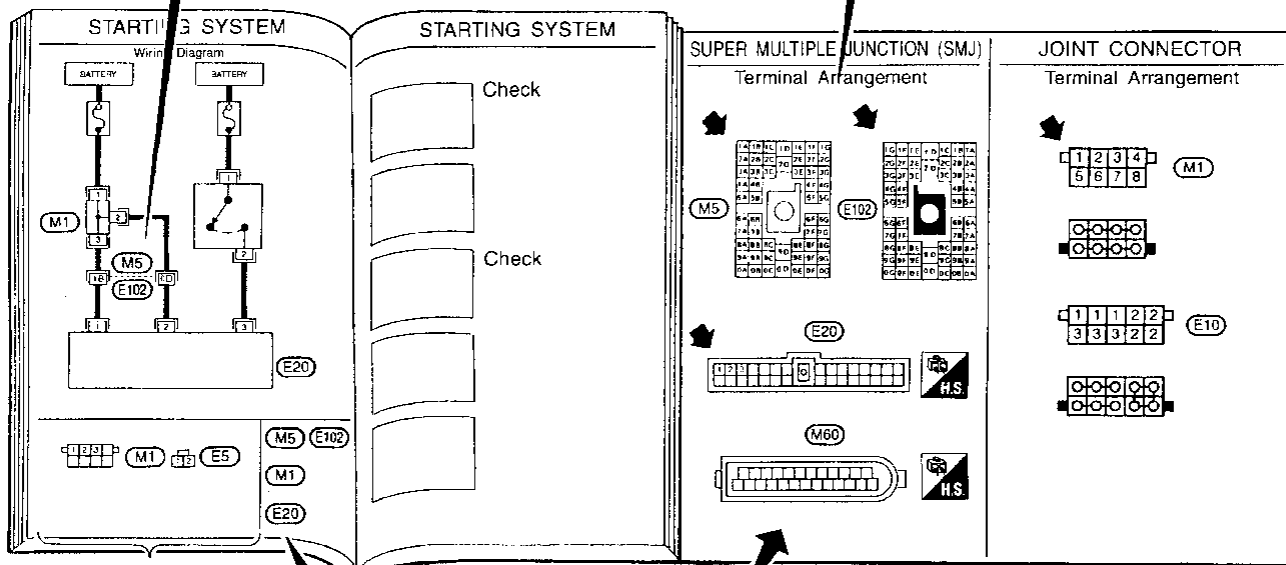
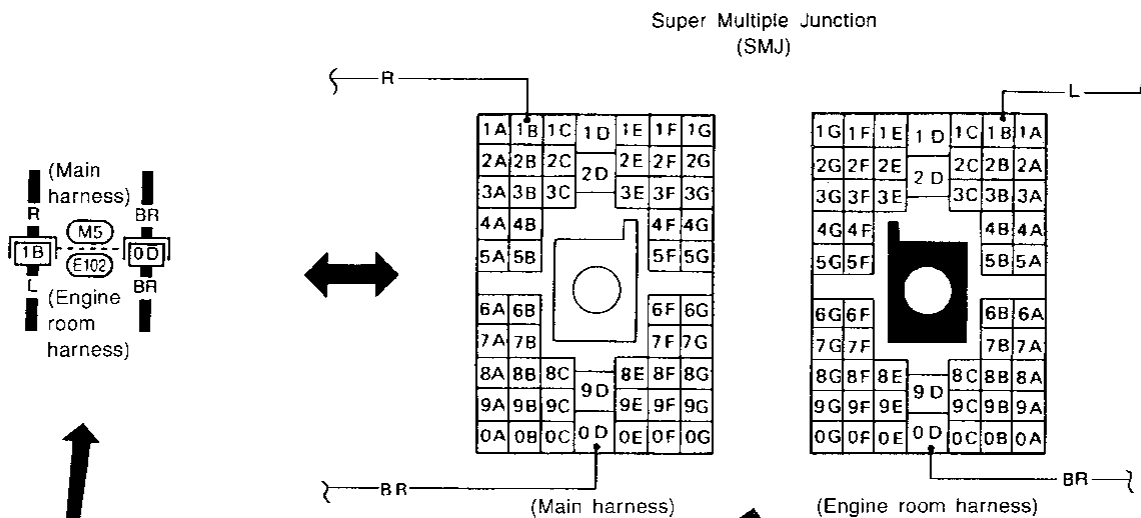

Reference Area:
Refer to the foldout page for the terminal arrangement of the connectors shown here in the "Reference Area".

SG1943

HOW TO READ WIRING DIAGRAMS

Description (Cont'd)

SPLICE LOCATION

- "GT2", "T4" etc., which are shown in the wiring diagram, refer to wiring harness splice points. These points are located in shaded areas "GT2", "T4", etc. in illustrations under the title "SPLICE LOCATION".
- Wiring harness splice points are subject to change without prior notice.

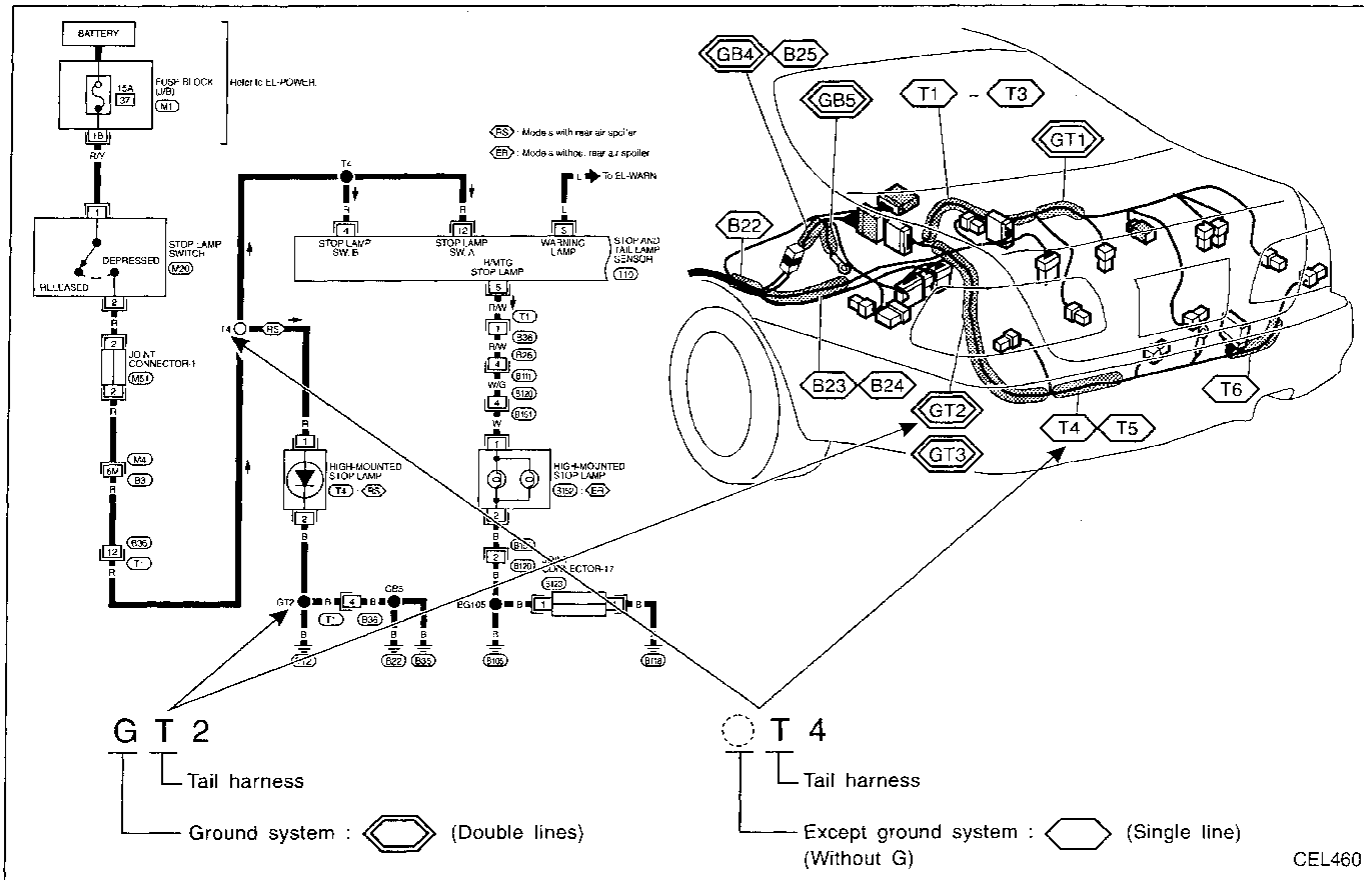

HOW TO READ WIRING DIAGRAMS

Wiring Diagram Codes (Cell Codes)

Use the chart below to find out what each wiring diagram code stands for.

Refer to the wiring diagram code in the alphabetical index to find the location (page number) of each wiring diagram.

Code	Section	Wiring Diagram Name
AAC/V	EC	IACV-AAC Valve
A/C	HA	Air Conditioner
ALT	EC	Alternator
ASCD	EL	Automatic Speed Control Device (ASCD)
A/T	AT	Automatic Transmission
AT/IND	EL	A/T Indicator
AT/C	EC	A/T Control
AUDIO	EL	Audio
AUT/DP	EL	Automatic Drive Positioner — IVMS
BACK/L	EL	Back-up Lamp
CHARGE	EL	Charging System
CHIME	EL	Warning Chime
CKPS	EC	Crankshaft Position Sensor (OBD)
CMPS	EC	Camshaft Position Sensor
COMM	EL	LAN — Communication Check Power Supply & Ground
COOL/F	EC	Cooling Fan Control
DEF	EL	Rear Window Defogger
D/LOCK	EL	Power Door Lock — IVMS
DTRL	EL	Headlamp - With Daytime Light System
ECTS	EC	Engine Coolant Temperature Sensor
EGRC1	EC	EGR System Function
EGRC/V	EC	EGRC-Solenoid Valve
EGR/TS	EC	EGR Temperature Sensor
EPS	ST	Electric Controlled Power Steering System
F/FOG	EL	Front Fog Lamp
FO2H-L	EC	Front Heated Oxygen Sensor Heater (Left Bank)
FO2H-R	EC	Front Heated Oxygen Sensor Heater (Right Bank)
FPCM	EC	Fuel Pump Control Module
F/PUMP	EC	Fuel Pump Control
FRO2LH	EC	Front Heated Oxygen Sensor (Front HO2S) (Left bank)
FRO2RH	EC	Front Heated Oxygen Sensor (Front HO2S) (Right bank)

Code	Section	Wiring Diagram Name
FUELLH	EC	Fuel Injection System Function (Left Bank)
FUEL RH	EC	Fuel Injection System Function (Right Bank)
H/LAMP	EL	Headlamp - Without Daytime Light System
HORN	EL	Horn, Cigarette Lighter and Clock
H/SEAT	EL	Heated Seat
IATS	EC	Intake Air Temperature Sensor
IGN/SG	EC	Ignition Signal
ILL	EL	Illumination
I/MIRR	EL	Inside Mirror
INJECT	EC	Injector
INT/L	EL	Interior, Spot and Trunk Room Lamps
IVC-L	EC	Intake Valve Timing Control Solenoid Valve LH
IVC-R	EC	Intake Valve Timing Control Solenoid Valve RH
IVCS-L	EC	Intake Valve Timing Control Position Sensor LH
IVCS-R	EC	Intake Valve Timing Control Position Sensor RH
KS	EC	Knock Sensor
LOAD	EC	Load Signal
MAFS	EC	Mass Air Flow Sensor
MAIN	EC	Main Power Supply and Ground Circuit
METER	EL	Speedometer, Tachometer, Temp., Oil and Fuel Gauges
MIL	EC	MIL, Data Link Connector For CONSULT, GST
MIRROR	EL	Door Mirror
MULTI	EL	Multi-remote Control System — IVMS
NATS	EL	NATS (Nissan Anti-Theft System)
P/ANT	EL	Power Antenna
PHONE	EL	Telephone
PNP/SW	EC	Park/Neutral Position Switch
POWER	EL	Power Supply Routing
PST/SW	EC	Power Steering Oil Pressure Switch
ROOM/L	EL	Interior Lamp Control — IVMS

GI

MA

EM

LC

EC

FE

AT

PD

FA

RA

BR

ST

RS

BT

HA

EL

IDX

HOW TO READ WIRING DIAGRAMS

Wiring Diagram Codes (Cell Codes) (Cont'd)

Code	Section	Wiring Diagram Name
RO2H-L	EC	Rear Heated Oxygen Sensor Heater LH
RO2H-R	EC	Rear Heated Oxygen Sensor Heater RH
RRO2LH	EC	Rear Heated Oxygen Sensor LH
RRO2RH	EC	Rear Heated Oxygen Sensor RH
SEAT	EL	Power Seat
SHIFT	AT	A/T Shift Lock System
SROOF	EL	Sunroof
SRS	RS	Supplemental Restraint System
S/SIG	EC	Start Signal
START	EL	Starting System
STEP/L	EL	Step Lamp — IVMS
STOP/L	EL	Stop lamp
STPS	EC	Secondary Throttle Position Sensor
SW/ILL	EL	Illumination — IVMS

Code	Section	Wiring Diagram Name
TAIL/L	EL	Parking, License, Tail and Stop Lamps
TCS	EC, BR	Traction Control System
TCS/SW	EC	TCS Signal
T&FLID	EL	Trunk Lid and Fuel Filler Lid Opener
THEFT	EL	Theft Warning System — IVMS
TPS	EC	Throttle Position Sensor
TRNSMT	EL	Integrated Homelink Transmitter
TURN	EL	Turn Signal and Hazard Warning Lamps
VSS	EC	Vehicle Speed Sensor
VTCS	EC	VTC Sensor
WARN	EL	Warning Lamps
WINDOW	EL	Power Window — IVMS
WIPER	EL	Front Wiper and Washer

HOW TO PERFORM EFFICIENT DIAGNOSIS FOR AN ELECTRICAL INCIDENT

Work Flow

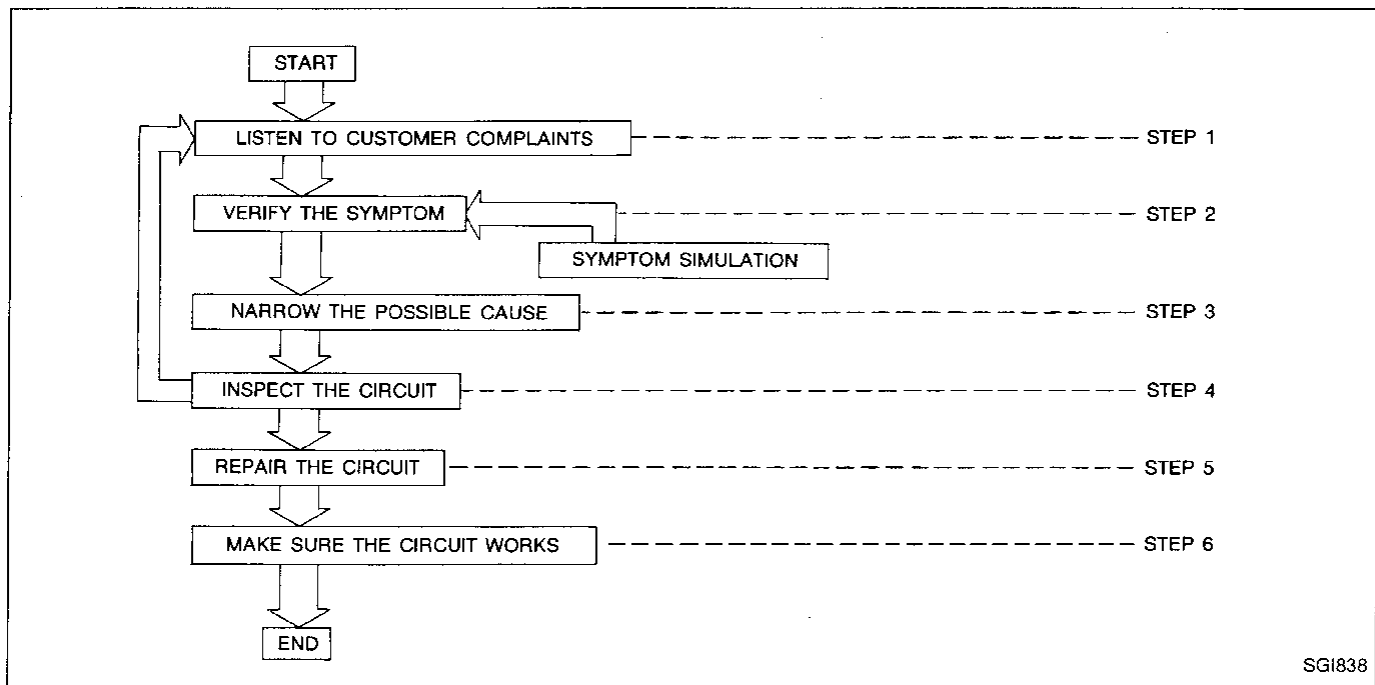

STEP	DESCRIPTION
STEP 1	Get detailed information about the conditions and the environment when the incident occurred. The following are key pieces of information required to make a good analysis: WHAT Vehicle Model, Engine, Transmission and the System (i.e. Radio). WHEN Date, Time of Day, Weather Conditions, Frequency. WHERE Road Conditions, Altitude and Traffic Situation. HOW System Symptoms, Operating Conditions (Other Components Interaction). Service History and if any After Market Accessories have been installed.
STEP 2	Operate the system, road test if necessary. Verify the parameter of the incident. If the problem can not be duplicated, refer to "Incident Simulation Tests" next page.
STEP 3	Get the proper diagnosis materials together including: POWER SUPPLY ROUTING System Operation Descriptions Applicable Service Manual Sections Check For Any Service Bulletin Identify where to begin diagnosis based upon your knowledge of the system operation and the customer comments.
STEP 4	Inspect the system for mechanical binding, loose connectors or wiring damage. Determine which circuits and components are involved and diagnose using the Power Supply Routing and Harness Layouts.
STEP 5	Repair or replace the incident circuit or component.
STEP 6	Operate the system in all modes. Verify the system works properly under all conditions. Make sure you have not inadvertently created a new incident during your diagnosis or repair steps.

GI
MA
EM
LC
EC
FE
AT
PD
FA
RA
BR
ST
RS
BT
HA
EL
IDX

Incident Simulation Tests

INTRODUCTION

Sometimes the symptom is not present when the vehicle is brought in for service. If possible, re-create the conditions present at the time of the incident. Doing so may help avoid a No Trouble Found Diagnosis. The following section illustrates ways to simulate the conditions/environment under which the owner experiences an electrical incident.

The section is broken into the six following topics:

- Vehicle vibration
- Heat sensitive
- Freezing
- Water intrusion
- Electrical load
- Cold or hot start up

Get a thorough description of the incident from the customer. It is important for simulating the conditions of the problem.

VEHICLE VIBRATION

The problem may occur or become worse while driving on a rough road or when engine is vibrating (idle with A/C on). In such a case, you will want to check for a vibration related condition. Refer to the illustration below.

Connectors & harness

Determine which connectors and wiring harness would affect the electrical system you are inspecting. **Gently** shake each connector and harness while monitoring the system for the incident you are trying to duplicate. This test may indicate a loose or poor electrical connection.

Hint

Connectors can be exposed to moisture. It is possible to get a thin film of corrosion on the connector terminals. A visual inspection may not reveal this without disconnecting the connector. If the problem occurs intermittently, perhaps the problem is caused by corrosion. It is a good idea to disconnect, inspect and clean the terminals on related connectors in the system.

Sensors & relays

Gently apply a slight vibration to sensors and relays in the system you are inspecting. This test may indicate a loose or poorly mounted sensor or relay.

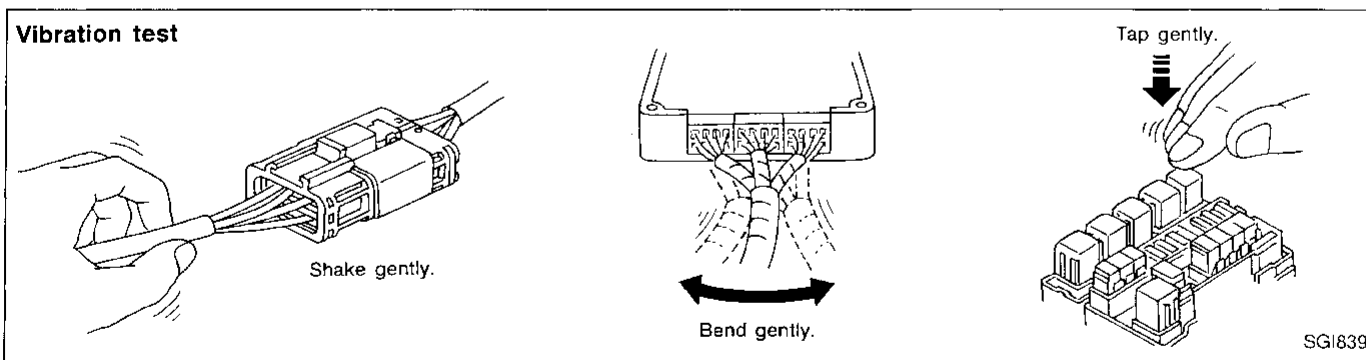

HOW TO PERFORM EFFICIENT DIAGNOSIS FOR AN ELECTRICAL INCIDENT

Incident Simulation Tests (Cont'd)

Possible cause

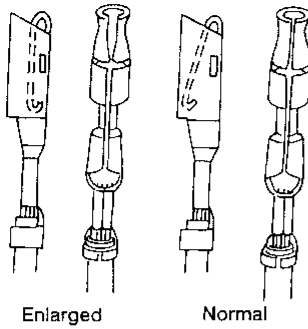

DEFORMED (ENLARGED) FEMALE TERMINALS

Any probe entering the terminal may enlarge the contact spring opening creating an intermittent signal.

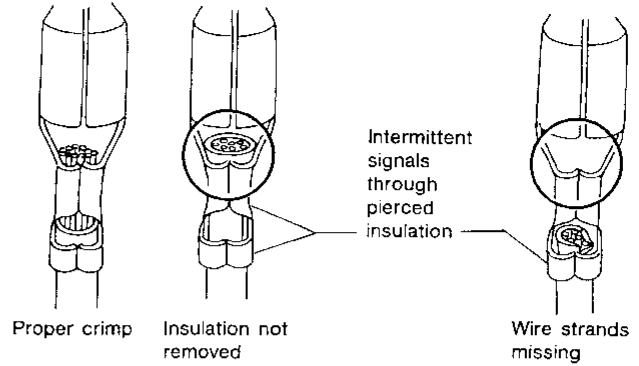

DEFECTIVE INSULATION STRIPPING

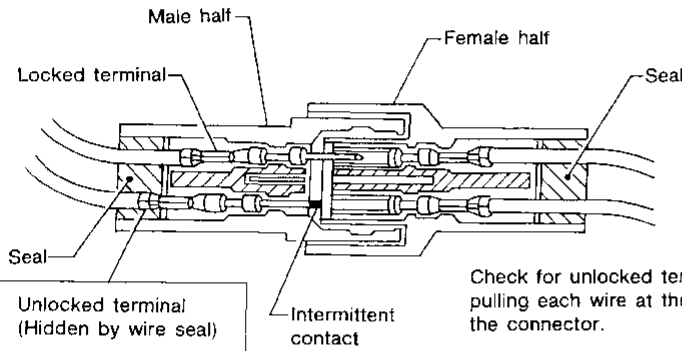

TERMINAL NOT PROPERLY SEATED

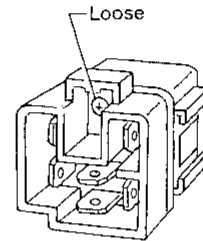

SGI840

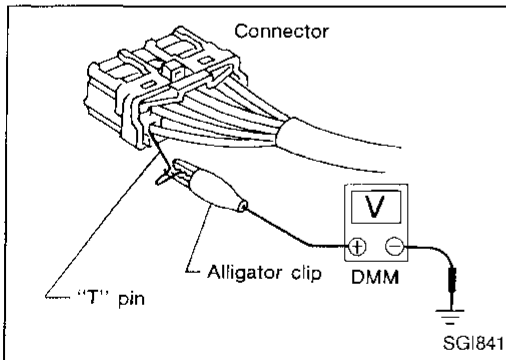

Tester probe

When probing a connector it is possible to enlarge the contact spring opening. If this occurs it may create an intermittent signal in the circuit. When probing a connector, use care not to enlarge the opening. The probe of the Digital Multimeter (DMM) may not fit into the connector cavity. In such cases make an extension of a "T" pin and probe it from the harness side of the connector. Most DMMs have accessory alligator clips. Slide these over the probe to allow clipping the "T" pin for a better contact. If you have any difficulty probing a terminal, inspect the terminal. Ensure you have not accidentally opened the contact spring or pulled a wire loose.

GI
MA
EM
LC
EC
FE
AT
PD
FA
RA
BR
ST
RS
BT
HA
EL
IDX

HOW TO PERFORM EFFICIENT DIAGNOSIS FOR AN ELECTRICAL INCIDENT

Incident Simulation Tests (Cont'd)

Engine compartment

There are several reasons a vehicle or engine vibration could cause an electrical complaint. Some of the things to check for are:

- Connectors not fully seated.
- Wiring harness not long enough and is being stressed due to engine vibrations or rocking.
- Wires laying across brackets or moving components.
- Loose, dirty or corroded ground wires.
- Wires routed too close to hot components.

To inspect components under the hood, start by verifying the integrity of ground connections. (Refer to GROUND INSPECTION described later.) First check that the system is properly grounded. Then check for loose connection by **gently shaking** the wiring or components as previously explained. Using the wiring diagrams inspect the wiring for continuity.

Behind the instrument panel

An improperly routed or improperly clamped harness can become pinched during accessory installation. Vehicle vibration can aggravate a harness which is routed along a bracket or near a screw.

Under seating areas

An unclamped or loose harness can cause wiring to be pinched by seat components (such as slide guides) during vehicle vibration. If the wiring runs under seating areas, inspect wire routing for possible damage or pinching.

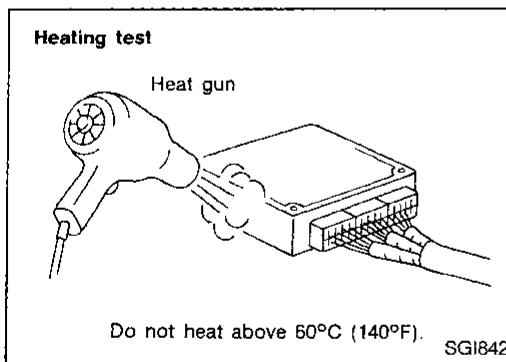

HEAT SENSITIVE

The owner's problem may occur during hot weather or after car has sat for a short time. In such cases you will want to check for a heat sensitive condition.

To determine if an electrical component is heat sensitive, heat the component with a heat gun or equivalent.

Do not heat components above 60°C (140°F). If incident occurs while heating the unit, either replace or properly insulate the component.

HOW TO PERFORM EFFICIENT DIAGNOSIS FOR AN ELECTRICAL INCIDENT

Incident Simulation Tests (Cont'd)

FREEZING

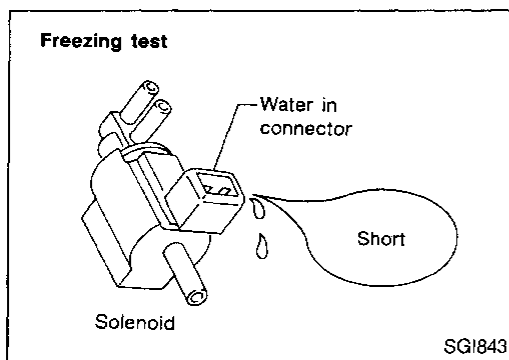

The customer may indicate the incident goes away after the car warms up (winter time). The cause could be related to water freezing somewhere in the wiring/electrical system.

There are two methods to check for this. The first is to arrange for the owner to leave his car overnight. Make sure it will get cold enough to demonstrate his complaint. Leave the car parked outside overnight. In the morning, do a quick and thorough diagnosis of those electrical components which could be affected.

The second method is to put the suspect component into a freezer long enough for any water to freeze. Reinstall the part into the car and check for the reoccurrence of the incident. If it occurs, repair or replace the component.

GI

MA

EM

LC

EC

FE

AT

PD

FA

RA

BR

ST

RS

BT

HA

EL

IDX

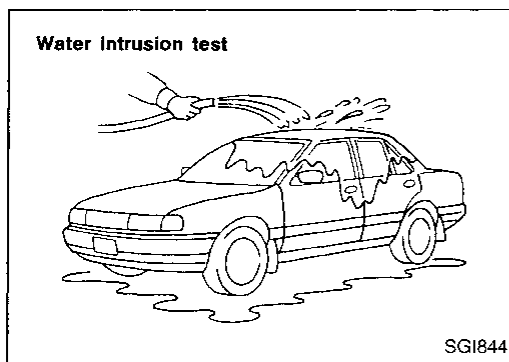

WATER INTRUSION

The incident may occur only during high humidity or in rainy/snowy weather. In such cases the incident could be caused by water intrusion on an electrical part. This can be simulated by soaking the car or running it through a car wash.

Do not spray water directly on any electrical components.

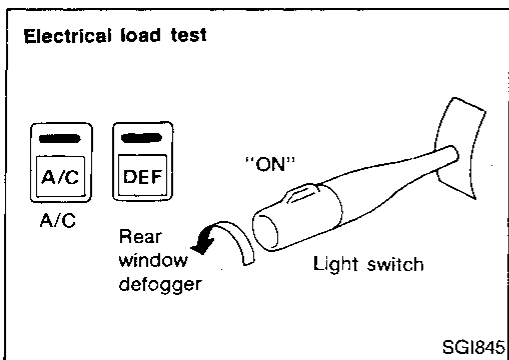

ELECTRICAL LOAD

The incident may be electrical load sensitive. Perform diagnosis with all accessories (including A/C, rear window defogger, radio, fog lamps) turned on.

COLD OR HOT START UP

On some occasions an electrical incident may occur only when the car is started cold. Or it may occur when the car is restarted hot shortly after being turned off. In these cases you may have to keep the car overnight to make a proper diagnosis.

Circuit Inspection

CONNECTOR AND TERMINAL PIN KIT

Use the connector and terminal pin kit listed below when replacing connectors or terminals.

The connector and terminal pin kit contains some of the most commonly used INFINITI connectors and terminals.

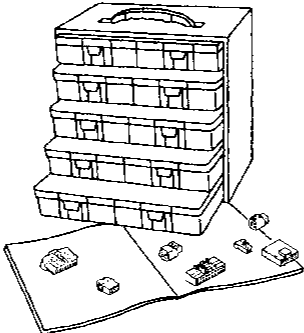
Tool number (Kent-Moore No.) Tool name	Description
— (J38751-95NI) Connector and terminal pin kit	 <p>AGI063</p>

INTRODUCTION

In general, testing electrical circuits is an easy task if it is approached in a logical and organized method. Before beginning it is important to have all available information on the system to be tested. Also, get a thorough understanding of system operation. Then you will be able to use the appropriate equipment and follow the correct test procedure.

You may have to simulate vehicle vibrations while testing electrical components. **Gently shake** the wiring harness or electrical component to do this.

OPEN A circuit is open when there is no continuity through a section of the circuit.

SHORT There are two types of shorts.

- **SHORT CIRCUIT**

When a circuit contacts another circuit and causes the normal resistance to change.

- **SHORT TO GROUND**

When a circuit contacts a ground source and grounds the circuit.

TESTING FOR "OPENS" IN THE CIRCUIT

Before you begin to diagnose and test the system, you should rough sketch a schematic of the system. This will help you to logically walk through the diagnosis process. Drawing the sketch will also reinforce your working knowledge of the system.

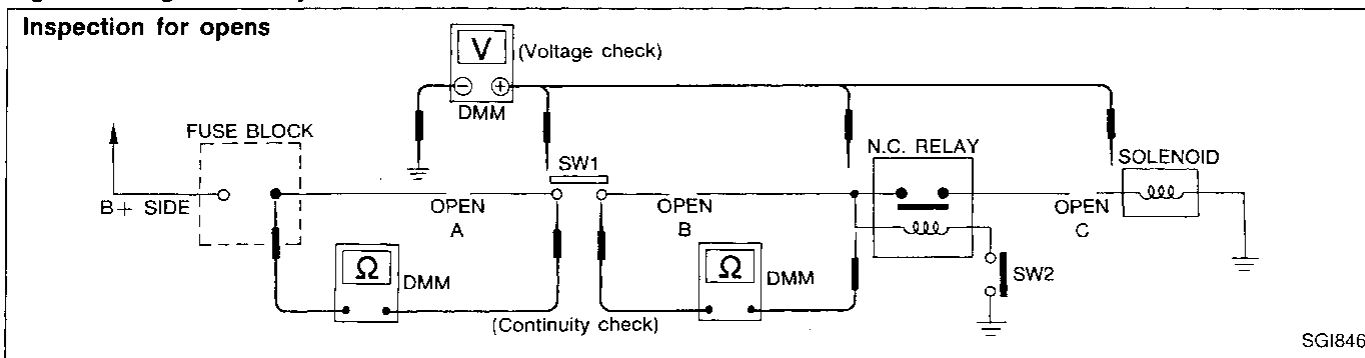

HOW TO PERFORM EFFICIENT DIAGNOSIS FOR AN ELECTRICAL INCIDENT

Circuit Inspection (Cont'd)

Continuity check method

The continuity check is used to find an open in the circuit. The Digital Multimeter (DMM) set on the resistance function will indicate an open circuit as over limit (OL, no beep tone or no ohms symbol). Make sure to always start with the DMM at the highest resistance level.

To help in understanding the diagnosis of open circuits please refer to the schematic above.

1. Disconnect the battery negative cable.
2. Start at one end of the circuit and work your way to the other end. (At the fuse block in this example)
3. Connect one probe of the DMM to the fuse block terminal on the load side.
4. Connect the other probe to the fuse block (power) side of SW1. Little or no resistance will indicate that portion of the circuit has good continuity. If there were an open in the circuit, the DMM would indicate an over limit or infinite resistance condition. (point A)
5. Connect the probes between SW1 and the relay. Little or no resistance will indicate that portion of the circuit has good continuity. If there were an open in the circuit, the DMM would indicate an over limit or infinite resistance condition. (point B)
6. Connect the probes between the relay and the solenoid. Little or no resistance will indicate that portion of the circuit has good continuity. If there were an open in the circuit, the DMM would indicate an over limit or infinite resistance condition. (point C)

Any circuit can be diagnosed using the approach in the above example.

Voltage check method

To help in understanding the diagnosis of open circuits please refer to the previous schematic.

In any powered circuit, an open can be found by methodically checking the system for the presence of voltage. This is done by switching the DMM to the voltage function.

1. Connect one probe of the DMM to a known good ground.
2. Begin probing at one end of the circuit and work your way to the other end.
3. With SW1 open, probe at SW1 to check for voltage.
voltage; open is further down the circuit than SW1.
no voltage; open is between fuse block and SW1 (point A).
4. Close SW1 and probe at relay.
voltage; open is further down the circuit than the relay.
no voltage; open is between SW1 and relay (point B).
5. Close the relay and probe at the solenoid.
voltage; open is further down the circuit than the solenoid.
no voltage; open is between relay and solenoid (point C).

Any powered circuit can be diagnosed using the approach in the above example.

TESTING FOR "SHORTS" IN THE CIRCUIT

To simplify the discussion of shorts in the system please refer to the schematic below.

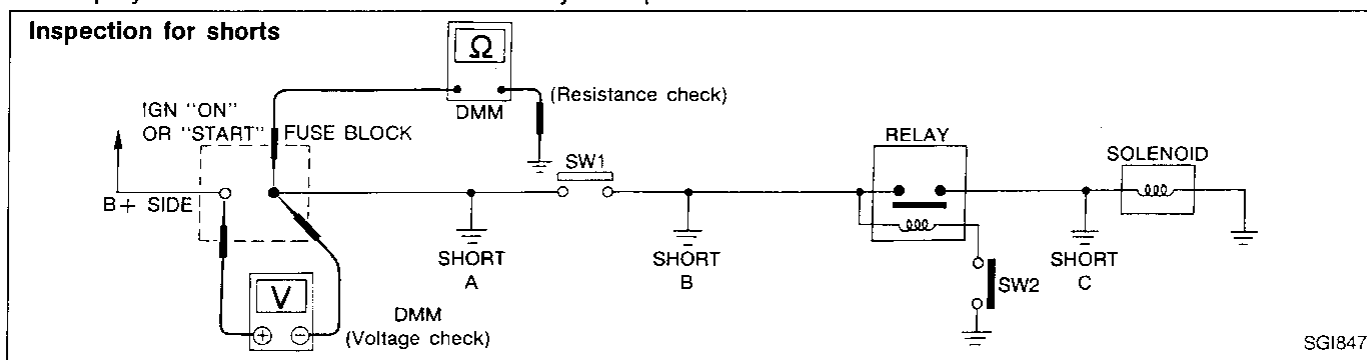

HOW TO PERFORM EFFICIENT DIAGNOSIS FOR AN ELECTRICAL INCIDENT

Circuit Inspection (Cont'd)

Resistance check method

1. Disconnect the battery negative cable and remove the blown fuse.
2. Disconnect all loads (SW1 open, relay disconnected and solenoid disconnected) powered through the fuse.
3. Connect one probe of the ohmmeter to the load side of the fuse terminal. Connect the other probe to a known good ground.
4. With SW1 open, check for continuity.
continuity; short is between fuse terminal and SW1 (point A).
no continuity; short is further down the circuit than SW1.
5. Close SW1 and disconnect the relay. Put probes at the load side of fuse terminal and a known good ground. Then, check for continuity.
continuity; short is between SW1 and the relay (point B).
no continuity; short is further down the circuit than the relay.
6. Close SW1 and jump the relay contacts with jumper wire. Put probes at the load side of fuse terminal and a known good ground. Then, check for continuity.
continuity; short is between relay and solenoid (point C).
no continuity; check solenoid, retrace steps.

Voltage check method

1. Remove the blown fuse and disconnect all loads (i.e. SW1 open, relay disconnected and solenoid disconnected) powered through the fuse.
2. Turn the ignition key to the ON or START position. Verify battery voltage at the B + side of the fuse terminal (one lead on the B + terminal side of the fuse block and one lead on a known good ground).
3. With SW1 open and the DMM leads across both fuse terminals, check for voltage.
voltage; short is between fuse block and SW1 (point A).
no voltage; short is further down the circuit than SW1.
4. With SW1 closed, relay and solenoid disconnected and the DMM leads across both fuse terminals, check for voltage.
voltage; short is between SW1 and the relay (point B).
no voltage; short is further down the circuit than the relay.
5. With SW1 closed, relay contacts jumped with fused jumper wire check for voltage.
voltage; short is down the circuit of the relay or between the relay and the disconnected solenoid (point C).
no voltage; retrace steps and check power to fuse block.

GROUND INSPECTION

Ground connections are very important to the proper operation of electrical and electronic circuits. Ground connections are often exposed to moisture, dirt and other corrosive elements. The corrosion (rust) can become an unwanted resistance. This unwanted resistance can change the way a circuit works.

Electronically controlled circuits are very sensitive to proper grounding. A loose or corroded ground can drastically affect an electronically controlled circuit. A poor or corroded ground can easily affect the circuit. Even when the ground connection looks clean, there can be a thin film of rust on the surface.

When inspecting a ground connection follow these rules:

1. Remove the ground bolt screw or clip.
2. Inspect all mating surfaces for tarnish, dirt, rust, etc.
3. Clean as required to assure good contact.
4. Reinstall bolt or screw securely.
5. Inspect for "add-on" accessories which may be interfering with the ground circuit.
6. If several wires are crimped into one ground eyelet terminal, check for proper crimps. Make sure all of the wires are clean, securely fastened and providing a good ground path. If multiple wires are cased in one eyelet make sure no ground wires have excess wire insulation.

Circuit Inspection (Cont'd)

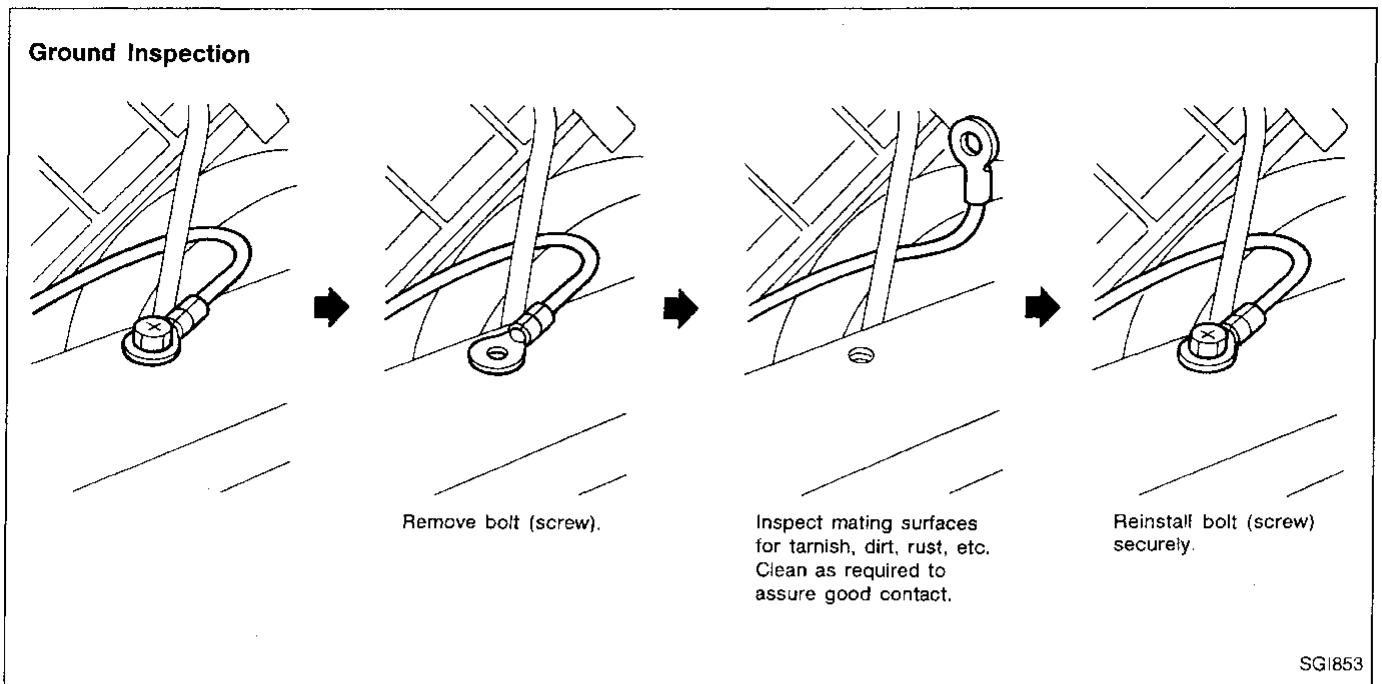

VOLTAGE DROP TESTS

Voltage drop tests are often used to find components or circuits which have excessive resistance. A voltage drop in a circuit is caused by a resistance **when the circuit is in operation**.

Check the wire in the illustration. When measuring resistance with ohmmeter, contact by a single strand of wire will give reading of 0 ohms. This would indicate a good circuit. When the circuit operates, this single strand of wire is not able to carry the current. The single strand will have a high resistance to the current. This will be picked up as a slight voltage drop.

Unwanted resistance can be caused by many situations as follows:

- Undersized wiring (single strand example)
- Corrosion on switch contacts
- Loose wire connections or splices.

If repairs are needed always use wire that is of the same or larger gauge.

Measuring voltage drop — Accumulated method

1. Connect the voltmeter across the connector or part of the circuit you want to check. The positive lead of the voltmeter should be closer to power and the negative lead closer to ground.
2. Operate the circuit.
3. The voltmeter will indicate how many volts are being used to “push” current through that part of the circuit.

Note in the illustration that there is an excessive 4.1 volt drop between the battery and the bulb.

GI
MA
EM
LC
EC
FE
AT
PD
FA
RA
BR
ST
RS
BT
HA
EL
IDX

HOW TO PERFORM EFFICIENT DIAGNOSIS FOR AN ELECTRICAL INCIDENT

Circuit Inspection (Cont'd)

Symptom: Dim bulb or no operation

0 (zero) ohm resistance between switch and bulb

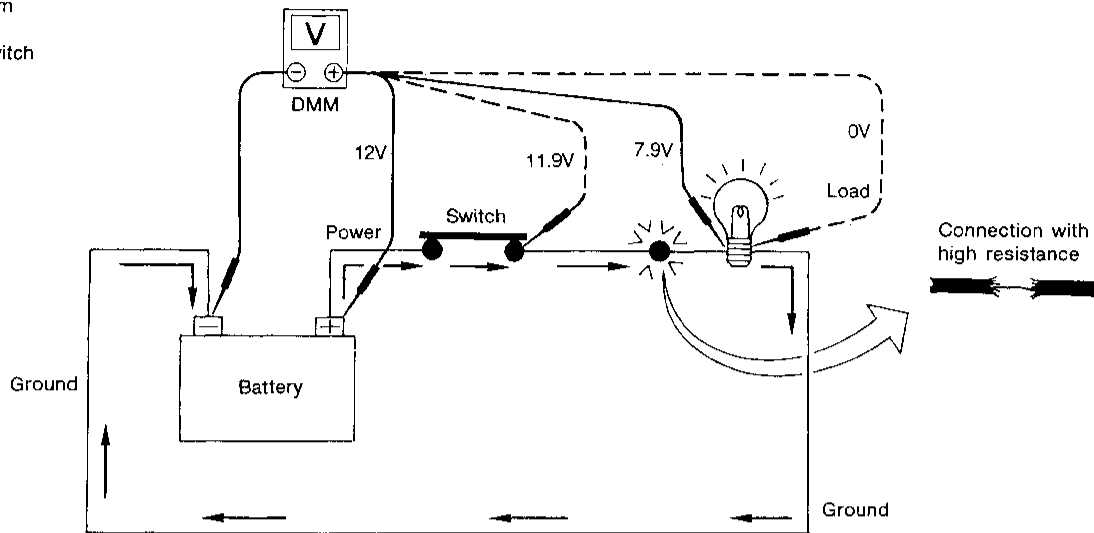

SGI848

Measuring voltage drop — Step by step

The step by step method is most useful for isolating excessive drops in low voltage systems (such as those in "Computer Controlled Systems").

Circuits in the "Computer Controlled System" operate on very low amperage.

The (Computer Controlled) system operations can be adversely affected by any variation in resistance in the system. Such resistance variation may be caused by poor connection, improper installation, improper wire gauge or corrosion.

The step by step voltage drop test can identify a component or wire with too much resistance.

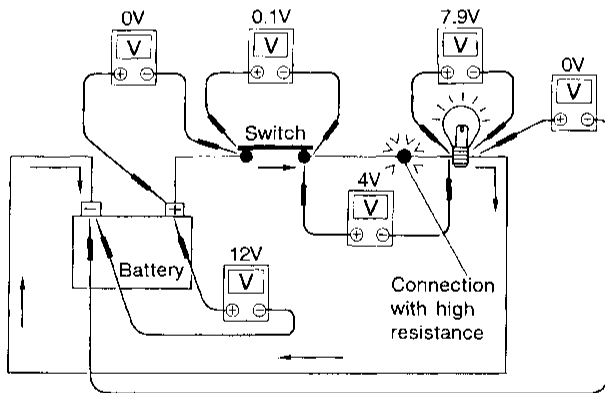

1. Connect the voltmeter as shown, starting at the battery and working your way around the circuit.
2. An unusually large voltage drop will indicate a component or wire that needs to be repaired. As you can see the illustration above, the poor connection causes a 4 volt drop.

The chart that follows illustrates some maximum allowable voltage drops. These values are given as a guideline, the exact value for each component may vary.

COMPONENT	VOLTAGE DROP
Wire	negligible <.001 volts
Ground Connections	Approx. 0.1 volts
Switch Contacts	Approx. 0.3 volts

SGI854

HOW TO PERFORM EFFICIENT DIAGNOSIS FOR AN ELECTRICAL INCIDENT

Circuit Inspection (Cont'd)

Relationship between open/short (high resistance) circuit and the ECM pin control

System Description: When the switch is ON, the ECM lights up the lamp.

Case 1

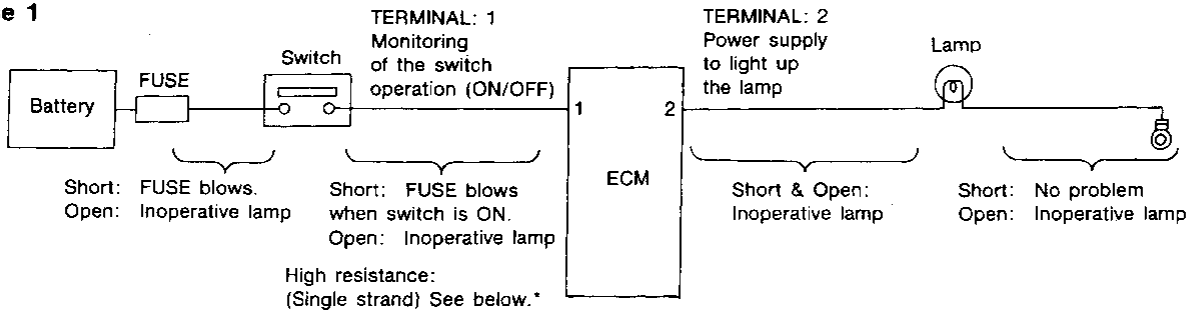

Input-output voltage chart

Pin No.	Item	Condition	Voltage value [V]	In case of high resistance such as single strand [V] *
1	Switch	Switch ON	Battery voltage	Lower than battery voltage Approx. 8 (Example)
		OFF	Approx. 0	Approx. 0
2	Lamp	Switch ON	Battery voltage	Approx. 0 (Inoperative lamp)
		OFF	Approx. 0	Approx. 0

The voltage value is based on the body ground.

* : If high resistance exists in the switch side circuit (caused by a single strand), terminal 1 does not detect battery voltage. ECM does not detect the switch is ON even if the switch does turn ON. Therefore, the ECM does not supply power to light up the lamp.

Case 2

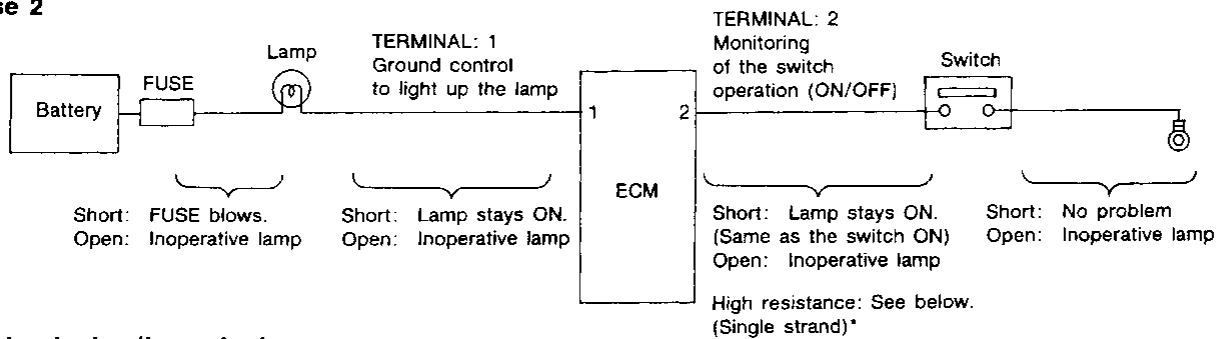

Input-output voltage chart

Pin No.	Item	Condition	Voltage value [V]	In case of high resistance such as single strand [V] *
1	Lamp	Switch ON	Approx. 0	Battery voltage (Inoperative lamp)
		OFF	Battery voltage	Battery voltage
2	Switch	Switch ON	Approx. 0	Higher than 0 Approx. 4 (Example)
		OFF	Approx. 5	Approx. 5

The voltage value is based on the body ground.

* : If high resistance exists in the switch side circuit (caused by a single strand), terminal 2 does not detect approx. 0V. ECM does not detect the switch is ON even if the switch does turn ON. Therefore, the ECM does not control ground to light up the lamp.

GI

MA

EM

LC

EC

FE

AT

PD

FA

RA

BR

ST

RS

BT

HA

EL

IDX

HOW TO FOLLOW FLOW CHART IN TROUBLE DIAGNOSES

NOTICE

The flow chart indicates work procedures required to diagnose problems effectively. Observe the following instructions before diagnosing.

- 1) Use the flow chart after locating probable causes of a problem following the "Preliminary Check", the "Symptom Chart" or the "Work Flow".
- 2) After repairs, re-check that the problem has been completely eliminated.
- 3) Refer to Component Parts and Harness Connector Location for the Systems described in each section for identification/location of components and harness connectors.
- 4) Refer to the Circuit Diagram for Quick Pinpoint Check. If you must check circuit continuity between harness connectors in more detail, such as when a sub-harness is used, refer to Wiring Diagram in each individual section and Harness Layout in EL section for identification of harness connectors.
- 5) When checking circuit continuity, ignition switch should be "OFF".
- 6) Before checking voltage at connectors, check battery voltage.
- 7) After accomplishing the Diagnostic Procedures and Electrical Components Inspection, make sure that all harness connectors are reconnected as they were.

Example

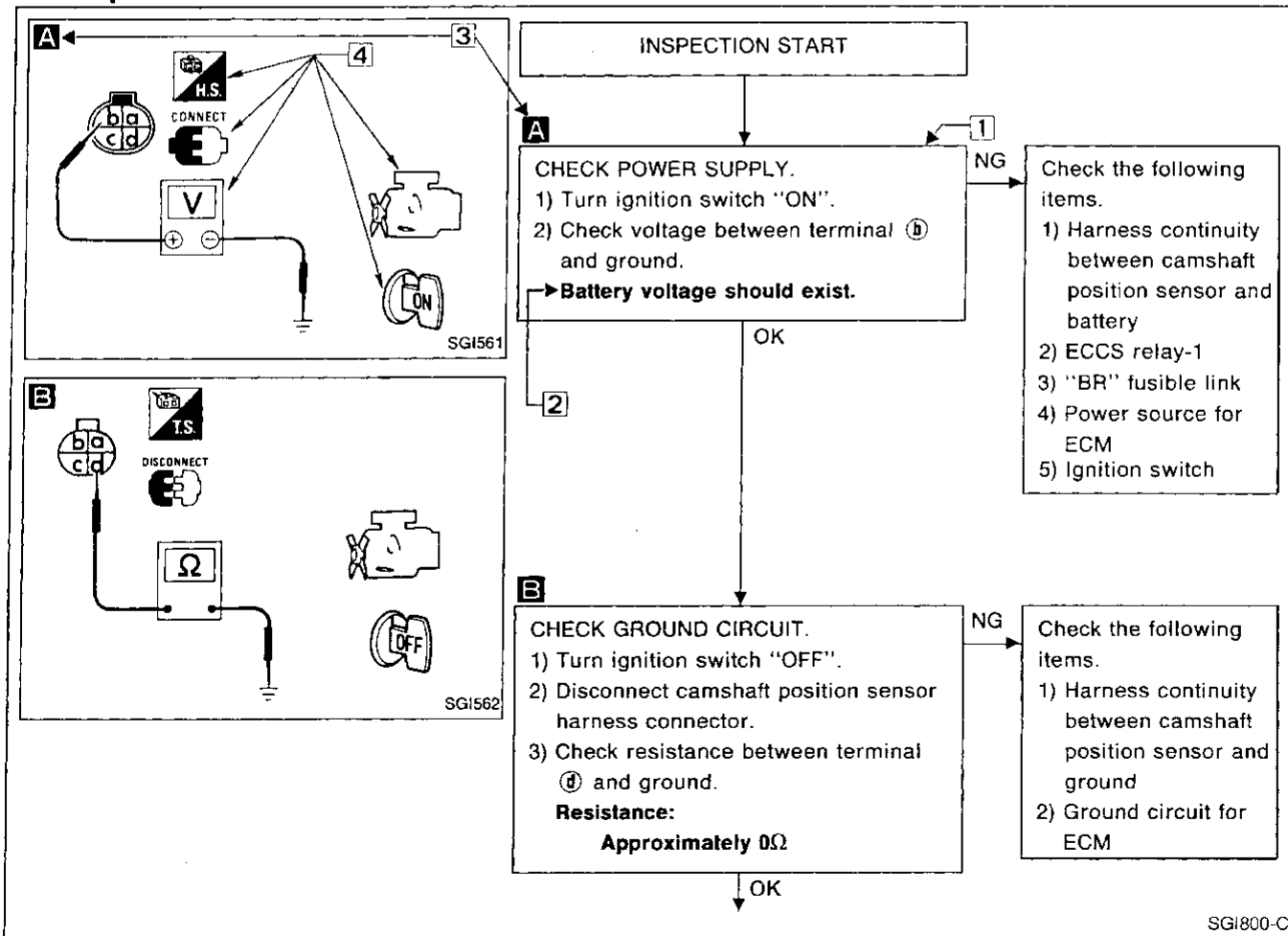

HOW TO FOLLOW THIS FLOW CHART

1 Work and diagnostic procedure

Start to diagnose a problem using procedures indicated in enclosed blocks, as shown in the following example.

A

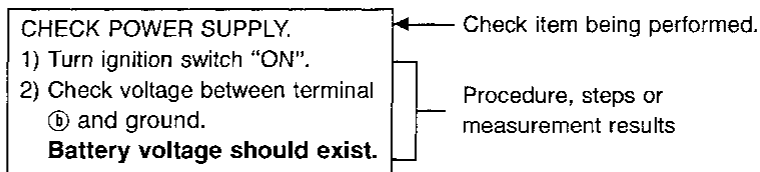

2 Measurement results

Required results are indicated in bold type in the corresponding block, as shown below:

These have the following meanings:

Battery voltage → 11 - 14V or approximately 12V
Voltage: Approximately 0V → Less than 1V

3 Cross reference of work symbols in the text and illustrations

Illustrations are provided as visual aids for work procedures. For example, symbol **A** indicated in the left upper portion of each illustration corresponds with the symbol in the flow chart for easy identification. More precisely, the procedure under the "CHECK POWER SUPPLY" outlined previously is indicated by illustration **A**.

4 Symbols used in illustrations

Symbols included in illustrations refer to measurements or procedures. Before diagnosing a problem, familiarize yourself with each symbol.

Direction mark

Refer to "CONNECTOR SYMBOLS" on GI-13.

GI

MA

EM

LC

EC

FE

AT

PD

FA

RA

BR

ST

RS

BT





























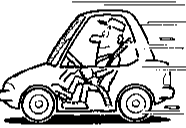



HA

EL

IDX

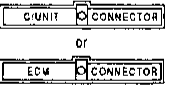
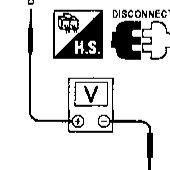
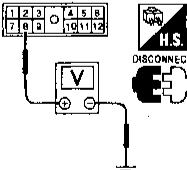
HOW TO FOLLOW FLOW CHART IN TROUBLE DIAGNOSES

Key to symbols signifying measurements or procedures

Symbol	Symbol explanation	Symbol	Symbol explanation
	Check after disconnecting the connector to be measured.		Procedure without CONSULT
	Check after connecting the connector to be measured.		Procedure with Generic Scan Tool (GST, OBD-II scan tool)
	Insert key into ignition switch.		Procedure without CONSULT or GST
	Remove key from ignition switch.		A/C switch is "OFF".
	Turn ignition switch to "OFF" position.		A/C switch is "ON".
	Turn ignition switch to "ON" position.		REC switch is "ON".
	Turn ignition switch to "START" position.		REC switch is "OFF".
	Turn ignition switch from "OFF" to "ACC" position.		DEF switch is "ON".
	Turn ignition switch from "ACC" to "OFF" position.		Apply positive voltage from battery with fuse directly to components.
	Turn ignition switch from "OFF" to "ON" position.		Drive vehicle.
	Turn ignition switch from "ON" to "OFF" position.		Disconnect battery negative cable.
	Do not start engine, or check with engine stopped.		Depress brake pedal.
	Start engine, or check with engine running.		Release brake pedal.
	Apply parking brake.		Depress accelerator pedal.
	Release parking brake.		Release accelerator pedal.
	Check after engine is warmed up sufficiently.	 <p>C-UNIT CONNECTOR or ECW CONNECTOR</p>  <p>H.S. DISCONNECT</p>  <p>DISCONNECT</p>	<p>Pin terminal check for SMJ type ECM and A/T control unit connectors. For details regarding the terminal arrangement, refer to the foldout page.</p>
	Voltage should be measured with a voltmeter.		
	Circuit resistance should be measured with an ohmmeter.		
	Current should be measured with an ammeter.		
	Procedure with CONSULT		

CONSULT CHECKING SYSTEM

Function and System Application

Diagnostic test mode	Function	ECCS	TCS	A/T	ABS	AIR BAG	ASCD	IVMS	AUTO A/C	NATS
Work support	This mode enables a technician to adjust some devices faster and more accurately by following the indications on CONSULT.	x	x	—	—	—	—	—	x	—
Self-diagnostic results	Self-diagnostic results can be read and erased quickly.	x	x	x	x	x	x	x	x	x
Trouble diagnostic record	Current self-diagnostic results and all trouble diagnostic records previously stored can be read.	—	—	—	—	x	—	—	—	—
ECU discriminated No.	Classification number of a replacement ECU can be read to prevent an incorrect ECU from being installed.	—	—	—	—	x	—	—	—	—
Data monitor	Input/Output data in the ECM can be read.	x	x	x	x	—	x	x	x	—
Active test	Diagnostic Test Mode in which CONSULT drives some actuators apart from the ECMs and also shifts some parameters in a specified range.	x	x	—	x	—	—	x	x	—
ECM part number	ECM part number can be read.	x	x	x	x	—	—	x	—	—
Function test	Conducted by CONSULT instead of a technician to determine whether each system is "OK" or "NG".	x	—	—	—	—	—	—	—	—
Control unit initialization	All registered ignition key IDs in NATS components can be initialized and new IDs can be registered.	—	—	—	—	—	—	—	—	x
Self-function check	ECM checks its own NATS communication interface.	—	—	—	—	—	—	—	—	x
SRT/OBD test value	The results of SRT (System Readiness Test) and the OBD Test Values/Test Limits can be read.	x	—	—	—	—	—	—	—	—

x: Applicable

Lithium Battery Replacement

CONSULT contains a lithium battery. When replacing the battery obey the following:

WARNING:

Replace the lithium battery with **SANYO Electric Co., Ltd., CR2032 only**. Use of another battery may present a risk of fire or explosion. The battery may present a fire or chemical burn hazard if mistreated. Do not recharge, disassemble or dispose of in fire.

Keep the battery out of reach of children and discard used battery conforming to the local regulations.

Checking Equipment

When ordering the below equipment, contact your INFINITI distributor.

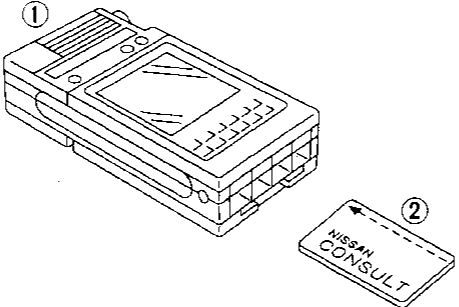
Tool name	Description
NISSAN CONSULT kit ① CONSULT unit and accessories ② Program card UE950, UE951 and NATS — E960U	

NT004

IDENTIFICATION INFORMATION

Model Variation

Destination	Body	Model	Engine	Transmission
Non-California	Sedan	BPFALGA-EUA	VH41DE	RE4R03A
California		BPFALGA-EVA		
Canada		BPFALGA-ENA		

Prefix and suffix designations:

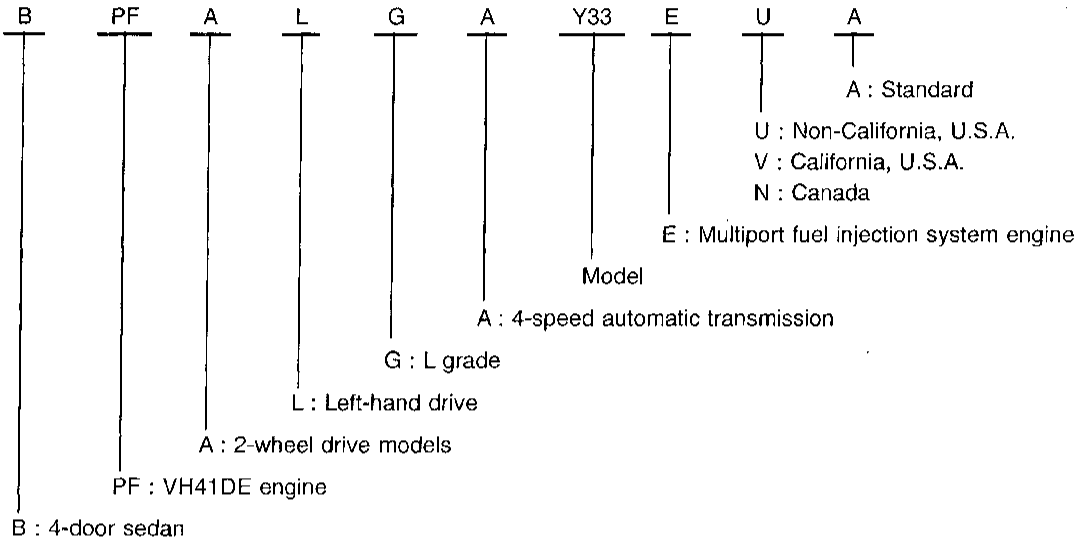

IDENTIFICATION INFORMATION

Identification Number

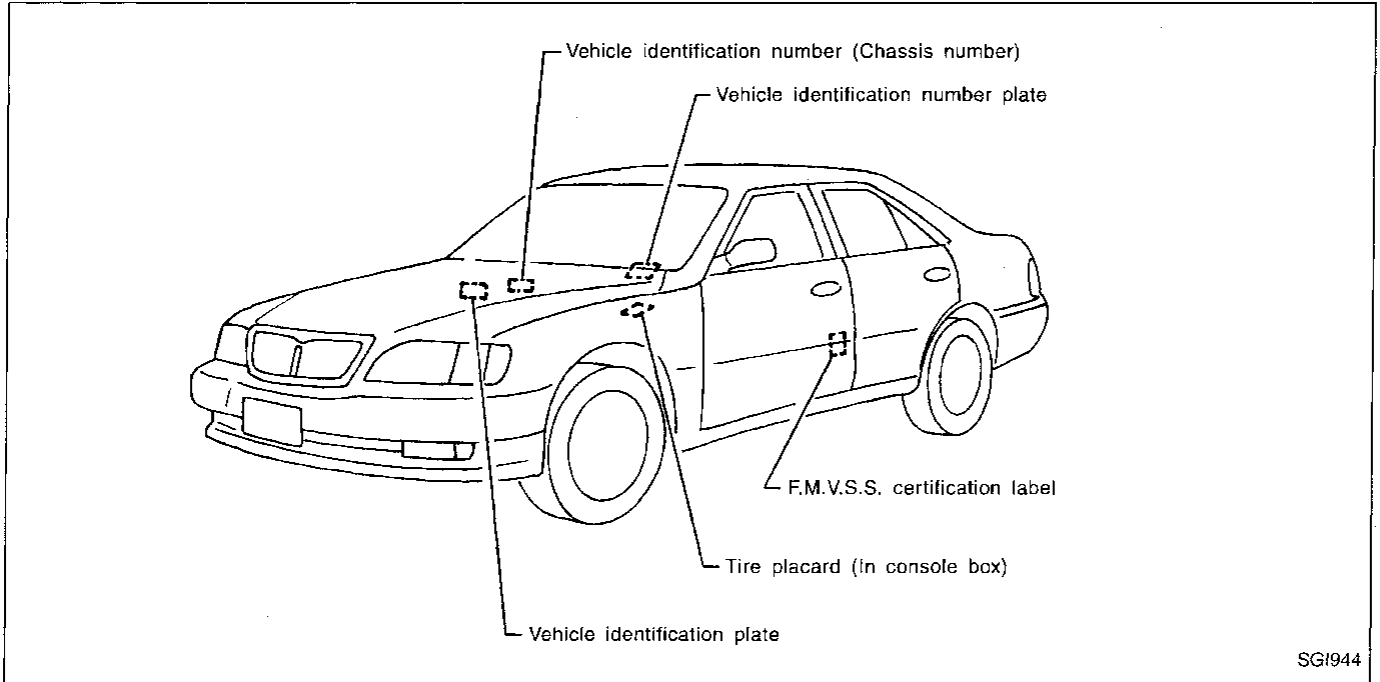

VEHICLE IDENTIFICATION NUMBER ARRANGEMENT

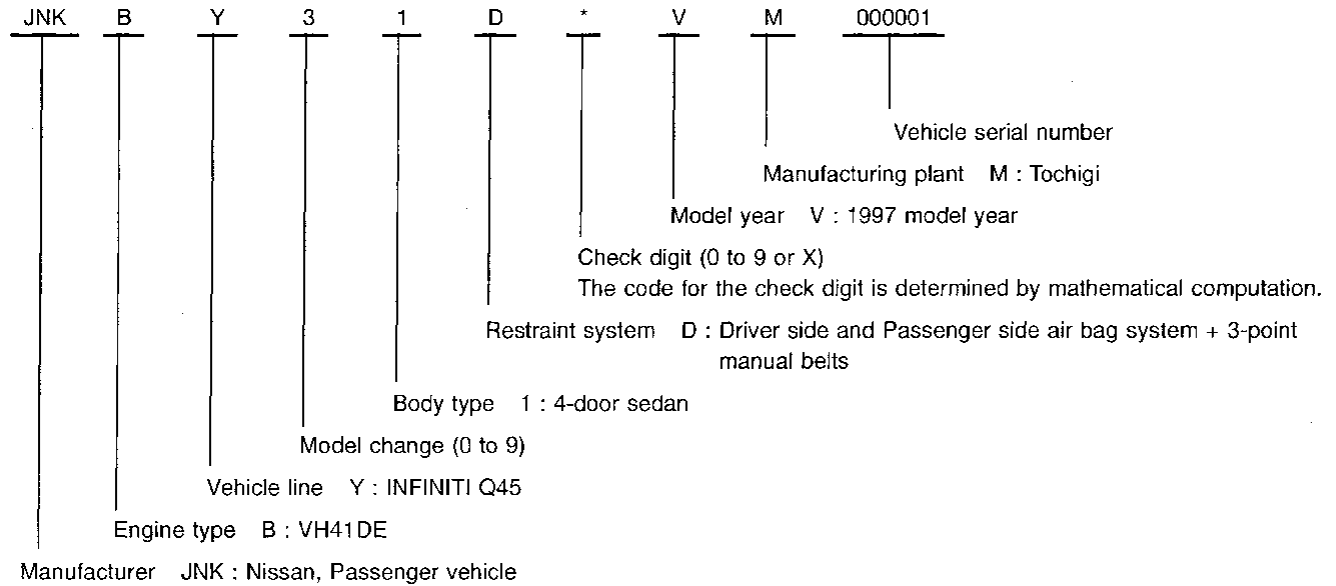

GI
MA
EM
LC
EC
FE
AT
PD
FA
RA
BR
ST
RS
BT
HA
EL
IDX

IDENTIFICATION INFORMATION

Identification Number (Cont'd)

IDENTIFICATION PLATE

NISSAN MOTOR CO., LTD. JAPAN

型式 TYPE
 TIPO △

CHASSIS NO. △
NO. DE CHASIS

MODEL △
MODELO

○ カラー COLOR TRIM △ △ ○
 トリム COLOR GUARNICION

エンジン ENGINE △ △ CC
ジン MOTOR

ミッション TRANS. AXLE △ △ PLANT
アクスル TRANS. EJE 工場 PLANTA

日産自動車株式会社 MADE IN JAPAN

- 1 Type
- 2 Vehicle identification number (Chassis number)
- 3 Model
- 4 Body color code
- 5 Trim color code
- 6 Engine model
- 7 Engine displacement
- 8 Transmission model
- 9 Axle model

SGI315

ENGINE SERIAL NUMBER

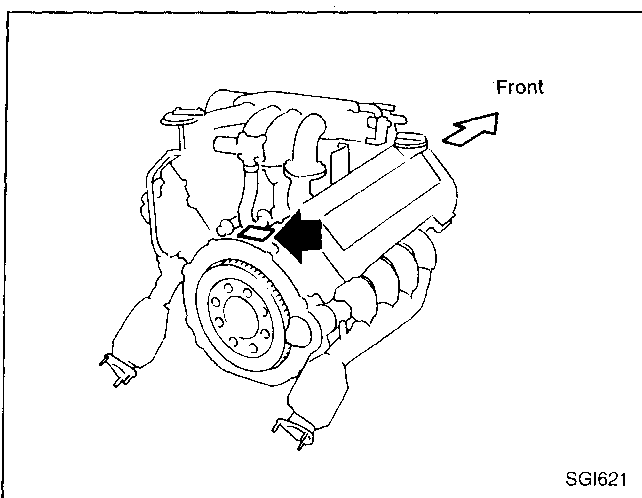

AUTOMATIC TRANSMISSION NUMBER

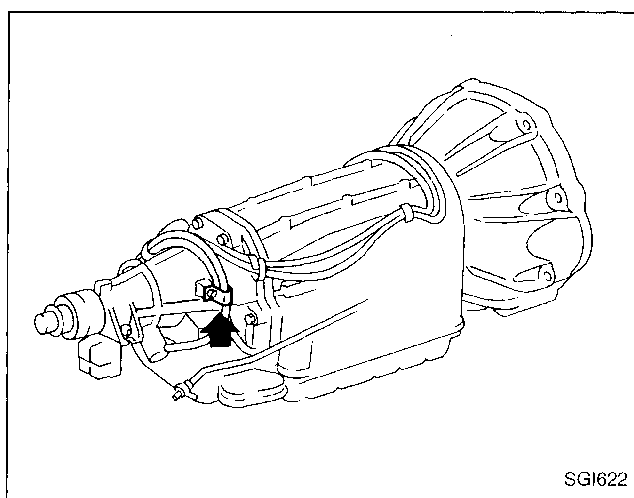

Dimensions

Unit: mm (in)

Overall length	5,060 (199.2)
Overall width	1,820 (71.7)
Overall height	1,445 (56.9)
Front tread	1,540 (60.6)
Rear tread	1,540 (60.6)
Wheelbase	2,830 (111.4)

Wheels and Tires

		Conventional	Spare (T-type)
Road wheel	Aluminum	16 x 7JJ	16 x 4T
	Offset mm (in)	40 (1.57)	30 (1.18)
Tire size		P215/60R16 94V	T135/90D16

LIFTING POINTS AND TOW TRUCK TOWING

Preparation

SPECIAL SERVICE TOOLS

The actual shapes of Kent-Moore tools may differ from those of special service tools illustrated here.

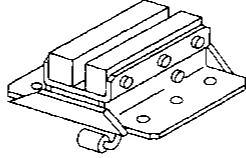
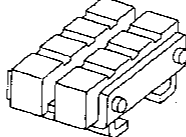
Tool number (Kent-Moore number) Tool name	Description	GI
LM4086-0200 (—) Board on attachment	 NT001	MA EM
LM4519-0000 (—) Safety stand attachment	 NT002	LC EC FE

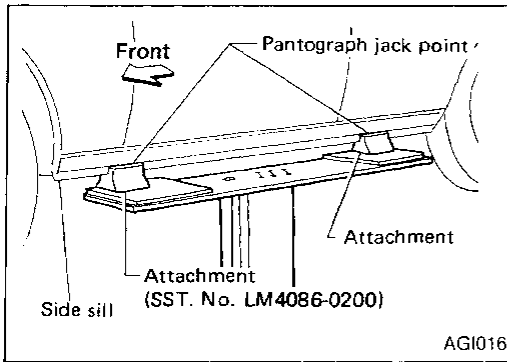

Board-on Lift

CAUTION:

Make sure vehicle is empty when lifting.

- The board-on lift attachment (LM4086-0200) set at front end of vehicle should be set on the front of the sill under the front door opening.
- Position attachments at front and rear ends of board-on lift.

GI
MA
EM
LC
EC
FE
AT
PD
FA
RA
BR
ST
RS
BT
HA
EL
IDX

Garage Jack and Safety Stand

WARNING:

- Never get under the vehicle while it is supported only by the jack. Always use safety stands to support the frame when you have to get under the vehicle.
- Place wheel chocks at both front and back of the wheels on the ground.

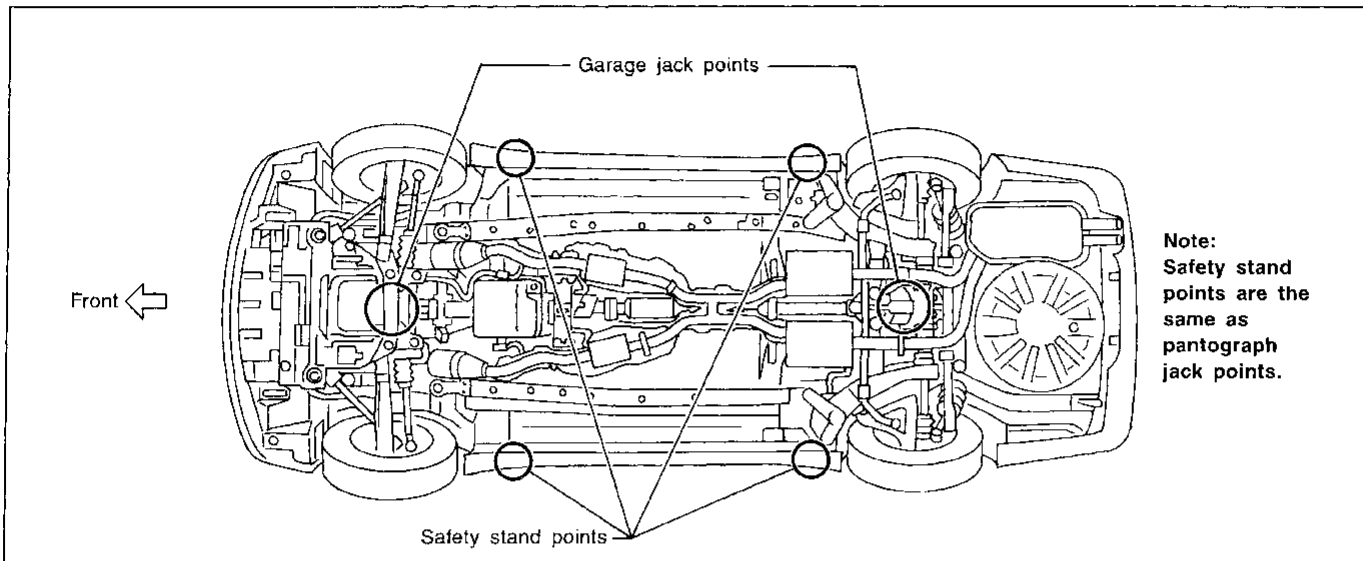

Use safety stand adapter as shown for stable support.

Attachment
SST No. LM4519-0000

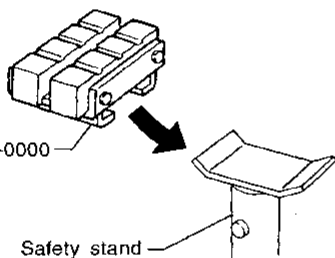

Fit the lower side sill into groove.

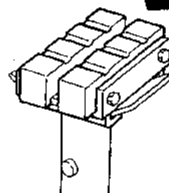

SGI945

2-pole Lift

WARNING:

When lifting the vehicle, open the lift arms as wide as possible and ensure that the front and rear of the vehicle are well balanced.

When setting the lift arm, do not allow the arm to contact the brake tubes and fuel lines.

GI
MA
EM
LC
EC
FE
AT
PD
FA

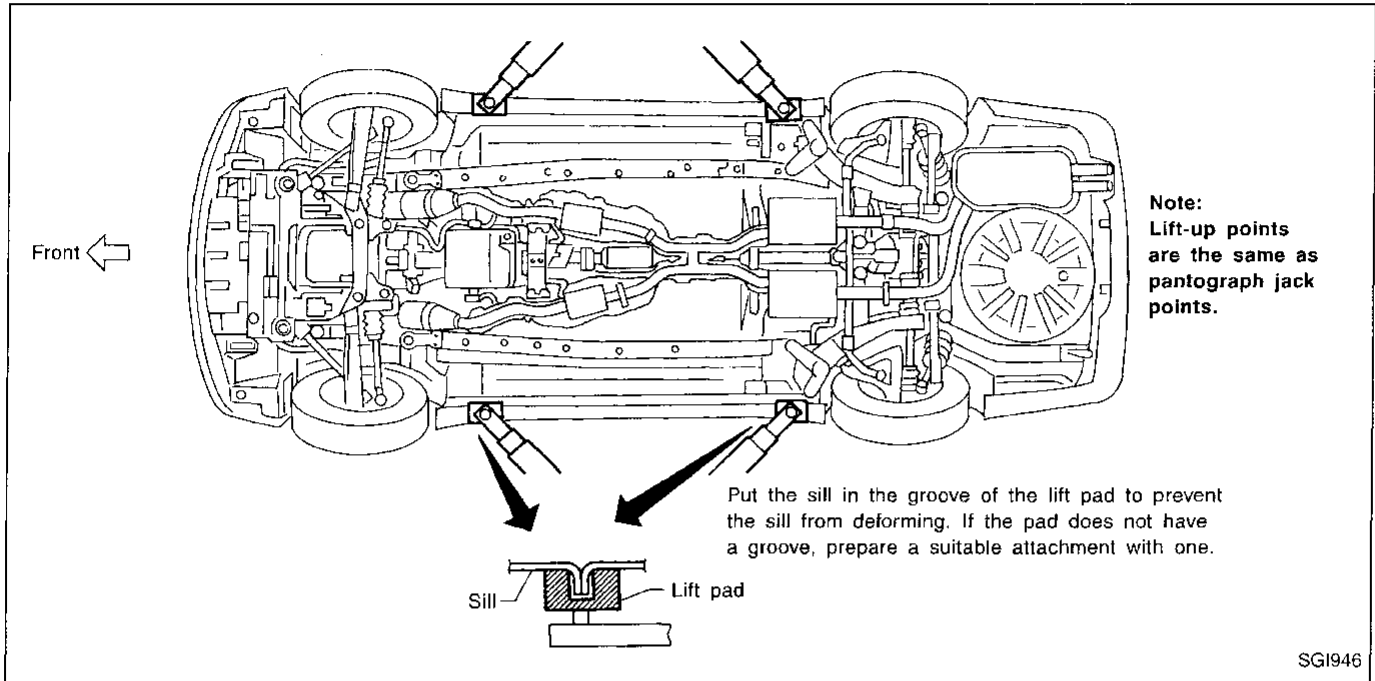

Tow Truck Towing

CAUTION:

- All applicable state or Provincial (in Canada) laws and local laws regarding the towing operation must be obeyed.
- It is necessary to use proper towing equipment to avoid possible damage to the vehicle during towing operation. Towing is in accordance with Towing Procedure Manual at dealer.
- When towing with the rear wheels on the ground, release the parking brake and move the selector lever to "N" position.
- Never tow the vehicle from the rear (i.e., backward) with four wheels on the ground as this may cause serious and expensive damage to the transmission.

RA
BR
ST
RS
BT
HA

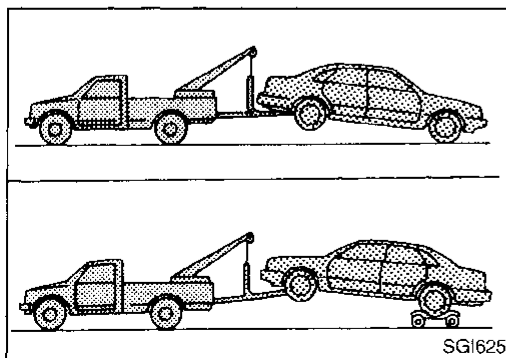

INFINITI recommends that vehicle be towed with the driving (rear) wheels off the ground as illustrated.

EL
IDX

LIFTING POINTS AND TOW TRUCK TOWING

Tow Truck Towing (Cont'd)

TOWING AN AUTOMATIC TRANSMISSION MODEL WITH FOUR WHEELS ON GROUND

Observe the following restricted towing speeds and distances.

Speed:

Below 50 km/h (30 MPH)

Distance:

Less than 65 km (40 miles)

If the speed or distance must necessarily be greater, remove the propeller shaft beforehand to prevent damage to the transmission.

TOWING WITH FRONT WHEELS RAISED (With rear wheels on ground)

- **Never tow an automatic transmission model with front wheels raised (with rear wheels on ground) as this may cause serious and expensive damage to the transmission. If it is necessary to tow it with front wheels raised, always use a towing dolly under the rear wheels.**

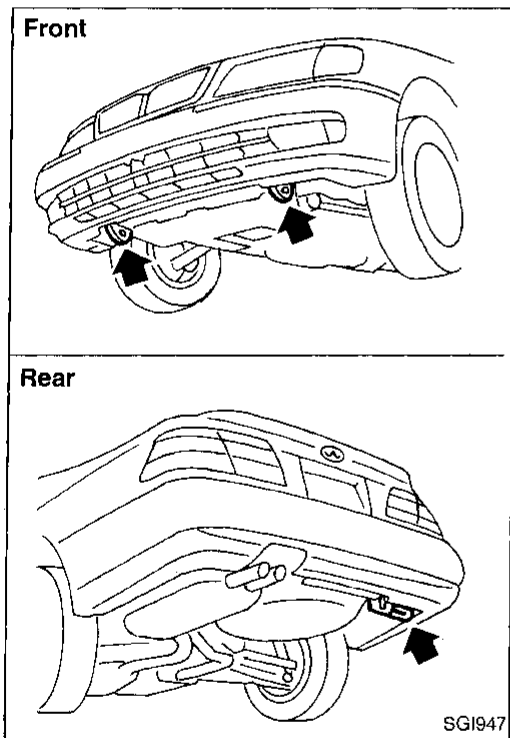

TOWING POINT

- Use the towing hooks **only**, not other parts of the vehicle. Otherwise, the vehicle body will be damaged.
- Use the towing hooks **only** to free a vehicle stuck in sand, snow, mud, etc. **Never** tow the vehicle a long distance using only the towing hooks.
- The towing hook is under tremendous force when used to free a stuck vehicle. Always pull the cable straight out from the front or rear of the vehicle. **Never** pull on the hook at a sideways angle.

WARNING:

Do not allow anyone to stand near the towing line during this operation.

TIGHTENING TORQUE OF STANDARD BOLTS

Grade	Bolt size	Bolt diameter* mm	Pitch mm	Tightening torque (Without lubricant)							
				Hexagon head bolt				Hexagon flange bolt			
				N·m	kg·m	ft·lb	in·lb	N·m	kg·m	ft·lb	in·lb
4T	M6	6.0	1.0	5.1	0.52	3.8	45.1	6.1	0.62	4.5	53.8
	M8	8.0	1.25	13	1.3	9	—	15	1.5	11	—
			1.0	13	1.3	9	—	16	1.6	12	—
	M10	10.0	1.5	25	2.5	18	—	29	3.0	22	—
			1.25	25	2.6	19	—	30	3.1	22	—
	M12	12.0	1.75	42	4.3	31	—	51	5.2	38	—
1.25			46	4.7	34	—	56	5.7	41	—	
M14	14.0	1.5	74	7.5	54	—	88	9.0	65	—	
7T	M6	6.0	1.0	8.4	0.86	6.2	74.6	10	1.0	7	87
	M8	8.0	1.25	21	2.1	15	—	25	2.5	18	—
			1.0	22	2.2	16	—	26	2.7	20	—
	M10	10.0	1.5	41	4.2	30	—	48	4.9	35	—
			1.25	43	4.4	32	—	51	5.2	38	—
	M12	12.0	1.75	71	7.2	52	—	84	8.6	62	—
1.25			77	7.9	57	—	92	9.4	68	—	
M14	14.0	1.5	127	13.0	94	—	147	15.0	108	—	
9T	M6	6.0	1.0	12	1.2	9	—	15	1.5	11	—
	M8	8.0	1.25	29	3.0	22	—	35	3.6	26	—
			1.0	31	3.2	23	—	37	3.8	27	—
	M10	10.0	1.5	59	6.0	43	—	70	7.1	51	—
			1.25	62	6.3	46	—	74	7.5	54	—
	M12	12.0	1.75	98	10.0	72	—	118	12.0	87	—
1.25			108	11.0	80	—	137	14.0	101	—	
M14	14.0	1.5	177	18.0	130	—	206	21.0	152	—	

1. Special parts are excluded.
2. This standard is applicable to bolts having the following marks embossed on the bolt head.

Grade	Mark
4T	4
7T	7
9T	9

* : Nominal diameter

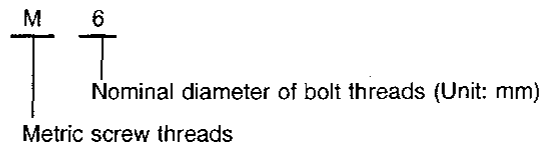

SAE J1930 TERMINOLOGY LIST

SAE J1930 Terminology List

All emission related terms used in this publication in accordance with SAE J1930 are listed. Accordingly, new terms, new acronyms/abbreviations and old terms are listed in the following chart.

***: Not applicable

NEW TERM	NEW ACRONYM / ABBREVIATION	OLD TERM
Air cleaner	ACL	Air cleaner
Barometric pressure	BARO	***
Barometric pressure sensor-BCDD	BAROS-BCDD	BCDD
Camshaft position	CMP	***
Camshaft position sensor	CMPS	Crank angle sensor
Canister	***	Canister
Carburetor	CARB	Carburetor
Charge air cooler	CAC	Intercooler
Closed loop	CL	Closed loop
Closed throttle position switch	CTP switch	Idle switch
Clutch pedal position switch	CPP switch	Clutch switch
Continuous fuel injection system	CFI system	***
Continuous trap oxidizer system	CTOX system	***
Crankshaft position	CKP	***
Crankshaft position sensor	CKPS	***
Data link connector	DLC	***
Data link connector for CONSULT	DLC for CONSULT	Diagnostic connector for CONSULT
Diagnostic test mode	DTM	Diagnostic mode
Diagnostic test mode selector	DTM selector	Diagnostic mode selector
Diagnostic test mode I	DTM I	Mode I
Diagnostic test mode II	DTM II	Mode II
Diagnostic trouble code	DTC	Malfunction code
Direct fuel injection system	DFI system	***
Distributor ignition system	DI system	Ignition timing control
Early fuel evaporation-mixture heater	EFE-mixture heater	Mixture heater
Early fuel evaporation system	EFE system	Mixture heater control
Electrically erasable programmable read only memory	EEPROM	***
Electronic ignition system	EI system	Ignition timing control
Engine control	EC	***
Engine control module	ECM	ECCS control unit
Engine coolant temperature	ECT	Engine temperature
Engine coolant temperature sensor	ECTS	Engine temperature sensor
Engine modification	EM	***
Engine speed	RPM	Engine speed
Erasable programmable read only memory	EPROM	***
Evaporative emission canister	EVAP canister	Canister

SAE J1930 TERMINOLOGY LIST

SAE J1930 Terminology List (Cont'd)

***: Not applicable

NEW TERM	NEW ACRONYM / ABBREVIATION	OLD TERM	
Evaporative emission system	EVAP system	Evaporative emission control system	
Exhaust gas recirculation valve	EGR valve	EGR valve	GI
Exhaust gas recirculation control-BPT valve	EGRC-BPT valve	BPT valve	
Exhaust gas recirculation control-solenoid valve	EGRC-solenoid valve	EGR control solenoid valve	MA
Exhaust gas recirculation temperature sensor	EGRT sensor	Exhaust gas temperature sensor	
EGR temperature sensor			EM
Flash electrically erasable programmable read only memory	FEEPROM	***	
Flash erasable programmable read only memory	FEPRM	***	LC
Flexible fuel sensor	FFS	***	
Flexible fuel system	FF system	***	EC
Fuel pressure regulator	***	Pressure regulator	
Fuel pressure regulator control solenoid valve	***	PRVR control solenoid valve	FE
Fuel trim	FT	***	
Heated Oxygen sensor	HO2S	Exhaust gas sensor	AT
Idle air control system	IAC system	Idle speed control	
Idle air control valve-air regulator	IACV-air regulator	Air regulator	PD
Idle air control valve-auxiliary air control valve	IACV-AAC valve	Auxiliary air control (AAC) valve	
Idle air control valve-FICD solenoid valve	IACV-FICD solenoid valve	FICD solenoid valve	FA
Idle air control valve-idle up control solenoid valve	IACV-idle up control solenoid valve	Idle up control solenoid valve	RA
Idle speed control-FI pot	ISC-FI pot	FI pot	
Idle speed control system	ISC system	***	BR
Ignition control	IC	***	
Ignition control module	ICM	***	ST
Indirect fuel injection system	IFI system	***	
Intake air	IA	Air	
Intake air temperature sensor	IAT sensor	Air temperature sensor	RS
Knock	***	Detonation	
Knock sensor	KS	Detonation sensor	BT
Malfunction indicator lamp	MIL	Check engine light	
Manifold absolute pressure	MAP	***	HA
Manifold absolute pressure sensor	MAPS	***	
Manifold differential pressure	MDP	***	EL
Manifold differential pressure sensor	MDPS	***	

IDX

SAE J1930 TERMINOLOGY LIST

SAE J1930 Terminology List (Cont'd)

***: Not applicable

NEW TERM	NEW ACRONYM / ABBREVIATION	OLD TERM
Manifold surface temperature	MST	***
Manifold surface temperature sensor	MSTS	***
Manifold vacuum zone	MVZ	***
Manifold vacuum zone sensor	MVZS	***
Mass air flow sensor	MAFS	Air flow meter
Mixture control solenoid valve	MC solenoid valve	Air-fuel ratio control solenoid valve
Multiport fuel injection System	MFI system	Fuel injection control
Neutral position switch	***	Neutral switch
Nonvolatile random access memory	NVRAM	***
On board diagnostic system	OBD system	Self-diagnosis
Open loop	OL	Open loop
Oxidation catalyst	OC	Catalyst
Oxidation catalytic converter system	OC system	***
Oxygen sensor	O2S	Exhaust gas sensor
Park position switch	***	Park switch
Park/neutral position switch	PNP switch	Park/neutral switch
Periodic trap oxidizer system	PTOX system	***
Positive crankcase ventilation	PCV	Positive crankcase ventilation
Positive crankcase ventilation valve	PCV valve	PCV valve
Powertrain control module	PCM	***
Programmable read only memory	PROM	***
Pulsed secondary air injection control solenoid valve	PAIRC solenoid valve	AIV control solenoid valve
Pulsed secondary air injection system	PAIR system	Air induction valve (AIV) control
Pulsed secondary air injection valve	PAIR valve	Air induction valve
Random access memory	RAM	***
Read only memory	ROM	***
Scan tool	ST	***
Secondary air injection pump	AIR pump	***
Secondary air injection system	AIR system	***
Sequential multiport fuel injection system	SFI system	Sequential fuel injection
Service reminder indicator	SRI	***
Simultaneous multiport fuel injection system	***	Simultaneous fuel injection
Smoke puff limiter system	SPL system	***
Supercharger	SC	***
Supercharger bypass	SCB	***
System readiness test	SRT	***
Thermal vacuum valve	TVV	Thermal vacuum valve
Three way catalyst	TWC	Catalyst
Three way catalytic converter system	TWC system	***
Three way+oxidation catalyst	TWC+OC	Catalyst

SAE J1930 TERMINOLOGY LIST

SAE J1930 Terminology List (Cont'd)

***: Not applicable

NEW TERM	NEW ACRONYM / ABBREVIATION	OLD TERM
Three way+oxidation catalytic converter system	TWC+OC system	***
Throttle body	TB	Throttle chamber SPI body
Throttle body fuel injection system	TBI system	Fuel injection control
Throttle position	TP	Throttle position
Throttle position sensor	TPS	Throttle sensor
Throttle position switch	TP switch	Throttle switch
Torque converter clutch solenoid valve	TCC solenoid valve	Lock-up cancel solenoid Lock-up solenoid
Turbocharger	TC	Turbocharger
Vehicle speed sensor	VSS	Vehicle speed sensor
Volume air flow sensor	VAFS	Air flow meter
Warm up oxidation catalyst	WU-OC	Catalyst
Warm up oxidation catalytic converter system	WU-OC system	***
Warm up three way catalyst	WU-TWC	Catalyst
Warm up three way catalytic converter system	WU-TWC system	***
Wide open throttle position switch	WOTP switch	Full switch

GI

MA

EM

LC

EC

FE

AT

PD

FA

RA

BR

ST

RS

BT

HA

EL

IDX