

PROPELLER SHAFT & DIFFERENTIAL CARRIER

SECTION PD

GI

MA

EM

LC

EC

FE

AT

PD

FA

RA

BR

ST

RS

BT

HA

EL

ICX

CONTENTS

PREPARATION	2	DISASSEMBLY	12
Special Service Tools.....	2	Pre-inspection.....	12
Commercial Service Tool.....	4	Differential Carrier.....	12
PROPELLER SHAFT	5	Differential Case.....	14
On-vehicle Service.....	5	INSPECTION	16
Removal.....	5	Contact Surfaces.....	16
Installation.....	6	Bearing.....	16
Inspection.....	7	ADJUSTMENT	17
Disassembly.....	7	Differential Case.....	17
Assembly.....	8	Side Bearing Preload.....	18
ON-VEHICLE SERVICE/REMOVAL AND		Pinion Gear Height and Pinion Bearing Preload.....	19
INSTALLATION	9	Tooth Contact.....	24
Front Oil Seal Replacement.....	9	ASSEMBLY	25
Side Oil Seal Replacement.....	9	SERVICE DATA AND SPECIFICATIONS (SDS)	29
Removal.....	10	Propeller Shaft.....	29
Installation.....	10	Final Drive.....	29
FINAL DRIVE	11		

PREPARATION

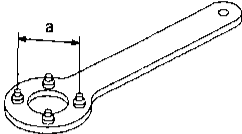
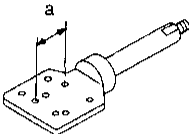
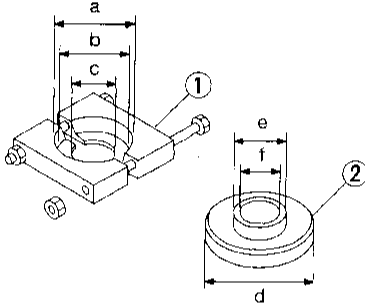
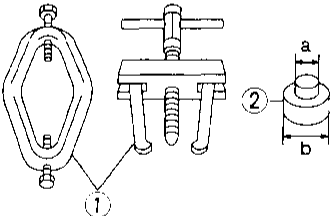
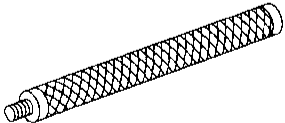
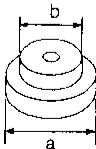

Special Service Tools

The actual shapes of Kent-Moore tools may differ from those of special service tools illustrated here.

Tool number (Kent-Moore No.) Tool name	Description	
(J34311) Drive pinion flange wrench		Removing and installing propeller shaft lock nut, and drive pinion lock nut. a: 81.25 mm (3.1988 in)
KV38100800 (—) Equivalent tool (J25604-01) Differential attachment		Mounting final drive (To use, make a new hole.) a: 156 mm (6.14 in)
ST3090S000 (—) Drive pinion rear inner race puller set ① ST30031000 (J22912-01) Puller ② ST30901000 (—) Equivalent tool (J26010-01) Base		Removing and installing drive pinion rear cone a: 90 mm (3.54 in) dia. b: 80 mm (3.15 in) dia. c: 50 mm (1.97 in) dia. d: 79 mm (3.11 in) dia. e: 45 mm (1.77 in) dia. f: 35 mm (1.38 in) dia.
ST3306S001 (—) Differential side bearing puller set ① ST3305S001 (—) Equivalent tool (J22888-20) Body ② ST33061000 (J8107-2) Equivalent tool (J26010-01) Adapter		Removing and installing differential side bear- ing inner cone a: 28.5 mm (1.122 in) dia. b: 38 mm (1.50 in) dia.
ST30611000 (J25742-1) Drift		Installing pinion rear bearing outer race (Use with ST30613000)
ST30613000 (J25742-3) Drift		Installing pinion front bearing outer race (Use with ST30611000) a: 72 mm (2.83 in) dia. b: 48 mm (1.89 in) dia.

PREPARATION

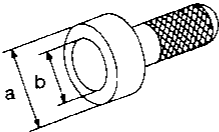
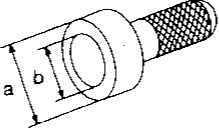
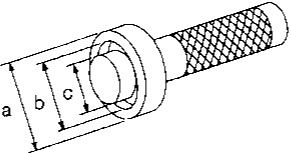
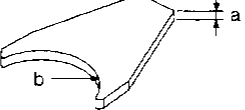
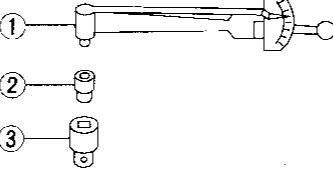
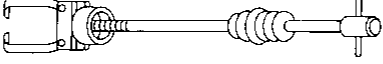
Special Service Tools (Cont'd)

Tool number (Kent-Moore No.) Tool name	Description	Installing side oil seal	GI
KV38100200 (J26233) Gear carrier side oil seal drift	NT115	 <p>a: 65 mm (2.56 in) dia. b: 49 mm (1.93 in) dia.</p>	MA
KV38100500 (—) Gear carrier front oil seal drift	NT115	 <p>a: 85 mm (3.35 in) dia. b: 60 mm (2.36 in) dia.</p>	EM
KV38100300 (J25523) Differential side bearing inner cone	NT085	 <p>a: 54 mm (2.13 in) dia. b: 46 mm (1.81 in) dia. c: 32 mm (1.26 in) dia.</p>	LC
KV38100600 (J25267) Side bearing spacer drift	NT528	 <p>a: 8 mm (0.31 in) b: R42.5 mm (1.673 in)</p>	EC
ST3127S000 (See J25765-A) Preload gauge ① GG91030000 (J25765) Torque wrench ② HT62940000 (—) Socket adapter ③ HT62900000 (—) Socket adapter	NT124		FE
HA72400000 (—) Slide hammer	NT125		AT
(J34309) Differential shim selector	NT134		PD
		Removing differential case assembly	FA
		Adjusting bearing preload and gear height	RA
			BR
			ST
			RS
			BT
			EA
			EL
			DX

PREPARATION
Special Service Tools (Cont'd)

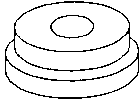
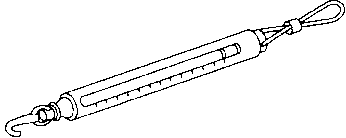
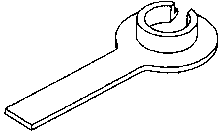
Tool number (Kent-Moore No.) Tool name	Description
(J25269-4) Side bearing discs (2 Req'd)	<div style="text-align: right;">Selecting pinion height adjusting washer</div> <div style="text-align: center;">  </div> <div>NT136</div>
(J8129) Spring gauge	<div style="text-align: right;">Measuring carrier turning torque</div> <div style="text-align: center;">  </div> <div>NT127</div>
KV38107900 (J39352) Side oil seal protector	<div style="text-align: right;">Installing final drive side flange</div> <div style="text-align: center;">  </div> <div>NT129</div>

Commercial Service Tool

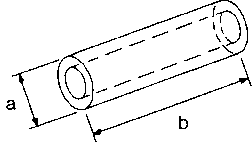
Tool name	Description
Drift	<div style="text-align: right;">Installing pinion rear bearing outer race</div> <div style="text-align: center;">  </div> <div style="display: flex; justify-content: space-between; align-items: flex-start;"> <div>NT131</div> <div style="text-align: right;"> <p>a: 89 mm (3.50 in) dia.</p> <p>b: 200 mm (7.87 in)</p> </div> </div>

PROPELLER SHAFT

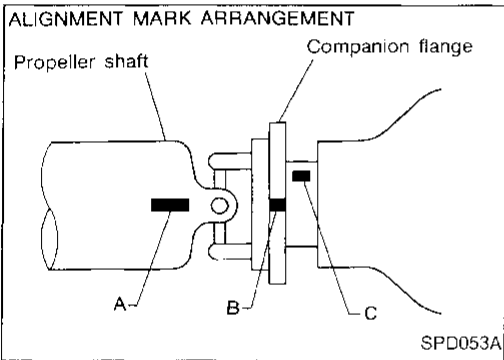
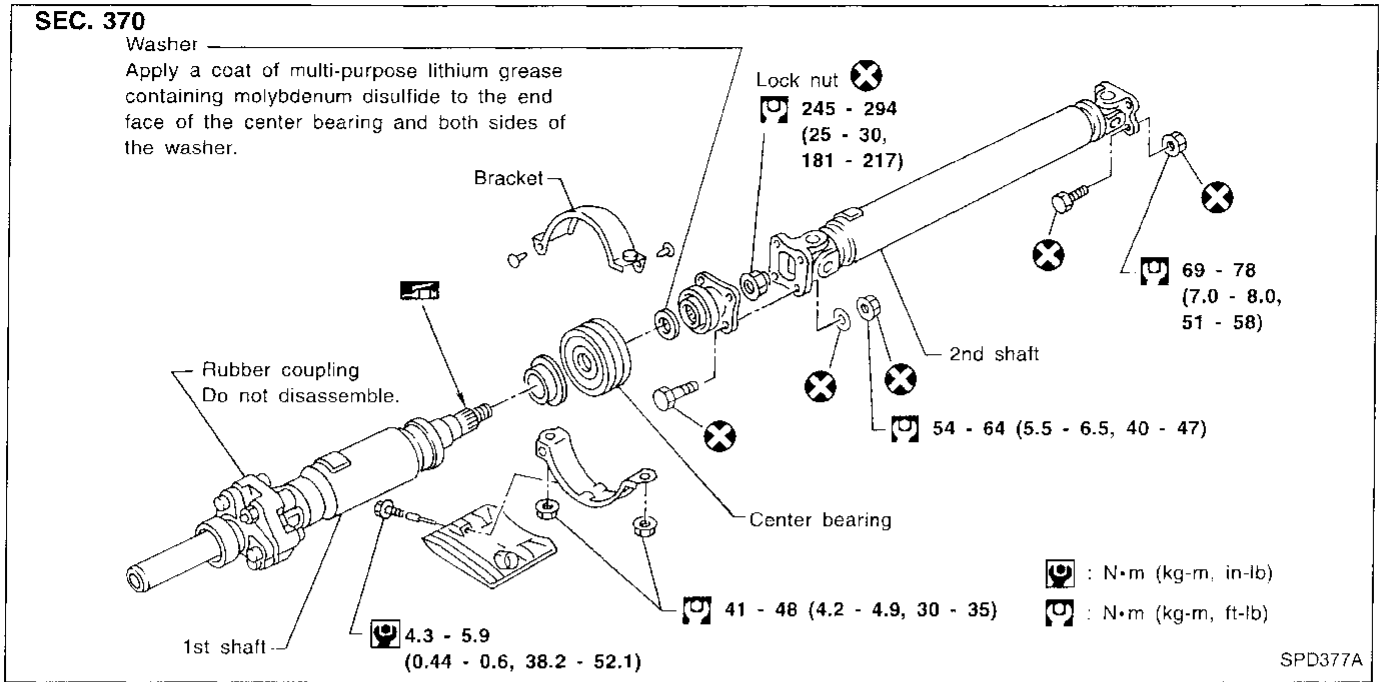

On-vehicle Service

PROPELLER SHAFT VIBRATION

If vibration is present at high speed, check mounting between propeller shaft and companion flange.

Make sure alignment marks A and B are located as close to each other as possible.

If not, change mounting as indicated in "Installation".

APPEARANCE CHECKING

- Inspect propeller shaft tube surface for dents or cracks. If damaged, replace propeller shaft assembly.
- If center bearing is noisy or damaged, replace center bearing.

Removal

Before removing propeller shaft, check marks on bolts to reuse them in the same position.

If propeller shaft is replaced with a new one, replace all bolts with "9" bolts. Do not use "A", "B" or "C" bolts.

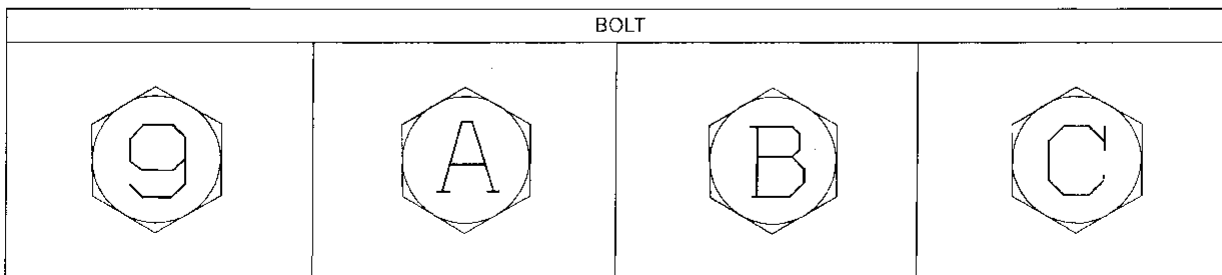

SPD378A

PROPELLER SHAFT

Removal (Cont'd)

- Draw out propeller shaft from transmission and plug up rear end of transmission rear extension housing.

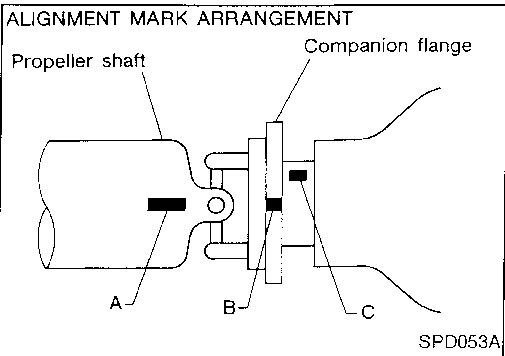
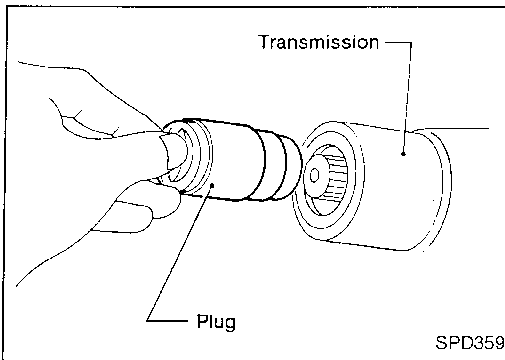

Installation

If companion flange has been removed, put new alignment marks B and C on it. Then reassemble using the following procedure. (Perform step 4 when final drive and propeller shaft are separated from each other. Also perform step 4 when either of these parts is replaced with a new one.)

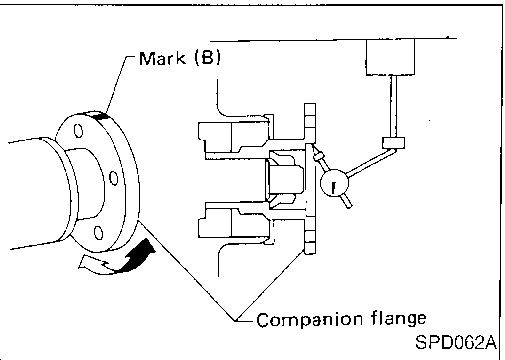

1. Erase original marks B and C from companion flange with suitable solvent.
2. Mark (B)
 - a. Measure companion flange vertical runout.
 - b. Determine the position where maximum runout is read on dial gauge. Put mark (shown by B in figure at left) on flange perimeter corresponding to maximum runout position.

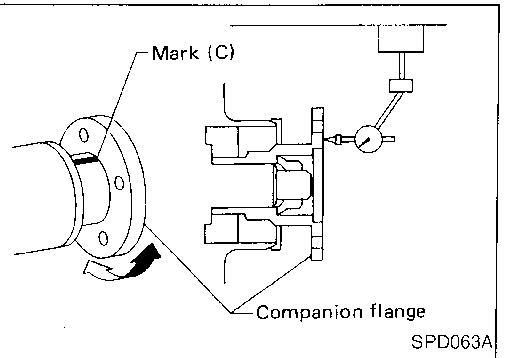

3. Mark (C)
 - a. Measure companion flange surface runout.
 - b. Determine the position where maximum runout is read on dial gauge. Put mark (shown by C in figure at left) on flange perimeter corresponding to maximum runout position.

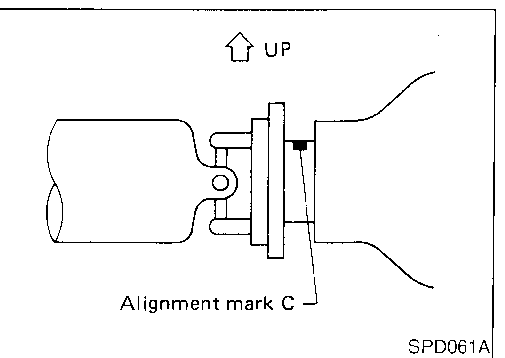

4. Position companion flange and propeller shaft using alignment marks A and B. Set the marks A and B as close to each other as possible. Temporarily attach bolts and nuts.
5. Press down propeller shaft with alignment mark C facing upward. Then tighten the lower nut to specified torque.
6. Tighten remaining nuts to specified torque.

PROPELLER SHAFT

Installation (Cont'd)

CENTER BEARING BRACKET INSTALLATION

- Position the bearing cushion overlap as illustrated at left.

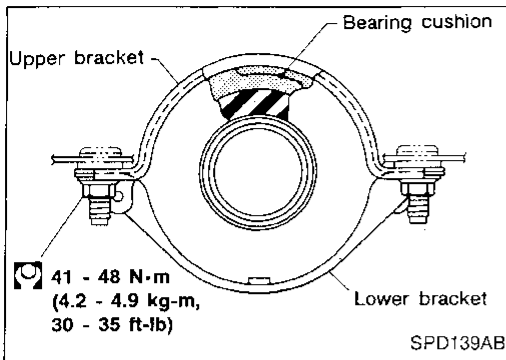

Inspection

- Inspect propeller shaft runout. If runout exceeds specifications, replace propeller shaft assembly.
Runout limit: 0.6 mm (0.024 in)

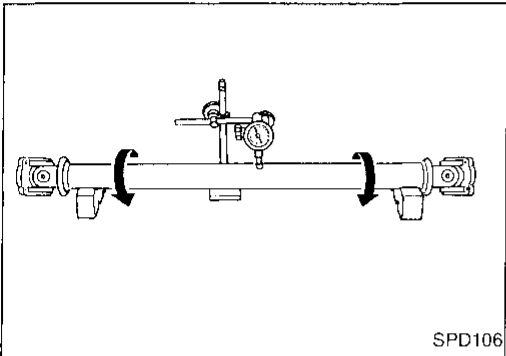

- Inspect journal axial play. If the play exceeds specifications, replace propeller shaft assembly.

Journal axial play:
0 mm (0 in)

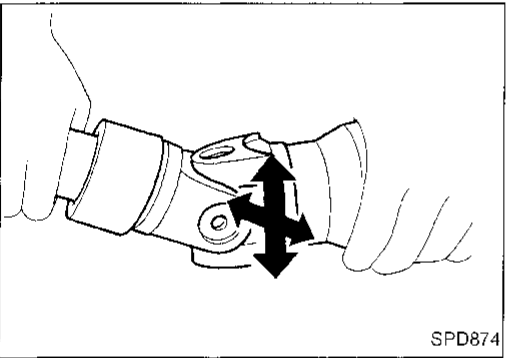

Disassembly

FRONT CENTER BEARING

1. Put matchmarks on flanges, and separate 2nd tube from 1st tube.

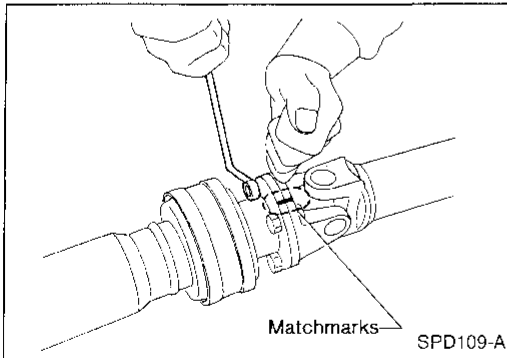

2. Put matchmarks on the flange and shaft.

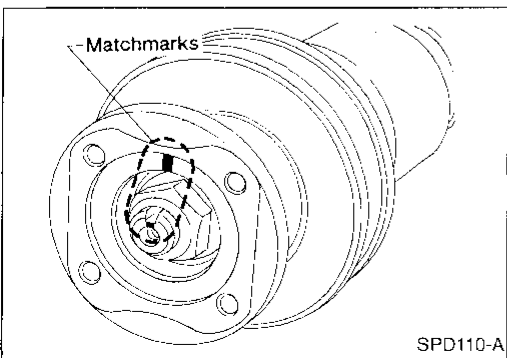

GI

MA

EV

LC

EC

FE

AT

PD

FA

PA

BR

ST

RS

BT

HA

E-

ICX

PROPELLER SHAFT

Disassembly (Cont'd)

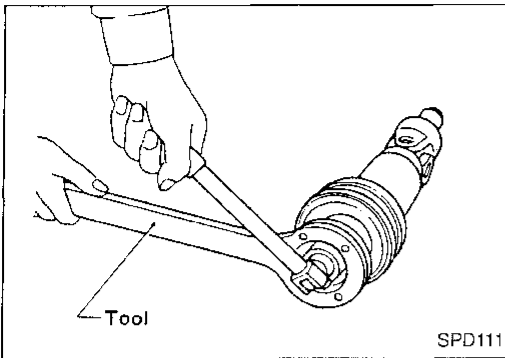

3. Remove lock nut with Tool.
Tool number: J34311

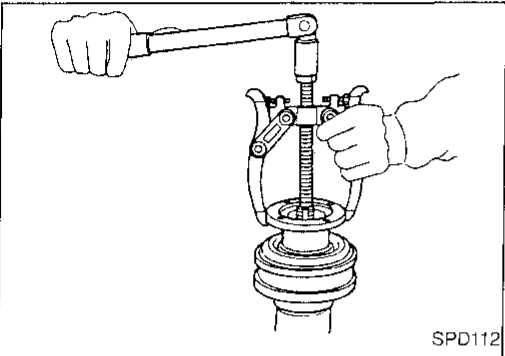

4. Remove companion flange with puller.

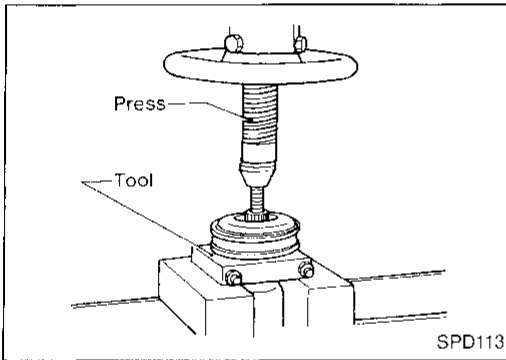

5. Remove center bearing with Tool and press.
Tool number: ST30031000 (J22912-01)

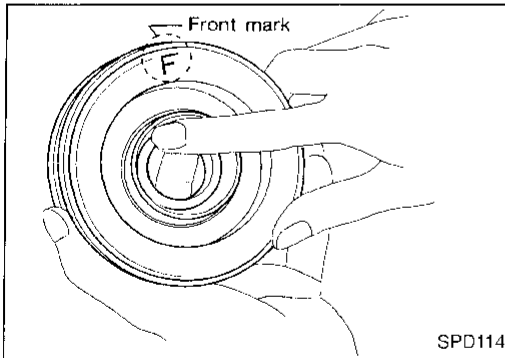

Assembly

CENTER BEARING

- When installing center bearing, position the "F" mark on center bearing toward front of vehicle.
- Apply a coat of grease to the end face of center bearing and both sides of washer.
Use multi-purpose lithium grease that contains molybdenum disulfide.

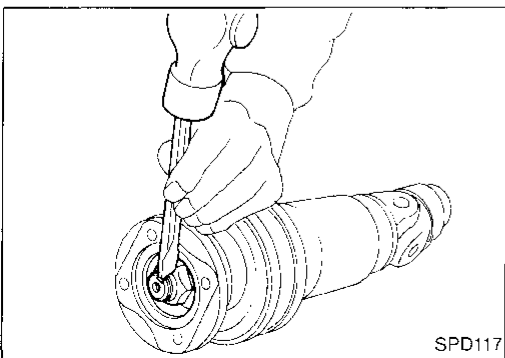

- Stake the nut. Always use new one.
- Align matchmarks when assembling tubes.

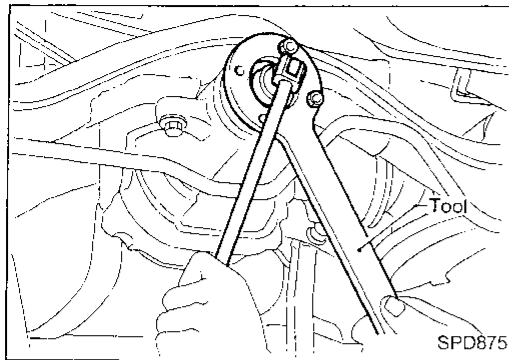

Front Oil Seal Replacement

1. Remove propeller shaft.
2. Loosen drive pinion nut with Tool.
Tool number: J34311

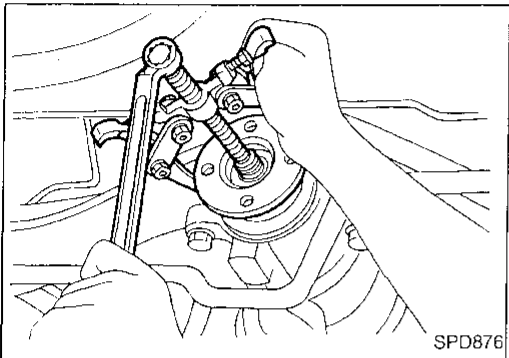

3. Remove companion flange.

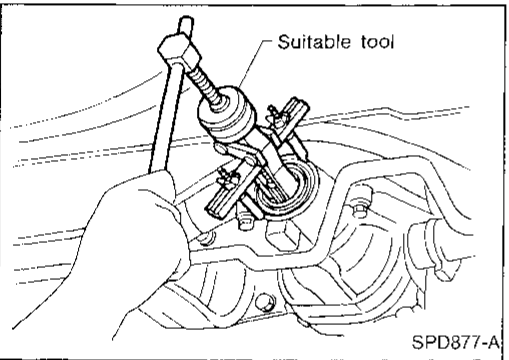

4. Remove front oil seal.

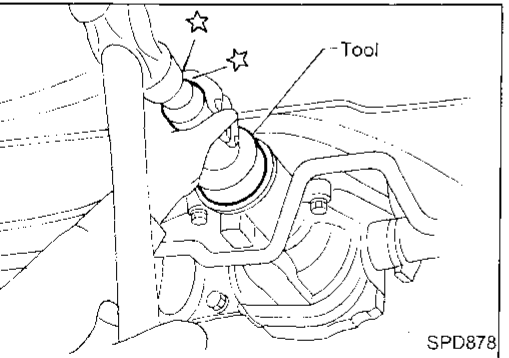

5. Apply multi-purpose grease to sealing lips of oil seal. Press front oil seal into carrier with Tool.
Tool number: KV38100500 (—)
6. Install companion flange and drive pinion nut.
7. Install propeller shaft.

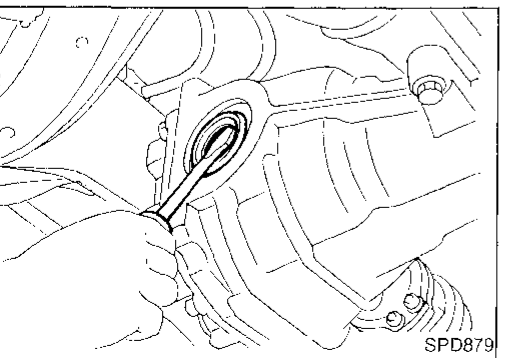

Side Oil Seal Replacement

1. Remove drive shafts.
Refer to "REAR AXLE — Drive Shaft" in RA section.
2. Remove final drive side flange.
3. Remove oil seal.

CI

MA

EM

LC

EC

FE

AT

PD

FA

RA

BR

ST

RS

BT

HA

EL

IDX

ON-VEHICLE SERVICE/REMOVAL AND INSTALLATION

Side Oil Seal Replacement (Cont'd)

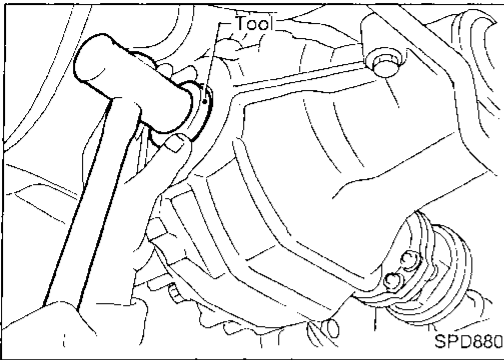

4. Apply multi-purpose grease to sealing lips of oil seal. Press-fit oil seal into carrier with Tool.

Tool number: KV38100200 (J26233)

5. Install side flange and drive shafts.

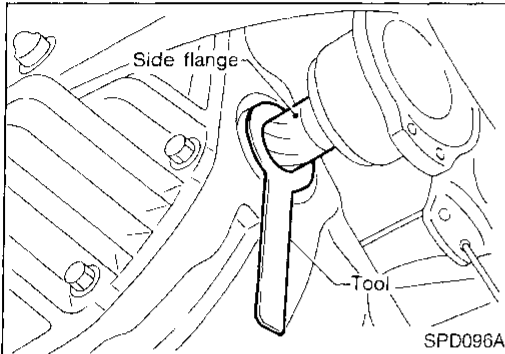

SIDE FLANGE INSTALLATION

Use Tool to prevent side oil seal from being damaged by spline portion of side flange.

Tool number: KV38107900 (J39352)

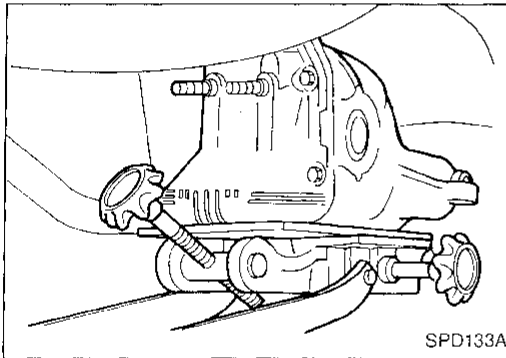

Removal

- Remove propeller shaft.

Insert plug into rear oil seal after removing propeller shaft.

- Remove drive shafts.
Refer to "Drive Shaft" of "REAR AXLE" in RA section.
- Remove TCS sensor.
- Remove nuts securing final drive rear cover to suspension member.
- Support weight of final drive using jack.
- Remove final drive mounting bolts from front of final drive.
- Move final drive forward together with jack. Remove rear cover stud bolts from suspension member.
- Pull off final drive backward together with jack.

CAUTION:

- **Be careful not to damage spline, sleeve yoke and front oil seal, when removing propeller shaft.**
- **After removal, support suspension member on a stand to prevent its insulators from being twisted or damaged.**

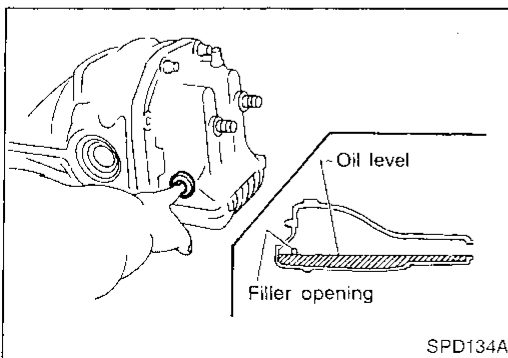

Installation

- Fill final drive with recommended gear oil.

FINAL DRIVE

SEC. 380

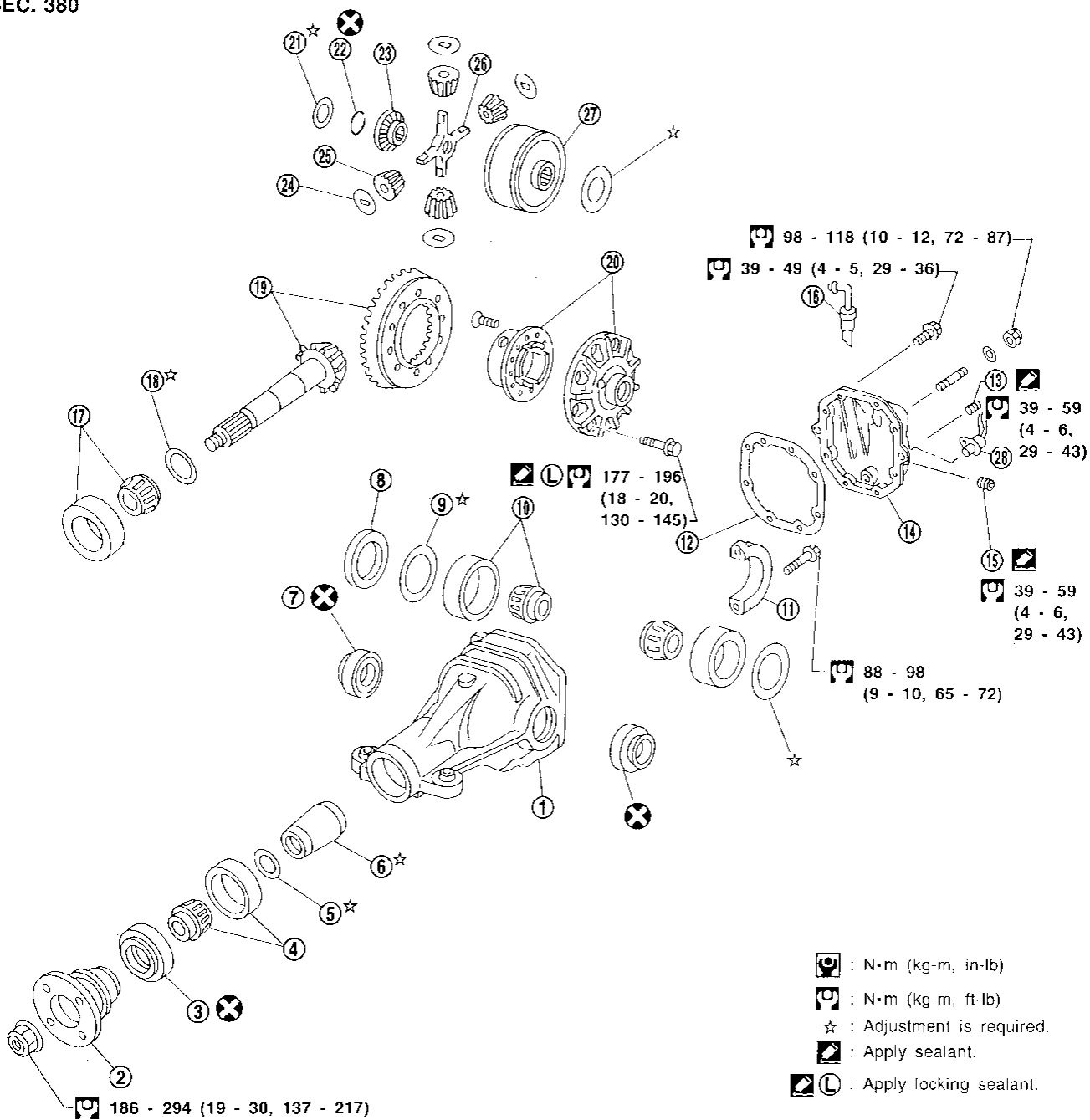

- ① Gear carrier
- ② Companion flange
- ③ Front oil seal
- ④ Pinion front bearing
- ⑤ Pinion bearing adjusting washer (Solid spacer)
- ⑥ Pinion bearing adjusting spacer
- ⑦ Side oil seal
- ⑧ Side bearing spacer
- ⑨ Side bearing adjusting washer
- ⑩ Side bearing

- ⑪ Bearing cap
- ⑫ Gasket
- ⑬ Drain plug
- ⑭ Rear cover
- ⑮ Filler plug
- ⑯ Breather
- ⑰ Pinion rear bearing
- ⑱ Pinion height adjusting washer
- ⑲ Hypoid gear set

- ⑳ Differential case
- ㉑ Side gear thrust washer
- ㉒ Circular clip
- ㉓ Side gear (RH)
- ㉔ Pinion mate thrust washer
- ㉕ Pinion mate gear
- ㉖ Pinion mate shaft
- ㉗ Side gear (LH) with viscous coupling
- ㉘ TCS sensor

SPD376A

DISASSEMBLY

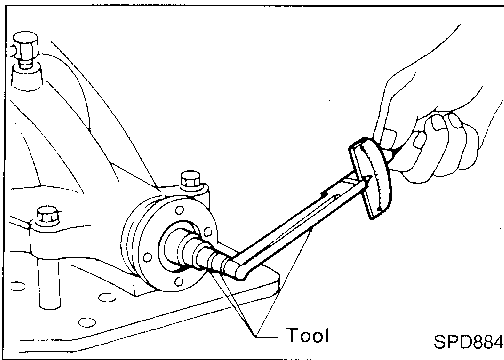

Pre-inspection

Before disassembling final drive, perform the following inspection.

- Total preload
 - 1) Turn drive pinion in both directions several times to set bearing rollers.
 - 2) Check total preload with Tool.

Tool number: ST3127S000 (See J25765-A)

Total preload:

1.4 - 3.1 N·m (14 - 32 kg·cm, 12 - 28 in·lb)

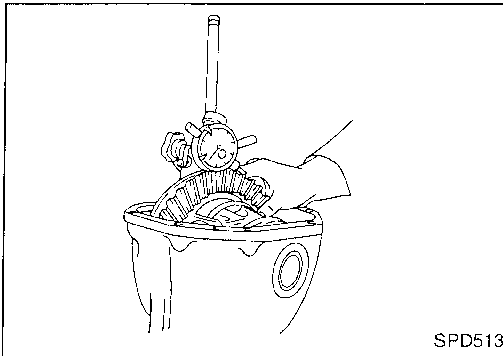

- Ring gear to drive pinion backlash
Check ring gear-to-drive pinion backlash with a dial indicator at several points.

Ring gear backlash:

0.10 - 0.15 mm (0.0039 - 0.0059 in)

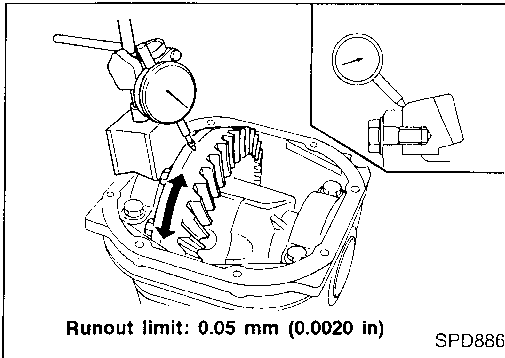

- Ring gear runout
Check runout of ring gear with a dial indicator.

Runout limit:

0.05 mm (0.0020 in)

- Tooth contact
Check tooth contact. Refer to Adjustment (PD-24).

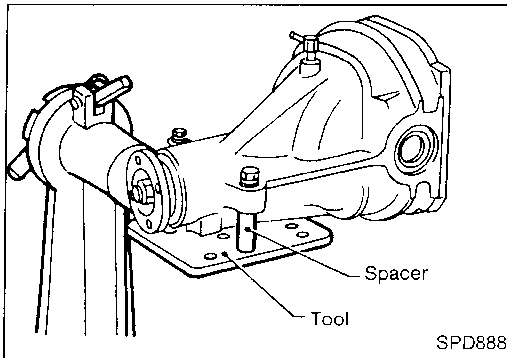

Differential Carrier

1. Using two 45 mm (1.77 in) spacers, mount carrier on Tool.

Tool number: KV38100800 (—)

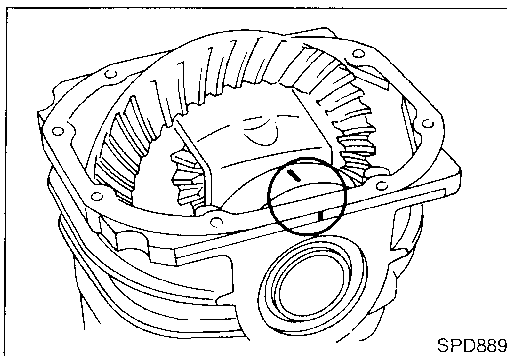

2. For proper reinstallation, paint or punch matchmarks on one side of the side bearing cap.

Bearing caps are line-board during manufacture. Replace them in their proper positions.

DISASSEMBLY

Differential Carrier (Cont'd)

3. Remove side bearing caps.

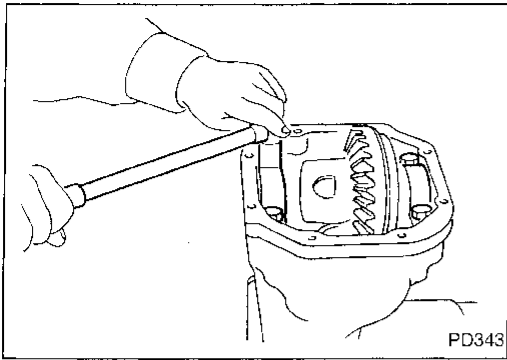

4. Lift differential case assembly out with Tool.
Tool number: HT72400000 (—)

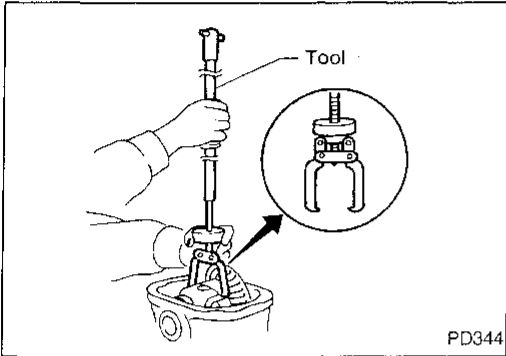

Keep the side bearing outer races together with inner cone — do not mix them up.
Also, keep side bearing spacer and adjusting shims together with bearings.

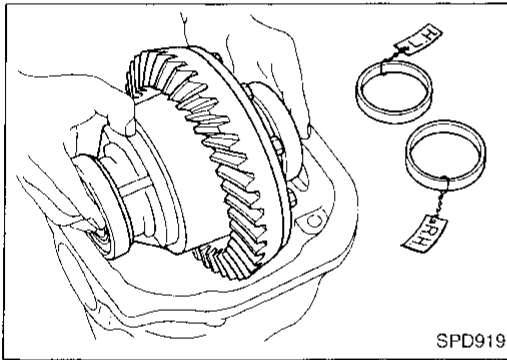

5. Loosen drive pinion nut and pull off companion flange.

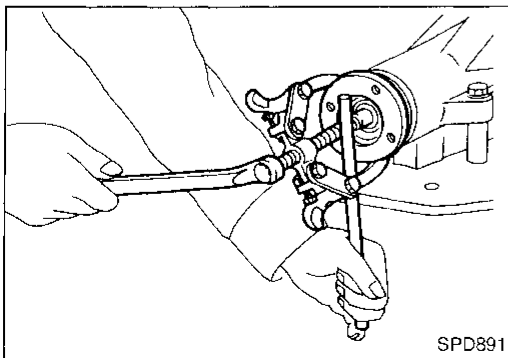
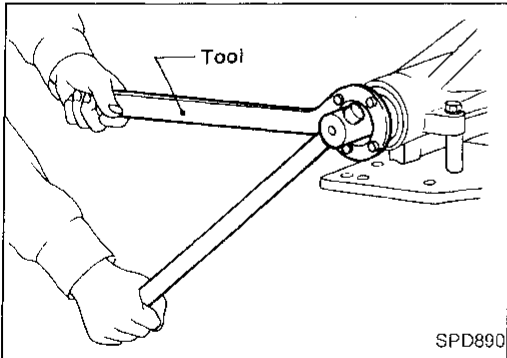

GI

MA

EM

LC

EC

FE

AT

PD

FA

RA

BR

ST

RS

BT

HA

EL

IDX

DISASSEMBLY

Differential Carrier (Cont'd)

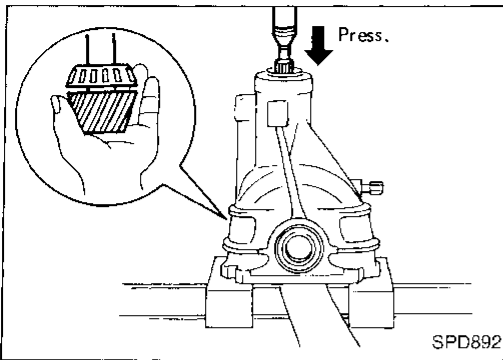

6. Take out drive pinion (together with rear bearing inner race, bearing spacer and adjusting washer).
7. Remove oil seal.
8. Remove front bearing inner race.
9. Remove side oil seal.

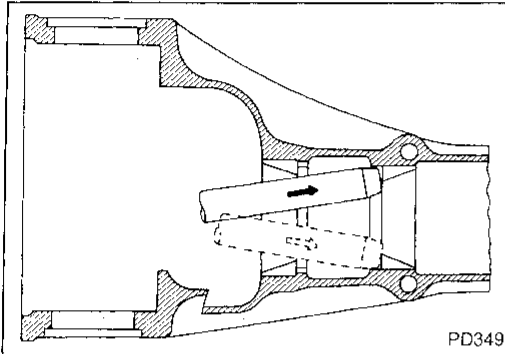

10. Remove pinion bearing outer races with a brass drift.

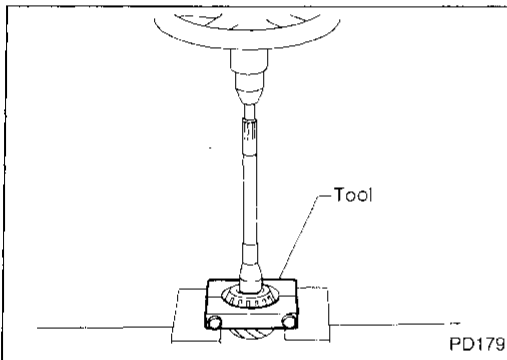

11. Remove pinion rear bearing inner race and drive pinion height adjusting washer with Tool.

Tool number:

ST30031000 (J22912-01)

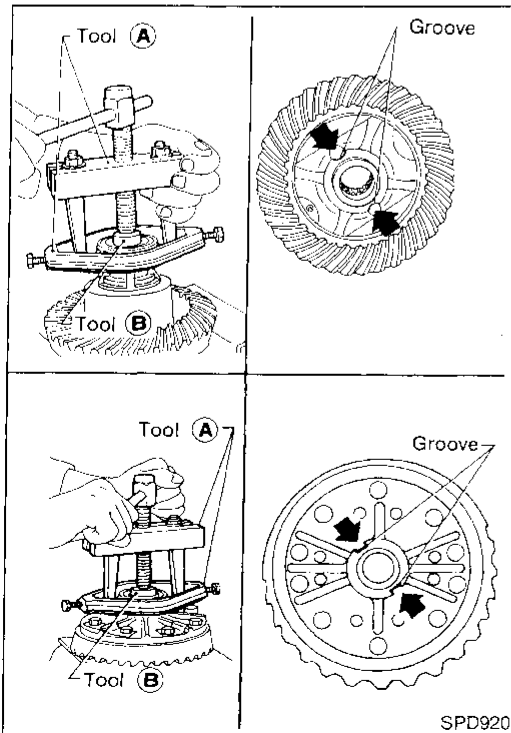

Differential Case

1. Remove side bearing inner cones.

To prevent damage to bearing, engage puller jaws in groove.

Tool number:

(A) ST3305S001 (—)

(B) ST33061000 (J8107-2)

DISASSEMBLY

Differential Case (Cont'd)

Be careful not to confuse left- and right-hand parts.

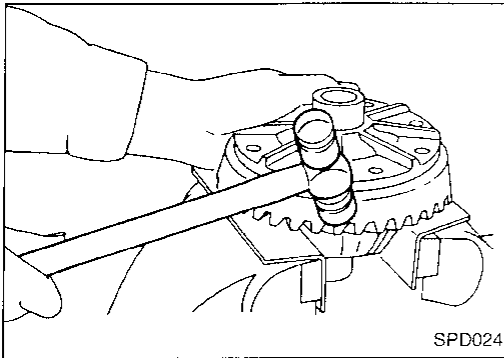
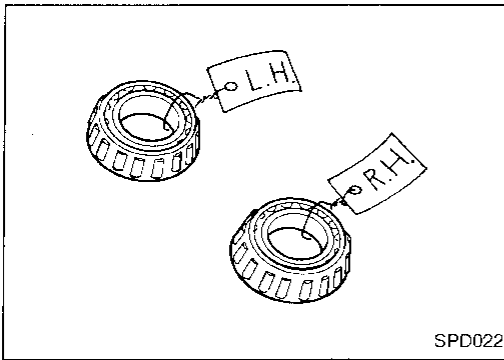

2. Loosen ring gear bolts in a criss-cross fashion.
3. Tap ring gear off the differential case with a soft hammer.
Tap evenly all around to keep ring gear from binding.

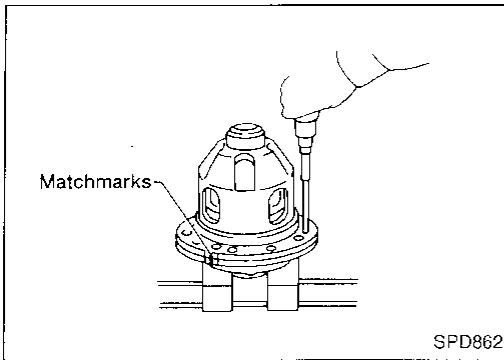

4. Loosen screws on differential cases A and B.
5. Separate differential cases A and B.

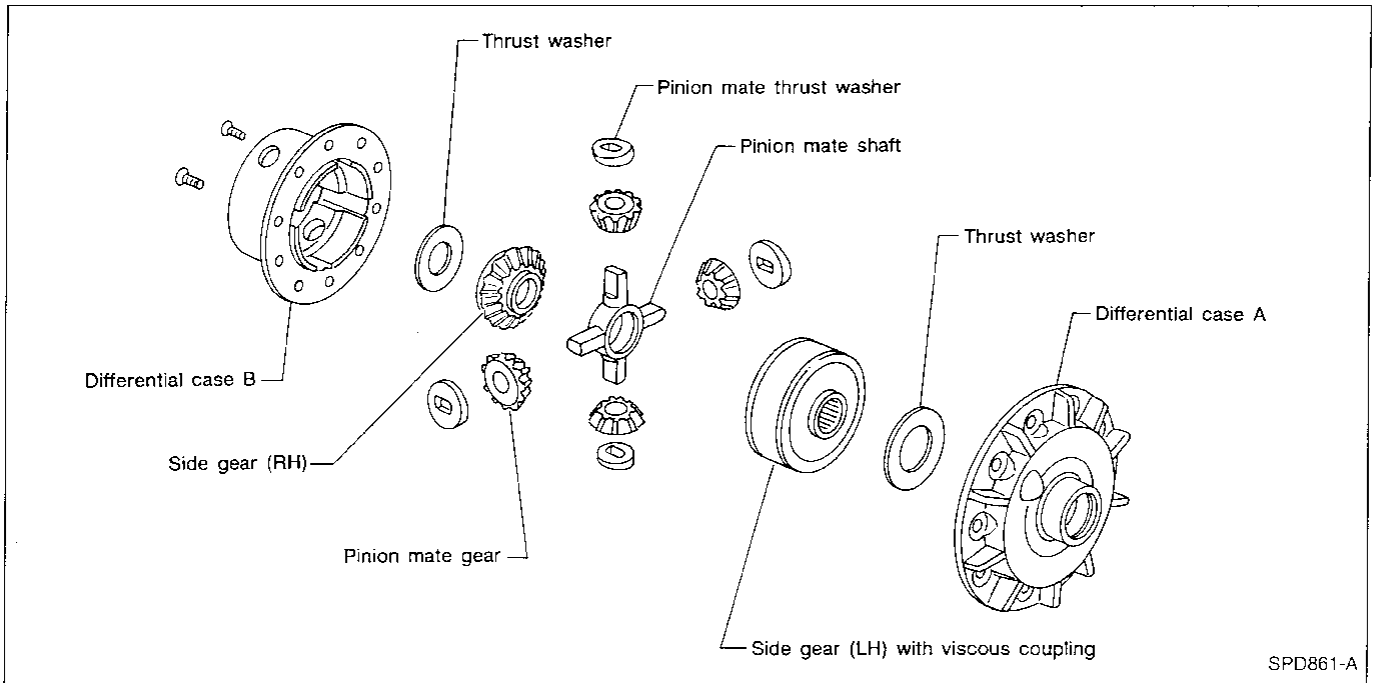

GI

MA

EM

LC

EC

FE

AT

PD

FA

RA

BR

ST

RS

BT

HA

EL

IDX

INSPECTION

Contact Surfaces

1. Clean the disassembled parts in suitable solvent and blow dry with compressed air.
2. If following surfaces are found to be burred or scratched, smooth with oil stone.
 - Differential case A
 - Differential case B
 - Side gear
 - Pinion mate gear
 - Pinion mate shaft
3. Check viscous coupling for oil leakage. If it is faulty, replace it with new one.

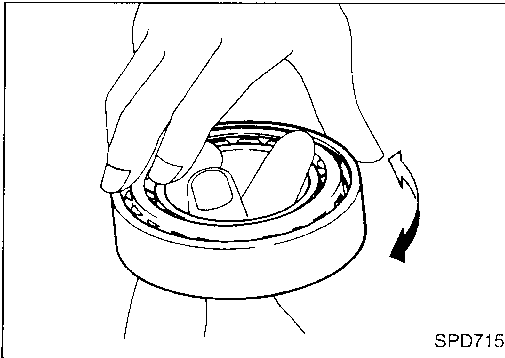

Bearing

1. Thoroughly clean bearing.
2. Check bearings for wear, scratches, pitting or flaking. Check tapered roller bearing for smooth rotation. If damaged, replace outer race and inner cone as a set.

ADJUSTMENT

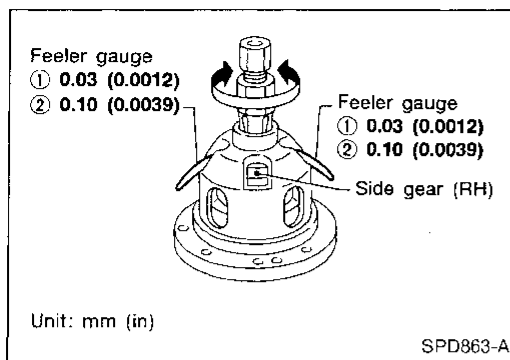

Differential Case

THRUST WASHER SELECTION

Whenever side gears or pinion mate gears are replaced, select suitable thrust washers as follows:

1. Clean side gears and pinion mate gears using white gasoline.
2. Before assembling gears, apply hypoid gear oil to frictional surfaces.
3. Install the previously removed thrust washer on right side gear. On left side gear, install a suitable thrust washer. Temporarily tighten differential cases using two screws.
4. Position differential assembly so that right side gear is on the upper side. Place two feeler gauges of 0.03 mm (0.0012 in) thickness between right side gear and thrust washer as shown.

Do not place feeler gauge at groove side of differential case.

5. Also place a 0.03 mm (0.0012 in) additional feeler gauge between right side gear and thrust washer so that it is positioned diagonal to (180° apart from) the feeler gauge described previously.
6. Rotate right side gear with a suitable tool attached to splines. If hard to rotate, replace thrust washer on left side gear with a thinner one.
7. Replace both 0.03 mm (0.0012 in) feeler gauges with 0.10 mm (0.0039 in) gauges. At this point, make sure right side gear does not rotate. If it rotates, replace thrust washer on left side gear with a thicker one to prevent rotation.
8. As explained in above example, select suitable thrust washers to ensure that:
 - a) Both side gears rotate. [0.03 mm (0.0012 in) feeler gauges are used in this case.]
 - b) Side gear is held stationary. [0.10 mm (0.0039 in) gauges are used in this case.]

CI

MA

EW

LC

EC

PE

AT

PD

FA

RA

BR

ST

RS

BT

HA

EL

ICX

ADJUSTMENT

For quiet and reliable final drive operation, the following five adjustments must be made correctly.

1. Side bearing preload
2. Pinion gear height
3. Pinion bearing preload
4. Ring gear to pinion backlash. Refer to ASSEMBLY (PD-28).
5. Ring and pinion gear tooth contact pattern

Side Bearing Preload

A selection of carrier side bearing preload shims is required for successful completion of this procedure.

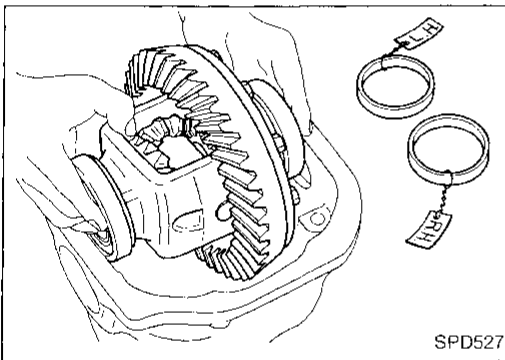

1. Make sure all parts are clean. Also, make sure the bearings are well lubricated with light oil or DEXRON™ type automatic transmission fluid.
2. Place the differential carrier, with side bearings and bearing races installed, into the final drive housing.

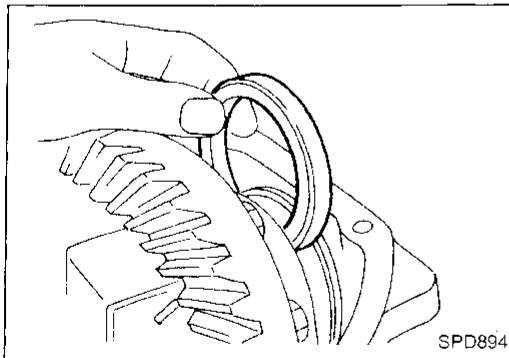

3. Put the side bearing spacer in place on the ring gear end of the carrier.

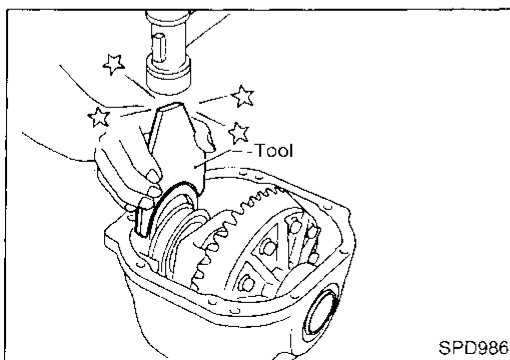

4. Use the J25267 side bearing spacer drift. Place original carrier side bearing preload shims on the carrier end, opposite the ring gear.

Tool number:
KV38100600 (J25267)

ADJUSTMENT

Side Bearing Preload (Cont'd)

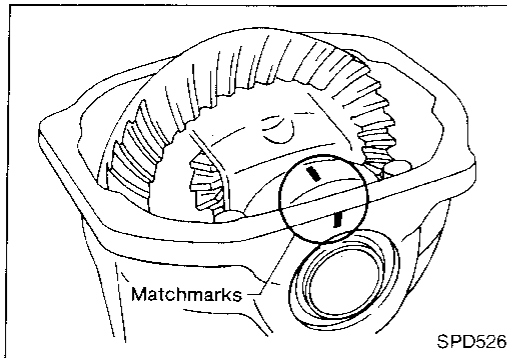

5. Install the side bearing caps in their correct locations and torque the bearing cap retaining bolts.

Specification:

88 - 98 N-m (9 - 10 kg-m, 65 - 72 ft-lb)

6. Turn the carrier several times to seat the bearings.

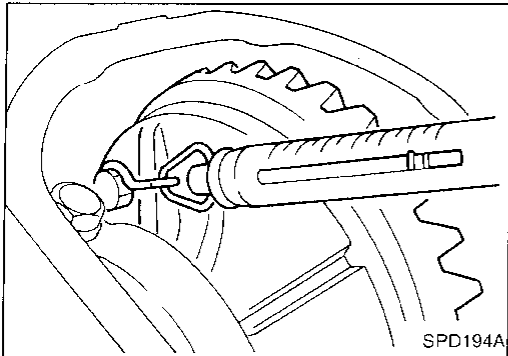

7. Measure the turning torque of the carrier at the ring gear retaining bolts with a spring gauge, J-8129.

Specification:

**34.3 - 39.2 N (3.5 - 4 kg, 7.7 - 8.8 lb)
of pulling force at the ring gear bolt**

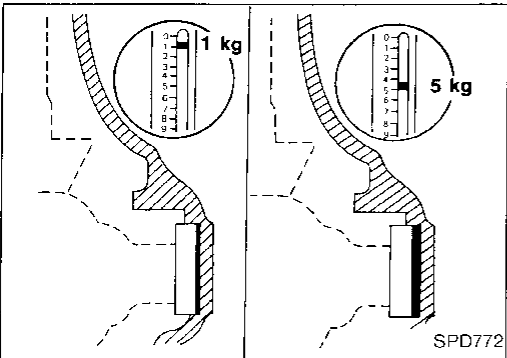

8. If the turning torque is not within the specifications correct the torque as follows:

- If the turning torque is less than the specified range, install washers of greater thickness.
 - If the turning torque is greater than the specification, install thinner washers.
9. Record the total amount of washer thickness required for the correct carrier side bearing preload.

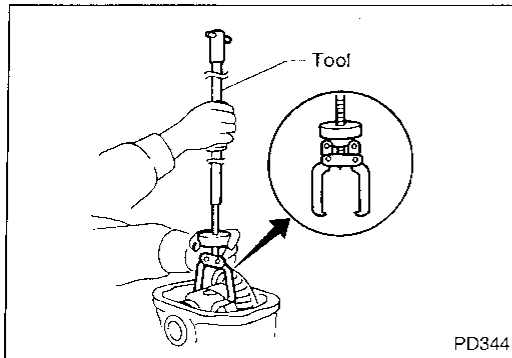

10. Remove the carrier from the final drive housing. Save the selected preload washers for later use during the assembly of the final drive unit.

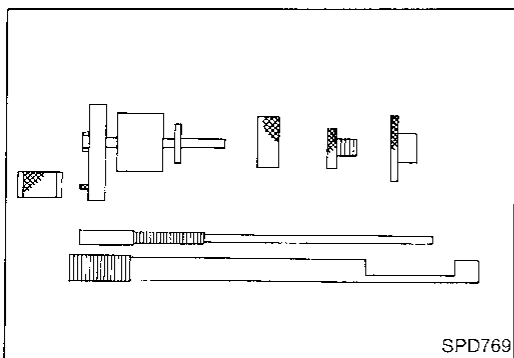

Pinion Gear Height and Pinion Bearing Preload

1. Make sure all parts are clean and that the bearings are well lubricated.
2. Assemble the pinion gear bearings into the pinion preload shim selector Tool, J-34309.

GI

MA

EM

LC

EC

FE

AT

PD

FA

RA

BR

ST

RS

BT

HA

EL

IDX

ADJUSTMENT

Pinion Gear Height and Pinion Bearing Preload (Cont'd)

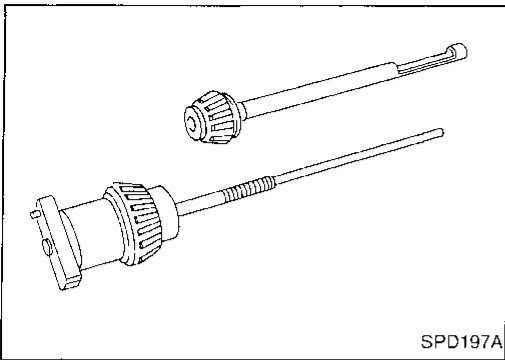

- **Front pinion bearing** — make sure the J-34309-3 front pinion bearing seat is secured tightly against the J-34309-2 gauge anvil. Then turn the front pinion bearing pilot, J-34309-5, to secure the bearing in its proper position.
- **Rear pinion bearing** — the rear pinion bearing pilot, J-34309-8, is used to center the rear pinion bearing only. The rear pinion bearing locking seat, J-34309-4, is used to lock the bearing to the assembly.
- **Installation of J-34309-9 and J-34309-16** — place a suitable 2.5 mm (0.098 in) thick plain washer between J-34309-9 and J-34309-16. Both surfaces of J-34309-9 and J-34309-16 must be parallel with a clearance of 2.5 mm (0.098 in).

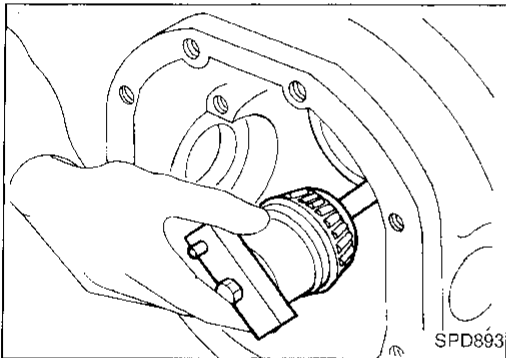

3. Install the pinion rear bearing inner cone into the final drive housing. Then place the pinion preload shim selector Tool, J34309-1, gauge screw assembly.

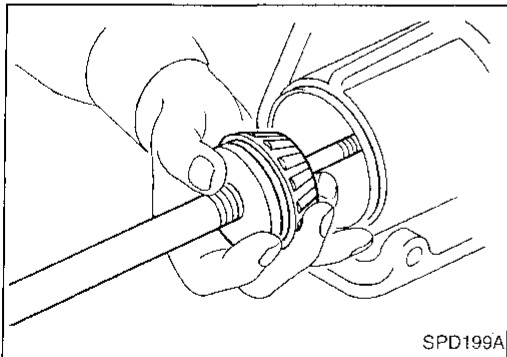

4. Assemble the front pinion bearing inner cone and the J34309-2 gauge anvil. Assemble them together with the J34309-1 gauge screw in the final drive housing. Make sure that the pinion height gauge plate, J34309-16, will turn a full 360 degrees. Tighten the two sections together by hand.

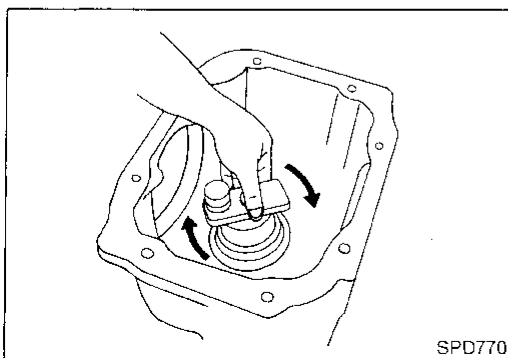

5. Turn the assembly several times to seat the bearings.

ADJUSTMENT

Pinion Gear Height and Pinion Bearing Preload (Cont'd)

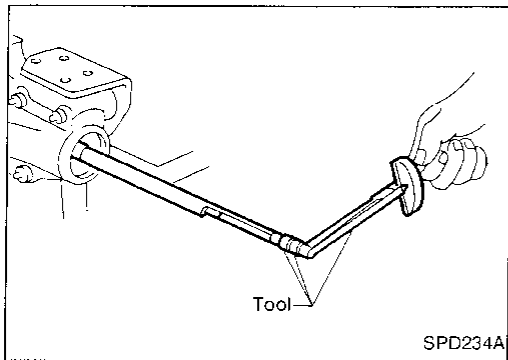

6. Measure the turning torque at the end of the J-34309-2 gauge anvil using torque wrench J-25765A.

Turning torque specification:

1.0 - 1.3 N·m (10 - 13 kg·cm, 8.7 - 11.3 in·lb)

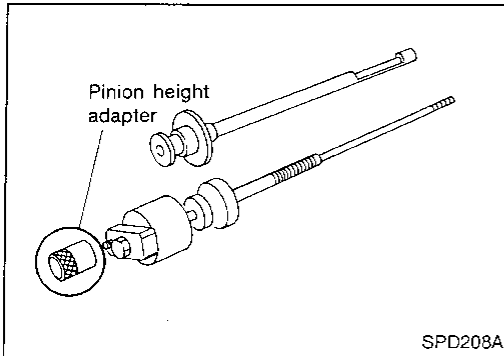

7. Place the J-34309-11 "R200A" pinion height adapter onto the gauge plate and tighten it by hand.

CAUTION:

Make sure all machined surfaces are clean.

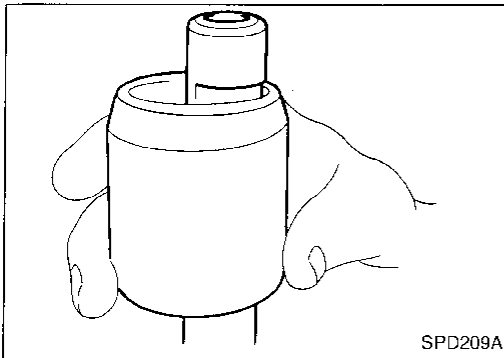

— PINION BEARING PRELOAD WASHER SELECTION —

8. Place the solid pinion bearing spacer, small end first, over the J34309-2 gauge anvil. Seat the small end squarely against the tip of the J34309-1 gauge screw in the tool recessed portion.

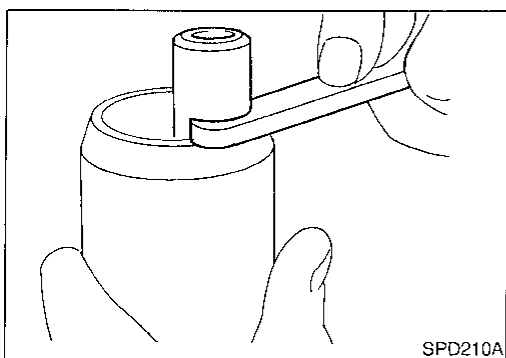
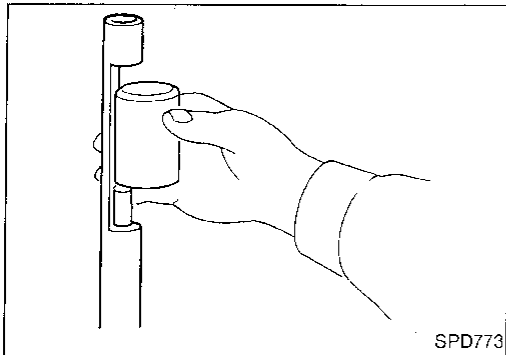

9. Select the correct thickness of pinion bearing preload adjusting washer. Select by using a standard gauge of 3.5 mm (0.138 in) and your J34309-101 feeler gauge. The exact measure you get with your gauges is the thickness of the adjusting washer required. Select the correct washer from the following chart.

Drive pinion bearing preload adjusting washer:

Refer to SDS (PD-30).

GI

MA

EM

LC

EC

FE

AT

PD

FA

RA

BR

ST

BS

BT

HA

EL

IDX

ADJUSTMENT

Pinion Gear Height and Pinion Bearing Preload (Cont'd)

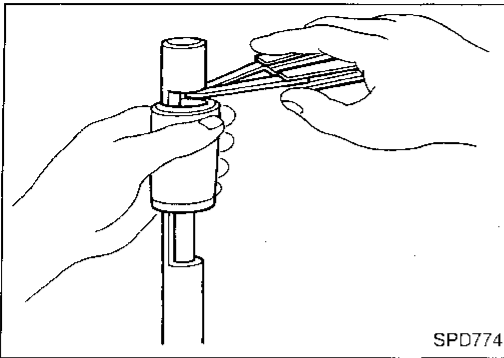

10. Set aside the selected correct pinion bearing preload adjusting washer. Use it when assembling the pinion gear and bearings into the final drive.

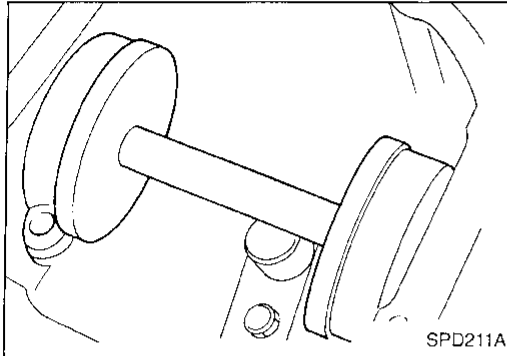

— PINION HEIGHT ADJUSTING WASHER SELECTION —

11. Now, position the side bearing discs, J-25269-4, and arbor firmly into the side bearing bores. Install the side bearing caps and tighten the cap bolts to proper torque.

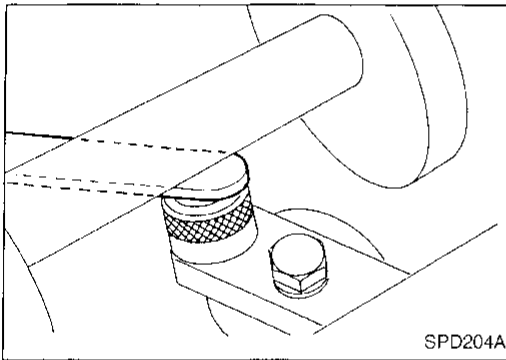

12. Select the correct standard pinion height adjusting washer thickness. Select by using a standard gauge of 3 mm (0.12 in) and your J34309-101 feeler gauge. Measure the distance between the J-34309-11 pinion height adapter including the standard gauge and the arbor.

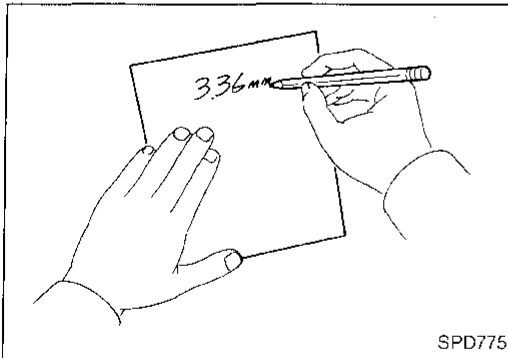

13. Write down your exact measurement (the value of feeler gauge).

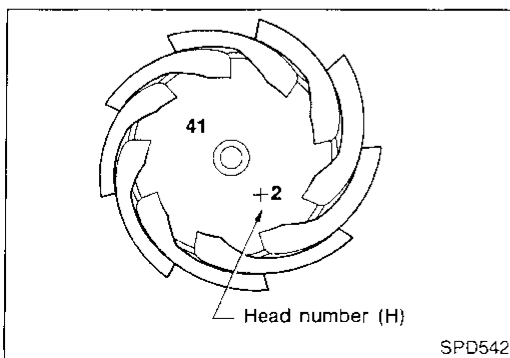

14. Correct the pinion height washer size by referring to the "pinion head number".

There are two numbers painted on the pinion gear. The first one refers to the pinion and ring gear as a matched set. This number should be the same as the number on the ring gear. The second number is the "pinion head height number". It refers to the ideal pinion height from standard for quietest operation. Use the following chart to determine the correct pinion height washer.

ADJUSTMENT

Pinion Gear Height and Pinion Bearing Preload (Cont'd)

Pinion head height number	Add or remove from the standard pinion height washer thickness measurement
- 6	Add 0.06 mm (0.0024 in)
- 5	Add 0.05 mm (0.0020 in)
- 4	Add 0.04 mm (0.0016 in)
- 3	Add 0.03 mm (0.0012 in)
- 2	Add 0.02 mm (0.0008 in)
- 1	Add 0.01 mm (0.0004 in)
0	Use the selected washer thickness
+1	Subtract 0.01 mm (0.0004 in)
+2	Subtract 0.02 mm (0.0008 in)
+3	Subtract 0.03 mm (0.0012 in)
+4	Subtract 0.04 mm (0.0016 in)
+5	Subtract 0.05 mm (0.0020 in)
+6	Subtract 0.06 mm (0.0024 in)

15. Select the correct pinion height washer from the following chart.

**Drive pinion height adjusting washer:
Refer to SDS (PD-30).**

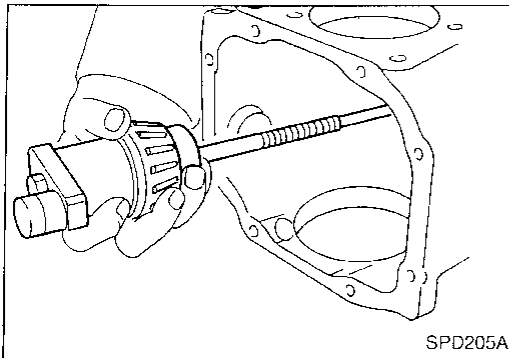

16. Remove the J34309 pinion preload shim selector Tool from the final drive housing. Then disassemble to retrieve the pinion bearings.

CI
 MA
 EM
 EC
 EC
 FE
 AT
 PD
 FA
 RA
 BR
 ST
 RS
 BT
 HA
 EL
 IDX

ADJUSTMENT

Tooth Contact

Checking gear tooth contact pattern is necessary to verify correct relationship between ring gear and drive pinion.

Hypoid gears which are not positioned in proper arrangement may be noisy and/or have a short life. Check gear tooth contact pattern to obtain the best contact for low noise and long life.

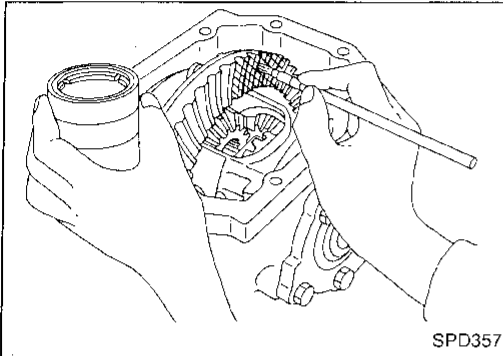

1. Thoroughly clean ring gear and drive pinion teeth.
2. Lightly apply a mixture of powdered ferric oxide and oil or the equivalent. Apply it to 3 or 4 teeth of ring gear drive side.

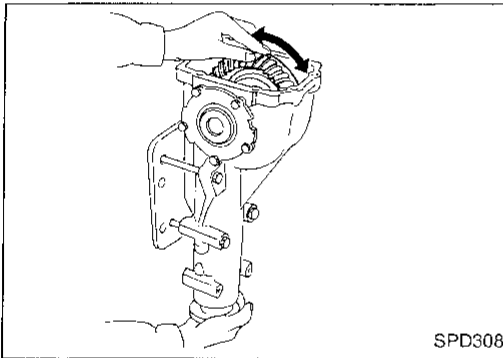

3. Hold companion flange steady by hand and rotate the ring gear in both directions.

Usually the pattern will be correct if shims are correctly calculated and the backlash is correct. However, in rare cases, trial and error processes may be employed to obtain a correct pattern. The tooth pattern is the best indication of how well a differential has been set up.

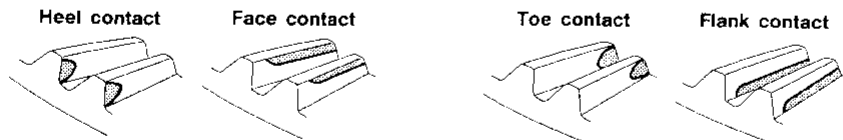

To correct, increase thickness of pinion height adjusting washer in order to bring drive pinion close to ring gear.

To correct, reduce thickness of pinion height adjusting washer in order to make drive pinion go away from ring gear.

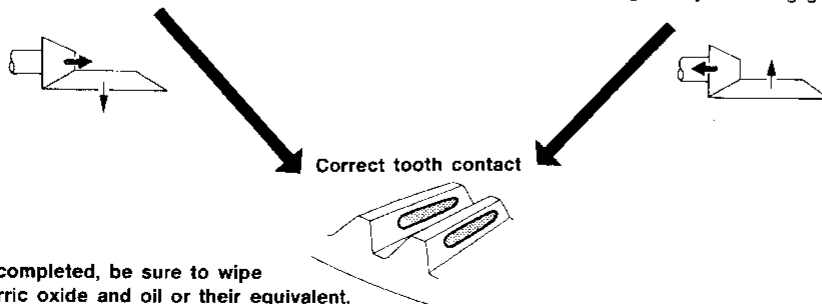

When adjustment is completed, be sure to wipe off completely the ferric oxide and oil or their equivalent.

SPD007-B

ASSEMBLY

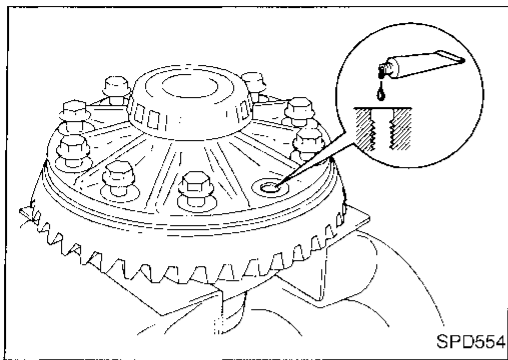

1. Place differential case on ring gear.
 2. Apply locking sealant to ring gear bolts, and install them.
- Tighten bolts in a criss-cross fashion, lightly tapping bolt head with a hammer.**

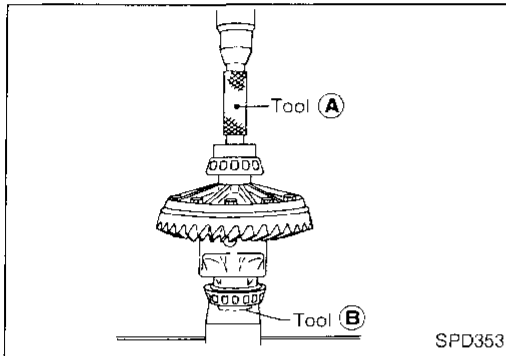

3. Press-fit side bearing inner cones on differential case with Tool.
- Tool number:**
- (A) KV38100300 (J25523)
 - (B) ST33061000 (J8107-2)

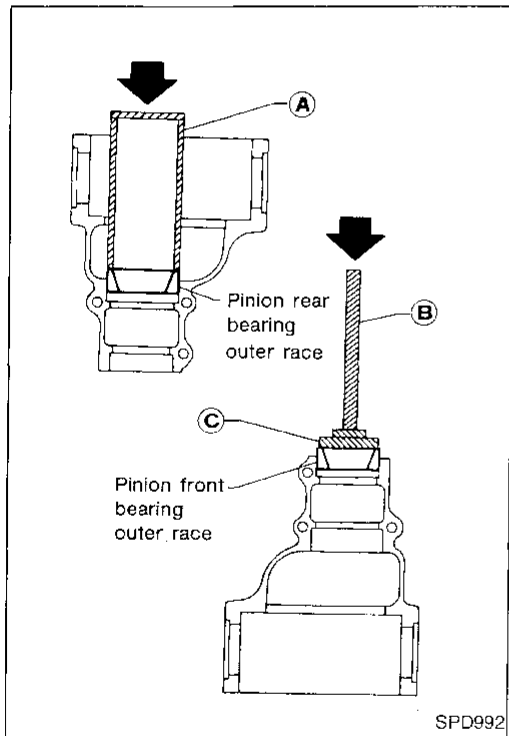

4. Press-fit front and rear bearing outer races with Tools.
- Tool number:**
- (A) Suitable tool
 - (B) ST30611000 (J25742-1)
 - (C) ST30613000 (J25742-3)
5. Select pinion bearing adjusting washer and drive pinion bearing spacer.
- Refer to ADJUSTMENT (PD-19).

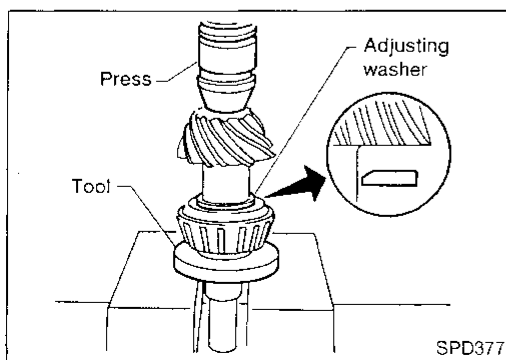

6. Install selected drive pinion height adjusting washer in drive pinion. Using press and Tool, press-fit pinion rear bearing inner cone into it.
- Tool number: ST30901000 (—)**

GI

MA

EM

LC

EC

FE

AT

PD

FA

RA

BR

ST

RS

BT

HA

EL

DX

ASSEMBLY

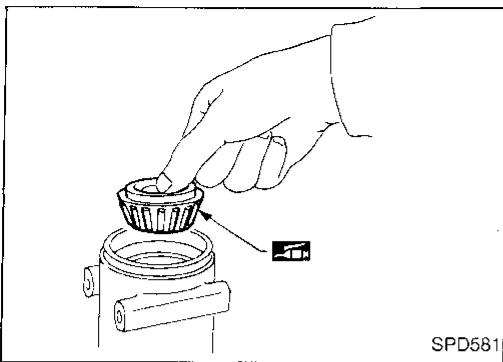

7. Place pinion front bearing inner cone in final drive housing.

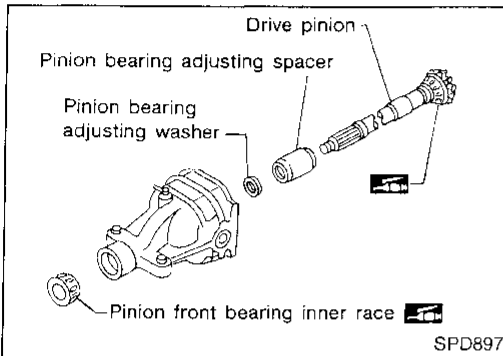

8. Set drive pinion assembly (as shown in figure at left) in differential carrier and install drive pinion, with press and suitable tool.

Stop when drive pinion touches bearing.
Apply multi-purpose grease to pinion rear bearing inner race and pinion front bearing inner race.

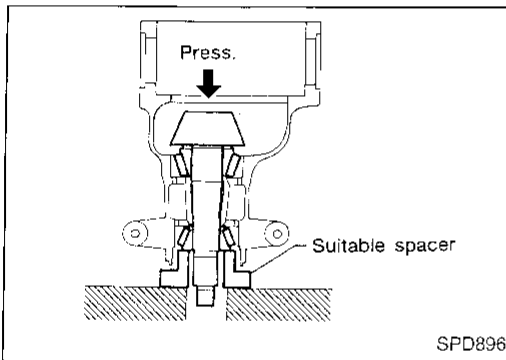

9. Install front oil seal with Tool.

Tool number: KV38100500 (—)

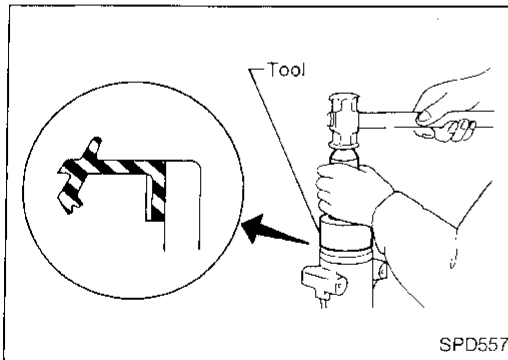

10. Install companion flange, and tighten pinion nut to specified torque with Tool.

Ascertain that threaded portion of drive pinion and pinion nut are free from oil or grease.

Tool number: J34311

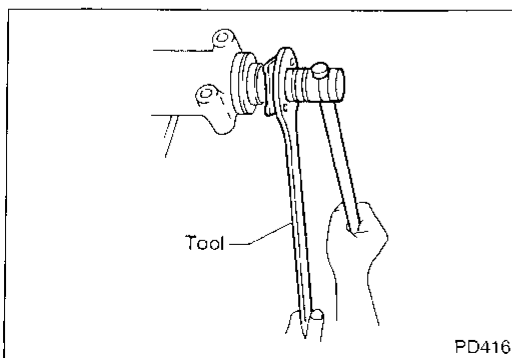

ASSEMBLY

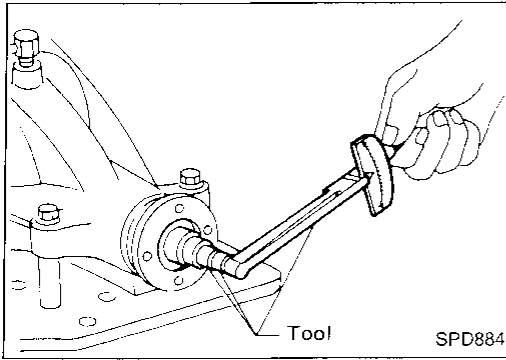

11. Turn drive pinion in both directions several times, and measure pinion bearing preload.

Pinion bearing preload:

1.1 - 1.4 N·m (11 - 14 kg-cm, 9.5 - 12.2 in-lb)

When pinion bearing preload is outside specifications, replacement is required for pinion bearing adjusting washer and spacer. Replace with those of different thickness.

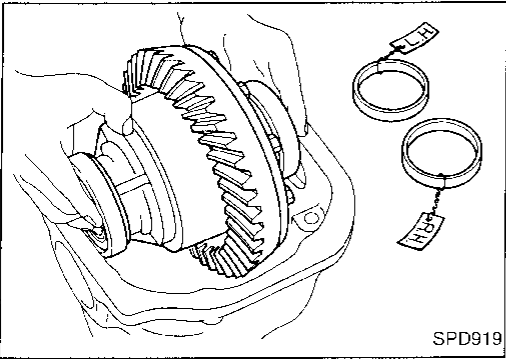

12. Select side bearing adjusting washer. Refer to ADJUSTMENT (PD-18).
13. Install differential case assembly with side bearing outer races into gear carrier.

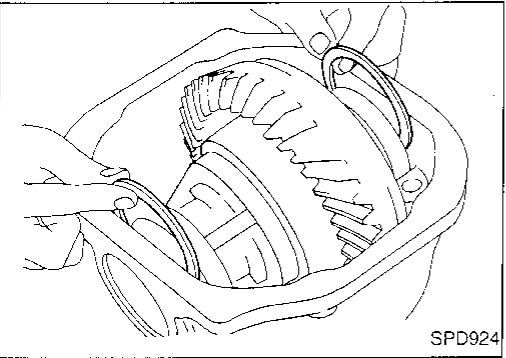

14. Insert left and right side bearing adjusting washers in place between side bearings and carrier.

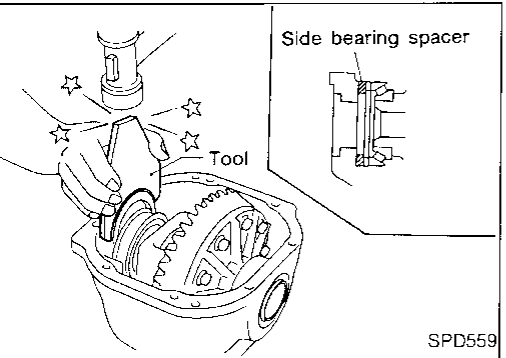

15. Drive in side bearing spacer with Tool.
Tool number: KV38100600 (J25267)
Spacer location:
Right side

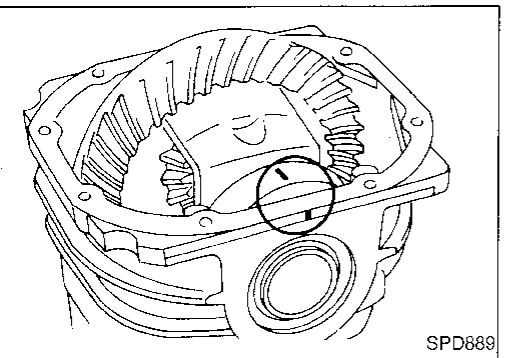

16. Align mark on bearing cap with that on gear carrier and install bearing cap on gear carrier.

GI

MA

EW

LC

EC

FE

AT

PD

EA

RA

BR

ST

RS

BT

HA

EL

IDX

ASSEMBLY

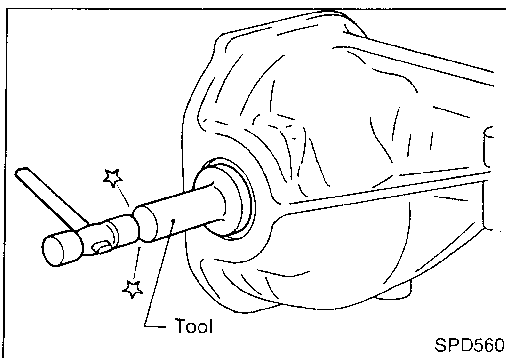

17. Install side oil seal.
Tool number: KV38100200 (J26233)

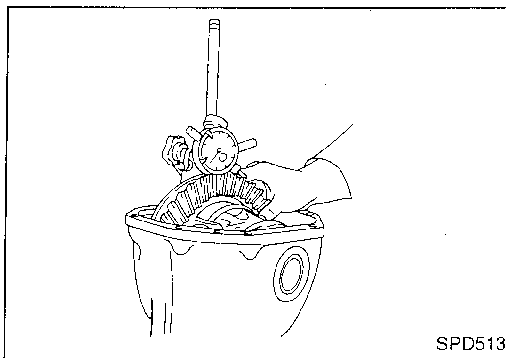

18. Measure ring gear-to-drive pinion backlash with a dial indicator.

Ring gear backlash:
0.10 - 0.15 mm (0.0039 - 0.0059 in)

- If backlash is too small, adjustment of shim thickness is required. Decrease thickness of left shim and increase thickness of right shim by the same amount.

If backlash is too great, reverse the above procedure.

Never change the total amount of shims as it will change the bearing preload.

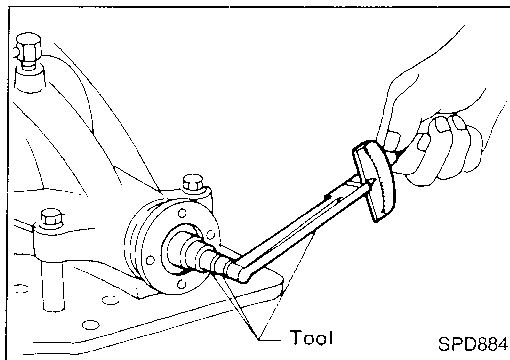

19. Check total preload with Tool.

When checking preload, turn drive pinion in both directions several times to seat bearing rollers correctly.

Total preload:
1.4 - 2.8 N·m (14 - 29 kg-cm, 12 - 25 in-lb)

- If preload is too great, remove the same amount of shim to each side.
- If preload is too small, add the same amount of shim to each side.

Never add or remove a different number of shims for each side. Difference in number of shims will change ring gear to drive pinion backlash.

20. Recheck ring gear to drive pinion backlash. Increase or decrease in thickness of shims will cause change to ring gear to pinion backlash.

- Check whether the backlash varies excessively in different places. Foreign matter may be caught between the ring gear and the differential case causing the trouble.
- The backlash can vary greatly even when the ring gear runout is within a specified range. In that case, replace the hypoid gear set or differential case.

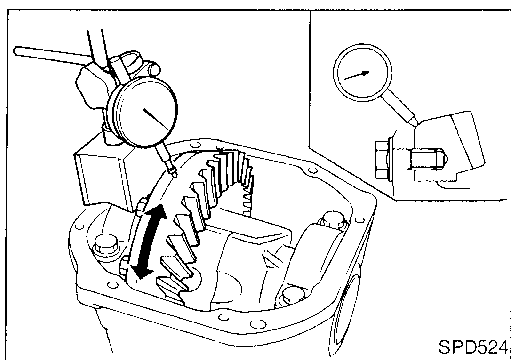

21. Check runout of ring gear with a dial indicator.

Runout limit: 0.05 mm (0.0020 in)

22. Check tooth contact.
Refer to ADJUSTMENT (PD-24).

23. Install rear cover and gasket.

SERVICE DATA AND SPECIFICATIONS (SDS)

Propeller Shaft

GENERAL SPECIFICATIONS

Unit: mm (in)

Propeller shaft model	3S80A-R
Number of joints	3
Coupling method with transmission	Sleeve type
Type of journal bearings	Shell type (Non-disassembly type)
Shaft length (Spider to spider)	
1st	680 (26.77)
2nd	658 (25.91)
Shaft outer diameter	
1st	82.6 (3.252)
2nd	65 (2.56)

SPECIFICATIONS AND ADJUSTMENT

Unit: mm (in)

Propeller shaft runout limit	0.6 (0.024)
Journal axial play	0 (0)

Final Drive

GENERAL SPECIFICATIONS

Final drive model	R200V
Ring gear pitch diameter	mm (in) 205 (8.07)
Gear ratio	3.692
Number of teeth (Ring gear/Drive pinion)	48/13
Oil capacity (approx.)	1.3 (2-3/4, 2-1/4)
ℓ (US pt, Imp pt)	
Number of pinion gears	4
Side gear bearing spacer location	Right

INSPECTION AND ADJUSTMENT

Ring gear runout

Ring gear runout limit	mm (in) 0.05 (0.0020)
------------------------	-----------------------

Side gear adjustment

Clearance between side gear and differential case	mm (in) 0.03 - 0.09 (0.0012 - 0.0035)
---	--

GI

MA

EM

LC

EC

FE

AT

PD

FA

RA

BR

ST

RS

BT

HA

E-

IDX

SERVICE DATA AND SPECIFICATIONS (SDS)

Final Drive (Cont'd)

Available side gear thrust washers

Thickness	mm (in)	Part number
0.80	(0.0315)	38424-40F60
0.83	(0.0327)	38424-40F61
0.86	(0.0339)	38424-40F62
0.89	(0.0350)	38424-40F63
0.92	(0.0362)	38424-40F64
0.95	(0.0374)	38424-40F65
0.98	(0.0386)	38424-40F66
1.01	(0.0398)	38424-40F67
1.04	(0.0409)	38424-40F68
1.07	(0.0421)	38424-40F69
1.10	(0.0433)	38424-40F70
1.13	(0.0445)	38424-40F71
1.16	(0.0457)	38424-40F72
1.19	(0.0469)	38424-40F73
1.22	(0.0480)	38424-40F74
1.25	(0.0492)	38424-40F75
1.28	(0.0504)	38424-40F76
1.31	(0.0516)	38424-40F77
1.34	(0.0528)	38424-40F78
1.37	(0.0539)	38424-40F79
1.40	(0.0551)	38424-40F80
1.43	(0.0563)	38424-40F81
1.46	(0.0575)	38424-40F82
1.49	(0.0587)	38424-40F83

Available drive pinion bearing preload adjusting washers

Thickness	mm (in)	Part number
3.80 - 3.82	(0.1496 - 0.1504)	38125-61001
3.82 - 3.84	(0.1504 - 0.1512)	38126-61001
3.84 - 3.86	(0.1512 - 0.1520)	38127-61001
3.86 - 3.88	(0.1520 - 0.1528)	38128-61001
3.88 - 3.90	(0.1528 - 0.1535)	38129-61001
3.90 - 3.92	(0.1535 - 0.1543)	38130-61001
3.92 - 3.94	(0.1543 - 0.1551)	38131-61001
3.94 - 3.96	(0.1551 - 0.1559)	38132-61001
3.96 - 3.98	(0.1559 - 0.1567)	38133-61001
3.98 - 4.00	(0.1567 - 0.1575)	38134-61001
4.00 - 4.02	(0.1575 - 0.1583)	38135-61001
4.02 - 4.04	(0.1583 - 0.1591)	38136-61001
4.04 - 4.06	(0.1591 - 0.1598)	38137-61001
4.06 - 4.08	(0.1598 - 0.1606)	38138-61001
4.08 - 4.10	(0.1606 - 0.1614)	38139-61001

Available drive pinion bearing preload adjusting spacers

Length	mm (in)	Part number
45.60	(1.7953)	38165-10V05
45.90	(1.8071)	38165-10V06
46.20	(1.8189)	38165-10V07
46.50	(1.8307)	38165-10V00
46.80	(1.8425)	38165-10V01

Drive pinion height adjustment

Available pinion height adjusting washers

Thickness	mm (in)	Part number
3.09	(0.1217)	38154-P6017
3.12	(0.1228)	38154-P6018
3.15	(0.1240)	38154-P6019
3.18	(0.1252)	38154-P6020
3.21	(0.1264)	38154-P6021
3.24	(0.1276)	38154-P6022
3.27	(0.1287)	38154-P6023
3.30	(0.1299)	38154-P6024
3.33	(0.1311)	38154-P6025
3.36	(0.1323)	38154-P6026
3.39	(0.1335)	38154-P6027
3.42	(0.1346)	38154-P6028
3.45	(0.1358)	38154-P6029
3.48	(0.1370)	38154-P6030
3.51	(0.1382)	38154-P6031
3.54	(0.1394)	38154-P6032
3.57	(0.1406)	38154-P6033
3.60	(0.1417)	38154-P6034
3.63	(0.1429)	38154-P6035
3.66	(0.1441)	38154-P6036

Total preload adjustment

Drive pinion to ring gear backlash	mm (in)	0.10 - 0.15 (0.0039 - 0.0059)
Total preload	N-m (kg-cm, in-lb)	1.4 - 2.8 (14 - 29, 12 - 25)

Available side bearing adjusting washers

Thickness	mm (in)	Part number
2.00	(0.0787)	38453-N3100
2.05	(0.0807)	38453-N3101
2.10	(0.0827)	38453-N3102
2.15	(0.0846)	38453-N3103
2.20	(0.0866)	38453-N3104
2.25	(0.0886)	38453-N3105
2.30	(0.0906)	38453-N3106
2.35	(0.0925)	38453-N3107
2.40	(0.0945)	38453-N3108
2.45	(0.0965)	38453-N3109
2.50	(0.0984)	38453-N3110
2.55	(0.1004)	38453-N3111
2.60	(0.1024)	38453-N3112
2.65	(0.1043)	38453-N3113

Drive pinion preload adjustment

Drive pinion bearing adjusting method	Pinion bearing adjusting washer and spacer
Drive pinion preload with front oil seal	1.1 - 1.4 (11 - 14, 9.5 - 12.2) N-m (kg-cm, in-lb)