

REAR AXLE & REAR SUSPENSION

SECTION **RA**

GI

MA

EM

LC

EC

FE

AT

PD

FA

RA

BR

ST

RS

BT

HA

EL

IDX

CONTENTS

PRECAUTIONS AND PREPARATION2	REAR AXLE8	
Precautions2	Wheel Hub and Axle Housing8	
Special Service Tools2	Drive Shaft.....14	
Commercial Service Tools3	REAR SUSPENSION18	
REAR AXLE AND REAR SUSPENSION4	Removal and Installation19	
ON-VEHICLE SERVICE5	Coil Spring and Shock Absorber20	
Rear Axle and Rear Suspension Parts5	Multi-link and Lower Ball Joint.....21	
Rear Wheel Bearing6	Stabilizer Bar24	
Rear Wheel Alignment.....6	SERVICE DATA AND SPECIFICATIONS (SDS)25	
Drive Shaft7	General Specifications.....25	
	Inspection and Adjustment25	

PRECAUTIONS AND PREPARATION

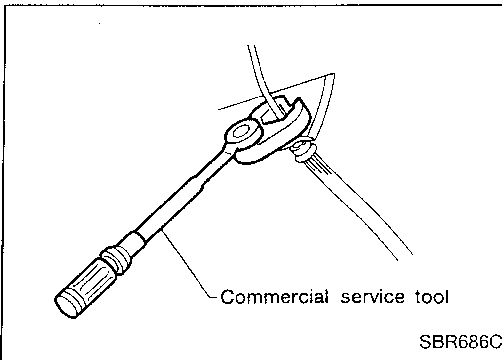

Precautions

- When installing rubber parts, final tightening must be carried out under unladen condition* with tires on ground.
- * Fuel, radiator coolant and engine oil full. Spare tire, jack, hand tools and mats in designated positions.
- Use flare nut wrench when removing or installing brake lines.
- After installing removed suspension parts, check wheel alignment and adjust if necessary.
- Always torque brake lines when installing.
- Do not jack up at the lower arm.

Special Service Tools

The actual shapes of Kent-Moore tools may differ from those of special service tools illustrated here.

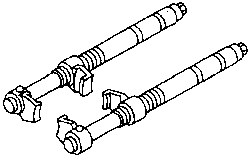
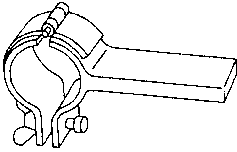
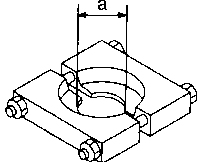
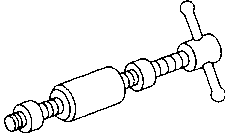
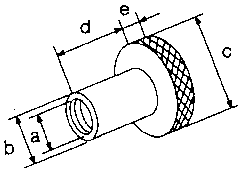
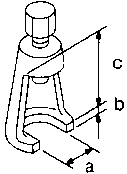
Tool number (Kent-Moore No.) Tool name	Description
HT71780000 (—) Spring compressor	 <p style="text-align: center;">NT144</p> <p style="text-align: right;">Removing and installing coil spring</p>
ST35652000 (—) Shock absorber attachment	 <p style="text-align: center;">NT145</p> <p style="text-align: right;">Fixing strut assembly</p>
ST30031000 (J22912-01) Bearing puller	 <p style="text-align: center;">NT412</p> <p style="text-align: right;">Removing inner race of wheel bearing</p> <p style="text-align: right;">a: 50 mm (1.97 in) dia.</p>
ST38280000 (—) Arm bushing remover	 <p style="text-align: center;">NT157</p> <p style="text-align: right;">Removing and installing rear axle housing bushing</p>
IM23600800 (—) Attachment	 <p style="text-align: center;">NT148</p> <p style="text-align: right;">Measure rear wheel alignment</p> <p style="text-align: right;">a: Screw M24 x 1.5 b: 35 mm (1.38 in) dia. c: 65 mm (2.56 in) dia. d: 56 mm (2.20 in) e: 12 mm (0.47 in)</p>
ST29020001 (24319-01) Pitman arm puller	 <p style="text-align: center;">NT551</p> <p style="text-align: right;">Removing lower ball joint</p> <p style="text-align: right;">a: 34 mm (1.34 in) b: 6.5 mm (0.256 in) c: 61.5 mm (2.421 in)</p>

PRECAUTIONS AND PREPARATION

Commercial Service Tools

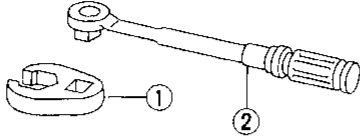
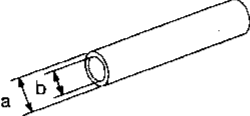
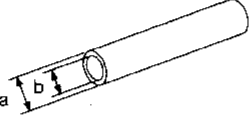
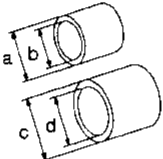
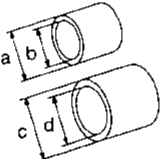
Tool name	Description	GI
① Flare nut crowfoot ② Torque wrench	Removing and installing each brake piping  NT223	MA
Rear wheel bearing drift	Installing wheel bearing  NT065 a: 76 mm (2.99 in) dia. b: 68.5 mm (2.697 in) dia.	EM
Rear drive shaft plug seal drift	Installing rear drive shaft plug seal  NT065 a: 78 mm (3.07 in) dia. b: 72 mm (2.83 in) dia.	EC
Rear axle housing ball joint drift	Removing ball joint  NT164 a: 28 mm (1.10 in) dia. b: 20 mm (0.79 in) dia. c: 43 mm (1.69 in) dia. d: 40 mm (1.57 in) dia.	AT
Rear axle housing ball joint drift	Installing ball joint  NT164 a: 43 mm (1.69 in) dia. b: 33 mm (1.30 in) dia. c: 40 mm (1.57 in) dia. d: 30 mm (1.18 in) dia.	FA

RA

BR

ST

RS

BT

HA

EL

IDX

REAR AXLE AND REAR SUSPENSION

SEC. 380•396•430•431

When installing rubber parts, final tightening must be carried out under unladen condition* with tires on ground.

* Fuel, radiator coolant and engine oil full.

Spare tire, jack, hand tools and mats in designated positions.

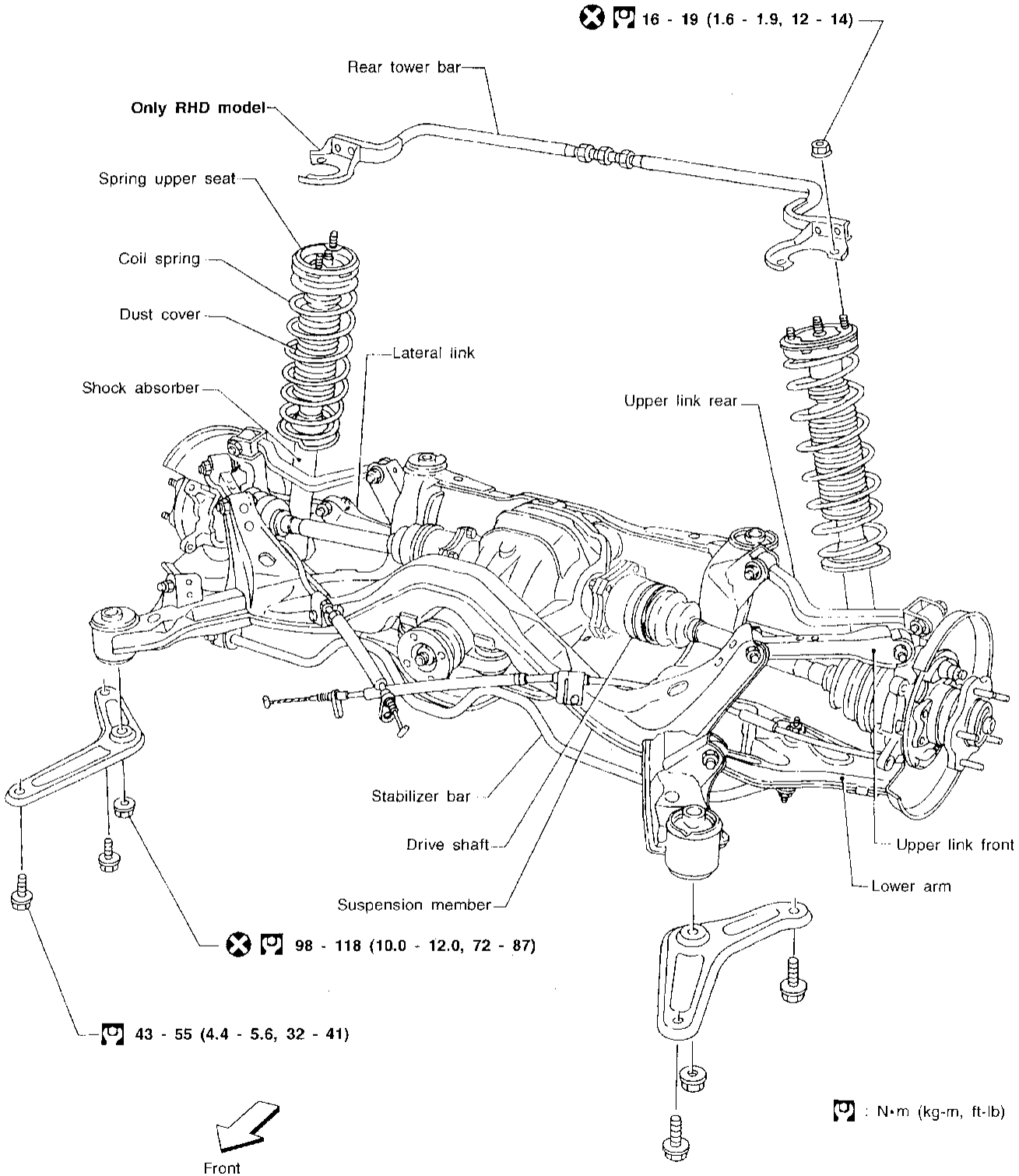

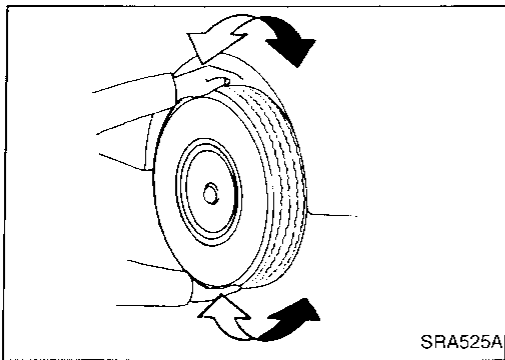

Rear Axle and Rear Suspension Parts

Check axle and suspension parts for excessive play, wear or damage.

- Shake each rear wheel to check for excessive play.

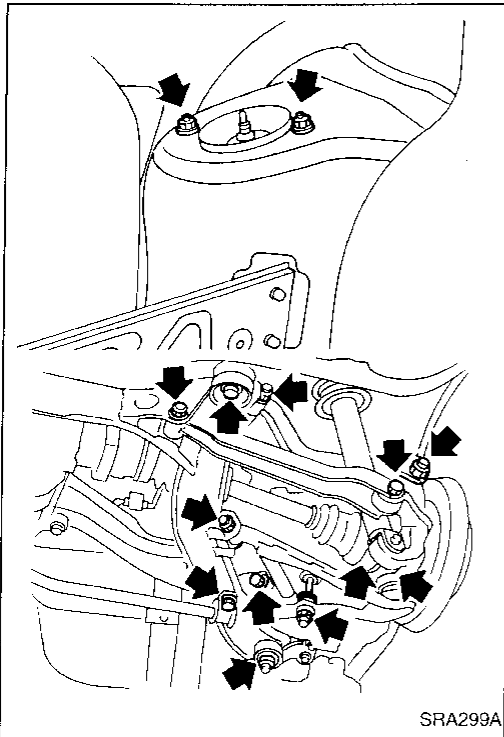

- Retighten all nuts and bolts to the specified torque.
Tightening torque:
Refer to drawing in REAR SUSPENSION (RA-18).
- Make sure that cotter pin is inserted.

GI

MA

EM

LC

EC

FE

AT

PD

FA

RA

BR

ST

RS

BT

HA

EL

DX

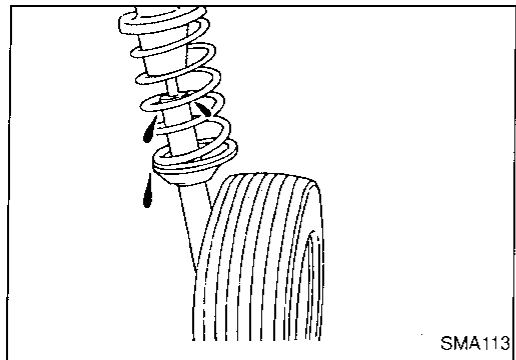

- Check shock absorber for oil leakage or other damage.
- Check wheelarch height. Refer to Front Axle and Front Suspension Parts of ON-VEHICLE SERVICE in FA section.

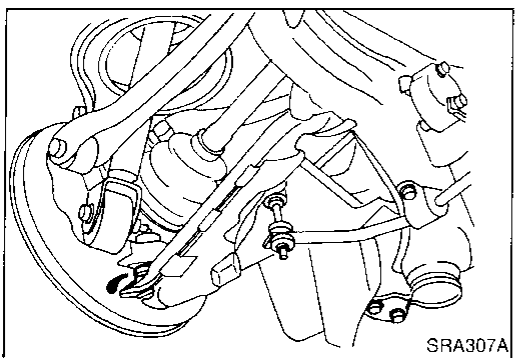

- Check suspension ball joint for grease leakage and ball joint dust cover for cracks or other damage.

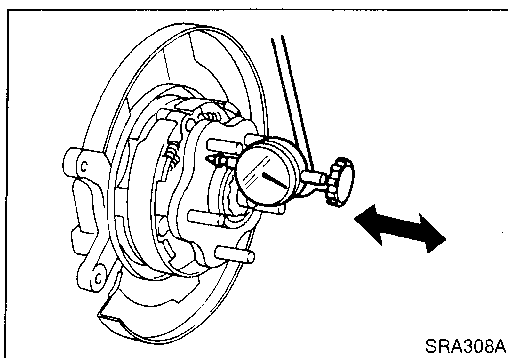

Rear Wheel Bearing

- Check wheel bearings for smooth operation.
- Check axial end play.

Axial end play:

0.05 mm (0.0020 in) or less

If axial end play is not within specification or wheel bearing does not turn smoothly, replace wheel bearing assembly. Refer to Wheel Hub and Axle Housing in REAR AXLE (RA-9).

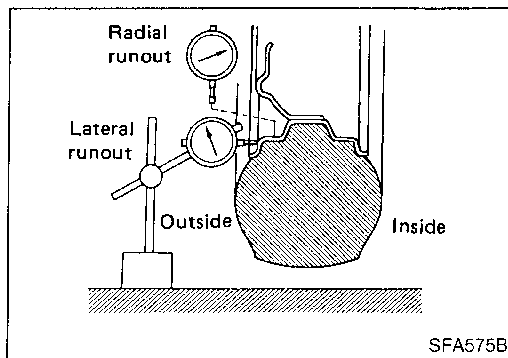

Rear Wheel Alignment

Before checking rear wheel alignment, be sure to make a preliminary inspection.

PRELIMINARY INSPECTION

Make the following checks. Adjust, repair or replace if necessary.

- Check tires for wear and for proper inflation.
- Check rear wheel bearings for excessive play.
- Check wheel runout.

Refer to SDS in FA section.

- Check that rear shock absorber works properly.
- Check rear axle and rear suspension parts for excessive play.
- Check vehicle posture (Unladen).
("Unladen": Fuel, radiator coolant and engine oil full. Spare tire, jack, hand tools and mats in designated positions.)

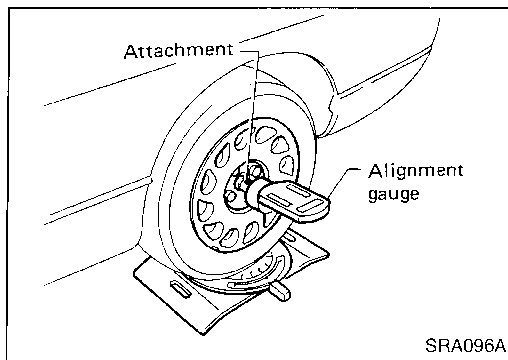

CAMBER

- Measure camber of both right and left wheels with a suitable alignment gauge and adjust in accordance with the following procedures.

Camber:

Refer to SDS (RA-25).

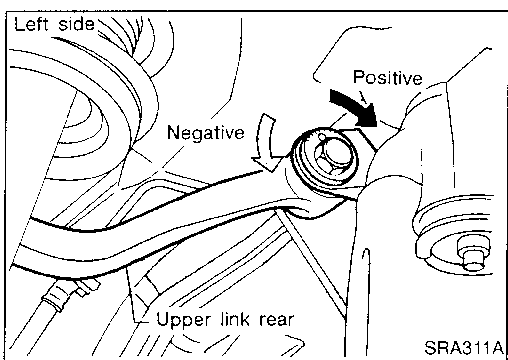

If camber is not within specification, adjust by turning the adjusting bolt.

- Turn the adjusting bolt to adjust.

Camber changes about 5' with each graduation of the adjusting bolt.

- Tighten to the specified torque.

**⚙️: 69 - 88 N·m
(7.0 - 9.0 kg-m, 51 - 65 ft-lb)**

ON-VEHICLE SERVICE

Rear Wheel Alignment (Cont'd)

TOE-IN

Measure toe-in using following procedure. If out of specification, inspect and replace any damaged or worn rear suspension parts.

WARNING:

- Always perform following procedure on a flat surface.
- Make sure that no person is in front of the vehicle before pushing it.

1. Bounce rear of vehicle up and down to stabilize the posture.
2. Push the vehicle straight ahead about 5 m (16 ft).
3. Put a mark on base line of the tread (rear side) of both tires at the same height of hub center. This mark is a measuring point.
4. Measure distance "A" (rear side).
5. Push the vehicle slowly ahead to rotate the wheels 180 degrees (1/2 turn).

If the wheels have rotated more than 180 degrees (1/2 turn), try the above procedure again from the beginning. Never push vehicle backward.

6. Measure distance "B" (front side).

Total toe-in:

Refer to SDS (RA-25).

7. Adjust toe-in by turning adjusting bolts.

Toe changes about 1.5 mm (0.059 in) [One side] with each graduation of the adjusting bolt.

8. Tighten to the specified torque.

: 69 - 88 N·m

(7.0 - 9.0 kg-m, 51 - 65 ft-lb)

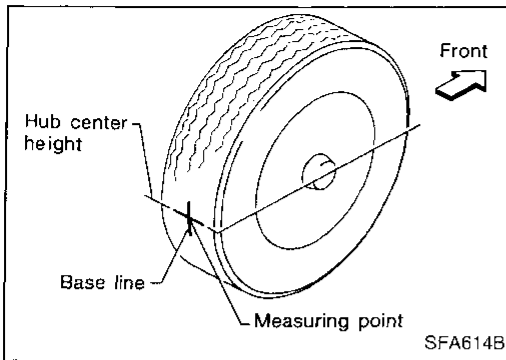

SFA614B

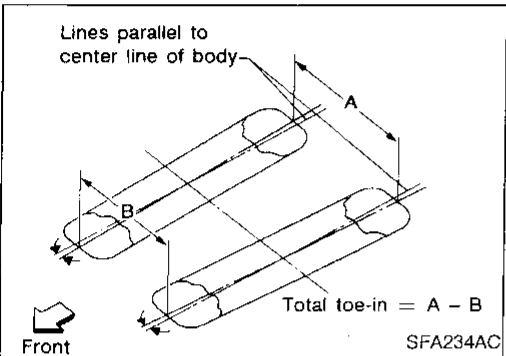

SFA234AC

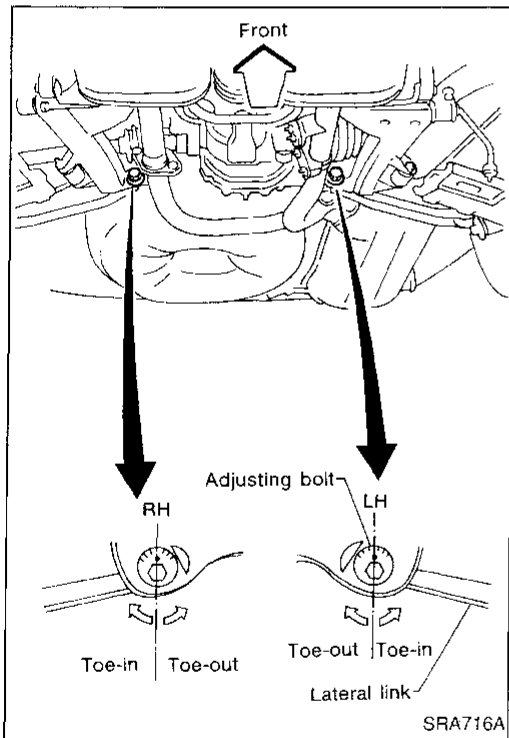

SRA716A

Drive Shaft

Check boot and drive shaft for cracks, wear, damage or grease leakage.

GI
MA
EM
LC
EC
FE
AT
PD
FA
RA
BR
ST
RS
BT
HA
EL
IDX

REAR AXLE

Wheel Hub and Axle Housing

SEC. 396•430

When installing rubber parts, final tightening must be carried out under unladen condition* with tires on ground.

* Fuel, radiator coolant and engine oil full.

Spare tire, jack, hand tools and mats in designated positions.

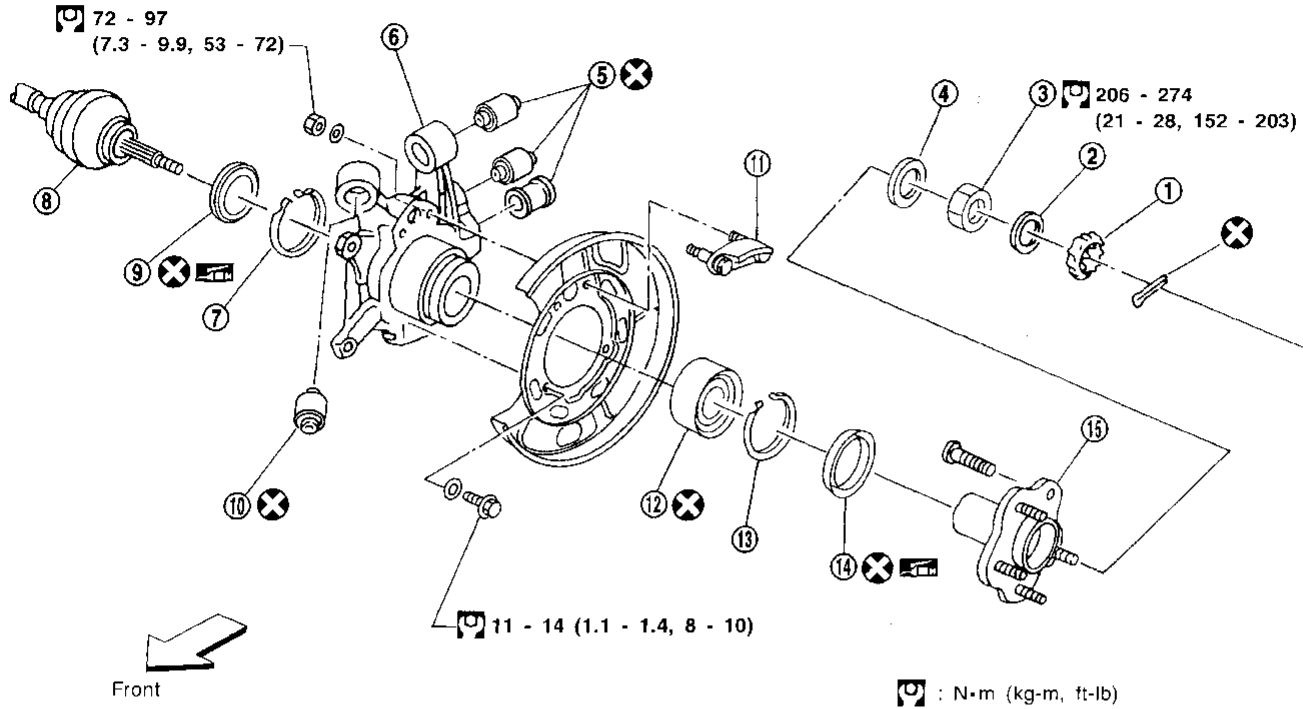

SRA782A

- | | | |
|--------------------------|----------------|-----------------|
| ① Adjusting cap | ⑥ Axle housing | ⑪ Anchor block |
| ② Insulator | ⑦ Snap ring | ⑫ Wheel bearing |
| ③ Wheel bearing lock nut | ⑧ Drive shaft | ⑬ Snap ring |
| ④ Washer | ⑨ Grease seal | ⑭ Grease seal |
| ⑤ Bushing | ⑩ Bushing | ⑮ Wheel hub |

REAR AXLE

Wheel Hub and Axle Housing (Cont'd)

REMOVAL

- Remove wheel bearing lock nut.
- Separate drive shaft from axle housing by lightly tapping it. If it is hard to remove use puller.

When removing drive shaft, cover boots with shop towel to prevent them from being damaged.

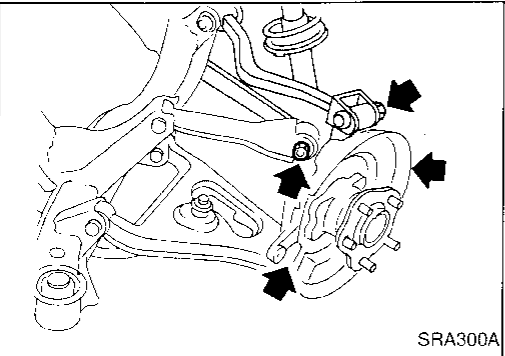
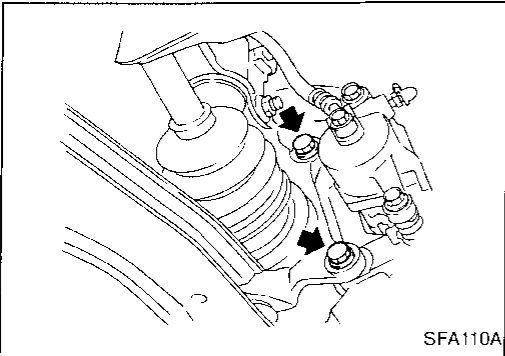
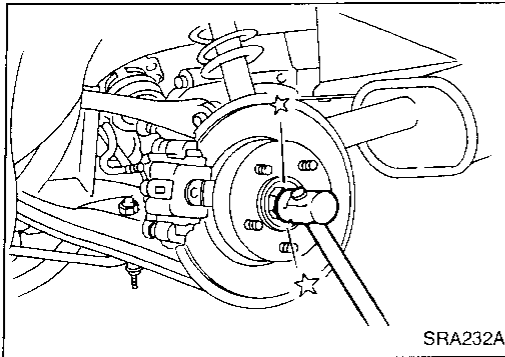

- Remove brake caliper assembly and rotor. Brake line need not be disconnected from brake caliper. Be careful not to depress brake pedal, or piston will pop out. Do not pull or twist brake hose.

- Remove axle housing.

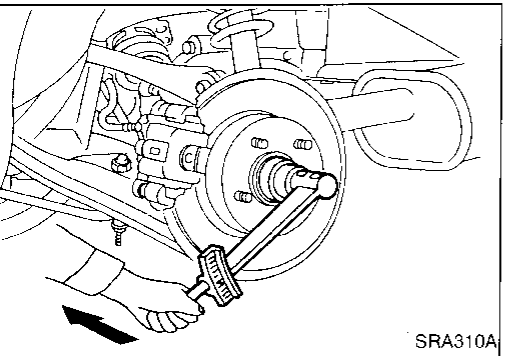

INSTALLATION

- Install axle housing with wheel hub.
- Tighten wheel bearing lock nut. Before tightening, apply oil to threaded portion of rear spindle and both sides of plain washer.

: 206 - 274 N·m
(21 - 28 kg-m, 152 - 203 ft-lb)

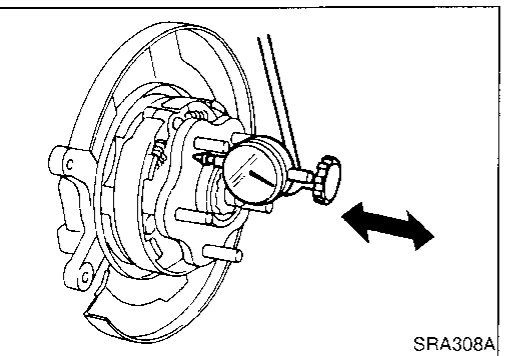

- Check wheel bearing axial end play. Axial end play: 0.05 mm (0.0020 in) or less
- Make sure that wheel bearings operate smoothly.
- Check toe-in — Refer to ON-VEHICLE SERVICE (RA-7).

REAR AXLE

Wheel Hub and Axle Housing (Cont'd)

DISASSEMBLY

CAUTION:

Wheel bearing does not require maintenance. If any of the following symptoms are noted, replace wheel bearing assembly.

- Growling noise is emitted from wheel bearing during operation.
- Wheel hub bearing drags or turns roughly. This occurs when turning hub by hand after bearing lock nut is tightened to specified torque.
- After wheel bearing is removed from hub.

Wheel bearing

- Remove wheel hub from axle housing using a suitable tool.

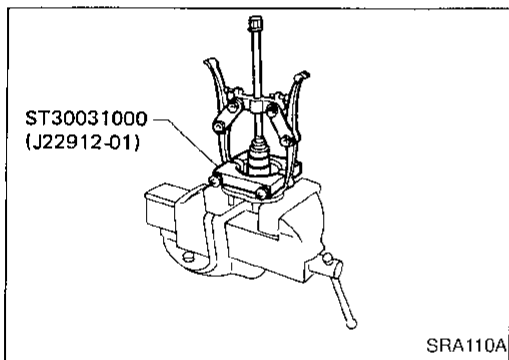
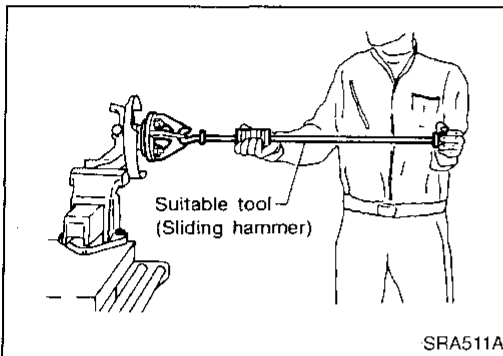

- Remove inner race from hub using a bearing replacer/puller.

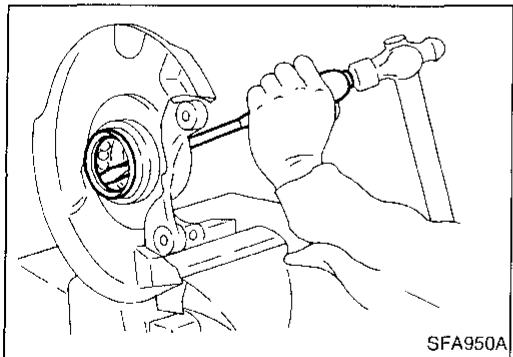

- Remove grease seals from axle housing.

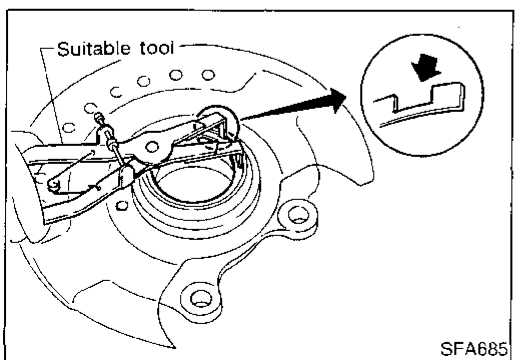

- Remove snap rings.

REAR AXLE

Wheel Hub and Axle Housing (Cont'd)

- Press out bearing outer race.

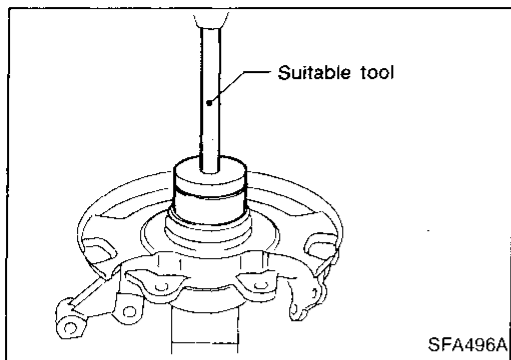

CAUTION:

Do not reuse old inner race although it is of the same brand as the bearing assembly.

GA
MA
EM
LC
EC
FE
AT

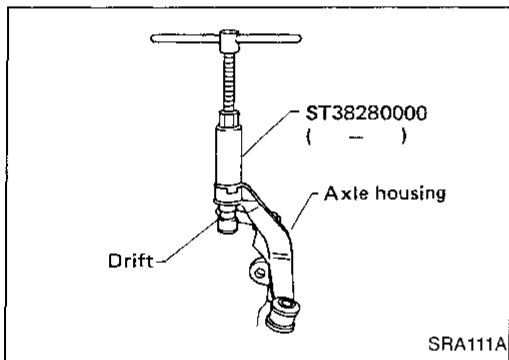

Axle housing

- Attach a drift on outer shell of bushing as shown in figure at left, remove bushing using arm bushing remover.

When placing axle housing in a vise, use wooden blocks or copper plates as pads.

PD
FA

RA
BR

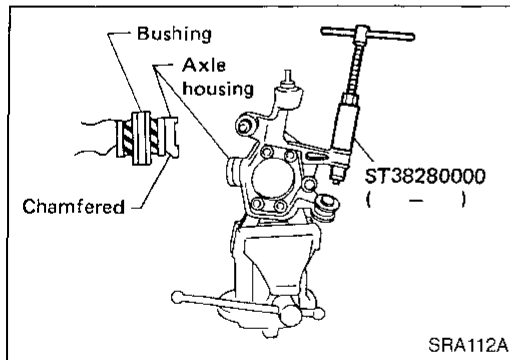

- Ensure axle housing bore is free from scratches or deformities before pressing bushing into it.
- Attach bushing to chamfered bore end of axle housing and press it until it is flush with end face of axle housing.

ST
RS
BT

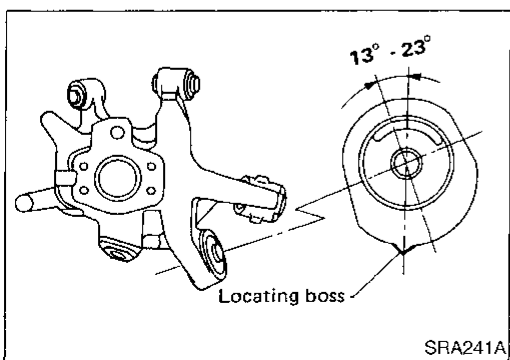

- When installing shock absorber bushing, make sure that it is positioned as shown.

EL
DX

REAR AXLE

Wheel Hub and Axle Housing (Cont'd)

INSPECTION

Wheel hub and axle housing

- Check wheel hub and axle housing for cracks by using a magnetic exploration or dyeing test.
 - Check wheel bearing for damage, seizure, rust or rough operation.
 - Check rubber bushing for wear or other damage.
 - Check snap ring for wear or cracks.
- Replace if necessary.

ASSEMBLY

1. Install snap ring into groove of axle housing.

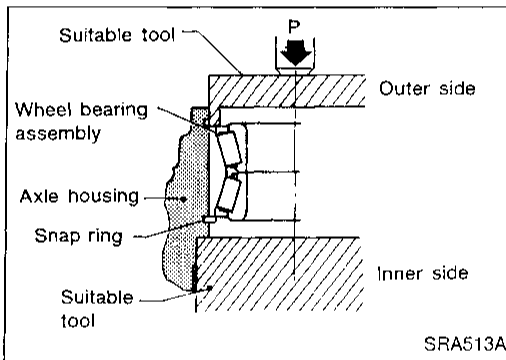
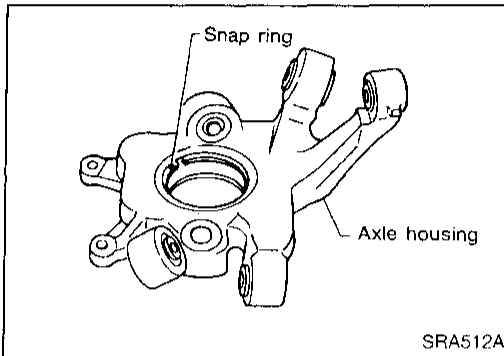

2. Press new wheel bearing assembly into axle housing. Press only on outer race of wheel bearing assembly.

Maximum load P:

29 kN (3 ton, 3.3 US ton, 3.0 Imp ton)

CAUTION:

- Do not press inner race of wheel bearing assembly.
- Do not apply oil or grease to mating surfaces of wheel bearing outer race and axle housing.
- Before pressing, check for correct bearing grease seal orientation, as inner and outer seals are different.

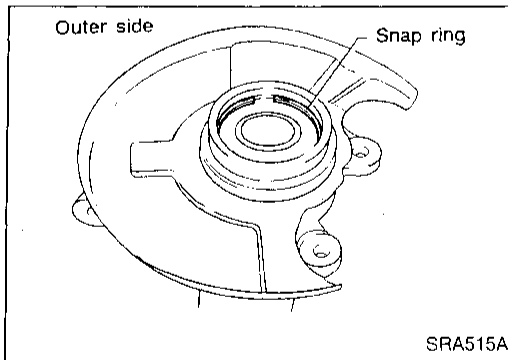

- Install snap ring.

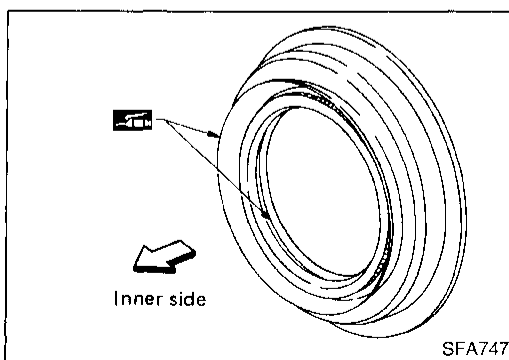

- Pack grease seal lip with multi-purpose grease.

REAR AXLE

Wheel Hub and Axle Housing (Cont'd)

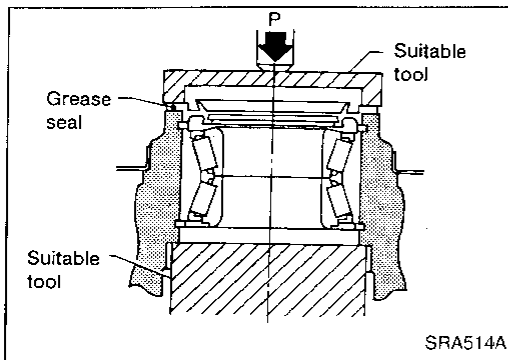

- Install outer grease seal.

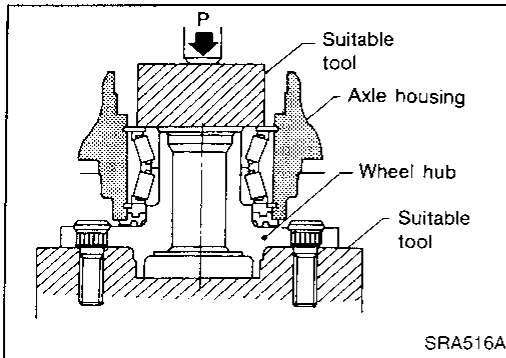

- Press wheel hub into axle housing with suitable tool.
Maximum load P:
29 kN (3 ton, 3.3 US ton, 3.0 Imp ton)
Be careful not to damage grease seal.

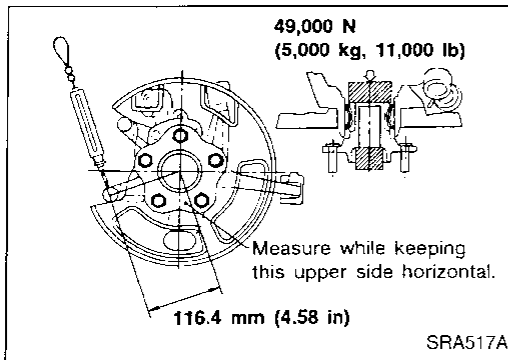

With wheel hub pressed into axle housing, apply 49,000 N (5,000 kg, 11,000 lb) to wheel hub and rotate both clockwise and counter-clockwise 10 times to minimize resistance. Attach spring scale in the position shown at left and pull at a rate of 10 rpm to measure rotating torque.

Load:

49,000 N (5,000 kg, 11,000 lb)

Rotating torque:

0.2 - 2.4 N-m (2.3 - 24.3 kg-cm, 2.0 - 21.1 in-lb)

Spring scale reading:

2.0 - 20.6 N (0.2 - 2.1 kg, 0.4 - 4.6 lb)

If measured value is outside specifications, replace wheel bearing. Also make sure axial play does not exist in wheel hub when a 49,000 N (5,000 kg, 11,000 lb) load is applied.

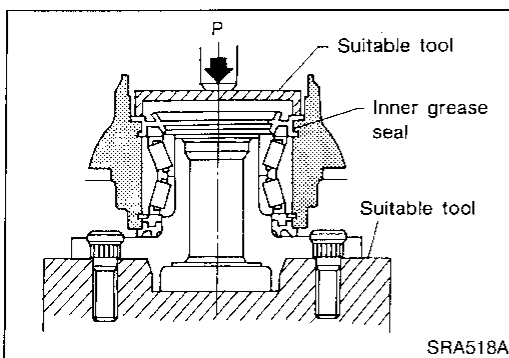

- Install inner grease seal.

REAR AXLE

Drive Shaft

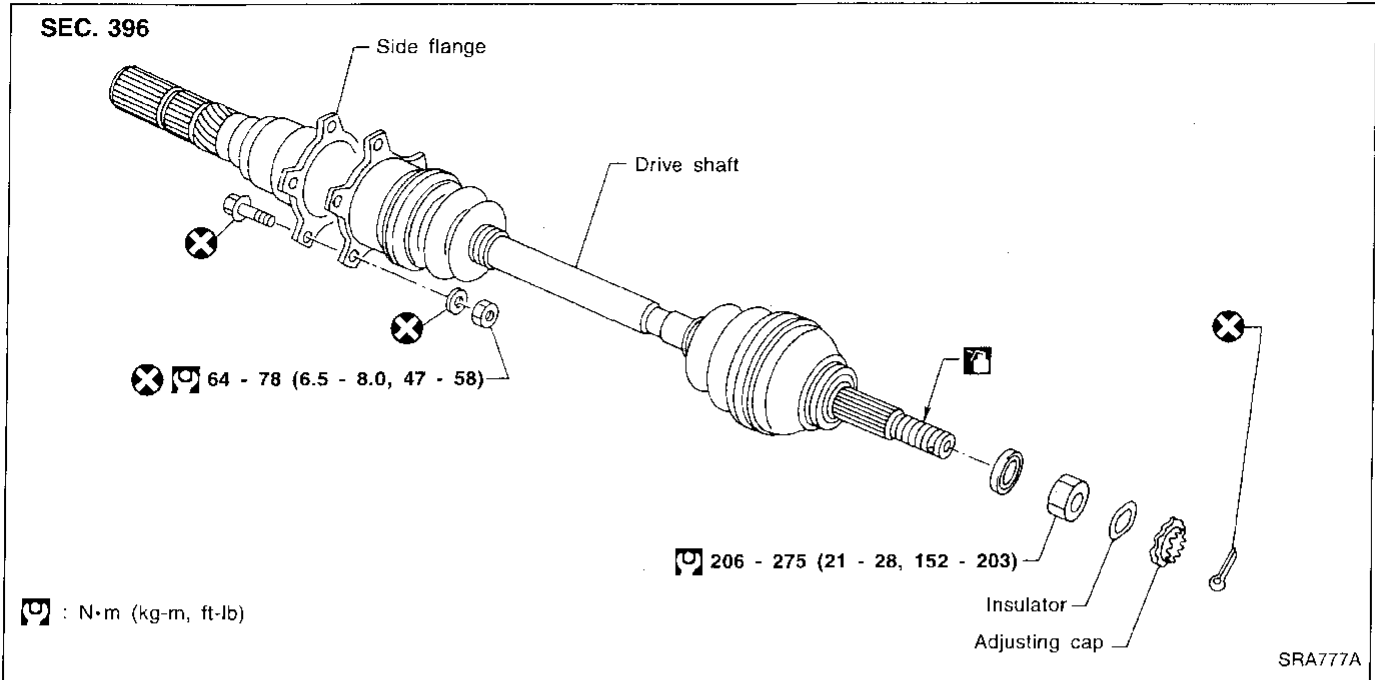

REMOVAL

- Before removing the drive shaft assembly, disconnect the ABS wheel sensor to prevent the damage of the sensor.
- Cover boots with shop towel so as not to damage them when removing drive shaft.

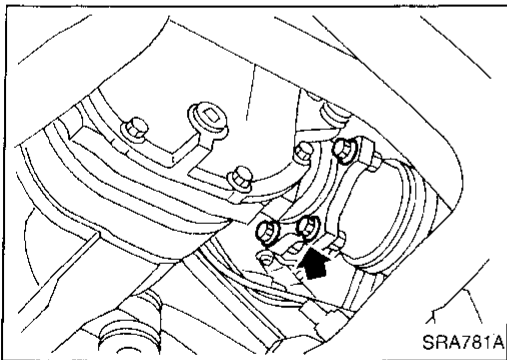

Final drive side

Remove side flange mounting bolt and separate shaft.

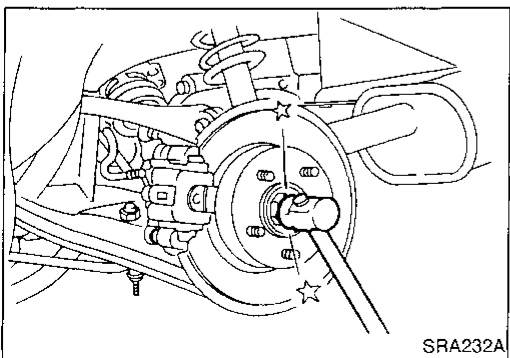

Wheel side

Remove drive shaft by lightly tapping it with a copper hammer. If it is hard to remove, use a puller.

To avoid damaging threads of drive shaft, install a nut while removing drive shaft.

INSTALLATION

1. Insert drive shaft from wheel hub and temporarily tighten wheel bearing lock nut.
2. Tighten side flange mounting bolts to specified torque.
3. Tighten wheel bearing lock nut to specified torque.

REAR AXLE

Drive Shaft (Cont'd)

COMPONENTS

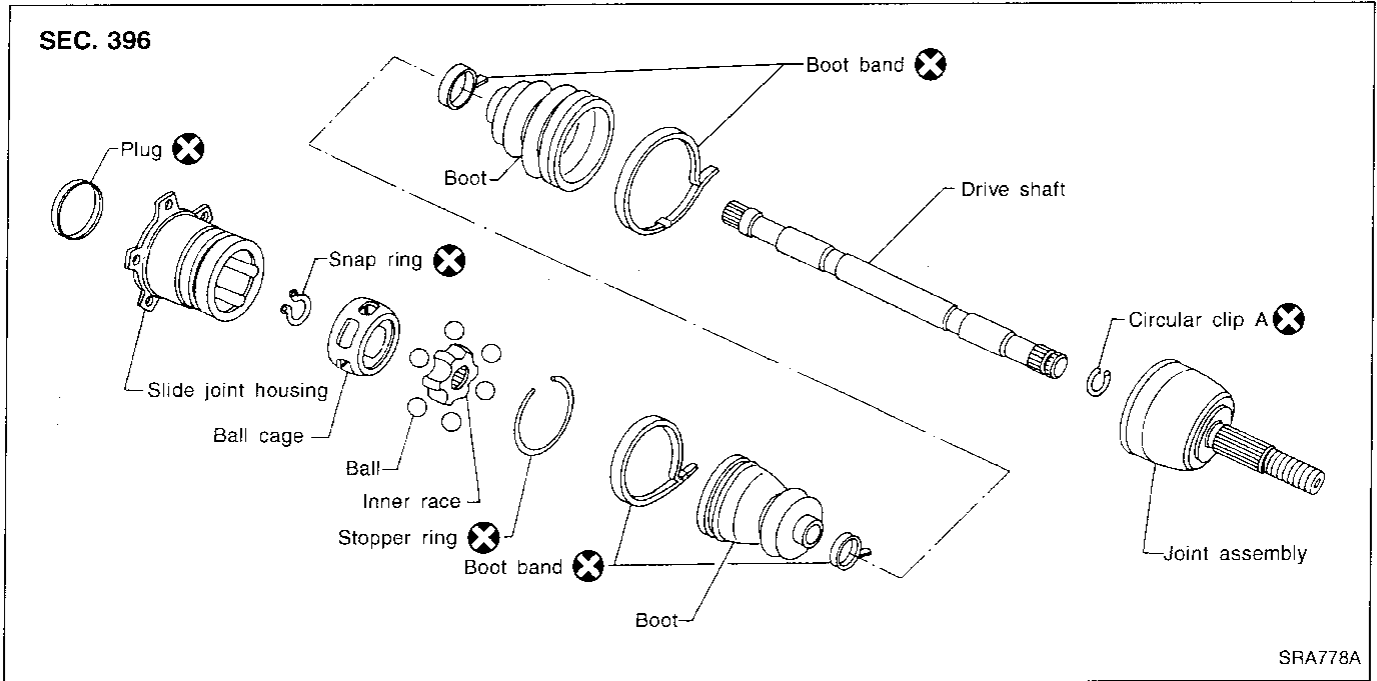

GI
MA
EM
LC
EC
FE
AT

PD
FA
RA

BR
ST
PS
BT
HA

E
IDX

DISASSEMBLY

Final drive side

1. Remove boot bands.
2. Put matching marks on slide joint housing and inner race, before separating joint assembly.
3. Remove stopper ring with a screwdriver, and pull out slide joint housing.

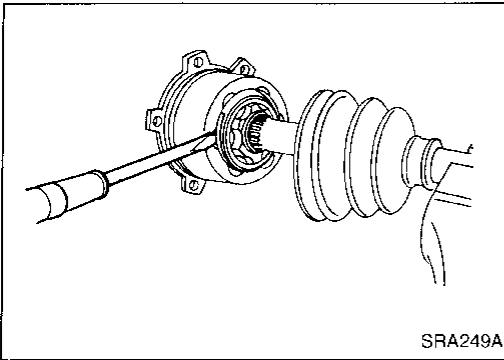

4. Put matching marks on inner race and drive shaft.
5. Remove snap ring, then remove ball cage, inner race and balls as a unit.
6. Draw out boot.

Cover drive shaft serration with tape to prevent damage to the boot.

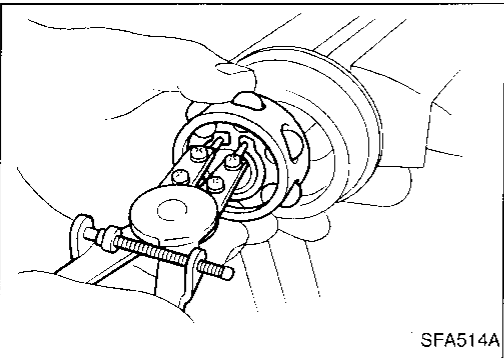

Wheel side

CAUTION:

The joint on the wheel side cannot be disassembled.

1. Before separating joint assembly, put matching marks on drive shaft and joint assembly.
2. Separate joint assembly with a suitable tool.

Be careful not to damage threads on drive shaft.

3. Remove boot bands.
4. Draw out boot.

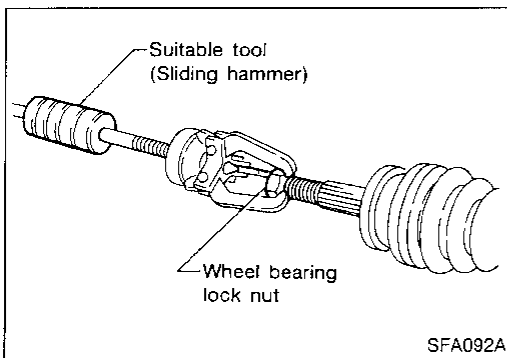

REAR AXLE

Drive Shaft (Cont'd)

INSPECTION

Thoroughly clean all parts in cleaning solvent, and dry with compressed air. Check parts for evidence of deformation or other damage.

Drive shaft

Replace drive shaft if it is twisted or cracked.

Boot

Check boot for fatigue, cracks, or wear. Replace boot with new boot bands.

Joint assembly (Final drive side)

- Replace any parts of double offset joint which show signs of scorching, rust, wear or excessive play.
- Check serration for deformation. Replace if necessary.
- Check slide joint housing for any damage. Replace if necessary.

Joint assembly (Wheel side)

Replace joint assembly if it is deformed or damaged.

ASSEMBLY

- After drive shaft has been assembled, ensure that it moves smoothly over its entire range without binding.
- Use NISSAN GENUINE GREASE or equivalent after every overhaul.

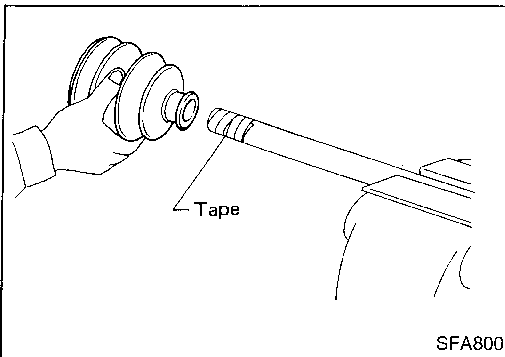

Wheel side

1. Install boot and new small boot band on drive shaft.

Cover drive shaft serration with tape so as not to damage boot during installation.

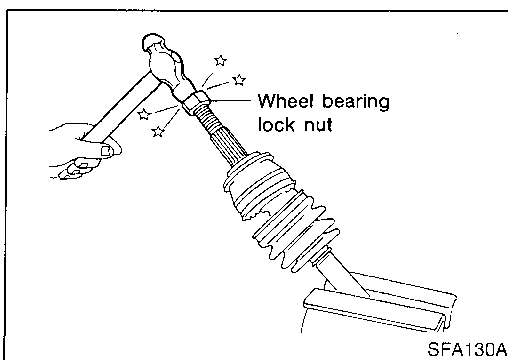

2. Set joint assembly onto drive shaft by lightly tapping it. Install joint assembly securely, ensuring marks which were made during disassembly are properly aligned.

REAR AXLE

Drive Shaft (Cont'd)

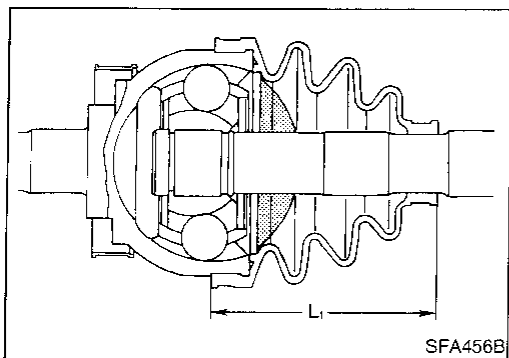

3. Pack drive shaft with specified amount of grease.
Specified amount of grease:
113 - 123 g (3.99 - 4.34 oz)
4. Make sure that boot is properly installed on the drive shaft groove.
Set boot so that it does not swell and deform when its length is " L_1 ".
Length " L_1 ":
96 - 98 mm (3.78 - 3.86 in)

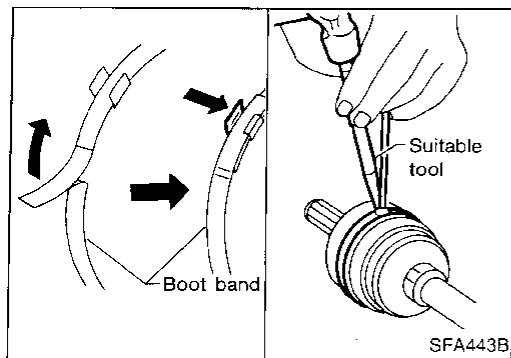

5. Lock new larger and smaller boot bands securely with a suitable tool.

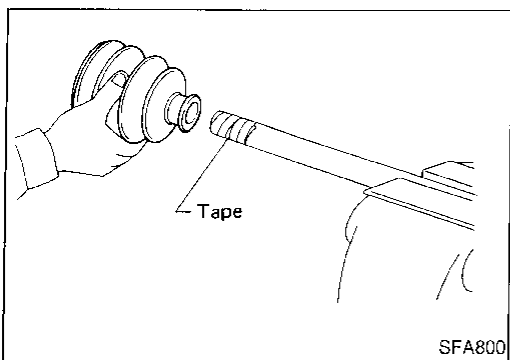

Final drive side

1. Install boot and new small boot band on drive shaft.
Cover drive shaft serration with tape so as not to damage boot during installation.

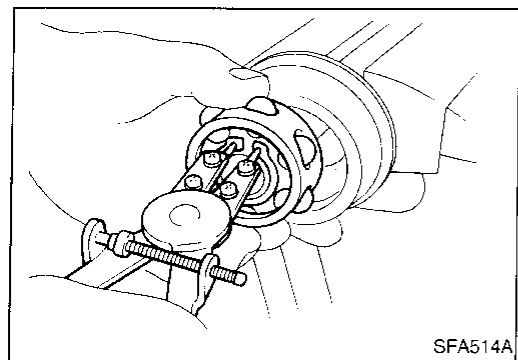

2. Install ball cage, inner race and balls as a unit, making sure the marks which were made during disassembly are properly aligned.
3. Install new snap ring.

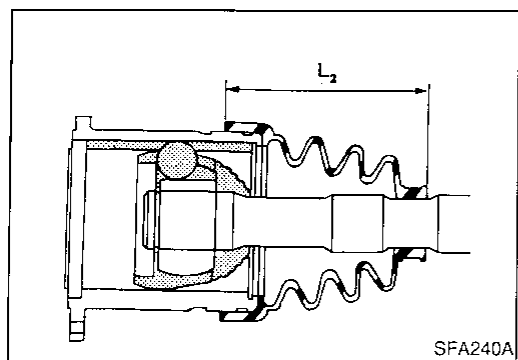

4. Pack drive shaft with specified amount of grease.
Specified amount of grease:
165 - 175 g (5.82 - 6.17 oz)
5. Install slide joint housing, then install new stopper ring.
6. Make sure that boot is properly installed on the drive shaft groove.
Set boot so that it does not swell and deform when its length is " L_2 ".
Length " L_2 ":
93 - 95 mm (3.66 - 3.74 in)
7. Lock new larger and smaller boot bands securely with a suitable tool.

REAR SUSPENSION

SEC. 380•396•430•431

CAUTION:

Do not jack up at lower link.
When installing rubber parts, final tightening must be carried out under unladen condition* with tires on ground.

* Fuel, radiator coolant and engine oil full.
Spare tire, jack, hand tools and mats in designated positions.

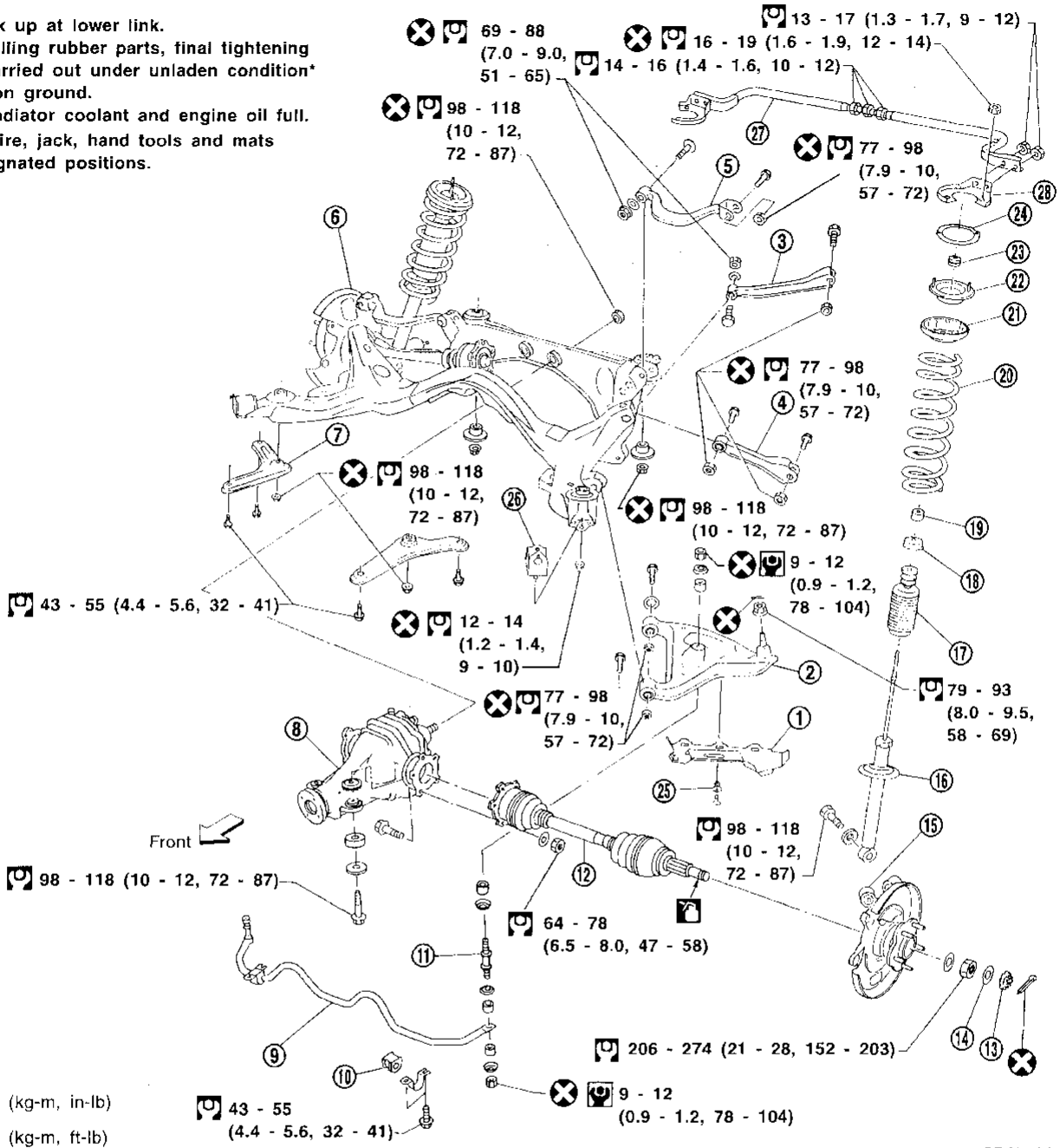

SRA779A

- | | | |
|---------------------|------------------|---------------------------|
| ① Protector | ⑪ Connecting rod | ⑳ Coil spring |
| ② Lower link | ⑫ Drive shaft | ㉑ Upper rubber seat |
| ③ Lateral link | ⑬ Adjusting cap | ㉒ Upper spring seat |
| ④ Front upper link | ⑭ Insulator | ㉓ Bushing |
| ⑤ Rear upper link | ⑮ Axle housing | ㉔ Gasket |
| ⑥ Suspension member | ⑯ Shock absorber | ㉕ Clip |
| ⑦ Member stay | ⑰ Bound bumper | ㉖ Dynamic damper assembly |
| ⑧ Final drive | ⑱ Plate | ㉗ Rear tower bar |
| ⑨ Stabilizer bar | ⑲ Bushing | ㉘ Bracket |
| ⑩ Bushing | | |

REAR SUSPENSION

Removal and Installation

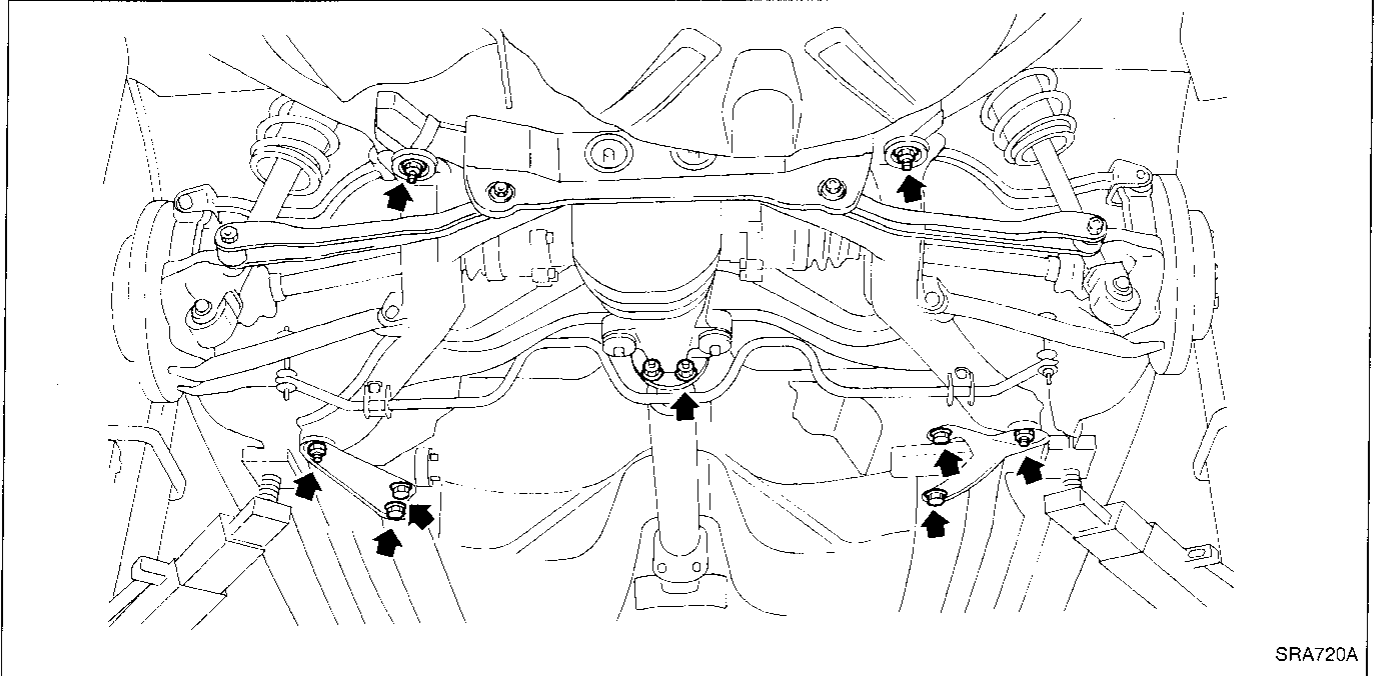

GI
MA
EM
LC
EC
FE
AT

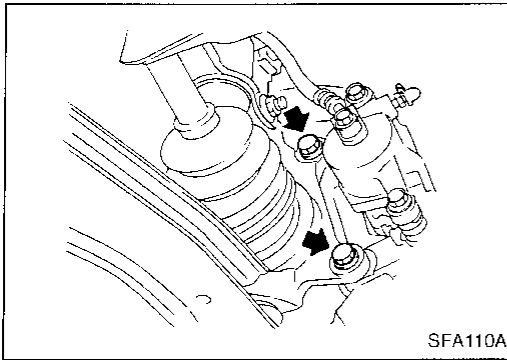

CAUTION:

Before removing the rear suspension assembly, disconnect the ABS wheel sensor from the assembly. Then move it away from the rear suspension assembly.

Failure to do so may result in the sensor wires being damaged and the sensor becoming inoperative.

- Remove exhaust tube.
- Disconnect propeller shaft rear end.
- Disconnect hand brake wire front end.
- Remove brake caliper assembly.

Brake line need not be disconnected from brake caliper. Be careful not to depress brake pedal, or piston will pop out. Do not pull or twist brake hose.

PD
FA
RA

BR
ST

RS

BT

HA

EL

DX

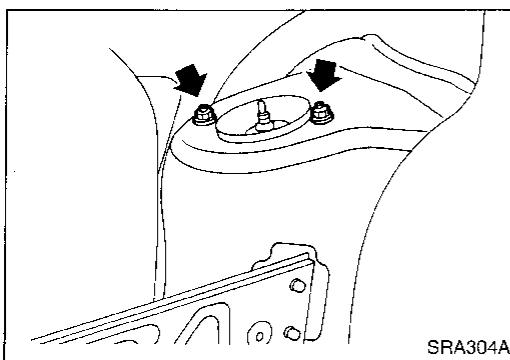

- Remove upper end nuts of shock absorber.

Do not remove piston rod lock nut.

- Remove suspension member fixing nuts. Then draw out rear axle and rear suspension assembly.

REAR SUSPENSION

Coil Spring and Shock Absorber

REMOVAL

Remove shock absorber upper and lower fixing nuts.

Do not remove piston rod lock nut on vehicle.

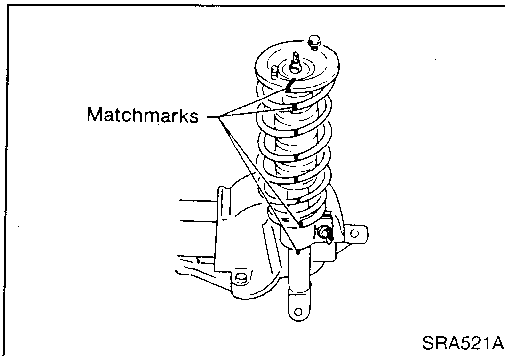

DISASSEMBLY

- Put matchmarks on coil spring and shock absorber.

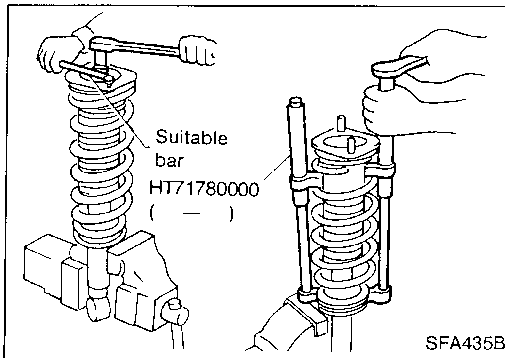

1. Set shock absorber in vise with attachment, then **loosen** piston rod lock nut.

Do not remove piston rod lock nut at this time.

2. Compress spring with Tool so that the shock absorber upper spring seat can be turned by hand.
3. Remove piston rod lock nut.

INSPECTION

Shock absorber assembly

- Check for smooth operation through a full stroke, both compression and extension.
- Check for oil leakage occurring on welded or gland packing portions.
- Check piston rod for cracks, deformation or other damage. Replace if necessary.

Upper rubber seat and bushing

Check rubber parts for deterioration or cracks. Replace if necessary.

Coil spring

Check for cracks, deformation or other damage. Replace if necessary.

REAR SUSPENSION

Coil Spring and Shock Absorber (Cont'd)

ASSEMBLY

- Install upper spring seat with its cutout facing the outer side of vehicle.

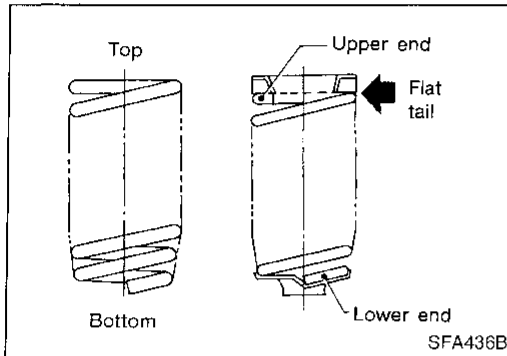
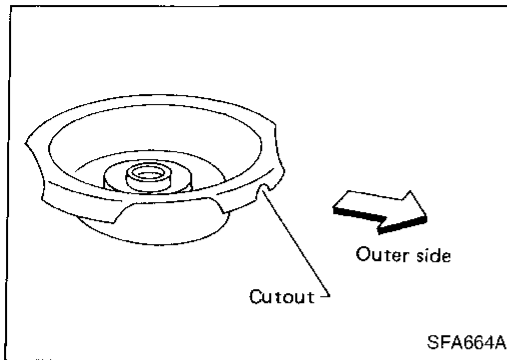

- When installing coil springs, be careful not to reverse top and bottom direction. (Top end is flat.)
- When installing coil spring on shock absorber, it must be positioned as shown in figure at left.

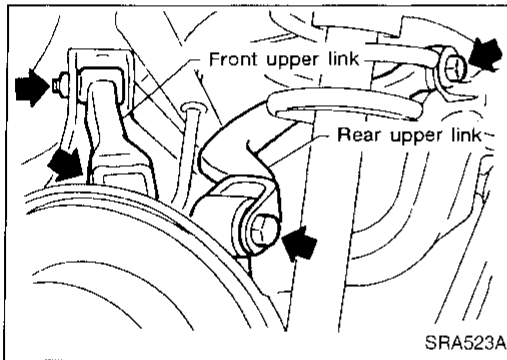

Multi-link and Lower Ball Joint

REMOVAL AND INSTALLATION

- Remove upper link.

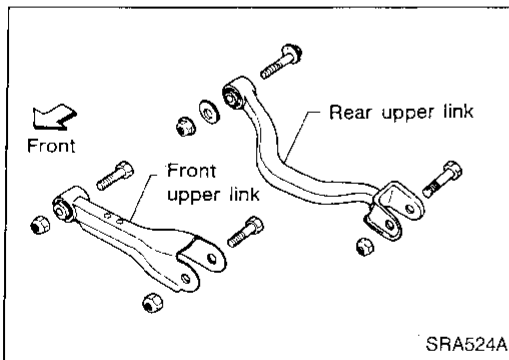

- Install upper link.

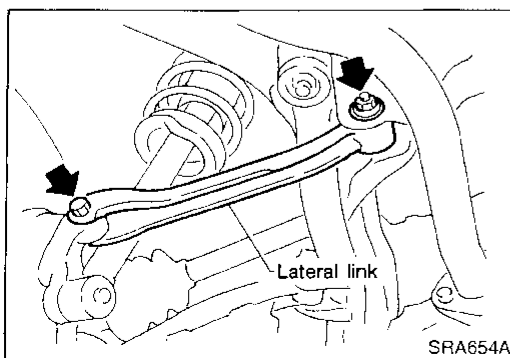

- Remove lateral link.

GI

MA

EM

LC

EC

FE

AT

PD

FA

RA

BR

ST

RS

BT

HA

EL

DX

REAR SUSPENSION

Multi-link and Lower Ball Joint (Cont'd)

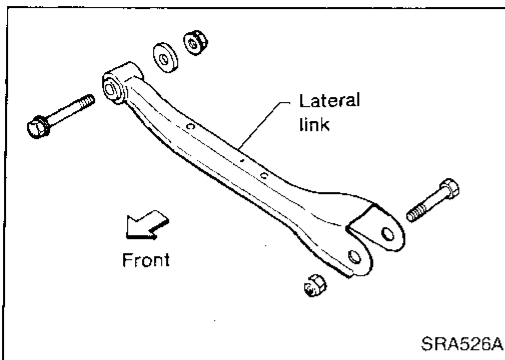

- Install lateral link.

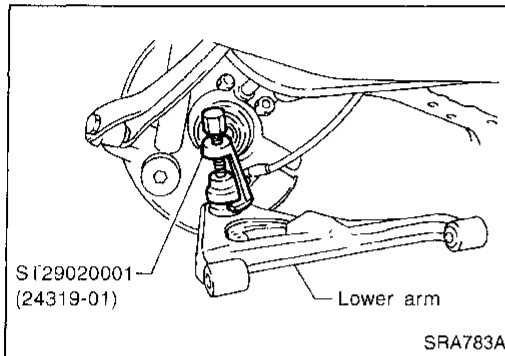

- Remove lower arm with Tool.

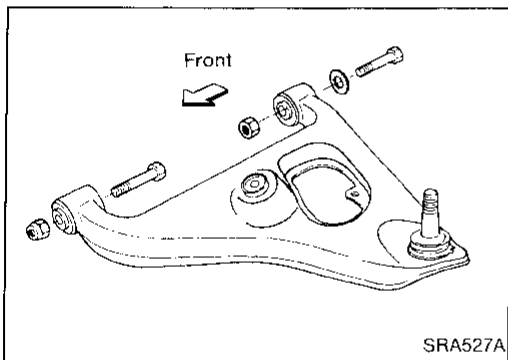

- Install lower arm.

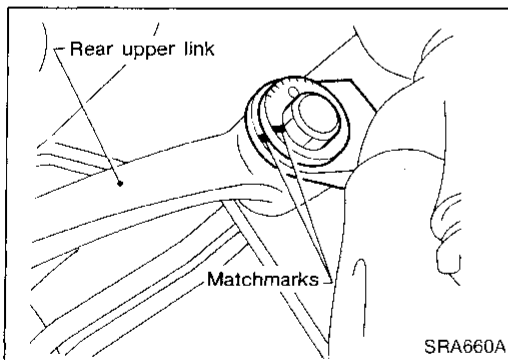

Before removing, put matchmarks on adjusting bolt.

- When installing, final tightening must be done under unladen condition with tires on ground.

REAR SUSPENSION

Multi-link and Lower Ball Joint (Cont'd)

- After installation, check wheel alignment. Refer to Rear Wheel Alignment in ON-VEHICLE SERVICE (RA-6).

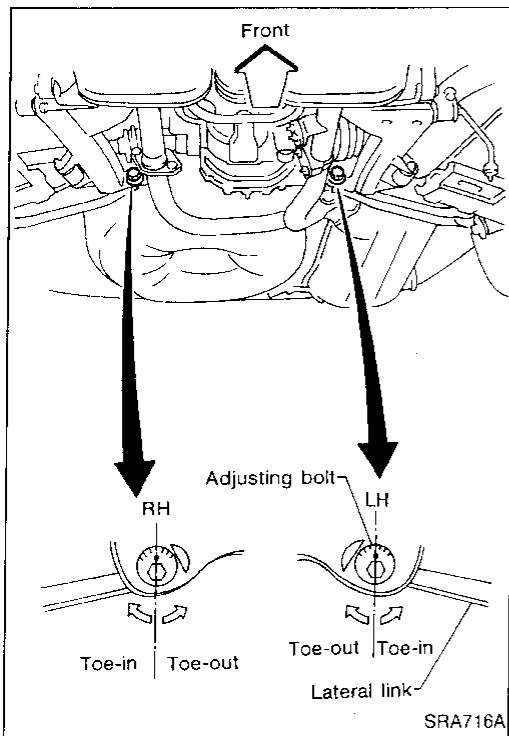

INSPECTION

Rear suspension member

Replace suspension member assembly if cracked or deformed or if any part (insulator, for example) is damaged.

Upper, lower and lateral links

Replace upper, lower or lateral link as required if cracked or deformed or if bushing is damaged.

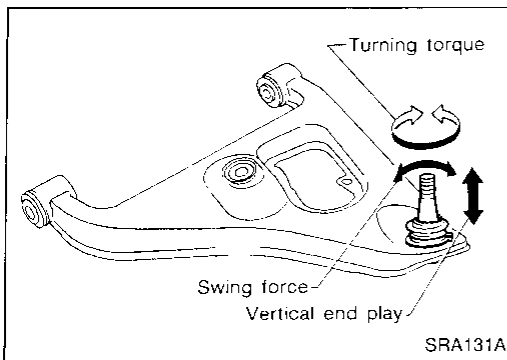

Suspension lower ball joint

- Measure swing force, turning torque and vertical end play in axial direction. (Use same measurement procedures as that of FA section.)
- If ball stud is worn, play in axial direction is excessive, or joint is hard to swing, replace lower arm.

Ball joint specifications	Swing force	7.8 - 78.4 N (0.8 - 8.0 kg, 1.8 - 17.6 lb)
	Turning torque	0.5 - 4.9 N·m (5 - 50 kg·cm, 4.3 - 43.4 in·lb)
	Vertical end play	0 mm (0 in)

GI
MA
EM
LG
EC
FE
AT
PD
FA
RA
BR
ST
RS
BT
HA
EL
DX

REAR SUSPENSION

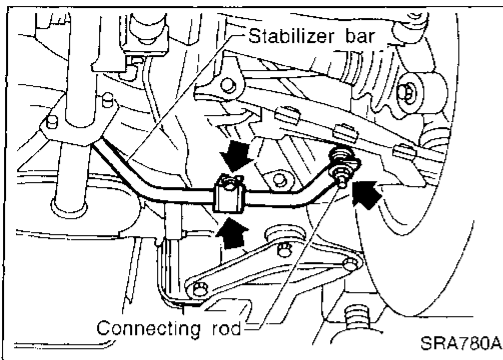

Stabilizer Bar

REMOVAL

Remove connecting rod and clamp.

INSPECTION

- Check stabilizer bar for deformation or cracks. Replace if necessary.
- Check rubber bushings for deterioration or cracks. Replace if necessary.

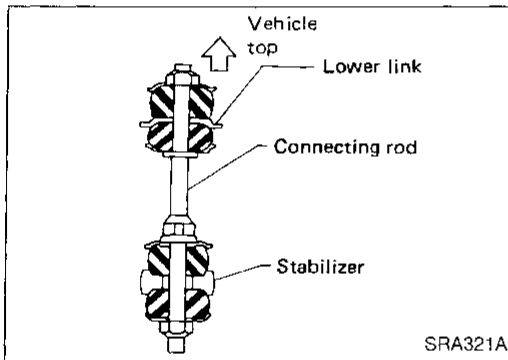

INSTALLATION

When installing connecting rod, make sure direction is correct (as shown at left).

SERVICE DATA AND SPECIFICATIONS (SDS)

General Specifications

Suspension type	5-link type rigid with coil spring
Shock absorber type	Double-acting hydraulic
Stabilizer	Standard equipment

Inspection and Adjustment

WHEEL ALIGNMENT (Unladen*)

Camber	Minimum	-0°15' (-0.25°)
	Nominal	-0°45' (-0.75°)
	Maximum	-1°15' (-1.25°)
Total toe-in	Minimum	0 (0)
	Nominal	2.5 (0.098)
	Maximum	5 (0.20)
Angle (left plus right)	Minimum	0' (0.00°)
	Nominal	14' (0.23°)
	Maximum	28' (0.47°)

*: Fuel, radiator coolant and engine oil full. Spare tire, jack, hand tools and mats in designated positions.

WHEEL RUNOUT (Radial and lateral)

Wheel type	Radial runout	Lateral runout
Aluminum wheel	mm (in)	0.3 (0.012) or less

LOWER BALL JOINT

Swing force (Measuring point: cotter pin hole of ball stud)	N (kg, lb)	7.8 - 78.4 (0.8 - 8.0, 1.8 - 17.6)
Turning torque	N-m (kg-cm, in-lb)	0.5 - 4.9 (5 - 50, 4.3 - 43.4)
Vertical end play	mm (in)	0 (0)

WHEEL BEARING

Wheel bearing axial end play mm (in)	0.05 (0.0020) or less
Wheel bearing lock nut Tightening torque N-m (kg-m, ft-lb)	206 - 274 (21 - 28, 152 - 203)

DRIVE SHAFT

Joint type		
Final drive side		DS90
Wheel side		ZF100
Grease		Nissan genuine grease or equivalent
Specified amount of grease	g (oz)	
Final drive side		165 - 175 (5.82 - 6.17)
Wheel side		113 - 123 (3.99 - 4.34)
Boot length	mm (in)	
Final drive side (L ₂)		93 - 95 (3.66 - 3.74)
Wheel side (L ₁)		96 - 98 (3.78 - 3.86)

Final drive side

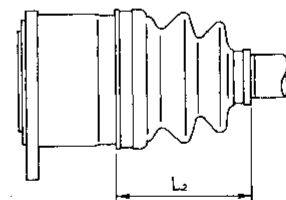

Wheel drive side

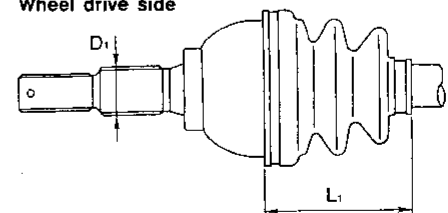

SRA668A