

# STEERING SYSTEM

## SECTION **ST**

GI

MA

EM

LC

EC

FE

AT

PD

FA

RA

BR

**ST**

RS

BT

HA

EL

IDX

## CONTENTS

<b>PRECAUTIONS AND PREPARATION</b> .....2	<b>POWER STEERING GEAR AND LINKAGE</b> ..... 14
Precautions .....2	Removal and Installation ..... 14
Special Service Tools .....2	Disassembly.....17
Commercial Service Tools .....4	Inspection.....17
<b>ON-VEHICLE SERVICE</b> .....5	Assembly ..... 19
Checking Steering Wheel Play.....5	Adjustment .....24
Checking Neutral Position on Steering Wheel .....5	<b>POWER STEERING OIL PUMP</b> .....26
Front Wheel Turning Angle.....5	Pre-disassembly Inspection.....26
Checking Gear Housing Movement .....6	Disassembly.....26
Adjusting Rack Retainer.....6	Inspection.....27
Checking and Adjusting Drive Belts (For power steering) .....6	Assembly ..... 27
Checking Fluid Level .....6	<b>TWIN ORIFICE POWER STEERING SYSTEM</b> .....29
Checking Fluid Leakage.....7	Hydraulic Circuit.....29
Bleeding Hydraulic System.....7	Wiring Diagram .....30
Checking Steering Wheel Turning Force (For power steering) .....8	<b>TWIN ORIFICE POWER STEERING SYSTEM —</b>
Checking Hydraulic System.....8	<b>Trouble Diagnoses</b> ..... 32
<b>STEERING WHEEL AND STEERING COLUMN</b> .....10	Precautions ..... 32
Removal.....10	Diagnostic Procedure ..... 33
Installation.....11	Control Unit Inspection Table .....36
Disassembly and Assembly.....12	<b>SERVICE DATA AND SPECIFICATIONS (SDS)</b> .....37
Inspection.....13	General Specifications.....37
	Inspection and Adjustment .....37

# PRECAUTIONS AND PREPARATION

## Precautions

### SUPPLEMENTAL RESTRAINT SYSTEM (SRS) "AIR BAG" AND "SEAT BELT PRE-TENSIONER"

The Supplemental Restraint System "Air Bag" and "Seat Belt Pre-tensioner", used along with a seat belt, help to reduce the risk or severity of injury to the driver and front passenger in a frontal collision. The Supplemental Restraint System consists of air bag modules (located in the center of the steering wheel and on the instrument panel on the passenger side), seat belt pre-tensioners, a diagnosis sensor unit, warning lamp, wiring harness and spiral cable. Information necessary to service the system safely is included in the **RS** section of this Service Manual.

#### WARNING:

- To avoid rendering the SRS inoperative, which could increase the risk of personal injury or death in the event of a collision which would result in air bag inflation, all maintenance must be performed by an authorized INFINITI dealer.
- Improper maintenance, including incorrect removal and installation of the SRS, can lead to personal injury caused by unintentional activation of the system.
- Do not use electrical test equipment on any circuit related to the SRS unless instructed to in this Service Manual. SRS wiring harnesses are covered with yellow insulation either just before the harness connectors or for the complete harness, for easy identification.

### STEERING SYSTEM

- Before disassembly, thoroughly clean the outside of the unit.
- Disassembly should be done in a clean work area. It is important to prevent the internal parts from becoming contaminated by dirt or other foreign matter.
- Place disassembled parts in order, on a parts rack, for easier and proper assembly.
- Use nylon cloths or paper towels to clean the parts; common shop rags can leave lint that might interfere with their operation.
- Before inspection or reassembly, carefully clean all parts with a general purpose, non-flammable solvent.
- Before assembly, apply a coat of recommended ATF\* to hydraulic parts. Vaseline may be applied to O-rings and seals. Do not use any grease.
- Replace all gaskets, seals and O-rings. Avoid damaging O-rings, seals and gaskets during installation. Perform functional tests whenever designated.

\*: Automatic transmission fluid type DEXRON<sup>TM</sup>IIE, DEXRON<sup>TM</sup>III or equivalent.

## Special Service Tools

The actual shapes of Kent-Moore tools may differ from those of special service tools illustrated here.

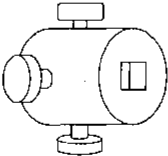
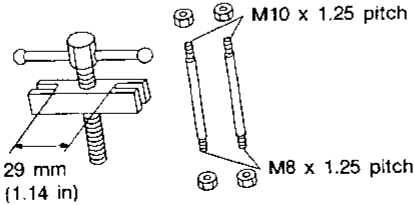
Tool number (Kent-Moore No.) Tool name	Description
KV48103404 ( — ) Torque adapter	<div style="display: flex; justify-content: space-between;"> <div data-bbox="391 1623 451 1648">NT236</div> <div data-bbox="597 1465 764 1619">  </div> <div data-bbox="967 1444 1300 1470">Measuring pinion rotating torque</div> </div>
ST27180001 (J25726-A) Steering wheel puller	<div style="display: flex; justify-content: space-between;"> <div data-bbox="391 1850 451 1875">NT544</div> <div data-bbox="467 1661 878 1864">  </div> <div data-bbox="967 1654 1227 1680">Removing steering wheel</div> </div>

# PRECAUTIONS AND PREPARATION

## Special Service Tools (Cont'd)

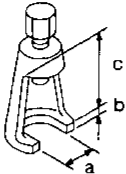
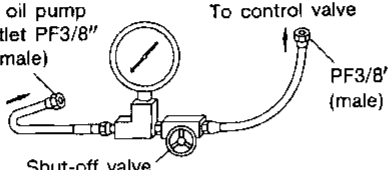
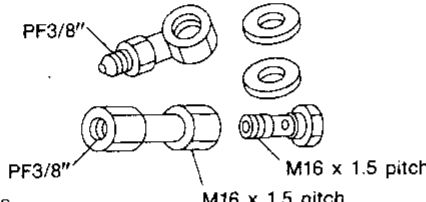
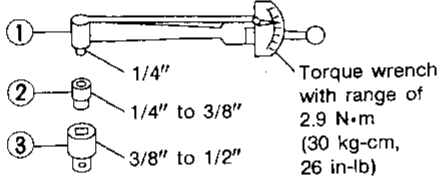
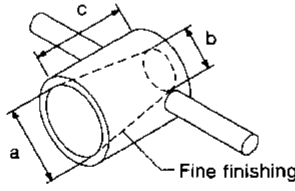
Tool number (Kent-Moore No.) Tool name	Description	
ST29020001 (J24319-01) Pitman arm puller		Removing ball joint  <b>a: 34 mm (1.34 in)</b> <b>b: 6.5 mm (0.256 in)</b> <b>c: 61.5 mm (2.421 in) radius</b>
NT551		
ST27091000 (J26357 and J26357-10) Pressure gauge		Measuring oil pressure
NT547		
KV48102500 (J33914) Pressure gauge adapter		Measuring oil pressure
NT542		
ST3127S000 (See J25765-A) ① GG91030000 (J25765-A) Torque wrench ② HT62940000 ( — ) Socket adapter ③ HT62900000 ( — ) Socket adapter		Measuring turning torque
NT541		
KV48104400 ( — ) Rack seal ring reformer		Reforming teflon ring  <b>a: 50 mm (1.97 in) dia.</b> <b>b: 36 mm (1.42 in) dia.</b> <b>c: 100 mm (3.94 in)</b>
NT550		

GI  
MA  
EM  
LC  
EC  
FE  
AT  
PD  
FA  
RA  
BR  
ST  
RS  
BT  
HA  
EL  
IDX

# PRECAUTIONS AND PREPARATION

## Commercial Service Tools

Tool name	Description
Rear oil seal drift	<div data-bbox="967 243 1187 268" data-label="Text">Installing rear oil seal</div> <div data-bbox="558 281 764 401" data-label="Image"> </div> <div data-bbox="396 422 456 443" data-label="Text">NT063</div> <div data-bbox="967 417 1208 443" data-label="Text"><b>a: 28 mm (1.10 in) dia.</b></div>
Pinion oil seal drift	<div data-bbox="967 447 1203 472" data-label="Text">Installing pinion oil seal</div> <div data-bbox="558 485 764 604" data-label="Image"> </div> <div data-bbox="396 625 456 646" data-label="Text">NT063</div> <div data-bbox="967 621 1208 646" data-label="Text"><b>a: 35 mm (1.38 in) dia.</b></div>
Oil pump attachment	<div data-bbox="967 651 1377 676" data-label="Text">Disassembling and assembling oil pump</div> <div data-bbox="423 684 906 898" data-label="Diagram"> </div> <div data-bbox="396 936 456 957" data-label="Text">NT179</div> <div data-bbox="967 932 1094 957" data-label="Text">Unit: mm (in)</div>

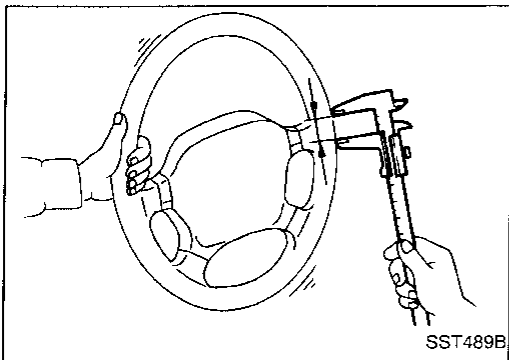

### Checking Steering Wheel Play

- With wheels in a straight-ahead position, check steering wheel play.

**Steering wheel play:**  
35 mm (1.38 in) or less

- If it is not within specification, check the following for loose or worn components.

**Steering gear assembly**  
**Steering column**  
**Front suspension and axle**

GI

MA

EM

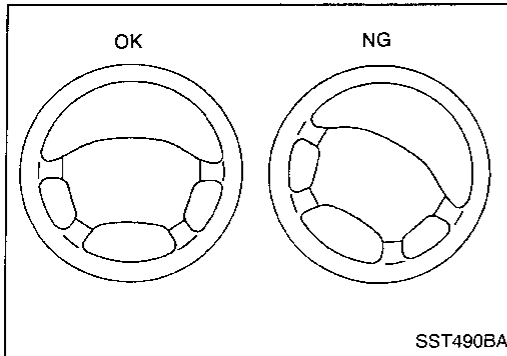

### Checking Neutral Position on Steering Wheel

#### Pre-checking

- Make sure that wheel alignment is correct.

**Wheel alignment:**  
Refer to SDS in FA section.

- Verify that the steering gear is centered before removing the steering wheel.

LC

EC

FE

#### Checking

1. Check that the steering wheel is in the neutral position when driving straight ahead.
2. If it is not in the neutral position, remove the steering wheel and reinstall it correctly.
3. If the neutral position is between two teeth, loosen tie-rods lock nuts. Turn the tie-rods by the same amount in opposite directions on both left and right sides.

AT

PD

FA

RA

BR

ST

RS

BT

HA

EL

IDX

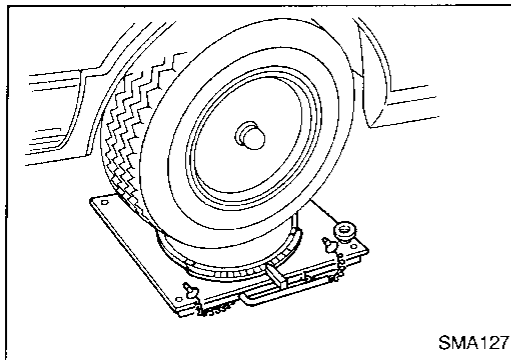

### Front Wheel Turning Angle

1. Rotate steering wheel all the way right and left; measure turning angle.

**Turning angle of full turns:**  
Refer to SDS in FA section.

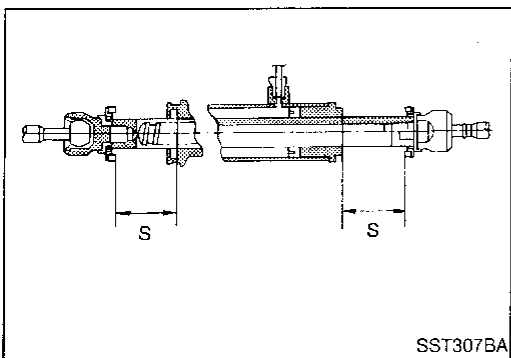

2. If it is not within specification, check rack stroke.

**Rack stroke "S":**  
Refer to SDS (ST-37).

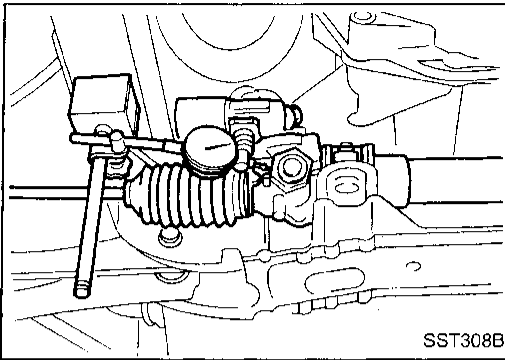

## Checking Gear Housing Movement

1. Check the movement of steering gear housing during stationary steering on a dry paved surface.
    - Apply a force of 49 N (5 kg, 11 lb) to steering wheel to check the gear housing movement.
- Turn off ignition key while checking.

**Movement of gear housing:**  
 $\pm 2$  mm ( $\pm 0.08$  in) or less

2. If movement exceeds the limit, replace mount insulator after confirming proper installation of gear housing clamps.

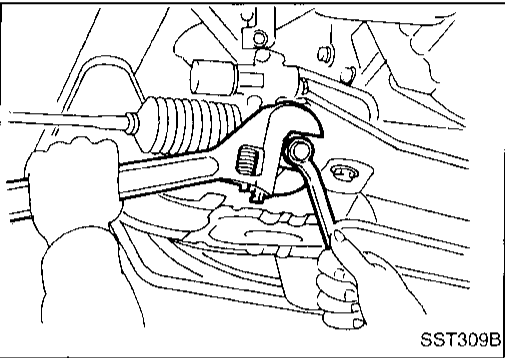

## Adjusting Rack Retainer

- Perform this driving test on a flat road.
1. Check whether vehicle moves in a straight line when steering wheel is released.
  2. Check whether steering wheel returns to neutral position when steering wheel is released from a slightly turned (approx. 20°) position.
- If any abnormality is found, correct it by resetting adjusting screw.

## Checking and Adjusting Drive Belts (For power steering)

Refer to "Checking Drive Belts" in MA section.

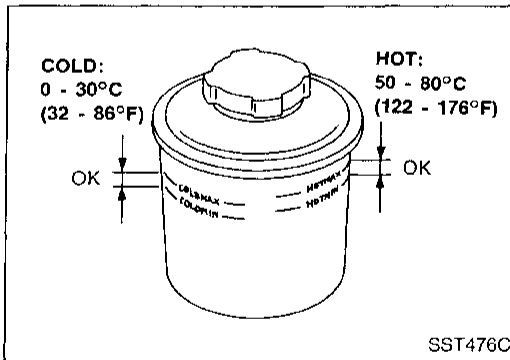

## Checking Fluid Level

Check fluid level with dipstick on reservoir cap. Use "HOT" range at fluid temperatures from 50 to 80°C (122 to 176°F). Use "COLD" range at fluid temperatures from 0 to 30°C (32 to 86°F).

### CAUTION:

- Do not overfill.
- Recommended fluid is Automatic Transmission Fluid type DEXRON™IIIE, DEXRON™III or equivalent.

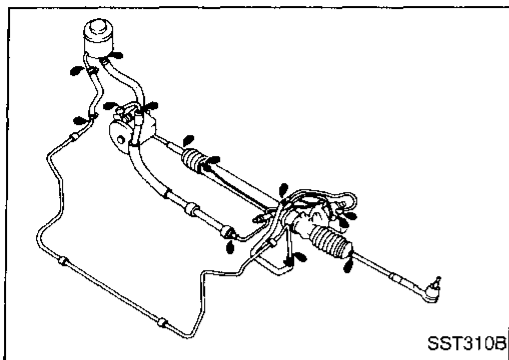

## Checking Fluid Leakage

Check the lines for improper attachment and for leaks, cracks, damage, loose connections, chafing or deterioration.

1. Run engine at idle speed or 1,000 rpm.

**Make sure temperature of fluid in oil tank rises to 60 to 80°C (140 to 176°F).**

2. Turn steering wheel right-to-left several times.
3. Hold steering wheel at each "lock" position for five seconds and carefully check for fluid leakage.

### CAUTION:

**Do not hold the steering wheel in a locked position for more than 15 seconds.**

4. If fluid leakage at connectors is noticed, loosen flare nut and then retighten.

**Do not overtighten connector as this can damage O-ring, washer and connector.**

5. Check rack boots for accumulation of power steering fluid.

## Bleeding Hydraulic System

1. Raise front end of vehicle until wheels clear ground.
2. Add fluid into oil tank to specified level. Meanwhile, quickly turn steering wheel fully to right and left and lightly touch steering stoppers.

Repeat steering wheel operation until fluid level no longer decreases.

3. Start engine.  
Repeat step 2 above.
- Incomplete air bleeding will cause the following to occur. When this happens, bleed air again.

- a. Generation of air bubbles in reservoir tank
- b. Generation of clicking noise in oil pump
- c. Excessive buzzing in oil pump

Fluid noise may occur in the valve or oil pump. This is common when the vehicle is stationary or while turning the steering wheel slowly. This does not affect performance or durability of the system.

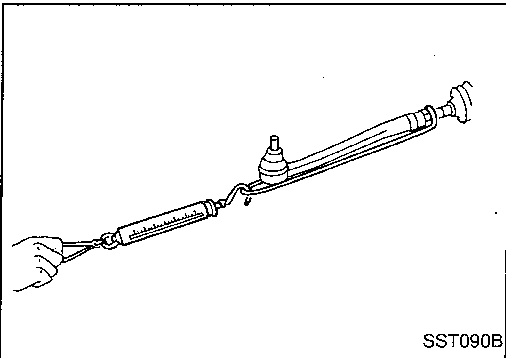
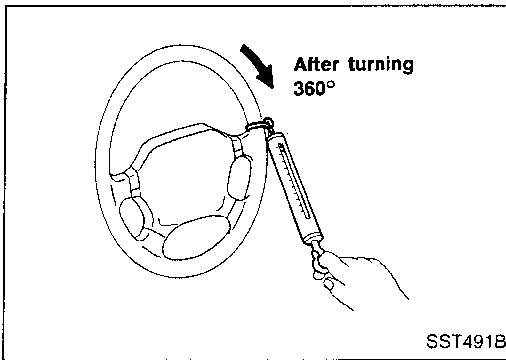

## Checking Steering Wheel Turning Force (For power steering)

1. Park vehicle on a level, dry surface and set parking brake.
2. Start engine.
3. Bring power steering fluid up to adequate operating temperature. [Make sure temperature of fluid is approximately 60 to 80°C (140 to 176°F).]

**Tires need to be inflated to normal pressure.**

4. Check steering wheel turning force when steering wheel has been turned 360° from the neutral position.

**Steering wheel turning force:**

**39 N (4 kg, 9 lb) or less**

5. If steering wheel turning force is out of specification, check rack sliding force.
  - a. Disconnect steering column lower joint and knuckle arms from the gear.
  - b. Start and run engine at idle to make sure steering fluid has reached normal operating temperature.
  - c. While pulling tie-rod slowly in the  $\pm 11.5$  mm ( $\pm 0.453$  in) range from the neutral position, make sure rack sliding force is within specification.

**Rack sliding force:**

**226 - 284 N (23 - 29 kg, 51 - 64 lb)**

- d. Check sliding force outside above range.

**Rack sliding force:**

**Not more than 294 N (30 kg, 66 lb)**

6. If rack sliding force is not within specification, overhaul steering gear assembly.

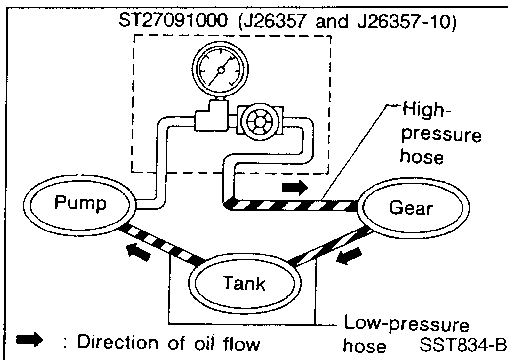

## Checking Hydraulic System

Before starting, check belt tension, driving pulley and tire pressure.

1. Set Tool. Open shut-off valve. Then bleed air. (See "Bleeding Hydraulic System".)
2. Run engine.

**Make sure temperature of fluid in tank rises to 60 to 80°C (140 to 176°F).**

**WARNING:**

**Warm up engine with shut-off valve fully opened. If engine is started with shut-off valve closed, fluid pressure in oil pump increases to maximum. This will raise oil temperature abnormally.**

3. Check pressure with steering wheel fully turned to left and right positions with engine idling at 1,000 rpm.

**CAUTION:**

**Do not hold the steering wheel in a locked position for more than 15 seconds.**

**Oil pump maximum standard pressure:**

**7,649 - 8,238 kPa (78 - 84 kg/cm<sup>2</sup>, 1,109 - 1,194 psi)**



## ON-VEHICLE SERVICE

---

### Checking Hydraulic System (Cont'd)

4. If oil pressure is below the standard pressure, slowly close shut-off valve and check pressure.
  - When pressure reaches standard pressure, gear is damaged.
  - When pressure remains below standard pressure, pump is damaged.

**CAUTION:**

**Do not close shut-off valve for more than 15 seconds.**

5. If oil pressure is higher than standard pressure, check oil pump flow control valve.
6. After checking hydraulic system, remove Tool and add fluid as necessary. Then completely bleed air out of system.

GI

MA

EM

LC

EC

FE

AT

PD

FA

RA

BR

**ST**

RS

BT

HA

EL

IDX

# STEERING WHEEL AND STEERING COLUMN

SEC. 484•488

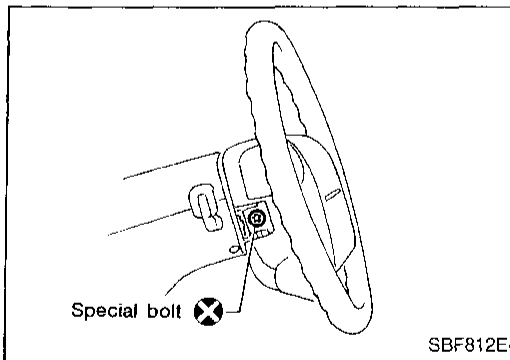
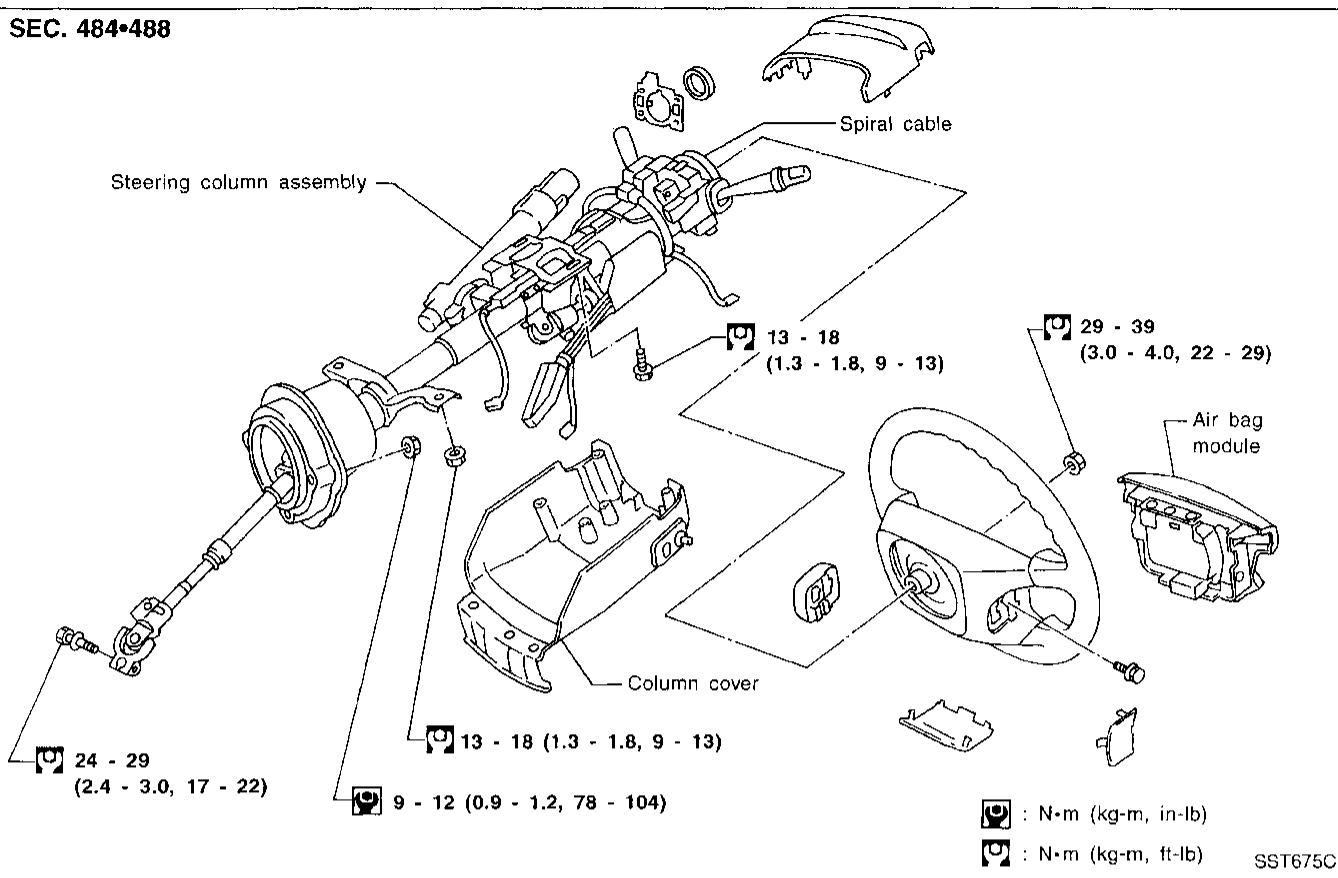

## Removal

### STEERING WHEEL

- Remove air bag module and spiral cable. Refer to RS section ("Removal — Air Bag Module and Spiral Cable", "SUPPLEMENTAL RESTRAINT SYSTEM").

# STEERING WHEEL AND STEERING COLUMN

## Removal (Cont'd)

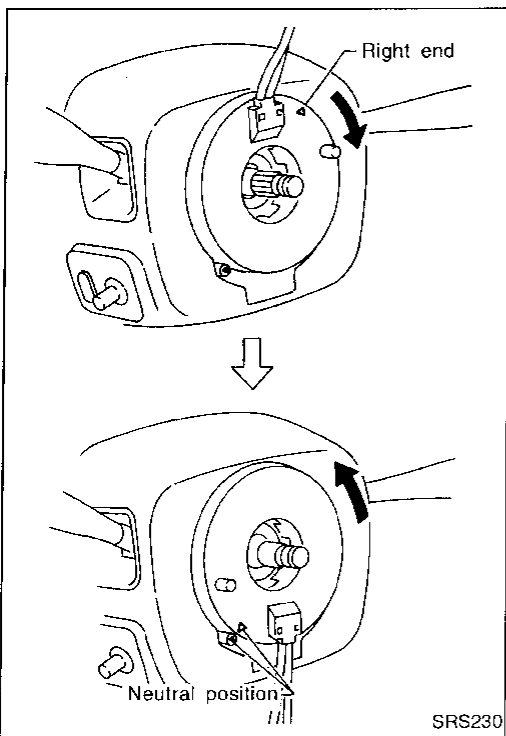

- Align spiral cable correctly when installing steering wheel.
- a. Set the front wheels in the straight-ahead position.
- b. Make sure that the spiral cable is in the neutral position. The neutral position is detected by turning left about 2.5 or 3.5 revolutions from the right end position. Align the two marks (X).

### CAUTION:

- The spiral cable may snap due to steering operation if the cable is installed in an improper position. Also, with the steering linkage disconnected, the cable may snap by turning the steering wheel beyond the limited number of turns. (The spiral cable can be turned up to about 2.5 or 3.5 turns from the neutral position to both the right and left. The number of turns depends on the spiral cable type. Always confirm the number indicated on the caution label attached to the spiral cable before starting work.)
- Always work from the side of air bag module.

GI

MA

EM

LC

EC

FE

AT

- Remove steering wheel with Tool.

PD

FA

RA

BR

ST

RS

BT

HA

EL

IDX

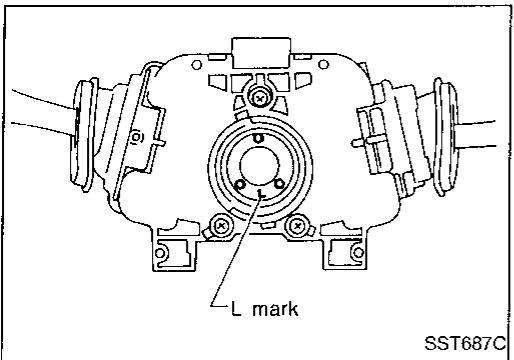
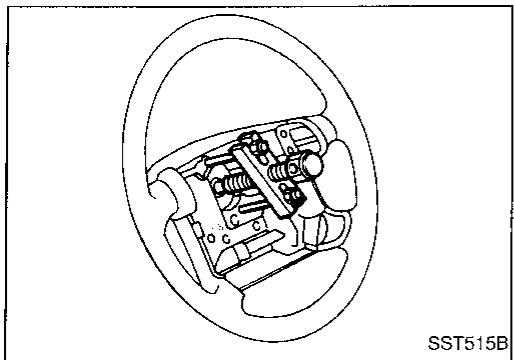

## Installation

### STEERING WHEEL

Place combination switch assembly with the L-mark side facing down.

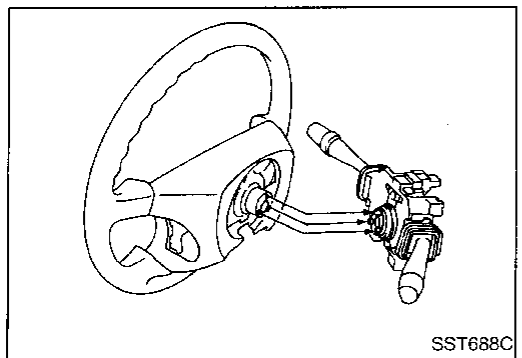

Align the protruding portions of combination switch assembly with their corresponding holes in steering wheel, then install steering wheel. Refer to the figure at left.

# STEERING WHEEL AND STEERING COLUMN

## Installation (Cont'd)

### STEERING COLUMN

- When installing steering column, fingertighten all lower bracket and clamp retaining bolts; then tighten them securely. Do not apply undue stress to steering column.
- When attaching coupling joint, be sure tightening bolt faces cutout portion.

#### CAUTION:

After installation, turn steering wheel to make sure it moves smoothly. Ensure the number of turns are the same from straight forward position to left and right locks.

Be sure that the steering wheel is in a neutral position when driving straight ahead.

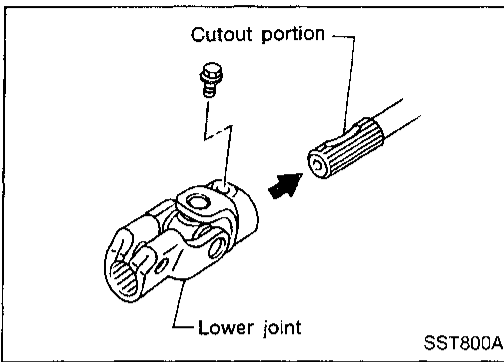

## Disassembly and Assembly

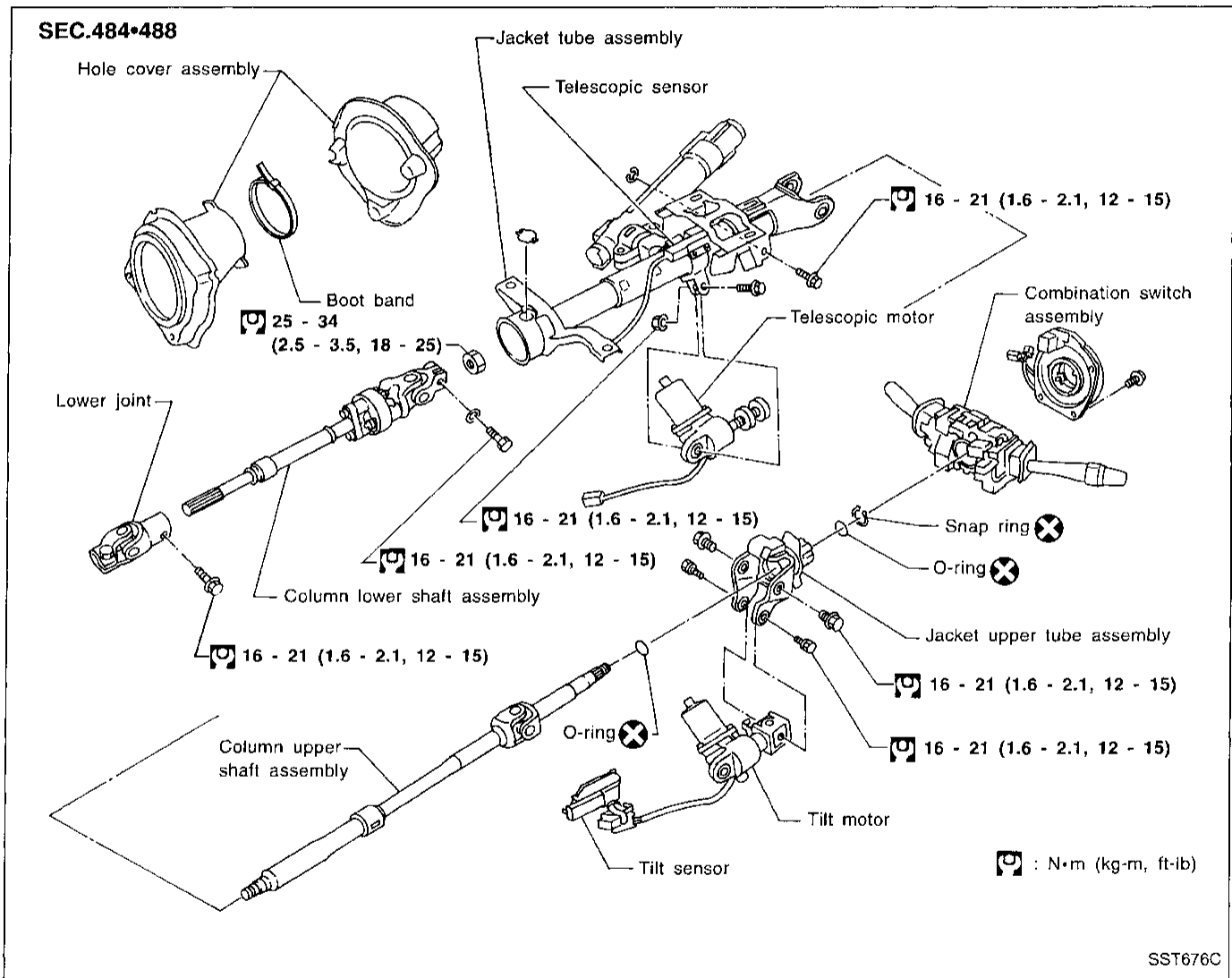

# STEERING WHEEL AND STEERING COLUMN

## Disassembly and Assembly (Cont'd)

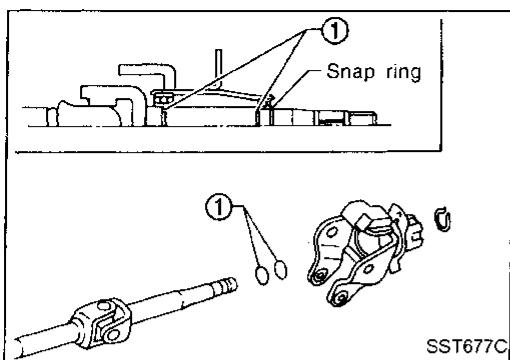

- When disassembling and assembling, unlock steering lock with key.
- a. Install O-rings ① before inserting shaft into jacket tube. Ensure that rounded surface of snap ring faces toward bearing when snap ring is installed.
- b. Install snap ring on upper shaft.

GI  
MA  
EM

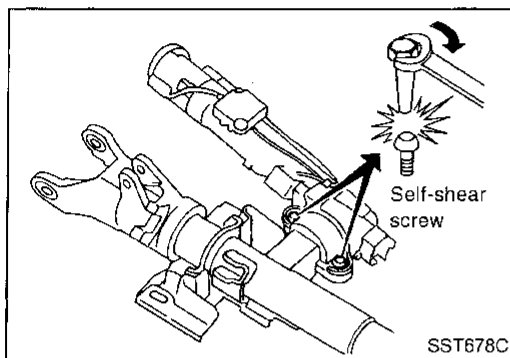

- Steering lock
- a. Break self-shear type screws with a drill or other appropriate tool.
- b. Install new self-shear type screws and then cut off self-shear type screw heads.

LC  
EC

FE

AT

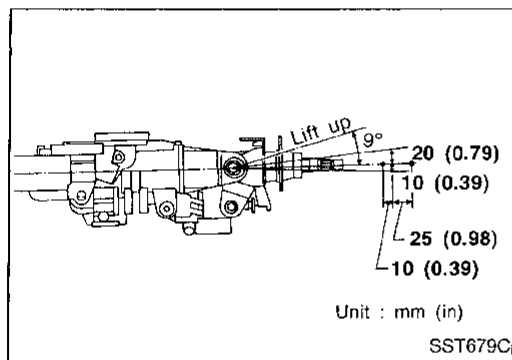

- After installing steering column, check tilt mechanism operation.

PD

FA

RA

BR

ST

RS

BT

HA

EL

IDX

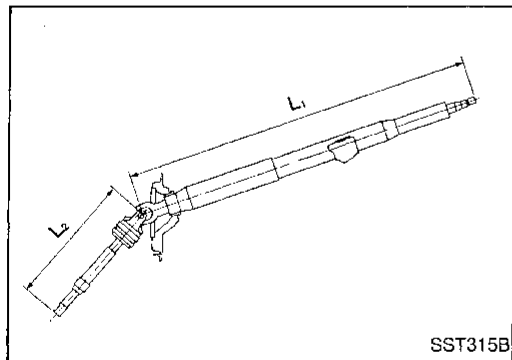

## Inspection

- When steering wheel does not turn smoothly, check the steering column as follows and replace damaged parts.
  - a. Check column bearings for damage or unevenness. Lubricate with recommended multi-purpose grease or replace steering column as an assembly, if necessary.
  - b. Check steering column lower shaft for deformation or breakage. Replace if necessary.
- When the vehicle is involved in a light collision, check steering column length "L<sub>1</sub>" and steering column lower shaft length "L<sub>2</sub>". If it is not within specifications, replace steering column as an assembly.

**Steering column length "L<sub>1</sub>":**

633 - 668 mm (24.92 - 26.30 in)

**Steering column lower shaft length "L<sub>2</sub>":**

334.5 mm (13.17 in)

# POWER STEERING GEAR AND LINKAGE

## Removal and Installation

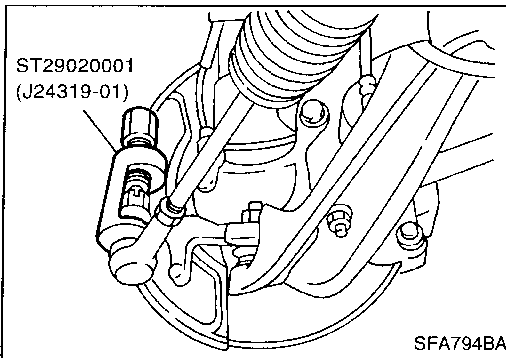
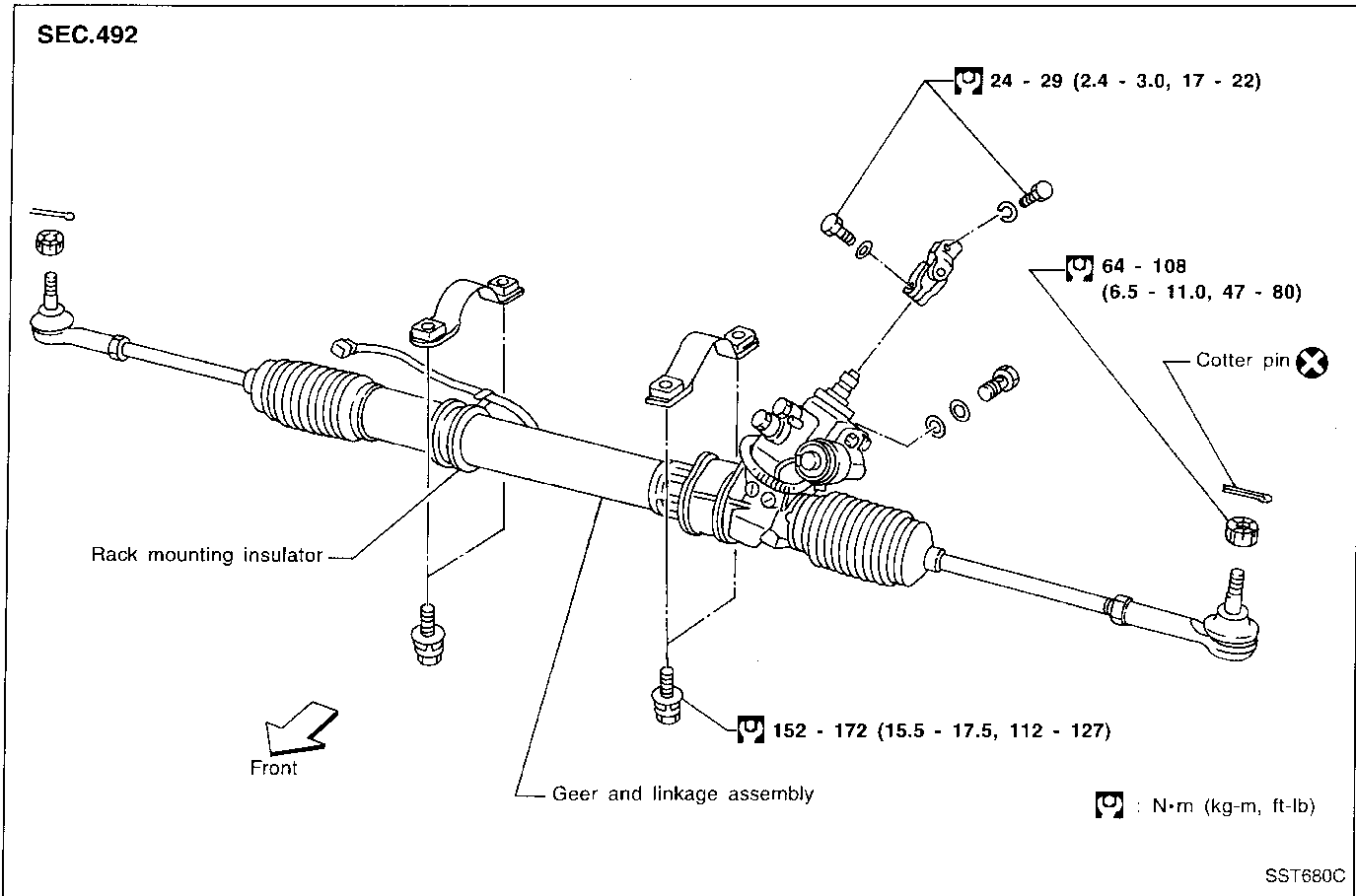

### CAUTION:

The rotation of the spiral cable (SRS "Air bag" component part) is limited. If the steering gear must be removed, set the front wheels in the straight-ahead direction. Do not rotate the steering column while the steering gear is removed.

- Detach tie-rod outer sockets from knuckle arms with Tool.

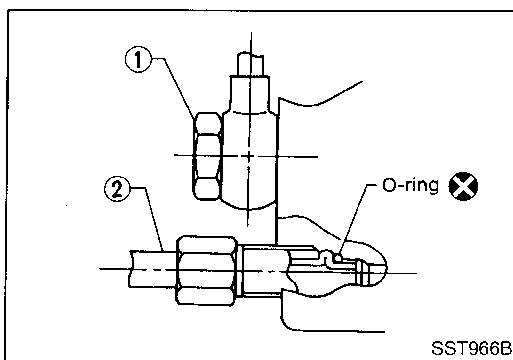

- Install pipe connector.

① Low-pressure side

Ⓜ: 36 - 40 N·m (3.7 - 4.1 kg·m, 27 - 30 ft·lb)

② High-pressure side

Ⓜ: 15 - 25 N·m (1.5 - 2.5 kg·m, 11 - 18 ft·lb)

# POWER STEERING GEAR AND LINKAGE

## Removal and Installation (Cont'd)

- Observe specified tightening torque when tightening high-pressure and low-pressure pipe connectors. Excessive tightening can damage threads or damaged connector O-ring.
- The O-ring in low-pressure pipe connector is larger than that in high-pressure connector. Take care to install the proper O-ring.

GI  
MA  
EM  
LC  
EC  
FE  
AT  
PD  
FA  
RA  
BR  
ST  
RS  
BT  
HA  
EL  
IDX

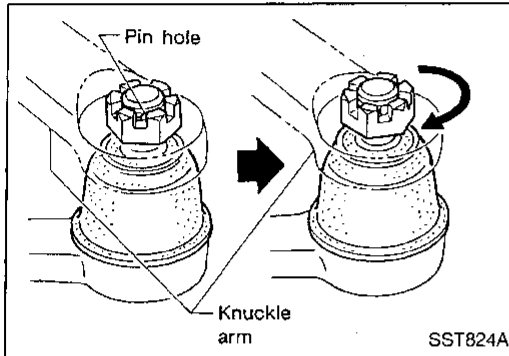

- Initially, tighten nut on tie-rod outer socket and knuckle arm to 64 to 69 N·m (6.5 to 7.0 kg·m, 47 to 51 ft·lb). Then tighten further to align nut groove with first pin hole so that cotter pin can be installed.

**CAUTION:**  
Tightening torque must not exceed 108 N·m (11.0 kg·m, 80 ft·lb).

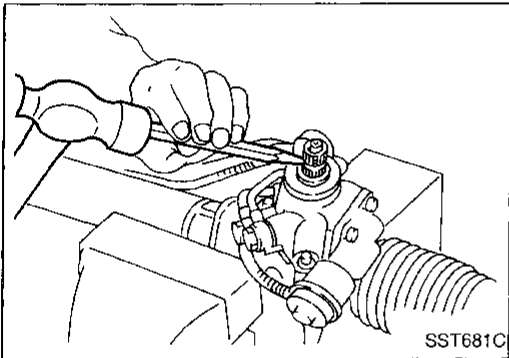

- Before removing lower joint from gear, set gear in neutral (wheels in straight-ahead position). After removing lower joint, put matching marks on pinion shaft and pinion housing to record neutral position.
- To install, set left and right dust boots to equal deflection, and attach lower joint by aligning matchmarks of pinion shaft and pinion housing.

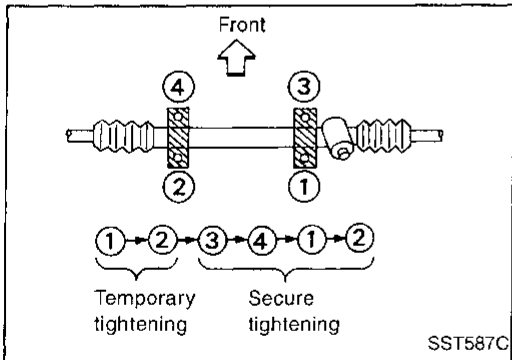

- Tighten gear housing mounting bracket bolts in the order shown.

# POWER STEERING GEAR AND LINKAGE

LHD models  
SEC. 492

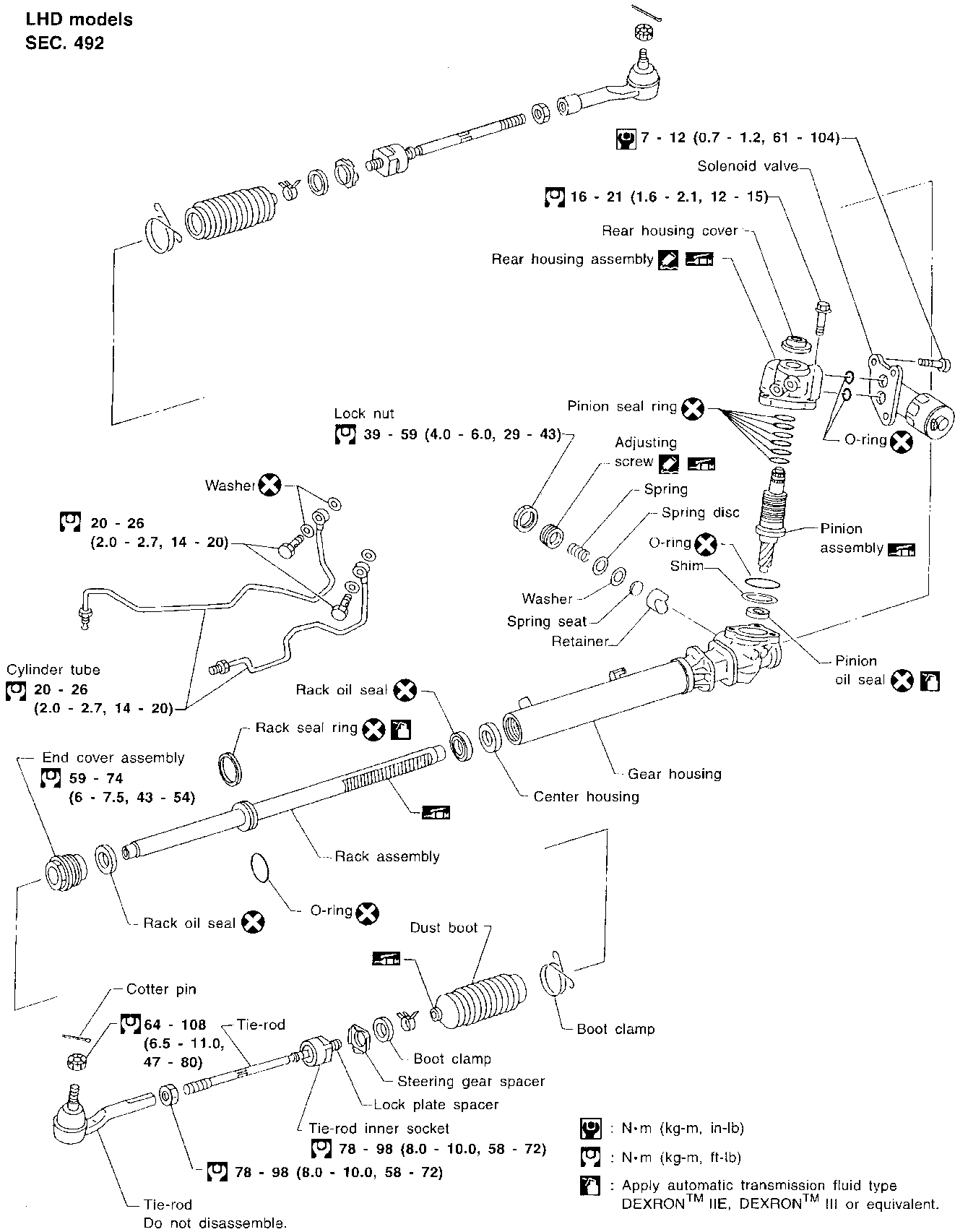



# POWER STEERING GEAR AND LINKAGE

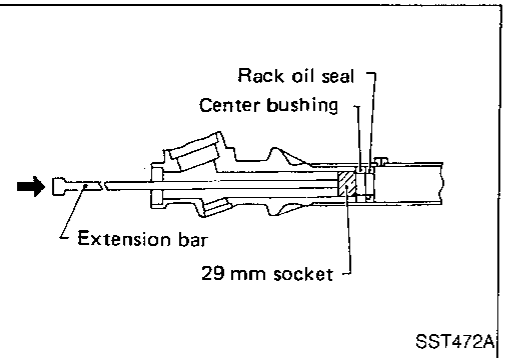
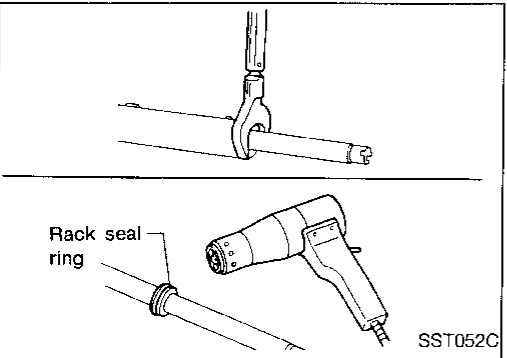
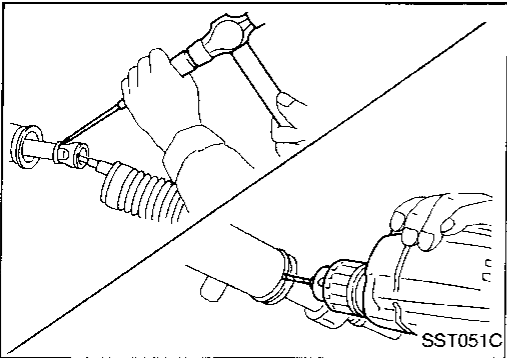
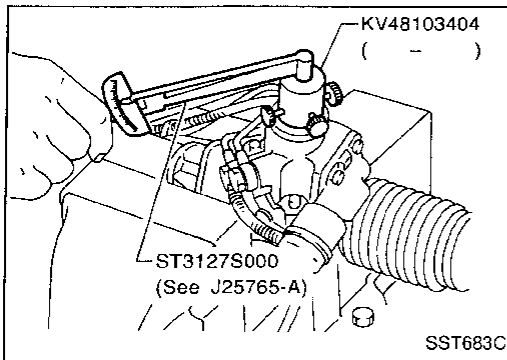

## Disassembly

- Prior to disassembling, measure pinion rotating torque. Record the pinion rotating torque as a reference. Refer to step 12 of "Adjustment" for reference torque data.
    - Before measuring, disconnect cylinder tube and drain fluid.
    - Use soft jaws when holding steering gear housing. Handle gear housing carefully, as it is made of aluminum. Do not grip cylinder in a vise.
  - Remove pinion gear.
    - Be careful not to damage pinion gear when removing pinion seal ring.
  - Remove tie-rod outer sockets and boots.
  - Loosen tie-rod inner socket by prying up staked portion, and remove socket.
  - Remove retainer.
  - Remove pinion assembly.
  - Use a 2 to 2.5 mm (0.079 to 0.098 in) diameter drill to completely remove staked portion of gear housing end.
  - Remove gear housing end cover assembly with Tool.
  - Draw out rack assembly.
  - Remove rack seal ring.
    - Using a heat gun, heat rack seal to approximately 40°C (104°F).
    - Remove rack seal ring.
    - Replace rack seal ring and O-ring with new ones.
- Be careful not to damage rack.**
- Remove center bushing and rack oil seal using tape wrapped socket and extension bar.
- Do not scratch inner surfaces of pinion housing.**

## Inspection

Thoroughly clean all parts in cleaning solvent or automatic transmission fluid type DEXRON™IIIE, DEXRON™III or equivalent. Blow dry with compressed air, if available.

### BOOT

- Check condition of boot. If cracked excessively, replace it.
- Check boots for accumulation of power steering fluid.

### RACK

Thoroughly examine rack gear. If damaged, cracked or worn, replace it.

## POWER STEERING GEAR AND LINKAGE

### Inspection (Cont'd)

#### PINION ASSEMBLY

- Thoroughly examine pinion gear. If pinion gear is damaged, cracked or worn, replace it.
- Check that all bearings roll freely. Ensure that balls, rollers and races are not cracked, pitted or worn. Replace if necessary.

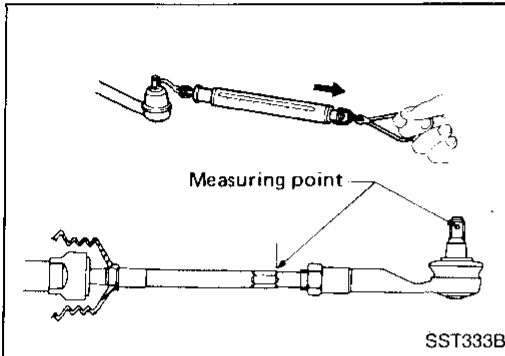

#### TIE-ROD OUTER AND INNER SOCKET

- Check ball joint for swinging force.

**Tie-rod outer ball joint:**

4.9 - 46.1 N

(0.5 - 4.7 kg, 1.1 - 10.4 lb)

**Tie-rod inner ball joint:**

7.8 - 65.7 N

(0.8 - 6.7 kg, 1.8 - 14.8 lb)

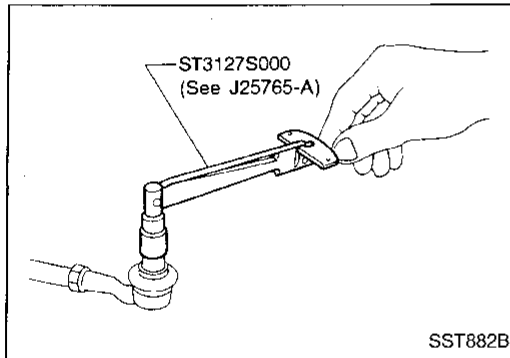

- Check ball joint for rotating torque.

**Tie-rod outer ball joint:**

0.29 - 2.94 N·m

(3.0 - 30.0 kg-cm, 2.6 - 26.0 in-lb)

**Tie-rod inner ball joint:**

1.0 - 7.8 N·m (10 - 80 kg-cm, 8.7 - 69 in-lb)

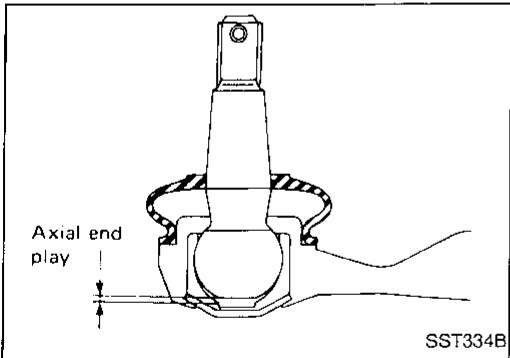

- Check ball joint for axial end play.

**Tie-rod outer ball joint:**

0 mm (0 in)

**Tie-rod inner ball joint:**

0 mm (0 in)

- Check condition of dust cover. If cracked excessively, replace it.

#### CYLINDER TUBES

Check cylinder tubes for scratches or other damage. Replace if necessary.

# POWER STEERING GEAR AND LINKAGE

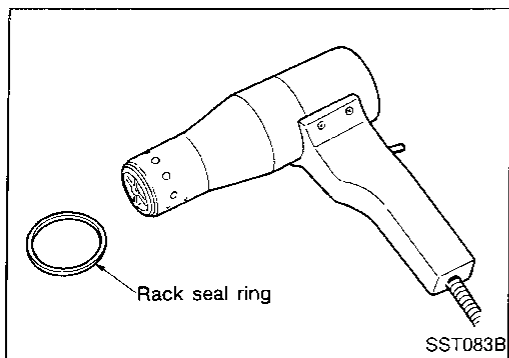

## Assembly

1. Using a heat gun, heat new teflon rack seal ring to approximately 40°C (104°F). Then place it onto rack.

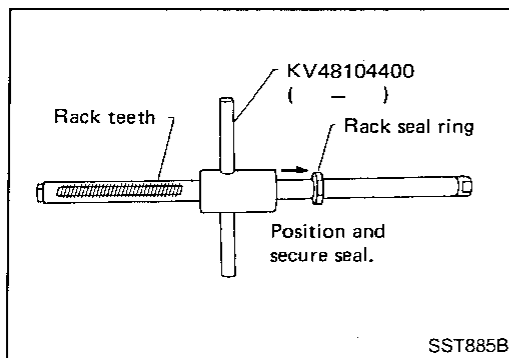

- Using Tool, compress rack seal ring securely on rack.
- Always insert the tool from the rack gear side.**

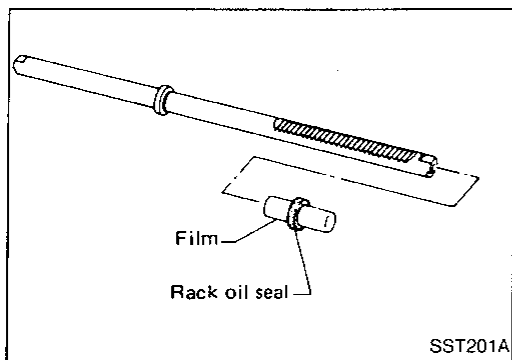

2. Insert rack oil seal.
- **Place plastic film into rack oil seal to prevent damage by rack teeth.**
  - **Always remove plastic film after rack oil seal is positioned properly.**
  - **Make sure lips of rack oil seal face each other.**

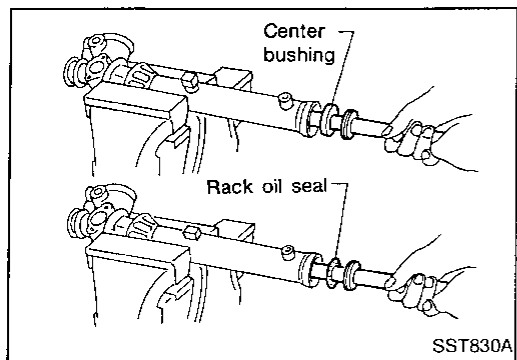

3. Install center bushing and rack oil seal with rack assembly.

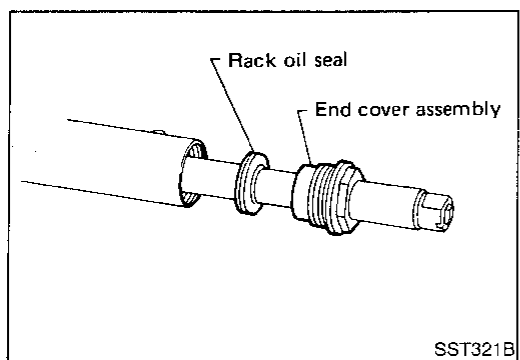

4. Insert rack oil seal and end cover assembly to rack then tighten end cover assembly.

GI

MA

EM

LC

EC

FE

AT

PD

FA

RA

BR

ST

RS

BT

HA

EL

IDX

# POWER STEERING GEAR AND LINKAGE

## Assembly (Cont'd)

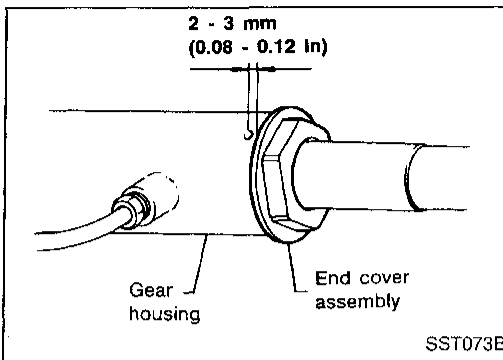

5. Fasten cylinder end cover assembly to gear housing by staking.

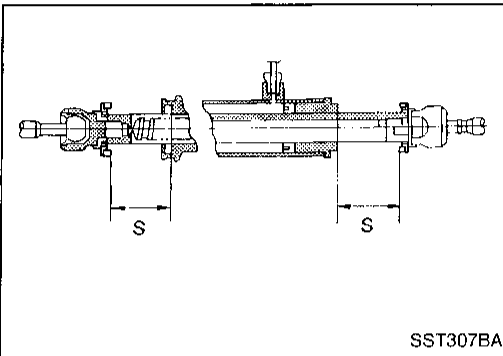

6. Set rack gear in neutral position.  
**Rack stroke "S":**  
Refer to SDS (ST-37).

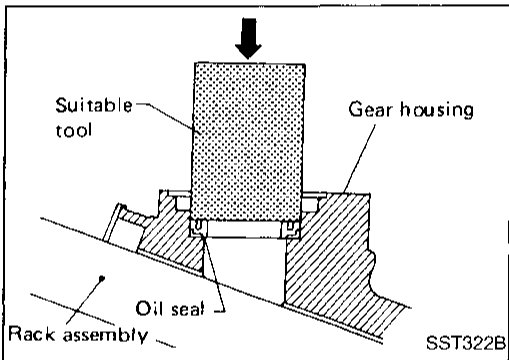

7. Coat seal lip of new pinion oil seal with multi-purpose grease.
  - Install it into pinion housing of gear with a suitable tool.
  - Make sure lip of oil seal faces up when installed.

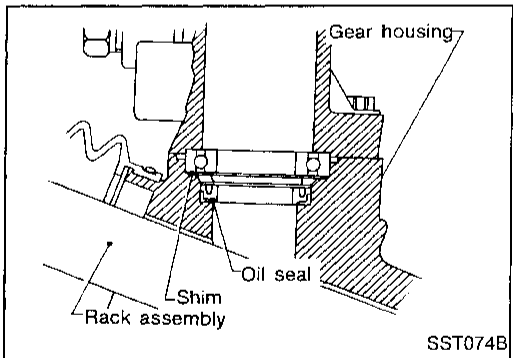

8. Install pinion bearing adjusting shim(s).
  - Whenever pinion assembly, gear housing and rear housing are disassembled, replace shim(s) with new ones. Always use the same number of shim(s) when replacing.

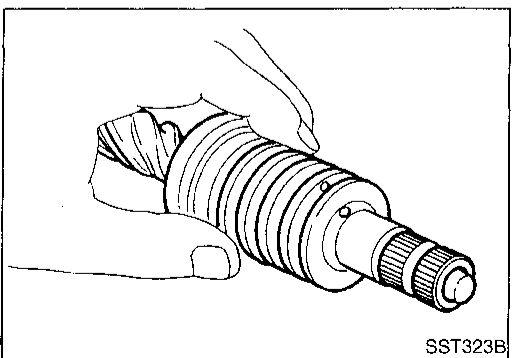

9. Install pinion seal ring on pinion gear assembly.
  - Using a heat gun, heat pinion seal ring to approximately 40°C (104°F) before installing it onto pinion gear assembly.
  - Make sure pinion seal ring is properly settled in valve groove.

# POWER STEERING GEAR AND LINKAGE

## Assembly (Cont'd)

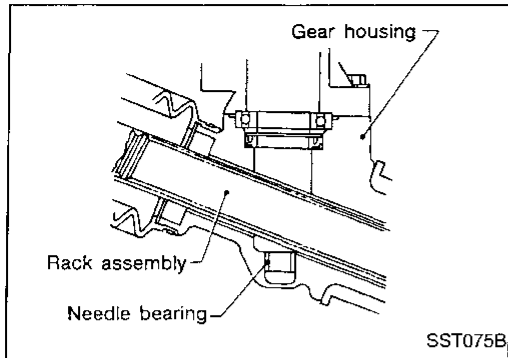

10. Apply a coat of multi-purpose grease to needle bearing roller and oil seal lip.

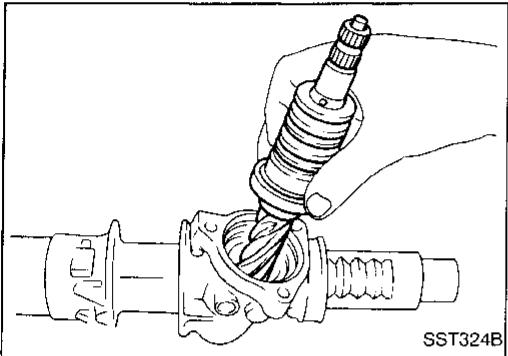

11. Install pinion assembly to pinion housing. Be careful not to damage pinion oil seal.

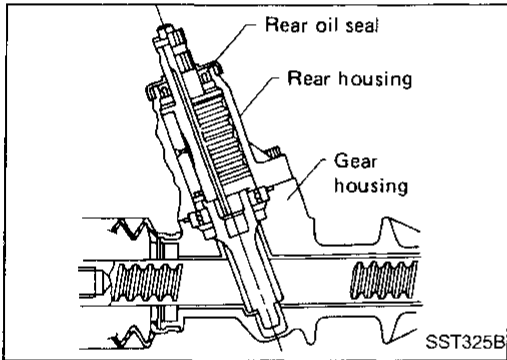

12. Apply a coat of multi-purpose grease to rear oil seal lip before installing rear housing.

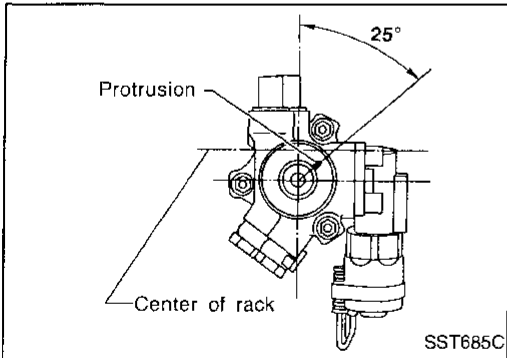

13. Ensure that the rack is centered. Install rear cover cap so that protrusion of rear housing cover is positioned as shown in figure.

Be careful not to damage worm ring and oil seal.

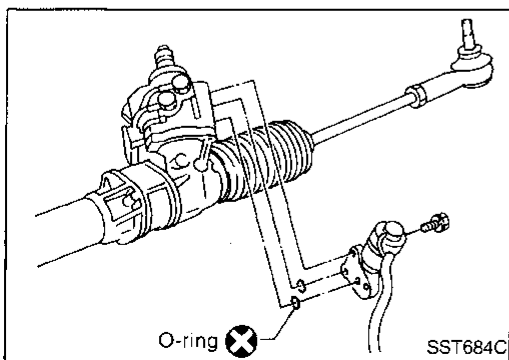

14. Install solenoid valve.

GI

MA

EM

LC

EC

FE

AT

PD

FA

RA

BR

ST

RS

BT

HA

EL

IDX

# POWER STEERING GEAR AND LINKAGE

## Assembly (Cont'd)

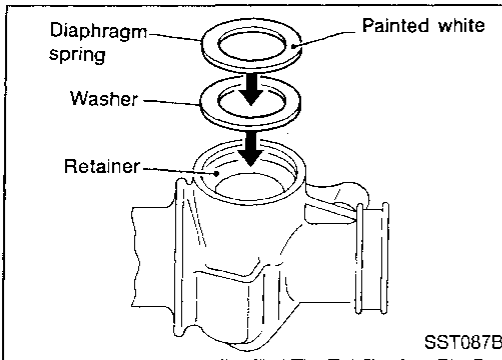

15. Install diaphragm spring at retainer.
  - Always install retainer, spring washer and diaphragm spring in that order.
  - Make sure convex end (painted white) of diaphragm spring faces outward when installing.
16. Install retainer spring and adjusting screw temporarily.

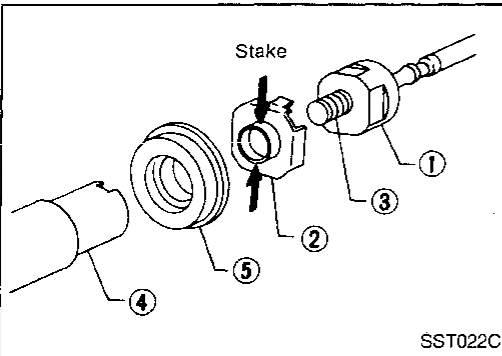

**CAUTION:**  
Ensure steering gear spacer is installed with rubber side facing rack.

- Attach lock plate ② to side rod inner socket ①.
- Insert steering gear spacer ⑤ to rack ④.
- Apply locking sealant to inner socket threads ③.
- Screw inner socket into rack ④ and tighten to specified torque.
- Stake lock plate at two places.

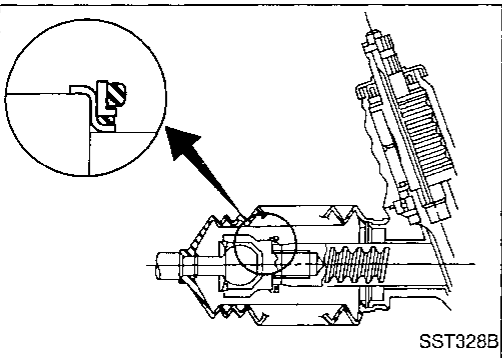

17. Install steering gear spacer ⑤ to lock plate ②.

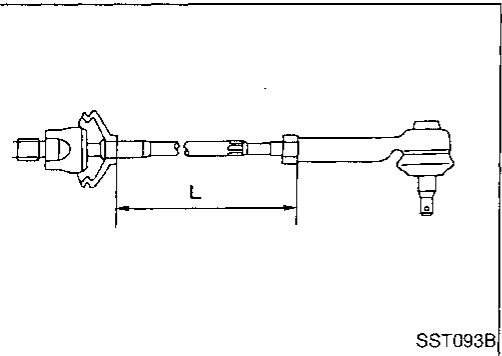

18. Tighten outer socket lock nut.  
**Tie-rod length "L":**  
Refer to SDS (ST-37).

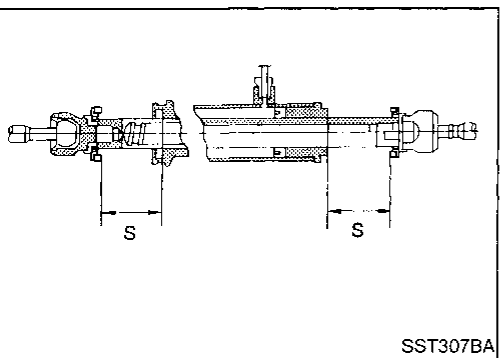

19. Measure rack stroke.  
**Rack stroke "S":**  
Refer to SDS (ST-37).

# POWER STEERING GEAR AND LINKAGE

## Assembly (Cont'd)

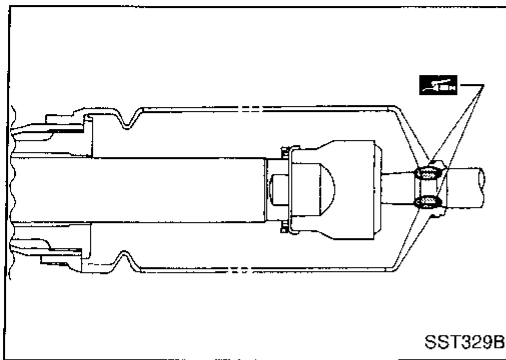

20. Before installing boot, coat the contact surfaces between boot and tie-rod with grease.

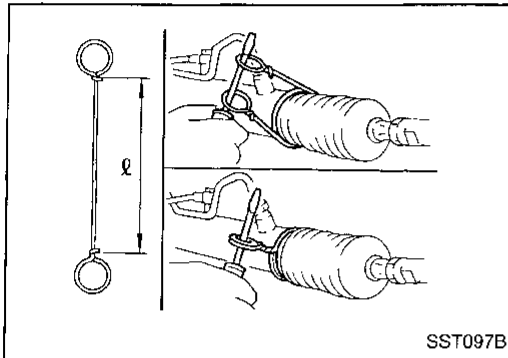

21. Install boot clamps.

- To install, wrap boot clamp around boot groove twice. To tighten clamp, place a screwdriver through both rings. Twist rings 4 to 4-1/2 turns while pulling with a force of approx. 98 N (10 kg, 22 lb).

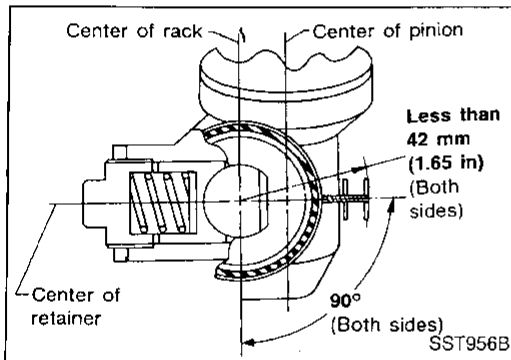

- Install boot clamp so that it is to the rear of the vehicle when gear housing is attached to the body. (This will prevent interference with other parts.)

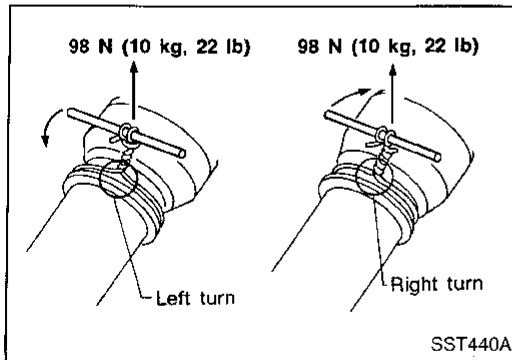

- Twist boot clamp in the direction shown in figure at left.

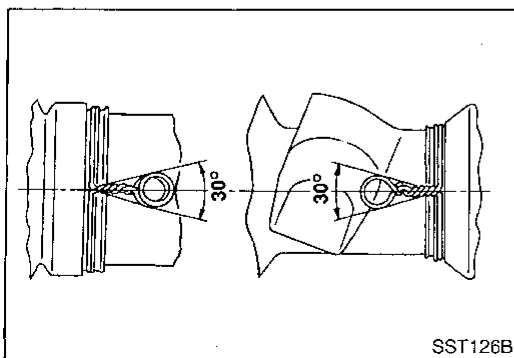

- After twisting boot clamp, bend twisted and diagonally so it does not contact boot.

GI

MA

EM

LC

EC

FE

AT

PD

FA

RA

BR

ST

RS

BT

HA

EL

IDX

# POWER STEERING GEAR AND LINKAGE

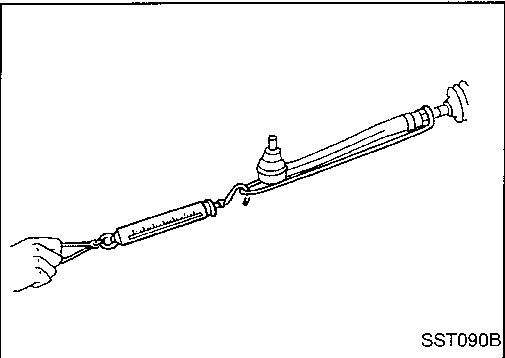
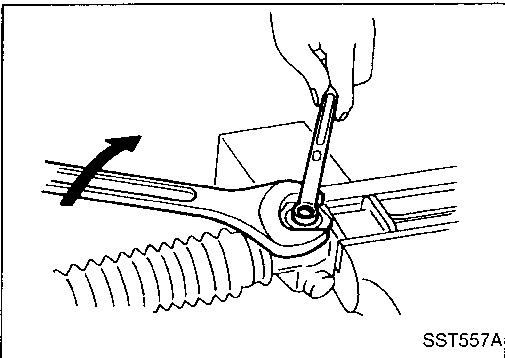
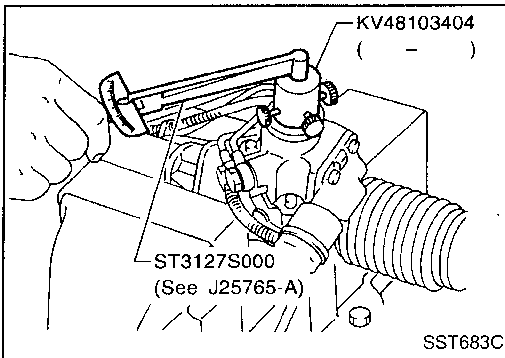
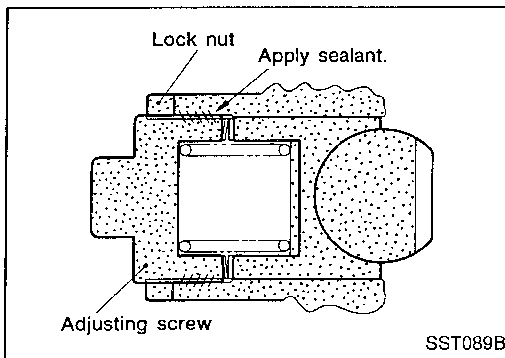

## Adjustment

Adjust pinion rotating torque as follows:

1. Set gears to Neutral without fluid in the gear.
2. Coat the adjusting screw with locking sealant and screw it in.
3. Lightly tighten lock nut.
4. Tighten adjusting screw to a torque of 4.9 to 5.9 N·m (50 to 60 kg-cm, 43 to 52 in-lb).
5. Loosen adjusting screw, then retighten it to 0.05 to 0.20 N·m (0.5 to 2 kg-cm, 0.43 to 1.74 in-lb).
6. Move rack over its entire stroke several times.
7. Measure pinion rotating torque within the range of 180° from neutral position.  
Stop the gear at the point of maximum torque.
8. Loosen adjusting screw, then retighten it to 4.9 N·m (50 kg-cm, 43 in-lb).
9. Loosen adjusting screw by 50° to 110°.
10. Prevent adjusting screw from turning, and tighten lock nut to specified torque.
11. Check steering gear for rack sliding frictional force.  
**Around neutral point of rack stroke**  
**±5.5 mm (±0.217 in):**  
**122.6 - 166.7 N (12.5 - 17 kg, 27.6 - 37.5 lb)**  
**Except for neutral point:**  
**122.6 - 186.3 N (12.5 - 19 kg, 27.6 - 41.9 lb)**
  - If sliding frictional force is out of specification, repeat the adjustment procedure, starting from No. 4.
  - After the readjustment, if sliding force is still out of specification, steering gear is damaged.



## POWER STEERING GEAR AND LINKAGE

### Adjustment (Cont'd)

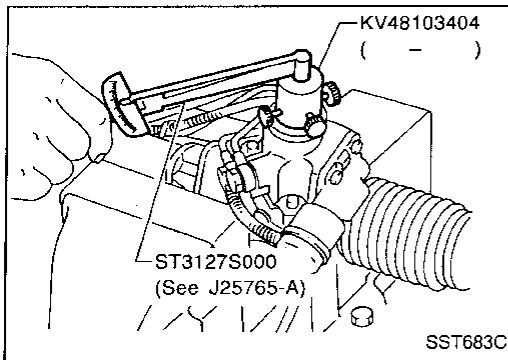

12. Measure pinion rotating torque within the range of  $\pm 100^\circ$  from the neutral point.

#### Average rotating torque

$[(\text{Max. measured value} + \text{Min. measured value}) \times 0.5]:$

0.8 - 1.3 N·m (8 - 13 kg-cm, 6.9 - 11.3 in-lb)

#### Maximum torque increment:

Less than 0.4 N·m (4 kg-cm, 3.5 in-lb)

#### Except for above mentioned measuring range:

##### Maximum rotating torque

1.9 N·m (19 kg-cm, 16 in-lb)

##### Maximum torque increment

Less than 0.6 N·m (6 kg-cm, 5.2 in-lb)

- If pinion rotating torque is not within specification, readjust it.
- After the readjustment, if pinion rotating torque is still out of specification, steering gear is damaged.

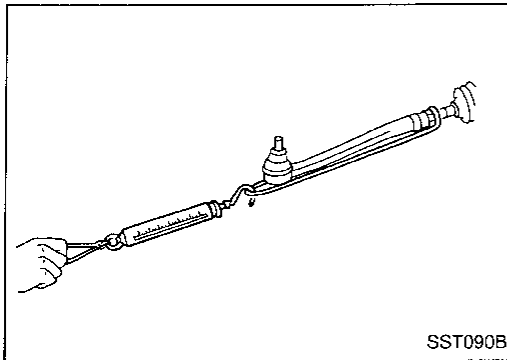

13. Check rack sliding force on vehicle as follows:

- Install steering gear onto vehicle, but do not connect tie-rod to knuckle arm.
- Connect all piping and fill with steering fluid.
- Start engine and bleed air completely.
- Disconnect steering column lower joint from the gear.
- Keep engine at idle and make sure steering fluid has reached normal operating temperature.
- Pull tie-rod slowly to move it from neutral position to  $\pm 11.5$  mm ( $\pm 0.453$  in) at speed of 3.5 mm (0.138 in)/s. Check that rack sliding force is within specification.

#### Rack sliding force:

235 - 294 N (24 - 30 kg, 53 - 66 lb)

- Check sliding force outside above range.

#### Rack sliding force:

Not more than 294 N (30 kg, 66 lb)

- If rack sliding force is not within specification, readjust by repeating adjustment procedure from the beginning.
- If rack sliding force is still out of specification after readjustment, gear assembly needs to be replaced.

# POWER STEERING OIL PUMP

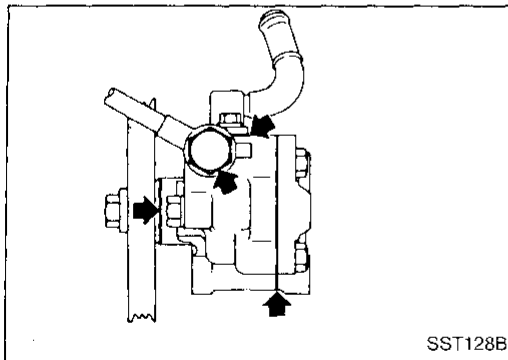
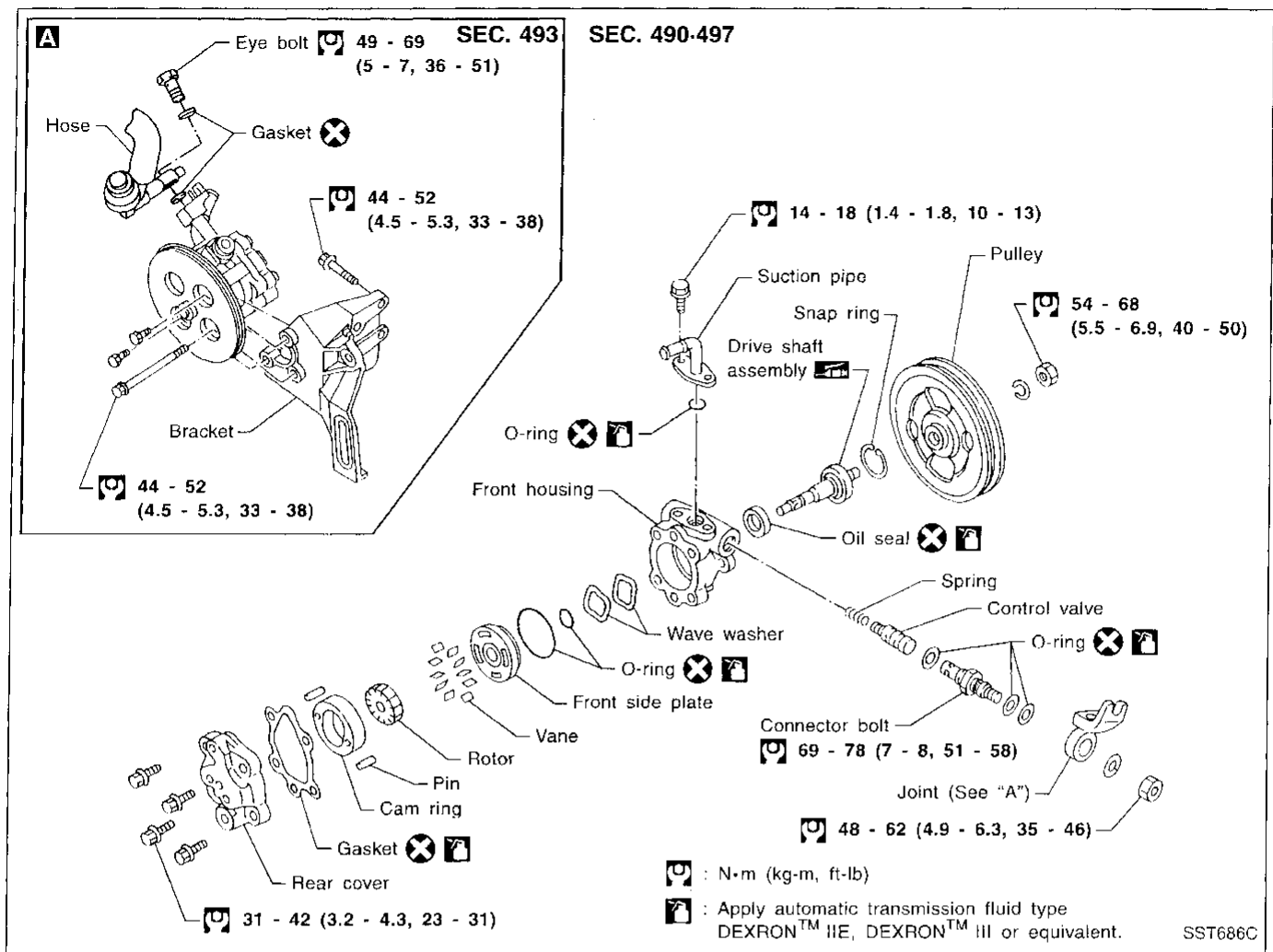

## Pre-disassembly Inspection

Disassemble the power steering oil pump only if the following items are found.

- Oil leak from any point shown in the figure.
- Deformed or damaged pulley.
- Poor performance

## Disassembly

### CAUTION:

- Parts which can be disassembled are strictly limited. Never disassemble parts other than those specified.
- Disassemble in as clean a place as possible.
- Clean your hands before disassembly.
- Do not use rags; use nylon cloths or paper towels.
- Follow the procedures and cautions in the Service Manual.
- When disassembling and reassembling, do not let foreign matter enter or contact the parts.

# POWER STEERING OIL PUMP

## Disassembly (Cont'd)

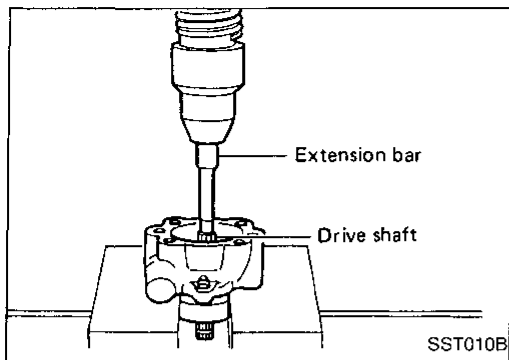

- Remove snap ring, then draw drive shaft out.  
**Be careful not to drop drive shaft.**

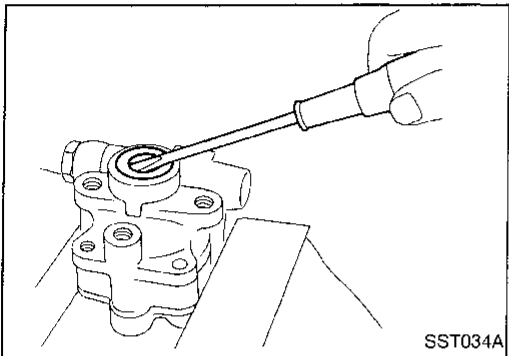

- Remove oil seal.  
**Be careful not to damage front housing.**

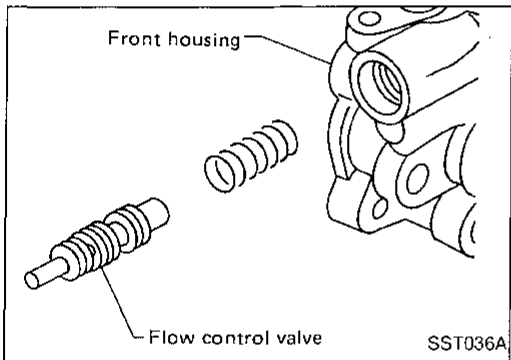

- Remove connector and flow control valve with spring.  
**Be careful not to drop flow control valve.**

## Inspection

- If pulley is cracked or deformed, replace it.
- If an oil leak is found around pulley shaft oil seal, replace the seal.
- If serration on pulley or pulley shaft is deformed or worn, replace it.

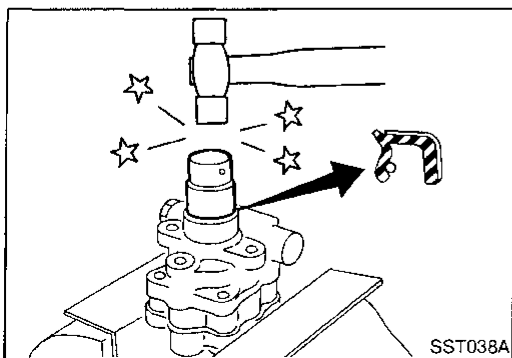

## Assembly

Assemble oil pump, noting the following instructions.

- Make sure O-rings and oil seal are properly installed.
- Always install new O-rings and oil seal.
- Be careful of oil seal direction.
- Cam ring, rotor and vanes must be replaced as a set if necessary.
- Coat each part with ATF when assembling.

GI

MA

EM

LC

EC

FE

AT

PD

FA

RA

BR

ST

RS

BT

HA

EL

IDX

# POWER STEERING OIL PUMP

## Assembly (Cont'd)

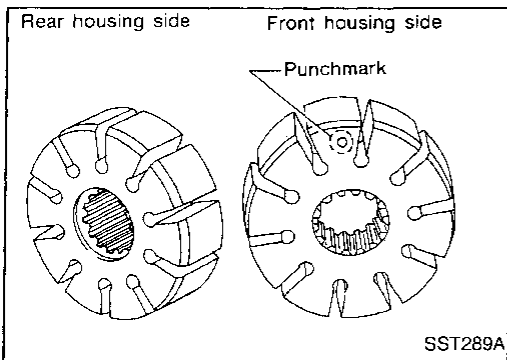

- Pay attention to rotor direction.

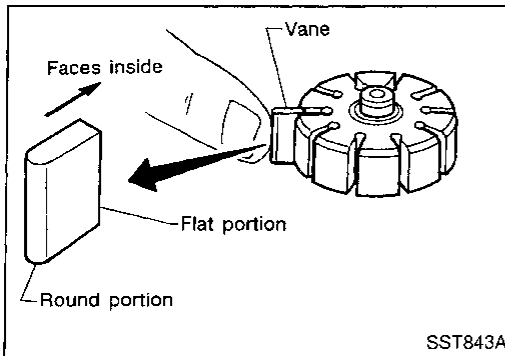

- When assembling vanes to rotor, rounded surfaces of vanes must face cam ring side.

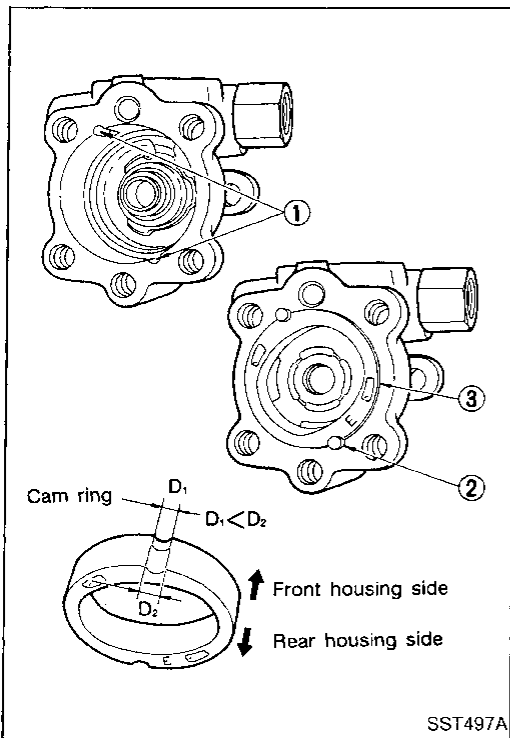

- Insert pin ② into pin groove ① of front housing and front side plate. Then install cam ring ③ as shown at left.

**Cam ring:**

$D_1$  is less than  $D_2$

# TWIN ORIFICE POWER STEERING SYSTEM

## Hydraulic Circuit

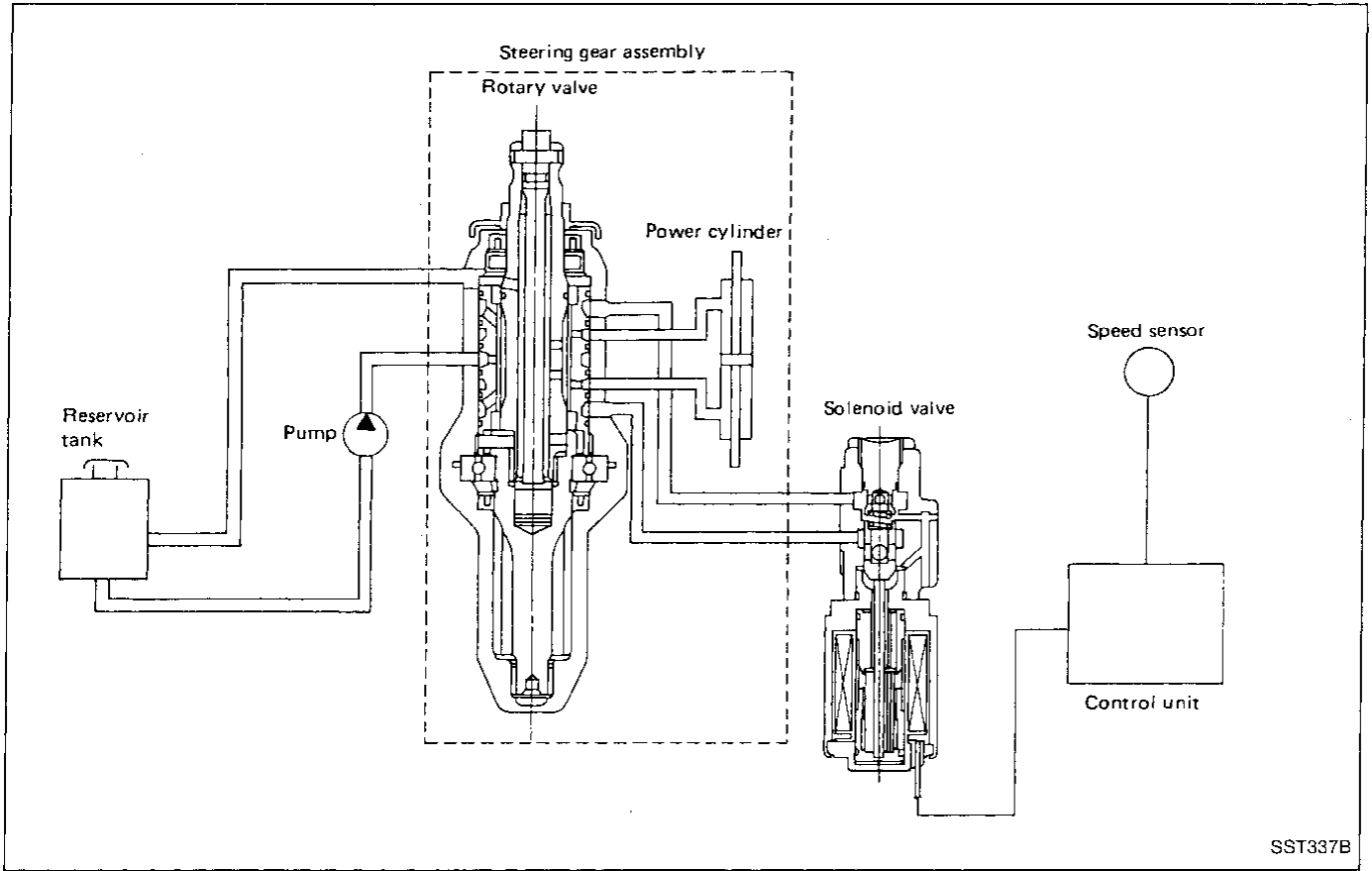

GI  
MA  
EM  
LC  
EC  
FE  
AT  
PD  
FA  
RA  
BR  
ST  
RS  
BT  
HA  
EL  
IDX

# TWIN ORIFICE POWER STEERING SYSTEM

## Wiring Diagram

ST-EPS-01

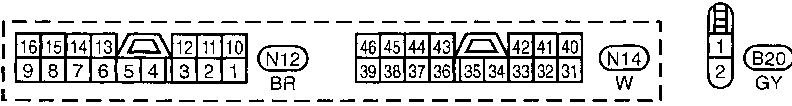
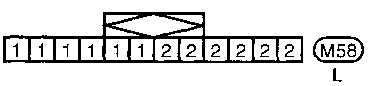
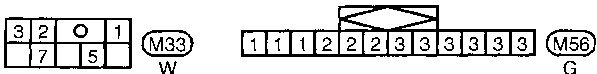
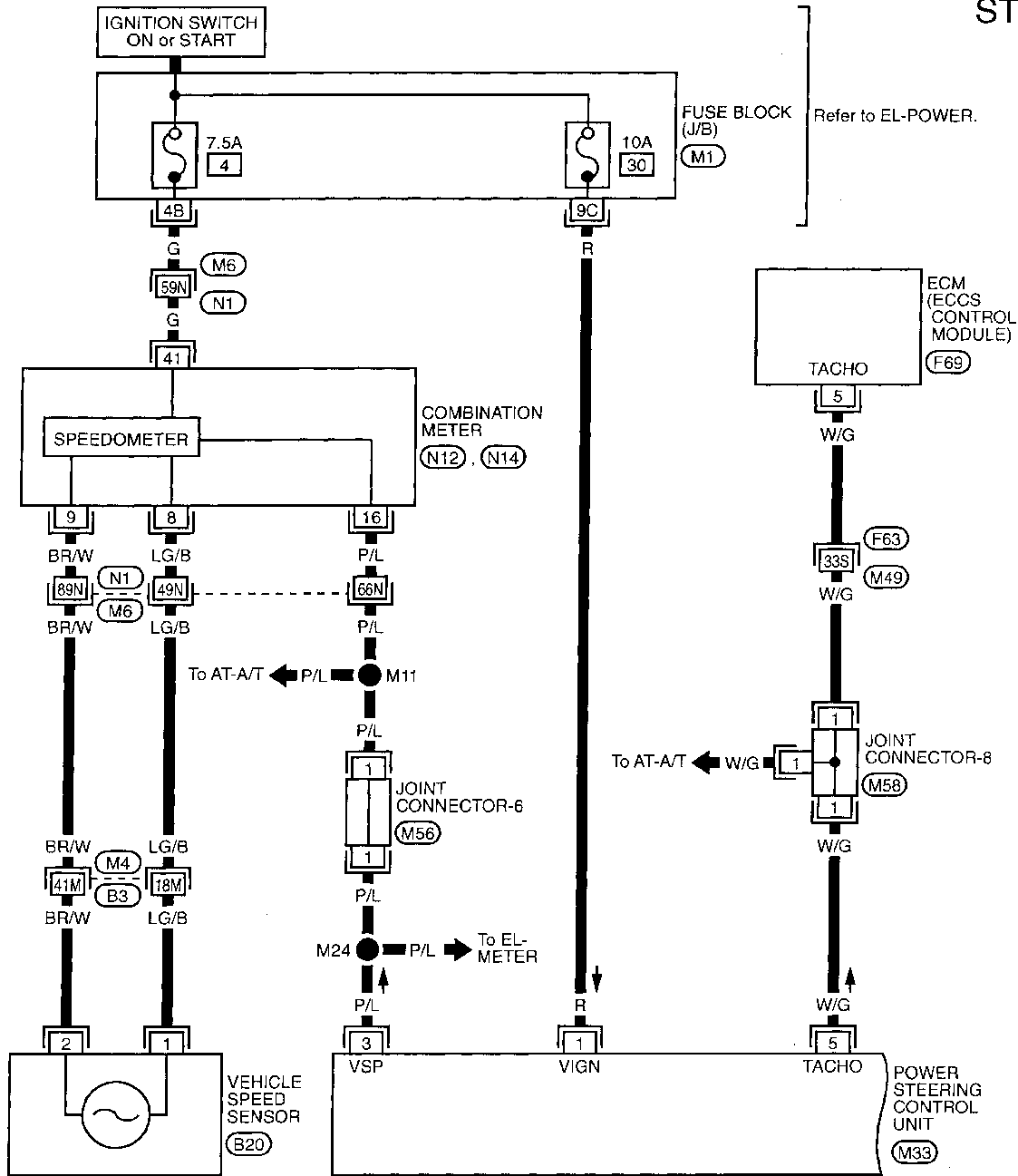

Refer to last page (Foldout page).  
 (M4) . (B3)  
 (M6) . (N1)  
 (M49) . (F63)  
 (M1)  
 (F69)

# TWIN ORIFICE POWER STEERING SYSTEM

## Wiring Diagram (Cont'd)

ST-EPS-02

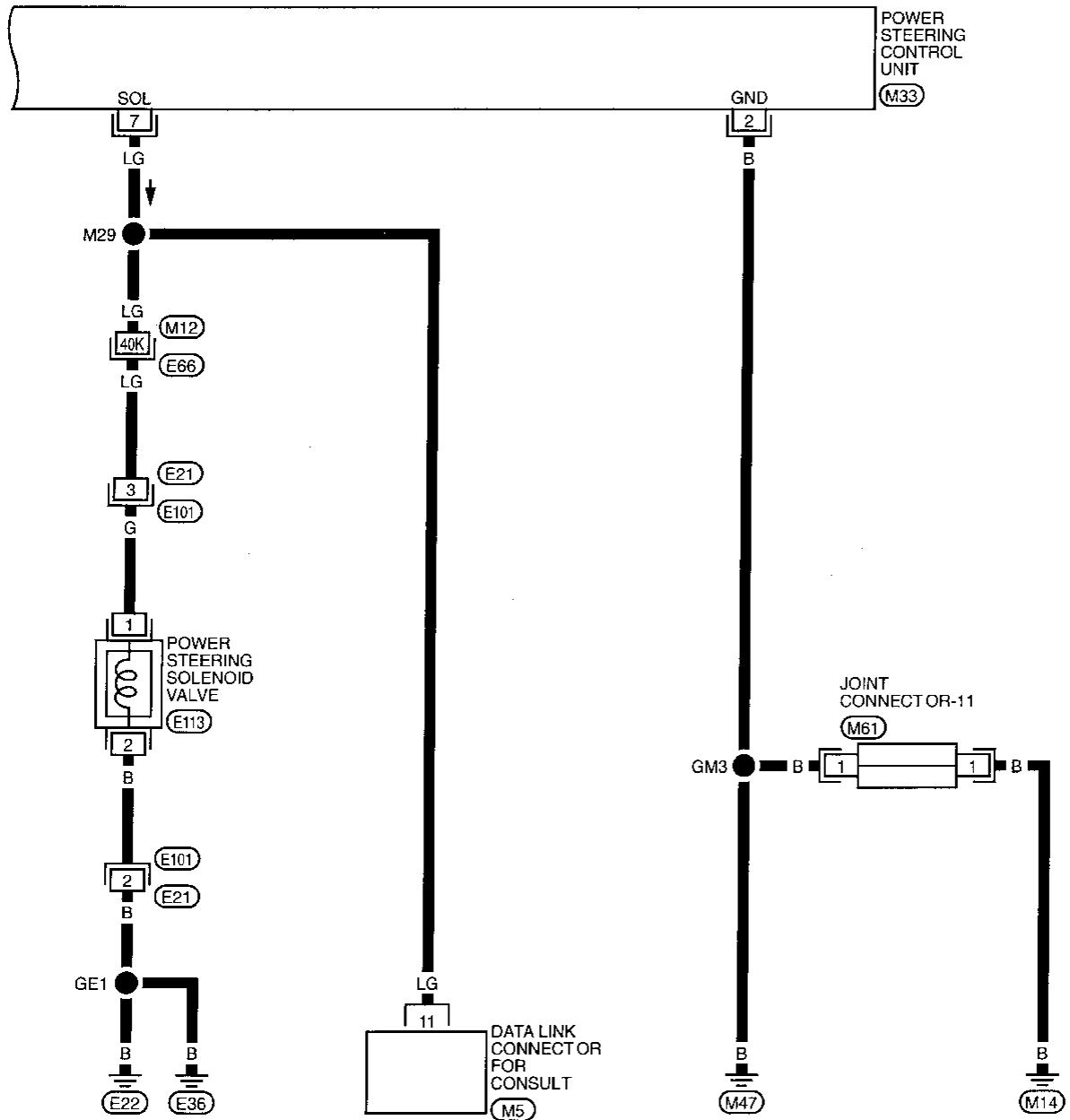

GI  
 MA  
 EM  
 LC  
 EC  
 FE  
 AT  
 PD  
 FA  
 RA  
 BR  
**ST**  
 RS  
 BT  
 HA  
 EL  
 DX

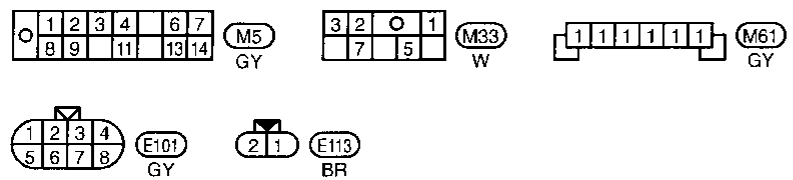

Refer to last page (Foldout page).  
 (E66), (M12)

## Precautions

### BEFORE DIAGNOSING THE POWER STEERING SYSTEM, ENSURE THAT:

#### Vehicle stopped

- Power steering components (gears, oil pump, pipes, etc.) are free from leakage, and that oil level is correct.
- Tires are inflated to specified pressure and are of specified size, and that steering wheel is a genuine Nissan part.
- Suspension utilizes the original design, and is free of modifications which increase vehicle weight.
- Wheel alignment is adjusted properly.

#### Vehicle in operation

- Understand the trouble symptoms.
- Engine is operating properly.

### PRELIMINARY KNOWLEDGE HELPFUL IN CONDUCTING DIAGNOSES

The power steering system is a twin orifice type, which uses a vehicle-speed sensing, electronic control design. Solenoid valve sensitivity is controlled in response to vehicle speed to achieve optimum steering effort.

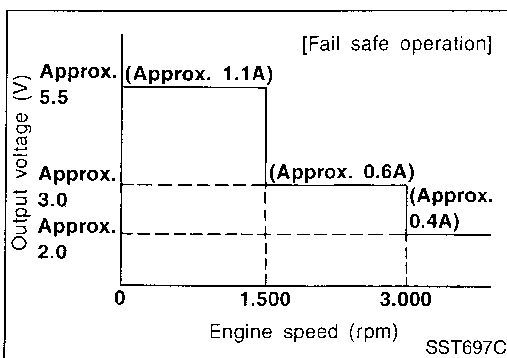
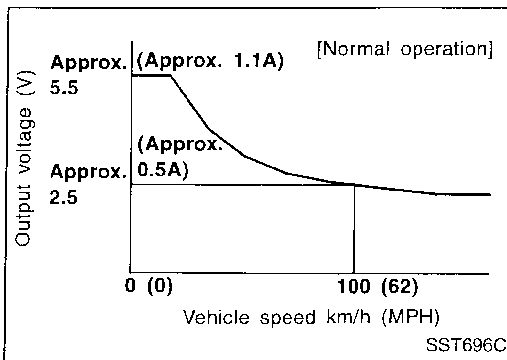

### FAIL-SAFE FUNCTION

The fail-safe function operates to regulate solenoid valve operation in response to engine speed, thereby maintaining the required steering force.

#### Fail-safe input conditions

Fail-safe input conditions	Release conditions
No vehicle speed signal is entered for at least 10 seconds while driving at an engine speed of greater than 1,500 rpm.	<ul style="list-style-type: none"> <li>A vehicle speed signal of greater than 1.4 km/h (0.9 MPH) is entered.</li> <li>Ignition key is turned from "OFF" to "ON".</li> </ul>
A vehicle speed signal of greater than 30 km/h (20 MPH) abruptly drops below 2 km/h (1 MPH).	

#### NOTE:

When the engine is revved up to 1,500 rpm or more for at least 10 seconds with the vehicle at standstill, the fail-safe function operates; however, this is not a matter of concern.

The fail-safe function can be released by driving the vehicle of a speed of greater than 1.4 km/h (0.9 MPH) or by turning the ignition key to "OFF".



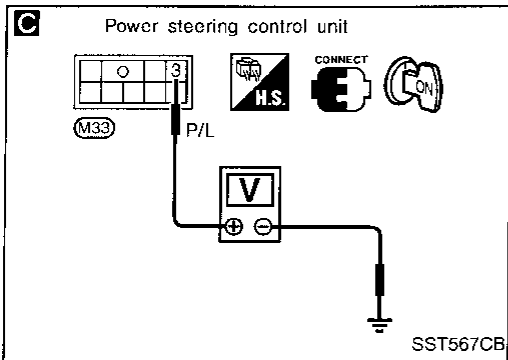
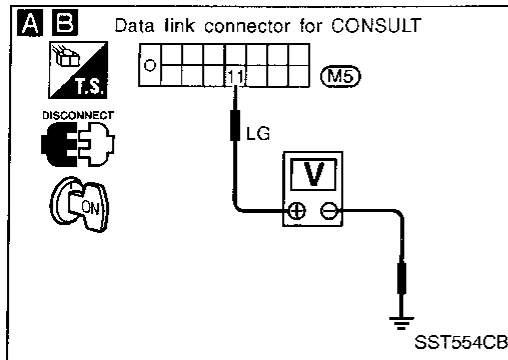

## Diagnostic Procedure

### SYMPTOM:

- Heavy steering operation during stationary turns
- Light steering operation during high-speed driving

Raise rear wheels off ground and start engine.

**A**

**CHECK SOLENOID VALVE VOLTAGE.**  
Measure voltage between solenoid valve terminal ① of data link connector for CONSULT and ground while driving vehicle from 0 to 100 km/h (0 to 62 MPH).

**Voltage:**  
 0 km/h (0 MPH):  
 4.4 - 6.6V ... OK  
 100 km/h (62 MPH):  
 2.5V ... OK  
 Constant voltage ... NG

OK → A

**B**

**CHECK ENGINE REVOLUTION VOLTAGE.**  
Measure voltage between solenoid valve terminal ② of data link connector for CONSULT and ground with engine at idle speed, approx. 1,600 rpm, and approx. 3,100 rpm respectively.

**Voltage:**  
**Idling:**  
 4.4 - 6.6V ... OK  
 1,600 rpm (approx.):  
 3.0V ... OK  
 3,100 rpm (approx.):  
 2.0V ... OK  
 No voltage variations ... NG

NG → B

**CHECK VEHICLE SPEED SENSOR INPUT SIGNAL.**  
Check speedometer for proper operation.  
YES ... OK  
NO ... NG

NG → Malfunctioning vehicle speed sensor or speedometer

**C**

Check if vehicle speed signal is present at power steering control unit. While driving at very slow speeds, measure voltage between control unit harness terminal ③ and ground.  
**0V (Min.) and 5V (Max.) are alternately repeated**  
 ... OK  
 No voltage is present ... NG

NG → Improper connection between speedometer and power steering control unit

OK → Malfunctioning power steering control unit

GI  
MA  
EM  
LC  
EC  
FE  
AT  
PD  
FA  
RA  
BR  
ST  
RS  
BT  
HA  
EL  
IDX

# TWIN ORIFICE POWER STEERING SYSTEM — Trouble Diagnoses

## Diagnostic Procedure (Cont'd)

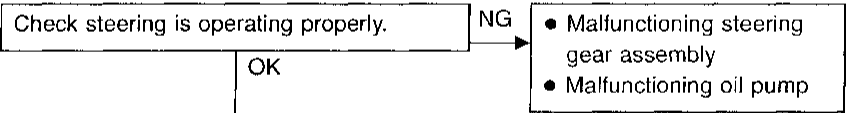
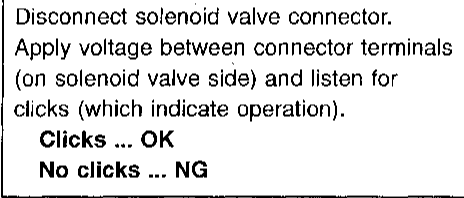
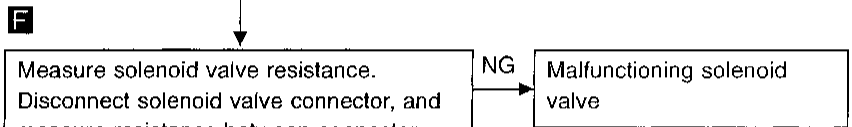
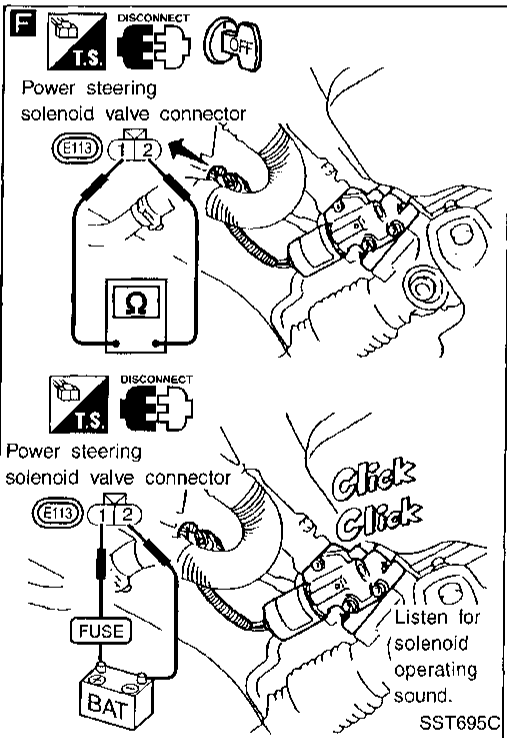
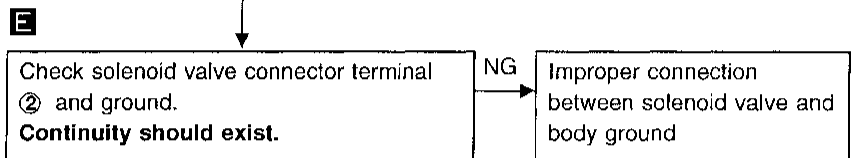
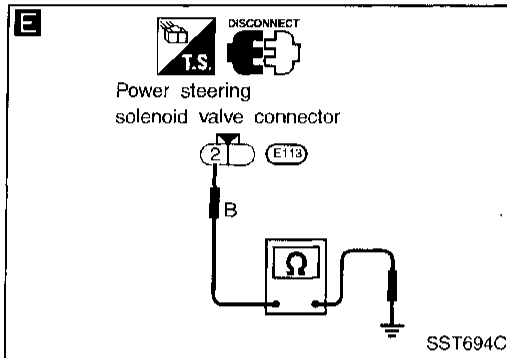
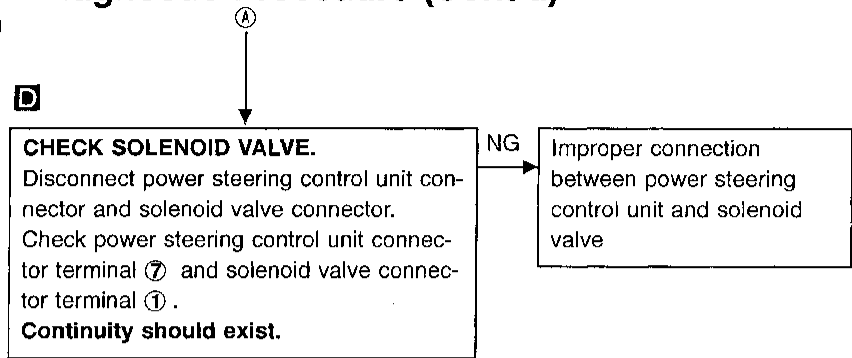
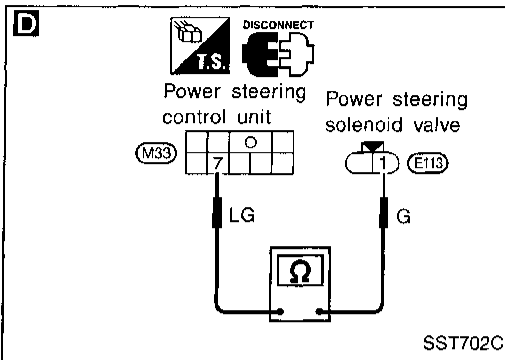

INSPECTION END

# TWIN ORIFICE POWER STEERING SYSTEM — Trouble Diagnoses

## Diagnostic Procedure (Cont'd)

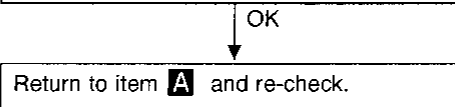
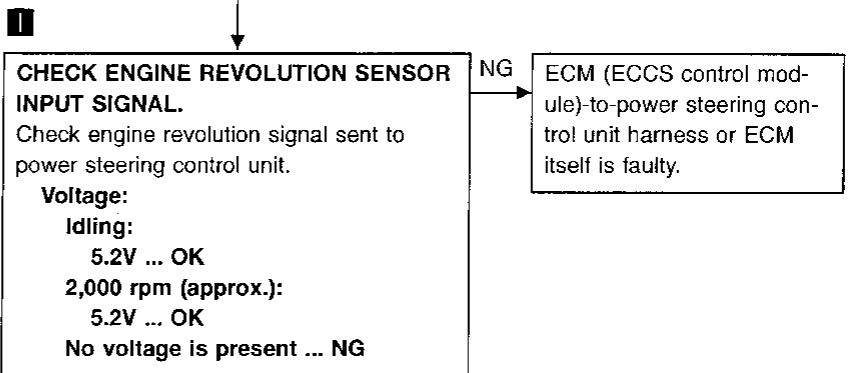
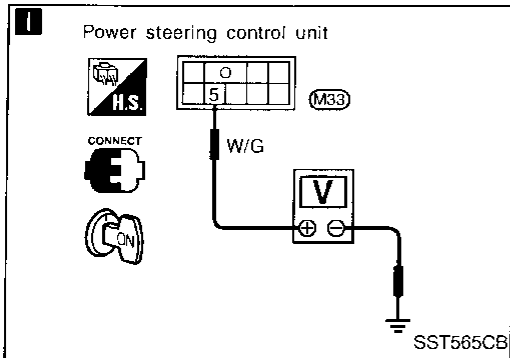
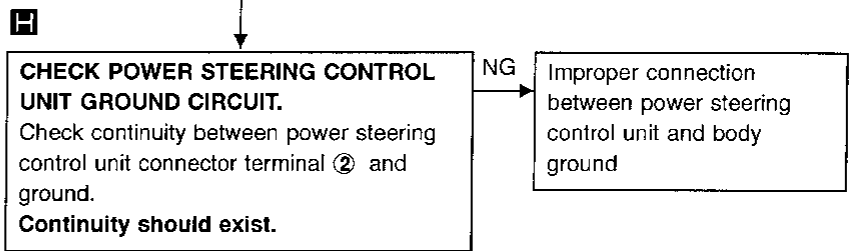
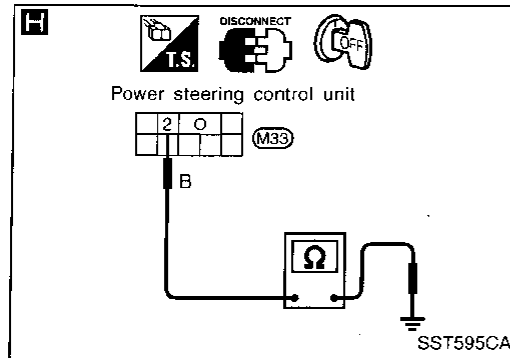
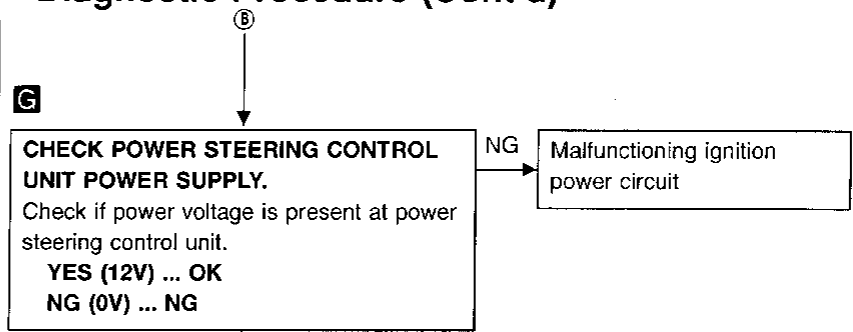
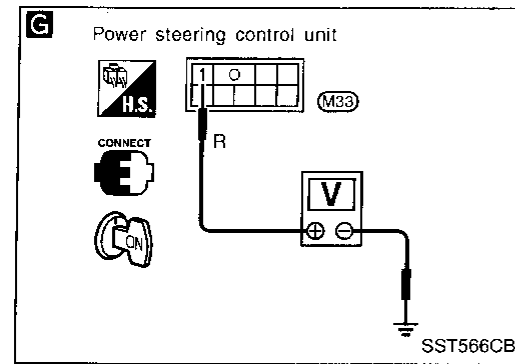

GI  
MA  
EM  
LC  
EC  
FE  
AT  
PD  
FA  
RA  
BR  
ST  
RS  
BT  
HA  
EL  
DX

## Control Unit Inspection Table

The standard values (voltage), measured with an analog tester in contact with the control unit terminal, are shown below:

Terminal No.	Application	Standard value
1	Power	Approx. 12V
2	Ground	0V
3	Vehicle speed sensor input	0V (min.) and 5V (max.) are alternately repeated when vehicle is driven at very slow speeds.
5	Engine revolution signal input	Engine operating at idle or 2,000 rpm (approx.): 5.2V
7	Power steering solenoid valve output	0 km/h (0 MPH): 4.4 - 6.6V 100 km/h (62 MPH): 2.5V Fail-safe 0 - 1,500 rpm: 4.4 - 6.6V 1,500 - 3,000 rpm: 3.0V 3,000 rpm or more: 2.0V



1	○	2	3
4	5	6	7

SST995B

# SERVICE DATA AND SPECIFICATIONS (SDS)

## General Specifications

Steering model	Power steering
Steering gear type	PR26AE
Steering overall gear ratio	18.5
Turn of steering wheel (Lock to lock)	3.26
Steering column type	Collapsible with automatic drive positioner

## Inspection and Adjustment

### STEERING WHEEL

Steering wheel axial play mm (in)	0 (0)
Steering wheel play mm (in)	0 - 35 (0 - 1.38)

### STEERING COLUMN

Steering column length "L <sub>1</sub> " mm (in)	633 - 668 (24.92 - 26.30)
Steering column lower shaft length "L <sub>2</sub> " mm (in)	334.5 (13.17)

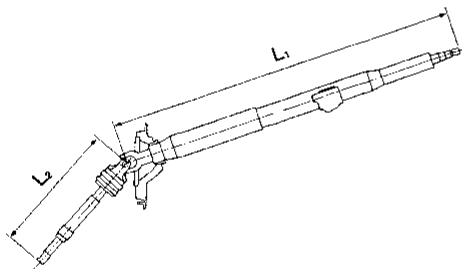

SST315B

### STEERING GEAR AND LINKAGE

Item	Steering gear type	PR26SE
Tie-rod outer ball joint		
Swinging force (at cotter pin hole) N (kg, lb)		4.9 - 46.1 (0.5 - 4.7, 1.1 - 10.4)
Rotating torque N-m (kg-cm, in-lb)		0.29 - 2.94 (3.0 - 30.0, 2.6 - 26.0)
Axial end play mm (in)		0 (0)
Tie-rod inner ball joint		
Swinging force* N (kg, lb)		7.8 - 65.7 (0.8 - 6.7, 1.8 - 14.8)
Rotating torque N-m (kg-cm, in-lb)		1.0 - 7.8 (10 - 80, 8.7 - 69)
Axial end play mm (in)		0 (0)
Tie-rod standard length "L" mm (in)		154.2 (6.07) or less

\*: Measuring point [ℓ: 120 mm (4.72 in)]

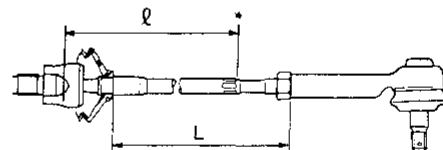

SST488C

Rack stroke "S"	mm (in)	67 (2.64)
-----------------	---------	-----------

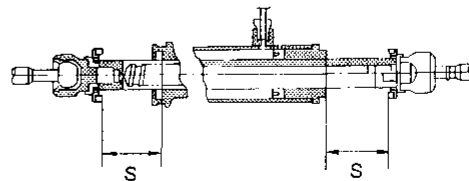

SST307BA

# SERVICE DATA AND SPECIFICATIONS (SDS)

## Inspection and Adjustment (Cont'd)

### POWER STEERING

Rack sliding force	N (kg, lb)	
Under normal operating oil pressure		
Range within $\pm 11.5$ mm ( $\pm 0.453$ in) from the neutral position		235 - 294 (24 - 30, 53 - 66)
Except above range		Not more than 294 (30, 66)
Retainer adjustment		
Adjusting screw		
Initial tightening torque	N-m (kg-cm, in-lb)	4.9 - 5.9 (50 - 60, 43 - 52)
Retightening torque after loosening		0.20 (2.0, 1.74)
Tightening torque after gear has settled		4.9 (50, 43)
Returning angle	degree	50° - 110°
Pinion gear preload without gear oil	N-m (kg-cm, in-lb)	
Within 100° from the neutral position		
Average rotating torque		0.8 - 1.3 (8 - 13, 6.9 - 11.3)
Maximum torque increment		0.4 (4, 3.5)
Except above range		
Maximum rotating torque		1.9 (19, 16)
Maximum torque increment		0.6 (6, 5.2)
Steering wheel turning force (Measured at one full turn from the neutral position)	N (kg, lb)	39 (4, 9) or less
Fluid capacity (Approximate)	ℓ (US qt, Imp qt)	1.3 (1-3/8, 1-1/8)
Oil pump maximum pressure	kPa (kg/cm <sup>2</sup> , psi)	8,140 - 8,728 (83 - 89, 1,180 - 1,266)