

BRAKE SYSTEM

SECTION **BR**

GI
MA
EM
LG

CONTENTS

PRECAUTIONS AND PREPARATION3	Disassembly.....20	EC
Supplemental Restraint System (SRS) "AIR BAG" and "SEAT BELT PRE-TENSIONER".....3	Inspection - Caliper.....20	
Precautions for Brake System.....3	Inspection - Rotor.....20	FE
Commercial Service Tools.....4	Assembly.....21	
NOISE, VIBRATION AND HARSHNESS (NVH)	Installation.....21	
TROUBLESHOOTING5	REAR DISC BRAKE22	AT
NVH Troubleshooting Chart.....5	Pad Replacement.....22	
ON-VEHICLE SERVICE6	Components.....23	PD
Checking Brake Fluid Level.....6	Removal.....23	
Checking Brake Line.....6	Disassembly.....24	FA
Changing Brake Fluid.....6	Inspection - Caliper.....24	
Brake Burnishing Procedure.....6	Inspection - Rotor.....24	FA
Bleeding Brake System.....7	Assembly.....25	
BRAKE HYDRAULIC LINE8	Installation.....25	RA
Removal.....8	REAR DISC BRAKE - Parking Drum Brake26	
Inspection.....8	Removal.....26	BR
Installation.....8	Inspection - Drum.....27	
CONTROL VALVE9	Inspection - Lining.....28	ST
Proportioning Valve.....9	Installation.....28	
BRAKE PEDAL AND BRACKET10	Shoe Clearance Adjustment.....29	
Removal and Installation.....10	Breaking in Drum and Lining.....29	RS
Inspection.....10	PARKING BRAKE CONTROL30	
Adjustment.....10	Removal and Installation.....30	
MASTER CYLINDER12	Inspection.....31	BT
Removal.....12	Adjustment.....31	
Disassembly.....12	TRACTION CONTROL SYSTEM - TCS32	
Inspection.....13	Purpose.....32	HA
Assembly.....13	System Components.....33	
Installation.....14	ABS (Anti-lock brake system) Operation.....34	EL
BRAKE BOOSTER15	ABS Hydraulic Circuit.....34	
On-vehicle Service.....15	TCS (Traction Control System) Operation.....35	
Removal.....15	Throttle Control + Engine Control TCS System Configuration (Tandem Throttle System).....35	IDX
Inspection.....15	Secondary Throttle Fully-closed Position Self-learning Control.....36	
Installation.....15	Removal and Installation.....37	
VACUUM HOSE17	TROUBLE DIAGNOSES41	
Removal and Installation.....17	How to Perform Trouble Diagnoses for Quick and Accurate Repair.....41	
Inspection.....17	Symptom Chart.....45	
FRONT DISC BRAKE18	Preliminary Check (Check brake fluid level in reservoir tank and brake line for leakage.).....48	
Pad Replacement.....18		
Components.....19		
Removal.....19		

CONTENTS (Cont'd)

Component Parts and Harness Connector		ACTUATOR/THROTTLE MOTOR: Throttle motor	
Location	49	circuit)	104
Schematic	50	Diagnostic Procedure 18 (THROTTLE MOTOR	
Wiring Diagram - TCS -	51	RLY [SHORT] (-a)/THROTTLE MOTOR RLY	
Self-diagnosis for ABS/TCS Control Unit	59	[OPEN] (-b): Throttle motor relay circuit for open	
CONSULT-II for ABS/TCS Control Unit.....	62	circuit and short circuit)	105
CONSULT-II Inspection Procedure for ABS/TCS		Diagnostic Procedure 19 (TH P/S PWR SUPPLY:	
Control Unit.....	63	Power supply circuit for sensor)	108
Self-diagnosis for TAC Module.....	70	Diagnostic Procedure 20 (THRTL/V RETURN	
CONSULT-II for TAC Module.....	72	SPR: Secondary throttle return spring)	108
CONSULT-II Inspection Procedure for TAC		Diagnostic Procedure 21 (ENGINE START SIG:	
Module	73	Start signal circuit)	109
Ground Circuit Check	79	Diagnostic Procedure 22 (NEUTRAL POSI SW:	
TROUBLE DIAGNOSES FOR SELF-DIAGNOSTIC		Park/Neutral position (PNP) switch circuit)	110
ITEMS.....	80	TROUBLE DIAGNOSES FOR SYMPTOMS.....	112
Diagnostic Procedure 1 (Engine system).....	80	Diagnostic Procedure 23 (SLIP indicator does	
Diagnostic Procedure 2 (TCM COMM: TAC		not come on when ignition switch is turned on.).....	112
module communication).....	80	Diagnostic Procedure 24 (TCS OFF indicator	
Diagnostic Procedure 3 (Engine speed signal).....	83	does not come on when ignition switch is turned	
Diagnostic Procedure 4 (LAN SIGNAL 1: LAN		on.).....	113
monitoring)	84	Diagnostic Procedure 25 (ABS warning lamp	
Diagnostic Procedure 5 (LAN SIGNAL 2: LAN		does not come on when ignition switch is turned	
communication start procedures incomplete).....	85	on.).....	114
Diagnostic Procedure 6 (LAN CIRCUIT 1/LAN		Diagnostic Procedure 26 (ABS warning lamp	
CIRCUIT 2: LAN communication system failure).....	86	stays on when ignition switch is turned on.)	116
Diagnostic Procedure 7 (Wheel sensor or rotor)	87	Diagnostic Procedure 27 (TCS OFF switch is	
Diagnostic Procedure 8 (ABS actuator solenoid		inoperative.)	119
valve)	89	Diagnostic Procedure 28	
Diagnostic Procedure 9 (Solenoid valve relay)	90	(ABS works frequently.)	120
Diagnostic Procedure 10 (Motor relay or motor).....	93	Diagnostic Procedure 29	
Diagnostic Procedure 11 (BATTERY VOLT: Low		(Unexpected pedal action).....	121
voltage)	96	Diagnostic Procedure 30	
Diagnostic Procedure 12 (Control unit).....	97	(Long stopping distance)	121
Diagnostic Procedure 13 (Power supply and		Diagnostic Procedure 31	
ground circuit for TAC module).....	98	(ABS does not work.)	122
Diagnostic Procedure 14 (THROTTLE POSI		Diagnostic Procedure 32	
SEN: Throttle position sensor signal input circuit) ..	100	(Pedal vibration and noise).....	122
Diagnostic Procedure 15 (THROTTLE POSI		Electrical Component Inspection	123
SEN2: Secondary throttle position sensor signal		TROUBLE DIAGNOSES FOR TCS	125
input circuit)	101	Electrical Component Inspection	125
Diagnostic Procedure 16 (THRTL POS/S-2 SIG:		SERVICE DATA AND SPECIFICATIONS (SDS)	128
Secondary throttle valve operating signal circuit		General Specifications.....	128
and throttle valve opening signal circuit).....	102	Inspection and Adjustment	128
Diagnostic Procedure 17 (THROTTLE			

When you read wiring diagrams:

- Read GI section, "HOW TO READ WIRING DIAGRAMS".
- See EL section, "POWER SUPPLY ROUTING" for power distribution circuit.

When you perform trouble diagnoses, read GI section, "HOW TO FOLLOW FLOW CHART IN TROUBLE DIAGNOSES".

Supplemental Restraint System (SRS) “AIR BAG” and “SEAT BELT PRE-TENSIONER”

The Supplemental Restraint System such as “AIR BAG” and “SEAT BELT PRE-TENSIONER” used along with a seat belt, helps to reduce the risk or severity of injury to the driver and front passenger for certain types of collision. The SRS system composition which is available to INFINITI Q45 is as follows:

- For a frontal collision
The Supplemental Restraint System consists of driver air bag module (located in the center of the steering wheel), front passenger air bag module (located on the instrument panel on passenger side), seat belt pre-tensioners, a diagnosis sensor unit, warning lamp, wiring harness and spiral cable.
- For a side collision
The Supplemental Restraint System consists of front side air bag module (located in the outer side of front seat), satellite sensor, diagnosis sensor unit (one of components of air bags for a frontal collision), wiring harness, warning lamp (one of components of air bags for a frontal collision).

Information necessary to service the system safely is included in the **RS section** of this Service Manual.

WARNING:

- To avoid rendering the SRS inoperative, which could increase the risk of personal injury or death in the event of a collision which would result in air bag inflation, all maintenance should be performed by an authorized INFINITI dealer.
- Improper maintenance, including incorrect removal and installation of the SRS, can lead to personal injury caused by intentional activation of the system. For removal of Spiral Cable and Air Bag Module, see the RS section.
- Do not use electrical test equipment on any circuit related to the SRS unless instructed to in this Service Manual. Spiral cable and wiring harnesses (except satellite sensor and side air bag module) covered with yellow insulation tape either just before the harness connectors or for the complete harness are related to the SRS.

GI
MA
EM
LC
EC
FE
AT
PD
FA
RA

BR

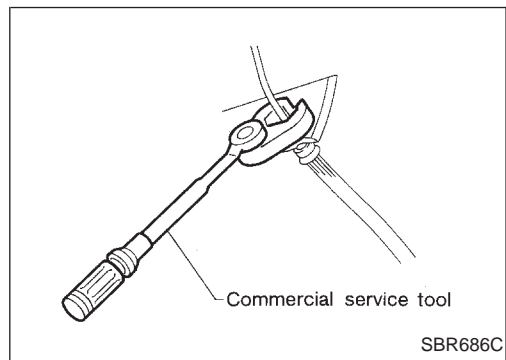

Precautions for Brake System

- Use brake fluid “DOT 3”.
- Never reuse drained brake fluid.
- Be careful not to splash brake fluid on painted areas; it may cause paint damage. If brake fluid is splashed on painted areas, wash it away with water immediately.
- To clean master cylinder parts, disc brake caliper parts or wheel cylinder parts, use clean brake fluid.
- Never use mineral oils such as gasoline or kerosene. They will ruin rubber parts of hydraulic system.
- Use flare nut wrench when removing and installing brake tubes.
- Always torque brake lines when installing.
- Burnish the brake contact surfaces after refinishing or replacing drums or rotors, after replacing pads or linings, or if a soft pedal occurs at very low mileage. Refer to “Brake Burnishing Procedure”, “ON-VEHICLE SERVICE”, BR-6.

WARNING:

- Clean brakes with a vacuum dust collector to minimize risk of health hazard from powder caused by friction.

ST
RS
BT
HA
EL
IDX

Commercial Service Tools

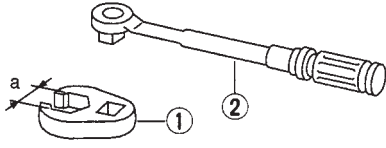
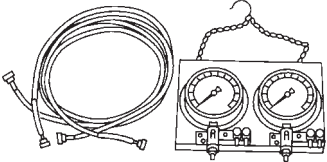
Tool name	Description
① Flare nut crowfoot ② Torque wrench	<div style="display: flex; justify-content: space-between;"> <div data-bbox="464 296 915 443">  <p>NT360</p> </div> <div data-bbox="1013 247 1446 275"> Removing and installing each brake piping </div> </div> <p style="text-align: right; margin-right: 100px;">a: 10 mm (0.39 in)</p>
Brake fluid pressure gauge	<div style="display: flex; justify-content: space-between;"> <div data-bbox="464 506 889 667">  <p>NT151</p> </div> <div data-bbox="1013 470 1325 497"> Measuring brake fluid pressure </div> </div>



NVH Troubleshooting Chart

Use the chart below to help you find the cause of the symptom. If necessary, repair or replace these parts.

Symptom	BRAKE	Possible cause and SUSPECTED PARTS			Reference page
		Noise			
		Shake	Shimmy, Judder		
		X		Linings or pads - damaged	BR-18, 22
		X		Linings or pads - uneven wear	BR-18, 22, 28
		X		Return spring damaged	BR-26
		X		Shims damaged	BR-19, 23
	X	X		Rotor or drum imbalance	—
	X			Rotor or drum damage	—
	X			Rotor or drum runout	BR-20, 25
	X			Rotor or drum deformation	—
	X			Rotor or drum deflection	—
	X			Rotor or drum rust	—
	X			Rotor thickness variation	BR-21, 25
	X			Drum out of round	—
		X	X	PROPELLER SHAFT	Refer to PD section.
			X	DIFFERENTIAL	Refer to PD section.
	X	X	X	AXLE AND SUSPENSION	Refer to FA and RA sections.
	X	X	X	TIRES	Refer to FA section.
	X	X	X	ROAD WHEEL	Refer to FA section.
		X	X	DRIVE SHAFT	Refer to RA section.
	X	X	X	STEERING	Refer to ST section.

X: Applicable

BR

RA

FA

PD

AT

FE

EC

LG

EM

MA

GI

ST

RS

BT

HA

EL

IDX

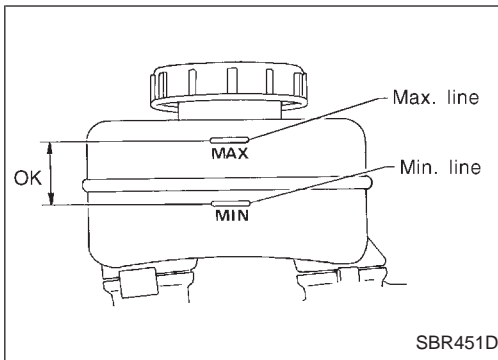

Checking Brake Fluid Level

- Check fluid level in reservoir tank. It should be between Max. and Min. lines on reservoir tank.
- If fluid level is extremely low, check brake system for leaks.
- When brake warning lamp comes on even when parking brake lever is released, check brake system for leaks.

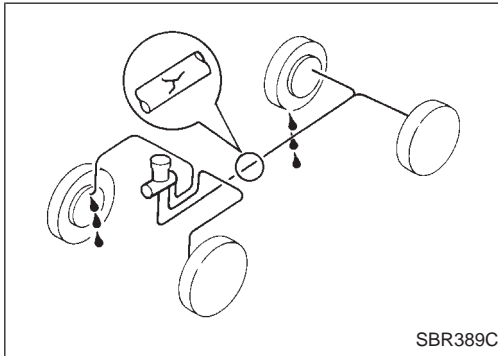

Checking Brake Line

CAUTION:

If leakage occurs around joints, retighten or, if necessary, replace damaged parts.

1. Check brake lines (tubes and hoses) for cracks, deterioration or other damage. Replace any damaged parts.
2. Check for oil leakage by fully depressing brake pedal while engine is running.

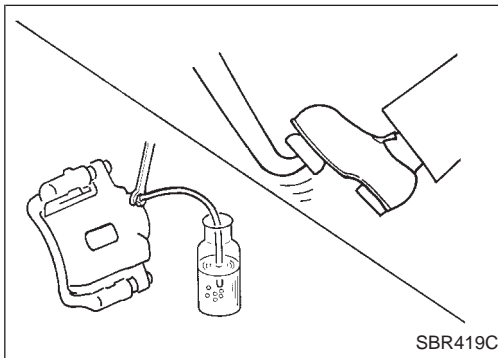

Changing Brake Fluid

CAUTION:

- Refill with new brake fluid "DOT 3".
- Always keep fluid level higher than minimum line on reservoir tank.
- Never reuse drained brake fluid.
- Be careful not to splash brake fluid on painted areas; it may cause paint damage. If brake fluid is splashed on painted areas, wash it away with water immediately.

1. Clean inside of reservoir tank, and refill with new brake fluid.
2. Connect a vinyl tube to each air bleeder valve.
3. Drain brake fluid from each air bleeder valve by depressing brake pedal.
4. Refill until brake fluid comes out of each air bleeder valve. Use same procedure as in bleeding hydraulic system to refill brake fluid. Refer to "Bleeding Brake System", BR-7.

Brake Burnishing Procedure

Burnish the brake contact surfaces according to the following procedure after refinishing or replacing drums or rotors, after replacing pads or linings, or if a soft pedal occurs at very low mileage.

CAUTION:

Only perform this procedure under safe road and traffic conditions. Use extreme caution.

1. Drive the vehicle on a straight smooth road at 50 km/h (31 MPH).

ON-VEHICLE SERVICE

Brake Burnishing Procedure (Cont'd)

2. Use medium brake pedal/foot effort to bring the vehicle to a complete stop from 50 km/h (31 MPH). Adjust brake pedal/foot pressure such that vehicle stopping time equals 3 to 5 seconds.
3. To cool the brake system, drive the vehicle at 50 km/h (31 MPH) for 1 minute without stopping.
4. Repeat steps 1 to 3 10 times or more to complete the burnishing procedure.

GI

MA

EM

LC

EC

FE

AT

PD

FA

RA

BR

ST

RS

BT

HA

EL

IDX

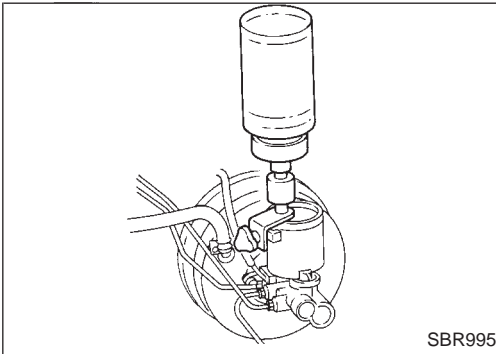

SBR995

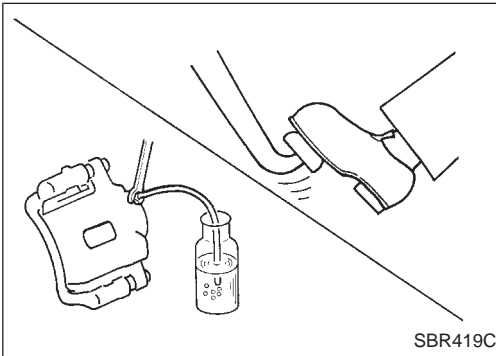

SBR419C

Bleeding Brake System

CAUTION:

- Carefully monitor brake fluid level at master cylinder during bleeding operation.
 - If master cylinder is suspected to have air inside, bleed air from master cylinder first. Refer to "Installation", "MASTER CYLINDER", BR-14.
 - Fill reservoir with new brake fluid "DOT 3". Make sure it is full at all times while bleeding air out of system.
 - Place a container under master cylinder to avoid spillage of brake fluid.
 - Turn ignition switch OFF and disconnect ABS actuator connector or battery cable.
- Bleed air in the following order:
Right rear brake → Left rear brake → Right front brake → Left front brake.
1. Connect a transparent vinyl tube to air bleeder valve.
 2. Fully depress brake pedal several times.
 3. With brake pedal depressed, open air bleeder valve to release air.
 4. Close air bleeder valve.
 5. Release brake pedal slowly.
 6. Repeat steps 2. through 5. until clear brake fluid comes out of air bleeder valve.
 7. Tighten air bleeder valve.

: 7 - 9 N·m (0.7 - 0.9 kg-m, 61 - 78 in-lb)

BRAKE HYDRAULIC LINE

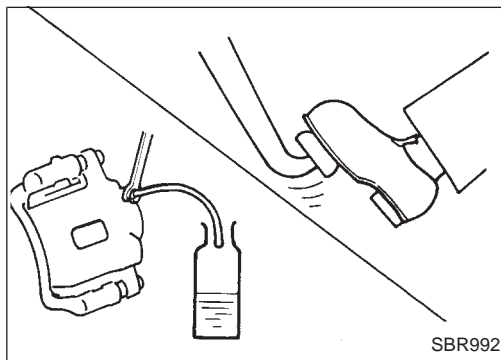
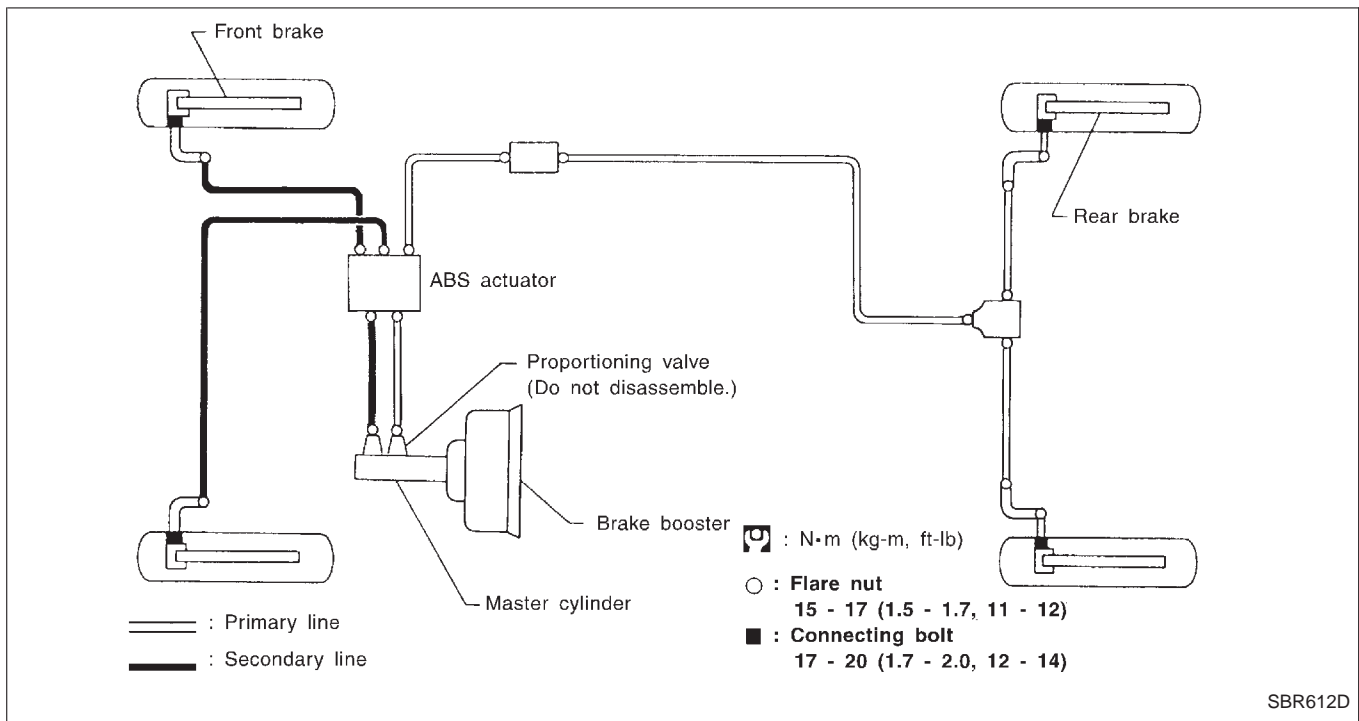

Removal

CAUTION:

- Be careful not to splash brake fluid on painted areas; it may cause paint damage. If brake fluid is splashed on painted areas, wash it away with water immediately.
- All hoses must be free from excessive bending, twisting and pulling.

1. Connect a vinyl tube to air bleeder valve.
2. Drain brake fluid from each air bleeder valve by depressing brake pedal.
3. Remove flare nut securing brake tube to hose, then withdraw lock spring.
4. Cover openings to prevent entrance of dirt whenever disconnecting hydraulic line.

Inspection

Check brake lines (tubes and hoses) for cracks, deterioration or other damage. Replace any damaged parts.

Installation

CAUTION:

- Refill with new brake fluid "DOT 3".
- Never reuse drained brake fluid.

1. Tighten all flare nuts and connecting bolts.

Flare nut:

○ : 15 - 17 N·m (1.5 - 1.7 kg-m, 11 - 12 ft-lb)

Connecting bolt:

○ : 17 - 20 N·m (1.7 - 2.0 kg-m, 12 - 14 ft-lb)

2. Refill until new brake fluid comes out of each air bleeder valve.
3. Bleed air. Refer to "Bleeding Brake System", BR-7.

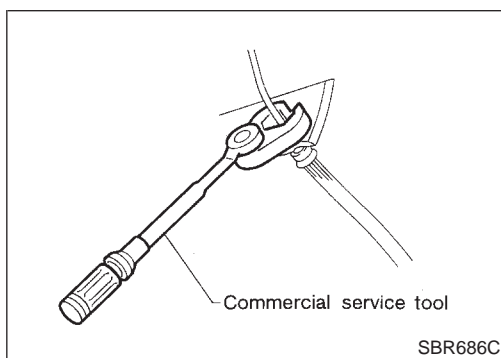

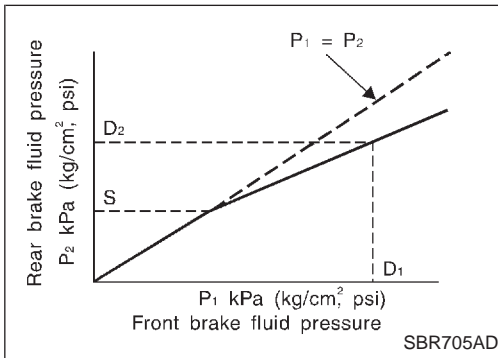
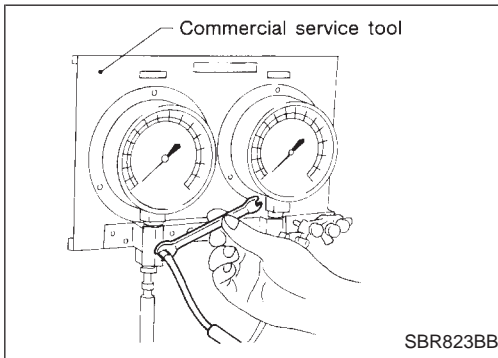
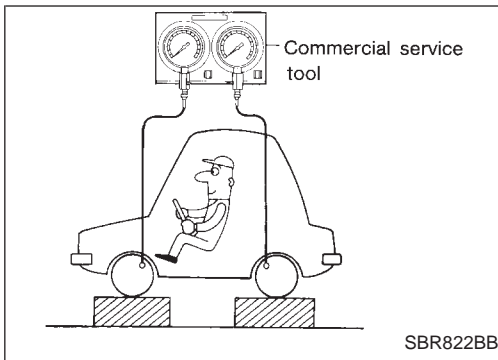

Proportioning Valve

INSPECTION

CAUTION:

- Carefully monitor brake fluid level at master cylinder.
- Use new brake fluid "DOT 3".
- Be careful not to splash brake fluid on painted areas; it may cause paint damage. If brake fluid is splashed on paint areas, wash it away with water immediately.
- Depress pedal slowly when raising front brake pressure.
- Check rear brake pressure 2 seconds after front brake pressure reaches specified value.
- Disconnect harness connectors from ABS actuator relay box before checking.

1. Connect tool to air bleeders of front and rear brakes on either LH or RH side.
2. Bleed air from the tool.
3. Check rear brake pressure by depressing brake pedal (increasing front brake pressure).

Unit: kPa (kg/cm², psi)

Applied pressure (Front brake)	D_1	7,355 (75, 1,067)
Output pressure (Rear brake)	D_2	5,100 - 5,492 (52 - 56, 739 - 796)

- If output pressure is out of specifications, replace master cylinder assembly (built-in type).
4. Bleed air after disconnecting the tool. Refer to "Bleeding Brake System", BR-7.

REMOVAL AND INSTALLATION (Built-in type)

Always replace together with master cylinder as an assembly.

- Refer to "MASTER CYLINDER", BR-12.

GI

MA

EM

LC

EC

FE

AT

PD

FA

RA

BR

ST

RS

BT

HA

EL

IDX

Removal and Installation

SEC. 465

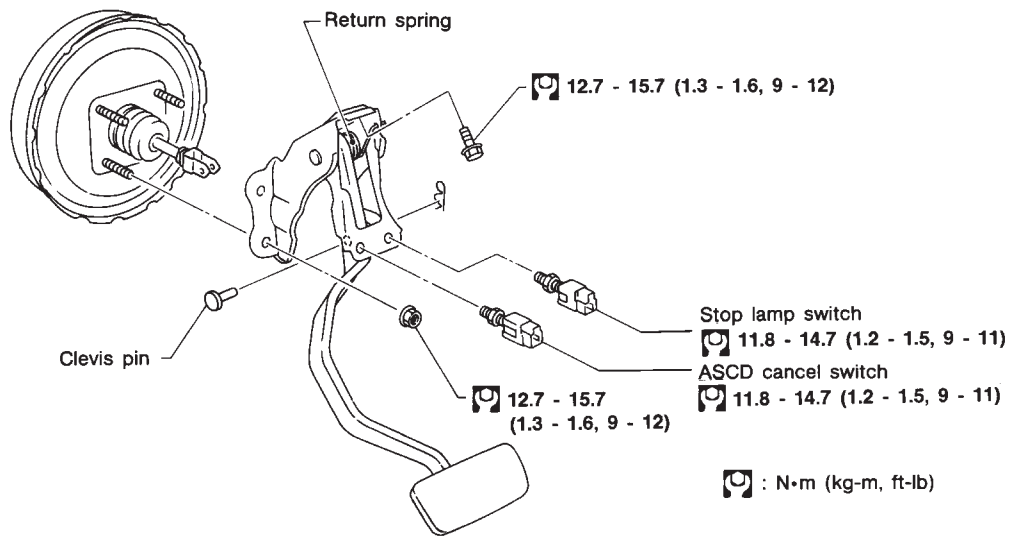

SBR037CC

Inspection

Check brake pedal for following items:

- Brake pedal bend
- Clevis pin deformation
- Crack of any welded portion
- Crack or deformation of clevis pin stopper

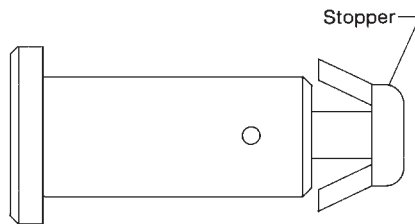

SBR997

Adjustment

Check brake pedal free height from metal panel.

- H:** Free height
Refer to SDS, BR-128.
- D:** Depressed height
Refer to SDS, BR-128.
Under force of 490 N (50 kg, 110 lb) with engine running
- C₁, C₂:** Clearance between pedal stopper and threaded end of stop lamp switch and ASCD cancel switch
0.3 - 1.0 mm (0.012 - 0.039 in)
- A:** Pedal free play
1.0 - 3.0 mm (0.039 - 0.118 in)

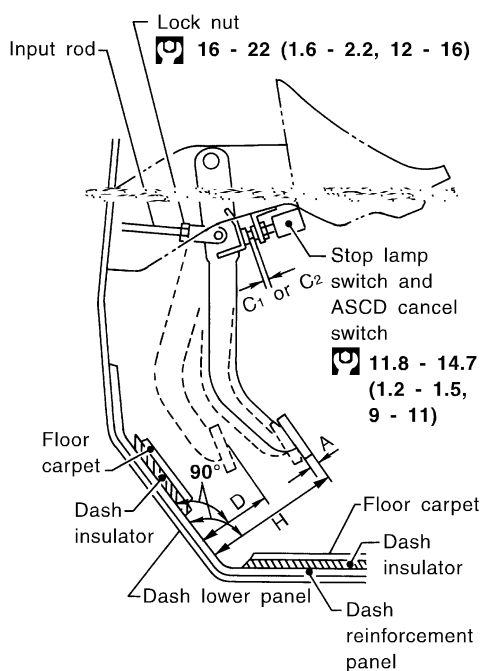

: N·m (kg-m, ft-lb)

SBR453DA

BRAKE PEDAL AND BRACKET

Adjustment (Cont'd)

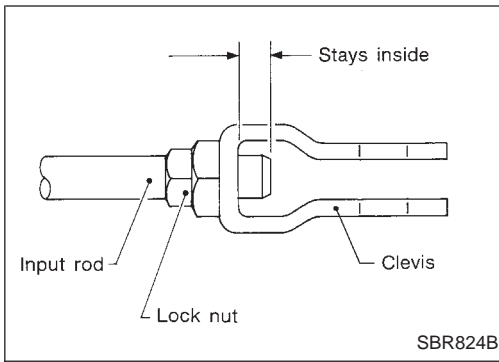

If necessary, adjust brake pedal free height.

1. Loosen lock nut and adjust pedal free height by turning brake booster input rod. Then tighten lock nut.

Make sure that tip of input rod stays inside of clevis.

GI

MA

EM

2. Loosen lock nut and adjust clearance "C₁" and "C₂" with stop lamp switch and ASCD cancel switch respectively. Then tighten lock nuts.

LC

3. Check pedal free play.

Make sure that stop lamps go off when pedal is released.

EC

4. Check brake pedal's depressed height while engine is running. If depressed height is below specifications, check brake system. If leaks, accumulation of air or any damage to components (master cylinder, etc.) are found, make necessary repairs.

FE

AT

PD

FA

RA

BR

ST

RS

BT

HA

EL

IDX

MASTER CYLINDER

SEC. 460

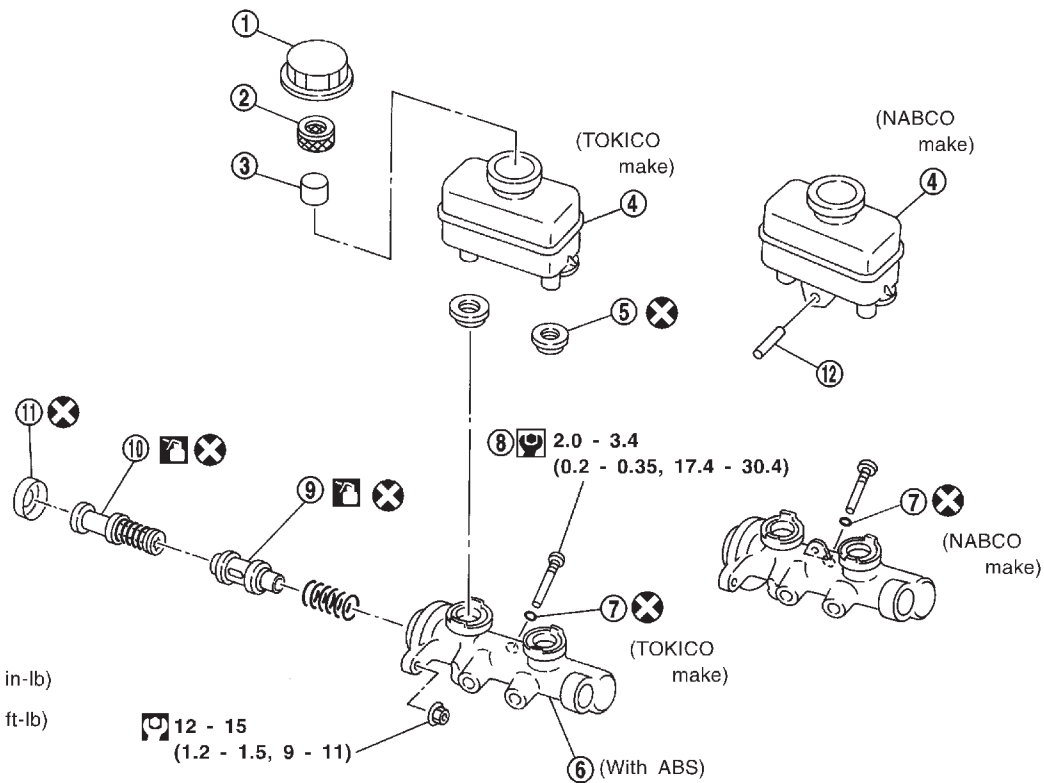

SBR362E

- | | | |
|------------------|------------------|-----------------------------|
| ① Reservoir cap | ⑤ Seal | ⑨ Secondary piston assembly |
| ② Oil filter | ⑥ Cylinder body | ⑩ Primary piston assembly |
| ③ Float | ⑦ O-ring | ⑪ Stopper cap |
| ④ Reservoir tank | ⑧ Piston stopper | ⑫ Spring pin |

Removal

CAUTION:

- Be careful not to splash brake fluid on painted areas; it may cause paint damage. If brake fluid is splashed on painted areas, wash it away with water immediately.
- In the case of brake fluid leakage from the master cylinder, disassemble the cylinder. Then check piston cups for deformation or scratches and replace necessary parts.

1. Connect a vinyl tube to air bleeder valve.
2. Drain brake fluid from each air bleeder valve, depressing brake pedal to empty fluid from master cylinder.
3. Remove brake pipe flare nuts.
4. Remove master cylinder mounting nuts.

Disassembly

1. Bend claws of stopper cap outward.

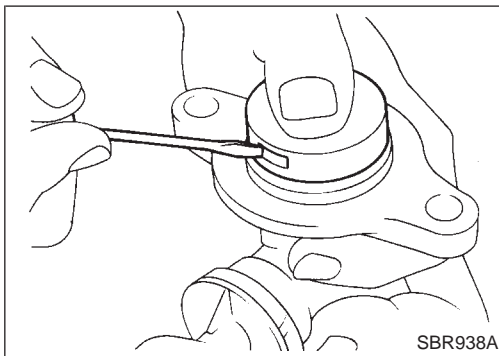

MASTER CYLINDER

Disassembly (Cont'd)

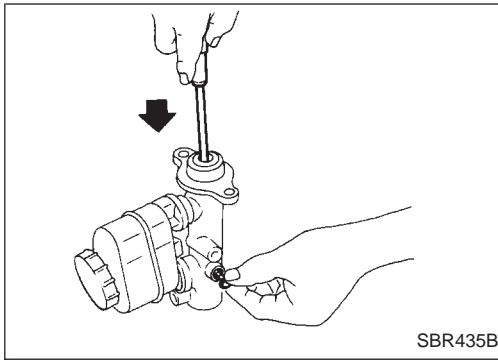

2. Remove valve stopper while piston is pushed into cylinder.

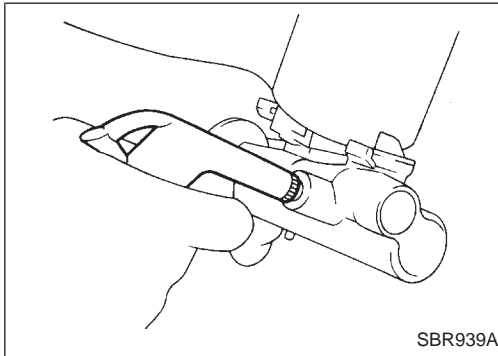

3. Remove piston assemblies.

If it is difficult to remove secondary piston assembly, gradually apply compressed air through fluid outlet.

— For TOKICO make —

4. Draw out reservoir tank.

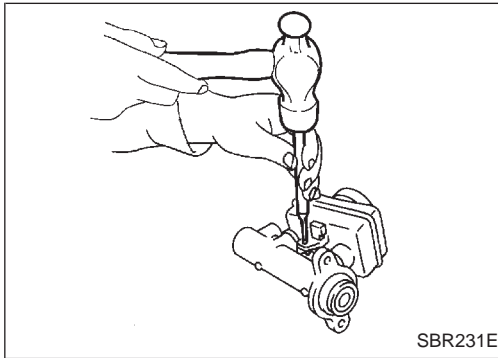

— For NABCO make —

4. Drive out spring pin from cylinder body.

5. Draw out reservoir tank and seals.

GI

MA

EM

LC

EC

FE

AT

PD

FA

RA

BR

ST

RS

BT

HA

EL

IDX

Inspection

Check master cylinder inner wall for pin holes or scratches. Replace if damaged.

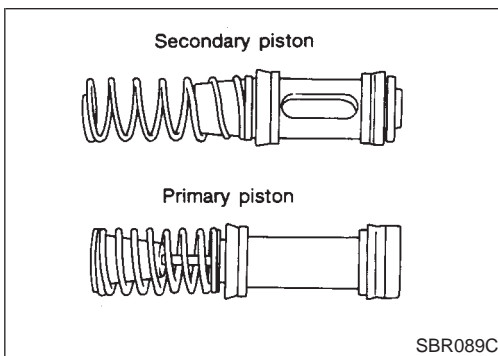

Assembly

1. Insert secondary piston assembly. Then insert primary piston assembly.

- Pay attention to direction of piston cups in figure at left. Also, insert pistons squarely to avoid scratches on cylinder bore.

- Pay attention to alignment of secondary piston slit with valve stopper mounting hole of cylinder body.

MASTER CYLINDER

Assembly (Cont'd)

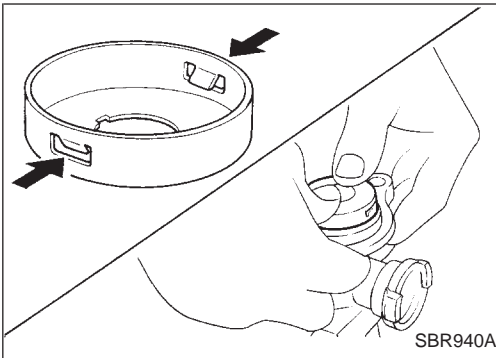

2. Install stopper cap.

Before installing stopper cap, ensure that claws are bent inward.

— For TOKICO make —

3. Push reservoir tank seals into cylinder body.
4. Push reservoir tank into cylinder body.

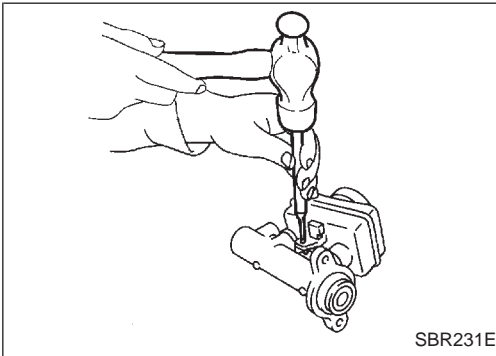

— For NABCO make —

3. Push reservoir tank seals and reservoir tank into cylinder body.
4. Install spring pin.

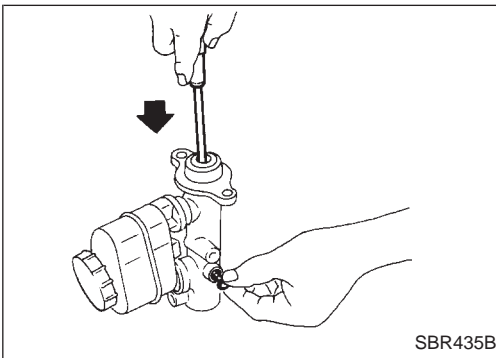

5. Install valve stopper while piston is pushed into cylinder.

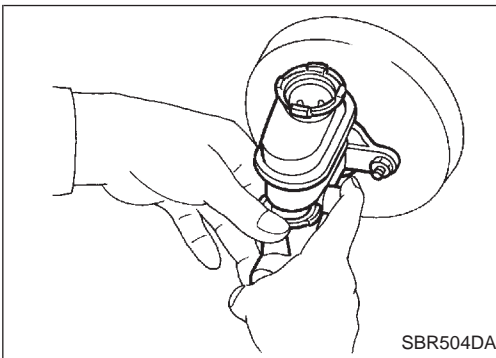

Installation

CAUTION:

- Refill with new brake fluid "DOT 3".
- Never reuse drained brake fluid.

1. Place master cylinder onto brake booster and secure mounting nuts lightly.
2. Torque mounting nuts.
 - Ⓜ: 12 - 15 N·m (1.2 - 1.5 kg·m, 9 - 11 ft·lb)
3. Bleed air from master cylinder.
 - a. Fill up reservoir tank with new brake fluid.
 - b. Plug all ports on master cylinder with fingers to prevent air suction while releasing brake pedal.
 - c. Have driver depress brake pedal slowly several times until no air comes out of master cylinder.
 - d. Fit brake lines to master cylinder.
 - e. Torque flare nuts.
 - Ⓜ: 15 - 17 N·m (1.5 - 1.7 kg·m, 11 - 12 ft·lb)
4. Bleed air from each caliper. Refer to "Bleeding Brake System", BR-7.

BRAKE BOOSTER

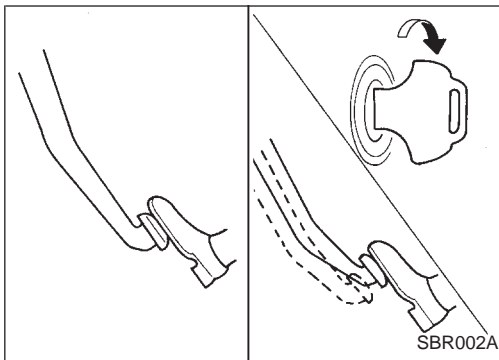

On-vehicle Service

OPERATING CHECK

- Depress brake pedal several times with engine off. After exhausting vacuum, make sure there is no change in pedal stroke.
- Depress brake pedal, then start engine. If pedal goes down slightly, operation is normal.

GI

MA

AIRTIGHT CHECK

- Start engine, and stop it after one or two minutes. Depress brake pedal several times slowly. Booster is airtight if pedal stroke is less each time.
- Depress brake pedal while engine is running, and stop engine with pedal depressed. The pedal stroke should not change after holding pedal down for **30 seconds**.

EM

LC

EC

FE

AT

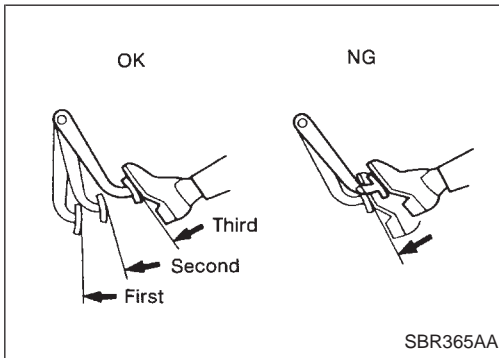

Removal

CAUTION:

- Be careful not to splash brake fluid on painted areas; it may cause paint damage. If brake fluid is splashed on painted areas, wash it away with water immediately.
- Be careful not to deform or bend brake pipes, during removal of booster.

PD

FA

RA

BR

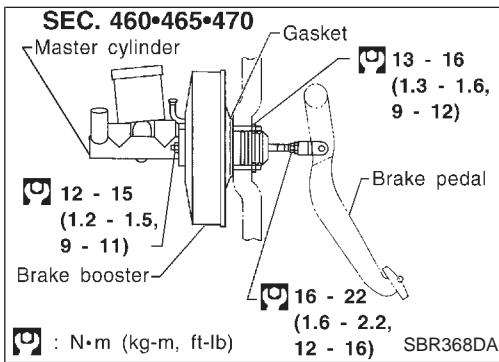

Inspection

Output rod length check

1. Apply vacuum of -66.7 kPa (-500 mmHg , -19.69 inHg) to brake booster with a handy vacuum pump.
2. Add preload of 19.6 N (2 kg , 4.4 lb) to output rod.
3. Check output rod length.

Specified length:

10.275 - 10.525 mm (0.4045 - 0.4144 in)

ST

RS

BT

HA

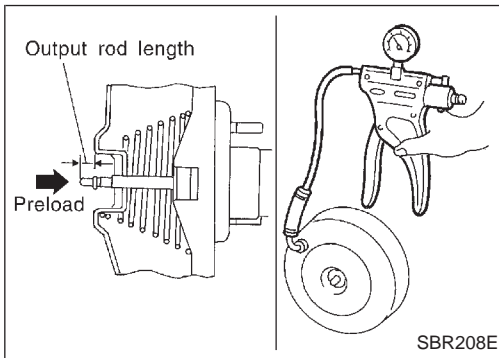

EL

Installation

CAUTION:



- Be careful not to deform or bend brake pipes during installation of booster.
- Replace clevis pin if damaged.
- Refill with new brake fluid "DOT 3".
- Never reuse drained brake fluid.
- Take care not to damage brake booster mounting bolt thread when installing. Due to the narrow angle of installation, the threads can be damaged by the dash panel.

IDX

BRAKE BOOSTER

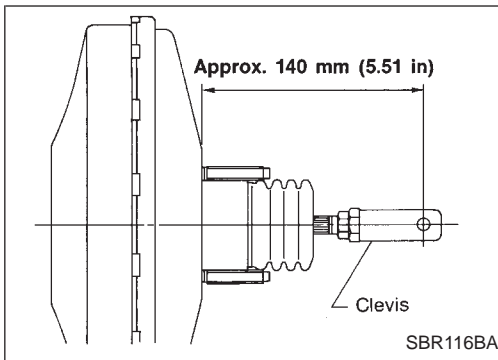
Installation (Cont'd)



1. Before fitting booster, temporarily adjust clevis to dimension shown.
2. Fit booster, then secure mounting nuts (brake pedal bracket to brake booster) lightly.
3. Connect brake pedal and booster input rod with clevis pin.
4. Secure mounting nuts.
 - : **13 - 16 N·m (1.3 - 1.6 kg-m, 9 - 12 ft-lb)**
5. Install master cylinder. Refer to "Installation" in "MASTER CYLINDER", BR-14.
6. Adjust brake pedal if necessary. Refer to "Adjustment" in "BRAKE PEDAL AND BRACKET", BR-10.
7. Secure lock nut for clevis.
 - : **16 - 22 N·m (1.6 - 2.2 kg-m, 12 - 16 ft-lb)**
8. Bleed air. Refer to "Bleeding Brake System", BR-7.

VACUUM HOSE

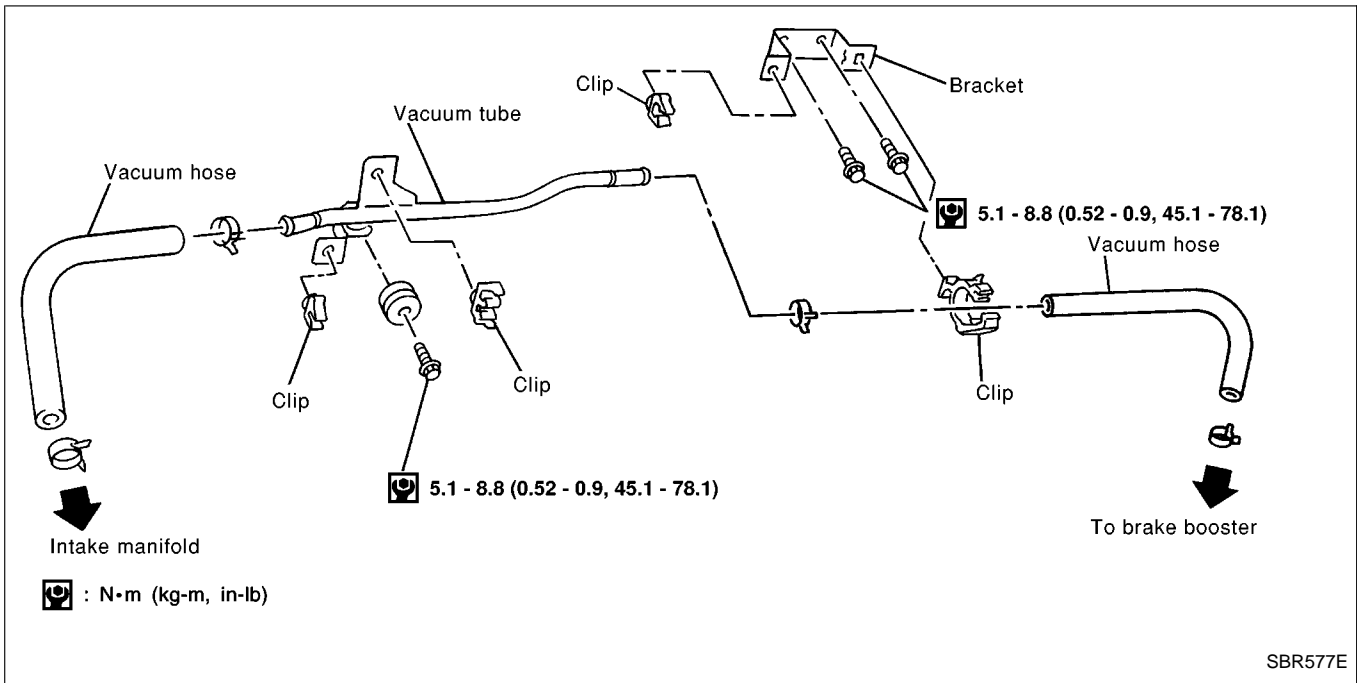

GI
MA
EM
LC
EC
FE
AT
PD
FA
RA
BR
ST
RS
BT
HA
EL
IDX

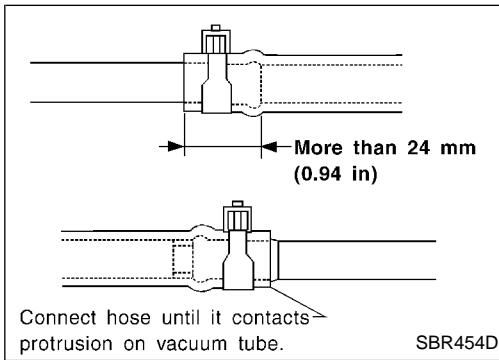

Removal and Installation

CAUTION:

When installing vacuum hoses, pay attention to the following points.

- Do not apply any oil or lubricants to vacuum hose and check valve.
- Insert vacuum tube into vacuum hose as shown.
- Install check valve, paying attention to its direction.

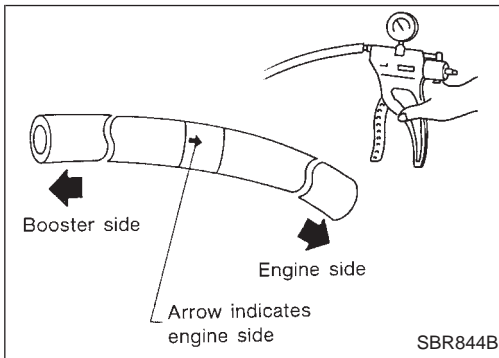

Inspection

CHECK VALVE

Check vacuum with a vacuum pump.

Connect to booster side	Vacuum should exist.
Connect to engine side	Vacuum should not exist.

Pad Replacement

WARNING:

Clean brakes with a vacuum dust collector to minimize the hazard of airborne particles or other materials.

CAUTION:

- When cylinder body is open, do not depress brake pedal, or piston will pop out.
- Be careful not to damage piston boot or get oil on rotor. Always replace shims when replacing pads.
- If shims are rusted or show peeling of the rubber coat, replace them with new shims.
- It is not necessary to remove connecting bolt except for disassembly or replacement of caliper assembly. In this case, suspend cylinder body with wire so as not to stretch brake hose.
- Carefully monitor brake fluid level because brake fluid will return to reservoir when pushing back piston.
- Burnish the brake contact surfaces after refinishing or replacing drums or rotors, after replacing pads or linings, or if a soft pedal occurs at very low mileage. Refer to "Brake Burnishing Procedure", "ON-VEHICLE SERVICE", BR-6.

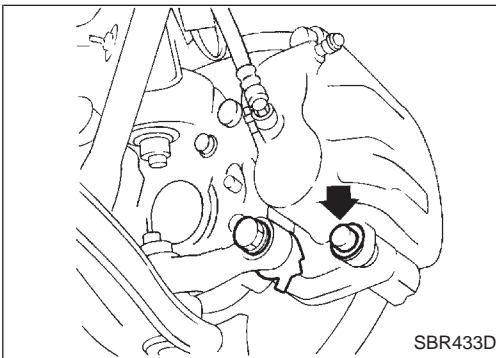

1. Remove master cylinder reservoir cap.
2. Remove lower pin bolt.

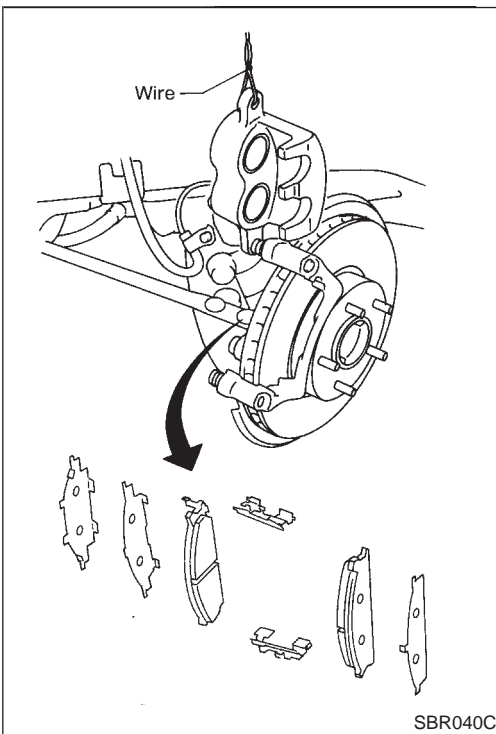

3. Open cylinder body upward. Then remove pad retainers, and inner and outer shims.

Standard pad thickness:

11.0 mm (0.433 in)

Pad wear limit:

2.0 mm (0.079 in)

- Carefully monitor brake fluid level because brake fluid will return to reservoir when pushing back piston.

FRONT DISC BRAKE

Components

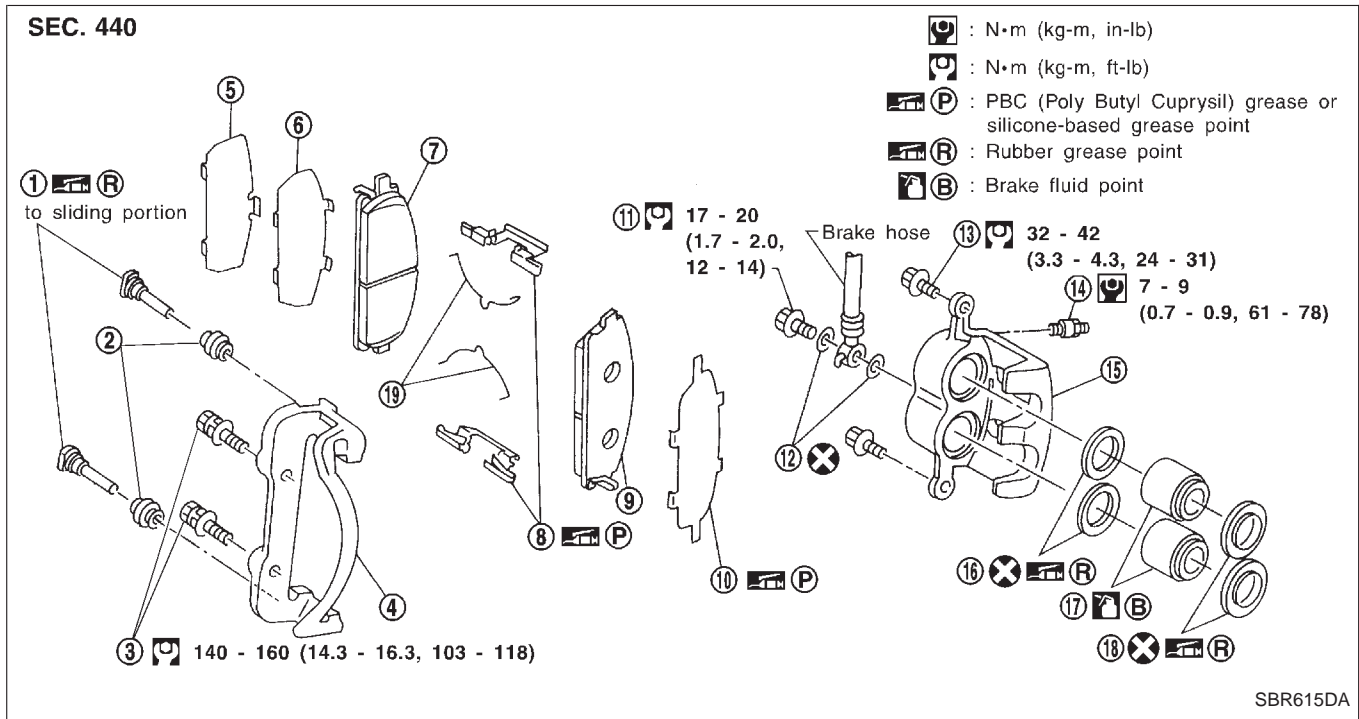

- ① Main pin
- ② Pin boot
- ③ Torque member fixing bolt
- ④ Torque member
- ⑤ Shim cover
- ⑥ Inner shim
- ⑦ Inner pad

- ⑧ Pad retainer
- ⑨ Outer pad
- ⑩ Outer shim
- ⑪ Connecting bolt
- ⑫ Copper washer
- ⑬ Main pin bolt

- ⑭ Bleed valve
- ⑮ Cylinder body
- ⑯ Piston seal
- ⑰ Piston
- ⑱ Piston boot
- ⑲ Pad spring

Removal

WARNING:

Clean brake pads with a vacuum dust collector to minimize the hazard of airborne particles or other materials.

CAUTION:

Suspend caliper assembly with wire so as not to stretch brake hose.

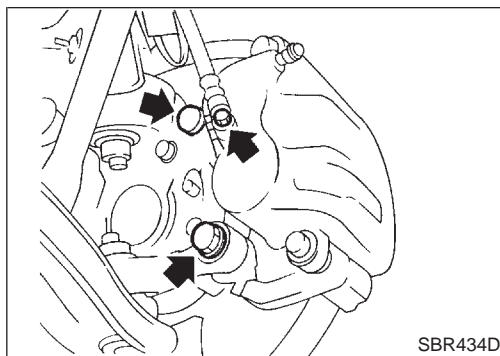

Remove torque member fixing bolts and connecting bolt.

It is not necessary to remove connecting bolt except for disassembly or replacement of caliper assembly. In this case, suspend caliper assembly with wire so as not to stretch brake hose.

GI
MA
EM
LC
EC
FE
AT
PD
FA
RA
BR
ST
RS
BT
HA
EL
IDX

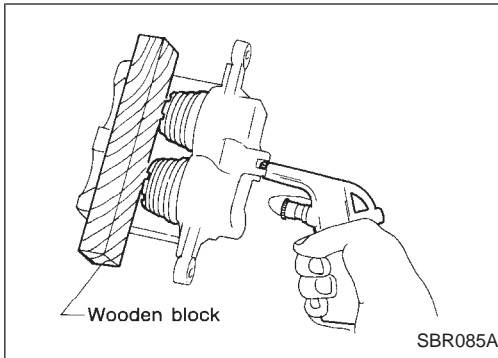

Disassembly

WARNING:

Do not place your fingers in front of piston.

CAUTION:

Do not scratch or score cylinder wall.

1. Push out piston with dust seal with compressed air.
2. Remove piston seal with a suitable tool.

Inspection — Caliper

CYLINDER BODY

- Check inside surface of cylinder for score, rust, wear, damage or presence of foreign objects. If any of the above conditions are observed, replace cylinder body.
- Minor damage from rust or foreign objects may be eliminated by polishing surface with a fine emery paper. Replace cylinder body if necessary.

CAUTION:

Use brake fluid to clean. Never use mineral oil.

PISTON

Check piston for score, rust, wear, damage or presence of foreign objects. Replace if any of the above conditions are observed.

CAUTION:

Piston sliding surface is plated. Do not polish with emery paper even if rust or foreign objects are stuck to sliding surface.

MAIN PIN, PIN BOLT AND PIN BOOT

Check for wear, cracks, rust or other damage. Replace if any of the above conditions are observed.

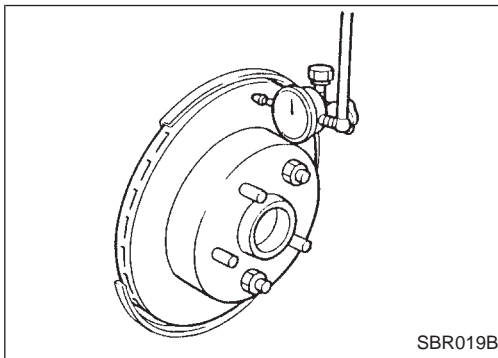

Inspection — Rotor

RUNOUT

1. Secure rotor to wheel hub with at least two nuts (M12 × 1.25).
2. Check runout using a dial indicator.

Make sure that wheel bearing axial end play is within the specifications before measuring. Refer to FA section, "Front Wheel Bearing".

Maximum runout:

0.07 mm (0.0028 in)

3. If the runout is out of specification, find minimum runout position as follows:
 - a. Remove nuts and rotor from wheel hub.
 - b. Shift the rotor one hole and secure rotor to wheel hub with nuts.
 - c. Measure runout.
 - d. Repeat steps a. to c. so that minimum runout position can be found.
4. If the runout is still out of specification, turn rotor with on-car brake lathe ("MAD, DL-8700", "AMMCO 700 and 705" or equivalent).

FRONT DISC BRAKE

Inspection — Rotor (Cont'd)

THICKNESS

Thickness variation (At least 8 positions):

Maximum 0.01 mm (0.0004 in)

If thickness variation exceeds the specification, turn rotor with on-car brake lathe.

Rotor repair limit:

26.0 mm (1.024 in)

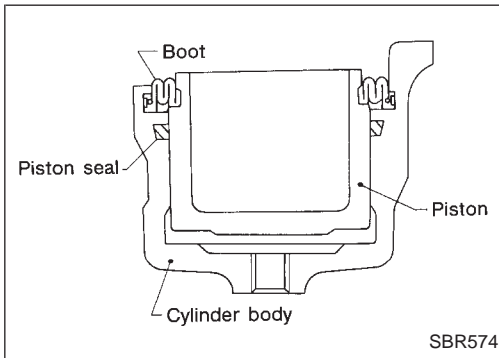
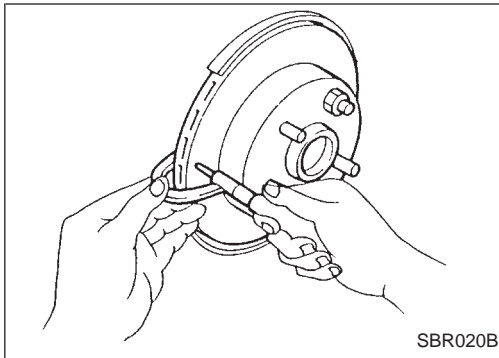

Assembly

1. Insert piston seal into groove on cylinder body.
2. With piston boot fitted to piston, insert piston boot into groove on cylinder body and install piston.
3. Properly secure piston boot

Installation

CAUTION:

- Refill with new brake fluid "DOT 3".
- Never reuse drained brake fluid.

1. Install caliper assembly.
2. Install brake hose to caliper securely.
3. Install all parts and secure all bolts.
4. Bleed air. Refer to "Bleeding Brake System", BR-7.

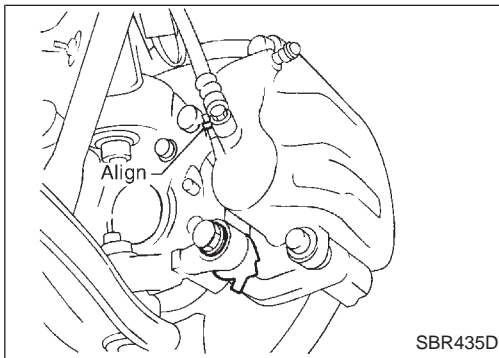

GI

MA

EM

LC

EC

FE

AT

PD

FA

RA

BR

ST

RS

BT

HA

EL

IDX

Pad Replacement

WARNING:

Clean brake pads with a vacuum dust collector to minimize the hazard of airborne particles or other materials.

CAUTION:

- When cylinder body is open, do not depress brake pedal, otherwise piston will pop out.
- Be careful not to damage piston boot or get oil on rotor. Always replace shims when replacing pads.
- If shims are rusted or show peeling of rubber coat, replace them with new shims.
- It is not necessary to remove connecting bolt except for disassembly or replacement of caliper assembly. In this case, suspend cylinder body with wire so as not to stretch brake hose.
- Carefully monitor brake fluid level because brake fluid will return to reservoir when pushing back piston.
- Burnish the brake contact surfaces after refinishing or replacing drums or rotors, after replacing pads or linings, or if a soft pedal occurs at very low mileage. Refer to “Brake Burnishing Procedure”, “ON-VEHICLE SERVICE”, BR-6.

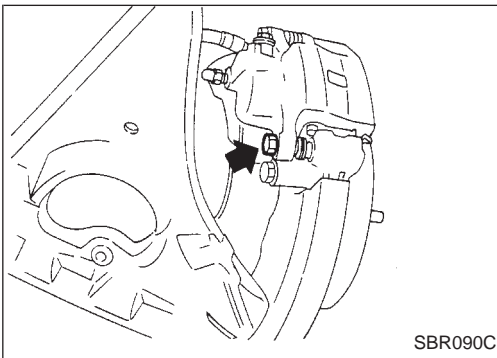

1. Remove master cylinder reservoir cap.
2. Remove lower pin bolt.

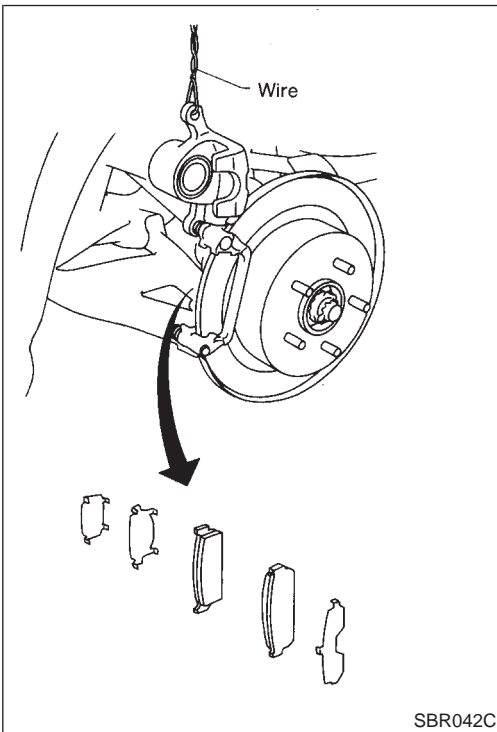

3. Open cylinder body upward. Then remove pad retainers, and inner and outer shims.
 - Standard pad thickness:**
10 mm (0.39 in)
 - Pad wear limit:**
2.0 mm (0.079 in)
- Carefully monitor brake fluid level because brake fluid will return to reservoir when pushing back piston.

REAR DISC BRAKE

Components

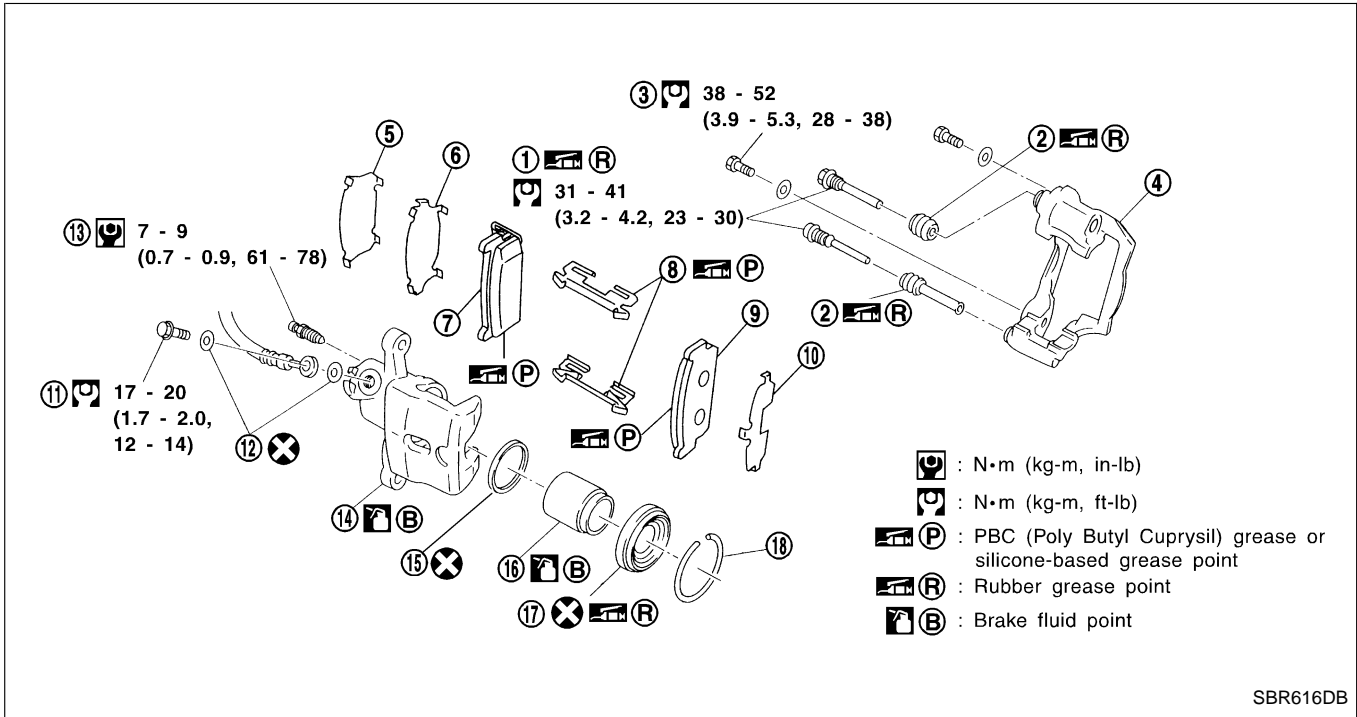

- | | | |
|-----------------------------|-------------------|-----------------|
| ① Main pin bolt | ⑦ Inner pad | ⑬ Bleed valve |
| ② Pin boot | ⑧ Pad retainer | ⑭ Cylinder body |
| ③ Torque member fixing bolt | ⑨ Outer pad | ⑮ Piston seal |
| ④ Torque member | ⑩ Outer shim | ⑯ Piston |
| ⑤ Shim cover | ⑪ Connecting bolt | ⑰ Piston boot |
| ⑥ Inner shim | ⑫ Copper washer | ⑱ Retainer |

Removal

WARNING:

Clean brakes with a vacuum dust collector to minimize the hazard of airborne particles or other materials.

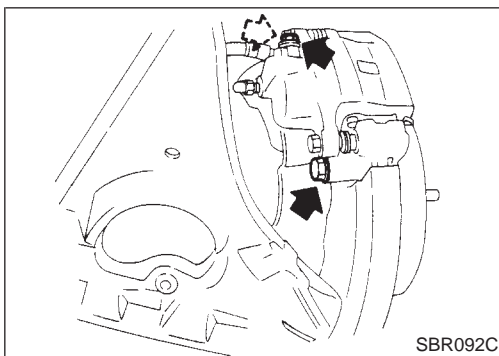

Remove torque member fixing bolts and connecting bolt.

It is not necessary to remove connecting bolt except for disassembly or replacement of caliper assembly. In this case, suspend caliper assembly with wire so as not to stretch brake hose.

GI
MA
EM
LC
EC
FE
AT
PD
FA
RA

BR

ST

RS

BT

HA

EL

IDX

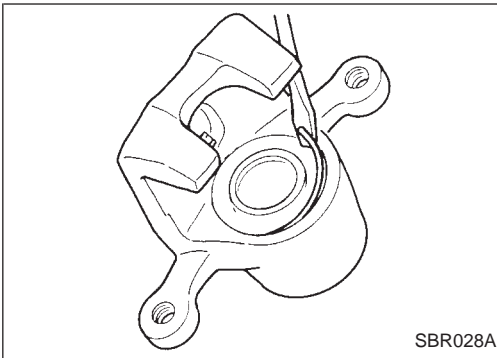

Disassembly

1. Remove piston boot retainer with a flat-bladed screwdriver.

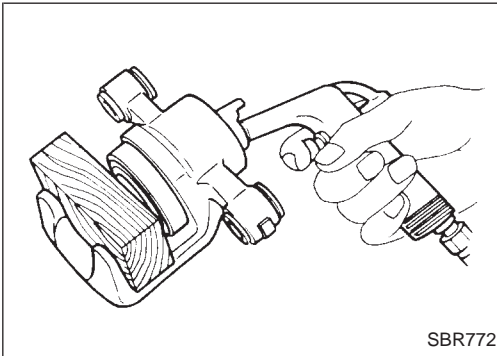

WARNING:

Do not place your fingers in front of piston.

CAUTION:

Do not scratch or score cylinder wall.

2. Push out piston and piston boot with compressed air.
3. Remove piston seal with a suitable tool.

Inspection — Caliper

CYLINDER BODY

- Check inside surface of cylinder for score, rust, wear, damage or presence of foreign objects. If any of the above conditions are observed, replace cylinder body.
- Minor damage from rust or foreign objects may be eliminated by polishing surface with a fine emery paper. Replace cylinder body if necessary.

CAUTION:

Use brake fluid to clean cylinder. Never use mineral oil.

PISTON

CAUTION:

Piston sliding surface is plated. Do not polish with emery paper even if rust or foreign objects are stuck to sliding surface.

Check piston for score, rust, wear, damage or presence of foreign objects. Replace if any of the above conditions are observed.

MAIN PIN, PIN BOLT AND PIN BOOT

Check for wear, cracks, rust or other damage. Replace if any of the above conditions are observed.

Inspection — Rotor

RUBBING SURFACE

Check rotor for roughness, cracks or chips.

REAR DISC BRAKE

Inspection — Rotor (Cont'd)

RUNOUT

1. Secure rotor to wheel hub with two nuts (M12 x 1.25).
2. Check runout using a dial indicator.

Make sure that wheel bearing axial end play is within the specifications before measuring. Refer to RA section, "Rear Wheel Bearing".

Maximum runout:

0.07 mm (0.0028 in)

3. If the runout is out of specification, find minimum runout position as follows:
 - a. Remove nuts and rotor from wheel hub.
 - b. Shift the rotor one hole and secure rotor to wheel hub with nuts.
 - c. Measure runout.
 - d. Repeat steps a. to c. so that minimum runout position can be found.
4. If the runout is still out of specification, turn rotor with on-car brake lathe ("MAD, DL-8700", "AMMCO 700 and 705" or equivalent).

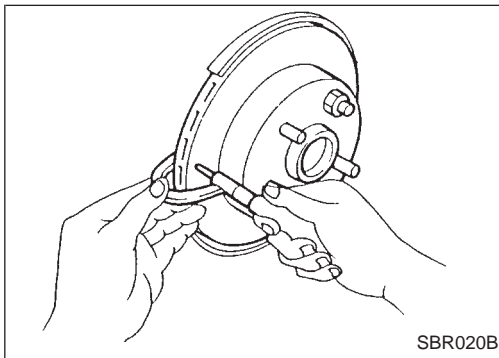
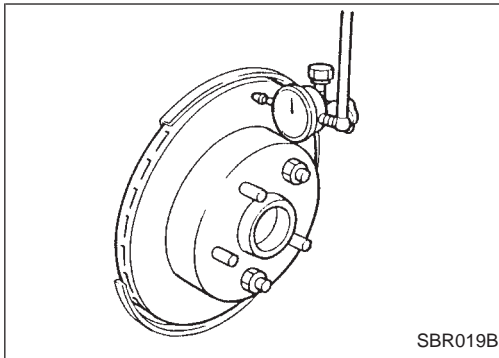

THICKNESS

Rotor repair limit:

Minimum thickness

14.0 mm (0.551 in)

Thickness variation (At least 8 portions)

Maximum 0.02 mm (0.0008 in)

If thickness variation exceeds the specification, turn rotor with on-car brake lathe.

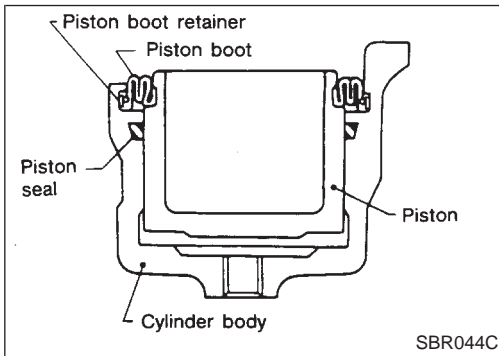

Assembly

1. Insert piston seal into groove on cylinder body.
2. With piston boot fitted to piston, insert piston boot into groove on cylinder body and install piston.
3. Properly secure piston boot.
4. Secure piston boot with retainer.

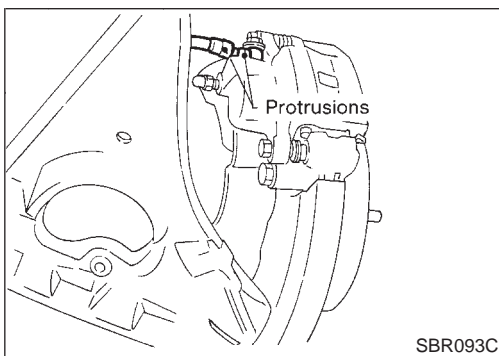

Installation

CAUTION:

- Refill with new brake fluid "DOT 3".
- Never reuse drained brake fluid.

1. Install caliper assembly.
2. Install brake hose to caliper securely.
3. Install all parts and secure all bolts.
4. Bleed air. Refer to "Bleeding Brake System", BR-7.

GI

MA

EM

LC

EC

FE

AT

PD

FA

RA

BR

ST

RS

BT

HA

EL

IDX

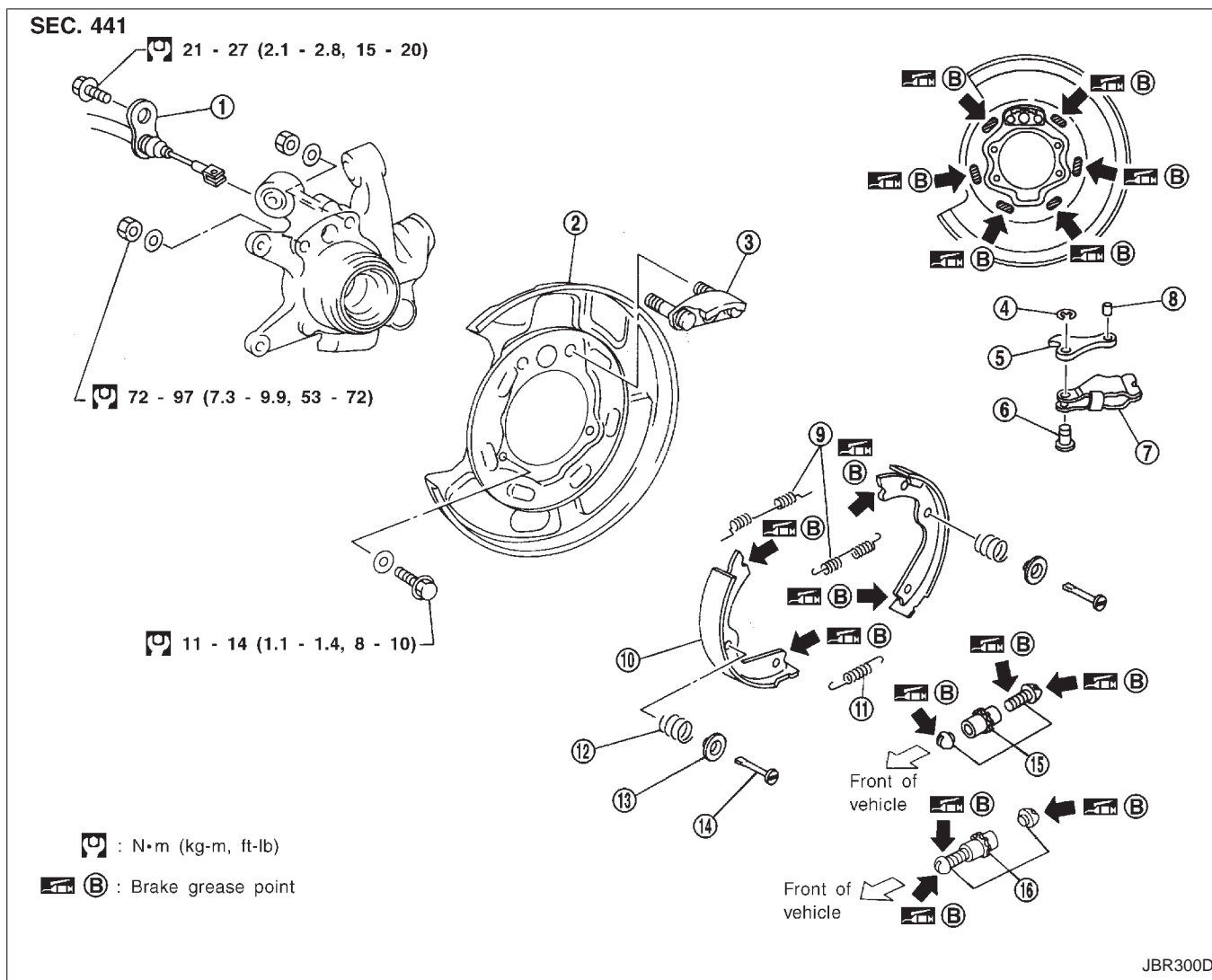

- ① Parking brake cable
- ② Back plate
- ③ Anchor block
- ④ E-ring
- ⑤ Lever
- ⑥ Pin

- ⑦ Toggle lever
- ⑧ Stopper pin
- ⑨ Return spring
- ⑩ Shoe
- ⑪ Adjuster spring

- ⑫ Anti-rattle spring
- ⑬ Retainer
- ⑭ Anti-rattle pin
- ⑮ Adjuster assembly LH
- ⑯ Adjuster assembly RH

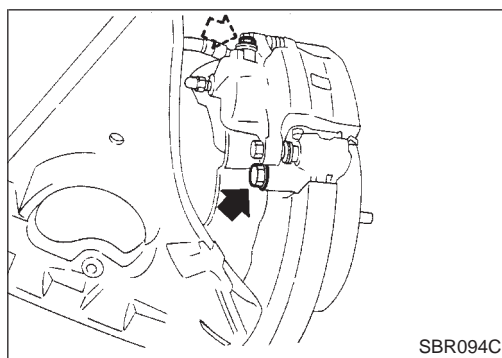

Removal

WARNING:

Clean brakes with a vacuum dust collector to minimize the hazard of airborne particles or other materials.

CAUTION:

Make sure parking brake lever is released completely.

1. Remove torque member fixing bolts (Rear disc brake assembly mounting bolts).

Suspend caliper assembly with wire so as not to stretch brake hose.

REAR DISC BRAKE — Parking Drum Brake

Removal (Cont'd)

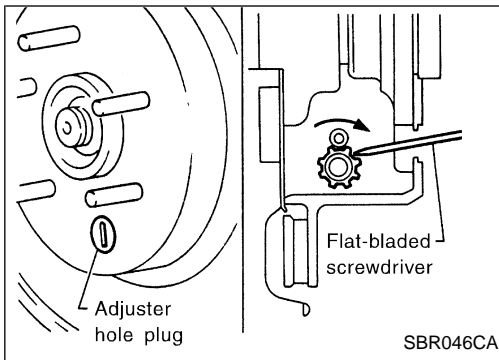

2. Release parking brake lever fully, then remove drum.

If drum is hard to remove, the following procedures should be carried out.

- a. Remove plug.
- b. Insert flat-bladed screwdriver through plug hole.
- c. Turn adjuster to make clearance between brake shoe and drum.

GI

MA

EM

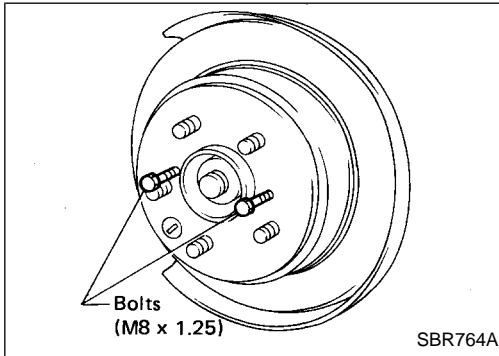

d. Fit two bolts to the drum as shown and tighten gradually.

LC

EC

FE

AT

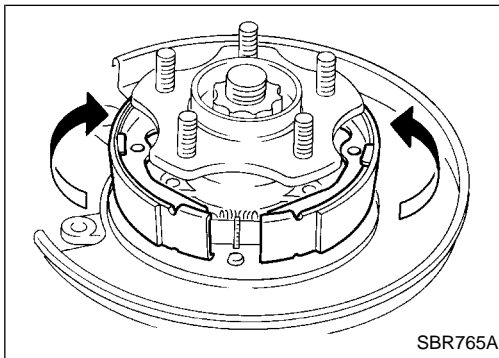

3. After removing retainer, remove spring by rotating shoes.

4. Remove adjuster.

PD

FA

RA

BR

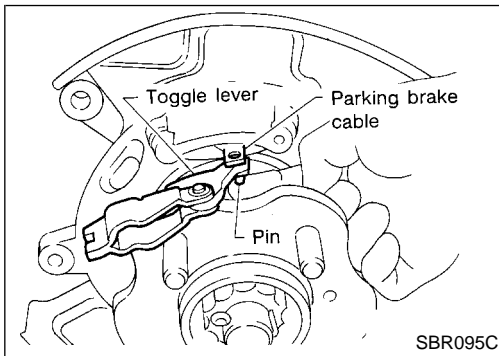

5. Disconnect parking brake cable from toggle lever after drawing out toggle lever pin.

ST

RS

BT

HA

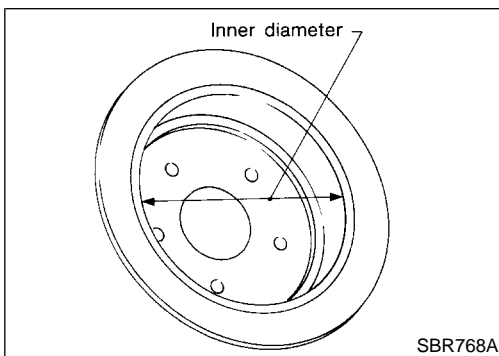

Inspection — Drum

**Maximum inner diameter:
173.0 mm (6.81 in)**

EL

IDX

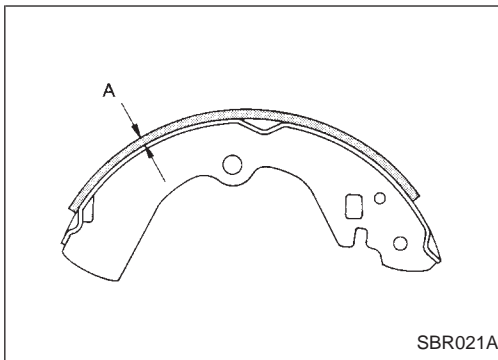

Inspection — Lining

Check lining thickness.

Standard lining thickness:

3.2 mm (0.126 in)

Lining wear limit (A):

1.5 mm (0.059 in)

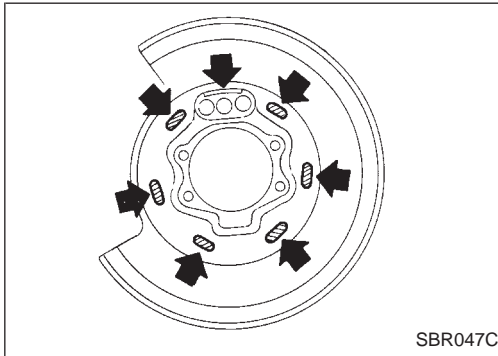

Installation

1. Apply brake grease to the contact areas shown at left.

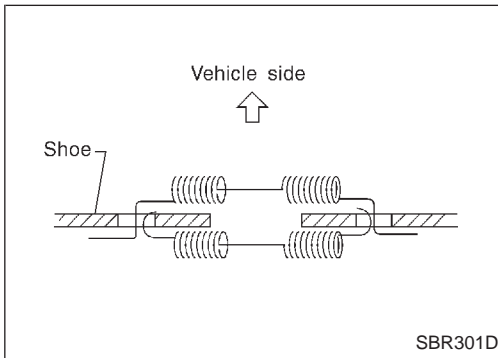

2. Attach two upper springs to brake shoes as shown in the figure at left.

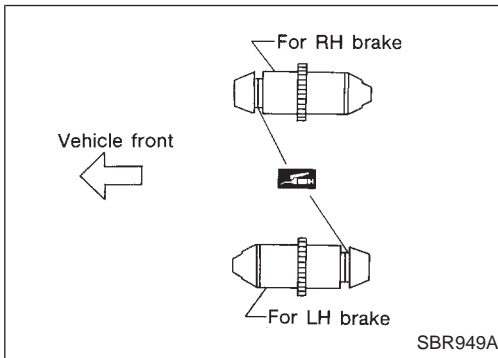

3. Shorten adjuster by rotating it.

Pay attention to direction of adjuster.

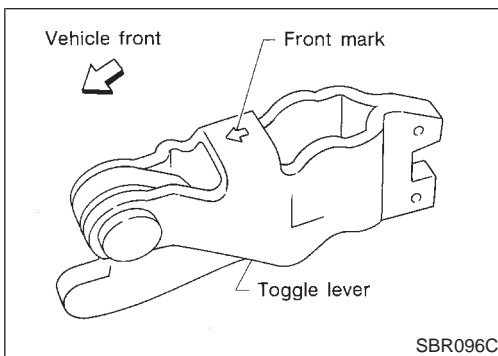

4. Connect parking brake cable to toggle lever.

Pay attention to direction of adjuster.

5. Install all parts.

REAR DISC BRAKE — Parking Drum Brake

Installation (Cont'd)

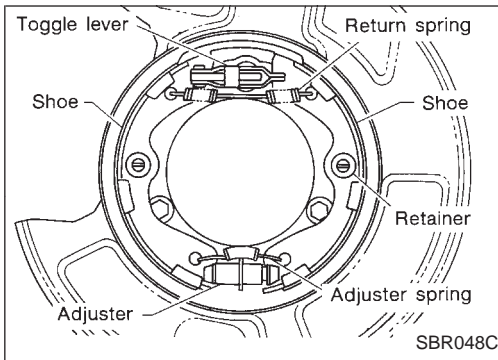

6. Check all parts are installed properly.
Pay attention to direction of adjuster and toggle lever.
7. Install drum.
8. Install rear disc brake assembly.

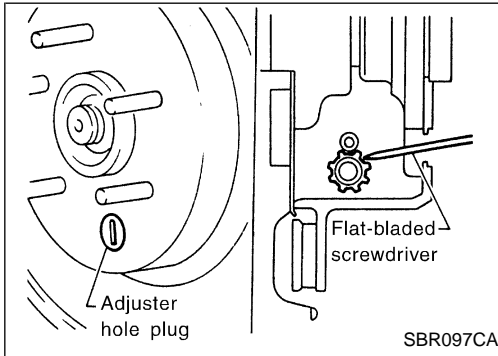

Shoe Clearance Adjustment

1. Remove adjuster hole plug, and turn down adjuster wheel with a flat-bladed screwdriver until brake is locked.
Make sure that parking control lever is released completely.
2. Return adjuster wheel 5 to 6 latches.
3. Install adjuster hole plug, and make sure that there is no drag between shoes and brake drum when rotating disc rotor.
4. Adjust parking brake cable. Refer to "Adjustment" in "PARKING BRAKE CONTROL", BR-31.

Breaking in Drum and Lining

When a new rotor/parking brake shoe is installed, or when braking performance is poor, perform the following break-in procedure.

1. Drive the unloaded vehicle on a safe, level and dry road.
2. Depress parking brake pedal with a force of 147 N (15 kg, 33 lb).
3. While depressing the pedal, continue to drive the vehicle forward 100 m (328 ft) at approximately 35 km/h (22 MPH).
4. Cool down parking brake for approx. five minutes.
5. After releasing the pedal, drive the vehicle under the normal conditions for two minutes to cool down the parking drum brake.
6. Repeat steps 1 through 5 three times and then repeat only step 5 one more time.

GI

MA

EM

LG

EC

FE

AT

PD

FA

RA

BR

ST

RS

BT

HA

EL

IDX

PARKING BRAKE CONTROL

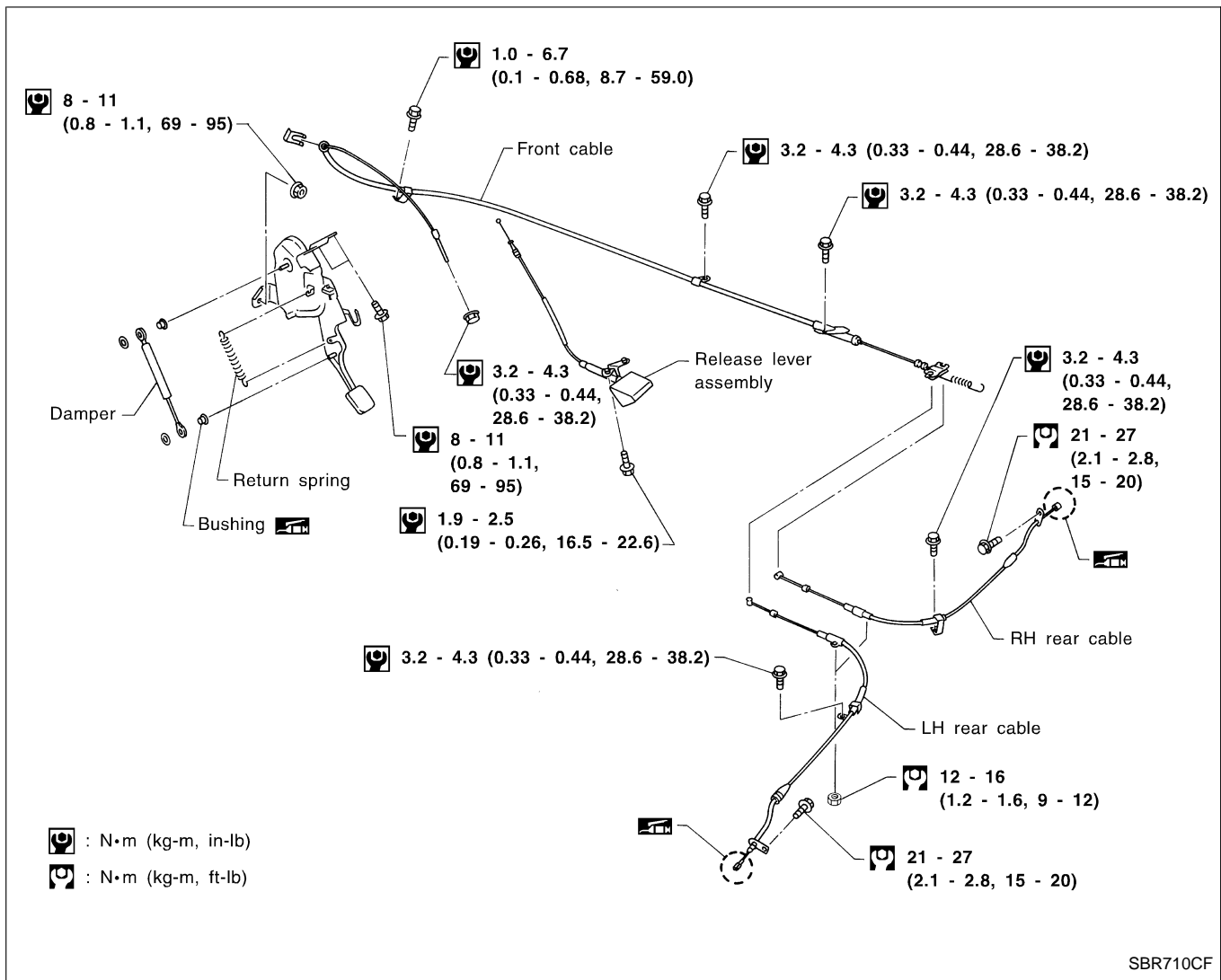

Removal and Installation

- Parking brake cables can be removed without removing pedal assembly.
- In order to remove front cable, it is necessary to remove center console. (Refer to BT section, "INSTRUMENT PANEL".)
- In order to remove pedal assembly, it is necessary to remove instrument panel assembly and air duct. (Refer to BT section, "INSTRUMENT PANEL".)

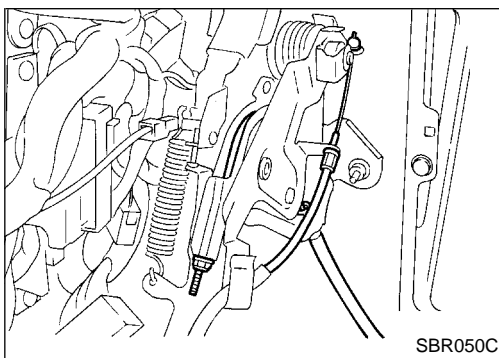

- The figure at left shows how front and release cables are connected to pedal assembly.

PARKING BRAKE CONTROL

Inspection

1. Check control lever for wear or other damage. Replace if necessary.
2. Check wires for discontinuity or deterioration. Replace if necessary.
3. Check warning lamp and switch. Replace if necessary.
4. Check parts at each connecting portion and, if deformed or damaged, replace.

GI

MA

Adjustment

On models equipped with parking drum brake, perform shoe clearance adjustment before adjusting parking brake control. Refer to "Shoe Clearance Adjustment" in "REAR DISC BRAKE — Parking Drum Brake" (BR-29).

EM

LC

EC

FE

AT

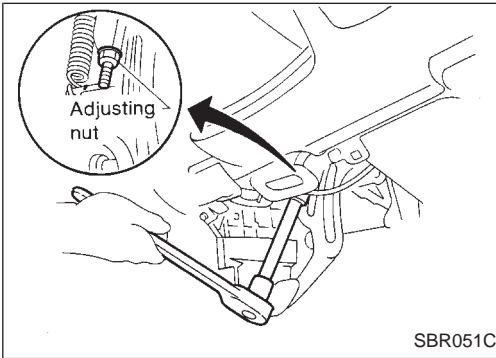

SBR051C

1. Release parking brake pedal and loosen adjusting nut. Adjust parking brake by turning adjusting nut.

PD

FA

RA

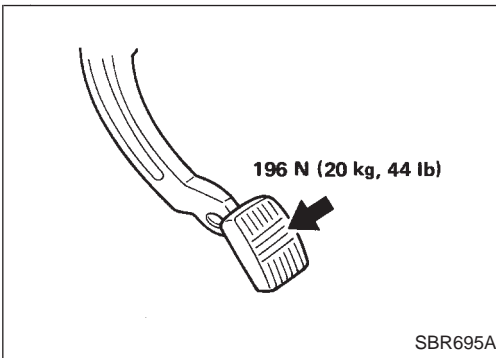

SBR695A

2. Depress parking brake pedal several times with specified amount of force. Check pedal stroke and ensure smooth operation.

Pedal stroke:

88 - 103 mm (3.46 - 4.06 in)

BR

ST

RS

BT

HA

3. Warning lamp comes on when parking brake pedal is depressed "A" mm ("A" in).

"A": 29 mm (1.14 in) or less

EL

IDX

Purpose

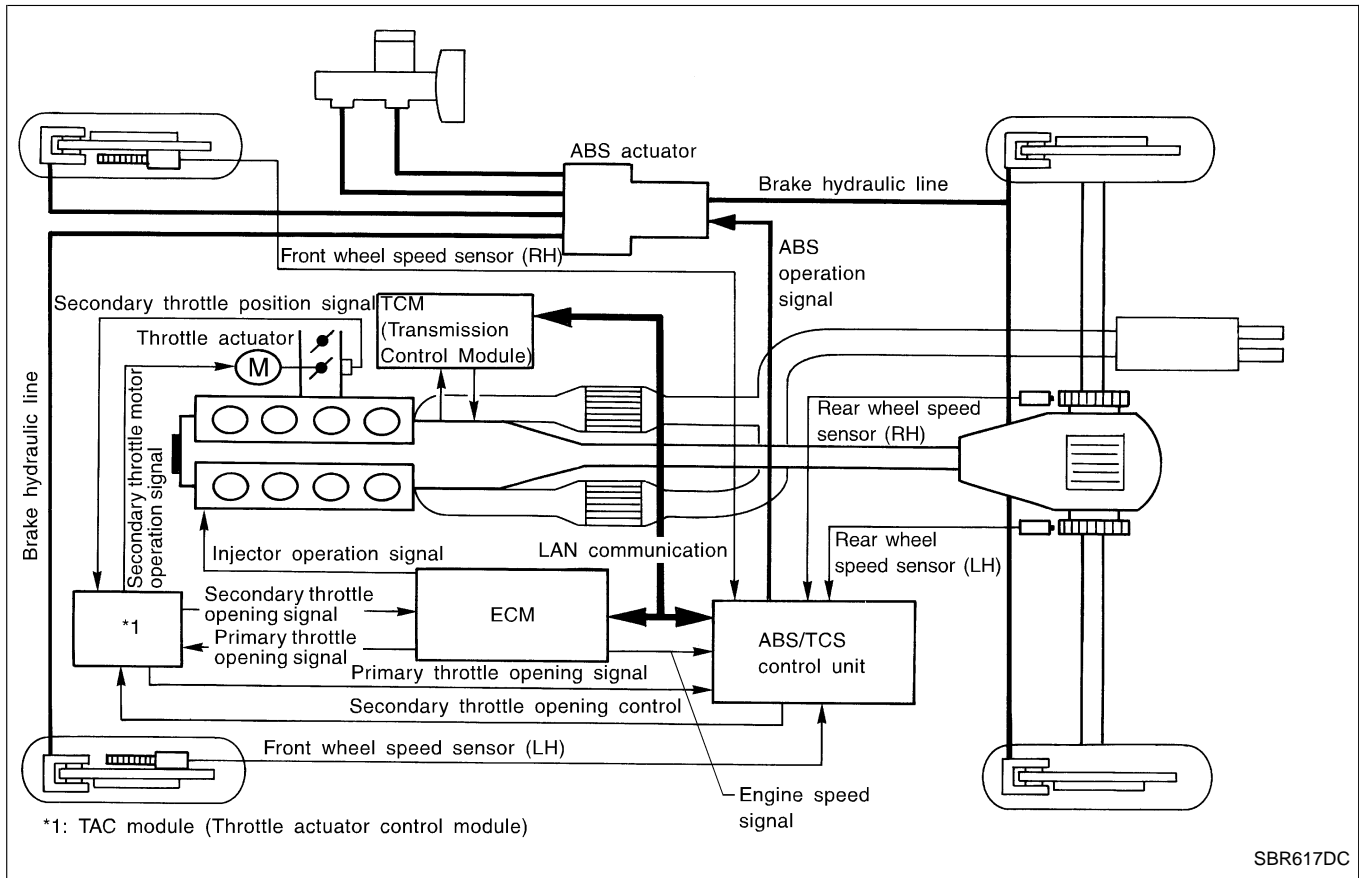

The ABS (anti-lock brake system)/TCS (traction control system) allows for mutual communication between the following two systems.

1. The Anti-Lock Brake System (ABS) consists of electronic and hydraulic components. It allows for control of braking force so locking of the wheels can be avoided.
The ABS:
 - (1) Improves proper tracking performance through steering wheel operation.
 - (2) Eases obstacle avoidance through steering wheel operation.
 - (3) Improves vehicle stability.
2. The TCS (traction control system) controls engine torque via throttle and fuel-cut control systems and A/T shift schedule, preventing the drive wheels from spinning. This in turn prevents the vehicle rear end from skidding to either side, resulting in improved starting ability, acceleration, as well as overall vehicle stability.

System Components

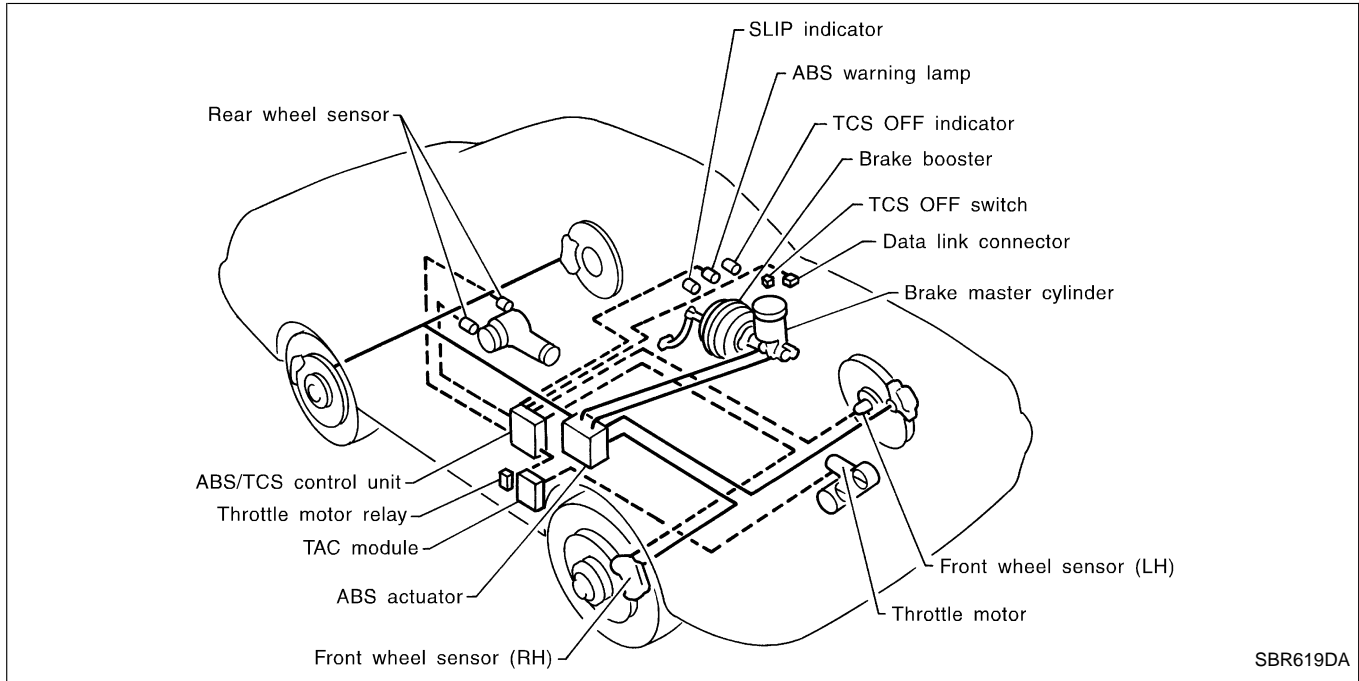

SBR619DA

Component parts	Description
Wheel sensor	Senses or detects each wheel rotation speed.
ABS/TCS control unit	Receives signals from all wheel sensors and sends a control signal to TAC module, ECM and TCM. If electrical system becomes inoperative, fail-safe function will activate, operating the vehicle similar to a vehicle which is not equipped with TCS. When fail-safe function activates, TCS OFF indicator and TCS SLIP indicator light. These indicators are located in the meter cluster. The self-diagnostic function supports the CONSULT-II. The self-diagnostic result is also indicated by the SLIP indicator.
TAC module	Receives a signal from ABS/TCS control unit in order to control throttle actuator. Throttle motor operation will then be controlled for regulating throttle positioning. If throttle motor control system becomes inoperative, throttle motor operation will be suspended. TAC module will then activate fail-safe function. The self-diagnostic result is indicated by the control unit LED. The self-diagnostic function supports the CONSULT-II.
Throttle actuator	Receives a signal from TAC module and activates throttle motor.
ECM	Receives a signal from ABS/TCS control unit and provides fuel-cut control. This in turn regulates engine drive torque.
TCM	Receives a signal from ABS/TCS control unit and provides shifting control.
SLIP indicator	Lights in conjunction with TCS operation. Also indicates self-diagnostic result for TCS.
TCS OFF indicator	Lights when TCS is "OFF" (TCS switch "ON"), indicating that TCS is not operating.
TCS OFF switch	Set to "ON" to deactivate TCS.

GI
MA
EM
LC
EC
FE
AT
PD
FA
RA
BR
ST
RS
BT
HA
EL
IDX

ABS (Anti-lock brake system) Operation

- When the vehicle speed is less than 10 km/h (6 MPH) this system does not work.
- The Anti-Lock Brake System (ABS) has a self-test function. The system turns on the ABS warning lamp for 1 second each time the ignition switch is turned "ON". After the engine is started, the ABS warning lamp turns off. The system performs a test the first time the vehicle reaches 6 km/h (4 MPH). A mechanical noise may be heard as the ABS performs this self-test. This is a normal part of the self-test feature. If a malfunction is found during this check, the ABS warning lamp will stay on.
- While driving, a mechanical noise may be heard during ABS operation. This is a normal condition.

ABS Hydraulic Circuit

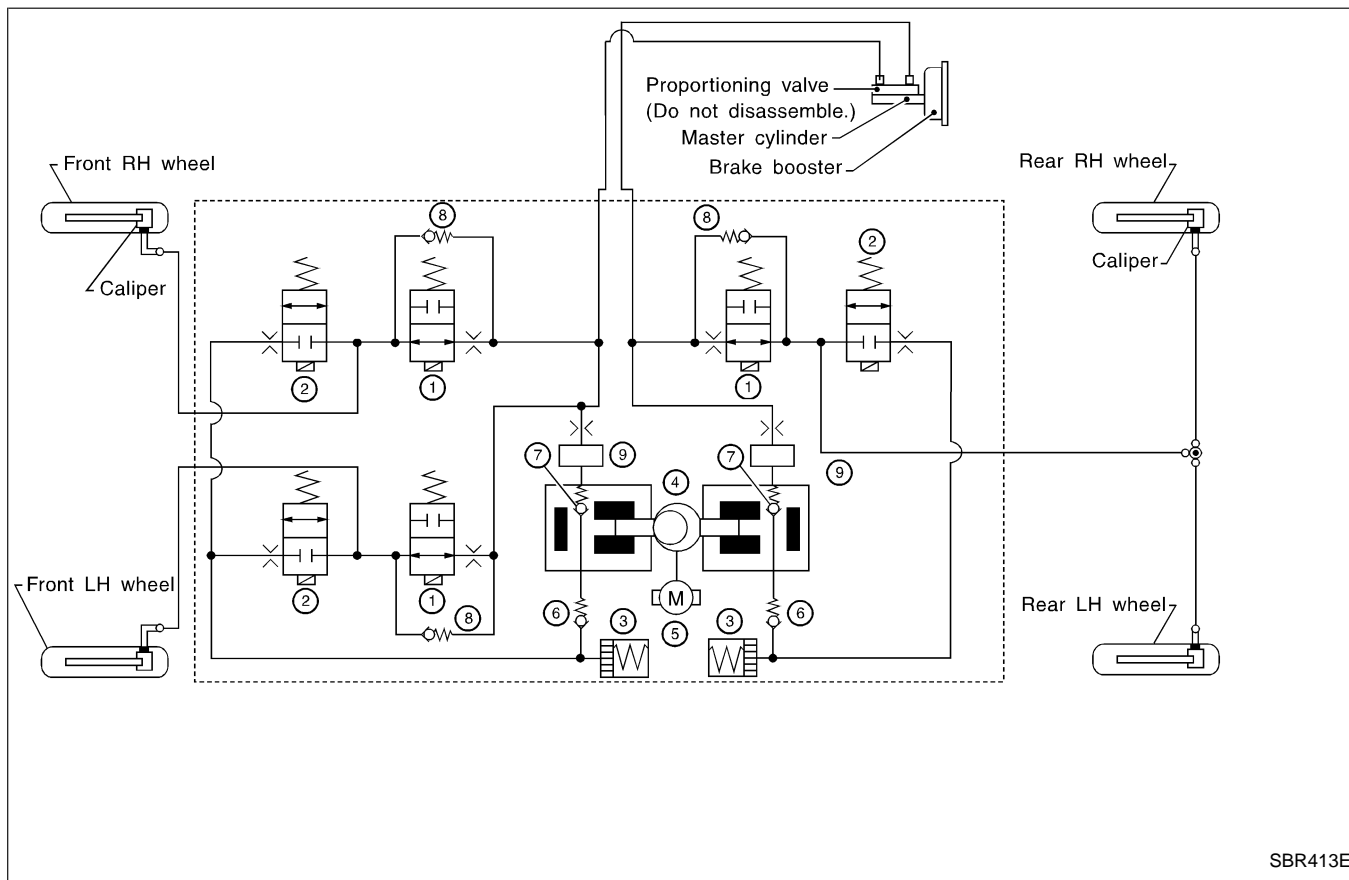

- | | | |
|-------------------------|---------------|----------------------|
| ① Inlet solenoid valve | ④ Pump | ⑦ Outlet valve |
| ② Outlet solenoid valve | ⑤ Motor | ⑧ Bypass check valve |
| ③ Reservoir | ⑥ Inlet valve | ⑨ Damper |

TCS (Traction Control System) Operation

This system has a secondary throttle valve which is opened/closed by a throttle motor. This is in addition to the primary throttle valve linked to the accelerator pedal. The opening angle of this valve is feed-back controlled by the secondary throttle sensor.

The secondary throttle valve is normally kept in the fully opened position. When a slip of the drive wheels is detected by the wheel sensor, the TCS control unit determines the optimum opening position of the secondary throttle valve. The Throttle Actuator Control (TAC) Module then closes the secondary throttle valve to the correct position according to this information. It then reduces the engine output torque, and so avoids occurrence of slip. At the same time, a signal sent from the TCS control unit allows the ECM to cut fuel supply. The TCS control unit needs the primary throttle valve position signal to determine the secondary throttle valve opening position. The TAC module receives the throttle sensor position signal through the ECM, and the TAC module sends the signal to the TCS control unit.

If the TAC module detects trouble in the throttle valve control system, it de-energizes a relay located up-stream of the throttle motor power supply. The secondary throttle valve is then opened fully by means of a return spring. In this case, ordinary vehicle operation is assured by the functioning of the primary throttle valve. At the same time, the TAC module stops sending the throttle position sensor signal to the TCS control unit.

Throttle Control + Engine Control TCS System Configuration (Tandem Throttle System)

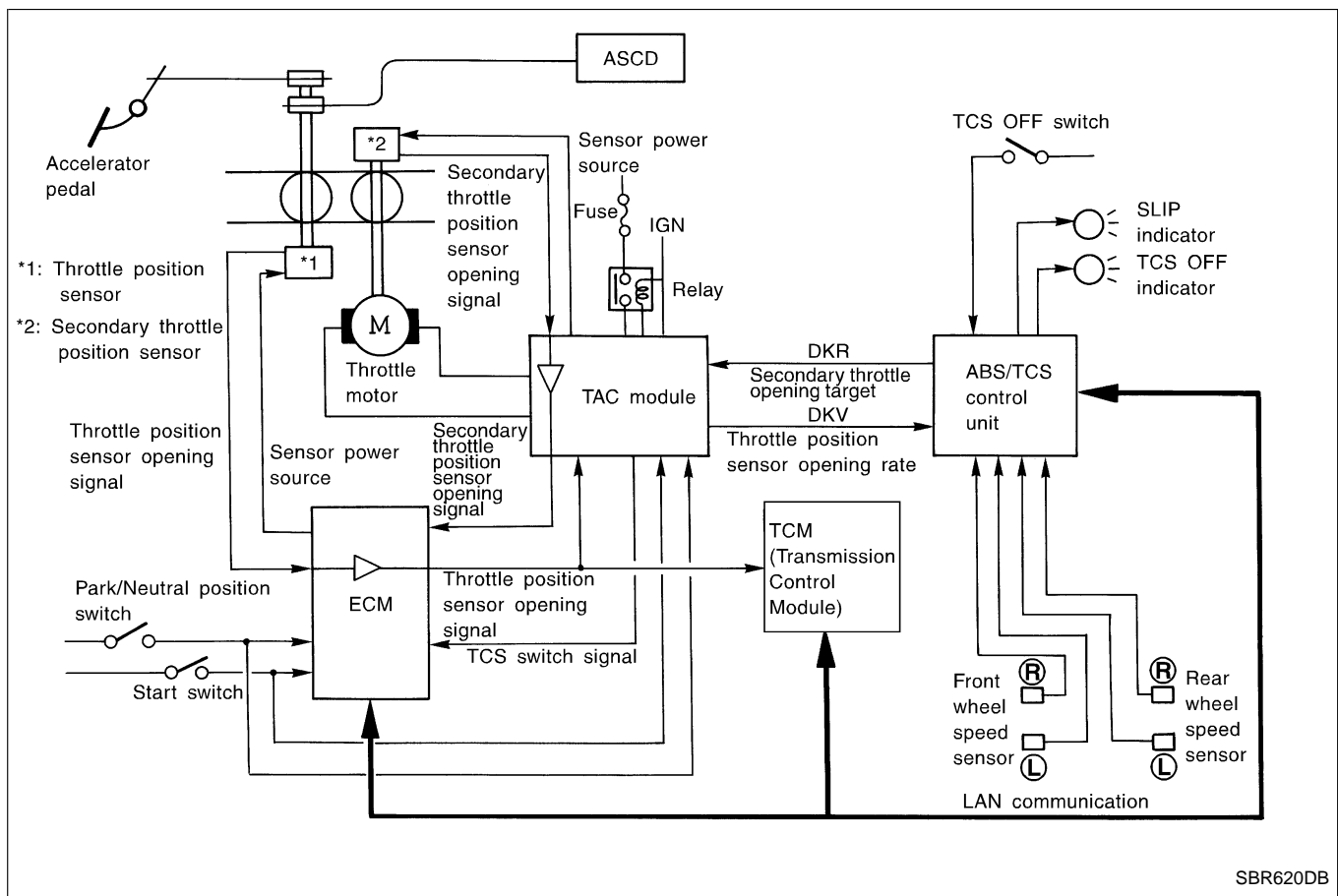

SBR620DB

GI
MA
EM
LC
EC
FE
AT
PD
FA
RA
BR
ST
RS
BT
HA
EL
IDX

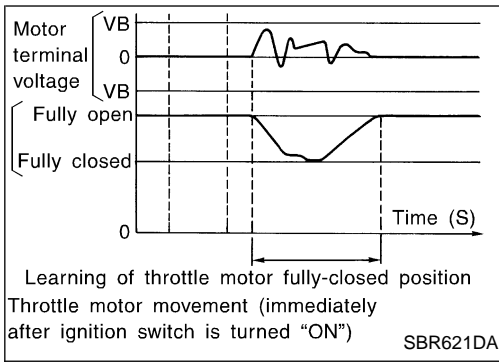

Secondary Throttle Fully-closed Position Self-learning Control

When a certain condition occurs with ignition switch ON, the TAC module checks for operation of the throttle control system. It does this by fully closing the secondary throttle and then opening it fully. Simultaneously, the TAC module reads the secondary throttle position sensor output values at both the fully closed/opened positions. This data is used for self-diagnosing the secondary throttle driving system. The same data is also used for improving the control accuracy of the secondary throttle.

This learning control is performed at the moment the ignition switch is turned ON under conditions: Automatic transmission is set in "N" or "P" position; Accelerator pedal is released completely.

Removal and Installation

CAUTION:

Be careful not to damage sensor edge and sensor rotor teeth. When removing the front wheel hub or final drive assemblies, first remove the ABS wheel sensor from the assembly. Failure to do so may result in damage to the sensor wires making the sensor inoperative.

WHEEL SENSORS

SEC. 476

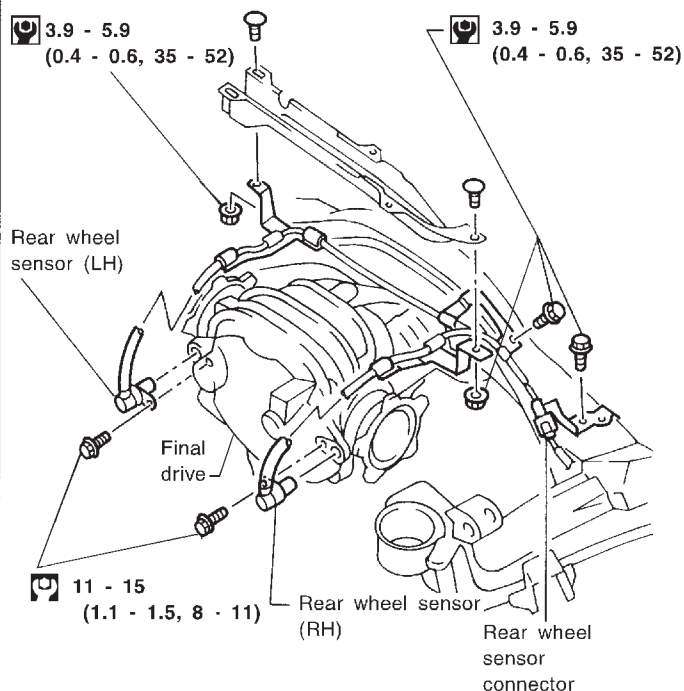
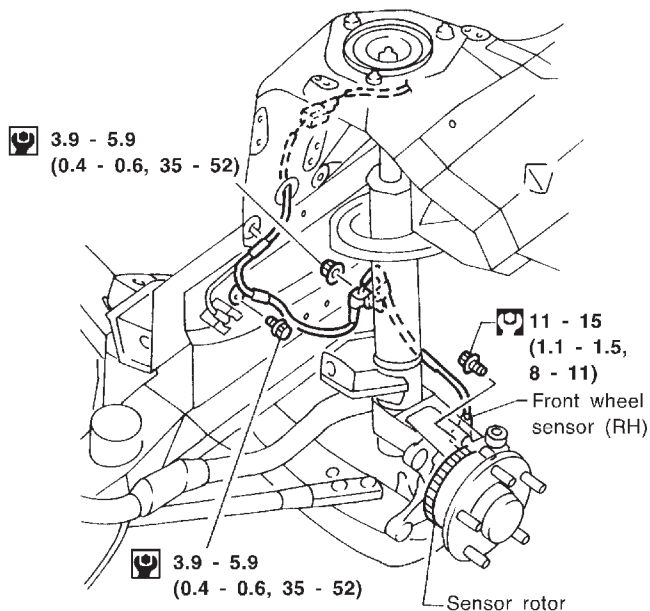
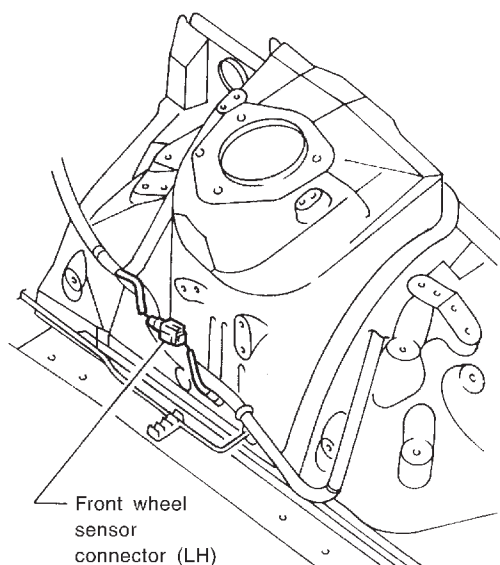
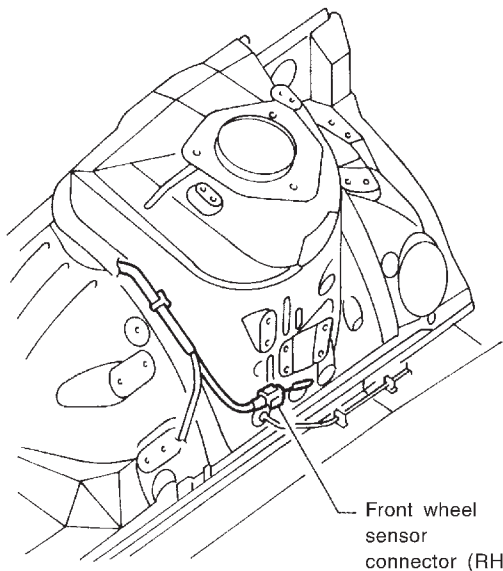

: N•m (kg-m, in-lb)

: N•m (kg-m, ft-lb)

SBR622DA

GI

MA

EM

LC

EC

FE

AT

PD

FA

RA

BR

ST

RS

BT

HA

EL

IDX

Removal and Installation (Cont'd)

SENSOR ROTOR

Removal

1. Remove the front wheel hub or final drive companion flange. Refer to FA section, "FRONT AXLE" and PD section.
2. Remove the sensor rotor using suitable puller, drift and bearing replacer.

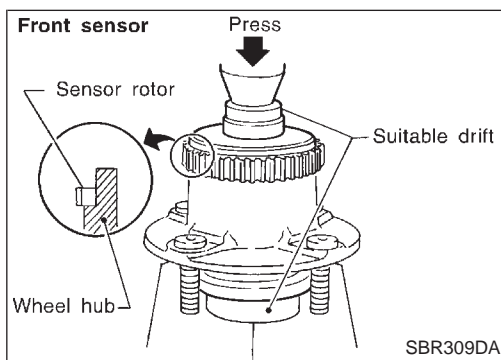
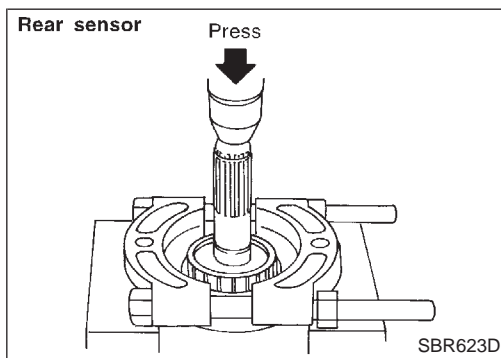
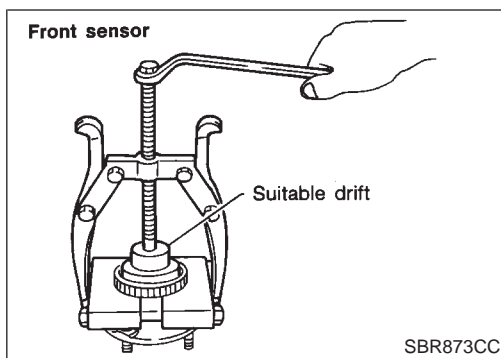

Installation

Install the sensor rotor using suitable drift and press.

- Always replace sensor rotor with new one.
- Pay attention to the direction of front sensor rotor as shown in figure.

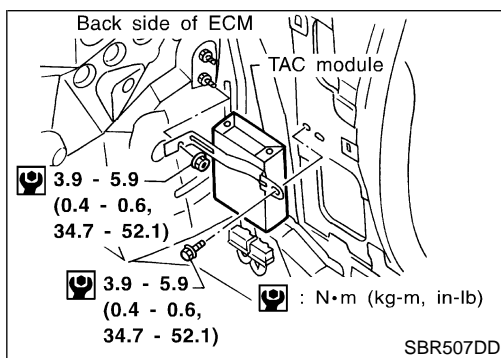
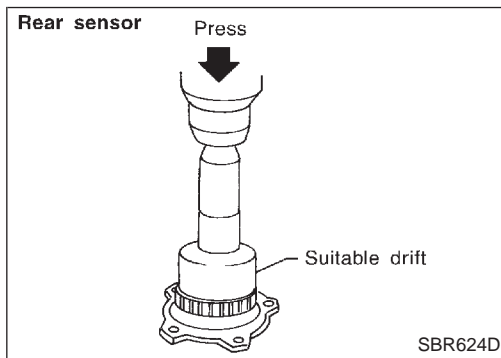

CONTROL UNIT (TAC module)

CAUTION:

- When disconnecting or connecting connectors, check terminals to ensure that they are not bent or otherwise damaged.
- When installing trunk trim clips, be careful not to bend control unit bracket or bump control unit.

Location: Passenger side, behind dash side lower finisher.

TRACTION CONTROL SYSTEM — TCS —

Removal and Installation (Cont'd) CONTROL UNIT (ABS/TCS control unit)

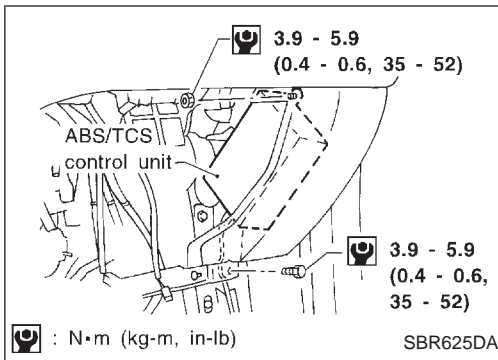

CAUTION:

- When disconnecting or connecting connectors, check terminals to ensure that they are not bent or otherwise damaged.
- When installing trunk trim clips, be careful not to bend control unit bracket or bump control unit.

Location: Inside instrument panel on passenger's seat side, near front pillar

ACTUATOR (ABS relay built-in type)

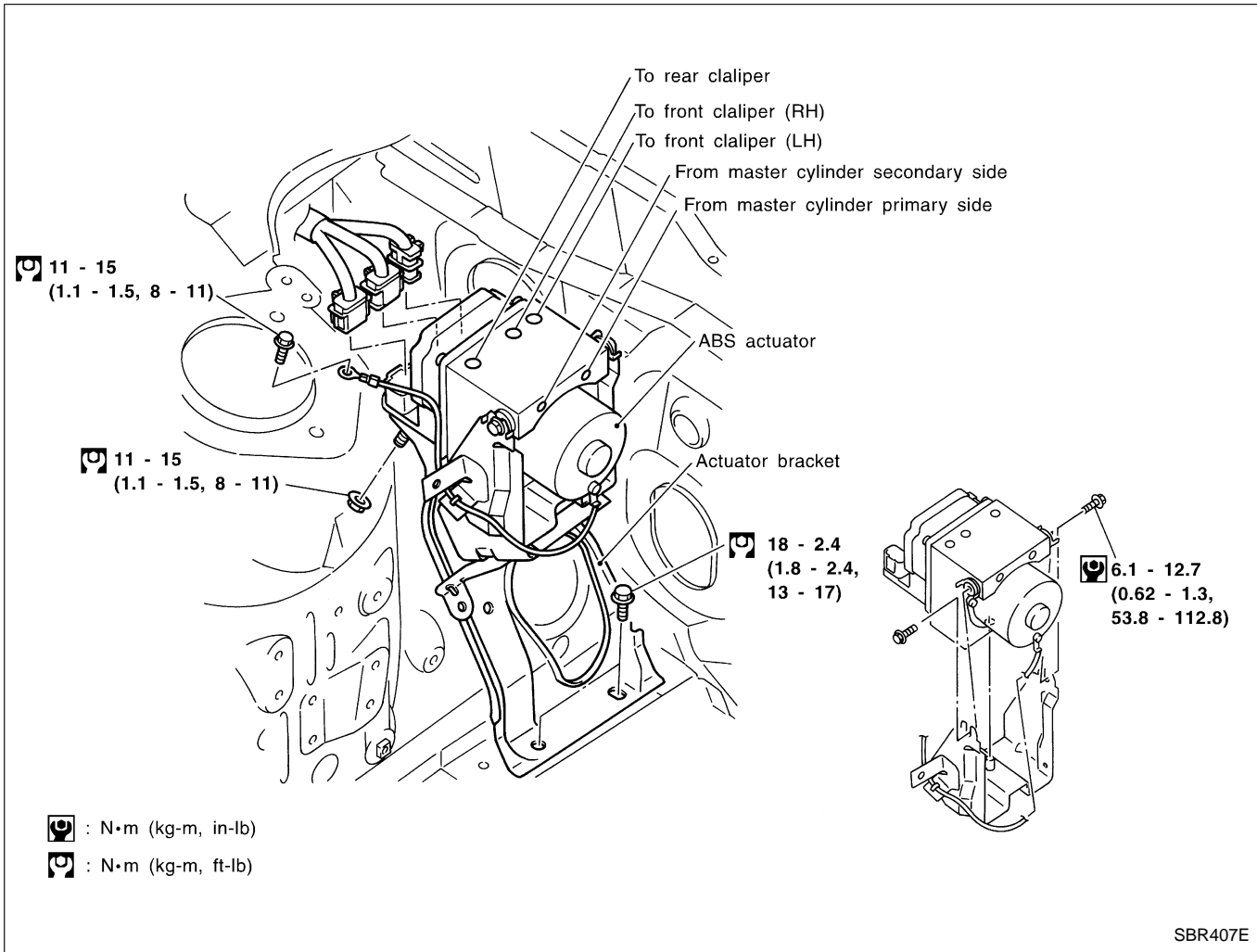

Removal

1. Disconnect battery cable.
2. Drain brake fluid. Refer to "Changing Brake Fluid", BR-6.
3. Apply different colored paint to each pipe connector and actuator to prevent incorrect connection.
4. Disconnect connector, brake pipes and remove fixing nuts and actuator ground cable.
5. Remove actuator.

GI
MA
EM
LC
EC
FE
AT
PD
FA
RA
BR
ST
RS
BT
HA
EL
IDX

Removal and Installation (Cont'd)

Installation

CAUTION:

After installing actuator, refill brake fluid. Then bleed air. Refer to “Bleeding Brake System”, BR-7.

1. Tighten actuator ground cable.

Place ground cable at a notch of mounting bracket.

2. Connect brake pipes temporarily.

3. Tighten fixing nuts.

4. Tighten brake pipes.

5. Connect connector and battery cable.

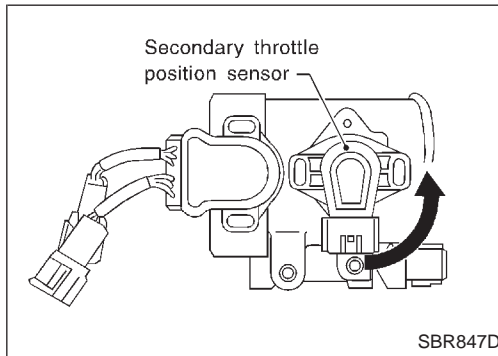

SECONDARY THROTTLE POSITION SENSOR

Removal

1. Remove collector ornament.

2. Disconnect harness connector and remove secondary throttle position sensor.

Installation

- Insert secondary throttle position sensor into shaft in the direction shown in the figure, rotate it counterclockwise and temporarily tighten mounting screws.

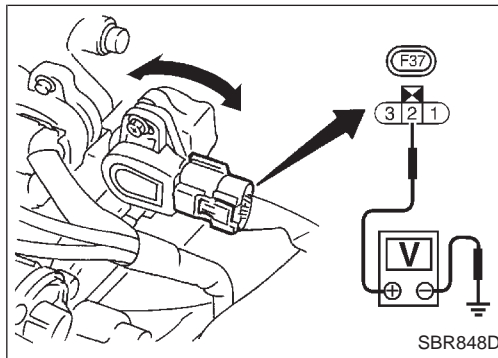

Adjustment

1. After tightening secondary throttle position sensor temporarily, connect harness connector and warm up the engine.

2. Turn ignition switch “ON” (engine stopped). Then adjust sensor position so that the sensor output voltage becomes 4.5 - 4.7V (between terminal ② of harness connector (F37) and ground).

3. Securely tighten sensor mounting screws.

4. Check the output voltage of secondary throttle position sensor again.

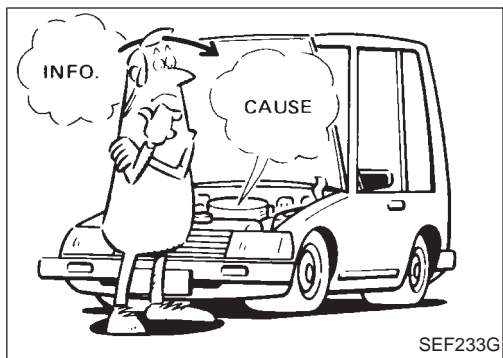

SEF233G

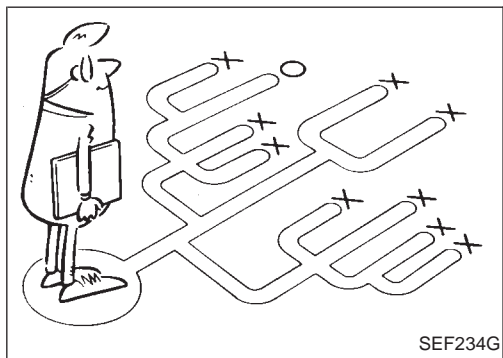

SEF234G

How to Perform Trouble Diagnoses for Quick and Accurate Repair

INTRODUCTION

The TCS has two electronic control units. One is called the TCS/ABS control unit. The ABS system has an electronic control unit to control major functions and for the ABS. The other is the throttle control module (TAC module) which is used to control the throttle opening. The control units accept input signals from sensors and instantly drive actuators. It is essential that both kinds of signals are proper and stable. Also there should be no such conventional problems as oil leaks in the TCS operating circuits. Nor should there be lack of brake fluid or other problems with the brake system.

It is much more difficult to diagnose a problem that occurs intermittently rather than continuously. Most intermittent problems are caused by poor electric connections or faulty wiring. In this case, careful checking of suspicious circuits may help prevent the replacement of good parts.

A visual check only may not find the cause of the problems, so a road test should be carried out.

Before undertaking actual checks, take just a few minutes to talk with a customer who approaches with a TCS complaint. The customer is a very good source of information on such problems; especially intermittent ones. Through the talks with the customer, find out what symptoms are present and under what conditions they occur.

Start your diagnosis by looking for "conventional" problems first. This is one of the best ways to troubleshoot brake problems on a TCS controlled vehicle. Also check related Service Bulletins for information.

It is strongly recommended that the TCS/ABS control unit be checked for electrical problems first. Then check the TAC module.

GI
MA
EM
LC
EC
FE
AT
PD
FA
RA
BR
ST
RS
BT
HA
EL
IDX

TROUBLE DIAGNOSES

How to Perform Trouble Diagnoses for Quick and Accurate Repair (Cont'd)

WORK FLOW

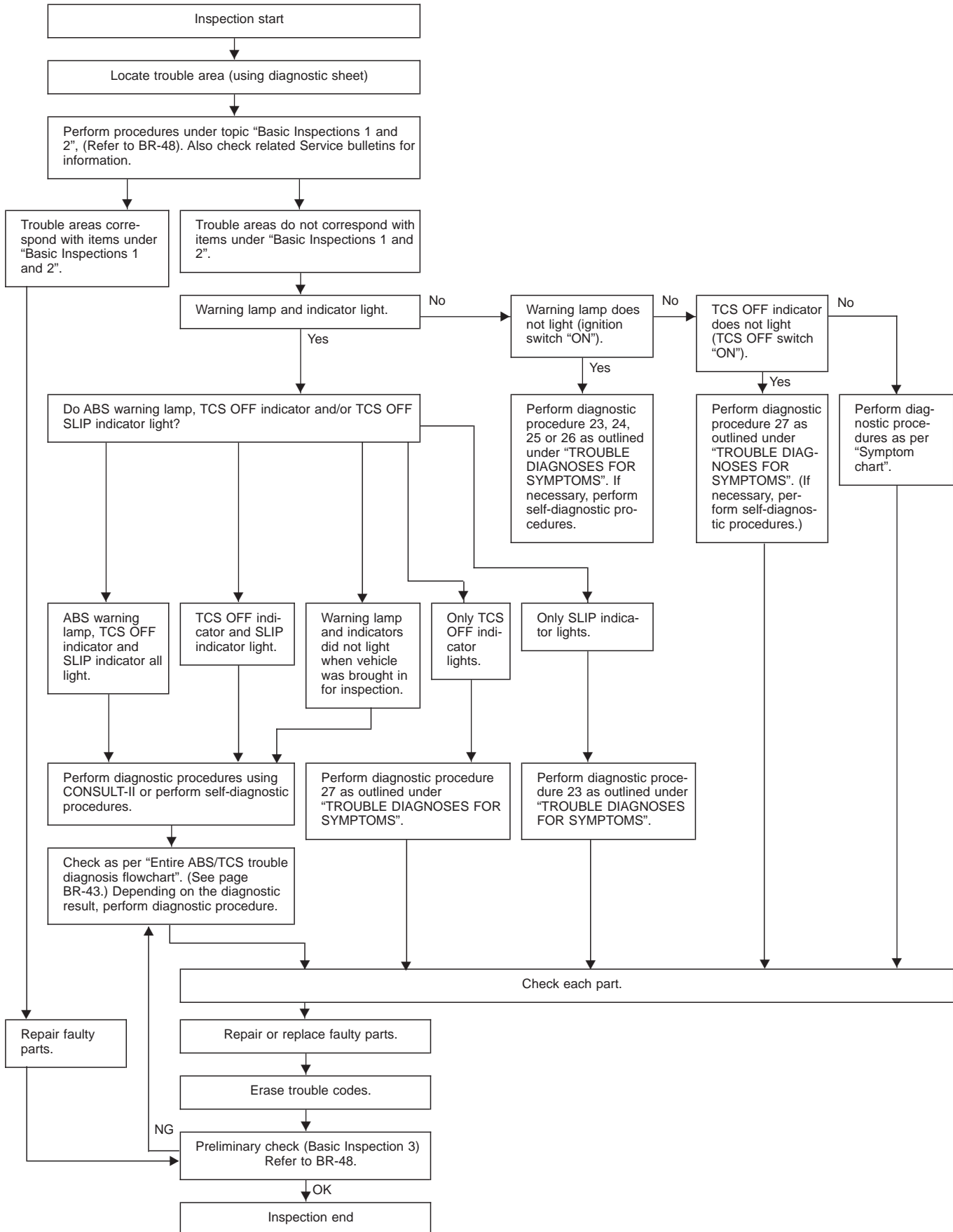

TROUBLE DIAGNOSES

How to Perform Trouble Diagnoses for Quick and Accurate Repair (Cont'd)

Entire ABS/TCS trouble diagnostic flowchart

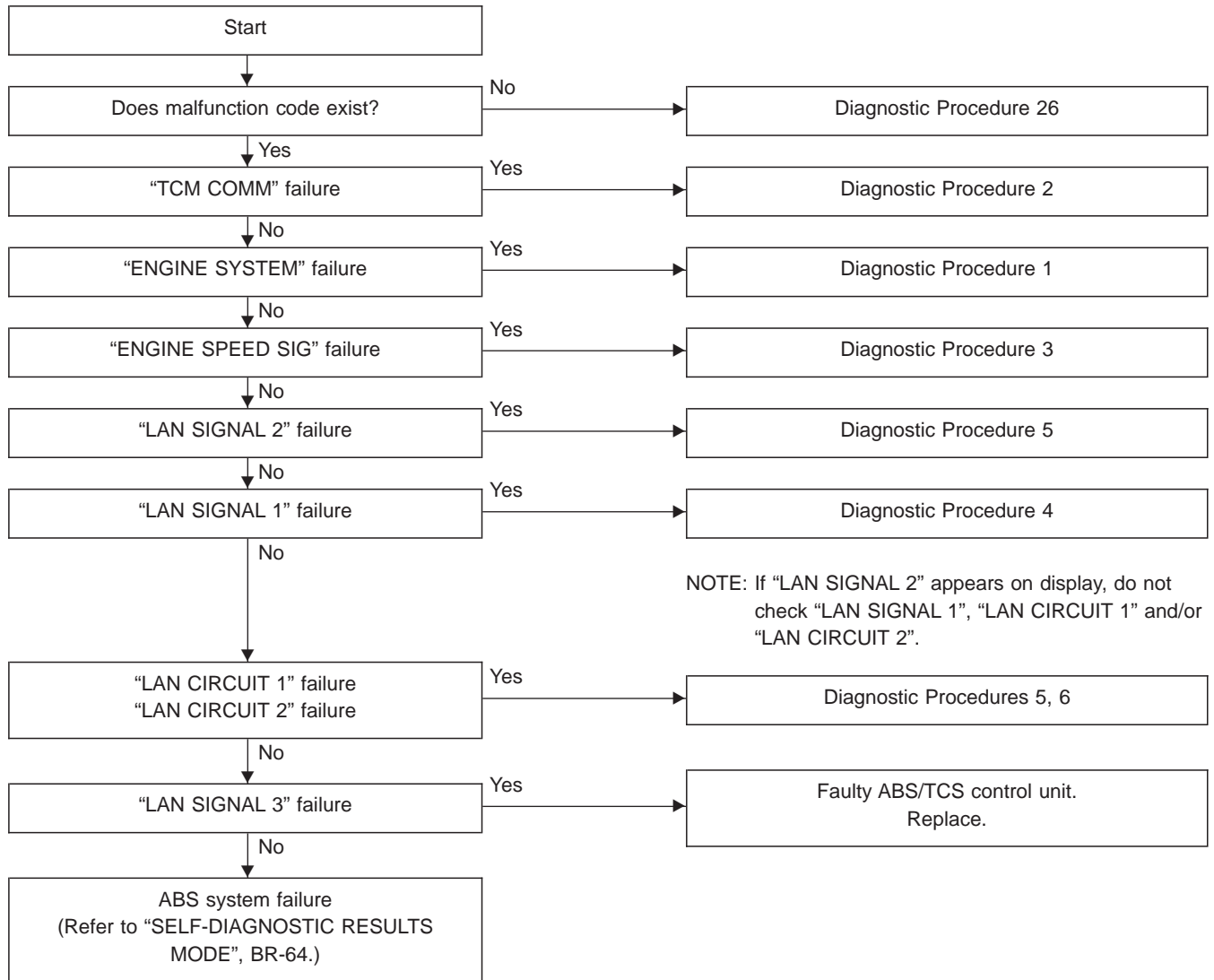

GI
MA
EM
LC
EC
FE
AT
PD
FA
RA
BR
ST
RS
BT
HA
EL
IDX

TROUBLE DIAGNOSES

How to Perform Trouble Diagnoses for Quick and Accurate Repair (Cont'd)

DIAGNOSTIC WORKSHEET

There are many kinds of operating conditions that lead to customer complaints, even if the system is normal.

A good grasp of such conditions can make troubleshooting faster and more accurate.

It is important to fully understand the symptoms or under what conditions a customer complains.

Make good use of a diagnostic worksheet as shown below in order to utilize all the complaints for troubleshooting.

KEY POINTS

- WHAT** Vehicle model
WHEN Date, Frequencies
WHERE Road conditions
HOW Operating conditions,
 Weather conditions,
 Symptoms

SBR339B

Worksheet sample

Customer name MR/MS	Model & Year	VIN	
Engine #	Trans.	Mileage	
Incident Date	Manuf. Date	In Service Date	
Symptoms	<input type="checkbox"/> Noise and vibration (from engine compartment)	<input type="checkbox"/> Warning/Indicator activate	<input type="checkbox"/> Firm pedal operation
	<input type="checkbox"/> Noise and vibration (from axle)		<input type="checkbox"/> Large stroke pedal operation
	<input type="checkbox"/> TCS does not work (Rear wheels slip when accelerating)	<input type="checkbox"/> ABS does not work. (wheels slip when braking)	<input type="checkbox"/> Lack of sense of acceleration
Engine conditions	<input type="checkbox"/> When starting <input type="checkbox"/> After starting		
Road conditions	<input type="checkbox"/> Low friction road (<input type="checkbox"/> Snow <input type="checkbox"/> Gravel <input type="checkbox"/> Other) <input type="checkbox"/> Bumps/potholes		
Driving conditions	<input type="checkbox"/> Full-acceleration <input type="checkbox"/> High speed cornering <input type="checkbox"/> Vehicle speed: Greater than 10 km/h (6 MPH) <input type="checkbox"/> Vehicle speed: 10 km/h (6 MPH) or less <input type="checkbox"/> Vehicle is stopped		
Applying brake conditions	<input type="checkbox"/> Suddenly <input type="checkbox"/> Gradually		
Other conditions	<input type="checkbox"/> Operation of electrical equipment <input type="checkbox"/> Shift change <input type="checkbox"/> Other descriptions		

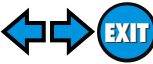

TROUBLE DIAGNOSES

Symptom Chart

SYMPTOM	PROCEDURE	Preliminary check			Diagnostic Procedures																	
					TROUBLE DIAGNOSES FOR SELF-DIAGNOSTIC ITEMS																	
		BASIC INSPECTION 1	BASIC INSPECTION 2	BASIC INSPECTION 3	Diagnostic Procedure 1	Diagnostic Procedure 2	Diagnostic Procedure 3	Diagnostic Procedure 4	Diagnostic Procedure 5	Diagnostic Procedure 6	Diagnostic Procedure 7	Diagnostic Procedure 8	Diagnostic Procedure 9	Diagnostic Procedure 10	Diagnostic Procedure 11	Diagnostic Procedure 12						
Long stopping distance		<input type="radio"/>	<input type="radio"/>	<input type="radio"/>																LC		
Poor acceleration		<input type="radio"/>	<input type="radio"/>	<input type="radio"/>																EC		
Abnormal indicator/warning lamp operation		<input type="radio"/>	<input type="radio"/>	<input type="radio"/>																FE		
TCS cannot be canceled by TCS OFF switch.		<input type="radio"/>	<input type="radio"/>	<input type="radio"/>																AT		
TAC module power and ground circuits		<input type="radio"/>	<input type="radio"/>	<input type="radio"/>																PD		
Warning activates, but self-diagnosis does not work.		<input type="radio"/>	<input type="radio"/>	<input type="radio"/>														<input type="radio"/>				
ABS works frequently.		<input type="radio"/>	<input type="radio"/>	<input type="radio"/>																		
Unexpected pedal action		<input type="radio"/>	<input type="radio"/>	<input type="radio"/>																		
ABS does not work.																						
Pedal vibration and noise																						
SELF-DIAGNOSTIC RESULT	ABS/TCS control unit	Code No. 21, 22, 25, 26, 31, 32, 35, 36	<input type="radio"/>	<input type="radio"/>	<input type="radio"/>							<input type="radio"/>								FA		
		Code No. 41, 42, 45, 46, 55, 56	<input type="radio"/>	<input type="radio"/>	<input type="radio"/>									<input type="radio"/>							RA	
		Code No. 63	<input type="radio"/>	<input type="radio"/>	<input type="radio"/>										<input type="radio"/>						BR	
		Code No. 61	<input type="radio"/>	<input type="radio"/>	<input type="radio"/>											<input type="radio"/>					ST	
		Code No. 57	<input type="radio"/>	<input type="radio"/>	<input type="radio"/>												<input type="radio"/>				RS	
		Code No. 71	<input type="radio"/>	<input type="radio"/>	<input type="radio"/>													<input type="radio"/>				BT
		No code indication (OFF)	<input type="radio"/>	<input type="radio"/>	<input type="radio"/>																	HA
		No code indication (ON)	<input type="radio"/>	<input type="radio"/>	<input type="radio"/>																	EL
		Code No. 80	<input type="radio"/>	<input type="radio"/>	<input type="radio"/>			<input type="radio"/>														IDX
		Code No. 58	<input type="radio"/>	<input type="radio"/>	<input type="radio"/>		<input type="radio"/>															
	Code No. 83	<input type="radio"/>	<input type="radio"/>	<input type="radio"/>				<input type="radio"/>														
	Code No. 85	<input type="radio"/>	<input type="radio"/>	<input type="radio"/>					<input type="radio"/>													
	Code No. 75	<input type="radio"/>	<input type="radio"/>	<input type="radio"/>						<input type="radio"/>												
	Code No. 84	<input type="radio"/>	<input type="radio"/>	<input type="radio"/>	<input type="radio"/>																	
	Code No. 11	<input type="radio"/>	<input type="radio"/>	<input type="radio"/>																		
	Code No. 12	<input type="radio"/>	<input type="radio"/>	<input type="radio"/>																		
	Code No. 13	<input type="radio"/>	<input type="radio"/>	<input type="radio"/>																		
	Code No. 21	<input type="radio"/>	<input type="radio"/>	<input type="radio"/>																		
	Code No. 22	<input type="radio"/>	<input type="radio"/>	<input type="radio"/>																		
	Code No. 23, 24	<input type="radio"/>	<input type="radio"/>	<input type="radio"/>																		
Code No. 31	<input type="radio"/>	<input type="radio"/>	<input type="radio"/>																			
Code No. 32	<input type="radio"/>	<input type="radio"/>	<input type="radio"/>																			
Code No. 33	<input type="radio"/>	<input type="radio"/>	<input type="radio"/>																			
Code No. 34	<input type="radio"/>	<input type="radio"/>	<input type="radio"/>																			

TROUBLE DIAGNOSES

Symptom Chart (Cont'd)

SYMPTOM		Diagnostic Procedures																			
		TROUBLE DIAGNOSES FOR SELF-DIAGNOSTIC ITEMS										TROUBLE DIAGNOSES FOR SYMPTOMS									
		13	14	15	16	17	18	19	20	21	22	23	24	25	26	27	28	29	30	31	32
Long stopping distance																					
Poor acceleration																					
Abnormal indicator/warning lamp operation																					
TCS cannot be canceled by TCS OFF switch.																					
TAC module power and ground circuits		○																			
Warning activates, but self-diagnosis does not work.																					
ABS works frequently.																					
Unexpected pedal action																					
ABS does not work.																					
Pedal vibration and noise																					
SELF-DIAGNOSTIC RESULT	ABS/TCS control unit	Code No. 21, 22, 25, 26, 31, 32, 35, 36																			
		Code No. 41, 42, 45, 46, 55, 56																			
		Code No. 63																			
		Code No. 61																			
		Code No. 57																			
		Code No. 71																			
		No code indication (OFF)																			
		No code indication (ON)																			
		Code No. 80																			
		Code No. 58																			
	Code No. 83																				
	Code No. 85																				
	Code No. 75																				
	Code No. 84																				
	TAC module	Code No. 11																			
		Code No. 12																			
		Code No. 13																			
		Code No. 21																			
		Code No. 22																			
		Code No. 23, 24																			
Code No. 31																					
Code No. 32																					
Code No. 33																					
Code No. 34																					

TROUBLE DIAGNOSES

Symptom Chart (Cont'd)

PROCEDURE		Electrical Component Inspection				
		TCS OFF SWITCH	THROTTLE MOTOR RELAY	PARK/NEUTRAL POSITION RELAY	PNP SWITCH	THROTTLE MOTOR
SYMPTOM						
	Long stopping distance					
	Poor acceleration					
	Abnormal indicator/warning lamp operation	○				
	TCS cannot be canceled by TCS OFF switch.	○				
	TAC module power and ground circuits					
	Warning activates, but self-diagnosis does not work.					
	ABS works frequently.					
	Unexpected pedal action					
	ABS does not work.					
	Pedal vibration and noise					
SELF-DIAGNOSTIC RESULT	ABS/TCS control unit	Code No. 21, 22, 25, 26, 31, 32, 35, 36				
		Code No. 41, 42, 45, 46, 55, 56				
		Code No. 63				
		Code No. 61				○
		Code No. 57				
		Code No. 71				
		No code indication (OFF)				
		No code indication (ON)				
		Code No. 80				
		Code No. 58				
		Code No. 83				
		Code No. 85				
		Code No. 75				
		Code No. 84				
	TAC module	Code No. 11				
		Code No. 12				
		Code No. 13				
		Code No. 21				
		Code No. 22				
		Code No. 23, 24		○		
Code No. 31						
Code No. 32						
Code No. 33			○	○		
Code No. 34						

GI
 MA
 EM
 LC
 EC
 FE
 AT
 PD
 FA
 RA
BR
 ST
 RS
 BT
 HA
 EL
 IDX

Preliminary Check (Check brake fluid level in reservoir tank and brake line for leakage.)

BASIC INSPECTION 1: BRAKE FLUID LEVEL AND LEAKAGE

1. Check brake fluid level in reservoir tank. Replenish brake fluid if necessary.
2. Check for leakage at or around brake piping and ABS actuators. If leakage or seepage is noted, proceed as follows:
 - If ABS actuator connectors are loose, tighten to specified torque. Recheck to ensure that leakage is no longer present.
 - If flare nut threads at piping connectors or actuator threads are damaged, replace faulty parts with new ones. Recheck to ensure that leakage is no longer present.
 - If brake fluid leaks through areas other than actuator connectors, wipe off using a clean cloth. Recheck for leakage or seepage. If necessary, replace faulty parts with new ones.
 - If brake fluid leaks at or seeps through actuators, wipe off using a clean cloth. Recheck for leakage or seepage. If necessary, replace with new actuators.

CAUTION:

ABS actuators cannot be disassembled.

3. Check brake booster for proper operation.
4. Check brake disc rotor and pad condition.

BASIC INSPECTION 2: LOOSE POWER LINE TERMINAL AND POWER VOLTAGE

Check battery terminals (positive and negative) and battery mounting (ground) for looseness. If necessary, tighten to specified torque. Also check for low battery voltage.

BASIC INSPECTION 3: SLIP, TCS OFF INDICATOR AND ABS WARNING LAMP

1. Turn ignition switch "ON" to ensure that TCS OFF indicator lights. If TCS OFF indicator does not light, check TCS OFF circuit.
(Refer to diagnostic procedure 24 "TCS OFF indicator does not come on when ignition switch is turned on" under "TROUBLE DIAGNOSES FOR SYMPTOMS".)
2. Turn ignition switch "ON" to ensure that SLIP indicator lights. If SLIP indicator does not light, check SLIP indicator circuit.
(Refer to diagnostic procedure 23 "SLIP indicator does not come on when ignition switch is turned on" under "TROUBLE DIAGNOSES FOR SYMPTOM".)
3. Turn ignition switch "ON" to ensure that ABS warning lamp lights. If ABS warning lamp does not light, check ABS warning lamp circuit.
(Refer to diagnostic procedure 25 "ABS warning lamp does not come on when ignition switch is turned on" under "TROUBLE DIAGNOSES FOR SYMPTOM".)
4. Check to ensure that SLIP indicator and ABS warning lamp go out approximately 1 second after engine starts. If SLIP indicator and ABS warning lamp do not go out, perform self-diagnostic procedures.
(Refer to BR-59, BR-63.)
5. After driving vehicle at 30 km/h (19 MPH) for more than 1 minute, check to ensure that SLIP indicator and ABS warning lamp remain off. If SLIP indicator and ABS warning lamp light, perform self-diagnostic procedures.
(Refer to BR-59, BR-63.)
6. While running engine, turn TCS OFF switch "ON" and "OFF" to ensure that TCS OFF indicator lights and goes out correspondingly. If TCS OFF indicator does not correspond with switch operation, check TCS OFF switch circuit.
(Refer to Diagnostic Procedure 27 "INOPERATIVE TCS OFF SWITCH" under "TROUBLE DIAGNOSES FOR SYMPTOM".)
7. Start engine (TCS OFF switch "OFF") to ensure that TCS OFF indicator goes out. If TCS OFF indicator remains on for more than 10 seconds after engine starts, perform self-diagnostic procedures.
(Refer to BR-59, BR-63.)
8. Drive vehicle at 30 km/h (19 MPH) for more than 1 minute to ensure that TCS OFF indicator remains off. If TCS OFF indicator lights, perform self-diagnostic procedures.
(Refer to BR-59, BR-63.)
9. After performing self-diagnostic procedures, be sure to erase trouble stored in memory.

TROUBLE DIAGNOSES

Component Parts and Harness Connector Location

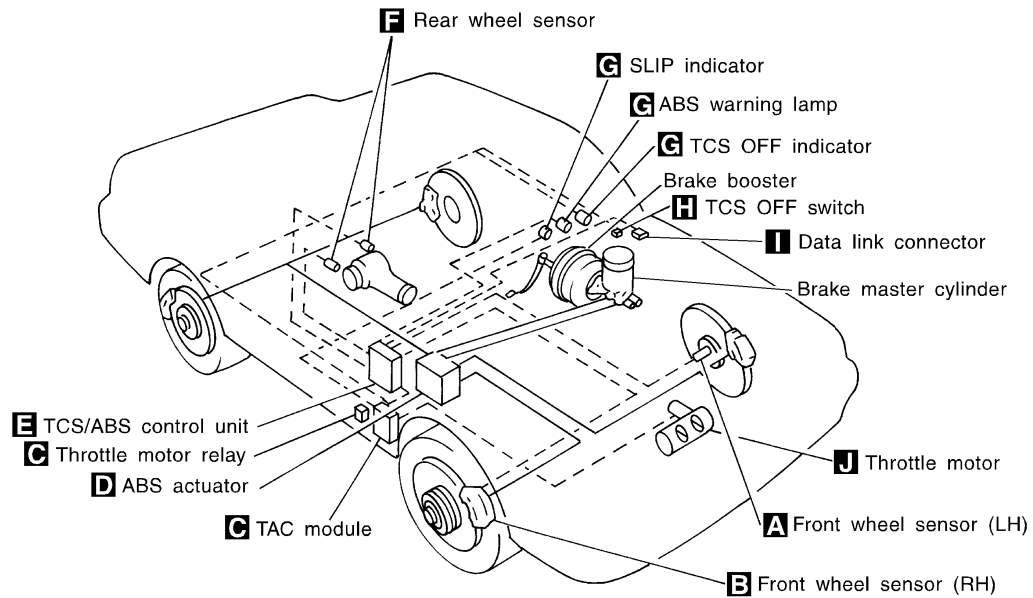

GI
MA
EM
LC
EC
FE
AT
PD
FA
RA
BR
ST
RS
BT
HA
EL
IDX

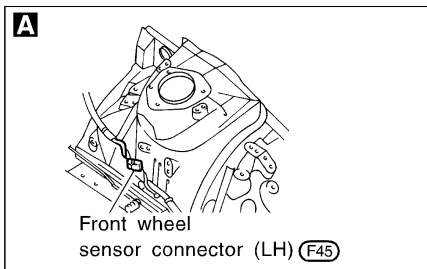

—— : Harness
- - - : Piping

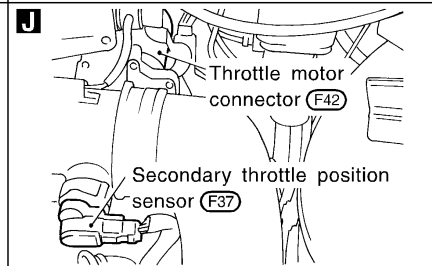
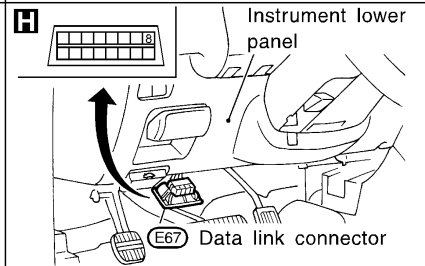
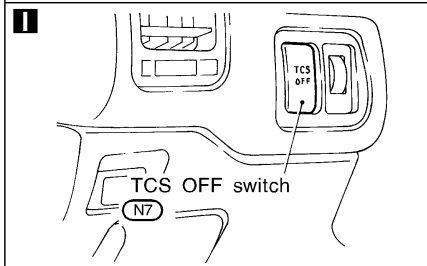
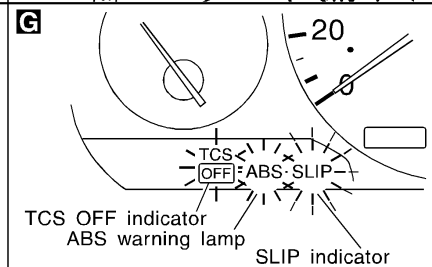
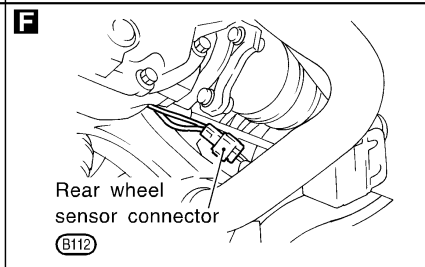
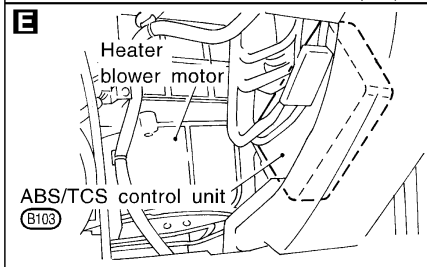
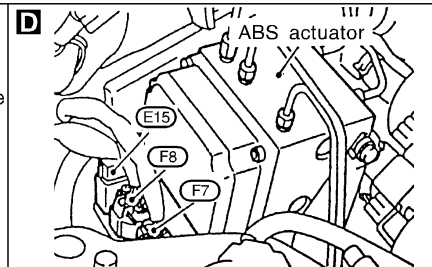
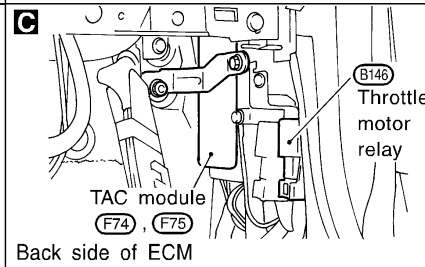
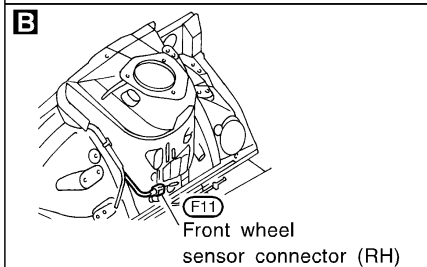

Schematic

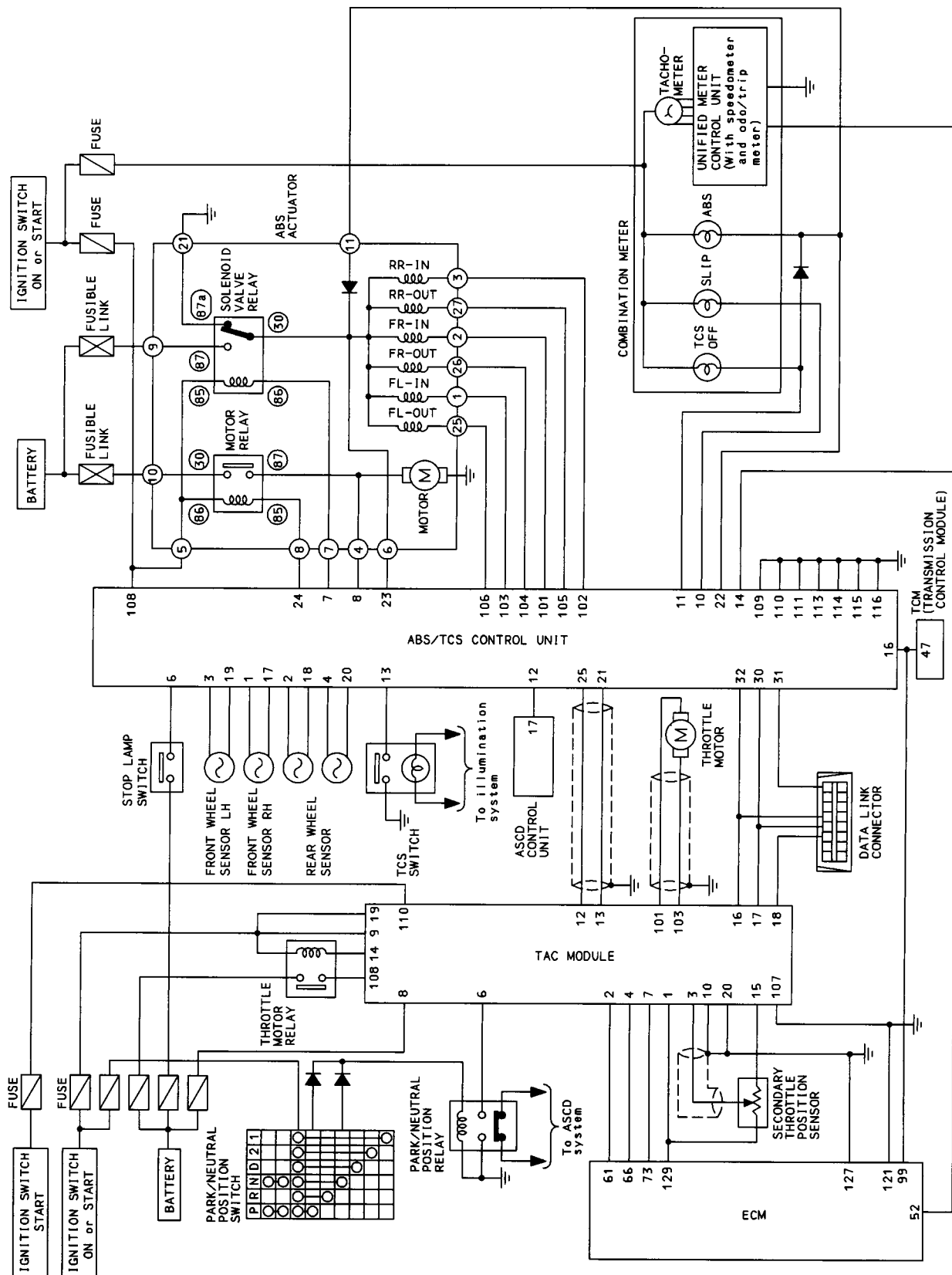

TROUBLE DIAGNOSES

Wiring Diagram — TCS —

BR-TCS-01

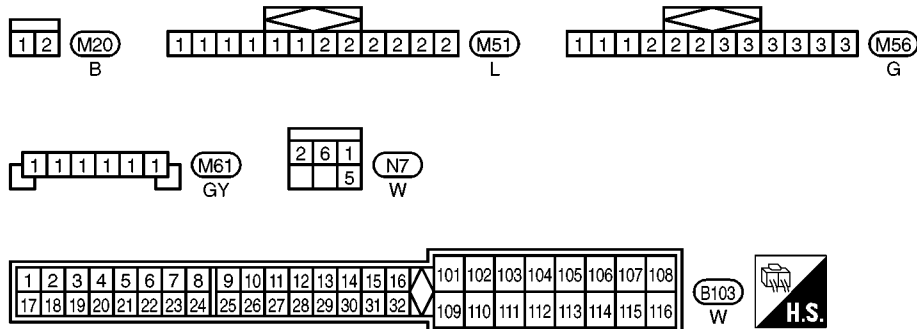
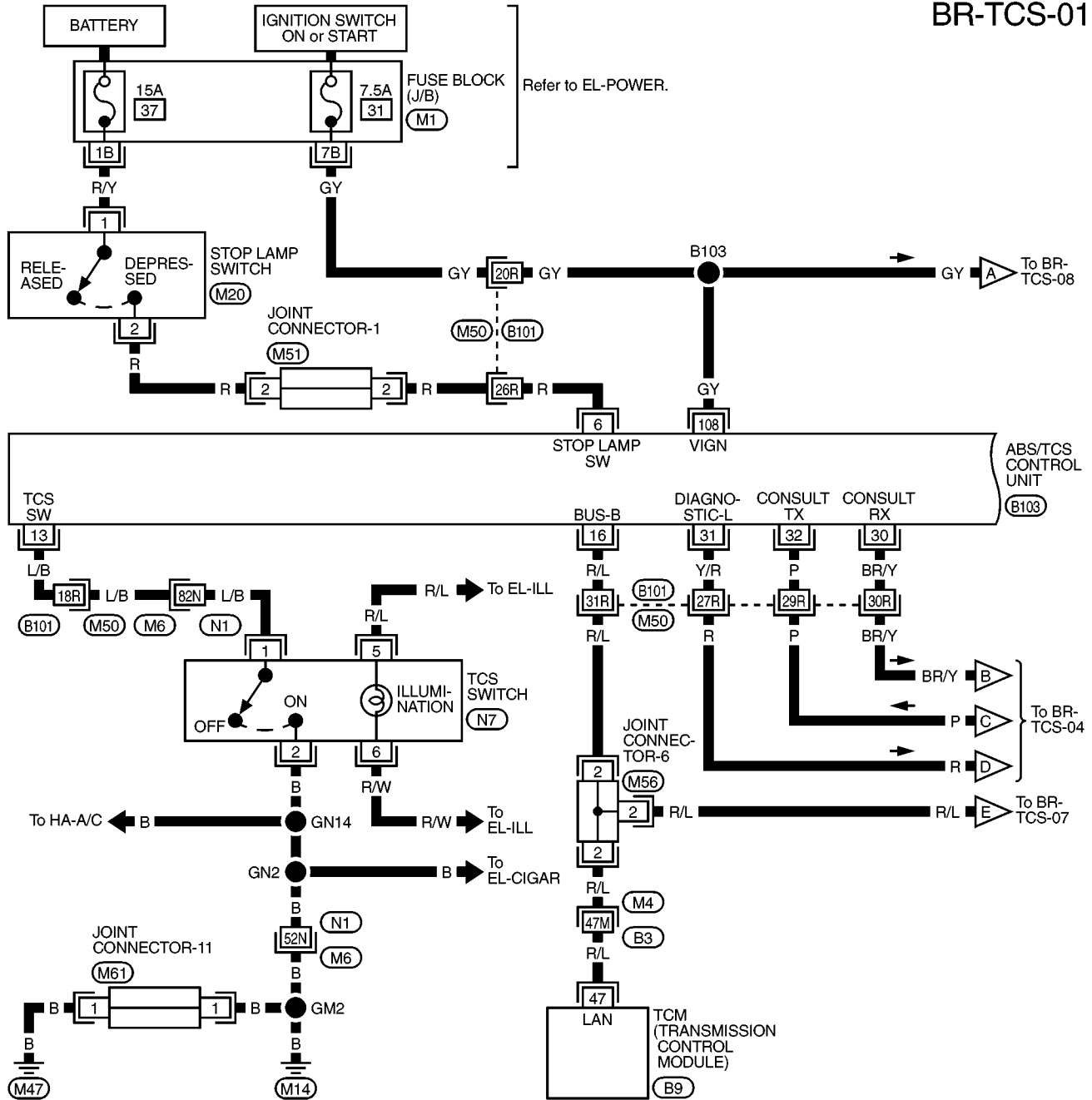

REFER TO THE FOLLOWING.
 (M4), (M6), (M50) -SUPER
 MULTIPLE JUNCTION (SMJ)
 (M1) -FUSE BLOCK-JUNCTION
 BOX (J/B)
 (B9) -ELECTRICAL UNITS

GI
 MA
 EM
 LC
 EC
 FE
 AT
 PD
 FA
 RA
BR
 ST
 RS
 BT
 HA
 EL
 IDX

TROUBLE DIAGNOSES

Wiring Diagram — TCS — (Cont'd)

BR-TCS-02

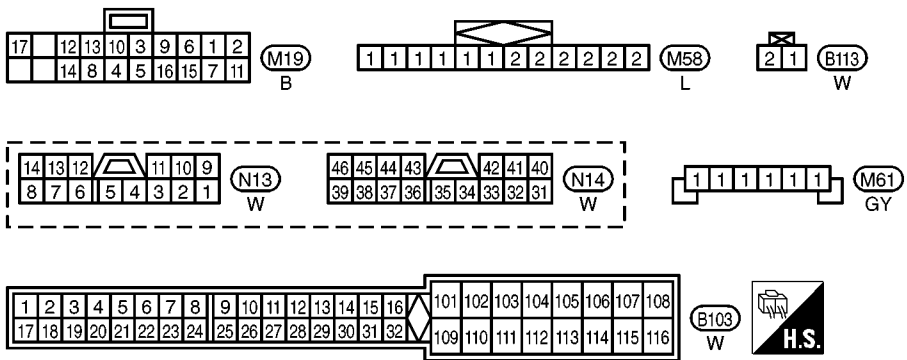
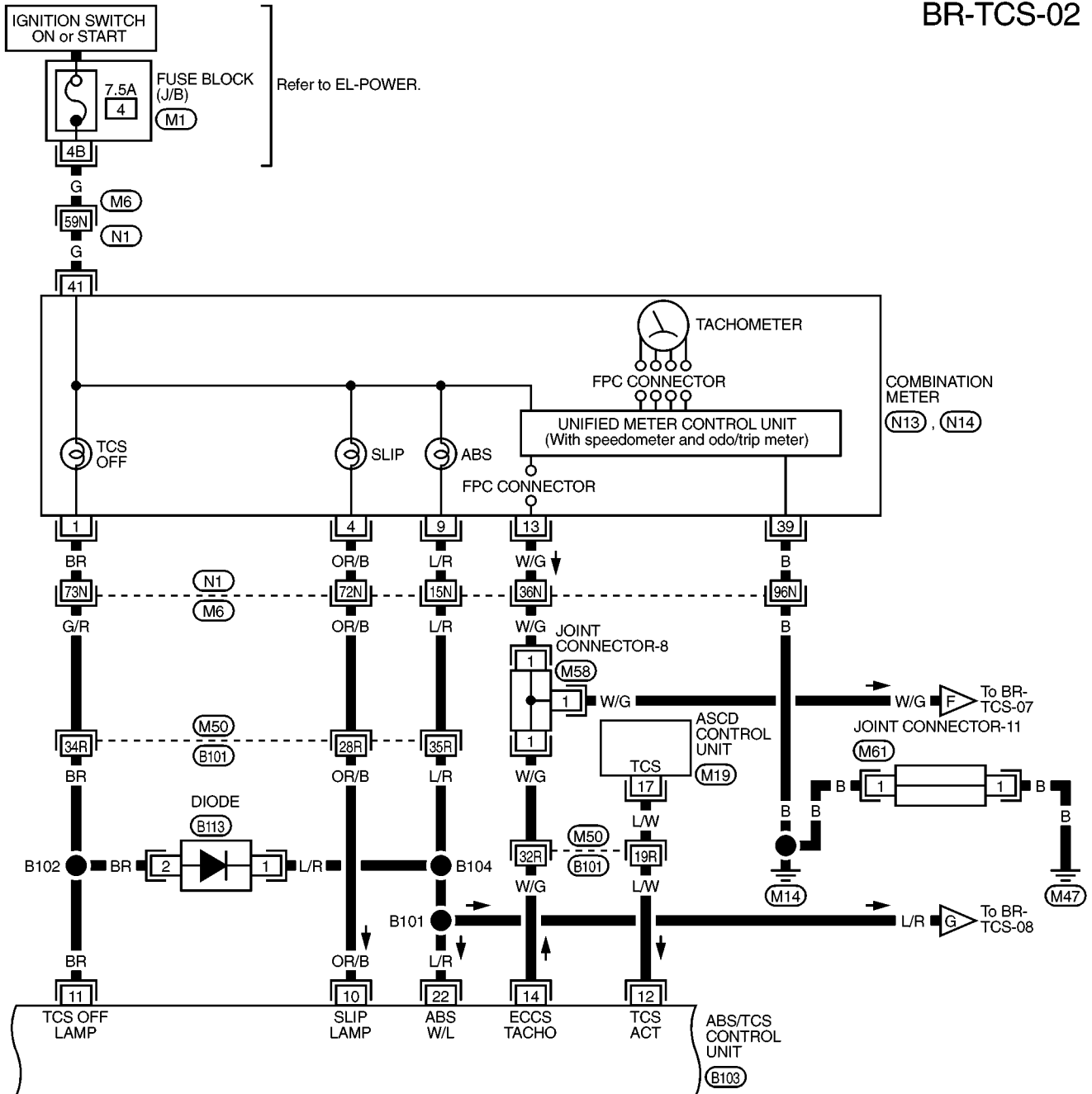

REFER TO THE FOLLOWING.
 (M6), (M50) -SUPER MULTIPLE JUNCTION (SMJ)
 (M1) -FUSE BLOCK-JUNCTION BOX (J/B)

TROUBLE DIAGNOSES

Wiring Diagram — TCS — (Cont'd)

BR-TCS-03

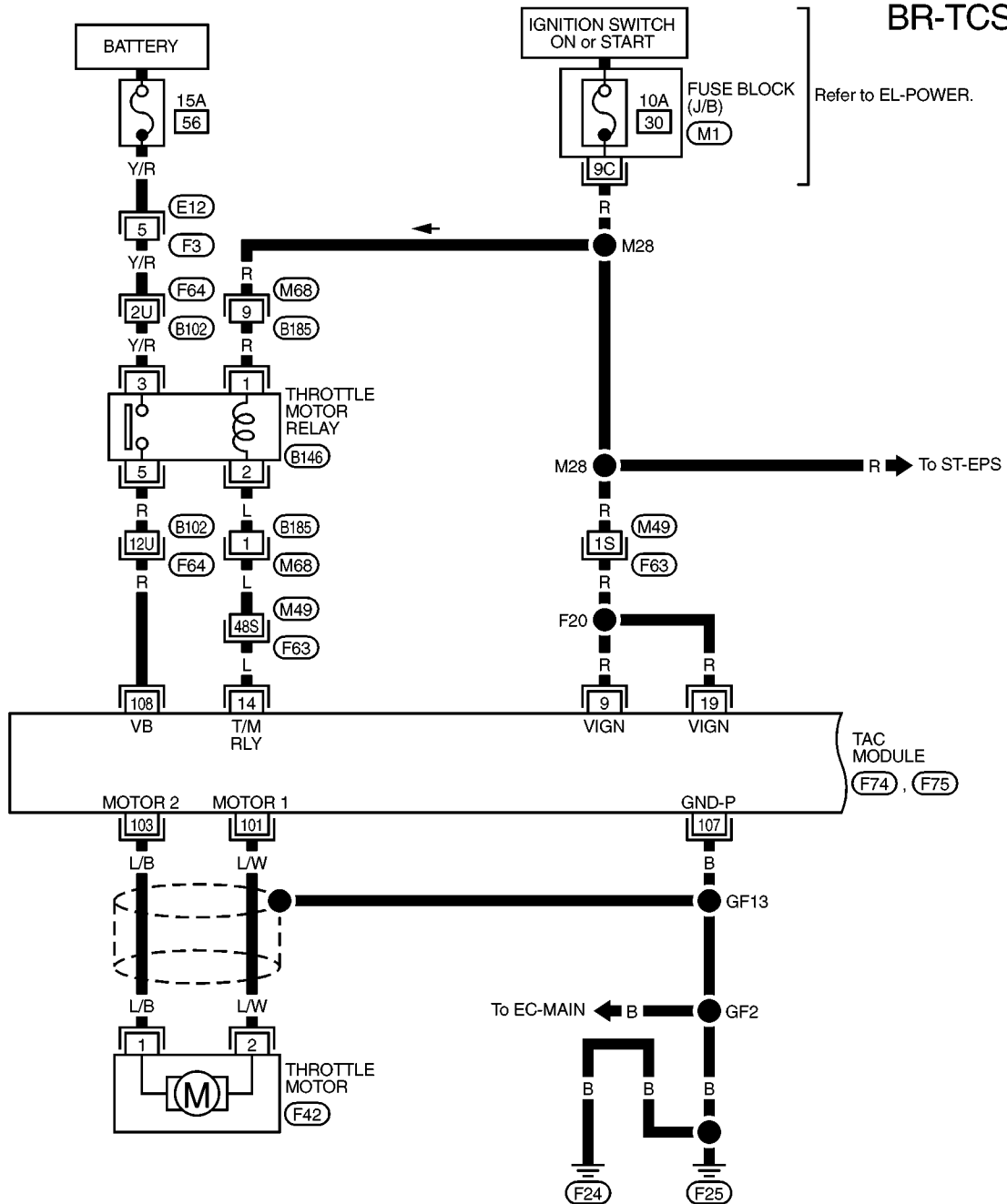

GI
MA
EM
LC
EC
FE
AT
PD
FA
RA
BR
ST
RS
BT
HA
EL
IDX

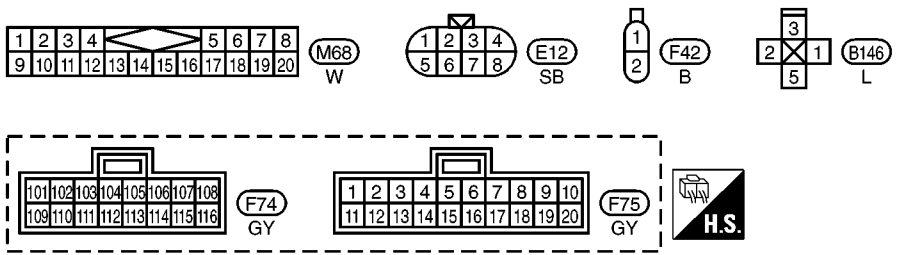

REFER TO THE FOLLOWING.
 (F63), (F64) -SUPER MULTIPLE JUNCTION (SMJ)
 (M1) -FUSE BLOCK-JUNCTION BOX (J/B)

TROUBLE DIAGNOSES

Wiring Diagram — TCS — (Cont'd)

BR-TCS-04

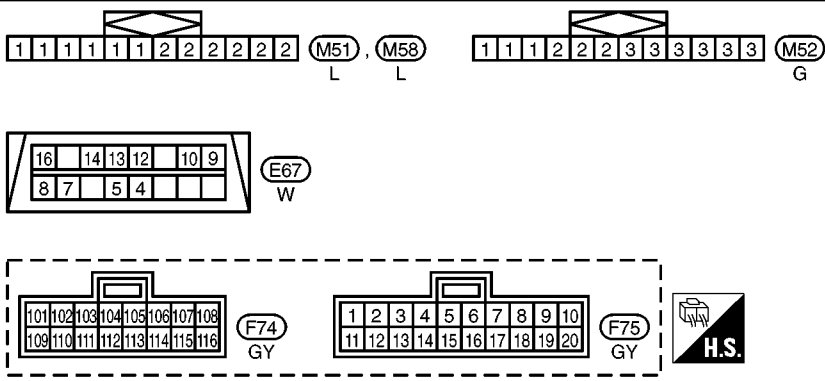
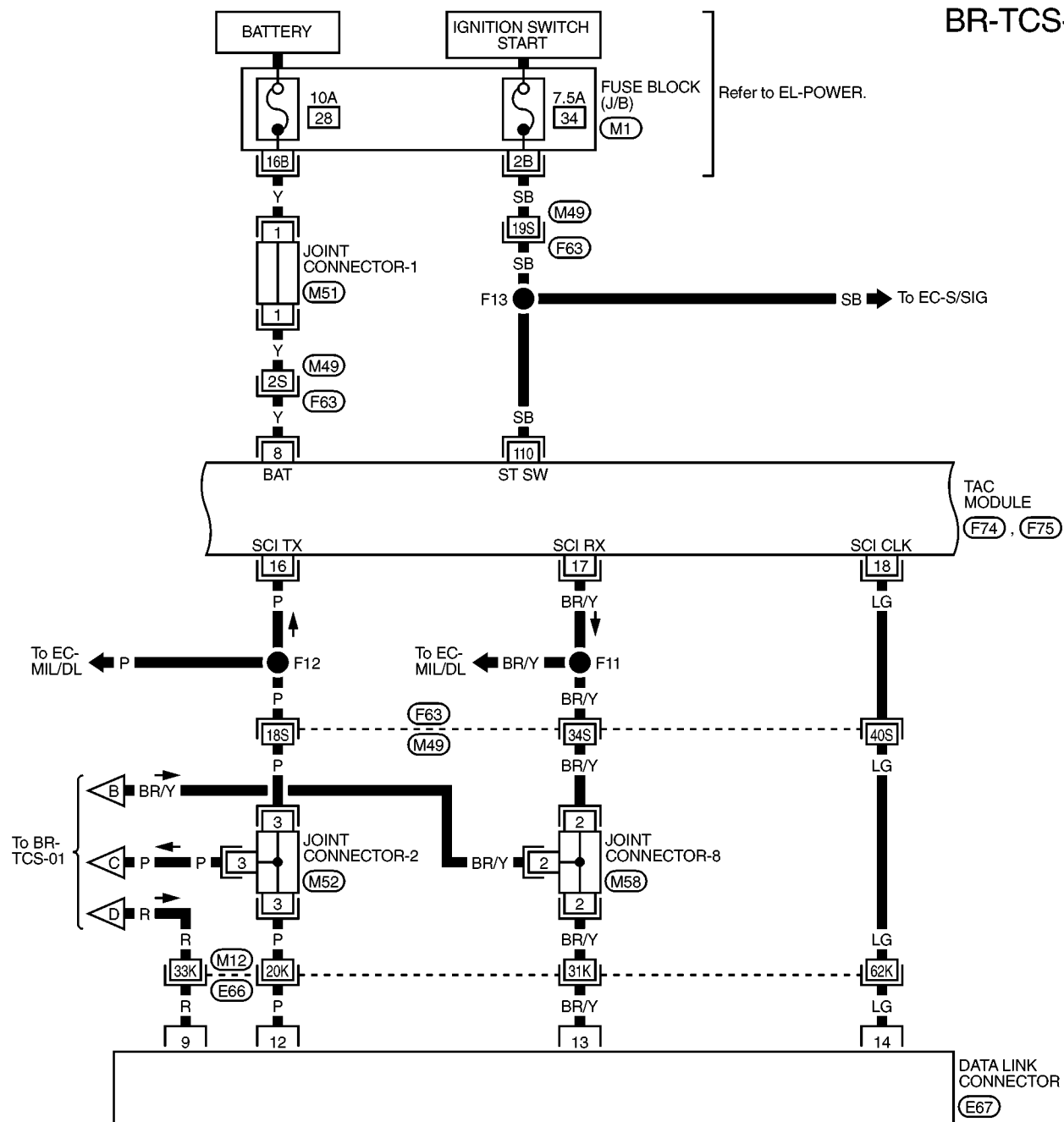

REFER TO THE FOLLOWING.
 (E66), (F63) -SUPER MULTIPLE JUNCTION (SMJ)
 (M1) -FUSE BLOCK-JUNCTION BOX (J/B)

TROUBLE DIAGNOSES

Wiring Diagram — TCS — (Cont'd)

BR-TCS-05

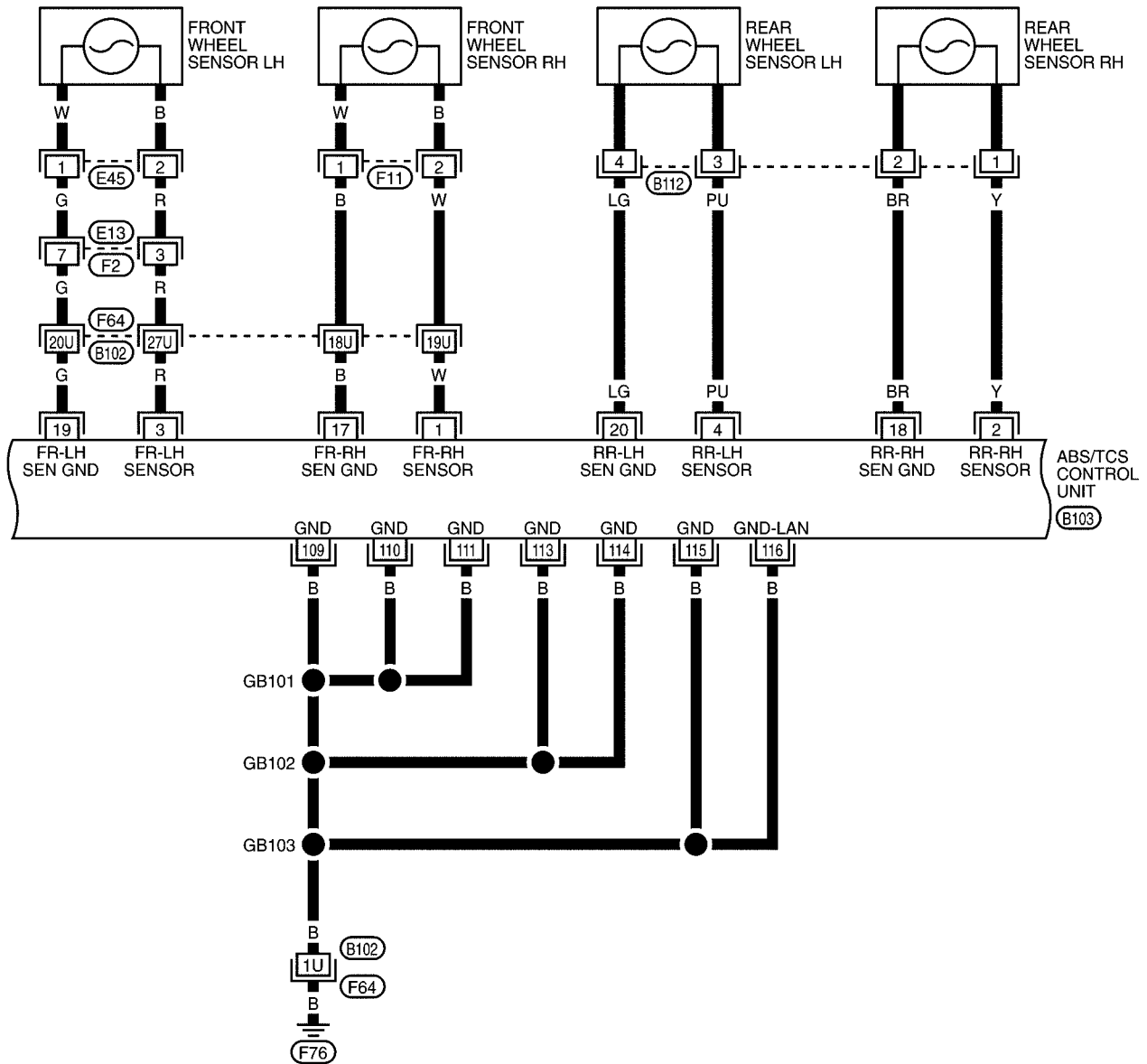

GI
MA
EM
LC
EC
FE
AT
PD
FA
RA
BR
ST
RS
BT
HA
EL
IDX

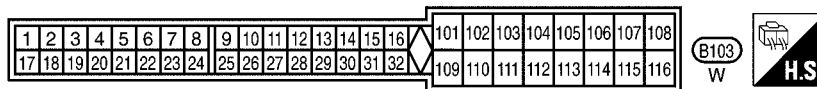

REFER TO THE FOLLOWING.
(F64) -SUPER MULTIPLE JUNCTION (SMJ)

TROUBLE DIAGNOSES

Wiring Diagram — TCS — (Cont'd)

BR-TCS-06

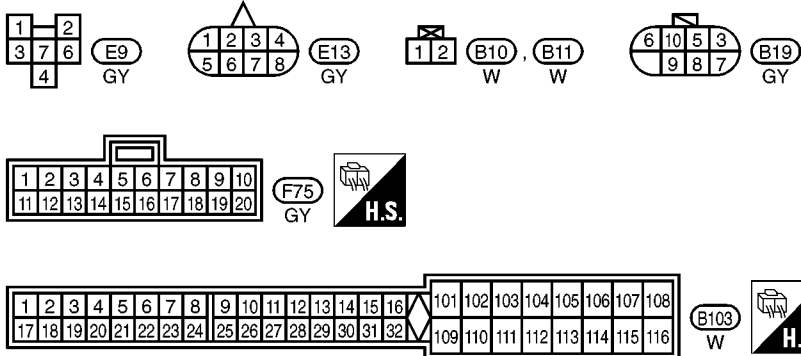
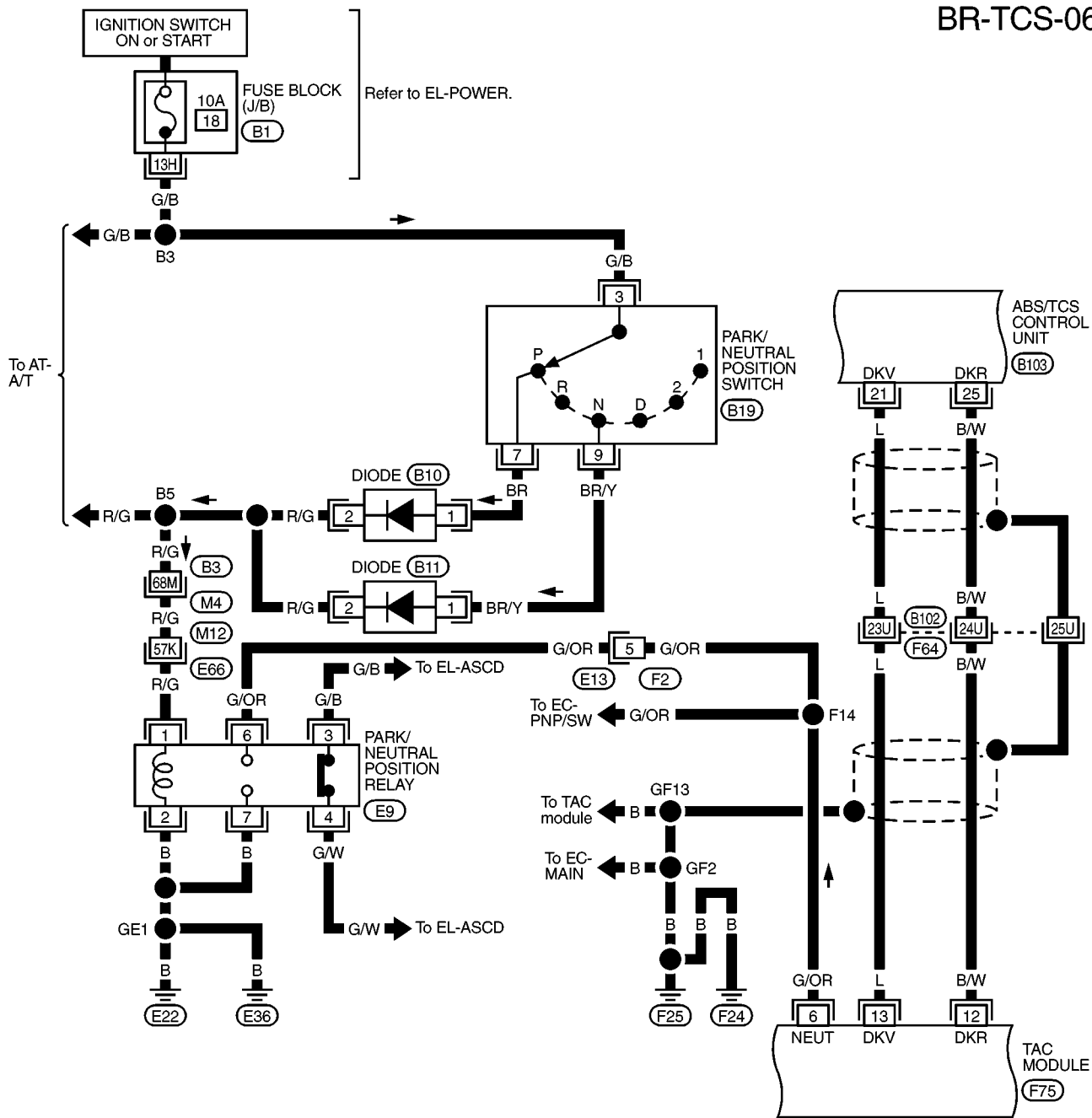

REFER TO THE FOLLOWING.
 (M4), (E66), (F64) -SUPER
 MULTIPLE JUNCTION (SMJ)
 (B1) -FUSE BLOCK-JUNCTION
 BOX (J/B)

TROUBLE DIAGNOSES

Wiring Diagram — TCS — (Cont'd)

BR-TCS-07

GI
MA
EM
LC
EC
FE
AT
PD
FA
RA
BR
ST
RS
BT
HA
EL
IDX

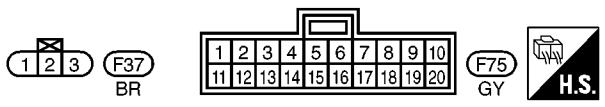
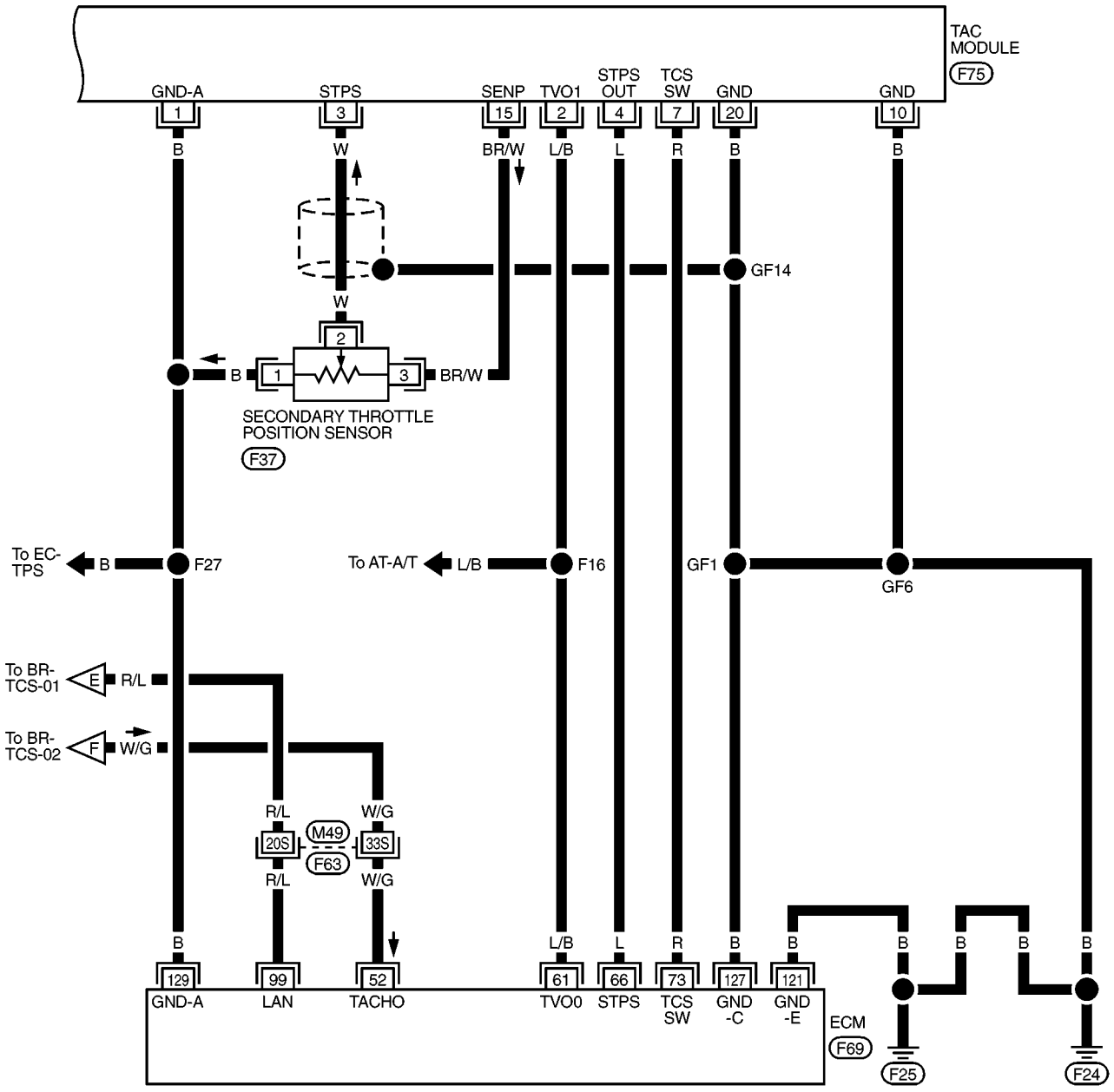

REFER TO THE FOLLOWING.
 (F63) -SUPER MULTIPLE JUNCTION (SMJ)
 (F69) -ELECTRICAL UNITS

TROUBLE DIAGNOSES

Wiring Diagram — TCS — (Cont'd)

BR-TCS-08

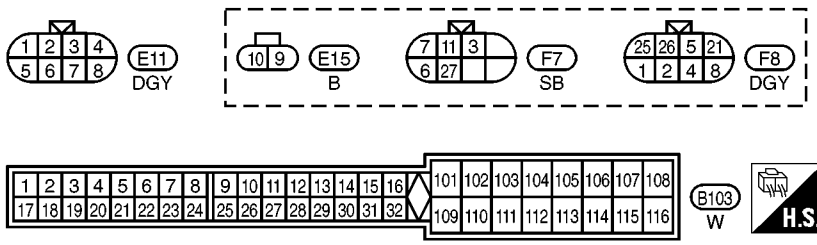
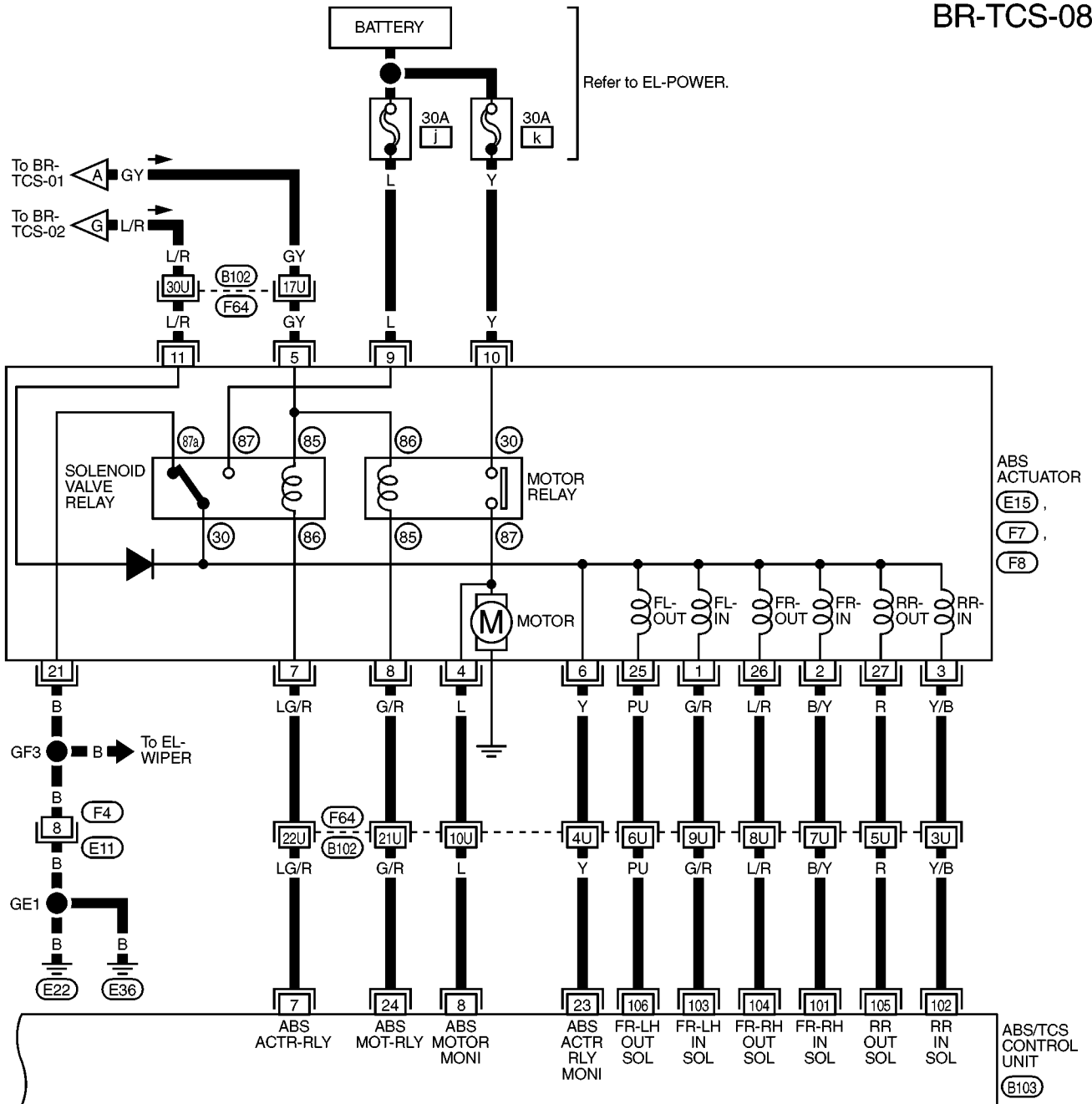

REFER TO THE FOLLOWING.
F64 -SUPER MULTIPLE JUNCTION (SMJ)

Self-diagnosis for ABS/TCS Control Unit

FUNCTION

- When a problem occurs in the ABS, the SLIP indicator on the instrument panel comes on. To start the self-diagnostic results mode, ground the self-diagnostic (check) terminal located on "Data Link Connector". The location of the malfunction is indicated by the SLIP indicator flashing.

GI

MA

EM

LC

EC

FE

AT

PD

FA

RA

BR

ST

RS

BT

HA

EL

IDX

SELF-DIAGNOSIS PROCEDURE

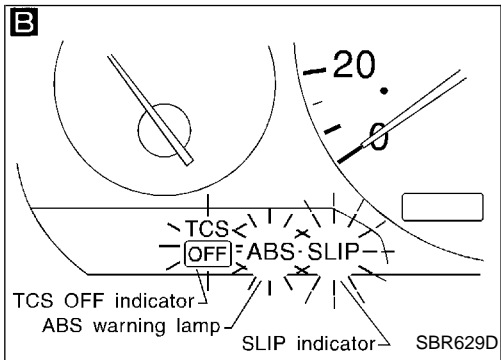
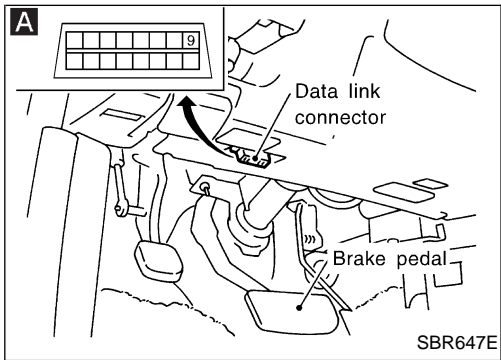
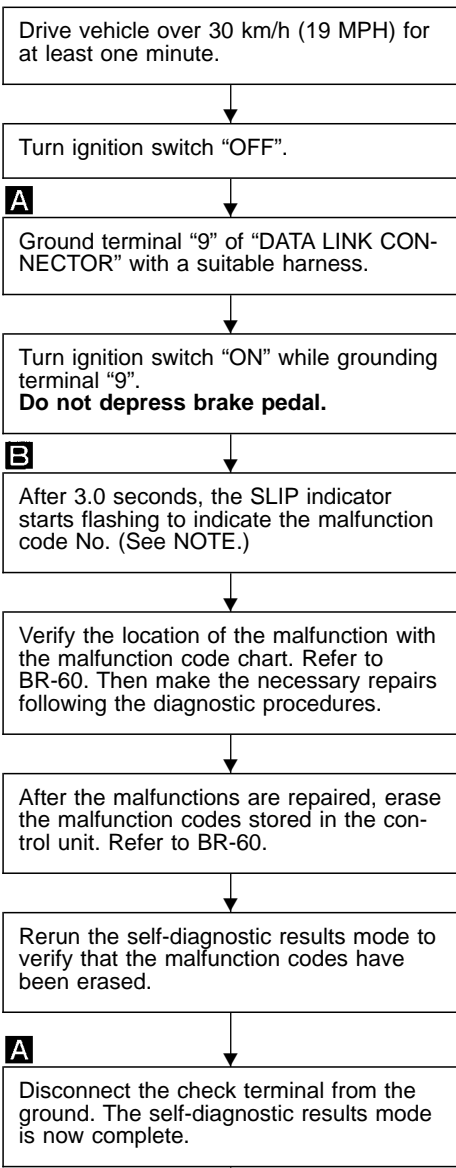

NOTE: The indication terminates after five minutes. However, when the ignition switch is turned from "OFF" to "ON", the indication starts flashing again. The TCS OFF indicator and ABS warning lamp remain lighted.

TROUBLE DIAGNOSES

Self-diagnosis for ABS/TCS Control Unit (Cont'd)

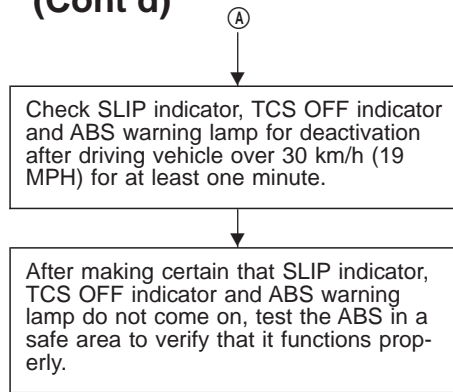

HOW TO READ SELF-DIAGNOSTIC RESULTS (Malfunction codes)

- Determine the code No. by counting the number of times the SLIP indicator flashes on and off.
- When several malfunctions occur at one time, up to three code numbers can be stored; the latest malfunction will be indicated first.
- The indication begins with the start code 12. After that a maximum of three code numbers appear in the order of the latest one first. The indication then returns to the start code 12 to repeat (the indication will stay on for five minutes at the most).
- The malfunction code chart is given on the next page.

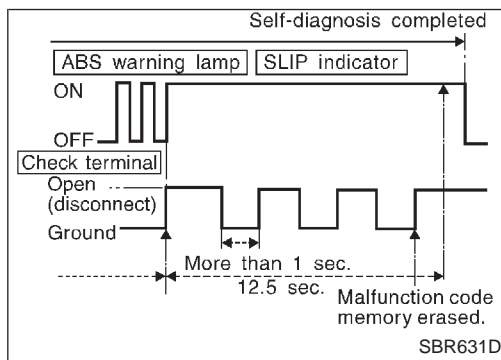
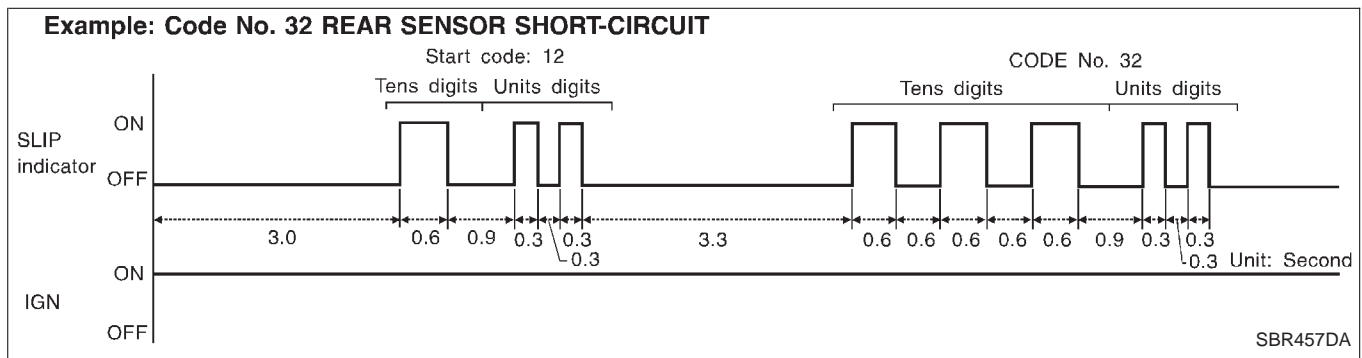

HOW TO ERASE SELF-DIAGNOSTIC RESULTS (Malfunction codes)

- Under the self-diagnostic results mode, the malfunction memory erase mode starts when the check terminal is disconnected from the ground.
- The self-diagnostic results (malfunction codes) can be erased by grounding the check terminal more than three times in succession within 12.5 seconds after the erase mode starts. (Each grounding must be longer than one second.)
The SLIP indicator stays on while the self-diagnosis is in the erase mode, and goes out after the erase operation has been completed. (See NOTE.)
- The self-diagnosis is also completed at the same time. (Refer to BR-59.)

After the erase operation is completed, it is necessary to rerun the self-diagnostic mode to verify that malfunction codes no longer appear. Only the start code (12) should be indicated when erase operation is completed and system is functioning normally.

NOTE: The TCS OFF indicator and ABS warning lamp remain lighted.

TROUBLE DIAGNOSES

Self-diagnosis for ABS/TCS Control Unit (Cont'd)

MALFUNCTION CODE/SYMPTOM CHART

Code No. (No. of SLIP indicator flashes)	Malfunctioning part	Warning lamp	Indicator		Fail-safe	Diagnostic procedure	
		ABS	TCS OFF	SLIP*3			
12	Self-diagnosis could not detect any malfunctions	OFF	OFF	—	15		GI
21	Front right sensor (open-circuit)	ON	ON	X	7		MA
22	Front right sensor (short-circuit)	ON	ON	X	7		EM
25	Front left sensor (open-circuit)	ON	ON	X	7		LC
26	Front left sensor (short-circuit)	ON	ON	X	7		LC
31	Rear right sensor (open-circuit)	ON	ON	X	7		EC
32	Rear right sensor (short-circuit)	ON	ON	X	7		EC
35	Rear left sensor (open-circuit)	ON	ON	X	7		FE
36	Rear left sensor (short-circuit)	ON	ON	X	7		FE
41	Actuator front right outlet solenoid valve	ON	ON	X	8		AT
42	Actuator front right inlet solenoid valve	ON	ON	X	8		AT
45	Actuator front left outlet solenoid valve	ON	ON	X	8		PD
46	Actuator front left inlet solenoid valve	ON	ON	X	8		PD
55	Actuator rear outlet solenoid valve	ON	ON	X	8		FA
56	Actuator rear inlet solenoid valve	ON	ON	X	8		FA
57	Power supply (Low voltage)	ON	ON	—*1	11		RA
58	TAC module communication	OFF	ON	X	2		RA
61	Actuator motor or motor relay	ON	ON	X	10		BR
63	Solenoid valve relay	ON	ON	X	9		BR
71	Control unit	ON	ON*3	X	12		ST
75	LAN communication system failure	OFF	ON	X	6		ST
80	Engine speed signal	OFF	ON	X	3		RS
83	LAN is monitoring	OFF	ON	X	4		RS
84	Engine parts are under fail-safe condition	OFF	ON	X	1		BT
85	LAN communication start procedures are incomplete	OFF	ON	X	5		BT
86	Continued reception after LAN communication starts	OFF	ON	X	—		HA
ABS works frequently	—	—	—	—	28		HA
Unexpected pedal action	—	—	—	—	29		EL
Long stopping distance	—	—	—	—	30		EL
ABS does not work	—	—	—	—	31		EL
Pedal vibration and noise	—	—	—	—	32		EL
SLIP indicator stays on when engine is running	Control unit power supply circuit Warning lamp bulb circuit Control unit or control unit connector Solenoid valve relay stuck Power supply for solenoid valve relay coil	ON	ON	X*2	—		EL
SLIP indicator does not come on when engine is running	Fuse, warning lamp bulb or warning lamp circuit Control unit	ON	ON	X*2	—		EL

X: Available —: Not available

*1: Fail-safe operation does not activate. A signal from control unit suspends TCS and ABS control operation. Brakes operate conventionally.

After specified power supply voltage resumes, TCS OFF indicator and ABS warning lamp go out, allowing for TCS and ABS control operation.

*2: If failure occurs in self-diagnostic check terminal (terminal No. 9 of data link connector) circuit and/or TCS operation (SLIP indicator) circuit, fail-safe operation will not activate.

*3: Only the SLIP indicator can sometimes go out depending on the operating condition of the TCS/ABS control unit.

CONSULT-II for ABS/TCS Control Unit

CONSULT-II APPLICATION TO ABS

ITEM	SELF-DIAGNOSTIC RESULTS	DATA MONITOR	ACTIVE TEST
Front right wheel sensor	X	X	—
Front left wheel sensor	X	X	—
Rear right wheel sensor	X	X	—
Rear left wheel sensor	X	X	—
Stop lamp switch	—	X	—
Engine speed signal	X	X	—
Battery voltage	X	X	—
Front right inlet solenoid valve	X	X	X
Front right outlet solenoid valve	X	X	X
Front left inlet solenoid valve	X	X	X
Front left outlet solenoid valve	X	X	X
Rear inlet solenoid valve	X	X	X
Rear outlet solenoid valve	X	X	X
Actuator solenoid valve relay	X	X	—
Actuator motor relay (ABS MOTOR is shown on the ACTIVE TEST screen.)	X	X	X
ABS/TCS warning lamp	—	X	—
Control unit	X	—	—
ABS motor	X	—	X
Secondary throttle valve	—	X	—
A/T gear position signal	—	X	—
TAC module	X	X	—
TCS OFF indicator lamp	—	X	—
SLIP indicator lamp	—	X	—
ECM	X	—	—
LAN signal	X	—	—

X: Applicable

—: Not applicable

ECU (ABS/TCS control unit) part number mode

Ignore the ECU part number displayed in the ECU PART NUMBER MODE. Refer to parts catalog to order the ECU.

TROUBLE DIAGNOSES

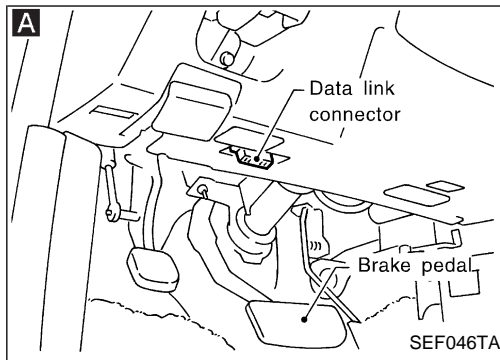

CONSULT-II Inspection Procedure for ABS/TCS Control Unit

SELF-DIAGNOSIS PROCEDURE

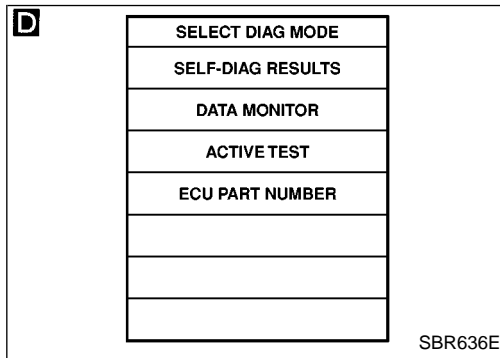
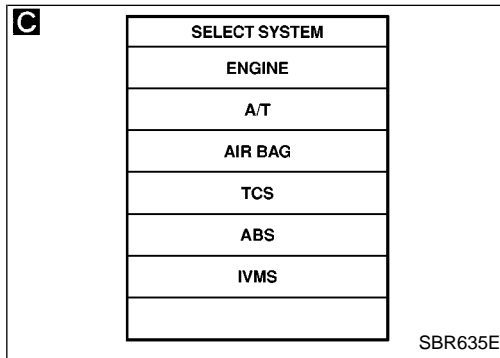
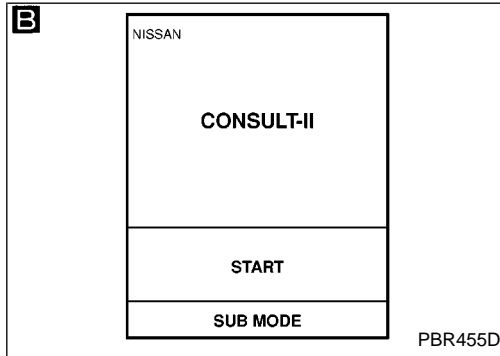

Diagram E shows the "SELF DIAG RESULTS" screen. The table displays the detected failure and the time it occurred.

SELF DIAG RESULTS	
FAILURE DETECTED	TIME
FR RH SENSOR [OPEN]	XXX

A

- 1) Turn ignition switch OFF.
- 2) Connect CONSULT-II to Data Link Connector.

1) Start engine.
2) Drive vehicle over 30 km/h (19 MPH) for at least one minute.

B 1) Stop vehicle with engine running and touch "START" on CONSULT-II screen.
C 2) Touch "ABS".
D E 3) Touch "SELF-DIAG RESULTS".

- The screen shows maximum three malfunctions.
- Does the screen show the detected malfunction?

No → SLIP INDICATOR, TCS OFF INDICATOR AND ABS WARNING LAMP INSPECTION

Check SLIP indicator, TCS OFF indicator, ABS warning lamp and the circuit and repair if necessary.

Yes → MALFUNCTION REPAIR

Make the necessary repairs following the diagnostic procedures.

E

After repairing the malfunctions, start engine. Then erase the self-diagnostic results stored in the control unit by touching "ERASE".

Are the self-diagnostic results erased?

No → SLIP INDICATOR, TCS OFF INDICATOR AND ABS WARNING LAMP INSPECTION

Yes → Check SLIP indicator, TCS OFF indicator, ABS warning lamp for deactivation after driving vehicle over 30 km/h (19 MPH) for at least one minute.

Set TCS OFF indicator to OFF position. Do the SLIP indicator, TCS OFF indicator, ABS warning lamp activate?

Yes → Go to B above.

No → End

Note: "SELF-DIAG RESULTS" screen shows the detected malfunction and the times of ignition switch ON and OFF after it occurred.

GI
MA
EM
LC
EC
FE
AT
PD
FA
RA
BR
ST
RS
BT
HA
EL
IDX

TROUBLE DIAGNOSES

CONSULT-II Inspection Procedure for ABS/TCS Control Unit (Cont'd)

SELF-DIAGNOSTIC RESULTS MODE

Diagnostic item	Diagnostic item is detected when ...	Diagnostic procedure
FR RH SENSOR [OPEN]	<ul style="list-style-type: none"> ● Circuit for front right wheel sensor is open. (An abnormally high input voltage is entered.) 	7
FR LH SENSOR [OPEN]	<ul style="list-style-type: none"> ● Circuit for front left wheel sensor is open. (An abnormally high input voltage is entered.) 	7
REAR RH SENSOR [OPEN]	<ul style="list-style-type: none"> ● Circuit for rear right sensor is open. (An abnormally high input voltage is entered.) 	7
REAR LH SENSOR [OPEN]	<ul style="list-style-type: none"> ● Circuit for rear left sensor is open. (An abnormally high input voltage is entered.) 	7
FR RH SENSOR [SHORT]	<ul style="list-style-type: none"> ● Circuit for front right wheel sensor is shorted. (An abnormally low input voltage is entered.) 	7
FR LH SENSOR [SHORT]	<ul style="list-style-type: none"> ● Circuit for front left wheel sensor is shorted. (An abnormally low input voltage is entered.) 	7
REAR RH SENSOR [SHORT]	<ul style="list-style-type: none"> ● Circuit for rear right sensor is shorted. (An abnormally low input voltage is entered.) 	7
REAR LH SENSOR [SHORT]	<ul style="list-style-type: none"> ● Circuit for rear left sensor is shorted. (An abnormally low input voltage is entered.) 	7
FR RH IN ABS SOL [OPEN]	<ul style="list-style-type: none"> ● Circuit for front right inlet solenoid valve is open. (An abnormally low output voltage is entered.) 	8
FR LH IN ABS SOL [OPEN]	<ul style="list-style-type: none"> ● Circuit for front left inlet solenoid valve is open. (An abnormally low output voltage is entered.) 	8
RR IN ABS SOL [OPEN]	<ul style="list-style-type: none"> ● Circuit for rear inlet solenoid valve is open. (An abnormally low output voltage is entered.) 	8
FR RH IN ABS SOL [SHORT]	<ul style="list-style-type: none"> ● Circuit for front right inlet solenoid valve is shorted. (An abnormally high output voltage is entered.) 	8
FR LH IN ABS SOL [SHORT]	<ul style="list-style-type: none"> ● Circuit for front left inlet solenoid valve is shorted. (An abnormally high output voltage is entered.) 	8
RR IN ABS SOL [SHORT]	<ul style="list-style-type: none"> ● Circuit for rear inlet solenoid valve is shorted. (An abnormally high output voltage is entered.) 	8
FR RH OUT ABS SOL [OPEN]	<ul style="list-style-type: none"> ● Circuit for front right outlet solenoid valve is open. (An abnormally low output voltage is entered.) 	8
FR LH OUT ABS SOL [OPEN]	<ul style="list-style-type: none"> ● Circuit for front left outlet solenoid valve is open. (An abnormally low output voltage is entered.) 	8
RR OUT ABS SOL [OPEN]	<ul style="list-style-type: none"> ● Circuit for rear outlet solenoid valve is open. (An abnormally low output voltage is entered.) 	8
FR RH OUT ABS SOL [SHORT]	<ul style="list-style-type: none"> ● Circuit for front right outlet solenoid valve is shorted. (An abnormally high output voltage is entered.) 	8
FR LH OUT ABS SOL [SHORT]	<ul style="list-style-type: none"> ● Circuit for front left outlet solenoid valve is shorted. (An abnormally high output voltage is entered.) 	8
RR OUT ABS SOL [SHORT]	<ul style="list-style-type: none"> ● Circuit for rear outlet solenoid valve is shorted. (An abnormally high output voltage is entered.) 	8
ABS ACTUATOR RELAY [ON FAILURE]	<ul style="list-style-type: none"> ● Actuator solenoid valve relay is ON, even if control unit sends an OFF signal or relay control lead ground circuit is shorted. 	9
ABS ACTUATOR RELAY [OFF FAILURE]	<ul style="list-style-type: none"> ● Actuator solenoid valve relay is OFF, even if control unit sends an ON signal or relay control lead is open. 	9
ABS MOTOR [ON FAILURE]	<ul style="list-style-type: none"> ● Actuator motor is running, even if control unit sends an OFF signal or relay control lead ground circuit is shorted. 	10
ABS MOTOR [OFF FAILURE]	<ul style="list-style-type: none"> ● Actuator motor is not running, even if control unit sends an ON signal or relay control lead is open. 	10
BATTERY VOLT [VB-HIGH]	<ul style="list-style-type: none"> ● Power source voltage supplied to ABS control unit is abnormally high. 	11
BATTERY VOLT [VB-LOW]	<ul style="list-style-type: none"> ● Power source voltage supplied to ABS control unit is abnormally low. 	11
CONTROL UNIT	<ul style="list-style-type: none"> ● Function of calculation in ABS control unit has failed. 	12
ABS MOTOR [ABNORMAL WHEEL LOCKING]	<ul style="list-style-type: none"> ● ABS motor speed is abnormally low. 	10

TROUBLE DIAGNOSES

CONSULT-II Inspection Procedure for ABS/TCS Control Unit (Cont'd)

Diagnostic item	Diagnostic item is detected when ...	Diagnostic procedure
LAN SIGNAL 1	<ul style="list-style-type: none"> ECM judges that communication signal between ABS/TCS control unit and ECM is abnormal. 	4
LAN SIGNAL 2	<ul style="list-style-type: none"> On the Local Area Network (LAN) between ABS/TCS control unit and ECM, ECM does not transmit the LAN start signal to ABS/TCS control unit. 	5
LAN SIGNAL 3	<ul style="list-style-type: none"> The communication start signal output is not terminated and the ordinary signals are not entered to ABS/TCS control unit. 	—
ENGINE SPEED SIG	<ul style="list-style-type: none"> Engine speed signal from ECM is not entered. 	3
ENGINE SYSTEM	<ul style="list-style-type: none"> Based on the signal from ECM, the ABS/TCS control unit judges that the engine control system is malfunctioning. 	1
TAC COMM	<ul style="list-style-type: none"> The communication signal between ABS/TCS control unit and Throttle Actuator Control Module (TAC Module) is abnormal or this communication line is open or shorted. 	2
LAN CIRCUIT 1	<ul style="list-style-type: none"> The communication line between ABS/TCS control unit and ECM is open or shorted. 	6
LAN CIRCUIT 2	<ul style="list-style-type: none"> An instantaneous signal interruption occurs repeatedly on the communication line between ABS/TCS control unit and ECM. 	6

- If the ABS warning lamp activates and Self-diagnosis could not detect any malfunctions, perform “Diagnostic Procedure 3”.

GI

MA

EM

LC

EC

FE

AT

PD

FA

RA

BR

ST

RS

BT

HA

EL

IDX

TROUBLE DIAGNOSES

CONSULT-II Inspection Procedure for ABS/TCS Control Unit (Cont'd)

DATA MONITOR PROCEDURE

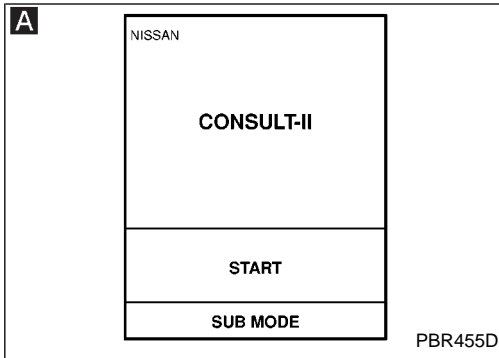

- 1) Turn ignition switch OFF.
- 2) Connect CONSULT-II to Data Link Connector.
- 3) Turn ignition switch ON.

- ↓
- A** 1) Touch "START" on CONSULT-II screen.
 - B** 2) Touch "ABS".
 - C** 3) Touch "DATA MONITOR".

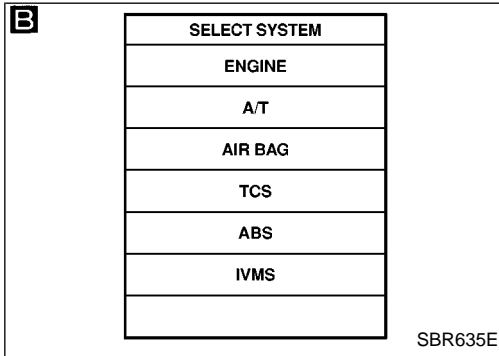

- ↓
- D** 1) Touch "SETTING" on "SELECT MONITOR ITEM" screen.
 - D** 2) Touch "START" on "SELECT MONITOR ITEM".

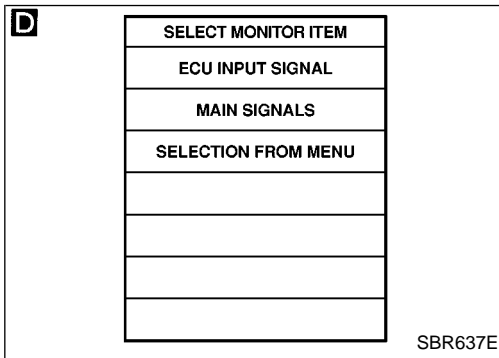
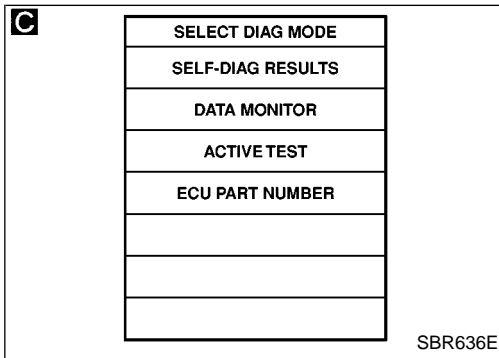

TROUBLE DIAGNOSES

CONSULT-II Inspection Procedure for ABS/TCS Control Unit (Cont'd)

ACTIVE TEST PROCEDURE

- When conducting Active test, vehicle must be stationary.
- When ABS warning lamp stays on, never conduct Active test.

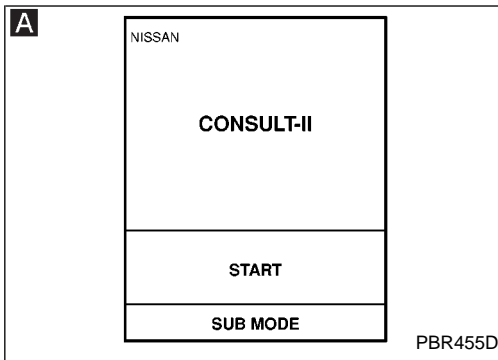

1) Turn ignition switch OFF.
2) Connect CONSULT-II to Data Link Connector.
3) Start engine.

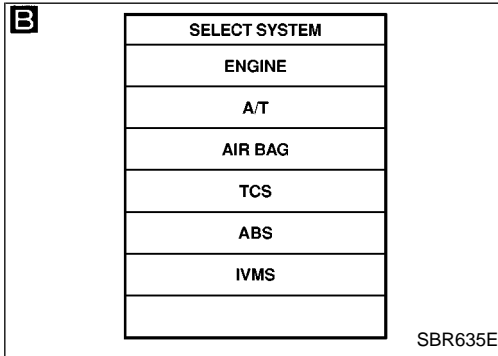

A 1) Touch "START" on CONSULT-II screen.
B 2) Touch "ABS".
C 3) Touch "ACTIVE TEST".

D 1) Select active test item by touching screen.
E 2) Touch "START".

Carry out the active test by touching screen key.

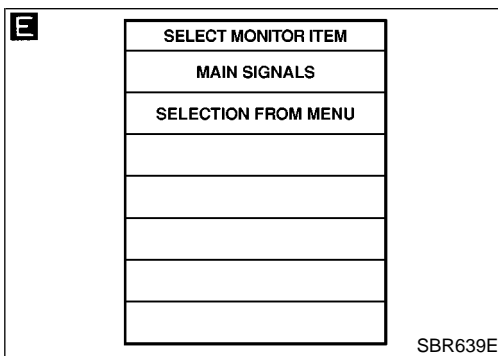
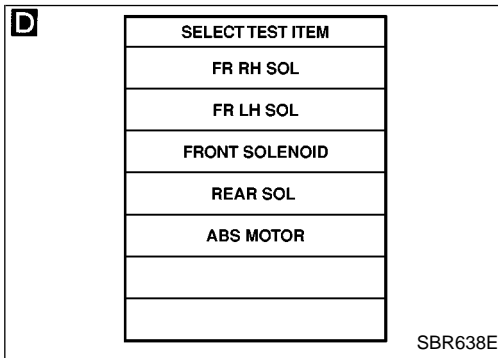
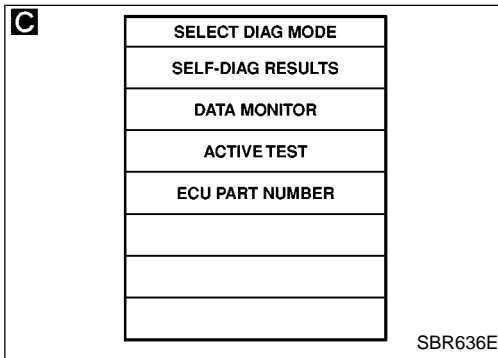

GI
MA
EM
LC
EC
FE
AT
PD
FA
RA
BR
ST
RS
BT
HA
EL
IDX

TROUBLE DIAGNOSES

CONSULT-II Inspection Procedure for ABS/TCS Control Unit (Cont'd)

DATA MONITOR MODE

MONITOR ITEM	CONDITION	SPECIFICATION
FR RH SENSOR FR LH SENSOR RR RH SENSOR RR LH SENSOR	Drive vehicle. (Each wheel is rotating.)	Displays computed vehicle speed from wheel sensor signal. Almost the same speed as speedometer.
STOP LAMP SW	Turn ignition switch ON and depress brake pedal.	Depress the pedal: ON Release the pedal: OFF
ENG RPM SIGNAL	Engine is running.	Engine stops: STOP Engine is running: RUN
FR RH IN SOL FR RH OUT SOL FR LH IN SOL FR LH OUT SOL REAR IN SOL REAR OUT SOL	Ignition switch is turned ON or engine is running.	Operating conditions for each solenoid valve are indicated. ABS is not operating: OFF
ACTUATOR RLY	Ignition switch is turned ON or engine is running.	Displays ON/OFF condition of ABS actuator relay. When turning ignition switch ON, ABS actuator relay is operated.
MOTOR RELAY		ABS is not operating: OFF ABS is operating: ON
WARNING LAMP		Warning lamp is turned on: ON Warning lamp is turned off: OFF
BATTERY VOLT		Power supply voltage for control unit
THRTL OPENING	The throttle valve opening rate (%), calculated and sent by ECM to TAC module, is displayed.	* TAC module: Throttle Actuator Control Module
THL OP TARGET	The secondary throttle valve opening rate (%), which is required by ABS/TCS control unit to TAC module as a target control value, is displayed.	TCS is not operating: 0% (wide open throttle) TCS is operating: 0 - 100%
TCS MODE	The operating cylinder ratio to fuel injected, calculated and sent by ABS/TCS control unit to ECM, is displayed.	TCS is not operating: 0 TCS is operating: 0 - 24* * Displays the number x 3 of cylinders to which fuel supply is cut.
GEAR	A/T gear position signal detected by TCM via ECM is displayed.	Gear position: P, R, N or 1: 1 2: 1 - 2 D: 1 - 4 (O/D "ON"): 1 - 3 (O/D "OFF")
TCS SW	ON/OFF condition of signal from TCS switch is displayed.	TCS OFF S/W (all the time switch is pressed): ON TCS OFF S/W (released): OFF
TCS OFF LAMP	<ul style="list-style-type: none"> ● TCS OFF condition is displayed. ● The condition of malfunctioning TCS is displayed. 	TCS OFF indicator "OFF": OFF TCS OFF indicator "ON": ON
SLIP LAMP	The TCS functioning state is displayed by detecting rear wheel slip.	SLIP indicator "ON": ON SLIP indicator "OFF": OFF
P/N POSI SIG	<ul style="list-style-type: none"> ● Indicates [ON/OFF] condition from the inhibitor switch signal. 	P or N position: ON Other positions: OFF

TROUBLE DIAGNOSES

CONSULT-II Inspection Procedure for ABS/TCS Control Unit (Cont'd)

ACTIVE TEST MODE

TEST ITEM	CONDITION	JUDGEMENT	
FR RH SOLENOID FR LH SOLENOID FRONT SOLENOID REAR SOLENOID	Engine is running.	Brake fluid pressure control operation	
		IN SOL	OUT SOL
		UP (Increase):	OFF
		KEEP (Hold):	ON
		DOWN (Decrease):	ON
ABS MOTOR		ABS actuator motor	
		ON: Motor runs	
		OFF: Motor stops	

Note: Active test will automatically stop ten seconds after the test starts. (EMERGENCY STOP monitor shows ON.)

GI

MA

EM

LC

EC

FE

AT

PD

FA

RA

BR

ST

RS

BT

HA

EL

IDX

TROUBLE DIAGNOSES

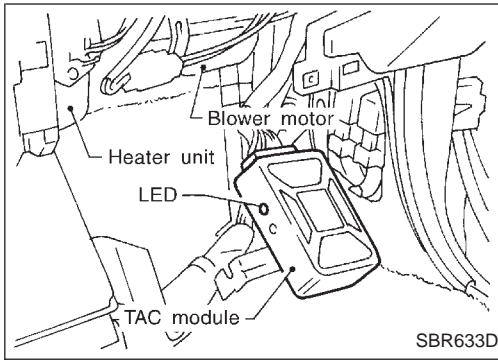

Self-diagnosis for TAC Module

SELF-DIAGNOSIS PROCEDURE

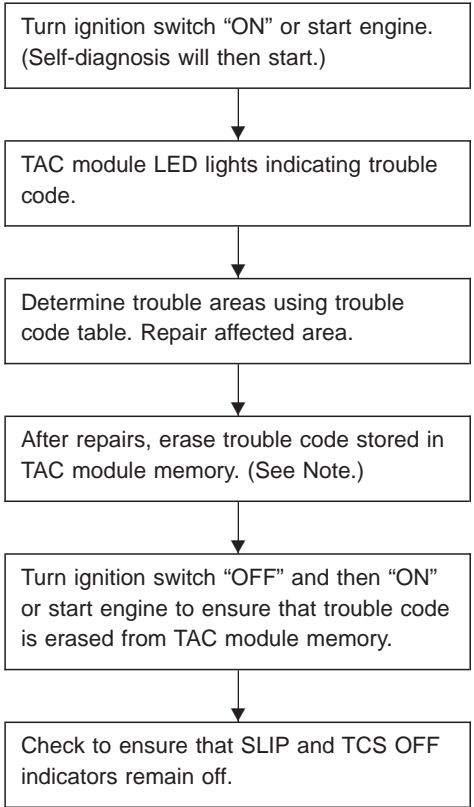

NOTE: Use memory erasure procedures outlined on next page.

HOW TO READ SELF-DIAGNOSTIC RESULTS (Malfunction codes)

- Count the number of TAC module LED flashes (ten digits and unit digits). If multiple troubles occur, their corresponding trouble code numbers will be stored in the memory. For indication pattern, start code number 12 will be indicated first. Following start code number 12, trouble code numbers will be indicated in numerical order, one at a time, and will be repeated.
- If there is no trouble, only trouble code 55 will be repeatedly indicated.
- The malfunction code chart is given on the next page.

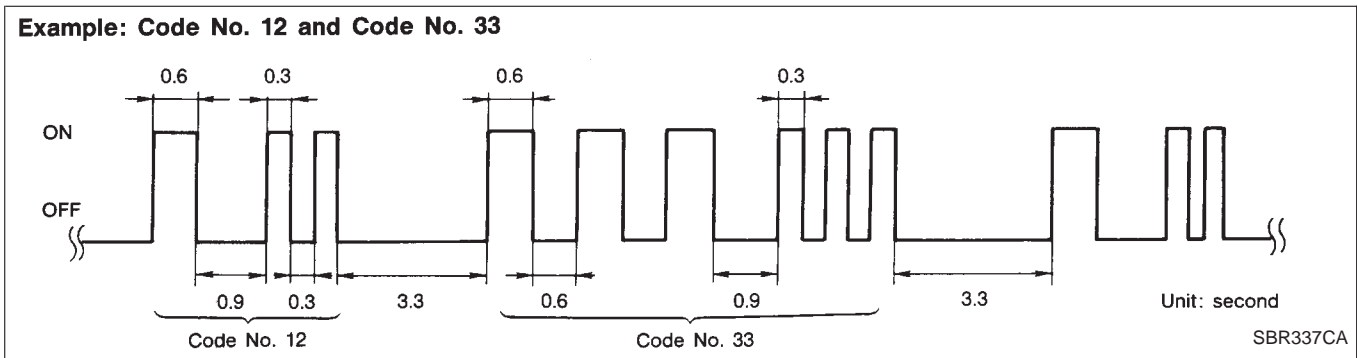

TROUBLE DIAGNOSES

Self-diagnosis for TAC Module (Cont'd)

HOW TO ERASE SELF-DIAGNOSTIC RESULTS (Malfunction codes)

- With accelerator pedal fully depressed (full-open throttle), turn neutral position switch “OFF” and place shift lever in any position other than “P” or “N”.
- After turning ignition switch “ON” (engine off), turn neutral position switch “ON” and place shift lever in “P” or “N”. Release accelerator pedal (full-closed throttle).
- Items indicated in the following table can be erased as per conditions without using erasure procedures outlined above. These items are erased under conditions outlined in the table.

Trouble code No.	Malfunctioning area	Conditions
13	TCS control unit-to-TAC module communication circuit (secondary throttle valve operating signal circuit)	Correct communication synchronization is met.
31	Start signal circuit	Either “OFF → ON” or “ON → OFF” switching of start signal is sensed after ignition switch has been turned “ON”.
33	Park/Neutral position switch circuit	Either “ON → OFF” or “OFF → ON” switching of park/neutral position switch is sensed after ignition switch has been turned “ON”.

After the erase operation is completed, it is necessary to rerun the self-diagnostic mode to verify that malfunction codes no longer appear. Only the Code No. 55 should be indicated when erase operation is completed and system is functioning normally.

MALFUNCTION CODE/SYMPATOM CHART

Code No. (No. of LED flashes)	Malfunctioning part	Indicator		Fail-safe	Diagnostic procedure
		SLIP	TCS OFF		
11	Throttle position sensor circuit	ON	ON	X	14
12	Secondary throttle position sensor circuit	ON	ON	X	15
13	Secondary throttle valve operating signal circuit	ON	ON	X	16
21	Throttle motor circuit (Operation and open circuit check)	ON	ON	X	17
22	Throttle motor circuit (Short circuit check)	ON	ON	X	17
23	Throttle motor relay circuit (Short)	ON	ON	X	18
24	Throttle motor relay circuit (Open)	ON	ON	X	18
31 (See Note.)	Engine start signal circuit	OFF	OFF	—	21
32	Secondary throttle valve return spring broken	ON	ON	X	20
33 (See Note.)	Park/Neutral position switch circuit	OFF	OFF	—	22
34	Power supply circuit (for sensor)	ON	ON	X	19
55	No malfunction in the above circuits	OFF	OFF	—	—

NOTE: Even if start signal and park/neutral position switch circuits become inoperative, TCS control will function properly. Only LEDs flash indicating a malfunctioning area.

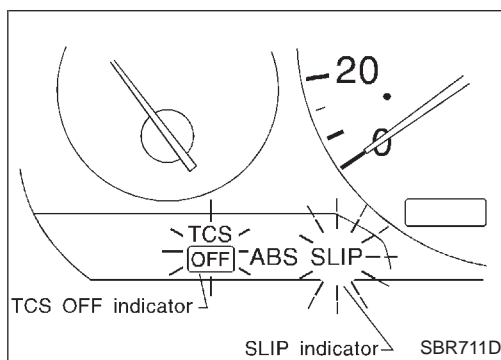

If the system becomes inoperative, the TCS function will be suspended. The fail-safe system will then activate, illuminating the SLIP indicator and TCS OFF indicator. The motor throttle valve will act as one similar to a vehicle which is not equipped with a TCS.

CAUTION:

- If the motor throttle control system becomes inoperative, only the TCS function will be suspended. The ABS function will activate properly.
- If the TCM fail-safe system activates, the self-diagnostic procedure must be performed first on the ABS/TCS control system.

TROUBLE DIAGNOSES

Self-diagnosis for TAC Module (Cont'd)

TCM fail-safe

Self-diagnosis item		Fail-safe condition	
Code No.	Malfunction	Type ①	Type ②
11	Throttle position sensor circuit	X	—
12	Secondary throttle position sensor circuit	X	—
13	Secondary throttle valve operating signal circuit	X	—
21	Throttle motor circuit (Operation and open circuit check)	X	—
22	Throttle motor circuit (Short circuit check)	X	—
23	Throttle motor relay circuit (Short)	X	—
24	Throttle motor relay circuit (Open)	X	—
31	Engine start signal circuit (Short)	—	X
32	Secondary throttle valve return spring broken	—	X
33	Park/Neutral position switch circuit	—	X
34	Power supply circuit (for sensor)	X	—
55	No malfunction in the above circuits	—	—

X: Available

—: Not available

Type ①: Areas whereby throttle operation is uncontrollable.

Type ②: Areas whereby throttle operation is controllable.

CONSULT-II for TAC Module

CONSULT-II APPLICATION TO ABS

ITEM	SELF-DIAGNOSTIC RESULTS	DATA MONITOR	ACTIVE TEST
Throttle position sensor	X	X	—
Secondary throttle position sensor	X	X	X
Closed throttle position switch	—	X	—
Park/Neutral position switch	X	X	—
Throttle motor	X	X	X
Throttle motor relay	X	X	X

X: Applicable

—: Not applicable

ECU (TAC module) part number mode

Ignore the ECU part number displayed in the ECU PART NUMBER MODE. Refer to parts catalog to order the ECU.

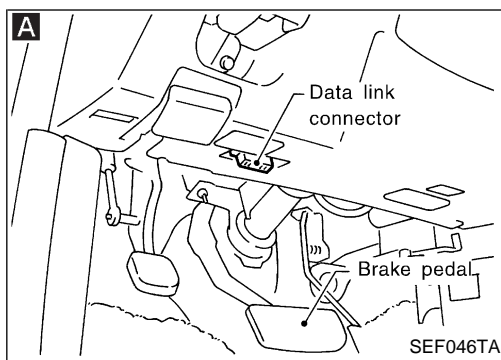

CONSULT-II Inspection Procedure for TAC Module

SELF-DIAGNOSIS PROCEDURE

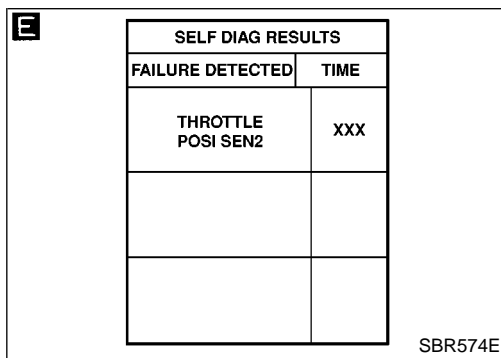
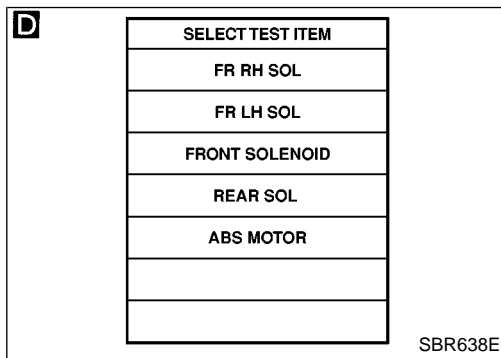
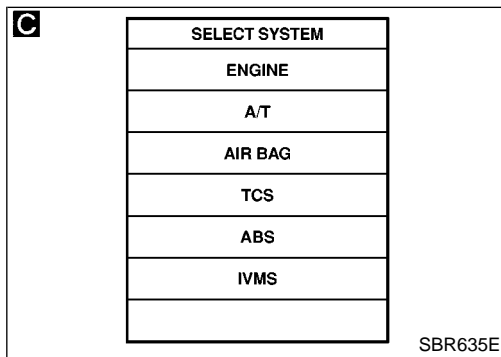
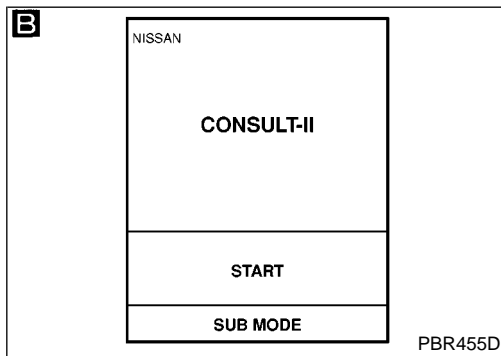

A

- 1) Turn ignition switch OFF.
- 2) Connect CONSULT-II to Data Link Connector.

- 1) Start engine.
- 2) Drive vehicle over 30 km/h (19 MPH) for at least one minute.

B 1) Stop vehicle with engine running and touch "START" on CONSULT-II screen.

C 2) Touch "TCS".

D E 3) Touch "SELF-DIAG RESULTS".

• Does the screen show the detected malfunction?

No

SLIP INDICATOR, TCS OFF INDICATOR INSPECTION

Check SLIP indicator, TCS OFF indicator and the circuit and repair if necessary.

Yes

MALFUNCTION REPAIR

Make the necessary repairs following the diagnostic procedures.

Start engine and drive vehicle at 30 km/h (19 MPH) or more for more than one minute.

Turn ignition switch "OFF" so self-diagnostic system is ready for memory erasure.

E

After repairing the malfunctions, start engine. Then erase the self-diagnostic results stored in the control unit by touching "ERASE".

Are the self-diagnostic results erased?

No

Go to MALFUNCTION REPAIR.

Yes

Check SLIP indicator and TCS OFF indicator for deactivation after driving vehicle over 30 km/h (19 MPH) for at least one minute.

Do the SLIP indicator and TCS OFF indicator activate?

Yes

Go to **B** above.

No

End

Note: "SELF-DIAG RESULTS" screen shows the detected malfunction and the times of ignition switch ON and OFF after it occurred.

GI

MA

EM

LC

EC

FE

AT

PD

FA

RA

BR

ST

RS

BT

HA

EL

IDX

TROUBLE DIAGNOSES

CONSULT-II Inspection Procedure for TAC Module (Cont'd)

SELF-DIAGNOSTIC RESULTS MODE

Display	Self-diagnostic items	Malfunction is detected when ...	Diagnostic procedure
THROTTLE POSI SEN	Throttle position sensor circuit	<ul style="list-style-type: none"> The throttle position sensor circuit is open or shorted. (An abnormally high or low voltage is entered.) 	14
THROTTLE POSI SEN2	Secondary throttle position sensor circuit	<ul style="list-style-type: none"> The secondary throttle position sensor circuit is open or shorted. (An abnormally high or low voltage is entered.) 	15
THRTL POS/S-2 SIG	Secondary throttle valve operating signal circuit	<ul style="list-style-type: none"> TCS control unit is in fail-safe condition or harness is abnormal. Faulty ABS/TCS control unit 	16
THROTTLE ACTUATOR	Throttle motor circuit (Operation and open circuit check)	<ul style="list-style-type: none"> The throttle motor does not operate normally when the TCS is operating. 	17
THROTTLE MOTOR	Throttle motor circuit (Short circuit check)	<ul style="list-style-type: none"> The throttle motor circuit is shorted. 	17
THROTTLE MOTOR RLY [SHORT] (-a)	Throttle motor relay circuit (Short)	<ul style="list-style-type: none"> The throttle motor relay is shorted. 	18
THROTTLE MOTOR RLY [OPEN] (-b)	Throttle motor relay circuit (Open)	<ul style="list-style-type: none"> The throttle motor relay is open. 	18
THRTL/V RETURN SPR	Secondary throttle valve return spring broken	<ul style="list-style-type: none"> Secondary throttle valve does not fully open when current is not supplied to the motor. 	20
ENGINE START SIG	Engine start signal circuit	<ul style="list-style-type: none"> START signal is not properly input due to short-circuit. 	21
NEUTRAL POSI SW	Park/Neutral position switch circuit	<ul style="list-style-type: none"> Park/Neutral position switch circuit is open. Park/Neutral position switch circuit is shorted. 	22
TH P/S PWR SUPPLY	Power supply circuit (for sensor)	<ul style="list-style-type: none"> Power supply circuit for secondary throttle position sensor is open. 	19

NOTE:

Appears on display when self-diagnosis is performed with self-diagnostic check terminal (terminal No. 9 of data link connector) shorted to ground.

TROUBLE DIAGNOSES

CONSULT-II Inspection Procedure for TAC Module (Cont'd)

DATA MONITOR PROCEDURE

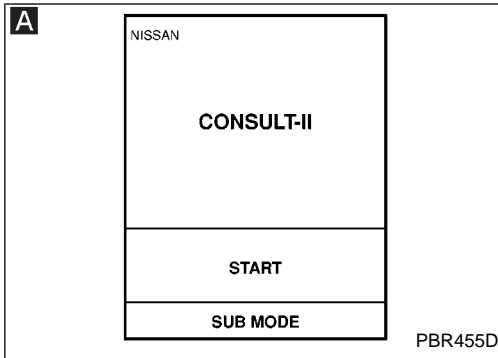

- 1) Turn ignition switch OFF.
- 2) Connect CONSULT-II to Data Link Connector.
- 3) Turn ignition switch ON.

GI
MA

- 1) Touch "START" on CONSULT-II screen.
- 2) Touch "TCS".
- 3) Touch "DATA MONITOR".

EM
LC

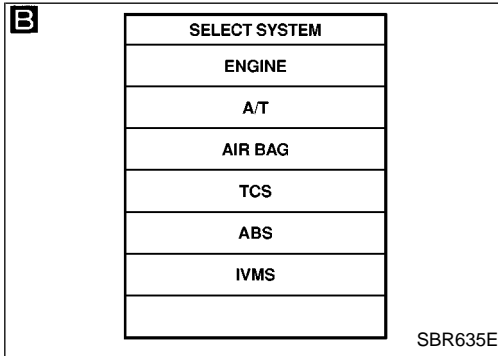

- 1) Touch "SETTING" on "SELECT MONITOR ITEM" screen.
- 2) Touch "START" on "SELECT MONITOR ITEM".

EC
FE

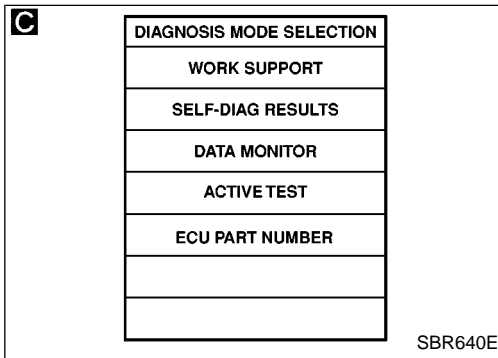

AT
PD

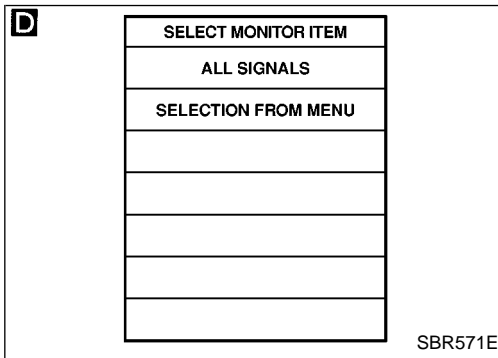

FA
RA

BR

ST
RS

BT
HA

EL
IDX

TROUBLE DIAGNOSES

CONSULT-II Inspection Procedure for TAC Module (Cont'd)

ACTIVE TEST PROCEDURE

- When conducting Active test, vehicle must be stationary.

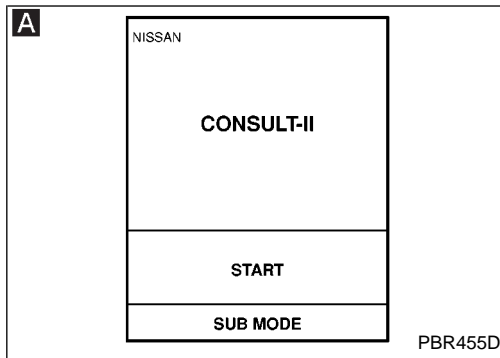

- 1) Turn ignition switch OFF.
- 2) Connect CONSULT-II to Data Link Connector.
- 3) Start engine.

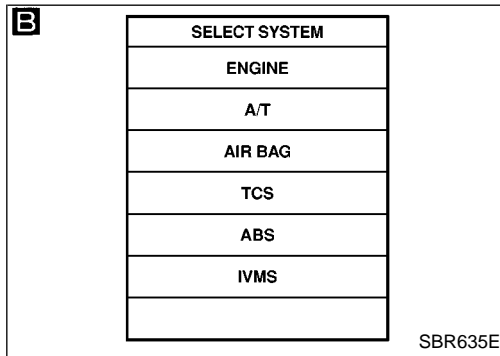

- 1) Touch "START" on CONSULT-II screen.
- 2) Touch "TCS".
- 3) Touch "ACTIVE TEST".

- D**
- 1) Select active test item by touching screen.
 - 2) Touch "START".

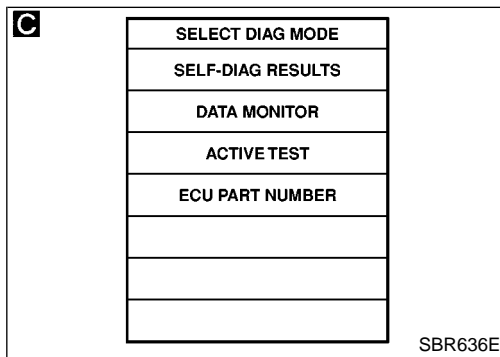

- F**
- 1) Set motor throttle target position to "0°" (throttle fully closed).
Approx. "2°" (motor throttle position) will appear on CONSULT-II display.

- G**
- 1) Following motor throttle target position setting, depress accelerator pedal to ensure that engine speed is limited.
 - 2) Ensure that engine speed is limited in response to different throttle positions.

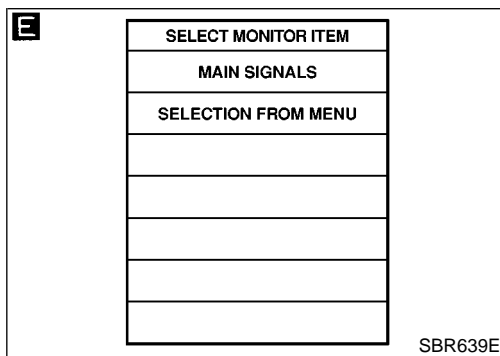
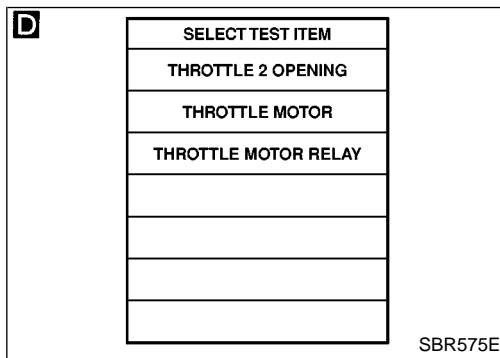

TROUBLE DIAGNOSES

CONSULT-II Inspection Procedure for TAC Module (Cont'd)

F

THROTTLE2 OPENING	XXX
MONITOR	
THRTL POS SEN	XXX

SBR576E

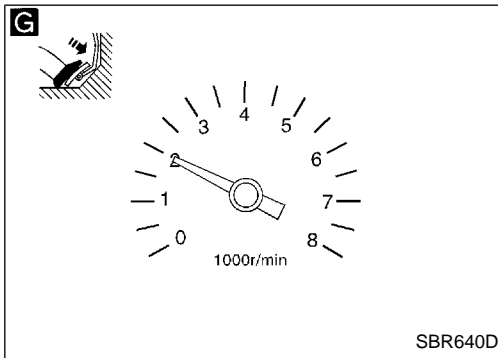

GI

MA

EM

LC

EC

FE

AT

PD

FA

RA

BR

ST

RS

BT

HA

EL

IDX

TROUBLE DIAGNOSES

CONSULT-II Inspection Procedure for TAC Module (Cont'd)

DATA MONITOR MODE

Display	Data monitor items	Description
THRTL POS SEN	Throttle position sensor (V)	● Displays throttle position sensor signal voltage.
THRTL OPENING	Throttle opening angle (degree)	● Displays throttle opening angle calculated from throttle position sensor signal voltage.
THRTL POS SE2	Secondary throttle position sensor (V)	● Displays secondary throttle position sensor signal voltage.
THRL2 OPENING	Secondary throttle valve opening angle (degree)	● Displays secondary throttle valve opening angle calculated from secondary throttle position sensor signal voltage.
BATTERY VOLT	Battery voltage (V)	● Displays power supply voltage for TCM.
TH OPEN SIG	Throttle opening signal (ms)	● Displays pulse width of requesting signal, from TCS control unit.
CLOSED THL/SW	Closed throttle position switch (ON/OFF)	● Displays ON/OFF condition determined by throttle position sensor signal.
NEUT POSI SW	Park/Neutral position switch (ON/OFF)	● Displays ON/OFF condition determined by Park/Neutral position switch signal.
START SIGNAL	Engine start signal	● Displays ON/OFF condition as determined from START signal
TH OPEN CONT	Target secondary throttle opening angle (degree)	● Displays target secondary throttle valve opening angle calculated by TCM.
TH MOTOR VOLT	Motor voltage (V)	● Displays throttle motor driving voltage.
TH MOTOR DUTY	Motor duty (%)	● Displays duty ratio of throttle motor.
TH MOTOR RLY	Motor relay (ON/OFF)	● Displays ON/OFF condition of throttle motor relay.
TCS SIGNAL	TCS operation signal (ON/OFF)	● Displays ON if secondary throttle valve closes more than a certain degree.
TCS FLAG	TCS operation flag	● Displays VALID if TCM controls secondary throttle valve receiving the requesting signal from TCS control unit.
COMM COND	Communication condition (ON/OFF)	● Displays communication condition between TCS control unit and TCM. Displays ON normally.
TH CLSD LRN	Self-learning (DONE/YET)	● Displays self-learning status of fully closed position of secondary throttle valve by TCM.

ACTIVE TEST MODE

Display	Active test items	Description
THROTTLE2 OPENING	Secondary throttle valve opening test	● The target opening angle of secondary throttle valve can be set manually. The opening angle of secondary throttle valve and the duty ratio of throttle motor are displayed in realtime.
THROTTLE MOTOR	Throttle motor operation test	● The duty ratio of throttle motor can be set manually. The opening angle of secondary throttle valve is displayed in realtime.
THROTTLE MOTOR RLY	Throttle motor relay test	● The throttle motor relay can be turned on or off manually or alternatively.

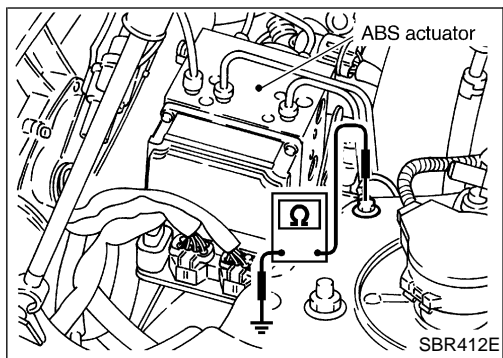

Ground Circuit Check

ABS ACTUATOR MOTOR GROUND

- Check resistance between actuator motor earth terminal and body ground.
Resistance: approximately 0Ω

GI

MA

EM

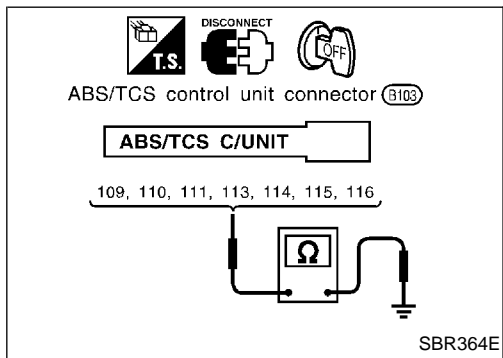

ABS/TCS CONTROL UNIT GROUND

- Check resistance between control unit connector terminals and ground.
Resistance: approximately 0Ω

LC

EC

FE

AT

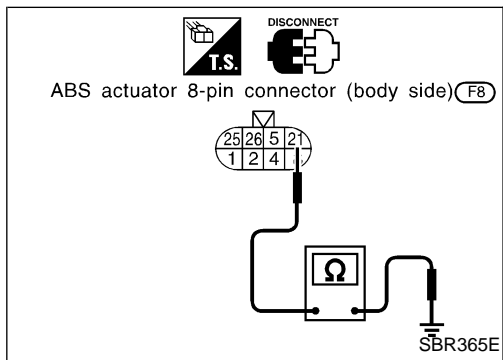

ABS ACTUATOR GROUND

- Check resistance between ABS actuator unit harness 8-pin connector (body side) terminal 21 and ground.
Resistance: approximately 0Ω

PD

FA

RA

BR

ST

RS

BT

HA

EL

IDX

Diagnostic Procedure 1 (Engine system)

Code No. 84 of ABS/TCS control unit

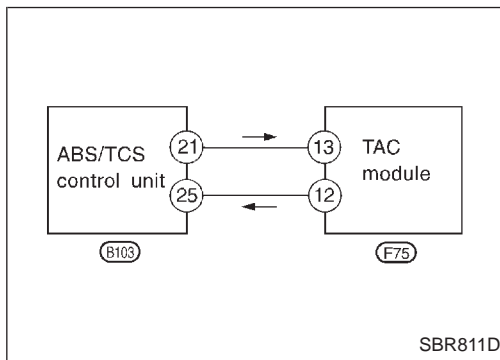
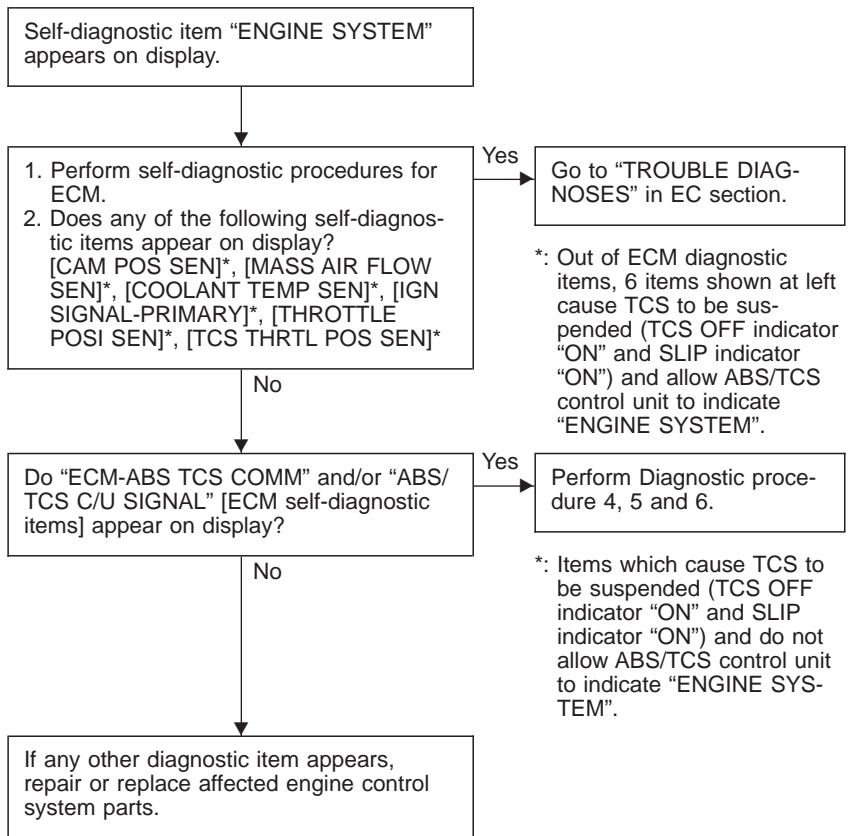

Diagnostic Procedure 2 (TCM COMM: TAC module communication)

COMMUNICATION LINE BETWEEN ABS/TCS CONTROL UNIT AND TAC MODULE

Code No. 58 of ABS/TCS control unit

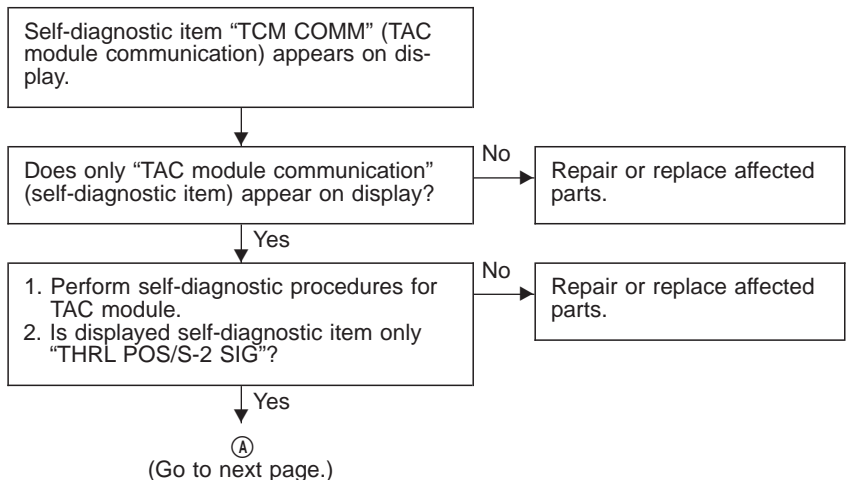

TROUBLE DIAGNOSES FOR SELF-DIAGNOSTIC ITEMS

Diagnostic Procedure 2 (TCM COMM: TAC module communication) (Cont'd)

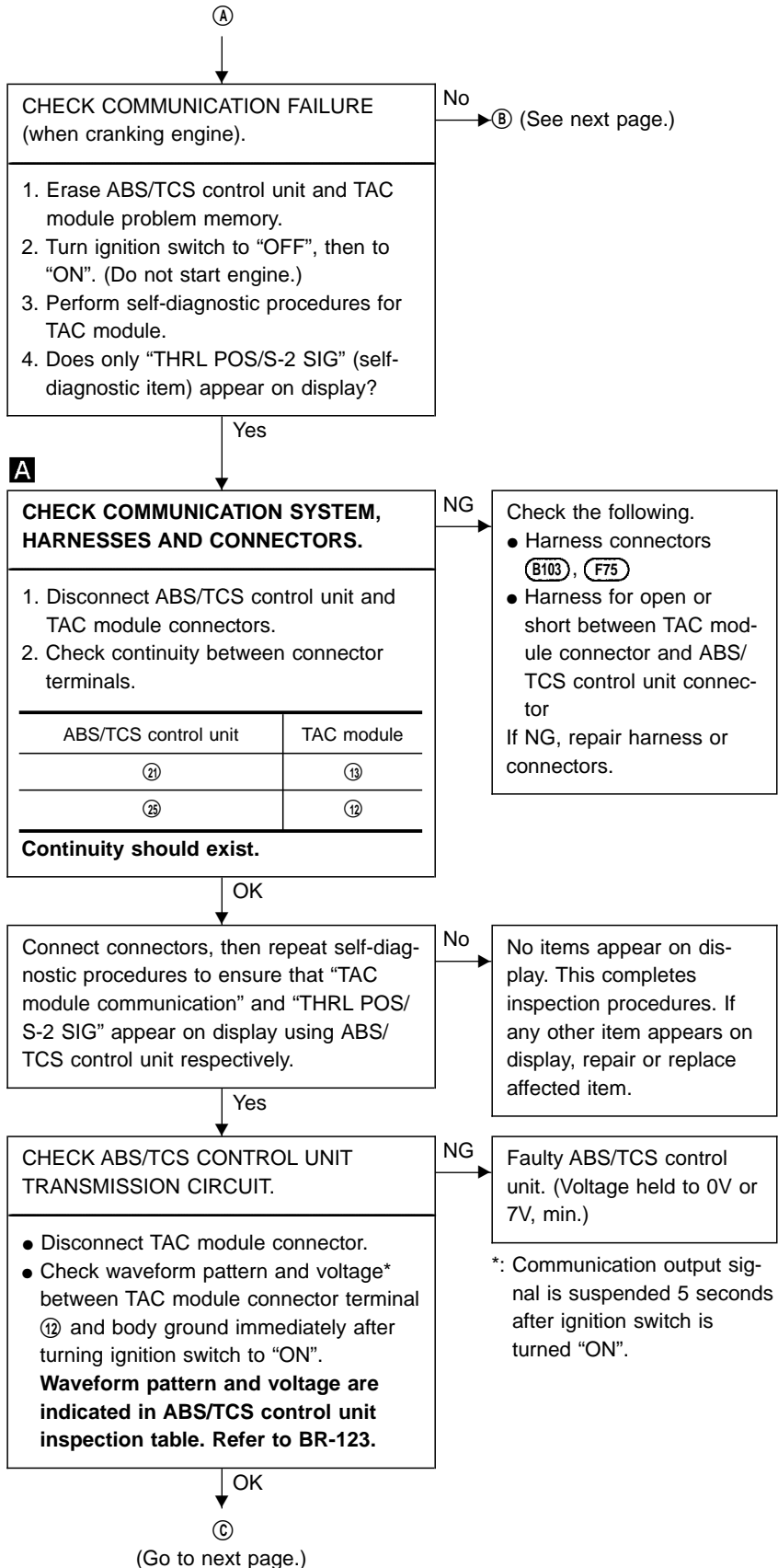
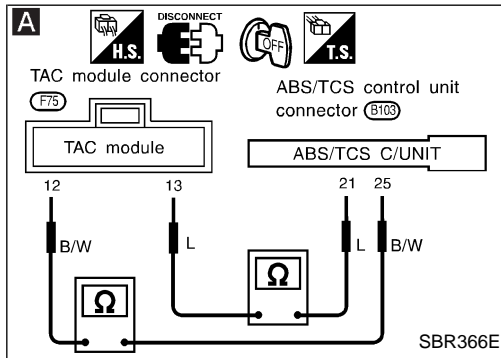

GI
MA
EM
LC
EC
FE
AT
PD
FA
RA
BR
ST
RS
BT
HA
EL
IDX

TROUBLE DIAGNOSES FOR SELF-DIAGNOSTIC ITEMS

Diagnostic Procedure 2 (TCM COMM: TAC module communication) (Cont'd)

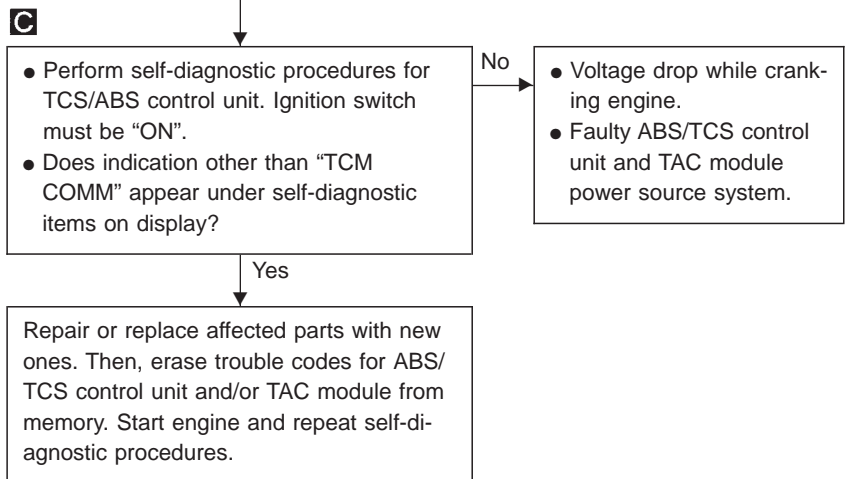
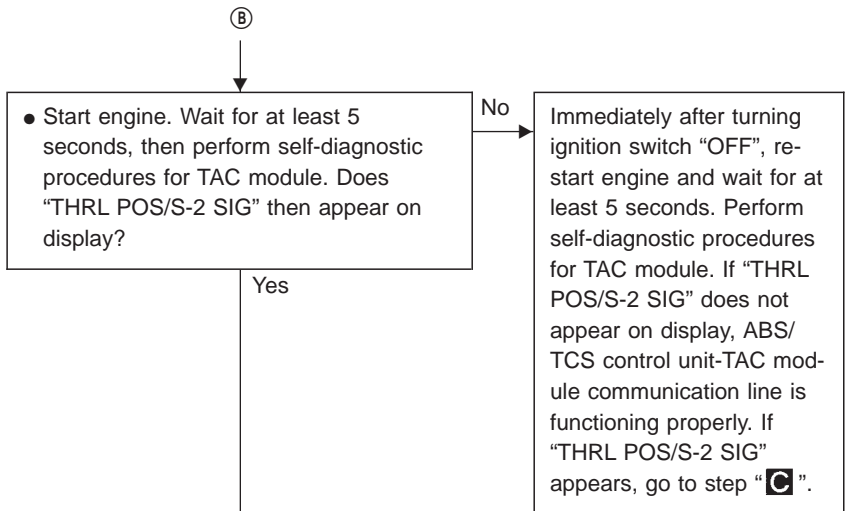
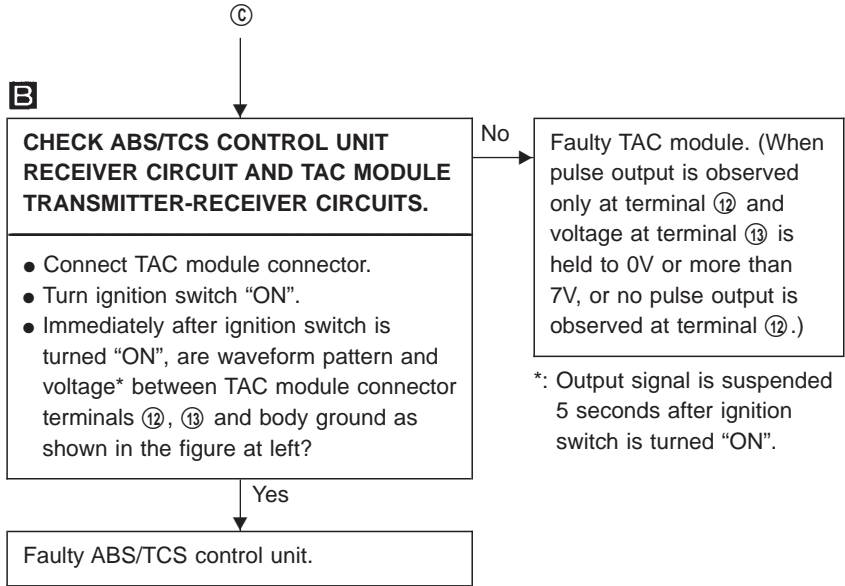
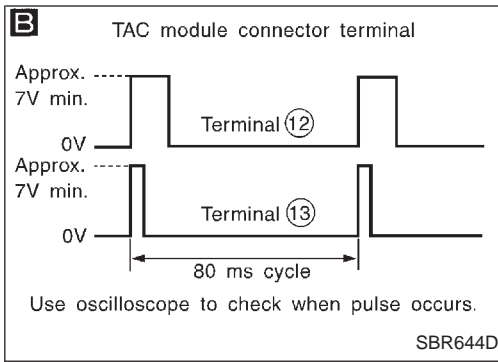

TROUBLE DIAGNOSES FOR SELF-DIAGNOSTIC ITEMS

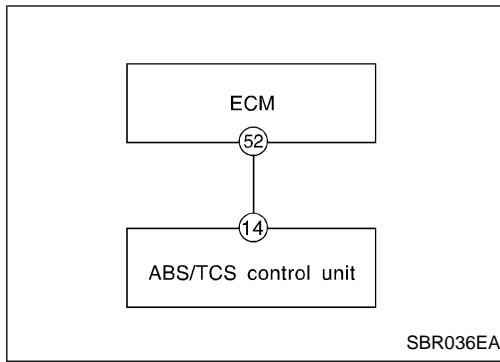

Diagnostic Procedure 3 (Engine speed signal)

Code No. 80 of ABS/TCS control unit

Self-diagnostic item "ENGINE SPEED SIG" appears on display.

1. Perform self-diagnostic procedures for ECM.
2. Does "CAM POS SEN/CIR"* (self-diagnostic item) appear on display?

Yes
Check ECM.
Refer to EC section, "TROUBLE DIAGNOSES".

*: Out of ECM diagnostic items, only "CAM POS SEN/CIR" causes TCS to be suspended (TCS OFF indicator "ON" and SLIP indicator "ON") and allows ABS/TCS control unit to indicate "ENGINE SPEED SIG".

No

Perform self-diagnostic procedures for ECM.
Do "ECM-ABSTCS COMM NG" and "ABS-TCS C/U SIGNAL"* (self-diagnostic items) appear on display?

Yes
Go to diagnostic procedures 4, 5, 6.

No

Disconnect* ABS/TCS control unit and ECM connectors, then reconnect them securely. Repeat self-diagnostic procedures.

OK
Poor connector contact.

*: Check for terminal separation, looseness or bending, etc., at connector housing. If necessary, repair faulty terminals.

NG

CHECK ABS/TCS CONTROL UNIT-TO-ECM HARNESS CONNECTORS.

1. Disconnect ABS/TCS control unit and ECM connectors.
2. Check continuity between terminal ⑭ for ABS/TCS control unit and terminal ⑵ for ECM.
Continuity should exist.

NG
Check the following.
● Harness connectors (F69), (B103)
● Harness for open or short between ECM connectors and ABS/TCS control unit
If NG, repair harness or connectors.

OK

Connect connectors, then repeat self-diagnostic procedures.

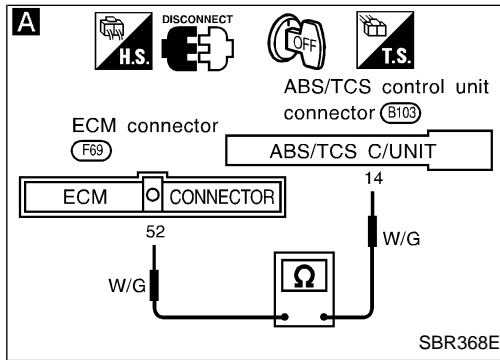

GI
MA
EM
LC
EC
FE
AT
PD
FA
RA
BR
ST
RS
BT
HA
EL
IDX

TROUBLE DIAGNOSES FOR SELF-DIAGNOSTIC ITEMS

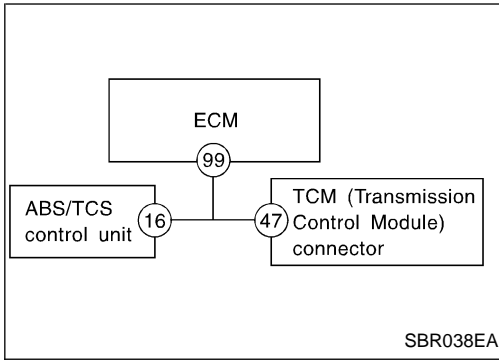

Diagnostic Procedure 4 (LAN SIGNAL 1: LAN monitoring)

Code No. 83 of ABS/TCS control unit

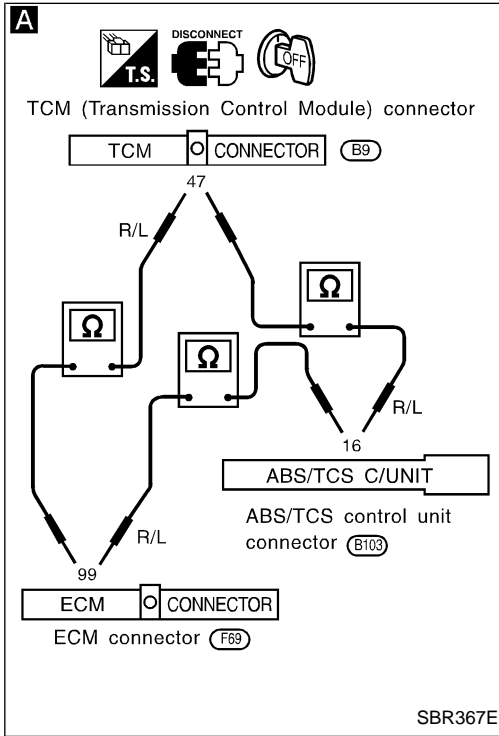
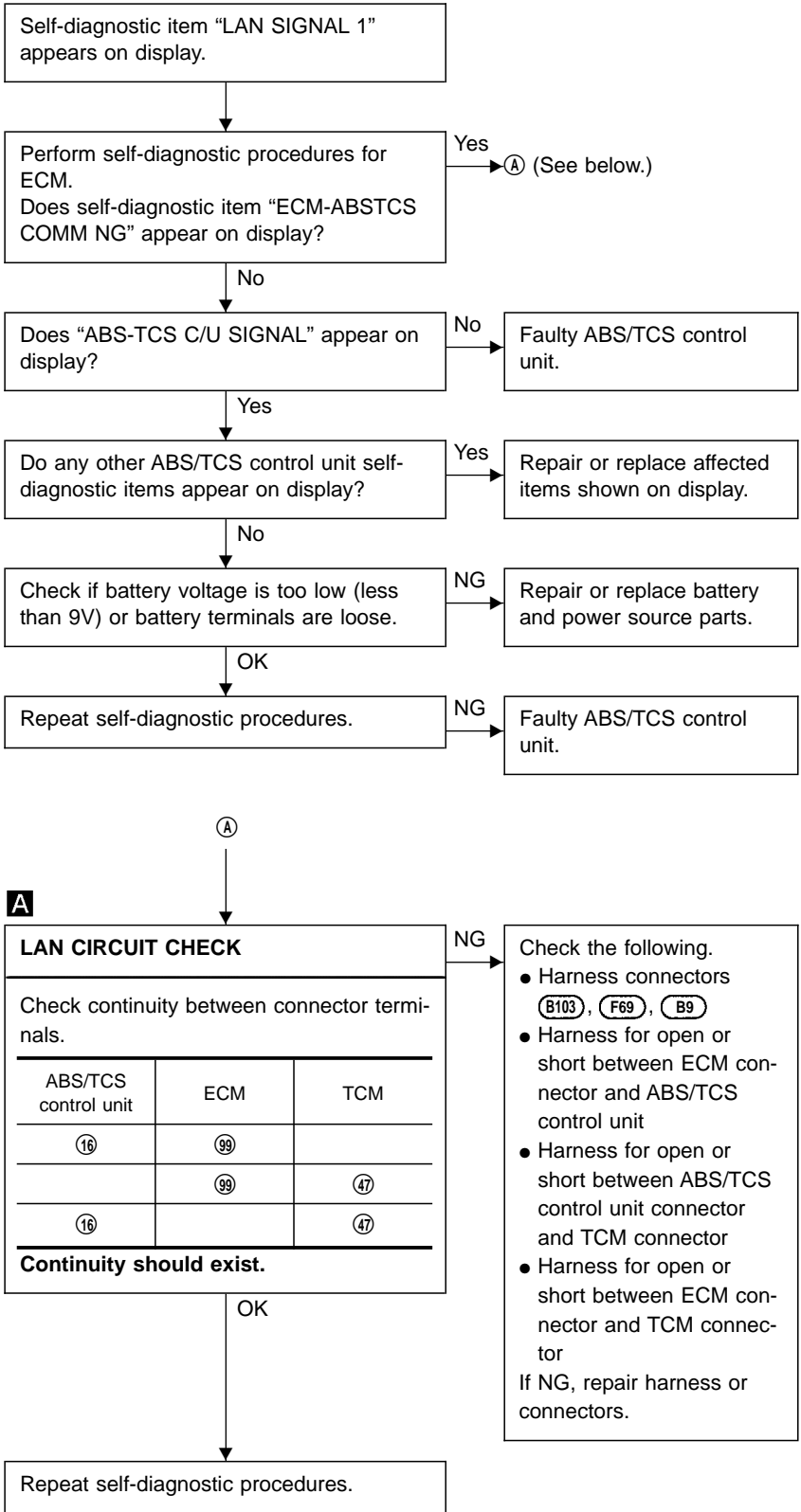

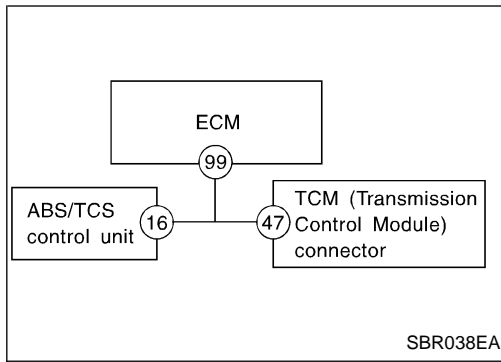

Diagnostic Procedure 5 (LAN SIGNAL 2: LAN communication start procedures incomplete)

Code No. 85 of ABS/TCS control unit

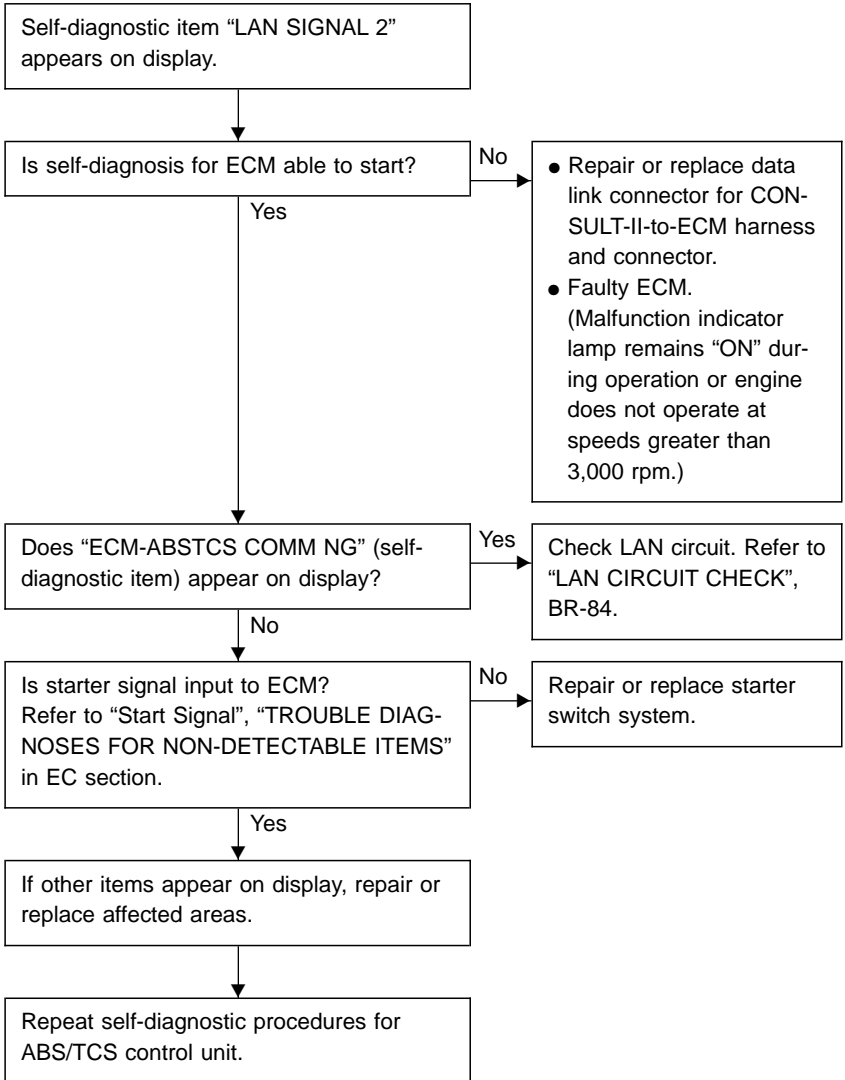

- GI
- MA
- EM
- LC
- EC
- FE
- AT
- PD
- FA
- RA
- BR
- ST
- RS
- BT
- HA
- EL
- IDX

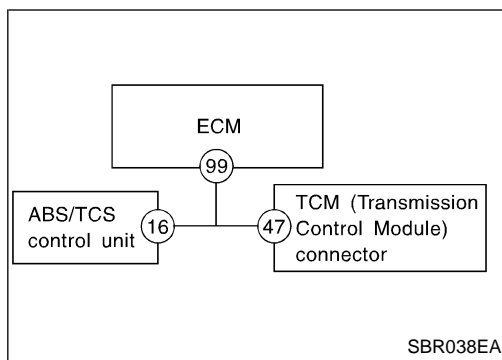

Diagnostic Procedure 6 (LAN CIRCUIT 1/LAN CIRCUIT 2: LAN communication system failure)

Code No. 75 of ABS/TCS control unit

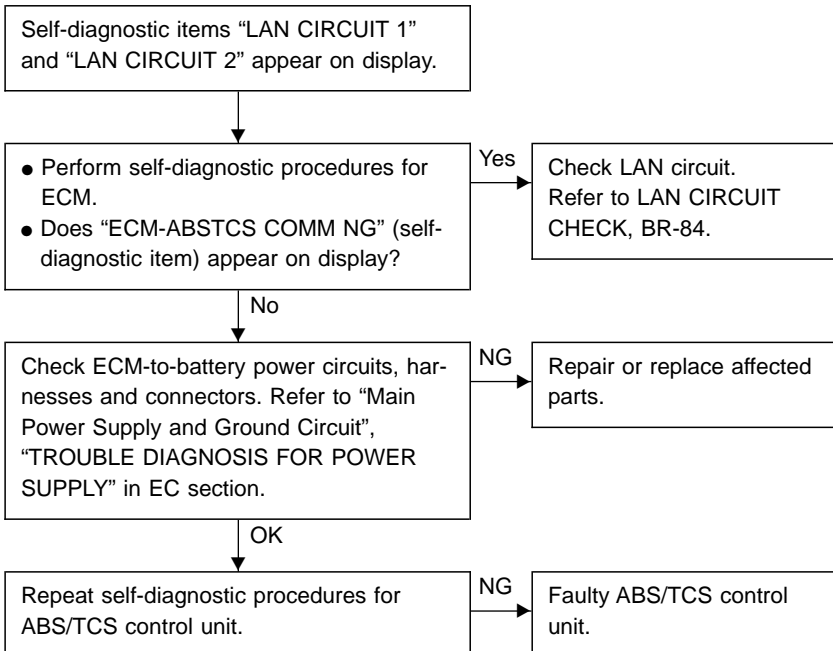

Diagnostic Procedure 7 (Wheel sensor or rotor)

Code No. 21, 22, 25, 26, 31, 32, 35, 36 of ABS/TCS control unit

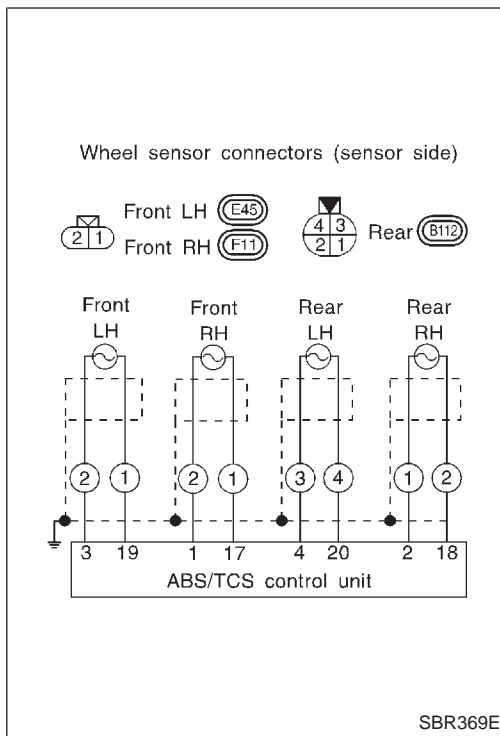

1. Disconnect connectors from ABS/TCS control unit and wheel sensor of malfunction code No. Check terminals for damage or loose connections. Then reconnect connectors.

2. Carry out self-diagnosis again.

Does warning lamp activate again?

No → Inspection end

Yes

A

WHEEL SENSOR ELECTRICAL CHECK

OK → (A) (See next page.)

1. Disconnect ABS/TCS control unit connector.
 2. Check resistance between ABS/TCS control unit connector (B103) terminals.
 - Code No. 25 or 26 (Front LH wheel) Terminals ③ and ⑱
 - Code No. 21 or 22 (Front RH wheel) Terminals ① and ⑰
 - Code No. 31 or 32 (Rear LH wheel) Terminals ④ and ⑳
 - Code No. 35 or 36 (Rear RH wheel) Terminals ② and ⑱
- Resistance: 0.9 - 1.1 kΩ**

NG

B

CHECK WHEEL SENSOR.

- OK →
- Check the following.
- Harness connectors (B103), (E45), (F11), (B112)
 - Harness for open or short between wheel sensor connectors and ABS/TCS control unit
- If NG, repair harness or connectors.

Check each sensor for resistance.

Resistance: 0.9 - 1.1 kΩ

NG

Replace wheel sensor.

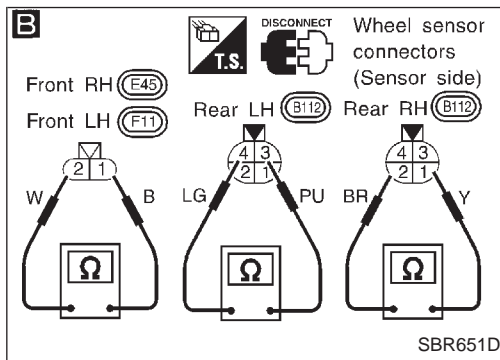
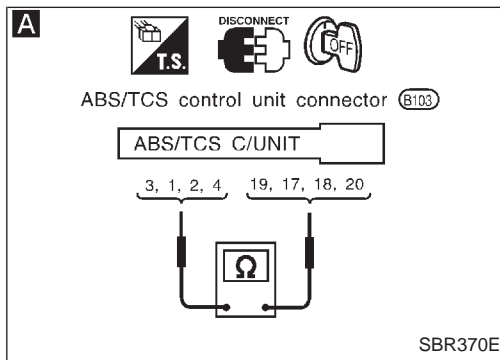

GI
MA
EM
LC
EC
FE
AT
PD
FA
RA
BR
ST
RS
BT
HA
EL
IDX

TROUBLE DIAGNOSES FOR SELF-DIAGNOSTIC ITEMS

Diagnostic Procedure 7 (Wheel sensor or rotor) (Cont'd)

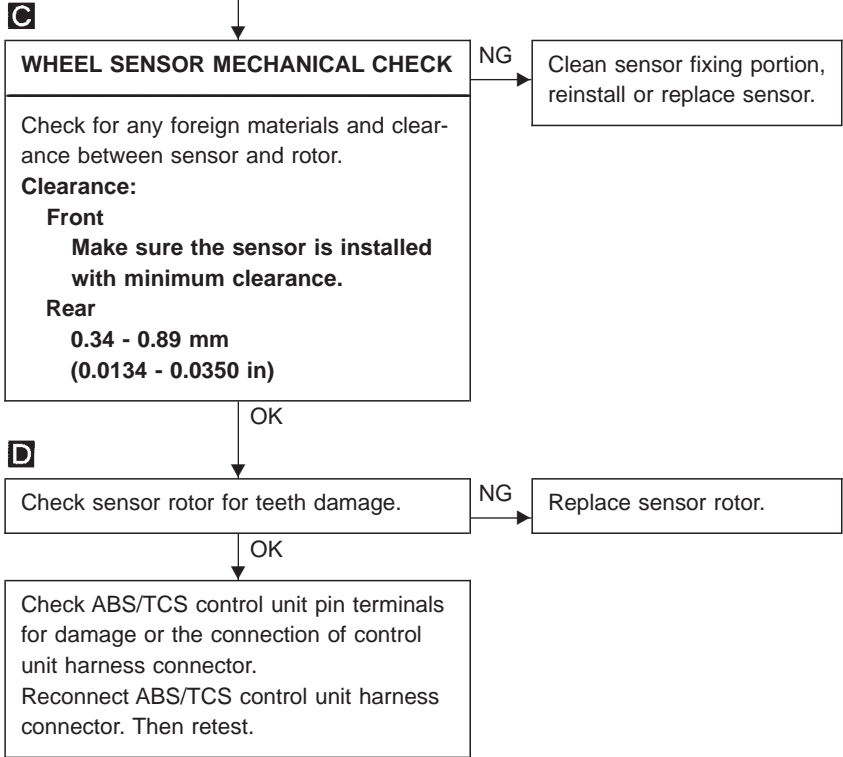
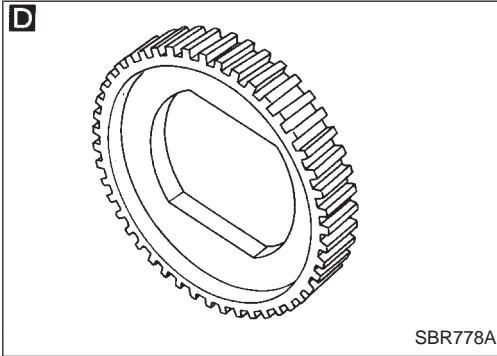
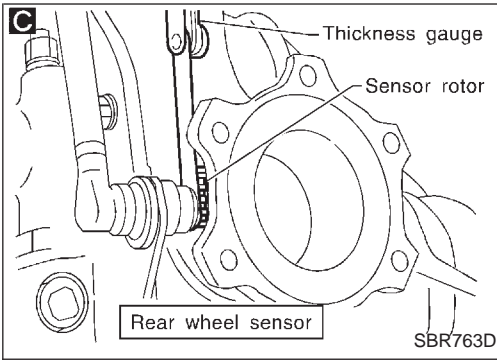

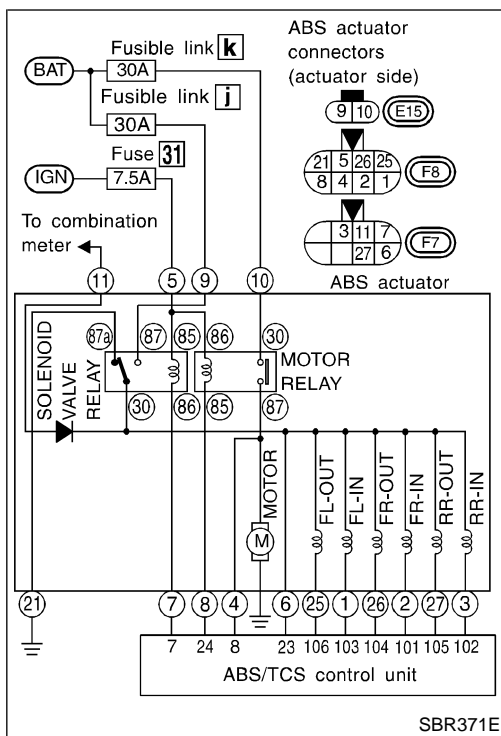

Diagnostic Procedure 8 (ABS actuator solenoid valve)

Code No. 41, 45, 55, 42, 46, 56 of ABS/TCS control unit

1. Disconnect connectors from ABS/TCS control unit, ABS actuator and ABS relay unit. Check terminals for damage or loose connections. Then reconnect connectors.
2. Carry out self-diagnosis again.
Do ABS/TCS warning lamp and TCS OFF indicator activate again?

No → Inspection end

A ABS ACTUATOR SOLENOID VALVE CHECK

1. Disconnect connectors from ABS/TCS control unit.
2. Check resistance between ABS/TCS control unit connector terminals and ground.

Code No.	Control unit	Ground	Resistance
41	(104)	—	2.9 - 6.0Ω
45	(106)	—	
55	(105)	—	
42	(101)	—	5.2 - 10.0Ω
46	(103)	—	
56	(102)	—	

OK → Go to Diagnostic Procedure 9. (See next page.)

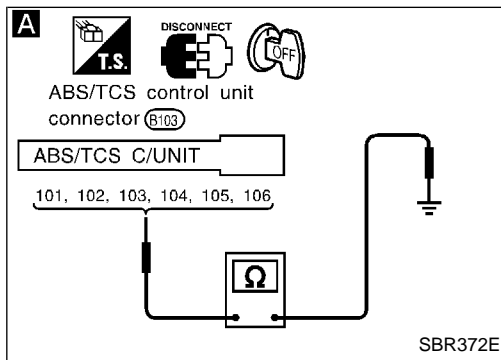

1. Disconnect ABS actuator 8-pin connector.
2. Check resistance between ABS actuator 8-pin connector (F8) (ABS actuator side) terminals and ABS actuator 8-pin connector (F7) or (F8) (ABS actuator side) terminal.

- OK → Check the following.
- Harness connectors (B103), (F8), (F7)
 - Harness for open or short between ABS actuator connector and ABS/TCS control unit connector
 - Harness for open or short between ABS actuator and ground
- If NG, repair harness or connectors.

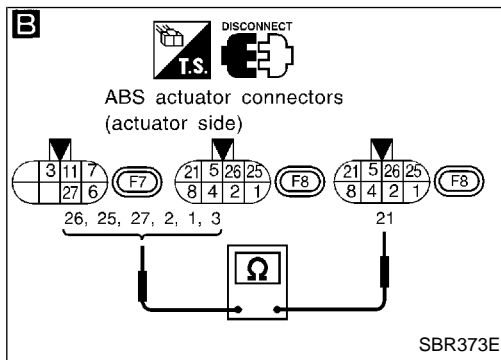

Code No.	ABS actuator		Resistance
	(F7), (F8)	(F8)	
41	(26)	(21)	2.9 - 6.0Ω
45	(26)	(21)	
55	(27)	(21)	
42	(2)	(21)	5.2 - 10.0Ω
46	(1)	(21)	
56	(3)	(21)	

- NG → Check resistance between solenoid valve terminals (1), (25), (2), (26), (3), (27).
Resistance: 8.1 - 16.0Ω

- OK → Check the following.
- Harness connector (F7), (E15), (F8)
 - Harness for open or short between actuator connector terminals
- If NG, repair harness or connectors.

NG → Replace actuator.

GI
MA
EM
LC
EC
FE
AT
PD
FA
RA
BR
ST
RS
BT
HA
EL
IDX

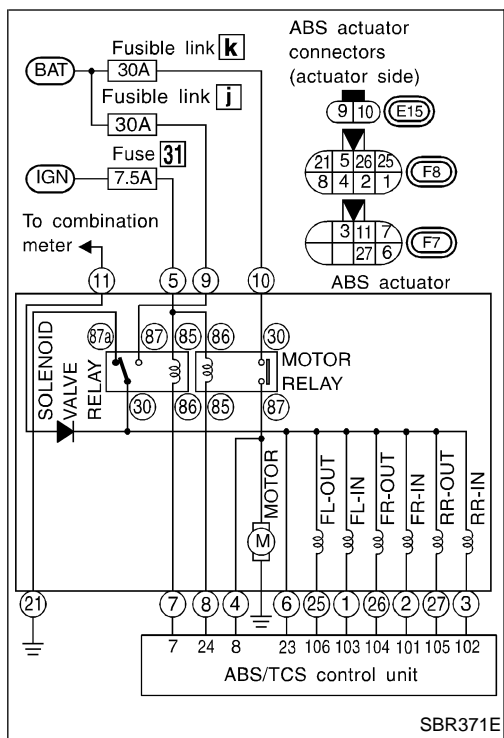

Diagnostic Procedure 9 (Solenoid valve relay)

Code No. 63 of ABS/TCS control unit

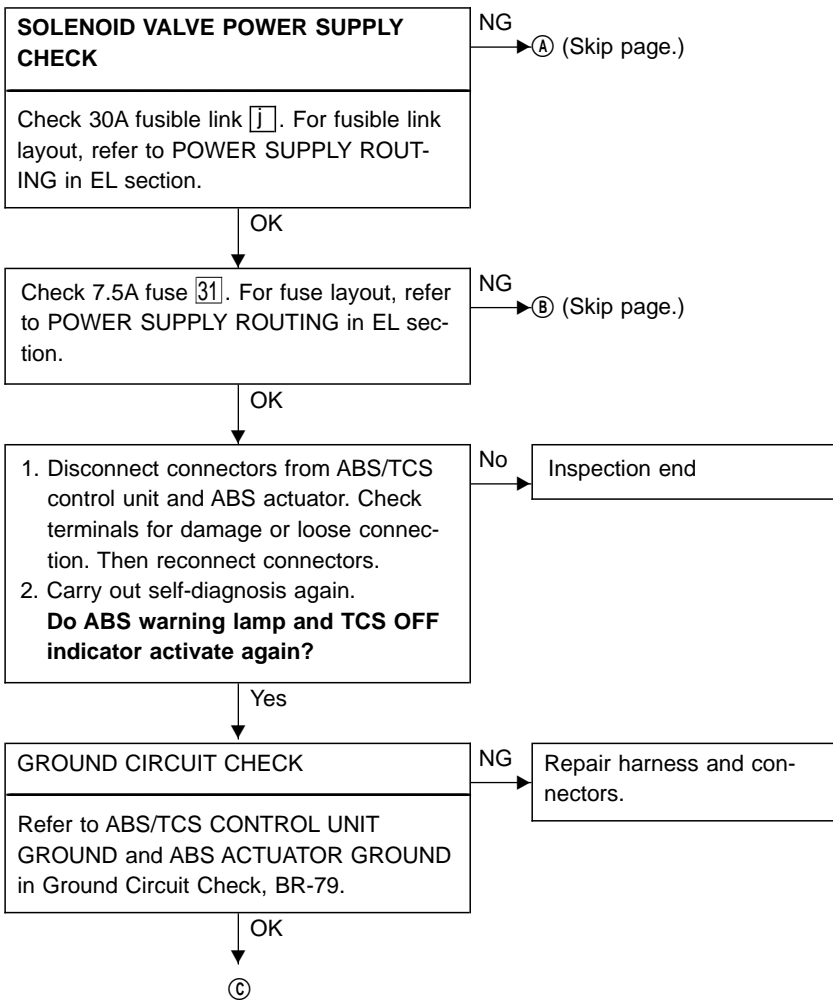

TROUBLE DIAGNOSES FOR SELF-DIAGNOSTIC ITEMS

Diagnostic Procedure 9 (Solenoid valve relay) (Cont'd)

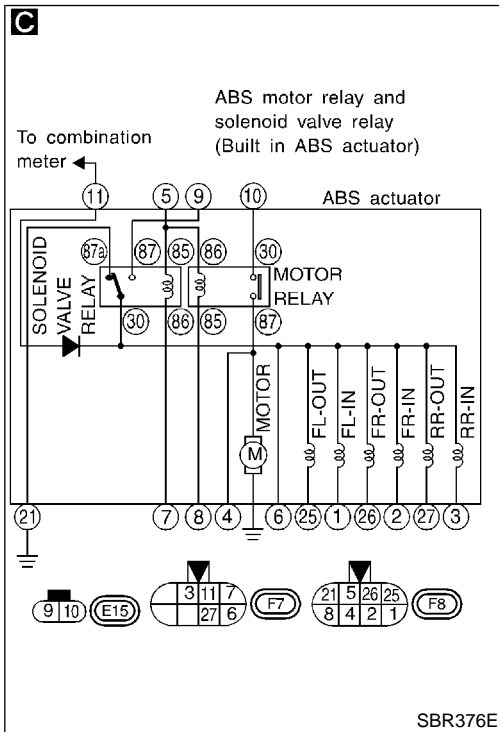
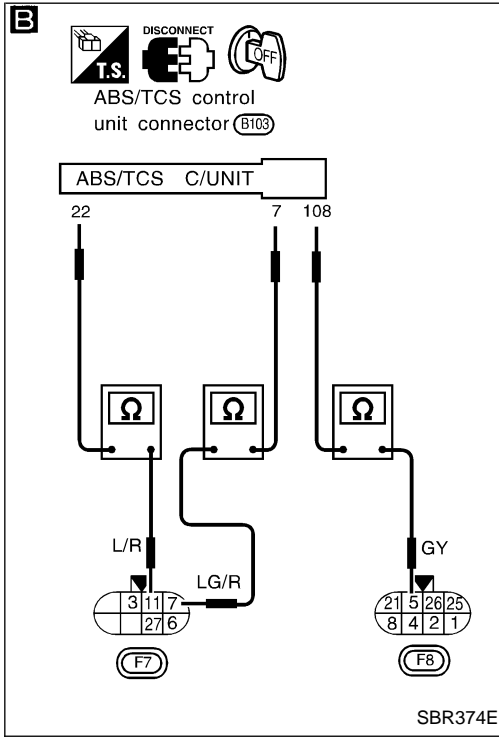
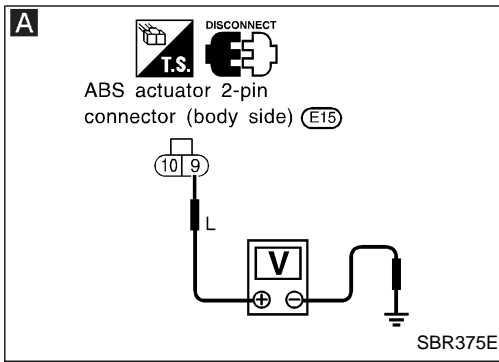

A

SOLENOID VALVE POWER SUPPLY CHECK

1. Disconnect connectors from ABS actuator.

2. Check voltage between ABS actuator 2-pin connector (E15) (body side) terminal ⑨ and ground.

Battery voltage should exist.

NG → Check the following.

- Harness connector (E15)
- Harness for open or short between ABS actuator and fuse

If NG, repair harness or connectors.

B

CIRCUIT CHECK

1. Disconnect ABS actuator 8-pin connector (F7), (F8) and ABS/TCS control unit connectors (B103).

2. Check continuity between ABS/TCS control unit connector terminals and ABS actuator 8-pin connector (F7) (body side) terminals.

Control unit	ABS actuator
⑦	⑦
⑩⑧	⑤
②	⑪

Continuity should exist.

NG → Check the following.

- Harness connectors (F7), (B103), (F8)
- Harness for open or short between ABS actuator terminal (body side) and ABS/TCS control unit

If NG, repair harness or connectors.

C

SOLENOID VALVE RELAY CHECK

NG → Replace ABS actuator.

Condition	Continuity existence between terminals ⑥ and ②
Battery voltage not applied between each terminal	⑤ and ⑦ Yes
Battery voltage applied between each terminal	⑤ and ⑦ No
Check resistance between each terminal	⑤ and ⑦ Approx. 100Ω

OK → Go to Diagnostic Procedure 8, BR-89.

GI
MA
EM
LC
EC
FE
AT
PD
FA
RA
BR
ST
RS
BT
HA
EL
IDX

TROUBLE DIAGNOSES FOR SELF-DIAGNOSTIC ITEMS

Diagnostic Procedure 9 (Solenoid valve relay) (Cont'd)

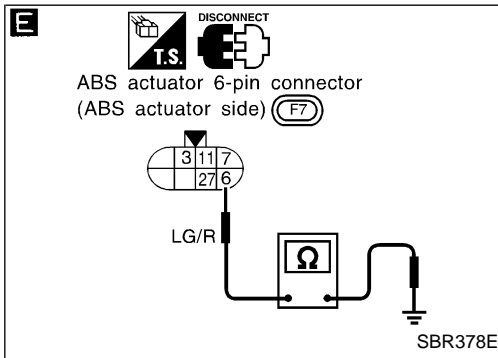
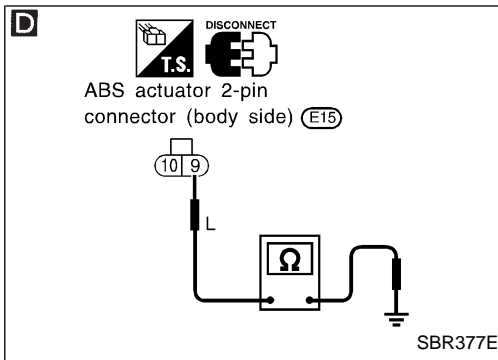

A

Replace fusible link.
Does the fusible link blow out?

No → Inspection end

D

RELAY POWER SUPPLY CIRCUIT

1. Disconnect ABS actuator 2-pin connector (E15).
2. Check continuity between ABS actuator 2-pin connector (E15) (body side) terminal ⑨ and ground.
Continuity should not exist.

NG → Check the following.
● Harness connector (E15)
● Harness for open or short between ABS actuator and fuse
If NG, repair harness or connectors.

E

1. Disconnect ABS actuator connectors and control unit connector.
2. Check continuity between ABS actuator 6-pin connector (F7) (ABS actuator side) terminal ⑥ and ground.
Continuity should exist.

NG → Replace ABS actuator.

OK → Go to Diagnostic Procedure 8, BR-89.

B

Replace fuse.
Does the fuse blow out when ignition switch is turned "ON"?

Yes → Check the following.
● Harness connector (F8)
● Harness for open or short between ABS actuator connector and fuse
If NG, repair harness or connectors.

No → Inspection end

Diagnostic Procedure 10 (Motor relay or motor)

Code No. 61 of ABS/TCS control unit

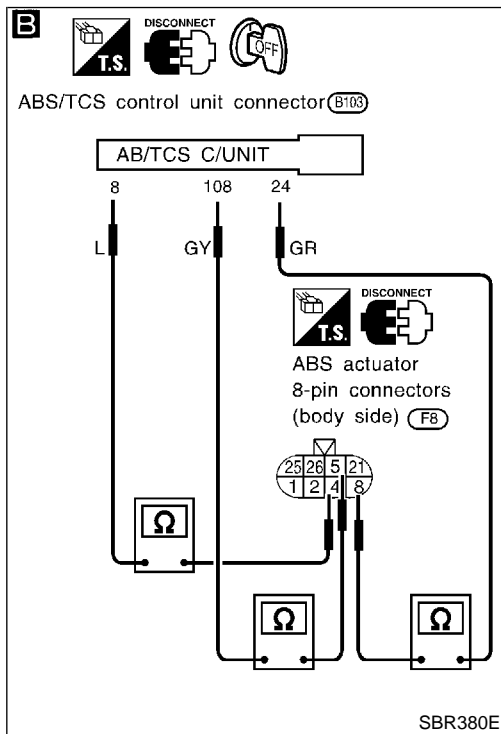
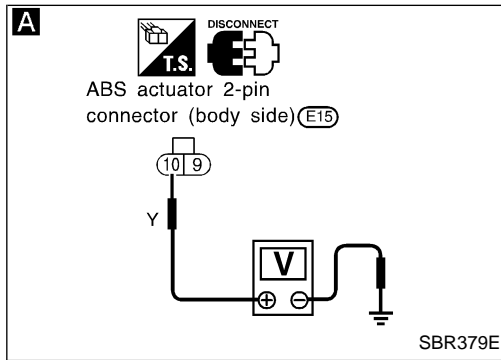
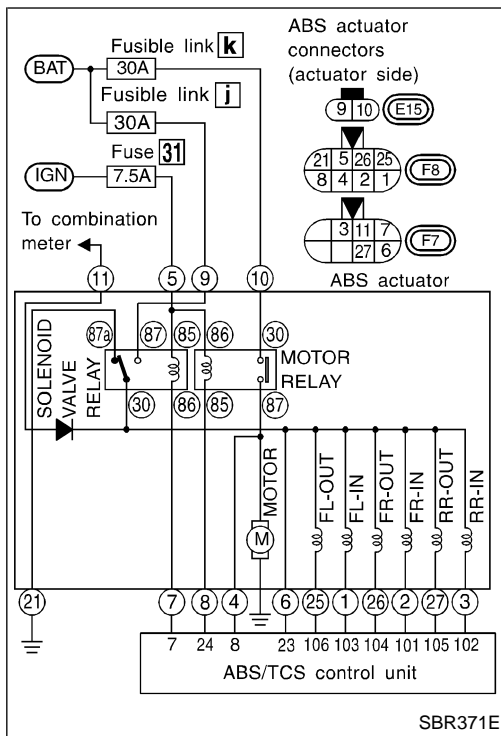

MOTOR POWER SUPPLY CIRCUIT

NG → Ⓑ (Skip page.)

Check 30A fusible link **k** for ABS actuator. For fusible link layout, refer to POWER SUPPLY ROUTING in EL section.

OK ↓

Check 7.5A fuse **31**. For fuse layout, refer to POWER SUPPLY ROUTING in EL section.

NG → Ⓒ (See next page.)

OK ↓

1. Disconnect connectors from ABS/TCS control unit and ABS actuator. Check terminals for damage or loose connection. Then reconnect connectors.
2. Carry out self-diagnosis again.
Do ABS warning lamp and TCS OFF indicator activate again?

No → Inspection end

Yes ↓

A

1. Disconnect ABS actuator 2-pin connector **E15**.
2. Check voltage between connector (body side) terminal **10** and ground.
Battery voltage should exist.

NG → Check the following.
● Harness connector **E15**
● Harness for open or short between ABS actuator and fuse
If NG, repair harness or connectors.

OK ↓

B

CIRCUIT CHECK

NG → Check the following.
● Harness connectors **F8**, **B103**
● Harness for open or short between ABS actuator (body side) and ABS/TCS control unit
If NG, repair harness or connectors.

1. Disconnect ABS actuator 8-pin connector **F8** and ABS/TCS control unit connector **B103**.
2. Check continuity between ABS/TCS control unit connector terminals and ABS actuator 8-pin connector **F8** (body side) terminals.

Control unit	ABS relay unit
24	8
8	4
108	5

Continuity should exist.

OK ↓

Ⓐ
(Go to next page.)

GI
MA
EM
LC
EC
FE
AT
PD
FA
RA
BR
ST
RS
BT
HA
EL
IDX

TROUBLE DIAGNOSES FOR SELF-DIAGNOSTIC ITEMS

Diagnostic Procedure 10 (Motor relay or motor) (Cont'd)

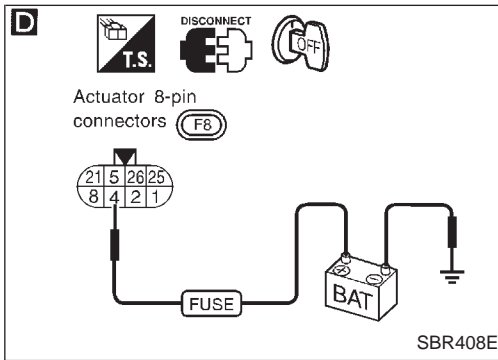
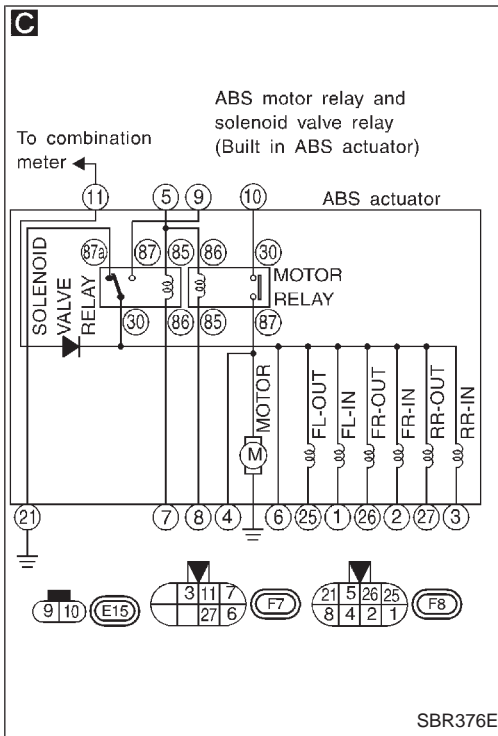

A

C

MOTOR RELAY CHECK

Relay type	ABS motor relay	
Condition	Continuity existence between terminals ④ and ⑩	
Battery voltage not applied between each terminal	⑤ and ⑧	No
Battery voltage applied between each terminal	⑤ and ⑧	Yes
Check resistance between each terminal	⑤ and ⑧	Approx. 100Ω

NG → Replace ABS actuator.

OK

ACTUATOR MOTOR GROUND CHECK

Refer to ABS ACTUATOR MOTOR GROUND in Ground Circuit Check, BR-79.

NG → Repair harness and terminals.

OK

D

MOTOR CHECK

1. Disconnect ABS actuator connector.
2. Apply battery voltage to 8-pin connector terminal ④ (actuator side) and ground. **MOTOR should operate. Do not apply battery voltage more than 5 seconds.**

NG → Replace ABS actuator.

OK

Go to Diagnostic Procedure 11, BR-96.

C

Replace fuse.

Does the fuse blow out when ignition switch is turned "ON"?

Yes → Check the following.

- Harness connector (F8)
- Harness for open or short between ABS actuator connector and fuse

If NG, repair harness or connectors.

No → Inspection end

TROUBLE DIAGNOSES FOR SELF-DIAGNOSTIC ITEMS

Diagnostic Procedure 10 (Motor relay or motor) (Cont'd)

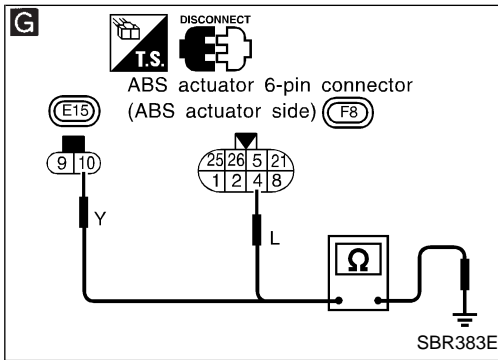
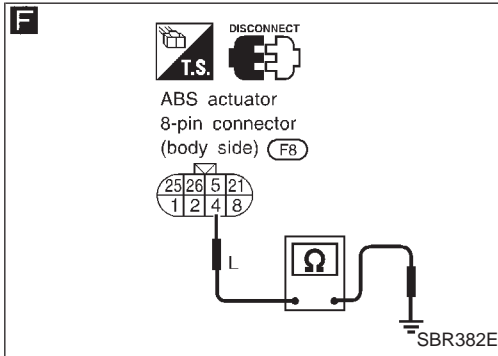
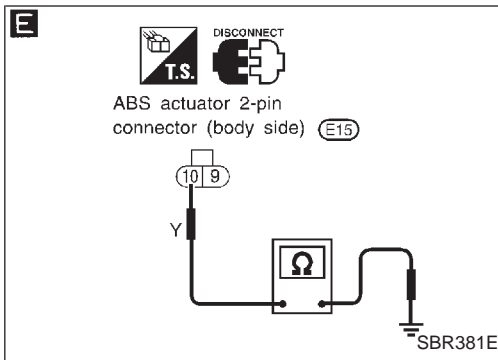

B

Replace fusible link.
Does the fusible link blow out?

No → Inspection end

E

MOTOR POWER SUPPLY CIRCUIT

1. Disconnect battery cable and ABS actuator 2-pin connector (E15).
 2. Check continuity between ABS actuator 2-pin connector (E15) (body side) terminal ⑩ and ground.
Continuity should not exist.

NG → Check the following.
 ● Harness connector (E15)
 ● Harness for open or short between ABS actuator and fuse
 If NG, repair harness or connectors.

F

1. Disconnect ABS actuator 8-pin connector and control unit connector.
 2. Check continuity between ABS actuator 8-pin connector (F8) (body side) terminal ④ and ground.
Continuity should not exist.

NG → Check the following.
 ● Harness connectors (B103, F8)
 ● Harness for open or short between ABS actuator (body side) and ABS/TCS control unit
 If NG, repair harness or connectors.

G

Check continuity between ABS actuator 8-pin connector (F8) (ABS actuator side) terminal ④ and ground, 2-pin connector (E15) (ABS actuator side) terminal ⑩ and ground.
Continuity should not exist.

NG → Replace ABS actuator.

MOTOR CHECK

Go to **D** in Diagnostic Procedure 10 (preceding page).

Check ABS/TCS control unit pin terminals for damage or the connection of ABS/TCS control unit harness connector. Reconnect ABS/TCS control unit harness connector. Then retest.

GI
MA
EM
LC
EC
FE
AT
PD
FA
RA
BR
ST
RS
BT
HA
EL
IDX

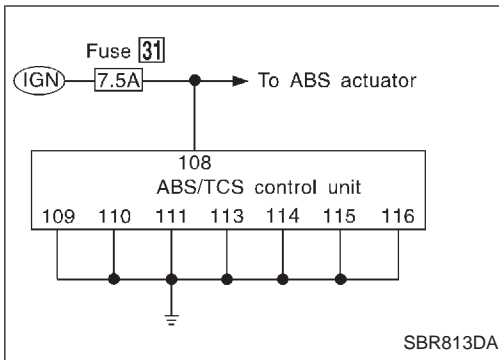

Diagnostic Procedure 11 (BATTERY VOLT: Low voltage)

Code No. 57 of ABS/TCS control unit

1. Disconnect ABS/TCS control unit connectors. Check terminals for damage or loose connections. Then reconnect connectors.
 2. Carry out self-diagnosis again.
Do ABS warning lamp, TCS OFF indicator activate again?

No → Inspection end

Yes

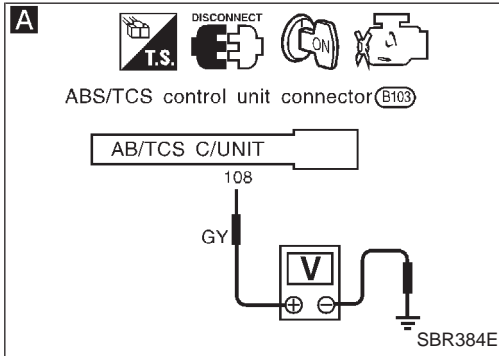

A
CONTROL UNIT POWER SUPPLY CHECK

1. Disconnect ABS/TCS control unit connector.
 2. Check voltage between ABS/TCS control unit connector terminal (108) and ground.
Battery voltage should exist when ignition switch is turned ON.

NG → (A) (See below.)

OK

CONTROL UNIT GROUND CHECK

Refer to ABS/TCS CONTROL UNIT GROUND in Ground Circuit Check, BR-79.

NG → Repair harness and connectors.

OK

Check ABS/TCS control unit pin terminals for damage or the connection of ABS/TCS control unit harness connector. Reconnect ABS/TCS control unit harness connector. Then retest.

(A)

Check 7.5A fuse 31. Refer to POWER SUPPLY ROUTING in EL section.

NG → Replace fuse.

OK

Check continuity between battery and ABS/TCS control unit connector terminal (108).

NG → Check the following.
 ● Harness connector (B103)
 ● Harness for open or short between ABS/TCS control unit and fuse
 If NG, repair harness or connectors.

OK

Check battery. Refer to BATTERY in EL section.

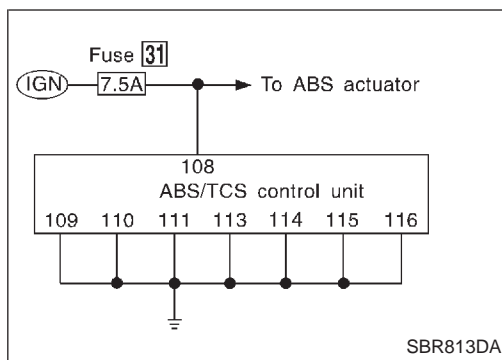

Diagnostic Procedure 12 (Control unit)

Code No. 71 of ABS/TCS control unit

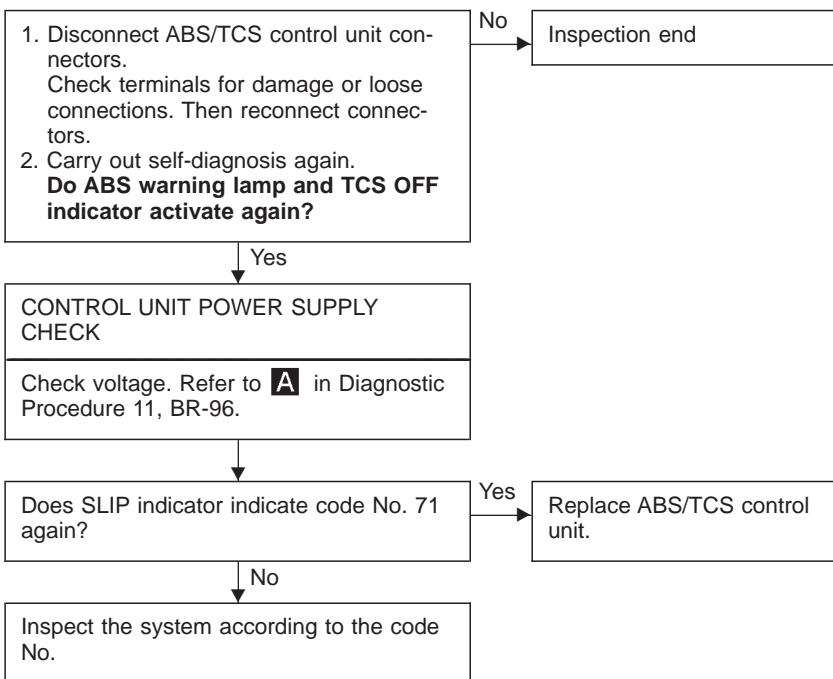

- GI
- MA
- EM
- LC
- EC
- FE
- AT
- PD
- FA
- RA
- BR**
- ST
- RS
- BT
- HA
- EL
- IDX

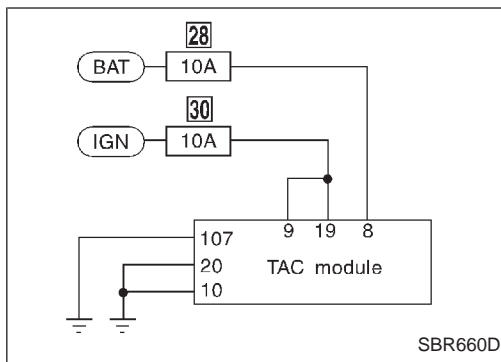

Diagnostic Procedure 13 (Power supply and ground circuit for TAC module)

Code No. 0 ... LED of TAC module does not blink

1. Disconnect TAC module connectors. Check terminals for damage or loose connections. Then reconnect connectors.
 2. Carry out self-diagnosis again.
Do SLIP indicator and TCS OFF indicator activate again?

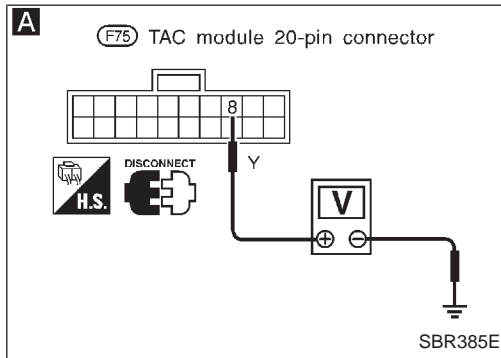

A CONTROL UNIT POWER SUPPLY CHECK

1. Disconnect TAC module connector.
 2. Check voltage between TAC module connector terminal ⑧ and ground.
Battery voltage should exist.

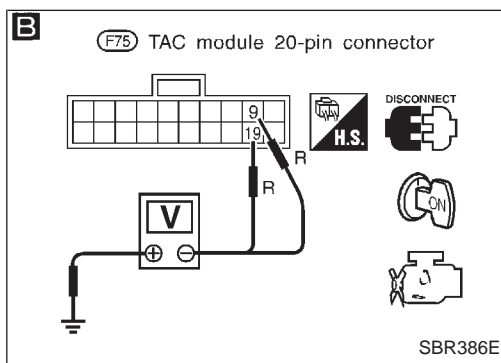

B CONTROL UNIT POWER SUPPLY CHECK

1. Disconnect TAC module connector.
 2. Check voltage between TAC module connector terminal ⑨, ⑲ and ground.
Battery voltage should exist when ignition switch is turned ON.

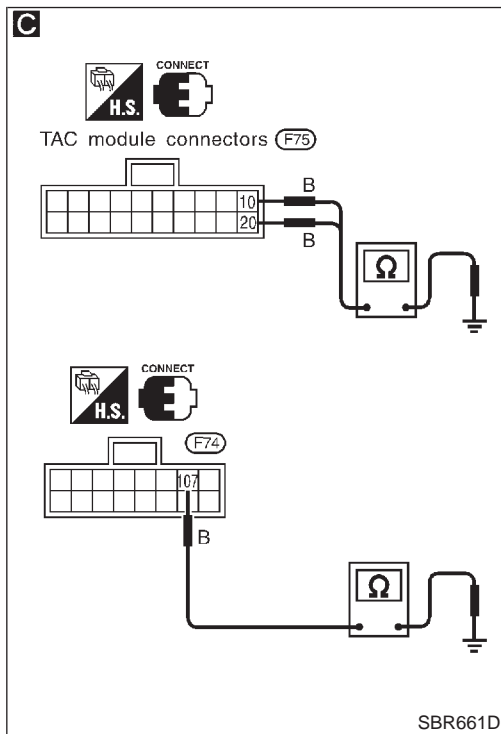

C CONTROL UNIT GROUND CHECK

Check continuity between terminals ⑩, ⑳, ⑩⑦ and ground.
Continuity should exist.

Check TAC module pin terminals for damage or the connection of TAC module harness connector.
 Reconnect TAC module harness connector. Then retest.

Check 10A fuse ⑳. Refer to POWER SUPPLY ROUTING in EL section.

Diagnostic Procedure 13 (Power supply and ground circuit for TAC module) (Cont'd)

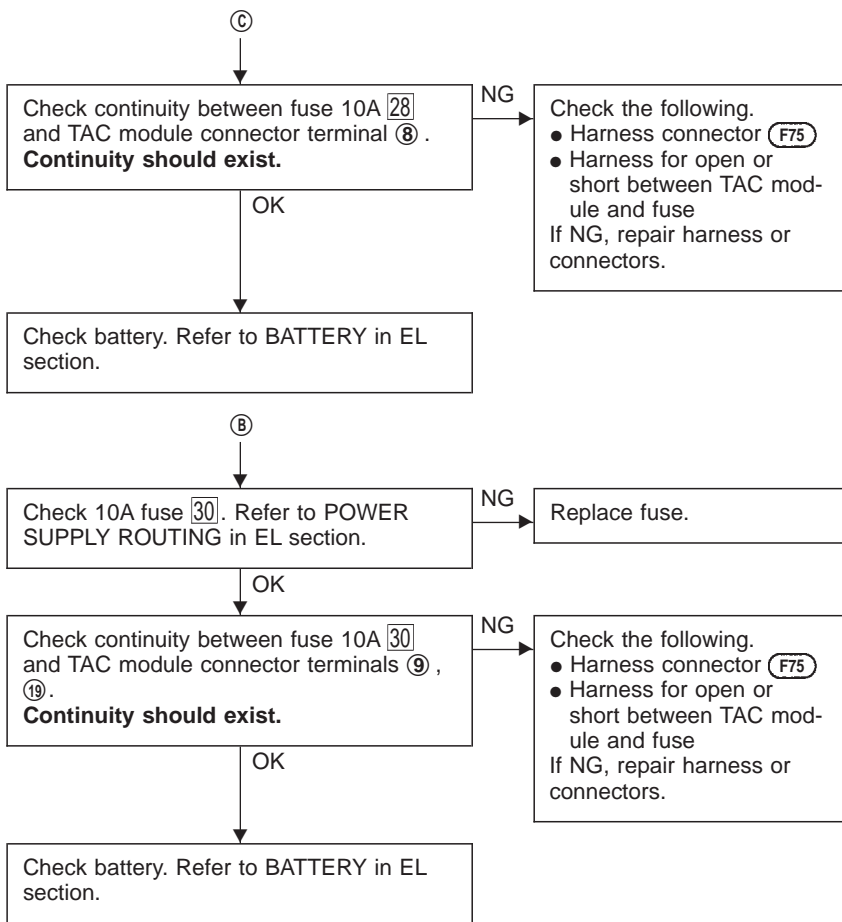

GI
MA
EM
LC
EC
FE
AT
PD
FA
RA
BR
ST
RS
BT
HA
EL
IDX

BR

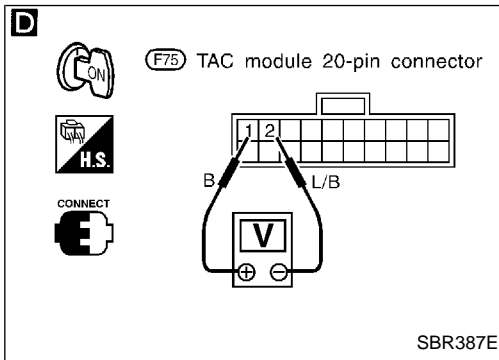
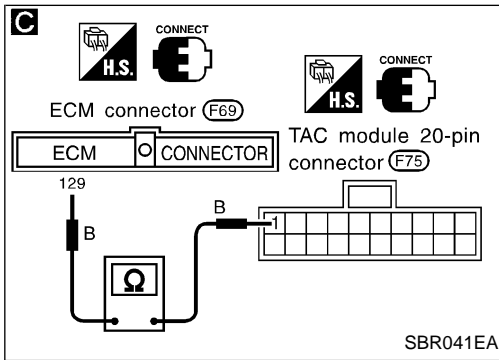
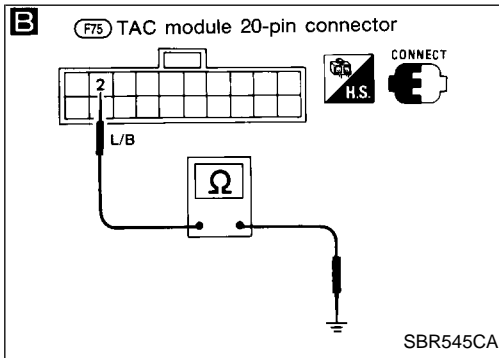
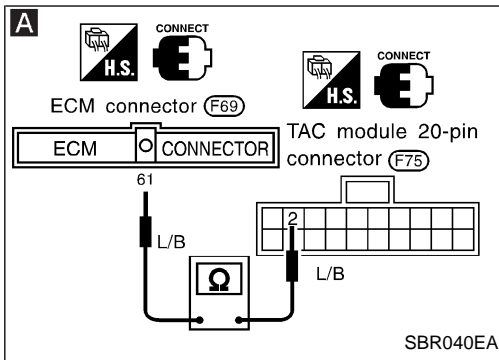

Diagnostic Procedure 14 (THROTTLE POSITION: Throttle position sensor signal input circuit)

Code No. 11 of TAC module

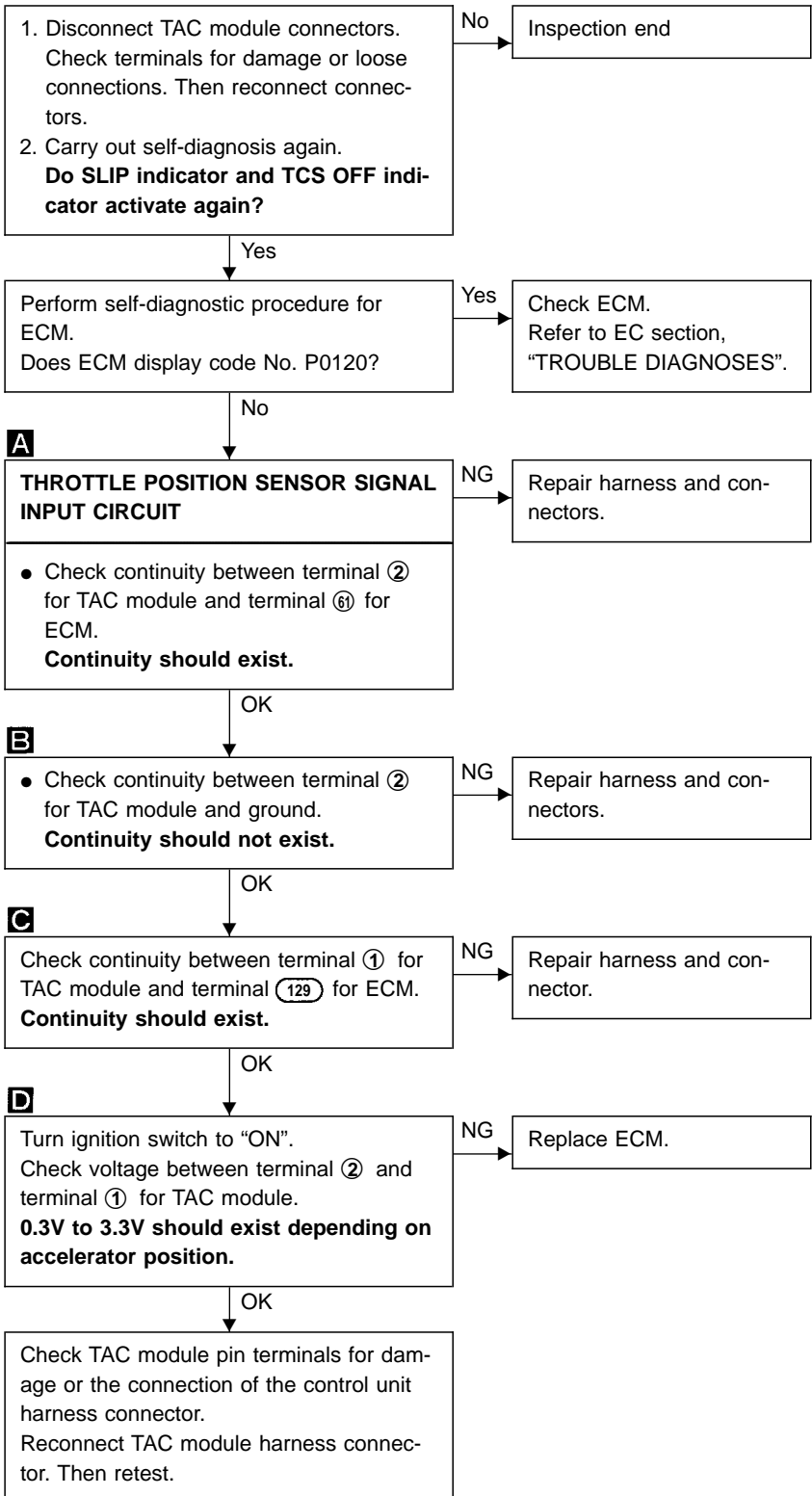

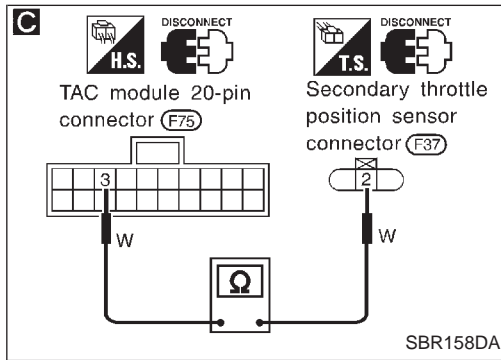
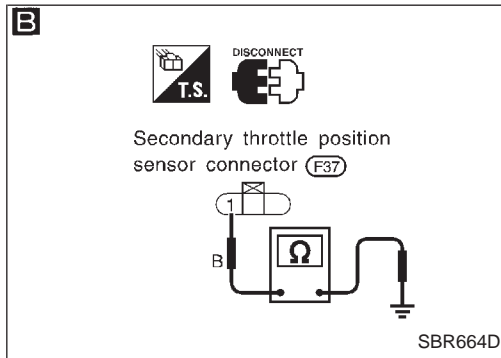
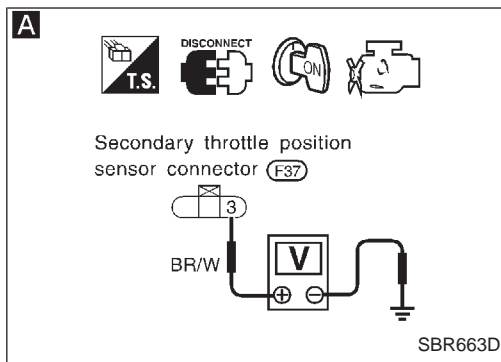

Diagnostic Procedure 15 (THROTTLE POSI SEN2: Secondary throttle position signal input circuit)

Code No. 12 of TAC module

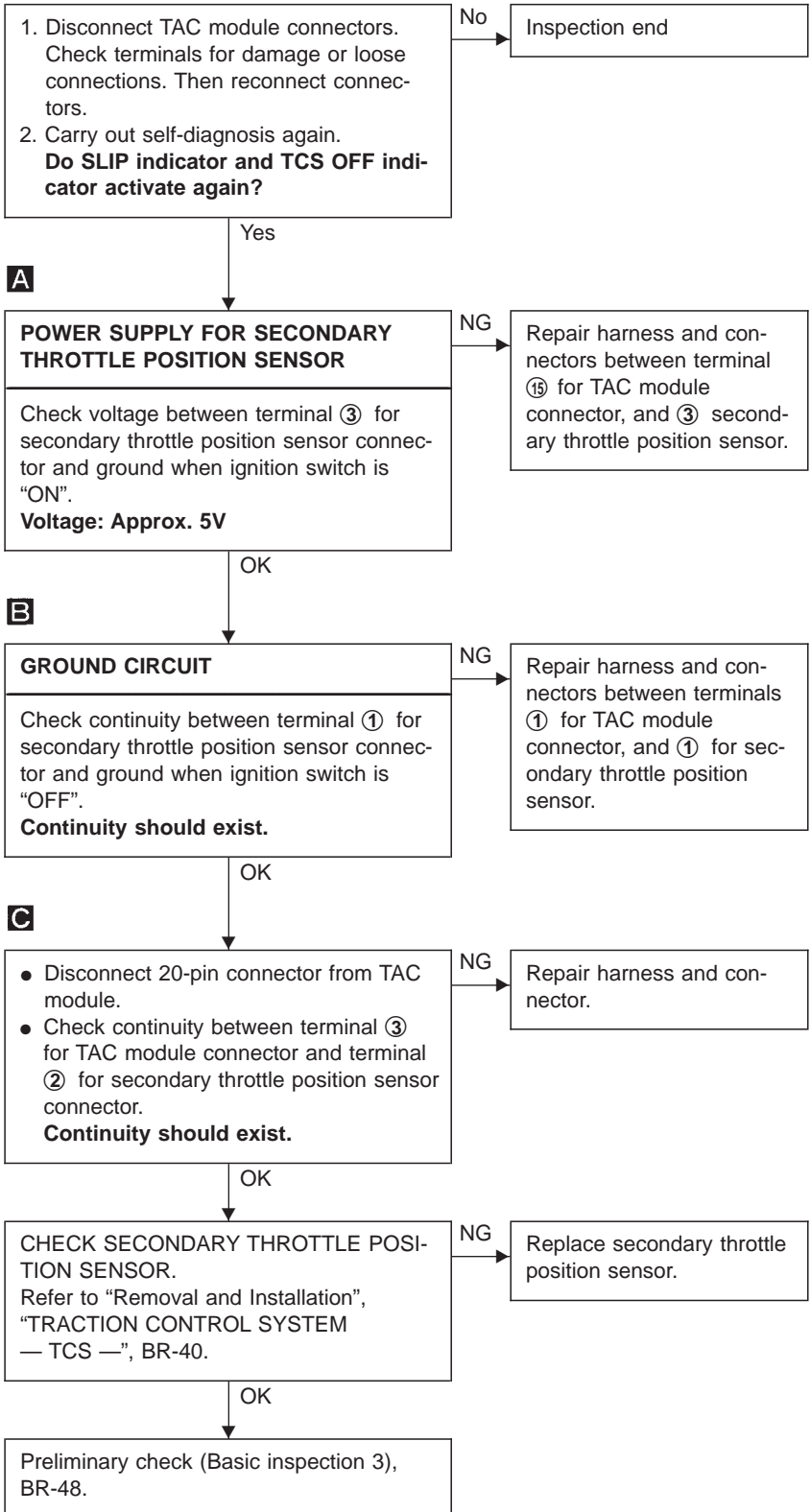

GI
MA
EM
LC
EC
FE
AT
PD
FA
RA
BR
ST
RS
BT
HA
EL
IDX

TROUBLE DIAGNOSES FOR SELF-DIAGNOSTIC ITEMS

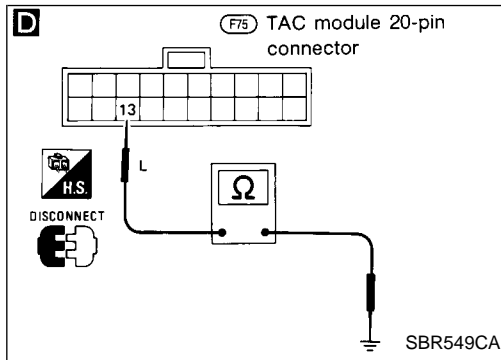
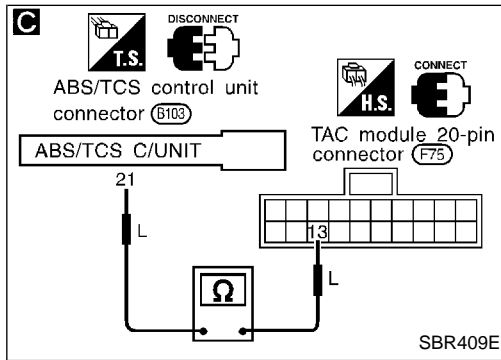
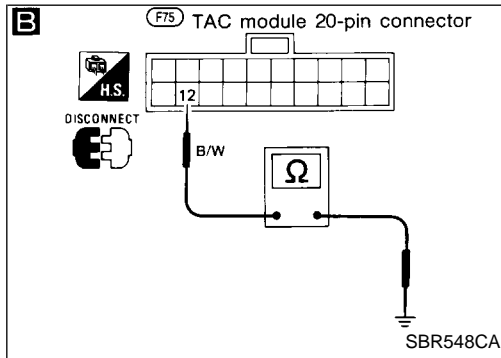
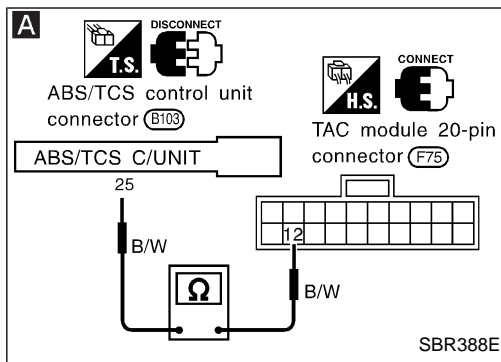

Diagnostic Procedure 16 (THRTL POS/S-2 SIG: Secondary throttle valve operating signal circuit and throttle valve opening signal circuit)

Code No. 58 of ABS/TCS control unit
Code No. 13 of TAC module

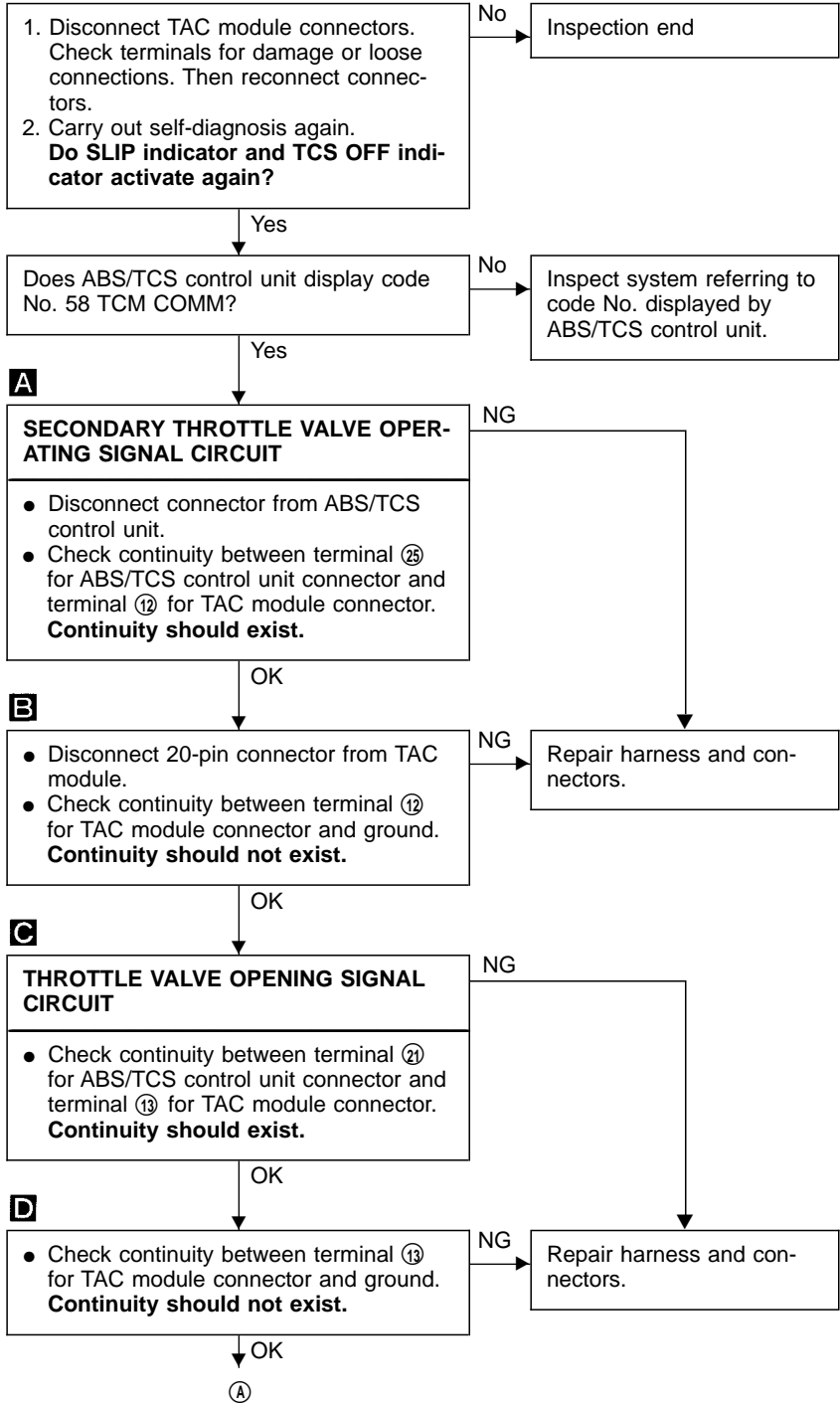

**Diagnostic Procedure 16 (THRTL POS/S-2 SIG:
Secondary throttle valve operating signal
circuit and throttle valve opening signal circuit)
(Cont'd)**

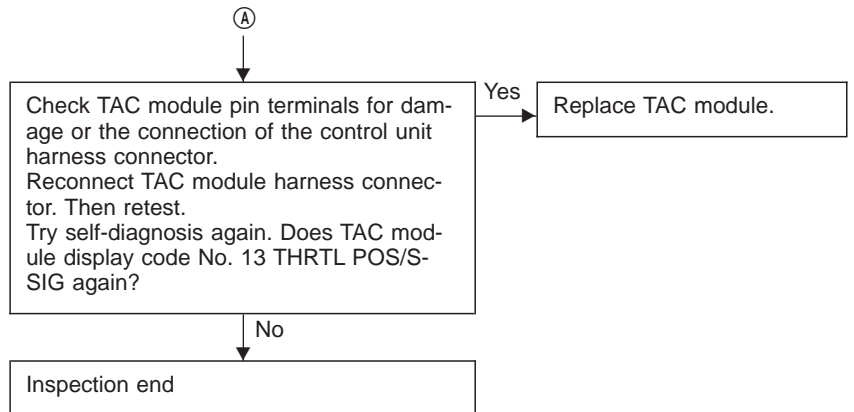

GI

MA

EM

LC

EC

FE

AT

PD

FA

RA

BR

ST

RS

BT

HA

EL

IDX

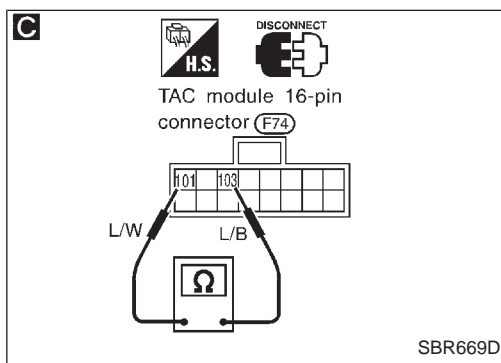
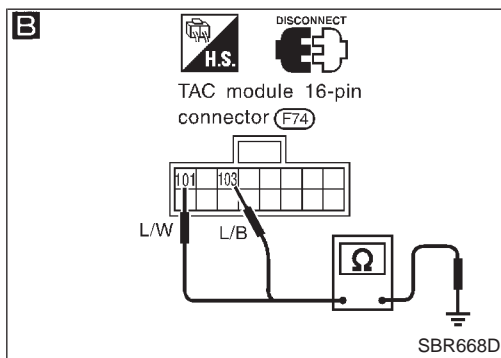
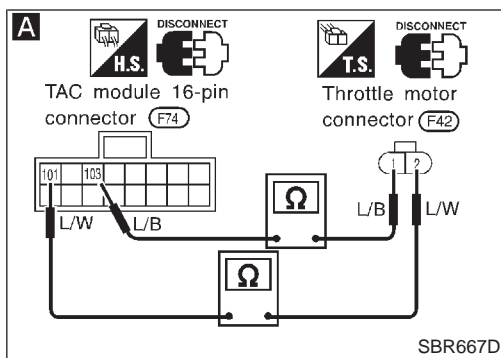

Diagnostic Procedure 17 (THROTTLE ACTUATOR/THROTTLE MOTOR: Throttle motor circuit)

Code No. 21 and 22 of TAC module

1. Disconnect TAC module connectors. Check terminals for damage or loose connections. Then reconnect connectors.
2. Carry out self-diagnosis again. **Do SLIP indicator and TCS OFF indicator activate again?**

No → Inspection end

Yes

A

- Disconnect 16-pin connector from TAC module and connector from throttle motor.
- Check continuity.

TAC module	Motor
101	2
103	1

Continuity should exist.

NG → Repair harness and connectors.

OK

B

THROTTLE MOTOR CIRCUIT FOR SHORT

- Check continuity between terminals 101, 103 for TAC module connector and ground. **Continuity should not exist.**

NG → Repair harness and connectors.

OK

C

- Disconnect connector from throttle motor.
- Check continuity between terminals 101 and 103 for TAC module connector. **Continuity should not exist.**

NG → Repair harness and connectors.

OK

CHECK THROTTLE MOTOR. Refer to THROTTLE MOTOR in Electrical Component Inspection, BR-127.

NG → Replace throttle motor.

OK

Preliminary Check (Basic inspection 3), BR-48

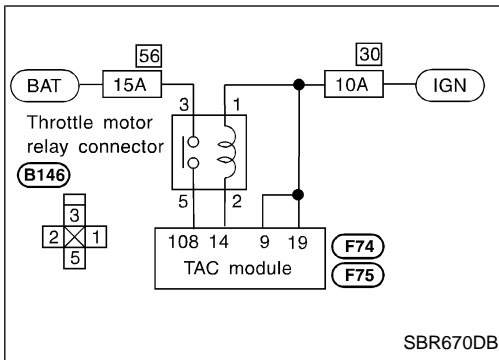

Diagnostic Procedure 18 (THROTTLE MOTOR RLY [SHORT] (-a)/THROTTLE MOTOR RLY [OPEN] (-b): Throttle motor relay circuit for open circuit and short circuit)

Code No. 23 and 24 of TAC module

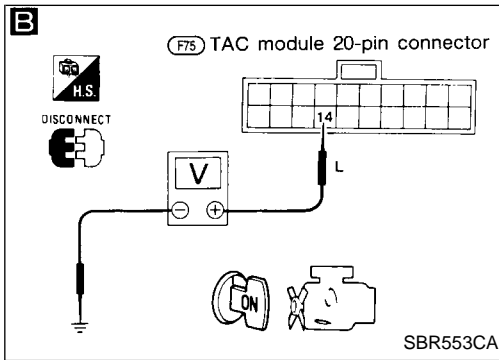
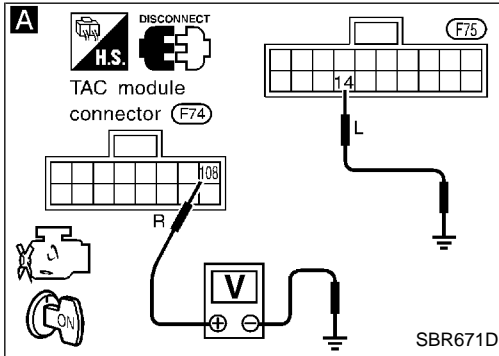

THROTTLE MOTOR RELAY POWER SUPPLY CHECK

Check 15A fuse 56. For fuse layout, refer to POWER SUPPLY ROUTING in EL section.

NG → (A) (Go to next page.)

OK

Check 10A fuse 30. For fuse layout, refer to POWER SUPPLY ROUTING in EL section.

NG → (B) (Skip page.)

OK

1. Disconnect TAC module connector. Check terminals for damage or loose connection. Then reconnect connectors. Then reconnect connectors.

2. Carry out self-diagnosis again. **Do SLIP indicator and TCS OFF indicator activate again?**

No → Inspection end

Yes

A

THROTTLE MOTOR RELAY CIRCUIT

- Disconnect connectors from TAC module.
- Turn ignition switch ON.
- Check voltage between the following terminals by grounding terminal 14.

TAC module	Motor
108	Ground

Battery voltage should exist.

OK → Preliminary check (Basic inspection 3), BR-48

NG

B

Check voltage between terminal 14 for TAC module connector and ground. **Battery voltage should exist.**

OK → (D) (Skip page.)

NG

(C)

GI
MA
EM
LC
EC
FE
AT
PD
FA
RA
BR
ST
RS
BT
HA
EL
IDX

TROUBLE DIAGNOSES FOR SELF-DIAGNOSTIC ITEMS

Diagnostic Procedure 18 (THROTTLE MOTOR RLY [SHORT] (-a)/THROTTLE MOTOR RLY [OPEN] (-b): Throttle motor relay circuit for open circuit and short circuit) (Cont'd)

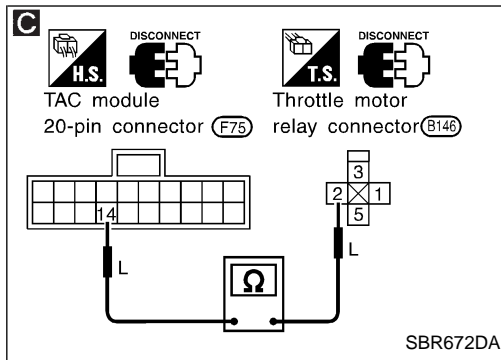

③

CHECK THROTTLE MOTOR RELAY.

- Remove battery.
- Remove throttle motor relay.
- Refer to THROTTLE MOTOR RELAY in Electrical Component Inspection, BR-126.

NG → Replace throttle motor relay.

④

C

- Check continuity between terminal ④ for TAC module connector and terminal ② for throttle motor relay connector. **Continuity should exist.**

NG → Check the following.

- Harness connectors (F75, B146)
- Harness for open or short between throttle motor relay connectors and TAC module

If NG, repair harness or connectors.

OK

Repair harness and connector between terminal ① for throttle motor relay connector and right side terminal of fuse No. 30 in fuse box.

For fuse layout, refer to EL section, "POWER SUPPLY ROUTING".

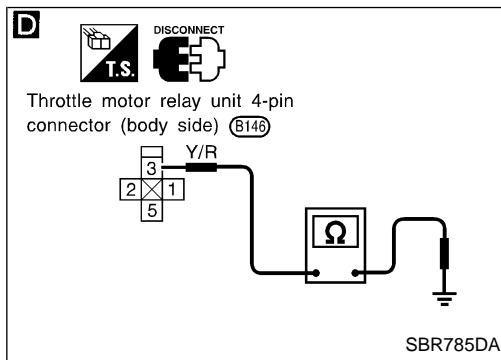

⑤

A

Replace fusible link.

Does the fusible link blow out?

No → Inspection end

Yes →

D

RELAY UNIT POWER SUPPLY CIRCUIT

- Disconnect throttle motor relay unit 4-pin connector (B146).
- Check continuity between throttle motor relay unit 4-pin connector (B146) (body side) terminal ③ and ground. **Continuity should not exist.**

NG → Check the following.

- Harness connector (B146)
- Harness for open or short between throttle motor relay unit and fuse

If NG, repair harness or connectors.

OK

Inspection end

TROUBLE DIAGNOSES FOR SELF-DIAGNOSTIC ITEMS

Diagnostic Procedure 18 (THROTTLE MOTOR RLY [SHORT] (-a)/THROTTLE MOTOR RLY [OPEN] (-b): Throttle motor relay circuit for open circuit and short circuit) (Cont'd)

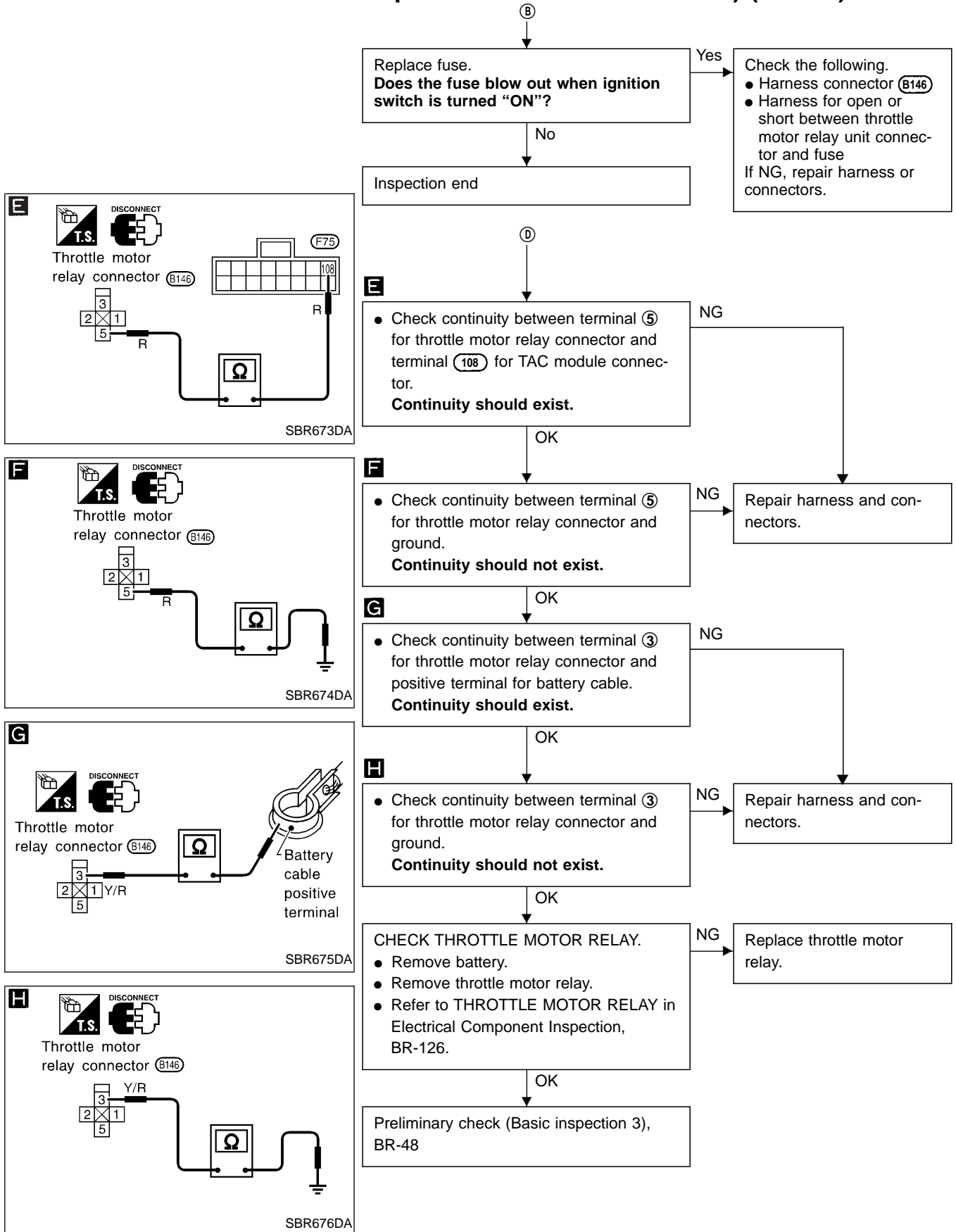

GI
MA
EM
LC
EC
FE
AT
PD
FA
RA
BR
ST
RS
BT
HA
EL
IDX

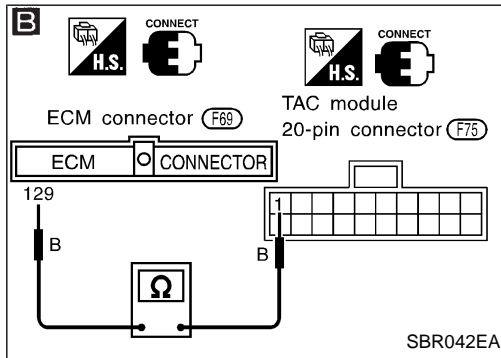
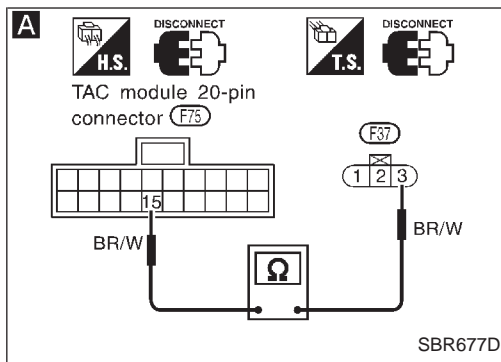

Diagnostic Procedure 19 (TH P/S PWR SUPPLY: Power supply circuit for sensor)

Code No. 34 of TAC module

A

- Disconnect 20-pin connector from TAC module.
 - Disconnect connector from secondary throttle sensor.
 - Check continuity between terminal ⑮ for TAC module connector and terminal ③ for secondary throttle position sensor connector.
- Continuity should exist.**

NG

Repair harness and connectors.

OK

B

- Check continuity between terminals ① for TAC module and terminal ⑫⑨ for ECM.
- Continuity should exist.**

NG

Repair harness and connectors.

OK

- Check continuity between terminals ① for TAC module and terminal ① for secondary throttle position sensor.
- Continuity should exist.**

NG

Repair harness and connectors.

OK

Preliminary check (Basic inspection 3), BR-48

Diagnostic Procedure 20 (THRTL/V RETURN SPR: Secondary throttle return spring)

Code No. 32 of TAC module

Erase self-diagnosis results from TAC module memory.
TRY SELF-DIAGNOSIS AGAIN.
Does CONSULT-II display "THRTL/V RETURN SPR" (TAC module code No. 32) again?

No

Inspect system again referring displayed code No.

Yes

Be sure to remove motor connector before inspection.
Completely close throttle valve, then open it. If throttle valve does not open completely, return spring may be broken. Replace throttle chamber with new one.

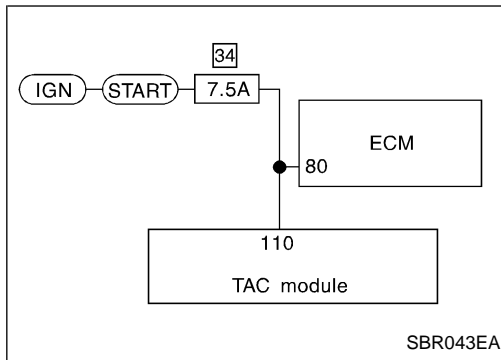

Diagnostic Procedure 21 (ENGINE START SIG: Start signal circuit)

Code No. 31 of TAC module

START SIGNAL POWER SUPPLY CHECK

Check 7.5A fuse 34. For fuse layout, refer to POWER SUPPLY ROUTING in EL section.

NG → (A) (See below.)

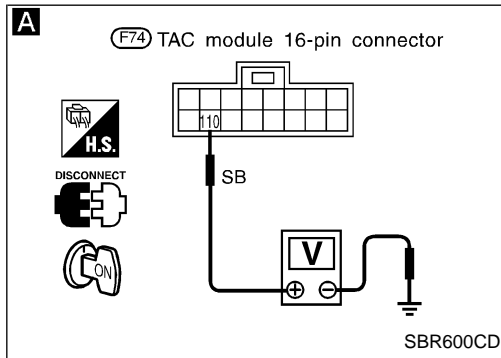

1. Disconnect connectors from TAC module. Check terminals for damage or loose connection. Then reconnect connectors.

2. Carry out self-diagnosis again.
Do SLIP indicator and TCS OFF indicator activate again?

No → Inspection end

A

- Reconnect ECM connector.
- Turn ignition switch ON.
- Check voltage between terminal 110 for TAC module connector and ground.
Voltage: Approx. 12V

NG → Repair harness and connectors between terminal 110 for TAC module connector and 7.5A fuse 34.

OK → Preliminary check (Basic inspection 3), BR-48

(A)

Replace fuse.
Does the fuse blow out when ignition switch is turned "START"?

No → Inspection end

Yes → Check the following.

- Harness connector F74
- Harness for open or short between TAC module connector and fuse

If NG, repair harness or connectors.

- GI
- MA
- EM
- LC
- EC
- FE
- AT
- PD
- FA
- RA
- BR**
- ST
- RS
- BT
- HA
- EL
- IDX

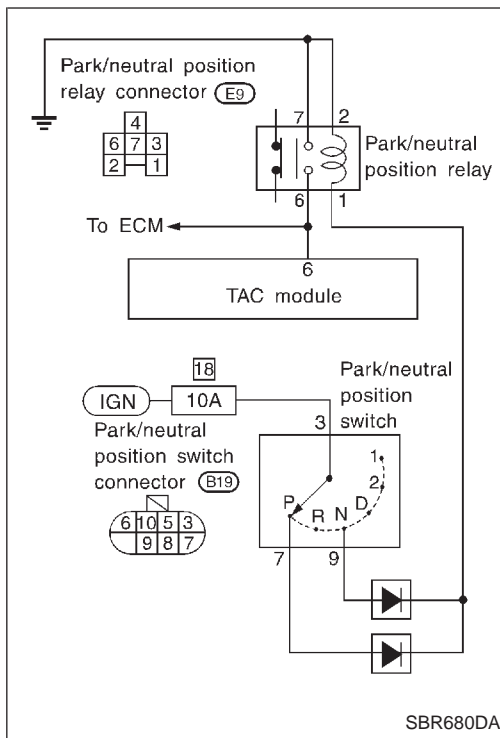

Diagnostic Procedure 22 (NEUTRAL POSI SW: Park/Neutral position (PNP) switch circuit)

Code No. 33 of TAC module

PNP SWITCH POWER SUPPLY CHECK NG → (A) (Go to next page.)

Check 10A fuse (F18). For fuse layout, refer to POWER SUPPLY ROUTING in EL section.

OK ↓

1. Disconnect connectors from TAC module. Check terminals for damage or loose connection. Then reconnect connectors.

2. Carry out self-diagnosis again.
Do SLIP indicator and TCS OFF indicator activate again?

No → Inspection end

Yes ↓

Does TAC module display code No. 33 still when shifting selector lever to all positions with ignition switch ON?

No → Inspection end

Yes ↓

(A)

- Disconnect 20-pin connector from TAC module.
- Turn ignition switch ON.
- Check continuity between terminal (6) and ground when shifting selector lever to all positions.
Continuity should exist when shifting to "P" and "N".
Continuity should not exist when shifting to other than "P" and "N".

OK → Inspection end

NG ↓

(B)

- Turn ignition switch OFF.
- Remove park/neutral position relay.
- Check continuity between terminal (6) for TAC module connector and terminal (6) for park/neutral position relay connector.
Continuity should exist.

NG → Repair harness and connectors.

OK ↓

Inspection end

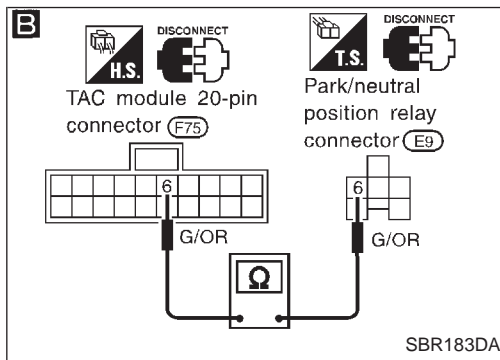
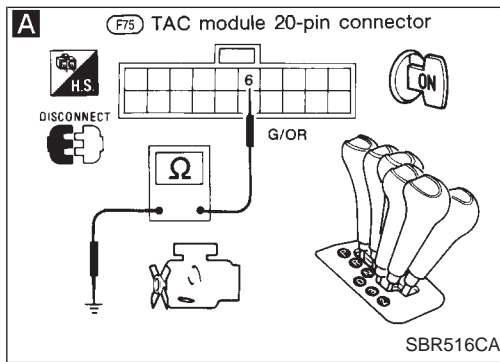

TROUBLE DIAGNOSES FOR SELF-DIAGNOSTIC ITEMS

Diagnostic Procedure 22 (NEUTRAL POSI SW: Park/Neutral position (PNP) switch circuit) (Cont'd)

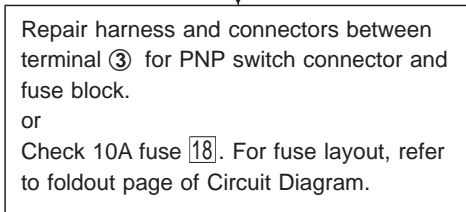
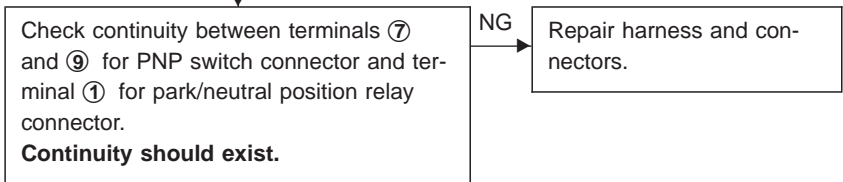
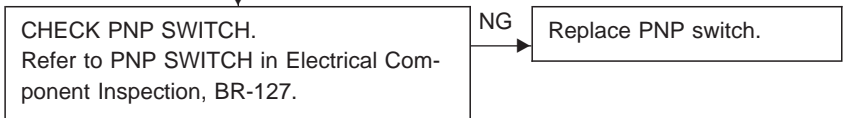
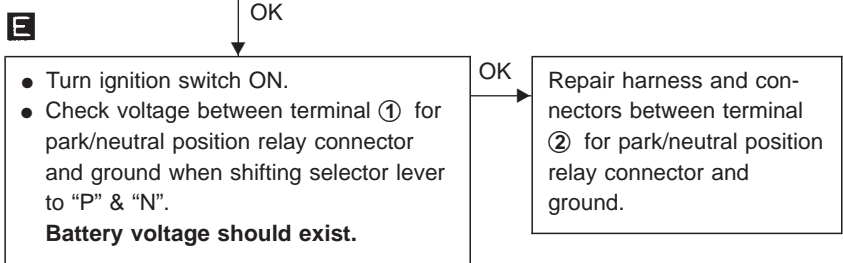
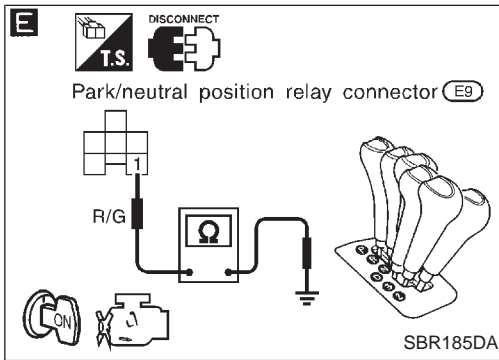
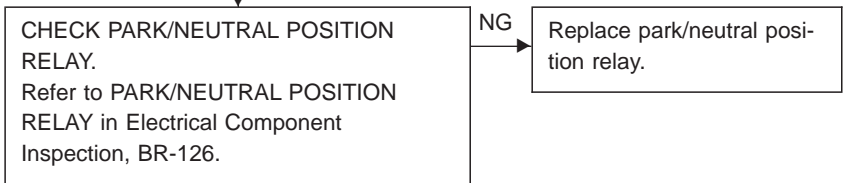
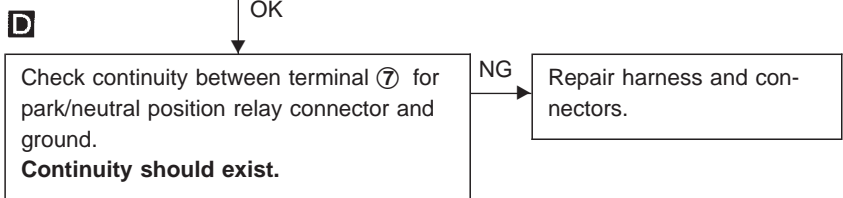
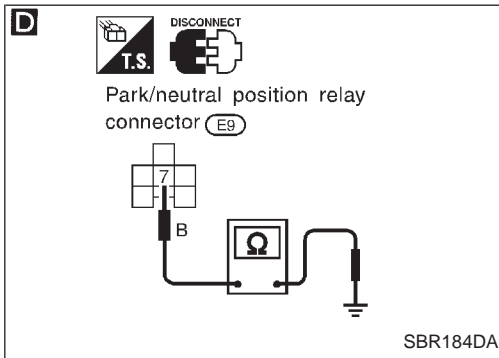
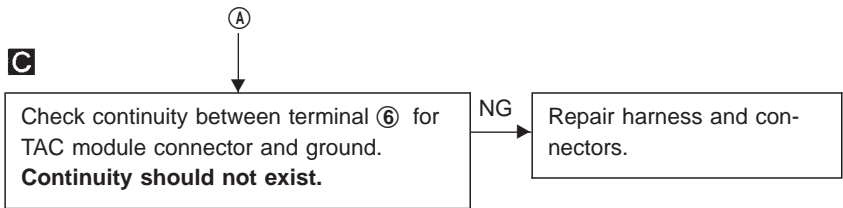
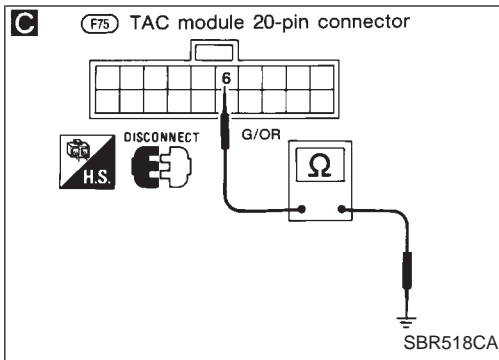

GI
MA
EM
LC
EC
FE
AT
PD
FA
RA
BR
ST
RS
BT
HA
EL
IDX

TROUBLE DIAGNOSES FOR SYMPTOMS

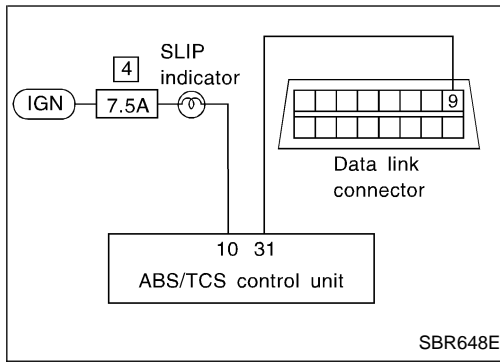

Diagnostic Procedure 23 (SLIP indicator does not come on when ignition switch is turned on.)

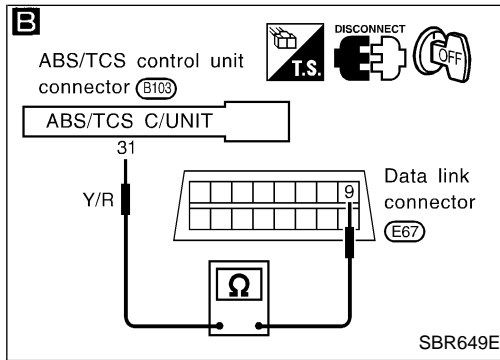
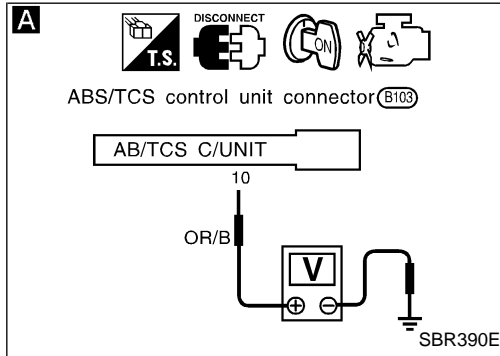
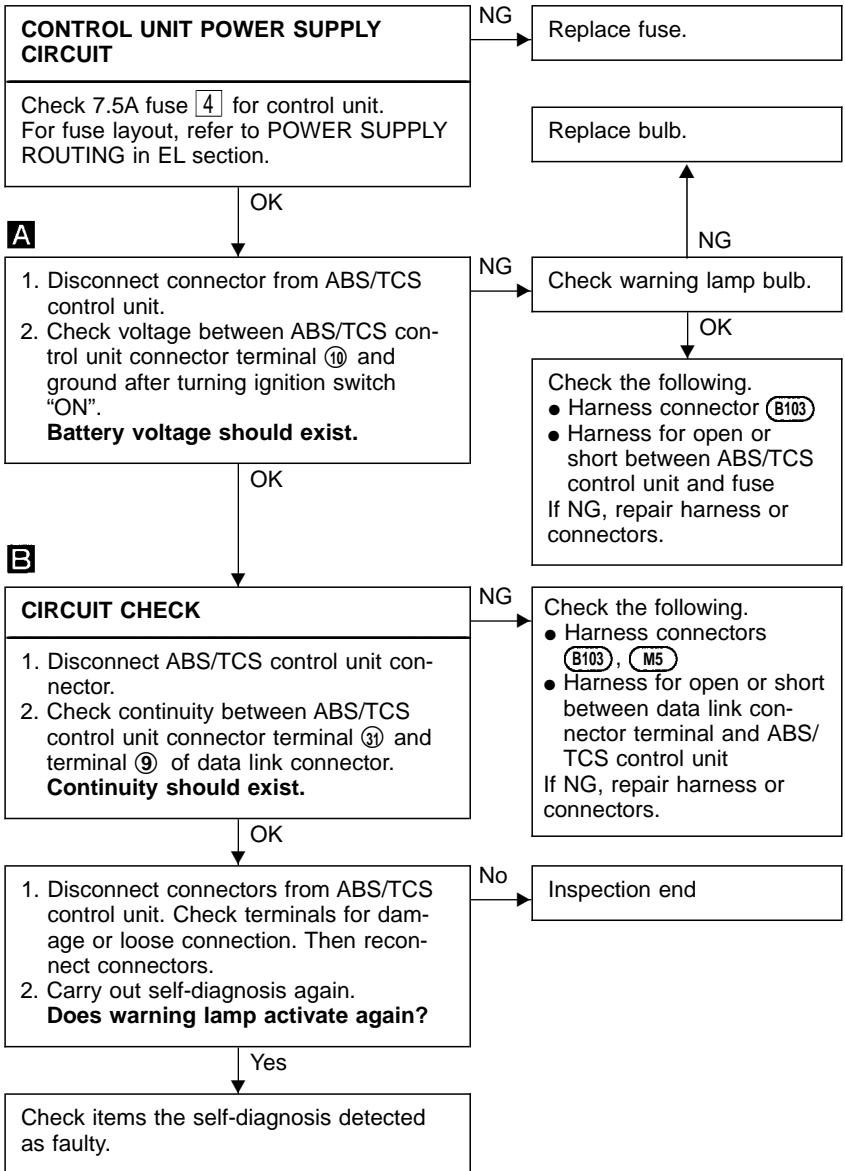

TROUBLE DIAGNOSES FOR SYMPTOMS

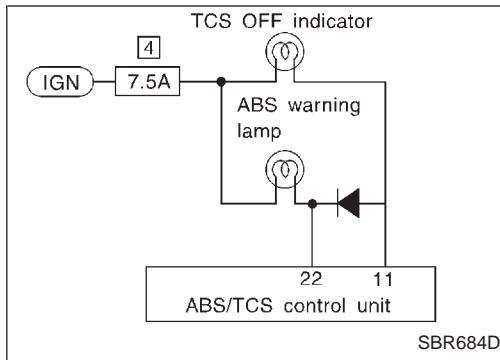

Diagnostic Procedure 24 (TCS OFF indicator does not come on when ignition switch is turned on.)

WARNING LAMP CIRCUIT CHECK

Check 7.5A fuse 4 for warning lamp. For fuse layout, refer to POWER SUPPLY ROUTING in EL section.

NG → Replace fuse.

OK ↓

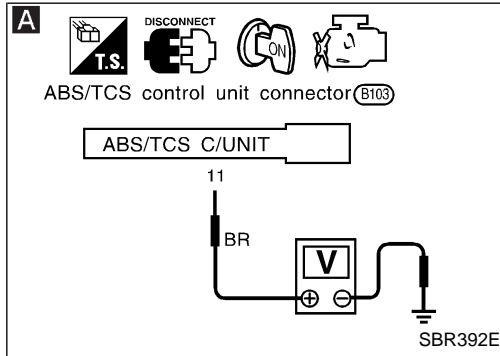

A

1. Install 7.5A fuse.
2. Disconnect connector from ABS/TCS control unit.
3. Check voltage between ABS/TCS control unit connector terminal ⑪ and ground after turning ignition switch "ON".

Battery voltage should exist after turning ignition switch "ON".

NG → Check warning lamp bulb.

OK ↓

Repair harness and connectors between fuse box and ABS/TCS control unit connector terminal ⑪ (including combination meter).

NG → Replace bulb.

1. Disconnect connectors from ABS/TCS control unit. Check terminals for damage or loose connection. Then reconnect connectors.
2. Carry out self-diagnosis again.

Does warning lamp activate again?

No → Inspection end

Yes ↓

Check items the self-diagnosis detected as faulty.

GI
MA
EM
LC
EC
FE
AT
PD
FA
RA
BR
ST
RS
BT
HA
EL
IDX

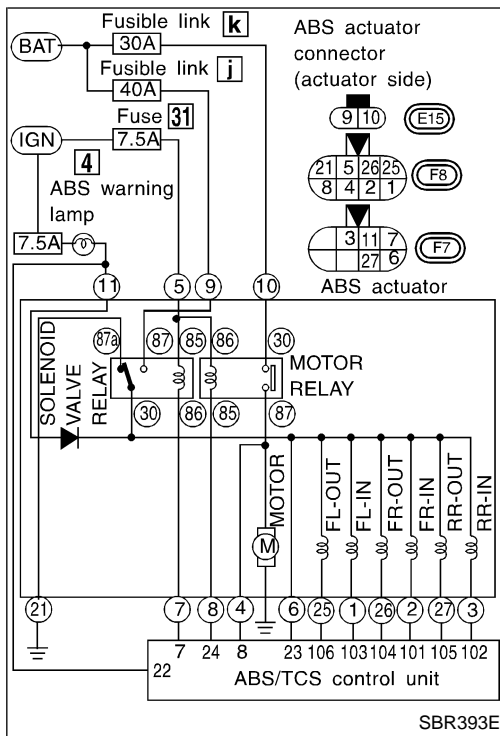

Diagnostic Procedure 25 (ABS warning lamp does not come on when ignition switch is turned on.)

WARNING LAMP CIRCUIT CHECK

NG → Replace fuse.

OK →

Check 7.5A fuse [4] for warning lamp. For fuse layout, refer to POWER SUPPLY ROUTING in EL section.

A

1. Install 7.5A fuse.
2. Disconnect connectors from ABS/TCS control unit and actuator.
3. Check voltage between ABS/TCS control unit connector terminal ② and ground after turning ignition switch "ON".
Battery voltage should exist after turning ignition switch "ON".

NG → Check warning lamp bulb.
OK → Repair harness and connectors between fuse box and ABS/TCS control unit connector terminal ② (including combination meter).

Replace bulb.

B

1. Turn ignition switch "OFF".
Disconnect ABS actuator 8-pin connector.
2. Check continuity between ABS/TCS control unit connector terminal ② and ABS actuator 8-pin connector (body side) terminal ⑩.
Continuity should exist.

NG → Repair harness and connectors between ABS warning lamp (combination meter) and ABS actuator 8-pin connector (body side) terminal ⑩.

OK →

C

1. Disconnect ABS actuator 8-pin connector.
2. Check continuity between ABS actuator harness 8-pin connector (body side) terminal ② and body ground.
Continuity should exist.

NG → Repair harness and connectors.

OK →

(Go to next page.)

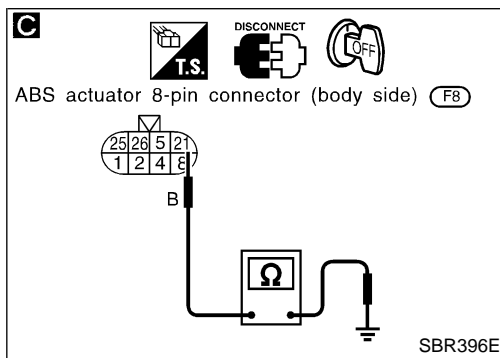
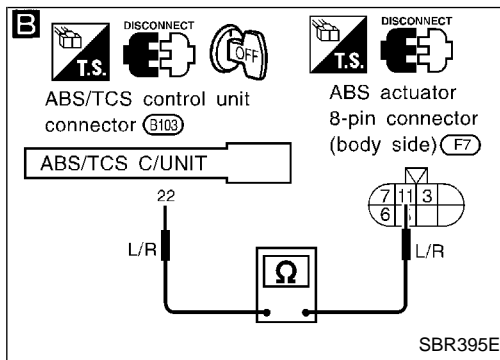
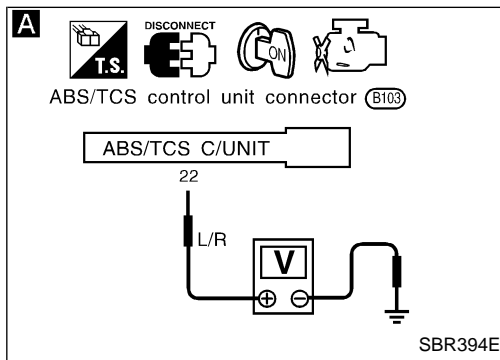

TROUBLE DIAGNOSES FOR SYMPTOMS

Diagnostic Procedure 25 (ABS warning lamp does not come on when ignition switch is turned on.) (Cont'd)

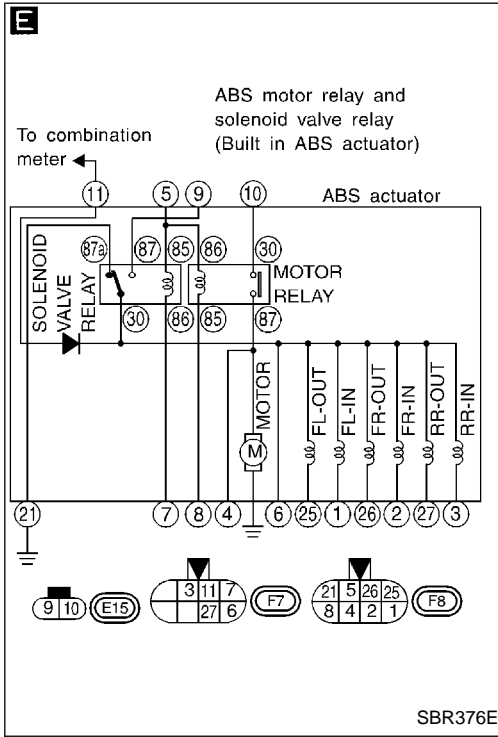
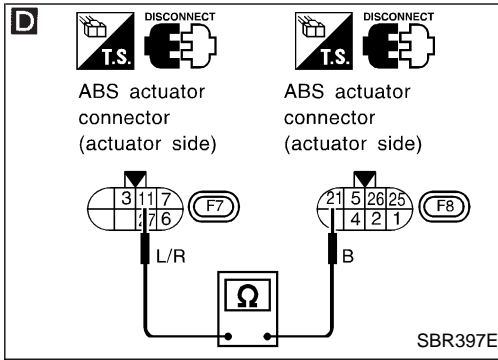

D

1. Disconnect ABS actuator 8-pin connector.
2. Check continuity between ABS actuator 8-pin connector (ABS actuator side) terminals ①⊖ and ②⊕.

Continuity should exist.
Note: Pay attention to tester polarity*.

NG → Replace ABS actuator.

OK →

CONTROL UNIT POWER SUPPLY CIRCUIT.

NG → Repair harness and connectors.

OK → Go to **A** in Diagnostic Procedure 26, BR-116.

E

CHECK SOLENOID VALVE RELAY.

NG → Replace ABS relay unit.

OK →

Relay type		Solenoid valve relay
Condition		Continuity existence between terminals ⑥ and ②
Battery voltage not applied between each terminal	⑤ and ⑦	Yes
Battery voltage applied between each terminal	⑤ and ⑦	No
Check resistance between each terminal	⑤ and ⑦	Approx. 100Ω

OK →

Go to Diagnostic Procedure 11, BR-96.

*: Specifications may vary depending on the type of tester. Before performing this inspection, refer to the instruction manual of the tester.

GI
MA
EM
LC
EC
FE
AT
PD
FA
RA
BR
ST
RS
BT
HA
EL
IDX

Diagnostic Procedure 26 (ABS warning lamp stays on when ignition switch is turned on.)

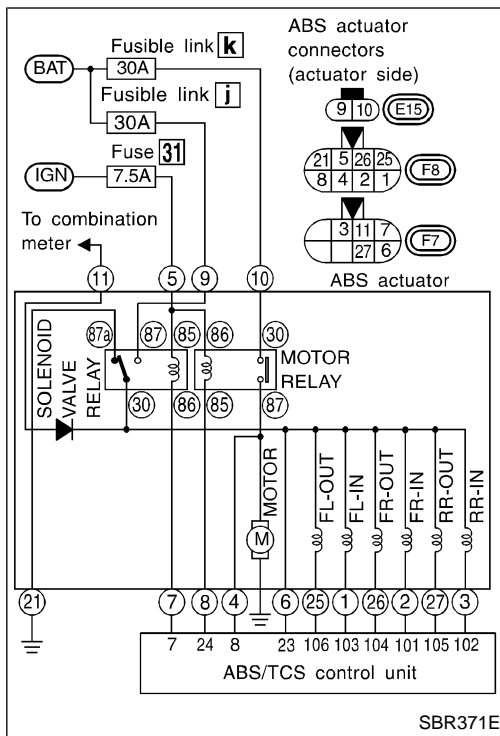

CONTROL UNIT POWER SUPPLY CIRCUIT

Check 7.5A fuse [31] for control unit. For fuse layout, refer to POWER SUPPLY ROUTING in EL section.

NG → (Skip page.)

A

1. Disconnect connector from ABS/TCS control unit.
2. Check voltage between ABS/TCS control unit connector terminal (108) and ground after turning ignition switch "ON".
Battery voltage should exist.

NG → Check the following.

- Harness connector (B103)
- Harness for open or short between control unit and fuse

If NG, repair harness or connectors.

B

SOLENOID VALVE RELAY COIL POWER SUPPLY CIRCUIT

1. Turn ignition switch "OFF". Disconnect ABS actuator 8-pin connector.
2. Check continuity between ABS/TCS control unit connector terminals and ABS actuator 8-pin connector (body side) terminals.

NG → Check the following.

- Harness connectors (B103, F7)
- Harness for open or short between actuator terminal (body side) and ABS/TCS control unit

If NG, repair harness or connectors.

ABS/TCS control unit	ABS actuator
(108)	(5)
(7)	(7)

Continuity should exist.

C

CIRCUIT CHECK

1. Disconnect ABS actuator 8-pin connector.
2. Check continuity between ABS actuator 8-pin connector (ABS actuator side) terminals (5) and (7).
Continuity should exist.

NG → Replace ABS actuator.

SOLENOID VALVE RELAY CHECK

Go to **E** in Diagnostic Procedure 25, BR-115.

NG → Replace ABS actuator.

OK → (Go to next page.)

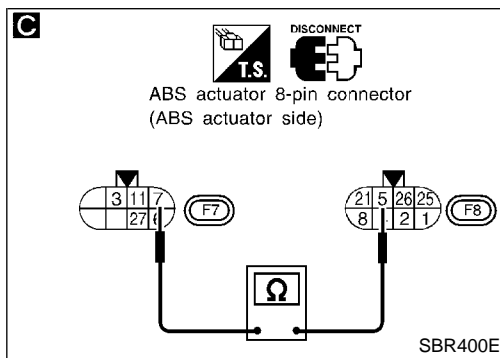
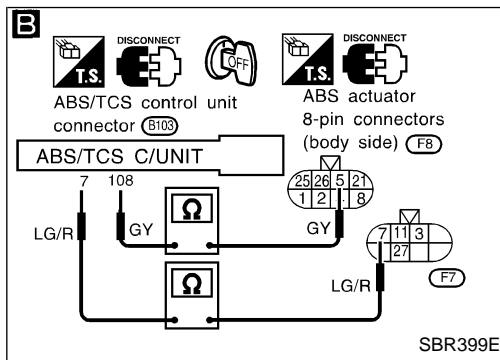
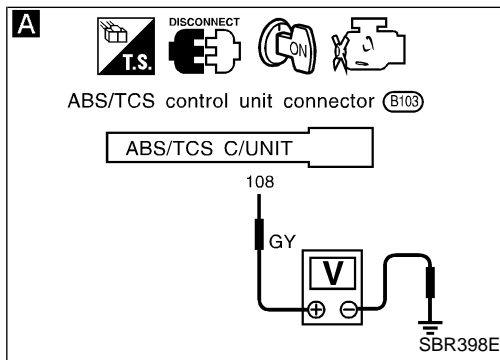

TROUBLE DIAGNOSES FOR SYMPTOMS

Diagnostic Procedure 26 (ABS warning lamp stays on when ignition switch is turned on.) (Cont'd)

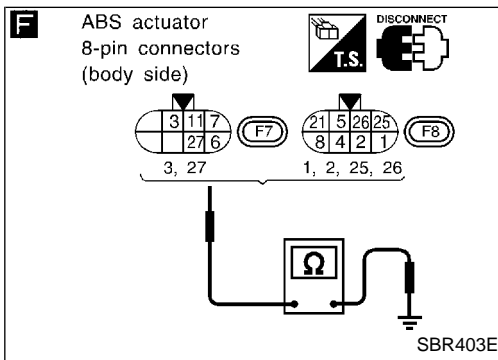
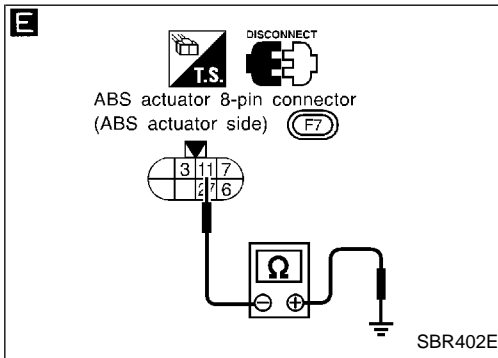
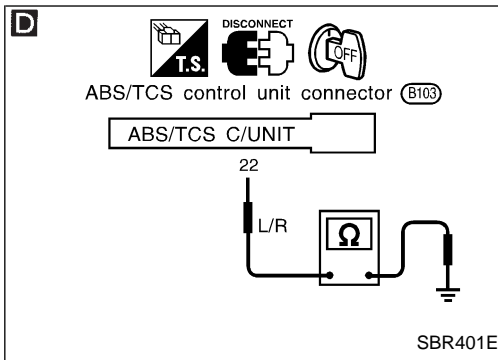

D

GROUND-SHORT CHECK FOR WARNING LAMP CIRCUIT.

1. Turn ignition switch "OFF".
2. Disconnect connectors from ABS/TCS control unit and ABS actuator 8-pin connector.
3. Check continuity between ABS/TCS control unit connector terminal ② and body ground.

Continuity should not exist.

NG

Check the following.

- Harness connector (B103)
- Harness for open or short between ABS/TCS control unit and fuse

If NG, repair harness or connectors.

OK

E

1. Disconnect actuator ground terminal and ABS actuator 8-pin connector.
2. Check continuity between ABS actuator 8-pin connector (ABS actuator side) terminal ⑪ and body ground.

Continuity should not exist.

Note: Pay attention to tester polarity*.

NG

Replace ABS actuator.

OK

F

SOLENOID VALVE CIRCUIT

1. Disconnect ABS actuator 6-pin connector.
2. Check continuity between each ABS actuator 8-pin connector (ABS actuator side) terminals and body ground.

Continuity should not exist.

NG

Replace ABS actuator.

OK

Check control unit pin terminals for damage or the connection of control unit harness connector.

Reconnect control unit harness connector.

Then retest.

*: Specifications may vary depending on the type of tester. Before performing this inspection, refer to the instruction manual of the tester.

GI
MA
EM
LC
EC
FE
AT
PD
FA
RA
BR
ST
RS
BT
HA
EL
IDX

TROUBLE DIAGNOSES FOR SYMPTOMS

Diagnostic Procedure 26 (ABS warning lamp stays on when ignition switch is turned on.) (Cont'd)

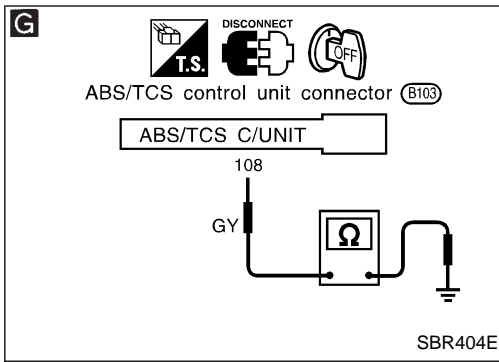

Ⓑ

Replace 7.5A 31 fuse.
Does the fuse blow out when ignition switch is turned "ON"?

No → Inspection end

Yes

Ⓒ

CONTROL UNIT POWER SUPPLY CIRCUIT

1. Disconnect control unit connector.
2. Check continuity between control unit connector terminal 108 and body ground.
Continuity should not exist.

NG → Check the following.
● Harness connector (B103)
● Harness for open or short between ABS/TCS control unit and fuse
If NG, repair harness or connectors.

OK

Check control unit pin terminals for damage or the connection of control unit harness connector.
Reconnect control unit harness connector.
Then retest.

TROUBLE DIAGNOSES FOR SYMPTOMS

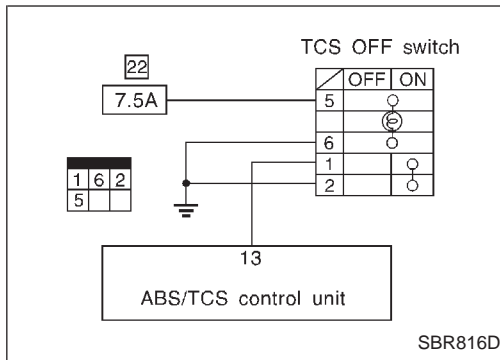

Diagnostic Procedure 27 (TCS OFF switch is inoperative.)

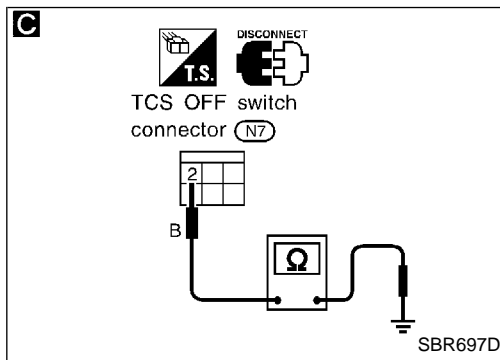
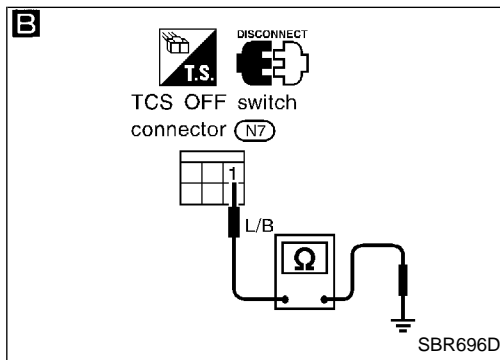
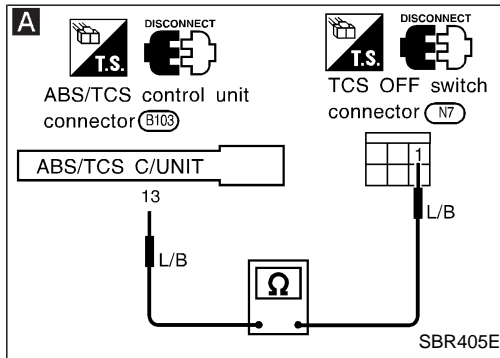
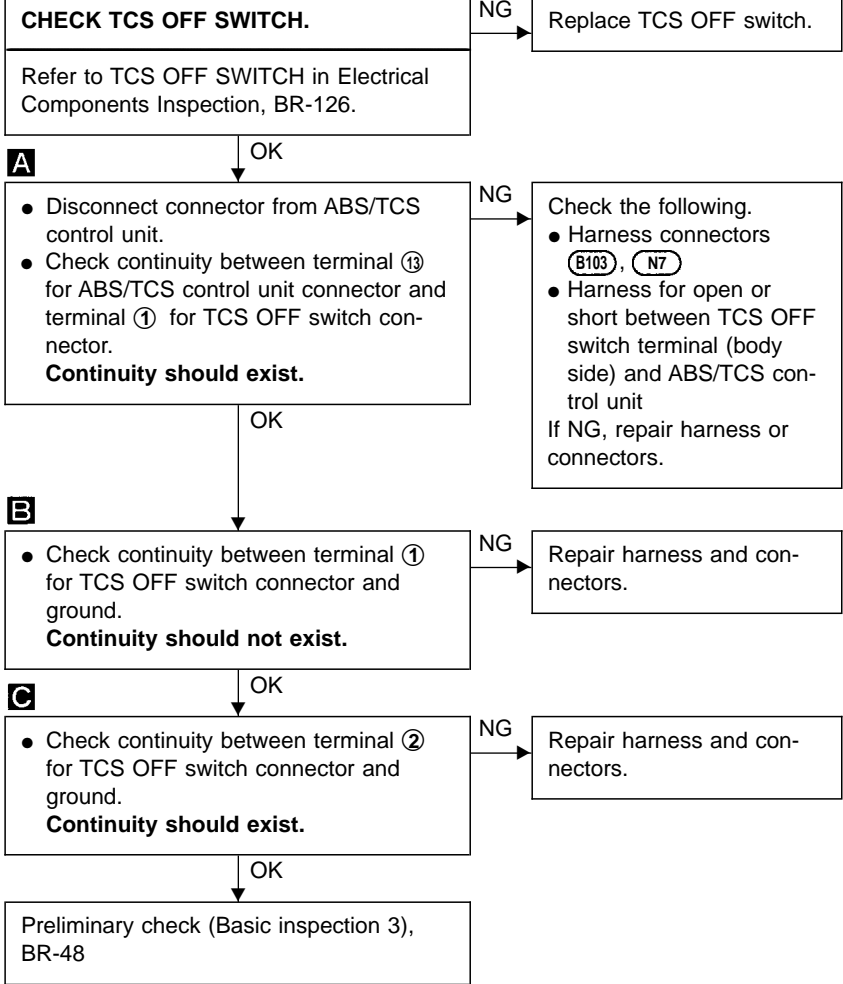

GI
MA
EM
LC
EC
FE
AT
PD
FA
RA
BR
ST
RS
BT
HA
EL
IDX

Diagnostic Procedure 28 (ABS works frequently.)

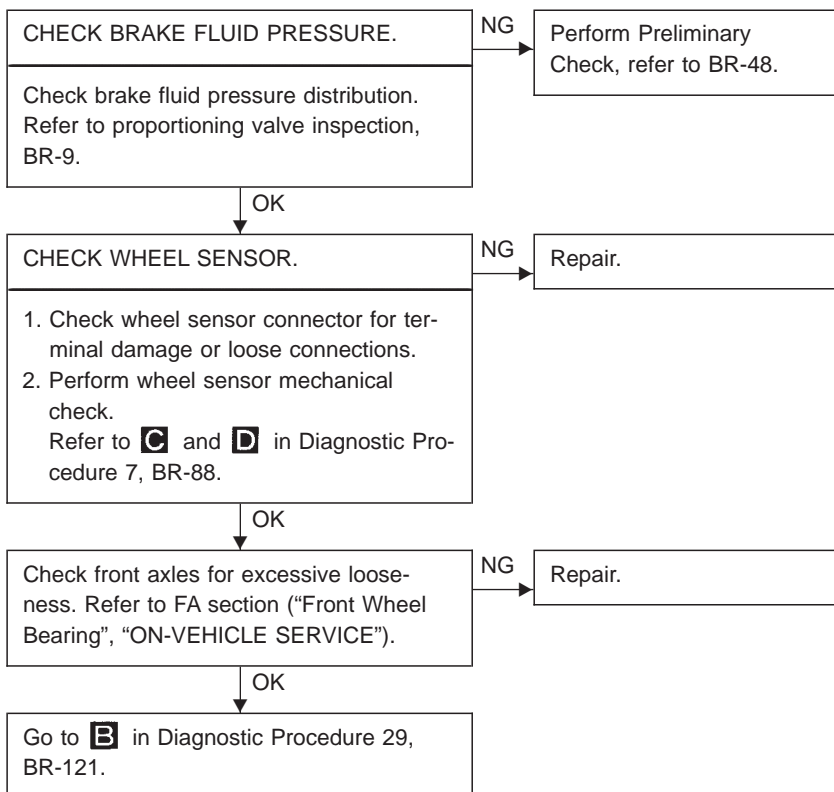

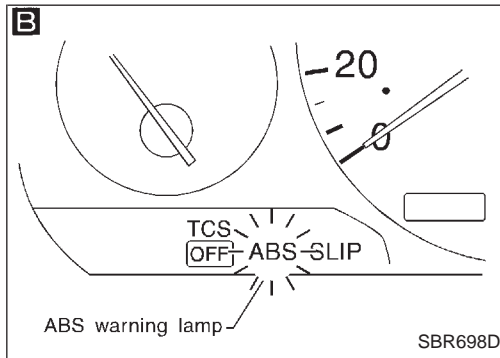
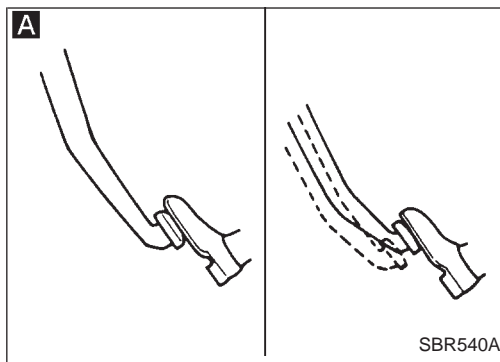

Diagnostic Procedure 29 (Unexpected pedal action)

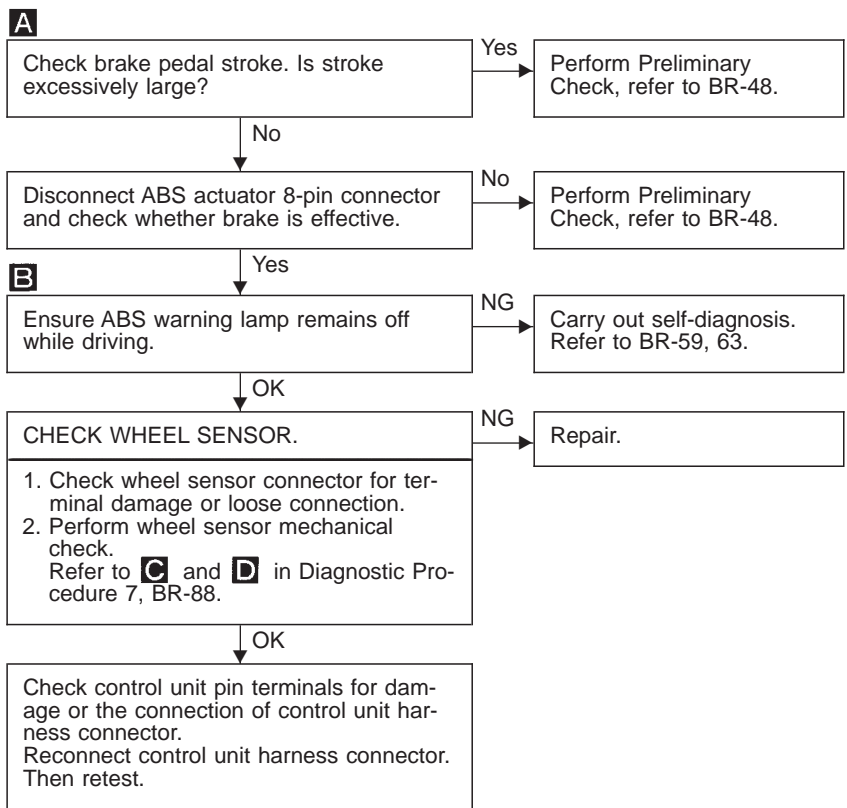

GI
MA
EM
LC
EC
FE
AT
PD
FA
RA

BR

Diagnostic Procedure 30 (Long stopping distance)

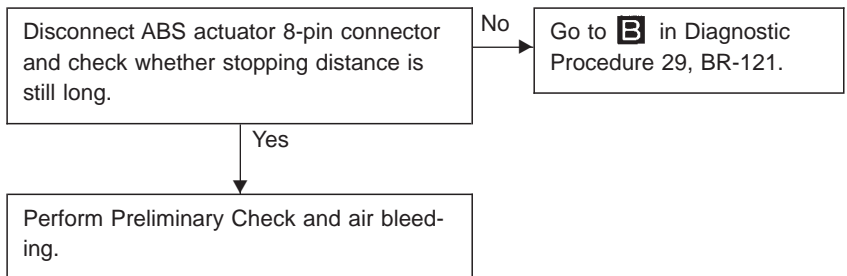

ST
RS
BT
HA
EL
IDX

Note: Stopping distance may be larger than vehicles without ABS when road condition is slippery.

Diagnostic Procedure 31 (ABS does not work.)

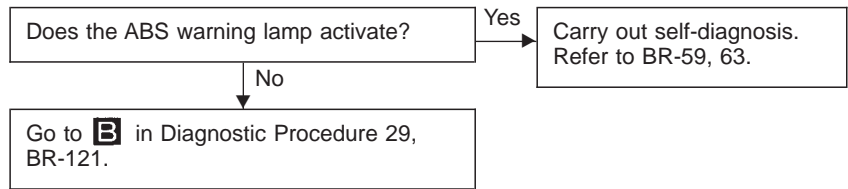

Note: ABS does not work when vehicle speed is under 10 km/h (6 MPH).

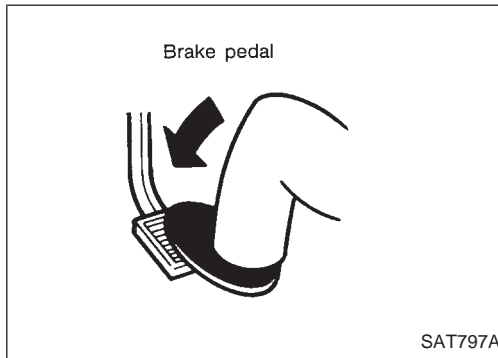

Diagnostic Procedure 32 (Pedal vibration and noise)

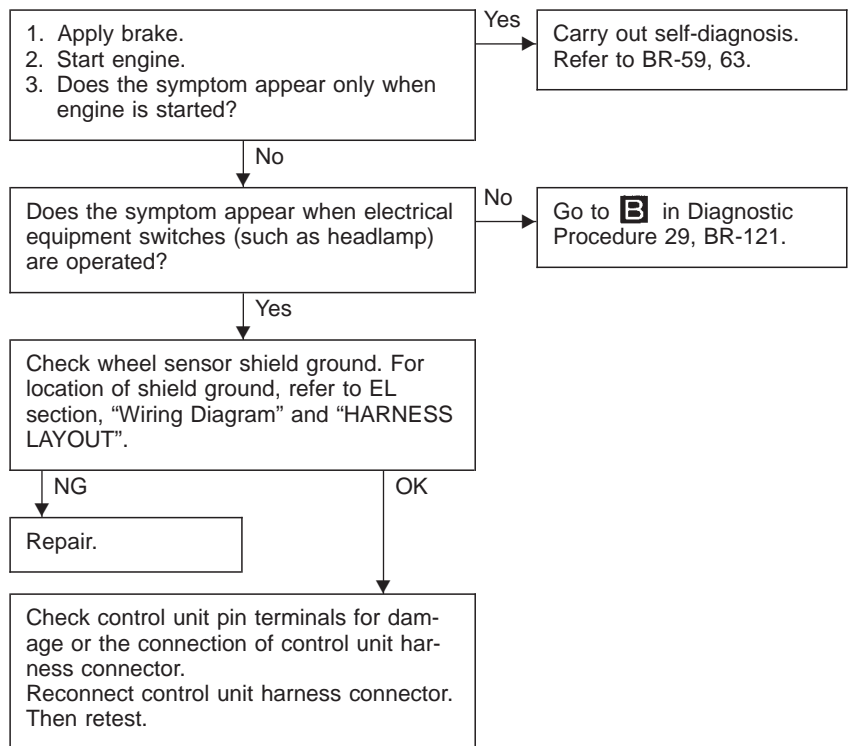

Note: ABS may operate and cause vibration under any of the following conditions.

- Applying brake gradually when shifting or operating clutch.
- Low friction (slippery) road.
- High speed cornering.
- Driving over bumps and pot holes.
- Engine speed is over 5,000 rpm with vehicle stopped.

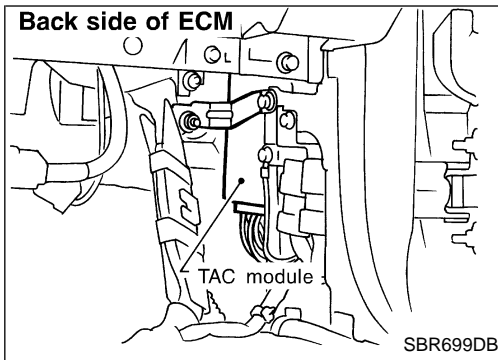

Electrical Component Inspection

INSPECTION OF ABS/TCS CONTROL UNIT

- Check that voltage between ABS/TCS control unit terminals is within the following reference value.

- Pin connector terminal layout.

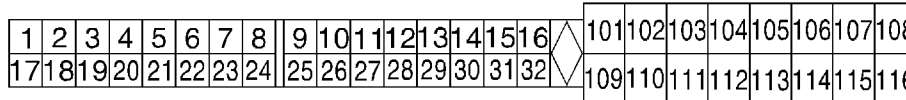

SBR406E

ABS/TCS control unit inspection table

TERMINAL NO.		ITEM	CONDITION	DATA (Reference value)
+	-			
108		Power source	Ignition switch "ON"	Battery voltage
6		Stop lamp switch signal	Brake pedal depressed	Approx. 12V
			Brake pedal released	Less than 2V
24		Motor relay	ABS actuator motor operating (Perform "ACTIVE TEST" mode with CONSULT-II.) Engine running	Less than 2V
			ABS actuator motor not operating	Approx. 12V
7		Actuator relay	ABS actuator relay operating (Engine is running.)	Less than 2V
			ABS actuator relay not operating (Ignition switch "ON")	Approx. 12V
23	Ground	Actuator monitor	ABS actuator relay operating (Engine is running.)	Approx. 12V
			ABS actuator relay not operating (Ignition switch "ON")	Approx. 0V
101		Front solenoid valve RH IN	ABS actuator operating (Perform "ACTIVE TEST" mode with CONSULT-II.) Engine running	Approx. 0V
102		Rear solenoid valve IN		
103		Front solenoid valve LH IN	ABS actuator not operating (Engine is running with vehicle stopped.)	Approx. 12V
8		Motor monitor	ABS actuator motor operating (Perform "ACTIVE TEST" mode with CONSULT-II.) Engine running	Approx. 12V
			ABS actuator motor not operating	Approx. 0V
22		ABS warning lamp	ABS warning lamp "ON"*1	Approx. 0V
			ABS warning lamp "OFF"*1	Approx. 12V

GI
 MA
 EM
 LC
 EC
 FE
 AT
 PD
 FA
 RA
BR
 ST
 RS
 BT
 HA
 EL
 IDX

TROUBLE DIAGNOSES FOR SYMPTOMS

Electrical Component Inspection (Cont'd)

TERMINAL NO.		ITEM	CONDITION	DATA (Reference value)
+	-			
1	17	Front wheel sensor RH	Wheel is rotating [Drive vehicle at 30 km/h (19 MPH).]*2	Approx. 0.1 - 0.2V Approx. 200 Hz*3
2	18	Rear wheel sensor RH		
4	20	Rear wheel sensor LH		
3	19	Front wheel sensor LH		Approx. 0.1 - 0.2V Approx. 200 Hz*3
14	Ground	Engine speed signal*4	Engine running at idle speed Engine running at 2,000 rpm	Approx. 2.5V Approx. 2.4V
104		Front solenoid valve RH OUT	ABS actuator operating (Perform "ACTIVE TEST" mode with CONSULT-II.) Engine running	Approx. 0V
105		Rear solenoid valve OUT		
106		Front solenoid valve LH OUT	ABS actuator not operating (Engine is running with vehicle stopped.)	Approx. 12V
13	Body ground	TCS OFF switch signal	TCS OFF switch pressed TCS OFF switch released	Approx. 0V Approx. 4 - 5V
11		TCS OFF indicator	TCS OFF indicator ON*5 TCS OFF indicator OFF	0V Approx. 12V (Power source voltage)
10		SLIP indicator	SLIP indicator ON*6 SLIP indicator OFF	0V Approx. 12V (Power source voltage)
21		Throttle valve opening rate signal	<p>Approx. 7V min. 0V 10 ms 80 ms SBR701D</p>	—
25	Secondary throttle valve opening rate target	<p>Approx. 7V min. 0V 10 ms 80 ms SBR701D</p>	—	
16	LAN signal	<p>Approx. 5V 0V 0.07 ms 2 ms SBR702D</p>	—	

NOTE:

*1: ABS warning lamp ON-OFF timing

ON - ignition switch "ON" (before engine starts) or when failure is sensed.

OFF - After engine starts (System in good operating condition)

*2: Inflate tires to specifications.

*3: Use oscilloscope checking, when pulse occurs.

*4: Refer to "ECM terminals and reference value" in EC section.

*5: TCS OFF indicator ON-OFF timing

ON - ignition switch "ON" (before engine starts) or failure is sensed (TCS OFF switch "ON")

OFF - After engine starts (System in good operating condition) and TCS OFF switch "OFF"

*6: SLIP indicator ON-OFF timing

ON - ignition switch "ON" (before engine starts) or TCS in operation

OFF - After engine starts and when TCS not operating

TROUBLE DIAGNOSES FOR TCS

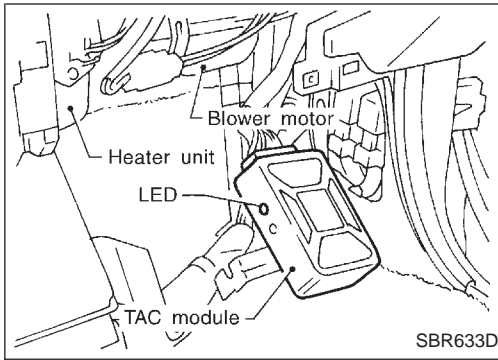

Electrical Component Inspection

INSPECTION OF TAC MODULE

- Check that voltage between TAC module terminals is within the following reference value.

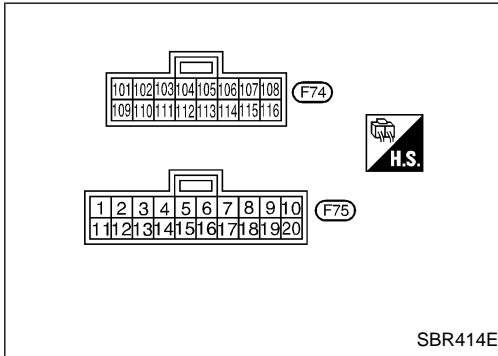

- Pin connector terminal layout.

TAC module inspection table for digital multimeter

*Data are reference values.

TERMINAL NO.	ITEM	CONDITION	*DATA
2	Throttle opening signal	Ignition switch "ON"	Approximately 0.4 - 3.1V Voltage varies with the throttle valve opening angle.
3	Secondary throttle position sensor	Vehicle is running	Approximately 0.5 - 4.1V Voltage varies with the secondary throttle valve opening angle.
4	Secondary throttle valve signal	Vehicle is running	Approximately 0.4 - 3.1V
7	TCS SW	Ignition switch "ON"	Approximately 10V
8	Power source	Ignition switch "ON"	Battery voltage
9			
19			
14	Throttle motor relay	Ignition switch "ON"	Approximately 1.5V
15	Power supply for sensor	Ignition switch "ON"	Approximately 5V
108	Throttle motor relay	Ignition switch "ON"	Approximately 12V
110	Engine start signal	Ignition switch "ON"	Approximately 12V

GI
MA
EM
LC
EC
FE
AT
PD
FA
RA
BR
ST
RS
BT
HA
EL
IDX

TROUBLE DIAGNOSES FOR TCS

Electrical Component Inspection (Cont'd)

TAC MODULE INSPECTION TABLE FOR CONSULT-II

Monitor item	Display representation	Condition	Standard value or indication	(Reference) Diagnostic Procedures (When measured voltage is outside specifications.)
THRTL POS SEN [V]	Sensor voltage [V]	Throttle valve fully-closed	Approx. 0.5V	14
THRTL POS SE2	Sensor voltage [V]	Idling	Approx. 3.4V	15
TH OPEN SIG	Motor throttle target position signal [ms]	TCS not operating	Approx. 9 ms	16
START SIGNAL	ON/OFF	Key switch "ON"	ON	21
NEUT POSI SW	ON/OFF	Switch in Park/Neutral	ON	22

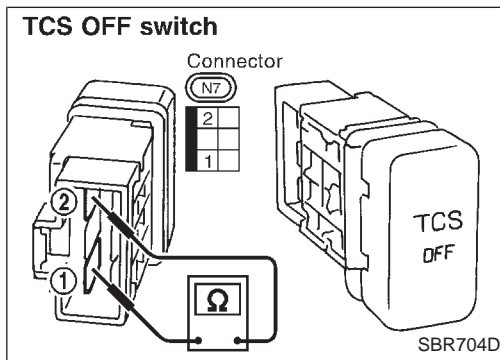

TCS OFF SWITCH

Check continuity between terminals as shown.

SWITCH condition	Continuity existence
Pushed	Yes
Released	No

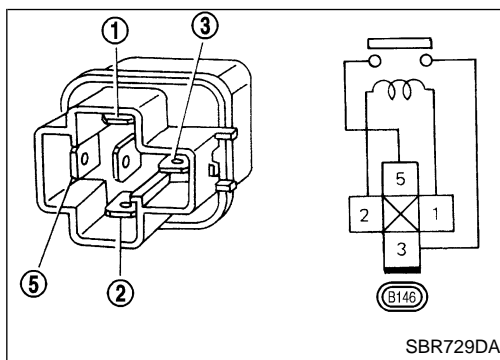

THROTTLE MOTOR RELAY

Condition	Continuity existence between terminals ③ and ⑤
Battery voltage not applied between terminals ① and ② .	No
Battery voltage applied between terminals ① and ② .	Yes

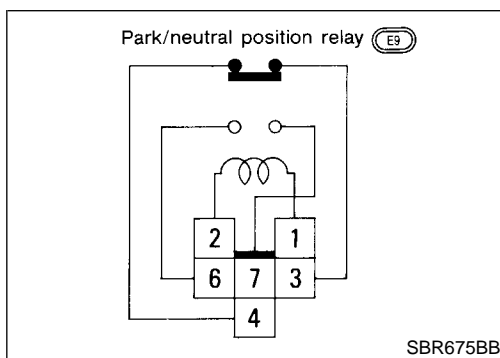

PARK/NEUTRAL POSITION RELAY

Check continuity between terminals ⑥ and ⑦ .

Condition	Continuity
12V direct current supply between terminals ① and ② .	Yes
No current supply	No

TROUBLE DIAGNOSES FOR TCS

Electrical Component Inspection (Cont'd)

PARK/NEUTRAL POSITION (PNP) SWITCH

Check continuity between terminals ③ and ⑦, ⑨.

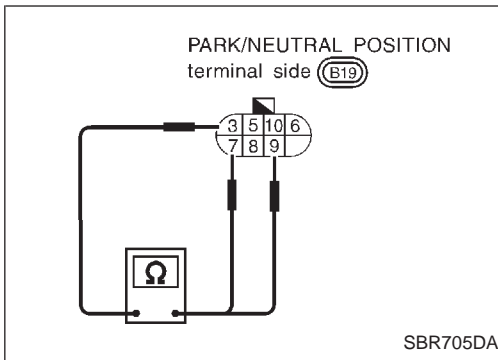

Condition	Continuity between terminals ③ and ⑦	Continuity between terminals ③ and ⑨
Shift to "P" position	Yes	No
Shift to "N" position	No	Yes
Shift to positions other than "P" and "N"	No	No

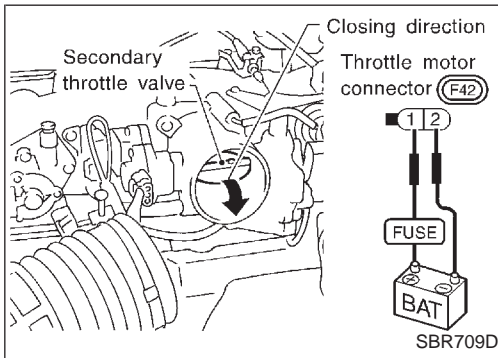

THROTTLE MOTOR

1. Remove intake manifold upper collector.
2. Disconnect connector. Manually push throttle valve to ensure that it moves properly from fully closed to fully open position.
3. With throttle valve set at fully open position, apply 12 volts (DC) across throttle motor terminals ① and ②. Throttle valve must move in fully closed direction.

GI

MA

EM

LC

EC

FE

AT

PD

FA

RA

BR

ST

RS

BT

HA

EL

IDX



General Specifications

Front brake	
Brake model	AD31VB disc brake
Cylinder bore diameter x number of pistons mm (in)	44.4 (1.748) x 2
Pad length x width x thickness mm (in)	132 x 52.5 x 11.0 (5.20 x 2.067 x 0.433)
Rotor outer diameter x thickness mm (in)	296 x 28 (11.65 x 1.10)
Rear brake	
Brake model	AD11VB disc brake
Cylinder bore diameter x number of piston mm (in)	38.2 (1.504) x 1
Pad length x width x thickness mm (in)	97.4 x 33.9 x 10 (3.835 x 1.335 x 0.39)
Rotor outer diameter x thickness mm (in)	292 x 16 (11.50 x 0.63)

Parking brake	
Brake model	DS17HE drum brake
Lining length x width x thickness mm (in)	172.0 x 25.0 x 3.2 (6.77 x 0.984 x 0.126)
Drum inner diameter mm (in)	172.0 (6.77)
Master cylinder	
Cylinder bore diameter mm (in)	25.40 (1)
Control valve	
Valve model	Proportioning valve (within master cylinder)
Split point [kPa (kg/cm ² , psi)] x reducing ratio	1,961 (20, 284) x 0.4
Brake booster	
Booster model	M215T
Diaphragm diameter mm (in)	Primary: 230 (9.06) Secondary: 205 (8.07)
Brake fluid	
Recommended brake fluid	DOT 3

Inspection and Adjustment

DISC BRAKE

Unit: mm (in)

Location	Front	Rear
Brake model	AD31VB	AD11VB
Pad wear limit		
Minimum thickness	2.0 (0.079)	
Rotor repair limit		
Maximum runout	0.07 (0.0028)	0.07 (0.0028)
Minimum thickness	26.0 (1.024)	14.0 (0.551)

BRAKE PEDAL

Unit: mm (in)

Free height "H"★	183 - 193 (7.20 - 7.60)
Depressed height "D" [under force of 490 N (50 kg, 110 lb) with engine running]	95 (3.74) or more
Clearance "C" between pedal stopper and threaded end of stop lamp switch or ASCD cancel switch	0.3 - 1.0 (0.012 - 0.039)
Pedal free play	1.0 - 3.0 (0.039 - 0.118)

★: Measured from metal panel to surface of pedal pad.

PARKING DRUM BRAKE

Unit: mm (in)

Location	Rear
Brake model	DS17HE
Lining wear limit	
Minimum thickness	1.5 (0.059)
Drum repair limit	
Maximum inner diameter	173.0 (6.81)
Brake shoe "backoff" adjustment	5 - 6 latches

PARKING BRAKE

Unit: mm (in)

Control type	Foot lever
Pedal stroke [under force of 196 N (20 kg, 44 lb)]	88 - 103 (3.46 - 4.06)
Pedal stroke when warning switch comes on	29 (1.14) or less