

**SECTION GW**

**GLASSES, WINDOW SYSTEM & MIRRORS**

**CONTENTS**

<b>PRECAUTIONS</b> .....	<b>3</b>	DELATED POWER OPERATION .....	17
Precautions for Supplemental Restraint System (SRS) "AIR BAG" and "SEAT BELT PRE-TENSIONER" .....	3	ANTI-PINCH SYSTEM .....	17
Handling for Adhesive and Primer .....	3	POWER WINDOW CONTROL BY THE KEY CYLINDER SWITCH .....	17
Wiring Diagrams and Trouble Diagnosis .....	3	Schematic .....	18
<b>PREPARATION</b> .....	<b>4</b>	Wiring Diagram —WINDOW— .....	19
Special Service Tools .....	4	Terminals and Reference Value for Driver Door Control Unit .....	25
Commercial Service Tools .....	4	Terminals and Reference Value for Passenger, Rear LH, RH Door Control Unit .....	25
<b>SQUEAK AND RATTLE TROUBLE DIAGNOSES</b> .....	<b>5</b>	Trouble Diagnosis Symptom Chart .....	26
Work Flow .....	5	Communication Signal Circuit Check .....	28
CUSTOMER INTERVIEW .....	5	Front Power Window Motor (Driver Side) Circuit Check .....	30
DUPLICATE THE NOISE AND TEST DRIVE .....	6	Front Power Window Motor (Passenger Side) Circuit Check .....	31
CHECK RELATED SERVICE BULLETINS .....	6	Rear Power Window Motor (LH or RH) Circuit Check .....	32
LOCATE THE NOISE AND IDENTIFY THE ROOT CAUSE .....	6	Limit Switch Check (Driver Side) .....	33
REPAIR THE CAUSE .....	6	Limit Switch Check (Passenger Side) .....	34
CONFIRM THE REPAIR .....	7	Limit Switch Circuit Check (Rear LH or RH) .....	35
Generic Squeak and Rattle Troubleshooting .....	7	Encoder Circuit Check (Driver Side) .....	37
INSTRUMENT PANEL .....	7	Encoder Circuit Check (Passenger Side) .....	38
CENTER CONSOLE .....	7	Encoder Circuit Check (Rear LH or RH) .....	40
DOORS .....	7	Driver Door Control Unit Circuit Check .....	42
TRUNK .....	8	Passenger Door Control Unit Circuit Check .....	42
SUNROOF/HEADLINING .....	8	Rear Door Control Unit Circuit Check .....	43
SEATS .....	8	Door Switch Check .....	44
UNDERHOOD .....	8	Rear Power Window Switch Illumination .....	46
Diagnostic Worksheet .....	9	SCHEMATIC — SW/ILL — .....	46
<b>WINDSHIELD GLASS</b> .....	<b>11</b>	WIRING DIAGRAM — SW/ILL — .....	47
Removal and Installation .....	11	<b>FRONT DOOR GLASS AND REGULATOR</b> .....	<b>52</b>
REMOVAL .....	11	Removal and Installation .....	52
INSTALLATION .....	12	REMOVAL .....	52
<b>REAR WINDOW GLASS AND MOLDING</b> .....	<b>14</b>	INSTALLATION .....	53
Removal and Installation .....	14	INSPECTION AFTER REMOVAL .....	53
REMOVAL .....	14	DISASSEMBLY .....	53
INSTALLATION .....	14	ASSEMBLY .....	53
<b>POWER WINDOW SYSTEM</b> .....	<b>16</b>	SETTING AFTER INSTALLATION .....	54
Component Parts and Harness Connector Location .....	16	FITTING INSPECTION .....	54
System Description .....	17		
OUTLINE .....	17		
OPERATIVE CONDITION .....	17		

<b>REAR DOOR GLASS AND REGULATOR</b> .....	<b>55</b>	Schematic .....	83
Removal and Installation .....	55	Wiring Diagram —MIRROR— .....	84
REMOVAL .....	55	Terminals and Reference Values for Driver Side	
INSTALLATION .....	57	Door Mirror Control Unit and Passenger Side Door	
INSPECTION AFTER REMOVAL .....	57	Mirror Control Unit .....	87
SETTING AFTER INSTALLATION .....	57	Terminals and Reference Values for BCM .....	88
FITTING INSPECTION .....	57	Work Flow .....	89
<b>INSIDE MIRROR</b> .....	<b>58</b>	Preliminary Check .....	89
Wiring Diagram—I/MIRR— .....	58	POWER SUPPLY AND GROUND CIRCUIT	
Removal and Installation .....	59	INSPECTION .....	89
AUTO ANTI-DAZZLING INSIDE MIRROR .....	59	CONSULT-II Function .....	91
<b>REAR WINDOW DEFOGGER</b> .....	<b>60</b>	CONSULT-II BASIC OPERATION PROCEDURE	
Component Parts and Harness Connector Location..	60	... 91	
System Description .....	60	IVMS COMMUNICATION INSPECTION .....	92
Schematic .....	62	COMMUNICATION SYSTEM A .....	94
Wiring Diagram—DEF— .....	63	COMMUNICATION SYSTEM B .....	95
Terminals and reference value for BCM .....	66	COMMUNICATION SYSTEM C .....	95
Work Flow .....	66	SELF-DIAGNOSIS RESULTS .....	95
Preliminary Check .....	66	DATA MONITOR .....	96
POWER SUPPLY AND GROUND CIRCUIT		ACTIVE TEST .....	98
INSPECTION .....	66	On Board Diagnosis .....	99
CONSULT-II Function .....	67	DIAGNOSIS ITEM .....	99
CONSULT-II BASIC OPERATION PROCEDURE		COMMUNICATION DIAGNOSIS .....	99
... 67		COMMUNICATION SYSTEM A .....	101
DATA MONITOR .....	68	COMMUNICATION SYSTEM B .....	101
ACTIVE TEST .....	68	COMMUNICATION SYSTEM C .....	102
Trouble Diagnoses Symptom Chart .....	69	SWITCH MONITOR .....	102
Rear Window Defogger Switch Circuit Check. ....	69	ON BOARD DIAGNOSIS FOR AUTOMATIC	
Rear Window Defogger and Door Mirror Defogger		DRIVE POSITIONER .....	104
Circuit Check .....	70	Symptom Chart .....	106
Rear Window Defogger Circuit Check .....	73	Door Mirror Remote Control Switch (Changeover	
Door Mirror Defogger Power Supply Circuit Check..	74	Switch) Circuit Inspection .....	106
Driver Side Door Mirror Defogger Circuit Check ....	76	Back-up Input Signal Circuit Inspection In R Position	
Passenger Side Door Mirror Defogger Circuit Check		... 108	
... 77		Door Mirror Remote Control Switch (Mirror Switch)	
Filament Check .....	77	Circuit Inspection .....	109
Filament Repair .....	78	Mirror Motors Circuit Inspection .....	110
REPAIR EQUIPMENT .....	78	Mirror Sensors Circuit Inspection .....	112
REPAIRING PROCEDURE .....	78	<b>DOOR MIRROR</b> .....	<b>115</b>
<b>REVERSE INTERLOCK DOOR MIRROR SYSTEM..</b>	<b>80</b>	Removal and Installation .....	115
System Description .....	80	REMOVAL .....	115
OUTLINE OF OPERATION .....	80	INSTALLATION .....	115
MIRROR POSITION MEMORY FUNCTIONS ....	81	Disassembly and Assembly .....	116
POWER SUPPLY AND GROUND .....	81	DISASSEMBLY .....	116
Component Parts and Harness Connector Location..	82	ASSEMBLY .....	117

# PRECAUTIONS

## PRECAUTIONS

PF0:00001

### Precautions for Supplemental Restraint System (SRS) “AIR BAG” and “SEAT BELT PRE-TENSIONER”

EIS00416

The Supplemental Restraint System such as “AIR BAG” and “SEAT BELT PRE-TENSIONER”, used along with a front seat belt, helps to reduce the risk or severity of injury to the driver and front passenger for certain types of collision. This system includes seat belt switch inputs and dual stage front air bag modules. The SRS system uses the seat belt switches to determine the front air bag deployment, and may only deploy one front air bag, depending on the severity of a collision and whether the front occupants are belted or unbelted. Information necessary to service the system safely is included in the SRS and SB section of this Service Manual.

#### **WARNING:**

- To avoid rendering the SRS inoperative, which could increase the risk of personal injury or death in the event of a collision which would result in air bag inflation, all maintenance must be performed by an authorized NISSAN/INFINITI dealer.
- Improper maintenance, including incorrect removal and installation of the SRS, can lead to personal injury caused by unintentional activation of the system. For removal of Spiral Cable and Air Bag Module, see the SRS section.
- Do not use electrical test equipment on any circuit related to the SRS unless instructed to in this Service Manual. SRS wiring harnesses can be identified by yellow and/or orange harnesses or harness connectors.

### Handling for Adhesive and Primer

EIS0001Z

- Do not use an adhesive which is past its usable term. Shelf life of this product is limited to six months after the date of manufacture. Carefully adhere to the expiration or manufacture date printed on the box.
- Keep primers and adhesive in a cool, dry place. Ideally, then should be stored in a refrigerator.
- Open the seal of the primer and adhesive just before application. Do not use the remainder.
- Before application, be sure to shake the primer container to stir the content. If any floating materials are found, do not use it.
- If any primer or adhesive contacts the skin, wipe it off with white gasoline or equivalent and wash the skin with soap.
- When using primer and adhesive, always observe the precautions in the instruction manual.

### Wiring Diagrams and Trouble Diagnosis

EIS000J0

- If each local control unit (LCU) connector is left disconnected for at least 1 minute, the BCM stores a communication inactive. After reconnecting the connector, any of the following steps shall be done. “Disconnect the BCM battery power supply”, Execute Erase memory with CONSULT-II.

When you read wiring diagrams, refer to the followings:

- [GI-14, "How to Read Wiring Diagrams"](#) in GI section
- [PG-2, "POWER SUPPLY ROUTING"](#) in PG section

When you perform trouble diagnosis, refer to the followings:

- [GI-10, "HOW TO FOLLOW TEST GROUPS IN TROUBLE DIAGNOSES"](#) in GI section
- [GI-26, "How to Perform Efficient Diagnosis for an Electrical Incident"](#) in GI section

Check for any service bulletins before servicing the vehicle.

# PREPARATION

## PREPARATION

PFP:00002

### Special Service Tools

EIS009LQ

The actual shapes of Kent-Moore tools may differ from those of special service tools illustrated here.

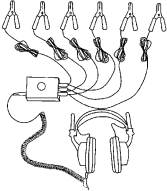
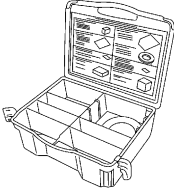
Tool number (Kent-Moore No.) Tool name	Description
(J-39570) Chassis ear   SIIA0993E	Locating the noise
(J-43980) NISSAN Squeak and Rattle Kit   SIIA0994E	Repairing the cause of noise

### Commercial Service Tools

EIS009LR

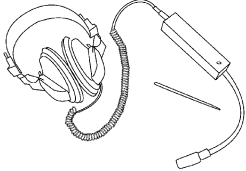
Tool name	Description
Engine ear   SIIA0995E	Locating the noise

# SQUEAK AND RATTLE TROUBLE DIAGNOSES

## SQUEAK AND RATTLE TROUBLE DIAGNOSES

PFP:00000

### Work Flow

E/S009LS

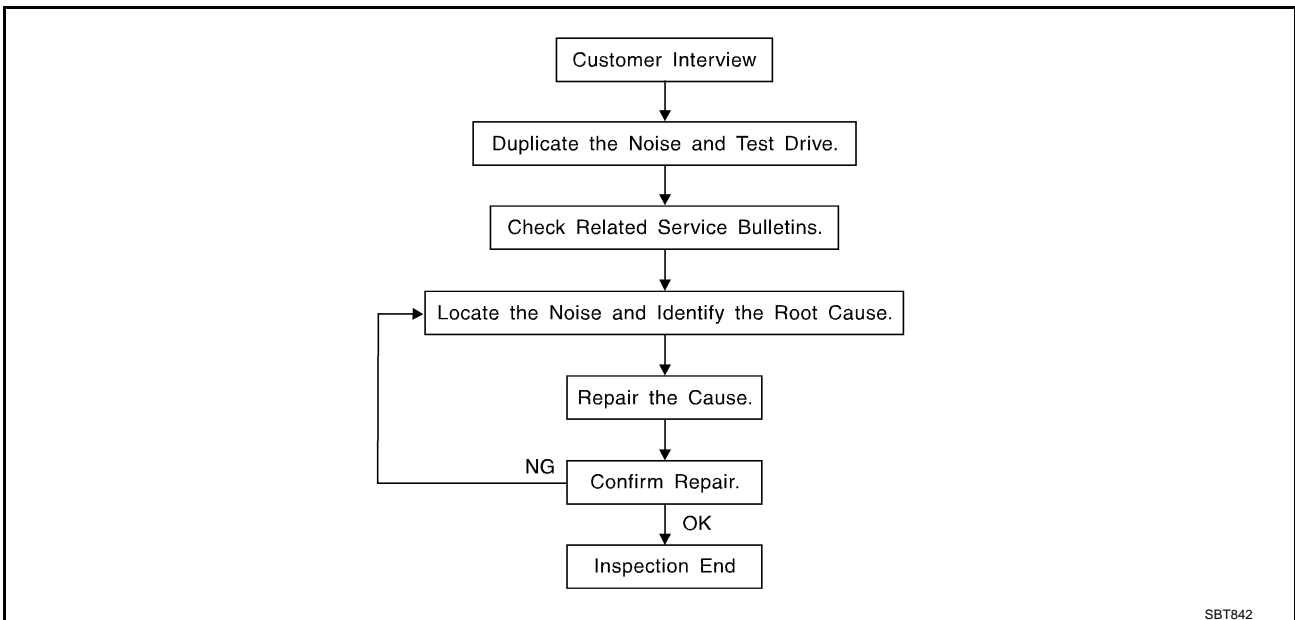

### CUSTOMER INTERVIEW

Interview the customer if possible, to determine the conditions that exist when the noise occurs. Use the Diagnostic Worksheet during the interview to document the facts and conditions when the noise occurs and any customer's comments; refer to [GW-9, "Diagnostic Worksheet"](#). This information is necessary to duplicate the conditions that exist when the noise occurs.

- The customer may not be able to provide a detailed description or the location of the noise. Attempt to obtain all the facts and conditions that exist when the noise occurs (or does not occur).
- If there is more than one noise in the vehicle, be sure to diagnose and repair the noise that the customer is concerned about. This can be accomplished by test driving the vehicle with the customer.
- After identifying the type of noise, isolate the noise in terms of its characteristics. The noise characteristics are provided so the customer, service adviser and technician are all speaking the same language when defining the noise.
- Squeak—(Like tennis shoes on a clean floor)  
Squeak characteristics include the light contact/fast movement/brought on by road conditions/hard surfaces=higher pitch noise/softer surfaces=lower pitch noises/edge to surface=chirping
- Creak—(Like walking on an old wooden floor)  
Creak characteristics include firm contact/slow movement/twisting with a rotational movement/pitch dependent on materials/often brought on by activity.
- Rattle—(Like shaking a baby rattle)  
Rattle characteristics include the fast repeated contact/vibration or similar movement/loose parts/missing clip or fastener/incorrect clearance.
- Knock—(Like a knock on a door)  
Knock characteristics include hollow sounding/sometimes repeating/often brought on by driver action.
- Tick—(Like a clock second hand)  
Tick characteristics include gentle contacting of light materials/loose components/can be caused by driver action or road conditions.
- Thump—(Heavy, muffled knock noise)  
Thump characteristics include softer knock/dead sound often brought on by activity.
- Buzz—(Like a bumble bee)  
Buzz characteristics include high frequency rattle/firm contact.
- Often the degree of acceptable noise level will vary depending upon the person. A noise that you may judge as acceptable may be very irritating to the customer.
- Weather conditions, especially humidity and temperature, may have a great effect on noise level.

# SQUEAK AND RATTLE TROUBLE DIAGNOSES

## DUPLICATE THE NOISE AND TEST DRIVE

If possible, drive the vehicle with the customer until the noise is duplicated. Note any additional information on the Diagnostic Worksheet regarding the conditions or location of the noise. This information can be used to duplicate the same conditions when you confirm the repair.

If the noise can be duplicated easily during the test drive, to help identify the source of the noise, try to duplicate the noise with the vehicle stopped by doing one or all of the following:

- 1) Close a door.
  - 2) Tap or push/pull around the area where the noise appears to be coming from.
  - 3) Rev the engine.
  - 4) Use a floor jack to recreate vehicle "twist".
  - 5) At idle, apply engine load (electrical load, half-clutch on M/T models, drive position on A/T models).
  - 6) Raise the vehicle on a hoist and hit a tire with a rubber hammer.
- Drive the vehicle and attempt to duplicate the conditions the customer states exist when the noise occurs.
  - If it is difficult to duplicate the noise, drive the vehicle slowly on an undulating or rough road to stress the vehicle body.

## CHECK RELATED SERVICE BULLETINS

After verifying the customer concern or symptom, check ASIST for Technical Service Bulletins (TSBs) related to that concern or symptom.

If a TSB relates to the symptom, follow the procedure to repair the noise.

## LOCATE THE NOISE AND IDENTIFY THE ROOT CAUSE

1. Narrow down the noise to a general area. To help pinpoint the source of the noise, use a listening tool (Chassis Ear: J-39570, Engine Ear and mechanics stethoscope).
2. Narrow down the noise to a more specific area and identify the cause of the noise by:
  - removing the components in the area that you suspect the noise is coming from.  
Do not use too much force when removing clips and fasteners, otherwise clips and fastener can be broken or lost during the repair, resulting in the creation of new noise.
  - tapping or pushing/pulling the component that you suspect is causing the noise.  
Do not tap or push/pull the component with excessive force, otherwise the noise will be eliminated only temporarily.
  - feeling for a vibration with your hand by touching the component(s) that you suspect is (are) causing the noise.
  - placing a piece of paper between components that you suspect are causing the noise.
  - looking for loose components and contact marks.  
Refer to [GW-7, "Generic Squeak and Rattle Troubleshooting"](#).

## REPAIR THE CAUSE

- If the cause is a loose component, tighten the component securely.
- If the cause is insufficient clearance between components:
  - separate components by repositioning or loosening and retightening the component, if possible.
  - insulate components with a suitable insulator such as urethane pads, foam blocks, felt cloth tape or urethane tape. A Nissan Squeak and Rattle Kit (J-43980) is available through your authorized Nissan Parts Department.

### CAUTION:

**Do not use excessive force as many components are constructed of plastic and may be damaged.**

**Always check with the Parts Department for the latest parts information.**

**The following materials are contained in the Nissan Squeak and Rattle Kit (J-43980). Each item can be ordered separately as needed.**

**URETHANE PADS [1.5 mm (0.059 in) thick]**

**Insulates connectors, harness, etc.**

**76268-9E005: 100 × 135 mm (3.94 × 5.31 in)/76884-71L01: 60 × 85 mm (2.36 × 3.35 in)/76884-**

**71L02: 15 × 25 mm (0.59 × 0.98 in)**

**INSULATOR (Foam blocks)**

**Insulates components from contact. Can be used to fill space behind a panel.**

**73982-9E000: 45 mm (1.77 in) thick, 50 × 50 mm (1.97 × 1.97 in)/73982-**

**50Y00: 10 mm (0.39 in) thick, 50 × 50 mm (1.97 × 1.97 in)**

# SQUEAK AND RATTLE TROUBLE DIAGNOSES

## INSULATOR (Light foam block)

80845-71L00: 30 mm (1.18 in) thick, 30 × 50 mm (1.18 × 1.97 in)

## FELT CLOTHTAPE

Used to insulate where movement does not occur. Ideal for instrument panel applications.

68370-4B000: 15 × 25 mm (0.59 × 0.98 in) pad/68239-13E00: 5 mm (0.20 in) wide tape roll

The following materials, not found in the kit, can also be used to repair squeaks and rattles.

## UHMW (TEFLON) TAPE

Insulates where slight movement is present. Ideal for instrument panel applications.

## SILICONE GREASE

Used in place of UHMW tape that will be visible or not fit.

Note: Will only last a few months.

## SILICONE SPRAY

Use when grease cannot be applied.

## DUCT TAPE

Use to eliminate movement.

## CONFIRM THE REPAIR

Confirm that the cause of a noise is repaired by test driving the vehicle. Operate the vehicle under the same conditions as when the noise originally occurred. Refer to the notes on the Diagnostic Worksheet.

## Generic Squeak and Rattle Troubleshooting

E/IS009LT

Refer to Table of Contents for specific component removal and installation information.

## INSTRUMENT PANEL

Most incidents are caused by contact and movement between:

1. The cluster lid A and instrument panel
2. Acrylic lens and combination meter housing
3. Instrument panel to front pillar garnish
4. Instrument panel to windshield
5. Instrument panel mounting pins
6. Wiring harnesses behind the combination meter
7. A/C defroster duct and duct joint

These incidents can usually be located by tapping or moving the components to duplicate the noise or by pressing on the components while driving to stop the noise. Most of these incidents can be repaired by applying felt cloth tape or silicon spray (in hard to reach areas). Urethane pads can be used to insulate wiring harness.

### CAUTION:

**Do not use silicone spray to isolate a squeak or rattle. If you saturate the area with silicone, you will not be able to recheck the repair.**

## CENTER CONSOLE

Components to pay attention to include:

1. Shifter assembly cover to finisher
2. A/C control unit and cluster lid C
3. Wiring harnesses behind audio and A/C control unit

The instrument panel repair and isolation procedures also apply to the center console.

## DOORS

Pay attention to the:

1. Finisher and inner panel making a slapping noise
2. Inside handle escutcheon to door finisher
3. Wiring harnesses tapping
4. Door striker out of alignment causing a popping noise on starts and stops

Tapping or moving the components or pressing on them while driving to duplicate the conditions can isolate many of these incidents. You can usually insulate the areas with felt cloth tape or insulator foam blocks from the Nissan Squeak and Rattle Kit (J-43980) to repair the noise.

A

B

C

D

E

F

G

H

GW

J

K

L

M

# SQUEAK AND RATTLE TROUBLE DIAGNOSES

---

## TRUNK

Trunk noises are often caused by a loose jack or loose items put into the trunk by the owner. In addition look for:

1. Trunk lid dumpers out of adjustment
2. Trunk lid striker out of adjustment
3. The trunk lid torsion bars knocking together
4. A loose license plate or bracket

Most of these incidents can be repaired by adjusting, securing or insulating the item(s) or component(s) causing the noise.

## SUNROOF/HEADLINING

Noises in the sunroof/headlining area can often be traced to one of the following:

1. Sunroof lid, rail, linkage or seals making a rattle or light knocking noise
2. Sunvisor shaft shaking in the holder
3. Front or rear windshield touching headlining and squeaking

Again, pressing on the components to stop the noise while duplicating the conditions can isolate most of these incidents. Repairs usually consist of insulating with felt cloth tape.

## SEATS

When isolating seat noise it's important to note the position the seat is in and the load placed on the seat when the noise is present. These conditions should be duplicated when verifying and isolating the cause of the noise.

Cause of seat noise include:

1. Headrest rods and holder
2. A squeak between the seat pad cushion and frame
3. The rear seatback lock and bracket

These noises can be isolated by moving or pressing on the suspected components while duplicating the conditions under which the noise occurs. Most of these incidents can be repaired by repositioning the component or applying urethane tape to the contact area.

## UNDERHOOD

Some interior noise may be caused by components under the hood or on the engine wall. The noise is then transmitted into the passenger compartment.

Causes of transmitted underhood noise include:

1. Any component mounted to the engine wall
2. Components that pass through the engine wall
3. Engine wall mounts and connectors
4. Loose radiator mounting pins
5. Hood bumpers out of adjustment
6. Hood striker out of adjustment

These noises can be difficult to isolate since they cannot be reached from the interior of the vehicle. The best method is to secure, move or insulate one component at a time and test drive the vehicle. Also, engine RPM or load can be changed to isolate the noise. Repairs can usually be made by moving, adjusting, securing, or insulating the component causing the noise.



# SQUEAK AND RATTLE TROUBLE DIAGNOSES

## Diagnostic Worksheet

EIS009LU



### SQUEAK & RATTLE DIAGNOSTIC WORKSHEET

Dear Infiniti Customer:

We are concerned about your satisfaction with your Infiniti vehicle. Repairing a squeak or rattle sometimes can be very difficult. To help us fix your Infiniti right the first time, please take a moment to note the area of the vehicle where the squeak or rattle occurs and under what conditions. You may be asked to take a test drive with a service advisor or technician to ensure we confirm the noise you are hearing.

#### I. WHERE DOES THE NOISE COME FROM? (circle the area of the vehicle)

The illustrations are for reference only, and may not reflect the actual configuration of your vehicle.

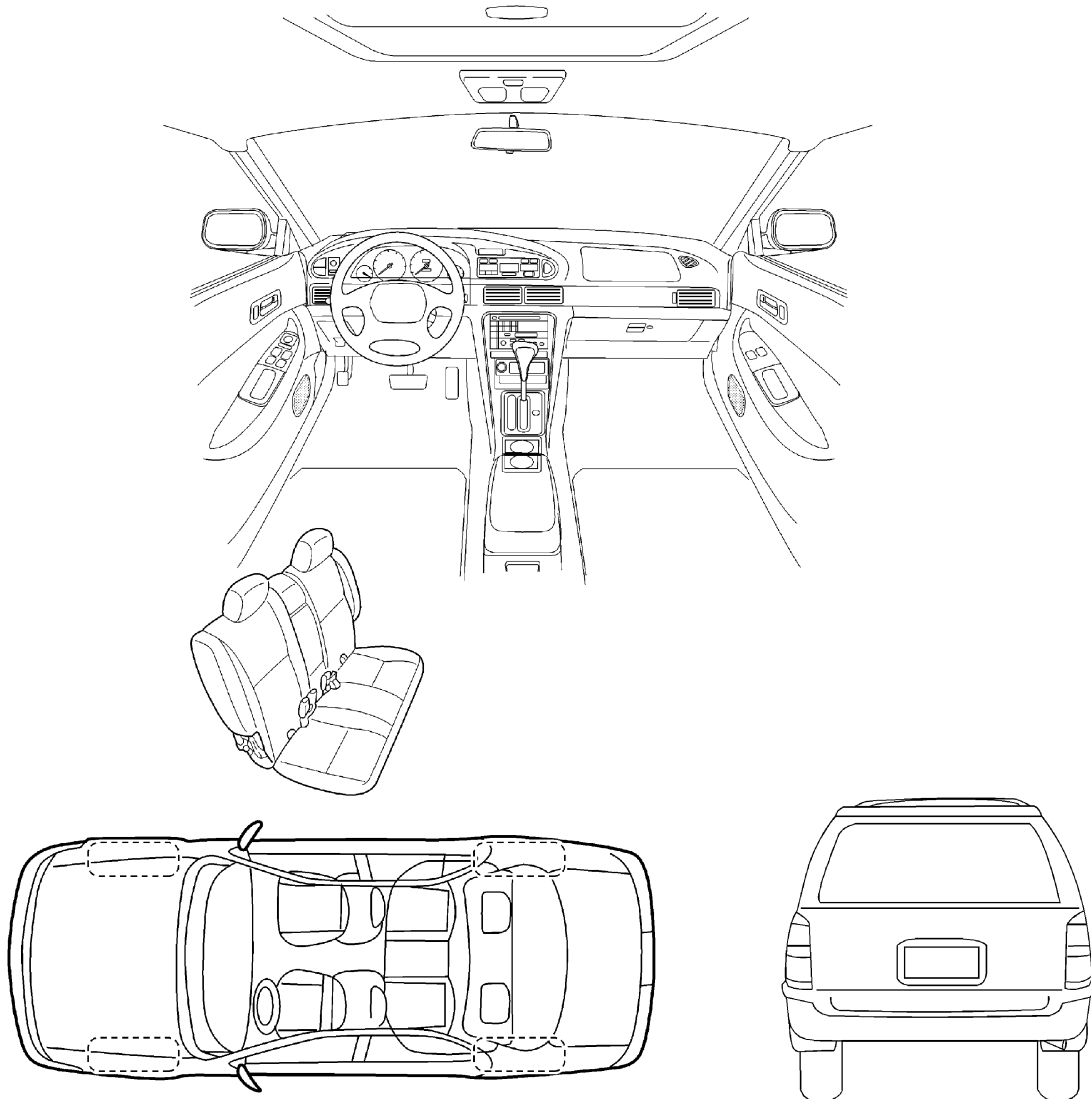

Continue to the back of the worksheet and briefly describe the location of the noise or rattle. In addition, please indicate the conditions which are present when the noise occurs.

SBT860

A  
B  
C  
D  
E  
F  
G  
H  
GW  
J  
K  
L  
M

# SQUEAK AND RATTLE TROUBLE DIAGNOSES

## SQUEAK & RATTLE DIAGNOSTIC WORKSHEET- page 2

Briefly describe the location where the noise occurs:

---

---

---

### II. WHEN DOES IT OCCUR? (check the boxes that apply)

- |  |   |
|--|---|
| <input type="checkbox"/> anytime                             | <input type="checkbox"/> after sitting out in the sun |
| <input type="checkbox"/> 1 <sup>st</sup> time in the morning | <input type="checkbox"/> when it is raining or wet    |
| <input type="checkbox"/> only when it is cold outside        | <input type="checkbox"/> dry or dusty conditions      |
| <input type="checkbox"/> only when it is hot outside         | <input type="checkbox"/> other: _____                 |

### III. WHEN DRIVING:

- through driveways
- over rough roads
- over speed bumps
- only at about \_\_\_\_ mph
- on acceleration
- coming to a stop
- on turns : left, right or either (circle)
- with passengers or cargo
- other: \_\_\_\_\_
- after driving \_\_\_\_ miles or \_\_\_\_ minutes

### IV. WHAT TYPE OF NOISE?

- squeak (like tennis shoes on a clean floor)
- creak (like walking on an old wooden floor)
- rattle (like shaking a baby rattle)
- knock (like a knock on a door)
- tick (like a clock second hand)
- thump (heavy, muffled knock noise)
- buzz (like a bumble bee)

### TO BE COMPLETED BY DEALERSHIP PERSONNEL

#### Test Drive Notes:

---

---

	YES	NO	Initials of person performing
Vehicle test driven with customer	<input type="checkbox"/>	<input type="checkbox"/>	_____
- Noise verified on test drive	<input type="checkbox"/>	<input type="checkbox"/>	_____
- Noise source located and repaired	<input type="checkbox"/>	<input type="checkbox"/>	_____
- Follow up test drive performed to confirm repair	<input type="checkbox"/>	<input type="checkbox"/>	_____

VIN: \_\_\_\_\_ Customer Name: \_\_\_\_\_

W.O. #: \_\_\_\_\_ Date: \_\_\_\_\_

**This form must be attached to Work Order**

# WINDSHIELD GLASS

PF7:72712

EIS009LV

## WINDSHIELD GLASS

### Removal and Installation

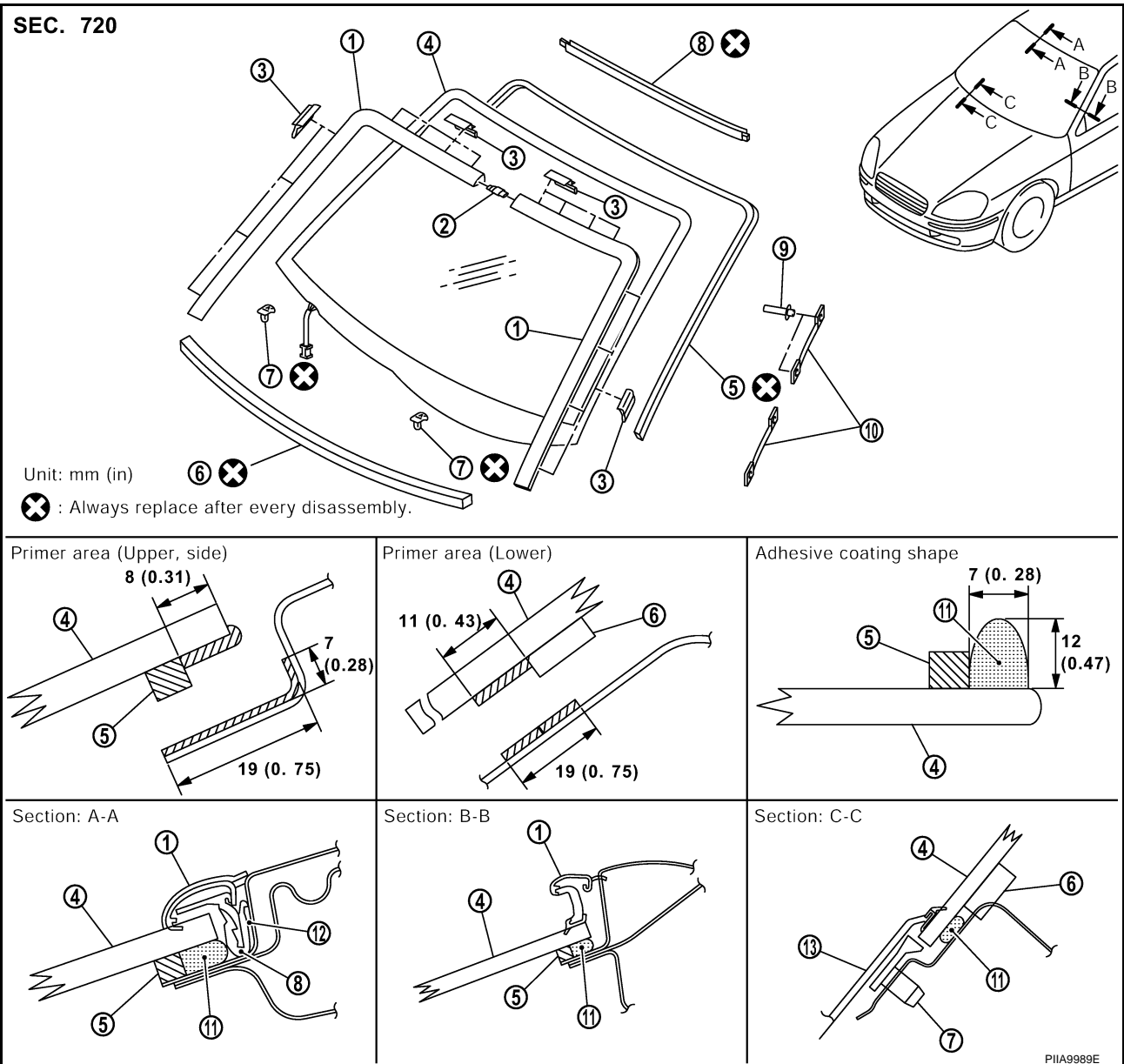

- |                       |                       |                                |
|-----------------------|-----------------------|--------------------------------|
| 1. Windshield molding | 2. Joint              | 3. Clip                        |
| 4. Windshield glass   | 5. Open cell foam dam | 6. Insulator                   |
| 7. Spacer             | 8. Fastener (upper)   | 9. Rivet                       |
| 10. Fastener (lower)  | 11. Adhesive          | 12. Double-faced adhesive tape |
| 13. Cowl top cover    |                       |                                |

### REMOVAL

1. Remove the body side welt on the front pillar. Refer to [EI-39, "BODY SIDE TRIM"](#).
2. Remove the front pillar garnish. Refer to [EI-39, "BODY SIDE TRIM"](#).
3. Remove the headlining. Refer to [EI-56, "HEADLINING"](#).
4. Remove the cowl top cover. Refer to [EI-20, "COWL TOP"](#).
5. Remove the side lower part of windshield molding from the fastener (lower) by disconnecting clips, and then pull upper part of the molding to remove.
6. Apply a protective tape around the windshield glass to protect the painted surface from damage.
7. Remove glass using piano wire or power cutting tool and an inflatable pump bag.

A  
B  
C  
D  
E  
F  
G  
H  
J  
K  
L  
M

GW

# WINDSHIELD GLASS

- If a windshield glass will be reused, mark the body and the glass with mating marks.

## WARNING:

When cutting the glass from the vehicle, always wear safety glasses and heavy gloves to help prevent glass splinters from entering your eyes or cutting your hands.

## CAUTION:

- When a windshield glass is reused, do not use a cutting knife or power cutting tool.
- Be careful not to scratch the glass when removing.
- Do not set or stand the glass on its edge. Small chips may develop into cracks.

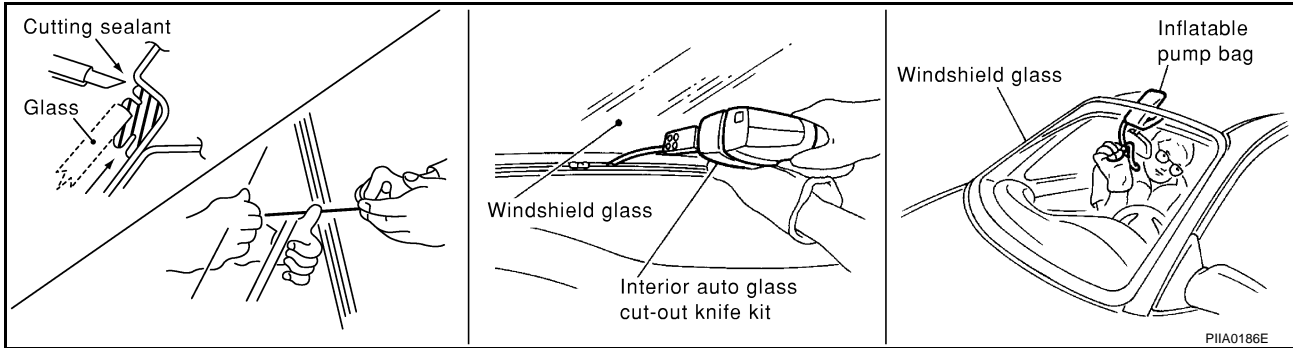

## INSTALLATION

- The open cell foam dam and the insulator should be installed in position.

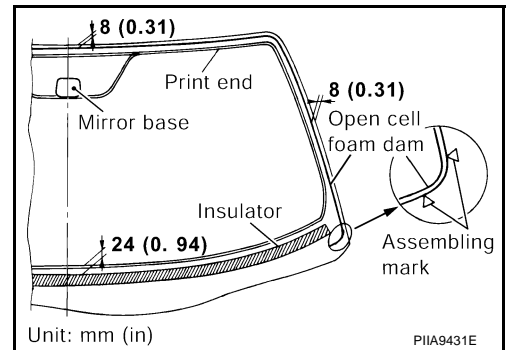

- Use a genuine Nissan Urethane Adhesive Kit or equivalent and follow the instructions furnished with it.
- While the urethane adhesive is curing, open a door window. This will prevent the glass from being forced out by passenger compartment air pressure when a door is closed.
- The fastener and the molding must be installed securely so that it is in position and leaves no gap. Install the moldings in order of lower to upper corner, connect joint, and then corner to center.
- Inform the customer that the vehicle should remain stationary until the urethane adhesive has completely cured (preferably 24 hours). Curing time varies with temperature and humidity.

## WARNING:

- Keep heat and open flames away as primers and adhesive are flammable.
- The materials contained in the kit are harmful if swallowed, and may irritate skin and eyes. Avoid contact with the skin and eyes.
- Use in an open, well ventilated location. Avoid breathing the vapors. They can be harmful if inhaled. If affected by vapor inhalation, immediately move to an area with fresh air.
- Driving the vehicle before the urethane adhesive has completely cured may affect the performance of the windshield in case of an accident.

## CAUTION:

- Do not use an adhesive which is past its usable term. Shelf life of this product is limited to six months after the date of manufacture. Carefully adhere to the expiration or manufacture date printed on the box.
- Keep primers and adhesive in a cool, dry place. Ideally, they should be stored in a refrigerator.
- Do not leave primers or adhesive cartridge unattended with their caps open or off.

# WINDSHIELD GLASS

- The vehicle should not be driven for at least 24 hours or until the urethane adhesive has completely cured. Curing time varies depending on temperature and humidity. The curing time will increase under lower temperature and lower humidity.

## Repairing Water Leaks

Leaks can be repaired without removing and reinstalling glass.

If water is leaking between the urethane adhesive material and body or glass, determine the extent of leakage. This can be done by applying water to the windshield area while pushing glass outward.

To stop the leak, apply primer (if necessary) and then urethane adhesive to the leak point.

A

B

C

D

E

F

G

H

GW

J

K

L

M

# REAR WINDOW GLASS AND MOLDING

## REAR WINDOW GLASS AND MOLDING

PFP:79712

### Removal and Installation

EIS009LW

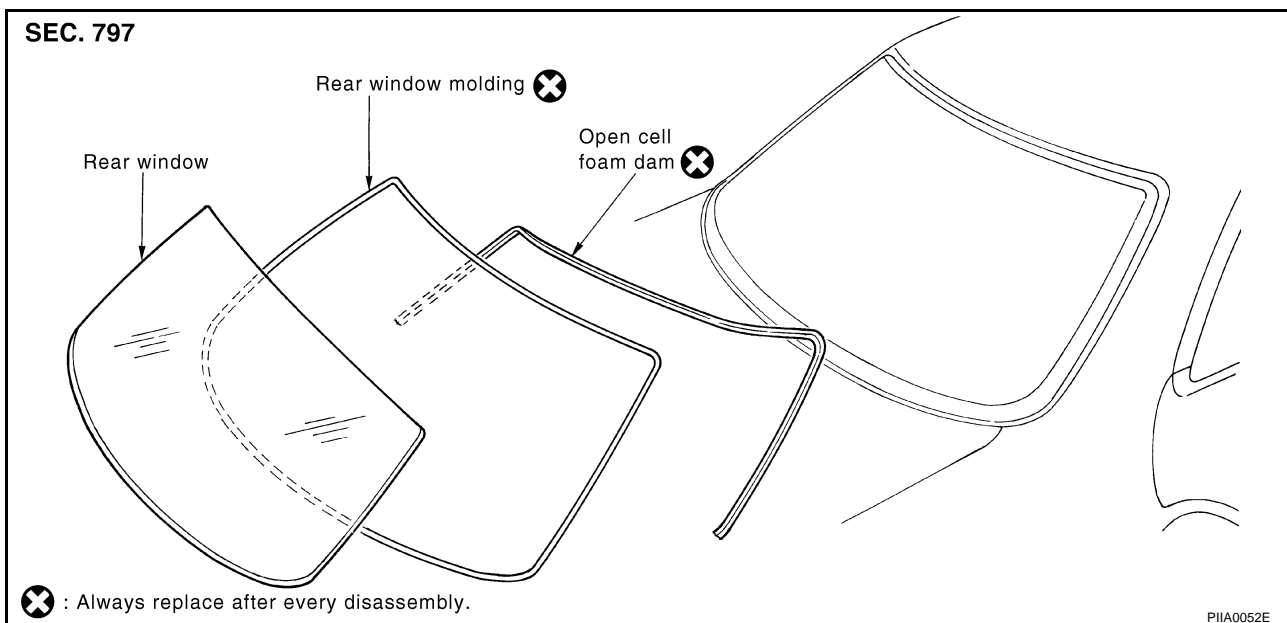

### REMOVAL

1. Remove the rear of the headlining. Refer to [EI-56, "HEADLINING"](#).
  2. Remove the rear pillar finisher. Refer to [EI-39, "BODY SIDE TRIM"](#).
  3. Remove the rear parcel shelf finisher. Refer to [EI-44, "REAR PARCEL SHELF FINISHER"](#).
  4. Remove the connectors and grounds for the rear window defogger and printed antenna.
  5. Cut the molding with the cutting knife.
  6. After removing molding using pliers, remove glass using piano wire or power cutting tool and an inflatable pump bag.
- If a rear window glass is reused, mark the body and the glass with mating marks.

#### WARNING:

When cutting the glass from the vehicle, always wear safety glasses and heavy gloves to help prevent glass splinters from entering your eyes or cutting your hands.

#### CAUTION:

- When a rear window glass is reused, do not use a cutting knife or power cutting tool.
- Be careful not to scratch the glass when removing.
- Do not set or stand the glass on its edge. Small chips may develop into cracks.

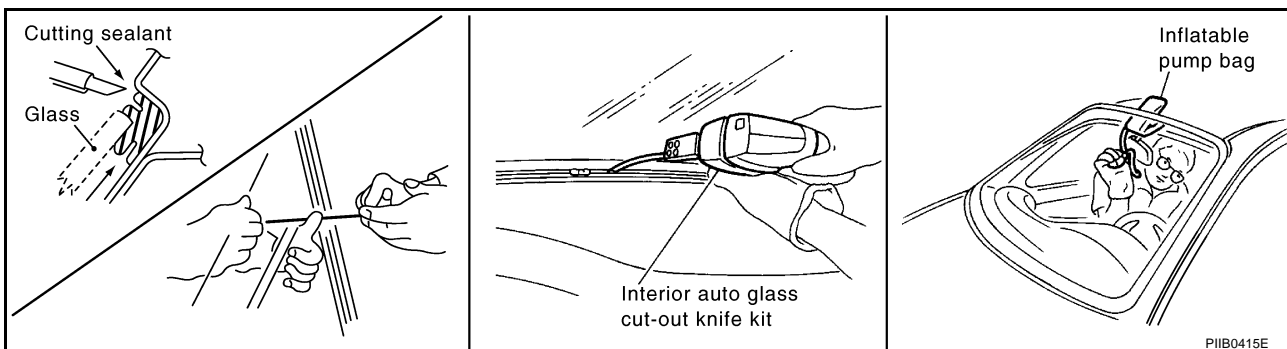

### INSTALLATION

- Use a genuine Nissan Urethane Adhesive Kit or equivalent and follow the instructions furnished with it.
- While the urethane adhesive is curing, open a door window. This will prevent the glass from being forced out by passenger compartment air pressure when a door is closed.
- The molding must be installed securely so that it is in position and leaves no gap.

# REAR WINDOW GLASS AND MOLDING

- Inform the customer that the vehicle should remain stationary until the urethane adhesive has completely cured (preferably 24 hours). Curing time varies with temperature and humidity.

## WARNING:

- Keep heat and open flames away as primers and adhesive are flammable.
- The materials contained in the kit are harmful if swallowed, and may irritate skin and eyes. Avoid contact with the skin and eyes.
- Use in an open, well ventilated location. Avoid breathing the vapors. They can be harmful if inhaled. If affected by vapor inhalation, immediately move to an area with fresh air.
- Driving the vehicle before the urethane adhesive has completely cured may affect the performance of the rear window in case of an accident.

## CAUTION:

- Do not use an adhesive which is past its usable term. Shelf life of this product is limited to six months after the date of manufacture. Carefully adhere to the expiration or manufacture date printed on the box.
- Keep primers and adhesive in a cool, dry place. Ideally, they should be stored in a refrigerator.
- Do not leave primers or adhesive cartridge unattended with their caps open or off.
- The vehicle should not be driven for at least 24 hours or until the urethane adhesive has completely cured. Curing time varies depending on temperature and humidity. The curing time will increase under lower temperature and lower humidity.

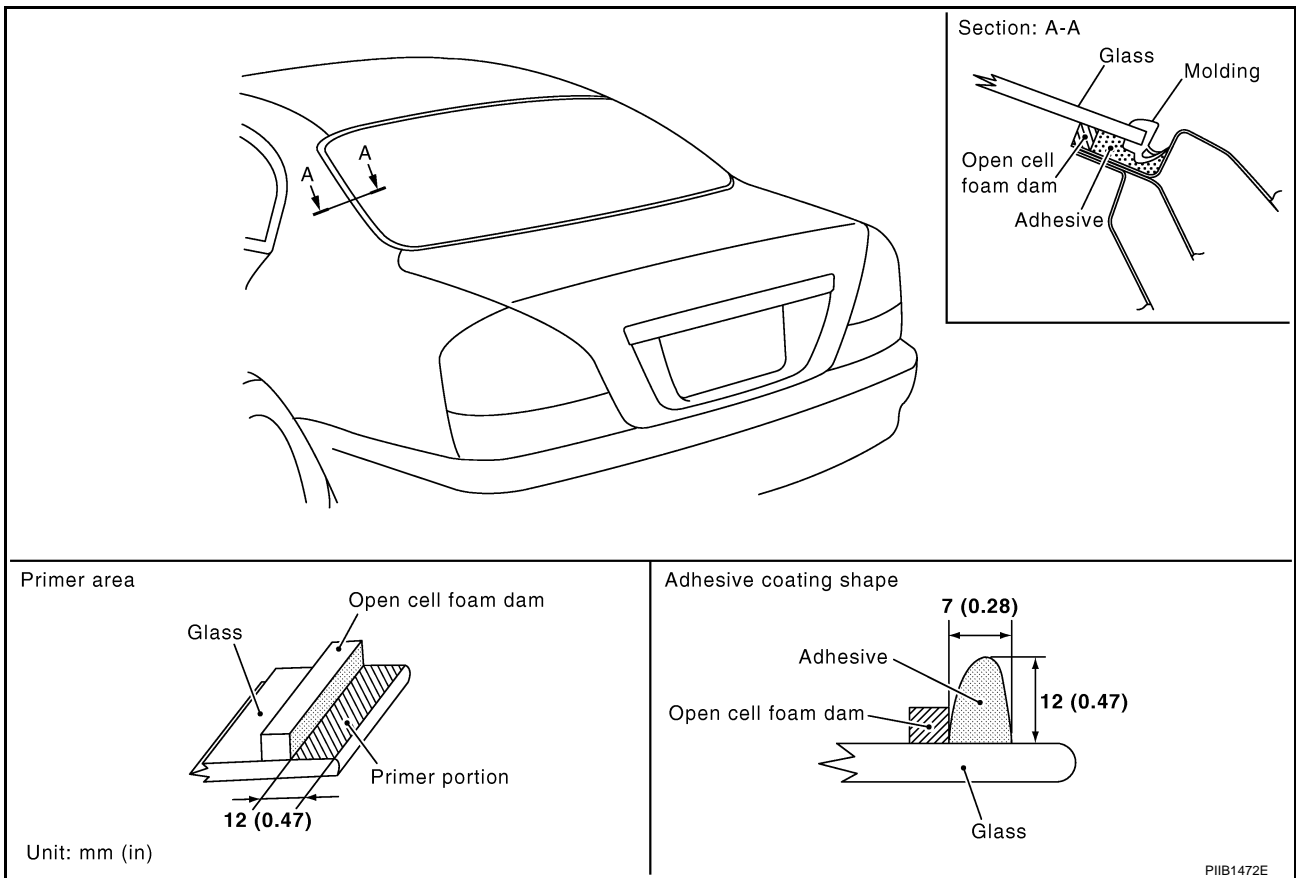

A  
B  
C  
D  
E  
F  
G  
H  
J  
K  
L  
M

GW

# POWER WINDOW SYSTEM

PFP:25401

## POWER WINDOW SYSTEM

### Component Parts and Harness Connector Location

EIS000UT

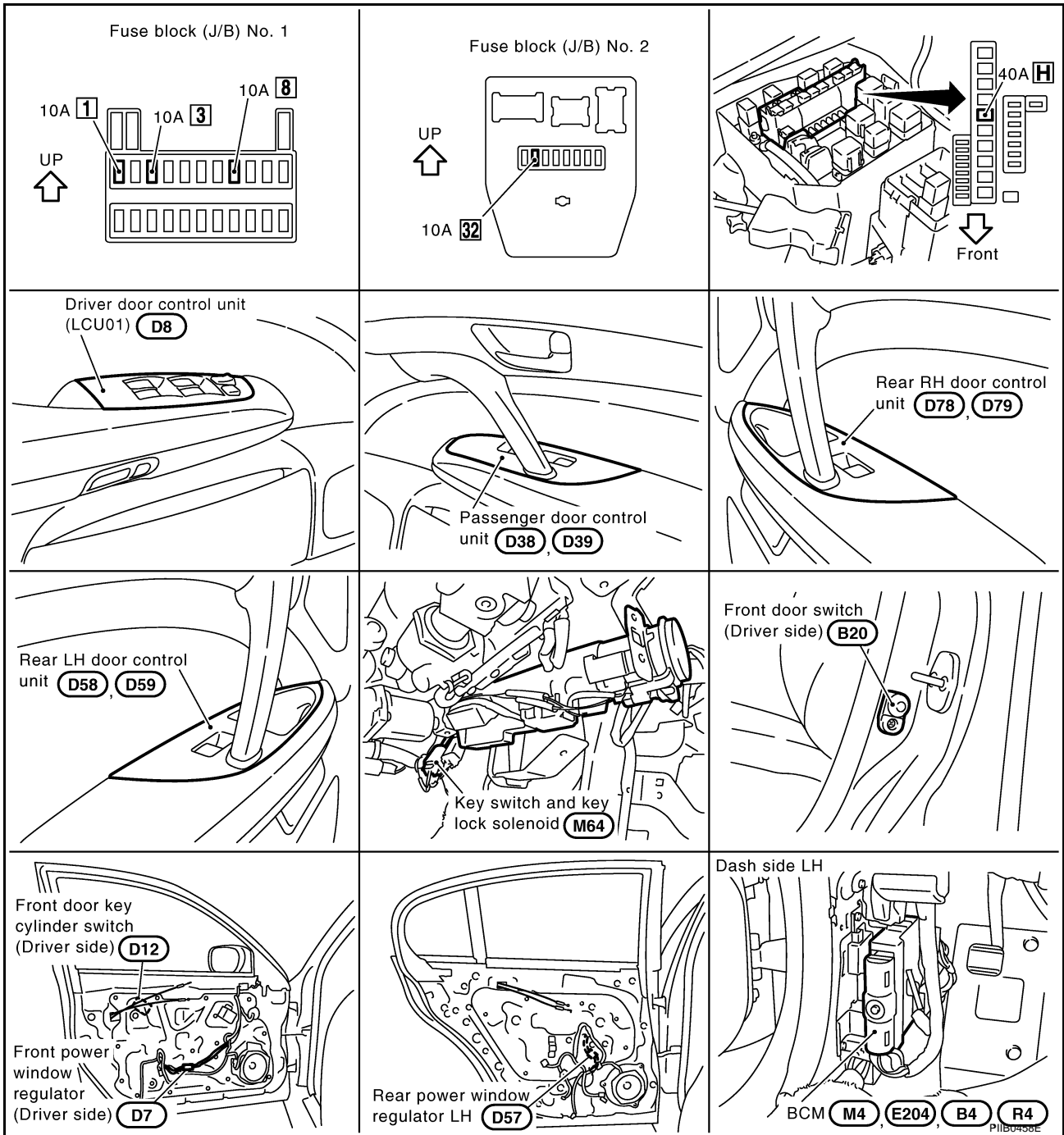



# POWER WINDOW SYSTEM

EIS000J6

## System Description

### OUTLINE

Power window system consists of

- BCM (Body Control Module)
- driver's door control unit (LCU1)
- passenger, rear LH, RH door control units
- four power window motors

BCM is connected to driver's door control unit (LCU1) via DATA LINE A-3, and driver's control unit (LCU1) and other door control units supply power and ground to each power window motor.

When ignition switch is in the "ON" position, power window will be operated depending on power window sub/main switch (which is combined with each door control unit) condition.

### OPERATIVE CONDITION

- Power windows can be raised or lowered with each sub-switch or the power window main switch located on the driver's door trim when ignition key is in the "ON" position and power window lock switch on the driver door trim is unlocked.
- When power window lock switch is locked, no windows can be raised or lowered except for driver side window.
- When ignition key is in the "ON" position, to fully open/close the front windows, press down/pull completely on the automatic switch and release it; it needs not be held. The window will automatically open/close all the way. To stop the window, pull up/press down then release the switch.

### DELAYED POWER OPERATION

When the ignition switch is turned to the "OFF" position, the power window will still operate for up to approximately 45 seconds unless the driver or passenger side door is opened. (Power window timer)

### ANTI-PINCH SYSTEM

Driver's door control unit (LCU01) /passenger, rear LH, RH door control unit monitor the power window motor operation and the power window position (full closed or other) by the signals from encoder and limit switch in power window motor.

When driver's door control unit (LCU01) /passenger, rear LH RH door control unit detect interruption during the following close operation in the each door,

driver's door control unit (LCU01) / passenger, rear LH,RH door control unit control each power window motor for open and the power window will be lowered about 150 mm (5.91 in).

- automatic close operation when ignition switch is in the "ON" position
- automatic close operation during power window timer operation

### POWER WINDOW CONTROL BY THE KEY CYLINDER SWITCH

When ignition key switch is OFF, front power window can be opened or closed by turning the front door key cylinder driver side UNLOCK / LOCK position more then 1.5 seconds over condition.

- Power window can be opened as the door key cylinder is kept fully turning to the UNLOCK position.
- Power window can be closed as the door key cylinder is kept fully turning to the LUCK position.

The power window opening stops when the following operations are carried out.

- While performing open / close the window, power window is stopped at the position as the door key cylinder is placed on NEUTRAL.
- When the ignition switch is turned ON while the power window opening is operated.

A

B

C

D

E

F

G

H

GW

J

K

L

M

# POWER WINDOW SYSTEM

## Schematic

EIS000UU

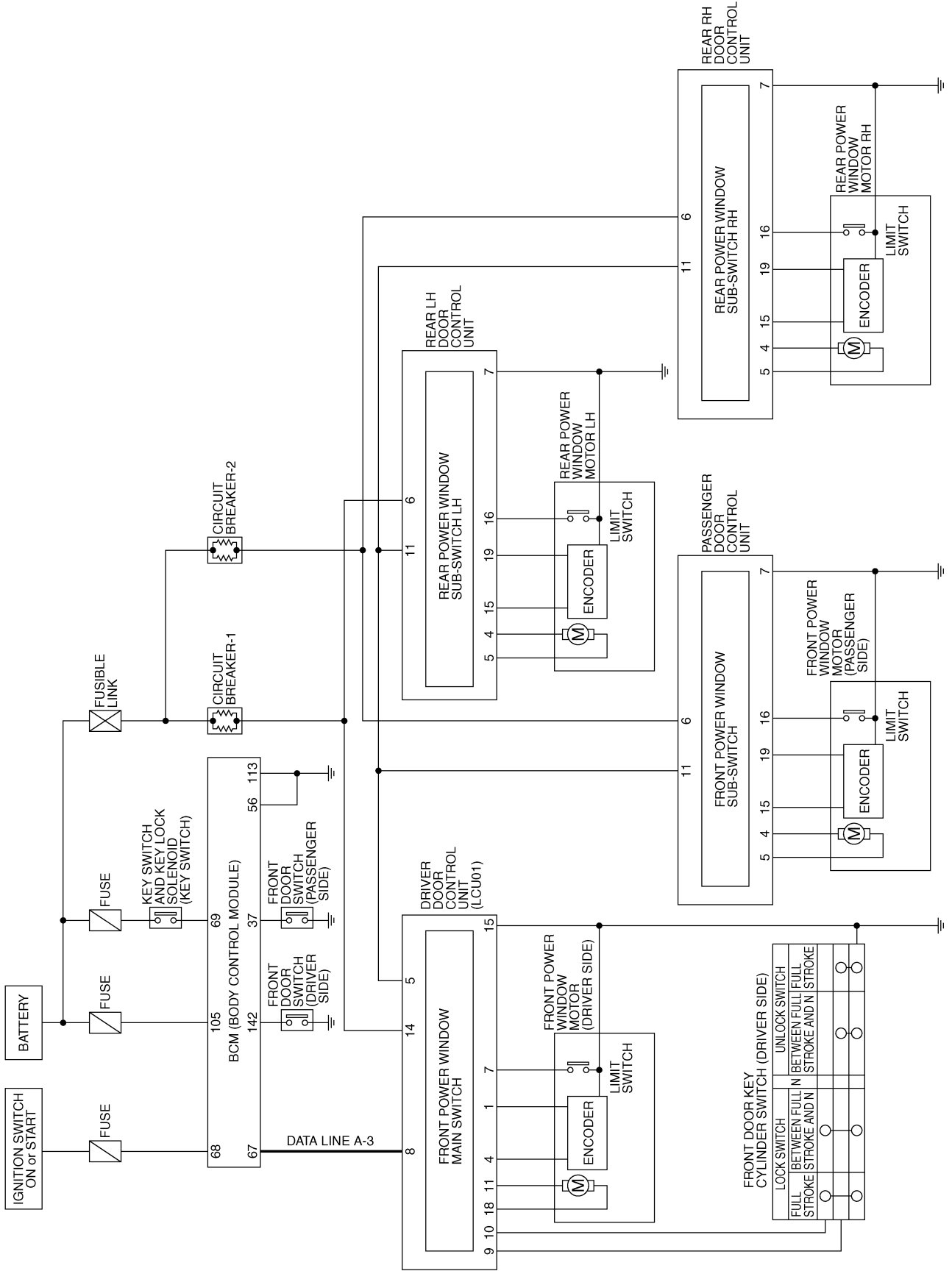

TIWM0495E

# POWER WINDOW SYSTEM

## Wiring Diagram —WINDOW—

EIS000UV

GW-WINDOW-01

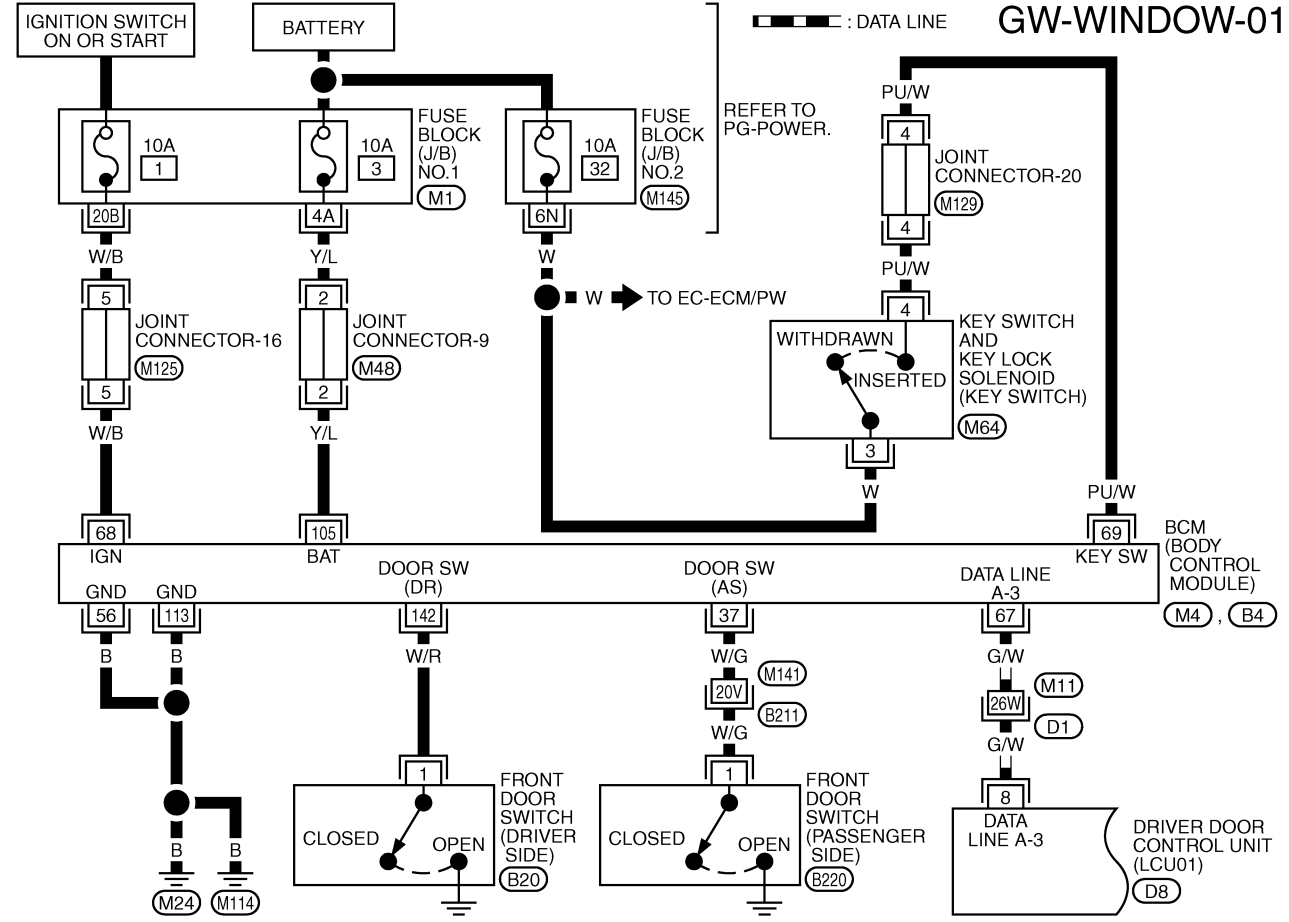

A  
B  
C  
D  
E  
F  
G  
H  
J  
K  
L  
M

GW

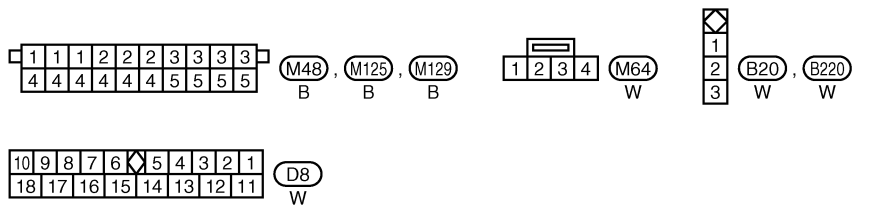

REFER TO THE FOLLOWING.

- (B211), (D1) -SUPER MULTIPLE JUNCTION (SMJ)
- (M1) -FUSE BLOCK-JUNCTION BOX (J/B) NO.1
- (M145) -FUSE BLOCK-JUNCTION BOX (J/B) NO.2
- (M4), (B4) -ELECTRICAL UNITS

TIVM0496E

# POWER WINDOW SYSTEM

GW-WINDOW-02

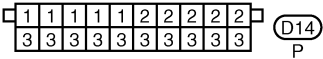
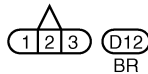
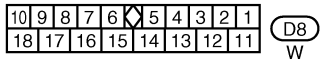
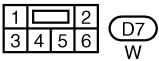
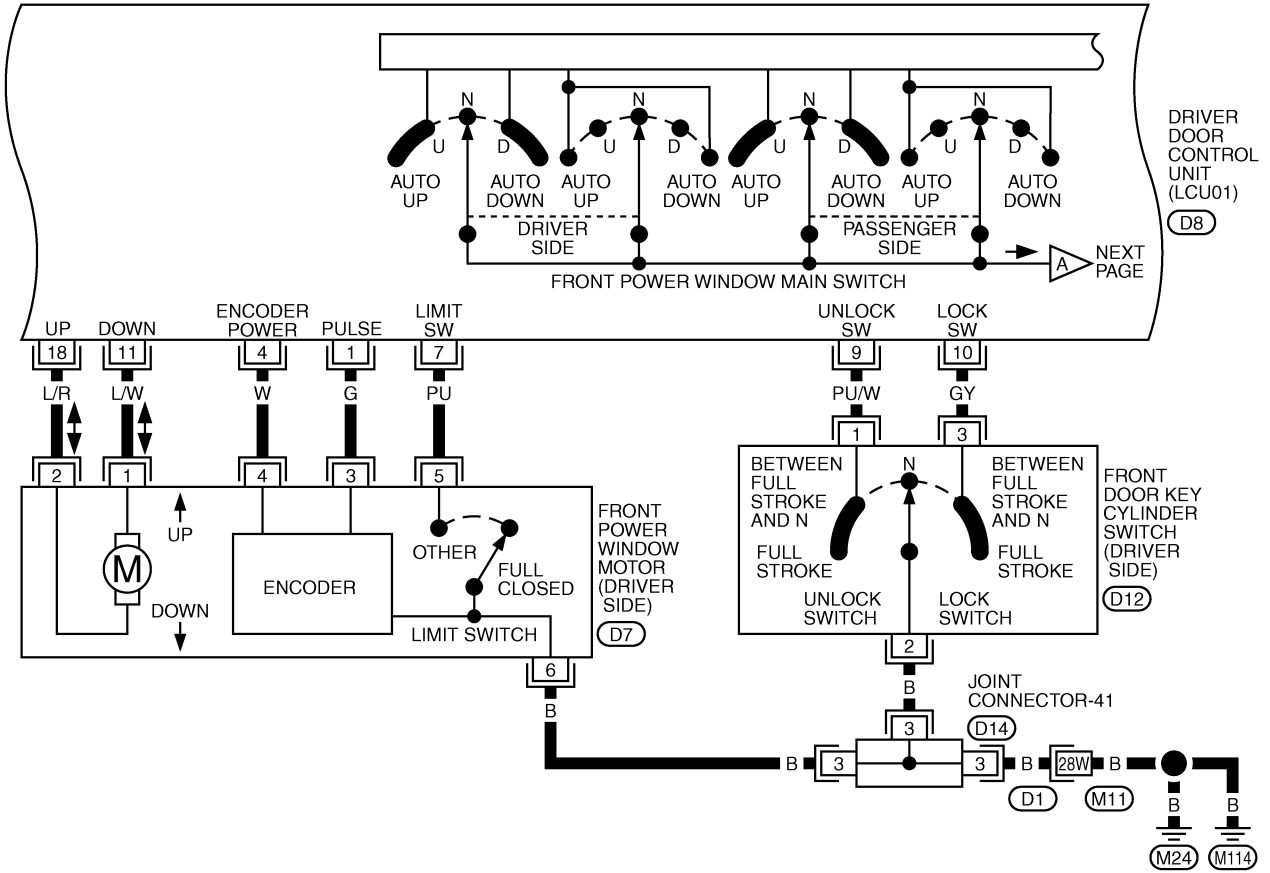

REFER TO THE FOLLOWING.

(D1) -SUPER MULTIPLE JUNCTION (SMJ)

# POWER WINDOW SYSTEM

GW-WINDOW-03

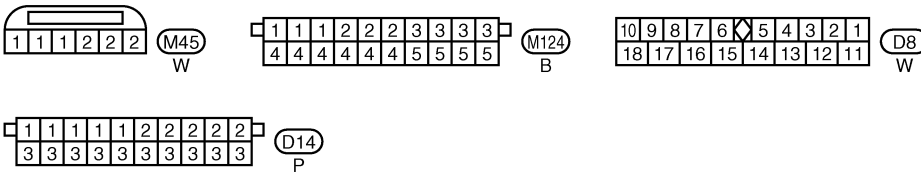
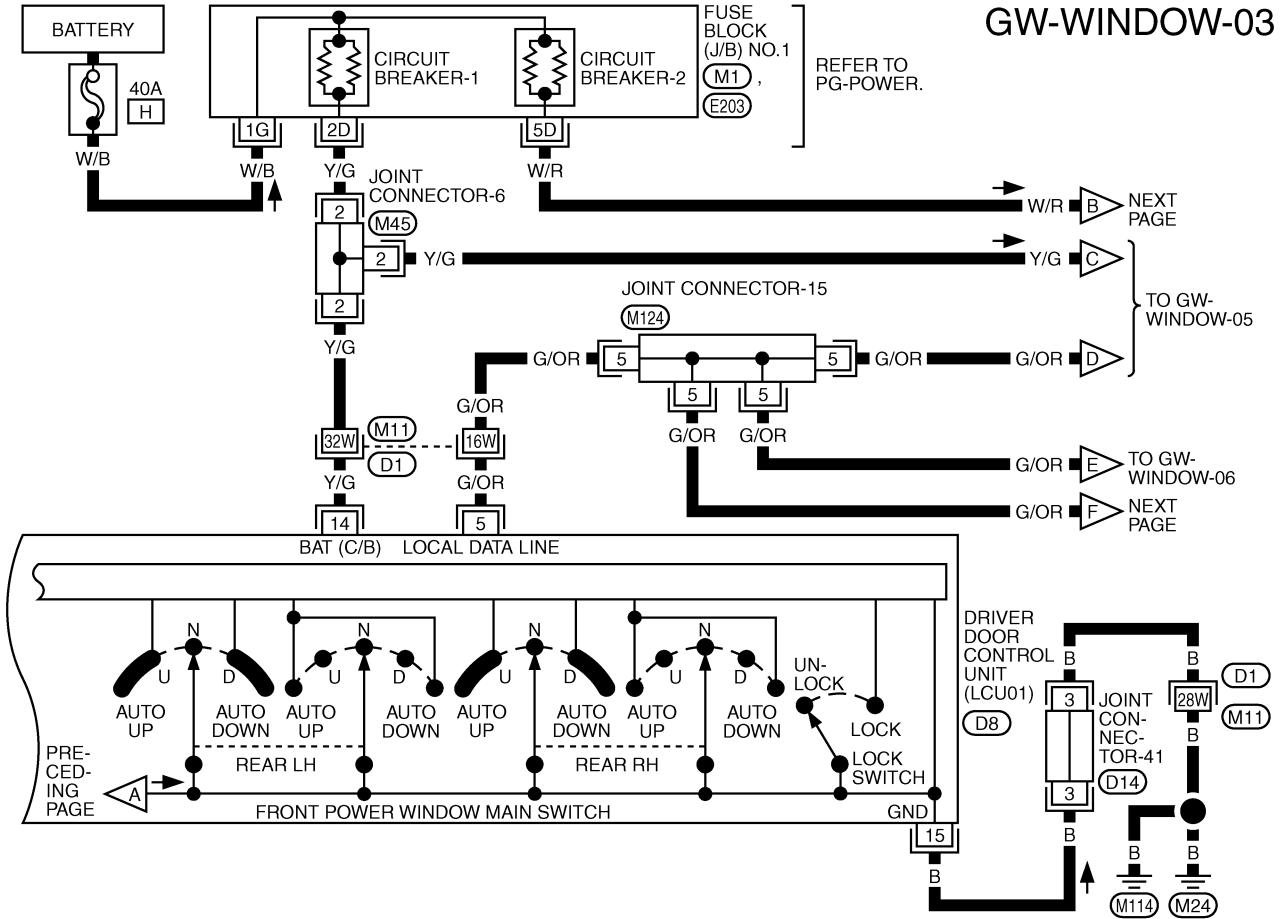

REFER TO THE FOLLOWING.

- (D1) -SUPER MULTIPLE JUNCTION (SMJ)
- (M1), (E203) -FUSE BLOCK-JUNCTION BOX (J/B) NO.1

TIWM0210E

# POWER WINDOW SYSTEM

GW-WINDOW-04

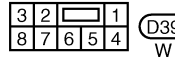
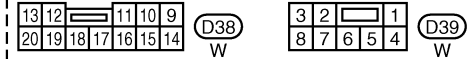
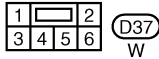
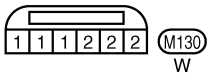
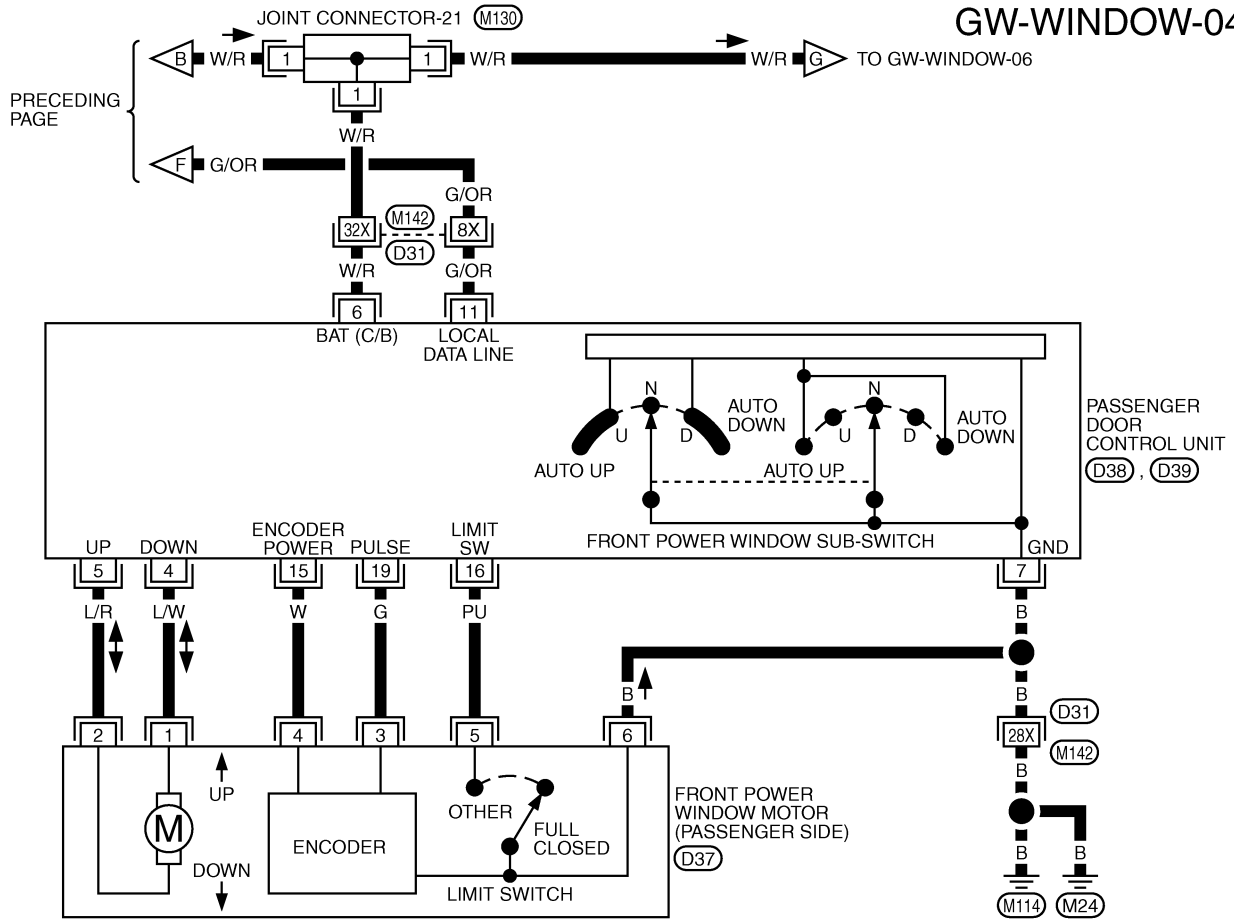

REFER TO THE FOLLOWING.

(D31) -SUPER MULTIPLE JUNCTION (SMJ)

# POWER WINDOW SYSTEM

GW-WINDOW-05

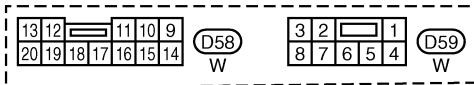
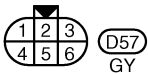
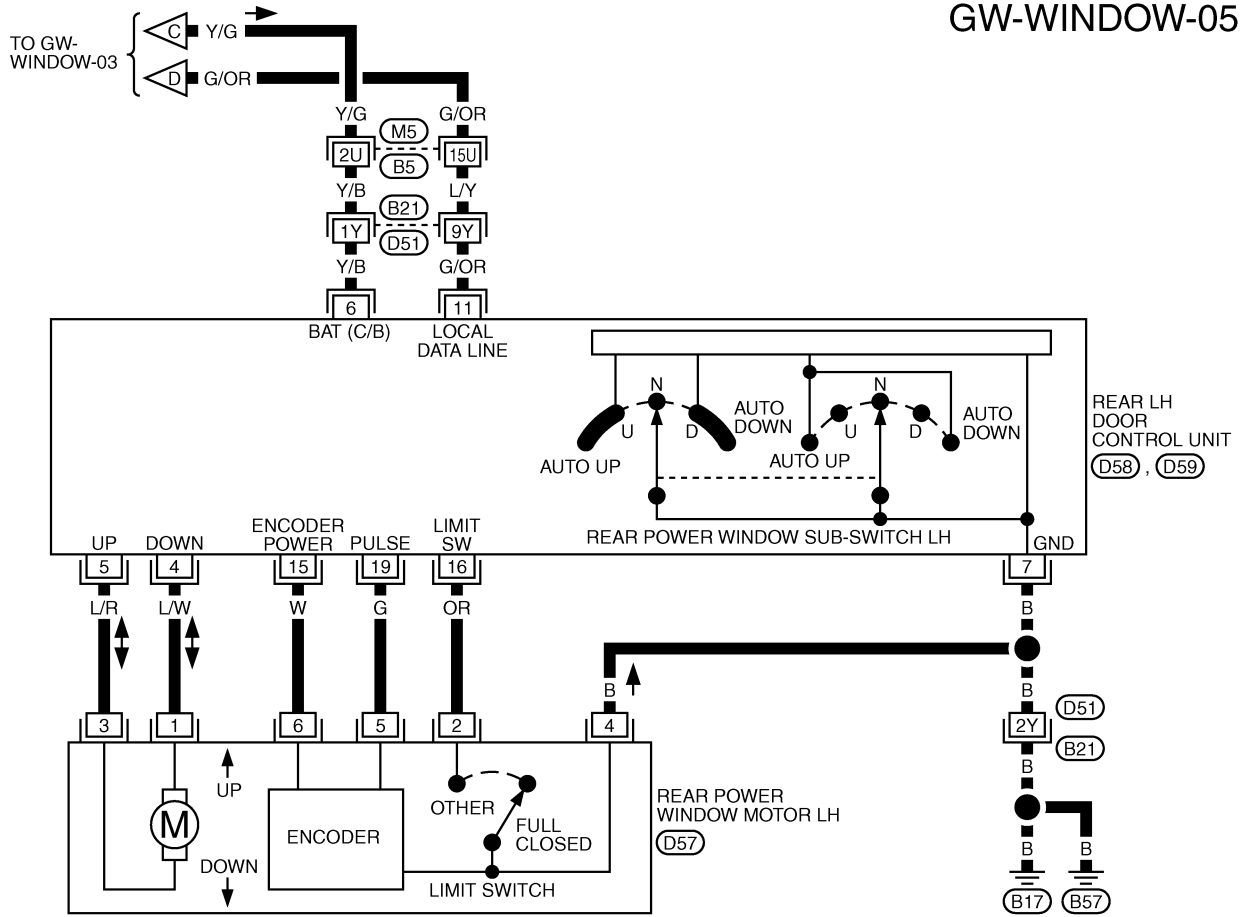

REFER TO THE FOLLOWING.  
 (M5), (B21) -SUPER MULTIPLE JUNCTION (SMJ)

TIVM0499E

# POWER WINDOW SYSTEM

GW-WINDOW-06

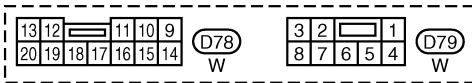
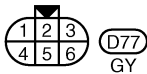
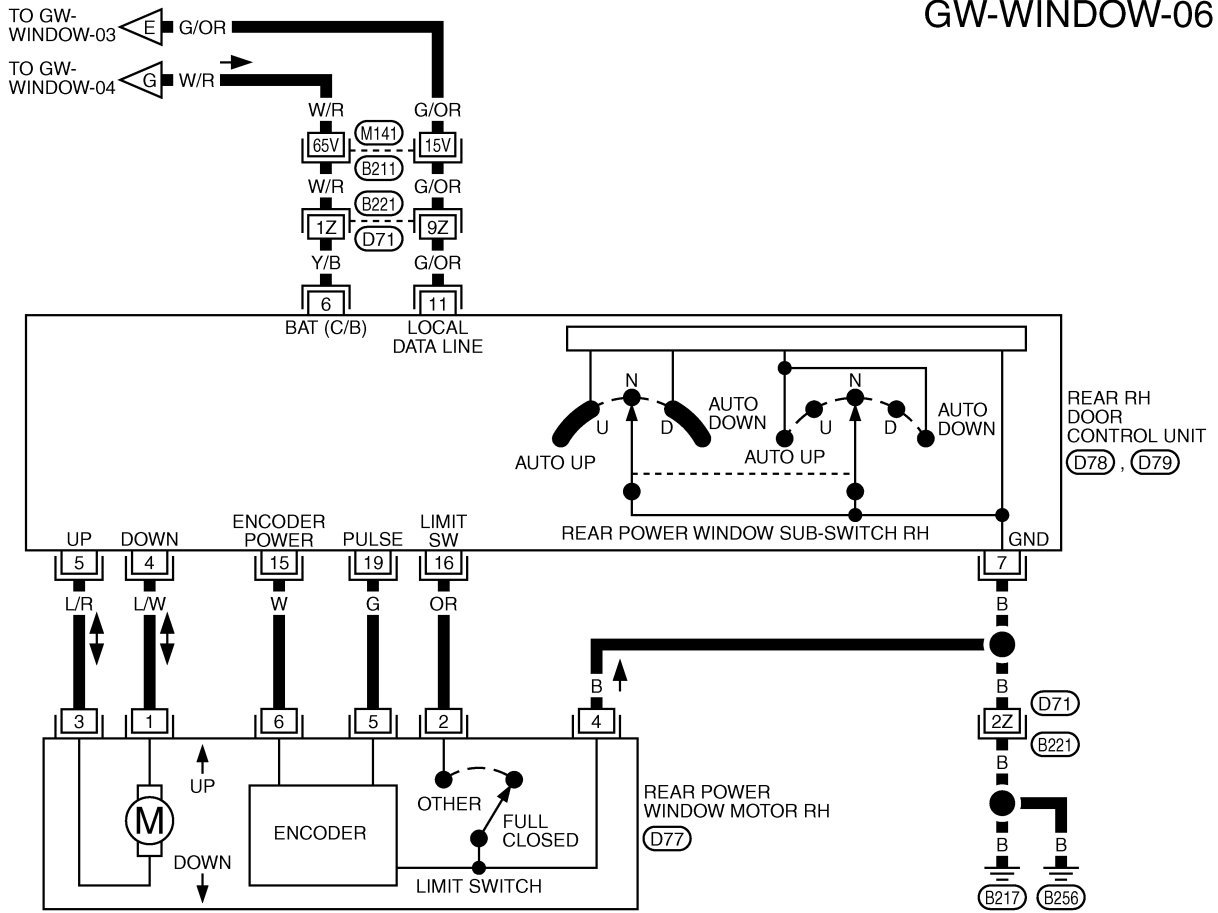

REFER TO THE FOLLOWING.  
 (B211), (B221) -SUPER MULTIPLE JUNCTION (SMJ)

TIWM0500E



# POWER WINDOW SYSTEM

## Terminals and Reference Value for Driver Door Control Unit

EIS000UY

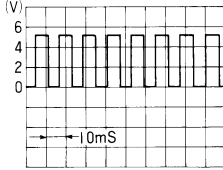
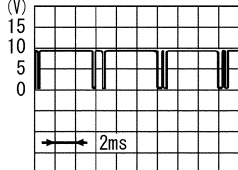
TERMI- NAL	WIRE COLOR	ITEM	CONDITION	Voltage (V) (Approx.)
1	G	Encoder pulse signal	When power window motor operates	 <p style="text-align: right; font-size: small;">OCC3383D</p>
4	W	Encoder power supply	When ignition switch ON or power window timer operates	10
5	G/OR	Local communication	When ignition switch ON or power window timer operates	 <p style="text-align: right; font-size: small;">SIIA0591J</p>
7	PU	Limit switch signal	Driver side door window is in a position between fully-open and just before fully-closed position (ON)	0
			Driver side door window is in a position between just before fully-closed position and fully-closed position (OFF)	5
8	G/W	Data line A-3	—	—
9	PU/W	Door key cylinder unlock switch	OFF (Neutral) → ON (Unlock)	5 → 0
10	GY	Door key cylinder lock switch	OFF (Neutral) → ON (Lock)	5 → 0
11	L/W	Power window motor DOWN signal	When power window motor DOWN operates	Battery voltage
14	Y/G	Power source (Fusible link)	—	Battery voltage
15	B	Ground	—	0
18	L/R	Power window motor UP signal	When power window motor UP operates	Battery voltage

## Terminals and Reference Value for Passenger, Rear LH, RH Door Control Unit

EIS0014K

TERMI- NAL	WIRE COLOR	ITEM	CONDITION	Voltage (V) (Approx.)
4	L/W	Power window motor DOWN signal	When power window motor DOWN operates	Battery voltage
5	L/R	Power window motor UP signal	When power window motor UP operates	Battery voltage
6	Y/B (W/R)	Power source (FUSE)	—	Battery voltage
7	B	Ground	—	0

# POWER WINDOW SYSTEM

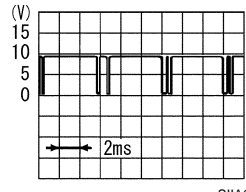
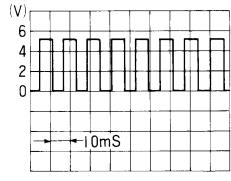
TERMI-NAL	WIRE COLOR	ITEM	CONDITION	Voltage (V) (Approx.)
11	G/OR	Local communication	When ignition switch ON or power window timer operates	 <p style="text-align: right; font-size: small;">SIIA0591J</p>
15	W	Encoder power supply	When ignition switch ON or power window timer operates	10
16	OR (PU)	Limit switch signal	Door window is between fully-open and just before fully-closed position (ON)	0
			Door window is between just before fully-closed position and fully-closed position (OFF)	5
19	G	Encoder pulse signal	When power window motor operates	 <p style="text-align: right; font-size: small;">OCC3383D</p>

(): Passenger door control unit

## Trouble Diagnosis Symptom Chart

EIS000NW

- Check that other systems using the signal of the following systems operate normally.

Symptom	Diagnostic procedure.	Refer page
None of the power windows can be operated using any switch.	Check the following. <ul style="list-style-type: none"> <li>● 40A fusible link (letter H, located in fuse and fusible link box)</li> <li>● harness for open and short between BCM and power window main switch (LCU01). Refer to <a href="#">LAN-7, "On Board Diagnosis"</a></li> <li>● Power window main switch (LCU01)</li> <li>● BCM</li> </ul>	—
Driver side power window cannot be operated but other windows can be operated.	1. Driver door control unit circuit check.	<a href="#">GW-42</a>
	2. Front power window motor (driver side) circuit check	<a href="#">GW-30</a>
	3. Replace driver door control unit (LCU1)	<a href="#">EI-36</a>
Passenger side power window cannot be operated but other windows can be operated.	1. Passenger door control unit circuit check.	<a href="#">GW-42</a>
	2. Front power window motor (passenger side) circuit check.	<a href="#">GW-31</a>
	3. Replace passenger door control unit.	<a href="#">EI-36</a>
Rear LH or RH power window cannot be operated but other windows can be operated.	1. Rear door control unit (LH or RH) circuit.	<a href="#">GW-43</a>
	2. Rear power window motor (LH or RH) circuit check.	<a href="#">GW-32</a>
	3. Replace rear LH or RH door control unit.	<a href="#">EI-36</a>
Power windows except driver's side window cannot be operated using power window main switch.	1. Communication signal circuit check.	<a href="#">GW-28</a>
	2. Replace the power window main switch.	—

# POWER WINDOW SYSTEM

Symptom	Diagnostic procedure.	Refer page	
Anti-pinch system does not operate normally (driver side).	1. Limit switch is adjusted.	<a href="#">GW-54</a>	A
	2. Limit switch check (driver side)	<a href="#">GW-33</a>	
	3. Encoder circuit check (driver side)	<a href="#">GW-37</a>	B
	4. Door window sliding part malfunction. ● A foreign material adheres to window glass or glass run rubber. ● Glass run rubber wear or deformation. ● Sash is tilted too much, or not enough.	—	C
	5. Replace driver door control unit (LCU1).	<a href="#">EI-36</a>	D
Anti-pinch system does not operate normally (passenger side).	1. Limit switch is adjusted.	<a href="#">GW-54</a>	
	2. Limit switch check (passenger side).	<a href="#">GW-34</a>	E
	3. Encoder circuit check (passenger side).	<a href="#">GW-38</a>	
	4. Door window sliding part malfunction. ● A foreign material adheres to window glass or glass run rubber. ● Glass run rubber wear or deformation. ● Sash is tilted too much, or not enough.	—	F
	5. Replace passenger side door control unit.	<a href="#">EI-36</a>	G
Anti-pinch system does not operate normally (rear RH or LH).	1. Limit switch is adjusted.	<a href="#">GW-57</a>	
	2. Limit switch check (rear LH or RH).	<a href="#">GW-35</a>	H
	3. Encoder circuit check (rear LH or RH).	<a href="#">GW-40</a>	
	4. Door window sliding part malfunction. ● A foreign material adheres to window glass or glass run rubber. ● Glass run rubber wear or deformation. ● Sash is tilted too much, or not enough.	—	J
Power window timer function does not operate properly.	1. Door switch check.	<a href="#">GW-44</a>	
	2. Check the following ● harness for open and short between BCM and power window main switch (LCU01). Refer to <a href="#">LAN-7, "On Board Diagnosis"</a> ● BCM	—	K L

GW

# POWER WINDOW SYSTEM

EIS000NX

## Communication Signal Circuit Check

### 1. CHECK COMMUNICATION CIRCUIT

1. Turn ignition switch OFF.
2. Disconnect connectors for driver door control unit (LCU01) and malfunctioning door control unit.
3. Check continuity between driver door control unit (LCU01) connector terminal 5 and malfunctioning door control unit connector terminal 11.

Passenger door control unit				
Terminals				Continuity
Driver door control unit		Passenger door control unit		
Connector	Terminal (Wire color)	Connector	Terminal (Wire color)	
D8	5 (G/OR)	D38	11 (G/OR)	Yes

Rear door control unit LH or RH				
Terminals				Continuity
Driver door control unit		Rear LH or RH door control unit		
Connector	Terminal (Wire color)	Connector	Terminal (Wire color)	
D8	5 (G/OR)	D58 (LH) D78 (RH)	11 (G/OR)	Yes

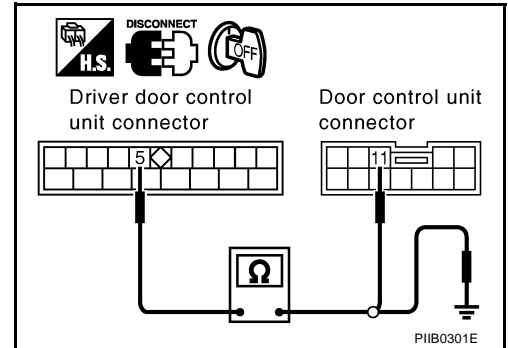

4. Check continuity between driver door control unit (LCU01) connector terminal 5 and ground.

**5 (G/OR) – Ground : Continuity should not exist.**

OK or NG

- OK >> GO TO 2  
 NG >> Repair or replace harness

# POWER WINDOW SYSTEM

## 2. CHECK COMMUNICATION SIGNAL

1. Connect driver door control unit (LCU01) and malfunctioning door control unit connector.
2. Check the signal between malfunctioning door control unit connector terminal 11 and ground with oscilloscope.

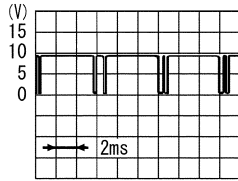
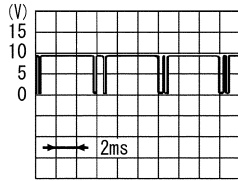
Passenger door control unit			Signal ( )Reference value
Terminals			
(+)		(-)	 SIIA0591J
Connector	Terminal (Wire color)	Ground	
D38	11 (G/OR)		
Rear LH, RH door control unit			
Terminals			 SIIA0591J
(+)		(-)	
Connector	Terminal (Wire color)	Ground	
D58 (LH) D78 (RH)	11 (G/OR)		

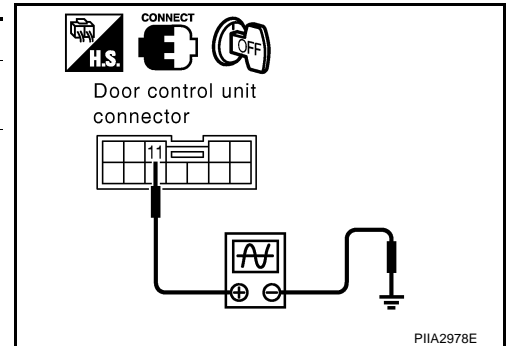

### OK or NG

- OK >> Communication signal is OK.
- NG >> ● All door control unit (passenger, rear LH or RH) connected are NG.→ Replace driver door control unit (LCU01).
- Any of door control unit (passenger, rear LH or RH) connected are NG.→ Replace malfunctioning door control unit.

# POWER WINDOW SYSTEM

## Front Power Window Motor (Driver Side) Circuit Check

E/S000JB

### 1. CHECK DRIVER DOOR CONTROL UNIT OUTPUT SIGNAL

1. Turn ignition switch ON.
2. Check voltage between front power window motor (driver side) connector and ground.

Connector	Terminals (Wire color)		Condition	Voltage (V) (Approx.)
	(+)	(-)		
D7	1 (L/W)	Ground	Window is closing	0
			Window is opening	Battery voltage
	2 (L/R)		Window is closing	Battery voltage
			Window is opening	0

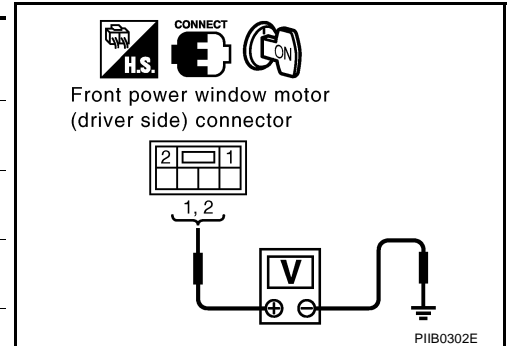

OK or NG

- OK >> Replace front power window motor (driver side).  
 NG >> GO TO 2

### 2. CHECK DRIVER POWER WINDOW MOTOR CIRCUIT

1. Turn ignition switch OFF.
2. Disconnect front power window motor (driver side) connector and driver door control unit (LCU01) connector.
3. Check continuity between front power window motor (driver side) connector D7 terminals 1, 2 and driver door control unit (LCU01) connector D8 terminals 11, 18.

**1 (L/W) – 11 (L/W) : Continuity should exist.**

**2 (L/R) – 18 (L/R) : Continuity should exist.**

4. Check continuity between front power window motor (driver side) connector D7 terminals 1, 2 and ground.

**1 (L/W) – Ground : Continuity should not exist.**

**2 (L/R) – Ground : Continuity should not exist.**

OK or NG

- OK >> Replace driver door control unit (LCU01).  
 NG >> Repair or replace harness between driver door control unit (LCU01) and front power window motor (driver side).

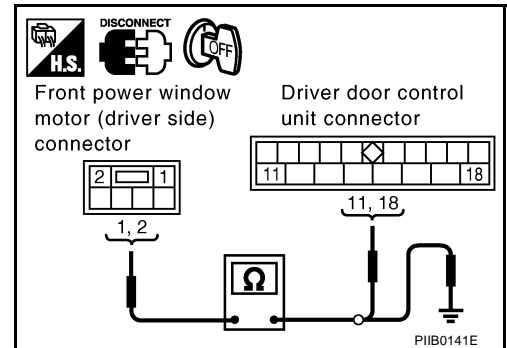

# POWER WINDOW SYSTEM

## Front Power Window Motor (Passenger Side) Circuit Check

E/S000JD

### 1. CHECK PASSENGER DOOR CONTROL UNIT OUTPUT SIGNAL

1. Turn ignition switch ON.
2. Check voltage between front power window motor (passenger side) connector and ground.

Connector	Terminals (Wire color)		Condition	Voltage (V) (Approx.)
	(+)	(-)		
D37	1 (L/W)	Ground	Window is closing	0
			Window is opening	Battery voltage
	2 (L/R)		Window is closing	Battery voltage
			Window is opening	0

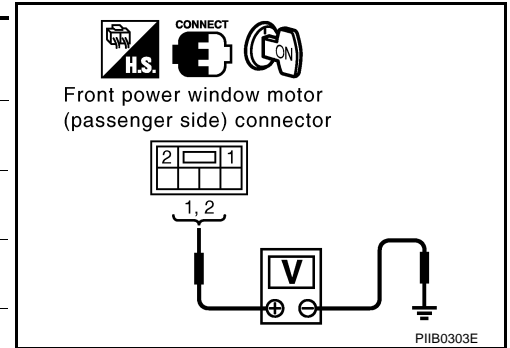

#### OK or NG

- OK >> Replace front power window motor (passenger side).  
 NG >> GO TO 2

### 2. CHECK FRONT POWER WINDOW MOTOR (PASSENGER SIDE) CIRCUIT

1. Turn ignition switch OFF.
2. Disconnect front power window motor (passenger side) and passenger door control unit connector.
3. Check continuity between front power window motor (passenger side) connector D37 terminals 1, 2 and passenger door control unit connector D39 terminals 4, 5.

- 1 (L/W) – 4 (L/W) :Continuity should exist.**  
**2 (L/R) – 5 (L/R) :Continuity should exist.**

4. Check continuity between front power window motor (passenger side) connector D37 terminals 1, 2 and ground.

- 1 (L/W) – Ground :Continuity should not exist.**  
**2 (L/R) – Ground :Continuity should not exist.**

#### OK or NG

- OK >> Replace passenger door control unit.  
 NG >> Repair or replace harness between front power window motor (passenger side) and passenger door control unit.

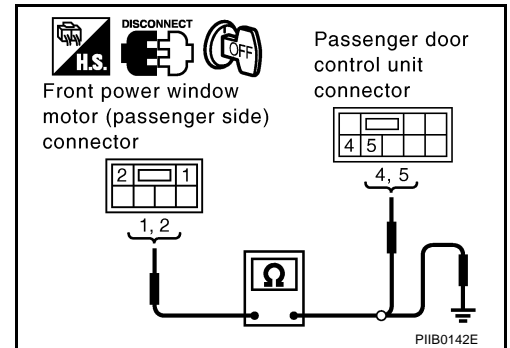

# POWER WINDOW SYSTEM

EIS000ZV

## Rear Power Window Motor (LH or RH) Circuit Check

### 1. CHECK REAR DOOR CONTROL UNIT LH OR RH OUTPUT SIGNAL

1. Turn ignition switch OFF.
2. Disconnect rear power window motor LH or RH.
3. Turn ignition switch ON.
4. Check voltage between rear power window motor LH or RH connector and ground.

Connector	Terminals (Wire color)		Condition	Voltage (V) (Approx.)
	(+)	(-)		
D57 (LH) D77 (RH)	1 (L/W)	Ground	Window is closing	0
			Window is opening	Battery voltage
	3 (L/R)		Window is closing	Battery voltage
			Window is opening	0

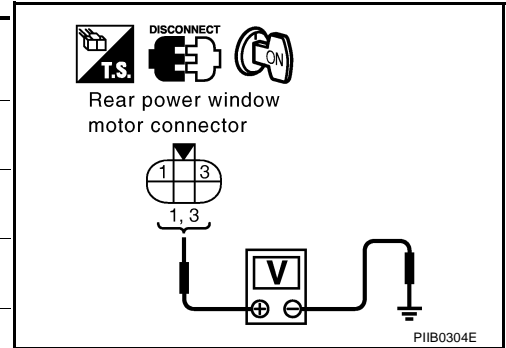

#### OK or NG

- OK >> Replace rear power window motor LH or RH.  
 NG >> GO TO 2

### 2. CHECK REAR POWER WINDOW MOTOR LH OR RH CIRCUIT

1. Turn ignition switch OFF.
2. Disconnect rear door control LH or RH unit connector.
3. Check continuity between rear power window motor LH or RH connector D57(LH) or D77(RH) terminals 1, 3 and rear door control unit LH or RH connector D59(LH) or D79(RH) terminals 4, 5.

**1 (L/W) – 4 (L/W) :Continuity should exist.**

**3 (L/R) – 5 (L/R) :Continuity should exist.**

4. Check continuity between rear power window motor LH or RH connector D59(LH) or D79(RH) terminals 1, 3 and ground.

**1 (L/W) – Ground :Continuity should not exist.**

**3 (L/R) – Ground :Continuity should not exist.**

#### OK or NG

- OK >> Replace rear door control unit LH or RH.  
 NG >> Repair or replace harness between rear door control unit LH or RH and rear power window motor LH or RH.

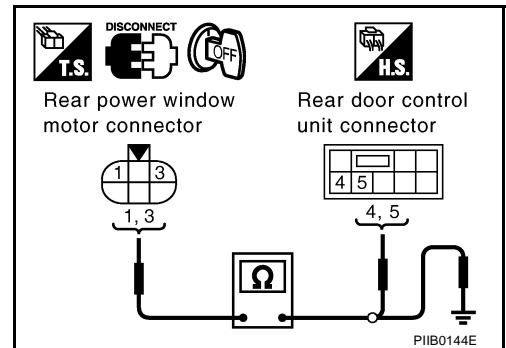



# POWER WINDOW SYSTEM

E/IS000JE

## Limit Switch Check (Driver Side)

### 1. LIMIT SWITCH SIGNAL CHECK

1. Turn the ignition switch ON.
2. Check voltage between front power window motor (driver side) connector and ground.

Connector	Terminals (Wire color)		Condition	Voltage (V) (Approx.)
	(+)	(-)		
D7	5 (PU)	Ground	Driver side door window is between fully-open and just before fully-closed position (ON)	0
			Driver side door window is between just before fully-closed position and fully-closed position (OFF)	5

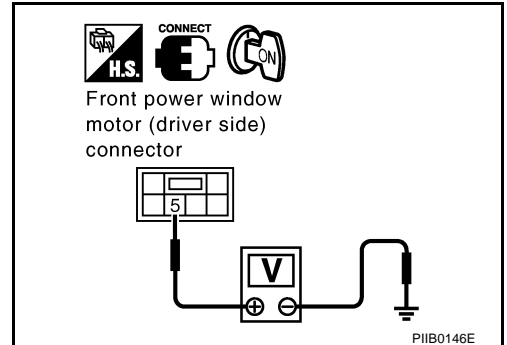

OK or NG

- OK >> Limit switch (driver side) is OK.  
 NG >> GO TO 2

### 2. LIMIT SWITCH GROUND CHECK

1. Turn ignition switch OFF.
2. Disconnect front power window motor (driver side) connector.
3. Check continuity between front power window motor (driver side) connector D7 terminal 6 and ground.

**6 (B) – Ground :Continuity should exist.**

OK or NG

- OK >> GO TO 3  
 NG >> Repair or replace harness.

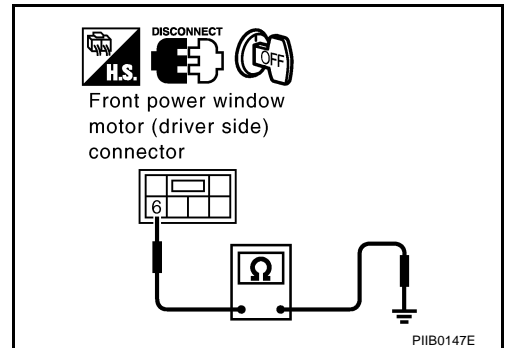

### 3. FRONT POWER WINDOW MOTOR (DRIVER SIDE) CIRCUIT CHECK

1. Disconnect driver door control unit (door LCU01) connector.
2. Check continuity between power window motor (driver side) connector D7 terminal 5 and driver door control unit (LCU01) connector D8 terminal 7.

**5 (PU) – 7 (PU) :Continuity should exist.**

3. Check continuity between power window motor (driver side) connector D7 terminal 5 and ground.

**5 (PU) – Ground :Continuity should not exist.**

OK or NG

- OK >> GO TO 4.  
 NG >> Repair or replace harness between driver door control unit (LCU01) and front power window motor (driver side).

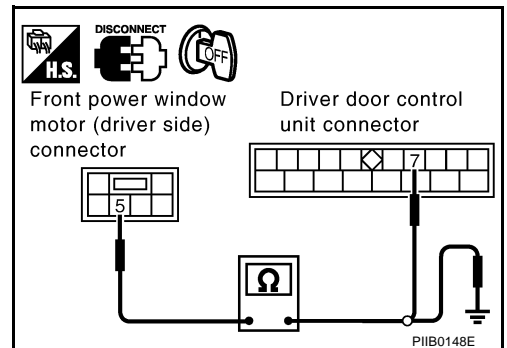

# POWER WINDOW SYSTEM

## 4. LIMIT SWITCH SIGNAL CHECK

1. Connect driver door control unit (LCU01) connector.
2. Turn ignition switch ON.
3. Check voltage between front power window motor (driver side) connector D7 terminal 5 and ground.

**5 (PU) – Ground : Approx. 5V**

OK or NG

- OK >> Check the condition of the harness and the connector.  
 NG >> Replace front power window motor (driver side).

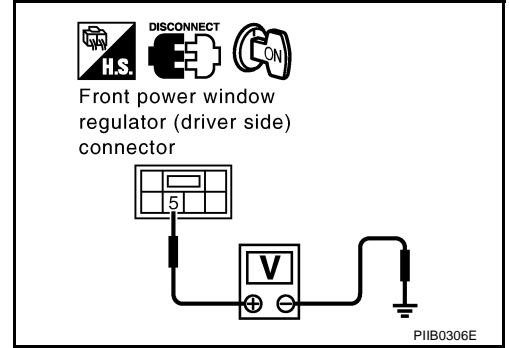

EIS003PU

## Limit Switch Check (Passenger Side)

### 1. LIMIT SWITCH SIGNAL CHECK

1. Turn the ignition switch ON.
2. Check voltage between front power window motor (passenger side) connector and ground.

Connector	Terminals (Wire color)		Condition	Voltage (V) (Approx.)
	(+)	(-)		
D37	5 (PU)	Ground	Passenger side door window is between fully-open and just before fully-closed position (ON)	0
			Passenger side door window is between just before fully-closed position and fully-closed position (OFF)	5

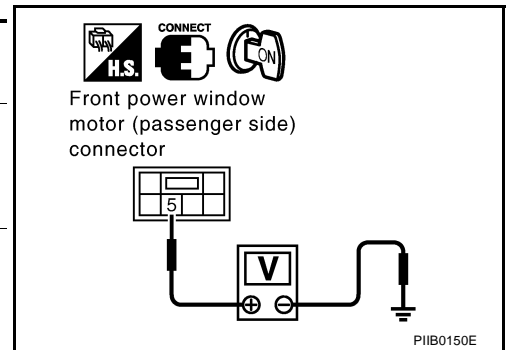

OK or NG

- OK >> Limit switch (passenger side) is OK.  
 NG >> GO TO 2

### 2. LIMIT SWITCH GROUND CHECK

1. Turn ignition switch OFF.
2. Disconnect front power window motor (passenger side) connector.
3. Check continuity between front power window motor (passenger side) connector D37 terminal 6 and ground.

**6 (B) – Ground : Continuity should exist.**

OK or NG

- OK >> GO TO 3  
 NG >> Repair or replace harness.

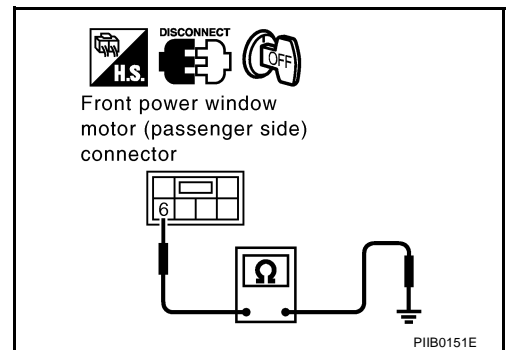

# POWER WINDOW SYSTEM

## 3. CHECK POWER WINDOW MOTOR CIRCUIT

1. Disconnect passenger door control unit connector.
2. Check continuity between front power window motor (passenger side) connector D37 terminal 5 and passenger door control unit connector D38 terminal 16.

**5 (PU) – 16 (PU) :Continuity should exist.**

3. Check continuity between front power window motor (passenger side) connector D37 terminal 5 and ground.

**5 (PU) – Ground :Continuity should not exist.**

### OK or NG

OK >> GO TO 4.

NG >> Repair or replace harness between passenger door control unit and front power window motor (passenger side)

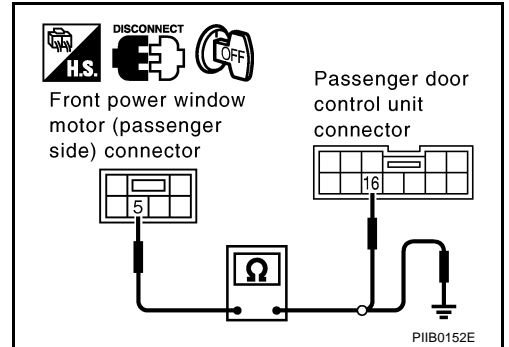

## 4. LIMIT SWITCH CHECK

1. Connect passenger door control unit connector.
2. Turn ignition switch ON.
3. Check voltage between front power window motor (passenger side) connector D37 terminal 5 and ground.

**5 (PU) – Ground : Approx. 5V**

### OK or NG

OK >> Check the condition of the harness and the connector.

NG >> Replace front power window motor (passenger side).

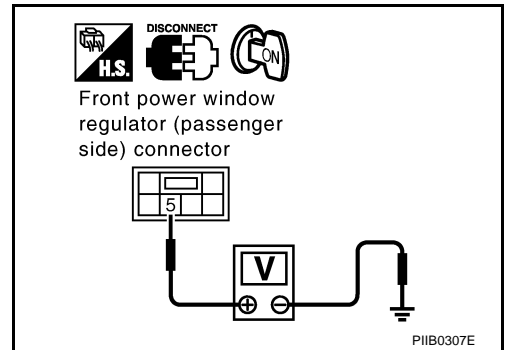

## Limit Switch Circuit Check (Rear LH or RH)

### 1. LIMIT SWITCH SIGNAL CHECK

1. Turn the ignition switch ON.
2. Check voltage between rear door control unit connector D58(LH) or D78(RH) terminal and ground.

Connector	Terminals (Wire color)		Condition	Voltage (V) (Approx.)
	(+)	(-)		
D58 (LH) D78 (RH)	16 (OR)	Ground	Rear door window is between fully-open and just before fully-closed position (ON)	0
			Rear door window is between just before fully-closed position and fully-closed position (OFF)	5

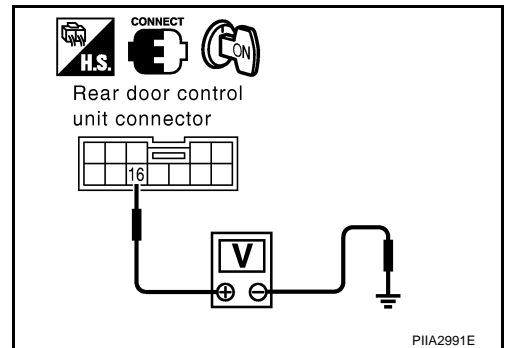

### OK or NG

OK >> Limit switch rear LH or RH is OK.

NG >> GO TO 2

# POWER WINDOW SYSTEM

## 2. LIMIT SWITCH GROUND CHECK

1. Turn ignition switch OFF.
2. Disconnect rear power window motor LH or RH connector.
3. Check continuity between rear power window motor LH or RH connector D57(LH) or D77(RH) terminal 4 and ground.

**4 (B) – Ground :Continuity should exist.**

OK or NG

- OK >> GO TO 3  
NG >> Repair or replace harness.

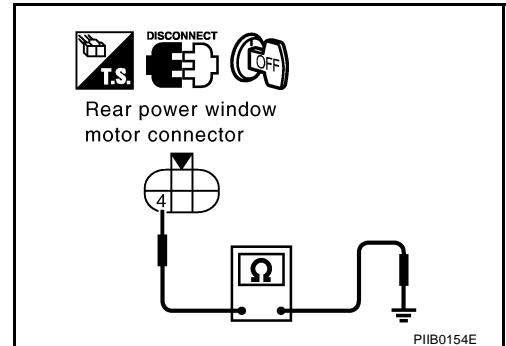

## 3. CHECK REAR POWER WINDOW MOTOR CIRCUIT

1. Disconnect rear door control unit LH or RH connector.
2. Check continuity between rear power window motor LH or RH connector D57(LH), D77(RH) terminal 2 and rear door control unit LH or RH connector D58(LH), D78(RH) terminal 16.

**2 (OR) – 16(OR) :Continuity should exist.**

3. Check continuity between rear power window motor connector D57(LH), D77(RH) terminal 2 and ground.

**2 (OR) – Ground :Continuity should not exist.**

OK or NG

- OK >> GO TO 4.  
NG >> Repair or replace harness between rear door control unit LH or RH and rear power window motor LH or RH.

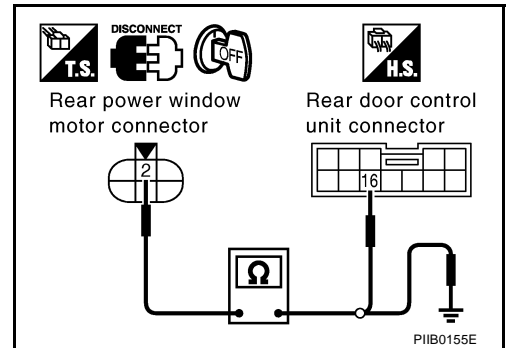

## 4. LIMIT SWITCH OUTPUT SIGNAL CHECK

1. Connect rear door control unit connector.
2. Turn ignition switch ON.
3. Check voltage between rear door control unit LH or RH connector D58 (LH), D78 (RH) terminal 16 and ground.

**16 (OR) – Ground :Approx 5V**

OK or NG

- OK >> Replace rear power window motor LH or RH.  
NG >> Replace rear door control unit LH or RH.

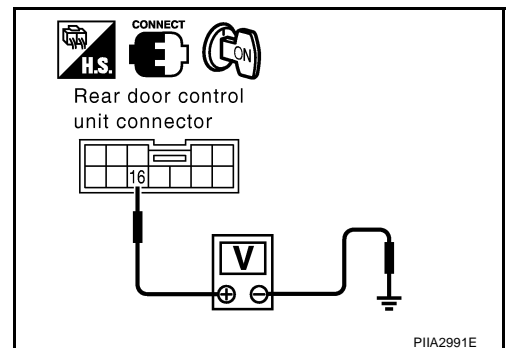

# POWER WINDOW SYSTEM

## Encoder Circuit Check (Driver Side)

EIS000JG

### 1. CHECK FRONT POWER WINDOW MOTOR (DRIVER SIDE) CIRCUIT

1. Turn ignition switch ON.
2. Check voltage between front power window motor (driver side) connector D7 terminal 4 and ground.

**4 (W) – Ground :Approx. 10V**

OK or NG

OK >> GO TO 3  
NG >> GO TO 2

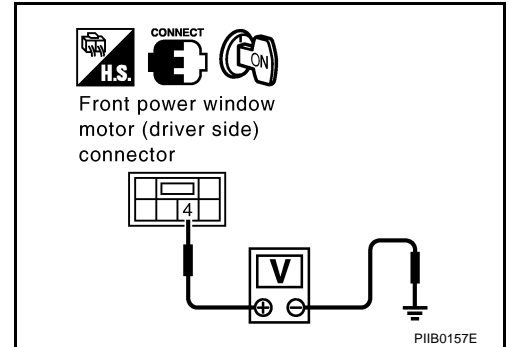

### 2. CHECK HARNESS CONTINUITY

1. Turn ignition switch OFF.
2. Disconnect driver door control unit (LCU01) and front power window motor (driver side) connector.
3. Check continuity between driver door control unit (LCU01) connector D8 terminal 4 and front power window motor (driver side) connector D7 terminal 4.

**4 (W) – 4 (W) :Continuity should exist.**

OK or NG

OK >> Replace driver door control unit (LCU01).  
NG >> Repair or replace harness between driver door control unit (LCU01) and front power window motor (driver side).

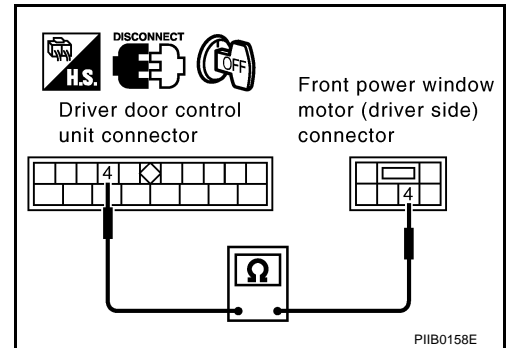

### 3. CHECK ENCODER GROUND

1. Turn ignition switch OFF.
2. Disconnect front power window motor (driver side) connector.
3. Check continuity between front power window motor (driver side) connector D7 terminal 6 and ground.

**6 (B) – Ground :Continuity should exist.**

OK or NG

OK >> GO TO 4  
NG >> Repair or replace harness.

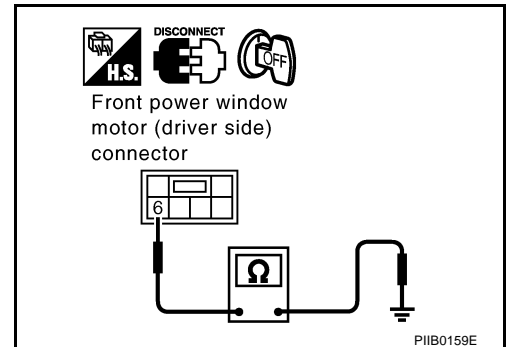

# POWER WINDOW SYSTEM

## 4. CHECK ENCODER SIGNAL

1. Connect front power window motor (driver side) connector.
2. Turn ignition switch ON.
3. Check the signal between driver door control unit (LCU01) connector and ground with oscilloscope.

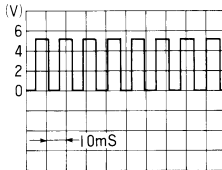
Terminals		Condition	Signal (Reference value)
(+)	(-)		
Connector	Terminal (Wire color)		
D8	1 (G)	Ground	
		Opening	

OCC3383D

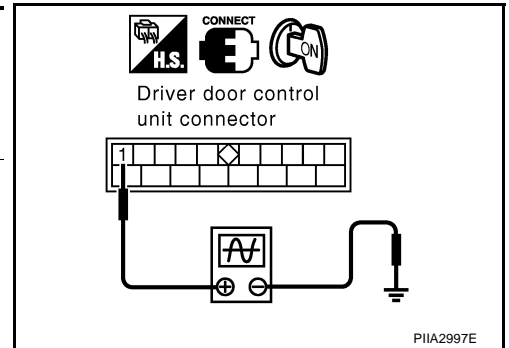

OK or NG

OK >> Encoder function is OK.

NG >> GO TO 5

## 5. CHECK ENCODER CIRCUIT

1. Turn ignition switch OFF.
2. Disconnect driver door control unit and front power window motor (driver side) connector.
3. Check continuity between driver door control unit (LCU01) connector D8 terminal 1 and front power window motor (driver side) connector D7 terminal 3.

**1 (G) – 3 (G) :Continuity should exist.**

OK or NG

OK >> Replace front power window motor (driver side).

NG >> Repair or replace harness between driver door control unit (LCU01) and front power window motor (driver side).

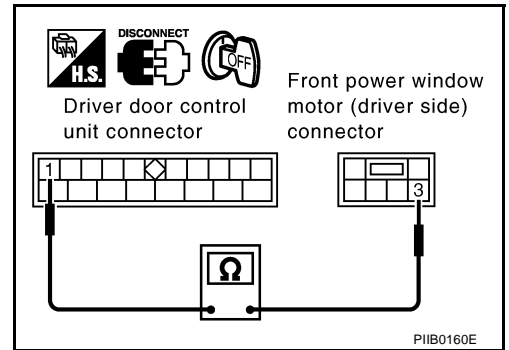

## Encoder Circuit Check (Passenger Side)

### 1. CHECK FRONT POWER WINDOW MOTOR (PASSENGER SIDE) CIRCUIT

1. Turn ignition switch ON.
2. Check voltage between front power window motor (passenger side) connector D37 terminal 4 and ground.

**4 (W) – Ground :Approx. 10V**

OK or NG

OK >> GO TO 3

NG >> GO TO 2

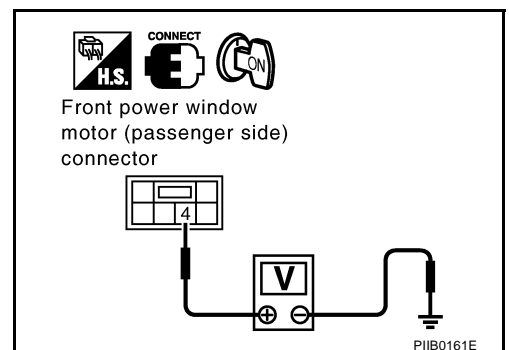

# POWER WINDOW SYSTEM

## 2. CHECK HARNESS CONTINUITY

1. Turn ignition switch OFF.
2. Disconnect passenger door control unit and front power window motor (passenger side) connector.
3. Check continuity between passenger door control unit connector D38 terminal 15 and front power window motor (passenger side) connector D37 terminal 4.

**15 (W) – 4 (W) :Continuity should exist.**

### OK or NG

- OK >> Replace passenger door control unit.  
 NG >> Repair or replace harness between passenger door control unit and front power window motor (passenger side).

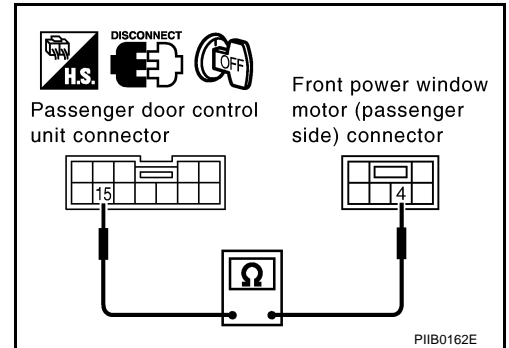

## 3. CHECK ENCODER GROUND

1. Turn ignition switch OFF.
2. Disconnect front power window motor (passenger side) connector.
3. Check continuity between front power window motor (passenger side) connector D37 terminal 6 and ground.

**6 (B) – Ground :Continuity should exist.**

### OK or NG

- OK >> GO TO 4  
 NG >> Repair or replace harness.

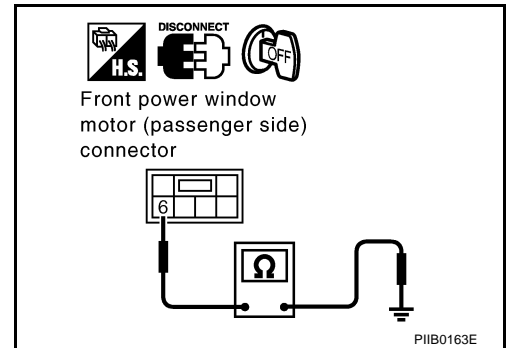

## 4. CHECK ENCODER SIGNAL

1. Connect front power window motor (passenger side) connector.
2. Turn ignition switch ON.
3. Check the signal between passenger door control unit connector and ground with oscilloscope.

Terminals		Condition	Signal (Reference value)
(+)	(-)		
Connector	Terminal (Wire color)		
D38	19 (G)	Ground	
		Opening	

OCC3383D

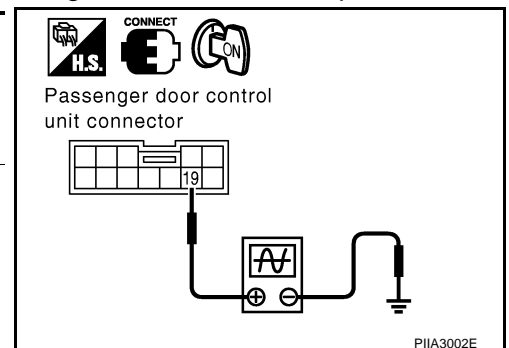

### OK or NG

- OK >> Encoder function is OK.  
 NG >> GO TO 5

# POWER WINDOW SYSTEM

## 5. CHECK ENCODER CIRCUIT

1. Turn ignition switch OFF.
2. Disconnect passenger door control unit and front power window motor (passenger side) connector.
3. Check continuity between passenger door control unit connector D38 terminal 19 and front power window motor (passenger side) connector D37 terminal 3.

**19 (G) – 3 (G) :Continuity should exist.**

### OK or NG

- OK >> Replace front power window motor (passenger side).  
NG >> Repair or replace harness between passenger door control unit and front power window motor (passenger side).

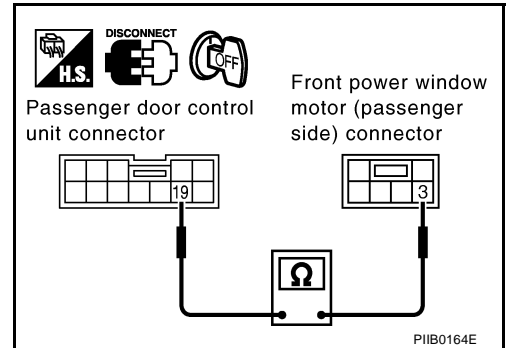

## Encoder Circuit Check (Rear LH or RH)

### 1. CHECK REAR POWER WINDOW MOTOR CIRCUIT

1. Turn ignition switch OFF.
2. Disconnect rear power window motor LH or RH connector.
3. Turn ignition switch ON.
4. Check voltage between rear power window motor LH or RH connector D57(LH) or D77(RH) terminal 6 and ground.

**6 (W) – Ground :Approx. 10V**

### OK or NG

- OK >> GO TO 3  
NG >> GO TO 2

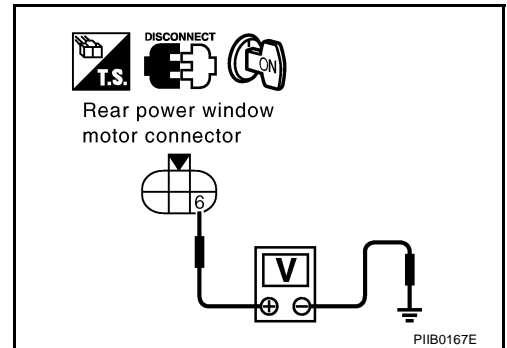

## 2. CHECK HARNESS CONTINUITY

1. Turn ignition switch OFF.
2. Disconnect rear door control unit LH or RH and rear power window motor LH or RH connector.
3. Check continuity between rear door control unit LH or RH connector D58(LH) or D78(RH) terminal 15 and rear power window motor LH or RH connector D57(LH) or D77(RH) terminal 6.

**15 (W) – 6 (W) :Continuity should exist.**

### OK or NG

- OK >> Replace rear door control unit LH or RH.  
NG >> Repair or replace harness between rear door control unit LH or RH and rear power window motor LH or RH.

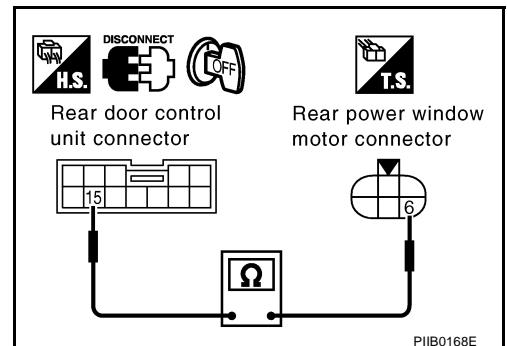



# POWER WINDOW SYSTEM

## 3. CHECK ENCODER GROUND

1. Turn ignition switch OFF.
2. Disconnect rear power window motor LH or RH connector.
3. Check continuity between rear power window motor LH or RH connector D57(LH) or D77(RH) terminal 4 and ground.

**4 (B) – Ground :Continuity should exist.**

OK or NG

- OK >> GO TO 4  
 NG >> Repair or replace harness.

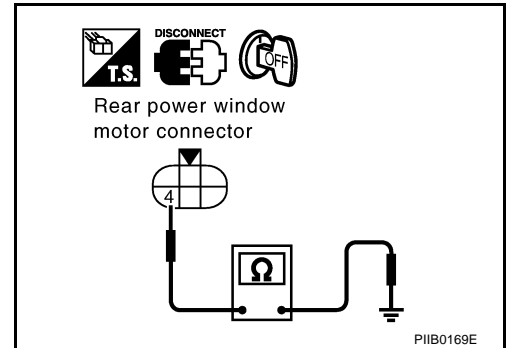

## 4. CHECK ENCODER SIGNAL

1. Connect rear power window motor LH or RH connector.
2. Turn ignition switch ON.
3. Check the signal between rear door control unit LH or RH connector and ground with oscilloscope.

Connector	Terminals (Wire color)		Condition	Signal (Reference value)
	(+)	(-)		
D58 (LH) D78 (RH)	19 (G)	Ground	Opening	<p>OCC3383D</p>

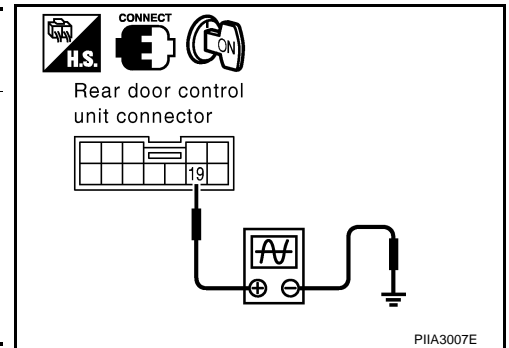

OK or NG

- OK >> Encoder function is OK.  
 NG >> GO TO 5

## 5. CHECK ENCODER CIRCUIT

1. Turn ignition switch OFF.
2. Disconnect rear door control unit LH or RH and rear power window motor LH or RH connector.
3. Check continuity between rear door control unit LH or RH connector D58(LH) or D78(RH) terminal 19 and rear power window motor LH or RH connector D57(LH) or D77(RH) terminal 5.

**19 (G) – 5 (G) :Continuity should exist.**

OK or NG

- OK >> Replace rear power window motor LH or RH.  
 NG >> Repair or replace harness between rear door control unit LH or RH and rear power window motor LH or RH.

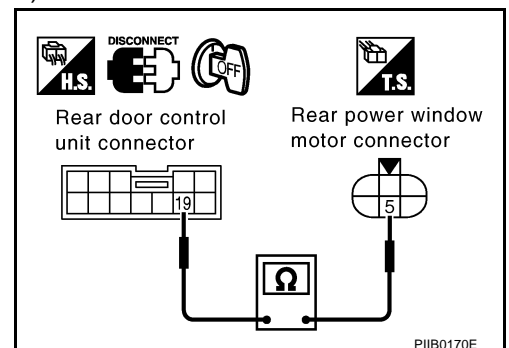

# POWER WINDOW SYSTEM

EIS003PY

## Driver Door Control Unit Circuit Check

### 1. POWER SUPPLY CIRCUIT CHECK

1. Turn ignition switch OFF.
2. Disconnect driver door control unit (LCU01) connector.
3. Check voltage between driver door control unit (LCU01) connector D8 terminal 14 and ground.

**14 (Y/G) – Ground :Battery voltage**

OK or NG

OK >> GO TO 2.

NG >> Check the following.

- 40A fusible link (letter H . located in the fuse and fusible link box).
- Harness for open or short between driver door control unit (LCU01) and fuse.

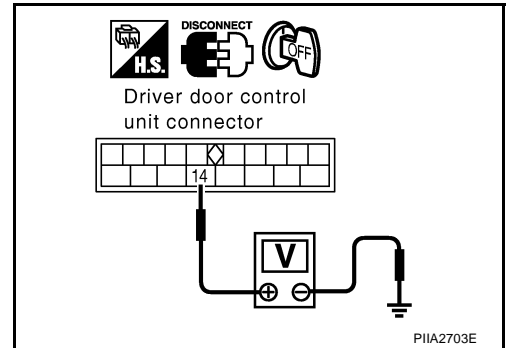

### 2. GROUND CIRCUIT CHECK

Check continuity between driver door control unit (LCU01) connector D8 terminal 15 and ground.

**15 (B) – Ground :Continuity should exist.**

OK or NG

OK >> INSPECTION END.

NG >> Repair or replace harness.

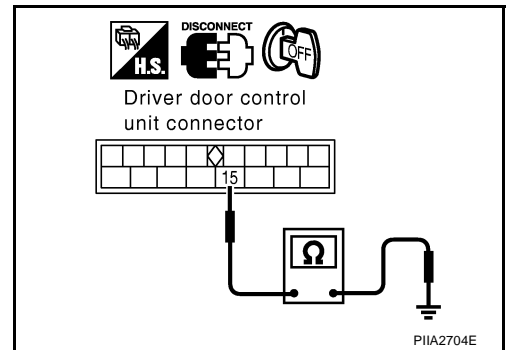

## Passenger Door Control Unit Circuit Check

EIS003PZ

### 1. POWER SUPPLY CIRCUIT CHECK

1. Turn ignition switch OFF.
2. Disconnect passenger door control unit connector.
3. Check voltage between passenger door control unit connector D39 terminal 6 and ground.

**6 (W/R) – Ground :Battery voltage**

OK or NG

OK >> GO TO 2.

NG >> Check the following.

- 40A fusible link (letter H. located in fuse and fusible link box).
- Harness for open or short between passenger door control unit and fuse.

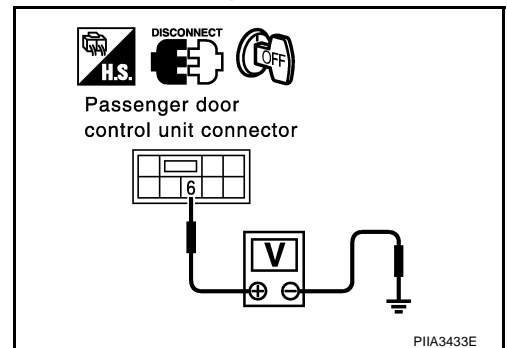

# POWER WINDOW SYSTEM

## 2. GROUND CIRCUIT CHECK

Check continuity between passenger door control unit connector D39 terminal 7 and ground.

**7 (B) – Ground :Continuity should exist.**

OK or NG

OK >> GO TO 3.

NG >> Repair or replace harness.

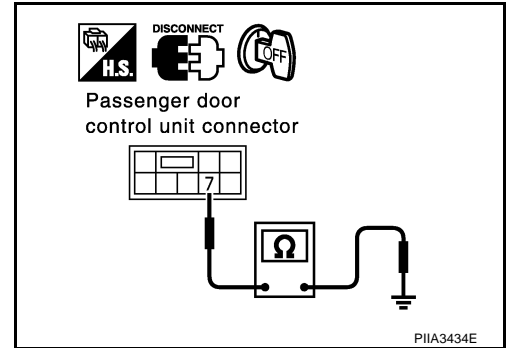

## 3. COMMUNICATION CIRCUIT CHECK

1. Disconnect driver door control unit connector.
2. Check continuity between driver door control unit connector D8 terminal 5 and passenger door control unit connector D38 terminal 11.

**5 (G/OR) – 11 (G/OR) :Continuity should exist.**

OK or NG

OK >> INSPECTION END.

NG >> Repair or replace harness between door control unit and passenger door control unit.

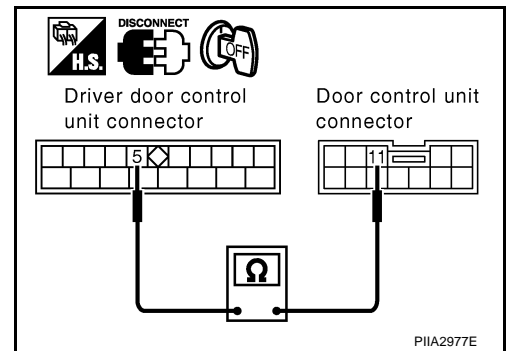

## Rear Door Control Unit Circuit Check

### 1. POWER SUPPLY CIRCUIT CHECK

1. Turn ignition switch OFF.
2. Disconnect rear door control unit LH or RH connector.
3. Check voltage between rear door control unit LH or RH connector D59(LH) or D79(RH) terminal 6 and ground.

**6 (W/R) – Ground :Battery voltage**

OK or NG

OK >> GO TO 2.

NG >> Check the following.

- 40A fusible link (letter H. located in fuse and fusible link box).
- Harness for open or short between rear door control unit LH or RH and fuse.

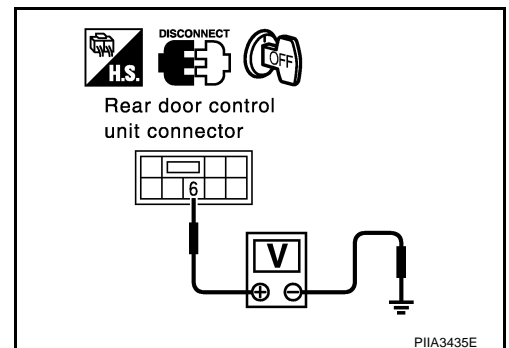

# POWER WINDOW SYSTEM

## 2. GROUND CIRCUIT CHECK

Check continuity between passenger door control unit LH or RH connector D59(LH) or D79(RH) terminal 7 and ground.

**7 (B) – Ground :Continuity should exist.**

OK or NG

- OK >> GO TO 3.
- NG >> Repair or replace harness.

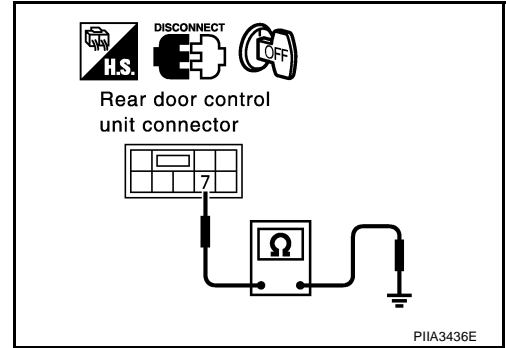

## 3. COMMUNICATION CIRCUIT CHECK

1. Disconnect driver door control unit connector.
2. Check continuity between driver door control unit connector D8 terminal 5 and rear door control unit LH or RH connector D58 (LH), D78 (RH) terminal 11.

**5 (G/OR) – 11 (G/OR) :Continuity should exist.**

OK or NG

- OK >> INSPECTION END.
- NG >> Repair or replace harness between door control unit and rear door control unit LH or RH.

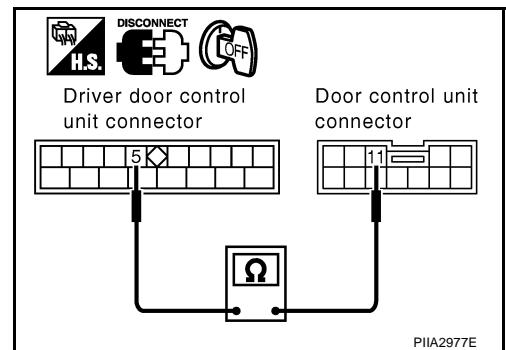

## Door Switch Check

### 1. CHECK DOOR SWITCH INPUT SIGNAL

Ⓜ With CONSULT-II

- Check door switch in "DATE MONITOR" mode with CONSULT-II. Refer to [RF-15](#)

**When door is opened : DOOR SW ON**

**When door is closed : DOOR SW OFF**

ⓧ Without CONSULT-II

- Check all door switches in switch monitor mode. Refer to Remote keyless entry system [BL-81, "SWITCH MONITOR"](#).

OK or NG

- OK >> Door switch is OK.
- NG >> GO TO 2

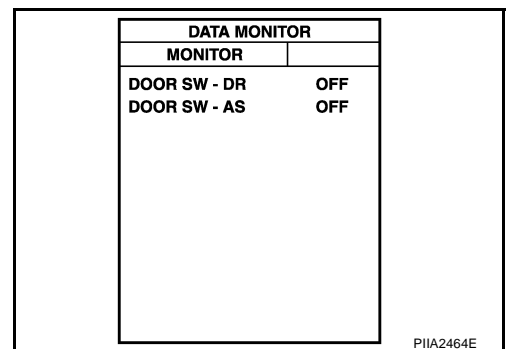

# POWER WINDOW SYSTEM

## 2. CHECK DOOR SWITCH

1. Turn ignition switch OFF.
2. Disconnect door switch connector.
3. Check continuity between following terminals and ground.

Door switch connector		Terminals (Wire color)		Condition	Continuity
Front door switch (driver side)	B20	1 (W/R)	Ground	Pressed	No
				Repressed	Yes
Front door switch (passenger side)	B220			Pressed	No
				Repressed	Yes

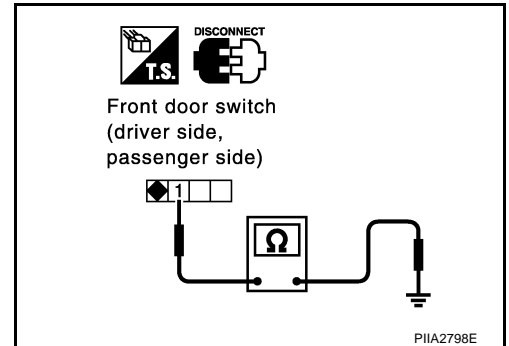

### OK or NG

- OK >> Repair or replace following item, when there is a malfunction.
- Door switch ground condition
  - Harness for open or short between door switch and BCM
- NG >> Replace door switch.

A  
B  
C  
D  
E  
F  
G  
H  
J  
K  
L  
M

GW

# POWER WINDOW SYSTEM

## Rear Power Window Switch Illumination SCHEMATIC — SW/ILL —

EIS0012P

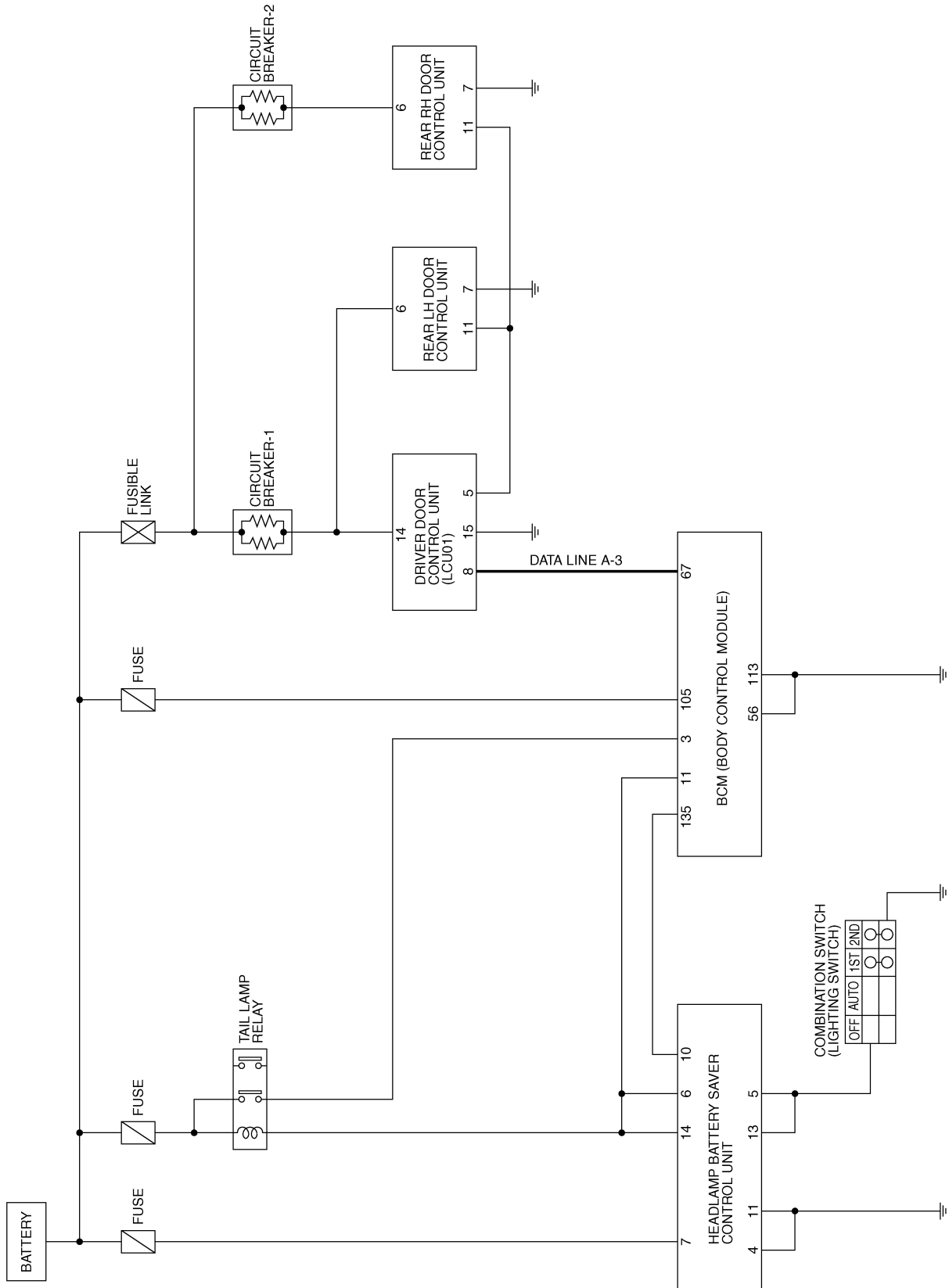

TIWM0048E

# POWER WINDOW SYSTEM

## WIRING DIAGRAM — SW/ILL —

GW-SW/ILL-01

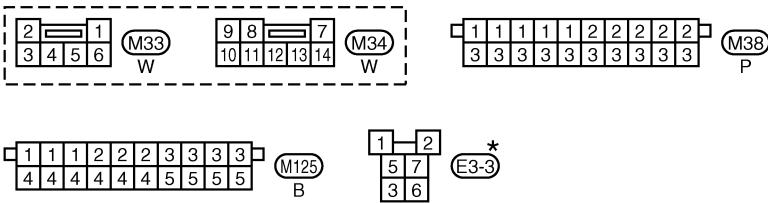
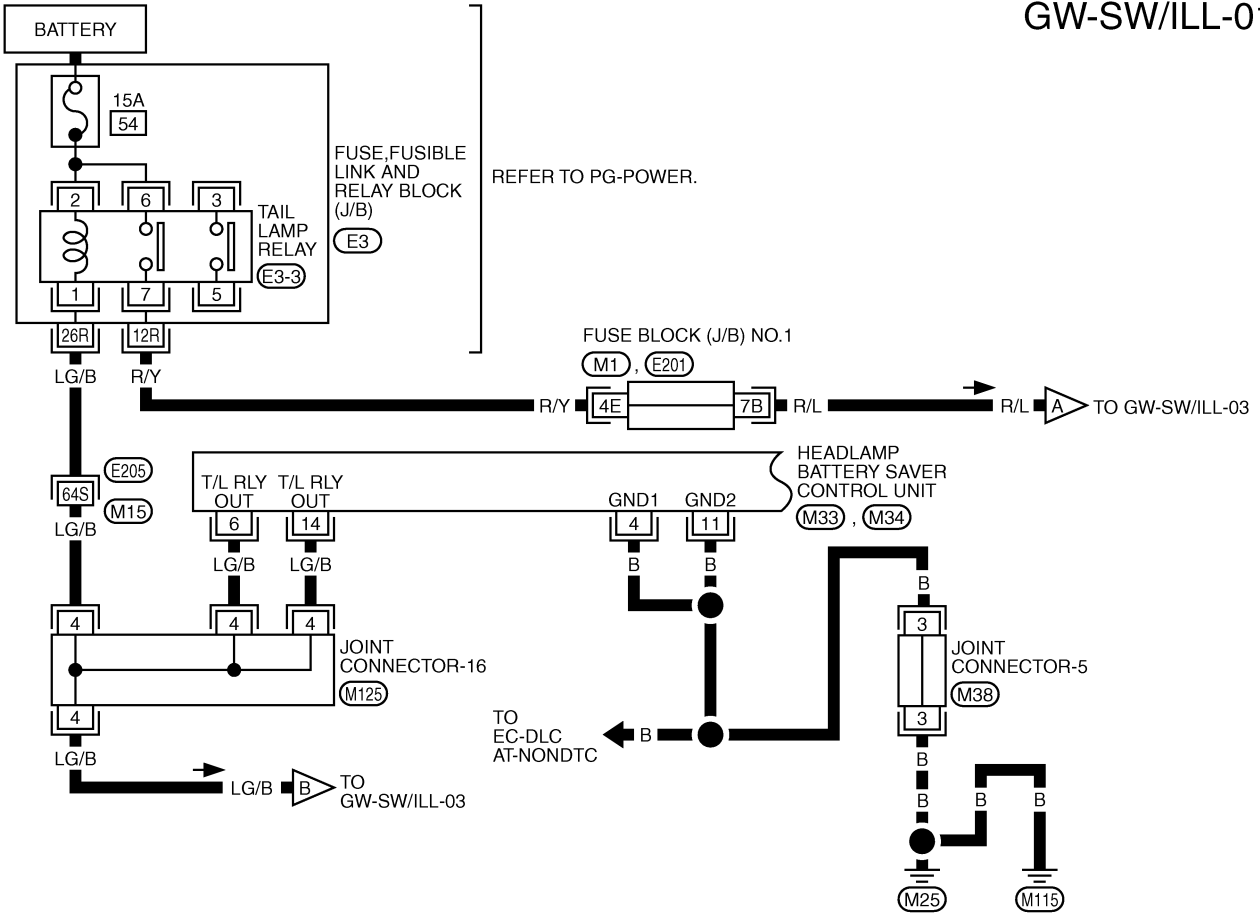

\*: THIS CONNECTOR IS NOT SHOWN IN "HARNESS LAYOUT", PG SECTION.

REFER TO THE FOLLOWING.

- (E205) -SUPER MULTIPLE JUNCTION (SMJ)
- (M1), (E201) -FUSE BLOCK-JUNCTION BOX (J/B) NO.1
- (E3) -FUSE, FUSIBLE LINK AND RELAY BLOCK (J/B)

TWWM0214E

# POWER WINDOW SYSTEM

GW-SW/ILL-02

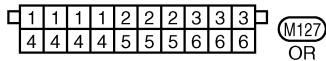
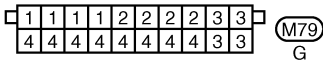
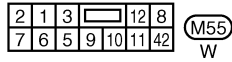
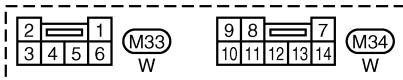
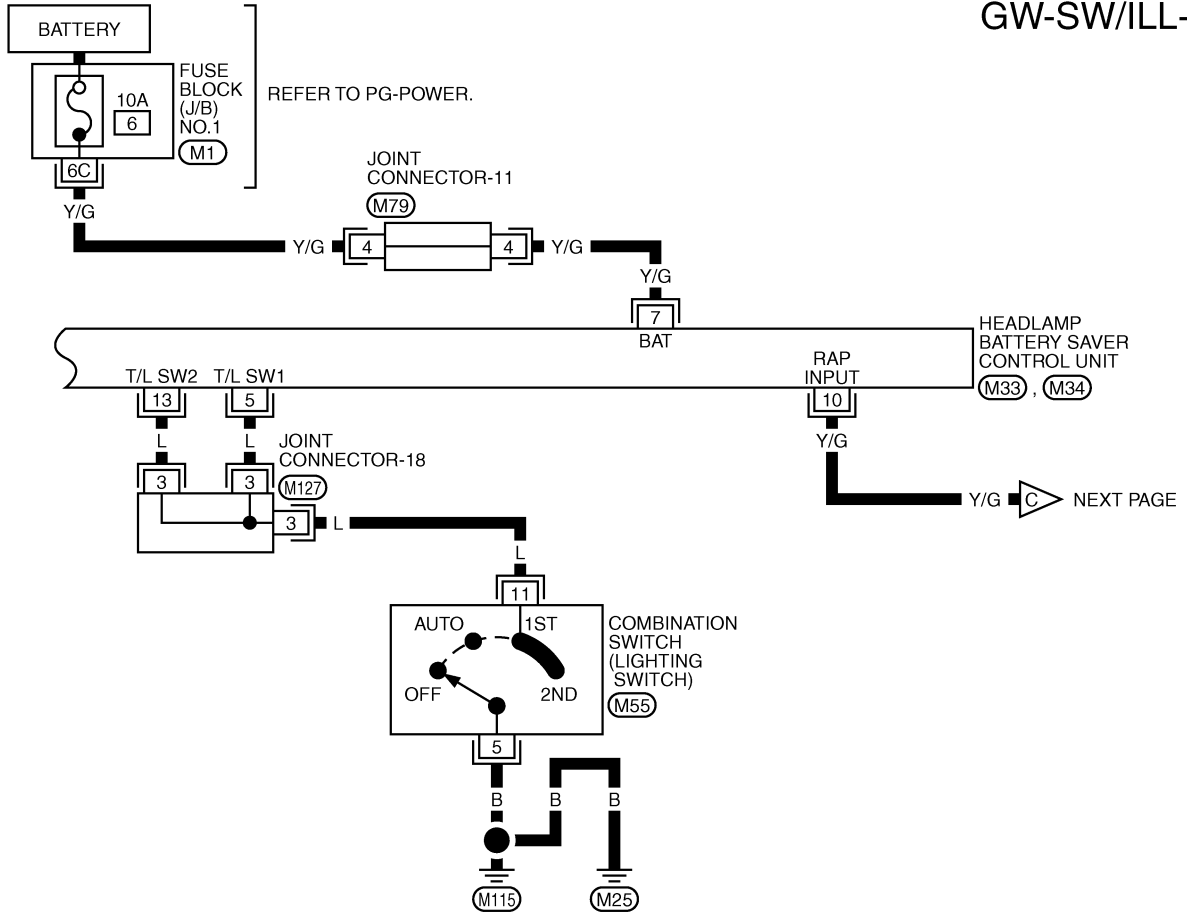

REFER TO THE FOLLOWING.

(M1) -FUSE BLOCK-JUNCTION BOX (J/B) NO.1

TIWM0050E



# POWER WINDOW SYSTEM

GW-SW/ILL-03

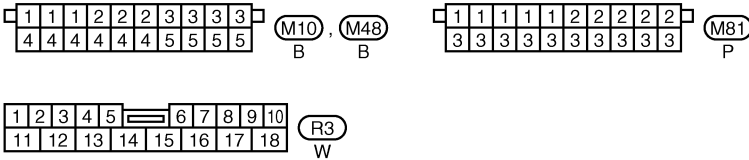
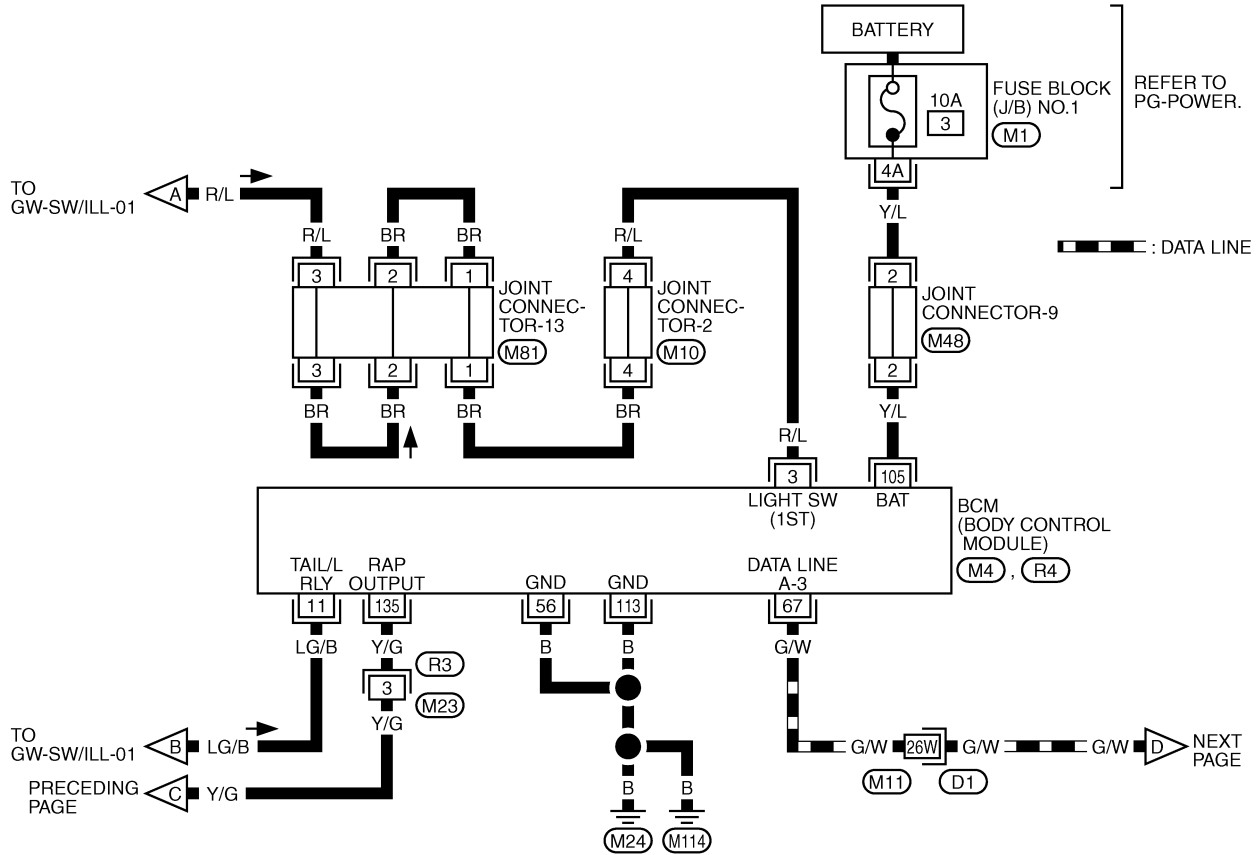

REFER TO THE FOLLOWING.

- (D1) -SUPER MULTIPLE JUNCTION (SMJ)
- (M1) -FUSE BLOCK-JUNCTION BOX (J/B) NO.1
- (M4), (R4) -ELECTRICAL UNITS

TIWM0215E

# POWER WINDOW SYSTEM

GW-SW/ILL-04

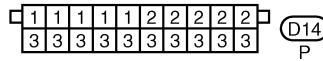
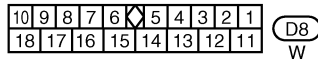
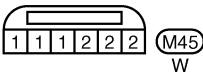
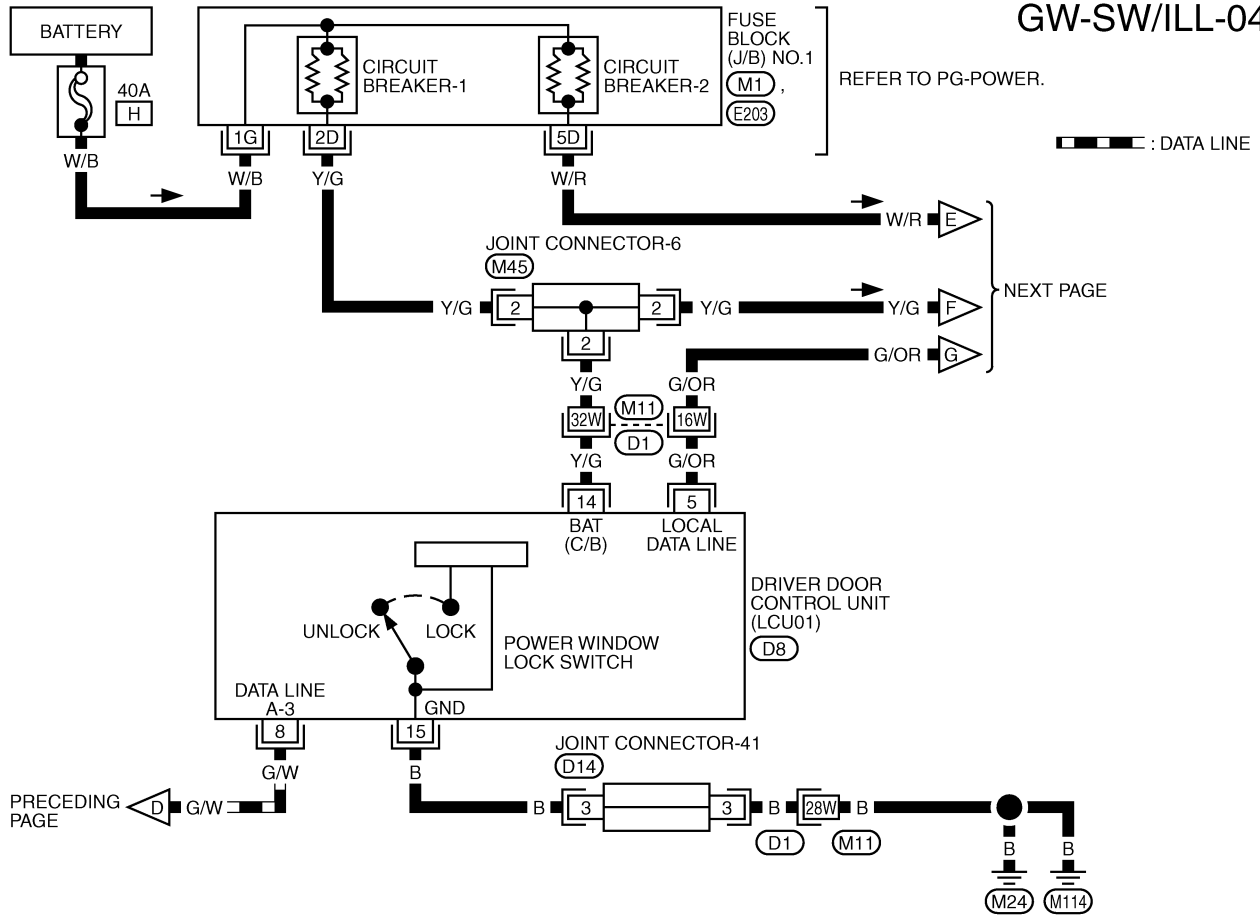

REFER TO THE FOLLOWING.  
 (D1) -SUPER MULTIPLE JUNCTION (SMJ)  
 (M1), (E203) -FUSE BLOCK-JUNCTION BOX (J/B) NO.1

TIWM0216E

# POWER WINDOW SYSTEM

GW-SW/ILL-05

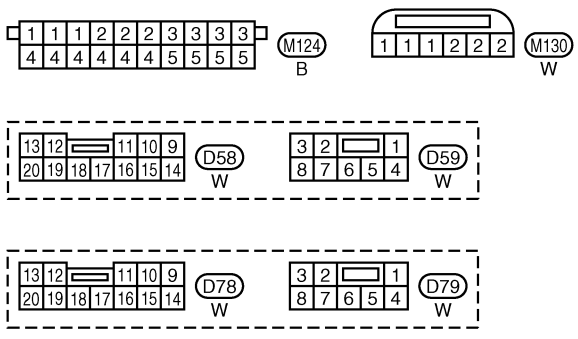
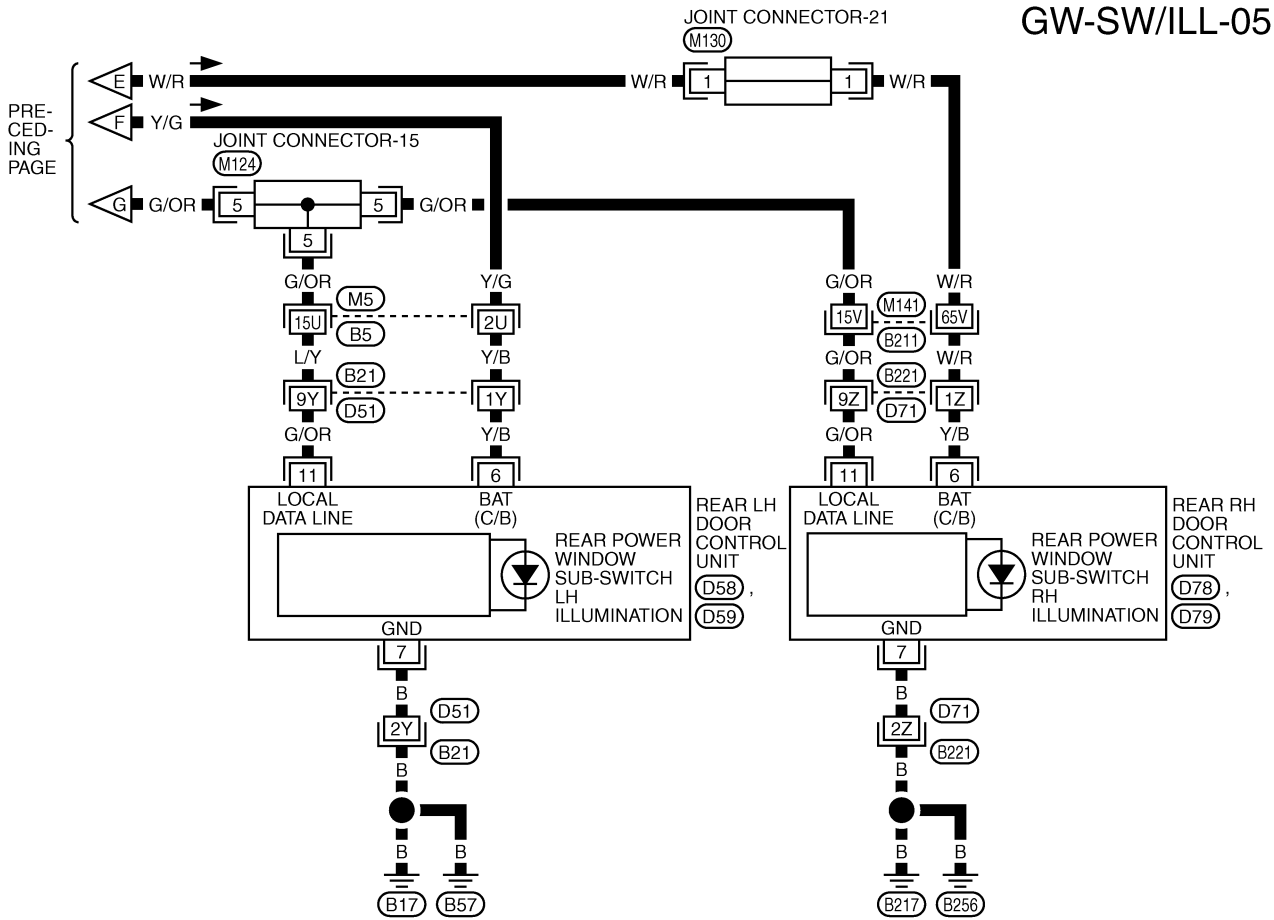

REFER TO THE FOLLOWING.  
 (M5), (B21), (B211), (B221)  
 -SUPER MULTIPLE JUNCTION (SMJ)

# FRONT DOOR GLASS AND REGULATOR

## FRONT DOOR GLASS AND REGULATOR

PF:80300

### Removal and Installation

E/S009LX

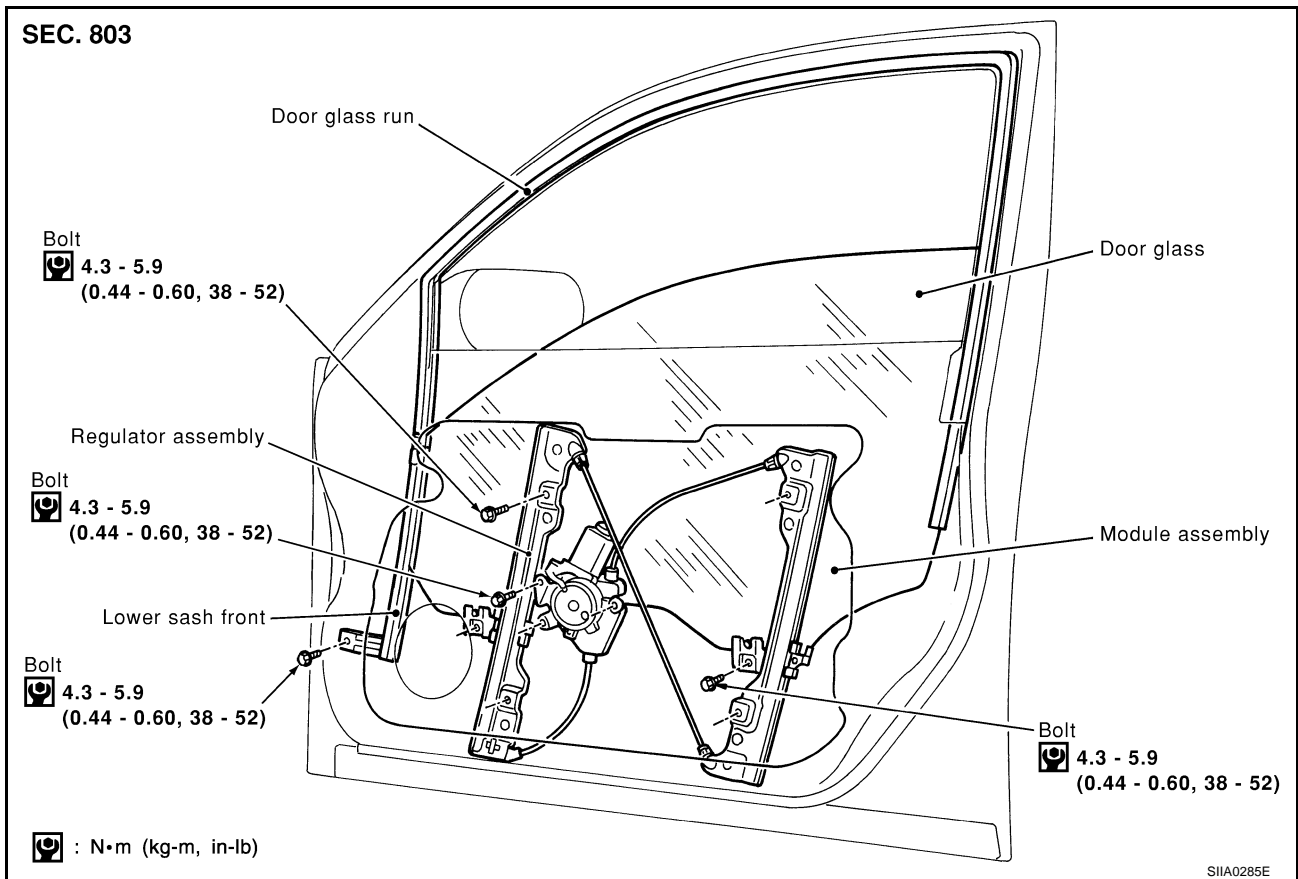

### REMOVAL

1. Remove the front door finisher and the front door sash cover. Refer to [EI-31, "DOOR FINISHER"](#).
2. Remove the door speaker. Refer to [AV-40, "Removal and Installation of Door Speaker"](#).
3. Pull the inside seal out of the inner panel.

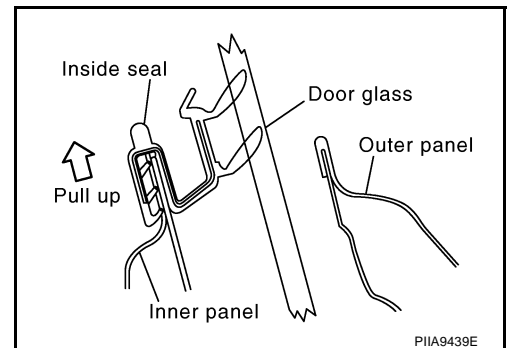

4. Operate the power window main switch to raise/lower the door window until the glass mounting bolts can be seen.
5. Remove the glass mounting bolts.

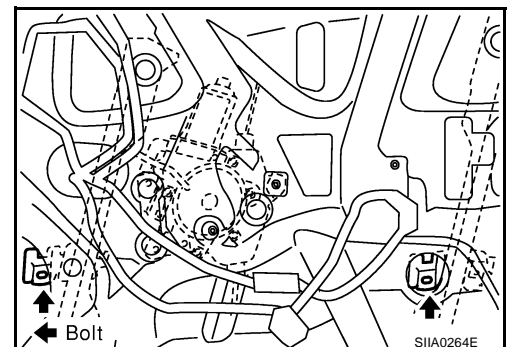

# FRONT DOOR GLASS AND REGULATOR

6. While holding the door glass, raise it at the rear end to pull the glass out of the sash toward the outside of the door.

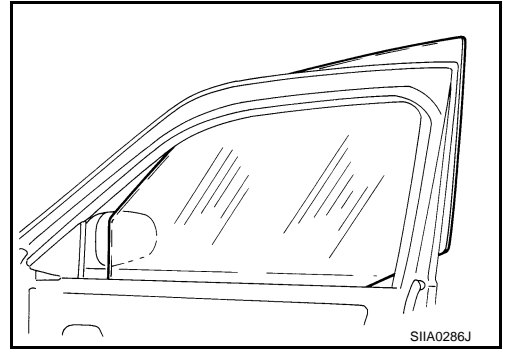

7. Remove the mounting bolts, and remove the module assembly.
8. Disconnect the harness connector for the module assembly, and remove the harness clip from the back.

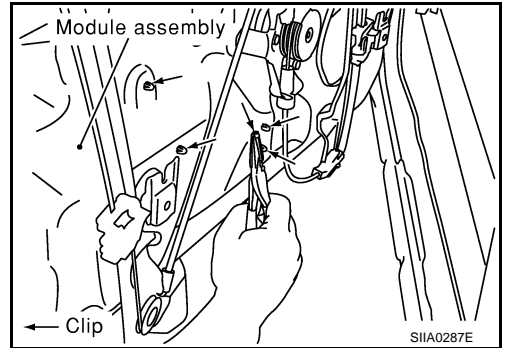

## INSTALLATION

Install in the reverse order of removal.

## INSPECTION AFTER REMOVAL

Check the regulator assembly for the following items. If a malfunction is detected, replace or grease it.

- Wire wear
- Regulator deformation
- Grease condition for each sliding part

The arrows in the figure show the application points of the multi-purpose grease.

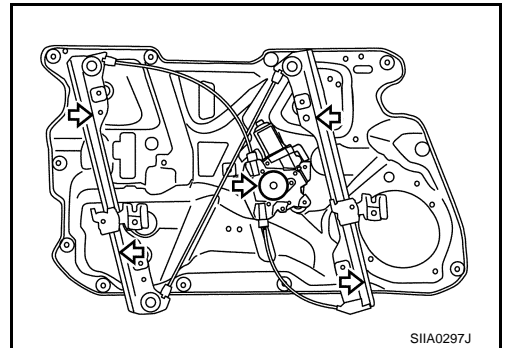

## DISASSEMBLY

Remove the power window motor and guide rail from the module assembly.

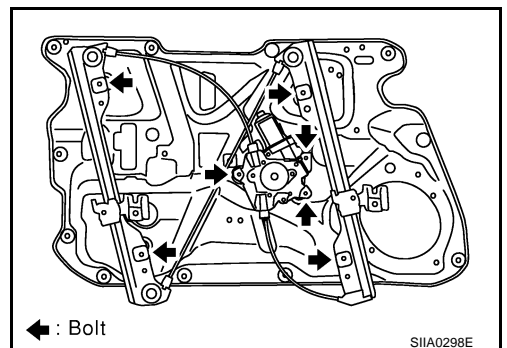

## ASSEMBLY

Assemble in the reverse order of disassembly.

A  
B  
C  
D  
E  
F  
G  
H

GW

J  
K  
L  
M

# FRONT DOOR GLASS AND REGULATOR

## SETTING AFTER INSTALLATION

### Setting of Limit Switch

If any of the following work has been done, set the limit switch (integrated in the motor).

- Removal and installation of the regulator.
- Removal and installation of the motor from the regulator.
- Operate the regulators as a unit.
- Removal and installation of the glass.
- Removal and installation of the glass run.

### Resetting

After installing each component to the vehicle, follow the steps below.

1. Raise the glass to the top position.
2. While pressing and holding the reset switch, lower the glass to the bottom position.
3. Release the reset switch, and check that the reset switch returns to the original position, and then raise the glass to the top position.

### **CAUTION:**

**Do not operate the glass automatically to raise the glass to the top position.**

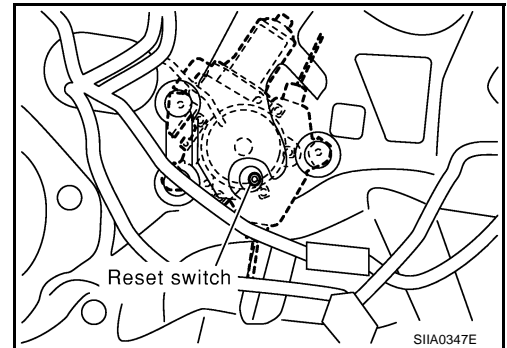

## FITTING INSPECTION

- Check that the glass is securely fit into the glass run groove.
- Lower the glass slightly [approx. 10 to 20 mm (0.39 to 0.79 in)] and check that the clearance to the sash is parallel. If the clearance between the glass and sash is not parallel, loosen the regulator mounting bolts, guide rail mounting bolts, and glass & guide rail mounting bolts to correct the glass position.

# REAR DOOR GLASS AND REGULATOR

## REAR DOOR GLASS AND REGULATOR

PFP:82300

### Removal and Installation

EIS009LY

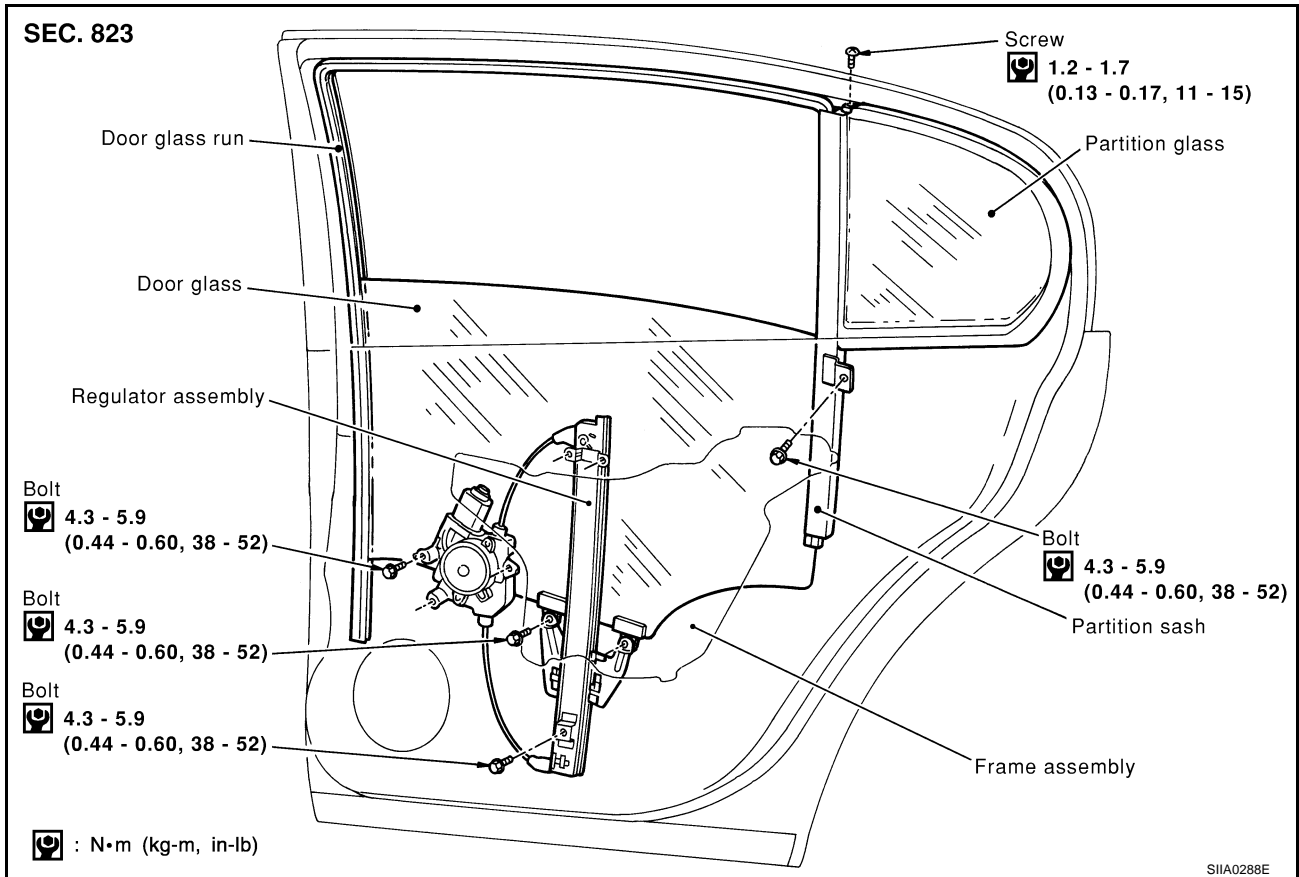

### REMOVAL

1. Lower the glass to the bottom position.
2. Remove the rear door outside molding. Refer to [EI-28, "DOOR OUTSIDE MOLDING"](#).
3. Remove the rear door finisher. Refer to [EI-31, "DOOR FINISHER"](#).
4. Pull the inside seal out of the inner panel.

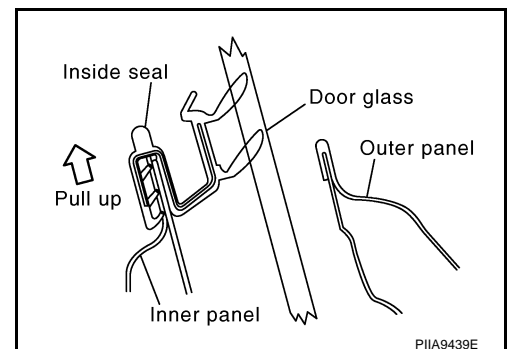

5. Remove the mounting bolts, and remove the frame assembly.

A  
B  
C  
D  
E  
F  
G  
H  
GW  
J  
K  
L  
M

## REAR DOOR GLASS AND REGULATOR

6. Remove the harness connector routed on the frame assembly, then remove the harness clip from the back.

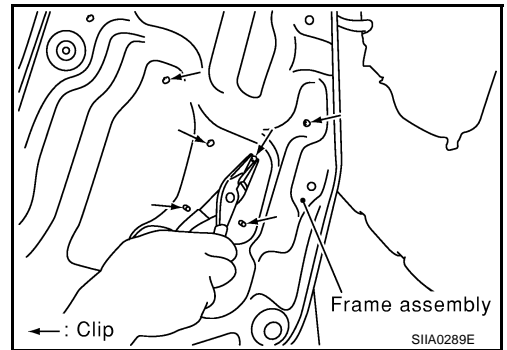

7. Remove the glass run from the partition sash.  
8. Remove the partition sash mounting bolts (lower) and screw (upper) to remove the sash.

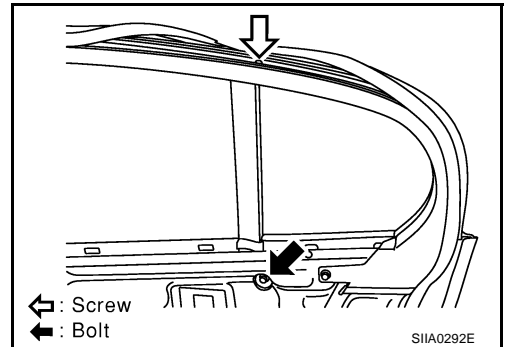

9. Operate the power window switch to raise/lower the door window until the glass mounting bolts can be seen.  
10. Remove the glass mounting bolts, and remove the glass from the inside of the panel.

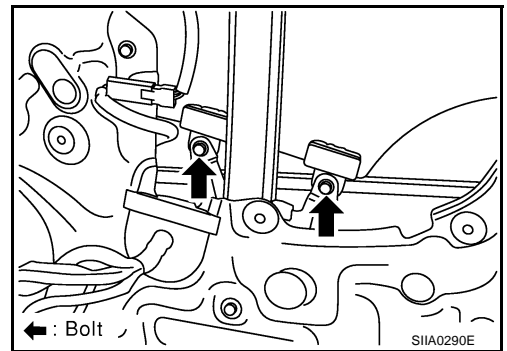

11. Remove the mounting bolts, and remove the regulator and guide channel from the panel.  
12. Disconnect the connector for the regulator assembly.

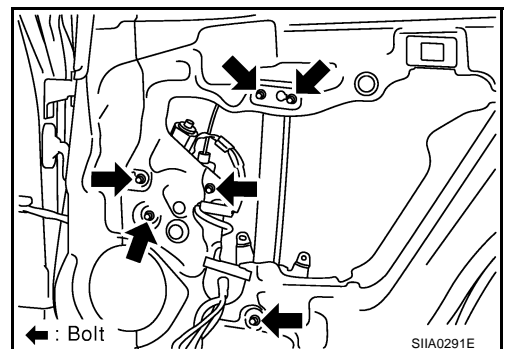

13. Remove the partition glass from the panel.

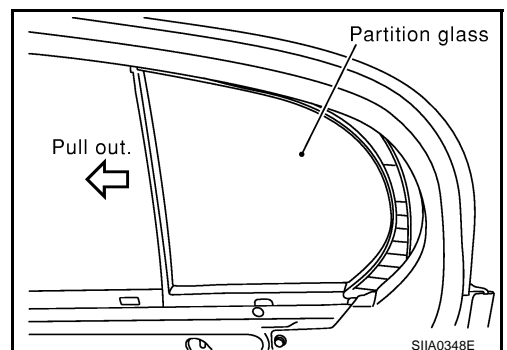



# REAR DOOR GLASS AND REGULATOR

## INSTALLATION

Install in the reverse order of removal.

## INSPECTION AFTER REMOVAL

Check the regulator assembly for the following items. If a malfunction is detected, replace or grease it.

- Wire wear
- Regulator deformation
- Grease condition for each sliding part

The arrows in the figure show the application points of the body grease.

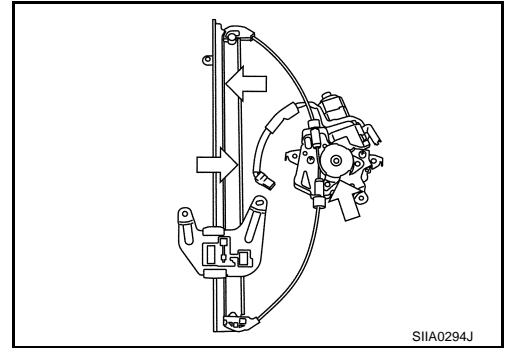

## SETTING AFTER INSTALLATION

If any of the following work has been done, set the limit switch (integrated in the motor).

- Removal and installation of the regulator.
- Removal and installation of the motor from the regulator.
- Operate the regulators a unit.
- Removal and installation of the glass.
- Removal and installation of the glass run.

### Setting of Limit Switch

After installing each component to the vehicle, follow the steps below.

#### **CAUTION:**

**Do not install the frame assembly.**

1. Raise the glass to the top position.
2. While pressing and holding the reset switch, lower the glass to the bottom position.
3. Release the reset switch, and check that the reset switch returns to the original position, and then raise the glass to the top position.

#### **CAUTION:**

**Do not operate the glass automatically to raise the glass to the top position.**

## FITTING INSPECTION

- Check that the glass is securely fit into the glass run groove.
- Lower the glass slightly [approx. 10 to 20 mm (0.39 to 0.79 in)], and check that the clearance to the sash is parallel. If the clearance between the glass and sash is not parallel, loosen the regulator mounting bolts, the guide rail mounting bolts, and the glass and carrier plate mounting bolts to correct the glass position.

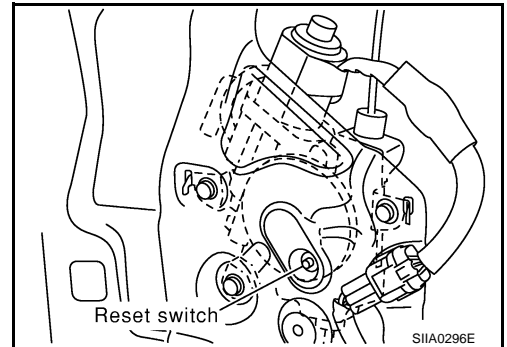

A

B

C

D

E

F

G

H

GW

J

K

L

M





# REAR WINDOW DEFOGGER

PFP:25350

## REAR WINDOW DEFOGGER

### Component Parts and Harness Connector Location

EIS008FT

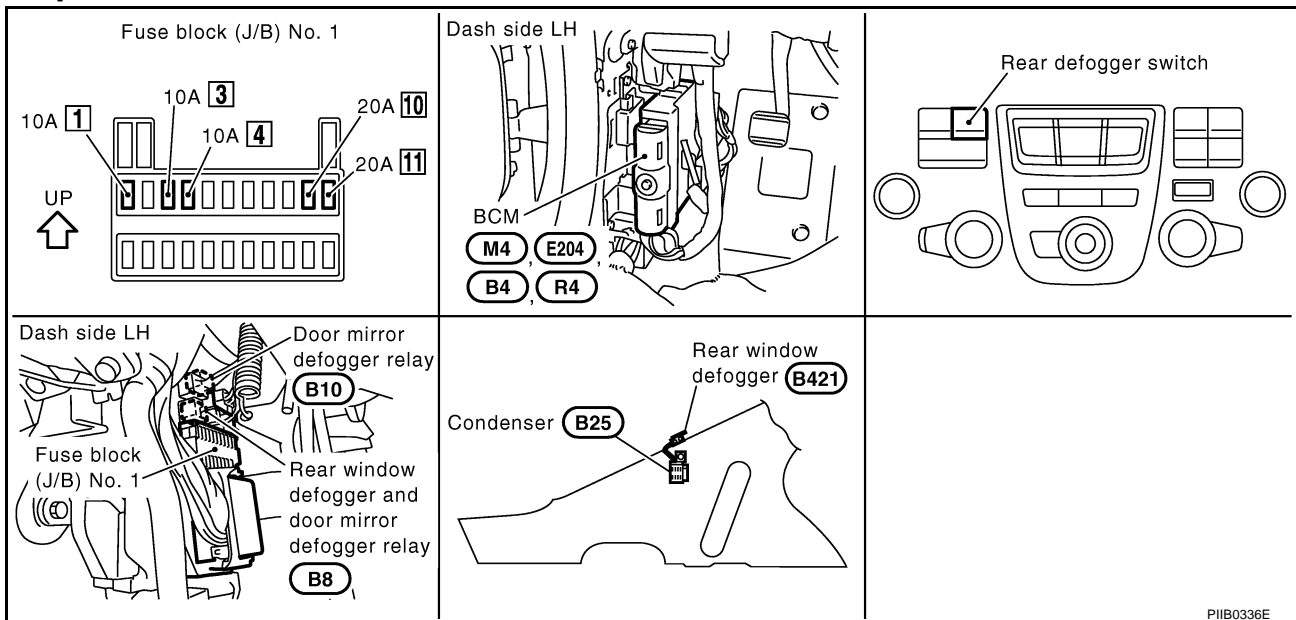

### System Description

EIS008FU

The rear window defogger system is controlled by the BCM (Body Control Module). The rear window defogger is operated only for approximately 15 minutes.

Power is supplied at all times

- through 20A fuse[NO.10, located in the fuse block (J/B)]
- to the rear window defogger and door mirror defogger relay terminal 6,
- through 20A fuse[NO.11, located in the fuse block (J/B)]
- to the rear window defogger and door mirror defogger relay terminal 3,
- through 10A fuse[NO.3, located in the fuse block (J/B)]
- to BCM terminal 105,

With the ignition switch in the ACC or ON position, power is supplied

- through 10A fuse[NO.4, located in the fuse block (J/B)]
- to the door mirror defogger relay terminal 5,

With the ignition switch in the ON or START position, power is supplied

- through 10A fuse[NO.1, located in the fuse block (J/B)]
- to BCM terminal 68,
- to the rear window defogger and door mirror defogger relay terminal 1,

When the rear defogger switch in the multifunction switch is ON, ground is supplied

- through terminal 5 from the multifunction switch (rear window defogger switch),
- to BCM terminal 10.

Then ground is supplied

- through BCM terminal 56 and 113
- through body grounds M24 and M114.

Then BCM recognizes that rear window defogger switch is turned to ON.

When BCM recognized that rear window defogger switch is turned to ON, ground is supplied

- to the rear window defogger and door mirror defogger relay terminal 2,
- through BCM terminal 144,

## REAR WINDOW DEFOGGER

- through BCM terminal 56 and 113
- through body grounds M24 and M114, and rear window defogger relay and door mirror defogger is energized.

When rear window defogger and door mirror defogger relay is turned ON, power is supplied

- to rear window defogger terminal 2,
- through condenser terminal 1,
- through rear window defogger and door mirror defogger relay terminal 5 and 7.

Rear window defogger terminal 1 is ground through body ground B422.

With power and ground supplied rear window defogger filaments heat and defog the rear window.

When rear window defogger and door mirror defogger relay is turned ON, power is supplied.

- to door mirror defogger relay terminal 2,
- through rear window defogger and door mirror defogger relay terminal 5 and 7.

Door mirror defogger relay terminal 1 is ground through body ground B17 and B57.

With power and ground supplied,

Door mirror defogger relay is energized.

When door mirror defogger relay is turned ON, power is supplied.

- to door mirror defogger terminal (Driver side and Passenger side) 6.
- through door mirror defogger relay terminal 3.

Door mirror defogger (Driver side and Passenger side) terminal 5 is ground through body grounds M24 and M114.

With power and grounds supplied, door mirror defogger filaments heat and defog the mirror.

When rear window defogger and door mirror defogger relay is turned ON, power is supplied.

- to multifunction switch (rear window defogger switch) terminal 6,
- through rear window defogger and door mirror defogger relay terminal 5 and 7.

Multifunction switch (rear window defogger switch) terminal 2 is ground through body ground M24 and M114. And then energizes rear window defogger indicator is illuminated.

A

B

C

D

E

F

G

H

GW

J

K

L

M

# REAR WINDOW DEFOGGER

## Schematic

EIS008FV

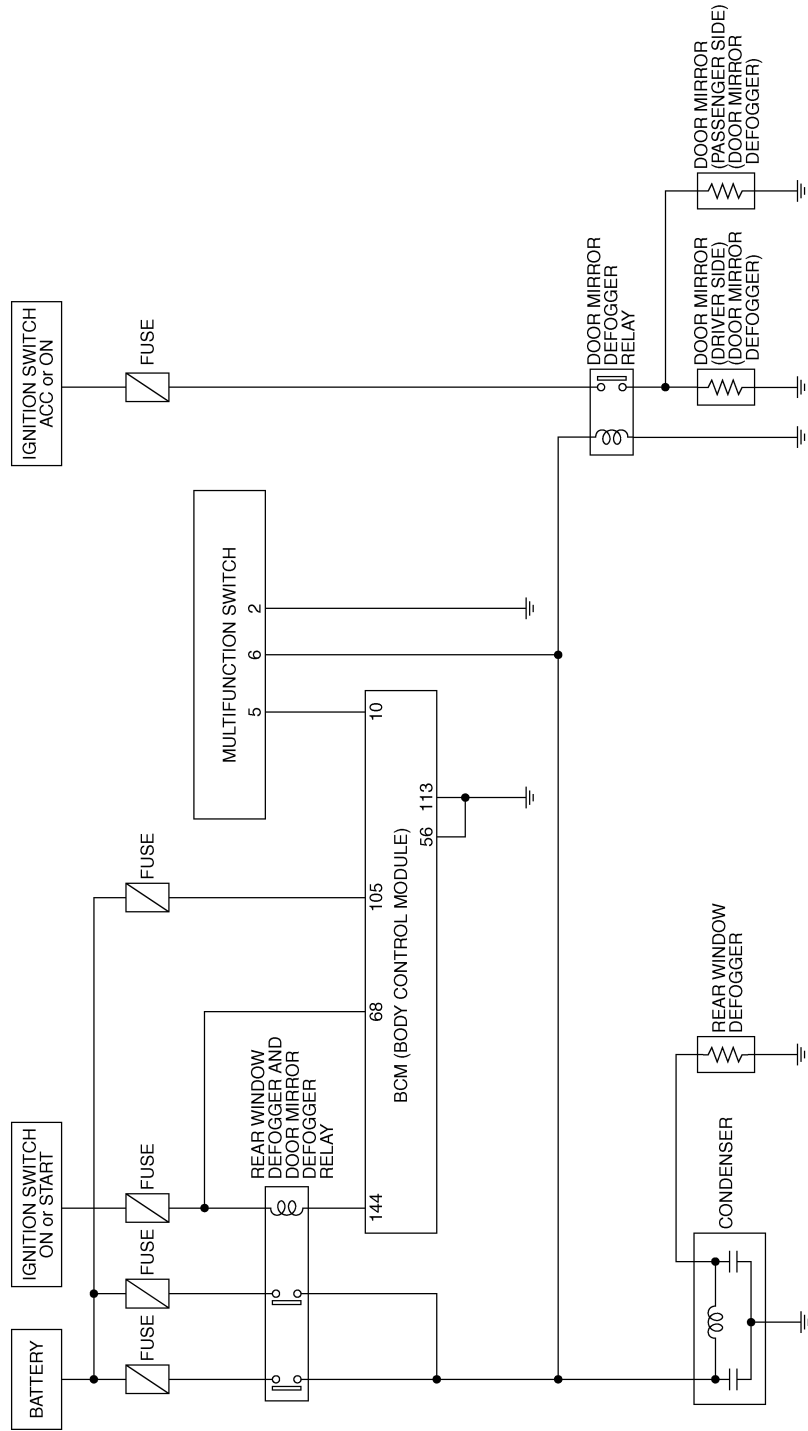







# REAR WINDOW DEFOGGER

GW-DEF-03

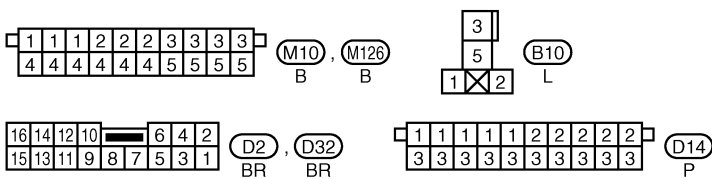
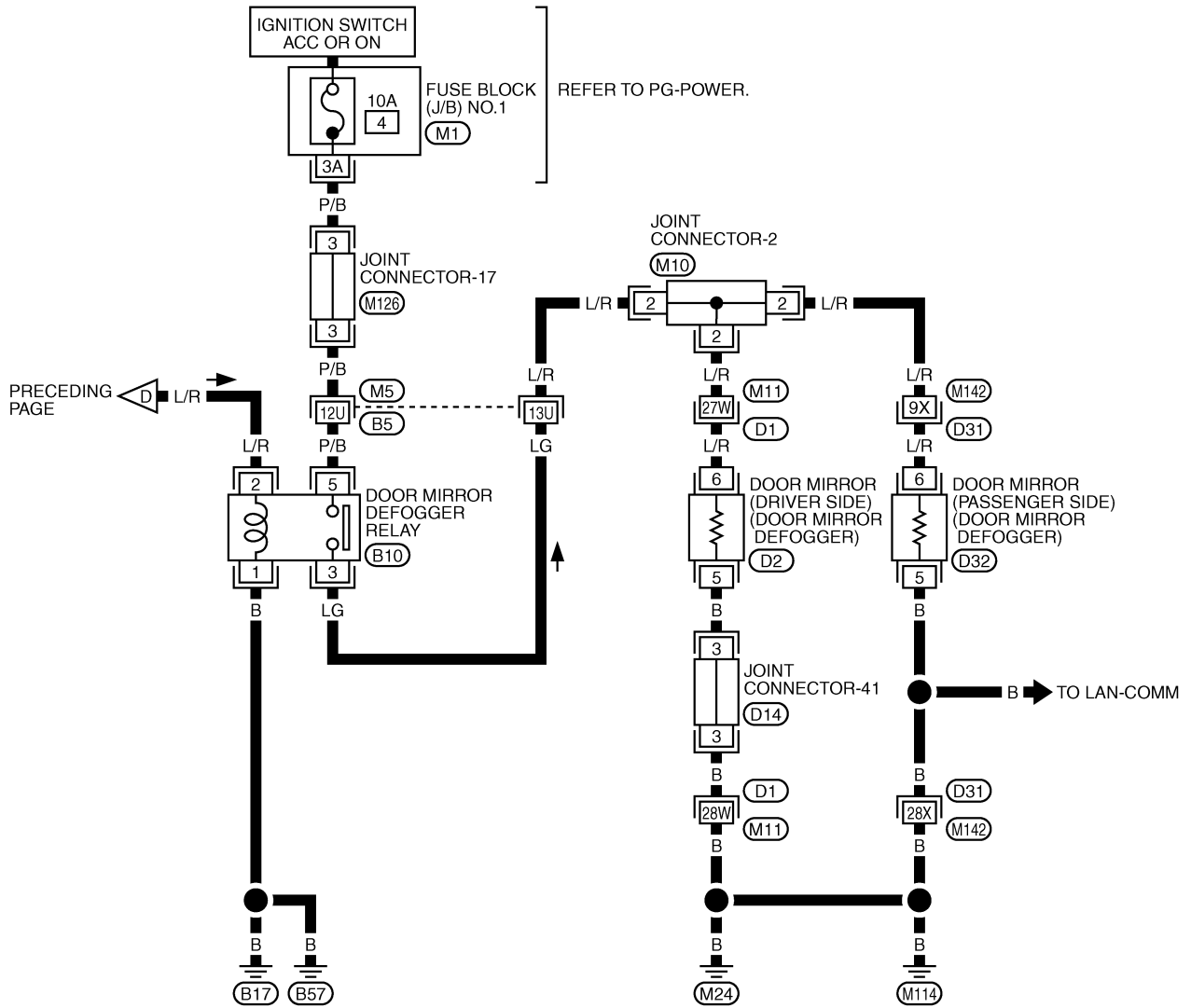

REFER TO THE FOLLOWING.  
 (M5), (D1), (D31) -SUPER  
 MULTIPLE JUNCTION (SMJ)  
 (M1) -FUSE BLOCK-JUNCTION  
 BOX (J/B) NO.1

TIWM0179E

# REAR WINDOW DEFOGGER

## Terminals and reference value for BCM

EIS008FX

TERMINAL	WIRE COLOR	ITEM	CONDITION	VOLTAGE [V] (Approx.)
10	G/R	Rear defogger switch signal	Rear defogger switch ON (With the switch pressed)	0
			Rear defogger switch OFF	5
56	B	Ground	–	0
68	W/B	Ignition switch (ON)	Ignition switch (ON or START position)	Battery voltage
105	Y/L	Power source (Fuse)	–	Battery voltage
113	B	Ground	–	0
144	G/W	Rear window defogger and door mirror defogger relay control signal	Rear defogger switch ON	0
			Rear defogger switch OFF	Battery voltage

## Work Flow

EIS008FY

1. Check the symptom and customer's requests.
2. Understand the outline of system. Refer to [GW-60, "System Description"](#).
3. The preliminary check. Refer to [GW-66, "Preliminary Check"](#).
4. According to the trouble diagnosis chart, repair or replace the cause of the malfunction. Refer to [GW-69, "Trouble Diagnoses Symptom Chart"](#).
5. Does rear defogger operate normally?  
OK: GO TO 6.  
NG: GO TO 4.
6. Inspection end.

## Preliminary Check

EIS008FZ

### POWER SUPPLY AND GROUND CIRCUIT INSPECTION

#### 1. FUSE INSPECTION

- Check that any of the following fuses in the BCM is blown.

Unit	Terminal NO.	Power source	Fuse NO.
BCM	105	BAT power supply	#3
	68	IGN power supply	#1

#### NOTE:

Refer to [GW-60, "Component Parts and Harness Connector Location"](#).

#### OK or NG

OK >> GO TO 2.

NG >> If fuse is blown, be sure to eliminate cause of problem before installing new fuse. Refer to [PG-2, "POWER SUPPLY ROUTING"](#).

# REAR WINDOW DEFOGGER

## 2. POWER SUPPLY CIRCUIT INSPECTION (BCM)

1. Turn ignition switch OFF.
2. Disconnect the BCM connector M4, check voltage between connector terminal (refer to the Chart below) of the harness connector and ground.

Terminals		Power source	Condition	Voltage [V] (Approx.)
(+)				
Connector	Terminal (Wire color)	(-)		
M4	105(Y/L)	Ground	BAT power supply	Ignition switch OFF
	68(W/B)		IGN power supply	Ignition switch ON

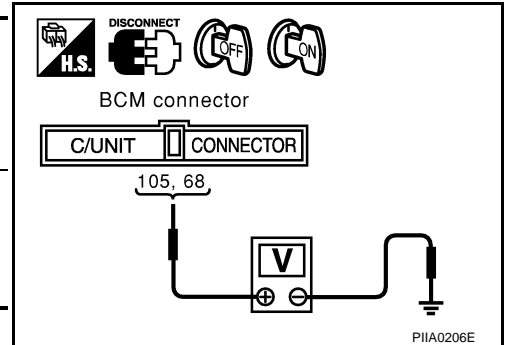

OK or NG

- OK >> GO TO 3.  
 NG >> Check harness for open and short between BCM and fuse.

## 3. GROUND CIRCUIT INSPECTION (BCM)

Check continuity between BCM connector M4 terminals and ground.

- 56 (B) – Ground :Continuity should exist.**  
**113 (B) – Ground :Continuity should exist.**

OK or NG

- OK >> System is OK.  
 NG >> Repair or replace harness.

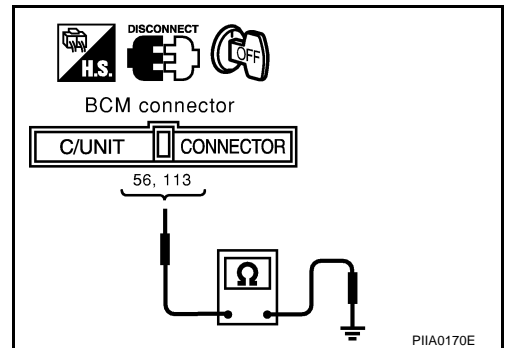

EIS008G0

## CONSULT-II Function CONSULT-II BASIC OPERATION PROCEDURE

1. Turn ignition switch "OFF".
2. Connect "CONSULT-II" and CONSULT-II CONVERTER to data link connector.

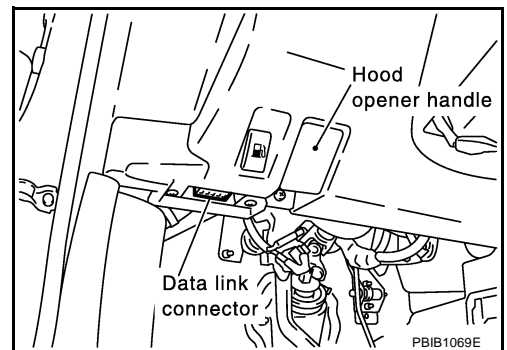

# REAR WINDOW DEFOGGER

3. Turn ignition switch "ON".
4. Touch "START(NISSAN BASED VHCL)".

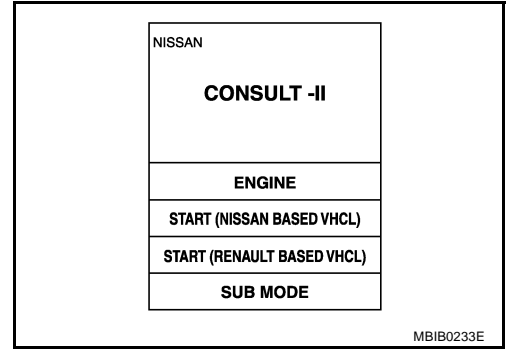

5. Touch "IVMS" on the "SELECT SYSTEM" screen. If "BCM" is not indicated, go to Refer to [GI-38](#) , "CONSULT-II Date Link Connector (DLC) Circuit".

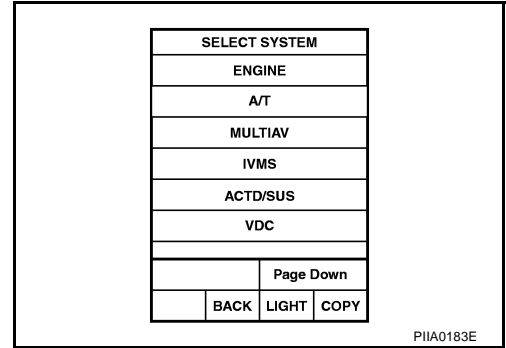

6. Check the model specification, and touch either "WITH SUNROOF" or "WITHOUT SUNROOF" on the "SELECT SYS COND" screen.
7. Touch "OK". If the selection is wrong, touch "CANCEL".
8. Select the desired part to be diagnosed on the "SELECT TEST ITEM" screen.

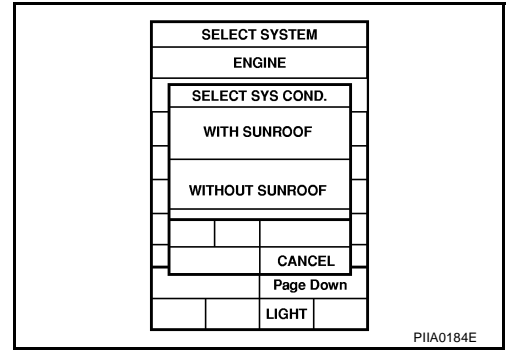

## DATA MONITOR

### Display Item List

Monitor item "Operation"		Content
REAR DEF SW	"ON/OFF"	Displays "Press (ON)/others (OFF)" status determined with the rear window defogger switch.
IGN ON SW	"ON/OFF"	Displays "IGN (ON)/OFF" status determined with the ignition switch signal.

## ACTIVE TEST

### Display Item List

Test item	Content
REAR DEFOGGER	Gives a drive signal to the rear window defogger to activate it.

# REAR WINDOW DEFOGGER

## Trouble Diagnoses Symptom Chart

EIS008G1

- Check that other systems using the signal of the following systems operate normally.

Symptom	Diagnoses / service procedure	Refer to page
Rear window defogger and door mirror defogger do not operate.	1. Rear window defogger switch circuit check.	<a href="#">GW-69</a>
	2. Rear window defogger and door mirror defogger circuit check.	<a href="#">GW-70</a>
Rear window defogger does not operate but door mirror defogger operate.	1. Rear window defogger circuit check.	<a href="#">GW-73</a>
	2. Filament check.	<a href="#">GW-77</a>
Door mirror defogger does not operated, but rear window defogger operates.	1. Door mirror defogger power supply circuit check.	<a href="#">GW-74</a>
Driver side door mirror defogger does not operated, but other defogger operates.	1. Driver side door mirror defogger circuit check.	<a href="#">GW-76</a>
Passenger side door mirror defogger does not operated, but other defogger operates.	1. Passenger side door mirror defogger circuit check.	<a href="#">GW-77</a>

## Rear Window Defogger Switch Circuit Check.

EIS008G2

### 1. CHECK REAR WINDOW DEFOGGER (MULTI-FUNCTION) SWITCH

#### Ⓜ With CONSULT-II

Check rear window defogger switch "REAR DEF SW" in the "DATA MONITOR" mode with CONSULT-II, Refer to [GW-68, "DATA MONITOR"](#) .

**When rear window defogger switch ON**  
**REAR DEF SW :ON**

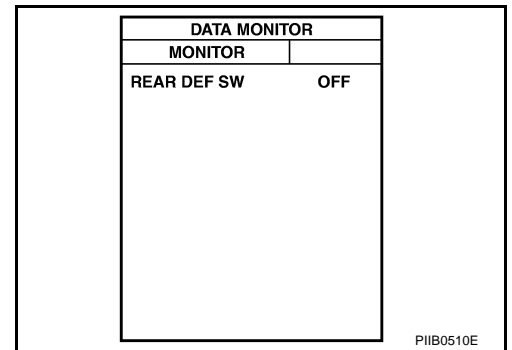

#### ⊗ With out CONSULT-II

1. Turn ignition switch ON.
2. Check voltage between BCM connector and ground.

Connector	Terminal (Wire color)		Condition	Voltage [V] (Approx)
	(+)	(-)		
M4	10 (G/R)	Ground	Rear window defogger switch is ON. (With the switch pressed)	0
			Rear window defogger switch is OFF.	5

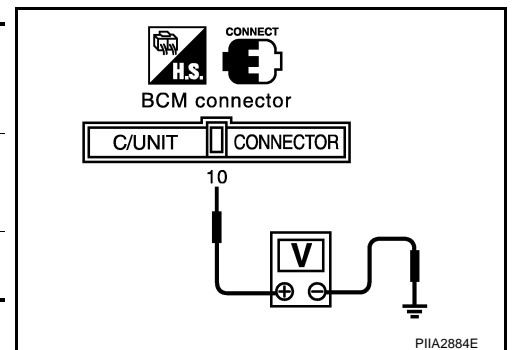

#### OK or NG

- OK >> Rear window defogger switch is OK.  
 NG >> GO TO 2

# REAR WINDOW DEFOGGER

## 2. REAR WINDOW DEFOGGER SWITCH SIGNAL CIRCUIT INSPECTION

1. Turn ignition switch OFF.
2. Disconnect BCM and multifunction switch (rear window defogger with) connectors.
3. Check continuity between BCM connector M4 terminal 10 and multifunction switch (rear defogger switch) connector M83 terminal 5.

**10 (G/R) – 5 (G/R) :Continuity should exist**

4. Check continuity between BCM harness connector M4 terminal 10 and ground

**10 (G/R) – Ground :Continuity should not exist**

OK or NG

OK >> GO TO 3.

NG >> Repair or replace harness between BCM and multifunction switch (rear window defogger switch).

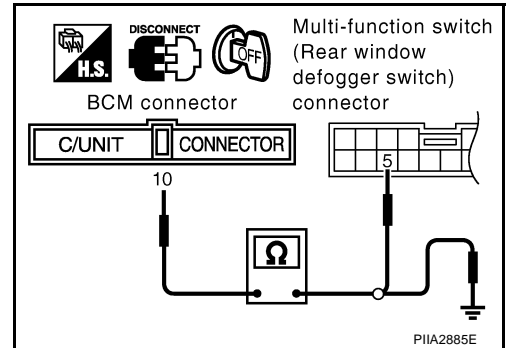

## 3. MULTIFUNCTION (REAR WINDOW DEFOGGER) SWITCH GROUND HARNESS INSPECTION

Check continuity between multi-function switch (rear window defogger switch) connector M83 terminal 2 and ground.

**2 (B) – Ground :Continuity should exist**

OK or NG

OK >> Replace multi function switch.

NG >> Repair or replace harness between multifunction switch (rear window defogger switch) and ground.

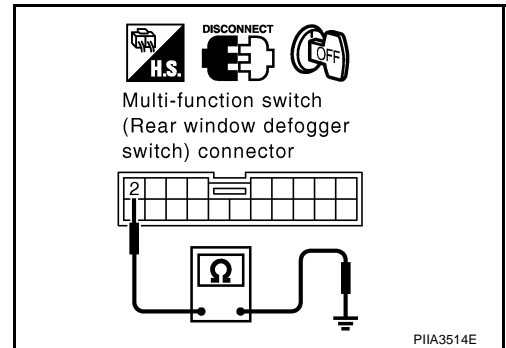

## Rear Window Defogger and Door Mirror Defogger Circuit Check

EIS008G3

### 1. CHECK FUSE

Check if any of the following fuses for Fuse block (J/B) are blown.

System	Terminal No. (signal)	Power source	Fuse No.	Ampere (A)
Rear defogger	8H	BAT power supply	#10	20
	3H	BAT power supply	#11	20
	2J	IGN power supply	#1	10

**NOTE:**

Refer to [GW-60. "Component Parts and Harness Connector Location"](#) .

OK or NG

OK >> GO TO 2.

NG >> If fuse is blown, be sure to eliminate cause of malfunction before installing new fuse, refer to [PG-2. "POWER SUPPLY ROUTING"](#) .

# REAR WINDOW DEFOGGER

## 2. CHECK REAR WINDOW DEFOGGER AND DOOR MIRROR DEFOGGER RELAY POWER SUPPLY CIRCUIT

1. Turn ignition switch OFF.
2. Disconnect rear window defogger and door mirror defogger relay.
3. Check voltage between rear window defogger and door mirror defogger relay connector B8 terminal 1, 3, 6 and ground.

Connector	Terminals (Wire color)		Power source	Condition	Voltage [V] (Approx.)
	(+)	(-)			
B8	1 (W/G)	Ground	IGN power supply	Ignition switch OFF	Battery voltage
	3 (R/B)		BAT power supply	Ignition switch ON	
	6 (L)		BAT power supply	Ignition switch OFF	

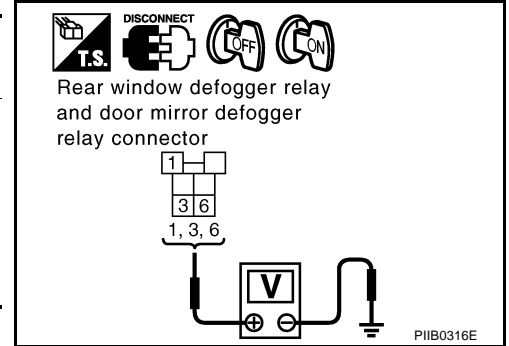

OK or NG

OK >> GO TO 3.

NG >> Check harness for open or short between rear window defogger and door mirror defogger relay and fuse.

## 3. REAR WINDOW DEFOGGER AND DOOR MIRROR DEFOGGER RELAY INSPECTION

With CONSULT-II

1. Connect the rear window defogger and door mirror defogger relay.
2. Check rear window defogger and door mirror defogger relay "REAR DEFOGGER RLY" in the ACTIVE TEST mode with CONSULT-II, Refer to [GW-68, "ACTIVE TEST"](#), check the operation.

**The operation sound of rear defogger relay is confirmed.**

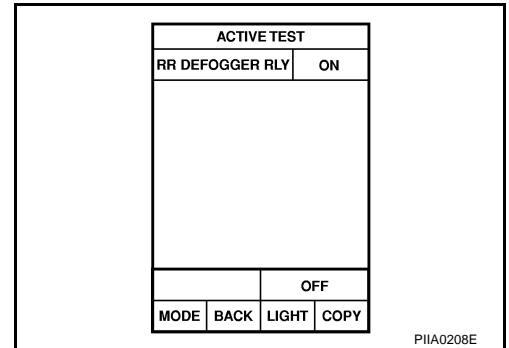

Without CONSULT-II

Check continuity between terminals 3 and 5, 6 and 7.

Terminal	Condition	Continuity
3	12V direct current supply between terminals 1 to 2	Should exist
	No current supply	Should not exist
6	12V direct current supply between terminals 1 to 2	Should exist
	No current supply	Should not exist

OK or NG

OK >> GO TO 4.

NG >> Replace rear window defogger and door mirror defogger relay.

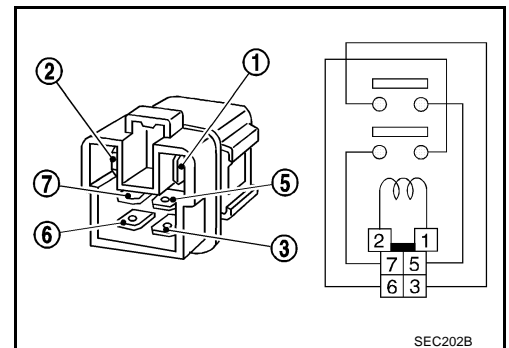

# REAR WINDOW DEFOGGER

## 4. CHECK REAR WINDOW DEFOGGER AND DOOR MIRROR DEFOGGER RELAY GROUND HARNESS

1. Turn ignition switch ON.
2. Turn rear window defogger switch OFF.
3. Installation rear window defogger and door mirror defogger relay.
4. Check voltage between BCM connector B4 terminal 144 and ground.

**144 (G/W) – Ground : Battery voltage**

OK or NG

- OK >> GO TO 5.  
NG >> GO TO 6.

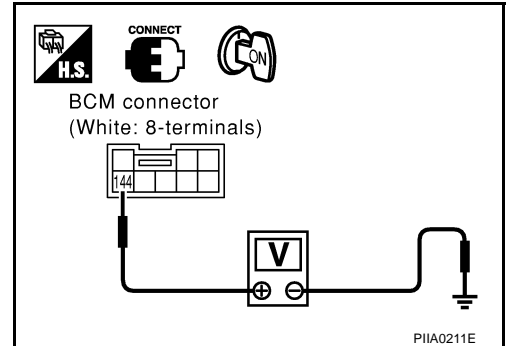

## 5. CHECK HARNESS CONTINUITY

1. Turn ignition switch OFF.
2. Disconnect condenser and rear window defogger remove door mirror defogger relay connectors.
3. Check continuity between condenser B25 terminal 1 and rear window and door mirror defogger relay connector B8 terminal 7.

**1 (LR) – 7 (L/R) :Continuity should exist.**

OK or NG

- OK >> Check the condition of the harness and the connector.  
NG >> Repair or replace harness between condenser and rear window defogger and door mirror defogger relay.

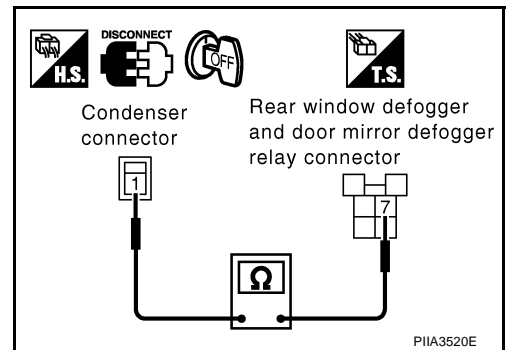

## 6. CHECK BCM HARNESS

1. Turn ignition switch OFF.
2. Disconnect BCM and rear window defogger and door mirror defogger relay connectors.
3. Check continuity between BCM connector B4 terminal 144 and rear window defogger and door mirror defogger relay connector B8 terminal 2.

**144 (G/W) – 2 (G/W) :Continuity should exist.**

OK or NG

- OK >> Check the condition of the harness and the connector.  
NG >> Repair or replace harness between BCM and rear window defogger and door mirror defogger relay.

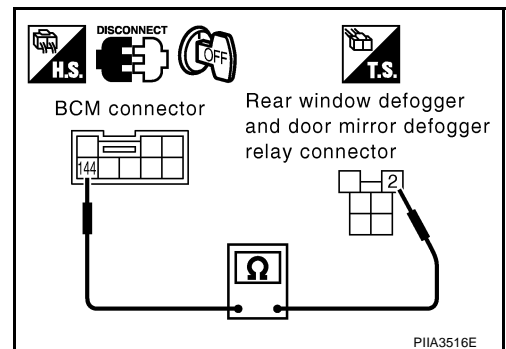



# REAR WINDOW DEFOGGER

EIS008G4

## Rear Window Defogger Circuit Check

### 1. CHECK REAR WINDOW DEFOGGER POWER SUPPLY CIRCUIT

1. Turn ignition switch OFF.
2. Disconnect rear window defogger connector.
3. Turn ignition switch ON.
4. Check voltage between rear window defogger connector and ground.

Con- nector	Terminal (Wire color)		Condition	Voltage [V] (Approx.)
	(+)	(-)		
B181	2 (B)	Ground	Rear window defogger switch ON.	Battery voltage
			Rear window defogger switch OFF.	0

OK or NG

- OK >> GO TO 2.  
NG >> GO TO 3.

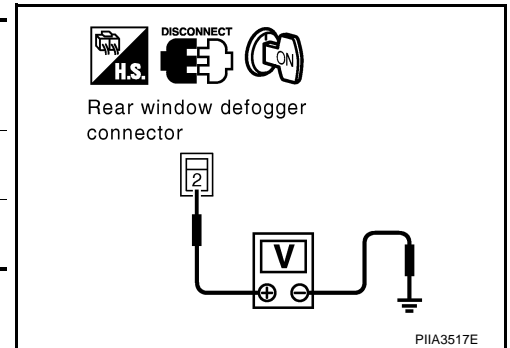

### 2. CHECK REAR WINDOW DEFOGGER GROUND HARNESS

1. Turn ignition switch OFF.
2. Check continuity between rear window defogger connector B421 terminal 1 and ground.

**1 (B) – Ground :Continuity should exist**

OK or NG

- OK >> Check filament, refer to [GW-77, "Filament Check"](#).
- If filament is OK, check the condition of the harness and the connector.
  - If filament is NG, repair filament.
- NG >> Repair or replace harness between rear window defogger and ground.

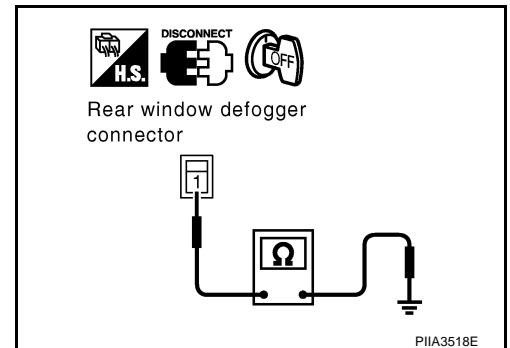

### 3. CHECK CONDENSER POWER SUPPLY CIRCUIT

1. Turn ignition switch OFF.
2. Disconnect condenser connector.
3. Turn ignition switch ON.
4. Check voltage between condenser connector and ground.

Con- nector	Terminal (Wire color)		Condition	Voltage [V] (Approx.)
	(+)	(-)		
B25	1 (L/R)	Ground	Rear window defogger switch ON.	Battery voltage
			Rear window defogger switch OFF.	0

OK or NG

- OK >> Repair or replace harness between condenser and rear window defogger.  
NG >> GO TO 4.

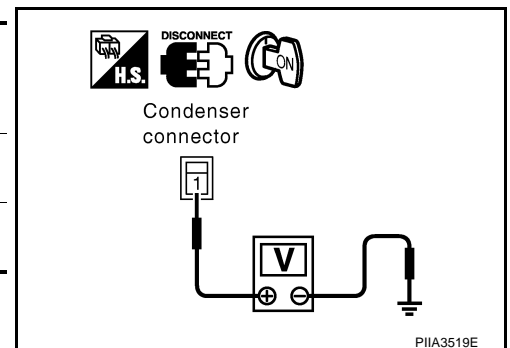

# REAR WINDOW DEFOGGER

## 4. CHECK CONDENSER HARNESS

1. Turn ignition switch OFF.
2. Disconnect rear window defogger and door mirror defogger relay connector.
3. Check continuity between condenser connector B25 terminal 1 and rear window defogger and door mirror defogger relay connector B8 terminal 7.

1 (L/R) – 7 (L/R) :Continuity should exist.

### OK or NG

- OK >> Check the condition of the harness and the connector.  
 NG >> Repair or replace harness condenser and rear window defogger and door mirror defogger relay.

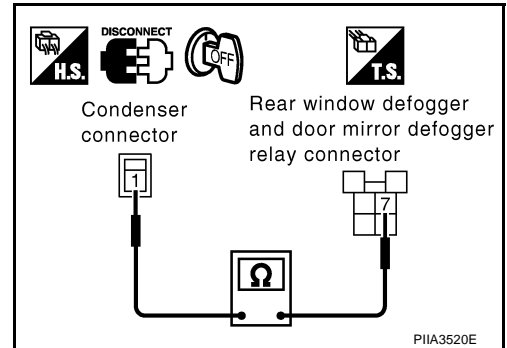

## Door Mirror Defogger Power Supply Circuit Check

EIS008G5

### 1. CHECK FUSE

Check if any of the following fuses for Fuse block (J/B) are blown.

System	Terminal No.	Power source	Fuse No.	Ampere (A)
Door mirror defogger	3A	AAC power supply	#4	10

### NOTE:

Refer to [GW-60, "Component Parts and Harness Connector Location"](#) .

### OK or NG

- OK >> GO TO 2.  
 NG >> If fuse is blown, be sure to eliminate cause of malfunction before installing new fuse, refer to [PG-2, "POWER SUPPLY ROUTING"](#) .

### 2. CHECK DOOR MIRROR DEFOGGER RELAY POWER SUPPLY CIRCUIT 1

1. Turn ignition switch OFF.
2. Remove door mirror defogger relay.
3. Turn ignition switch ON.
4. Check voltage between door mirror defogger relay connector and ground.

Con- nector	Terminal (Wire color)		Condition	Voltage [V] (Approx.)
	(+)	(-)		
B10	2 (L/R)	Ground	Rear window defogger switch ON.	Battery voltage
			Rear window defogger switch OFF.	0

### OK or NG

- OK >> GO TO 3.  
 NG >> Repair or replace between harness rear window defogger and door mirror defogger relay and door mirror defogger relay.

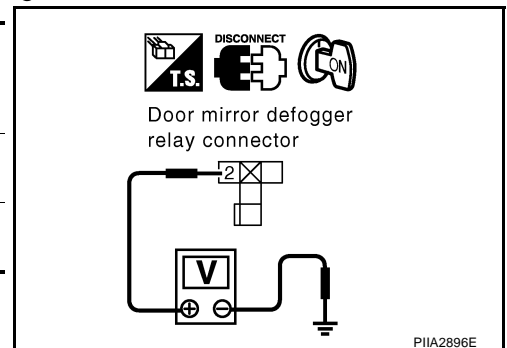

# REAR WINDOW DEFOGGER

## 3. CHECK DOOR MIRROR DEFOGGER RELAY

Check continuity between door mirror defogger relay terminals 3 and 5.

Terminal	Condition	Continuity
3	12V direct current supply between terminals 1 to 2	Should exist
5	No current supply	Should not exist

OK or NG

OK >> GO TO 4.

NG >> Replace door mirror defogger relay.

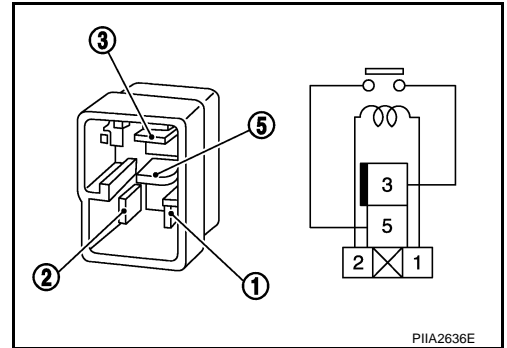

## 4. CHECK DOOR MIRROR DEFOGGER RELAY GROUND HARNESS

- Turn ignition switch OFF.
- Check continuity between door mirror defogger relay connector B10 terminal 1 and ground.

**1 (B) – Ground :Continuity should exist**

OK or NG

OK >> GO TO 5.

NG >> Repair or replace harness between door mirror defogger relay and ground.

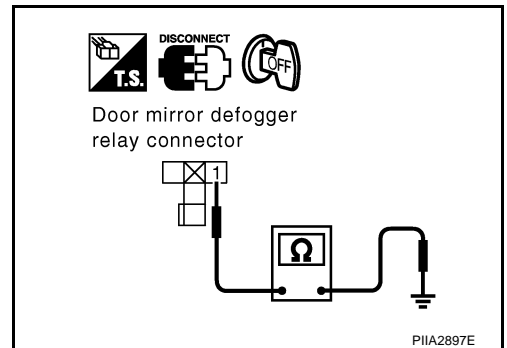

## 5. CHECK DOOR MIRROR DEFOGGER RELAY POWER SUPPLY CIRCUIT 2

Check voltage between door mirror defogger relay connector B10 terminal 5 and ground.

**5 (P/B) – Ground : Battery voltage**

OK or NG

OK >> GO TO 6.

NG >> Repair or replace harness between door mirror defogger relay and fuse.

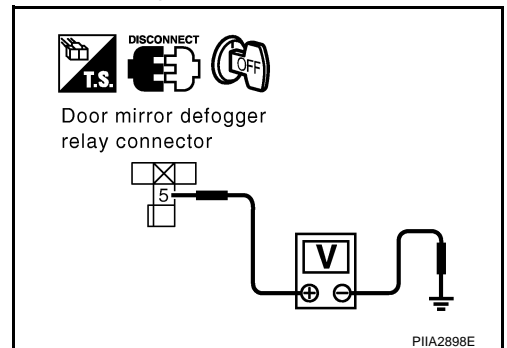

# REAR WINDOW DEFOGGER

## 6. CHECK DOOR MIRROR DEFOGGER POWER SUPPLY CIRCUIT

1. Connect door mirror defogger relay.
2. Turn ignition switch ON.
3. Check voltage between door mirror connector D2 (driver side) or D32 (passenger side) terminal 6 and ground.

Connector	Terminals (Wire color)		Condition	Voltage [V] (Approx.)
	(+)	(-)		
D2 D32	6 (L/R)	Ground	Rear window defogger switch ON	Battery voltage
			Rear window defogger switch OFF	0

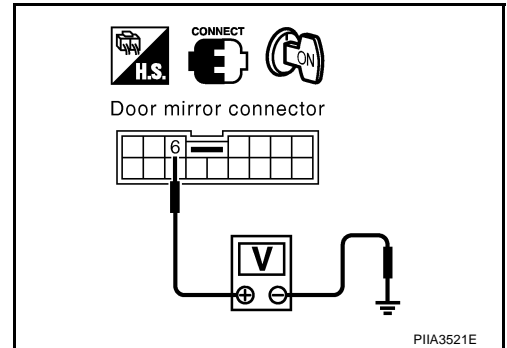

### OK or NG

OK >> INSPECTION END.

NG >> Repair or replace harness between malfunction door mirror and door mirror defogger relay.

## Driver Side Door Mirror Defogger Circuit Check

E/S008G6

### 1. CHECK DOOR MIRROR DEFOGGER POWER SUPPLY CIRCUIT

1. Turn ignition switch ON.
2. Check voltage between door mirror (driver side) connector and ground.

Con- nector	Terminal (Wire color)		Condition	Voltage [V] (Approx.)
	(+)	(-)		
D2	6 (L/R)	Ground	Rear window defogger switch ON.	Battery voltage
			Rear window defogger switch OFF.	0

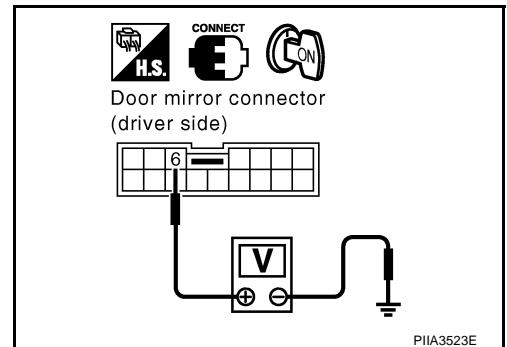

### OK or NG

OK >> GO TO 2.

NG >> Repair or replace harness between door mirror defogger relay and door mirror (driver side).

### 2. CHECK DOOR MIRROR DEFOGGER GROUND HARNESS

1. Turn ignition switch OFF.
2. Disconnect door mirror (driver side) connector.
3. Check continuity between driver side door mirror defogger connector D2 terminal 5 and ground.

**5 (B) – Ground : Continuity should exist.**

### OK or NG

OK >> Check the following, if it is OK, replace door mirror (driver side).

- Check the condition of the harness and the connector.
- Door mirror defogger firmament continuity check.

NG >> Repair or replace harness between driver side door mirror (driver side) and ground.

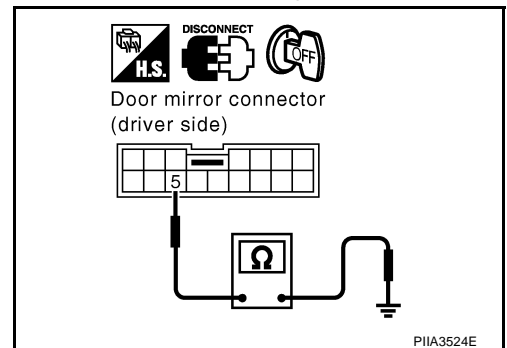

# REAR WINDOW DEFOGGER

## Passenger Side Door Mirror Defogger Circuit Check

EIS008G7

### 1. CHECK DOOR MIRROR DEFOGGER POWER SUPPLY CIRCUIT

1. Turn ignition switch ON.
2. Check voltage between door mirror (passenger side) connector and ground.

Con- nector	Terminal (Wire color)		Condition	Voltage [V] (Approx.)
	(+)	(-)		
D32	6 (L/R)	Ground	Rear window defogger switch ON.	Battery voltage
			Rear window defogger switch OFF.	0

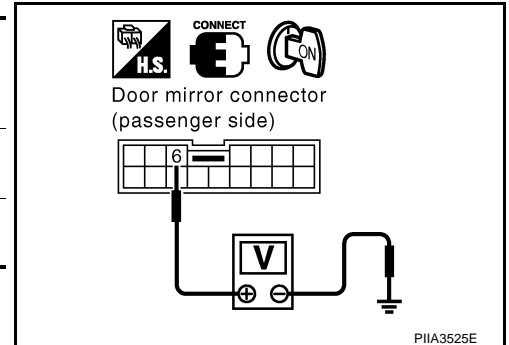

OK or NG

OK >> GO TO 2.

NG >> Repair or replace harness between door mirror defogger relay and door mirror (passenger side).

### 2. CHECK DOOR MIRROR DEFOGGER GROUND HARNESS INSPECTION

1. Turn ignition switch OFF.
2. Disconnect door mirror (passenger side) connector.
3. Check continuity between door mirror (passenger side) connector D32 terminal 5 and ground.

**5 (B) – Ground : Continuity should exist.**

OK or NG

OK >> Check the following, if it is OK, replace door mirror passenger side.

- Check the condition of the harness and the connector.
- Door mirror defogger firmament continuity check.

NG >> Repair or replace harness between door mirror (passenger side) and ground.

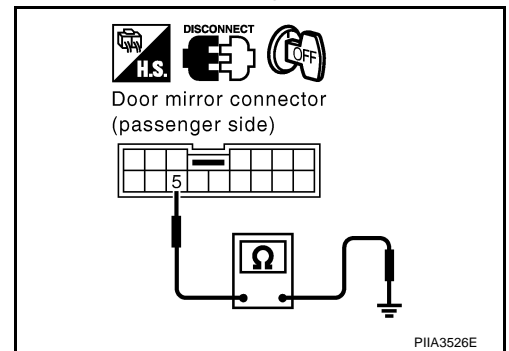

### Filament Check

EIS008G8

1. When measuring voltage, wrap tin foil around the top of the negative probe. Then press the foil against the wire with your finder.

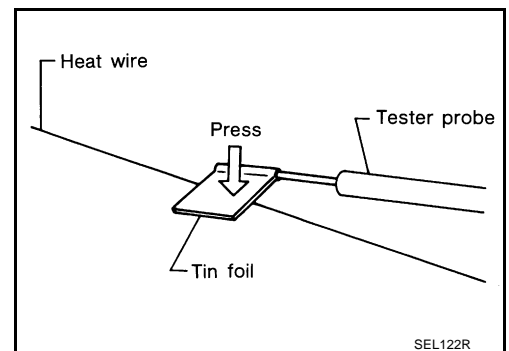

# REAR WINDOW DEFOGGER

- Attach probe circuit tester (in Volt range) to middle portion of each filament.

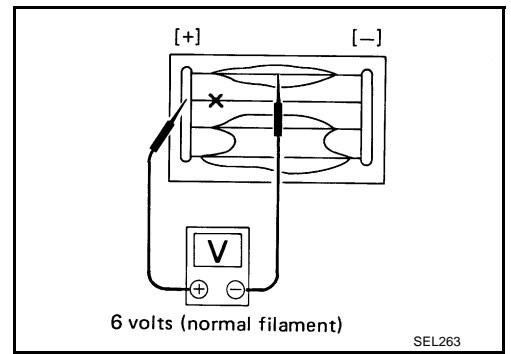

- If a filament is burned out, circuit tester registers 0 or battery voltage.
- To locate burned out point, move probe to left and right along filament. Test needle will swing abruptly when probe passes the point.

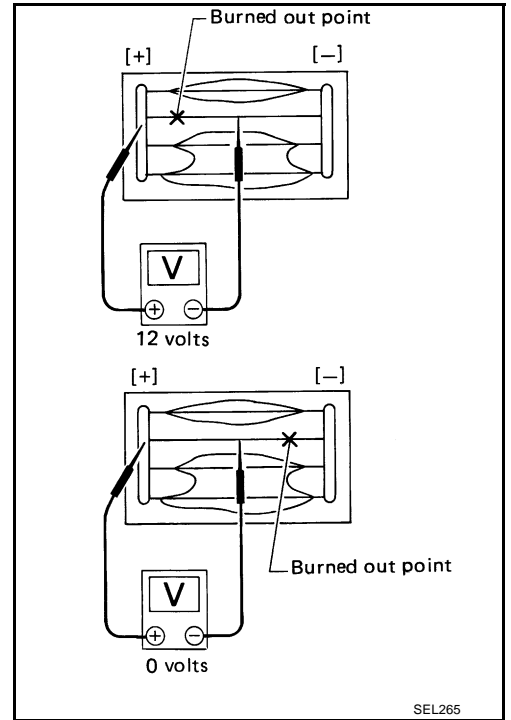

## Filament Repair REPAIR EQUIPMENT

- Conductive silver composition (Dupont NO.4817 or equivalent)
- Ruler 30 cm(11.8in) long
- Drawing pen
- Heat gun
- Alcohol
- Cloth

## REPAIRING PROCEDURE

- Wipe broken heat wire and its surrounding area clean with a cloth dampened alcohol.
- Apply a small amount of conductive silver composition to tip of drawing pen. Shake silver composition container before use.
- Place ruler on glass along broken line. Deposit conductive silver composition on break with drawing pen. Slightly overlap existing heat wire on both sides [preferably 5 mm(0.20in)] of the break.

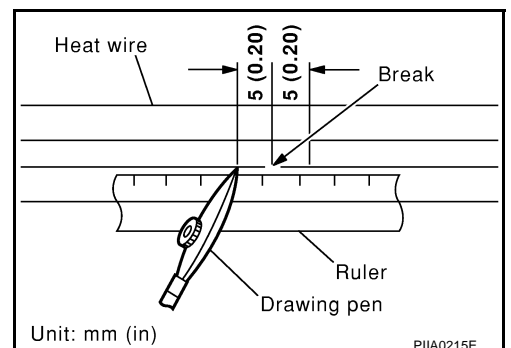

## REAR WINDOW DEFOGGER

4. After repair has been completed, check repaired wire for continuity. This check should be conducted 10 minutes after silver composition is deposited. Do not touch repaired area while test is being conducted.

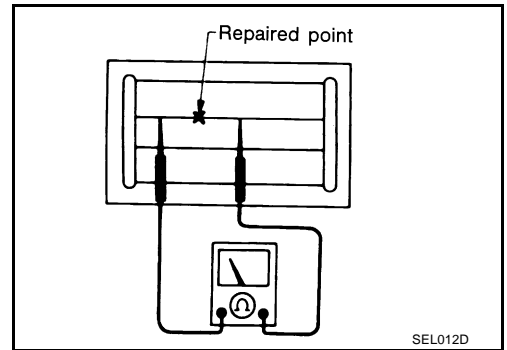

5. Apply a constant stream of hot air directly to the repaired area for approximately 20 minutes with a heat gun. A minimum distance of 3cm (1.2in) should be kept between repaired area and hot air outlet. If a heat gun is not available, let the repaired area dry for 24 hours.

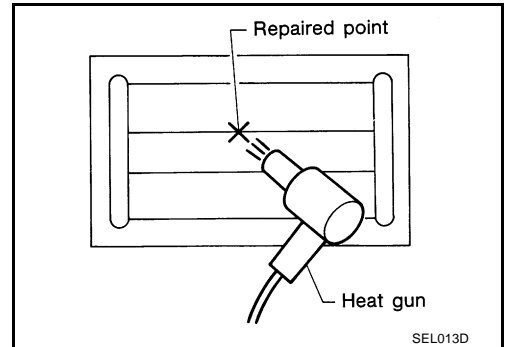

A  
B  
C  
D  
E  
F  
G  
H

GW

J  
K  
L  
M

# REVERSE INTERLOCK DOOR MIRROR SYSTEM

PFP:28548

## REVERSE INTERLOCK DOOR MIRROR SYSTEM

### System Description

EIS008GA

- When switching the door mirror remote control switch position (LH/RH), the system moves driver or passenger door mirror face downward, in relation to the A/T selector lever being shifted to Reverse Position.
- The mirror position with the reverse gear engaged can be adjusted and the adjusted mirror position can be stored in memory (2 positions).
- With reverse gear-linked operation signal, the door mirror control unit– driver side / passenger side (LCU) installed on the door panel drives and controls the motors (UP/DOWN, LH/RH).
- Using the self-diagnostic function and CONSULT-II, system diagnosis can be performed.

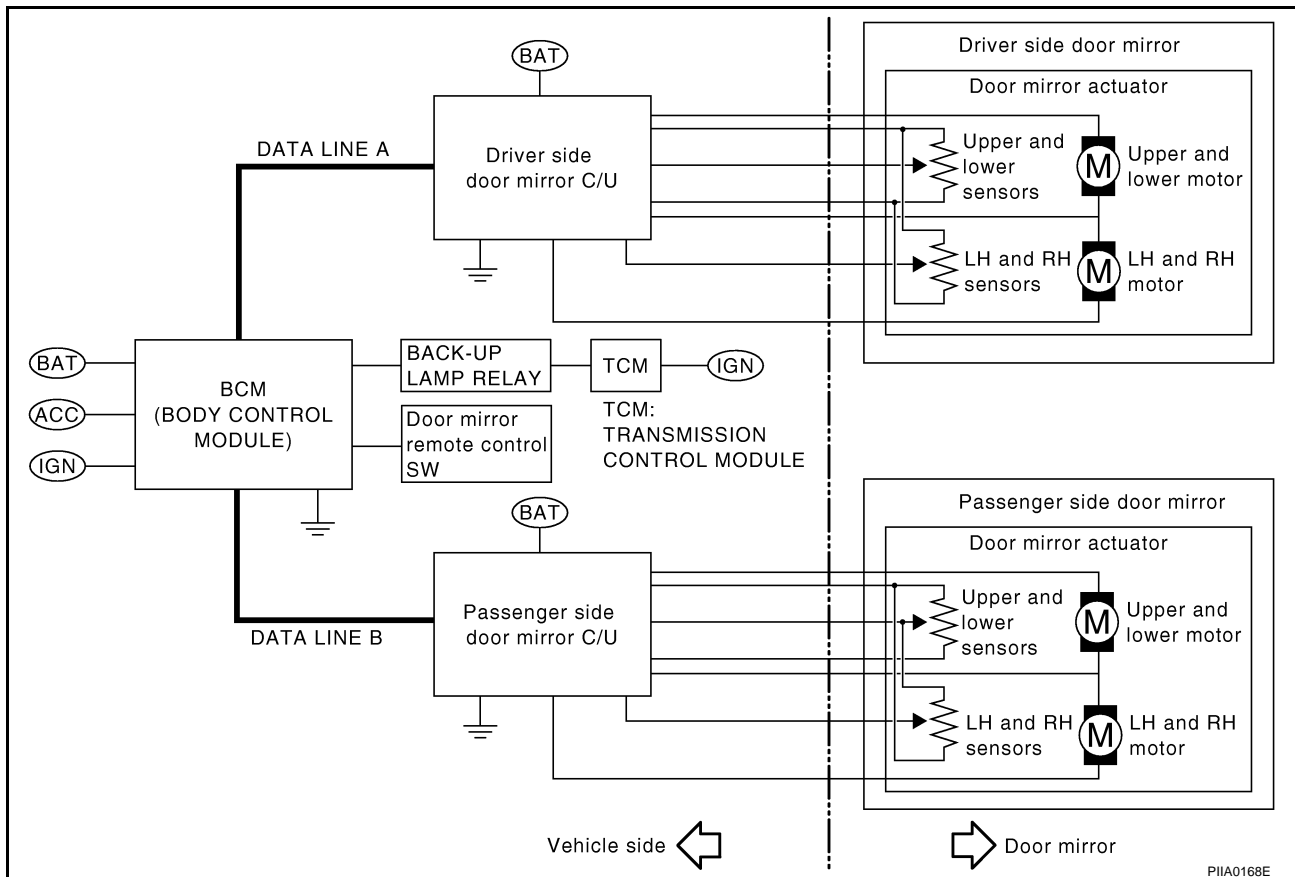

### OUTLINE OF OPERATION

#### Operation Conditions

If all of the following conditions are satisfied, starts operating after approximately 0.5 seconds.

- Ignition switch is in ON position.
- Set the door mirror remote control switch from the neutral position to right position, or left position.
- A/T selector lever is in R position.

#### NOTE:

- If the conditions for reverse gear-linked operation are satisfied during manual operation, the manual operation is interrupted and switched to the reverse gear-linked operation.

#### Operation Angle

##### Fixed operation angle

	Facing downward	Facing innerward
Driver-side	7°	1°
Passenger-side	7°	1°



# REVERSE INTERLOCK DOOR MIRROR SYSTEM

## End of Operation

If one of the following conditions is satisfied, the reverse gear-linked operation is stopped.

- When the set angle is reached.
- When no operation signal or no operation end signal can be received for approximately 2 seconds or more after BCM actually outputs the reverse gear-linked operation signal.
- After receiving the operation signal from the door mirror control unit, when BCM has stayed in the status for 60 seconds.

## Return Operation

If one of the following conditions is satisfied, the mirror face returns upward.

- When the ignition switch is turned OFF.
- When the A/T selector lever is shifted to any position except R position.
- When the door mirror remote control switch is in the neutral position.

### NOTE:

- After the above operation, if no operation conditions previously mentioned are satisfied, shifting the A/T selector lever to R position will not move the mirror face downward.

## End of Return Operation

- Mirror face returns to the original position.
- When no operation signal or no operation end signal can be received for approximately 2 seconds or more after BCM actually outputs the reverse gear-linked operation signal.
- After receiving the operation signal from the door mirror control unit, when BCM has stayed in the status for 60 seconds.

## MIRROR POSITION MEMORY FUNCTIONS

Equipped with a function which allows memorizing the desired mirror face positions (2 positions each for LH/RH door mirror).

### Memory Operation Conditions

The seat and steering wheel positions are in accordance with memory 1 or memory 2 in the automatic drive position control. Refer to [SE-13, "AUTOMATIC DRIVE POSITIONER"](#).

### Memory Operation Procedure

1. Turn ignition switch ON.
2. Shift the A/T selector lever to R position.
3. Switch the door mirror remote control switch to right or left, and set the mirror face to the desired angle.
4. Press the setting button, and within 5 seconds, press the memory switch which stores the current seat and steering wheel positions for 0.5 seconds or more.
5. If the memory switch with certain positions stored is used, it turns off for 0.5 seconds after the operation, and after that it illuminates continuously (for approx. 5 seconds).
6. If a memory switch with no positions stored is used, it illuminates (for approx. 5 seconds) after the memory switch operation.

## POWER SUPPLY AND GROUND

Power is supplied at all times

- through 10A fuse[No.8,located in the fuse block (J/B)]
- to driver side door mirror control unit terminal 8 and
- to passenger side door mirror remote control unit terminal 8
- through 10A fuse[No.3,located in the fuse block (J/B)]
- to BCM terminal 105.

When ignition switch is ON or START position,  
Power is supplied

- through 10A fuse[No.9,located in the fuse block (J/B)]
- to TCM terminal 41.

BCM is connected to LCU03 and LCU04 as DATA LINE A-2 and DATA LINE A-3.

When door mirror remote control switch is turned left or right,

# REVERSE INTERLOCK DOOR MIRROR SYSTEM

ground is supplied

- to BCM terminal 24 or 21
- through door mirror remote control switch terminal 6 or 5.

When selector lever is R position,  
ground is supplied

- to back-up lamp relay terminal 1.
- through TCM terminal 41.

Then, back-up lamp relay is energized,  
When back-up lamp relay is energized,  
Power is supplied

- to BCM terminal 141.
- through back-up lamp relay terminal 3.

Then signal input to driver side door mirror control unit and passenger side door mirror control unit terminal 7 from BCM terminal 61 and 67 by DATA LINE A-2 and DATA LINE A-3.

## Component Parts and Harness Connector Location

EIS008GB

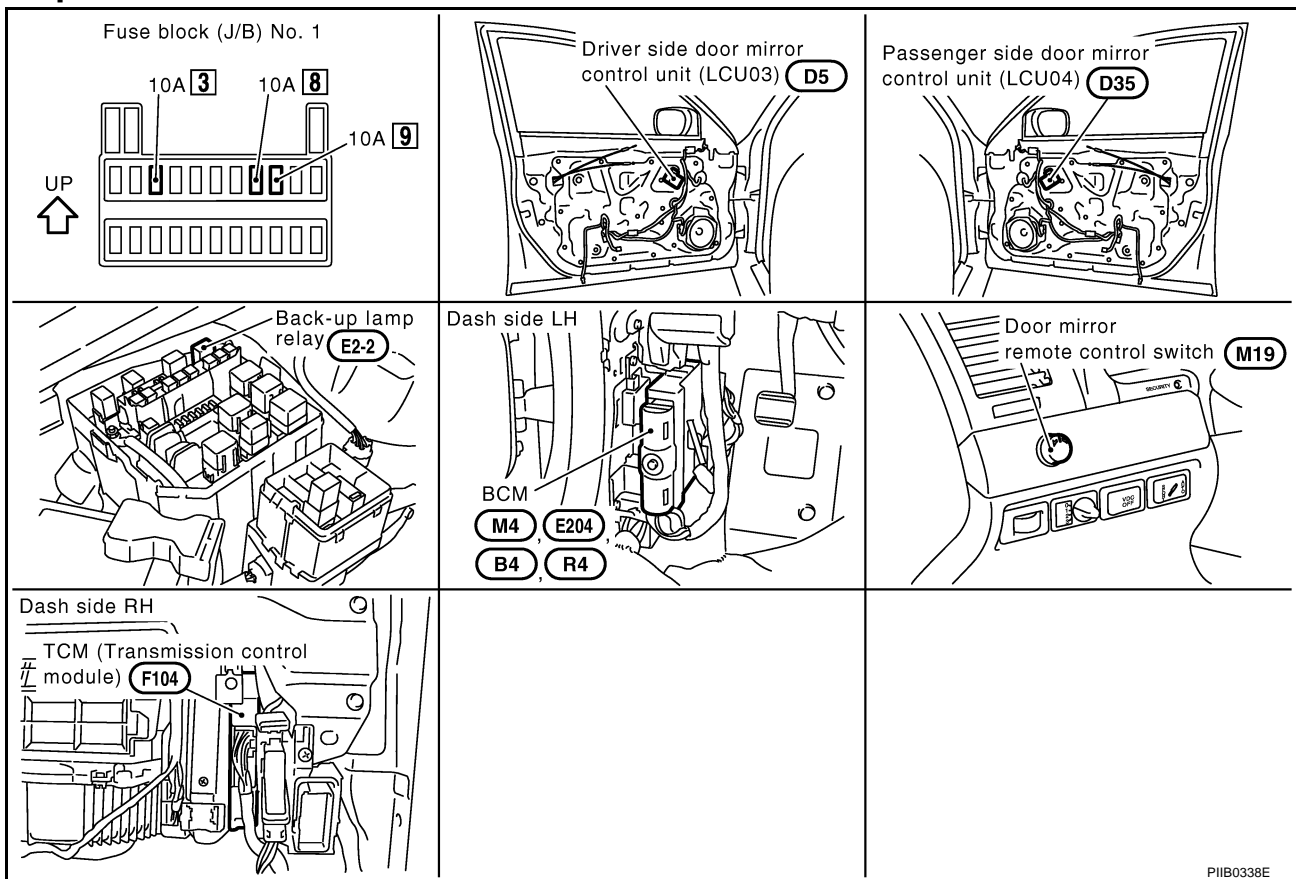

PIIB0338E

# REVERSE INTERLOCK DOOR MIRROR SYSTEM

## Schematic

EIS008GC

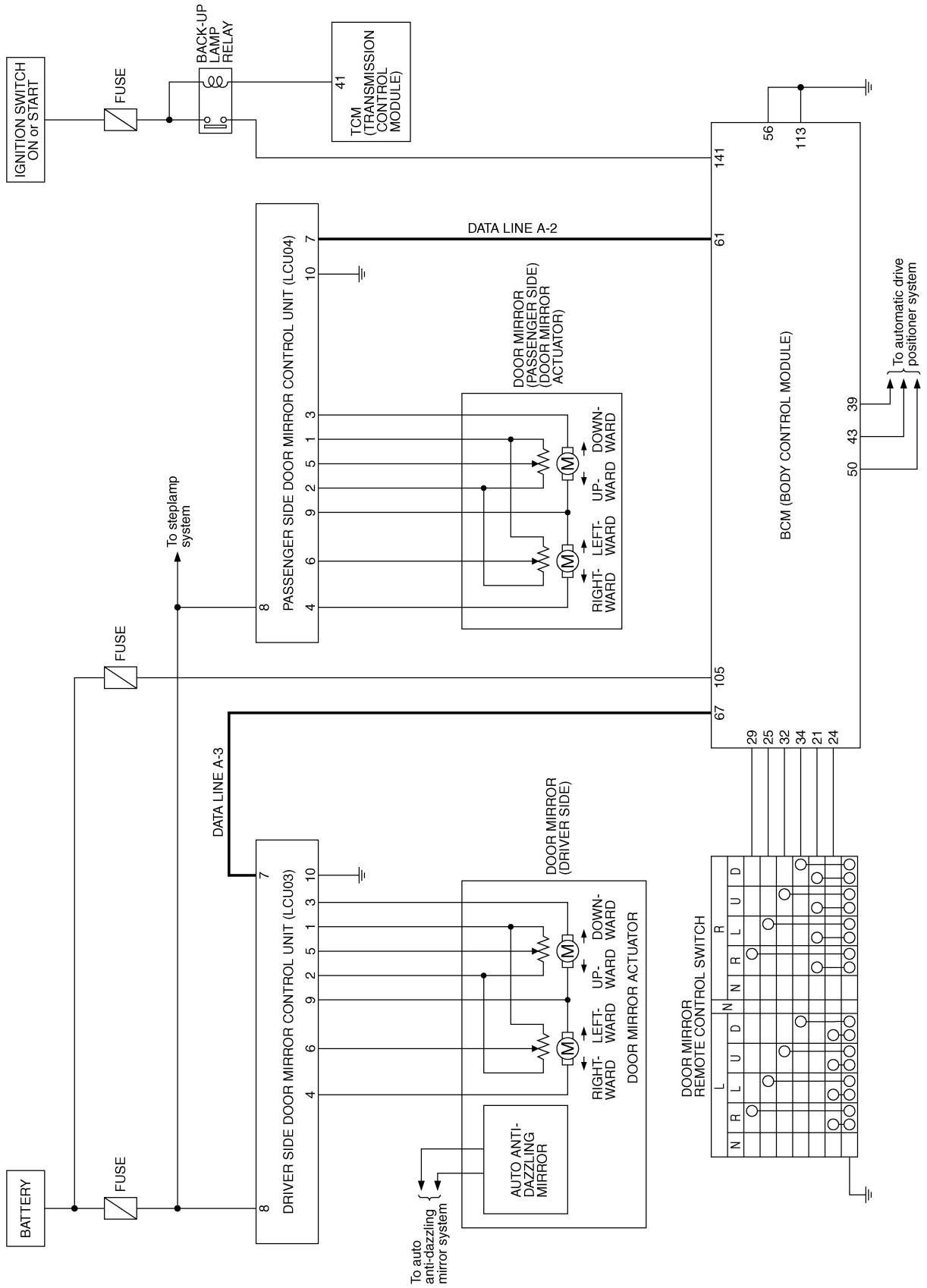

A  
B  
C  
D  
E  
F  
G  
H  
J  
K  
L  
M

GW



# REVERSE INTERLOCK DOOR MIRROR SYSTEM

GW-MIRROR-02

DATA LINE

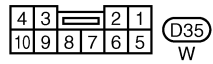
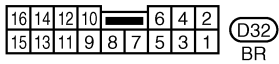
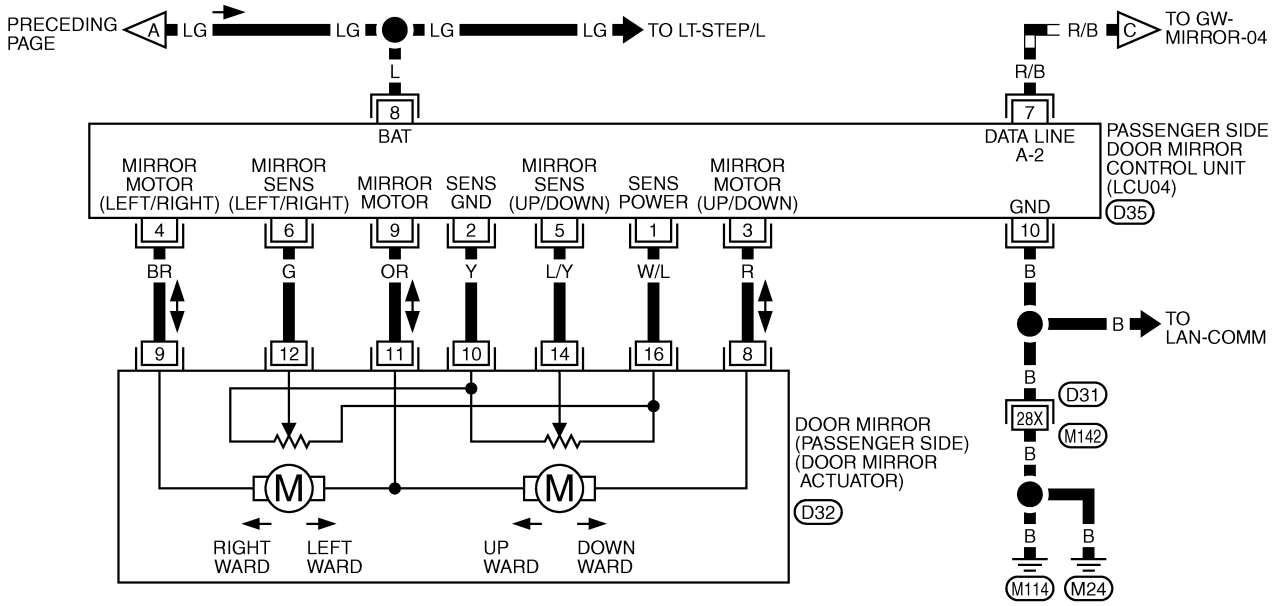

REFER TO THE FOLLOWING.

D31 -SUPER MULTIPLE JUNCTION (SMJ)

# REVERSE INTERLOCK DOOR MIRROR SYSTEM

GW-MIRROR-03

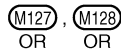
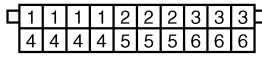
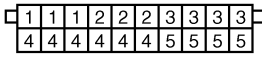
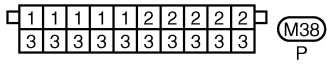
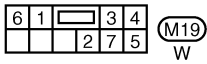
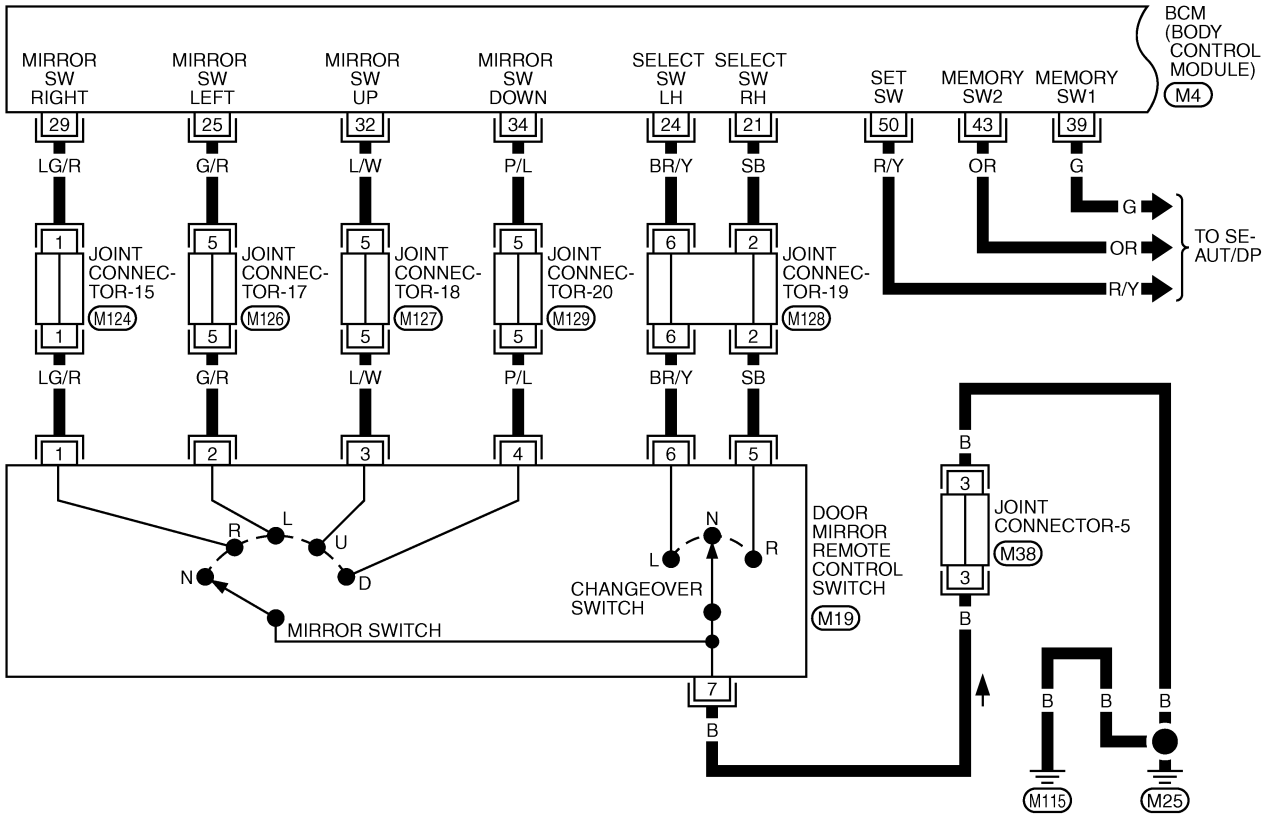

REFER TO THE FOLLOWING.  
(M4) -ELECTRICAL UNITS

# REVERSE INTERLOCK DOOR MIRROR SYSTEM

GW-MIRROR-04

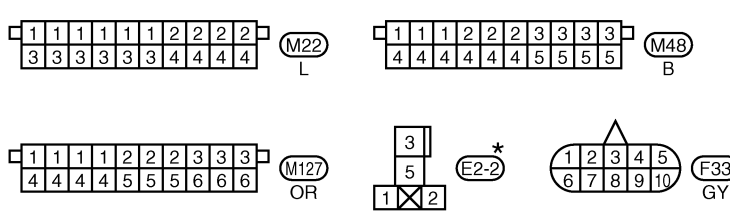
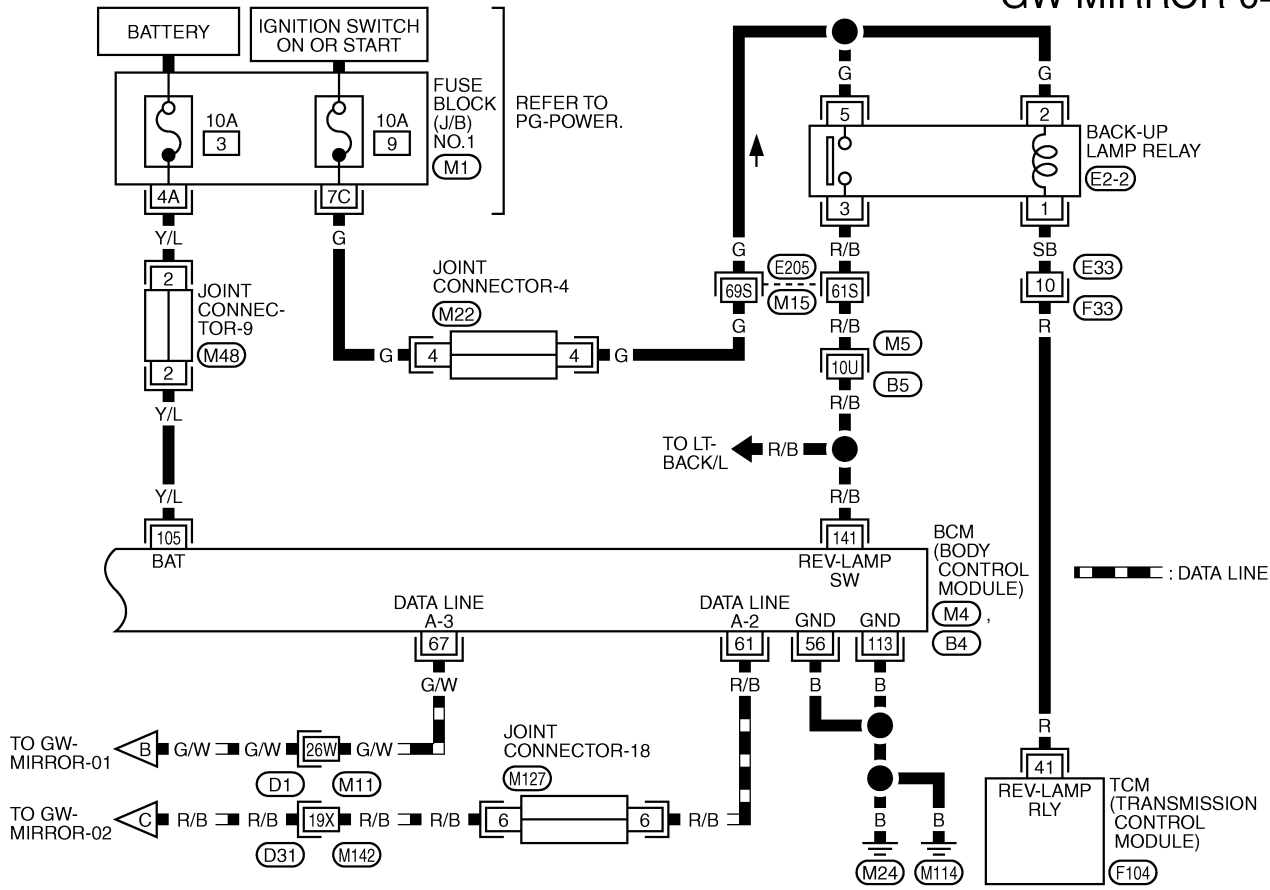

\*: THIS CONNECTOR IS NOT SHOWN IN "HARNESS LAYOUT", PG SECTION.

REFER TO THE FOLLOWING.  
 (M5), (E205), (D1), (D31)  
 -SUPER MULTIPLE JUNCTION (SMJ)  
 (M1) -FUSE BLOCK-JUNCTION BOX (J/B) NO.1  
 (M4), (F104), (B4)  
 -ELECTRICAL UNITS

TIVM0220E

## Terminals and Reference Values for Driver Side Door Mirror Control Unit and Passenger Side Door Mirror Control Unit

EIS008GE

TERMI-NAL	WIRE COLOR	ITEM	CONDITION	VOLTAGE [V] (Approx.)
3	GY/R (R)	Mirror motor UP signal	When motor is activated (UP)	Battery voltage
			When motor is not activated	0
4	BR	Mirror motor LH signal	When motor is activated (LH)	Battery voltage
			When motor is not activated	0
5	L/Y	Mirror sensor UP/ DOWN signal	When motor is activated (UP or DOWN)	Changes between 4 (close to perk) – 0.5 (close to valley)

## REVERSE INTERLOCK DOOR MIRROR SYSTEM

TERMI-NAL	WIRE COLOR	ITEM	CONDITION	VOLTAGE [V] (Approx.)
6	G	Mirror sensor LH / RH signal	When motor is activated (LH or RH)	Changes between 4 (close to right edge) – 0.5 (close to left edge)
7	R/B	Data line A-3	—	—
8	L	Power source (Fuse)	—	Battery voltage
9	PU/W (OR)	Mirror motor DOWN signal	When motor is activated (DOWN)	Battery voltage
			When motor is not activated	0
		Mirror motor RH signal	When motor is activated (RH)	Battery voltage
			When motor is not activated	0
10	B	Ground	—	0

( ): Passenger side door mirror control unit.

### Terminals and Reference Values for BCM

EIS008GF

TERMI-NAL	WIRE COLOR	ITEM	CONDITION	VOLTAGE [V] (Approx.)
21	SB	Door mirror LH / RH switching signal – RH	Set the door mirror control switch to right position.	0
			Other than above	5
24	BR/Y	Door mirror LH / RH switching signal – LH	Set the door mirror remote control switch to left position.	0
			Other than above	5
25	G/R	Door mirror remote control switch signal – LH operation	Set the either LH/RH door mirror face to left.	0
			Other than above	5
29	LG/R	Door mirror remote control switch signal – RH operation	Set the either LH/RH door mirror face to right.	0
			Other than above	5
32	L/W	Door mirror remote control switch signal – Upward	Set the either LH/RH door mirror face upward.	0
			Other than above	5
34	P/L	Door mirror remote control switch signal – Downward	Set the either LH/RH door mirror face downward.	0
			Other than above	5
39	G	Memory switch1 signal	Memory switch1 (ON)	0
			Memory switch1 (OFF)	5
43	OR	Memory switch2 signal	Memory switch2 (ON)	0
			Memory switch2 (OFF)	5
50	R/Y	Set switch signal	Set switch (ON)	0
			Set switch (OFF)	5
56	B	Ground	—	0
61	R/B	Data line A – 2	—	—
67	G/W	Data line A – 3	—	—
105	Y/L	Power source (Fuse)	—	Battery voltage
113	B	Ground	—	0
141	R/B	R position signal	When the selector lever is in R position	Battery voltage
			When the selector lever is not in R position	0



# REVERSE INTERLOCK DOOR MIRROR SYSTEM

EIS008GG

## Work Flow

1. Check the symptom and customer's requests.
2. Understand the system description. Refer to [GW-80, "System Description"](#) .
3. Carry out the preliminary check. Refer to [GW-89, "Preliminary Check"](#) .
4. Carry out the communication inspection.  
If CONSULT-II is used, refer to [GW-92, "IVMS COMMUNICATION INSPECTION"](#) .  
If CONSULT-II is not used, refer to [GW-99, "COMMUNICATION DIAGNOSIS"](#) .  
Is the communication diagnosis result OK?  
If OK, GO TO 7.  
If NG, GO TO 5.
5. Repair or replace depending on the diagnosis result.
6. Carry out the communication diagnosis again.  
If CONSULT-II is used, refer to [GW-92, "IVMS COMMUNICATION INSPECTION"](#) .  
If CONSULT-II is not used, refer to [GW-99, "COMMUNICATION DIAGNOSIS"](#) .  
Is communication diagnosis result OK?  
If OK, GO TO 7.  
If NG, GO TO 5.
7. Perform self-diagnosis.  
If CONSULT-II is used, refer to [GW-91, "CONSULT-II BASIC OPERATION PROCEDURE"](#) .  
If CONSULT-II is not used, refer to [SE-51, "ON BOARD DIAGNOSIS FOR AUTOMATIC DRIVE POSITIONER"](#) .  
Is self-diagnosis result OK?  
If OK, GO TO 11.  
If NG, GO TO 8.
8. Repair or replace depending on the diagnosis result.
9. Carry out the self-diagnosis again.  
If CONSULT-II is used, refer to [GW-91, "CONSULT-II BASIC OPERATION PROCEDURE"](#) .  
If CONSULT-II is not used,  
refer to [SE-51, "ON BOARD DIAGNOSIS FOR AUTOMATIC DRIVE POSITIONER"](#) .  
Is self-diagnosis result OK?  
If OK, GO TO 11.  
If NG, GO TO 8.
10. Referring to Trouble diagnosis chart, repair or replace the cause of the malfunction. Refer to [GW-106, "Symptom Chart"](#) .
11. Does the Reverse Interlock Door Mirror System operate normally?  
If it operates normally, GO TO 12.  
If not, GO TO 10.
12. Inspection end

## Preliminary Check

### POWER SUPPLY AND GROUND CIRCUIT INSPECTION

EIS008GH

#### 1. CHECK FUSE.

Check that any of the following fuses in BCM and door mirror control unit are blown.

Unit	Terminal No.	Power source	Fuse No.
BCM	105	BAT power supply	#3
Door Mirror Control Unit (Driver side & Passenger side)	8	BAT power supply	#8

#### NOTE:

Refer to [GW-82, "Component Parts and Harness Connector Location"](#) .

#### OK or NG

OK >> GO TO 2

NG >> If fuse is blown, be sure to eliminate cause of problem before installing new fuse. Refer to [PG-2, "POWER SUPPLY ROUTING"](#) .

# REVERSE INTERLOCK DOOR MIRROR SYSTEM

## 2. POWER SUPPLY CIRCUIT INSPECTION(BCM)

1. Turn ignition switch OFF.
2. Disconnect BCM connector.
3. Check voltage between BCM connector M4 terminal 105 and ground.

**105 (Y/L) – Ground** :Battery voltage

OK or NG

OK >> GO TO 3

NG >> Repair or replace the harnesses for BCM power supply circuit.

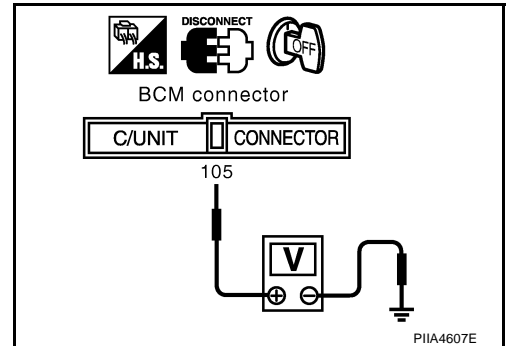

## 3. GROUND CIRCUIT INSPECTION(BCM)

1. Turn ignition switch OFF.
2. Check continuity between BCM connector M4 terminal 56, 113 and ground.

**56 (B) – Ground** :Continuity should exist.

**113 (B) – Ground** :Continuity should exist.

OK or NG

OK >> GO TO 4

NG >> Repair or replace harness.

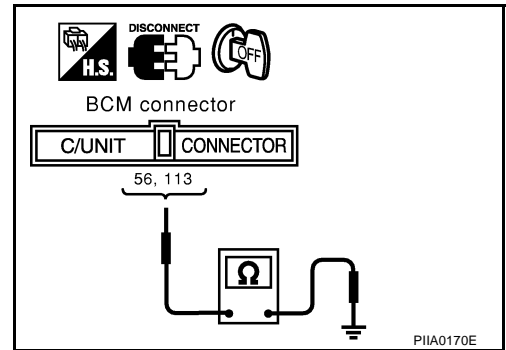

## 4. POWER SUPPLY CIRCUIT INSPECTION (DOOR MIRROR CONTROL UNIT)

Check voltage between door mirror control unit connector D5 (driver side), D35 (passenger side) terminal 8 and ground.

**8 (L) – Ground** :Battery voltage

OK or NG

OK >> GO TO 5

NG >> Repair or replace harness.

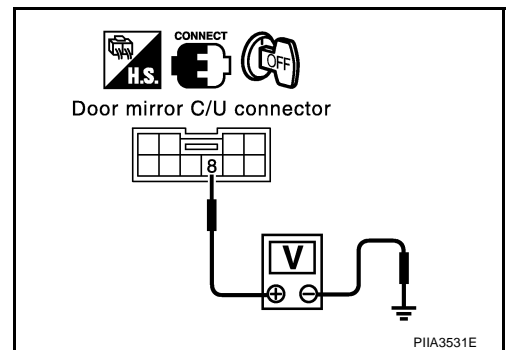

# REVERSE INTERLOCK DOOR MIRROR SYSTEM

## 5. GROUND CIRCUIT INSPECTION (DOOR MIRROR CONTROL UNIT)

1. Disconnect door mirror control unit connector.
2. Check continuity between door mirror control unit connector D5 (driver side), D35 (passenger side) terminal 10 and ground.

**10 (B) – Ground :Continuity should exist.**

OK or NG

- OK >> Preliminary check is OK.  
 NG >> Repair or replace harness.

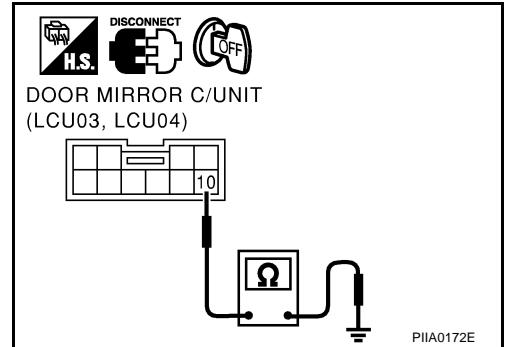

## CONSULT-II Function

EIS008G1

- CONSULT-II executes the following functions by combining data received and command transmitted via the communication line from BCM. IVMS communication inspection, work support (only function setting of seats and steering wheel), self-diagnosis, data monitor, and active test display.

IVMS diagnosis position	Inspection item and diagnosis mode	Description
IVMS-COMM CHECK	IVMS-COMM DIAGNOSIS	Diagnose a communication malfunction, inactive communication, and sleep malfunction in the communication line between BCM and each LCU.
	WAKE-UP DIAGNOSIS	Diagnose the wake-up signals output from each LCU.
AUTO DRIVE POSITIONER	WORK SUPPORT*	Changes the setting for each function. Refer to <a href="#">SE-36. "SETTING CHANGE FUNCTION"</a> .
	SELF-DIAG RESULTS	Carries out the self-diagnosis.
	DATA MONITOR	Displays the input data of BCM and each LCU on real-time basis.
	ACTIVE TEST	Sends a drive signal to a load to check the operation.
BCM PART NUMBER		Displays BCM part No.

\*: Only for function setting of seat and steering wheel

## CONSULT-II BASIC OPERATION PROCEDURE

1. Turn ignition switch "OFF".
2. Connect "CONSULT-II" and CONSULT-II CONVERTER to data link connector.

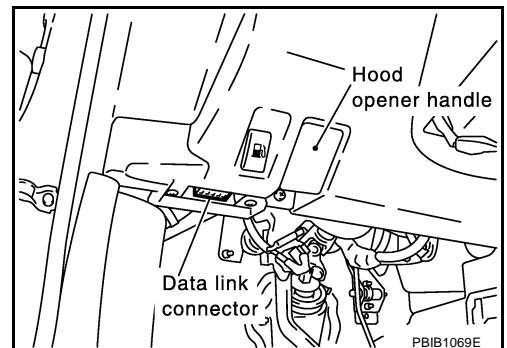

# REVERSE INTERLOCK DOOR MIRROR SYSTEM

3. Turn ignition switch "ON".
4. Touch "START(NISSAN BASED VHCL)".

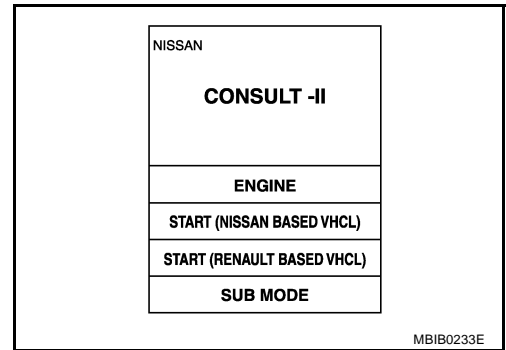

5. Touch "IVMS" on the "SELECT SYSTEM" screen. If "BCM" is not indicated, go to Refer to [GI-38](#) , "CONSULT-II Date Link Connector (DLC) Circuit".

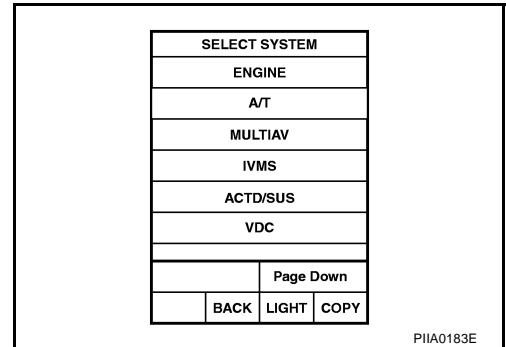

6. Check the model specification, and touch either "WITH SUNROOF" or "WITHOUT SUNROOF" on the "SELECT SYS COND" screen.
7. Touch "OK". If the selection is wrong, touch "CANCEL".
8. Select the desired part to be diagnosed on the "SELECT TEST ITEM" screen.

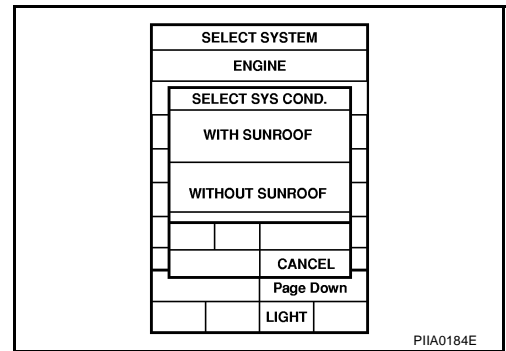

## IVMS COMMUNICATION INSPECTION

- IVMS contains the IVMS communication diagnosis and wake-up diagnosis.

### IVMS Communication Diagnosis

- The IVMS communication diagnosis consists of the communication diagnosis, sleep diagnosis, and inactive communication diagnosis between BCM and each local unit (LCU), and display the results on the CONSULT-II screen.

**NOTE:**

Sleep is a power saving function when a vehicle is stationary (all BCM related electrical equipment: OFF, and the timer: OFF).

- The function also stores the communication malfunction records and inactive communication records, and displays the data on the CONSULT-II screen (Malfunction record diagnosis)

Malfunction description	CONSULT-II display item	Description
Communication malfunction	COMM DATA	<ul style="list-style-type: none"> <li>● Communicating with each LCU is judged sound when the communication is normally completed and the transmitted data and received data are identically the same. In other cases, it is judged malfunctioning. If the communication is inactive, no diagnosis result is displayed.</li> </ul>
Inactive communication	NO RESPONSE	<ul style="list-style-type: none"> <li>● Communicating with each LCU is judged sound when at least one time communication is normally completed within three trials. In other cases, it is judged malfunctioning.</li> </ul>
Sleep malfunction	SLEEP	<ul style="list-style-type: none"> <li>● Check that each LCU enters sleep mode.</li> </ul>

# REVERSE INTERLOCK DOOR MIRROR SYSTEM

Malfunction description	CONSULT-II display item	Description
Communication malfunction *	PAST COMM DATA	<ul style="list-style-type: none"> <li>The records when communication signal malfunctions were continuously detected while the communication was normal are displayed. Or the records when a malfunction is detected during the past sleep mode are displayed.</li> </ul>
Inactive communication*	PAST NO RESPONSE	<ul style="list-style-type: none"> <li>The records when inactive communications were continuously detected while the communication was normal are displayed.</li> </ul>

\*: malfunctioning item record

## Operation Procedure

1. Touch "IVMS-COMM CHECK" on "SELECT TEST ITEM" screen.
2. Touch "IVMS-COMM DIAGNOSIS" on "SELECT DIAG ITEM" screen.
3. Touch "START" on "IVMS-COMM DIAGNOSIS" screen to start the diagnosis.
4. After the diagnosis is completed, the malfunctioning system is displayed.
5. When the malfunctioning items are displayed, touch "PRINT" to record.
6. Touch "ERASE".
7. Carry out the communication inspection again to check that any malfunctioning item is displayed.
8. Check the displayed items.

## Wake-Up Diagnosis

- The wake-up diagnosis is carried out when BCM detects the wake-up signal from each local unit (LCU). When the switch shown on the screen is operated as instructed, each local control unit(LCU) outputs the wake-up signal. If BCM cannot detect a wake-up signal, it is judged malfunctioning. The malfunctioning local control unit(LCU) is displayed on the screen.

## Operation Procedure

1. Touch "IVMS-COMM CHECK" on "SELECT TEST ITEM" screen.
2. Touch "WAKE-UP DIAGNOSIS" on "SELECT DIAG ITEM" screen.
3. Touch "START" on "WAKE-UP DIAGNOSIS" screen to start the diagnosis.
4. Touch "NEXT" to select the local control unit (LCU) to be diagnosed.
5. Check that any malfunction is displayed. If necessary, touch "PRINT" to record.
6. Carry out the inspection to the malfunctioning item.

## Trouble Diagnosis Chart

Malfunctioning item	Display unit	CONSULT-II IVMS communication diagnosis content	Self-diagnosis trouble code No.	Malfunctioning system and reference
COMM DATA	One LCU is displayed.	POWER WINDOW C/U-DR "COMM DATA"	24	Replace the displayed LCU.
		DOOR MIRROR C/U-RH "COMM DATA"	27	
		DOOR MIRROR C/U-LH "COMM DATA"	37	
		POWER SEAT C/U-DR "COMM DATA"	47	
	Multiple LCUs are displayed	BCM "COMM FAIL1" ,"COMM FAIL2"	Displays in order of 24→27→37→47 and cycles from 24.	Communication system A: Refer to <a href="#">GW-94, "COMMUNICATION SYSTEM A"</a>

# REVERSE INTERLOCK DOOR MIRROR SYSTEM

Malfunctioning item	Display unit	CONSULT-II IVMS communication diagnosis content	Self-diagnosis trouble code No.	Malfunctioning system and reference
NO RESPONSE	One LCU is displayed.	POWER WINDOW C/U-DR "NO RESPONSE"	25	Communication system B: Refer to <a href="#">GW-95, "COMMUNICATION SYSTEM B"</a>
		DOOR MIRROR C/U-RH "NO RESPONSE"	28	
		DOOR MIRROR C/U-LH "NO RESPONSE"	38	
		POWER SEAT C/U-DR "NO RESPONSE"	48	
	Multiple LCUs are displayed	BCM/HARNESS	Displays in order of 25→28→38→48 and cycles from 25.	Communication system C: Refer to <a href="#">GW-95, "COMMUNICATION SYSTEM C"</a>
SLEEP malfunction	One LCU is displayed.	POWER WINDOW C/U-DR "SLEEP"	No self-diagnosis function	Replace the displayed LCU.
		DOOR MIRROR C/U-RH "SLEEP"		
		DOOR MIRROR C/U-LH "SLEEP"		
		POWER SEAT C/U-DR "SLEEP"		
	Multiple LCUs are displayed	All the above control units are displayed.	No self-diagnosis function	Communication system A: Refer to <a href="#">GW-94, "COMMUNICATION SYSTEM A"</a>

## NOTE:

- For a specific local control unit (LCU), either "PAST COMM DATA" or "PAST NO RESPONSE" may be displayed instead of the above results. The data record, causes this, so erase the records.  
(The display only shows the incident records, they are not malfunctions caused during the diagnosis. One possible cause is that an intermittent incident occurred.)
- Follow the steps below to erase the memory.  
Carry out either disconnect BCM battery power supply or erase memory with CONSULT-II.
- With the battery connected, if the local control unit (LCU) connector is disconnected and left for approximately 1 minute, BCM stores "NO RESPONSE" record.

## COMMUNICATION SYSTEM A

### 1. BCM INSPECTION

Replace BCM with a known-good one, and carry out the communication diagnosis. Refer to [GW-92, "IVMS Communication Diagnosis"](#).

OK or NG

- OK >> Replace BCM  
NG >> GO TO 2.

### 2. LCU INSPECTION

- Replace with the previously installed BCM.
- Replace LCU with a known-good one, and carry out the communication diagnosis. Refer to [GW-92, "IVMS Communication Diagnosis"](#).

OK or NG

- OK >> Replace LCU  
NG >> Perform the following.
- Repair or replace communication harness between LCU and BCM.
  - Replace with the previously installed LCU.

# REVERSE INTERLOCK DOOR MIRROR SYSTEM

## COMMUNICATION SYSTEM B

### 1. HARNESS CONNECTOR INSPECTION

Check the terminals (at the control unit and harness) on the malfunctioning LCU for disconnection, bend, loose connection, and other malfunctions.

OK or NG

OK >> GO TO 2.

NG >> Repair the terminals and connectors.

### 2. LCU INSPECTION

Replace the malfunctioning LCU with a known-good one, and carry out the communication diagnosis. Refer to [GW-92, "IVMS Communication Diagnosis"](#).

OK or NG

OK >> Replace LCU

NG >> Perform the following.

- Repair or replace communication harness between LCU and BCM.
- Replace with the previously installed LCU.

## COMMUNICATION SYSTEM C

### 1. HARNESS CONNECTOR INSPECTION

Check the terminals (at the control unit and harness) on BCM and LCU for disconnection, bend, loose connection, and other malfunctions.

OK or NG

OK >> GO TO 2.

NG >> Repair the terminals and connectors.

### 2. BCM INSPECTION

Replace the malfunctioning BCM with a known-good one, and carry out the communication diagnosis. Refer to [GW-92, "IVMS Communication Diagnosis"](#).

OK or NG

OK >> Replace BCM

NG >> Perform the following.

- Repair the communication harness between LCU and BCM control.
- Replace with the previously installed BCM.

## SELF-DIAGNOSIS RESULTS

### Operation Procedure

1. Touch "AUTO DRIVE POSITIONER" on "SELECT TEST ITEM" screen.
2. Touch "SELF-DIAG RESULTS" on "SELECT DIAG MODE" screen.
3. Touch "START" on "SELF-DIAG RESULTS" screen.
4. The seat and steering wheel automatically move, and the self-diagnosis for the seat, steering wheel and door mirror start (door mirror does not operate).
5. Within 15 seconds after the self-diagnosis for the seat, steering wheel and door mirror are completed, drive the vehicle at a speed of 7 km/h(4 MPH) or higher for the vehicle speed sensor self-diagnosis.
6. After the diagnosis is completed, the malfunctioning system is displayed.
7. When the malfunctioning items are displayed, touch "COPY" to record.
8. Touch "ERASE".
9. Perform self-diagnosis results again to check that any malfunctioning item is displayed.
10. Check the displayed items.

# REVERSE INTERLOCK DOOR MIRROR SYSTEM

## Display Item List

Malfunctioning system	Malfunction detecting condition
SEAT SLIDE	While the sliding motor moves the seat backward for 2.5 seconds, and then forward for 2.5 seconds, when the sliding sensor pulse change less than 2 times.
SEAT RECLINING	While the reclining motor moves the seat forward for 2.5 seconds, and then backward for 2.5 seconds, when the reclining sensor pulse change less than 2 times.
SEAT LIFTER-FR	While the lifter motor (front end) moves the seat downward for 2.5 seconds, and then upward for 2.5 seconds, when the lifter sensor (front end) pulse change less than 2 times.
SEAT LIFTER-RR	While the lifter motor (rear end) moves the seat downward for 2.5 seconds, and then upward for 2.5 seconds, when the lifter sensor (rear end) pulse change less than 2 times.
STEERING TILT	While the tilt motor moves the steering wheel upward for 1 second, and then downward for 1 second, when the tilt sensor output voltage is 0.2V or less.
STEERING TELESCO	While the telescoping motor moves the steering wheel forward for 1 second, and then backward for 1 second, if the telescoping sensor output voltage is 0.2V or less.
DOOR MIRROR - LH · UP - DOWN	While LH door mirror sensor detects 0.2V or lower, or 4.5V or higher, for 0.5 seconds or more.
DOOR MIRROR - LH · L - R	
DOOR MIRROR - RH · UP - DOWN	While RH door mirror sensor detects 0.2V or lower, or 4.5V or higher, for 0.5 seconds or more.
DOOR MIRROR - RH · L - R	
VEHICLE SPEED SENSOR	While the vehicle speed is less than 7 km/h (4 MPH) for 15 seconds after the diagnosis for the seat and steering wheel is completed.

## DATA MONITOR

### Display Item List

Monitor item [OPERATION or UNIT]	Contents
SLIDE SW-FR "ON/OFF"	ON / OFF status judged from the sliding switch (FR) signal is displayed.
SLIDE SW-RR "ON/OFF"	ON / OFF status judged from the sliding switch (RR) signal is displayed.
RECLIN SW-FR "ON/OFF"	ON / OFF status judged from the reclining switch (FR) signal is displayed.
RECLIN SW-RR "ON/OFF"	ON / OFF status judged from the reclining switch (RR) signal is displayed.
LIFT FR SW-UP "ON/OFF"	ON / OFF status judged from the FR lifter switch (UP) signal is displayed.
LIFT FR SW-DN "ON/OFF"	ON / OFF status judged from the FR lifter switch (DOWN) signal is displayed.
LIFT RR SW-UP "ON/OFF"	ON / OFF status judged from the RR lifter switch (UP) signal is displayed.
LIFT RR SW-DN "ON/OFF"	ON / OFF status judged from the RR lifter switch (DOWN) signal is displayed.
MIR CON SW-UP "ON/OFF"	ON / OFF status judged from the door mirror remote control switch (UP) signal is displayed.
MIR CON SW-DN "ON/OFF"	ON / OFF status judged from the door mirror remote control switch (DOWN) signal is displayed.
MIR CON SW-RH "ON/OFF"	ON / OFF status judged from the door mirror remote control switch (RIGHT) signal is displayed.
MIR CON SW-LH "ON/OFF"	ON / OFF status judged from the door mirror remote control switch (LEFT) signal is displayed.
MIR CHNG SW-R "ON/OFF"	ON / OFF status judged from the door mirror remote control switch (switching to RIGHT) signal is displayed.



# REVERSE INTERLOCK DOOR MIRROR SYSTEM

Monitor item [OPERATION or UNIT]	Contents
MIR CHNG SW-L "ON/OFF"	ON/ OFF status judged from the door mirror remote control switch (switching to LEFT) signal is displayed.
SET SW "ON/OFF"	ON / OFF status judged from the setting switch signal is displayed.
TELESCO SW-FR "ON/OFF"	ON / OFF status judged from the telescoping switch (FR) signal is displayed.
TELESCO SW-RR "ON/OFF"	ON / OFF status judged from the telescoping switch (RR) signal is displayed.
TILT SW-UP "ON/OFF"	ON / OFF status judged from the tilt switch (UP) signal is displayed.
TILT SW-DOWN "ON/OFF"	ON / OFF status judged from the tilt switch (DOWN) signal is displayed.
MEMORY SW1 "ON/OFF"	ON / OFF status judged from the seat memory switch 1 signal is displayed.
MEMORY SW2 "ON/OFF"	ON / OFF status judged from the seat memory switch 2 signal is displayed.
CANCEL SW "ON/OFF"	Setting status is displayed with the display unit: "Active (ON) / inactive (OFF) "
DOOR SW DR "ON/OFF"	Door open (ON) / door closed (OFF) status judged from the driver door switch is displayed.
VHCL SPEED SE "<7km/ >7km"	The present vehicle speed (less than 7 km/h (4 MPH), or 7 km/h (4MPH) or higher) is displayed.
DETENT SW "ON/OFF"	The selector lever position "P position (ON) / other than P position (OFF)" judged from the detent switch signal is displayed.
IGN ON SW "ON/OFF"	ON / START, ACC, or OFF status judged from the ignition switch signal is displayed.
IGN ACC SW "ON/OFF"	ACC or ON / START, or OFF status judged from the ignition switch signal is displayed.
IGN START SW "ON/OFF"	START, ON / ACC, or OFF status judged from the ignition switch signal is displayed.
IGN KEY SW "ON/OFF"	Key inserted (ON) / key removed (OFF) status judged from the key detection switch is displayed.
R POSITION SW "ON/OFF"	R position (ON) / Other than R position OFF of shift position signal from back-up lamp relay is displayed.
TILT SEN "V"	The tilt position (voltage) judged from the tilt sensor signal is displayed.
TELESCO SEN "V"	The telescoping position (voltage) judged from the telescoping sensor signal is displayed.
MIR/SE RH R-L "ON/OFF"	ON (normal value ) / OFF (abnormal value) *of voltage value judged from RH door mirror sensor output voltage (LH/RH) is displayed.
MIR/SE RH U-D "ON/OFF"	ON (normal value) / OFF (abnormal value) *of voltage value judged from RH door mirror sensor output voltage (UP/ DOWN) is displayed.
MIR/SE LH R-L "ON/OFF"	ON (normal value) / OFF (abnormal value) *of voltage value judged from LH door mirror sensor output voltage (LH / RH) is displayed.
MIR/SE LH U-D "ON/OFF"	ON (normal value) / OFF (abnormal value) *of voltage value judged from LH door mirror sensor output voltage (UP/ DOWN) is displayed.
Voltage "V"	Displays measured values by voltage probe.
Frequency "ms,Hz,%"	Displays value measured with pulse probe.

\*: Abnormal value indicates that the sensor output voltage is 0.2V or lower, or 4.5V or higher.

# REVERSE INTERLOCK DOOR MIRROR SYSTEM

## ACTIVE TEST

### Display Item List

Test item	Description
TILT MOTOR	The tilt motor is activated by receiving the drive signal.
TELESCO MOTOR	The telescoping motor is activated by receiving the drive signal.
SEAT SLIDE	The sliding motor is activated by receiving the drive signal.
SEAT RECLINING	The reclining motor is activated by receiving the drive signal.
SEAT LIFTER FR	The front end lifter motor is activated by receiving the drive signal.
SEAT LIFTER RR	The rear end lifter motor is activated by receiving the drive signal.
MEMORY SW INDCTR	The memory switch indicator is lit by receiving the drive signal.
MIRROR MOTOR RH	The passenger side door mirror motor moves the mirror UP/DOWN and LEFT/RIGHT by receiving the drive signal.
MIRROR MOTOR LH	The driver side door mirror motor moves the mirror UP/DOWN and LEFT/RIGHT by receiving the drive signal.

# REVERSE INTERLOCK DOOR MIRROR SYSTEM

EIS008GJ

## On Board Diagnosis

- BCM can check each local unit (LCU), switches, loads, and malfunctions in communication with the self-diagnosis.

### DIAGNOSIS ITEM

Diagnosis item	Description
Communication diagnosis	● It can check the communication line between BCM and each LCU, and also each LCU, for a communication error and malfunction.
Switch monitor	● It can check the switch systems which send data to BCM and each LCU for a malfunction.
Self-diagnosis for auto drive positioner	● Diagnoses malfunctions in each motor and sensor in the electrical load parts of the driver power seat system (sliding, reclining, and lifter [front/rear]), of the steering wheel system (tilt, telescoping), and of door mirror.

### COMMUNICATION DIAGNOSIS

- Check the communication between BCM and each local control unit (LCU).

#### Operation Procedure

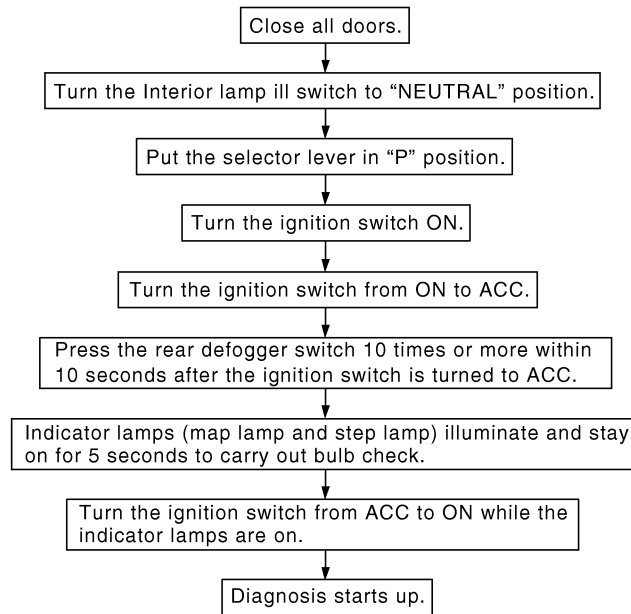
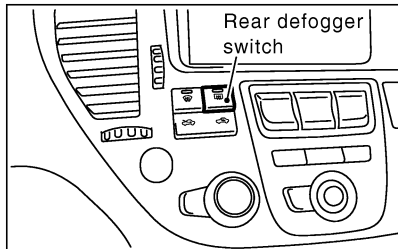
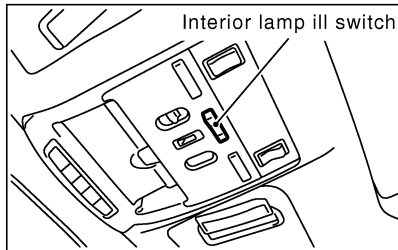

PIIA3358E

#### Diagnosis Result Display

- The indicator lamps (the map lamp and step lamp) turn ON (illuminate) for 2 seconds and OFF (go off) for 2 seconds to indicate that the diagnosis has started, then indicate the diagnosis trouble code.
- To indicate the self-diagnosis trouble code, the indicator lamps illuminate or flash.
- At first, the lamps indicate the second place by ON/OFF with 0.5 second-interval, then OFF for 1.5 seconds. Next, they indicate the first place by ON/OFF with 0.5 second interval.
- If there are multiple malfunctioning parts, the lamps indicate them in sequence from the smallest diagnosis trouble code.
- The diagnosis results repeat until the diagnosis is cancelled.
- If a malfunction is indicated, carry out the communication diagnosis again to check that the same diagnosis trouble code is indicated.

# REVERSE INTERLOCK DOOR MIRROR SYSTEM

## Diagnosis Trouble Code Indication Example

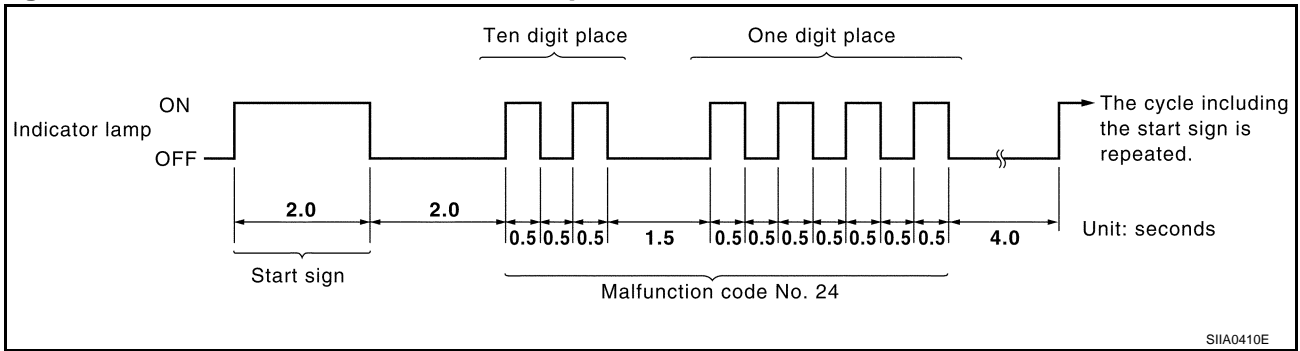

## Trouble Diagnosis Chart

Malfunctioning item	Display unit	CONSULT-II IVMS communication diagnosis content	Self-diagnosis trouble code No.	Malfunctioning system and reference
COMM DATA	One LCU is displayed.	POWER WINDOW C/U-DR "COMM DATA"	24	Replace the displayed LCU.
		DOOR MIRROR C/U-RH "COMM DATA"	27	
		DOOR MIRROR C/U-LH "COMM DATA"	37	
		POWER SEAT C/U-DR "COMM DATA"	47	
	Multiple LCUs are displayed	BCM "COMM FAIL1", "COMM FAIL2"	Displays in order of 24 →27→37→47 and cycles from 24.	Communication system A: Refer to <a href="#">GW-94. "COMMUNICATION SYSTEM A"</a>
NO RESPONSE	One LCU is displayed.	POWER WINDOW C/U-DR "NO RESPONSE"	25	Communication system B: Refer to <a href="#">GW-95. "COMMUNICATION SYSTEM B"</a>
		DOOR MIRROR C/U-RH "NO RESPONSE"	28	
		DOOR MIRROR C/U-LH "NO RESPONSE"	38	
		POWER SEAT C/U-DR "NO RESPONSE"	48	
	Multiple LCUs are displayed	BCM/HARNESS	Displays in order of 25→28→38→48 and cycles from 25.	Communication system C: Refer to <a href="#">GW-95. "COMMUNICATION SYSTEM C"</a>
SLEEP malfunction	One LCU is displayed.	POWER WINDOW C/U-DR "SLEEP"	No self-diagnosis function	Replace the displayed LCU.
		DOOR MIRROR C/U-RH "SLEEP"		
		DOOR MIRROR C/U-LH "SLEEP"		
		POWER SEAT C/U-DR "SLEEP"		
	Multiple LCUs are displayed	All the above control units are displayed.	No self-diagnosis function	Communication system A: Refer to <a href="#">GW-94. "COMMUNICATION SYSTEM A"</a>

### NOTE:

- For a specific local control unit (LCU), either "PAST COMM DATA" or "PAST NO RESPONSE" may be displayed instead of the above results. This is caused by the data record, so erase the records.  
(The display only shows the incident records, they are not malfunctions caused during the diagnosis. One possible cause is that an irreproducible incident occurred.)
- Follow the steps below to erase the memory.

# REVERSE INTERLOCK DOOR MIRROR SYSTEM

Carry out either disconnect BCM battery power supply or erase memory with CONSULT-II.

- With the battery connected, if the local control unit (LCU) connector is disconnected and left for approximately 1 minute, BCM stores "NO RESPONSE" record.

A

## Cancel of Communication Diagnosis

If one of the following conditions are satisfied, the communication diagnosis is cancelled.

- When the ignition switch is turned OFF.
- The vehicle speed becomes 7 km/h (4 MPH) or higher.
- Ten minutes have passed since the diagnosis result indication start without no diagnosis cancel operation.

B

C

## COMMUNICATION SYSTEM A

### 1. BCM INSPECTION

D

Replace BCM with a known-good one, and carry out the communication diagnosis. Refer to [GW-99, "COMMUNICATION DIAGNOSIS"](#).

E

OK or NG

- OK >> Replace BCM
- NG >> GO TO 2.

F

### 2. LCU INSPECTION

1. Replace with the previously installed BCM.
2. Replace LCU with a known-good one, and carry out the communication diagnosis. Refer to [GW-99, "COMMUNICATION DIAGNOSIS"](#).

G

H

OK or NG

- OK >> Replace LCU
- NG >> Perform the following.
  - Repair the communication harness between LCU and BCM.
  - Replace with the previously installed LCU.

GW

## COMMUNICATION SYSTEM B

J

### 1. HARNESS CONNECTOR INSPECTION

Check the terminals (at the control unit and harness) on the malfunctioning LCU for disconnection, bend, poor connection and other malfunctions.

K

OK or NG

- OK >> GO TO 2.
- NG >> Repair the terminals and connectors.

L

### 2. LCU INSPECTION

M

Replace the malfunctioning LCU with a known-good one, and carry out the communication diagnosis. Refer to [GW-99, "COMMUNICATION DIAGNOSIS"](#).

OK or NG

- OK >> Replace LCU
- NG >> Perform the following.
  - Repair the communication harness between LCU and BCM.
  - Replace with the previously installed LCU.

# REVERSE INTERLOCK DOOR MIRROR SYSTEM

## COMMUNICATION SYSTEM C

### 1. HARNESS CONNECTOR INSPECTION

Check the terminals (at the control unit and harness) on BCM and LCU for disconnection, bend, poor connection, and other malfunctions.

OK or NG

- OK >> GO TO 2.
- NG >> Repair the terminals and connectors.

### 2. BCM INSPECTION

Replace the malfunctioning BCM with a known-good one, and carry out the communication diagnosis. Refer to [GW-99, "COMMUNICATION DIAGNOSIS"](#).

OK or NG

- OK >> Replace BCM
- NG >> Perform the following.
  - Repair the communication harness between LCU and BCM control.
  - Replace with the previously installed BCM.

### SWITCH MONITOR

- Carry out the diagnosis for the switch system input to each control unit.

#### Operation Procedure

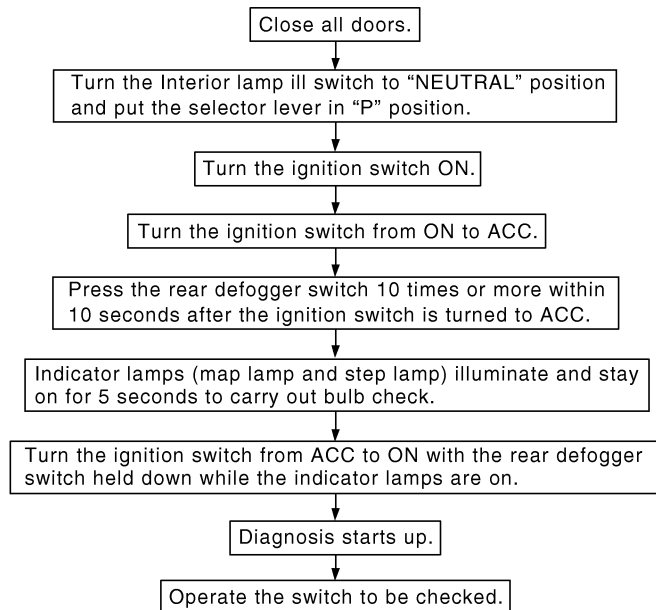
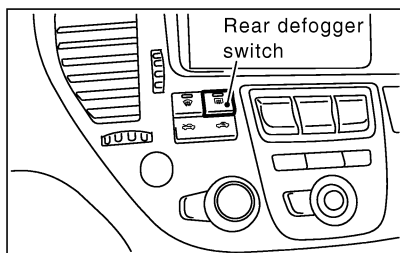
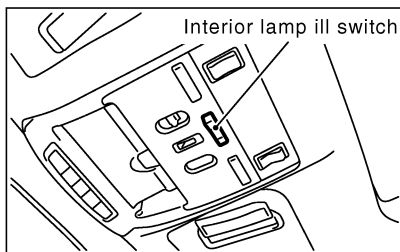

PIIA3356E

#### Diagnosis Result Display

- Detects the status change (switch ON/OFF operation) of the switch to be checked, and turns on/off the indicator lamps (the map lamp and step lamp). Also sounds the buzzer (the key remainder and light remainder) for 0.5 seconds.

# REVERSE INTERLOCK DOOR MIRROR SYSTEM

- If a malfunction is detected, no indicator lamp and buzzer react.

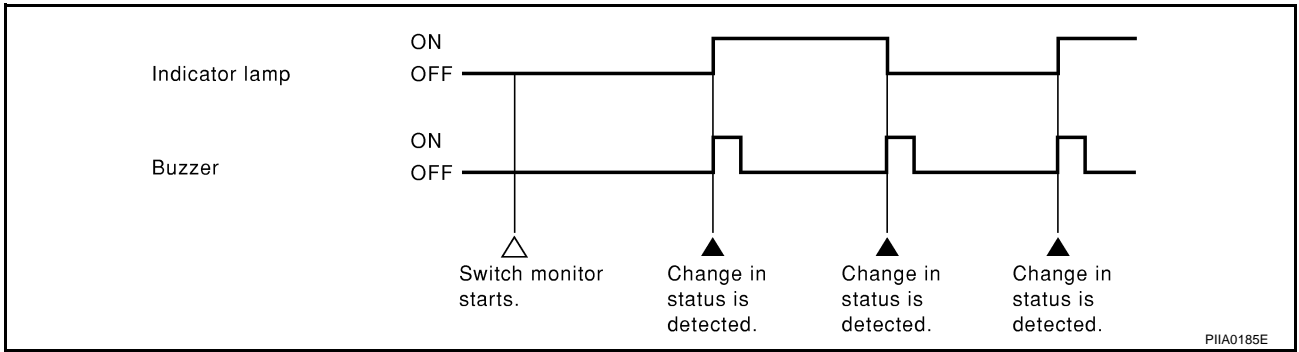

## Diagnosis Item

- The status of the switch (except the ignition switch, interior lamp switch, and map lamp switch) input to each control unit can be monitored.

Control unit	Item
BCM	Detent switch
	Steering wheel position switch (telescoping switch and tilt switch)
	Seat memory switch (memory switch 1, memory switch 2, and setting switch).
	Driver door switch
	Door mirror remote control switch

## Cancel of Switch Monitor

If one of the following conditions are satisfied, the switch monitor is cancelled.

- When the ignition switch is turned OFF.
- The vehicle speed becomes 7 km/h (4 MPH) or higher.

A  
B  
C  
D  
E  
F  
G  
H  
J  
K  
L  
M

GW

# REVERSE INTERLOCK DOOR MIRROR SYSTEM

## ON BOARD DIAGNOSIS FOR AUTOMATIC DRIVE POSITIONER

- Check the operations of the auto drive positioner system.

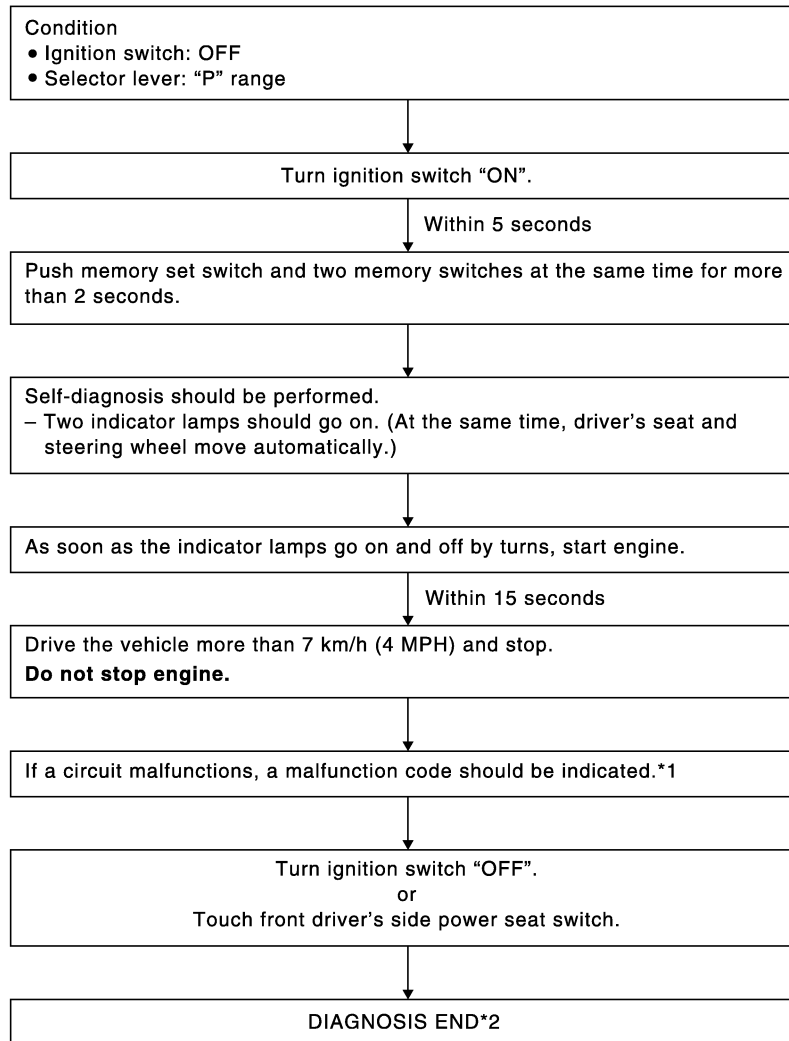

PIIA4472E

\*1:If no malfunction is indicated, On board Diagnosis will end after the vehicle speed sensor diagnosis is performed.









\*2:Diagnosis ends after self-diagnostic results have indicated for 10 minutes if left unattended.

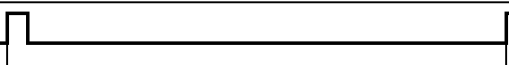
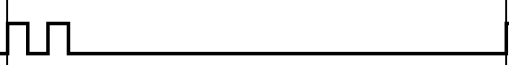

# REVERSE INTERLOCK DOOR MIRROR SYSTEM

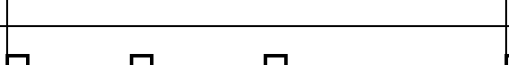
## Diagnosis Result Display

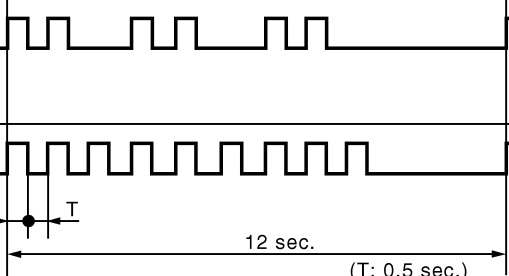
- The malfunctioning items are indicated by how many times LEDs on the seat memory switches 1 and 2 flash simultaneously.

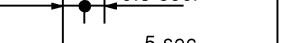
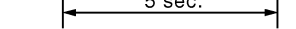
Code No.	Detected items	Indication of seat memory switches 1 and 2	Explanation
1	Seat sliding	IND1, IND2 	While the seat motors are moving for 2.5 seconds, if the number of seat sliding/reclining/lifting sensor pulses changes 2 times or less, the seat device is determined to be malfunctioning.
2	Seat reclining	IND1, IND2 	
3	Seat lifting front	IND1, IND2 	
4	Seat lifting rear	IND1, IND2 	
5	Steering telescopic	IND1, IND2 	While the steering motors are moving, if the steering sensor output changes 0.2 volts or less, the steering device is determined to be malfunctioning.
6	Steering tilt	IND1, IND2 	
7	Door mirrors (upper and lower)	IND1, IND2 	When output voltage of either LH or RH door mirror sensor continues at less than 0.2V or more than 4.5V for 0.5 seconds or more, the door mirror is determined to be malfunctioning.
8	Door mirrors (LH and RH)	IND1, IND2 	When output voltage of either LH or RH door mirror sensor continues at less than 0.2V or more than 4.5V for 0.5 seconds or more, the door mirror is determined to be malfunctioning.
9	Vehicle speed sensor circuit	IND1, IND2 	If the vehicle speed sensor output of less than 7 km/h (4 MPH) is detected, the vehicle speed sensor is determined to be malfunctioning.
-	No malfunction in the above items	SW1 IND  SW2 IND  0.5 sec.  5 sec. 	—

PIIA0190E

- If the vehicle speed is less than 7 km/h (4 MPH) for 15 seconds after the diagnosis for the seat and steering wheel systems were completed, the vehicle speed signal is judged malfunctioning.
- If LH door mirror is malfunctioning, only indicator lamp on the memory switch 1 flashes, and if RH door mirror is malfunctioning, only indicator lamp on the memory switch 2 flashes.
- When all the diagnosis are finished normally, the indicator lamps on the memory switches 1 and 2 go off after the vehicle speed signal diagnosis.
- If there are multiple malfunctioning parts, the lamps indicate them in sequence from the smallest diagnosis trouble code.
- The diagnosis results repeat until the diagnosis mode is cancelled.

# REVERSE INTERLOCK DOOR MIRROR SYSTEM

## Symptom Chart

EIS008GK

Symptom	Diagnosis / Service procedure	Reference page
Reverse interlock door mirror system does not operate at all.	1. Door mirror remote control switch (changeover switch) circuit inspection.	<a href="#">GW-106</a>
	2. Back-up input signal circuit inspection in R position.	<a href="#">GW-108</a>
	3. Replace BCM.	—
<ul style="list-style-type: none"> <li>During the reverse interlock door mirror system operation, either LH or RH door mirror face does not reproduce the stored angle.</li> <li>After the reverse interlock door mirror system operation, the door mirror face returns to wrong position (not to the original position).</li> </ul>	1. Mirror sensors circuit inspection.	<a href="#">GW-112</a>
	2. Carry out the communication inspection again.	—
The mirror face position with the reverse gear engaged cannot be memorized.	1. Seat memory switch circuit inspection.	<a href="#">SE-76</a>
	2. Door mirror remote control switch (changeover switch) system inspection.	<a href="#">GW-106</a>
	3. Door mirror remote control switch (mirror switch) system inspection.	<a href="#">GW-109</a>
	4. Back-up input signal control inspection R position inspection.	<a href="#">GW-108</a>
	5. Mirror motors circuit inspection.	<a href="#">GW-110</a>
	6. Mirror sensors circuit inspection.	<a href="#">GW-112</a>
	7. Replace BCM.	—

## Door Mirror Remote Control Switch (Changeover Switch) Circuit Inspection EIS008GL

### 1. FUNCTION INSPECTION

#### With CONSULT-II

Check the operation on "MIR CHNG SW-R" or "MIR CHNG SW-L" in the DATA MONITOR.

DATA MONITOR	
MONITOR	
MIR CHNG SW-R	OFF
MIR CHNG SW-L	OFF

PIIB0343E

#### Without CONSULT-II

Carry out the switch monitor in the self-diagnostic function. Refer to [GW-102, "SWITCH MONITOR"](#).

OK or NG

- OK >> Door mirror remote control switch (changeover switch) circuit is OK.
- NG >> GO TO 2.

# REVERSE INTERLOCK DOOR MIRROR SYSTEM

## 2. DOOR MIRROR REMOTE CONTROL SWITCH (CHANGEOVER SWITCH) INSPECTION

1. Turn ignition switch OFF.
2. Disconnect door mirror remote control switch connector.
3. Check continuity between door mirror remote control switch terminal 5 (RH), 6 (LH) and 7.

**Changeover switch RIGHT position**

**5 – 7 :Continuity should exist.**

**Changeover switch LEFT position**

**6 – 7 :Continuity should exist.**

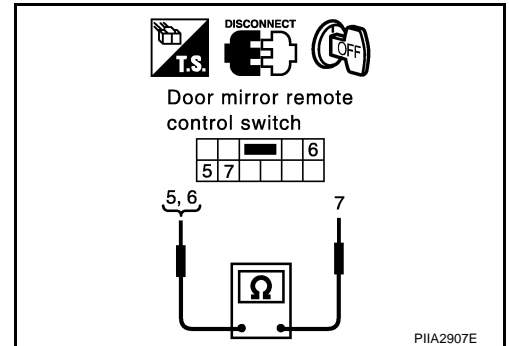

OK or NG

OK >> GO TO 3.

NG >> Replace the door mirror remote control switch.

## 3. HARNESS CONTINUITY INSPECTION

1. Disconnect BCM connector.
2. Check continuity between BCM connector M4 terminals 21, 24 and door mirror remote control switch connector M19 terminals 5, 6.

**21 (SB) – 5 (SB) :Continuity should exist.**

**24 (BR/Y) – 6 (BR/Y) :Continuity should exist.**

3. Check continuity between BCM connector M4 terminals 21, 24 and ground.

**21 (SB) – Ground :Continuity should not exist.**

**24 (BR/Y) – Ground :Continuity should not exist.**

OK or NG

OK >> GO TO 4.

NG >> Repair or replace harness.

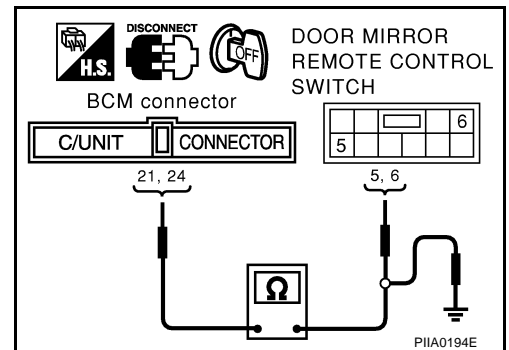

## 4. GROUND CIRCUIT INSPECTION OF DOOR MIRROR REMOTE CONTROL SWITCH

Check continuity between the door mirror remote control switch connector M19 terminal 7 and ground.

**7 (B) – Ground :Continuity should exist.**

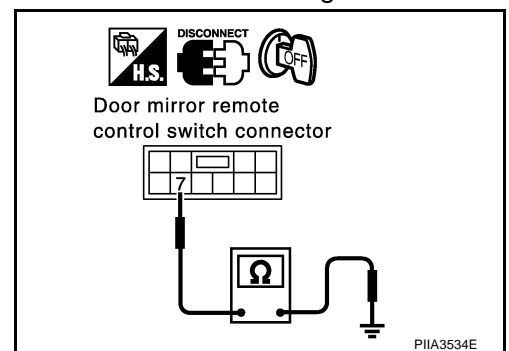

OK or NG

OK >> Check harness connection.

NG >> Repair or replace harness.

# REVERSE INTERLOCK DOOR MIRROR SYSTEM

EIS008GM

## Back-up Input Signal Circuit Inspection In R Position

### 1. CHECK THE SYMPTOM

Check that other systems using the reverse signal are under normal operation.

**Whether back-up lamp lights is checked.**

OK or NG

OK >> GO TO 2.

NG >> Refer to [AT-259, "Vehicle Does Not Creep Backward In "R" Position"](#) .

### 2. CHECK BACK-UP SIGNAL

 **With CONSULT-II**

Check the operation on "R POSITION SW" in the DATE MONITOR.

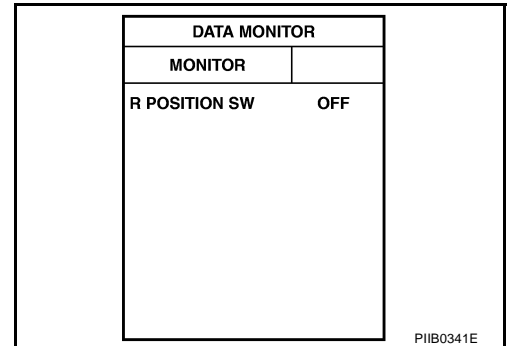

 **Without CONSULT-II**

Carry out the switch monitor in the self-diagnostic function. Refer to [GW-102, "SWITCH MONITOR"](#) .

OK or NG

OK >> Back-up input signal circuit is OK.

NG >> GO TO 3.

### 3. CHECK HARNESS CONTINUITY

1. Turn ignition switch OFF.
2. Disconnect BCM and back-up lamp relay connector.
3. Check continuity between BCM connector B4 terminal 141 and back-up lamp relay connector E2-2 terminal 3.

**141 (R/B) – 3 (R/B) :Continuity should exist.**

4. Check continuity between BCM connector B4 terminal 141 and ground.

**141 (R/B) – Ground :Continuity should not exist.**

OK or NG

OK >> Replace BCM.

NG >> Repair or replace harness.

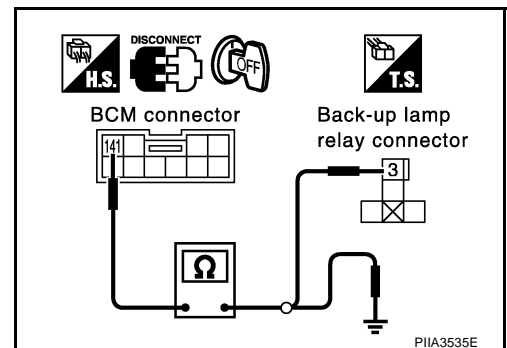

# REVERSE INTERLOCK DOOR MIRROR SYSTEM

## Door Mirror Remote Control Switch (Mirror Switch) Circuit Inspection

EIS008GN

### 1. DOOR MIRROR REMOTE CONTROL SWITCH(MIRROR SWITCH) SIGNAL INSPECTION

#### With CONSULT-II

Check the operation on "MIR CON SW-UP/DN" and "MIR CON SW-RH/LH" in the DATA MONITOR.

DATA MONITOR	
MONITOR	
MIR CON SW-UP	OFF
MIR CON SW-DN	OFF
MIR CON SW-RH	OFF
MIR CON SW-LH	OFF

PIIB0344E

#### Without CONSULT-II

Carry out the switch monitor in the self-diagnostic function. Refer to [GW-102, "SWITCH MONITOR"](#).

OK or NG

- OK >> Door mirror remote control switch (mirror switch) circuit is OK.
- NG >> GO TO 2.

### 2. DOOR MIRROR REMOTE CONTROL SWITCH (MIRROR SWITCH) INSPECTION

1. Turn ignition switch OFF.
2. Disconnect door mirror remote control switch connector.
3. Check continuity between door remote control switch (mirror switch) terminals 1, 2, 3, 4 and 7.

Terminals	Condition	Continuity
3	UP operation	Yes
4	DOWN operation	
2	LEFT operation	
1	RIGHT operation	

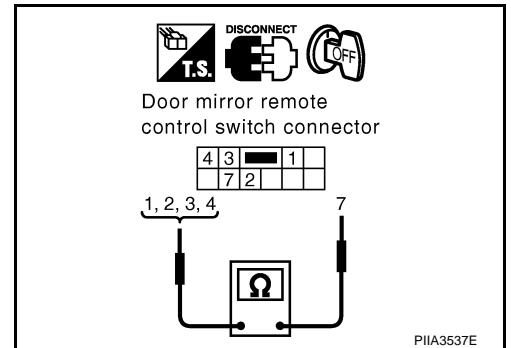

OK or NG

- OK >> GO TO 3.
- NG >> Replace the door mirror remote control switch.

### 3. GROUND CIRCUIT INSPECTION OF DOOR MIRROR REMOTE CONTROL SWITCH

Check continuity between the door mirror remote control switch connector M19 terminal 7 and ground.

**7 (B) – Ground**

**:Continuity should exist.**

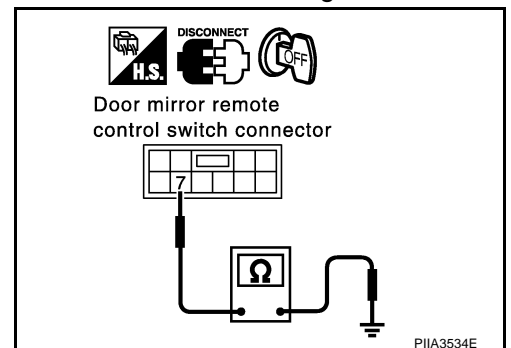

# REVERSE INTERLOCK DOOR MIRROR SYSTEM

## OK or NG

- OK >> GO TO 4.  
 NG >> Repair or replace harness

## 4. HARNESS CONTINUITY INSPECTION

1. Disconnect BCM harness connector.
2. Check continuity between BCM connector M4 terminals 25, 29, 32, 34 and door mirror remote control switch connector M19 terminals 1, 2, 3, 4.

- 25 (G/R) – 2 (G/R) :Continuity should exist.**  
**29 (LG/R) – 1 (LG/R) :Continuity should exist.**  
**32 (L/W) – 3 (L/W) :Continuity should exist.**  
**34 (P/L) – 4 (P/L) :Continuity should exist.**

3. Check continuity between BCM connector M4 terminals 25, 29, 32, 34 and ground.

- 25 (G/R) – Ground :Continuity should not exist.**  
**29 (LG/R) – Ground :Continuity should not exist.**  
**32 (L/W) – Ground :Continuity should not exist.**  
**34 (P/L) – Ground :Continuity should not exist.**

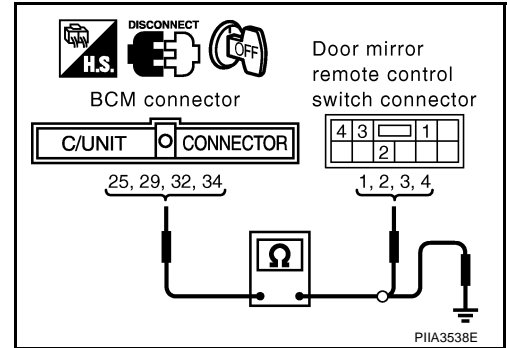

## OK or NG

- OK >> Check harness connection.  
 NG >> Repair or replace harness between BCM and door mirror remote control switch.

## Mirror Motors Circuit Inspection

EIS008GO

### 1. DOOR MIRROR FUNCTION INSPECTION

Check the following items.  
 Operation malfunction caused by a foreign object caught in door mirror face edge.

## OK or NG

- OK >> GO TO 2.  
 NG >> Repair the malfunctioning parts, and check the symptom again.

### 2. MIRROR MOTOR INSPECTION

#### With CONSULT-II

Check the operation with “MIRROR MOTOR RH ” or “MIRROR MOTOR LH ” in the ACTIVE TEST.

#### NOTE:

If CONSULT-II is not available, skip this procedure and go to the next step.

## OK or NG

- OK >> Mirror motor circuit.  
 NG >> GO TO 3.

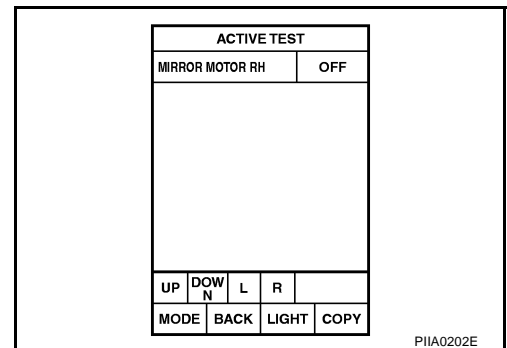

# REVERSE INTERLOCK DOOR MIRROR SYSTEM

## 3. HARNESS CONTINUITY INSPECTION

1. Turn ignition switch OFF.
2. Disconnect door mirror control unit D5 (driver side), D35 (passenger side) and door mirror connector D2 (driver side), D32 (passenger side) connectors.
3. Check continuity between door mirror control unit connector D5 (driver side), D35 (passenger side) terminals 3, 4, 9 and door mirror connector D2 (driver side), D32 (passenger side) terminals 8, 9, 11.

**3 (GY/R)(R)\* – 8 (GY/R)(R)\* :Continuity should exist.**  
**4 (BR) – 9 (BR) :Continuity should exist.**  
**9 (PU/W)(OR)\*–11 (PU/W)(OR)\* :Continuity should exist.**

4. Check continuity between door mirror control unit connector D5 (driver side), D35 (passenger side) terminals 3, 4, 9 and ground.

**3 (GY/R)(R)\* – Ground :Continuity should not exist.**  
**4 (BR) – Ground :Continuity should not exist.**  
**9 (PU/W)(OR)\* – Ground :Continuity should not exist.**

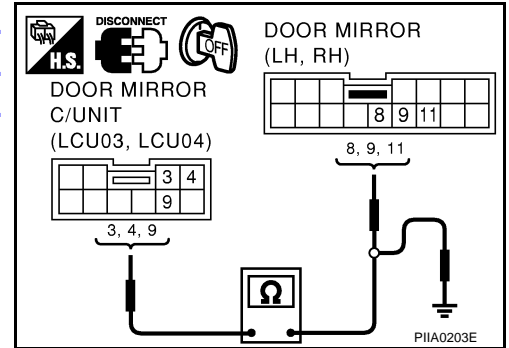

\*:Wire color for passenger side door mirror and passenger side door mirror control unit.

OK or NG

OK >> GO TO 4.

NG >> Repair or replace harness between door mirror control unit and door mirror.

## 4. MIRROR MOTOR SIGNAL INSPECTION

1. Connect door mirror control unit D5 (driver side), D35 (passenger side) and door mirror connector D2 (driver side), D32 (passenger side) connectors.
2. Turn ignition switch ON.
3. Check voltage between door mirror control unit connector D5 (driver side), D35 (passenger side) terminals 3, 4, 9 and ground.

Con- nector	Terminals (Wire color)		Condition	Voltage [V] (Approx.)
	(+)	(-)		
D5 D35	3 (GY/R) (R)*	Ground	When motor is actiated (UP)	Battery voltage
			When motor is not activated	0
	4 (BR)		When motor is actiaged (LEFT)	Battery voltage
			When motor is not activated	0
	9 (PU/W) (OR)*		When motor is activated (RIGHT) or (DOWN)	Battery voltage
			When motor is not activated	0

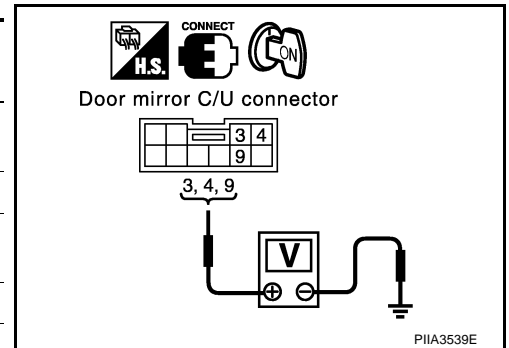

\*:Wire color for passenger side door mirror control unit

OK or NG

OK >> Replace the door mirror motor (driver side) or (passenger side).

NG >> Replace the door mirror control unit (driver side) or (passenger side).

# REVERSE INTERLOCK DOOR MIRROR SYSTEM

EIS008GP

## Mirror Sensors Circuit Inspection

### 1. DOOR MIRROR FUNCTION INSPECTION

Check the following items.

- Operation malfunction caused by a foreign object caught in door mirror face edge.
- Operation malfunction in memory control

**NOTE:**

If a door mirror face position is set to an implausible angle, the set position may not be reproduced.

OK or NG

OK >> GO TO 2.

NG >> Repair the malfunctioning parts, and check the symptom again.

### 2. MIRROR SENSOR INSPECTION

ⓑ **With CONSULT-II**

Check that "ON" is displayed on "MIR/SE RH R-L", "MIR/SE RH U-D" or "MIR/SE LH R-L", "MIR/SE LH U-D" in the DATA MONITOR.

**NOTE:**

If CONSULT-II is not available, skip this procedure and go to the next step.

OK or NG

OK >> System is OK.

NG >> GO TO 3.

DATA MONITOR	
MONITOR	
MIR/SE RH R-L	ON
MIR/SE RH U-D	ON
MIR/SE LH R-L	ON
MIR/SE LH U-D	ON

PIIB0342E

### 3. MIRROR SENSOR POWER SUPPLY INSPECTION

1. Turn ignition switch ON.
2. Check voltage between door mirror control unit connector D5 (driver side), D35 (passenger side) terminal 1 and ground.

**1 (W/L) – Ground**

**:Approx. 5V**

OK or NG

OK >> GO TO 4

NG >> Replace door mirror control unit.

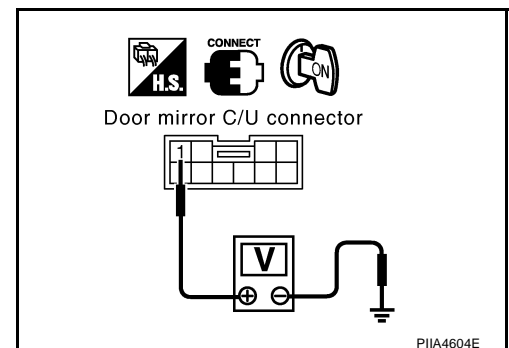



# REVERSE INTERLOCK DOOR MIRROR SYSTEM

## 4. MIRROR SENSOR GROUND CIRCUIT INSPECTION

1. Turn ignition switch OFF.
2. Check continuity between door mirror control unit connector D5 (driver side), D35 (passenger side) terminal 2 and ground.

**2 (Y) – Ground :Continuity should exist.**

OK or NG

- OK >> GO TO 5  
 NG >> Replace door mirror control unit.

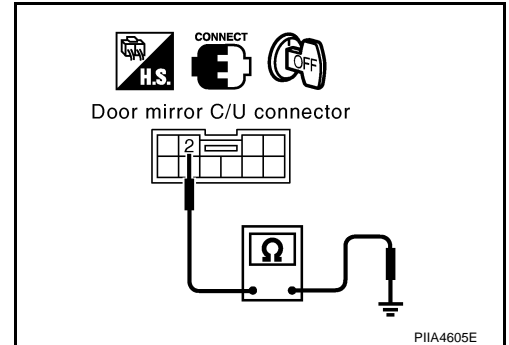

## 5. HARNESS CONTINUITY INSPECTION 1

1. Disconnect door mirror control unit connector D5 (driver side), D35 (passenger side) and door mirror connector D2 (driver side), D32 (passenger side).
2. Check continuity between door mirror control unit connector D5 (driver side), D35 (passenger side) terminal 1, 2 and door mirror connector D2 (driver side), D32 (passenger side) terminal 10, 16.

**1 (W/L) – 16 (W/L) :Continuity should exist.**  
**2 (Y) – 10 (Y) :Continuity should exist.**

OK or NG

- OK >> GO TO 6  
 NG >> Repair or replace harness.

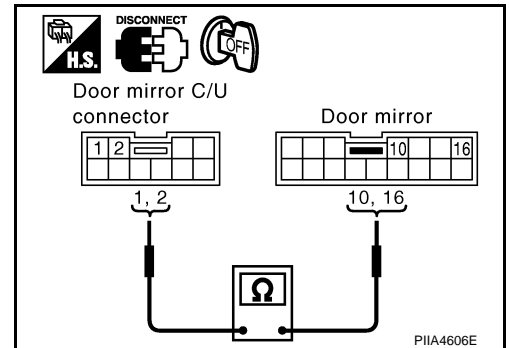

## 6. HARNESS CONTINUITY INSPECTION 2

1. Disconnect door mirror control unit connector D5 (driver side), D35 (passenger side) and door mirror connector D2 (driver side), D32 (passenger side).
2. Check continuity between door mirror control unit connector D5 (driver side), D35 (passenger side) terminals 5, 6 and door mirror connector D2 (driver side), D32 (passenger side) terminals 12, 14.

**5 (L/Y) – 14 (L/Y) :Continuity should exist.**  
**6 (G) – 12 (G) :Continuity should exist.**

3. Check continuity between door mirror control unit connector D5 (driver side), D35 (passenger side) terminals 5, 6 and ground.

**5 (L/Y) – Ground :Continuity should not exist.**  
**6 (G) – Ground :Continuity should not exist.**

OK or NG

- OK >> GO TO 7.  
 NG >> Repair or replace harness.

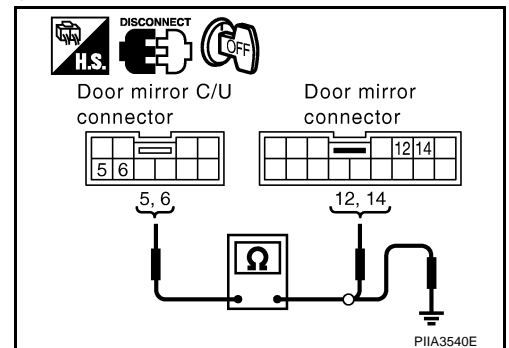

# REVERSE INTERLOCK DOOR MIRROR SYSTEM

## 7. MIRROR SENSOR SIGNAL INSPECTION

1. Connect door mirror control unit D5 (driver side), D35 (passenger side) and door mirror D2 (driver side), D32 (passenger side) connectors.
2. Turn ignition switch ON.
3. Check voltage between door mirror control unit connector D5 (driver side), D35 (passenger side) terminals 5, 6 and ground.

Con- nector	Terminals (Wire color)		Condition	Voltage [V] (Approx.)
	(+)	(-)		
D5 D35	5 (L/Y)	Ground	When motor is activated (UP/ DOWN)	Changes between 4 (close to peak) – and 0.5 (close to valley)
	6 (G)		When motor is activated (LEFT/ RIGHT)	Changes between 4 (close to right edge) – and 0.5 (close to left edge)

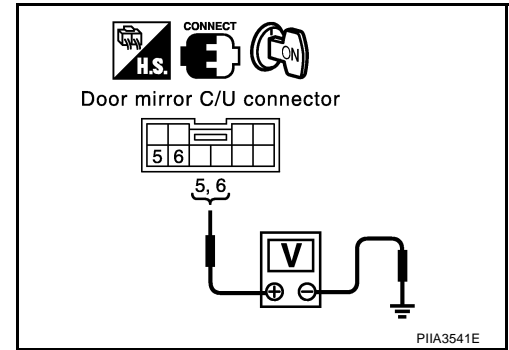

### OK or NG

- OK >> Replace the door mirror control unit.  
 NG >> Replace the door mirror.

# DOOR MIRROR

## DOOR MIRROR

PFP:96301

### Removal and Installation

EIS009LZ

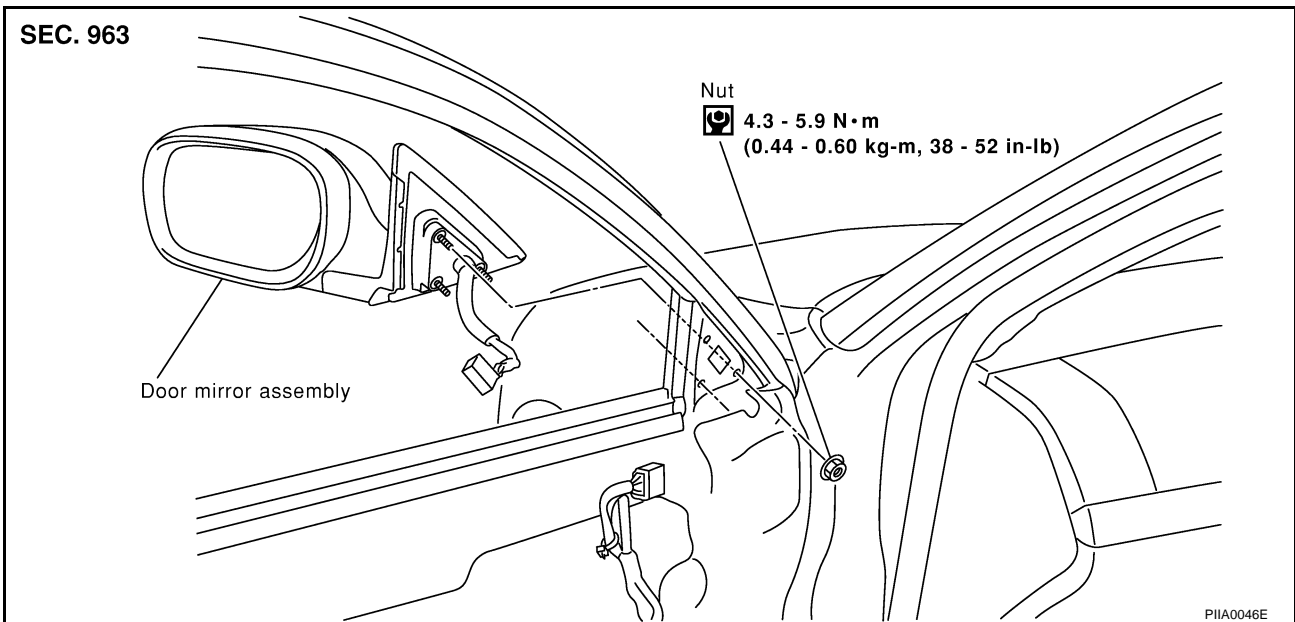

#### **CAUTION:**

Be careful not to damage the mirror bodies.

#### **REMOVAL**

1. Remove the front door finisher and door sash cover. Refer to [EI-31, "DOOR FINISHER"](#).
2. Remove the door mirror harness connector.
3. Remove the door mirror mounting nuts, and then remove the door mirror assembly.

#### **INSTALLATION**

Install in the reverse order of removal.

A

B

C

D

E

F

G

H

GW

J

K

L

M

# DOOR MIRROR

EIS009M0

## Disassembly and Assembly

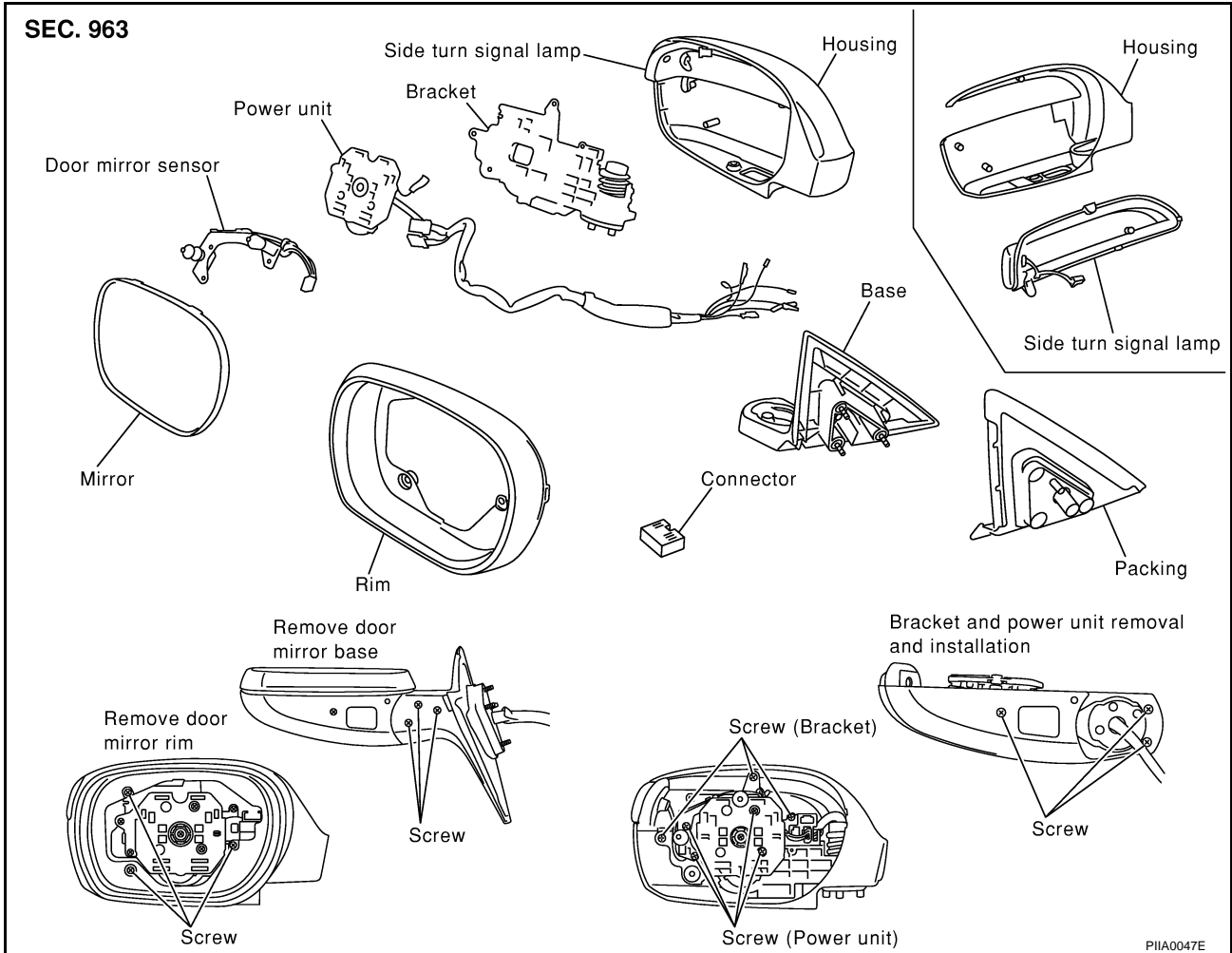

### DISASSEMBLY

1. Place the mirror body with the mirror glass facing upward.
2. Put a strip of protective tape on the mirror body.
3. As shown in the figure, insert a small slotted screwdriver wrapped with tape into the recess between the mirror face (mirror holder) and mirror holder bracket, and push up the lower pawls to remove the mirror holder lower half.

**NOTE:**

When pushing up the pawls, do not attempt to use 1 recess only, be sure to push up with both recesses. Insert screwdriver into recesses, and push up while rotating (twist) to make work easier.

4. Lightly lift up lower side of mirror surface from mirror surface, and detach pawls of upper side as if pulling out. Remove mirror surface from mirror body.

**NOTE:**

Be certain not to allow grease on sealing agent in center of mirror body assembly or back side of mirror surface (mirror holder).

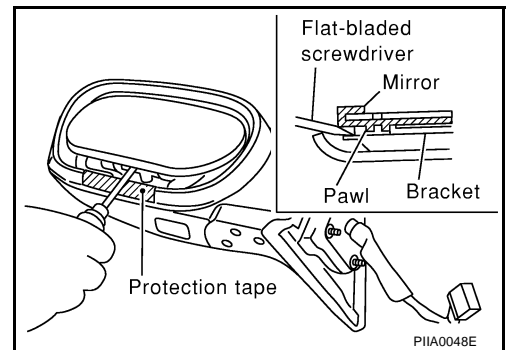

# DOOR MIRROR

## ASSEMBLY

1. Place the mirror holder bracket and mirror body assembly in a horizontal position.
2. Fit the upper tab on the mirror face onto the mirror holder bracket first, then press the lower side of the mirror face until a click sound is heard to engage the lower pawls.

### NOTE:

After installation, visually check that the lower pawls are securely engaged from the bottom of the mirror face.

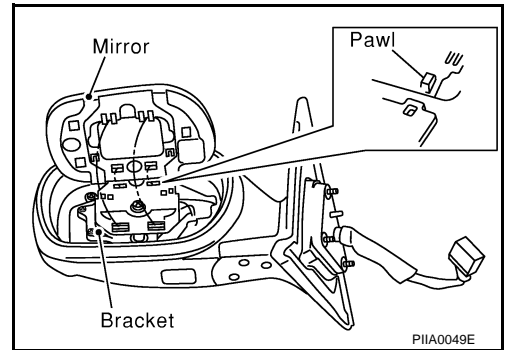

A  
B  
C  
D  
E  
F  
G  
H  
J  
K  
L  
M

GW

# DOOR MIRROR

---