

A
B
C
D
E
F
G
H
I
J
K
L
M

SECTION SE SEAT

CONTENTS

PRECAUTIONS	4	Schematic	19
Precautions for Supplemental Restraint System (SRS) "AIR BAG" and "SEAT BELT PRE-TENSIONER"	4	Wiring Diagram–AUT/DP–	21
Service Notice	4	Terminals and Reference Values for BCM	32
Precautions for Work	4	Terminals and Reference Values for Driver Seat Control Unit	33
Trouble Diagnosis Precaution	5	Work Flow	35
PREPARATION	6	Preliminary Check	36
Special Service Tools	6	SETTING CHANGE FUNCTION	36
Commercial Service Tools	6	POWER SUPPLY AND GROUND CIRCUIT INSPECTION	36
SQUEAK AND RATTLE TROUBLE DIAGNOSES	7	CONSULT-II Function	39
Work Flow	7	CONSULT-II BASIC OPERATION PROCEDURE	39
CUSTOMER INTERVIEW	7	IVMS COMMUNICATION INSPECTION	40
DUPLICATE THE NOISE AND TEST DRIVE	8	COMMUNICATION SYSTEM A	41
CHECK RELATED SERVICE BULLETINS	8	COMMUNICATION SYSTEM B	42
LOCATE THE NOISE AND IDENTIFY THE ROOT CAUSE	8	COMMUNICATION SYSTEM C	42
REPAIR THE CAUSE	8	WORK SUPPORT	43
CONFIRM THE REPAIR	9	SELF-DIAGNOSIS RESULTS	43
Generic Squeak and Rattle Troubleshooting	9	DATA MONITOR	44
INSTRUMENT PANEL	9	ACTIVE TEST	45
CENTER CONSOLE	9	On Board Diagnosis	46
DOORS	9	DIAGNOSIS ITEM	46
TRUNK	10	COMMUNICATION DIAGNOSIS	47
SUNROOF/HEADLINING	10	COMMUNICATION SYSTEM A	48
SEATS	10	COMMUNICATION SYSTEM B	49
UNDERHOOD	10	COMMUNICATION SYSTEM C	49
Diagnostic Worksheet	11	SWITCH MONITOR	50
AUTOMATIC DRIVE POSITIONER	13	ON BOARD DIAGNOSIS FOR AUTOMATIC DRIVE POSITIONER	51
System Description	13	Symptom Chart	53
MANUAL OPERATION	13	Sliding Motor Circuit Inspection	55
AUTOMATIC OPERATION	13	Reclining Motor Circuit Inspection	56
FAIL-SAFE MODE	13	Front Lifting Motor Circuit Inspection	57
CANCEL OF FAIL-SAFE MODE	14	Rear Lifting Motor Circuit Inspection	59
MEMORY STORING	14	Telescopic Motor Circuit Inspection	60
MEMORY SWITCH OPERATION	15	Tilt Motor Circuit Inspection	62
TURNOUT OPERATION	15	Sliding Sensor Circuit Inspection	64
RETURN OPERATION	16	Reclining Sensor Circuit Inspection	65
REAR POWER SEAT TURNOUT OPERATION	16	Front Lifting sensor Circuit Inspection	66
Component Parts and Harness Connector Location	17		

Rear Lifting Sensor Circuit Inspection	67	Rear Power Seat Control Unit Power Supply and Ground Inspection (Without Heated Seat)	120
Detention Switch Circuit Inspection	68	Rear Power Seat Sliding Motor Circuit Inspection (Without Heated Seat)	120
Telescopic Sensor Circuit Inspection	69	Rear Power Seat Switch Circuit Inspection (Without Heated Seat)	121
Tilt Sensor Circuit Inspection	70	Auto Return Cancel Switch Circuit Inspection 1 (Without Heated Seat)	123
Key Switch and Key Lock Solenoid Circuit Inspection.	71	Auto Return Cancel Switch Circuit Inspection 2 (Without Heated Seat)	123
Front Door Switch (Driver Side) Circuit Inspection...	73	Rear Door Switch Circuit Inspection (Without Heated Seat)	124
Vehicle Speed Signal Inspection	75	Rear Power Seat Sliding Sensor Circuit Inspection (Without Heated Seat)	126
Seat Memory Switch Circuit Inspection	76	HEATED SEAT	127
Sliding Switch Circuit Inspection	78	System Description	127
Reclining Switch System Inspection	80	FRONT HEATED SEAT	127
Front Lifting Switch Circuit Inspection	82	REAR HEATED SEAT	127
Rear Lifting Switch Circuit Inspection	84	Component Parts and Harness Connector Location	129
Telescopic Switch Inspection	86	Wiring Diagram—HSEAT—	130
Tilt Switch Inspection	88	FRONT HEATED SEAT	130
Seat Memory Indicator lamp System Inspection ...	90	Schematic	132
Lumber Support Circuit Inspection	91	REAR HEATED SEAT	132
Rear Power Seat Turnout Operation Inspection ...	93	Wiring Diagram —HSEAT—	133
POWER SEAT	94	REAR HEATED SEAT	133
System Description	94	Terminals and Reference Values for Rear Power Seat Control Unit LH and RH	138
FRONT POWER SEAT (PASSENGER SIDE) OPERATION	94	Work Flow	138
REAR POWER SEAT LH AND REAR POWER SEAT RH OPERATION	95	Trouble Diagnoses Symptom Chart	139
REAR SEAT TURNOUT/RETURN FUNCTION...	96	Heated Seat Power Supply Circuit Inspection	140
Component Parts and Harness Connector Location..	97	Front Heated Seat Switch Inspection	140
Schematic	98	Front Heated Seat Circuit Inspection 1	141
Wiring Diagram—SEAT—	99	Front Heated Seat Circuit Inspection 2	143
Terminals and Reference Values for Passenger Side Power Seat Switch	105	Front Heated Seat Circuit Inspection 3	145
Terminals and Reference Values for Rear Power Seat Control Unit	105	Front Heated Seat Switch Ground Circuit Inspection	146
Work Flow	106	Rear Power Seat Control Unit Power Supply Circuit Inspection 1	147
Trouble Diagnoses Symptom Chart	106	Rear Power Seat Control Unit Power Supply and Ground Circuit Inspection	148
Power Seat Switch Circuit Inspection	108	Rear Power Seat Switch (Heater Switch) Ground Circuit Inspection	149
Front Power Seat Passenger Side Power Supply Circuit Inspection	108	Rear Heated Seat Circuit Inspection	150
Front Power Seat (Passenger Side) Sliding Circuit Inspection	109	Rear Heated Seat Circuit Inspection 2	151
Front Power Seat Passenger Side Reclining Circuit Inspection	110	Rear Heated Seat Circuit Inspection 3	152
Front Power Seat Passenger Side Front Lifting Circuit Inspection	111	Rear Heated Seat Switch Low Circuit Inspection .	154
Front Power Seat Passenger Side Rear Lifting Circuit Inspection	112	Rear Heated Seat Switch High Circuit Inspection.	155
Rear Power Seat Control unit Power Supply and Ground Circuit Inspection (With Heated Seat)	112	Rear Heated Seat Ground Circuit Inspection	156
Rear Power Seat Sliding Motor Circuit Inspection (With Heated Seat)	113	CLIMATE CONTROLLED SEAT	157
Rear Power Seat Switch Circuit Inspection (With Heated Seat)	114	System Description	157
Auto Return Cancel Switch Circuit Inspection 1 (With Heated Seat)	116	Component Parts and Harness Connector Location	160
Auto Return Cancel Switch Circuit Inspection 2 (With Heated Seat)	116	Schematic	161
Rear Door Switch Circuit Inspection (With Heated Seat)	117	Wiring Diagram—C/SEAT—	162
Rear Power Seat Sliding Sensor Circuit Inspection (With Heated Seat)	119	Terminal and Reference Value For Climate Controlled Seat Control Unit	167
		Work Flow	168
		Preliminary Check	168
		Trouble Diagnoses Symptom Chart	169
		Climate Controlled Relay Power Supply Circuit Check	170

Driver Side Climate Controlled Seat Control Unit Power Supply and Ground Circuit Inspection	171	PASSENGER SIDE POWER SEAT	190	A
Passenger Side Climate Controlled Seat Control Unit Power Supply Circuit Inspection	172	REMOVAL	191	
Climate Controlled Seat "HEAT" Switch Circuit Inspection	174	INSTALLATION	192	B
Climate Controlled Seat "COOL" Switch Circuit Inspection	175	Disassembly and Assembly	192	
Climate Controlled Seat Temperature Dial Inspection	176	DISASSEMBLY OF SEATBACK TRIM AND PAD	192	C
Climate Controlled Seat Temperature Dial Circuit Inspection	177	ASSEMBLY OF SEATBACK TRIM AND PAD	193	
Climate Controlled Seat Switch Ground Circuit Inspection	178	REMOVAL OF SEATBACK ASSEMBLY	193	D
Seat Cushion Thermal Electric Device Circuit Inspection	179	INSTALLATION OF SEATBACK ASSEMBLY	193	
Seat Cushion Thermal Electric Device Sensor Circuit Inspection	180	DISASSEMBLY OF SEAT CUSHION TRIM AND PAD	193	E
Seat Back Thermal Electric Device Circuit Inspection	181	ASSEMBLY OF SEAT CUSHION TRIM AND PAD	194	
Seatback Thermal Electric Device Sensor Circuit Inspection	182	CLIMATE CONTROLLED SEAT	194	F
Blower Motor Power Supply Circuit Inspection	182	REAR SEAT	195	
Blower Motor Speed Control Circuit Inspection	184	Removal and Installation	195	G
Blower Motor Tachometer Signal Circuit Inspection	184	MANUAL SEAT (BENCH SEAT)	195	
Climate Controlled Seat Control Unit Inspection	185	POWER SEAT (SPLIT CUSHION)	196	H
FRONT SEAT	186	CENTER SEATBACK ASSEMBLY	197	
Removal and Installation	186	REMOVAL OF MANUAL SEAT (BENCH SEAT)	198	F
DRIVER SIDE POWER SEAT	186	INSTALLATION OF MANUAL SEAT (BENCH SEAT)	198	
CLIMATE CONTROLLED SEAT	188	REMOVAL OF POWER SEAT (SPLIT SEAT)	198	G
		INSTALLATION OF POWER SEAT (SPLIT SEAT)	199	
		Disassembly and Assembly	199	H
		DISASSEMBLY OF SLIDING MOTOR & UNIT	199	
		ASSEMBLY OF SLIDING MOTOR & UNIT	200	J
		DISASSEMBLY OF CENTER SEATBACK ASSEMBLY	200	
		ASSEMBLY OF CENTER SEATBACK ASSEMBLY	201	K
				L
				M

SE

PRECAUTIONS

PRECAUTIONS

PFP:00001

Precautions for Supplemental Restraint System (SRS) “AIR BAG” and “SEAT BELT PRE-TENSIONER”

EIS0041B

The Supplemental Restraint System such as “AIR BAG” and “SEAT BELT PRE-TENSIONER”, used along with a front seat belt, helps to reduce the risk or severity of injury to the driver and front passenger for certain types of collision. This system includes seat belt switch inputs and dual stage front air bag modules. The SRS system uses the seat belt switches to determine the front air bag deployment, and may only deploy one front air bag, depending on the severity of a collision and whether the front occupants are belted or unbelted. Information necessary to service the system safely is included in the SRS and SB section of this Service Manual.

WARNING:

- To avoid rendering the SRS inoperative, which could increase the risk of personal injury or death in the event of a collision which would result in air bag inflation, all maintenance must be performed by an authorized NISSAN/INFINITI dealer.
- Improper maintenance, including incorrect removal and installation of the SRS, can lead to personal injury caused by unintentional activation of the system. For removal of Spiral Cable and Air Bag Module, see the SRS section.
- Do not use electrical test equipment on any circuit related to the SRS unless instructed to in this Service Manual. SRS wiring harnesses can be identified by yellow and/or orange harnesses or harness connectors.

Service Notice

EIS0000M

- When removing or installing various parts, place a cloth or padding onto the vehicle body to prevent scratches.
- Handle trim, molding, instruments, grille, etc. carefully during removing or installing. Be careful not to oil or damage them.
- Apply sealing compound where necessary when installing parts.
- When applying sealing compound, be careful that the sealing compound does not protrude from parts.
- When replacing any metal parts (for example body outer panel, members, etc.), be sure to take rust prevention measures.

Precautions for Work

EIS000E4

- When removing or disassembling each component, be careful not to damage or deform it. If a component may be subject to interference, be sure to protect it with a shop cloth.
- When removing (disengaging) components with a screwdriver or similar tool, be sure to wrap the component with a shop cloth or vinyl tape to protect it.
- Protect the removed parts with a shop cloth and keep them.
- Replace a deformed or damaged clip.
- If a part is specified as a non-reusable part, always replace it with new one.
- Be sure to tighten bolts and nuts securely to the specified torque.
- After re-installation is completed, be sure to check that each part works normally.
- Follow the steps below to clean components.
 - Water soluble foul: Dip a soft cloth into lukewarm water, and wring the water out of the cloth to wipe the fouled area.
Then rub with a soft and dry cloth.
 - Oily foul: Dip a soft cloth into lukewarm water with mild detergent (concentration: within 2 to 3%), and wipe the fouled area.
Then dip a cloth into fresh water, and wring the water out of the cloth to wipe the detergent off. Then rub with a soft and dry cloth.
- Do not use organic solvent such as thinner, benzene, alcohol, and gasoline.
- For genuine leather seats, use a genuine leather seat cleaner.

PRECAUTIONS

Trouble Diagnosis Precaution

E/S000E5

- When carrying out the IVMS control unit input/output signal inspection, be sure to connect the checking adapter III (special service tool) to prevent incorrect diagnosis.
- With the battery connected, if each local control unit (LCU) connector is left disconnected for at least 1 minute, the IVMS control unit stores a communication inactive failure. After reconnecting the connector, any of the following steps shall be done. "Disconnect the IVMS control unit battery power supply" or "Using CONSULT-II, execute Erase memory".

A

B

C

D

E

F

G

H

SE

J

K

L

M

PREPARATION

PREPARATION

PFP:00002

Special Service Tools

EIS000ZQ

The actual shapes of Kent-Moore tools may differ from those of special service tools illustrated here.

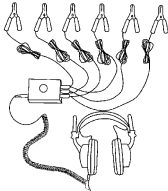
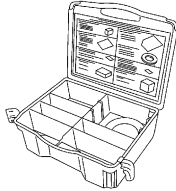
Tool number (Kent-Moore No.) Tool name	Description
<p>(J-39570) Chassis ear</p>  <p style="text-align: right;">SIIA0993E</p>	<p>Locating the noise</p>
<p>(J-43980) NISSAN Squeak and Rattle Kit</p>  <p style="text-align: right;">SIIA0994E</p>	<p>Repairing the cause of noise</p>

Commercial Service Tools

EIS000ZR

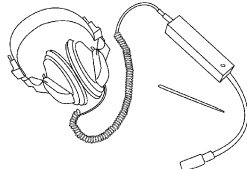
Tool name	Description
<p>Engine ear</p>  <p style="text-align: right;">SIIA0995E</p>	<p>Locating the noise</p>

SQUEAK AND RATTLE TROUBLE DIAGNOSES

SQUEAK AND RATTLE TROUBLE DIAGNOSES

PFP:00000

Work Flow

EIS00A5N

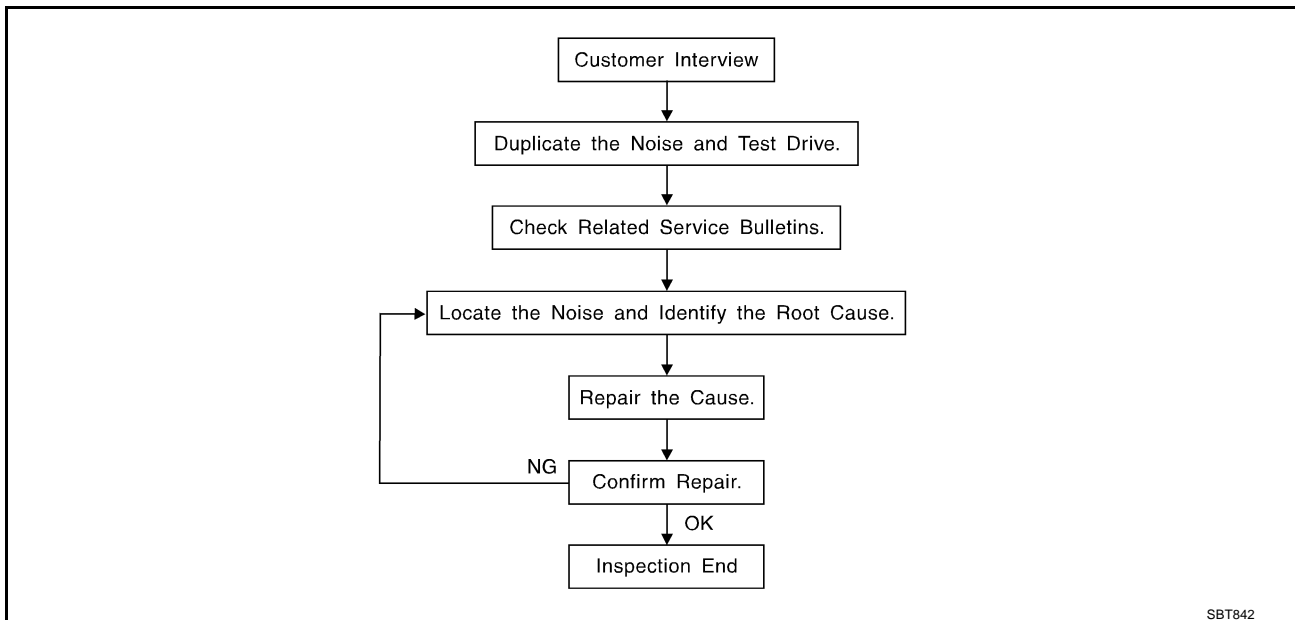

CUSTOMER INTERVIEW

Interview the customer if possible, to determine the conditions that exist when the noise occurs. Use the Diagnostic Worksheet during the interview to document the facts and conditions when the noise occurs and any customer's comments; refer to [SE-11, "Diagnostic Worksheet"](#). This information is necessary to duplicate the conditions that exist when the noise occurs.

- The customer may not be able to provide a detailed description or the location of the noise. Attempt to obtain all the facts and conditions that exist when the noise occurs (or does not occur).
- If there is more than one noise in the vehicle, be sure to diagnose and repair the noise that the customer is concerned about. This can be accomplished by test driving the vehicle with the customer.
- After identifying the type of noise, isolate the noise in terms of its characteristics. The noise characteristics are provided so the customer, service adviser and technician are all speaking the same language when defining the noise.
- Squeak—(Like tennis shoes on a clean floor)
Squeak characteristics include the light contact/fast movement/brought on by road conditions/hard surfaces=higher pitch noise/softer surfaces=lower pitch noises/edge to surface=chirping
- Creak—(Like walking on an old wooden floor)
Creak characteristics include firm contact/slow movement/twisting with a rotational movement/pitch dependent on materials/often brought on by activity.
- Rattle—(Like shaking a baby rattle)
Rattle characteristics include the fast repeated contact/vibration or similar movement/loose parts/missing clip or fastener/incorrect clearance.
- Knock—(Like a knock on a door)
Knock characteristics include hollow sounding/sometimes repeating/often brought on by driver action.
- Tick—(Like a clock second hand)
Tick characteristics include gentle contacting of light materials/loose components/can be caused by driver action or road conditions.
- Thump—(Heavy, muffled knock noise)
Thump characteristics include softer knock/dead sound often brought on by activity.
- Buzz—(Like a bumble bee)
Buzz characteristics include high frequency rattle/firm contact.
- Often the degree of acceptable noise level will vary depending upon the person. A noise that you may judge as acceptable may be very irritating to the customer.
- Weather conditions, especially humidity and temperature, may have a great effect on noise level.

SQUEAK AND RATTLE TROUBLE DIAGNOSES

DUPLICATE THE NOISE AND TEST DRIVE

If possible, drive the vehicle with the customer until the noise is duplicated. Note any additional information on the Diagnostic Worksheet regarding the conditions or location of the noise. This information can be used to duplicate the same conditions when you confirm the repair.

If the noise can be duplicated easily during the test drive, to help identify the source of the noise, try to duplicate the noise with the vehicle stopped by doing one or all of the following:

- 1) Close a door.
 - 2) Tap or push/pull around the area where the noise appears to be coming from.
 - 3) Rev the engine.
 - 4) Use a floor jack to recreate vehicle "twist".
 - 5) At idle, apply engine load (electrical load, half-clutch on M/T models, drive position on A/T models).
 - 6) Raise the vehicle on a hoist and hit a tire with a rubber hammer.
- Drive the vehicle and attempt to duplicate the conditions the customer states exist when the noise occurs.
 - If it is difficult to duplicate the noise, drive the vehicle slowly on an undulating or rough road to stress the vehicle body.

CHECK RELATED SERVICE BULLETINS

After verifying the customer concern or symptom, check ASIST for Technical Service Bulletins (TSBs) related to that concern or symptom.

If a TSB relates to the symptom, follow the procedure to repair the noise.

LOCATE THE NOISE AND IDENTIFY THE ROOT CAUSE

1. Narrow down the noise to a general area. To help pinpoint the source of the noise, use a listening tool (Chassis Ear: J-39570, Engine Ear and mechanics stethoscope).
2. Narrow down the noise to a more specific area and identify the cause of the noise by:
 - removing the components in the area that you suspect the noise is coming from.
Do not use too much force when removing clips and fasteners, otherwise clips and fastener can be broken or lost during the repair, resulting in the creation of new noise.
 - tapping or pushing/pulling the component that you suspect is causing the noise.
Do not tap or push/pull the component with excessive force, otherwise the noise will be eliminated only temporarily.
 - feeling for a vibration with your hand by touching the component(s) that you suspect is (are) causing the noise.
 - placing a piece of paper between components that you suspect are causing the noise.
 - looking for loose components and contact marks.
Refer to [SE-9, "Generic Squeak and Rattle Troubleshooting"](#) .

REPAIR THE CAUSE

- If the cause is a loose component, tighten the component securely.
- If the cause is insufficient clearance between components:
 - separate components by repositioning or loosening and retightening the component, if possible.
 - insulate components with a suitable insulator such as urethane pads, foam blocks, felt cloth tape or urethane tape. A Nissan Squeak and Rattle Kit (J-43980) is available through your authorized Nissan Parts Department.

CAUTION:

Do not use excessive force as many components are constructed of plastic and may be damaged.

NOTE:

Always check with the Parts Department for the latest parts information.

The following materials are contained in the Nissan Squeak and Rattle Kit (J-43980). Each item can be ordered separately as needed.

URETHANE PADS [1.5 mm (0.059 in) thick]

Insulates connectors, harness, etc.

76268-9E005: 100 × 135 mm (3.94 × 5.31 in)/76884-71L01: 60 × 85 mm (2.36 × 3.35 in)/76884-

71L02: 15 × 25 mm (0.59 × 0.98 in)

INSULATOR (Foam blocks)

Insulates components from contact. Can be used to fill space behind a panel.

73982-9E000: 45 mm (1.77 in) thick, 50 × 50 mm (1.97 × 1.97 in)/73982-

50Y00: 10 mm (0.39 in) thick, 50 × 50 mm (1.97 × 1.97 in)

SQUEAK AND RATTLE TROUBLE DIAGNOSES

INSULATOR (Light foam block)

80845-71L00: 30 mm (1.18 in) thick, 30 × 50 mm (1.18 × 1.97 in)

FELT CLOTHTAPE

Used to insulate where movement does not occur. Ideal for instrument panel applications.

68370-4B000: 15 × 25 mm (0.59 × 0.98 in) pad/68239-13E00: 5 mm (0.20 in) wide tape roll

The following materials, not found in the kit, can also be used to repair squeaks and rattles.

UHMW (TEFLON) TAPE

Insulates where slight movement is present. Ideal for instrument panel applications.

SILICONE GREASE

Used in place of UHMW tape that will be visible or not fit. Will only last a few months.

SILICONE SPRAY

Use when grease cannot be applied.

DUCT TAPE

Use to eliminate movement.

CONFIRM THE REPAIR

Confirm that the cause of a noise is repaired by test driving the vehicle. Operate the vehicle under the same conditions as when the noise originally occurred. Refer to the notes on the Diagnostic Worksheet.

Generic Squeak and Rattle Troubleshooting

EIS00A50

Refer to Table of Contents for specific component removal and installation information.

INSTRUMENT PANEL

Most incidents are caused by contact and movement between:

1. The cluster lid A and instrument panel
2. Acrylic lens and combination meter housing
3. Instrument panel to front pillar garnish
4. Instrument panel to windshield
5. Instrument panel mounting pins
6. Wiring harnesses behind the combination meter
7. A/C defroster duct and duct joint

These incidents can usually be located by tapping or moving the components to duplicate the noise or by pressing on the components while driving to stop the noise. Most of these incidents can be repaired by applying felt cloth tape or silicon spray (in hard to reach areas). Urethane pads can be used to insulate wiring harness.

CAUTION:

Do not use silicone spray to isolate a squeak or rattle. If you saturate the area with silicone, you will not be able to recheck the repair.

CENTER CONSOLE

Components to pay attention to include:

1. Shifter assembly cover to finisher
2. A/C control unit and cluster lid C
3. Wiring harnesses behind audio and A/C control unit

The instrument panel repair and isolation procedures also apply to the center console.

DOORS

Pay attention to the:

1. Finisher and inner panel making a slapping noise
2. Inside handle escutcheon to door finisher
3. Wiring harnesses tapping
4. Door striker out of alignment causing a popping noise on starts and stops

Tapping or moving the components or pressing on them while driving to duplicate the conditions can isolate many of these incidents. You can usually insulate the areas with felt cloth tape or insulator foam blocks from the Nissan Squeak and Rattle Kit (J-43980) to repair the noise.

A
B
C
D
E
F
G
H
SE
J
K
L
M

SQUEAK AND RATTLE TROUBLE DIAGNOSES

TRUNK

Trunk noises are often caused by a loose jack or loose items put into the trunk by the owner. In addition look for:

1. Trunk lid dumpers out of adjustment
2. Trunk lid striker out of adjustment
3. The trunk lid torsion bars knocking together
4. A loose license plate or bracket

Most of these incidents can be repaired by adjusting, securing or insulating the item(s) or component(s) causing the noise.

SUNROOF/HEADLINING

Noises in the sunroof/headlining area can often be traced to one of the following:

1. Sunroof lid, rail, linkage or seals making a rattle or light knocking noise
2. Sunvisor shaft shaking in the holder
3. Front or rear windshield touching headlining and squeaking

Again, pressing on the components to stop the noise while duplicating the conditions can isolate most of these incidents. Repairs usually consist of insulating with felt cloth tape.

SEATS

When isolating seat noise it's important to note the position the seat is in and the load placed on the seat when the noise is present. These conditions should be duplicated when verifying and isolating the cause of the noise.

Cause of seat noise include:

1. Headrest rods and holder
2. A squeak between the seat pad cushion and frame
3. The rear seatback lock and bracket

These noises can be isolated by moving or pressing on the suspected components while duplicating the conditions under which the noise occurs. Most of these incidents can be repaired by repositioning the component or applying urethane tape to the contact area.

UNDERHOOD

Some interior noise may be caused by components under the hood or on the engine wall. The noise is then transmitted into the passenger compartment.

Causes of transmitted underhood noise include:

1. Any component mounted to the engine wall
2. Components that pass through the engine wall
3. Engine wall mounts and connectors
4. Loose radiator mounting pins
5. Hood bumpers out of adjustment
6. Hood striker out of adjustment

These noises can be difficult to isolate since they cannot be reached from the interior of the vehicle. The best method is to secure, move or insulate one component at a time and test drive the vehicle. Also, engine RPM or load can be changed to isolate the noise. Repairs can usually be made by moving, adjusting, securing, or insulating the component causing the noise.

SQUEAK AND RATTLE TROUBLE DIAGNOSES

Diagnostic Worksheet

EIS00A5P



SQUEAK & RATTLE DIAGNOSTIC WORKSHEET

Dear Infiniti Customer:

We are concerned about your satisfaction with your Infiniti vehicle. Repairing a squeak or rattle sometimes can be very difficult. To help us fix your Infiniti right the first time, please take a moment to note the area of the vehicle where the squeak or rattle occurs and under what conditions. You may be asked to take a test drive with a service advisor or technician to ensure we confirm the noise you are hearing.

I. WHERE DOES THE NOISE COME FROM? (circle the area of the vehicle)

The illustrations are for reference only, and may not reflect the actual configuration of your vehicle.

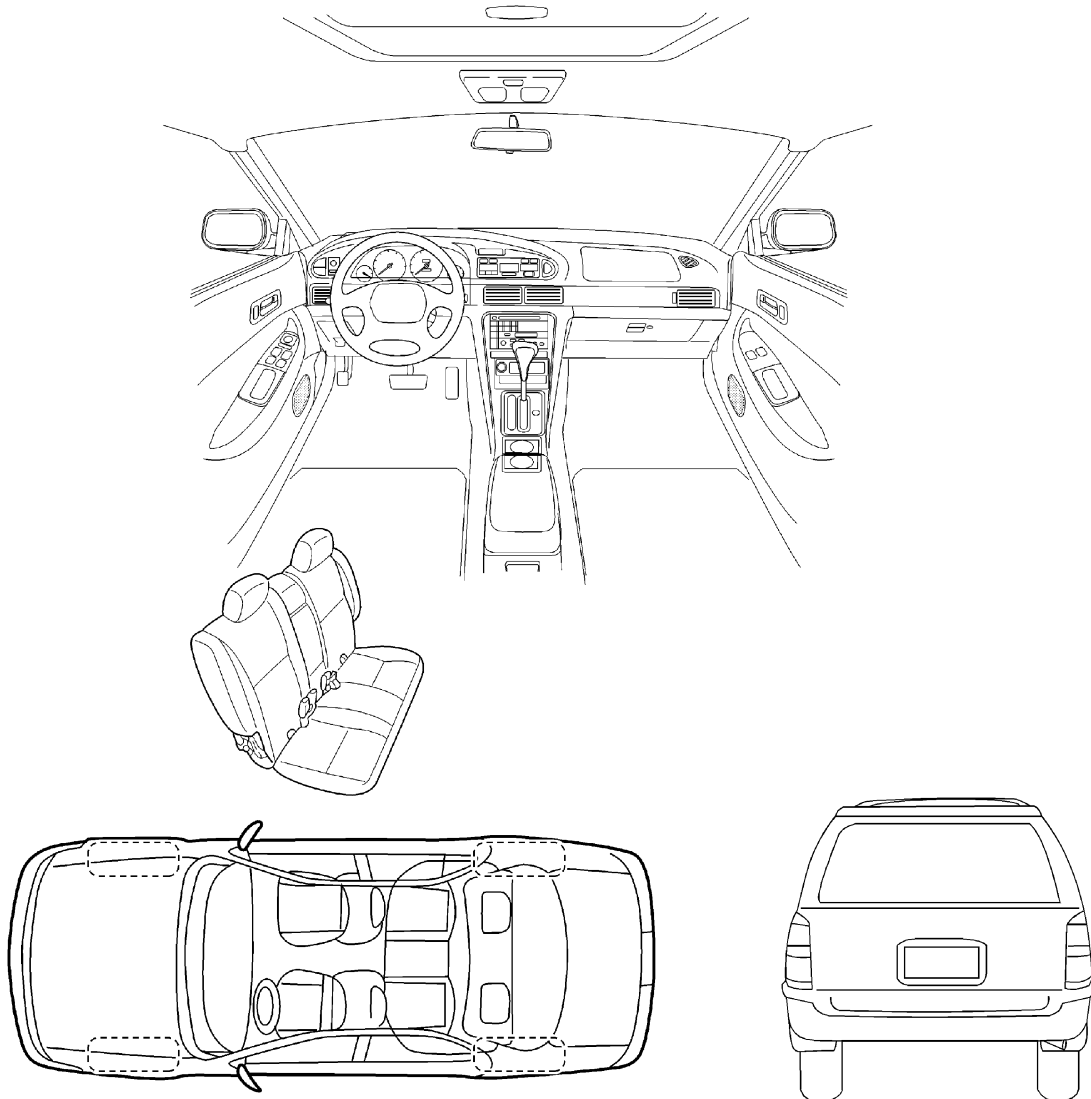

Continue to the back of the worksheet and briefly describe the location of the noise or rattle. In addition, please indicate the conditions which are present when the noise occurs.

SBT860

A
B
C
D
E
F
G
H
SE
J
K
L
M

SQUEAK AND RATTLE TROUBLE DIAGNOSES

SQUEAK & RATTLE DIAGNOSTIC WORKSHEET- page 2

Briefly describe the location where the noise occurs:

II. WHEN DOES IT OCCUR? (check the boxes that apply)

- | | |
|--|---|
| <input type="checkbox"/> anytime | <input type="checkbox"/> after sitting out in the sun |
| <input type="checkbox"/> 1 st time in the morning | <input type="checkbox"/> when it is raining or wet |
| <input type="checkbox"/> only when it is cold outside | <input type="checkbox"/> dry or dusty conditions |
| <input type="checkbox"/> only when it is hot outside | <input type="checkbox"/> other: _____ |

III. WHEN DRIVING:

- through driveways
- over rough roads
- over speed bumps
- only at about ____ mph
- on acceleration
- coming to a stop
- on turns : left, right or either (circle)
- with passengers or cargo
- other: _____
- after driving ____ miles or ____ minutes

IV. WHAT TYPE OF NOISE?

- squeak (like tennis shoes on a clean floor)
- creak (like walking on an old wooden floor)
- rattle (like shaking a baby rattle)
- knock (like a knock on a door)
- tick (like a clock second hand)
- thump (heavy, muffled knock noise)
- buzz (like a bumble bee)

TO BE COMPLETED BY DEALERSHIP PERSONNEL

Test Drive Notes:

	YES	NO	Initials of person performing
Vehicle test driven with customer	<input type="checkbox"/>	<input type="checkbox"/>	_____
- Noise verified on test drive	<input type="checkbox"/>	<input type="checkbox"/>	_____
- Noise source located and repaired	<input type="checkbox"/>	<input type="checkbox"/>	_____
- Follow up test drive performed to confirm repair	<input type="checkbox"/>	<input type="checkbox"/>	_____

VIN: _____ Customer Name: _____

W.O. #: _____ Date: _____

This form must be attached to Work Order

SBT844

AUTOMATIC DRIVE POSITIONER

AUTOMATIC DRIVE POSITIONER

PPF:28491

System Description

EIS008JZ

- The system automatically moves the driver seat and steering wheel to facilitate entry/exit to/from the vehicle by connecting the BCM (Body Control Module) to the driver seat control unit the multiple communication line. The BCM can also store the optimum driving positions (driver seat, steering wheel and door mirror position) for 2 people. If the driver is changes, one-touch operation allows changing to the other driving position.
- The settings (ON/OFF) of the automatic tilt steering wheel and sliding seat (Entry/exiting function) at entry/exit can be changed as desired, using the display unit in the center of the instrument panel.

MANUAL OPERATION

The driving position (seat position, steering wheel position, door mirror position) can be adjusted with the power seat switch or ADP (Automatic Drive Positioner) steering switch.

NOTE:

- The seat and steering wheel position can be manually operated with the ignition switch OFF.
- The door mirrors can be manually operated with the ignition switch in either ACC or ON.

AUTOMATIC OPERATION

Function		Description
Memory switch operation		The seat, steering wheel and door mirror move to the stored driving position by pushing memory switch.
Entry / Exiting function	Return operation	At entry, the seat and steering wheel return from the exiting position to the previous driving position.
	Turnout operation	At exit, the seat moves backward, and the steering wheel moves forward and upward.

NOTE:

- Disconnecting the battery erases the stored memory.
- After connecting the battery, insert the key into the ignition cylinder and turn the driver door switch ON (open)→OFF (close)→ON (open), the Entry / exiting function becomes possible.

Auto operation stop conditions.	<ul style="list-style-type: none"> ● When the vehicle speed becomes 7 km/h (4 MPH) or higher. ● When the manual switch is operated. ● When any two or more switches among the setting switch, memory switch 1, or 2 are pressed simultaneously. ● When the tilt sensor or telescoping sensor malfunction is detected. ● When the A/T selector lever is shifted to a position other than P-position.
---------------------------------	--

NOTE:

During automatic operation, if the ignition switch is turned ON→START, the automatic operation is suspended. When the ignition switch returns to ON, it resumes.

FAIL-SAFE MODE

When the ignition switch is in the ON position, if any of the parts (indicated in the following chart) move more than the specified amount within a period "T" when no "ON" input is sent from any of the switches (indicated in the following chart), or an output from the automatic drive positioned is not produced, an output malfunction is sensed. Motor operation will be suspended automatically, and all automatic operations will be ineffective. (In this case, the motor will not operate manually).

OPERATED PORTION	T	Allowable measurement
Seat sliding	Approx. 2.5 sec.	Within 6 mm (0.24 in).
Seat reclining	Same as above	Change angel within 2.22°
Steering wheel	Same as above	Change angel within 1°

AUTOMATIC DRIVE POSITIONER

CANCEL OF FAIL-SAFE MODE

- The mode is cancelled when the selector lever is shifted to P-position from any other position.
- The mode can be cancelled with CONSULT-II.

MEMORY STORING

Store the 2 driving positions and shifts to the stored driving position with the memory switch.

PROCEDURE FOR STORING MEMORY

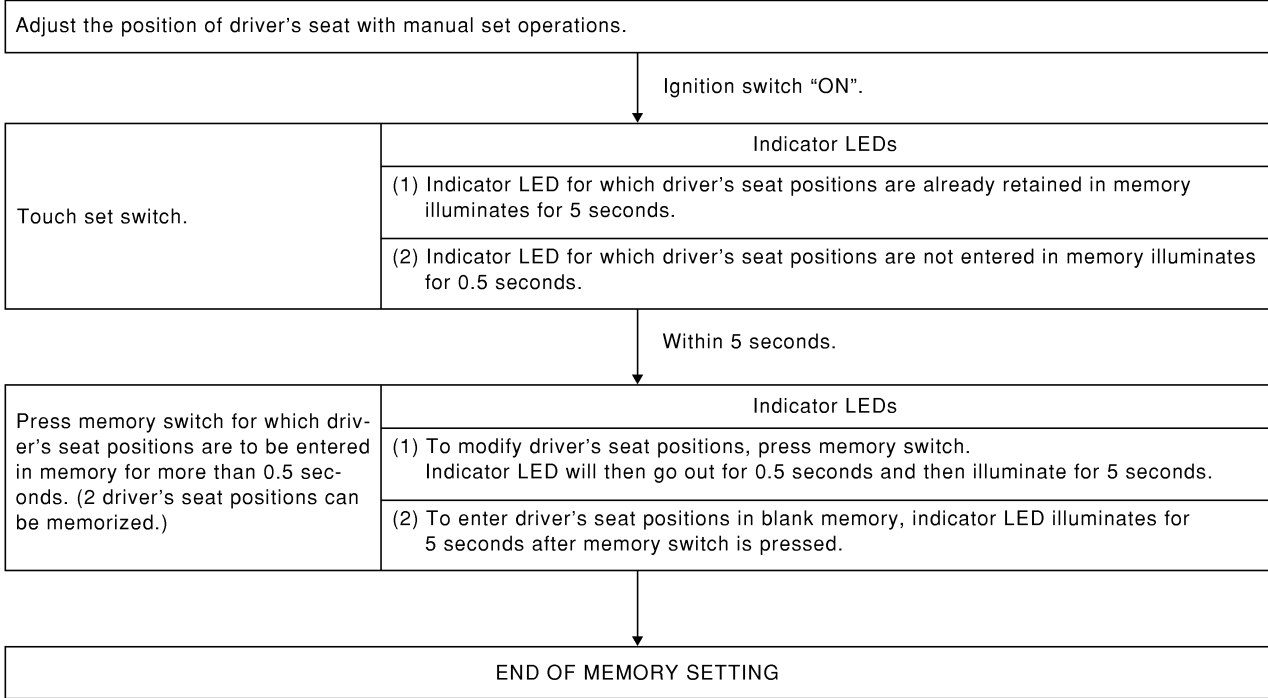

SEL592W

AUTOMATIC DRIVE POSITIONER

MEMORY SWITCH OPERATION

SELECTING THE MEMORIZED POSITION

PROCEDURE-A
Turn ignition switch "ON" and press desired memory switch for more than 0.3 seconds. (Indicator LED illuminates.)

PROCEDURE-B
Open driver's door and withdraw key from ignition key cylinder. Then press desired memory switch for more than 0.3 seconds. (Indicator LED illuminates.) (See NOTE 2.)

(See NOTE 1.)

Within 1 minute

Insert key into ignition key cylinder. (Memory indicator illuminates.)

The driver's seat and steering wheel will move to their memorized positions. (See NOTE 3.)
(During adjustments, indicator LED flashes, then illuminates for 5 seconds after adjustment.)

PIIA4467E

NOTE:

1. Do not setting change as it will not operate. refer to [SE-36, "SETTING CHANGE FUNCTION"](#)
2. Automatic turnout function will be performed.
3. The driver's seat position and steering adjustment (see the following Table) operate simultaneously in the order of priority.

Priority	Function	Priority	Function
1	Seat sliding, (door mirror-LH/RH)*	4	Seat reclining
2	Steering wheel telescopic	5	Seat lifter-FR
3	Steering wheel tilt	6	Seat lifter-RR

*: In conjunction with sliding the seat, the door mirrors are positioned. The mirror moves when the ignition switch is in ACC.

TURNOUT OPERATION

At exit, the seat and steering wheel are automatically moved to the turnout position.

- Seat: moves backward.
- Steering wheel: tilted upward and extended fully.

Remove ignition key from ignition key cylinder.

Open driver's door while ignition key is inserted. (Ignition switch is in "OFF" or "ACC" position.)

Turn ignition switch from "ON" to "OFF" with driver's door opened.

The seat and steering wheel are moved to the turnout position.

PIIA4469E

NOTE:

The seat sliding, steering wheel tilt, and telescoping are moved to the turnout position simultaneously.

AUTOMATIC DRIVE POSITIONER

RETURN OPERATION

When the seat and steering wheel are on the exiting positions, the following operation moves the seat and steering wheel to the previous position before the turnout operation.

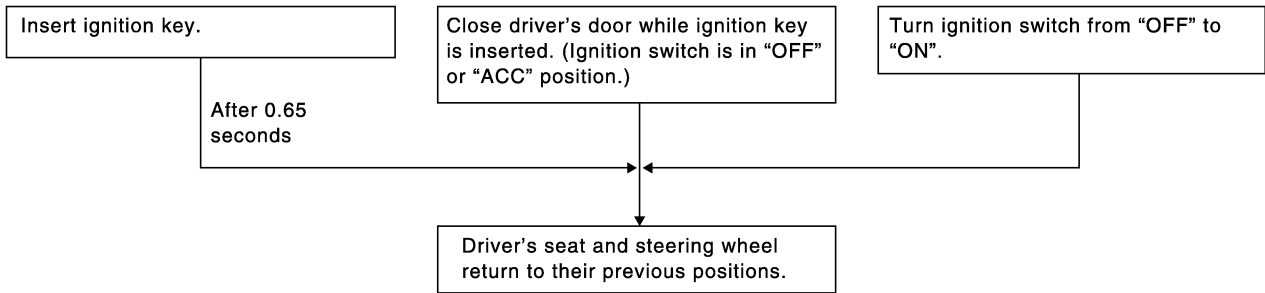

PIIA4468E

NOTE:

The seat sliding, steering wheel tilt, and telescoping return to the original positions simultaneously.

REAR POWER SEAT TURNOUT OPERATION

Rear power seat moves back ward with driver' s seat at the same time in case turnout operation.

AUTOMATIC DRIVE POSITIONER

Component Parts and Harness Connector Location

E/S008K0

A
B
C
D
E
F
G
H
SE
J
K
L
M

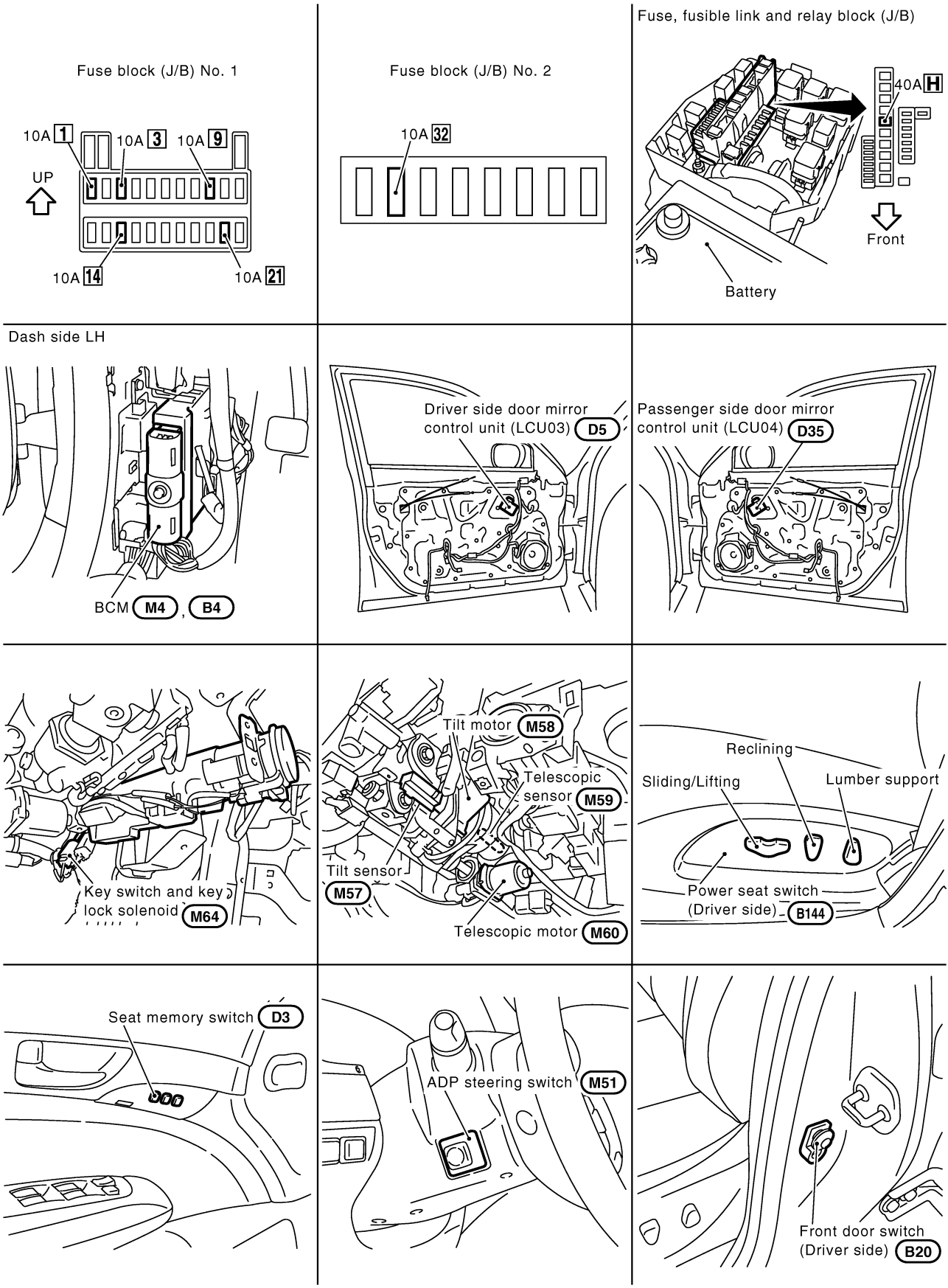

PIIB2130E

AUTOMATIC DRIVE POSITIONER

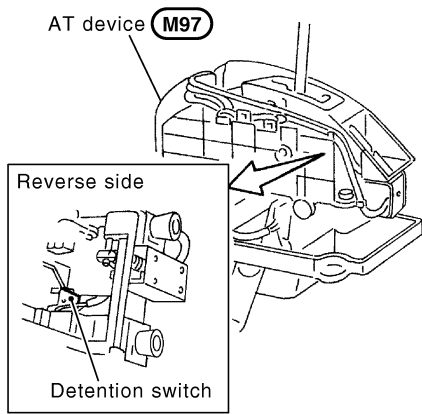
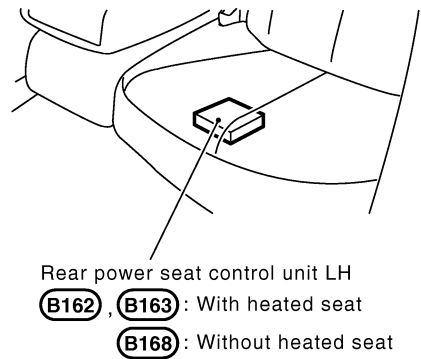
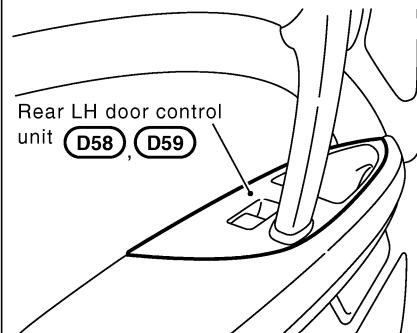
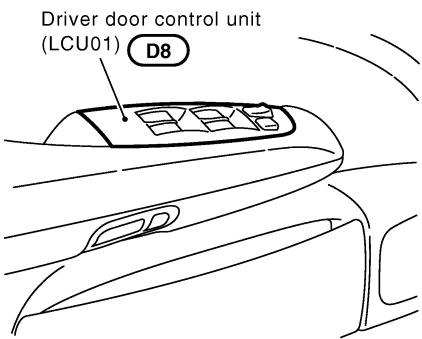
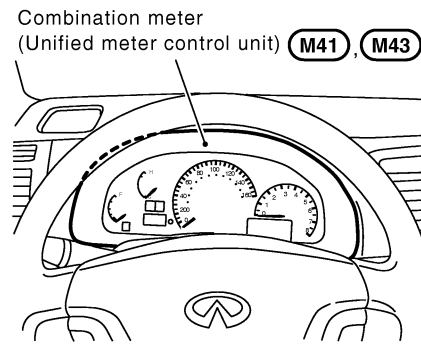
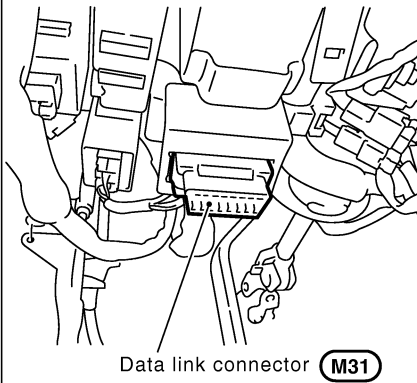
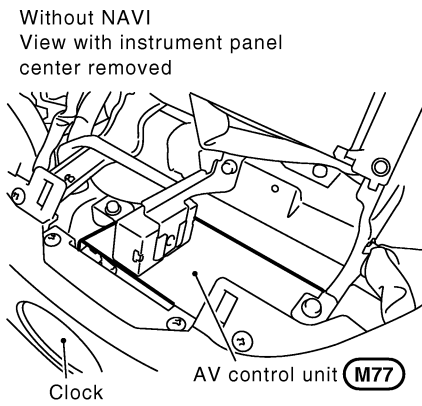
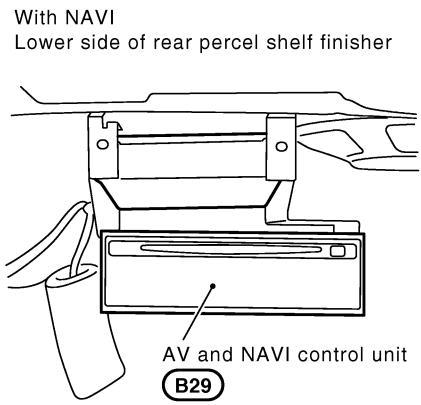
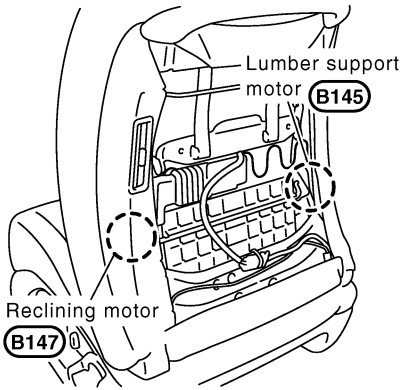
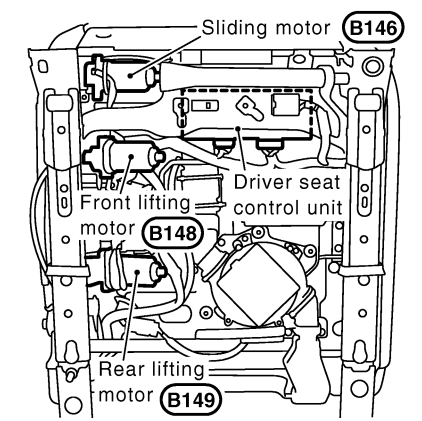

PIIB0297E

AUTOMATIC DRIVE POSITIONER

Schematic

EIS008K1

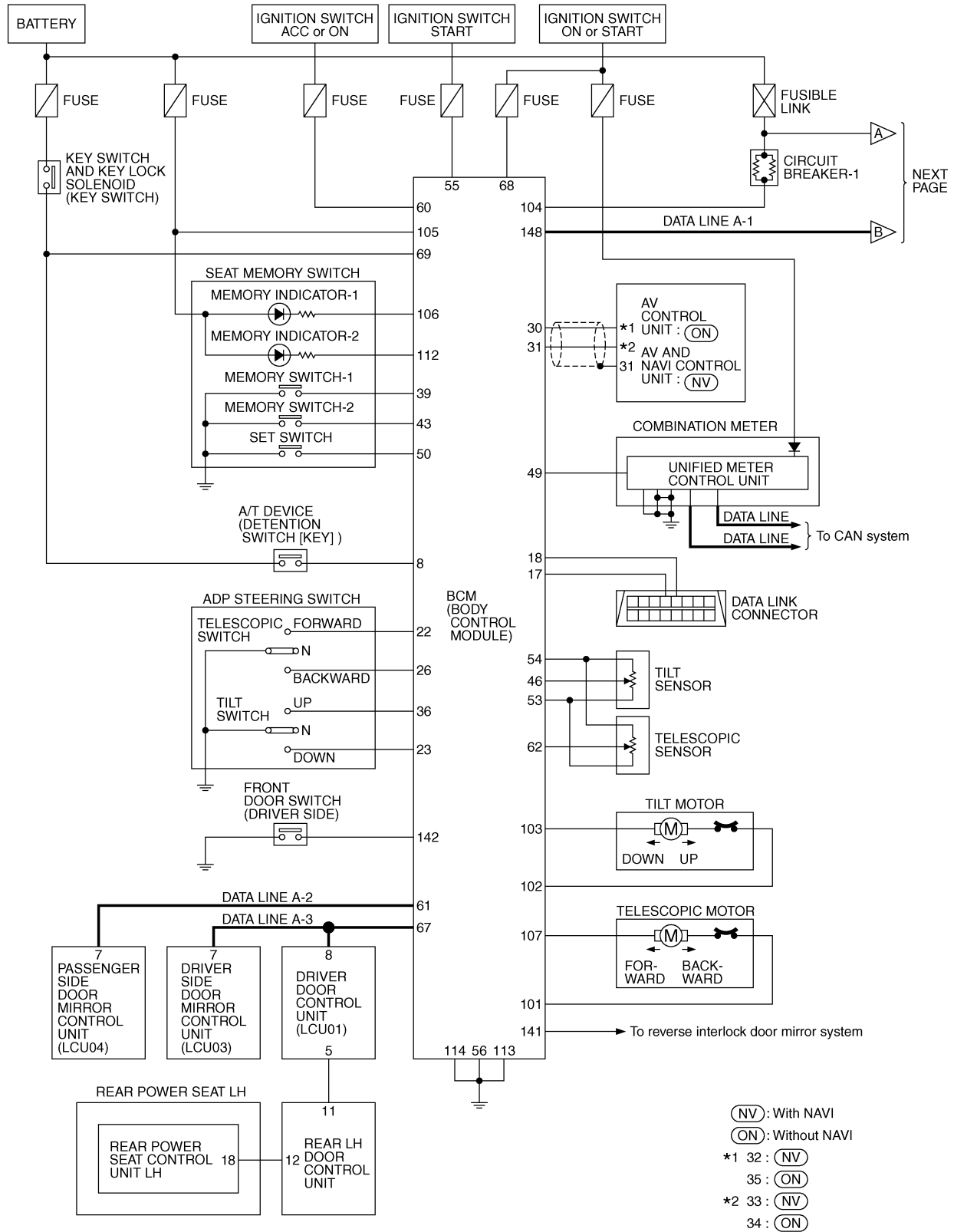

A
 B
 C
 D
 E
 F
 G
 H
 SE
 J
 K
 L
 M

AUTOMATIC DRIVE POSITIONER

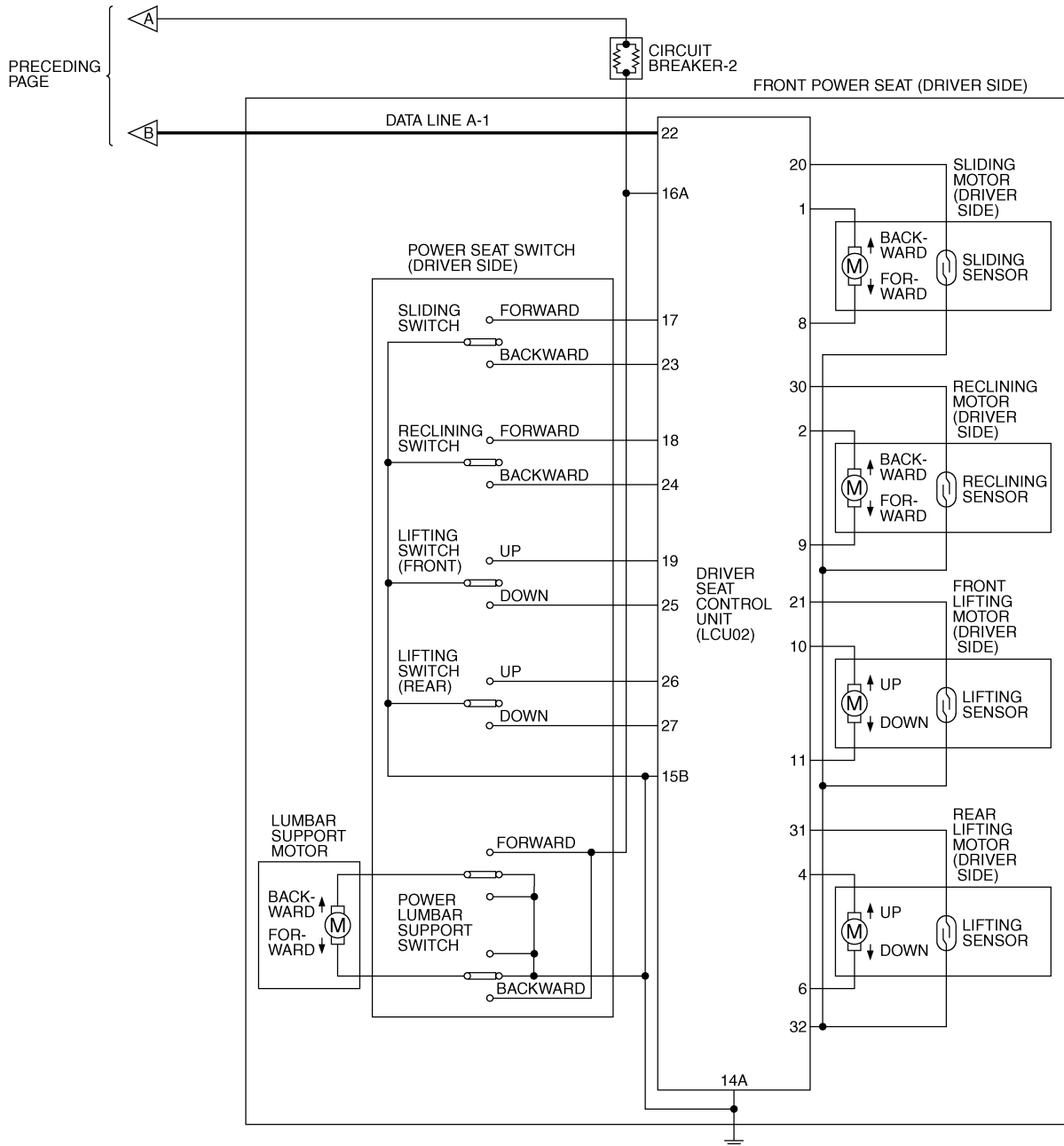

TIWM0274E

AUTOMATIC DRIVE POSITIONER

Wiring Diagram–AUT/DP–

E/S008K2

SE-AUT/DP-01

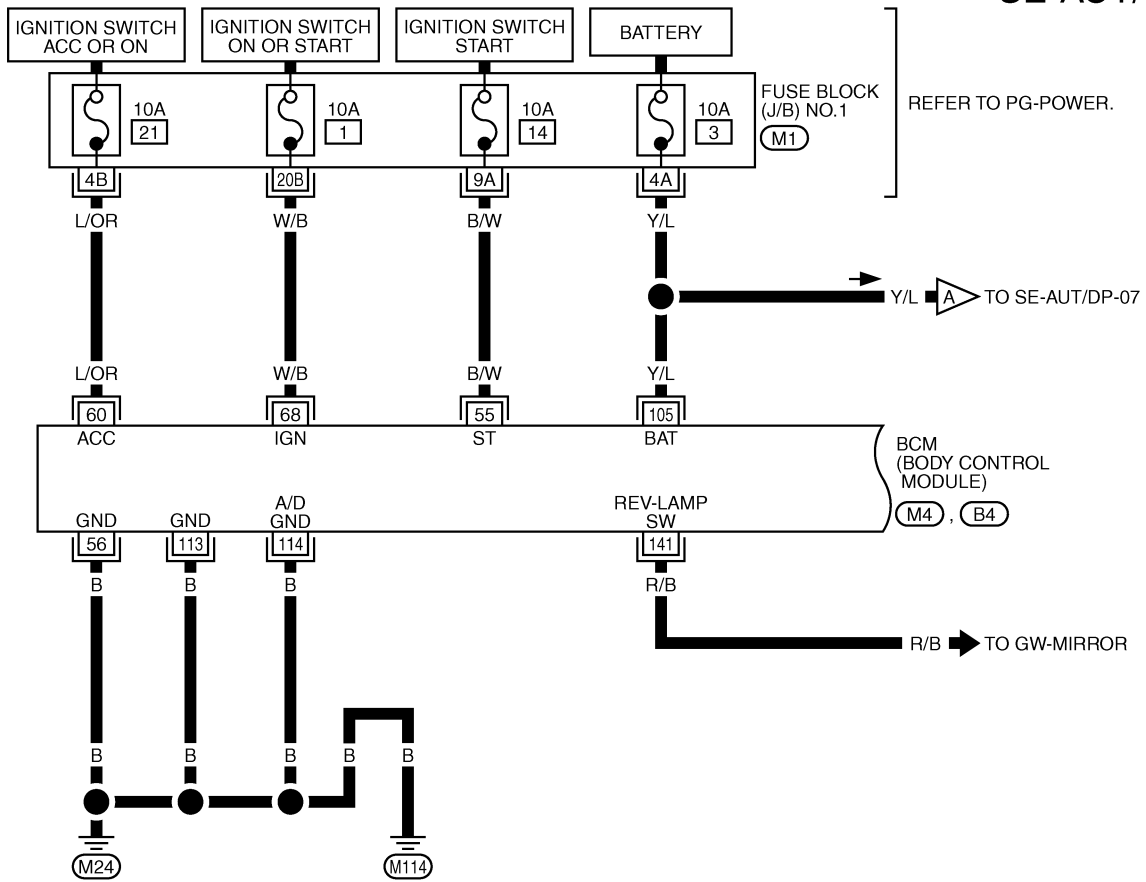

REFER TO PG-POWER.

BCM
(BODY CONTROL
MODULE)

REFER TO THE FOLLOWING.

(M1) - FUSE BLOCK-JUNCTION BOX (J/B) NO.1

(M4), (B4) - ELECTRICAL UNITS

TIVM0724E

A
B
C
D
E
F
G
H
SE
J
K
L
M

AUTOMATIC DRIVE POSITIONER

SE-AUT/DP-02

◊NV◊ : WITH NAVI

◊ON◊ : WITHOUT NAVI

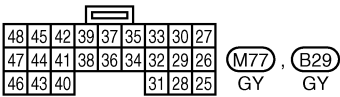
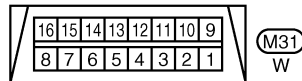
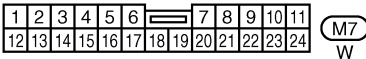
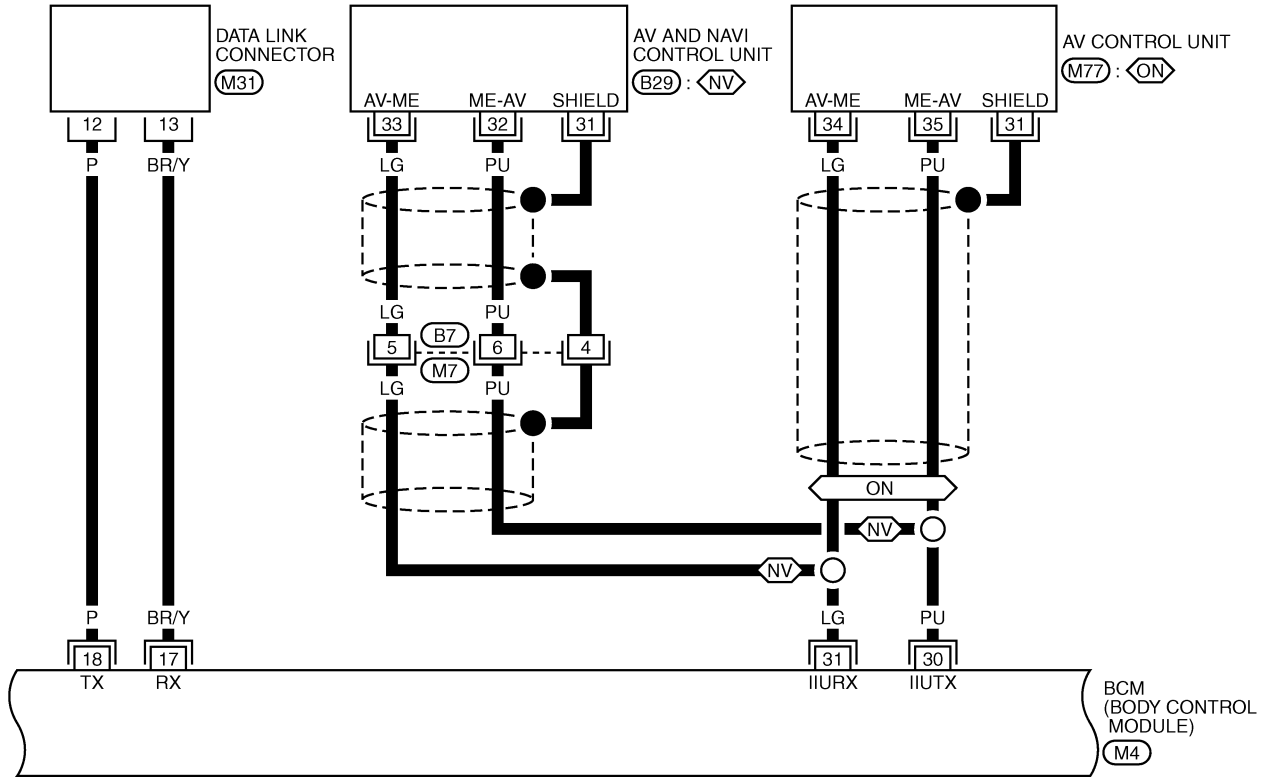

REFER TO THE FOLLOWING.

(M4) -ELECTRICAL UNITS

TIWM0725E

AUTOMATIC DRIVE POSITIONER

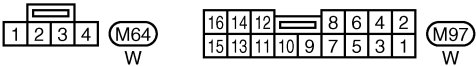
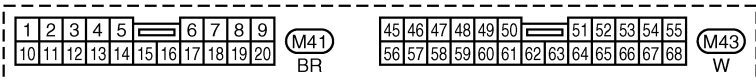
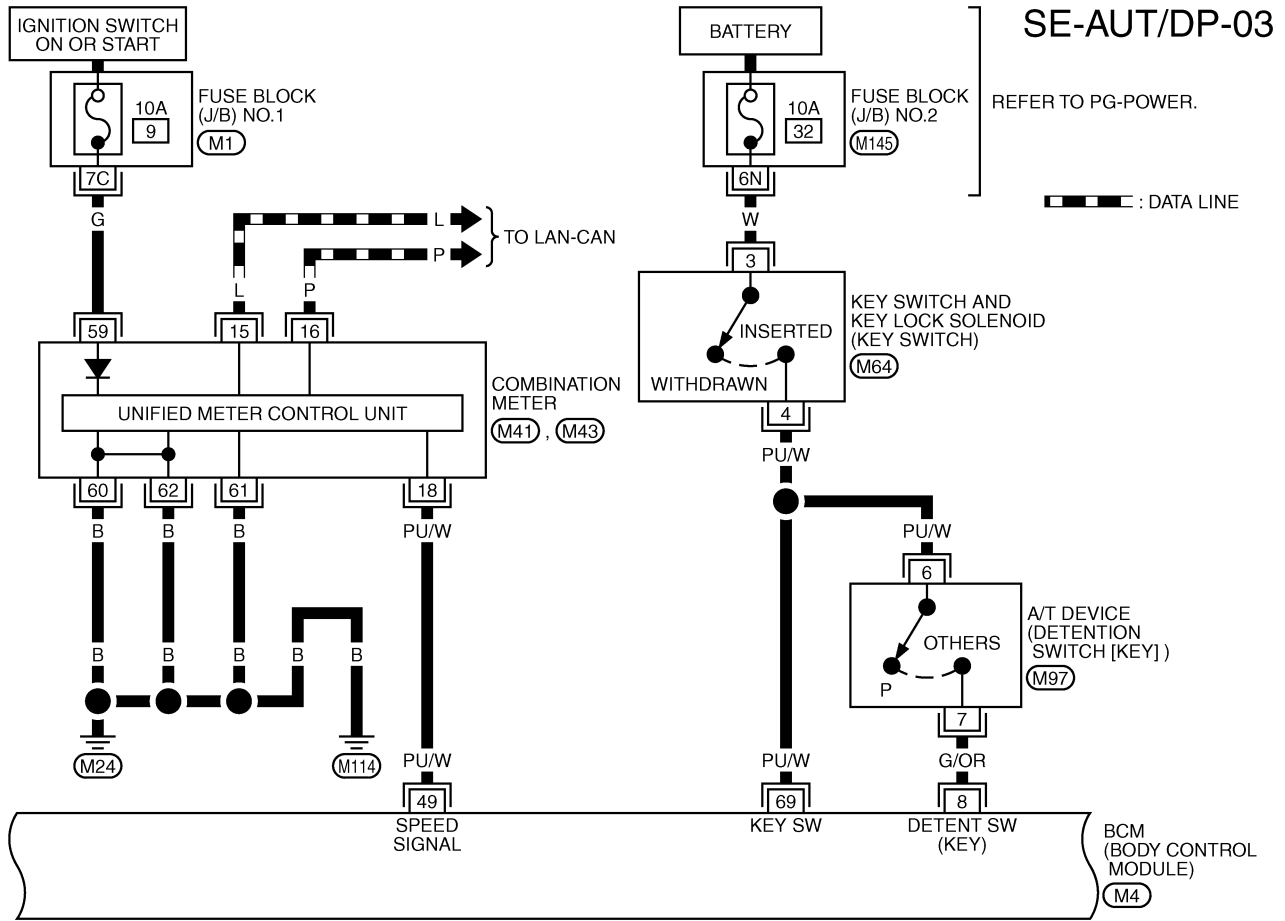

REFER TO THE FOLLOWING.

- (M1) - FUSE BLOCK-JUNCTION BOX (J/B) NO.1
- (M145) - FUSE BLOCK-JUNCTION BOX (J/B) NO.2
- (M4) - ELECTRICAL UNITS

TIVM0726E

A
B
C
D
E
F
G
H
SE
J
K
L
M

AUTOMATIC DRIVE POSITIONER

SE-AUT/DP-04

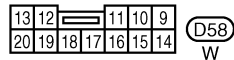
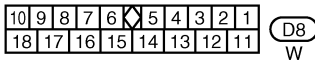
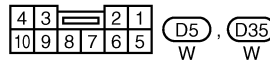
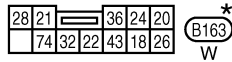
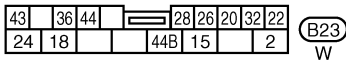
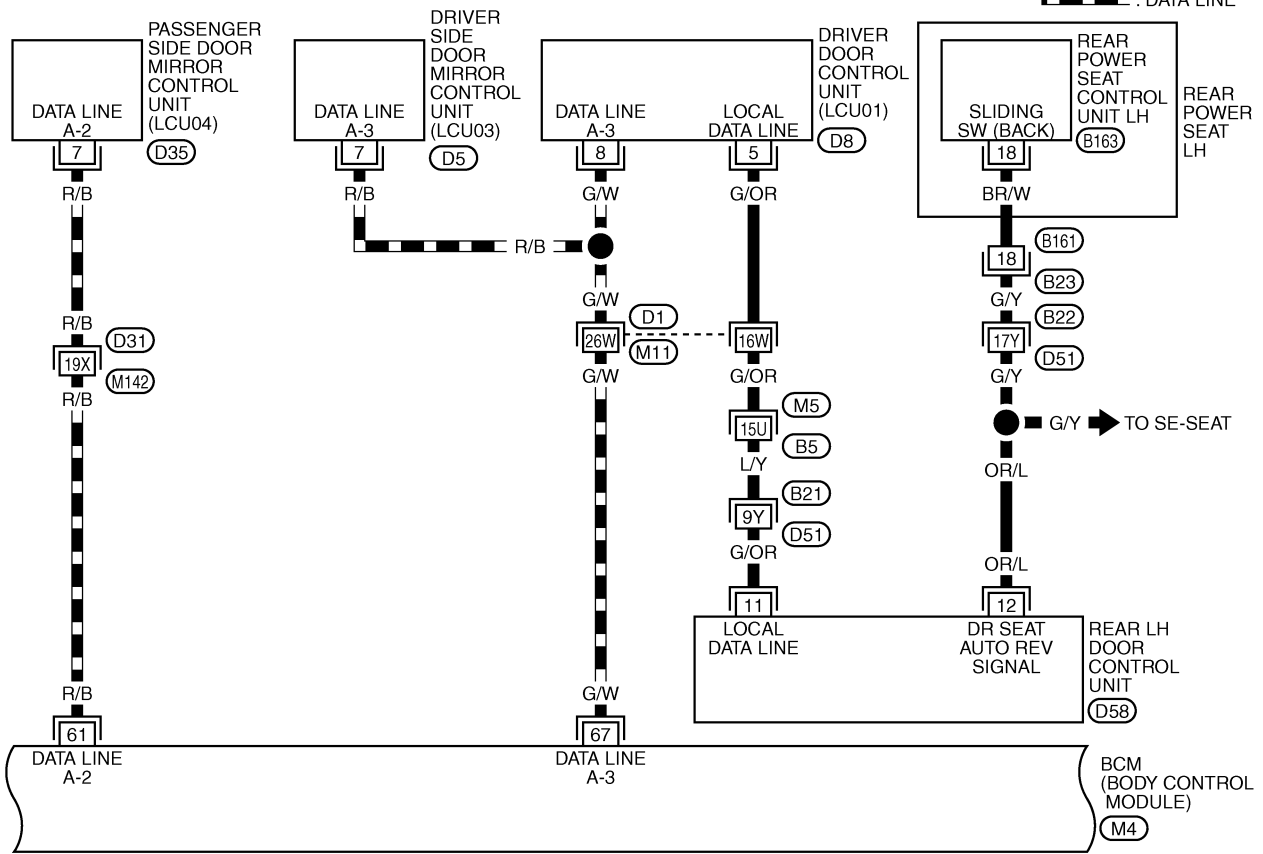

REFER TO THE FOLLOWING.

- (M5), (B21), (B22), (D1),
- (D31) -SUPER MULTIPLE JUNCTION (SMJ)
- (M4) -ELECTRICAL UNITS

*: THIS CONNECTOR IS NOT SHOWN IN "HARNESS LAYOUT", PG SECTION.

TIWM0727E

AUTOMATIC DRIVE POSITIONER

SE-AUT/DP-05

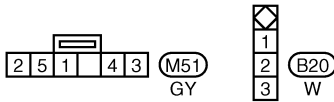
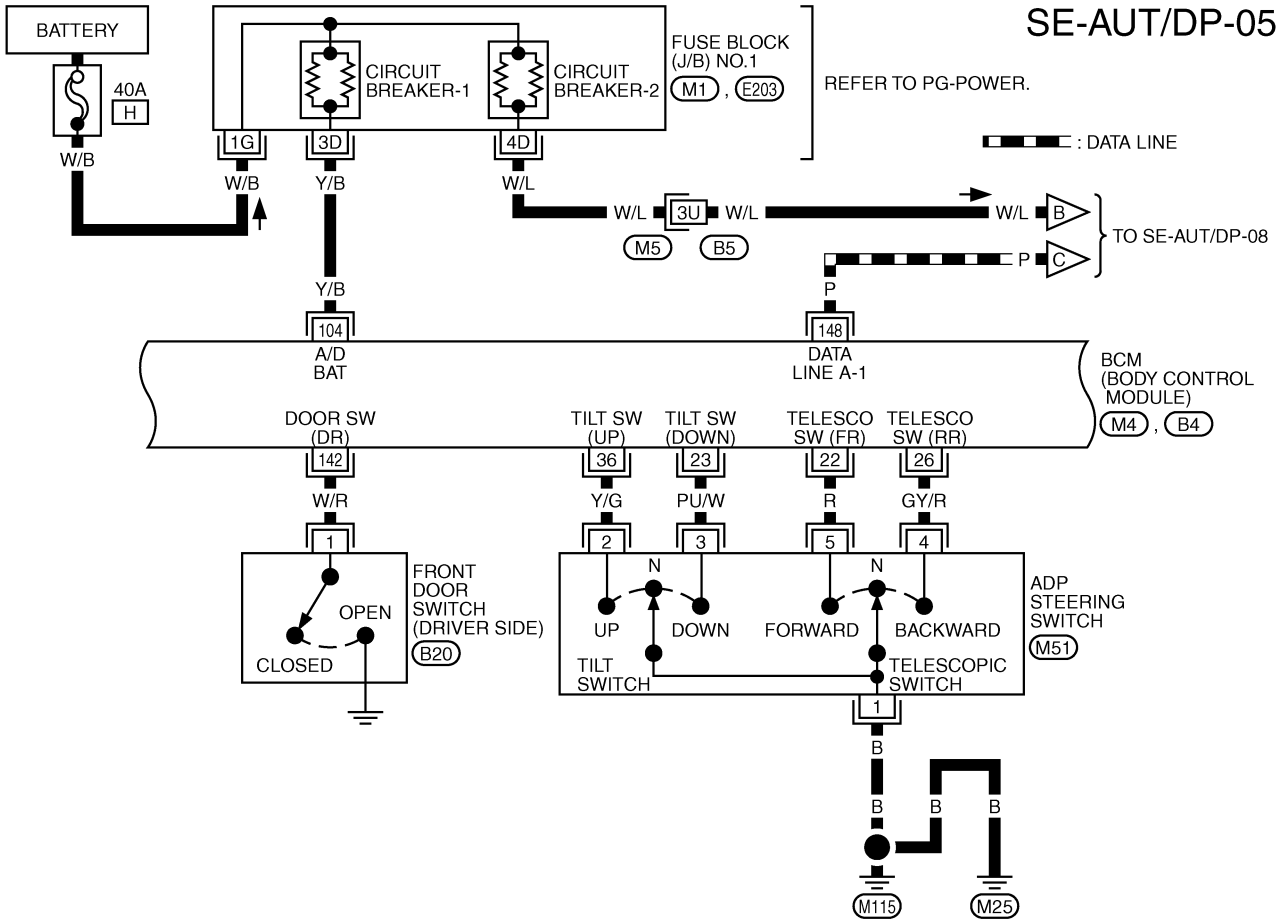

REFER TO THE FOLLOWING.

- (M5) -SUPER MULTIPLE JUNCTION (SMJ)
- (M1), (E203) -FUSE BLOCK-JUNCTION BOX (J/B) NO.1
- (M4), (B4) -ELECTRICAL UNITS

TIWM0728E

AUTOMATIC DRIVE POSITIONER

SE-AUT/DP-06

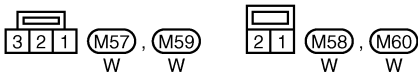
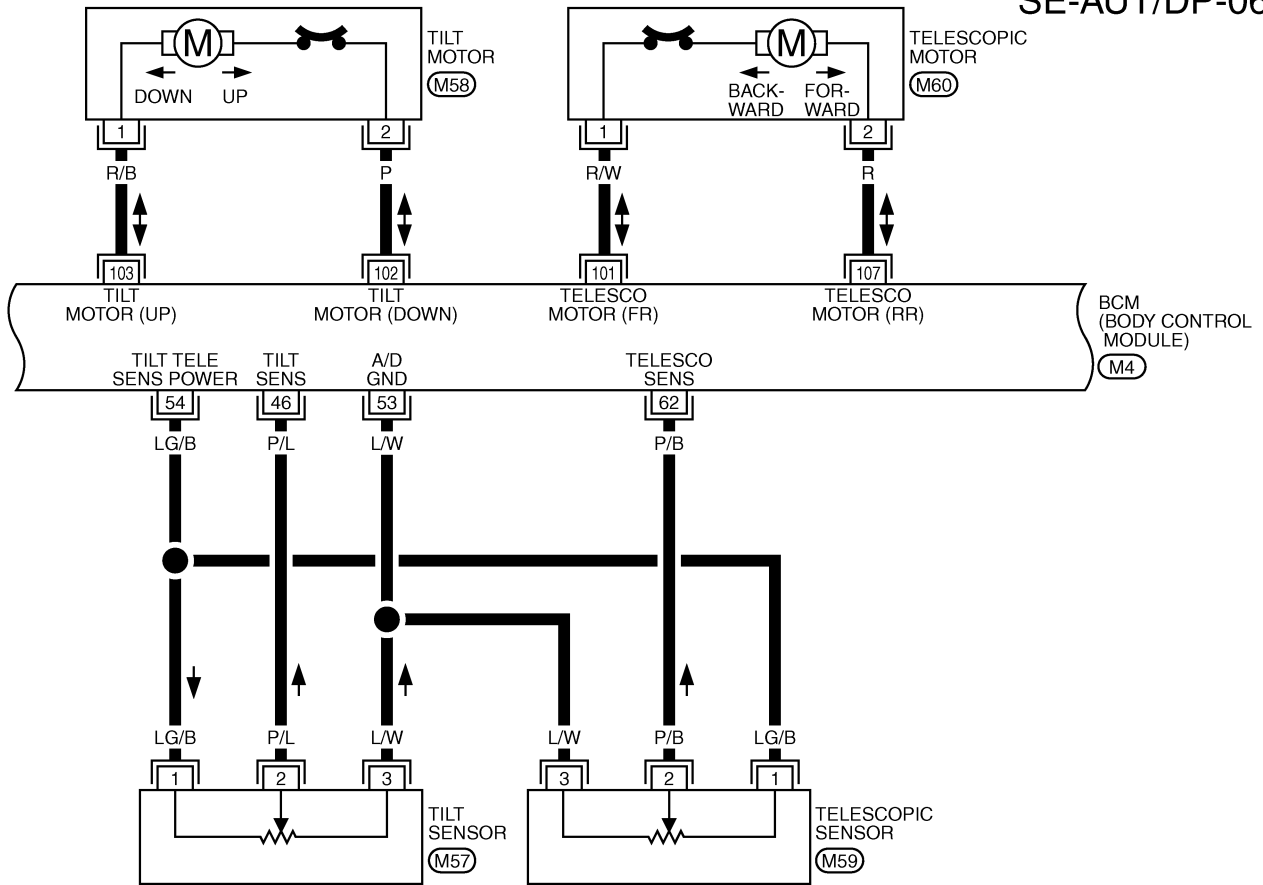

REFER TO THE FOLLOWING.
 (M4) -ELECTRICAL UNITS

TIWM0729E

AUTOMATIC DRIVE POSITIONER

SE-AUT/DP-07

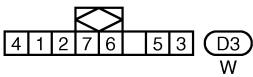
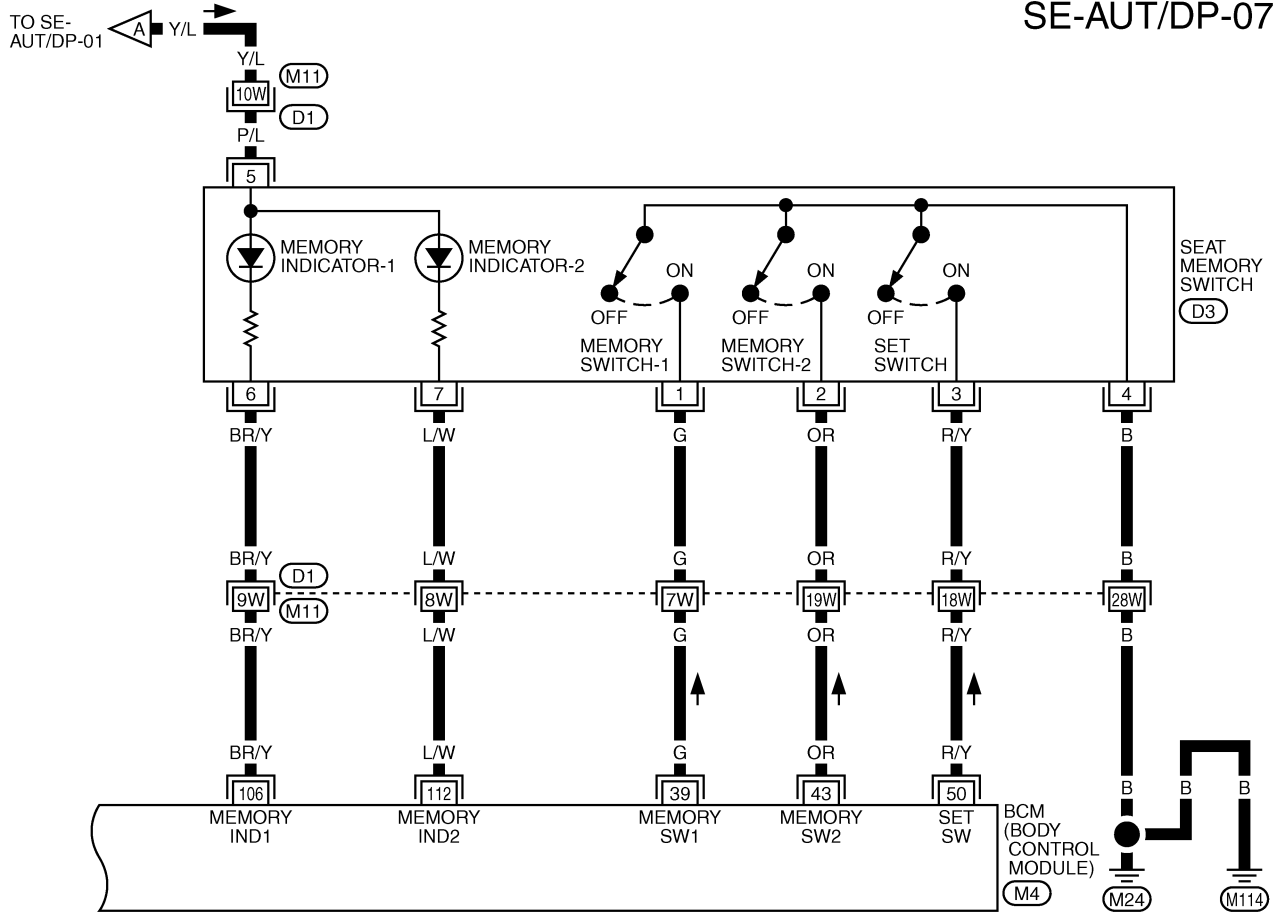

REFER TO THE FOLLOWING.

(D1) -SUPER MULTIPLE JUNCTION (SMJ)

(M4) -ELECTRICAL UNITS

TIWM0730E

AUTOMATIC DRIVE POSITIONER

SE-AUT/DP-08

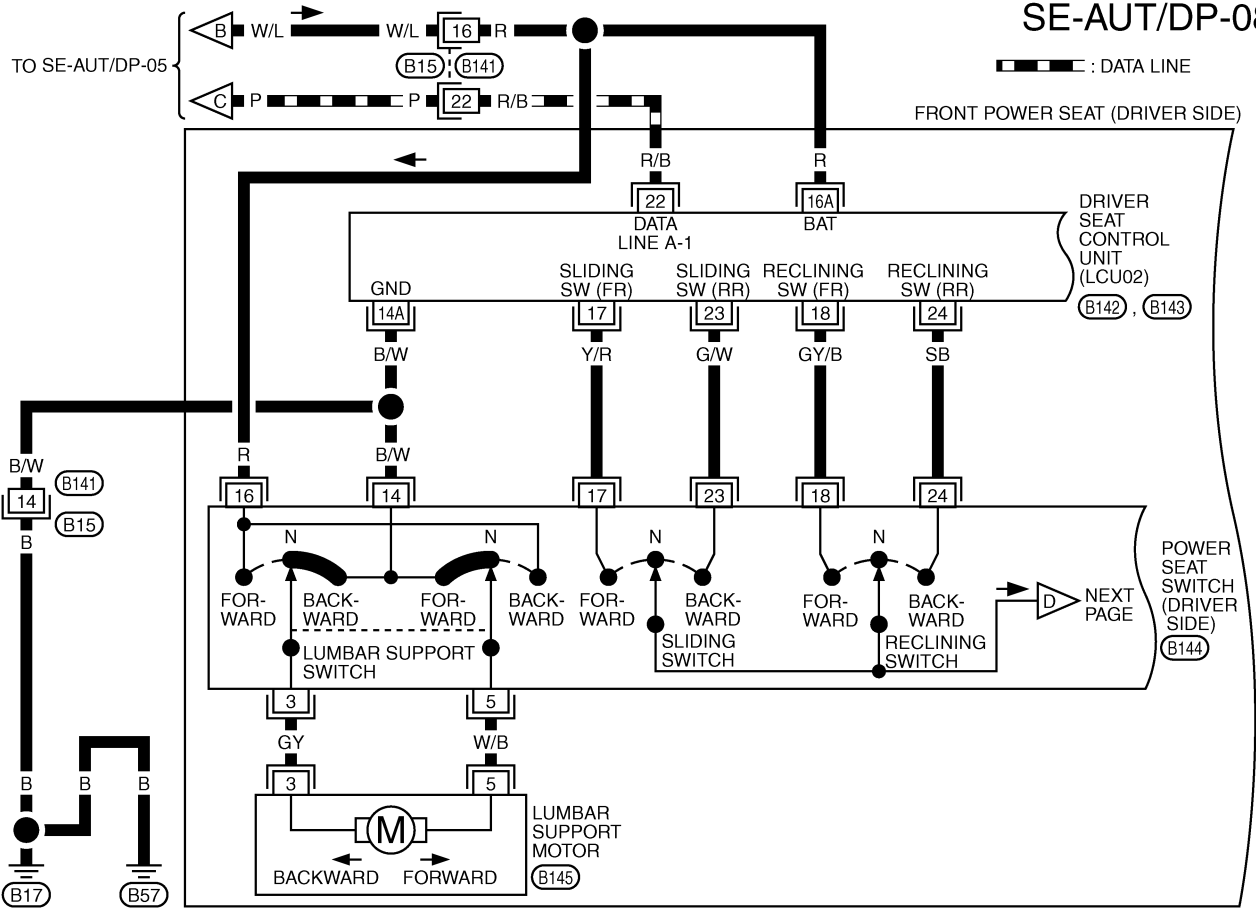

JD	16	L1	15	
63	62	41	14	JC

(B15)
W

8	4	6	2	1	*
16A	14A	15B	10	11	9

(B142)
W

23	22	21	20	19	18	17	*	
32	31	30	29	28	27	26	25	24

(B143)
W

17	18	15	16	14	3	*
23	24	25	19	27	26	5

(B144)
W

3	5	*
---	---	---

(B145)
B

*: THIS CONNECTOR IS NOT SHOWN IN "HARNES LAYOUT", PG SECTION.

TIWM0731E

AUTOMATIC DRIVE POSITIONER

SE-AUT/DP-09

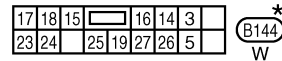
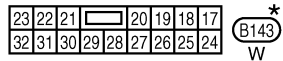
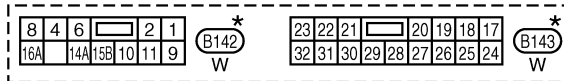
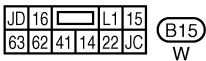
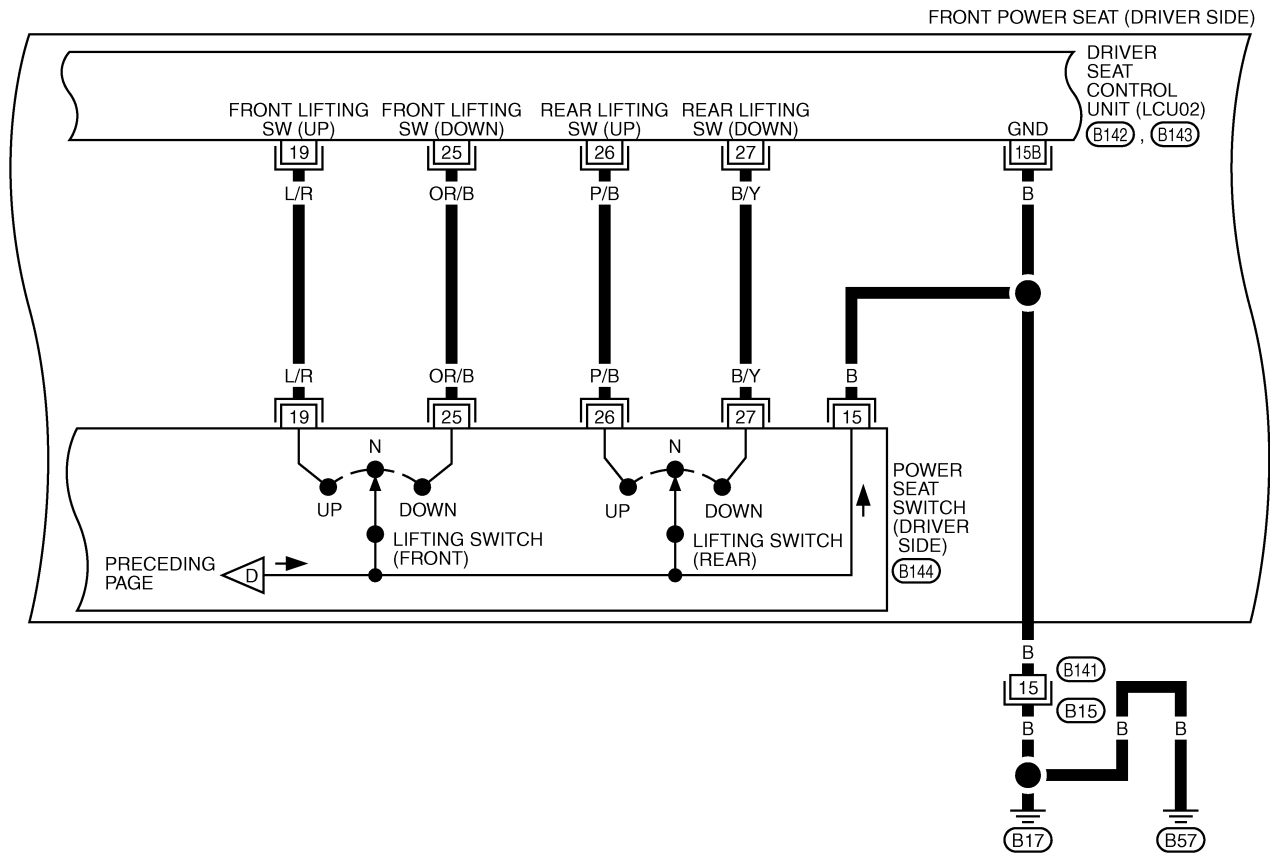

*: THIS CONNECTOR IS NOT SHOWN IN "HARNESS LAYOUT", PG SECTION.

TIVM0732E

AUTOMATIC DRIVE POSITIONER

SE-AUT/DP-10

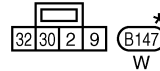
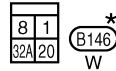
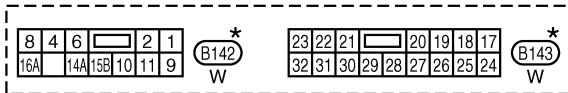
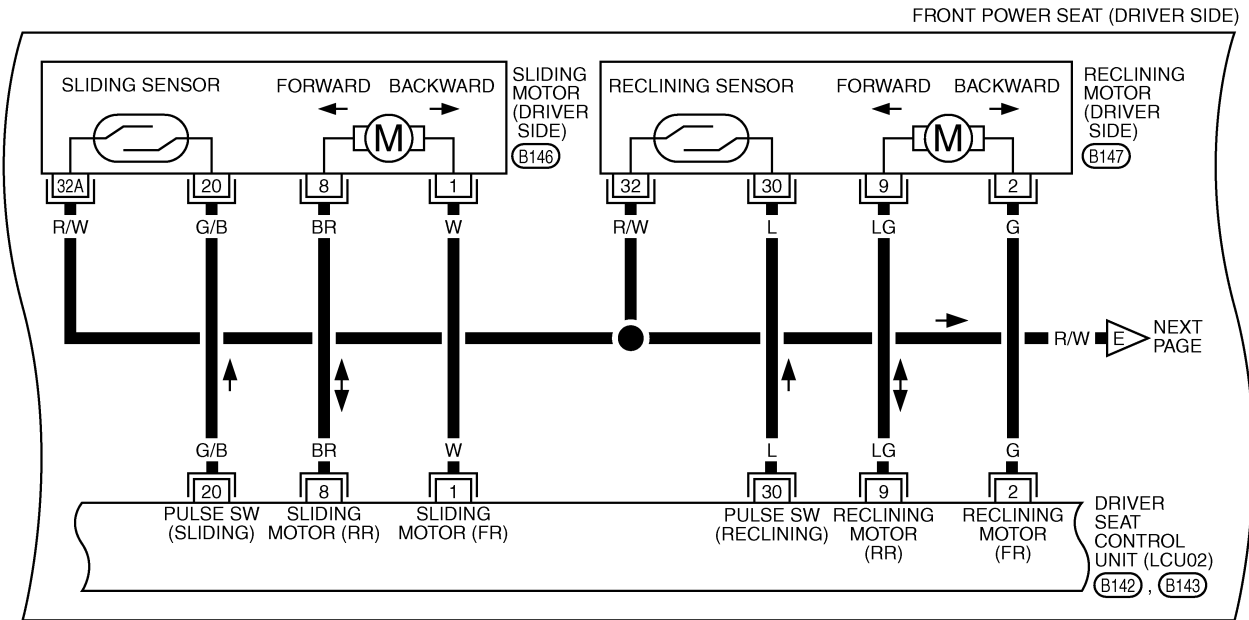

*: THIS CONNECTOR IS NOT SHOWN IN "HARNESS LAYOUT", PG SECTION.

TIWM0085E

A
B
C
D
E
F
G
H
J
K
L
M

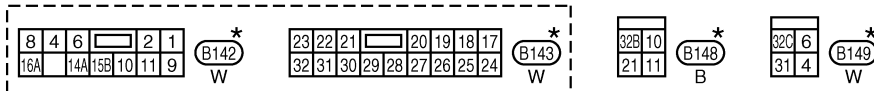
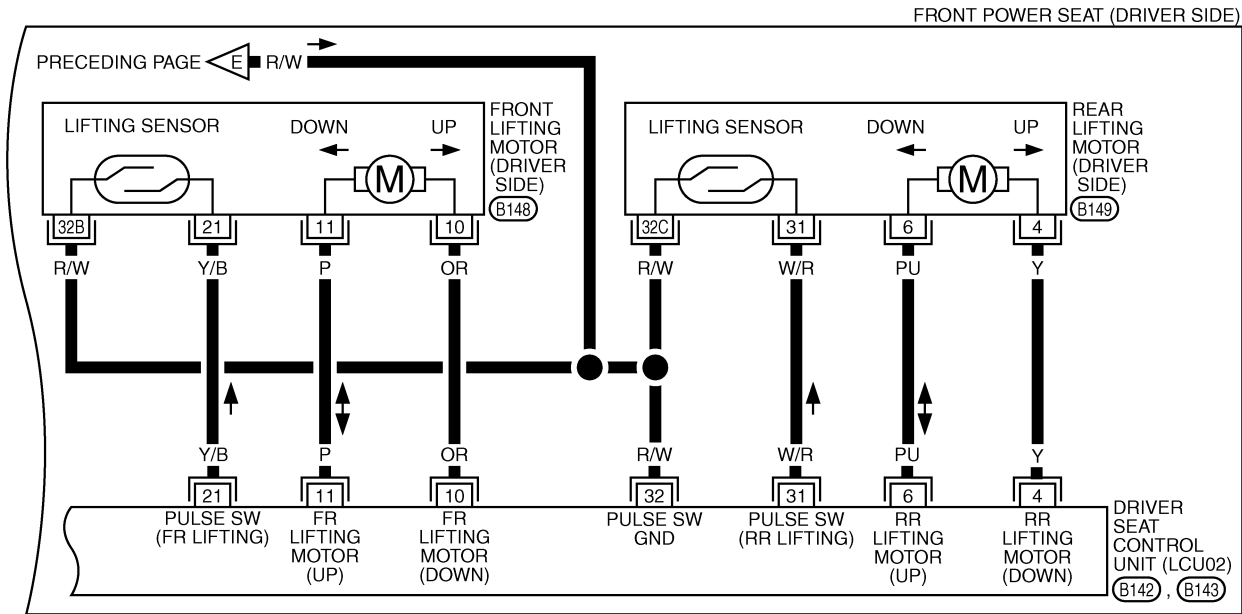

*: THIS CONNECTOR IS NOT SHOWN IN "HARNESS LAYOUT", PG SECTION.

TIVM0089E

AUTOMATIC DRIVE POSITIONER

Terminals and Reference Values for BCM

EIS008K3

Terminal	WIRE COLOR	ITEM	CONDITION		VOLTAGE (V) (Approx.)
8	G/OR	Detente switch signal	Insert the key	Selector lever in P-position.	0
				Selector lever in other than P-position.	Battery voltage
17	BR/Y	Data link (RX line)	—		—
18	P	Data link (TX line)	—		—
22	R	Telescopic switch FR signal	Telescoping switch	Forward operation (Motor operated)	0
				OFF	5
23	PU/W	Tilt switch DOWN signal	Tilt switch	DOWN operation (Motor operated)	0
				OFF	5
26	GY/R	Telescopic switch RR signal	Telescoping switch	Backward operation (Motor operated)	0
				OFF	5
30	PU	Monitor line (TX)	—		—
31	LG	Monitor line (RX)	—		—
36	Y/G	Tilt switch UP signal	Tilt switch	UP operation (Motor operated)	0
				OFF	5
39	G	Memory switch 1 signal	Memory switch 1	ON	0
				OFF	5
43	OR	Memory switch 2 signal	Memory switch 2	ON	0
				OFF	5
46	P/L	Tilt sensor signal	Tilt position, top		2
			Tilt position, bottom		4
49	PU/W	Vehicle speed signal (2-pulse)	When vehicle speed is approx. 40 km/h (25 MPH).		
50	R/Y	Seat memory setting switch signal	Setting switch	ON	0
				OFF	5
53	L/W	Tilt and telescopic sensor ground	Ignition switch ON		0
54	LG/B	Tilt and telescopic sensor power supply	—		5
55	B/W	Ignition switch (START)	Ignition switch (START position)		Battery voltage
56	B	Ground	—		0
60	L/OR	Ignition switch (ACC)	Ignition switch (ACC or ON position)		Battery voltage
61	R/B	Date line A-2	—		—
62	P/B	Telescopic sensor signal	Telescoping position, top		2
			Telescoping position, bottom		4

AUTOMATIC DRIVE POSITIONER

Terminal	WIRE COLOR	ITEM	CONDITION		VOLTAGE (V) (Approx.)
67	G/W	Date line A-3	—		—
68	W/B	Ignition switch (ON)	Ignition switch (ON or START position)		Battery voltage
69	PU/W	Key switch signal	Insert the key (ON).		Battery voltage
			Remove the key (OFF).		0
101	R/W	Telescopic motor FR signal	Telescoping switch	ON (forward operation)	Battery voltage
				OFF	0
102	P	Tilt motor DOWN signal	Tilt switch	ON (DOWN operation)	Battery voltage
				OFF	0
103	R/B	Tilt motor UP signal	Tilt switch	ON (UP operation)	Battery voltage
				OFF	0
104	Y/B	Power supply for tilt and telescopic device	—		Battery voltage
105	Y/L	Battery power supply	—		Battery voltage
106	BR/Y	Power seat memory indicator 1 signal	Indicator 1	ON	0
				OFF	Battery voltage
107	R	Telescopic motor RR signal	Telescoping switch	ON (backward operation)	Battery voltage
				OFF	0
112	L/W	Power seat memory indicator 2 signal	Indicator 2	ON	0
				OFF	Battery voltage
113	B	Ground	Ignition switch ON		0
114	B	Ground for tilt and telescoping device	Ignition switch ON		0
142	W/R	Driver door switch signal	Driver door open (ON)		0
			Driver door closed (OFF)		Battery voltage
148	P	Data line A-1	—		—

Terminals and Reference Values for Driver Seat Control Unit

E/IS008K4

TERMINAL	WIRE COLOR	ITEM	CONDITION		VOLTAGE (V) (Approx.)
1	W	Sliding motor FR output signal	Sliding switch	Forward operation (Motor operated)	Battery voltage
				OFF	0
2	G	Reclining motor FR output signal	Reclining switch	Forward operation (Motor operated)	Battery voltage
				OFF	0
4	Y	Rear lifting motor DOWN output signal	Rear lifting switch	DOWN operation (Motor operated)	Battery voltage
				OFF	0
6	PU	Rear lifting motor UP output signal	Rear lifting switch	UP operation (Motor operated)	Battery voltage
				OFF	0
8	BR	Sliding motor RR output signal	Sliding switch	Backward operation (Motor operated)	Battery voltage
				OFF	0

AUTOMATIC DRIVE POSITIONER

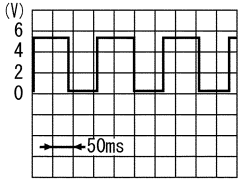
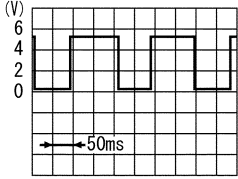
TERMI-NAL	WIRE COLOR	ITEM	CONDITION		VOLTAGE (V) (Approx.)
9	LG	Reclining motor RR output signal	Reclining switch	Backward operation (Motor operated)	Battery voltage
				OFF	0
10	OR	Front lifting motor DOWN signal	Front lifting switch	DOWN operation (Motor operated)	Battery voltage
				OFF	0
11	P	Front lifting motor UP output signal	Front lifting switch	UP operation (Motor operated)	Battery voltage
				OFF	0
14A	B/W	Ground	Ignition switch ON		0
15B	B				
16A	R	Battery power supply	—		Battery voltage
17	Y/R	Sliding switch FR signal	Sliding switch	ON (forward operation)	0
				OFF	5
18	GY/B	Reclining switch FR signal	Reclining switch	ON (forward operation)	0
				OFF	5
19	L/R	Front lifting switch UP signal	Front lifting switch	ON (UP operation)	0
				OFF	5
20	G/B	Sliding sensor signal	Sliding motor operation		 <p style="text-align: right; font-size: small;">S1IA0690J</p>
			Other than above.		0 or 5
21	Y/B	Front lifting sensor signal	Front lifting motor operation		 <p style="text-align: right; font-size: small;">S1IA0691J</p>
			Other than above.		0 or 5
22	R/B	Data line A-1	—		—
23	G/W	Sliding switch RR signal	Sliding switch	ON (backward operation)	0
				OFF	0 or 5
24	SB	Reclining switch RR signal	Reclining switch	ON (backward operation)	0
				OFF	0 or 5
25	OR/B	Front lifting switch DOWN signal	Front lifting switch	ON (DOWN operation)	0
				OFF	0 or 5
26	P/B	Rear lifting switch UP signal	Rear lifting switch	ON (UP operation)	0
				OFF	0 or 5

AUTOMATIC DRIVE POSITIONER

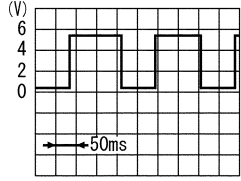
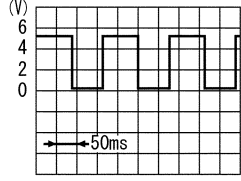
TERMI-NAL	WIRE COLOR	ITEM	CONDITION		VOLTAGE (V) (Approx.)
27	B/Y	Rear lifting switch DOWN signal	Rear lifting switch	ON (DOWN operation)	0
				OFF	0 or 5
30	L	Reclining sensor signal	Reclining motor operation		 SIIA0692J
			Other than above.		0 or 5
31	W/R	Rear lifting sensor signal	Rear lifting motor operation		 SIIA0693J
			Other than above.		0 or 5
32	R/W	Ground (sensor)	Ignition switch ON		0

Work Flow

EIS008K5

1. Check the symptom and customer's requests.
2. Understand the system description. Refer to [SE-13, "System Description"](#).
3. Perform the preliminary check. Refer to [SE-36, "Preliminary Check"](#).
4. Perform the communication diagnosis.
 With CONSULT-II, Refer to [SE-40, "IVMS Communication Diagnosis"](#).
 Without CONSULT-II, refer to [SE-47, "COMMUNICATION DIAGNOSIS"](#).
 Is the communication diagnosis result OK?
 If OK, GO TO 7.
 If NG, GO TO 5.
5. Repair or replace depending on the diagnosis result.
6. Perform the communication diagnosis again.
 With CONSULT-II, refer to [SE-40, "IVMS Communication Diagnosis"](#).
 Without CONSULT-II, refer to [SE-47, "COMMUNICATION DIAGNOSIS"](#).
 Is the communication diagnosis result OK?
 If OK, GO TO 7.
 If NG, GO TO 5.
7. Perform the self-diagnosis.
 With CONSULT-II, refer to [SE-43, "SELF-DIAGNOSIS RESULTS"](#).
 Without CONSULT-II, refer to [SE-51, "ON BOARD DIAGNOSIS FOR AUTOMATIC DRIVE POSITIONER"](#).
 Is the self-diagnosis result OK?
 If OK, GO TO 11.
 If NG, GO TO 8.
8. Repair or replace depending on the self-diagnosis result.
9. Perform the self-diagnosis again.
 With CONSULT-II, refer to [SE-43, "SELF-DIAGNOSIS RESULTS"](#).
 Without CONSULT-II, refer to [SE-51, "ON BOARD DIAGNOSIS FOR AUTOMATIC DRIVE POSITIONER"](#).
 Is the self-diagnosis result OK?
 If OK, GO TO 11.
 If NG, GO TO 8.

AUTOMATIC DRIVE POSITIONER

10. Based on the trouble diagnosis chart, repair or replace the cause of the malfunction. Refer to [SE-53, "Symptom Chart"](#).
11. Does the automatic drive positioned system operate normally?
If it is normal, GO TO 12.
If it is not normal, GO TO 4.
12. Inspection end.

Preliminary Check SETTING CHANGE FUNCTION

E/S008K6

The settings of the automatic driving position system can be changed, using CONSULT-II and the display unit in the center of the instrument panel.

Setting item	Content	CONSULT-II (WORK SUPPORT)	Display unit	Factory setting
EXITING OPERATION PART SET	The applied parts at exit can be selected from the following 4 modes.	Mode 1 Steering wheel and seat	—	×
		Mode 2 Steering wheel only		—
		Mode 3 Seat only		—
		Mode 4 No operation		—
Tilt Steering Wheel When Exiting Vehicle	Tilt of the steering wheel at entry and exit can be selected: ON (operated)–OFF (not operated)	—	ON: Indicator lamp ON	×
			OFF: Indicator lamp OFF	—
Sliding Driver Seat When Entry / Exiting Vehicle	The seat sliding turnout and return at entry/exit can be selected: ON (operated)–OFF (not operated)	—	ON: Indicator lamp ON	×
			OFF: Indicator lamp OFF	—

×: Applicable –: Not applicable

NOTE:

After the setting is registered, the new setting is effective, even if the battery is disconnected.

POWER SUPPLY AND GROUND CIRCUIT INSPECTION

1. CHECK FUSE

Check that any of the following fuses in the BCM are blown.

Unit	Signal name	Fuse No.	Location	
BCM	Battery power	H (40A)	Fuse, fusible link and relay block (J/B)	
		3 (10A)		
	ACC or ON power supply	21 (10A)		Fuse block (J/B) No.1
	START power supply	14 (10A)		
ON or START power supply	1 (10A)			

NOTE:

Refer to [SE-17, "Component Parts and Harness Connector Location"](#).

OK or NG

OK >> GO TO 2.

NG >> If fuse is blown, be sure to eliminate cause of problem before installing new fuse. Refer to [PG-2, "POWER SUPPLY ROUTING"](#).

AUTOMATIC DRIVE POSITIONER

2. CHECK POWER SUPPLY CIRCUIT (BCM)

Check voltage between BCM connector and ground.

Connector	Terminals (Wire color)		Condition	Voltage (V) (Approx.)
	(+)	(-)		
M4	104 (Y/B), 105 (Y/L)	Ground	Ignition switch OFF	Battery voltage
	60 (L/OR)		Ignition switch ACC or ON	
	55 (B/W)		Ignition switch START	
	68 (W/B)		Ignition switch ON or START	

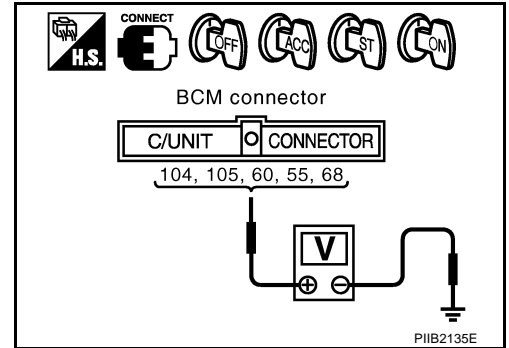

OK or NG

OK >> GO TO 3.

NG >> Check harness for open and short between BCM and fuse.

3. GROUND CIRCUIT INSPECTION (BCM).

- Turn ignition switch OFF.
- Disconnect BCM connector.
- Check continuity between BCM connector M4 terminal 56 (B), 113 (B), 114 (B) and ground.

56 (B) – Ground :Continuity should exist.

113 (B) – Ground :Continuity should exist.

114 (B) – Ground :Continuity should exist.

OK or NG

OK >> BCM circuit is OK. Check the driver seat control unit.
GO TO 4.

NG >> Repair or replace the harness between BCM and ground.

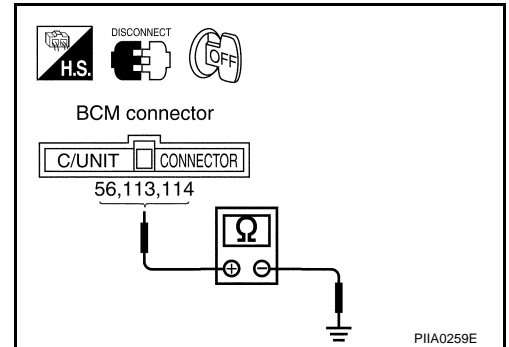

4. CHECK POWER SUPPLY CIRCUIT (DRIVER SEAT CONTROL UNIT)

Check voltage between driver seat control unit connector B142 terminal 16A (R) and ground.

16A (R) – Ground :Battery voltage.

OK or NG

OK >> GO TO 5.

NG >> Repair or replace harness between driver seat control unit and fuse block (J/B) No. 1.

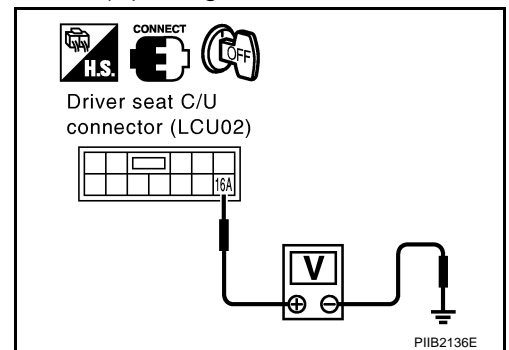

AUTOMATIC DRIVE POSITIONER

5. CHECK GROUND CIRCUIT (DRIVER SEAT CONTROL UNIT)

1. Turn ignition switch OFF.
2. Disconnect driver seat control unit connector.
3. Check continuity between the driver seat control unit connector B142 terminal 14A (B/W), 15B (B) and ground.

14A (B/W) – Ground :Continuity should exist.

15B (B) – Ground :Continuity should exist.

OK or NG

OK >> Driver seat control unit circuit is OK.

NG >> Repair or place harness between driver seat control unit (LCU 02) and ground.

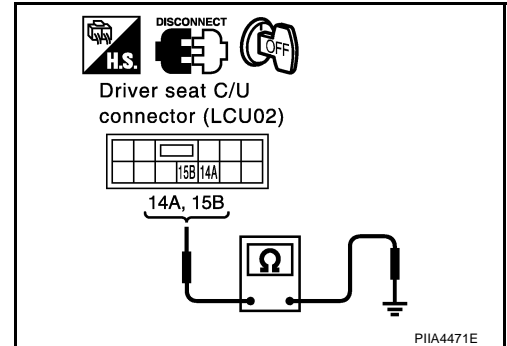

AUTOMATIC DRIVE POSITIONER

CONSULT-II Function

E/S008K7

CONSULT-II executes the following functions by combining data received and transmits command transmission via the communication line from the BCM. IVMS communication inspection, work support by part, self-diagnosis, data monitor, and active test display.

IVMS diagnosis items	Inspection item, self-diagnosis mode	Content
IVMS – COMM CHECK	IVMS– COMM DIAGNOSIS	Diagnoses a communication malfunction, inactive communication, and sleep malfunction in the communication line between the BCM and each LCU.
	WAKE– UP DIAGNOSIS	Diagnoses the wake-up signals output from each LCU.
AUTO DRIVE POSITIONER	WORK SUPPORT*	Changes the setting for each function.
	SELF– DIG RESULTS	Perform the self-diagnosis.
	DATA MONITOR	Displays the input data of the BCM and each LCU on real-time basis.
	ACTIVE TEST	Gives a drive signal to a load to check the operation.
BCM PART NUMBER		Displays BCM part No.

*: For setting seat and steering functions only.

CONSULT-II BASIC OPERATION PROCEDURE

1. Turn ignition switch “OFF”.
2. Connect “CONSULT-II” and CONSULT-II CONVERTER to data link connector.

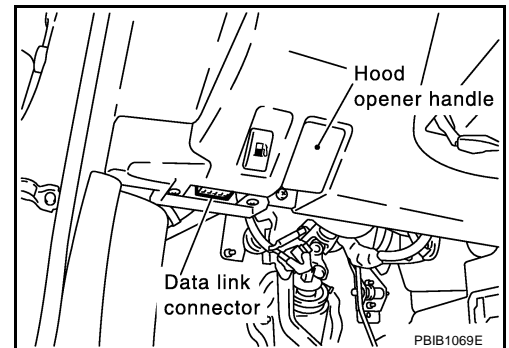

3. Turn ignition switch “ON”.
4. Touch “START(NISSAN BASED VHCL)”.

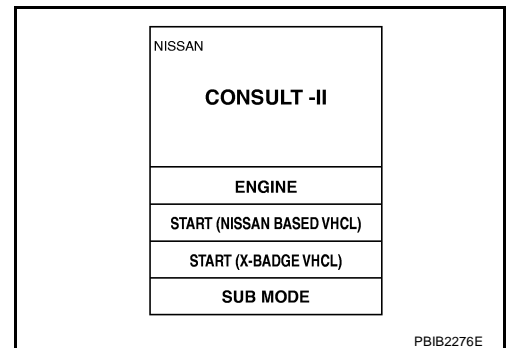

5. Touch “IVMS” on the “SELECT SYSTEM” screen. If “IVMS” is not indicated, [GI-38, "CONSULT-II Data Link Connector \(DLC\) Circuit"](#) .

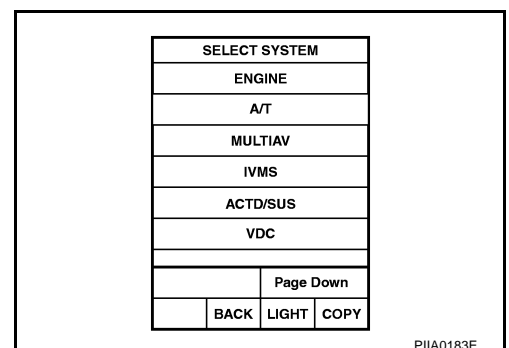

AUTOMATIC DRIVE POSITIONER

6. Check the model specification, and touch either "WITH SUNROOF" or "WITHOUT SUNROOF" on the "SELECT SYS COND" screen.
7. Touch "OK". If the selection is wrong, touch "CANCEL".
8. Select the desired part to be diagnosed on the "SELECT TEST ITEM" screen.

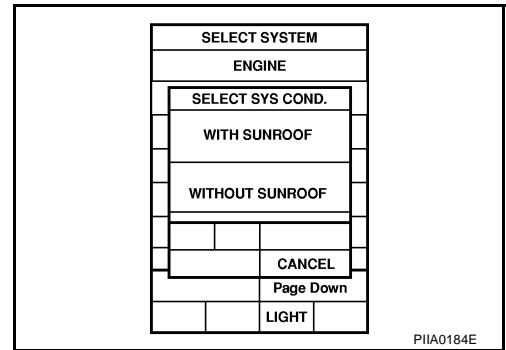

IVMS COMMUNICATION INSPECTION.

IVMS contains the IVMS communication diagnosis and wake-up diagnosis.

IVMS Communication Diagnosis

- The function also stores the communication malfunction records and inactive communication records, and displays the data on the CONSULT-II screen. (malfunction record diagnosis.)

NOTE:

Sleep is a power saving function when a vehicle is stationary (all BCM related electrical equipment: OFF, and the timer: OFF).

Malfunction	CONSULT-II display item	Diagnosis content
Communication malfunction	COMM DATA	Communicating with each LCU is judged normal when communication is normally completed and when both transmitted data and received data are equal. In other cases, it is judged malfunctioning. If the communication is inactive, no diagnosis result is displayed.
Inactive communication	NO RESPONSE	Communicating with each LCU is judged normal when at least 1 communication is normally completed within 3 trials. In other cases, it is judged malfunctioning.
Sleep malfunction	SLEEP	Check that each LCU switches to sleep mode.
Communication malfunction*	PAST COMM DATA	The records when communication signal, malfunctions were continuously detected while the communication was normal are displayed, or a malfunction was detected during the sleep control in the past are displayed.
Inactive communication*	PAST NO RESPONSE	The records when inactive communications were continuously detected while the communication was normal are displayed.

*: Malfunction item record

Operation Procedure

1. Touch "IVMS-COMM CHECK" on "SELECT TEST ITEM".
2. Touch "IVMS-COMM DIAGNOSIS" on the "SELECT DIAG ITEM" screen.
3. Touch "START" on the "IVMS-COMM DIAGNOSIS" screen to start the diagnosis.
4. After the diagnosis is completed, the malfunctioning system name is displayed.
5. When the malfunctioning items are displayed, touch "PRINT" to keep the records.
6. Touch "ERASE".
7. Carry out the communication inspection again to check that any malfunctioning item is displayed.
8. Check the displayed items.

Wake-up Diagnosis.

The wake-up diagnosis is carried out when the BCM detects the wake-up signal from each local control unit (LCU). When the switch shown on the screen is operated as instructed, each local control unit (LCU) outputs the wake-up signal. If the BCM cannot detect the wake-up signal, it is judged malfunctioning. The malfunctioning local control unit (LCU) is displayed on the screen.

Operation Procedure

1. Touch "IVMS-COMM CHECK" on the "SELECT TEST ITEM" screen.
2. Touch "WAKE-UP DIAGNOSIS" on the "SELECT DIAG ITEM" screen.
3. Touch "START" on the "WAKE-UP DIAGNOSIS" screen to start the diagnosis.

AUTOMATIC DRIVE POSITIONER

4. Touch "NEXT" to select the local control unit (LCU) to be diagnosed.
5. Check that any malfunction is displayed. If necessary, touch "PRINT" to keep the record.
6. Carry out the inspection of the malfunctioning item.

Trouble Diagnosis Chart

Malfunctioning item	Display unit	CONSULT-II IVMS communication diagnosis content	Self-diagnosis trouble code No.	Malfunctioning system and reference
COMM DATA	One LCU is displayed.	POWER WINDOW C/U-DR "COMMDATA"	24	Replace the displayed LCU.
		DOOR MIRROR C/U-RH "COMMDATA"	27	
		DOOR MIRROR C/U-LH "COMMDATA"	37	
		POWER SEAT C/U-DR "COMMDATA"	47	
	Multiple LCU are displayed.	BCM "COMMFAL1", "COMMFAL2"	Displays in order of 24 →27→37→47 →and cycles from 24.	Communication system A: Refer to SE-41 .
NO RESPONSE	One LCU is displayed.	POWER WINDOW C/U-DR "NORESPONSE"	25	Communication system B: Refer to SE-42
		DOOR MIRROR C/U-RH "NORESPONSE"	28	
		DOOR MIRROR C/U-LH "NORESPONSE"	38	
		POWER SEAT C/U-DR "NORESPONSE"	48	
	Multiple LCU are displayed.	BCM/HARNESS	Displays in order of 25→28→38→48 and cycles from 25.	Communication system C: Refer to SE-42 .
SLEEP malfunction	One LCU is displayed.	POWER WINDOW C/U-DR "SLEEP"	No self-diagnosis function	Replace the displayed LCU.
		DOOR MIRROR C/U-RH "SLEEP"		
		DOOR MIRROR C/U-LH "SLEEP"		
		POWER SEAT C/U-DR "SLEEP"		
	Multiple LCU are displayed.	All the above control units are displayed.	No self-diagnosis function	Communication system A: Refer to SE-41 .

NOTE:

- For a specific local control unit (LCU), either "PAST COMM DATA" or "PAST NO RESPONSE" may be displayed instead of the above results. The data record, causes this, so erase the records.
(The display only shows the incident records, they are not malfunctions caused during the diagnosis. One possible cause is that an intermittent incident occurred.)
- Follow the steps below to erase the memory.
Carry out either disconnect BCM battery power supply or erase memory with CONSULT-II.
- With the battery connected, if the local control unit (LCU) connector is disconnected and left for approximately 1 minute, the BCM stores "NO RESPONSE" record.

COMMUNICATION SYSTEM A

1. CHECK BCM

Replace the BCM with a known-good one, and carry out the communication diagnosis. Refer to [SE-40, "IVMS Communication Diagnosis"](#) .

OK or NG

- OK >> The harness and connector is checked, and it is normal, replace BCM
 NG >> GO TO 2.

AUTOMATIC DRIVE POSITIONER

2. CHECK LCU

1. Replace with the previously installed BCM.
2. Replace the LCU with a known-good one, and carry out the communication diagnosis. Refer to [SE-40, "IVMS Communication Diagnosis"](#) .

OK or NG

- OK >> The harness and connector is checked, and it is normal, replace LCU
NG >> Repair or replace harness between the LCU and BCM.

COMMUNICATION SYSTEM B

1. CHECK HARNESS CONNECTOR

Check terminals (at the control unit and harness) on the malfunctioning LCU for disconnection, bend, loose connection, and other malfunctions.

OK or NG

- OK >> GO TO 2.
NG >> Repair the terminals and connectors.

2. CHECK LCU

Replace the malfunctioning LCU with a known-good one, and carry out the communication diagnosis. Refer to [SE-40, "IVMS Communication Diagnosis"](#) .

OK or NG

- OK >> The harness and connector is checked, and it is normal, replace LCU
NG >> Repair the harness between the indicated LCU and BCM.

COMMUNICATION SYSTEM C

1. CHECK HARNESS CONNECTOR

Check terminals (at the control unit and harness) on BCM and LCU for disconnection, bend, loose connection, and other malfunctions.

OK or NG

- OK >> GO TO 2.
NG >> Repair the terminals and connectors.

2. CHECK BCM

Replace the malfunctioning BCM with a known-good one, and carry out the communication diagnosis. Refer to [SE-40, "IVMS Communication Diagnosis"](#) .

OK or NG

- OK >> The harness and connector is checked, and it is normal, replace BCM
NG >> Repair the harness between the LCU and BCM control.

AUTOMATIC DRIVE POSITIONER

WORK SUPPORT

Display Item List

Refer to [SE-36, "SETTING CHANGE FUNCTION"](#) .

SELF-DIAGNOSIS RESULTS

Display Item List

Malfunctioning system	Malfunction detecting condition	Diagnostic procedure	Reference page
SEAT SLIDE	When the sliding sensor pulse changes 2 times or less, while the sliding motor moves the seat backward for 2.5 seconds, and then forward for 2.5 seconds.	Sliding motor circuit check Sliding sensor circuit check	SE-55 SE-64
SEAT RECLINING	When the reclining sensor pulse changes 2 times or less, while the reclining motor moves the seat forward for 2.5 seconds, and then backward for 2.5 seconds.	Reclining motor circuit check Reclining sensor circuit check	SE-56 SE-65
SEAT LIFTER-FR	When the lifter sensor (front end) pulse changes 2 times or less, while the lifter motor (front end) moves the seat downward for 2.5 seconds, and then upward for 2.5 seconds.	Front lifting motor circuit check Front lifting sensor circuit check	SE-57 SE-66
SEAT LIFTER-RR	When the lifter sensor (rear end) pulse changes 2 times or less, while the lifter motor (rear end) moves the seat downward for 2.5 seconds, and then upward for 2.5 seconds.	Rear lifting motor circuit check Rear lifting sensor circuit check	SE-59 SE-67
STEERING TILT	,When the tilt sensor output voltage is 0.2V or less, while the tilt motor moves the steering wheel upward for 1 second, and then downward for 1 second.	Tilt motor circuit check Tilt sensor circuit check	SE-62 SE-70
STEERING TELESCO	When the telescoping sensor output voltage is 0.2V or less, while the telescope motor moves the steering wheel forward for 1 second, and then backward for 1 second,	Telescopic motor circuit check Telescopic sensor circuit check	SE-60 SE-69
DOOR MIRROR-LH-UP-DOWN	When LH door mirror sensor detects 0.2V or lower, or 4.5V or higher, for 0.5 seconds or more.	Mirror sensor circuit check	GW-114
DOOR MIRROR-LH-L-R			
DOOR MIRROR-RH-UP-DOWN	When RH door mirror sensor detects 0.2V or lower, or 4.5V or higher, for 0.5 seconds or more.	Mirror sensor circuit check	GW-114
DOOR MIRROR-RH-L-R			
VEHICLE SPEED SENSOR	When the vehicle speed is less than 7 km/h (4 MPH) for 15 seconds after the diagnosis for the seat and steering wheel is completed.	Vehicle speed signal check	SE-75

A
B
C
D
E
F
G
H
SE
J
K
L
M

AUTOMATIC DRIVE POSITIONER

Auto Drive Positioner Incident Memory

It stores the incident records of the input/output system related to the auto driving position system, and displays them on the CONSULT-II screen.

Malfunctioning system	Malfunction detecting condition	Diagnostic procedure	Reference page
SEAT SLIDE "PAST OUTPUT FAIL"	If the following conditions are met, the seat sliding output system is judged malfunctioning. If there is no manual input in the past or any auto operation output, and then within 2.5 seconds the sliding sensor receives an input signal showing that the seat has slid by 6 mm or more.	Sliding motor circuit check Sliding sensor circuit check	SE-55 SE-64
SEAT RECLINING "PAST OUTPUT FAIL"	If the following conditions are met, the seat reclining output system is judged malfunctioning. If there is no manual input in the past nor any auto operation output, and then within 2.5 seconds the reclining sensor receives an input signal showing that the seat has reclined by 2.22 or more.	Reclining motor circuit check Reclining sensor circuit check	SE-56 SE-65
STEERING TILT "PAST OUTPUT FAIL"	If the following conditions are met, the steering tilt output system is judged malfunctioning. If there is no manual input in the past nor any auto operation output, and then within 2.5 seconds the steering tilt sensor receives an input signal showing that the steering wheel is tilted by 1° or more.	Tilt motor circuit check Tilt sensor circuit check	SE-62 SE-70
DETENTION SW "PAST INPUT FAIL"	With the A/T selector lever in P-position (Detention switch OFF), if the vehicle speed of 7 km/h (4 MPH) or higher was input for at least 2 seconds, the detention switch input system is judged malfunctioning.	Detention switch circuit check	SE-68
TELESCO SENSOR "PAST"	If the voltage value detected by the telescopic sensor was 0.1V or less, or 4.9 V or more, the telescoping sensor is judged malfunctioning.	Telescopic sensor circuit check	SE-69
TILT SENSOR "PAST"	If the voltage value detected by the tilt sensor was 0.1V or less, or 4.9 V or more, the tilt sensor is judged malfunctioning.	Tilt sensor circuit check	SE-70

DATA MONITOR

Display Item List

Monitor item [OPERATION or UNIT]	Contents
SLIDE SW-FR	"ON/OFF" ON/OFF status judged from the sliding switch (FR) signal is displayed.
SLIDE SW-RR	"ON/OFF" ON/OFF status judged from the sliding switch (RR) signal is displayed.
RECLIN SW-FR	"ON/OFF" ON/OFF status judged from the reclining switch (FR) signal is displayed.
RECLIN SW-RR	"ON/OFF" ON/OFF status judged from the reclining switch (RR) signal is displayed.
LIFT FR SW-UP	"ON/OFF" ON/OFF status judged from the FR lifter switch (UP) signal is displayed.
LIFT FR SW-DN	"ON/OFF" ON/OFF status judged from the FR lifter switch (DOWN) signal is displayed.
LIFT RR SW-UP	"ON/OFF" ON/OFF status judged from the RR lifter switch (UP) signal is displayed.
LIFT RR SW-DN	"ON/OFF" ON/OFF status judged from the RR lifter switch (DOWN) signal is displayed.
MIR CON SW-UP	"ON/OFF" ON/OFF status judged from the door mirror remote control switch (UP) signal is displayed.
MIR CON SW-DN	"ON/OFF" ON/OFF status judged from the door mirror remote control switch (DOWN) signal is displayed.
MIR CON SW-RH	"ON/OFF" ON/OFF status judged from the door mirror remote control switch (RIGHT) signal is displayed.

AUTOMATIC DRIVE POSITIONER

Monitor item [OPERATION or UNIT]		Contents
MIR CON SW-LH	"ON/OFF"	ON/OFF status judged from the door mirror remote control switch (LEFT) signal is displayed.
MIR CHNG SW-R	"ON/OFF"	ON/OFF status judged from the door mirror remote control switch (switching to RIGHT) signal is displayed.
MIR CHNG SW-L	"ON/OFF"	ON/OFF status judged from the door mirror remote control switch (switching to LEFT) signal is displayed.
SET SW	"ON/OFF"	ON/OFF status judged from the setting switch signal is displayed.
TELESCO SW-FR	"ON/OFF"	ON/OFF status judged from the telescoping switch (FR) signal is displayed.
TELESCO SW-RR	"ON/OFF"	ON/OFF status judged from the telescoping switch (RR) signal is displayed.
TILT SW-UP	"ON/OFF"	ON/OFF status judged from the tilt switch (UP) signal is displayed.
TILT SW-DOWN	"ON/OFF"	ON/OFF status judged from the tilt switch (DOWN) signal is displayed.
MEMORY SW1	"ON/OFF"	ON/OFF status judged from the seat memory switch 1 signal is displayed.
MEMORY SW2	"ON/OFF"	ON/OFF status judged from the seat memory switch 2 signal is displayed.
CANCEL SW	"ON/OFF"	Setting status is displayed with the display unit: "Active (ON)/inactive (OFF)"
DOOR SW DR	"ON/OFF"	ON (Door open) / OFF (door closed) status judged from the driver door switch is displayed.
VHCL SPEED SE	"7km/7km"	The present vehicle speed (less than 7 km/h (4 MPH), or 7 km/h (4 MPH) or higher) is displayed.
DETENT SW	"ON/OFF"	The selector lever position "ON (P position) / OFF (other than P position)" judged from the detention switch signal is displayed.
IGN ON SW	"ON/OFF"	Ignition key switch ON (IGN ON)/OFF (ignition switch START, ACC, or OFF) status judged from the ignition switch signal is displayed.
IGN ACC SW	"ON/OFF"	Ignition key switch ON (ACC or IGN ON)/ OFF (ignition switch START, or OFF) status judged from the ignition switch signal is displayed.
IGN START SW	"ON/OFF"	Ignition key switch ON (START, ON) /OFF (ignition switch IGN, ACC, or OFF) status judged from the ignition switch signal is displayed.
IGN KEY SW	"ON/OFF"	Key inserted (ON)/key removed (OFF) status judged from the key detection switch is displayed.
R POSITION SW	"ON/OFF"	R position (ON)/Other than R position of shift position signal from back-up lamp relay is displayed.
TILT SEN	"V"	The tilt position (voltage) judged from the tilt sensor signal is displayed.
TELESCO SEN	"V"	The telescoping position (voltage) judged from the telescoping sensor signal is displayed.
MIR/SE RH R-L	"ON/OFF"	ON (normal value)/OFF (abnormal value) *of voltage value judged from RH door mirror sensor output voltage (LH/RH) is displayed.
MIR/SE RH U-D	"ON/OFF"	ON (normal value)/OFF (abnormal value) *of voltage value judged from RH door mirror sensor output voltage (UP/DOWN) is displayed.
MIR/SE LH R-L	"ON/OFF"	ON (normal value)/OFF (abnormal value) *of voltage value judged from LH door mirror sensor output voltage (LH/RH) is displayed.
MIR/SE LH U-D	"ON/OFF"	ON (normal value)/OFF (abnormal value) *of voltage value judged from LH door mirror sensor output voltage (UP/DOWN) is displayed.

*: Abnormal value indicates that the sensor output voltage is 0.2V or lower, or 4.5V or higher.

ACTIVE TEST

Display Item List

Test item	Description
TILT MOTOR	The tilt motor is activated by receiving the drive signal.
TELESCO MOTOR	The telescopic motor is activated by receiving the drive signal.
SEAT SLIDE	The sliding motor is activated by receiving the drive signal.
SEAT RECLINING	The reclining motor is activated by receiving the drive signal.

AUTOMATIC DRIVE POSITIONER

Test item	Description
SEAT LIFTER FR	The front end lifter motor is activated by receiving the drive signal.
SEAT LIFTER RR	The rear end lifter motor is activated by receiving the drive signal.
MEMORY SW INDCTR	The memory switch indicator is lit by receiving the drive signal.
MIRROR MOTOR RH	The RH mirror motor moves the mirror UP/DOWN and LEFT/RIGHT by receiving the drive signal.
MIRROR MOTOR LH	The LH mirror motor moves the mirror UP/DOWN and LEFT/RIGHT by receiving the drive signal.

On Board Diagnosis

E/S008K8

BCM can check each local unit (LCU), switches, loads, and malfunctions in communication with the self-diagnosis.

DIAGNOSIS ITEM

Diagnosis item	Description
Communication diagnosis	It can check the communication line between BCM and each LCU, and also each LCU, for a communication malfunction.
Switch monitor	It can check the switch systems which send data to BCM and each LCU for a malfunction.
Self-diagnosis for auto drive positioner	Diagnosis malfunctions in each motor and sensor in the electrical load parts of the driver power seat system (sliding, reclining, and lifter [front/rear]), of the steering wheel system (tilt, telescoping), and of door mirror.

AUTOMATIC DRIVE POSITIONER

COMMUNICATION DIAGNOSIS

Check the communication between BCM and each local control unit (LCU).

Operation Procedure

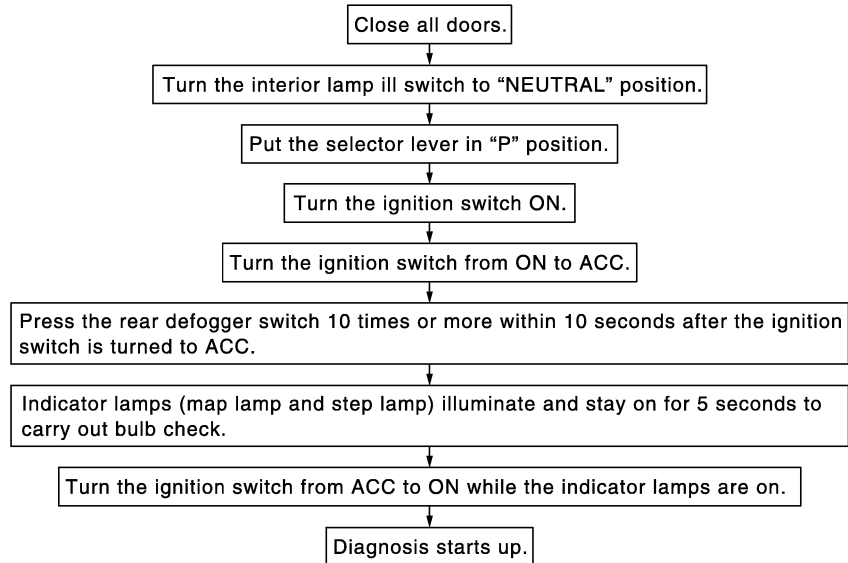
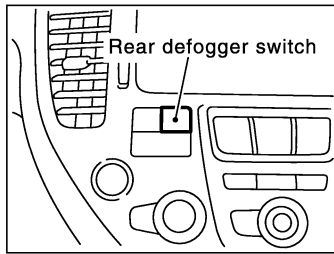
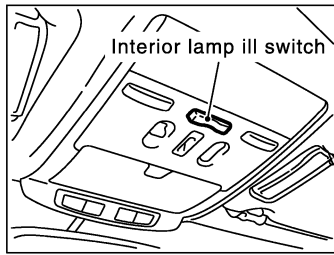

PIIA2871E

Diagnosis Result Display

- The indicator lamps (the map lamp and step lamp) turn ON (illuminate) for 2 seconds and OFF (go off) for 2 seconds to indicate that the diagnosis has started, then indicate the diagnosis trouble code.
- To indicate the diagnosis trouble code, the indicator lamps illuminate or flash.
- At first, the lamps indicate the second place by ON/OFF with 0.5 second-interval, then OFF for 1.5 seconds. Next, they indicate the first place by ON/OFF with 0.5 second interval.
- If there are multiple malfunctioning parts, the lamps indicate them in sequence from the smallest diagnosis trouble code.
- The diagnosis results repeat until the diagnosis is cancelled.
- If a malfunction is indicated, carry out the communication diagnosis again to check that the same diagnosis trouble code is indicated.

Diagnosis Trouble Code Indication Example

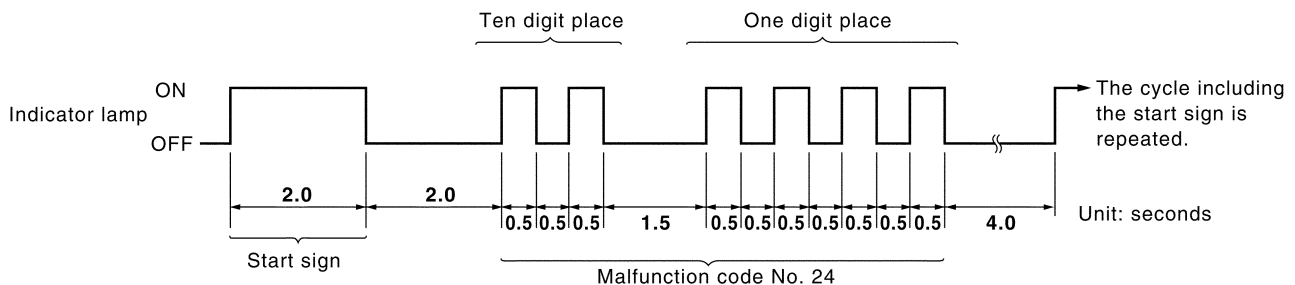

SIIA0410E

AUTOMATIC DRIVE POSITIONER

Trouble Diagnosis Chart

Malfunctioning item	Display unit	CONSULT-II IVMS communication diagnosis content	Self-diagnosis trouble code No.	Malfunctioning system and reference
COMM DATA	One LCU is displayed.	POWER WINDOW C/U-DR "COMMDATA"	24	Replace the displayed LCU.
		DOOR MIRROR C/U-RH "COMMDATA"	27	
		DOOR MIRROR C/U-LH "COMMDATA"	37	
		POWER SEAT C/U-DR "COMMDATA"	47	
	Multiple LCUs are displayed	BCM "COMMFAL1", "COMMFAL2"	Displays in order of 24 →27→37→47→ and cycles from 24.	Communication system A: Refer to SE-48 .
NO RESPONSE	One LCU is displayed.	POWER WINDOW C/U-DR "NORESPONSE"	25	Communication system B: Refer to SE-49 .
		DOOR MIRROR C/U-RH "NORESPONSE"	28	
		DOOR MIRROR C/U-LH "NORESPONSE"	38	
		POWER SEAT C/U-DR "NORESPONSE"	48	
	Multiple LCUs are displayed	BCM/HARNESS	Displays in order of 25→28→38→48 and cycles from 25.	Communication system C: Refer to SE-49 .
SLEEP malfunction	One LCU is displayed.	POWER WINDOW C/U-DR "SLEEP"	No self-diagnosis function	Replace the displayed LCU.
		DOOR MIRROR C/U-RH "SLEEP"		
		DOOR MIRROR C/U-LH "SLEEP"		
		POWER SEAT C/U-DR "SLEEP"		
	Multiple LCUs are displayed	All the above control units are displayed.	No self-diagnosis function	Communication system A: Refer to SE-48 .

NOTE:

- For a specific local control unit (LCU), either "PAST COMM DATA" or "PAST NO RESPONSE" may be displayed instead of the above results. This is caused by the data record, so erase the records.
(The display only shows the incident records, they are not malfunctions caused during the diagnosis. One possible cause is that an irreproducible incident occurred.)
- Follow the steps below to erase the memory.
Carry out either disconnect BCM battery power supply or erase memory with CONSULT-II.
- With the battery connected, if the local control unit (LCU) connector is disconnected and left for approximately 1 minute, the BCM stores "NO RESPONSE" record.

Cancel Of Communication Diagnosis

If one of the following conditions is satisfied, the communication diagnosis is cancelled.

- When the ignition switch is turned OFF.
- The vehicle speed becomes 7 km/h (4 MPH) or higher.
- Ten minutes have passed since the diagnostic result indication start without no diagnosis cancel operation.

COMMUNICATION SYSTEM A

1. CHECK BCM

Replace the BCM with a known-good one, and carry out the communication diagnosis. Refer to [SE-47, "COMMUNICATION DIAGNOSIS"](#) .

OK or NG

- OK >> Replace BCM
- NG >> GO TO 2.

AUTOMATIC DRIVE POSITIONER

2. CHECK LCU

1. Replace with the previously installed BCM.
2. Replace the LCU with a known-good one, and carry out the communication diagnosis. Refer to [SE-47, "COMMUNICATION DIAGNOSIS"](#).

OK or NG

- OK >> Replace LCU
- NG >> Repair the harness between the LCU and BCM.

COMMUNICATION SYSTEM B

1. CHECK HARNESS CONNECTOR

Check terminals (at the control unit and harness) on the malfunctioning LCU for disconnection, bend, poor connection and other malfunctions.

OK or NG

- OK >> GO TO 2.
- NG >> Repair the terminals and connectors.

2. CHECK LCU

Replace the malfunctioning LCU with a known-good one, and carry out the communication diagnosis. Refer to [SE-47, "COMMUNICATION DIAGNOSIS"](#).

OK or NG

- OK >> Replace LCU
- NG >> Repair the harness between the indicated LCU and BCM.

COMMUNICATION SYSTEM C

1. CHECK HARNESS CONNECTOR

Check terminals (at the control unit and harness) on BCM and LCU for disconnection, bend, poor connection, and other malfunctions.

OK or NG

- OK >> GO TO 2.
- NG >> Repair the terminals and connectors.

2. CHECK BCM

Replace the malfunctioning BCM with a known-good one, and carry out the communication diagnosis. Refer to [SE-47, "COMMUNICATION DIAGNOSIS"](#).

OK or NG

- OK >> Replace BCM
- NG >> Repair the harness between the LCU and BCM control.

A
B
C
D
E
F
G
H
SE
J
K
L
M

AUTOMATIC DRIVE POSITIONER

SWITCH MONITOR

Perform the diagnosis for the switch system input to each control unit.

Operation Procedure

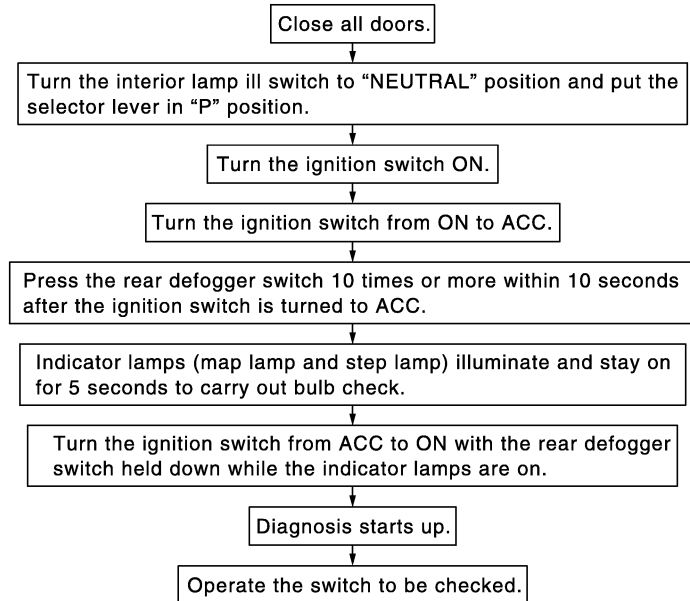
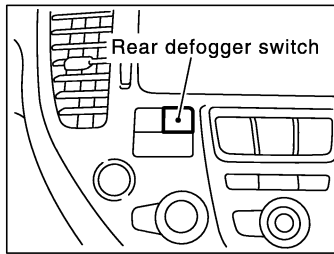
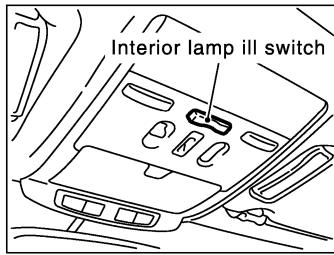

PIIA2869E

Diagnosis Result Display

- Detects the status change (switch ON/OFF operation) of the switch to be checked, and turns on/off the indicator lamps (the map lamp and step lamp). Also sounds the buzzer (the key remainder and light remainder) for 0.5 seconds.
- If a malfunction is detected, no indicator lamp and buzzer react.

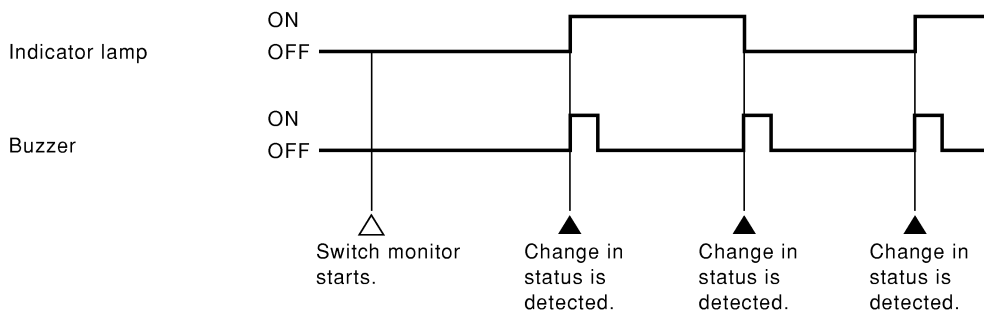

PIIA0185E

Diagnosis Item

The status of the switch (except the ignition switch, interior lamp switch, and map lamp switch) input to each control unit can be monitored.

Control unit	Item
BCM	Detention switch
	Steering wheel position switch (telescopic switch and tilt switch)
	Seat memory switch (memory switch 1, memory switch 2, and setting switch)
	Driver door switch
	Door mirror remote control switch
Driver seat control unit	Slide switch (FR/RR)
	Reclining switch (FR/RR)
	Front end lifting switch (UP/DOWN)
	Rear end lifting switch (UP/DOWN)

AUTOMATIC DRIVE POSITIONER

Cancel Of Switch Monitor

If one of the following conditions is satisfied, the switch monitor is cancelled.

- When the ignition switch is turned OFF.
- The vehicle speed becomes 7 km/h (4 MPH) or higher.

ON BOARD DIAGNOSIS FOR AUTOMATIC DRIVE POSITIONER

Check the operations of the auto drive positioner system.

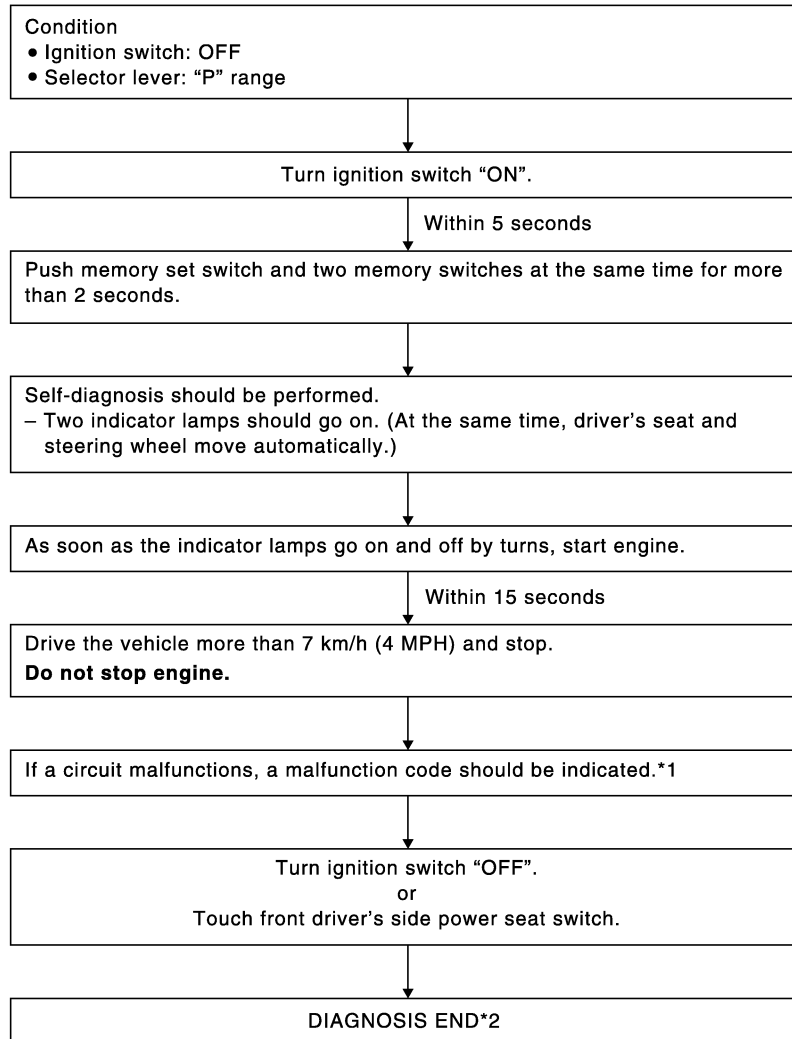

PIIA4472E

*1: If no malfunction is indicated, On board diagnosis for automatic drive positioner will end after the vehicle speed sensor diagnosis is performed.

*2: Diagnosis ends after self-diagnostic results have been indicated for 10 minutes if left unattended.

AUTOMATIC DRIVE POSITIONER

Diagnostic Result Display

- The malfunctioning items are indicated by how many times LEDs on the seat memory switches 1 and 2 flash simultaneously.

Code No.	Detected items	Indication of seat memory switches 1 and 2	Explanation
1	Seat sliding	IND1, IND2	
2	Seat reclining	IND1, IND2	While the seat motors are moving for 2.5 seconds, if the number of seat sliding/reclining/lifting sensor pulses changes 2 times or less, the seat device is determined to be malfunctioning.
3	Seat lifting front	IND1, IND2	
4	Seat lifting rear	IND1, IND2	
5	Steering telescopic	IND1, IND2	While the steering motors are moving, if the steering sensor output changes 0.2 volts or less, the steering device is determined to be malfunctioning.
6	Steering tilt	IND1, IND2	
7	Door mirrors (upper and lower)	IND1, IND2	When output voltage of either LH or RH door mirror sensor continues at less than 0.2V or more than 4.5V for 0.5 seconds or more, the door mirror is determined to be malfunctioning.
8	Door mirrors (LH and RH)	IND1, IND2	When output voltage of either LH or RH door mirror sensor continues at less than 0.2V or more than 4.5V for 0.5 seconds or more, the door mirror is determined to be malfunctioning.
9	Vehicle speed sensor circuit	IND1, IND2	If the vehicle speed sensor output of less than 7 km/h (4 MPH) is detected, the vehicle speed sensor is determined to be malfunctioning.
-	No malfunction in the above items		—

PIIA0190E

- If the vehicle speed is less than 7 km/h (4 MPH) for 15 seconds after the diagnosis for the seat and steering wheel systems were completed, the vehicle speed signal is judged malfunctioning.
- If LH door mirror is malfunctioning, only indicator lamp on the memory switch 1 flashes, and if RH door mirror is malfunctioning, only indicator lamp on the memory switch 2 flashes.
- When all the diagnosis are finished normally, the indicator lamps on the memory switches 1 and 2 go off after the vehicle speed signal diagnosis.
- If there are multiple malfunctioning parts, the lamps indicate them in sequence from the smallest diagnosis trouble code.
- The diagnosis results repeat until the diagnosis mode is cancelled.

AUTOMATIC DRIVE POSITIONER

Symptom Chart

E/S00BK9

Symptom	Diagnoses / service procedure	Refer to page
A part of seat system does not operate (both automatically and manually).	1. Sliding motor circuit inspection	SE-55
	2. Reclining motor circuit inspection	SE-56
	3. Front lifting motor circuit inspection	SE-66
	4. Rear lifting motor circuit inspection	SE-59
	5. If the above systems are normal, replace the BCM	—
A part of steering wheel system does not operate (both automatically and manually).	1. Telescopic motor circuit inspection	SE-60
	2. Tilt motor circuit inspection	SE-62
	3. If the above systems are normal, replace the BCM	—
Door mirrors cannot be actuated in both automatic and manual modes.	1. Door mirror remote control switch (changeover switch) circuit inspection	GW-108
	2. Door mirror remote control switch (mirror switch) system inspection	GW-111
	3. If the above systems are normal, replace the BCM.	—
A part of seat system does not operate (only automatic operation).	1. Sliding sensor circuit inspection	SE-64
	2. Reclining sensor circuit inspection	SE-65
	3. Front lifting sensor circuit inspection	SE-66
	4. Rear lifting sensor circuit inspection	SE-67
	5. If the above systems are normal, replace the driver seat control unit	—
Door mirrors cannot be actuated in automatic mode.	1. Back-up input signal circuit inspection in R position	GW-110
	2. Mirror sensors circuit inspection	GW-114
	3. If the above systems are normal, replace the door mirror control unit.	—
All the automatic operations do not operate.	1. Detention switch circuit inspection	SE-68
	2. Telescopic sensor circuit inspection	SE-69
	3. Tilt sensor circuit inspection	SE-70
	4. Vehicle speed signal inspection	SE-75
	5. If all the above systems are normal, replace the BCM	—
Seat or steering wheel memory does not work.	1. Seat memory switch circuit inspection	SE-76
	2. If the above systems are normal, replace the BCM.	—
Only manual operation does not operate.	1. Sliding switch circuit inspection	SE-78
	2. Reclining switch circuit inspection	SE-80
	3. Front lifting switch circuit inspection	SE-82
	4. Rear lifting switch circuit inspection	SE-84
	5. Telescopic switch circuit inspection	SE-86
	6. Tilt system switch circuit inspection	SE-88
	7. Door mirror remote control switch (mirror switch) circuit inspection	GW-111
	8. If all the above systems are normal, replace the driver seat control unit for the seat system, the BCM for the steering wheel system	—
The entry / exiting does not operated when door is opened and closed (The entry / exiting operates with key switch)	1. Seat memory indicator lamp circuit inspection	SE-90
	2. If the above systems are normal, replace the BCM.	—

AUTOMATIC DRIVE POSITIONER

Symptom	Diagnoses / service procedure	Refer to page
Seat memory indicator lamps 1 and 2 do not illuminate.	1. Front door switch (driver side) circuit inspection	SE-73
	2. If the above systems are normal, replace the BCM.	-
Auto driving position system self-diagnosis does not work.(With out CONSULT-II)	1. Detention switch circuit inspection	SE-68
	2. Key switch and key lock solenoid circuit inspection	SE-71
	3. Seat memory switch circuit inspection	SE-76
	4. Seat memory indicator lamp circuit inspection	SE-90
	5. Vehicle speed signal inspection	SE-75
	6. If all the above systems are normal, retry the self-diagnosis. If the self-diagnosis are still disable, check the driver seat control unit connector and terminals for looseness and damage.	-
Lumber support motor does not operated.	1. Lumber support circuit inspection	SE-91
Turnout operation of rear power seat LH does not operate, bat rear power seat can be operated by rear power seat switch.	1. Rear power seat turnout operation inspection.	SE-93

AUTOMATIC DRIVE POSITIONER

EIS008KA

Sliding Motor Circuit Inspection

1. CHECK SEAT SLIDING MECHANISM

Check the following.

- Operation malfunction caused by sliding rail deformation or pinched harness or other foreign materials
- Operation malfunction caused by foreign materials adhered to the sliding motor or sliding rail connector rod
- Operation malfunction and interference with other parts by poor installation

OK or NG

OK >> GO TO 2.

NG >> Repair the malfunction part and check again.

2. CHECK FUNCTION

 With CONSULT-II

Check operation with "SEAT SLIDE" in ACTIVE TEST.

Test item	Description
SEAT SLIDE	The sliding motor is activated by receiving the drive signal.

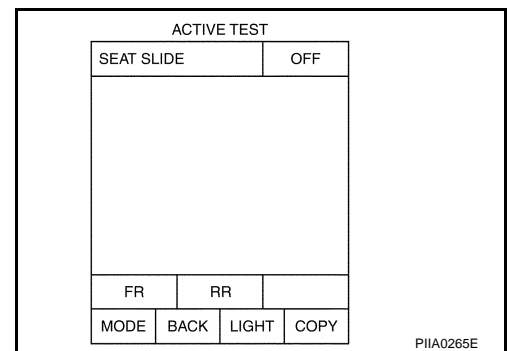

 Without CONSULT-II

Perform the on-board diagnosis. Refer to [SE-51, "ON BOARD DIAGNOSIS FOR AUTOMATIC DRIVE POSITIONER"](#).

OK or NG

OK >> System is OK.

NG >> GO TO 3.

3. CHECK HARNESS CONTINUITY

1. Turn ignition switch OFF.
2. Disconnect driver seat control unit connector and sliding motor connector.
3. Check continuity between driver seat control unit connector B142 terminals 1 (W), 8 (BR) and sliding motor connector B146 terminals 1 (W), 8 (BR).

1 (W) – 1 (W) : Continuity should exist.

8 (BR) – 8 (BR) : Continuity should exist.

4. Check continuity between driver seat control unit connector B142 terminals 1 (W), 8 (BR) and ground.

1 (W) – Ground :Continuity should not exist.

8 (BR) – Ground :Continuity should not exist.

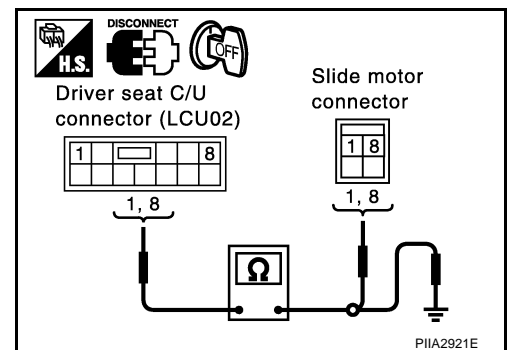

OK or NG

OK >> GO TO 4.

NG >> Repair or replace harness between driver seat control unit and sliding motor.

AUTOMATIC DRIVE POSITIONER

4. CHECK DRIVER SEAT CONTROL UNIT OUTPUT SIGNAL

1. Connect the driver seat control unit connector and sliding motor connector.
2. Check voltage between the driver seat control unit connector.

Connector	Terminals (Wire color)		Condition	Voltage (V) (Approx.)
	(+)	(-)		
B142	1 (W)	Ground	Sliding switch (forward operation).	Battery voltage
			Sliding switch OFF.	0
	8 (BR)		Sliding switch (backward operation).	Battery voltage
			Sliding switch OFF.	0

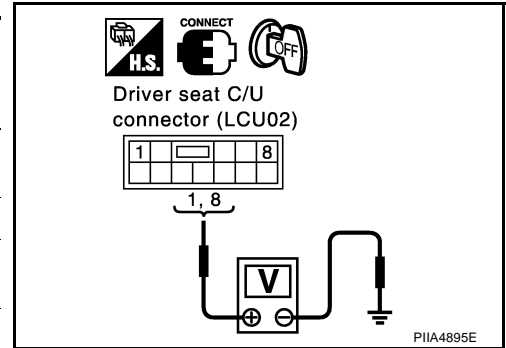

OK or NG

- OK >> Replace sliding motor.
- NG >> Replace driver seat control unit.

Reclining Motor Circuit Inspection

EIS008KB

1. CHECK SEAT RECLINING MECHANISM

Check following.

- Operation malfunction caused by an interference with the center pillar or center console
- Operation malfunction and interference with other parts by poor installation

OK or NG

- OK >> GO TO 2.
- NG >> Repair the malfunction part and check again.

2. CHECK FUNCTIONAL

With CONSULT-II

Check operation with "SEAT RECLINING" in ACTIVE TEST.

Test item	Description
SEAT RECLINING	The reclining motor is activated by receiving the drive signal.

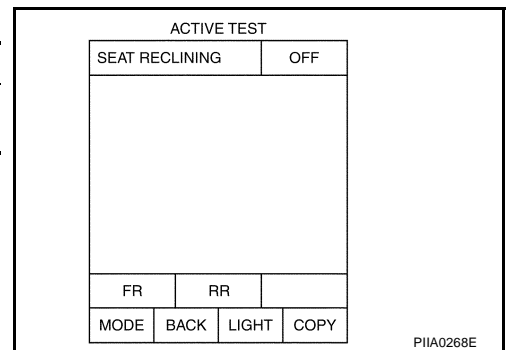

Without CONSULT-II

Perform the self-diagnosis. Refer to [SE-51, "ON BOARD DIAGNOSIS FOR AUTOMATIC DRIVE POSITIONER"](#).

OK or NG

- OK >> System is OK.
- NG >> GO TO 3.

AUTOMATIC DRIVE POSITIONER

3. CHECK HARNESS CONTINUITY

1. Turn ignition switch OFF.
2. Disconnect driver seat control unit congregator and reclining motor connector.
3. Check continuity between driver seat control unit connector B142 terminals 2 (G), 9 (LG) and reclining motor connector B147 terminals 2 (G), 9 (LG).

2 (G) – 2 (G) : Continuity should exist.

9 (LG) – 9 (LG) : Continuity should exist.

4. Check continuity between driver seat control unit connector B142 terminals 2 (G), 9 (LG) and ground.

2 (G) – Ground :Continuity should not exist.

9 (LG) – Ground :Continuity should not exist.

OK or NG

OK >> GO TO 4.

NG >> Repair or replace harness between driver seat control unit and reclining motor.

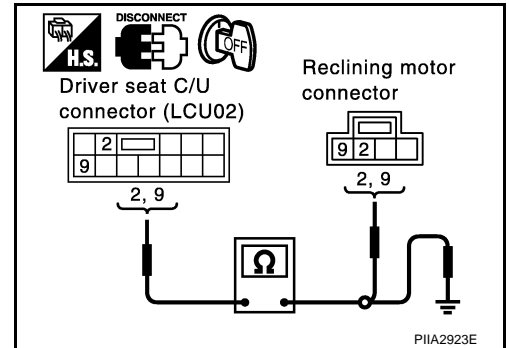

4. CHECK DRIVER SEAT CONTROL UNIT OUTPUT SIGNAL

1. Connect the driver seat control unit and reclining motor connector.
2. Check voltage between driver seat control unit connector.

Connector	Terminals (Wire color)		Condition	Voltage (V) (Approx.)
	(+)	(-)		
B142	2 (G)	Ground	Reclining switch (forward operation).	Battery voltage
			Reclining switch OFF.	0
	9 (LG)		Reclining switch (backward operation).	Battery voltage
			Reclining switch OFF.	0

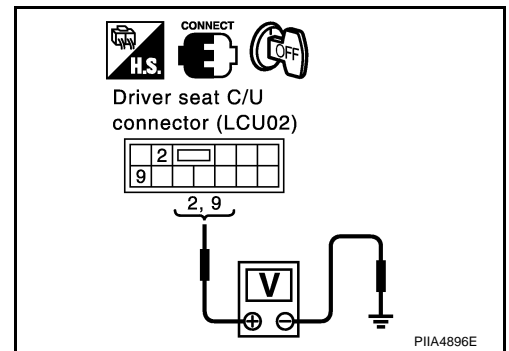

OK or NG

OK >> Replace reclining motor.

NG >> Replace driver seat control unit.

Front Lifting Motor Circuit Inspection

EIS008KC

1. CHECK FRONT LIFTING MECHANISM

Check the following.

- Operation malfunction caused by lifter mechanism deformation or pinched harness or other foreign materials
- Operation malfunction caused by foreign materials adhered to the lifter motor or lead screws
- Operation malfunction and interference with other parts by installation

OK or NG

OK >> GO TO 2.

NG >> Repair the malfunctioning part and check again.

AUTOMATIC DRIVE POSITIONER

2. CHECK FUNCTION

With CONSULT-II

Check operation with "SEAT LIFTER FR" in ACTIVE TEST.

Test item	Description
SEAT LIFTER FR	The front end lifter motor is activated by receiving the drive signal.

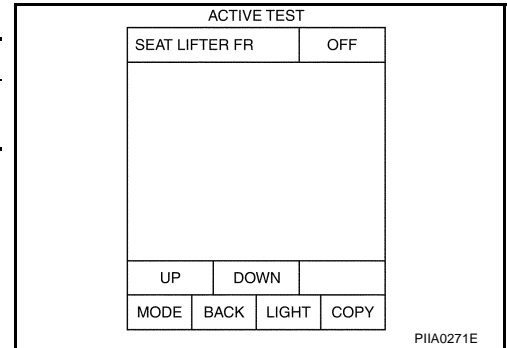

Without CONSULT-II

Perform the on-board diagnosis. Refer to [SE-51, "ON BOARD DIAGNOSIS FOR AUTOMATIC DRIVE POSITIONER"](#).

OK or NG

- OK >> System is OK.
- NG >> GO TO 3.

3. CHECK HARNESS CONTINUITY

1. Turn ignition switch OFF.
2. Disconnect driver seat control unit connector and front lifting motor connector.
3. Check continuity between driver seat control unit connector B142 and terminals 10 (OR), 11 (P) and front lifting motor connector B148 terminals 10 (OR), 11 (P).

10 (OR) – 10 (OR) : Continuity should exist.

11 (P) – 11 (P) : Continuity should exist.

4. Check continuity between driver seat control unit connector B142 and terminals 10 (OR), 11 (P) and ground.

10 (OR) – Ground :Continuity should not exist.

11 (P) – Ground :Continuity should not exist.

OK or NG

- OK >> GO TO 4.
- NG >> Repair or replace harness between driver seat control unit and front lifting motor.

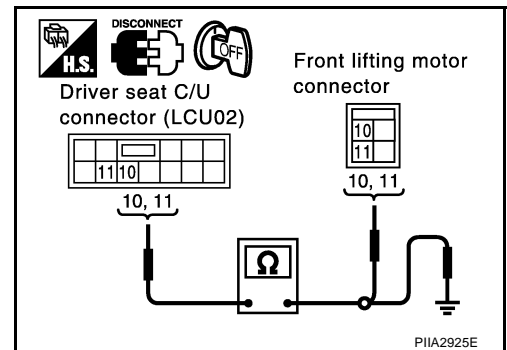

AUTOMATIC DRIVE POSITIONER

4. CHECK DRIVER SEAT CONTROL UNIT OUTPUT SIGNAL

1. Connect the driver seat control unit connector and front lifting motor connector.
2. Check voltage between driver seat control unit connector.

Connector	Terminals (Wire color)		Condition	Voltage (V) (Approx.)
	(+)	(-)		
B142	10 (OR)	Ground	Front end lifting switch (DOWN operation).	Battery voltage
			Front end lifting switch OFF.	0
	11 (P)		Front end lifting switch (UP operation).	Battery voltage
			Front end lifting switch OFF.	0

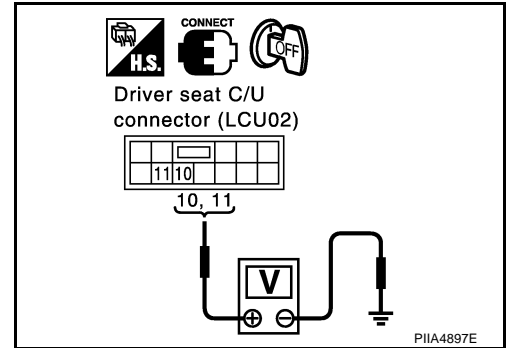

OK or NG

- OK >> Replace front lifting motor.
- NG >> Replace driver seat control unit.

Rear Lifting Motor Circuit Inspection

EIS008KD

1. CHECK REAR LIFTING MECHANISM

Check following items.

- Operation malfunction caused by lifter mechanism deformation or pinched harness or other foreign materials
- Operation malfunction caused by foreign materials adhered to the lifter motor or lead screws
- Operation malfunction and interference with other parts by poor installation

OK or NG

- OK >> GO TO 2.
- NG >> Repair the malfunctioning part and check again.

2. CHECK FUNCTION

With CONSULT-II

Check operation with "SEAT LIFTER RR" in ACTIVE TEST.

Test item	Description
SEAT LIFTER RR	The rear end lifter motor is activated by receiving the drive signal.

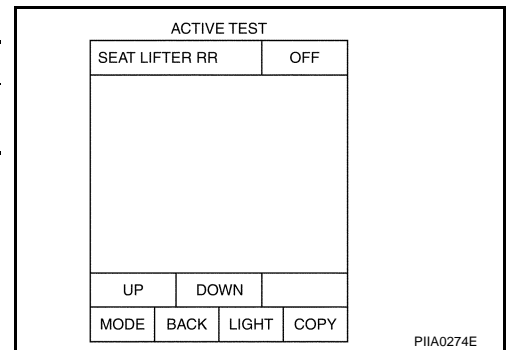

Without CONSULT-II

Perform the on-board diagnosis. Refer to [SE-51, "ON BOARD DIAGNOSIS FOR AUTOMATIC DRIVE POSITIONER"](#).

OK or NG

- OK >> System is OK.
- NG >> GO TO 3.

AUTOMATIC DRIVE POSITIONER

3. CHECK HARNESS CONTINUITY

1. Turn ignition switch OFF.
2. Disconnect driver seat control unit connector and rear lifting motor connector.
3. Check continuity between driver seat control unit connector B142 terminals 4 (Y), 6 (PU) and lifting motor connector B149 terminals 4 (Y), 6 (PU).

4 (Y) – 4 (Y) : Continuity should exist.

6 (PU) – 6 (PU) : Continuity should exist.

4. Check continuity between driver seat control unit B142 terminals 4 (Y), 6 (PU) and ground.

4 (Y) – Ground :Continuity should not exist.

6 (PU) – Ground :Continuity should not exist.

OK or NG

OK >> GO TO 4.

NG >> Repair or replace harness between driver seat control unit and rear lifting motor.

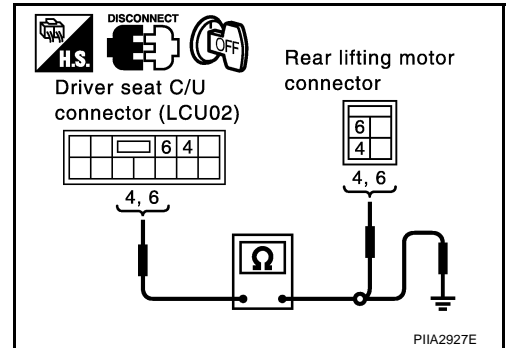

4. CHECK DRIVER SEAT CONTROL UNIT OUTPUT SIGNAL

1. Connect driver seat control unit and rear lifting motor.
2. Check voltage between driver seat control unit connector.

Connector	Terminals (Wire color)		Condition	Voltage (V) (Approx.)
	(+)	(-)		
B142	6 (PU)	Ground	Rear end lifting switch (UP operation)	Battery voltage
			Rear end lifting switch OFF	0
	4 (Y)		Rear end lifting switch (DOWN operation)	Battery voltage
			Rear end lifting switch OFF	0

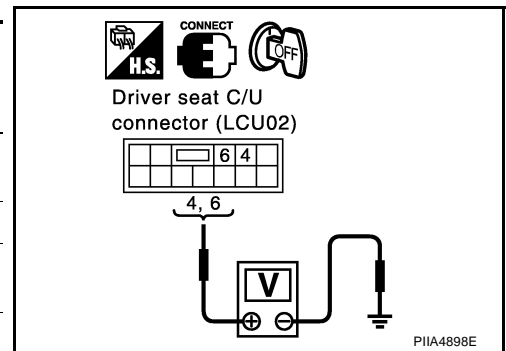

OK or NG

OK >> Replace rear lifting motor.

NG >> Replace driver seat control unit.

Telescopic Motor Circuit Inspection

EIS008KE

1. CHECK STEERING WHEEL TELESCOPIC MECHANISM

Check following.

- Operation malfunction caused by steering wheel telescopic mechanism deformation or pinched harness or other foreign materials
- Operation malfunction and interference with other parts by poor installation

OK or NG

OK >> GO TO 2.

NG >> Repair the malfunctioning part and check again.

AUTOMATIC DRIVE POSITIONER

2. CHECK FUNCTION

With CONSULT-II

Check operation with "TELESCO MOTOR" in ACTIVE TEST.

Test item	Description
TELESCO MOTOR	The telescopic motor is activated by receiving the drive signal.

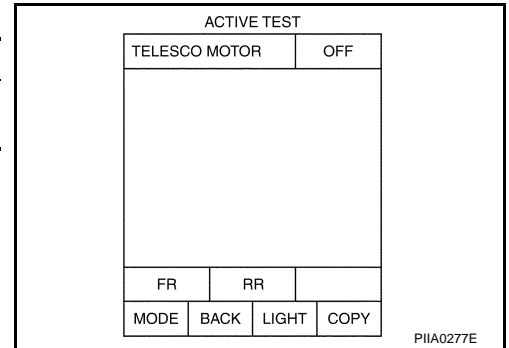

Without CONSULT-II

Perform the on-board diagnosis. Refer to [SE-51, "ON BOARD DIAGNOSIS FOR AUTOMATIC DRIVE POSITIONER"](#).

OK or NG

OK >> System is OK.

NG >> GO TO 3.

3. CHECK HARNESS CONTINUITY

- Turn ignition switch OFF.
- Disconnect BCM and telescopic motor connector.
- Check continuity between BCM connector M4 terminals 101 (R/W), 107 (R) and telescopic motor connector M60 terminals 1 (R/W), 2 (R).

101 (R/W) – 1 (R/W) : Continuity should exist.

107 (R) – 2 (R) : Continuity should exist.

- Check continuity between BCM connector M4 terminals 101 (R/W), 107 (R) and ground.

101 (R/W) – Ground :Continuity should not exist.

107 (R) – Ground :Continuity should not exist.

OK or NG

OK >> GO TO 4.

NG >> Repair or replace harness between BCM and telescopic motor.

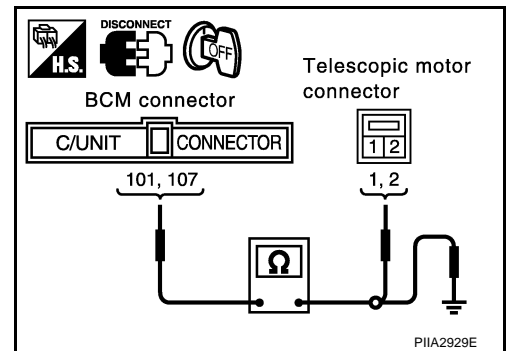

AUTOMATIC DRIVE POSITIONER

4. CHECK BCM OUTPUT SIGNAL

1. Connect the BCM connector and telescopic motor connector.
2. Check voltage between BCM connector.

Connector	Terminals (Wire color)		Condition	Voltage (V) (Approx.)
	(+)	(-)		
M4	101 (R/W)	Ground	Telescopic switch (forward operation).	Battery voltage
			Telescopic switch OFF.	0
	107 (R)		Telescopic switch (backward operation).	Battery voltage
			Telescopic switch OFF.	0

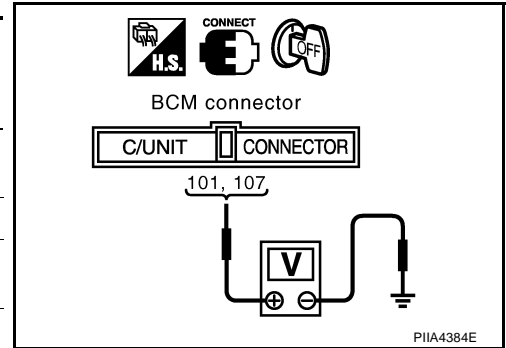

OK or NG

- OK >> Replace telescopic motor.
- NG >> Replace BCM.

Tilt Motor Circuit Inspection

EIS008KF

1. CHECK STEERING WHEEL TILT MECHANISM

Check following.

- Operation malfunction caused by steering wheel tilt mechanism deformation or pinched harness or other foreign materials
- Operation malfunction and interference with other parts by poor installation

OK or NG

- OK >> GO TO 2.
- NG >> Repair the malfunctioning part and check again.

2. CHECK FUNCTION

With CONSULT-II

Check operation with "TILT MOTOR" in ACTIVE TEST.

Test item	Description
TILT MOTOR	The tilt motor is activated by receiving the drive signal.

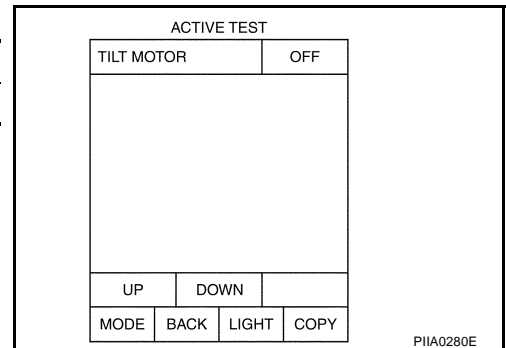

Without CONSULT-II

Perform the on-board diagnosis. Refer to [SE-51, "ON BOARD DIAGNOSIS FOR AUTOMATIC DRIVE POSITIONER"](#).

OK or NG

- OK >> System is OK.
- NG >> GO TO 3.

AUTOMATIC DRIVE POSITIONER

3. CHECK HARNESS CONTINUITY

1. Turn ignition switch OFF.
2. Disconnect BCM connector and tilt motor connector.
3. Check continuity between BCM connector M4 terminals 102 (P), 103 (R/B) and tilt motor connector M58 terminals 1 (R/B), 2 (P).

102 (P) – 2 (P) : Continuity should exist.

103 (R/B) – 1 (R/B) : Continuity should exist.

4. Check continuity between BCM connector M4 terminals 102 (P), 103 (R/B) and ground.

102 (P) – Ground :Continuity should not exist.

103 (R/B) – Ground :Continuity should not exist.

OK or NG

OK >> GO TO 4.

NG >> Repair or replace harness between BCM and tilt motor.

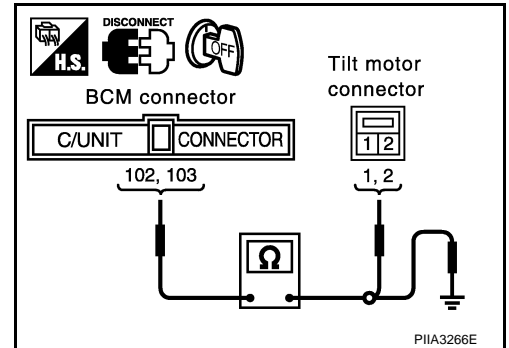

4. CHECK BCM OUTPUT SIGNAL

1. Connect BCM connector and tilt motor connector.
2. Check voltage between BCM connector.

Connector	Terminals (Wire color)		Condition	Voltage (V) (Approx.)
	(+)	(-)		
M4	102 (P)	Ground	Tilt switch (DOWN operation).	Battery voltage
			Tilt switch OFF.	0
	103 (R/B)		Tilt switch (UP operation).	Battery voltage
			Tilt switch OFF.	0

OK or NG

OK >> Replace tilt motor.

NG >> Replace BCM.

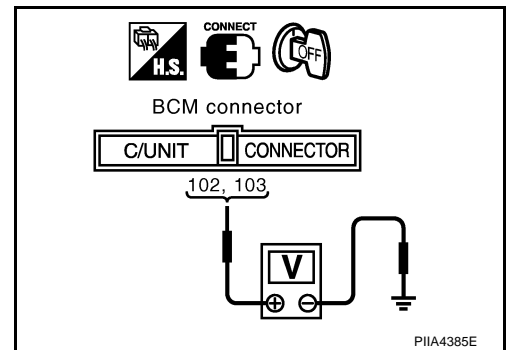

AUTOMATIC DRIVE POSITIONER

EIS008KG

Sliding Sensor Circuit Inspection

1. CHECK SLIDING SENSOR MECHANISM

Check the operation malfunction caused by sliding rail deformation or parts are loose.

OK or NG

- OK >> GO TO 2.
- NG >> Repair the malfunctioning part and check again.

2. CHECK SLIDING SENSOR INPUT/OUTPUT SIGNAL

1. Turn ignition switch OFF.
2. Check signal between driver seat control unit connector and ground, with oscilloscope.

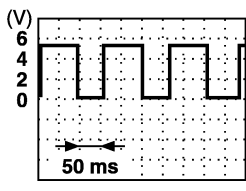
Connector	Terminals (Wire color)		Condition	Signal (Reference valve)
	(+)	(-)		
B143	20 (G/B)	Ground	Sliding motor operation	 <p style="text-align: right; font-size: small;">PIIA3277E</p>

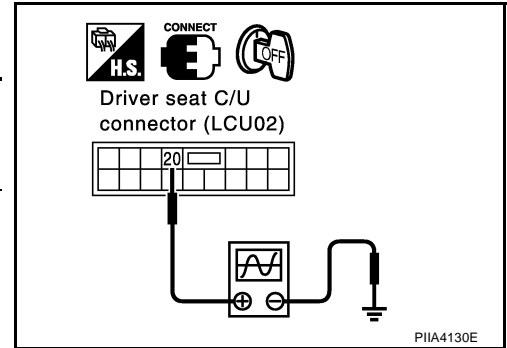

OK or NG

- OK >> System is OK.
- NG >> GO TO 3.

3. CHECK HARNESS CONTINUITY

1. Disconnect driver seat control unit connector and sliding motor connector.
2. Check continuity between driver seat control unit connector B143 terminals 20 (G/B), 32 (R/W) and sliding motor B146 terminals 20 (G/B), 32A (R/W).

- 20 (G/B) – 20 (G/B) : Continuity should exist.**
- 32 (R/W) – 32A (R/W) : Continuity should exist.**

3. Check continuity between driver seat control unit B143 terminals 20 (G/B), 32 (R/W) and ground.

- 20 (G/B) – Ground :Continuity should not exist.**
- 32 (R/W) – Ground :Continuity should not exist.**

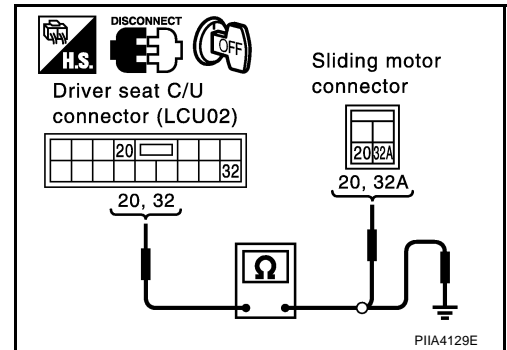

OK or NG

- OK >> Replace sliding motor.
- NG >> Repair or replace harness between driver seat control unit and sliding motor.

AUTOMATIC DRIVE POSITIONER

EIS008KH

Reclining Sensor Circuit Inspection

1. CHECK RECLINING SENSOR MECHANISM

Check the operation malfunction caused by reclining mechanism deformation or parts are loose.

OK or NG

OK >> GO TO 2.

NG >> Repair the malfunctioning part and check again.

2. CHECK RECLINING SENSOR INPUT/OUTPUT SIGNAL

1. Turn ignition switch OFF.
2. Check signal between driver seat control unit connector and ground, with oscilloscope.

Connector	Terminals (Wire color)		Condition	Signal (Reference value)
	(+)	(-)		
B143	30 (L)	Ground	Reclining motor operation	<p>PIIA3278E</p>

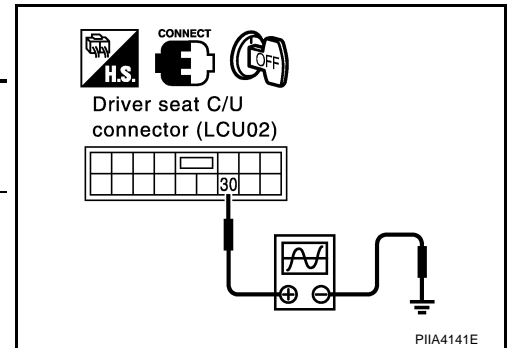

OK or NG

OK >> System is OK.

NG >> GO TO 3.

3. CHECK HARNESS CONTINUITY

1. Disconnect driver seat control unit connector and reclining motor connector.
2. Check continuity between driver seat control unit connector B143 terminals 30 (L), 32 (R/W) and reclining motor connector B147 terminals 30 (L), 32 (R/W).

30 (L) – 30 (L) : Continuity should exist.

32 (R/W) – 32 (R/W) : Continuity should exist.

3. Check continuity between driver seat control unit connector B143 terminals 30 (L), 32 (R/W) and ground.

30 (L) – Ground :Continuity should not exist.

32 (R/W) – Ground :Continuity should not exist.

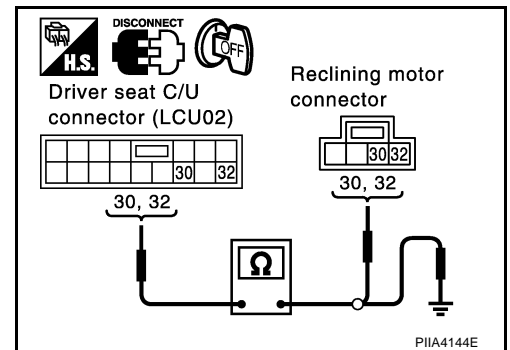

OK or NG

OK >> Replace reclining motor.

NG >> Repair or replace harness between driver seat control unit and reclining motor.

AUTOMATIC DRIVE POSITIONER

EIS008K1

Front Lifting sensor Circuit Inspection

1. CHECK FRONT LIFTING SENSOR MECHANISM

Check the operation malfunction caused by lifter mechanism deformation or parts are loose.

OK or NG

OK >> GO TO 2.

NG >> Repair the malfunctioning part and check again.

2. CHECK FRONT LIFTING SENSOR INPUT/OUTPUT SIGNAL

1. Turn ignition switch OFF.
2. Check signal between driver seat control unit connector and ground, with oscilloscope.

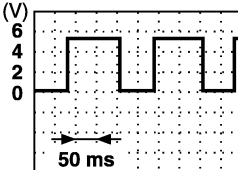
Connector	Terminals (Wire color)		Condition	Signal (Reference value)
	(+)	(-)		
B143	21 (Y/B)	Ground	Front lifting motor operation	 <p>PIIA3278E</p>

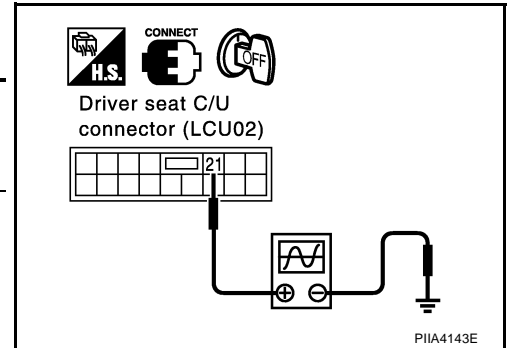

OK or NG

OK >> System is OK.

NG >> GO TO 3.

3. CHECK HARNESS CONTINUITY

1. Disconnect driver seat control unit connector and front lifting motor connector.
2. Check continuity between driver seat control unit connector B143 terminals 21 (Y/B), 32 (R/W) and front lifting motor connector B148 terminals 21 (Y/B), 32B (R/W).

21 (Y/B) – 21 (Y/B) : Continuity should exist.

32 (R/W) – 32B (R/W) : Continuity should exist.

3. Check continuity between driver seat control unit connector B143 terminals 21 (Y/B), 32 (R/W) and ground.

21 (Y/B) – Ground :Continuity should not exist.

32 (R/W) – Ground :Continuity should not exist.

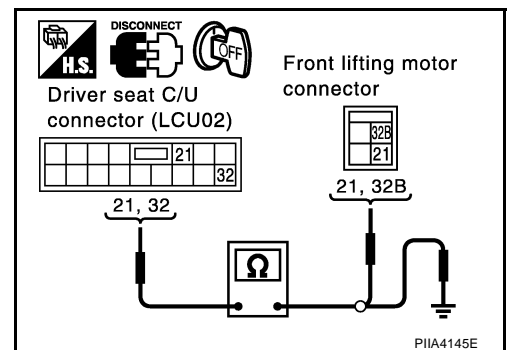

OK or NG

OK >> Replace front lifting motor.

NG >> Repair or replace harness between driver seat control unit and front lifting motor.

AUTOMATIC DRIVE POSITIONER

EIS008KJ

Rear Lifting Sensor Circuit Inspection

1. CHECK REAR LIFTING SENSOR INPUT/OUTPUT SIGNAL

1. Turn ignition switch OFF.
2. Check signal between driver seat control unit connector ground with oscilloscope.

Connector	Terminals (Wire color)		Condition	Signal (Reference value)
	(+)	(-)		
B143	31 (W/R)	Ground	Rear lifting motor operation	<p style="text-align: right;">S1IA0693J</p>

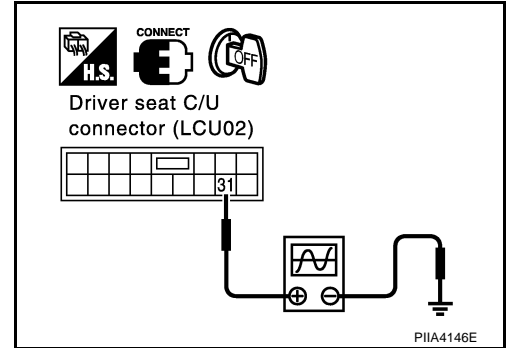

OK or NG

- OK >> System is OK.
NG >> GO TO 2.

2. CHECK REAR LIFTING SENSOR MECHANISM

Check the operation malfunction caused by lifter mechanism deformation or parts are loose.

OK or NG

- OK >> GO TO 3.
NG >> Repair the malfunctioning part and check again.

3. CHECK HARNESS CONTINUITY

1. Disconnect driver seat control unit connector and rear lifting motor connector.
2. Check continuity between driver seat control unit connector B143 terminals 31 (W/R), 32 (R/W) and rear lifting motor connector B149 terminals 31 (W/R), 32C (R/W).

31 (W/R) – 31 (W/R) : Continuity should exist.

32 (R/W) – 32C (R/W) : Continuity should exist.

3. Check continuity between driver seat control unit connector B143 terminals 31 (W/R), 32 (R/W) and ground.

31 (W/R) – Ground :Continuity should not exist.

32 (R/W) – Ground :Continuity should not exist.

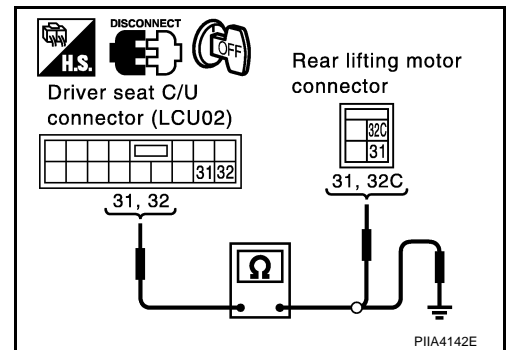

OK or NG

- OK >> Replace rear lifting motor.
NG >> Repair or replace harness between driver seat control unit and rear lifting motor.

AUTOMATIC DRIVE POSITIONER

EIS008KK

Detention Switch Circuit Inspection

1. CHECK FUNCTION

With CONSULT-II

Check that when the A/T selector lever is in P-position, "DETENT SW" on the DATA MONITOR becomes ON.

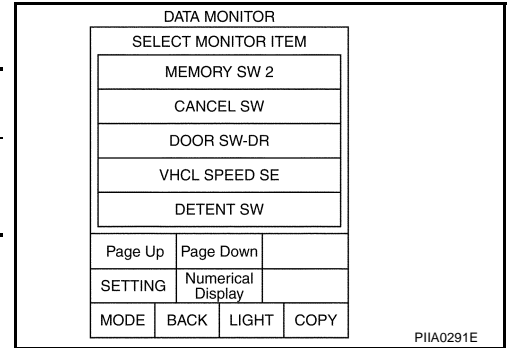

Monitor item [OPERATION or UNIT]	Contents
DETENT SW	"ON/OFF" The selector lever position "P position (ON)/other than P position (OFF)" judged from the detente switch signal is displayed.

Without CONSULT-II

Carry out "SWITCH MONITOR" in the self-diagnosis function, and operate the A/T selector lever to check. Refer to [SE-50. "SWITCH MONITOR"](#).

OK or NG

- OK >> System is OK.
- NG >> GO TO 2.

2. CHECK DETENTION SWITCH POWER SUPPLY CIRCUIT HARNESS

1. Turn ignition switch OFF.
2. Disconnect A/T device (detention switch) connector and key switch and key lock solenoid connector.
3. Check continuity harness between A/T device (detention switch) connector M97 terminal 6 (PU/W) and key switch and key lock solenoid connector M64 terminal 4 (PU/W).

6 (PU/W) – 4 (PU/W) : Continuity should exist.

4. Check continuity harness between A/T device (detention switch) connector M97 terminal 6 (PU/W) and ground.

6 (PU/W) – Ground :Continuity should not exist.

OK or NG

- OK >> GO TO 3.
- NG >> Repair or replace harness between A/T device (detention switch) and key switch and key lock solenoid.

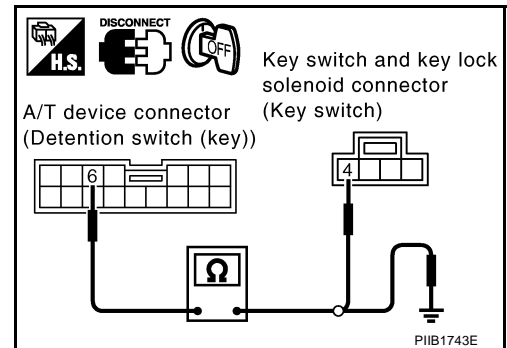

3. CHECK DETENTION SWITCH

Check continuity between A/T device (detention switch) connector M97 terminal 6 and 7.

Connector	Terminals	Condition	Continuity
M97	6	7	P-position No
			Other than P-position Yes

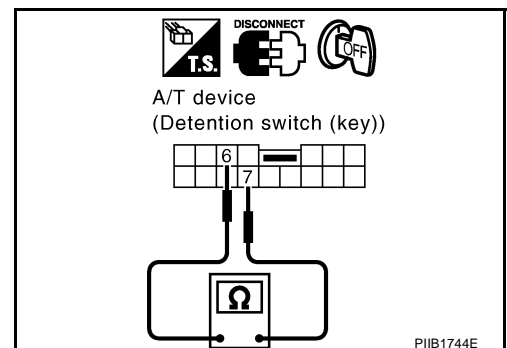

OK or NG

- OK >> GO TO 4.
- NG >> Replace detention switch.

AUTOMATIC DRIVE POSITIONER

4. CHECK DETENTION SWITCH SIGNAL HARNESS

1. Disconnect BCM connector.
2. Check continuity between BCM connector M4 terminal 8 (G/OR) and A/T device (detention switch) connector M97 terminal 7 (G/OR).

8 (G/OR) – 7(G/OR) : Continuity should exist.

3. Check continuity harness between BCM connector M4 terminal 8 (G/OR) and ground.

8 (G/OR) – Ground : Continuity should not exist.

OK or NG

- OK >> Replace BCM.
- NG >> Repair or replace harness between BCM and A/T device (detention switch).

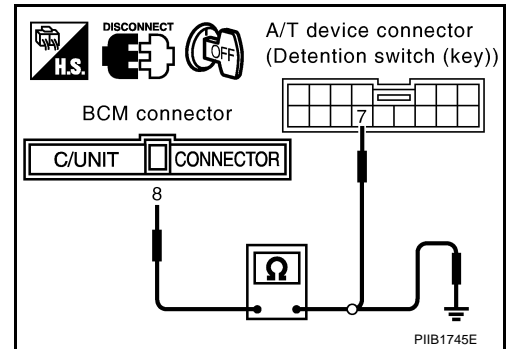

EIS008KL

Telescopic Sensor Circuit Inspection

1. CHECK STEERING WHEEL TILT MECHANISM

Check the operation malfunction caused by steering wheel tilt mechanism deformation or parts are loose.

OK or NG

- OK >> GO TO 2.
- NG >> Repair the malfunctioning part and check again.

2. CHECK FUNCTION

With CONSULT-II

Operate the telescopic switch with "TELESCO SEN" on the DATA MONITOR to check that the voltage changes.

Monitor item [OPERATION or UNIT]	Contents
TELESCO SEN	"V" The telescoping position (voltage) judged from the telescoping sensor signal is displayed.

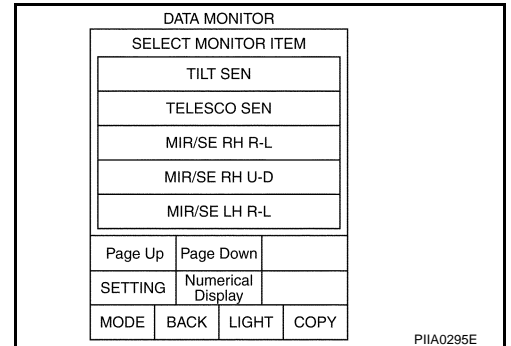

Without CONSULT-II

1. Turn ignition switch OFF.
2. Check voltage between BCM connector and ground.

Connector	Terminals (Wire color)		Condition	Voltage (V) (Approx.)
	(+)	(-)		
M4	62 (P/B)	Ground	Telescopic top position	2
			Telescopic bottom position	4

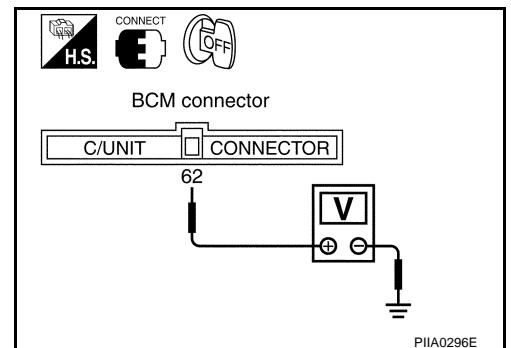

OK or NG

- OK >> System is OK.
- NG >> GO TO 3.

AUTOMATIC DRIVE POSITIONER

3. CHECK HARNESS CONTINUITY

1. Disconnect BCM connector and telescopic sensor connector.
2. Check continuity harness between BCM connector M4 terminals 53 (L/W), 54 (LG/B), 62 (P/B) and telescopic sensor connector M59 terminals 1 (LG/B), 2 (P/B), 3 (L/W).

53 (L/W) – 3 (L/W) : Continuity should exist.
54(LG/B) – 1 (LG/B) : Continuity should exist.
62 (P/B) – 2 (P/B) : Continuity should exist.

3. Check continuity harness between BCM connector M4 terminals 53 (L/W), 54 (LG/B), 62 (P/B) and ground.

53 (L/W) – Ground : Continuity should not exist.
54 (LG/B) – Ground : Continuity should not exist.
62 (P/B) – Ground : Continuity should not exist.

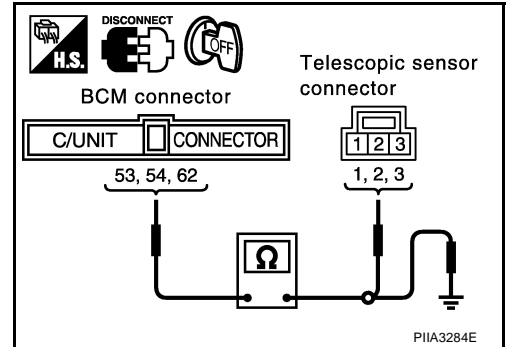

OK or NG

- OK >> Replace telescopic sensor.
 NG >> Repair or replace harness between BCM and telescopic sensor.

Tilt Sensor Circuit Inspection

EIS008KM

1. CHECK TILT STEERING MECHANISM

Check the operation malfunction caused by steering wheel tilt mechanism deformation or parts are loose.

OK or NG

- OK >> GO TO 2.
 NG >> Repair the malfunctioning part and check again.

2. CHECK FUNCTION

With CONSULT-II

With "TILT SEN" on the DATA MONITOR, operate the tilt switch to check that the voltage changes.

Monitor item [OPERATION or UNIT]	Contents
TILT SEN	"V" The tilt position (voltage) judged from the tilt sensor signal is displayed.

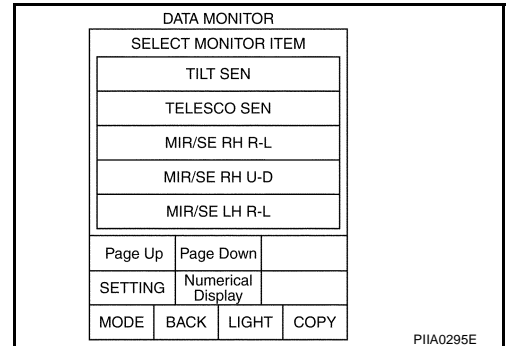

Without CONSULT-II

1. Turn ignition switch OFF.
2. Check voltage between BCM connector and ground.

Connector	Terminals (Wire color)		Condition	Voltage (V) (Approx.)
	(+)	(-)		
M4	46 (P/L)	Ground	Tilt top position	2
			Tilt bottom position	4

OK or NG

- OK >> System is OK.
 NG >> GO TO 3.

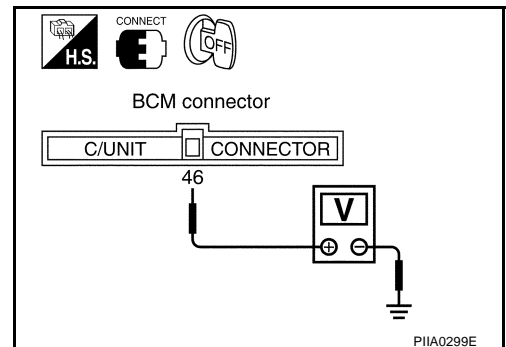

AUTOMATIC DRIVE POSITIONER

3. CHECK HARNESS

1. Disconnect BCM connector and tilt sensor connector.
2. Check continuity harness between BCM connector M4 terminals 46 (P/L), 53 (L/W), 54 (LG/B) and tilt sensor connector M57 terminals 1 (LG/B), 2 (P/L), 3 (L/W).

- 46 (P/L) – 2 (P/L) : Continuity should exist.
 53 (L/W) – 3 (L/W) : Continuity should exist.
 54 (LG/B) – 1 (LG/B) : Continuity should exist.

3. BCM connector M4 terminals 46 (P/L), 53 (L/W), 54 (LG/B) and ground.

- 46 (P/L) – Ground : Continuity should not exist.
 53 (L/W) – Ground : Continuity should not exist.
 54 (LG/B) – Ground : Continuity should not exist.

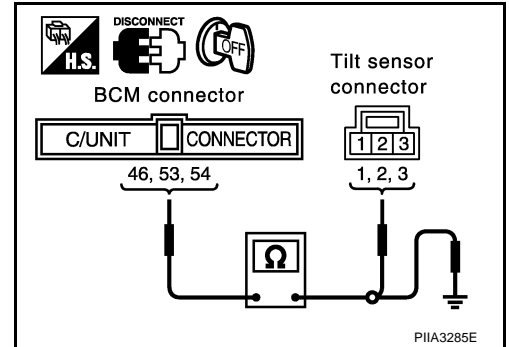

OK or NG

- OK >> Replace tilt sensor.
 NG >> Repair or replace harness between BCM and tilt sensor.

Key Switch and Key Lock Solenoid Circuit Inspection.

EIS008KN

1. CHECK KEY SWITCH AND KEY LOCK SOLENOID

With CONSULT-II

With "IGN KEY SW" on the DATA MONITOR, Check ON/OFF operation.

Monitor item [OPERATION or UNIT]	Contents	
IGN KEY SW	"ON/OFF"	Key inserted (ON)/key removed (OFF) status judged from the key detection switch is displayed.

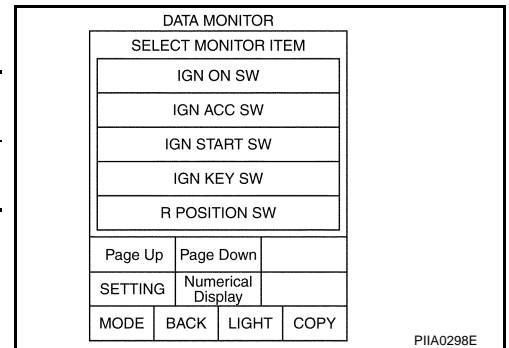

Without CONSULT-II

Check voltage between BCM connector ground.

Connector	Terminals (Wire color)		Condition	Voltage (V) (Approx.)
	(+)	(-)		
M4	69 (PU/W)	ground	Remove the key	0
			Insert the key	Battery voltage

OK or NG

- OK >> System is OK.
 NG >> GO TO 2.

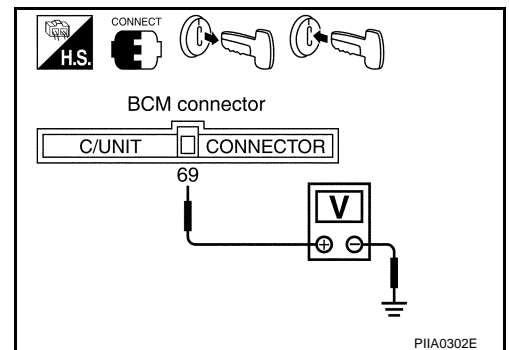

AUTOMATIC DRIVE POSITIONER

2. CHECK FUSE

Check if any of the following fuses is blown.

Power source	Fuse No.	Unit
BAT power supply	32 (10A)	Fuse block (J/B) No. 2

NOTE:

Refer to [SE-17, "Component Parts and Harness Connector Location"](#) .

OK or NG

OK >> GO TO 3.

NG >> If fuse is blown, be sure to eliminate cause of problem before installing new fuse. Refer to [PG-2, "POWER SUPPLY ROUTING"](#) .

3. KEY SWITCH AND KEY LOCK SOLENOID POWER SUPPLY CIRCUIT INSPECTION

1. Turn ignition switch OFF,
2. Check voltage between key switch and key lock solenoid connector M64 terminal 3 (W) and ground.

3 (LG) – Ground : Battery voltage.

OK or NG

OK >> GO TO 4.

NG >> Check harness between key switch and key lock solenoid and fuse.

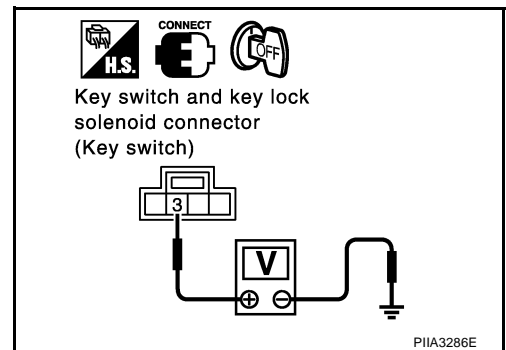

4. CHECK KEY SWITCH

1. Disconnect key switch connector.
2. Check continuity between key switch connector M64 terminal 3 and 4.

Connector	Terminals		Condition	Continuity
	3	4		
M64	3	4	Key is inserted in ignition key cylinder.	Yes
			Key is removed from ignition key cylinder.	No

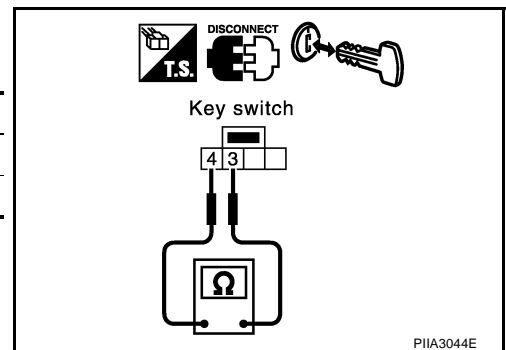

OK or NG

OK >> GO TO 5.

NG >> Replace key switch and key lock solenoid (key switch) switch.

AUTOMATIC DRIVE POSITIONER

5. CHECK HARNESS CONTINUITY

1. Disconnect key switch and key lock solenoid connector and BCM connector.
2. Check continuity between key switch and key lock solenoid connector M64 terminal 4 (PU/W) and BCM connector M4 terminal 69 (PU/W).

4 (PU/W) – 69 (PU/W) : Continuity should exist.

3. Check continuity between key switch and key lock solenoid connector M64 terminal 4 (PU/W) and ground.

4 (PU/W) – Ground : Continuity should not exist.

OK or NG

- OK >> Check the condition of the harness and connector.
 NG >> Repair or replace harness between key switch and key lock solenoid and BCM.

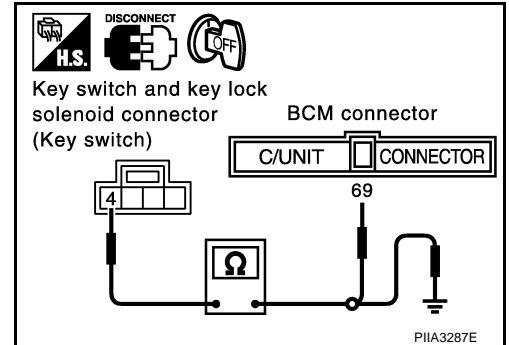

Front Door Switch (Driver Side) Circuit Inspection.

1. CHECK FUNCTION

Ⓜ With CONSULT-II

With "DOOR SW DR" on the DATA MONITOR, check ON/OFF operation when the driver door is open and closed.

Monitor item [OPERATION or UNIT]		Contents
DOOR SW DR	"ON/OFF"	Door open (ON)/door closed (OFF) status judged from the driver door switch is displayed.

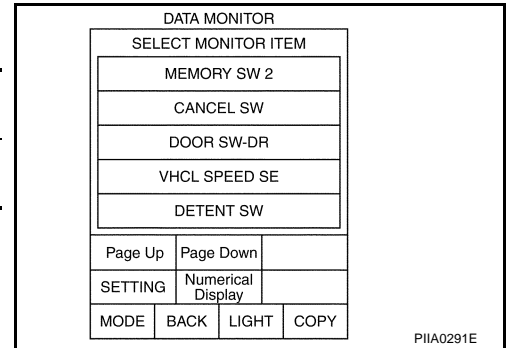

⊗ Without CONSULT-II

Carry out "SWITCH MONITOR" in the self-diagnosis function, and open and close the driver door to check. Refer to [SE-50, "SWITCH MONITOR"](#).

OK or NG

- OK >> System is OK.
 NG >> GO TO 2.

2. CHECK FRONT DOOR SWITCH (DRIVER SIDE)

1. Turn ignition switch OFF.
2. Disconnect door switch (driver side) connector.
3. Check continuity between (driver side) door switch connector B20 terminal 1 and ground part of door switch.

Connector	Terminals		Condition	Continuity
B20	1	Ground part of door switch	With the front door switch (driver side) pressed.	No
			With the front door switch (driver side) released.	Yes

OK or NG

- OK >> GO TO 3.
 NG >> Replace door switch (driver side).

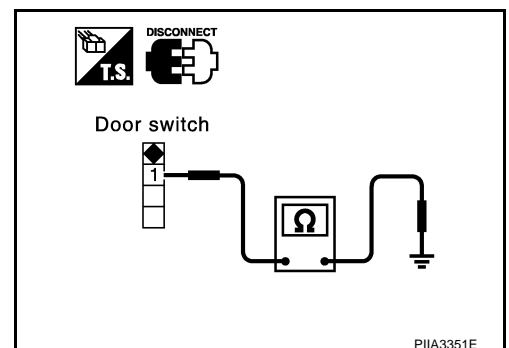

AUTOMATIC DRIVE POSITIONER

3. CHECK HARNESS CONTINUITY

1. Disconnect BCM connector.
2. Check continuity between BCM connector M4 terminal 142 (W/R) and front door switch connector B20 terminal 1 (W/R).

142 (W/R) – 1 (W/R) : Continuity should exist.

3. Check continuity between BCM connector M4 terminal 142 (W/R) and ground.

142 (W/R) – Ground : Continuity should not exist.

OK or NG

OK >> Replace BCM.

NG >> Repair or replace harness between BCM and front door switch (driver side).

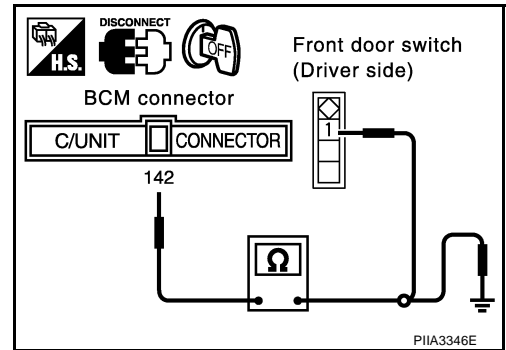

AUTOMATIC DRIVE POSITIONER

EIS008KP

Vehicle Speed Signal Inspection

1. CHECK SYMPTOM

Check that the speedometer in the combination meter operates normally.

OK or NG

OK >> GO TO 2.

NG >> Check vehicle speed signal. Refer to [DI-7, "COMBINATION METERS"](#).

2. CHECK FUNCTION

With CONSULT-II

With "VHCL SPEED SE" on the DATA MONITOR, Check vehicle speed signal.

Monitor item [OPERATION or UNIT]		Contents
VHCL SPEED SE	"7km/7km"	The present vehicle speed (less than 7 km/h (4 MPH), or 7 km/h (4 MPH) or higher) is displayed.

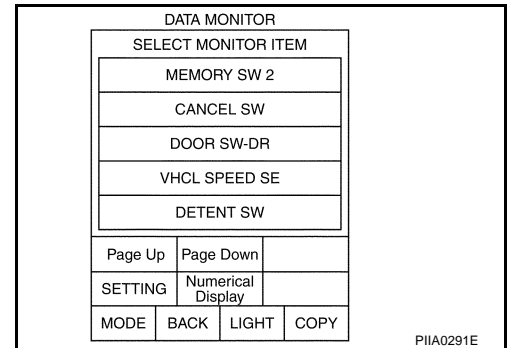

Without CONSULT-II

Perform the on-board diagnosis. Refer to [SE-51, "ON BOARD DIAGNOSIS FOR AUTOMATIC DRIVE POSITIONER"](#).

OK or NG

OK >> System is OK.

NG >> GO TO 3.

3. CHECK VEHICLE SPEED INPUT/OUTPUT

1. Start the engine.
2. Check signal between BCM connector and ground, with oscilloscope.

Connector	Terminals (Wire color)		Condition	Signal (Reference value)
	(+)	(-)		
M4	49 (PU/W)	Ground	Vehicle speed is approx.40 km/h (25 MPH)	

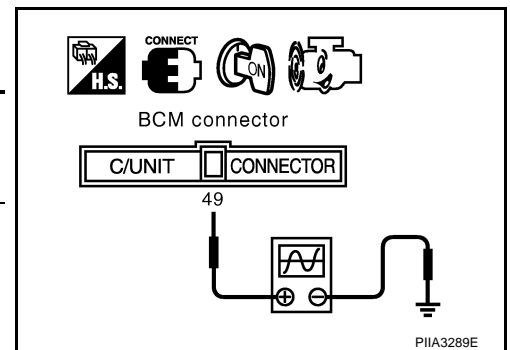

OK or NG

OK >> Replace BCM.

NG >> GO TO 4.

AUTOMATIC DRIVE POSITIONER

4. CHECK HARNESS CONTINUITY

1. Turn ignition switch OFF.
2. Disconnect BCM and combination meter connector.
3. Check continuity between BCM connector M4 terminal 49 (PU/W) and combination meter connector M41 terminal 18 (PU/W).
49 (PU/W) – 18 (PU/W) : Continuity should exist.
4. Check continuity between BCM connector M4 terminal 49 (PU/W) and ground.
49 (PU/W) – Ground : Continuity should not exist.

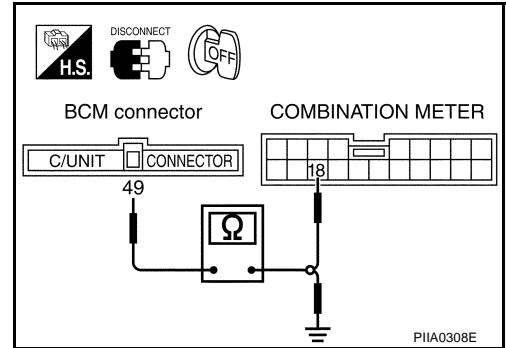

OK or NG

- OK >> Check meter control unit [DI-16, "HOW TO PROCEED WITH TROUBLE DIAGNOSIS"](#)
- NG >> Repair or replace harness between BCM and combination meter.

Seat Memory Switch Circuit Inspection

EIS008KQ

1. CHECK FUNCTION

Ⓟ With CONSULT-II

With "SET SW, MEMORY SW1 MEMORY SW2" on the DATA MONITOR, operate the switch to check ON/OFF operation.

Monitor item [OPERATION or UNIT]	Contents
MEMORY SW1	"ON/OFF" ON / OFF status judged from the seat memory switch 1 signal is displayed.
MEMORY SW2	"ON/OFF" ON/OFF status judged from the seat memory switch 2 signal is displayed.
SET SW	"ON/OFF" ON/OFF status judged from the setting switch signal is displayed.

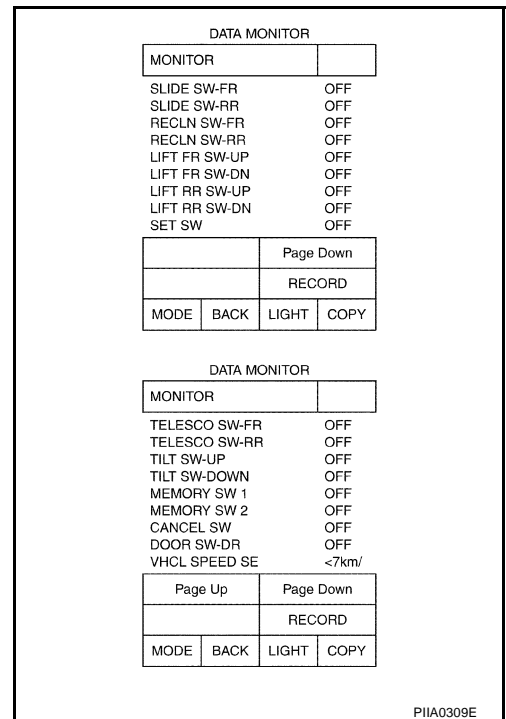

ⓧ Without CONSULT-II

Carry out "switch monitor" in the on-board diagnosis function, and operate "Setting switch, memory switch 1, memory switch 2" to check. Refer to [SE-50, "SWITCH MONITOR"](#).

OK or NG

- OK >> System is OK.
- NG >> GO TO 2.

AUTOMATIC DRIVE POSITIONER

2. CHECK SEAT MEMORY SWITCH

1. Turn ignition switch OFF.
2. Disconnect seat memory switch connector.
3. Check continuity between seat memory switch connector and ground.

Connector	Terminals	Condition	Continuity
D3	3	Set switch: ON	Yes
		Set switch: OFF	No
	1	Memory switch 1 ON	Yes
		Memory switch 1: OFF	No
		Memory switch 2: ON	Yes
		Memory switch 2: OFF	No

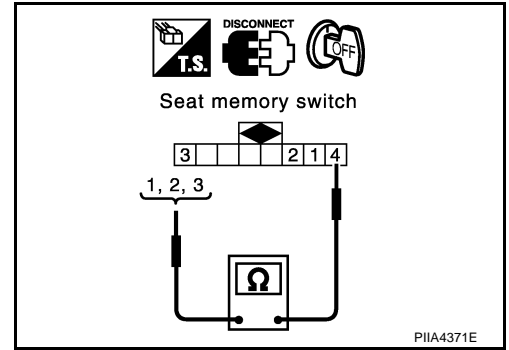

OK or NG

- OK >> GO TO 3.
 NG >> Replace seat memory switch.

3. CHECK HARNESS CONTINUITY

1. Disconnect BCM connector.
2. Check continuity between BCM connector M4 terminals 39 (G), 43 (OR), 50 (R/Y) and seat memory switch connector D3 terminals 1 (G), 2 (OR), 3 (R/Y).

- 39 (G) – 1 (G) : Continuity should exist.**
43 (OR) – 2 (OR) : Continuity should exist.
50 (R/Y) – 3 (R/Y) : Continuity should exist.

3. Check continuity between BCM connector M4 terminals 39 (G), 43 (OR), 50 (R/Y) and ground.

- 39 (G) – Ground : Continuity should not exist.**
43 (OR) – Ground : Continuity should not exist.
50 (R/Y) – Ground : Continuity should not exist.

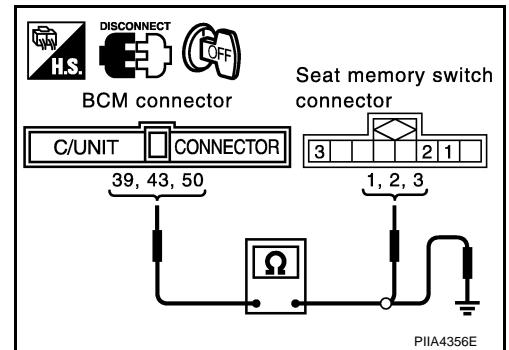

OK or NG

- OK >> GO TO 4.
 NG >> Repair or replace harness between BCM and seat memory switch.

4. CHECK SEAT MEMORY SWITCH GROUND CIRCUIT

Check continuity at harness between seat memory switch D3 terminal 4 (B) and ground.

- 4 (B) – Ground : Continuity should exist.**

OK or NG

- OK >> Replace BCM.
 NG >> Repair or replace harness between seat memory switch and ground.

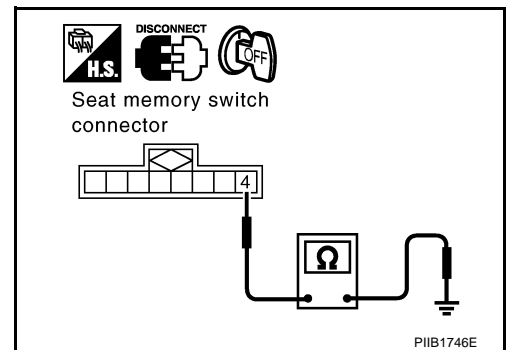

AUTOMATIC DRIVE POSITIONER

EIS008KR

Sliding Switch Circuit Inspection

1. CHECK FUNCTION

With CONSULT-II

With "SLIDE SW-FR,SLIDE SWRR" on the DATA MONITOR, operate the sliding switch to check ON/OFF operation.

Monitor item [OPERATION or UNIT]		Contents
SLIDE SW-FR	"ON/OFF"	ON /OFF status judged from the sliding switch (FR) signal is displayed.
SLIDE SW-RR	"ON/OFF"	ON / OFF status judged from the sliding switch (RR) signal is displayed.

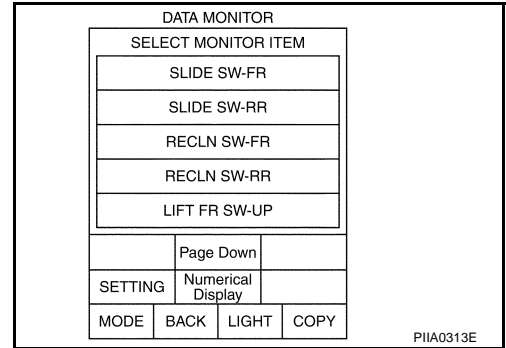

Without CONSULT-II

Carry out "SWITCH MONITOR" in the on-barad diagnosis function, and operate the sliding switch to check. Refer to [SE-50. "SWITCH MONITOR"](#).

OK or NG

- OK >> Replace the driver seat control unit.
- NG >> GO TO 2.

2. CHECK SLIDING SWITCH INPUT/OUTPUT

1. Turn ignition switch OFF.
2. Check voltage between driver seat control unit connector and ground.

Connector	Terminals (Wire color)		Condition	Voltage (V) (Approx.)
	(+)	(-)		
B143	17 (Y/R)	Ground	Sliding switch ON (forward operation).	0
			Sliding switch OFF.	5
	23 (G/W)		Sliding switch ON (backward operation).	0
			Sliding switch OFF.	5

OK or NG

- OK >> System is OK.
- NG >> GO TO 3.

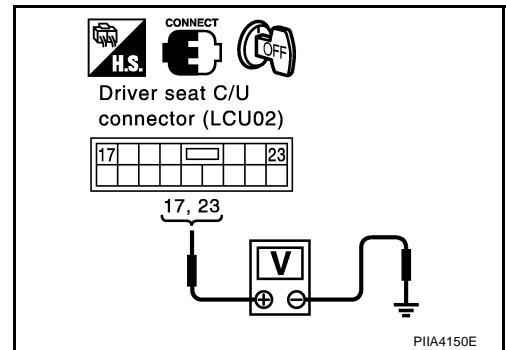

AUTOMATIC DRIVE POSITIONER

3. CHECK HARNESS CONTINUITY

1. Disconnect driver seat control unit connector and power seat switch (driver side) connector.
2. Check continuity between driver seat control unit connector B143 terminals 17 (Y/R), 23 (G/W) and driver power seat switch connector B144 terminals 17 (Y/R), 23 (G/W).

17 (Y/R) – 17 (Y/R) : Continuity should exist.
23 (G/W) – 23 (G/W) : Continuity should exist.

3. Check continuity between driver seat control unit connector B143 terminals 17(Y/R), 23 (G/W) and ground.

17 (Y/R) – Ground : Continuity should not exist.
23 (G/W) – Ground : Continuity should not exist.

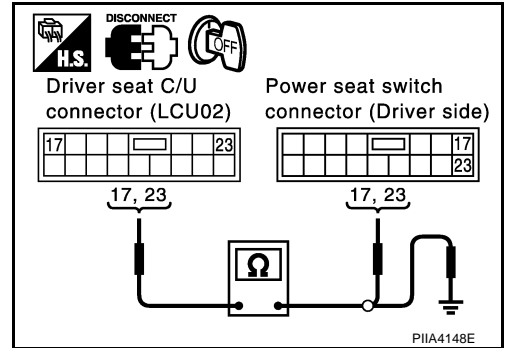

OK or NG

- OK >> GO TO 4.
 NG >> Repair or replace harness between driver seat control unit and power seat switch.

4. CHECK SLIDING SWITCH

Check continuity between driver seat control unit connector B144 terminal 17, 23 and 15.

Connector	Terminals		Condition	Continuity
B144	17	15	Sliding switch ON (forward operation).	Yes
			Sliding switch OFF.	No
	23		Sliding switch ON (backward operation).	Yes
			Sliding switch OFF.	No

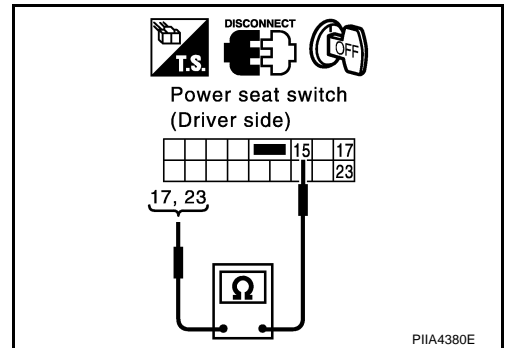

OK or NG

- OK >> GO TO 5.
 NG >> Replace driver power seat switch.

5. CHECK POWER SEAT SWITCH GROUND CIRCUIT

Check continuity between power seat switch (driver side) connector B144 terminal 15 (B) and ground.

15 (B) – Ground : Continuity should exist.

OK or NG

- OK >> Check the condition of the harness and connector.
 NG >> Repair or replace harness between driver seat switch and ground.

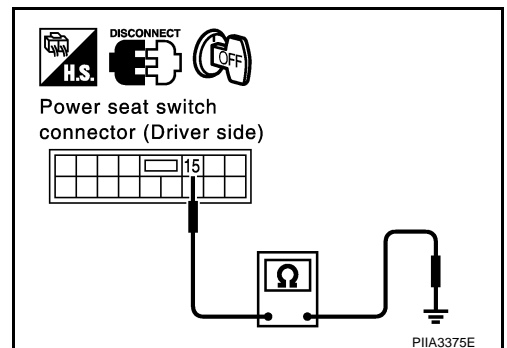

AUTOMATIC DRIVE POSITIONER

EIS008KS

Reclining Switch System Inspection

1. CHECK FUNCTION

With CONSULT-II

With "RECLINING SW-FR,RECLINING SWRR" on the DATA MONITOR, operate the reclining switch to check ON/OFF operation.

Monitor item [OPERATION or UNIT]		Contents
RECLN SW-FR	"ON/OFF"	Operation (ON)/open (OFF) status judged from the reclining switch (FR) signal is displayed.
RECLIN SW-RR	"ON/OFF"	Operation (ON)/open (OFF) status judged from the reclining switch (RR) signal is displayed.

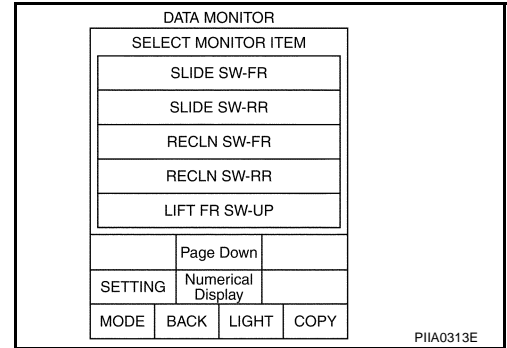

Without CONSULT-II

Carry out "SWITCH MONITOR" in the on-board diagnosis function, and operate the reclining switch to check. Refer to [SE-50. "SWITCH MONITOR"](#).

OK or NG

- OK >> Replace the driver seat control unit.
- NG >> GO TO 2.

2. CHECK RECLINING SWITCH INPUT/OUTPUT

1. Turn ignition switch OFF.
2. Check voltage between driver seat control unit connector and ground.

Connector	Terminals (Wire color)		Condition	Voltage (V) (Approx.)
	(+)	(-)		
B143	18 (GY/B)	Ground	Reclining switch ON (forward operation).	0
			Reclining switch OFF.	5
	24 (SB)		Reclining switch ON (backward operation).	0
			Reclining switch OFF.	5

OK or NG

- OK >> System is OK.
- NG >> GO TO 3.

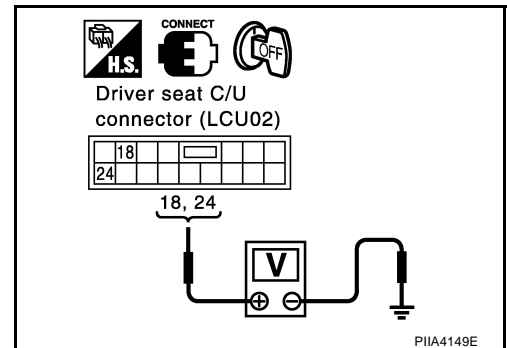

AUTOMATIC DRIVE POSITIONER

3. CHECK HARNESS CONTINUITY

1. Disconnect driver seat control unit connector and power seat switch (driver side) connector.
2. Check continuity between driver seat control unit connector B143 terminals 18 (GY/B), 24 (SB) and power seat switch (driver side) connector B144 terminals 18 (GY/B), 24 (SB).

18 (GY/B) – 18 (GY/B) :Continuity should exist.

24 (SB) – 24 (SB) :Continuity should exist.

3. Check continuity between driver seat control unit connector B143 terminals 18 (GY/B), 24 (SB) and ground.

18 (GY/B) – Ground :Continuity should not exist.

24 (SB) – Ground :Continuity should not exist.

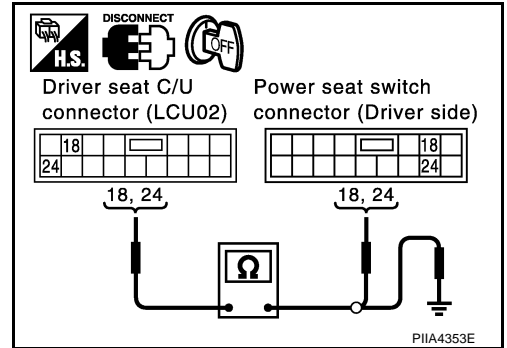

OK or NG

OK >> GO TO 4.

NG >> Repair or replace harness between driver seat control unit and power seat switch.

4. CHECK RECLINING SWITCH

Check continuity between driver seat control unit connector B144 terminal 18, 24 and 15.

Connector	Terminals	Condition	Continuity
B144	18	Reclining switch ON (forward operation).	Yes
		Reclining switch OFF.	No
	24	Reclining switch ON (backward operation).	Yes
		Reclining switch OFF.	No

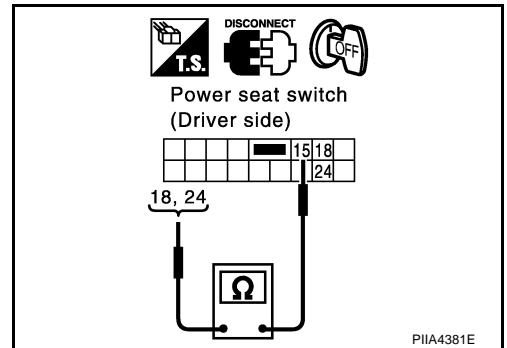

OK or NG

OK >> GO TO 5.

NG >> Replace power seat switch (driver side).

5. CHECK POWER SEAT SWITCH GROUND CIRCUIT

Check continuity between power seat switch B144 terminal 15 (B) and ground.

15 (B) – Ground: : Continuity should exist.

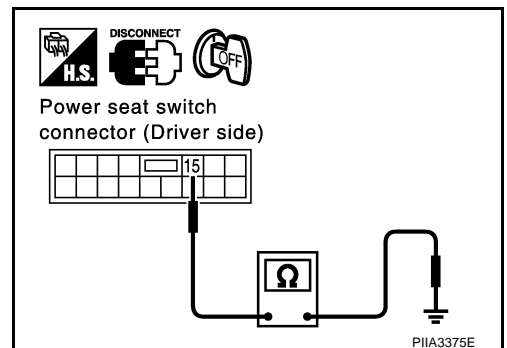

OK or NG

OK >> Check the condition of the harness and connector.

NG >> Repair or replace harness between power seat switch (driver side) and ground.

AUTOMATIC DRIVE POSITIONER

EIS008KT

Front Lifting Switch Circuit Inspection

1. CHECK FUNCTION

With CONSULT-II

With "LIFT FR SW-UP, LIFT FR SW-DN" on the DATA MONITOR, operate the front lifting switch to check ON/OFF operation.

Monitor item [OPERATION or UNIT]		Contents
LIFT FR SW-DN	"ON/OFF"	Operation (ON)/open (OFF) status judged from the FR lifter switch (DOWN) signal is displayed.
LIFT RR SW-UP	"ON/OFF"	Operation (ON)/open (OFF) status judged from the RR lifter switch (UP) signal is displayed.

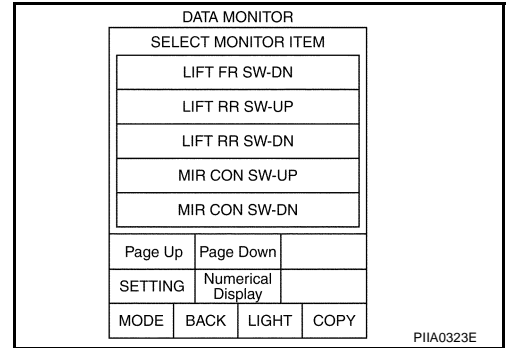

Without CONSULT-II

Carry out "SWITCH MONITOR" in the on-board diagnosis function, and operate the front lifting switch to check. Refer to [SE-50, "SWITCH MONITOR"](#).

OK or NG

- OK >> Replace the driver seat control unit.
- NG >> GO TO 2

2. CHECK FRONT LIFTING SWITCH INPUT/OUTPUT

1. Turn ignition switch OFF.
2. Check voltage between driver seat control unit B143 and ground.

Connector	Terminals (Wire color)		Condition	Voltage (V) (Approx.)
	(+)	(-)		
B143	19 (L/R)	Ground	Front lifting switch ON (UP operation).	0
			Front lifting switch OFF.	5
	25 (OR/B)		Front lifting switch ON. (DOWN operation)	0
			Front lifting switch OFF.	5

OK or NG

- OK >> System is OK.
- NG >> GO TO 3.

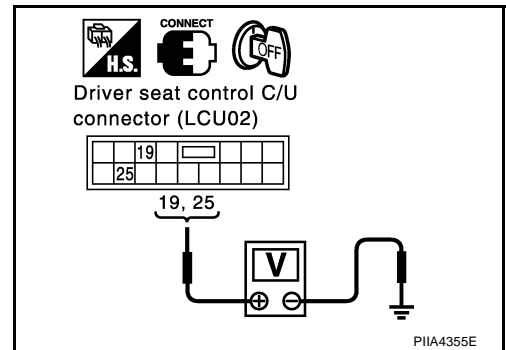

AUTOMATIC DRIVE POSITIONER

3. CHECK HARNESS CONTINUITY

1. Disconnect driver seat control unit connector and power seat switch (driver side) connector.
2. Check continuity between driver seat control unit connector B143 terminals 19 (L/R), 25 (OR/B) and driver seat switch connector B144 terminals 19 (L/R), 25 (OR/B).

19 (L/R) – 19 (L/R) : Continuity should exist.
25 (OR/B) – 25 (OR/B) : Continuity should exist.

3. Check continuity between driver seat control unit connector B143 terminals 19 (L/R), 25 (OR/B) and ground

19 (L/R) – Ground : Continuity should not exist.
25 (OR/B) – Ground : Continuity should not exist.

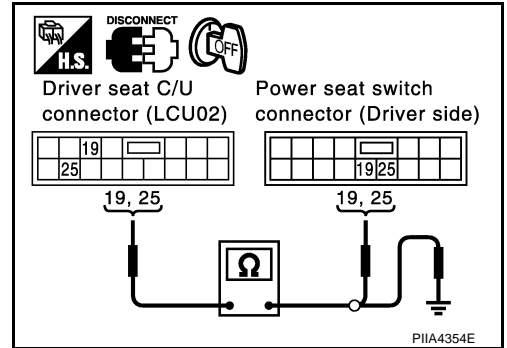

OK or NG

OK >> GO TO 4.

NG >> Repair or replace harness between driver seat control unit and power seat switch (driver side).

4. CHECK FRONT END LIFTING SWITCH

Check continuity between driver seat control unit connector B144 terminal 19, 25 and 15.

Connector	Terminals		Condition	Continuity
B144	19	15	Front lifting switch ON (UP operation).	Yes
			Front lifting switch OFF.	No
	25		Front lifting switch ON (DOWN operation).	Yes
			Front lifting switch OFF.	No

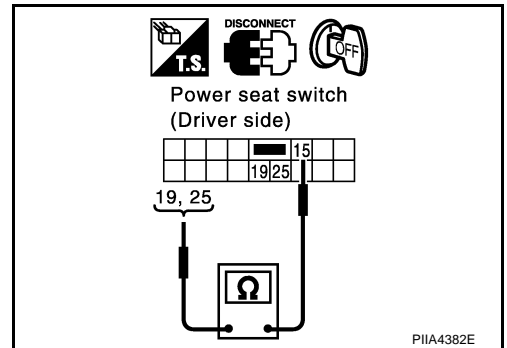

OK or NG

OK >> GO TO 5.

NG >> Replace power seat switch (driver side).

5. CHECK POWER SEAT SWITCH GROUND CIRCUIT

Check continuity between power seat switch connector B144 terminal 15 (B) and ground.

15 (B) – Ground: : Continuity should exist.

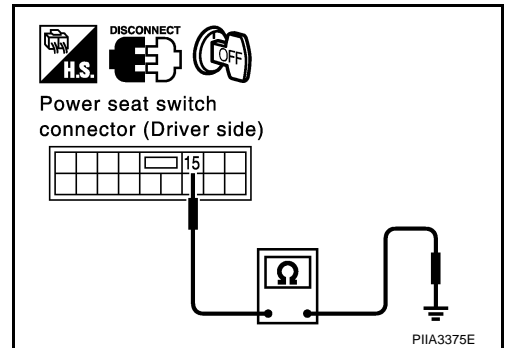

OK or NG

OK >> Check the condition of the harness and connector.

NG >> Repair or replace harness between power seat switch (driver side) and ground.

AUTOMATIC DRIVE POSITIONER

EIS008KU

Rear Lifting Switch Circuit Inspection

1. CHECK FUNCTION

With CONSULT-II

With "LIFT RR SW-UP, LIFT RR SW-DN" on the DATA MONITOR, operate the rear lifting switch to check ON/OFF operation.

Monitor item [OPERATION or UNIT]		Contents
LIFT RR SW-UP	"ON/OFF"	Operation (ON)/open (OFF) status judged from the RR lifter switch (UP) signal is displayed.
LIFT RR SW-DN	"ON/OFF"	Operation (ON)/open (OFF) status judged from the RR lifter switch (DOWN) signal is displayed.

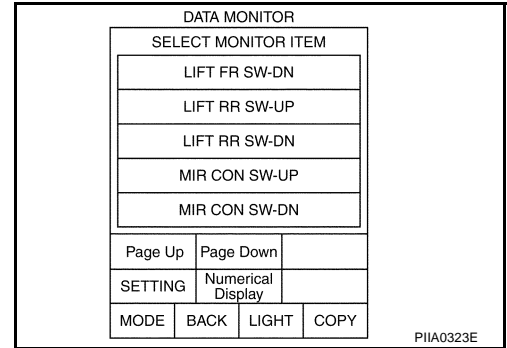

Without CONSULT-II

Carry out "SWITCH MONITOR" in the on-board diagnosis function, and operate the rear lifting switch to check. Refer to [SE-50, "SWITCH MONITOR"](#).

OK or NG

- OK >> Replace the driver seat control unit.
- NG >> GO TO 2.

2. CHECK REAR LIFTING SWITCH INPUT/OUTPUT

1. Turn ignition switch turn OFF.
2. Check voltage between driver seat control unit connector and ground.

Connector	Terminals (Wire color)		Condition	Voltage (V) (Approx.)
	(+)	(-)		
B143	26 (P/B)	Ground	Rear lifting switch ON (UP operation).	0
			Rear lifting switch OFF.	5
	27 (B/Y)		Rear lifting switch ON (DOWN operation).	0
			Rear lifting switch OFF.	5

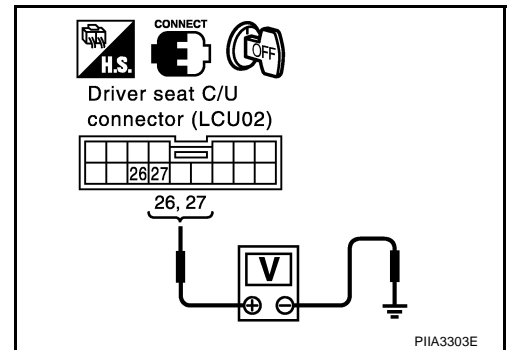

OK or NG

- OK >> System is OK.
- NG >> GO TO 3.

AUTOMATIC DRIVE POSITIONER

3. CHECK HARNESS CONTINUITY

1. Disconnect driver seat control unit connector and driver power seat switch connector.
2. Check continuity between driver seat control unit connector B143 terminals 26 (P/B), 27 (B/Y) and power seat switch (driver side) connector B144 terminals 26 (P/B), 27 (B/Y).

26 (P/B) – 26 (P/B) : Continuity should exist.
27 (B/Y) – 27 (P/Y) : Continuity should exist.

3. Check continuity between driver seat control unit connector B143 terminals 26 (P/B), 27 (B/Y) and ground.

26 (P/B) – Ground : Continuity should not exist.
27 (B/Y) – Ground : Continuity should not exist.

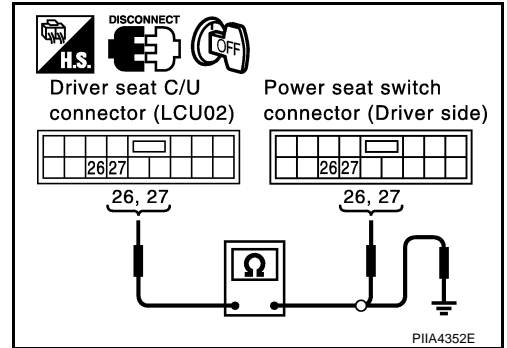

OK or NG

OK >> GO TO 4.

NG >> Repair or replace harness between driver seat control unit and driver power seat switch (driver side).

4. CHECK REAR LIFTING SWITCH

Check continuity between driver seat control unit connector B144 terminal 26, 27 and 15.

Connector	Terminals	Condition	Continuity
B144	26	Rear lifting switch ON(UP operation).	Yes
		Rear lifting switch OFF.	No
	27	Rear lifting switch ON (DOWN operation).	Yes
		Rear lifting switch OFF.	No

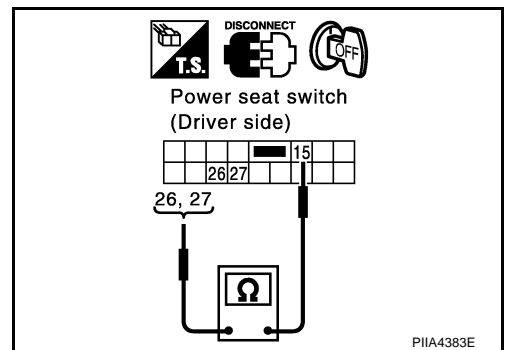

OK or NG

OK >> GO TO 5.

NG >> Replace power seat switch (driver side).

5. CHECK POWER SEAT SWITCH GROUND CIRCUIT

Check continuity between power seat switch connector B144 terminal 15 (B) and ground.

15 (B) – Ground : Continuity should exist.

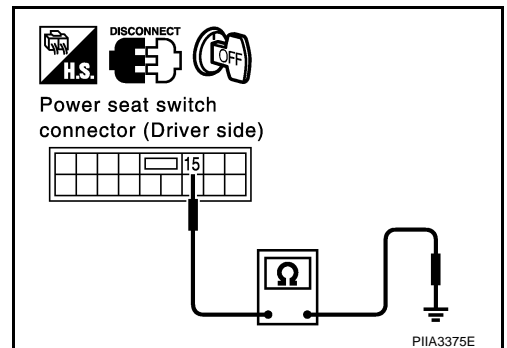

OK or NG

OK >> Check the condition of the harness and connector.

NG >> Repair or replace harness between power seat switch (driver side) and ground.

AUTOMATIC DRIVE POSITIONER

EIS008KV

Telescopic Switch Inspection

1. CHECK FUNCTION

With CONSULT-II

With "TELESCO SW-FR, TELESCO SWRR"RR" on the DATA MONITOR, operate the ADP steering switch to check ON/OFF operation.

Monitor item [OPERATION or UNIT]		Contents
TELESCO SW-FR	"ON/OFF"	Operation (ON)/open (OFF) status judged from the telescoping switch (FR) signal is displayed.
TELESCO SW-RR	"ON/OFF"	Operation (ON)/open (OFF) status judged from the telescoping switch (RR) signal is displayed.

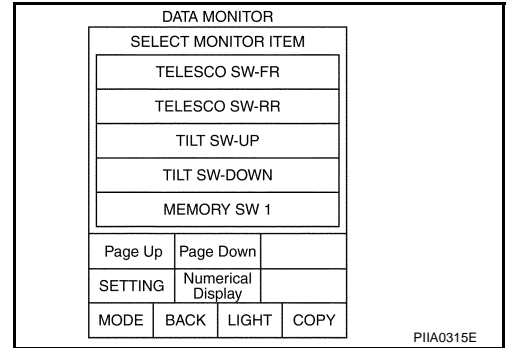

Without CONSULT-II

Carry out "SWITCH MONITOR" in the on-board diagnosis function, and operate the ADP steering switch to check. Refer to [SE-50, "SWITCH MONITOR"](#).

OK or NG

- OK >> System is OK.
- NG >> GO TO 2.

2. CHECK TELESCOPIC SWITCH INPUT/OUTPUT

1. Turn ignition switch OFF.
2. Check voltage between BCM connector and ground.

Connector	Terminals (Wire color)		Condition	Voltage (V) (Approx.)
	(+)	(-)		
M4	22 (R)	Ground	Telescopic switch ON (forward operation).	0
			Telescopic switch OFF.	5
	26 (GY/R)		Telescopic switch ON (backward operation).	0
			Telescopic switch OFF.	5

OK or NG

- OK >> System is OK.
- NG >> GO TO 3.

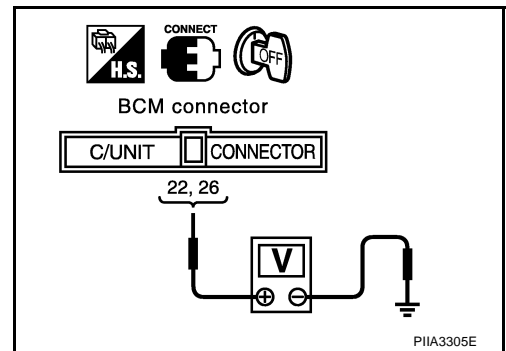

AUTOMATIC DRIVE POSITIONER

3. CHECK HARNESS CONTINUITY

1. Disconnect BCM connector and ADP steering switch connector.
2. Check continuity between BCM connector M4 terminals 22 (R), 26 (GY/R) and ADP steering switch connector M51 terminals 4 (GY/R), 5 (R).

22 (R) – 5 (R) : Continuity should exist.

26 (GY/R) – 4 (GY/R) : Continuity should exist.

3. Check continuity between BCM connector M4 terminals 22 (R), 26 (GY/R) and ground.

22 (R) – Ground : Continuity should not exist.

26 (GY/R) – Ground : Continuity should not exist.

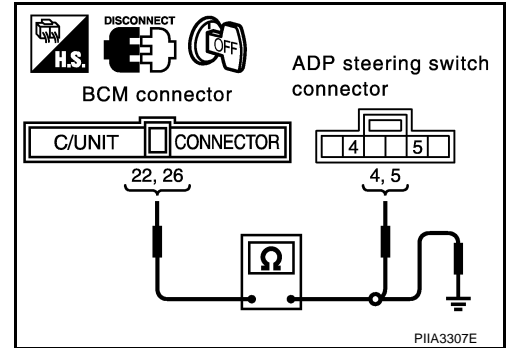

OK or NG

OK >> GO TO 4.

NG >> Repair or replace harness between BCM and ADP steering switch.

4. CHECK TELESCOPIC SWITCH

Check continuity between ADP steering switch connector M51 terminal 4, 5 and 1.

Connector	Terminals	Condition	Continuity
M51	4	Telescopic switch ON (backward operation)	Yes
		Telescopic switch OFF	No
	5	Telescopic switch ON (forward operation)	Yes
		Telescopic switch OFF	No

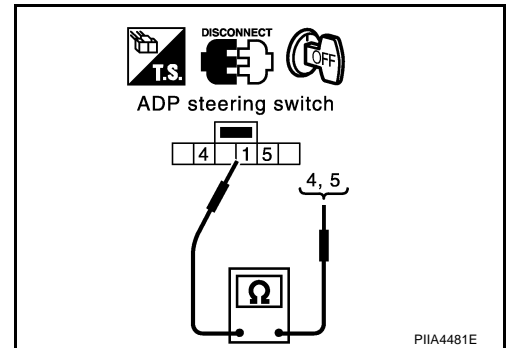

OK or NG

OK >> GO TO 5.

NG >> Replace ADP steering switch.

5. CHECK ADP STEERING SWITCH GROUND CIRCUIT

Check continuity between ADP steering switch connector M51 terminal 1 (B) and ground.

1 (B) – Ground : Continuity should exist.

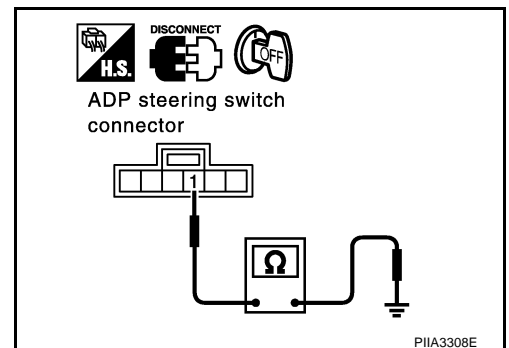

OK or NG

OK >> Check the condition of the harness and connector.

NG >> Replace or replace harness between ADP steering switch and ground.

AUTOMATIC DRIVE POSITIONER

EIS008KW

Tilt Switch Inspection

1. CHECK FUNCTION

With CONSULT-II

With "TILT SW-UP,TILT SW-DOWN" on the DATA MONITOR, operate the ADP steering switch to check ON/OFF operation.

Monitor item [OPERATION or UNIT]		Contents
TILT SW-UP	"ON/OFF"	Operation (ON)/open (OFF) status judged from the tilt switch (UP) signal is displayed.
TILT SW-DOWN	"ON/OFF"	Operation (ON)/open (OFF) status judged from the tilt switch (DOWN) signal is displayed.

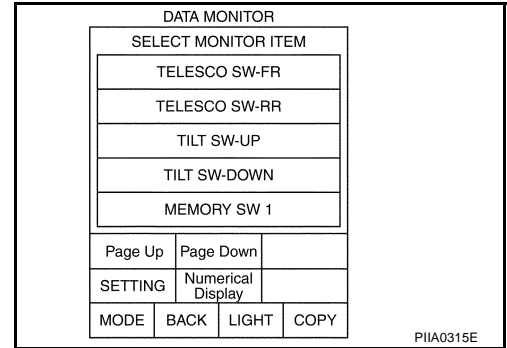

Without CONSULT-II

Carry out "SWITCH MONITOR" in the on-board diagnosis function, and operate the ADP steering switch to check. Refer to [SE-50](#), "SWITCH MONITOR".

OK or NG

- OK >> System is OK.
- NG >> GO TO 2.

2. CHECK ADP STEERING SWITCH (TILT) INPUT/OUTPUT

1. Turn ignition switch turn OFF.
2. Check voltage between BCM connector and ground.

Connector	Terminals (Wire color)		Condition	Voltage (V) (Approx.)
	(+)	(-)		
M4	23 (PU/W)	Ground	Tilt switch ON. (DOWN operation)	0
			Tilt switch OFF.	5
	36 (Y/G)		Tilt switch ON (UP operation).	0
			Tilt switch OFF.	5

OK or NG

- OK >> System is OK.
- NG >> GO TO 3.

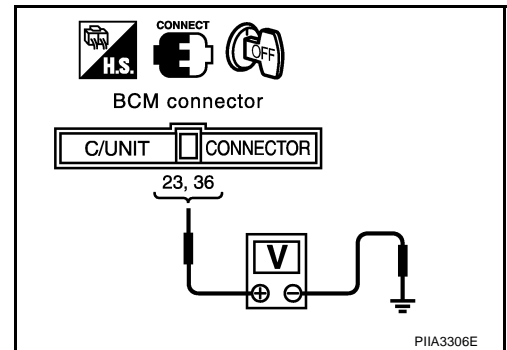

AUTOMATIC DRIVE POSITIONER

3. CHECK HARNESS CONTINUITY

1. Disconnect BCM connector and ADP steering switch connector.
2. Check continuity between BCM connector M4 terminals 23 (PU/W), 36 (Y/G) and ADP steering switch connector M51 terminals 2 (Y/G), 3 (PU/W).

23 (PU/W) – 3 (PU/W) : Continuity should exist.
36 (Y/G) – 2 (Y/G) : Continuity should exist.

3. Check continuity between BCM connector M4 terminals 23 (PU/W), 36 (Y/G) and ground.

23 (PU/W) – Ground : Continuity should not exist.
36 (Y/G) – Ground : Continuity should not exist.

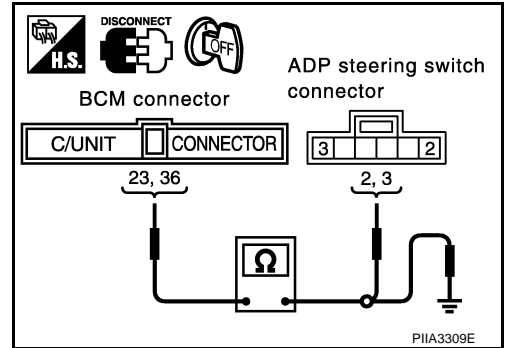

OK or NG

- OK >> GO TO 4.
 NG >> Repair or replace harness between BCM and ADP steering switch.

4. CHECK ADP TILT STEERING SWITCH

Check continuity between ADP steering switch connector M51 terminal 2, 3 and 1.

Connector	Terminals		Condition	Continuity
M51	2	1	Tilt switch ON (UP operation).	Yes
			Tilt switch OFF.	No
	3		Tilt switch ON (DOWN operation).	Yes
			Tilt switch OFF.	No

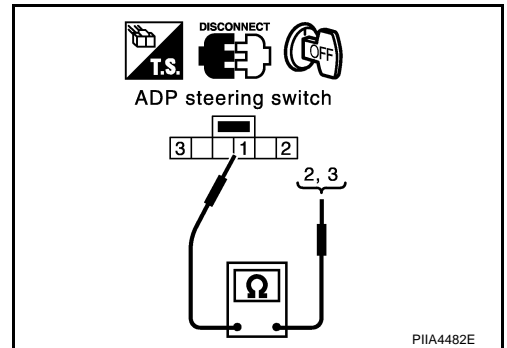

OK or NG

- OK >> GO TO 5.
 NG >> Replace ADP steering switch.

5. CHECK ADP STEERING SWITCH GROUND CIRCUIT

Check continuity between ADP steering switch connector M51 terminal 1 (B) and ground.

1 (B) – Ground : Continuity should exist.

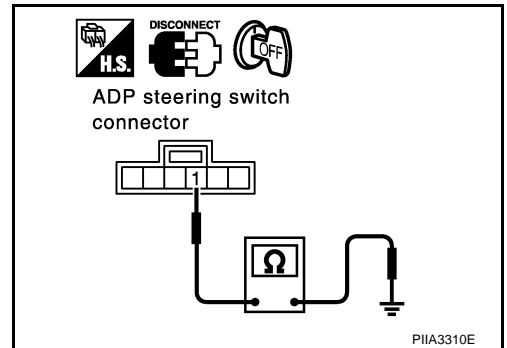

OK or NG

- OK >> Check the harness and connector.
 NG >> Repair or replace harness between ADP steering switch and ground.

AUTOMATIC DRIVE POSITIONER

Seat Memory Indicator lamp System Inspection

EIS008KX

1. CHECK FUNCTION

With CONSULT-II

With "MEMORY SW INDCTR" in ACTIVE TEST, Check operation.

Test item	Description
MEMORY SW INDCTR	The memory switch indicator is lit by receiving the drive signal.

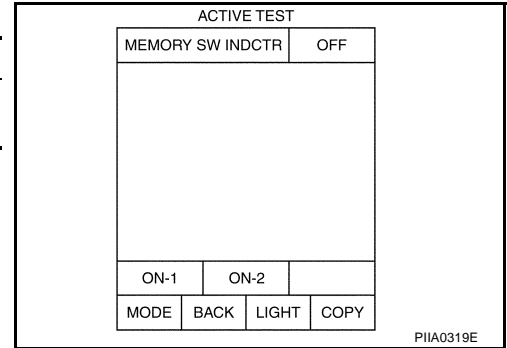

Without CONSULT-II

GO TO 2.

OK or NG

OK >> System is OK.

NG >> GO TO 2.

2. CHECK FUSE

Check 10A fuse [No.3, located in fuse block (J/B)]

NOTE:

Refer to [SE-17, "Component Parts and Harness Connector Location"](#) .

OK or NG

OK >> GO TO 2.

NG >> If fuse is blown, be sure to eliminate cause of malfunction before installing new fuse, refer to [PG-2, "POWER SUPPLY ROUTING"](#) .

3. CHECK SEAT MEMORY SWITCH POWER SUPPLY CIRCUIT

1. Turn ignition switch OFF.
2. Disconnect seat memory switch connector.
3. Check voltage between seat memory switch connector D3 terminal 5 (P/L) and ground.

5 (P/L) – Ground : Battery voltage.

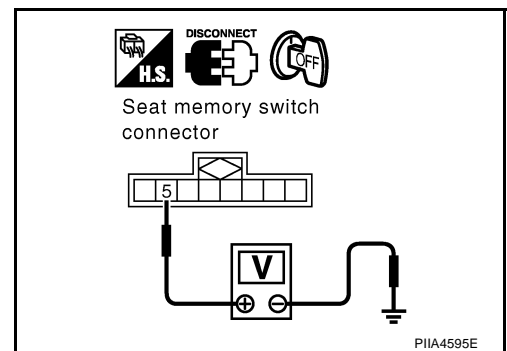

OK or NG

OK >> GO TO 4

NG >> Repair or replace harness between fuse block (J/B) and seat memory switch.

AUTOMATIC DRIVE POSITIONER

4. CHECK HARNESS CONTINUITY

1. Disconnect BCM connector.
2. Check continuity between BCM connector M4 terminals 106 (BR/Y), 112 (L/W) and seat memory switch connector D3 terminals 6 (BR/Y), 7 (L/W).

106 (BR/Y) – 6 (BR/Y) : Continuity should exist.

112 (L/W) – 7 (L/W) : Continuity should exist.

3. Check continuity between BCM connector M4 terminals 106 (BR/Y), 112 (L/W) and ground.

106 (BR/Y) – Ground : Continuity should not exist.

112 (L/W) – Ground : Continuity should not exist.

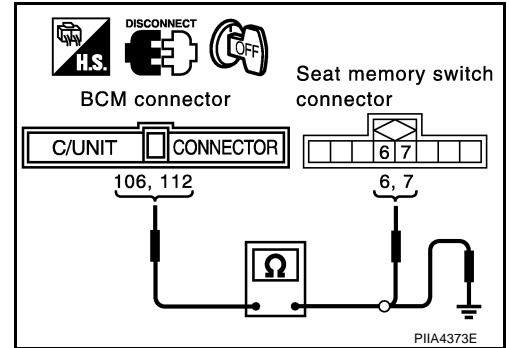

OK or NG

OK >> GO TO 5.

NG >> Repair or replace harness between BCM and memory switch.

5. CHECK SEAT MEMORY SWITCH INDICATOR SIGNAL

Check voltage between BCM connector M4 terminals 106 (BR/Y), 112 (L/W) and ground.

106 (BR/Y) – Ground : Battery voltage.

112 (L/W) – Ground : Battery voltage.

OK or NG

OK >> Replace BCM.

NG >> Replace seat memory switch.

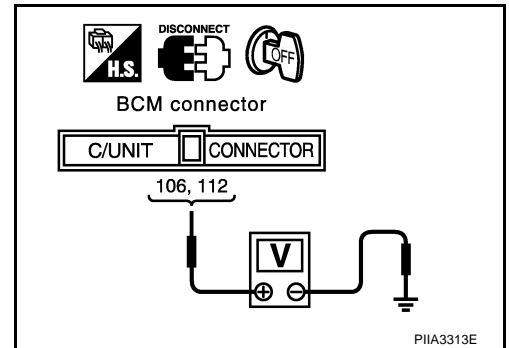

Lumber Support Circuit Inspection

1. CHECK LUMBER SUPPORT SWITCH

1. Turn ignition switch OFF.
2. Disconnect front power seat switch (driver side) connector.
3. Check voltage between power seat switch (driver side) connector B144 terminal 16 (R) and ground.

16 (R) – Ground: : Battery voltage.

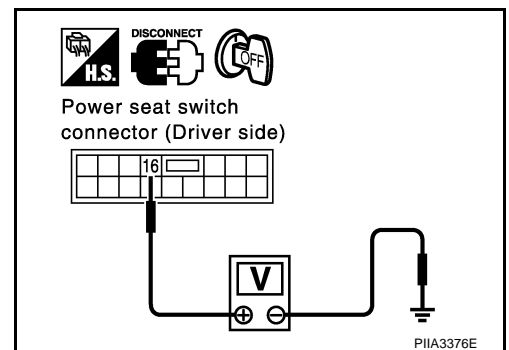

OK or NG

OK >> GO TO 2.

NG >> Repair or replace harness between fuse block (J/B) and power seat switch (Driver side).

AUTOMATIC DRIVE POSITIONER

2. CHECK LUMBER SUPPORT SWITCH

Check continuity power seat switch connector B144 terminal 14, 16 and 3 or 5.

Connector	Terminal	Condition	Continuity
B144	3	16	Lumber support switch forward.
		14	Lumber support switch backward.
	5	16	Lumber support switch backward.
		14	Lumber support switch forward.

OK or NG

OK >> GO TO 3.

NG >> The harness and connector is checked, and it is normal, replace power seat switch.

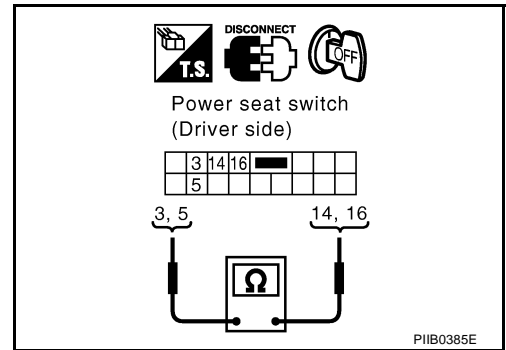

3. CHECK LUMBER SUPPORT MOTOR HARNESS

1. Disconnect lumber support motor connector.
2. Check continuity between power seat switch connector (driver side) B144 terminal 3 (GY), 5 (W/B) and lumber support motor connector B145 terminal 3 (GY), 5 (W/B).

3 (GY) – 3 (GY) :Continuity should exist.

5 (W/B) – 5 (W/B) :Continuity should exist.

3. Check continuity between power seat switch connector (driver side) B144 terminal 3 (GY), 5 (W/B) and ground.

3 (GY) – Ground :Continuity should not exist.

5 (W/B) – Ground :Continuity should not exist.

OK or NG

OK >> GO TO 4.

NG >> Repair or replace harness between power seat switch (driver side) and lumber support motor.

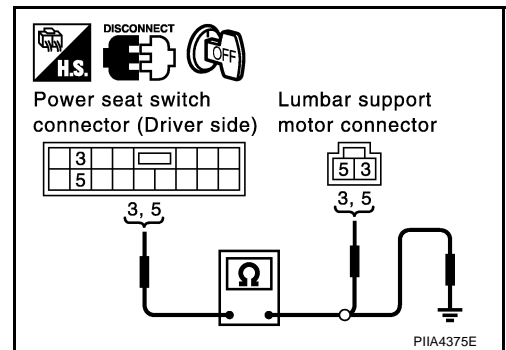

4. LUMBER SUPPORT SWITCH INSPECTION

Check continuity between power seat switch connector (driver side) B144 terminal 14 (B/W) and ground.

14 (B/W) – Ground : Continuity should exist.

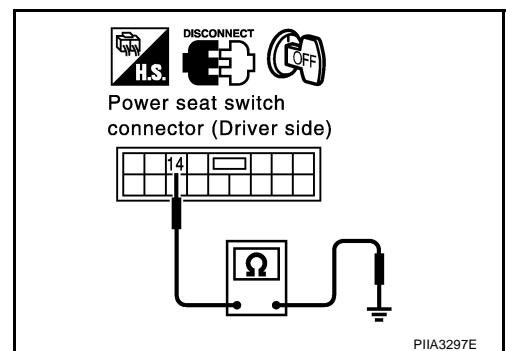

OK or NG

OK >> Check harness and connector.

NG >> Repair or replace harness between power seat switch (driver side) and ground.

AUTOMATIC DRIVE POSITIONER

Rear Power Seat Turnout Operation Inspection

EIS008KZ

1. CHECK REAR POWER SEAR CONDITION

Front power window main switch operation normally when the power window is operated?

OK or NG

OK >> GO TO 2.

NG >> Check the power window system [GW-16, "POWER WINDOW SYSTEM"](#) .

2. CHECK REAR POWER SEAT CONTROL UNIT HARNESS

1. Turn ignition switch OFF.
2. Disconnect rear LH door control unit connector and rear power seat control unit LH connector.
3. Check continuity between rear LH door control unit connector B163 terminal 18 (BR/W) and rear power seat control unit LH connector D58 terminal 12 (OR/L).

18 (BR/W) – 12 (OR/L) :Continuity should exist.

4. Check continuity between rear LH door control unit connector B163 terminal 18 (BR/W) and ground.

18 (BR/W) – Ground :Continuity should not exist.

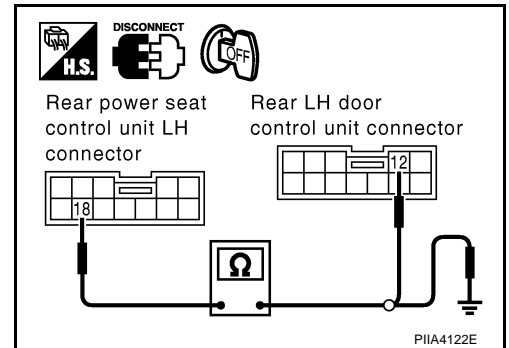

OK or NG

OK >> GO TO 3.

NG >> Repair or replace harness between rear LH door control unit and rear power seat control unit LH.

3. CHECK REAR POWER SEAT AUTO RETURN SIGNAL

1. Connect rear power seat control unit LH connector.
2. Check voltage between rear LH door control unit connector and ground.

Connector	Terminals (Wire color)		Condition	Voltage (V) (Approx.)
	(+)	(-)		
D58	12 (OR/L)	Ground	Driver side seat auto return operation (back ward)	0
			When driver side seat auto return stops	Battery voltage

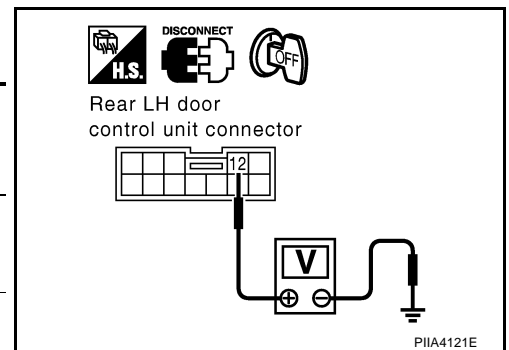

OK or NG

OK >> Replace rear power seat control unit LH.

NG >> Replace rear LH door control unit.

POWER SEAT

System Description

E/IS008L0

The rear power seat (LH / RH) retreats when the auto return cancel switch is turned on and each door is opened.

When the slide switch turned on, or auto return cancel switch is canceled, an auto return is discontinued.

The LH seat moves backward when the driver seat is moved backward by the auto driving position system.

Refer to [SE-13. "System Description"](#) .

Power is all times supplied

- through 40A fusible link [letter H, located in the fuse block (J/B)],
- to front power seat passenger side terminal 16, and
- to rear power seat control unit LH, rear power seat control unit RH terminal 2.

FRONT POWER SEAT (PASSENGER SIDE) OPERATION

When sliding switch is forward, power is supplied

- through power seat switch terminal 1,
- to sliding motor terminal 1.

Then ground is supplied

- to sliding motor terminal 8,
- through power seat switch terminal 8,
- through power seat switch terminal 15A,
- through body grounds B217 and B256.

When power and ground are supplied, front passenger seat slide moves forward.

When sliding switch is backward, power is supplied

- through power seat switch terminal 8,
- to sliding motor terminal 8.

Then ground is supplied

- to sliding motor terminal 1,
- through power seat switch terminal 1,
- through power seat switch terminal 15A,
- through body grounds B217 and B256.

When power and ground are supplied, front passenger seat slide moves backward.

When reclining switch is forward, power is supplied

- through power seat switch terminal 2,
- to reclining motor terminal 2.

Then ground is supplied

- to reclining motor terminal 9,
- through power seat switch terminal 9,
- through power seat switch terminal 15A,
- through body grounds B217 and B256.

When power and ground are supplied, front passenger seat reclining moves forward.

When reclining switch is backward, power is supplied

- through power seat switch terminal 9,
- to reclining motor terminal 9.

Then ground is supplied

- to reclining motor terminal 2,
- through power seat switch terminal 2,
- through power seat switch terminal 15A,
- through body grounds B217 and B256.

When power and ground are supplied, front passenger seat reclining moves backward.

This seat does reclining backward.

When front lifting switch is upward, power is supplied

POWER SEAT

- through power seat switch terminal 11,
- to front lifting motor terminal 11.

Then ground is supplied

- to front lifting motor terminal 10,
- through power seat switch terminal 10,
- through power seat switch terminal 15A,
- through body grounds B217 and B256.

When power and ground are supplied, front passenger seat front lifting moves upward.
This seat does front lifting upward.

When front lifting switch is downward, power is supplied

- through power seat switch terminal 10,
- to front lifting motor terminal 10.

Then ground is supplied

- to front lifting motor terminal 11,
- through power seat switch terminal 11,
- through power seat switch terminal 15A,
- through body grounds B217 and B256.

When power and ground are supplied, front passenger seat front lifting moves downward.
This seat does front lifting downward.

When rear lifting switch is upward, power is supplied

- through power seat switch terminal 6,
- to rear lifting motor terminal 6.

Then ground is supplied

- to rear lifting motor terminal 4,
- through power seat switch terminal 4,
- through power seat switch terminal 15A,
- through body grounds B217 and B256.

When power and ground are supplied, front passenger seat rear lifting moves upward.

When rear lifting switch is downward, power is supplied

- through power seat switch terminal 4,
- to rear lifting motor terminal 4.

Then ground is supplied

- to rear lifting motor terminal 6,
- through power seat switch terminal 6,
- through power seat switch terminal 15A,
- through body grounds B217 and B256.

When power and ground are supplied, front passenger seat rear lifting moves downward.

REAR POWER SEAT LH AND REAR POWER SEAT RH OPERATION

When rear power seat sliding switch is forward, ground is supplied

- to rear power seat control unit terminal 24,
- through power seat switch terminal 7 (RH), 8 (LH),
- through power seat switch terminal 2,
- through body grounds B17, B57 (LH) and B217, B256 (RH).

When rear power seat control unit receives sliding switch forward signal, power is supplied

- through rear power seat control unit terminal 4,
- to rear power seat sliding motor terminal 4.

Then ground is supplied

- to rear power seat sliding motor terminal 11,
- through rear power seat control unit terminal 11,

A

B

C

D

E

F

G

H

SE

J

K

L

M

POWER SEAT

- through rear power seat control unit terminals 15,
- through body grounds B17, B57 (LH) B217, B256 (RH).

When power and ground are supplied, rear power seat slide moves forward.
This seat does slide forward.

When rear power seat sliding switch is backward, ground is supplied

- to rear power seat control unit terminal 18,
- through power seat switch terminal 7 (LH), 8 (RH),
- through power seat switch terminal 2,
- through body grounds B17, B57 (LH) and B217, B256 (RH).

When rear power seat control unit receives sliding switch backward signal, power is supplied

- to rear power seat sliding motor terminal 11,
- through rear power seat control unit terminal 11.

Then ground is supplied

- to rear power seat sliding motor terminal 4,
- through rear power seat control unit terminal 4,
- through rear power seat control unit terminals 15,
- through body grounds B17, B57 (LH) and B217, B256 (RH).

When power and ground are supplied, rear power seat slide moves backward.

REAR SEAT TURNOUT/RETURN FUNCTION

When auto return cancel switch ON and rear door open, ground is supplied

- to rear power seat control unit terminal 43,
- through door lock assembly rear (Door switch) terminal 1,
- through door lock assembly rear (Door switch) terminal 2,
- through body grounds B17, B57 (LH) and B217, B256 (RH).

When rear power seat control unit receives rear door switch open signal, power is supplied

- through rear power seat control unit terminal 11,
- to rear power seat sliding motor terminal 11.

Then ground is supplied

- to rear power seat sliding motor terminal 4,
- through rear power seat control unit terminal 4,
- through rear power seat control unit terminals 15,
- through body grounds B17, B57 (LH) and B217, B256 (RH).

When power and ground are supplied, rear power seat slide moves backward.

When rear power seat sliding motor is operated, ground is supplied

- to rear power seat control unit terminal 21,
- through rear power seat sliding motor terminal 21,
- through rear power seat sliding motor terminal 74,
- through rear power seat control unit terminal 74,
- through rear power seat control unit terminals 28,
- through body grounds B17, B57 (LH) and B217, B256 (RH).

Then power seat control unit receives rear power seat sliding sensor signal.

The rear power seat control unit controls the seat position of the system operation with the signal.

POWER SEAT

Component Parts and Harness Connector Location

EIS008L1

A
B
C
D
E
F
G
H
SE
J
K
L
M

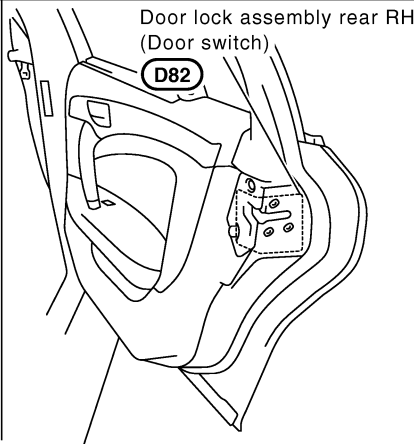
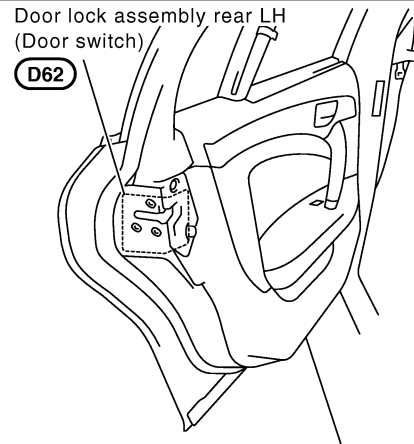
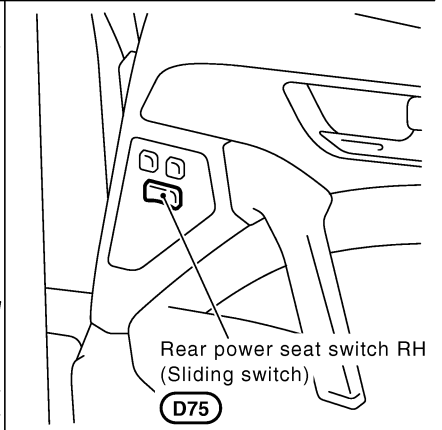
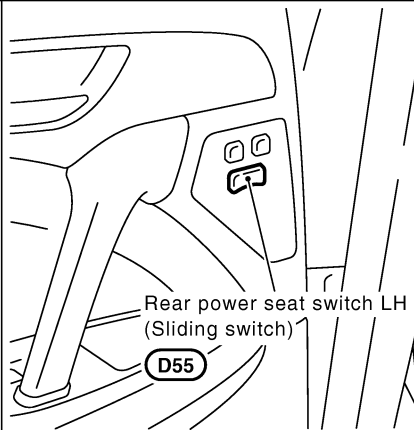
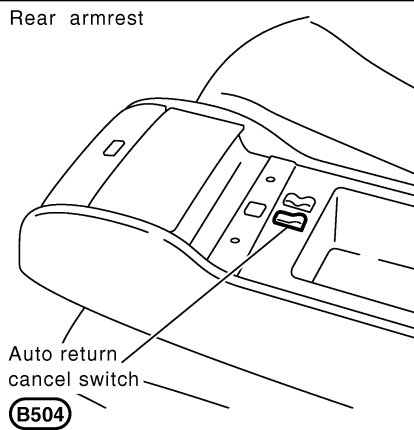
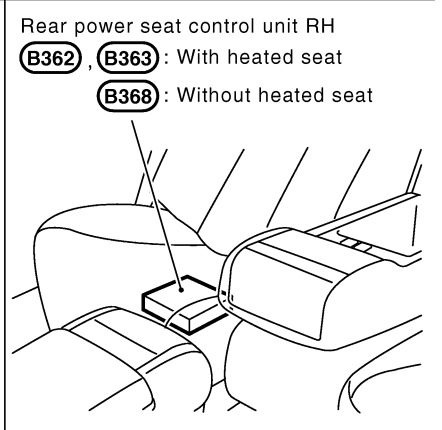
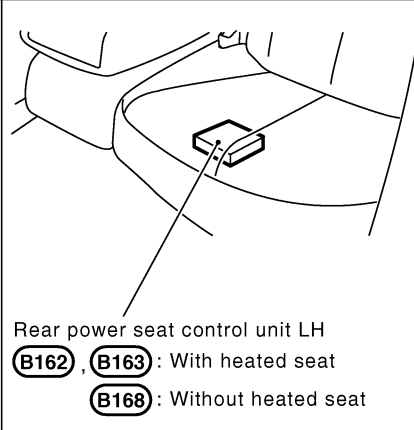
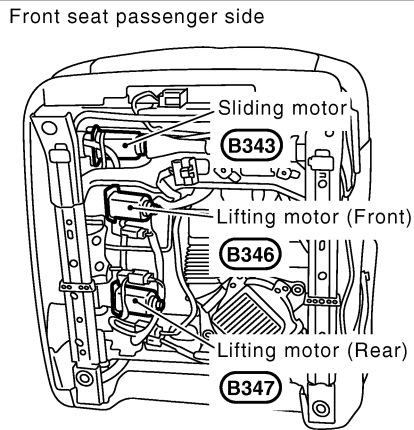
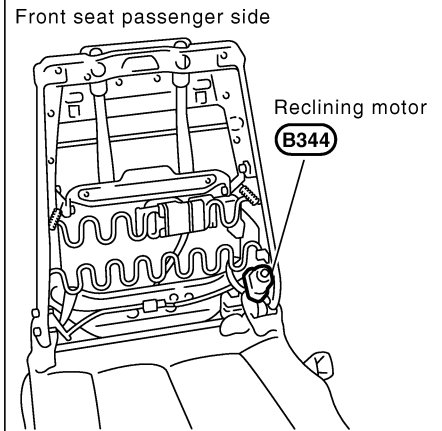
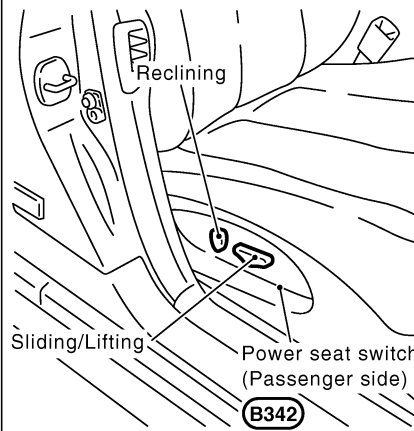
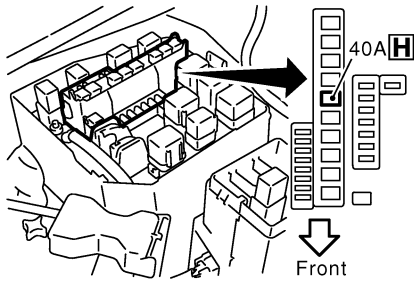

PIIA3389E

POWER SEAT

Schematic

E/IS008L2

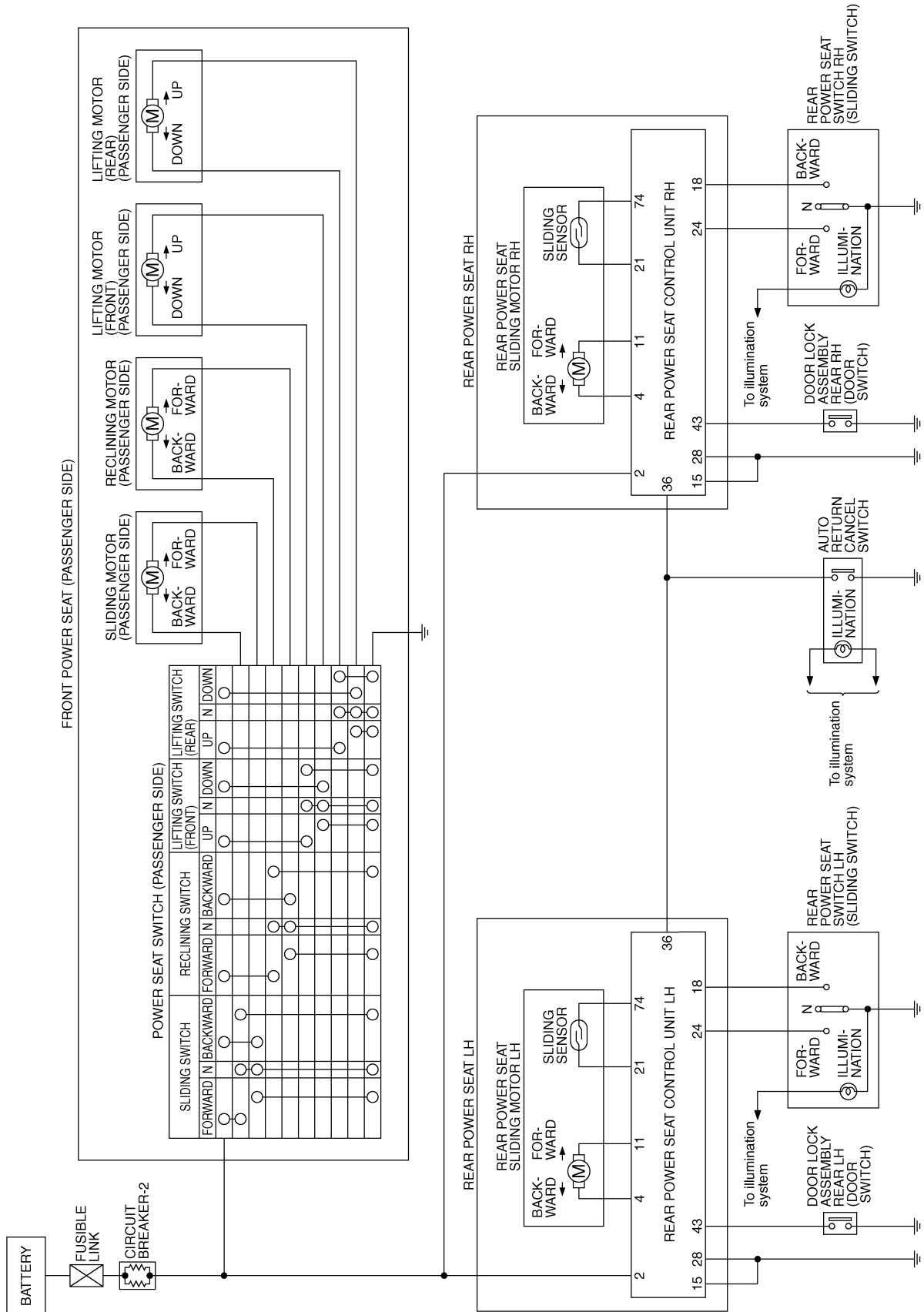

TIWM0733E

POWER SEAT

SE-SEAT-02

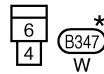
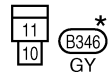
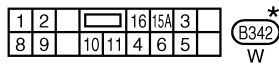
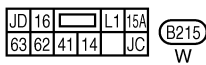
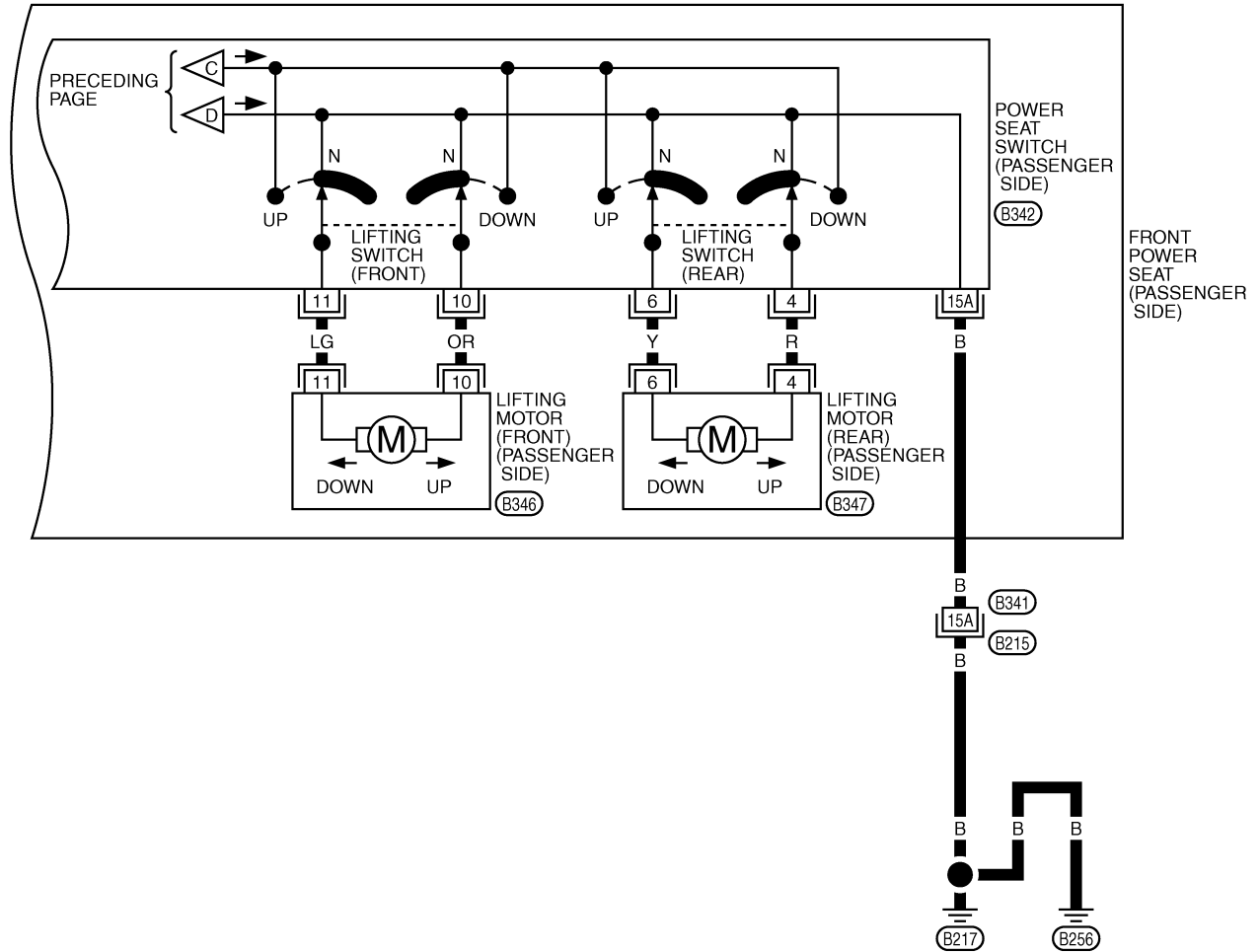

*: THIS CONNECTOR IS NOT SHOWN IN "HARNESS LAYOUT", PG SECTION.

TIWM0735E

POWER SEAT

SE-SEAT-06

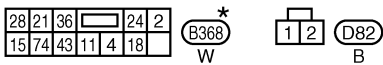
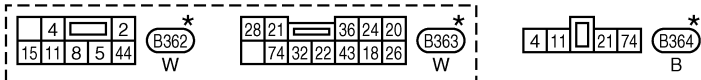
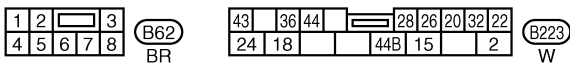
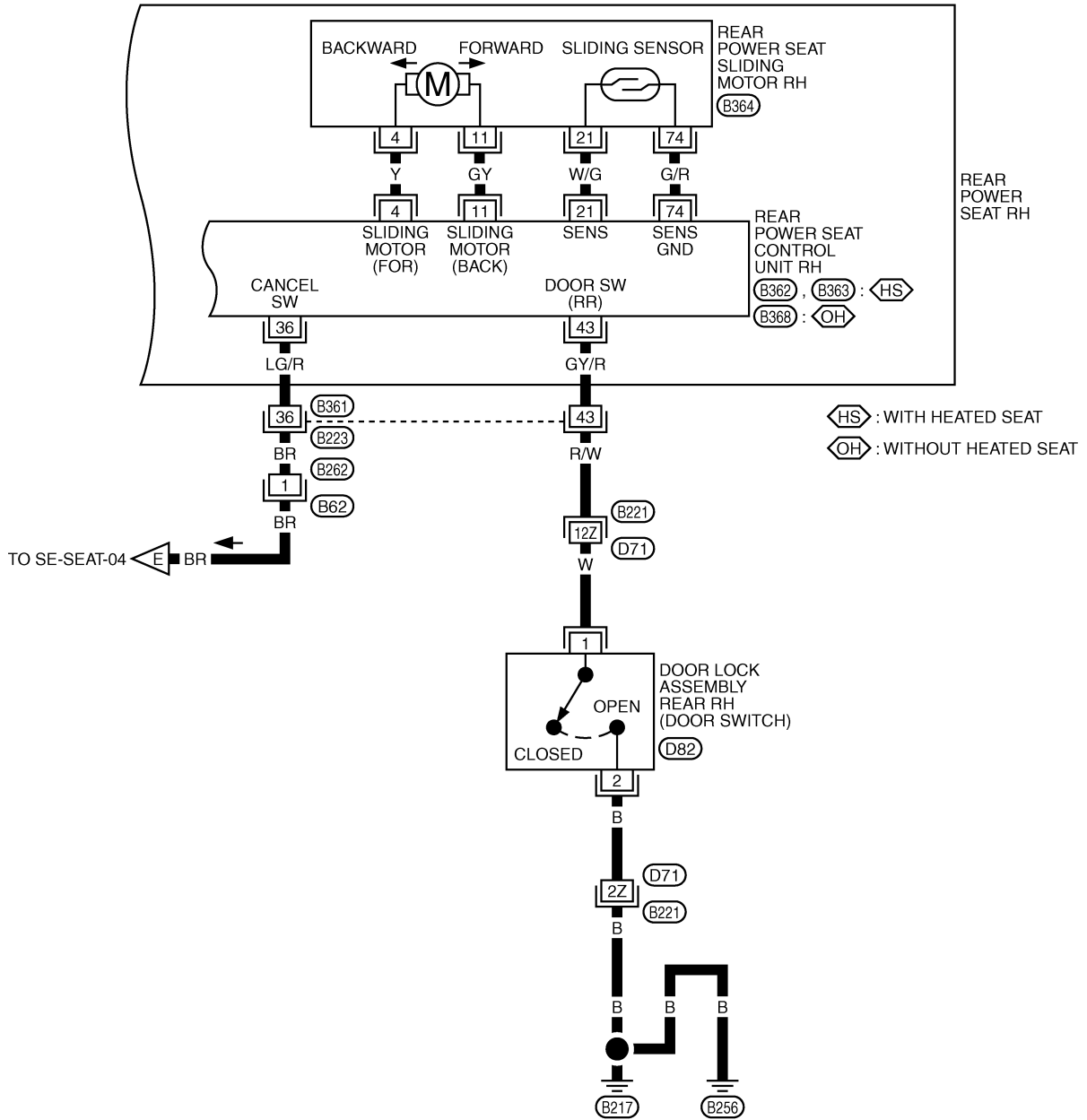

*: THIS CONNECTOR IS NOT SHOWN IN "HARNESS LAYOUT", PG SECTION.

REFER TO THE FOLLOWING.
 (B221) -SUPER MULTIPLE JUNCTION (SMJ)

TIWM0739E

POWER SEAT

Terminals and Reference Values for Passenger Side Power Seat Switch

EIS008L4

TERMINAL	WIRE COLOR	ITEM	CONDITION	Voltage (V) (Approx.)
1	W	Sliding motor forward signal	When sliding switch forward is operated	Battery voltage
			Other than above	0
2	G	Reclining motor forward signal	When reclining switch forward is operated	Battery voltage
			Other than above	0
4	R	Rear lifting switch DOWN signal	When rear lifting switch DOWN is operated	Battery voltage
			Other than above	0
6	Y	Rear lifting switch UP signal	When rear lifting switch UP is operated	Battery voltage
			Other than above.	0
8	B/W	Sliding motor backward signal	When sliding switch backward is operated	Battery voltage
			Other than above	0
9	PU	Reclining motor backward signal	When reclining switch backward is operated.	Battery voltage
			Other than above	0
10	OR	Front lifting switch DOWN signal	When front lifting switch DOWN is operated	Battery voltage
			Other than above	0
11	LG	Front lifting switch UP signal	When front lifting switch UP is operated.	Battery voltage
			Other than above	0
15A	B	Ground	—	0
16	P	BAT power supply	—	Battery voltage

Terminals and Reference Values for Rear Power Seat Control Unit

EIS008L5

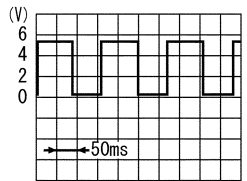
TERMINAL	WIRE COLOR	ITEM	CONDITION	Voltage (V) (Approx.)
2	G	BAT power supply	—	Battery voltage
4	Y	Sliding motor forward signal	When sliding switch forward is operated	Battery voltage
			Other than above	0
11	GY	Sliding motor backward signal	When sliding switch backward is operated	Battery voltage
			Other than above	0
15	B	Ground	—	0
18	BR/W	Sliding switch backward signal	When sliding switch backward is operated.	0
			Other than above	Battery voltage
21	W/G	Sliding sensor signal	Sliding device active	 <small>SIIA0690J</small>
			Sliding device inactive	0 or 5
24	L/G	Sliding switch forward signal	When sliding switch forward is operated.	0
			Other than above.	Battery voltage
28	G/B	Ground	—	0

POWER SEAT

TERMINAL	WIRE COLOR	ITEM	CONDITION	Voltage (V) (Approx.)
36	LG/R	Cancel switch signal	Cancel switch ON with rear door (LH) open	5
			Cancel switch ON with rear door (LH) close	0
			Cancel switch CANCEL	0
43	GY/R	Rear door switch (LH) signal	Rear door (LH) open (ON)	0
			Rear door (LH) close (OFF)	Battery voltage
74	G/R	Ground (sensor system)	—	0

Work Flow

E/IS00BL7

1. Check the symptom and customer's requests.
2. Understand the outline of system. Refer to [SE-94, "System Description"](#) .
3. According to the trouble diagnosis chart, repair or replace the cause of the malfunction. Refer to [SE-106, "Trouble Diagnoses Symptom Chart"](#) .
4. Does power seat operate normally? YES: GO TO 5, NO: GO TO 4.
5. INSPECTION END.

Trouble Diagnoses Symptom Chart

E/IS00BL8

- Check that other systems using the signal of the following systems operate normally.

Symptom	Diagnoses / service procedure	Refer to page
Front power seat passenger side and rear power seat LH, RH do not operate.	Power seat power supply circuit inspection	SE-108
Front power seat passenger side does not operate, but rear power seat is operated.	Front power seat passenger side power supply circuit inspection	SE-108
Front power seat passenger side does not do the sliding.	Front power seat passenger side sliding circuit inspection	SE-109
Front power seat passenger side does not do the reclining.	Front power seat passenger side reclining circuit inspection	SE-110
Front power seat passenger side front does not do the front lifting.	Front power seat passenger side front rifting circuit inspection	SE-111
Front power seat passenger side rear does not do the rear lifting.	Front power seat passenger side rear rifting circuit inspection	SE-112
Rear power seat LH or RH sliding switch does not operate moreover, does not turnout/return function if the door is opened. (With heated seat)	1. Rear power seat power supply ground circuit inspection (With heated seat)	SE-112
	2. Rear power seat sliding motor circuit inspection (With heated seat)	SE-113
	3. Replace rear power seat sliding motor	—
Rear power seat LH or RH does not operate but turnout/return function when the door is opened. (With heated seat)	Rear power seat switch circuit inspection (With heated seat)	SE-114
Rear power seat LH and RH turnout/return function do not operate but operate in sliding switch. (With heated seat)	Auto return cancel switch circuit inspection 2 (With heated seat)	SE-116
Rear power seat LH or RH turnout/return function does not operated but operates by a sliding switch. (With heated seat)	1. Rear door switch circuit inspection (With heated seat)	SE-117
	2. Auto return cancel switch circuit inspection 1 (With heated seat)	SE-116
	3. Rear power seat sliding sensor circuit inspection (With heated seat)	SE-119
	4. Replace rear power seat control unit	—

POWER SEAT

Symptom	Diagnoses / service procedure	Refer to page	
Rear power seat LH or RH sliding switch does not operate moreover, turnout/return function does not operate if the door is opened (Without heated seat)	1. Rear power seat power supply and ground circuit inspection (Without heated seat)	SE-120	A
	2. Rear power seat sliding motor circuit inspection (Without heated seat)	SE-120	B
	3. Replace rear power seat sliding motor	—	
Rear power seat LH or RH does not operate but turnout/return function operates when the door is opened (Without heated seat)	Rear power seat switch circuit inspection (Without heated seat)	SE-121	C
Rear power seat LH and RH turnout/return function do not operate, but the operate by sliding switch (Without heated seat)	Auto return cancel switch circuit inspection 2 (Without heated seat)	SE-123	D
Rear power seat LH or RH turnout/return function does not operate, but operates by a sliding switch (Without heated seat)	1. Rear door switch circuit inspection (Without heated seat)	SE-124	E
	2. Auto return cancel switch circuit inspection 1 (Without heated seat)	SE-123	
	3. Rear power seat sliding sensor circuit inspection (Without heated seat)	SE-126	F
	4. Replace rear power seat control unit.	—	G
			H
			SE
			J
			K
			L
			M

POWER SEAT

E/S008L9

Power Seat Switch Circuit Inspection

1. CHECK FUSIBLE LINK

Check 40A fusible link (letter H located in the fuse and fusible link box).

NOTE:

Refer to [SE-97, "Component Parts and Harness Connector Location"](#).

OK or NG

OK >> GO TO 2.

NG >> If fuse is blown, be sure to eliminate cause of malfunction before installing new fuse, refer to [PG-2, "POWER SUPPLY ROUTING"](#).

2. CHECK POWER SEAT POWER SUPPLY CIRCUIT

1. Turn ignition switch OFF.
2. Disconnect front power seat passenger side switch connector.
3. Check voltage between front power seat passenger side switch connector B342 terminal 16 (P) and ground.

16 (P) – Ground

: Battery voltage

OK or NG

OK >> Check the condition of the harness and connector.

NG >> Repair or replace harness between fuse and fusible link box and front power seat passenger side switch.

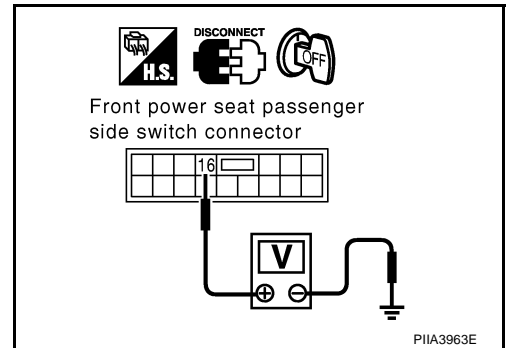

Front Power Seat Passenger Side Power Supply Circuit Inspection

E/S008LA

1. CHECK FRONT POWER SEAT PASSENGER SIDE POWER SUPPLY CIRCUIT

1. Turn ignition switch OFF.
2. Disconnect front power seat passenger side switch connector.
3. Check voltage between front power seat passenger side switch connector B342 terminal 16 (P) and ground.

16 (P) – Ground

: Battery voltage

OK or NG

OK >> GO TO 2.

NG >> Repair or replace harness between fuse and fusible link box and front power seat passenger side switch.

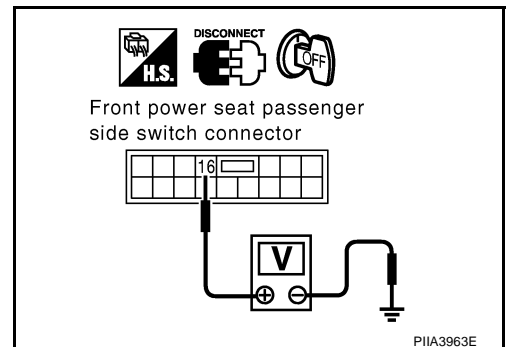

POWER SEAT

2. CHECK POWER SEAT SWITCH

1. Connect front power seat passenger side switch connector.
2. Check continuity between front power seat passenger side switch connector.

Terminal	Condition	Continuity	
16	15A	Sliding switch turn forward and backward.	Yes
	15A	Reclining switch turn forward and backward.	Yes
	15A	Lifting switch (front) fully up and fully down.	Yes
	15A	Lifting switch (rear) fully up and fully down.	Yes
	15A	Other than above	No

OK or NG

- OK >> GO TO 3.
 NG >> Replace front power seat passenger side switch.

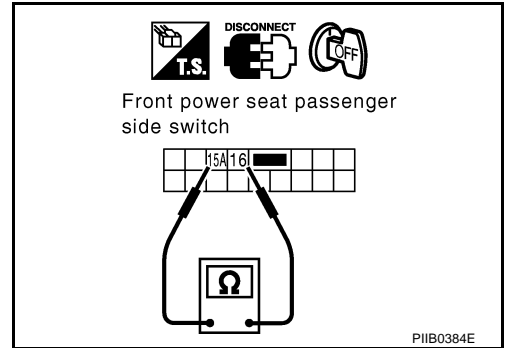

3. CHECK FRONT POWER SEAT PASSENGER SIDE GROUND CIRCUIT

1. Disconnect front power seat passenger side switch connector.
2. Check continuity between front power seat passenger side switch connector B342 terminal 15A (B) and ground.

15A (B) – Ground :Continuity should exist.

OK or NG

- OK >> Check connector.
 NG >> Repair or replace harness between front power seat passenger side switch and ground.

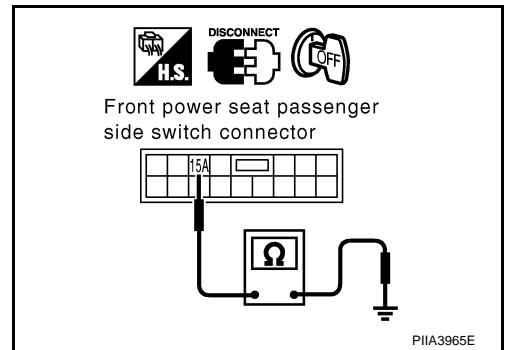

Front Power Seat (Passenger Side) Sliding Circuit Inspection

1. CHECK POWER SEAT SWITCH

1. Turn ignition switch OFF.
2. Disconnect front power seat (passenger side) switch connector.
3. Check continuity between front power seat passenger side switch as follows.

Terminal	Condition	Continuity	
1	15A	Sliding switch backward.	Yes
	16	Sliding switch forward.	Yes
	15A, 16	Other than above.	No
8	15A	Sliding switch forward.	Yes
	16	Sliding switch backward.	Yes
	15A, 16	Other than above.	No

OK or NG

- OK >> GO TO 2.
 NG >> Replace front power seat passenger side switch.

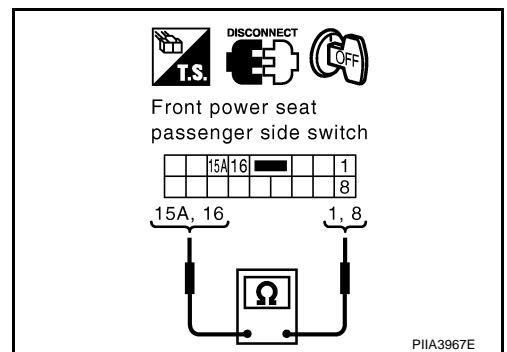

POWER SEAT

2. CHECK SLIDING MOTOR HARNESS

1. Disconnect sliding motor connector.
2. Check continuity between front power seat passenger side switch connector B342 terminals 1 (W), 8 (B/W) and body sliding motor connector B343 terminals 1 (W), 8 (B/W).

1 (W) – 1 (W) :Continuity should exist.
8 (B/W) – 8 (B/W) :Continuity should exist.

3. Check continuity between front power seat passenger side switch connector B342 terminal 1 (W), 8 (B/W) and ground.

1 (W) – Ground :Continuity should not exist.
8 (B/W) – Ground :Continuity should not exist.

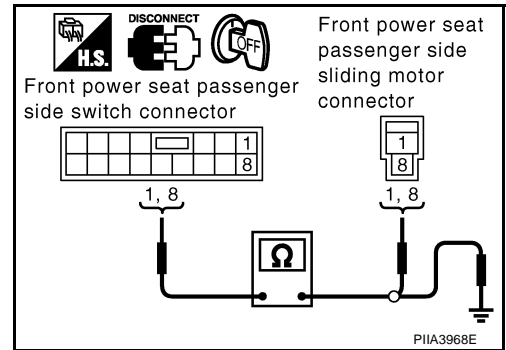

OK or NG

OK >> Replace sliding motor.

NG >> Repair or replace harness between front power seat passenger side switch and sliding motor.

Front Power Seat Passenger Side Reclining Circuit Inspection

E/S008LC

1. CHECK POWER SEAT SWITCH

1. Turn ignition switch OFF.
2. Disconnect front power seat passenger side switch connector.
3. Check continuity between front power seat passenger side switch as follows.

Terminal	Condition	Continuity	
2	15A	Reclining switch backward.	Yes
	16	Reclining switch forward.	Yes
	15A, 16	Other than above	No
9	15A	Reclining switch forward.	Yes
	16	Reclining switch backward.	Yes
	15A, 16	Other than above	No

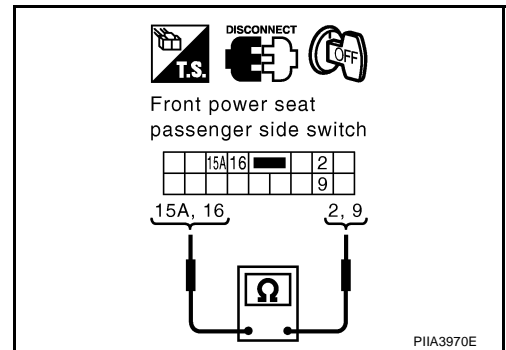

OK or NG

OK >> GO TO 2.

NG >> Replace front power seat passenger side switch.

2. CHECK RECLINING MOTOR HARNESS

1. Disconnect reclining motor connector.
2. Check continuity between front power seat passenger side switch connector B342 terminals 2 (G), 9 (PU) and reclining motor connector B344 terminals 2 (G), 9 (PU).

2 (G) – 2 (G) :Continuity should exist
9 (PU) – 9 (PU) :Continuity should exist

3. Check continuity between front power seat passenger side switch connector B342 terminals 2 (G), 9 (PU) and ground.

2 (G) – Ground :Continuity should not exist
9 (PU) – Ground :Continuity should not exist

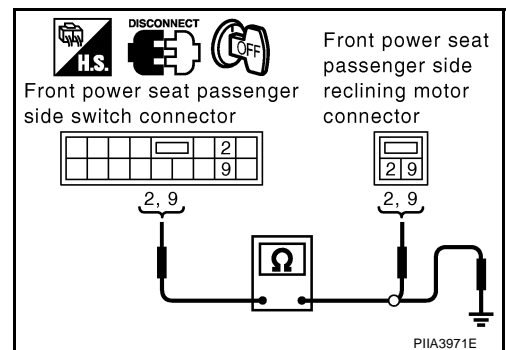

OK or NG

OK >> Replace reclining motor.

NG >> Repair or replace harness between front power seat passenger side switch and reclining motor.

POWER SEAT

Front Power Seat Passenger Side Front Lifting Circuit Inspection

EIS008LD

1. CHECK POWER SEAT SWITCH

1. Turn ignition switch OFF.
2. Disconnect front power seat passenger side switch connector.
3. Check continuity between front power seat passenger side switch as follows.

Terminal		Condition	Continuity
10	15A	Front lifting switch up.	Yes
	16	Front lifting switch down.	Yes
	15A, 16	Other than above	No
11	15A	Front lifting switch down.	Yes
	16	Front lifting switch up.	Yes
	15A, 16	Other than above	No

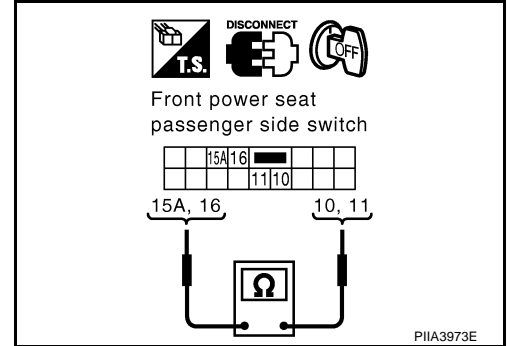

OK or NG

- OK >> GO TO 2.
 NG >> Replace front power seat passenger side switch.

2. CHECK FRONT LIFTING MOTOR HARNESS

1. Disconnect front lifting motor connector.
2. Check continuity between front power seat passenger side switch connector B342 terminals 10 (OR), 11 (LG) and front lifting motor connector B346 terminals 10 (OR), 11 (LG).

10 (OR) – 10 (OR) :Continuity should exist.
11 (LG) – 11 (LG) :Continuity should exist.

3. Check continuity between front power seat passenger side switch connector B342 terminals 10 (OR), 11 (LG) and ground.

10 (OR) – Ground :Continuity should not exist.
11 (LG) – Ground :Continuity should not exist.

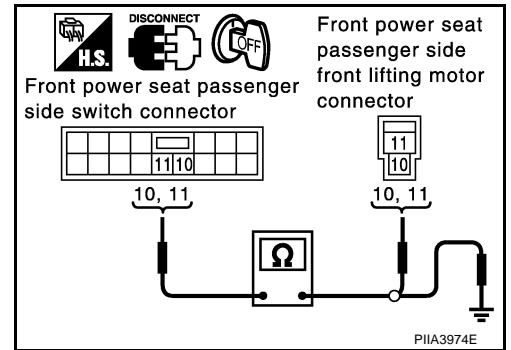

OK or NG

- OK >> Replace front lifting motor.
 NG >> Repair or replace harness between front power seat passenger side switch and front lifting motor.

POWER SEAT

Front Power Seat Passenger Side Rear Lifting Circuit Inspection

EIS008LE

1. CHECK POWER SEAT SWITCH

1. Turn ignition switch OFF.
2. Disconnect front power seat passenger side switch connector.
3. Check continuity between front power seat passenger side switch as follows.

Terminal	Condition	Continuity	
4	15A	Rear lifting switch up.	Yes
	16	Rear lifting switch down.	Yes
	15A, 16	Other than above	No
6	15A	Rear lifting switch down.	Yes
	16	Rear lifting switch up.	Yes
	15A, 16	Other than above	No

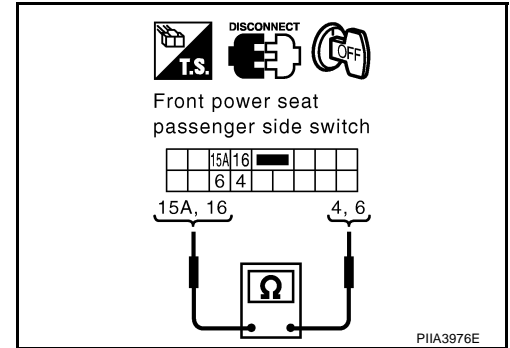

OK or NG

OK >> GO TO 2.

NG >> Replace front power seat passenger side switch.

2. CHECK REAR LIFTING MOTOR HARNESS

1. Disconnect front power seat passenger side switch connector and rear lifting motor connector.
2. Check continuity between front power seat passenger side switch connector B342 terminals 4 (R), 6 (Y) and rear lifting motor connector B347 terminals 4 (R), 6 (Y).

4 (R) – 4 (R) :Continuity should exist.

6 (Y) – 6 (Y) :Continuity should exist.

3. Check continuity between front power seat passenger side switch connector B342 terminals 4 (R), 6 (Y) and ground.

4 (R) – Ground :Continuity should not exist.

6 (Y) – Ground :Continuity should not exist.

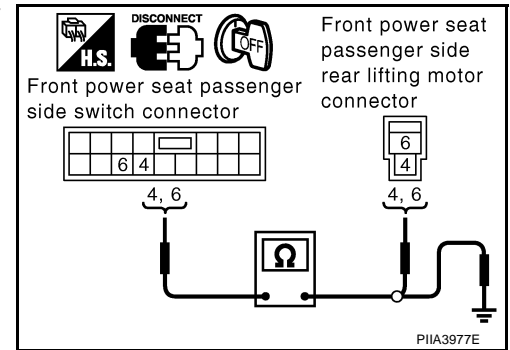

OK or NG

OK >> Replace rear lifting motor.

NG >> Repair or replace harness between front power seat passenger side switch and rear lifting motor.

Rear Power Seat Control unit Power Supply and Ground Circuit Inspection (With Heated Seat)

EIS008LF

1. CHECK REAR POWER SEAT CONTROL UNIT POWER SUPPLY CIRCUIT

1. Turn ignition switch OFF.
2. Disconnect rear power seat control unit connector.
3. Check voltage between rear power seat control unit connector B162 (LH), B362 (RH) terminal 2 (G) and ground.

2 (G) – Ground : Battery voltage.

OK or NG

OK >> GO TO 2.

NG >> Repair or replace harness between fuse block (J/B) No.1 and rear power seat control unit.

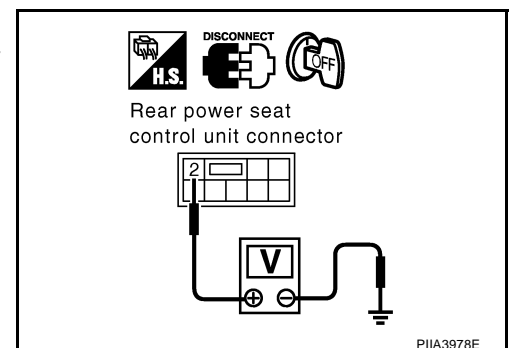

POWER SEAT

2. CHECK REAR POWER SEAT CONTROL UNIT GROUND CIRCUIT

1. Check continuity between rear power seat control unit connector B162 (LH), B362 (RH) terminals 15 (B) and ground.

15 (B) – Ground :Continuity should exist.

2. Check continuity between rear power seat control unit connector B163 (LH), B363 (RH) terminals 28 (B) and ground.

28 (B) – Ground :Continuity should exist.

OK or NG

- OK >> Rear power seat control unit power supply and ground circuit check is OK.
 NG >> Repair or replace harness between rear power seat control unit and ground.

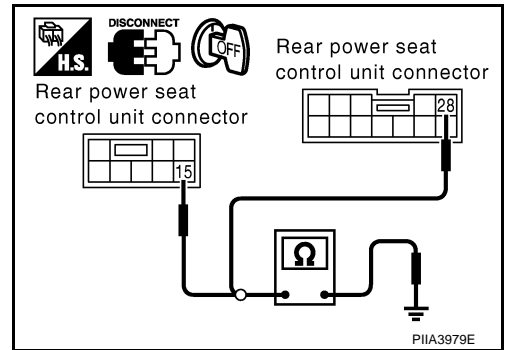

Rear Power Seat Sliding Motor Circuit Inspection (With Heated Seat)

EIS008LG

1. CHECK REAR POWER SEAT SLIDING MOTOR POWER SUPPLY

1. Turn ignition switch OFF.
2. Disconnect rear power seat sliding motor.
3. Check voltage between rear power seat control unit connector and ground.

Con- nector	Terminal (Wire color)		Condition	Voltage (V) (Approx.)
	(+)	(-)		
B162 (LH), B362 (RH)	4 (Y)	Ground	Rear power seat switch (sliding switch) forward.	Battery voltage
			Rear power seat switch (sliding switch) OFF.	0
	11 (GY)		Rear power seat switch (sliding switch) backward.	Battery voltage
			Rear power seat switch (sliding switch) OFF.	0

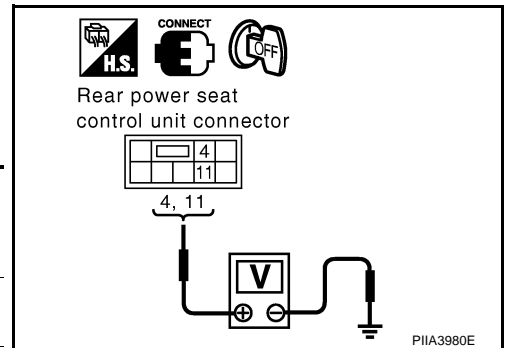

OK or NG

- OK >> Rear power seat sliding motor circuit is OK.
 NG >> GO TO 2.

POWER SEAT

2. CHECK REAR POWER SEAT SLIDING MOTOR HARNESS

1. Disconnect rear power seat control unit connector.
2. Check continuity between rear power seat control unit connector B162 (LH), B362 (RH) terminal 4 (Y), 11 (GY) and rear power seat sliding motor connector B164 (LH), B364 (RH) terminal 4 (Y), 11 (GY).

4 (Y) – 4 (Y) :Continuity should exist.

11 (GY) – 11 (GY) :Continuity should exist.

3. Check continuity between rear power seat control unit connector B162 (LH), B362 (RH) terminal 4 (Y), 11 (GY) and ground.

4 (Y) – Ground :Continuity should not exist.

11 (GY) – Ground :Continuity should not exist.

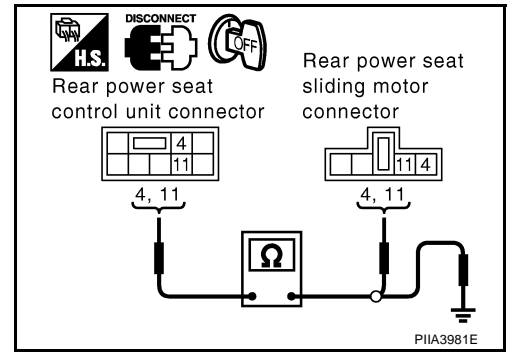

OK or NG

OK >> Replace rear power seat sliding motor.

NG >> Repair or replace harness between rear power seat control unit and rear power seat sliding motor.

Rear Power Seat Switch Circuit Inspection (With Heated Seat)

E/S008LH

1. CHECK REAR POWER SEAT SWITCH POWER SUPPLY

1. Turn ignition switch OFF.
2. Check voltage between rear power seat control unit connector and ground.

Con- nector	Terminal (Wire color)		Condition	Voltage (V) (Approx.)
	(+)	(-)		
B163 (LH) B363 (RH)	18 (BR/W)	Ground	Rear power seat switch (sliding switch) backward.	0
			Rear power seat switch (sliding switch) OFF.	Battery voltage
	24 (L/G)		Rear power seat switch (sliding switch) forward.	0
			Rear power seat switch (sliding switch) OFF.	Battery voltage

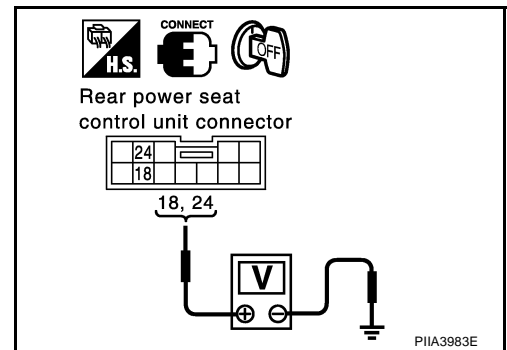

OK or NG

OK >> Rear power seat switch circuit check is OK.

NG >> GO TO 2.

POWER SEAT

2. CHECK REAR POWER SEAT SWITCH HARNESS

1. Disconnect rear power seat control unit connector and rear power seat switch connector.
2. Check continuity between rear power seat control unit connector B163 (LH), B363 (RH) terminal 18 (BR/W), 24 (L/G) and rear power seat switch connector D55 (LH), D75 (RH) terminal 7 (G/Y), 8 (OR/L).

LH

18 (BR/W) – 7 (G/Y) :Continuity should exist

24 (L/G) – 8 (OR/L) :Continuity should exist

RH

18 (BR/W) – 8 (OR/L) :Continuity should exist

24 (L/G) – 7 (G/Y) :Continuity should exist

3. Check continuity between rear power seat control unit connector B163 (LH), B363 (RH) terminal 18 (BR/W), 24 (L/G) and ground.

18 (BR/W) – Ground :Continuity should not exist

24 (L/G) – Ground :Continuity should not exist

OK or NG

OK >> GO TO 3.

NG >> Repair or replace harness between rear power seat control unit and rear power seat switch.

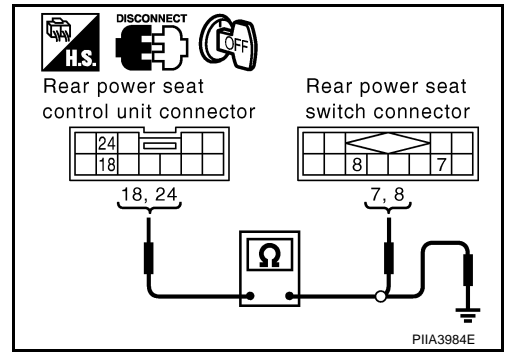

3. CHECK REAR POWER SEAT SWITCH

Check continuity between rear power seat switch as follows.

Terminal	Condition	Continuity
7	Rear power seat switch (sliding switch) backward.	Yes
	Rear power seat switch (sliding switch) OFF.	No
8	Rear power seat switch (sliding switch) forward.	Yes
	Rear power seat switch (sliding switch) OFF.	No

OK or NG

OK >> GO TO 4.

NG >> Replace rear power seat switch.

4. CHECK REAR POWER SEAT SWITCH GROUND CIRCUIT

Check continuity between rear power seat switch connector D55 (LH), D75 (RH) terminal 2 (B) and ground.

2 (B) – Ground :Continuity should exist

OK or NG

OK >> Replace rear power seat control unit.

NG >> Repair or replace harness between rear power seat switch and ground.

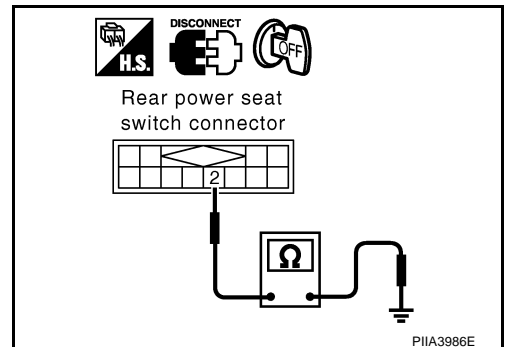
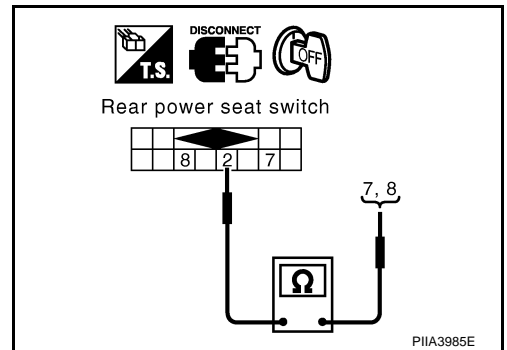

POWER SEAT

Auto Return Cancel Switch Circuit Inspection 1 (With Heated Seat)

EIS008LI

1. CHECK AUTO RETURN CANCEL SWITCH POWER SUPPLY

1. Turn ignition switch OFF.
2. Check voltage between rear power seat control unit connector and ground.

Con- nector	Terminal (Wire color)		Condition	Voltage (V) (Approx.)
	(+)	(-)		
B163 (LH), B363 (RH)	36 (LG/R)	Ground	Auto return cancel switch ON and, rear door LH open.	5
			Other than above.	0

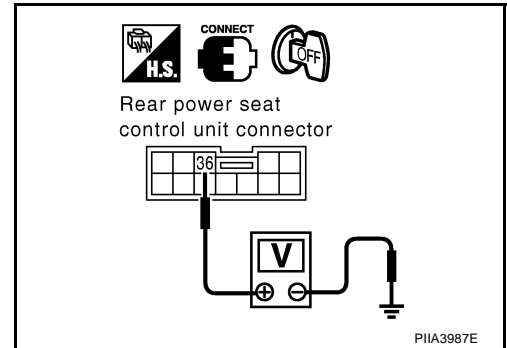

OK or NG

- OK >> Auto return cancel switch circuit check is OK.
 NG >> GO TO 2.

2. CHECK REAR POWER SEAT SWITCH HARNESS

1. Disconnect rear power seat control unit connector and auto return cancel switch connector.
2. Check continuity between rear power seat control unit connector B163 (LH), B363 (RH) terminal 36 (LG/R) and auto return cancel switch connector B504 terminal 1 (BR).

36 (LG/R) – 1 (BR) :Continuity should exist

3. Check continuity between rear power seat control unit connector B163 (LH), B363 (RH) terminal 36 (LG/R) and ground.

36 (LG/R) – Ground :Continuity should not exist

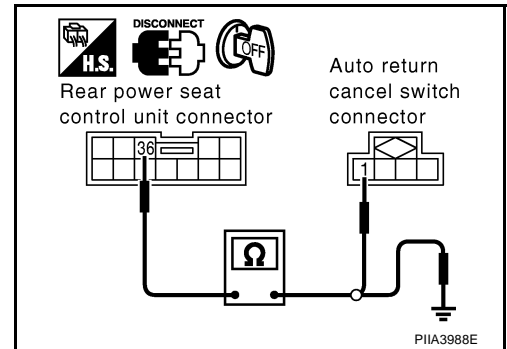

OK or NG

- OK >> Check the condition of the harness and connector.
 NG >> Repair or replace harness between rear power seat control unit and auto return cancel switch.

Auto Return Cancel Switch Circuit Inspection 2 (With Heated Seat)

EIS008LJ

1. CHECK AUTO RETURN CANCEL SWITCH HARNESS

1. Turn ignition switch OFF.
2. Disconnect rear power seat control unit connector and auto return cancel switch connector.
3. Check continuity between rear power seat control unit connector B163 (LH), B363 (RH) terminal 36 (LG/R) and auto return cancel switch connector B504 terminal 1 (BR).

36 (LG/R) – 1 (BR) :Continuity should exist

4. Check continuity between rear power seat control unit connector B163 (LH), B363 (RH) terminal 36 (LG/R) and ground.

36 (LG/R) – Ground :Continuity should not exist

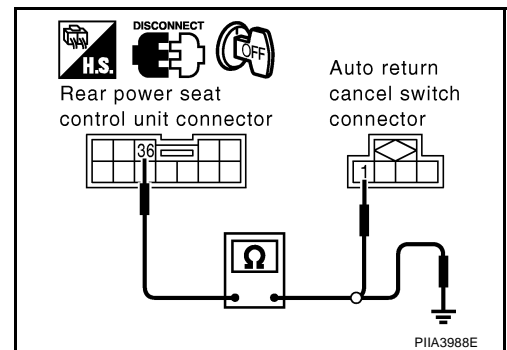

OK or NG

- OK >> GO TO 2.
 NG >> Repair or replace harness between rear power seat control unit and auto return cancel switch.

POWER SEAT

2. CHECK AUTO RETURN CANCEL SWITCH

Check continuity between auto cancel switch as follows.

Terminal		Condition	Continuity
1	2	Auto return cancel switch cancelled.	Yes
		Auto return cancel switch ON.	No

OK or NG

- OK >> GO TO 3.
- NG >> Replace auto return cancel switch.

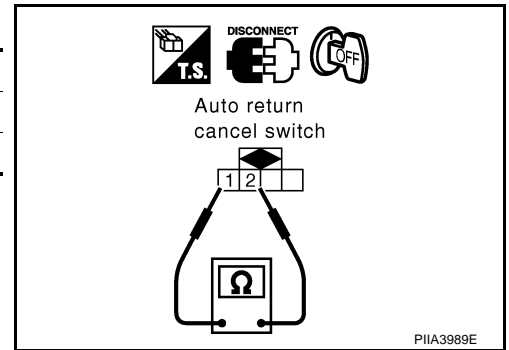

3. CHECK AUTO RETURN CANCEL SWITCH GROUND HARNESS

Check continuity between auto return cancel switch connector B504 terminal 2 (B) and ground.

2 (B) – Ground :Continuity should exist

OK or NG

- OK >> Check the harness and connector.
- NG >> Repair or replace harness between auto return cancel switch and ground.

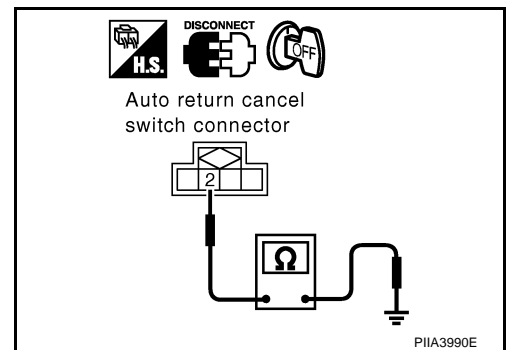

Rear Door Switch Circuit Inspection (With Heated Seat)

1. CHECK REAR DOOR SWITCH POWER SUPPLY

1. Turn ignition switch OFF.
2. Check voltage between rear power seat control unit connector and ground.

Con- nector	Terminal (Wire color)		Condition	Voltage (V) (Approx.)
	(+)	(-)		
B163 (LH), B363 (RH)	43 (GY/R)	Ground	Rear door open.	0
			Rear door closed.	Battery voltage

OK or NG

- OK >> Rear door switch circuit check is OK.
- NG >> GO TO 2.

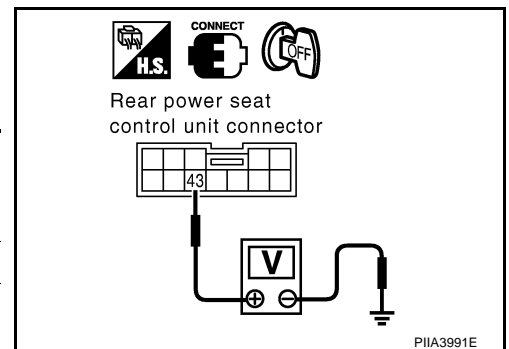

POWER SEAT

2. CHECK DOOR SWITCH HARNESS

1. Disconnect rear power seat control unit connector and door lock assembly (door switch) connector.
2. Check continuity between rear power seat control unit connector B163 (LH), B363 (RH) terminal 43 (GY/R) and door lock assembly (door switch) connector D62 (LH), D82(RH) terminal 1 (W).

43 (GY/R) – 1 (BR) :Continuity should exist

3. Check continuity between rear power seat control unit connector B163 (LH), B363 (RH) terminal 43 (GY/R) and ground.

43 (GY/R) – Ground :Continuity should not exist

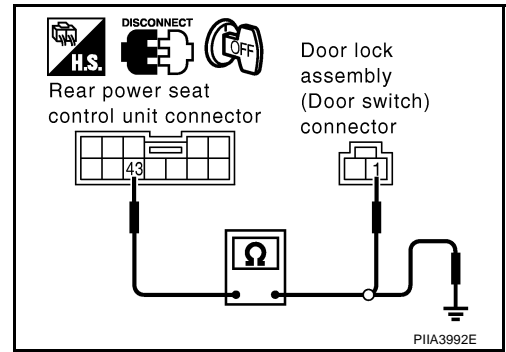

OK or NG

OK >> GO TO 3.

NG >> Repair or replace harness between rear power seat control unit and door lock assembly (door switch).

3. CHECK DOOR SWITCH

1. Disconnect door lock assembly connector.
2. Check continuity between door lock assembly as follows.

Terminal		Condition	Continuity
1	2	Door switch ON	Yes
		Door switch OFF	No

OK or NG

OK >> GO TO 4.

NG >> Replace door lock assembly.

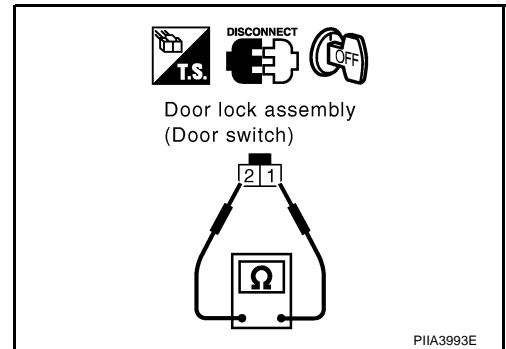

4. CHECK DOOR SWITCH HARNESS

Check continuity between door lock assembly connector D62 (LH), D82 (RH) terminal 2 (B) and ground.

2 (B) – Ground :Continuity should exist

OK or NG

OK >> Check the condition of the harness and connector.

NG >> Repair or replace harness between door lock assembly and ground.

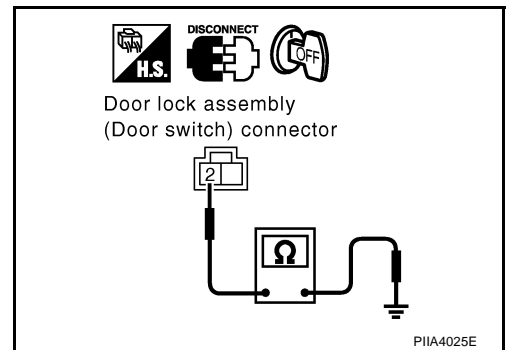

POWER SEAT

Rear Power Seat Sliding Sensor Circuit Inspection (With Heated Seat)

E/IS008LL

1. CHECK REAR POWER SEAT SLIDING MOTOR SENSOR POWER SUPPLY

1. Turn ignition switch OFF.
2. Check signal between rear power seat control unit connector and ground with oscilloscope.

Con- nec- tor	Terminal (Wire color)		Condition	Signal (Reference valve)
	(+)	(-)		
B163 (LH), B363 (RH)	21 (W/G)	Ground	Rear power seat switch (sliding switch) forward or backward.	<p style="text-align: right;">SIIA0690J</p>

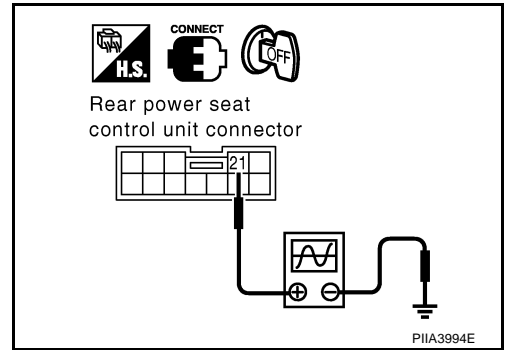

OK or NG

- OK >> Rear power seat sliding sensor circuit check is OK.
 NG >> GO TO 2.

2. CHECK REAR POWER SEAT SLIDING MOTOR SENSOR HARNESS

1. Disconnect rear power seat control unit connector and rear power seat sliding motor sensor connector.
2. Check continuity between rear power seat control unit connector B163 (LH), B363 (RH) terminal 21 (W/G), 74 (G/R) and rear power seat sliding motor connector B164 (LH), B364 (RH) terminal 21 (W/G), 74 (G/R).

21 (W/G) – 21 (W/G) :Continuity should exist.
74 (G/R) – 74 (G/R) :Continuity should exist.

3. Check continuity between rear power seat control unit connector B163 (LH), B363 (RH) terminal 21 (W/G), 74 (G/R) and ground.

21 (W/G) – Ground :Continuity should not exist.
74 (G/R) – Ground :Continuity should not exist.

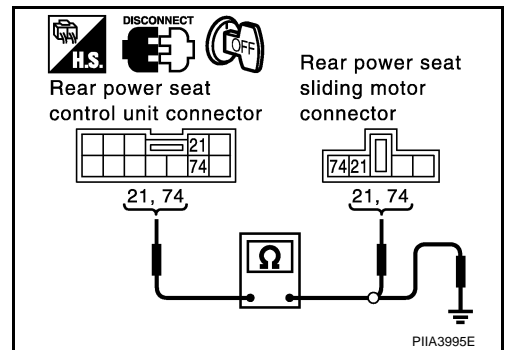

OK or NG

- OK >> Replace rear power seat sliding motor.
 NG >> Repair or replace harness between rear power seat control unit and rear power seat sliding motor.

POWER SEAT

Rear Power Seat Control Unit Power Supply and Ground Inspection (Without Heated Seat)

EIS008LM

1. CHECK REAR POWER SEAT CONTROL UNIT POWER SUPPLY CIRCUIT

1. Turn ignition switch OFF.
2. Disconnect rear power seat control unit connector.
3. Check voltage between rear power seat control unit connector B168 (LH), B368 (RH) terminal 2 (G) and ground.

2 (G) – Ground : Battery voltage

OK or NG

- OK >> GO TO 2.
 NG >> Repair or replace harness between fuse block (J/B) No.1 and rear power seat control unit.

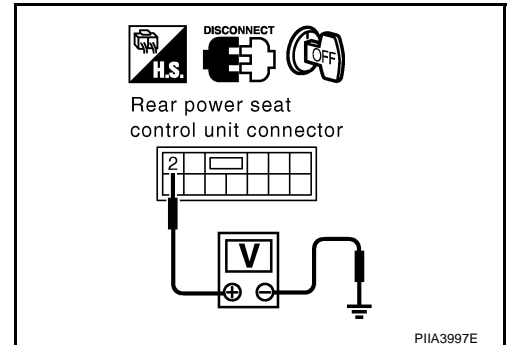

2. CHECK REAR POWER SEAT CONTROL UNIT GROUND CIRCUIT

Check continuity between rear power seat control unit connector B168 (LH), B368 (RH) terminals 15 (B), 28 (G/B) and ground.

15 (B) – Ground :Continuity should exist

28 (G/B) – Ground :Continuity should exist

OK or NG

- OK >> Rear power seat control unit power supply and ground circuit check is OK.
 NG >> Repair or replace harness between rear power seat control unit and ground.

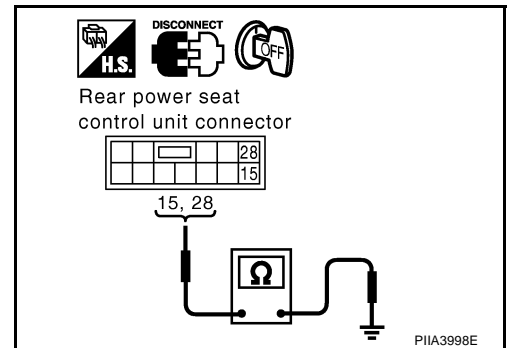

Rear Power Seat Sliding Motor Circuit Inspection (Without Heated Seat)

EIS008LN

1. CHECK REAR POWER SEAT SLIDING MOTOR POWER SUPPLY

1. Turn ignition switch OFF.
2. Check voltage between rear power seat control unit connector and ground.

Con- nector	Terminal (Wire color)		Condition	Voltage (V) (Approx.)
	(+)	(-)		
B168 (LH), B368 (RH)	4 (Y)	Ground	Rear power seat switch (sliding switch) forward.	Battery voltage
			Rear power seat switch (sliding switch) OFF.	0
	11 (GY)		Rear power seat switch (sliding switch) backward.	Battery voltage
			Rear power seat switch (sliding switch) OFF.	0

OK or NG

- OK >> Rear power seat sliding motor circuit is OK.
 NG >> GO TO 2.

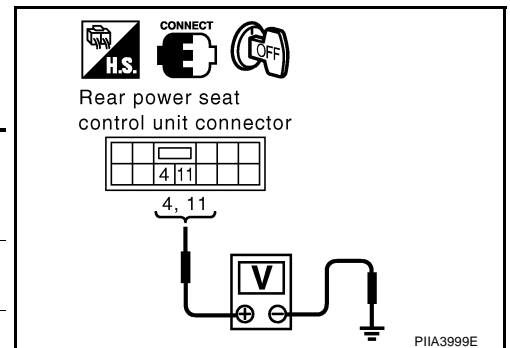

POWER SEAT

2. CHECK REAR POWER SEAT SLIDING MOTOR HARNESS

1. Disconnect rear power seat control unit connector and rear power seat sliding motor connector.
2. Check continuity between rear power seat control unit connector B168 (LH), B368 (RH) terminal 4 (Y), 11 (GY) and rear power seat sliding motor connector B164 (LH), B364 (RH) terminal 4 (Y), 11 (GY).

4 (Y) – 4 (Y) :Continuity should exist
11 (GY) – 11 (GY) :Continuity should exist

3. Check continuity between rear power seat control unit connector B168 (LH), B368 (RH) terminal 4 (Y), 11 (GY) and ground.

4 (Y) – Ground :Continuity should not exist
11 (GY) – Ground :Continuity should not exist

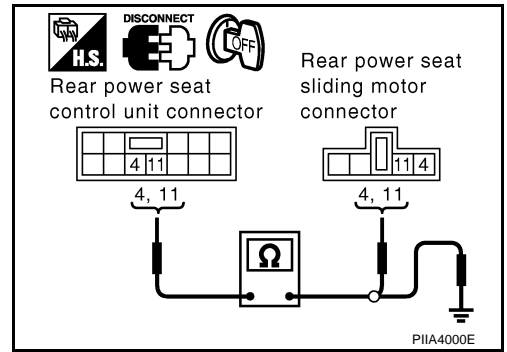

OK or NG

- OK >> Replace rear power seat sliding motor.
 NG >> Repair or replace harness between rear power seat control unit and rear power seat sliding motor.

Rear Power Seat Switch Circuit Inspection (Without Heated Seat)

E/S008L0

1. CHECK REAR POWER SEAT SWITCH POWER SUPPLY

1. Turn ignition switch OFF.
2. Check voltage between rear power seat control unit connector and ground.

Con- nector	Terminal (Wire color)		Condition	Voltage (V) (Approx.)
	(+)	(-)		
B168 (LH), B368 (RH)	18 (BR/W)	Ground	Rear power seat switch (sliding switch) backward.	0
			Rear power seat switch (sliding switch) OFF.	Battery voltage
	24 (L/G)		Rear power seat switch (sliding switch) forward.	0
			Rear power seat switch (sliding switch) OFF.	Battery voltage

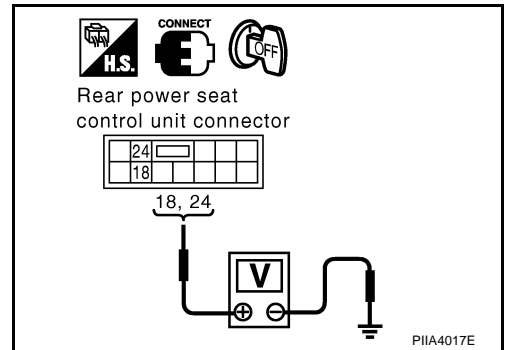

OK or NG

- OK >> Rear power seat switch circuit is OK.
 NG >> GO TO 2.

POWER SEAT

2. CHECK REAR POWER SEAT SWITCH HARNESS

1. Disconnect rear power seat control unit connector and rear power seat switch connector.
2. Check continuity between rear power seat control unit connector B168 (LH), B368 (RH) terminal 18 (BR/W), 24 (L/G) and rear power seat switch connector D55 (LH), D75 (RH) terminal 7 (G/Y), 8 (OR/L).

Rear power seat LH
18 (BR/W) – 7 (G/Y) :Continuity should exist
24 (L/G) – 8 (OR/L) :Continuity should exist

Rear power seat RH
18 (BR/W) – 8 (OR/L) :Continuity should exist
24 (L/G) – 7 (G/Y) :Continuity should exist

3. Check continuity between rear power seat control unit connector B168 (LH), B368 (RH) terminal 18 (BR/W), 24 (L/G) and ground.

18 (BR/W) – Ground :Continuity should not exist
24 (L/G) – Ground :Continuity should not exist

OK or NG

OK >> GO TO 3.

NG >> Repair or replace harness between rear power seat control unit and rear power seat switch.

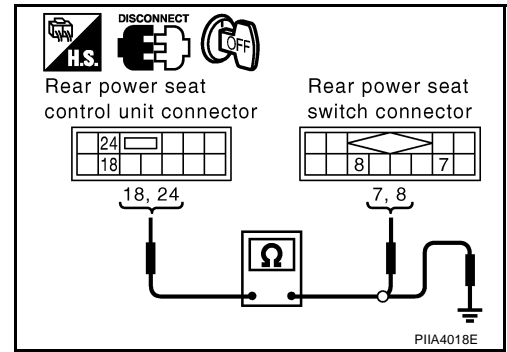

3. CHECK REAR POWER SEAT SWITCH

Check continuity between rear power seat switch as follows.

Terminal	Condition	Continuity
7	Rear power seat switch (sliding switch) backward.	Yes
	Rear power seat switch (sliding switch) OFF.	No
8	Rear power seat switch (sliding switch) forward.	Yes
	Rear power seat switch (sliding switch) OFF.	No

OK or NG

OK >> GO TO 4.

NG >> Replace rear power seat switch.

4. CHECK REAR POWER SEAT SWITCH GROUND CIRCUIT

Check continuity between rear power seat switch connector D55 (LH), D75 (RH) terminal 2 (B) and ground.

2 (B) – Ground :Continuity should exist

OK or NG

OK >> Replace rear power seat control unit.

NG >> Repair or replace harness between rear power seat switch and ground.

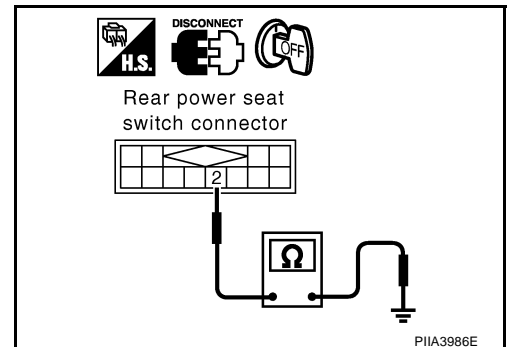
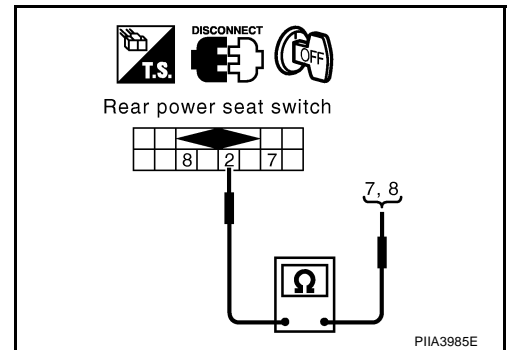

POWER SEAT

Auto Return Cancel Switch Circuit Inspection 1 (Without Heated Seat)

E/S008LP

1. CHECK AUTO RETURN CANCEL SWITCH POWER SUPPLY

1. Turn ignition switch OFF.
2. Check voltage between rear power seat control unit connector and ground.

Con- nector	Terminal (Wire color)		Condition	Voltage (V) (Approx.)
	(+)	(-)		
B168 (LH) B368 (RH)	36 (LG/R)	Ground	Auto return cancel switch ON rear door open.	5
			Other than above.	0

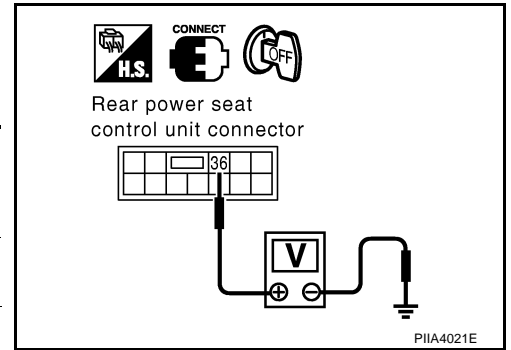

OK or NG

- OK >> INSPECTION END.
 NG >> Replace rear power seat control unit.

2. CHECK AUTO CANCEL SWITCH HARNESS

1. Disconnect rear power seat control unit connector and auto return cancel switch connector.
2. Check continuity between rear power seat control unit connector B168 (LH), B368 (RH) terminal 36 (LG/R) and auto return cancel switch connector B504 terminal 1 (BR).

36 (LG/R) – 1 (BR) :Continuity should exist

3. Check continuity between rear power seat control unit connector B168 (LH), B368 (RH) terminal 36 (LG/R) and ground.

36 (LG/R) – Ground :Continuity should not exist

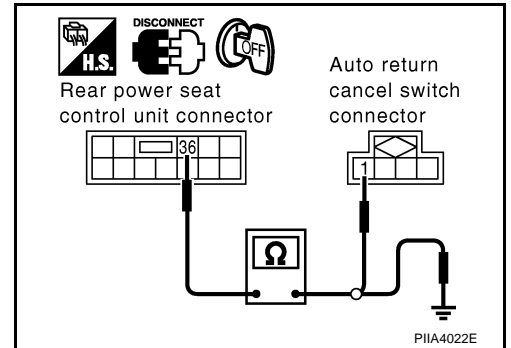

OK or NG

- OK >> Check the harness and connector.
 NG >> Repair or replace harness between rear power seat control unit and auto return cancel switch.

Auto Return Cancel Switch Circuit Inspection 2 (Without Heated Seat)

E/S008LQ

1. CHECK REAR AUTO RETURN CANCEL SWITCH HARNESS

1. Turn ignition switch OFF.
2. Disconnect rear power seat control unit connector and auto return cancel switch connector.
3. Check continuity between rear power seat control unit connector B168 (LH), B368 (RH) terminal 36 (LG/R) and auto return cancel switch connector B504 terminal 1 (BR).

36 (LG/R) – 1 (BR) :Continuity should exist

4. Check continuity between rear power seat control unit connector B168 (LH), B368 (RH) terminal 36 (LG/R) and ground.

36 (LG/R) – Ground :Continuity should not exist

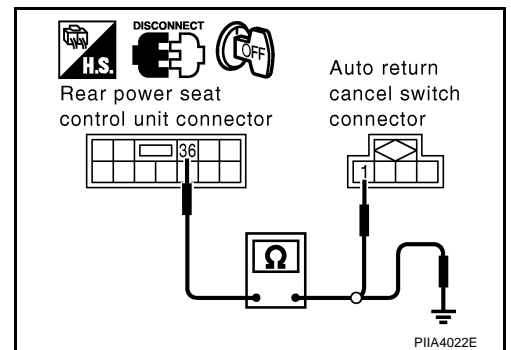

OK or NG

- OK >> GO TO 2.
 NG >> Repair or replace harness between rear power seat control unit and auto return cancel switch.

POWER SEAT

2. CHECK AUTO RETURN CANCEL SWITCH

Check continuity between auto cancel switch as follows.

Terminal		Condition	Continuity
1	2	Auto return cancel switch cancelled.	YES
		Auto return cancel switch ON.	NO

OK or NG

- OK >> GO TO 3.
- NG >> Replace auto return cancel switch.

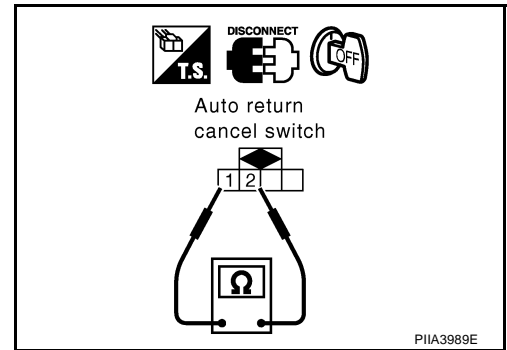

3. CHECK AUTO RETURN CANCEL SWITCH GROUND HARNESS

Check continuity between auto return cancel switch connector B504 terminal 2 (B) and ground.

2 (B) – Ground :Continuity should exist

OK or NG

- OK >> Check the harness and connector.
- NG >> Repair or replace harness between auto return cancel switch and ground.

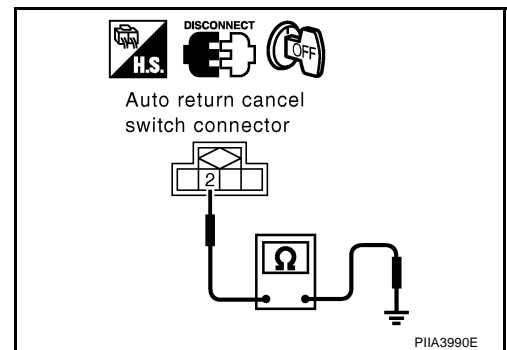

Rear Door Switch Circuit Inspection (Without Heated Seat)

EIS008LR

1. CHECK REAR DOOR SWITCH POWER SUPPLY

1. Turn ignition switch OFF.
2. Check voltage between rear power seat control unit connector and ground.

Con- nector	Terminal (Wire color)		Condition	Voltage (V) (Approx.)
	(+)	(-)		
B168 (LH), B368 (RH)	43 (GY/R)	Ground	rear door (LH) open.	0
			rear door (LH) closed.	Battery voltage

OK or NG

- OK >> Replace door switch circuit check is OK.
- NG >> GO TO 2.

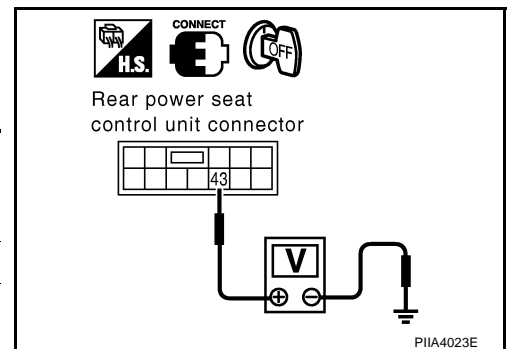

POWER SEAT

2. CHECK REAR POWER SEAT SWITCH HARNESS

1. Disconnect rear power seat control unit connector and door lock assembly (door switch) connector.
2. Check continuity between rear power seat control unit connector B168 (LH), B368 (RH) terminal 43 (GY/R) and door lock assembly (door switch) connector D62 (LH), D82(RH) terminal 1 (W).

43 (GY/R) – 1 (W) :Continuity should exist

3. Check continuity between rear power seat control unit connector B163 (LH), B363 (RH) terminal 43 (GY/R) and ground.

43 (GY/R) – Ground :Continuity should not exist

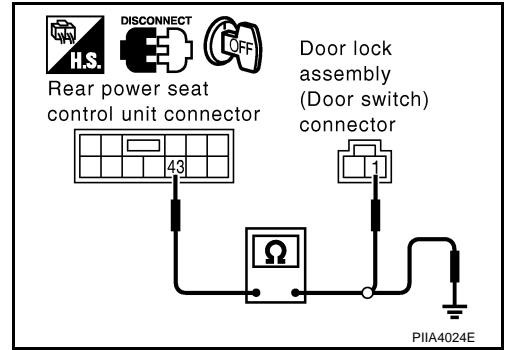

OK or NG

OK >> GO TO 3.

NG >> Repair or replace harness between rear power seat control unit and door lock assembly (door switch).

3. CHECK CANCEL SWITCH

Check continuity between door lock assembly connector.

Terminal		Condition	Continuity
1	2	Door switch ON.	YES
		Door switch OFF.	NO

OK or NG

OK >> GO TO 4.

NG >> Replace door lock assembly.

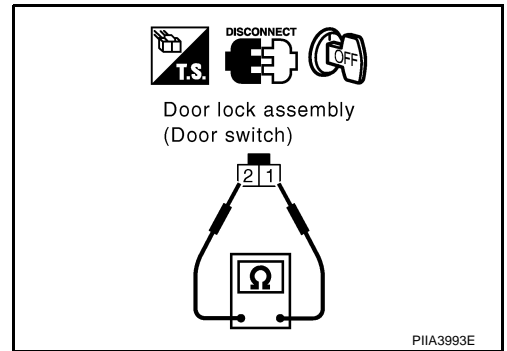

4. CHECK REAR POWER SEAT SWITCH HARNESS

Check continuity between door lock assembly connector D62 (LH), D82 (RH) terminal 2 (B) and ground.

2 (B) – Ground :Continuity should exist

OK or NG

OK >> Check the condition of the harness and connector.

NG >> Repair or replace harness between door lock assembly and ground.

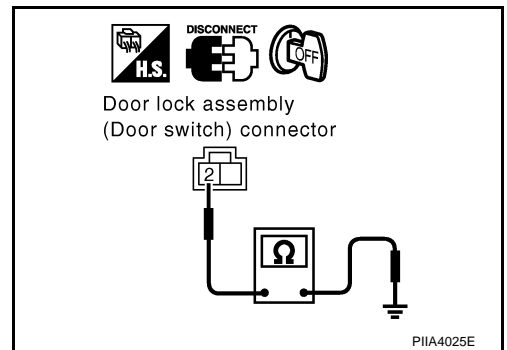

POWER SEAT

Rear Power Seat Sliding Sensor Circuit Inspection (Without Heated Seat)

E/S008LS

1. CHECK REAR POWER SEAT SLIDING MOTOR SENSOR POWER SUPPLY

1. Turn ignition switch OFF.
2. Check signal between rear power seat control unit connector and ground with oscilloscope.

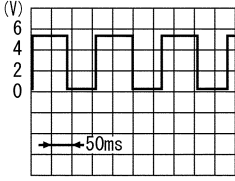
Con- nec- tor	Terminal (Wire color)		Condition	Signal (Reference valve)
	(+)	(-)		
B168 (LH), B368 (RH)	21 (W/G)	Ground	Rear power seat switch (sliding switch) forward or backward.	 <p style="text-align: right;">SIIA0690J</p>

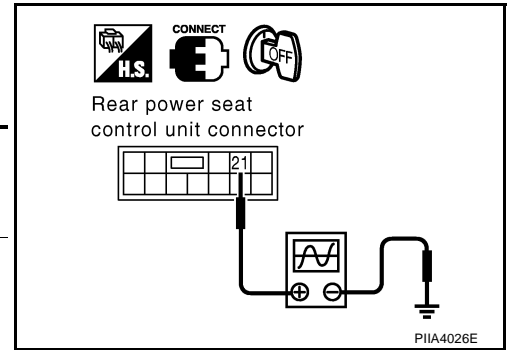

OK or NG

- OK >> Rear power seat sliding motor sensor circuit check is OK.
 NG >> GO TO 2.

2. CHECK REAR POWER SEAT SLIDING MOTOR SENSOR HARNESS

1. Disconnect rear power seat control unit connector and rear power seat sliding motor sensor connector.
2. Check continuity between rear power seat control unit connector B168 (LH), B368 (RH) terminal 21 (W/G), 74 (G/R) and rear power seat sliding motor connector B164 (LH), B364 (RH) terminal 21 (W/G), 74 (G/R).

21 (W/G) – 21 (W/G) :Continuity should exist
74 (G/R) – 74 (G/R) :Continuity should exist

3. Check continuity between rear power seat control unit connector B168 (LH), B368 (RH) terminal 21 (W/G), 74 (G/R) and ground.

21 (W/G) – Ground :Continuity should not exist
74 (G/R) – Ground :Continuity should not exist

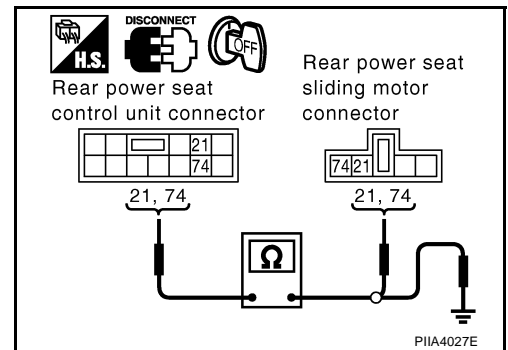

OK or NG

- OK >> Replace rear power seat sliding motor.
 NG >> Repair or replace harness between rear power seat control unit and rear power seat sliding motor.

HEATED SEAT

System Description

EIS008LT

NOTE:

- When handling seat, be extremely careful not to scratch heating unit
- To replace heating unit, seat trim and pad should be separated.
- Do not use any organic solvent, such as thinner, benzene, alcohol, etc. to clean trims.

B

Power is all times supplied

- through 40A fusible link [Letter H, located in the fuse block (J/B)],
- to rear power seat control unit LH and rear power seat control unit RH terminal 2.

C

With the ignition switch to ON or START position, power is supplied

- through 20A fuse [No. 81, located in the fuse block (J/B)]
- to front heated seat switch (driver side, passenger side) terminal 1, and
- to rear power seat control unit LH, RH terminal 44,
- to rear power seat switch (heater switch) terminal 1

D

E

FRONT HEATED SEAT

When front heated seat switch (driver side, passenger side) is LOW position, power is supplied

- through heated seat switch terminal 2,
- through front seatback heater terminal 62,
- through front seatback heater terminal C,
- to front seat cushion heater terminal C.

F

G

Then ground is supplied

- to front seat cushion heater terminal 15C,
- through body grounds B17 and B57(driver side), B217 and B256 (passenger side).

H

With power and ground supplied front seatback heater and front seat cushion heater. are operated.

When front heated seat switch driver side, passenger side is HIGH position, power is supplied

- through front heated seat switch terminal 3,
- through front seatback heater terminal 63,
- through front seatback heater terminal C,
- to front seat cushion heater terminal C

J

Then ground is supplied

- to front seat cushion heater terminal 15C,
- through body grounds B17 and B57(driver side), B217 and B256 (passenger side).
- to front seatback heater terminal 62,
- through heated seat switch terminal 2,
- through heated seat switch terminal 4,
- through body grounds M25 and M115.

K

L

M

With power and ground supplied, front heated seat generates heat more than the time of LOW position.

When heated seat switch (driver side, passenger side) is LOW or HIGH position, ground is supplied

- through heated seat switch terminal 4,
- through body grounds M25 and M115.

With power and ground supplied, front heated seat switch indicator is illuminated.

REAR HEATED SEAT

When rear heater seat switch (LH, RH) is LOW position, ground is supplied

- to rear power seat control unit terminal 32,
- through rear power seat switch (heater switch) terminal 5 (LH), 6 (RH),
- through rear power seat switch (heater switch) terminal 2,
- through body grounds B17 and B57 (LH), B217 and B256 (RH)

Then rear power seat control unit recognizes that heater switch is LOW position.

HEATED SEAT

When heater seat switch is LOW position, power is supplied

- through rear power seat control unit terminal 8,
- through rear seatback heater terminal 8,
- through rear seatback heater terminal A,
- to rear seat cushion heater terminal A.

Then ground is supplied

- to rear seat cushion heater terminal 15B.
- through body grounds B17 and B57 (LH), B217 and B256 (RH).

With power and ground supplied, rear seatback heater and front seat cushion heater is.

When heater seat switch is in LOW position, ground is supplied

- to power seat switch (heater switch) terminal 3 (LH), 4 (RH),
- through rear power seat control unit terminal 26,
- through rear power seat control unit terminal 15,
- through body grounds B17 and B57 (LH), B217 and B256 (RH).

With power and ground supplied, rear heated seat switch LOW position indicator. is illuminated

When rear heater seat switch (LH, RH) is in HIGH position, ground is supplied

- to rear power seat control unit terminal 22,
- through rear power seat switch (heater switch) terminal 6 (LH), 5 (RH),
- through rear power seat switch (heater switch) terminal 2,
- through body grounds B17 and B57 (LH), B217 and B256 (RH)

Then rear power seat control unit recognizes that heater switch is in HIGH position.

When heater seat switch is in HIGH position, power is supplied

- through rear power seat control unit terminal 5,
- through rear seatback heater terminal 5,
- through rear seatback heater terminal A,
- to rear seat cushion heater terminal A.

Then ground is supplied

- to rear seat cushion heater terminal 15B.
- through body grounds B17 and B57 (LH), B217 and B256 (RH).
- to rear seat back heater terminal 8,
- through rear power seat control unit terminal 8,
- through rear power seat control unit terminal 15,
- through body grounds B17 and B57 (LH), B217 and B256 (RH).

With power and ground supplied, rear heated seat generates heat more than the time of LOW position.

When heater seat switch is in HIGH position, ground is supplied

- to power seat switch (heater switch) terminal 4 (LH), 3 (RH),
- through rear power seat control unit terminal 20,
- through rear power seat control unit terminal 15,
- through body grounds B17 and B57 (LH), B217 and B256 (RH).

With power and ground supplied rear heated seat switch HIGH position indicator is illuminated.

HEATED SEAT

Component Parts and Harness Connector Location

EIS008LU

A
B
C
D
E
F
G
H
SE
J
K
L
M

Fuse, fusible link and relay box

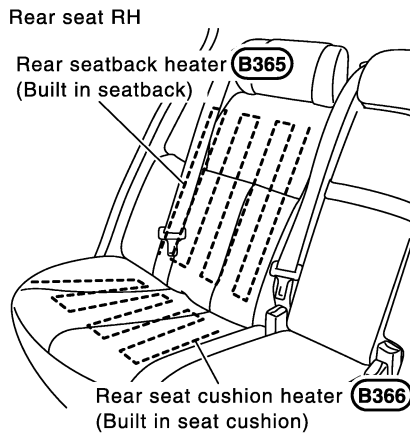
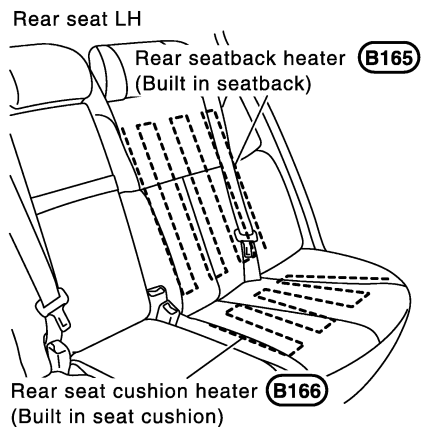
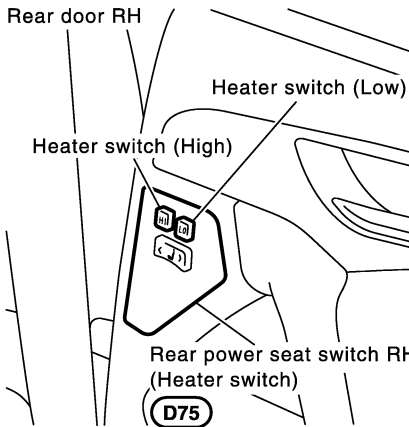
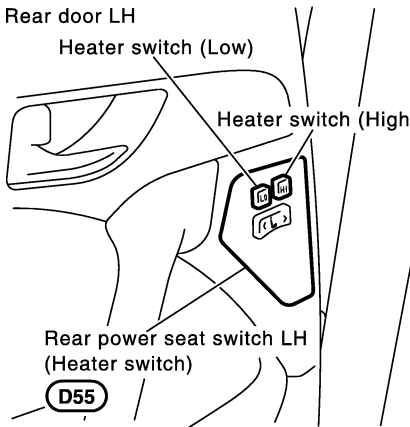
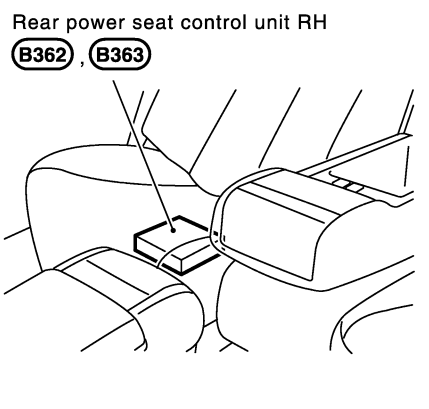
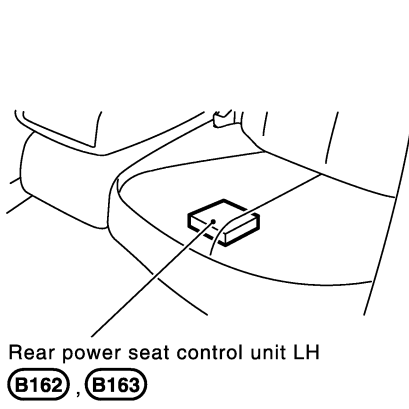
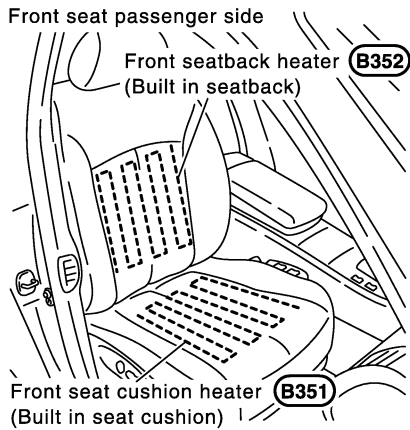
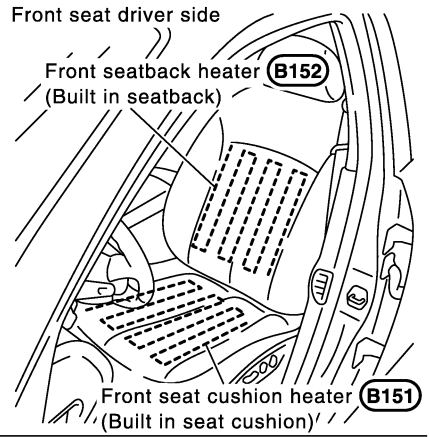
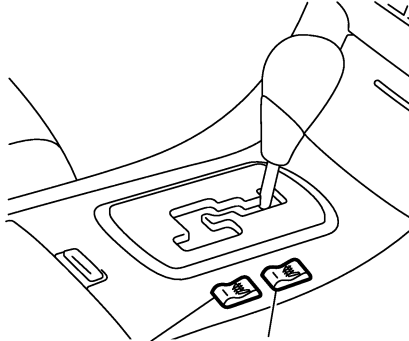
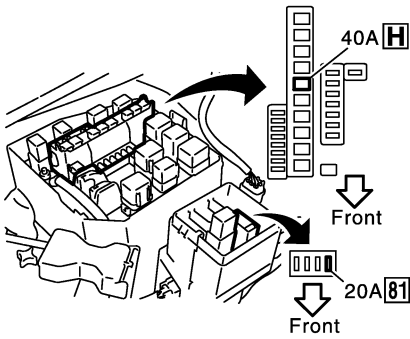

PIIA3390E

HEATED SEAT

E/S008LV

Wiring Diagram—HSEAT— FRONT HEATED SEAT

SE-HSEAT-01

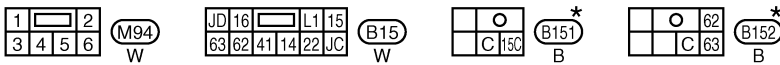
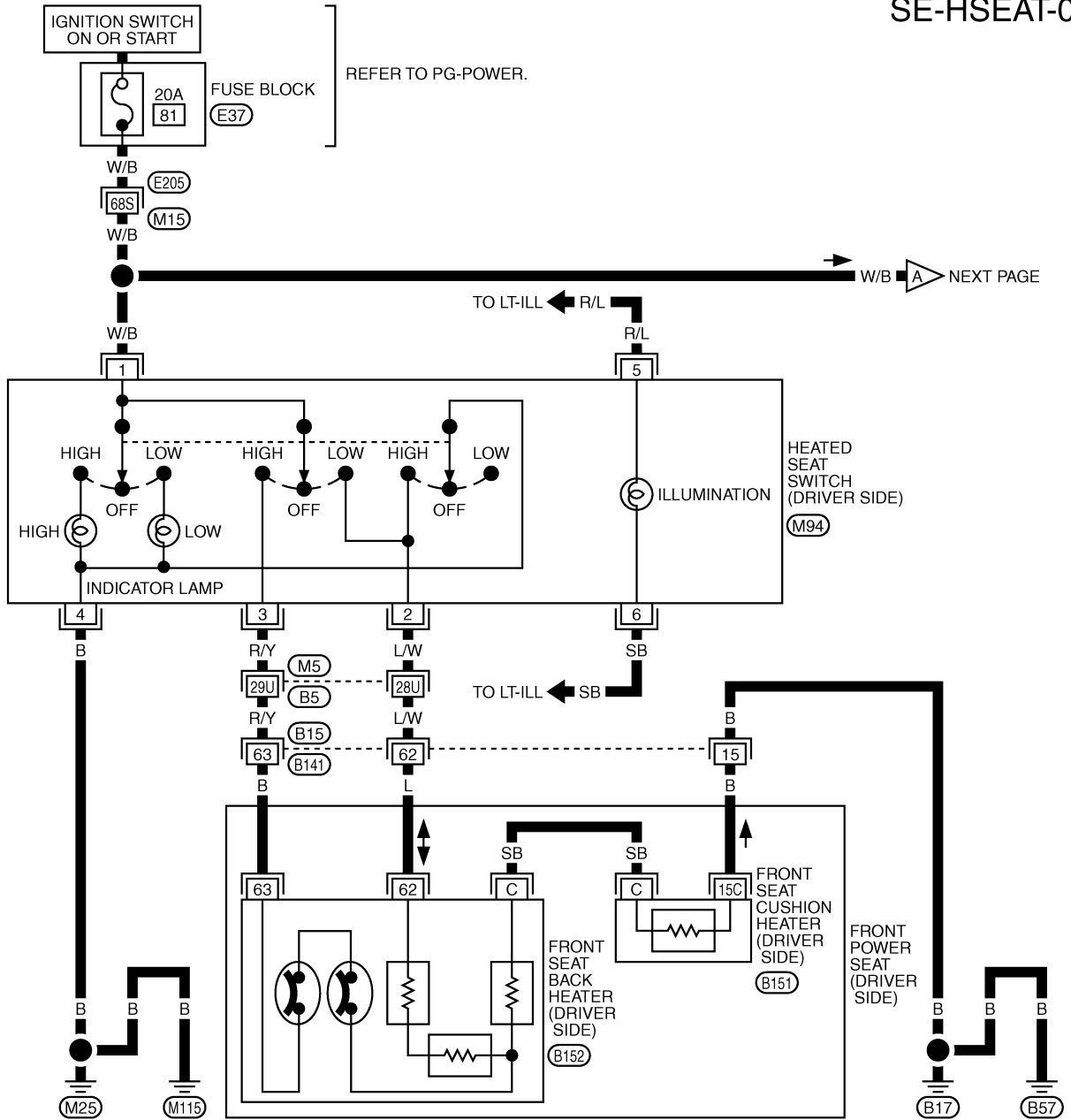

*: THIS CONNECTOR IS NOT SHOWN IN "HARNESS LAYOUT", PG SECTION.

REFER TO THE FOLLOWING.
 (M5), (E205) -SUPER MULTIPLE JUNCTION (SMJ)
 (E37) -FUSE BLOCK

TIWM0740E

HEATED SEAT

Schematic REAR HEATED SEAT

EIS008LW

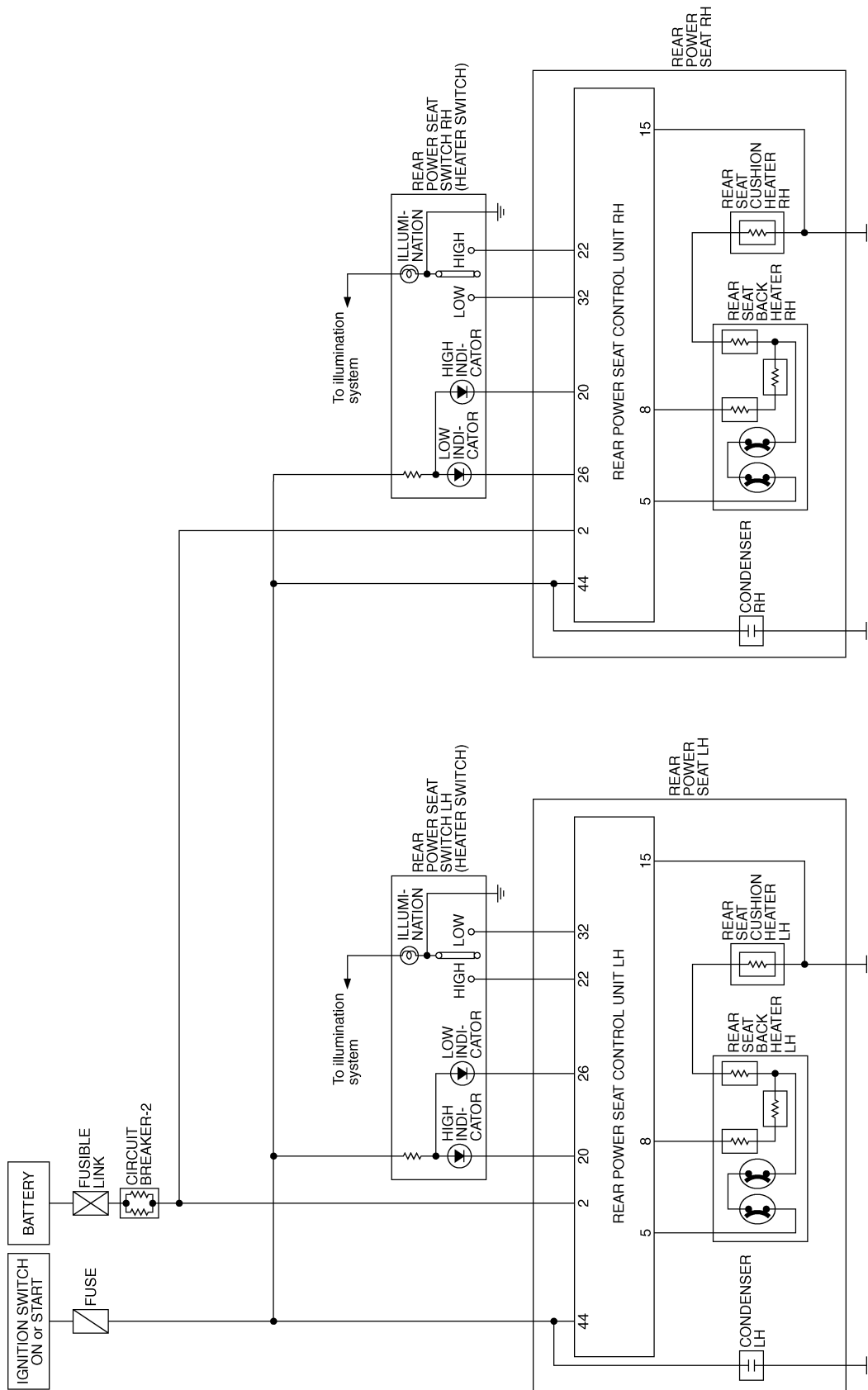

TIWM0130E

HEATED SEAT

E/S00BLX

Wiring Diagram —HSEAT— REAR HEATED SEAT

SE-HSEAT-03

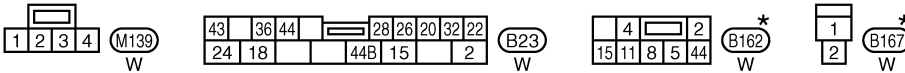
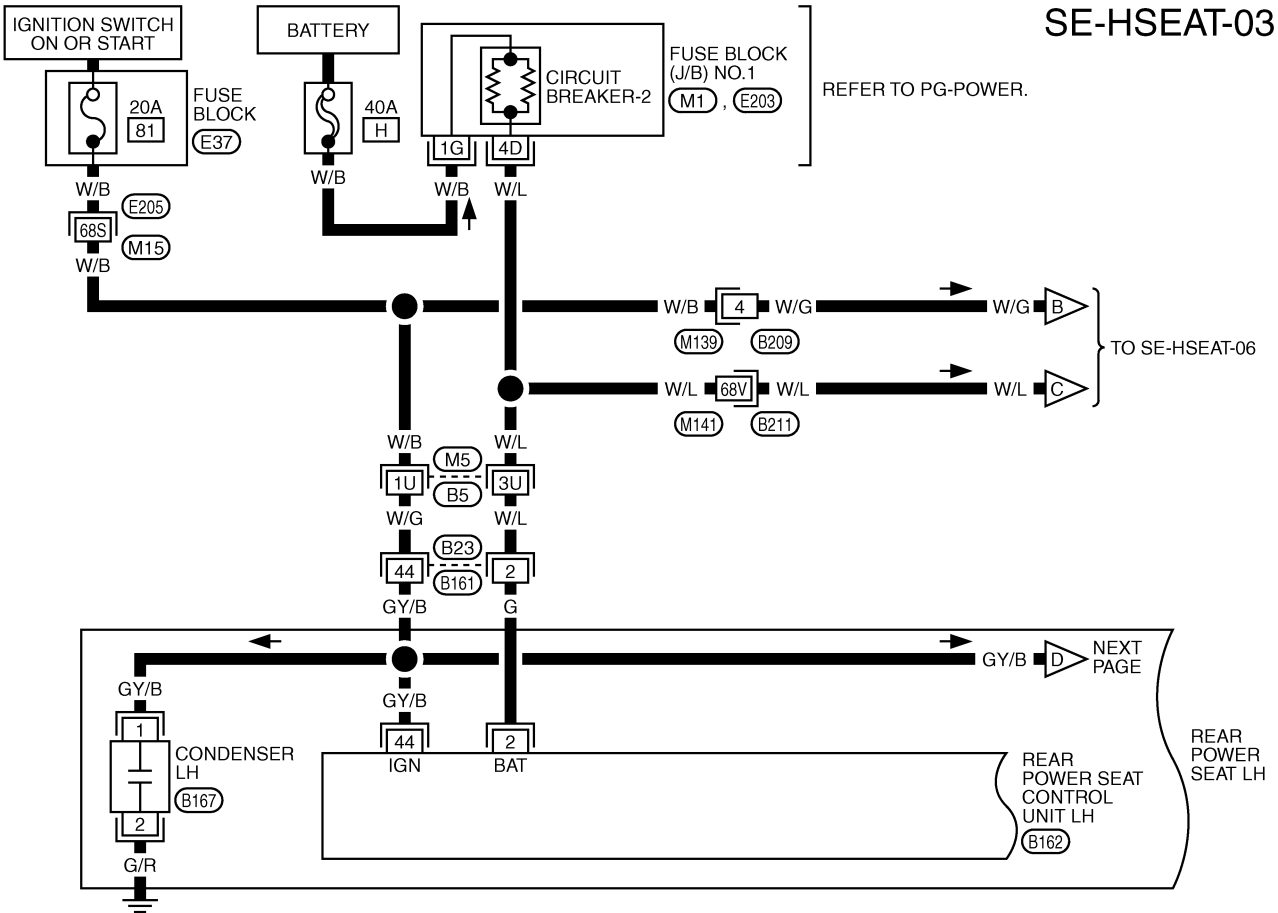

*: THIS CONNECTOR IS NOT SHOWN IN "HARNESS LAYOUT", PG SECTION.

REFER TO THE FOLLOWING.

(M5), (E205), (B211) -SUPER MULTIPLE JUNCTION (SMJ)

(M1), (E203) -FUSE BLOCK-JUNCTION BOX (J/B) NO.1

(E37) -FUSE BLOCK

T1WM0742E

HEATED SEAT

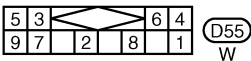
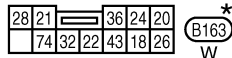
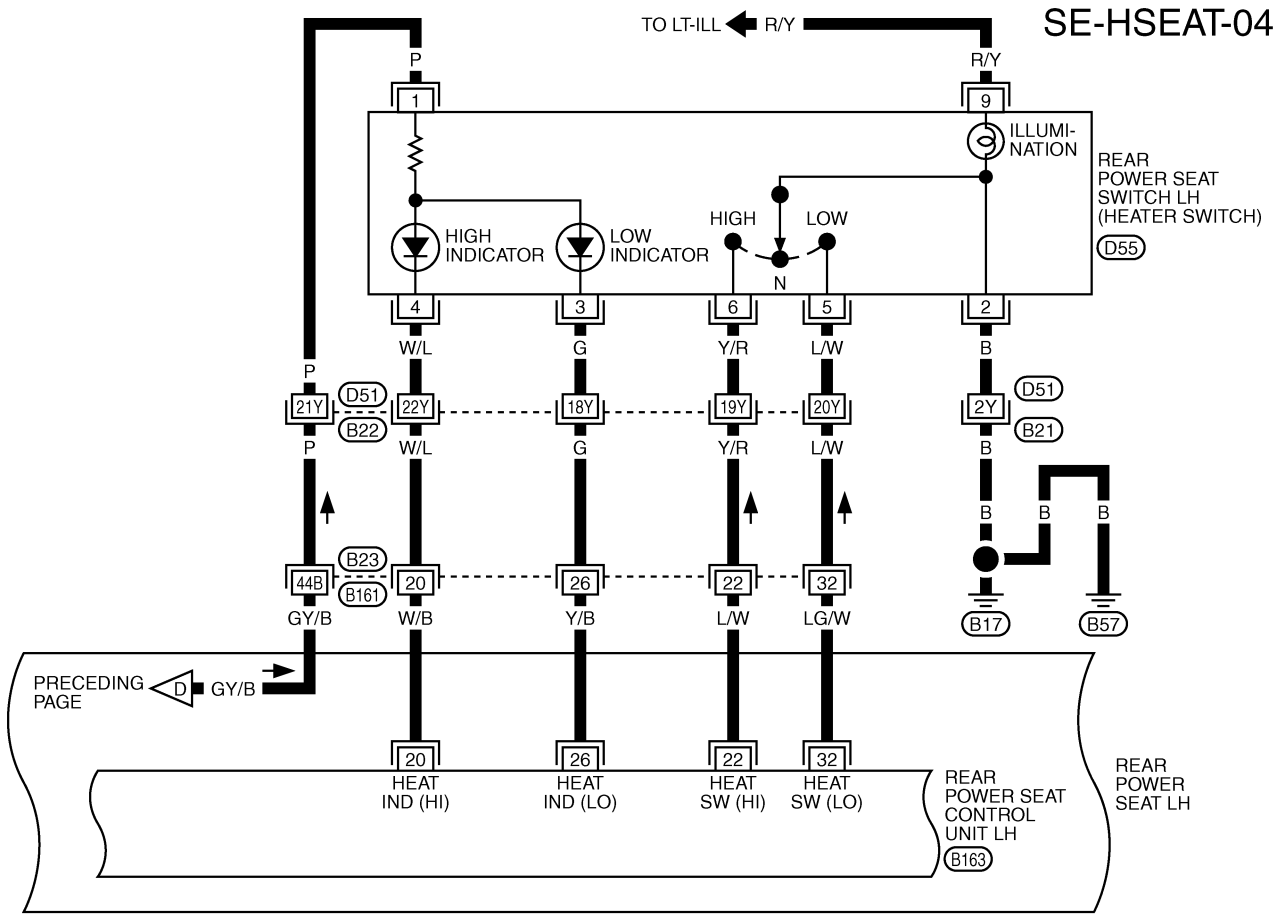

REFER TO THE FOLLOWING.
 (B21), (B22) -SUPER MULTIPLE JUNCTION (SMJ)

*: THIS CONNECTOR IS NOT SHOWN IN "HARNESS LAYOUT", PG SECTION.

TIWM0743E

HEATED SEAT

SE-HSEAT-05

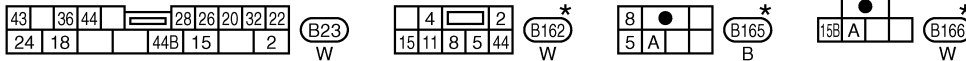
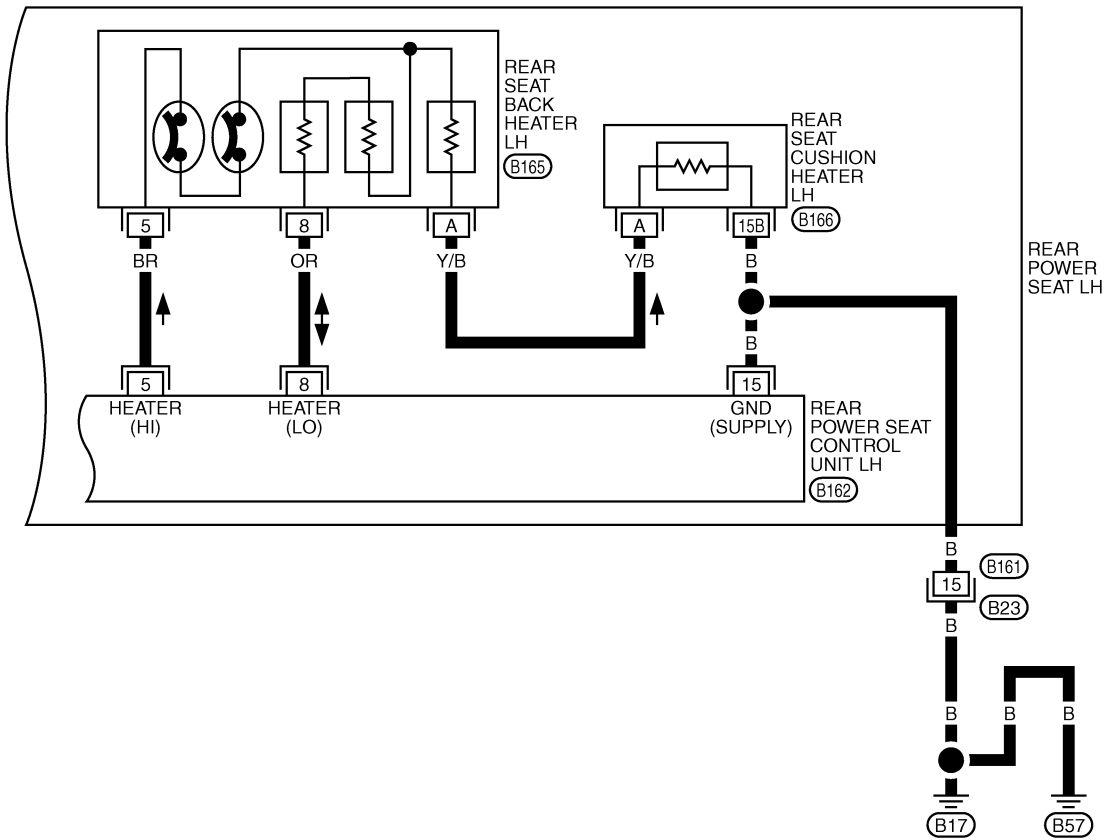

*: THIS CONNECTOR IS NOT SHOWN IN "HARNESS LAYOUT", PG SECTION.

TIVM0744E

HEATED SEAT

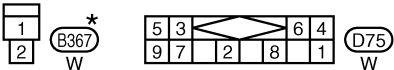
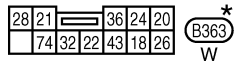
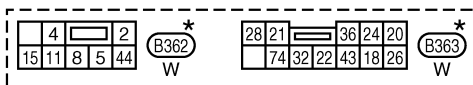
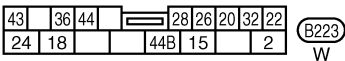
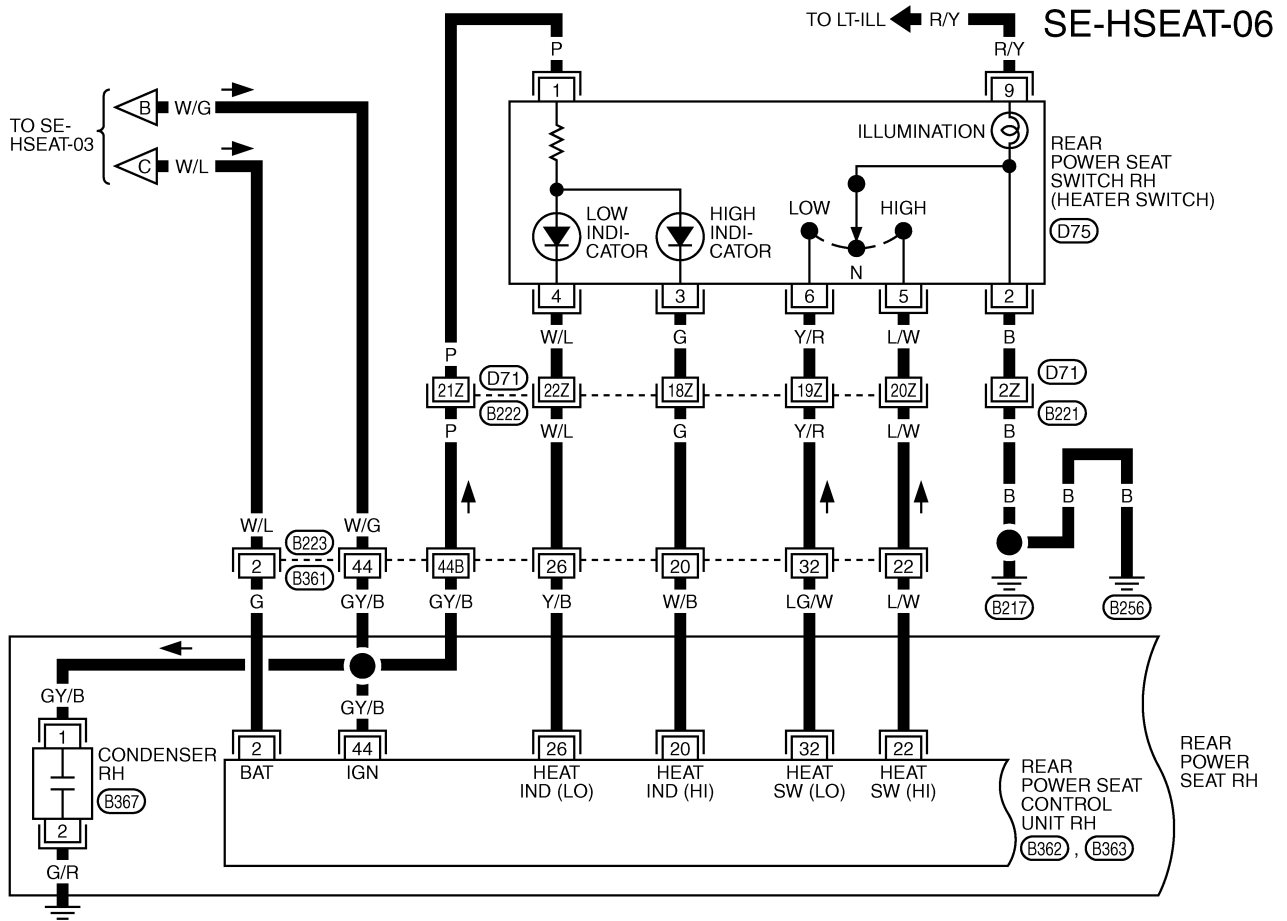

*: THIS CONNECTOR IS NOT SHOWN IN "HARNES LAYOUT", PG SECTION.

REFER TO THE FOLLOWING.
 (B221), (B222) -SUPER MULTIPLE JUNCTION (SMJ)

TIWM0745E

HEATED SEAT

SE-HSEAT-07

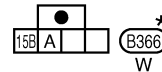
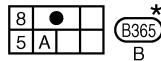
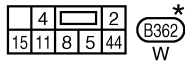
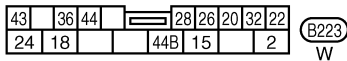
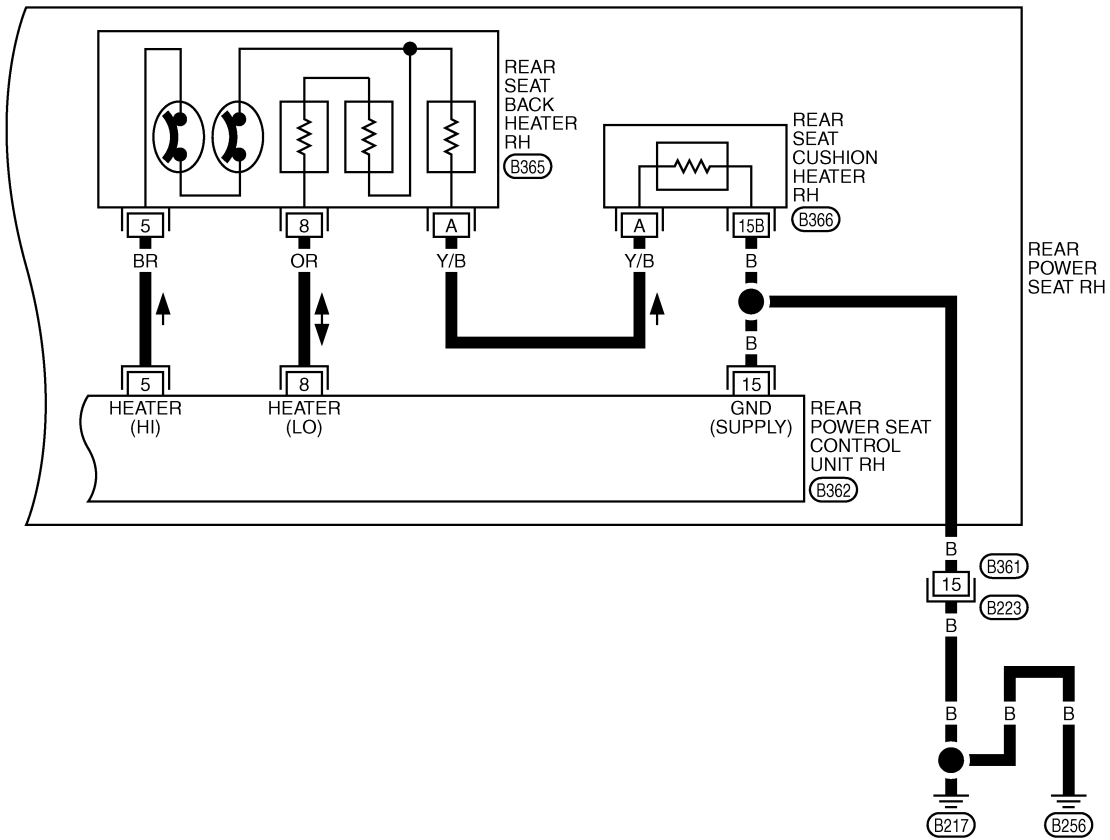

*: THIS CONNECTOR IS NOT SHOWN IN "HARNESS LAYOUT", PG SECTION.

TIVM0746E

HEATED SEAT

Terminals and Reference Values for Rear Power Seat Control Unit LH and RH

EIS008LY

TER-MINAL	WIRE COLOR	ITEM	Ignition switch	CONDITION	Voltage (V) (Approx.)
2	G	Power source (Fusible link)	ON	—	Battery voltage
5	BR	Heater Hi signal		Heater Hi operation	Battery voltage
				Other than above	0
8	OR	Heater Lo signal		Heater Lo operation	Battery voltage
				—	0
				Other than above	0
15	B	Ground		—	0
20	W/B	Heater indicator Hi signal		Heater Hi operation (lit)	1
				Other than above	Battery voltage
22	L/W	Heater switch—Hi signal		Heater switch (Hi) —ON (pressed)	0
				Heater switch (Hi)—OFF	5
				Heater Lo operation (lit)	1
26	Y/B	Heater indicator Lo signal		Other than above	Battery voltage
				Heater switch (Lo)—ON (pressed)	0
32	LG/W	Heater switch—Lo signal		Heater switch (Lo)—OFF	Battery voltage
				—	Battery voltage
44	GY/B	IGN power supply	—	Battery voltage	

Work Flow

EIS008LZ

1. Check the symptom and customer's requests.
2. Understand the outline of system. Refer to [SE-127, "System Description"](#) .
3. According to the trouble diagnosis chart, repair or replace the cause of the malfunction. Refer to [SE-139, "Trouble Diagnoses Symptom Chart"](#) .
4. Does heated seat operate normally? YES: GO TO 5, NO: GO TO 3.
5. INSPECTION END.

HEATED SEAT

Trouble Diagnoses Symptom Chart

EIS008M0

- Check that other systems using the signal of the following systems operate normally.

Symptom	Diagnoses / service procedure	Refer to page
Front heated seat driver side, passenger side and rear heated seat LH, RH do not operate.	Heated seat power supply circuit inspection.	SE-140
Front heated seat driver side and passenger side do not operate but the rear heated seat is operated.	Heated seat power supply circuit inspection.	SE-140
Front heated seat driver side or passenger side does not operate.	Front heated seat switch inspection.	SE-140
Front heated seat driver side or passenger side do not operate with LOW position and, seat cushion is not heated with HIGH position.	Front heated seat circuit inspection 1.	SE-141
Front heated seat driver side or passenger side do not operate with LOW position but seat cushion are heated with HIGH position.	Front heated seat circuit inspection 2.	SE-143
Front heated seat driver side or passenger side do not operate with HIGH position, seat cushion and seat back is heated with LOW position.	Front heated seat circuit inspection 3.	SE-145
Front heated seat with HIGH position is not warmer than LOW position.	Front heated seat switch ground circuit inspection.	SE-146
Rear heater seat LH and RH do not operated.	Rear heated seat power supply circuit inspection.	SE-147
Rear heater seat LH or RH do not operate.	1. Rear heated seat power supply and ground circuit inspection.	SE-148
	2. Rear power seat switch (Heater switch) ground circuit inspection.	SE-149
	3. Replace rear power seat control unit.	—
Rear heated seat driver side or passenger side do not operate with LOW position and, seat cushion is do not heated with HIGH position.	Rear heated seat circuit inspection 1.	SE-150
Rear heated seat driver side or passenger side do not operate with LOW position but seat cushion is heated with HIGH position.	Rear heated seat circuit inspection 2.	SE-151
Rear heated seat driver side or passenger side do not operate with HIGH position, seat cushion and seat back are heated with LOW position.	Rear heated seat circuit inspection 3.	SE-152
Rear heated seat driver side or passenger side switch LOW position do not operate and, when heated seat switch HIGH position, seat back and seat cushion is heated.	1. Rear heater seat switch LOW inspection.	SE-154
	2. Rear heater seat switch HIGH inspection.	SE-155
Rear heated seat with HIGH position is not warmer than LOW position.	Rear heated seat ground circuit inspection.	SE-156

A
B
C
D
E
F
G
H
SE
J
K
L
M

HEATED SEAT

EIS008M1

Heated Seat Power Supply Circuit Inspection

1. CHECK FUSIBLE LINK

Check 20A fuse (No.81, located in fuse block).

NOTE:

Refer to [SE-129, "Component Parts and Harness Connector Location"](#) .

OK or NG

OK >> GO TO 2.

NG >> If fuse is blown, be sure to eliminate cause of malfunction before installing new fuse, refer to [PG-2, "POWER SUPPLY ROUTING"](#) .

2. CHECK HEATED SEAT POWER SUPPLY CIRCUIT

1. Disconnect front heated seat switch connector.
2. Turn ignition switch ON.
3. Check voltage between front heated seat driver side switch connector M94 terminal 1 (W/B) and ground.

1 (W/B) – Ground : Battery voltage

OK or NG

OK >> Check the condition of the harness and connector.

NG >> Repair or replace harness between fuse block and front heated seat driver side switch.

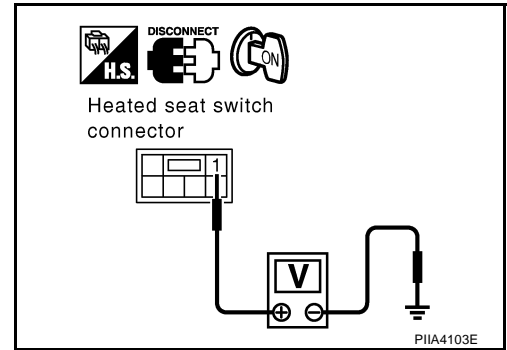

Front Heated Seat Switch Inspection

EIS008M2

1. CHECK FRONT HEATED SEAT POWER SUPPLY CIRCUIT

1. Disconnect front heated seat switch connector.
2. Turn ignition switch ON.
3. Check voltage between front heated seat switch connector M94 (driver side), M95 (passenger side) terminal 1 (W/B) and ground.

1 (W/B) – Ground : Battery voltage

OK or NG

OK >> GO TO 2.

NG >> Repair or replace harness between fuse block and front heated seat switch.

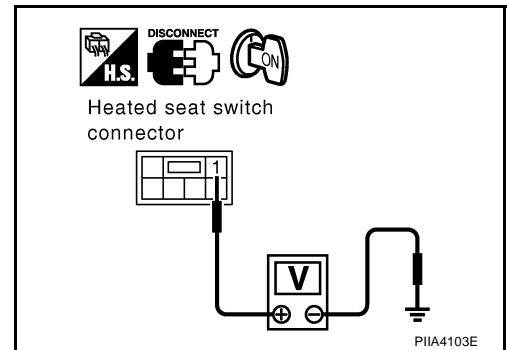

2. CHECK FRONT HEATED SEAT SWITCH

1. Turn ignition switch OFF.
2. Check continuity between front heated seat switch as follows.

Terminal	Condition	Continuity	
1	2	Front heated seat switch LOW.	YES
	3	Front heated seat switch HIGH.	YES
	2, 3	Other than above.	NO

OK or NG

OK >> Check the condition of the harness and connector.

NG >> Replace front heated seat switch.

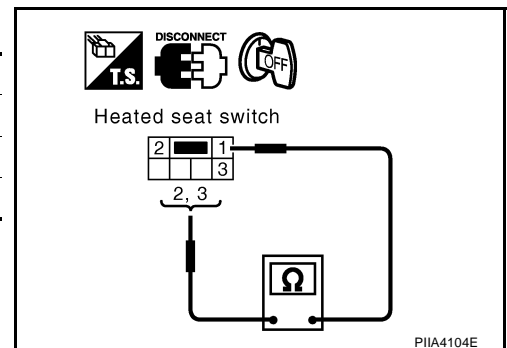

HEATED SEAT

EIS008M3

Front Heated Seat Circuit Inspection 1

1. CHECK FRONT HEATED SEAT SWITCH

1. Turn ignition switch OFF.
2. Disconnect front heated seat switch connector.
3. Check continuity between front heated side power seat switch.

Terminal		Condition	Continuity
3	4	Front heated seat switch LOW.	YES
		Other than above.	NO

OK or NG

- OK >> GO TO 2.
 NG >> Replace front heated seat switch.

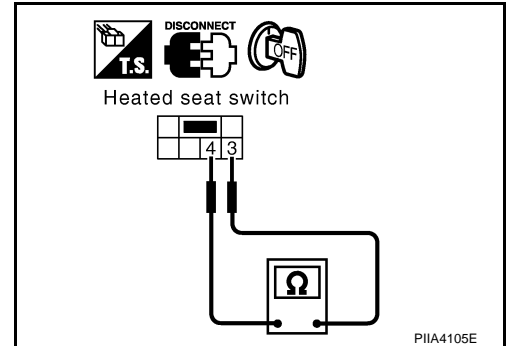

2. CHECK FRONT SEAT BACK HEATER CIRCUIT

1. Connect front heated seat switch connector.
2. Turn ignition switch ON.
3. Check voltage between front seat back heater connector and ground.

Connector	Terminal (Wire color)		Condition	Voltage (V) (Approx)
	(+)	(-)		
B152 (Driver side), B352 (Passenger side)	C (SB)	Ground	Turn ignition switch ON. Front heated seat switch LOW.	6.5
			Turn ignition switch ON. Front heated seat switch HIGH.	6.5
			Front heated seat switch OFF.	0

OK or NG

- OK >> GO TO 6.
 NG >> When turn ignition switch ON and heated switch ON (LOW, HIGH), check the following.
- When voltage is approx. 0V GO TO 3.
 - When voltage is approx. 12V GO TO 4.

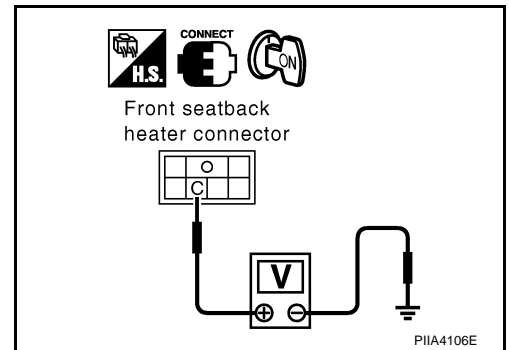

3. CHECK FRONT SEAT CUSHION HEATER HARNESS

1. Turn ignition switch OFF.
2. Disconnect front seat back heater connector and front seat cushion heater connector.
3. Check continuity between front seat back heater connector B152 (Driver side), B352 (Passenger side) terminal C (SB) and ground.

C (SB) – Ground :Continuity should exist

OK or NG

- OK >> Replace rear seat back.
 NG >> Repair or replace harness between front seat back and front seat cushion.

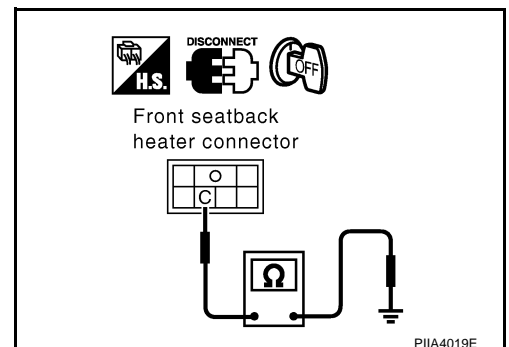

HEATED SEAT

4. CHECK FRONT SEAT CUSHION HEATER HARNESS

1. Turn ignition switch OFF.
2. Disconnect front seat back heater connector and front seat cushion heater connector.
3. Check continuity between front seat back heater connector B152 (Driver side), B352 (Passenger side) terminal C (SB) and front seat cushion heater connector B151 (Driver side), B351 (Passenger side) terminal C (SB).

C (SB) – C (SB) :Continuity should exist

OK or NG

OK >> GO TO 5.

NG >> Repair or replace harness between front seat back and front seat cushion.

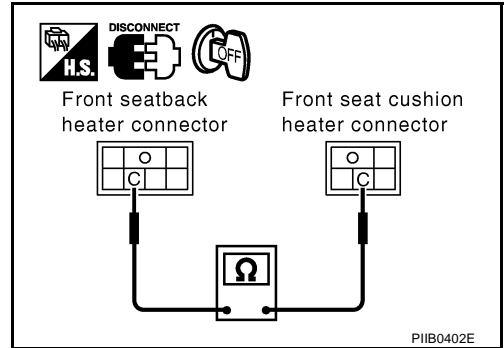

5. CHECK FRONT SEAT CUSHION GROUND HARNESS

Check continuity between front seat cushion heater connector B151 (Driver side), B351 (Passenger side) terminal 15C (B) and ground.

15C (B) – Ground :Continuity should exist

OK or NG

OK >> GO TO 6.

NG >> Repair or replace harness between front seat cushion heater and ground.

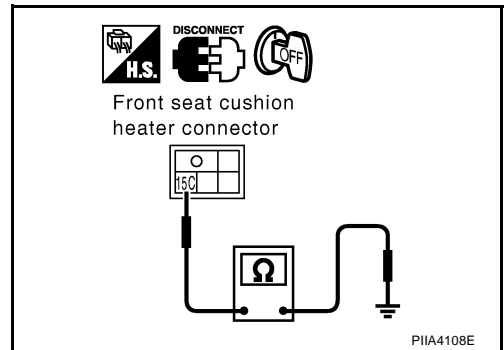

6. CHECK FRONT SEAT CUSHION

Does the heater operate normally when the seat cushion is exchanged?

Does seat cushion get warm?

YES >> Replace rear seatback.

NO >> Check connector for damage or loose connection.

HEATED SEAT

EIS008M4

Front Heated Seat Circuit Inspection 2

1. CHECK FRONT SEATBACK HEATER 1

1. Turn ignition switch ON.
2. Check voltage between front heated seat switch and ground.

Connector	Terminal (Wire color)		Condition	Voltage (V) (Approx.)
	(+)	(-)		
M94 (Driver side)	2 (L/W)	Ground	Turn ignition switch ON. Front heated seat switch LOW.	Battery voltage
			Front heated seat switch OFF.	0
M95 (Passenger side)	2 (P)	Ground	Turn ignition switch ON. Front heated seat switch LOW.	Battery voltage
			Front heated seat switch OFF.	0

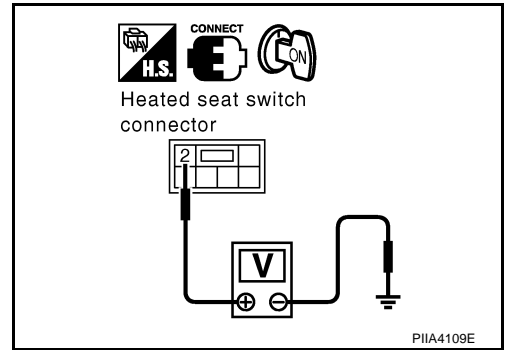

OK or NG

- OK >> GO TO 3.
NG >> GO TO 2.

2. CHECK FRONT HEATED SEAT SWITCH

1. Turn ignition switch OFF.
2. Disconnect front heated seat switch connector.
3. Check continuity between front heated seat switch as follows.

Terminal		Condition	Continuity
1	2	Front heated seat switch LOW.	YES
		Other than above.	NO

OK or NG

- OK >> Check connector for damage or loose connection.
NG >> Replace front heated seat switch.

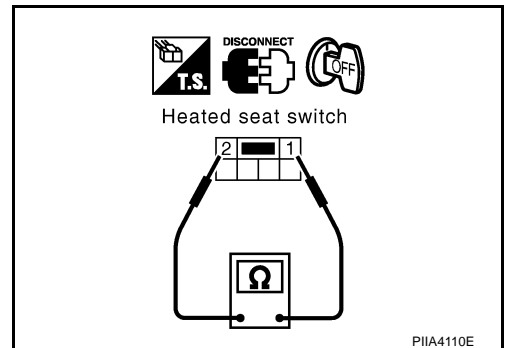

A
B
C
D
E
F
G
H
SE
J
K
L
M

HEATED SEAT

3. CHECK FRONT SEATBACK HEATER HARNESS

1. Turn ignition switch OFF.
2. Disconnect front heated seat switch connector and front seatback heater connector.
3. Check continuity between front heated seat switch connector M94(driver side), M95 (passenger side) terminal 2 and front seatback heater connector B152(driver side), B352(passenger side) terminal 62(L).

Driver side

2 (L/W) – 62 (L) : Continuity should exist

Passenger side

2 (P) – 62 (L) : Continuity should exist

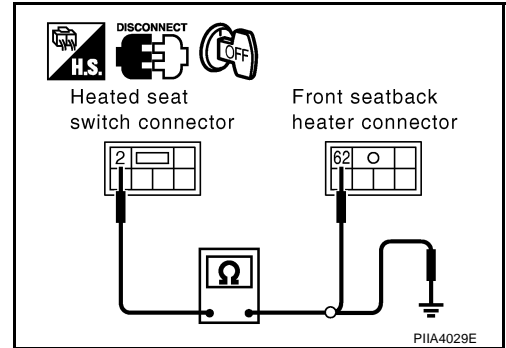

4. Check continuity between front heated seat switch connector M94(driver side), M95 (passenger side) terminal 2 and ground.

Driver side

2 (L/W) – Ground : Continuity should not exist

Passenger side

2 (P) – Ground : Continuity should not exist

OK or NG

OK >> GO TO 4.

NG >> Repair or replace harness between front heated seat switch and front seatback heater.

4. CHECK FRONT SEATBACK HEATER

Check continuity between front seatback heater B152 (driver side), B352 (passenger side) terminal C (SB) and 62 (L).

C (SB) – 62 (L) : Continuity should exist

OK or NG

OK >> Check the condition of the harness and connector.

NG >> Replace front seatback heater.

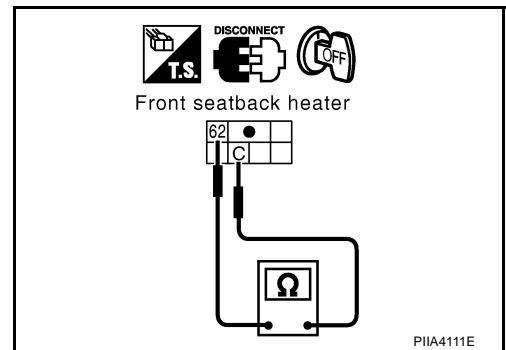

HEATED SEAT

EIS008M5

Front Heated Seat Circuit Inspection 3

1. CHECK FRONT HEATED SEAT SWITCH

1. Turn ignition switch ON.
2. Check voltage between front heated seat switch and ground.

Connector	Terminal (Wire color)		Condition	Voltage (V) (Approx.)
	(+)	(-)		
M94 (Driver side)	3 (R/Y)	Ground	Turn ignition switch ON. Front heated seat switch HIGH.	Battery voltage
			Front heated seat switch OFF.	0
M95 (Passenger side)	3 (Y)	Ground	Turn ignition switch ON. Front heated seat switch HIGH.	Battery voltage
			Front heated seat switch OFF.	0

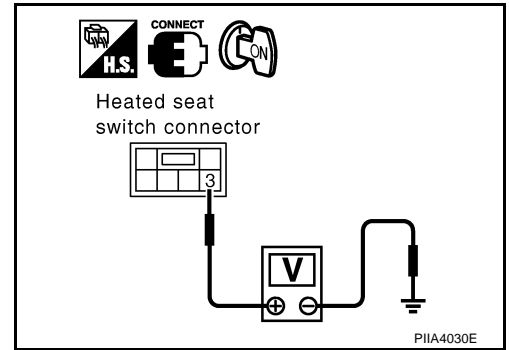

OK or NG

- OK >> GO TO 3.
NG >> GO TO 2.

2. CHECK FRONT HEATED SEAT SWITCH

1. Turn ignition switch OFF.
2. Disconnect front heated seat switch connector.
3. Check continuity between front heated seat switch as follows.

Terminal		Condition	Continuity
1	3	Front heated seat switch HIGH.	YES
		Other than above.	NO

OK or NG

- OK >> Check the condition of the harness and connector.
NG >> Replace front heated seat switch.

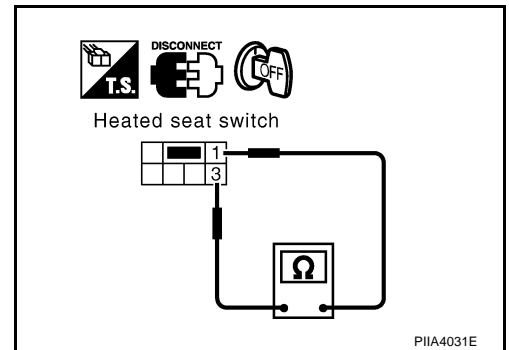

A
B
C
D
E
F
G
H
SE
J
K
L
M

HEATED SEAT

3. CHECK FRONT SEATBACK HEATER HARNESS

1. Turn ignition switch OFF.
2. Disconnect front heated seat switch connector and front seatback heater connector.
3. Check continuity between front heated seat switch connector M94(driver side), M95 (passenger side) terminal 3 and front seatback heater connector B152(driver side), B352(passenger side) terminal 63(B).

Driver side

3 (R/Y) – 63 (B) : Continuity should exist

Passenger side

3 (Y) – 63 (B) : Continuity should exist

4. Check continuity between front heated seat switch connector M94(driver side), M95 (passenger side) terminal 3 and ground.

Driver side

3 (R/Y) – Ground : Continuity should not exist

Passenger side

3 (Y) – Ground : Continuity should not exist

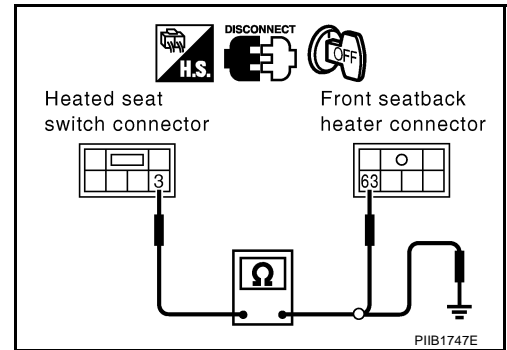

OK or NG

OK >> GO TO 4.

NG >> Repair or replace harness between front heated seat switch and front seatback heater.

4. CHECK FRONT SEATBACK HEATER

Check continuity between front seatback heater B152 (driver side), B352 (passenger side) terminal C (SB) and 63 (B).

C (SB) – 63 (B) : Continuity should exist

OK or NG

OK >> Check the condition of the harness and connector.

NG >> Replace front seatback heater.

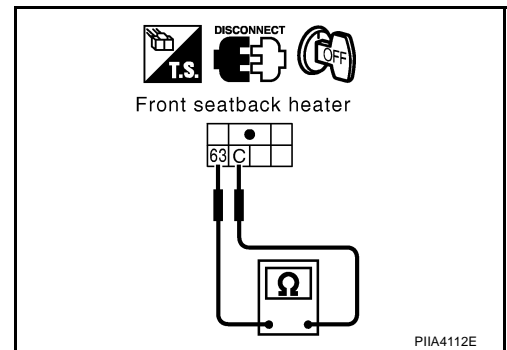

Front Heated Seat Switch Ground Circuit Inspection

EIS008M6

1. CHECK FRONT HEATED SEAT SWITCH

1. Turn ignition switch OFF.
2. Disconnect front heated seat switch connector.
3. Check continuity between front heated seat switch as follows.

Terminal		Condition	Continuity
2	4	Front heated seat switch HIGH.	YES
		Other than above.	NO

OK or NG

OK >> GO TO 2.

NG >> Replace front heated seat switch.

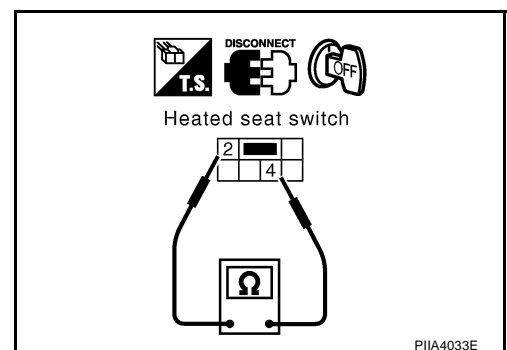

HEATED SEAT

2. CHECK FRONT HEATED SEAT SWITCH GROUND HARNESS

Check continuity between front heated seat switch connector M94 (Driver side), M95 (passenger side) terminal 4 (B) and ground.

4 (B) – Ground : Continuity should exist

OK or NG

- OK >> Check connector for damage or loose connection.
- NG >> Repair or replace harness between front heated seat switch and ground.

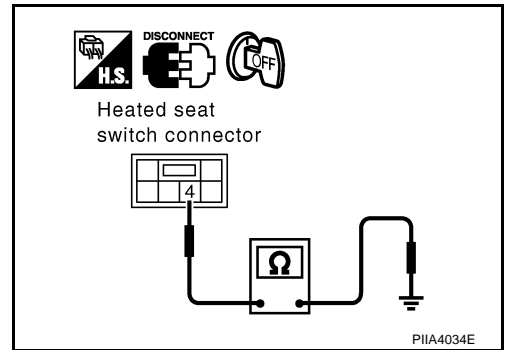

Rear Power Seat Control Unit Power Supply Circuit Inspection 1

EIS008M7

1. CHECK REAR POWER SEAT OPERATION

Does the rear power seat operate normally?

YES or NO

- YES >> GO TO 4.
- NO >> GO TO 2.

2. CHECK FUSIBLE LINK

Check 40A fusible link (letter H located in the fuse and fusible link box).

NOTE:

Refer to [SE-129, "Component Parts and Harness Connector Location"](#).

OK or NG

- OK >> GO TO 3.
- NG >> If fuse is blown, be sure to eliminate cause of malfunction before installing new fuse, refer to [PG-2, "POWER SUPPLY ROUTING"](#).

3. CHECK REAR POWER SEAT CONTROL UNIT BATTERY POWER SUPPLY CIRCUIT

1. Disconnect rear power seat control unit connector.
2. Check voltage between rear power seat control unit connector B162 (LH), B362 (RH) terminal 2 (G) and ground.

2 (G) – Ground : Battery voltage

OK or NG

- OK >> Check the condition of the harness connector.
- NG >> Repair or replace harness between fuse block (J/B) and rear power seat control unit.

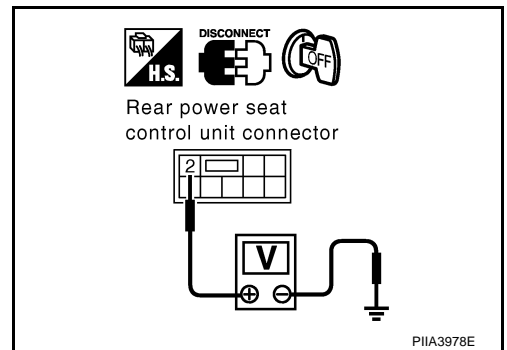

HEATED SEAT

4. CHECK REAR POWER SEAT CONTROL UNIT IGNITION POWER SUPPLY CIRCUIT

1. Check the condition of the harness and connector.
2. Turn ignition switch ON.
3. Check voltage between rear power seat control unit connector B162 (LH), B362 (RH) connector terminal 44 (GY/B) and ground.

44 (GY/B) – Ground : Battery voltage

OK or NG

- OK >> Check the condition of the harness and connector.
NG >> Repair or replace harness between fuse block (J/B) and rear power seat control unit.

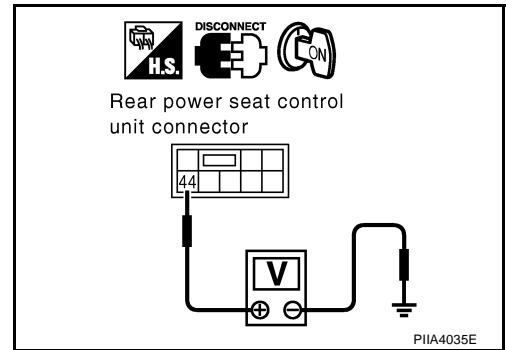

Rear Power Seat Control Unit Power Supply and Ground Circuit Inspection EIS008M8

1. CHECK REAR POWER SEAR OPERATION

Does the rear power seat operate normally?

YES or NO

- YES >> GO TO 4.
NO >> GO TO 2.

2. CHECK REAR POWER SEAT CONTROL UNIT POWER SUPPLY CIRCUIT

1. Turn ignition switch OFF.
2. Disconnect rear power seat control unit connector.
3. Check voltage between rear power seat control unit connector B162 (LH), B362 (RH) terminal 2 (G) and ground.

2 (G) – Ground : Battery voltage

OK or NG

- OK >> GO TO 3.
NG >> Repair or replace harness between fuse block (J/B) and rear power seat control unit.

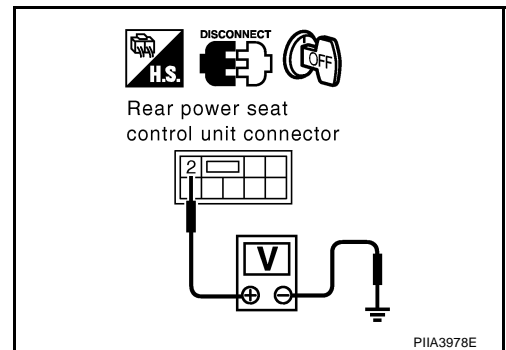

3. CHECK REAR POWER SEAT CONTROL UNIT GROUND CIRCUIT

Check continuity between rear power seat control unit connector B162 (LH), B362 (RH) terminal 15 (B) and ground.

15 (B) – Ground : Continuity should exist

OK or NG

- OK >> Replace rear power seat control unit.
NG >> Repair or replace harness between rear power seat control unit and ground.

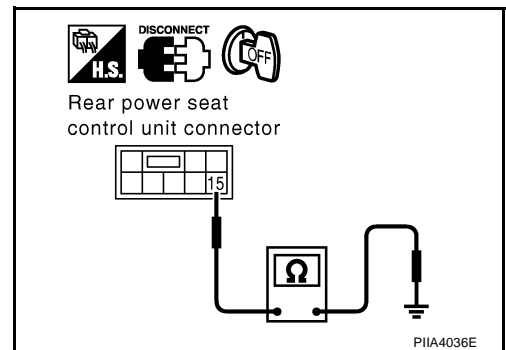

HEATED SEAT

4. CHECK REAR POWER SEAT CONTROL UNIT POWER SUPPLY CIRCUIT

1. Disconnect rear power seat control unit connector.
2. Turn ignition switch ON.
3. Check voltage between rear power seat control unit B162 (LH), B362 (RH) connector terminal 44 (GY/B) and ground.

44 (GY/B) – Ground : Battery voltage

OK or NG

- OK >> Check the condition of the harness and connector.
 NG >> Repair or replace harness between fuse block (J/B) and rear power seat control unit.

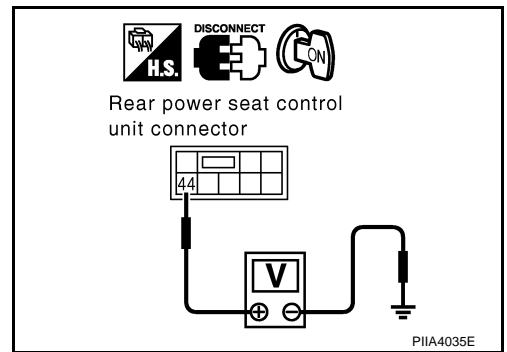

Rear Power Seat Switch (Heater Switch) Ground Circuit Inspection

EIS008M9

1. CHECK REAR POWER SEAT SWITCH (HEATER SWITCH)

1. Turn ignition switch OFF.
2. Disconnect rear power seat switch (Heater switch) connector.
3. Check continuity between rear power seat switch (heater switch) as follows.

Terminal	Condition	Continuity
5, 6	Rear heater switch LOW.	YES
	Rear heater switch HIGH.	YES
	Other than above.	NO

OK or NG

- OK >> GO TO 2.
 NG >> Replace rear power seat switch (Heater switch).

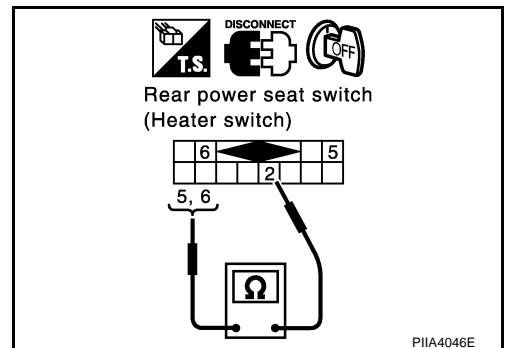

2. CHECK REAR POWER SEAT SWITCH (HEATER SWITCH) GROUND CIRCUIT

Check continuity between rear power seat switch (heater switch) connector D55 (LH), D75 (RH) terminal 2 (B) and ground.

2 (B) – Ground : Continuity should exist

OK or NG

- OK >> Rear power seat switch (heater switch) ground circuit check is OK.
 NG >> Repair or replace harness between rear power seat switch (heater switch) and ground.

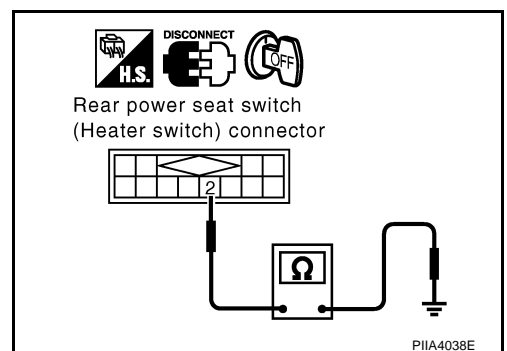

HEATED SEAT

EIS008MA

Rear Heated Seat Circuit Inspection

1. CHECK REAR SEAT CUSHION HEATER POWER SUPPLY

1. Turn ignition switch ON.
2. Check voltage between rear seatback heater and ground.

Connector	Terminal (Wire color)		Condition	Voltage (V) (Approx.)
	(+)	(-)		
B165 (LH), B365 (RH)	A (Y/B)	Ground	Turn ignition switch ON. Heater switch LOW.	6.0
			Turn ignition switch ON. Heater switch HIGH.	6.0
			Heater switch OFF.	0

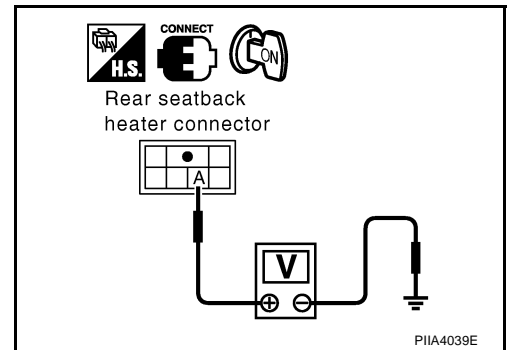

OK or NG

OK >> GO TO 5.

NG >> When turn ignition switch ON and heater switch LOW position or HIGH position check the following.

- When voltage is approx. 0V, GO TO 2.
- When voltage is approx. 12V, GO TO 3.

2. CHECK REAR SEAT CUSHION HEATER HARNESS

1. Turn ignition switch OFF.
2. Disconnect rear seatback heater connector and front seat cushion heater connector.
3. Check continuity between rear seatback connector B165 (LH), B365 (RH) terminal A (Y/B) and ground.

A (Y/B) – Ground :Continuity should not exist

OK or NG

OK >> Replace rear seatback.

NG >> Repair or replace harness between rear seatback and rear seat cushion.

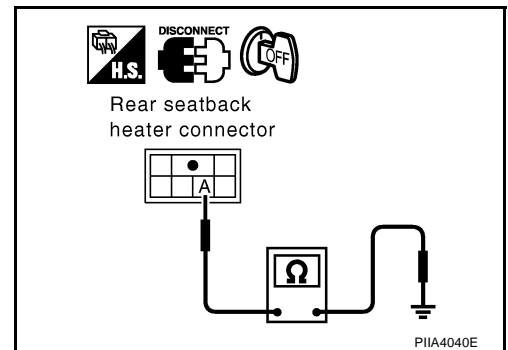

3. CHECK REAR SEAT CUSHION HEATER HARNESS

1. Turn ignition switch OFF.
2. Disconnect rear seatback heater connector and front seat cushion heater connector.
3. Check continuity between rear seatback connector B165 (LH), B365 (RH) terminal A (Y/B) and rear seat cushion connector B166 (LH), B366 (RH) terminal A (Y/B).

A (Y/B) – A (Y/B) :Continuity should exist

OK or NG

OK >> GO TO 4.

NG >> Repair or replace harness between rear seatback and rear seat cushion.

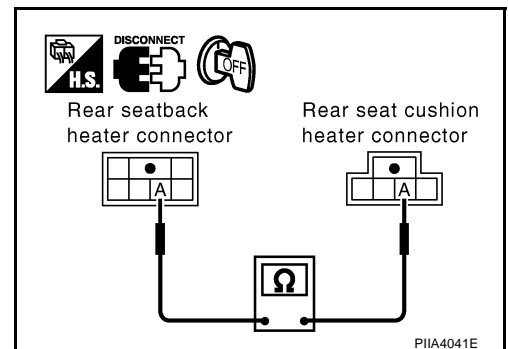

HEATED SEAT

4. CHECK REAR SEAT CUSHION HEATER GROUND CIRCUIT

Check continuity between rear seat cushion heater connector B166 (LH), B366 (RH) terminal 15B (B) and ground.

15B (B) – Ground :Continuity should exist

OK or NG

- OK >> Rear rear heated seat cushion circuit inspection is OK.
- NG >> Repair or replace harness between rear seat cushion heater and ground.

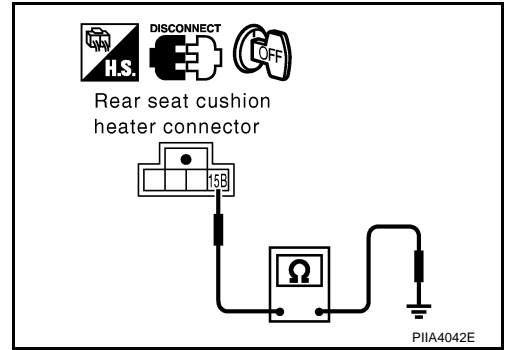

5. CHECK FRONT SEAT CUSHION

Does the heater operate normally when the seat cushion is exchanged?

Does seat cushion get warm?

- YES >> Replace rear seat cushion.
- NO >> Check connector for damage or loose connection.

Rear Heated Seat Circuit Inspection 2

EIS008MB

1. CHECK REAR SEATBACK HEATER POWER SUPPLY

1. Turn ignition switch ON.
2. Check voltage between rear power seat control unit connector and ground.

Con- nector	Terminal (Wire color)		Condition	Voltage (V) (Approx.)
	(+)	(-)		
B162 (LH), B362 (RH)	8 (OR)	Ground	Turn ignition switch ON. Heater switch LOW.	Battery voltage
			Heater switch OFF.	0

OK or NG

- OK >> GO TO 3.
- NG >> GO TO 2.

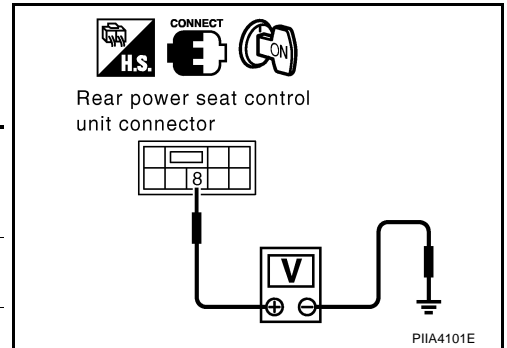

2. CHECK REAR SEAT BACK HEATER HARNESS

1. Turn ignition switch OFF.
2. Disconnect rear seat control unit connector and rear seatback heater connector.
3. Check continuity between rear seat control unit connector B162 (LH), B362 (RH) terminal 8 (OR) and ground.

8 (OR) – Ground :Continuity should not exist

OK or NG

- OK >> Replace rear seat control unit.
- NG >> Repair or replace harness between rear seat control unit and seatback heater.

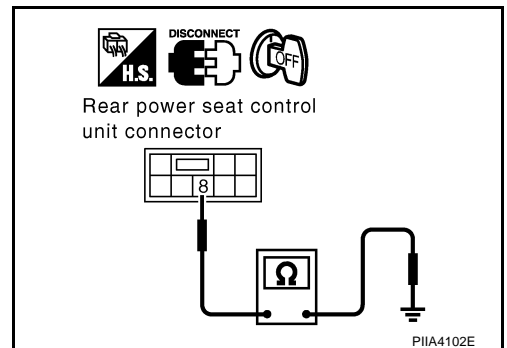

HEATED SEAT

3. CHECK REAR SEATBACK HEATER HARNESS

1. Turn ignition switch OFF.
2. Disconnect rear seat control unit connector and rear seatback heater connector.
3. Check continuity between rear seat control unit connector B162 (LH), B362 (RH) terminal 8 (OR) and rear seatback heater connector B165 (LH), B365 (RH) terminal 8 (OR).

8 (OR) – 8 (OR) :Continuity should exist

OK or NG

OK >> GO TO 4.

NG >> Repair or replace harness between rear seat control unit and rear seatback heater.

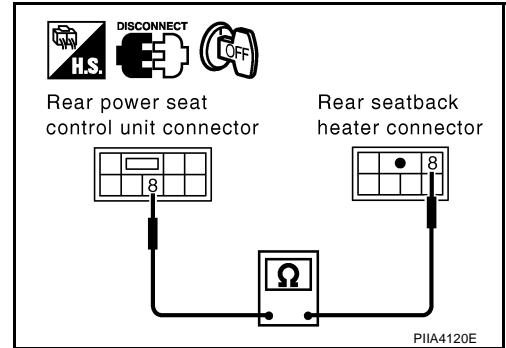

4. CHECK REAR SEATBACK HEATER

Check continuity between rear seatback heater B165 (LH), B365 (RH) terminal A (Y/B) and 8 (OR).

A (Y/B) – 8 (OR) : Continuity should exist

OK or NG

OK >> Check the condition of the harness and connector.

NG >> Replace rear seatback heater.

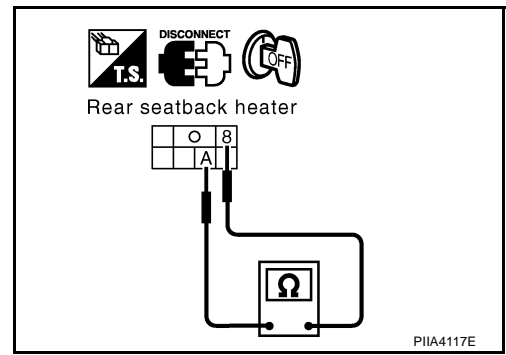

Rear Heated Seat Circuit Inspection 3

1. CHECK REAR SEATBACK HEATER POWER SUPPLY

1. Turn ignition switch ON.
2. Check voltage between rear power seat control unit connector and ground.

Con- nector	Terminal (Wire color)		Condition	Voltage (V) (Approx.)
	(+)	(-)		
B162 (LH), B362 (RH)	5 (BR)	Ground	Turn ignition switch ON. Heater switch HIGH.	Battery voltage
			Heater switch OFF.	0

OK or NG

OK >> GO TO 3.

NG >> GO TO 2.

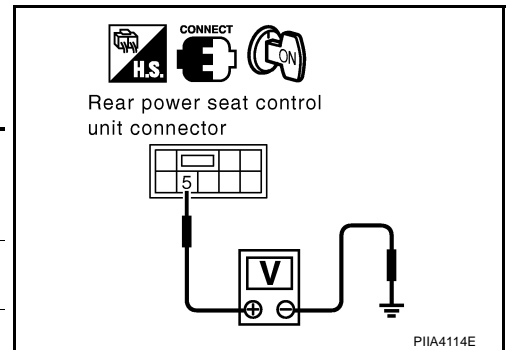

HEATED SEAT

2. CHECK REAR SEAT BACK HEATER HARNESS

1. Turn ignition switch OFF.
2. Disconnect rear seat control unit connector and rear seatback heater connector.
3. Check continuity between rear seat control unit connector B162 (LH), B362 (RH) terminal 5 (BR) and ground.

5 (BR) – Ground :Continuity should not exist

OK or NG

- OK >> Replace rear power seat control unit.
NG >> Repair or replace harness between rear power seat control unit and rear seatback heater.

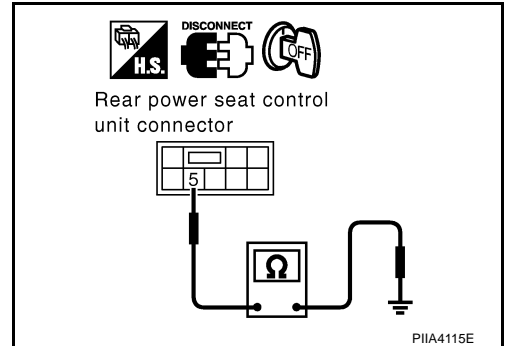

3. CHECK REAR SEAT BACK HEATER HARNESS

1. Turn ignition switch OFF.
2. Disconnect rear seat control unit connector and rear seatback heater connector.
3. Check continuity between rear seat control unit connector B162 (LH), B362 (RH) terminal 5 (BR) and rear seatback heater connector B165 (LH), B365 (RH) terminal 5 (BR).

5 (BR) – 5 (BR) :Continuity should exist

OK or NG

- OK >> GO TO 4.
NG >> Repair or replace harness between rear power seat control unit and rear seatback heater.

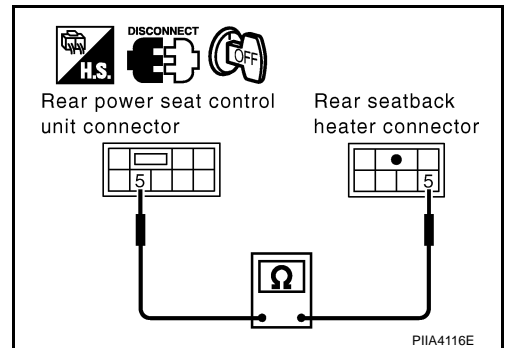

4. CHECK REAR SEATBACK HEATER

Check continuity between rear seatback heater B165 (LH), B365 (RH) terminal A (Y/B) and 5 (BR).

A (Y/B) – 5 (BR) : Continuity should exist

OK or NG

- OK >> Check the condition of the harness and connector.
NG >> Replace rear seatback heater.

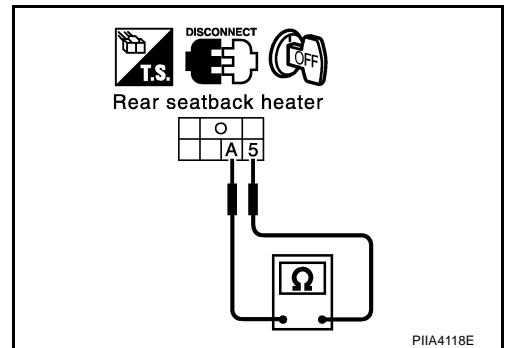

HEATED SEAT

EIS008MD

Rear Heated Seat Switch Low Circuit Inspection

1. CHECK REAR HEATER SWITCH POWER SUPPLY

1. Turn ignition switch ON.
2. Check voltage between rear power seat control unit connector and ground.

Con- nector	Terminal (Wire color)		Condition	Voltage (V) (Approx.)
	(+)	(-)		
B163 (LH), B363 (RH)	32 (LG/W)	Ground	Turn ignition switch ON. Heater switch LOW.	0
			Heater switch OFF.	5

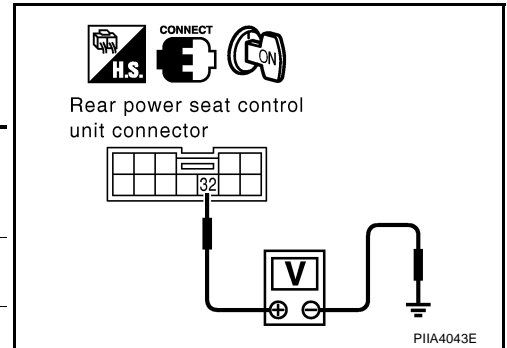

OK or NG

- OK >> Replace rear power seat control unit.
 NG >> When turn ignition switch ON and heater switch LOW, check the following.
- When voltage is approx. 0V, GO TO 2.
 - When voltage is approx. 5V, GO TO 3.

2. CHECK REAR POWER SEAT SWITCH (HEATER SWITCH) HEATER HARNESS

1. Turn ignition switch OFF.
2. Disconnect rear seat control unit connector and rear power seat switch (heater switch) connector.
3. Check continuity between rear seat control unit connector B163 (LH), B363 (RH) terminal 32 (LG/W) and ground.

32 (LG/W) – Ground :Continuity should not exist

OK or NG

- OK >> Replace rear power seat control unit.
 NG >> Repair or replace harness between rear power seat control unit and rear power seat switch (heater switch).

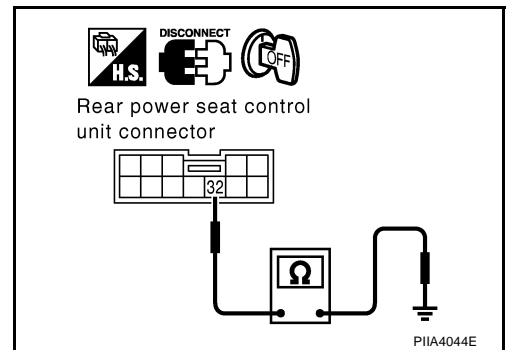

3. CHECK REAR POWER SEAT SWITCH (HEATER SWITCH) HEATER HARNESS

1. Turn ignition switch OFF.
2. Disconnect rear power seat control unit connector and rear power seat switch (heater switch) connector.
3. Check continuity between rear power seat control unit connector B163 (LH), B363 (RH) terminal 32 (LG/W) and rear power seat switch (heater switch) connector D55 (LH), D75 (RH) terminal 5 (L/W) (LH), 6 (Y/R) (RH).

**Rear seat LH
 32 (LG/W) – 5 (L/W) :Continuity should exist**

**Rear seat RH
 32 (LG/W) – 6 (Y/R) :Continuity should exist**

OK or NG

- OK >> GO TO 4.
 NG >> Repair or replace harness between rear power seat control unit and rear power seat switch (heater switch).

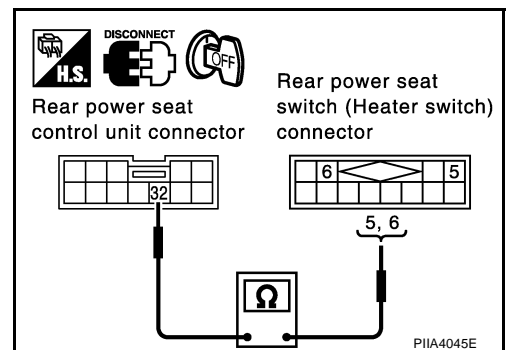

HEATED SEAT

4. CHECK REAR POWER SEAT SWITCH (HEATER SWITCH)

Check continuity between rear power seat switch (heater switch).

Terminal	Condition	Continuity
5 (LH) 6 (RH)	Rear heater switch LOW.	YES
	Other than above.	NO

OK or NG

- OK >> Check the condition of the harness and connector.
 NG >> Replace rear power seat switch (heater switch).

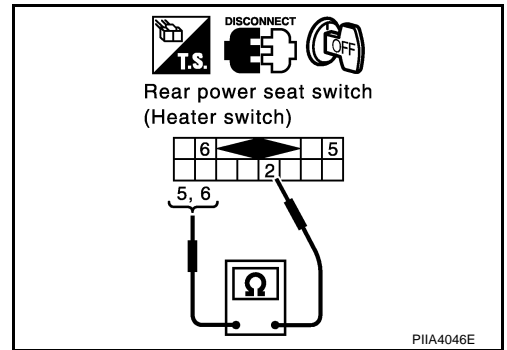

Rear Heated Seat Switch High Circuit Inspection

1. CHECK REAR HEATER SWITCH POWER SUPPLY

- Turn ignition switch ON.
- Check voltage between rear power seat control unit connector and ground.

Con- nector	Terminal (Wire color)		Condition	Voltage (V) (Approx.)
	(+)	(-)		
B163 (LH), B363 (RH)	22 (L/W)	Ground	Turn ignition switch ON. Heater switch HIGH.	0
			Heater switch OFF.	5

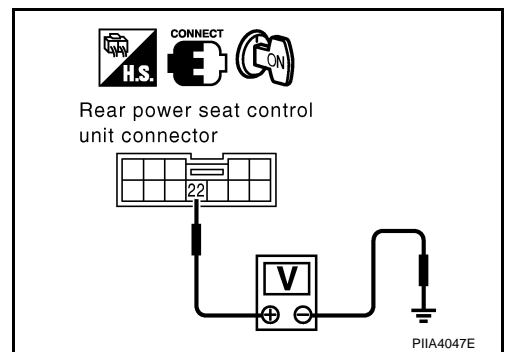

OK or NG

- OK >> Rear heated seat HIGH circuit inspection is OK.
 NG >> When turn ignition switch ON and heater switch HIGH, check the following.
- When voltage is approx. 0V, GO TO 2.
 - When voltage is approx. 5V, GO TO 3.

2. CHECK REAR POWER SEAT SWITCH (HEATER SWITCH) HEATER HARNESS

- Turn ignition switch OFF.
- Disconnect rear seat control unit connector and rear power seat switch (heater switch) connector.
- Check continuity between rear seat control unit connector B163 (LH), B363 (RH) terminal 22 (L/W) and ground.

22 (L/W) – Ground :Continuity should not exist

OK or NG

- OK >> Replace rear power seat control unit.
 NG >> Repair or replace harness between rear power seat control unit and rear power seat switch (heater switch).

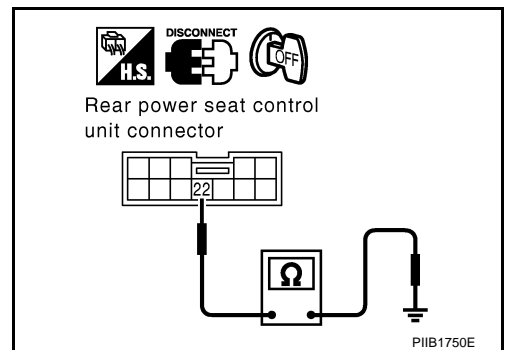

HEATED SEAT

3. CHECK REAR POWER SEAT SWITCH (HEATER SWITCH) HEATER HARNESS

1. Turn ignition switch OFF.
2. Disconnect rear power seat control unit connector and rear power seat switch (heater switch) connector.
3. Check continuity between rear power seat control unit connector B163 (LH), B363 (RH) terminal 22 (L/W) and rear power seat switch (heater switch) connector D55 (LH), D75 (RH) terminal 5 (L/W) (RH), 6 (Y/R) (LH).

Rear seat LH

22 (L/W) – 6 (Y/R) :Continuity should exist

Rear seat RH

22 (L/W) – 5 (L/W) :Continuity should exist

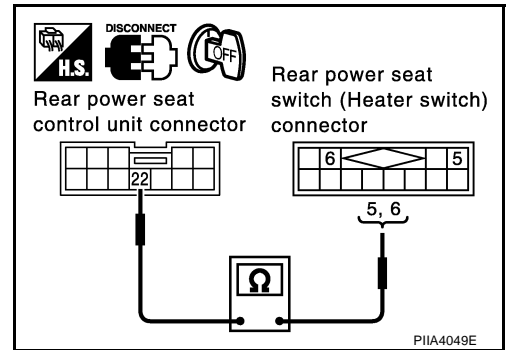

OK or NG

OK >> GO TO 4.

NG >> Repair or replace harness between rear power seat control unit and rear power seat switch (heater switch).

4. CHECK REAR POWER SEAT SWITCH (HEATER SWITCH)

Check continuity between rear power seat switch (heater switch).

Terminal	Condition	Continuity
5 (RH) 6 (LH)	2	Rear heater switch HIGH. Should exist
		Other than above. Should not exist

OK or NG

OK >> Check the condition of the harness and connector.

NG >> Replace front power seat switch (heater switch).

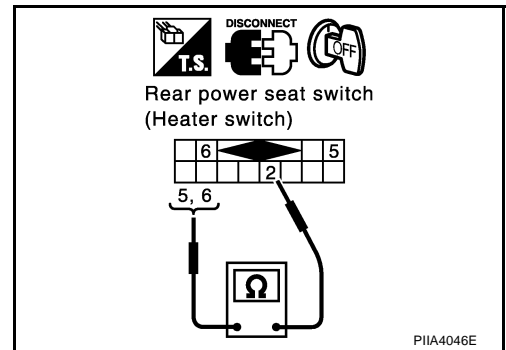

Rear Heated Seat Ground Circuit Inspection

1. CHECK REAR SEAT BACK HEATER HARNESS

1. Turn ignition switch OFF.
2. Disconnect rear seat control unit connector.
3. Check continuity between rear seat control unit connector B162 (LH), B362 (RH) terminal 8 (OR) and 15 (B).

8 (OR) – 15 (B) :Continuity should exist

OK or NG

OK >> Check the condition of the harness and connector.

NG >> Replace rear power seat control unit.

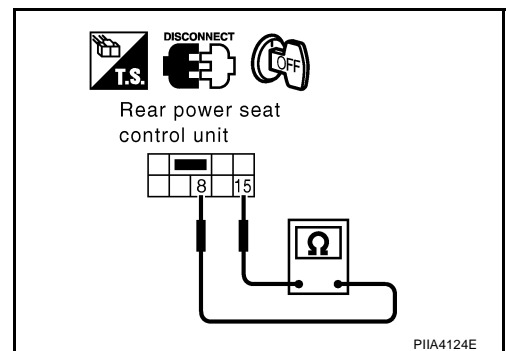

CLIMATE CONTROLLED SEAT

PFP:870U6

System Description

EIS008MG

The climate controlled seat system is controlled by climate controlled seat control unit. Heating and cooling are possible for a Thelma electric device (heat conversion machine).

NOTE:

- The climate controlled seat system is downed when the temperature sensor set as the seat cushion and the seat back's thermal electric device machine detects 20 °C (68 °F) or more of mutual differences of temperature.
- In this case, by turning off ignition switch, system down is canceled and it can be reused by turning on ignition switch again.
- The climate controlled seat blower keep low speed for approximately 60 seconds after turning the temperature switch or the dial.

CAUTION:

- **The thermal electric device has the character in which, as for an opposite side. one side becomes high temperature at the time of low temperature.**
- **At the time of work, please turn OFF a switch, and carry it out after checking that the thermal electric device has got cold.**

Power is at all times supplied

- through 15A fuse [No. 71, and 72, located in the fuse fusible link and relay unit]
- to climate controlled seat relay terminals 5 and 7.

When the ignition switch turned to ON or START position,
Power is supplied

- through 10A fuse [No. 1, located in the fuse block (J/B)]
- to climate controlled seat relay terminal 2, and
- to climate controlled seat control unit (driver side and passenger side) terminal JD.

Then ground is supplied

- to climate controlled seat relay terminal 1,
- through body grounds E42, and E 62.

Then climate controlled seat relay is energized,
When climate controlled seat relay is turned to ON,
Power is supplied,

- through climate controlled seat relay terminal 3,
- to driver side climate controlled seat control unit terminal JB.

When climate controlled seat relay is turned to ON,
Power is supplied,

- through climate controlled seat relay terminal 6,
- to passenger side climate controlled seat control unit terminal JB.

When climate controlled switch select "HEAT", ground is supply

- through climate controlled seat switch terminal J6,
- to climate controlled seat control unit terminal J6,
- through climate controlled seat switch terminal JCA,
- through body grounds B17 and B57.

Then, the climate controlled control unit receives climate controlled switch "HEAT" signal.

When climate controlled switch select "COOL", ground is supply

- through climate controlled seat switch terminal J16,
- to climate controlled seat control unit terminal J16,
- through climate controlled seat switch terminal JCA,
- through body grounds B17 and B57.

Then, the climate controlled control unit receives climate controlled switch "COOL" signal.

When the climate controlled seat control unit receives climate controlled seat switch signal, power is supply

- to climate controlled seat temperature dial terminal J7,

CLIMATE CONTROLLED SEAT

- through climate controlled seat control unit terminal J7.

And then ground is supplied

- through climate controlled seat control unit terminal J15,
- to climate controlled seat temperature dial terminal J15.

Then, the climate controlled seat control unit receives climate controlled seat temperature dial signal.

When blower motor rotates, signal is transmitted

- to climate controlled seat control unit terminal J14,
- through climate controlled seat blower motor terminal J14.

This is climate controlled seat blower motor tachometer signal.

When climate controlled seat control unit receives climate controlled seat switch (HEAT, COOL) signal, climate controlled seat temperature dial signal and tachometer signal,

Power is supplied

- to climate controlled seat blower motor terminal J13,
- through climate controlled seat control unit terminal J13.

This is blower motor revolution control signal.

When blower motor receives blower motor revolution control signal,

Power is supplied

- through climate controlled seat control unit terminal J10,
- to climate controlled seat blower motor terminal J10.

When number of rotations correspond signal,

Ground is supplied

- to climate controlled seat blower motor terminal J3,
- through climate controlled seat control unit terminal J3,
- through climate controlled seat control unit terminal JC,
- through body grounds B217 and B256.

Then motor revolution is controlled.

When the ignition switch turned to ON or START position,

Power is supplied

- to climate controlled seat cushion thermal electric device terminal J18,
- through climate controlled seat control unit terminal J18.

Then ground is supplied

- to climate controlled seat control unit terminal J17,
- through climate controlled seat cushion thermal electric device terminal J17,

Then the climate controlled seat control unit recognizes seat cushion thermal electric device sensor signal.

When climate controlled control unit recognizes climate controlled switch "HEAT" signal and, seat cushion thermal electric device sensor signal,

Power is supplied

- to climate controlled seat cushion thermal electric device terminal J1,
- through climate controlled seat control unit terminal J1.

Then ground is supplied

- through climate controlled seat cushion thermal electric device terminal J2,
- to climate controlled seat control unit terminal J2,
- through climate controlled seat control unit terminal JC,
- through body grounds B217 and B256.

When climate controlled control unit recognizes climate controlled switch "COOL" signal and, climate controlled seat cushion thermal electric device sensor signal,

Power is supplied

- to climate controlled seat cushion thermal electric device terminal J2,
- through climate controlled seat control unit terminal J2.

Then ground is supplied

- through climate controlled seat cushion thermal electric device terminal J1,
- to climate controlled seat control unit terminal J1.

CLIMATE CONTROLLED SEAT

- through climate controlled seat control unit terminal JC,
- through body grounds B217 and B256.

When the ignition switch turned to ON or START position,
Power is supplied

- to climate controlled seatback thermal electric device terminal J19,
- through climate controlled seat control unit terminal J19.

Then ground is supplied

- to climate controlled seat control unit terminal J20,
- through climate controlled seatback thermal electric device terminal J20,
- through climate controlled seat control unit terminal JC,
- through body grounds B217 and B256.

Then the climate controlled seat control unit recognizes seatback thermal electric device sensor signal.

When climate controlled control unit recognizes climate controlled switch "HEAT" signal and climate controlled seatback thermal electric device sensor signal,
Power is supplied

- to climate controlled seatback thermal electric device terminal J11,
 - through climate controlled seat control unit terminal J11,
- ground is supplied

- to climate controlled seat control unit terminal J12,
- through climate controlled seatback thermal electric device terminal J12,
- through climate controlled seat control unit terminal JC,
- through body grounds B217 and B256.

this climate controlled seatback thermal electric device generates heat wind is warmed.

When climate controlled control unit recognizes climate controlled switch "COOL" signal and climate controlled seatback thermal electric device sensor signal,
Power is supplied

- to climate controlled seatback thermal electric device terminal J12,
 - through climate controlled seat control unit terminal J12,
- ground is supplied

- to climate controlled seat control unit terminal J11,
- through climate controlled seatback thermal electric device terminal J11,
- through climate controlled seat control unit terminal JC,
- through body grounds B217 and B256.

When climate controlled switch selects "HEAT",
Power is supplied

- to climate controlled seat switch terminal J4,
- through climate controlled seat control unit terminal J4.

Ground is supplied

- to the climate controlled seat switch terminal JCA,
- through body grounds B17 and B57.

Then climate controlled seat switch "HEAT" indicator is energized.

When climate controlled switch select "COOL",
Power is supplied

- to climate controlled seat switch terminal J5,
- through climate controlled seat control unit terminal J5.

Ground is supplied

- to the climate controlled seat switch terminal JCA,
- through body grounds B17 and B57.

Then climate controlled seat switch "COOL" indicator is energized.

A

B

C

D

E

F

G

H

SE

J

K

L

M

CLIMATE CONTROLLED SEAT

EIS008MH

Component Parts and Harness Connector Location

Dash side LH

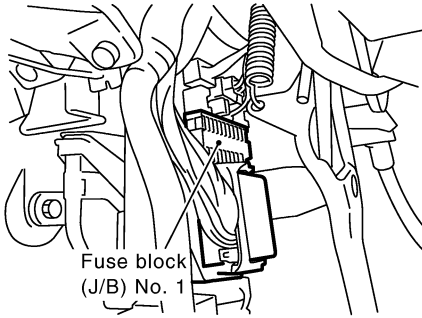

Fuse block (J/B) No. 1

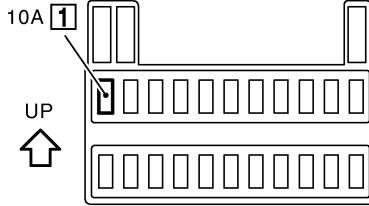

Fuse, fusible link and relay box

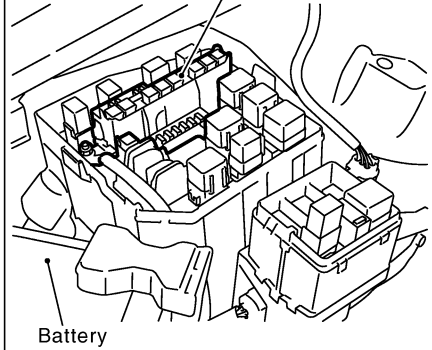

Fuse, fusible link and relay box

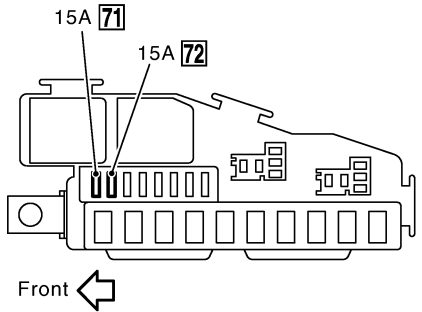

Front seat driver side

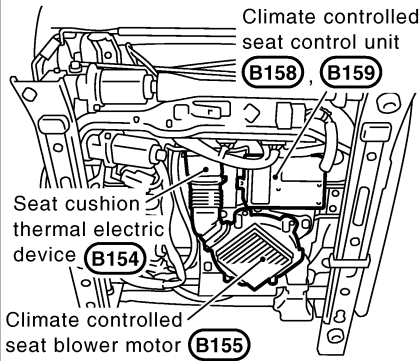

Front seat driver side

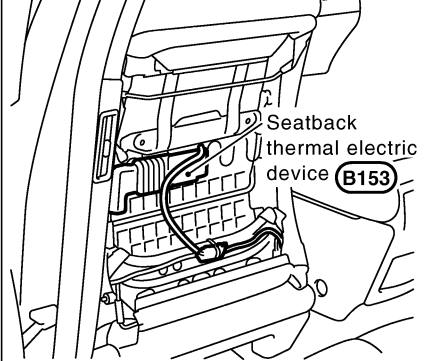

Front seat driver side

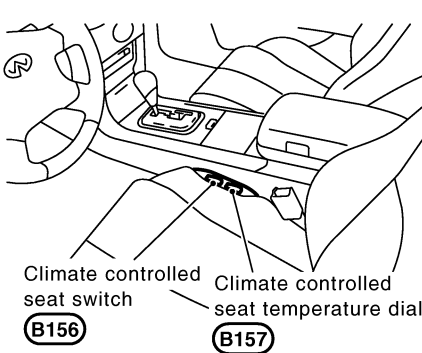

Front seat passenger side

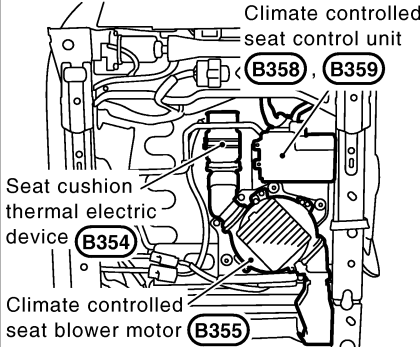

Front seat passenger side

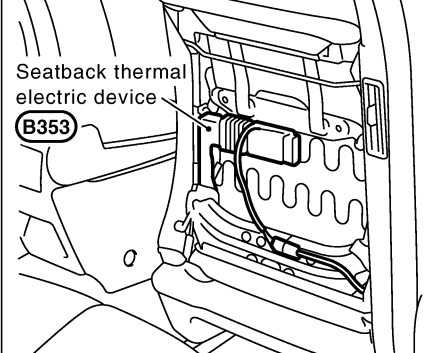

Front seat passenger side

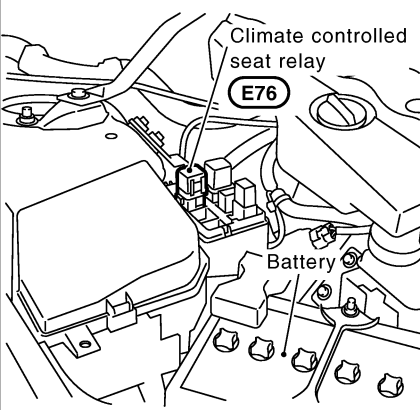
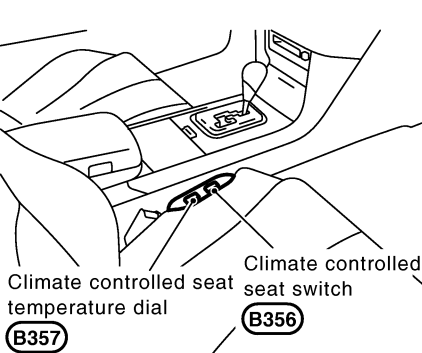

PIIA7231E

CLIMATE CONTROLLED SEAT

Schematic

EIS008MI

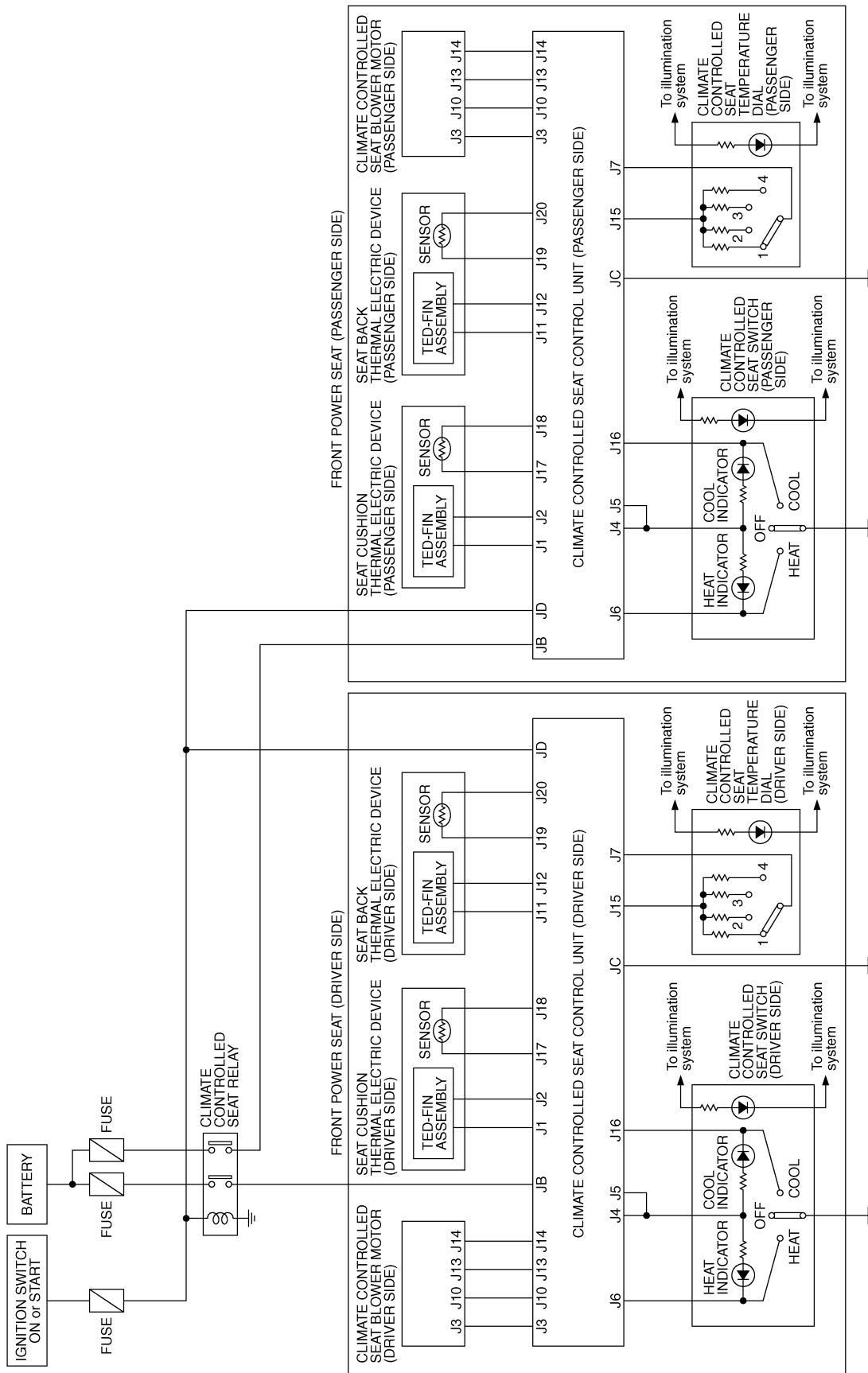

A
B
C
D
E
F
G
H
SE
J
K
L
M

TIWM0139E

CLIMATE CONTROLLED SEAT

EIS008MJ

Wiring Diagram—C/SEAT—

SE-C/SEAT-01

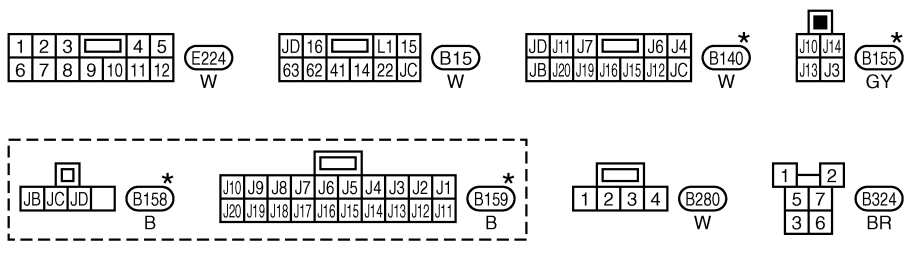
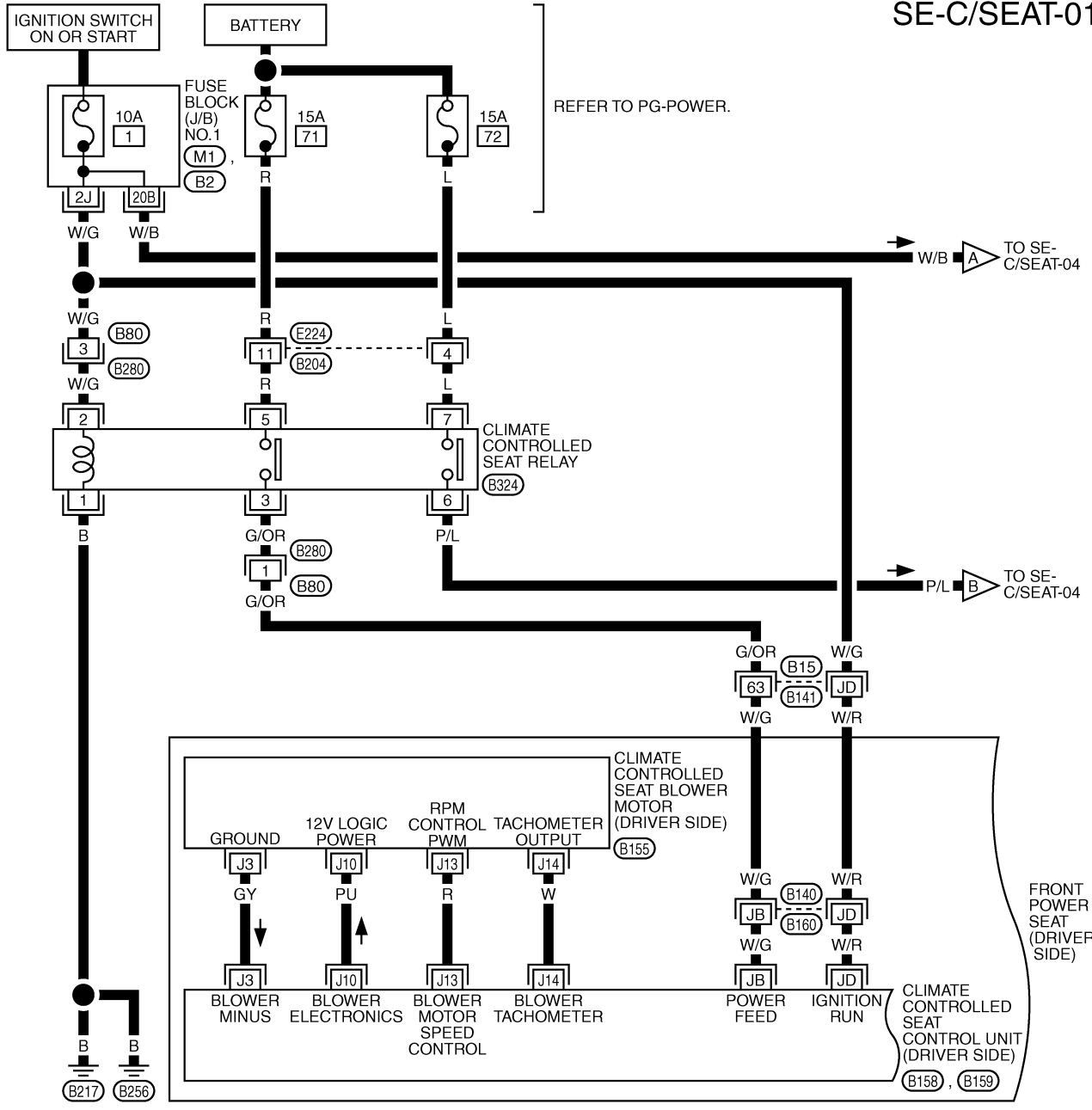

REFER TO THE FOLLOWING.
 (M1), (B2) - FUSE BLOCK-JUNCTION BOX (J/B) NO.1

*: THIS CONNECTOR IS NOT SHOWN IN "HARNESS LAYOUT", PG. SECTION.

TIWM0747E

CLIMATE CONTROLLED SEAT

SE-C/SEAT-02

A
B
C
D
E
F
G
H
SE
J
K
L
M

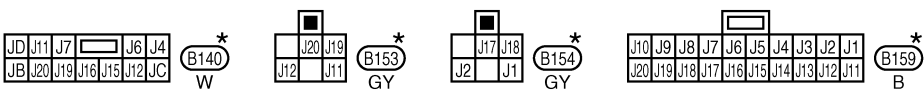
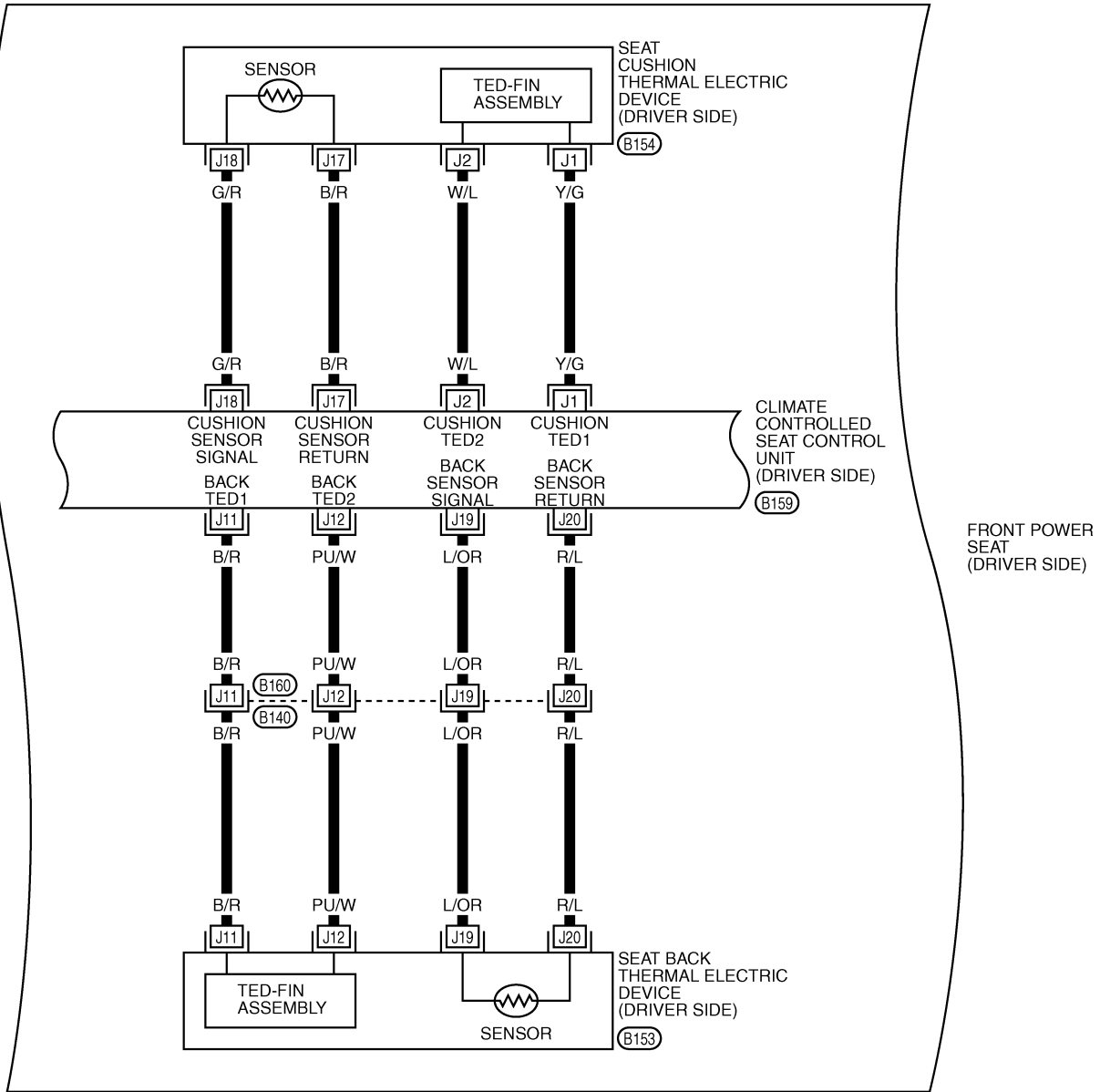

*: THIS CONNECTOR IS NOT SHOWN IN "HARNESS LAYOUT", PG SECTION.

TIWM0155E

CLIMATE CONTROLLED SEAT

SE-C/SEAT-03

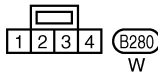
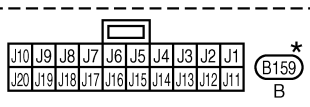
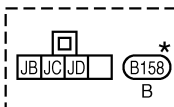
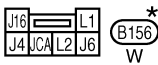
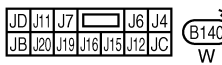
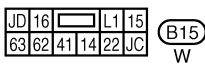
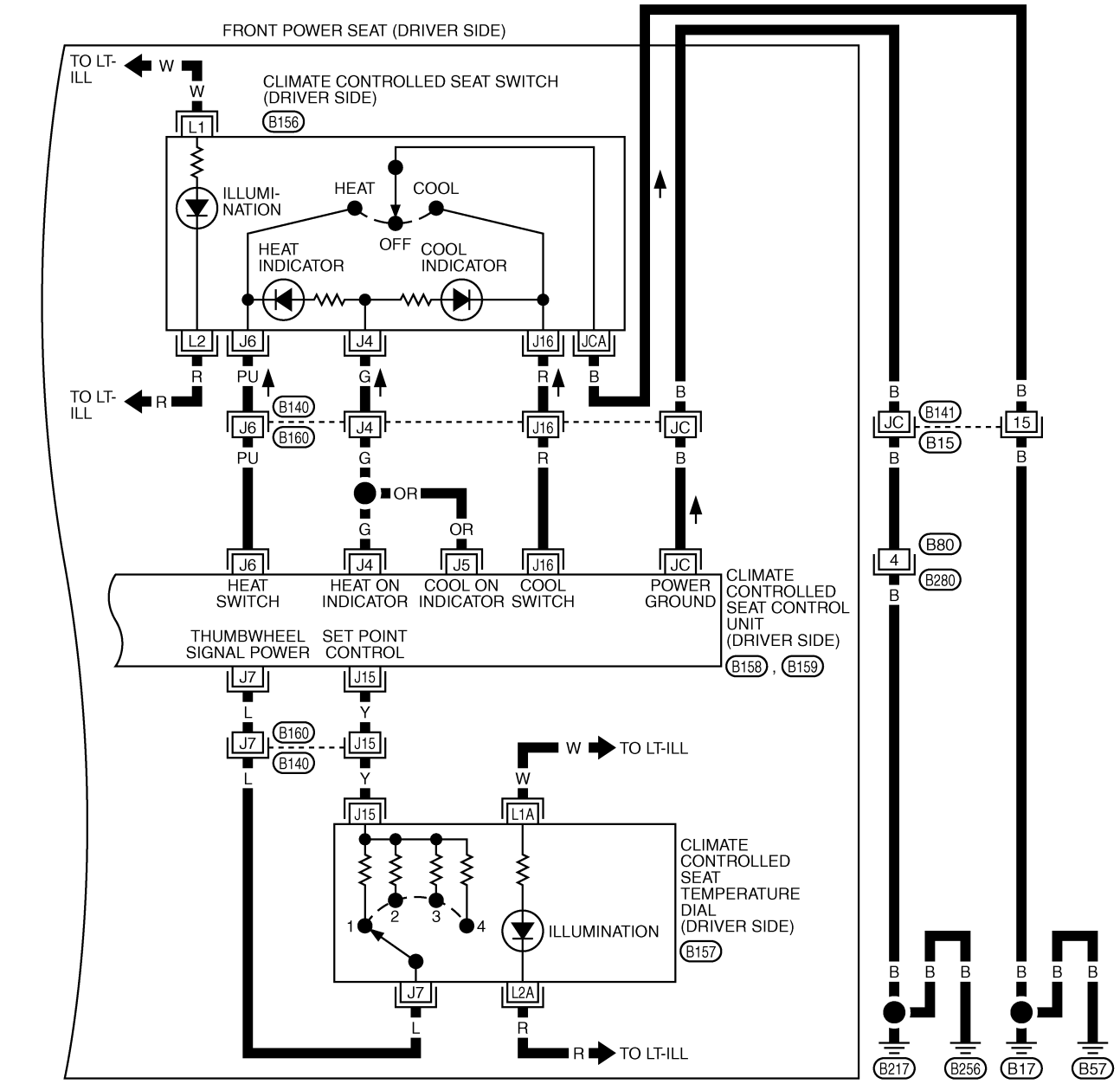

*: THIS CONNECTOR IS NOT SHOWN IN "HARNESS LAYOUT", PG SECTION.

T1WM0748E

CLIMATE CONTROLLED SEAT

SE-C/SEAT-04

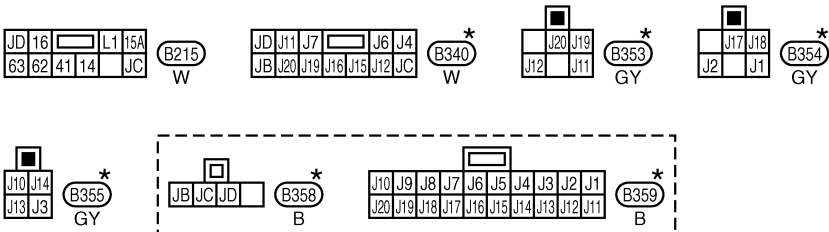
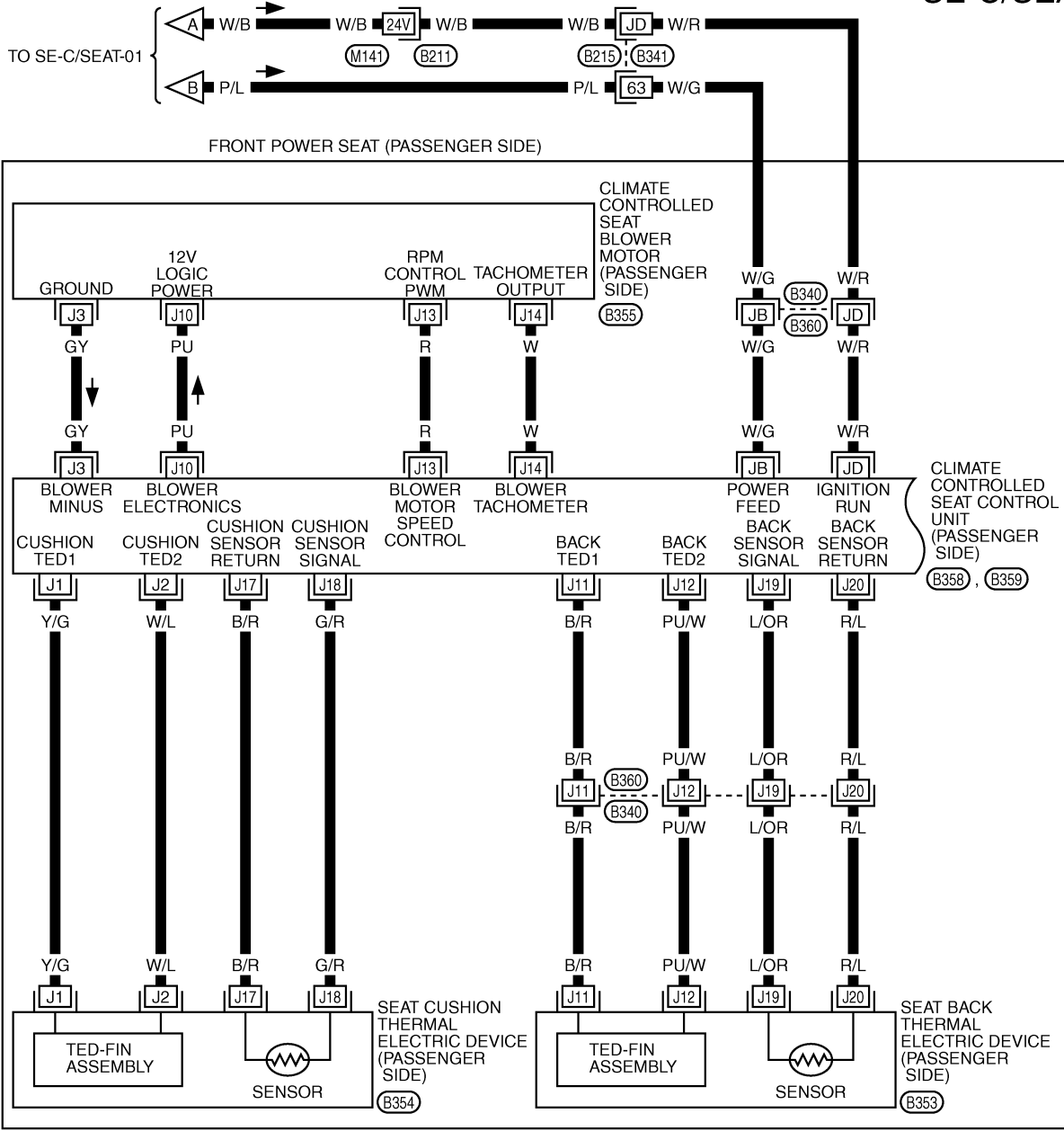

*: THIS CONNECTOR IS NOT SHOWN IN "HARNESS LAYOUT", PG SECTION.

REFER TO THE FOLLOWING.
 (B211) -SUPER MULTIPLE JUNCTION (SMJ)

TIWM0749E

CLIMATE CONTROLLED SEAT

SE-C/SEAT-05

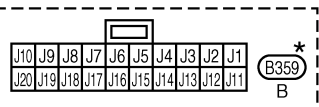
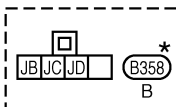
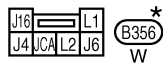
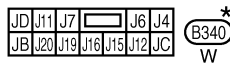
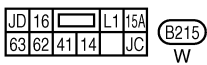
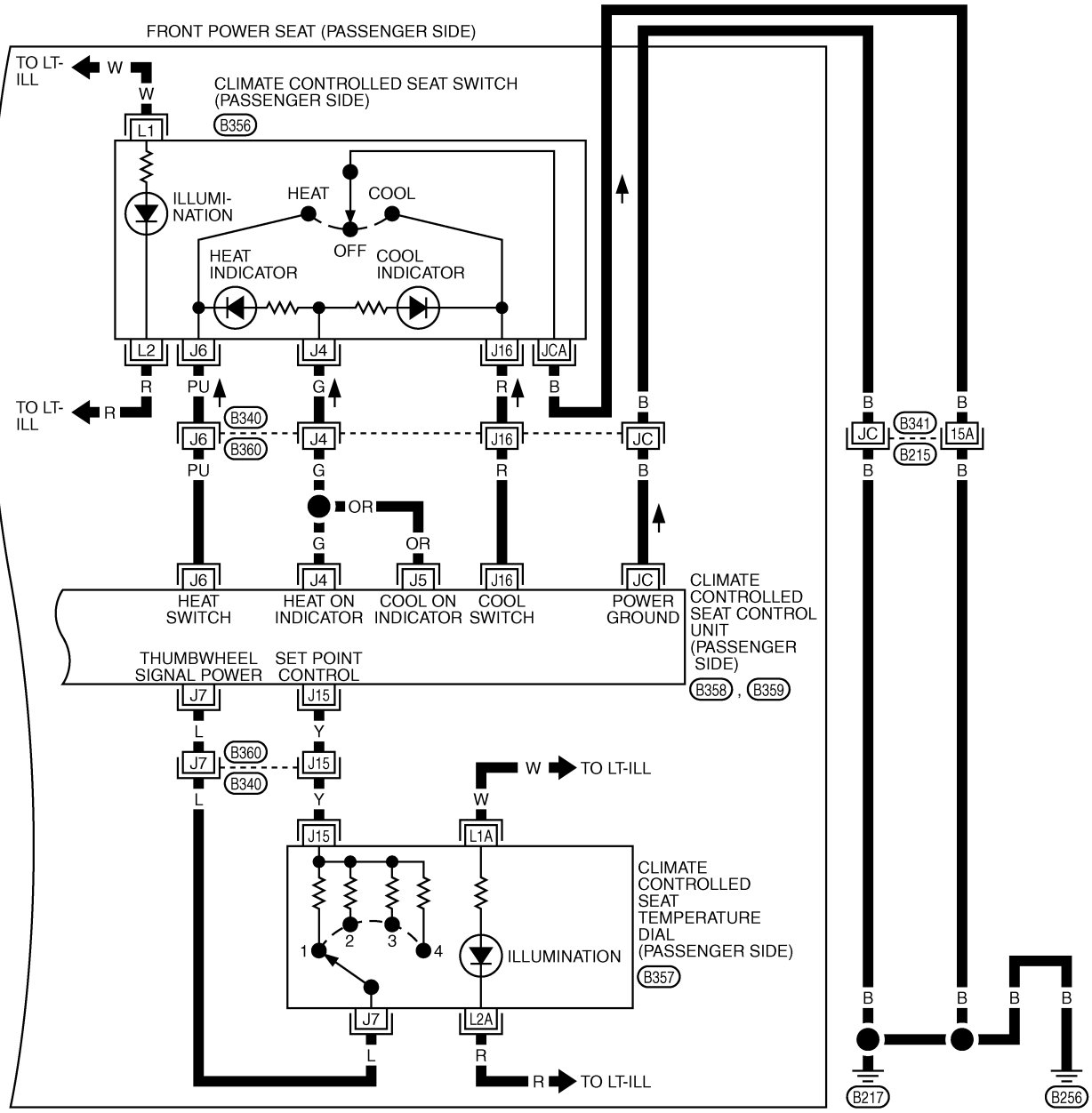

*: THIS CONNECTOR IS NOT SHOWN IN "HARNESS LAYOUT", PG SECTION.

T1WM0750E

CLIMATE CONTROLLED SEAT

Terminal and Reference Value For Climate Controlled Seat Control Unit

EIS008MK

TER-MINAL	WIRE COLOR	ITEM	CONDITION		VOLTAGE (V) (Approx)
JB	W/G	Ignition switch power supply	Ignition switch ON or START		Battery voltage
JC	B	Ground	—		0
JD	W/R	Ignition switch power supply	Ignition switch ON or START		Battery voltage
J 1	Y/G	Seat cushion thermal electric device power supply (HEAT)	Ignition switch ON or START	Climate controlled seat switch select "HEAT"	0 – Battery voltage
				Climate controlled seat switch select "OFF"	0
J 2	W/L	Seat cushion thermal electric device power supply (COOL)	Ignition switch ON or START	Climate controlled seat switch select "COOL"	0 – Battery voltage
				Climate controlled seat switch select "OFF"	0
J3	GY	Ground	—		0
J4	G	"HEAT" switch indicator signal	Ignition switch ON or START	Climate controlled seat switch select "HEAT"	Battery voltage
				Climate controlled seat switch select "OFF"	0
J5	OR	"COOL" switch indicator signal	Ignition switch ON or START	Climate controlled seat switch select "COOL"	Battery voltage
				Climate controlled seat switch select "OFF"	0
J6	PU	"HEAT" switch signal	Ignition switch ON or START	Climate controlled seat switch select "HEAT"	0
				Climate controlled seat switch OFF	Battery voltage
J7	L	Temperature dial power supply	Ignition switch ON or START	temperature dial 1 – 4	7.1 – 11.4
			Ignition switch OFF		0
J10	PU	Blower motor power supply	Ignition switch ON or START	Climate controlled seat switch select "HEAT" or "COOL" temperature dial 1 – 4	5.5 – Battery voltage
				Climate controlled seat switch select "OFF"	Battery voltage
			Ignition switch OFF		0
J 11	B/R	Seatback thermal electric device power supply (HEAT)	Ignition switch ON or START	Climate controlled seat switch select "HEAT"	0 – Battery voltage
				Climate controlled seat switch select "OFF"	0
J 12	PU/W	Seatback thermal electric device power supply (COOL)	Ignition switch ON or START	Climate controlled seat switch select "COOL"	0 – Battery voltage
				Climate controlled seat switch select "OFF"	0
J 13	R	Blower motor speed control signal	Ignition switch ON or START	Climate controlled seat switch select "HEAT" or "COOL" temperature dial 1 – 4	4.5 – 9.5
				Climate controlled seat switch OFF	0
J14	W	Blower motor tachometer signal	Ignition switch ON or START	Climate controlled seat switch select "HEAT" or "COOL"	5 – 7
				Climate controlled seat switch OFF	Battery voltage

CLIMATE CONTROLLED SEAT

TER-MINAL	WIRE COLOR	ITEM	CONDITION		VOLTAGE (V) (Approx)
J15	Y	Temperature dial signal	Ignition switch ON or START	temperature dial 1 – 4	0 – 5
			Ignition switch OFF		0
J16	R	“COOL” switch signal	Ignition switch ON or START	Climate controlled seat switch select “COOL”	0
				Climate controlled seat switch OFF	Battery voltage
J17	B/R	Seat cushion thermal electric device sensor ground	Ignition switch ON		0
J18	G/R	Seat cushion thermal electric device sensor signal	Ignition switch ON or START		0.5 – 4
			Ignition switch OFF		0
J19	L/OR	Seatback thermal electric device sensor signal	Ignition switch ON or START		0.5 – 4
			Ignition switch OFF		0
J20	R/L	Seatback thermal electric device sensor ground	Ignition switch ON		0

Work Flow

EIS008ML

1. Check the symptom and customer's requests.
2. Understand the outline of system. Refer to [SE-157, "System Description"](#) .
3. Perform the preliminary check. Refer to [SE-168, "Preliminary Check"](#) .
4. According to the trouble diagnosis chart, repair or replace the cause of the malfunction. Refer to [SE-169, "Trouble Diagnoses Symptom Chart"](#) .
5. Does climate controlled seat operate normally? YES: GO TO 6, NO: GO TO 4.
6. INSPECTION END.

Preliminary Check

EIS008MM

1. CHECK DUCT AND FILTER

Check the following.

- Is that there no foreign body in the blower motor filter.
- Is that there no foreign body in the duct.

OK or NG

- OK >> Preliminary check is OK.
 NG >> The foreign body is removed.

CLIMATE CONTROLLED SEAT

Trouble Diagnoses Symptom Chart

EIS008MN

NOTE:

Make sure other systems using the signal of the following systems operate normally.

Symptom	Diagnoses / service procedure	Refer to page
Climate controlled seat do not operate (Neither the driver' s side nor passenger's side operate).	1. Climate controlled seat relay power supply circuit inspection.	SE-170
All the driver side climate controlled seat do not operate (Passenger side operates).	1. Driver side climate controlled seat control unit power supply and ground circuit inspection.	SE-171
	2. Climate controlled seat temperature dial circuit inspection.	SE-177
	3. Climate controlled seat switch ground circuit inspection	SE-178
	4. Blower motor power supply circuit inspection.	SE-182
	5. Replace blower motor assembly.	—
All the passenger side climate controlled seat do not operate (Driver side operates)	1. Passenger side climate controlled seat control unit power supply and ground circuit inspection.	SE-172
	2. Climate controlled seat temperature dial circuit inspection.	SE-177
	3. Climate controlled seat switch ground circuit inspection	SE-178
	4. Blower motor power supply circuit inspection.	SE-182
	5. Replace blower motor assembly.	—
Blower motor speed cannot adjust.	1. Climate controlled temperature dial inspection.	SE-176
	2. Climate controlled seat control unit inspection.	SE-185
	3. Replace blower motor assembly.	—
The climate controlled seat dose not operates when the switch is done in "HEAT" (The wind rises when the switch is in "COOL" mode).	Climate controlled seat "HEAT" switch circuit inspection.	SE-174
The climate controlled seat dose not operates when the switch is done in "COOL" (The wind rises when the switch is in "HEAT" mode).	Climate controlled seat "COOL" switch circuit inspection.	SE-175
When the climate controlled seat switch is turned on, operation stops at nose (When the climate controlled seat switch is in "HEAT" or "COOL" mode after ignition switch is turned ON again, the motor operates).	1. Seat cushion thermal electric device sensor circuit inspection.	SE-180
	2. Seat cushion thermal electric device circuit inspection	SE-179
	3. Seat back thermal electric device sensor circuit inspection.	SE-182
	4. Seat back thermal electric device circuit inspection	SE-181
	5. Blower motor speed control circuit inspection.	SE-184
	6. Blower motor tachometer signal circuit inspection.	SE-184
	7. Replace Climate controlled seat control unit	—

NOTE:

- The climate controlled seat blower keep low speed for approximately 60 seconds turning the switch or the dial.
- The climate controlled seat system is downed when the temperature sensor set as the seat cushion and the seat back's thermal electric device machine detects 20 °C (68°F) or more of mutual differences of temperature.

CLIMATE CONTROLLED SEAT

EIS008MO

Climate Controlled Relay Power Supply Circuit Check

1. CHECK FUSE

Check 10A fuse [No. 1, located in fuse block (J/B)]

NOTE:

Refer to [SE-160, "Component Parts and Harness Connector Location"](#).

OK or NG

OK >> GO TO 2.

NG >> If fuse is blown, be sure to eliminate cause of malfunction before installing new fuse, refer to [PG-2, "POWER SUPPLY ROUTING"](#).

2. CHECK SEAT RELAY POWER SUPPLY CIRCUIT

1. Turn ignition switch OFF.
2. Disconnect climate controlled seat relay connector.
3. Turn ignition switch ON.
4. Check voltage between climate controlled seat relay harness connector B324 terminal 2 (W/G) and ground.

Con- nector	Terminal (Wire color)		Condition	Voltage (V)
	(+)	(-)		
B324	2 (W/G)	Ground	Turn ignition switch ON.	Battery voltage
			Turn ignition switch OFF.	0

OK or NG

OK >> GO TO 3.

NG >> Repair or replace harness between fuse block (J/B) and climate controlled seat relay.

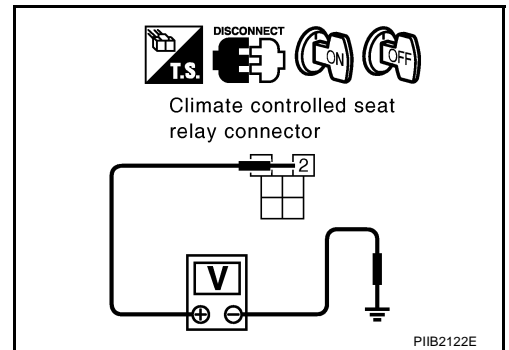

3. CHECK CLIMATE CONTROLLED SEAT RELAY

1. Turn ignition switch OFF.
2. Remove climate controlled seat relay.
3. Check continuity between terminals 3 and 5, 6 and 7.

Terminal	Terminal	Condition	Continuity
3	5	12V direct current supply between terminals 1 and 2	Yes
		No current supply	No
6	7	12V direct current supply between terminals 1 and 2	Yes
		No current supply	No

OK or NG

OK >> GO TO 4.

NG >> Replace climate controlled seat relay.

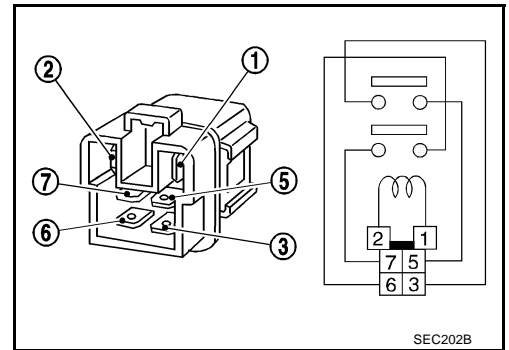

CLIMATE CONTROLLED SEAT

4. CHECK CLIMATE CONTROLLED SEAT CONTROL UNIT GROUND CIRCUIT

Check continuity between climate controlled seat relay connector B324 terminal 1 (B) and ground.

1 (B) – Ground : Continuity should exist

OK or NG

- OK >> Climate controlled seat relay power supply circuit check is OK.
- NG >> Repair or replace harness between climate controlled seat relay and ground.

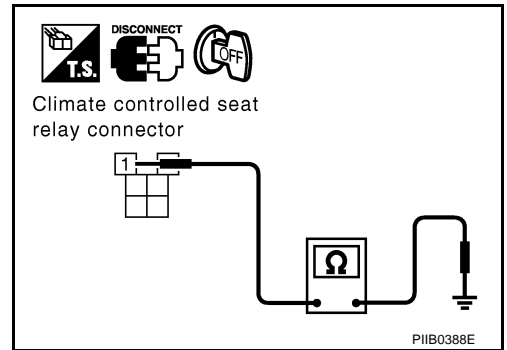

Driver Side Climate Controlled Seat Control Unit Power Supply and Ground Circuit Inspection

EIS008MP

1. CHECK FUSE

Check 15A fuse [No. 71, located in fuse, fusible link and relay unit]

NOTE:

Refer to [SE-160, "Component Parts and Harness Connector Location"](#) .

OK or NG

- OK >> GO TO 2.
- NG >> If fuse is blown, be sure to eliminate cause of malfunction before installing new fuse, refer to [PG-2, "POWER SUPPLY ROUTING"](#) .

2. CHECK CLIMATE CONTROLLED SEAT CONTROL UNIT POWER SUPPLY CIRCUIT 1

1. Turn ignition switch OFF.
2. Disconnect climate controlled seat relay.
3. Check voltage between climate controlled seat relay connector B324 terminal 5 (R) and ground.

5 (R) – Ground : Battery voltage

OK or NG

- OK >> GO TO 3.
- NG >> Repair or replace harness.

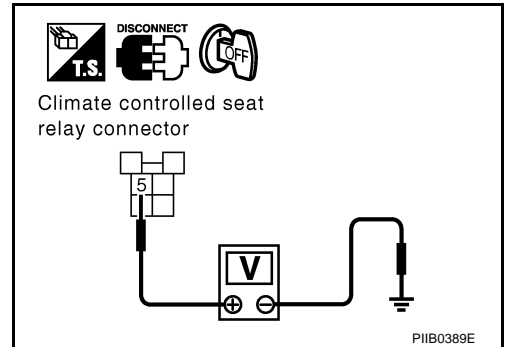

3. CHECK CLIMATE CONTROLLED SEAT RELAY

1. Remove climate controlled seat relay.
2. Check continuity between terminals 3 and 5.

Terminal	Condition	Continuity
3	12V direct current supply between terminals 1 and 2	YES
5	No current supply	NO

OK or NG

- OK >> GO TO 4.
- NG >> Replace climate controlled seat relay.

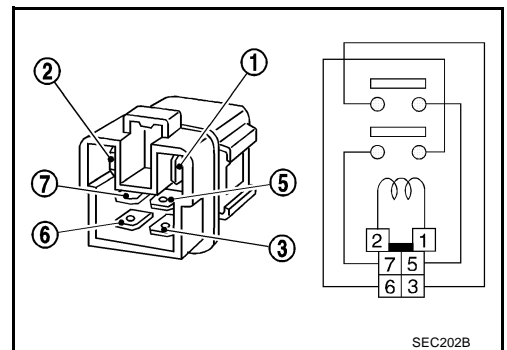

CLIMATE CONTROLLED SEAT

4. CHECK CLIMATE CONTROLLED SEAT CONTROL UNIT POWER SUPPLY CIRCUIT 2

1. Disconnect climate controlled seat control unit connector.
2. Turn ignition switch ON.
3. Check voltage between climate controlled seat control unit connector and ground.

Con- nector	Terminal (Wire color)		Condition	Voltage (V) (Approx)
	(+)	(-)		
B158	JB (W/G)	Ground	Turn ignition switch ON.	Battery voltage
			Turn ignition switch OFF.	0

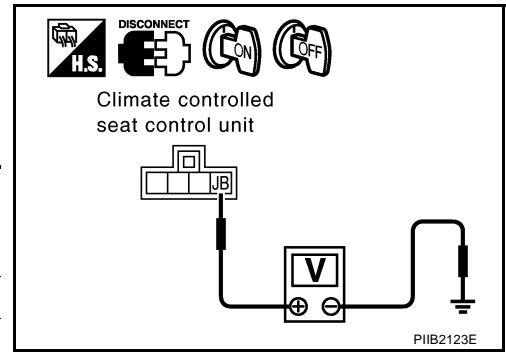

OK or NG

- OK >> GO TO 5.
NG >> Repair or replace harness.

5. CHECK CLIMATE CONTROLLED SEAT CONTROL UNIT POWER SUPPLY CIRCUIT

Check voltage between climate controlled seat control unit connector and ground.

Con- nector	Terminal (Wire color)		Condition	Voltage (V) (Approx)
	(+)	(-)		
B158	JD (W/R)	Ground	Turn ignition switch ON.	Battery voltage
			Turn ignition switch OFF.	0

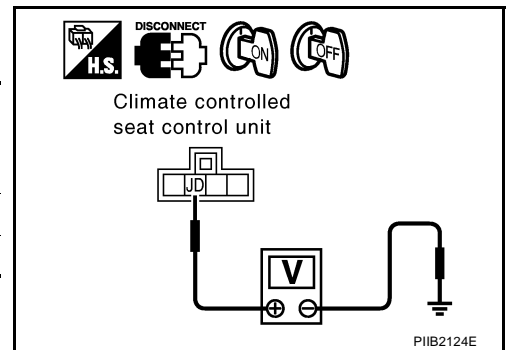

OK or NG

- OK >> GO TO 6.
NG >> Repair or replace harness.

6. CHECK CLIMATE CONTROLLED SEAT CONTROL UNIT GROUND CIRCUIT

1. Turn ignition switch OFF.
2. Check continuity between climate controlled seat control unit connector B158 terminal JC (B) and ground.

JC (B) – Ground : Continuity should exist

OK or NG

- OK >> Driver side climate controlled seat control unit power supply and ground circuit check is OK.
NG >> Repair or replace harness.

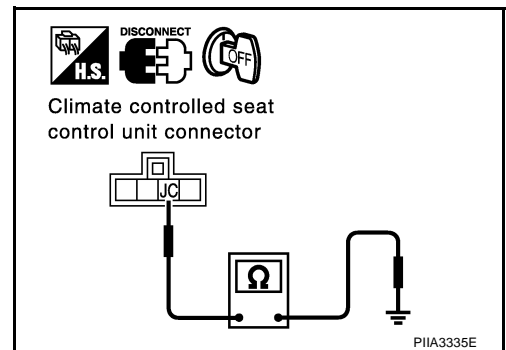

Passenger Side Climate Controlled Seat Control Unit Power Supply Circuit Inspection

EIS008MQ

1. CHECK FUSE

Check 10A fuse [No. 72, located in fuse, fusible link and relay unit]

NOTE:

Refer to [SE-160, "Component Parts and Harness Connector Location"](#) .

OK or NG

- OK >> GO TO 2.
NG >> If fuse is blown, be sure to eliminate cause of malfunction before installing new fuse, refer to [PG-2, "POWER SUPPLY ROUTING"](#) .

CLIMATE CONTROLLED SEAT

2. CHECK CLIMATE CONTROLLED SEAT CONTROL UNIT POWER SUPPLY CIRCUIT 1

1. Turn ignition switch OFF.
2. Check voltage between climate controlled seat relay connector B324 terminal 7 (L) and ground.

7 (L) – Ground : Battery voltage

OK or NG

- OK >> GO TO 3.
 NG >> Repair or replace harness.

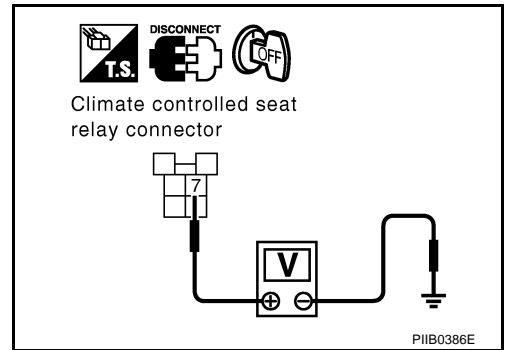

3. CHECK CLIMATE CONTROLLED SEAT RELAY

1. Remove climate controlled seat relay.
2. Check continuity between terminals 6 and 7.

Terminal	Condition	Continuity
6	12V direct current supply between terminals 1 and 2	YES
7	No current supply	NO

OK or NG

- OK >> GO TO 4.
 NG >> Replace air conditioning seat relay.

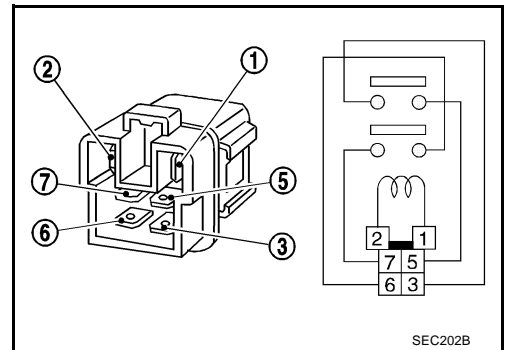

4. CHECK CLIMATE CONTROLLED SEAT CONTROL UNIT POWER SUPPLY CIRCUIT 2

1. Disconnect climate controlled seat control unit connector.
2. Turn ignition switch ON.
3. Check voltage between climate controlled seat control unit connector and ground.

Con- nector	Terminal (Wire color)		Condition	Voltage (V) (Approx)
	(+)	(-)		
B158	JB (W/G)	Ground	Turn ignition switch ON.	Battery voltage
			Turn ignition switch OFF.	0

OK or NG

- OK >> GO TO 5.
 NG >> Repair or replace harness.

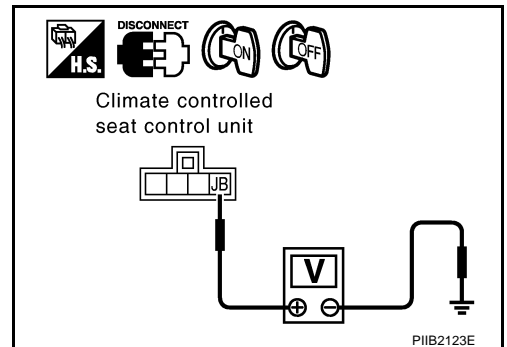

CLIMATE CONTROLLED SEAT

5. CHECK CLIMATE CONTROLLED SEAT CONTROL UNIT POWER SUPPLY CIRCUIT

Check voltage between climate controlled seat control unit connector and ground.

Connector	Terminal (Wire color)		Condition	Voltage (V) (Approx)
	(+)	(-)		
B158	JD (W/R)	Ground	Turn ignition switch ON.	Battery voltage
			Turn ignition switch OFF.	0

OK or NG

OK >> GO TO 6.

NG >> Repair or replace harness.

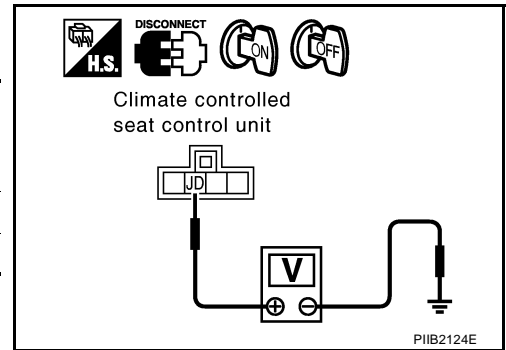

6. CHECK CLIMATE CONTROLLED SEAT CONTROL UNIT GROUND CIRCUIT

1. Turn ignition switch OFF.
2. Check continuity between climate controlled seat control unit connector B158 (Driver side), B358 (passenger side) terminal JC (B) and ground.

JC (B) – ground :Continuity should exist

OK or NG

OK >> Passenger side climate controlled seat unit power supply circuit and ground check is OK.

NG >> Repair or replace harness.

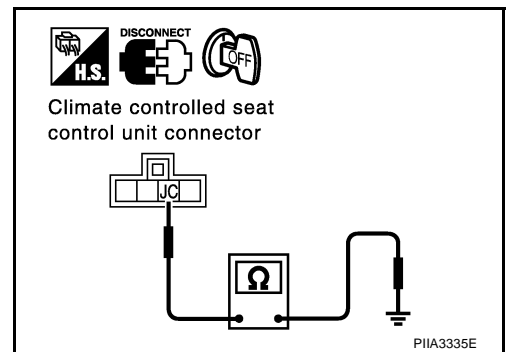

Climate Controlled Seat “HEAT” Switch Circuit Inspection

EIS008MR

1. CHECK CLIMATE CONTROLLED SEAT HEAT SWITCH HARNESS CIRCUIT

1. Turn ignition switch OFF.
2. Disconnect climate controlled seat control unit and climate controlled seat switch connector.
3. Check continuity between climate controlled seat control unit connector B159 (driver side), B359 (passenger side) terminal J6 (PU) and climate controlled seat switch connector B156 (driver side), B356 (passenger side) terminal J6 (PU).

J6 (PU) – J6 (PU) :Continuity should exist.

4. Check continuity between climate controlled seat control unit connector B159 (driver side), B359 (passenger side) terminal J6 (PU) and ground.

J6 (PU) – Ground :Continuity should not exist.

OK or NG

OK >> GO TO 2.

NG >> Repair or replace harness.

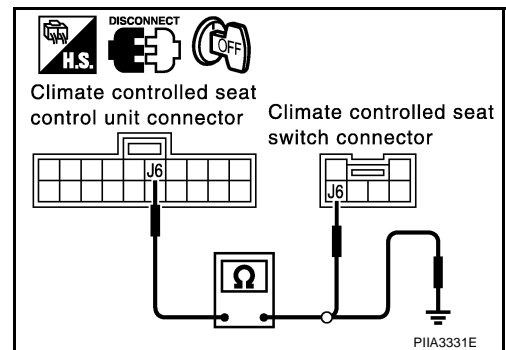

CLIMATE CONTROLLED SEAT

2. CHECK CLIMATE CONTROLLED SEAT HEAT SWITCH POWER SUPPLY CIRCUIT

1. Connect climate controlled seat control unit connector and climate controlled seat switch.
2. Turn ignition switch ON.
3. Turn climate controlled seat switch "HEAT".
4. Check voltage between climate controlled seat control unit connector and body ground.

Connector	Terminal (Wire color)		Condition	Voltage (V) (Approx.)
	(+)	(-)		
B159 (Driver side), B359 (Passenger side)	J6 (PU)	Ground	Turn climate controlled seat switch "HEAT".	0
			Climate controlled seat switch OFF.	Battery voltage

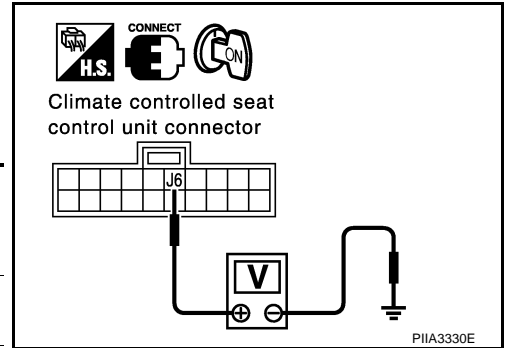

OK or NG

- OK >> Replace climate controlled seat control unit.
 NG >> GO TO 3.

3. CHECK CLIMATE CONTROLLED SEAT HEAT SWITCH

1. Turn ignition switch OFF.
2. Disconnect climate controlled seat switch connector.
3. Check continuity between climate controlled seat switch as follows.

Terminal		Condition	Continuity
J6	JCA	Climate controlled seat switch HEAT position.	YES
		Climate controlled seat switch OFF.	NO

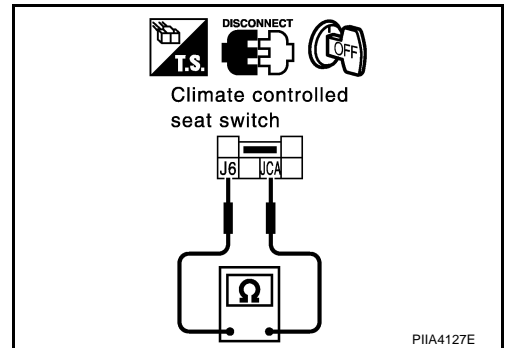

OK or NG

- OK >> Check the condition of the harness and the connector.
 NG >> Replace climate controlled seat switch.

Climate Controlled Seat "COOL" Switch Circuit Inspection

EIS008MS

1. CHECK CLIMATE CONTROLLED SEAT COOL SWITCH HARNESS CIRCUIT

1. Turn ignition switch OFF.
2. Disconnect climate controlled seat control unit and climate controlled seat switch connector.
3. Check continuity between climate controlled seat control unit connector B159 (driver side), B359 (passenger side) terminal J16 (R) and climate controlled seat switch connector B156 (driver side), B356 (passenger side) terminal J16 (R).

J16 (R) – J16 (R) :Continuity should exist.

4. Check continuity between climate controlled seat control unit connector B159 (driver side), B359 (passenger side) terminal J16 (R) and ground.

J16 (R) – Ground :Continuity should not exist.

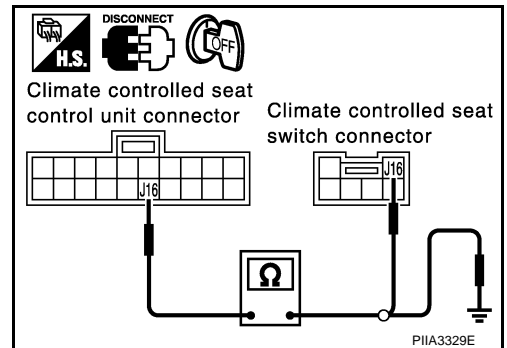

OK or NG

- OK >> GO TO 2.
 NG >> Repair or replace harness.

CLIMATE CONTROLLED SEAT

2. CHECK CLIMATE CONTROLLED SEAT COOL SWITCH POWER SUPPLY CIRCUIT

1. Connect climate controlled seat control unit connector and climate controlled seat switch.
2. Turn ignition switch ON.
3. Turn climate controlled seat switch COOL.
4. Check voltage between climate controlled seat control unit connector and body ground.

Connector	Terminal (Wire color)		Condition	Voltage (V) (Approx.)
	(+)	(-)		
B159 (Driver side), B359 (Passenger side)	J16 (R)	Ground	Turn climate controlled seat switch COOL.	0
			Climate controlled seat switch OFF.	Battery voltage

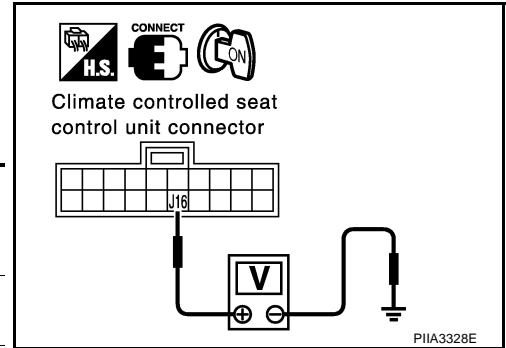

OK or NG

- OK >> Replace climate controlled seat control unit.
 NG >> GO TO 3.

3. CHECK CLIMATE CONTROLLED SEAT COOL SWITCH

1. Turn ignition switch OFF.
2. Disconnect climate controlled seat switch connector.
3. Check continuity between climate controlled seat switch as follows.

Terminal		Condition	Continuity
J16	JCA	Climate controlled seat switch COOL position.	Yes
		Climate controlled seat switch OFF.	No

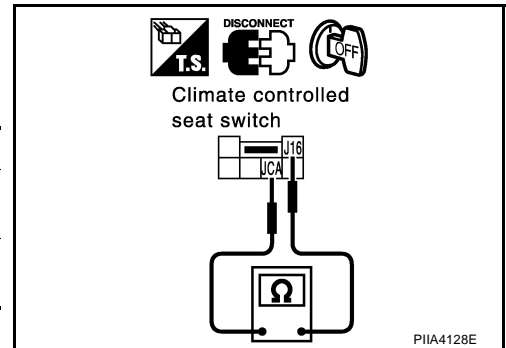

OK or NG

- OK >> Check the condition of the harness and the connector.
 NG >> Replace climate controlled seat switch.

Climate Controlled Seat Temperature Dial Inspection

EIS008MT

1. CHECK CLIMATE CONTROLLED SEAT TEMPERATURE DIAL

1. Turn ignition switch OFF.
2. Disconnect climate controlled seat temperature dial connector.
3. Check continuity between climate controlled seat temperature dial as follows.

Terminal		Condition	Continuity(Ω) (Approx)
J7	J15	Temperature dial 1st.	2370
		Temperature dial 2nd.	1100
		Temperature dial 3rd.	619
		Temperature dial 4th.	237

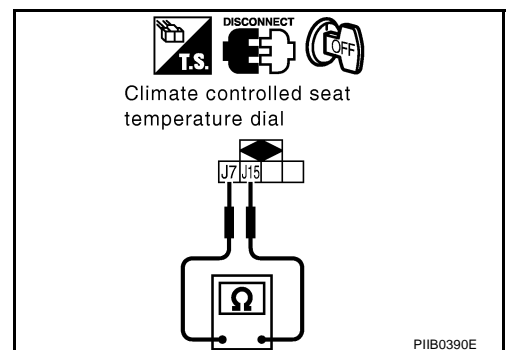

OK or NG

- OK >> Climate controlled seat temperature dial check is OK.
 NG >> Replace climate controlled seat temperature dial.

CLIMATE CONTROLLED SEAT

Climate Controlled Seat Temperature Dial Circuit Inspection

EIS008MU

1. CHECK CLIMATE CONTROLLED SEAT TEMPERATURE DIAL HARNESS

1. Turn ignition switch OFF.
2. Disconnect climate controlled seat control unit connector and climate controlled seat temperature dial connector.
3. Check continuity between climate controlled seat control unit connector B159 (driver side), B359 (passenger side) terminal J7 (L), J15 (Y) and climate controlled seat temperature dial connector B157 (driver side), B357 (passenger side) terminal J7 (L), J15 (Y).

J7 (L) – J7 (L) : Continuity should exist

J15 (Y) – J15 (Y) : Continuity should exist

4. Check continuity between climate controlled seat control unit connector B159 (driver side), B359 (passenger side) terminal J7 (L), J15 (Y) and ground.

J7 (L) – Ground : Continuity should not exist

J15 (Y) – Ground : Continuity should not exist

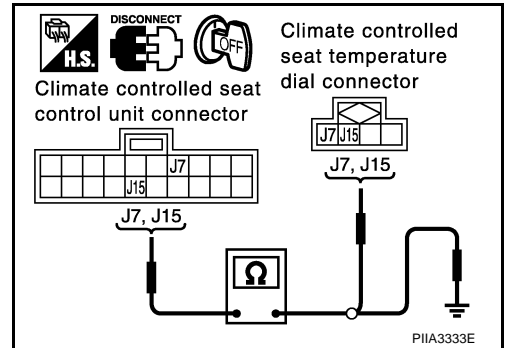

OK or NG

OK >> GO TO 2.

NG >> Repair or replace harness.

2. CHECK CLIMATE CONTROLLED SEAT TEMPERATURE DIAL POWER SUPPLY CIRCUIT

1. Connect climate controlled seat control unit connector and climate controlled seat temperature dial connector.
2. Turn ignition switch ON.
3. Check voltage between climate controlled seat control unit connector and ground.

Connector	Terminal (Wire color)		Condition	Voltage (V)
	(+)	(-)		
B159 (Driver side), B359 (Passenger side)	J7 (L)	Ground	temperature dial 1 – 4	7.1 – 11.4
			Turn ignition switch OFF.	0

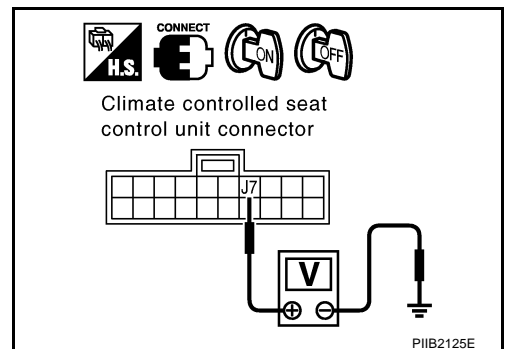

OK or NG

OK >> Climate controlled seat temperature dial circuit check is OK.

NG >> When turn ignition ON and temperature dial adjust, check the following

- When voltage is approx 12V, GO TO 3
- When voltage is approx 0V, Replace climate controlled seat control unit.

CLIMATE CONTROLLED SEAT

3. CHECK CLIMATE CONTROLLED SEAT TEMPERATURE DIAL

1. Turn ignition switch OFF.
2. Disconnect climate controlled seat temperature dial connector.
3. Check continuity between climate controlled seat temperature dial as follows.

Terminal		Condition	Continuity(Ω) (Approx)
J7	J15	Temperature dial 1st.	2370
		Temperature dial 2nd.	1100
		Temperature dial 3rd.	619
		Temperature dial 4th.	237

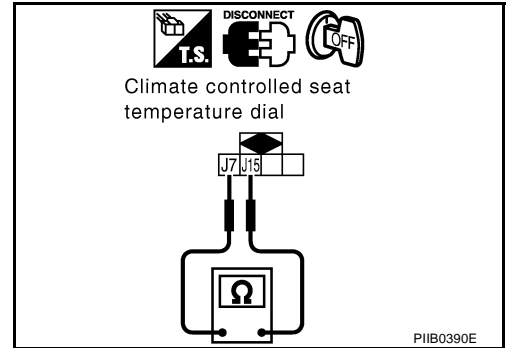

OK or NG

- OK >> Replace climate controlled seat control unit.
 NG >> Replace climate controlled seat temperature dial.

Climate Controlled Seat Switch Ground Circuit Inspection

EIS008MV

1. CHECK CLIMATE CONTROLLED SEAT SWITCH

1. Turn ignition switch OFF.
2. Disconnect climate controlled seat switch connector.
3. Check continuity between climate controlled seat switch as follows.

Terminal		Condition	Continuity
J6	JCA	Climate controlled seat switch HEAT position.	YES
		Climate controlled seat switch OFF.	NO
J16	JCA	Climate controlled seat switch COOL position.	YES
		Climate controlled seat switch OFF.	NO

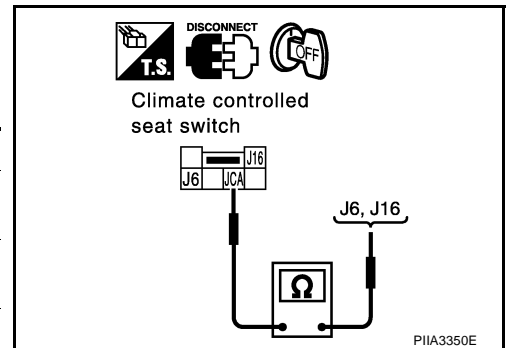

OK or NG

- OK >> GO TO 2.
 NG >> Replace climate controlled seat switch.

2. CHECK CLIMATE CONTROLLED SEAT SWITCH GROUND CIRCUIT

Check continuity between climate controlled seat switch connector B156 (driver side), B356 (passenger side) terminal JCA (B).

JCA (B) – Ground :Continuity should exist.

OK or NG

- OK >> Climate controlled seat control circuit check is OK.
 NG >> Repair or replace harness.

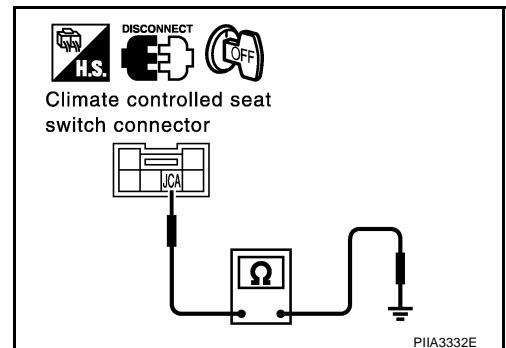

CLIMATE CONTROLLED SEAT

Seat Cushion Thermal Electric Device Circuit Inspection

EIS008MW

1. CHECK SEAT CUSHION THERMAL ELECTRIC DEVICE HARNESS

1. Turn ignition switch OFF.
2. Disconnect climate controlled seat control unit connector and seat cushion thermal electric device connector.
3. Check continuity between climate controlled seat control unit connector B159 (driver side), B359 (passenger side) terminal J1 (Y/G), J2 (W/L) and climate controlled seat temperature dial connector B154 (driver side), B354 (passenger side) terminal J1 (Y/G), J2 (W/L).

J1 (Y/G) – J1 (Y/G) : Continuity should exist

J2 (W/L) – J2 (W/L) : Continuity should exist

4. Check continuity between climate controlled seat control unit connector B159 (driver side), B359 (passenger side) terminal J1 (Y/G), J2 (W/L) and ground.

J1 (Y/G) – Ground : Continuity should not exist

J2 (W/L) – Ground : Continuity should not exist

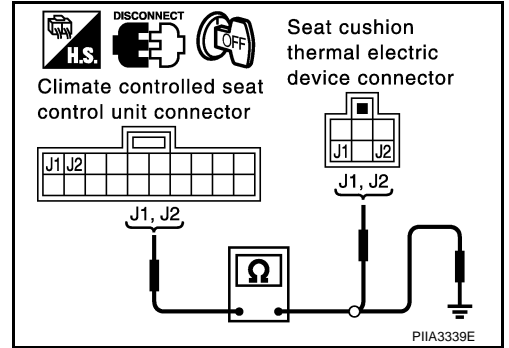

OK or NG

OK >> GO TO 2.

NG >> Repair or replace harness.

2. CHECK SEAT CUSHION THERMAL ELECTRIC DEVICE POWER SUPPLY CIRCUIT

1. Connect climate controlled seat control unit connector.
2. Check voltage between climate controlled seat control unit connector and ground.

Connector	Terminal (Wire color)		Condition	Voltage (V) (Approx)
	(+)	(-)		
B159 (Driver side), B359 (Passenger side)	J1 (Y/G)	Ground	Turn ignition switch ON, climate controlled seat switch turn "HEAT".	0 – Battery voltage
			Turn ignition switch OFF.	0
	J2 (WL)		Turn ignition switch ON, climate controlled seat switch turn "COOL".	0 – Battery voltage
			Turn ignition switch OFF.	0

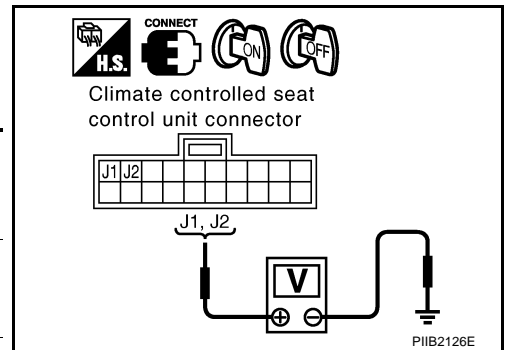

OK or NG

OK >> Seat cushion Thelma electric device circuit check is OK.

NG >> Replace seat cushion thermal electric device.

CLIMATE CONTROLLED SEAT

Seat Cushion Thermal Electric Device Sensor Circuit Inspection

EIS008MX

1. CHECK SEAT CUSHION THERMAL ELECTRIC DEVICE HARNESS

1. Turn ignition switch OFF.
2. Disconnect climate controlled seat control unit connector and seat cushion thermal electric device connector.
3. Check continuity between climate controlled seat control unit connector B159 (driver side), B359 (passenger side) terminal J17 (B/R), J18 (G/R) and climate controlled seat temperature dial connector B154 (driver side), B354 (passenger side) terminal J17 (B/R), J18 (G/R).

J17 (B/R) – J17 (B/R) : Continuity should exist

J18 (G/R) – J18 (G/R) : Continuity should exist

4. Check continuity between climate controlled seat control unit connector B159 (driver side), B359 (passenger side) terminal J17 (B/R), J18 (G/R) and ground.

J17 (B/R) – Ground : Continuity should not exist

J18 (G/R) – Ground : Continuity should not exist

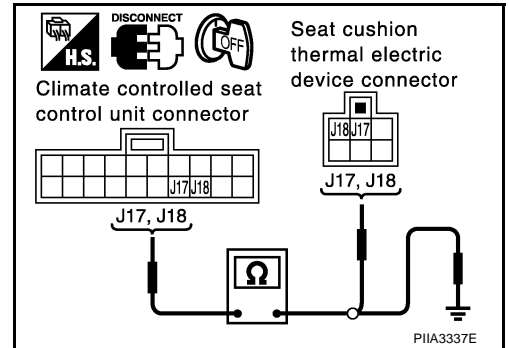

OK or NG

OK >> GO TO 2.

NG >> Repair or replace harness.

2. CHECK SEAT CUSHION THERMAL ELECTRIC DEVICE SENSOR

1. Connect climate controlled seat control unit connector and seat cushion thermal electric device connector.
2. Turn ignition switch ON.
3. Check voltage between seat cushion thermal electric device connector B154 (driver side), B354 (passenger side) terminal J18 (G/R) and body ground.

J18 (G/R) – Ground : 0.5V – 4V (Approx.)

OK or NG

OK >> Seat cushion thermal electric device sensor circuit inspection is OK.

NG >> Replace seat cushion thermal electric device.

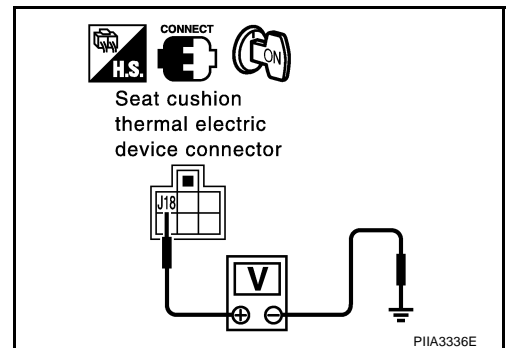

CLIMATE CONTROLLED SEAT

Seat Back Thermal Electric Device Circuit Inspection

EIS008MY

1. CHECK SEATBACK THERMAL ELECTRIC DEVICE HARNESS

1. Turn ignition switch OFF.
2. Disconnect climate controlled seat control unit connector and seatback thermal electric device connector.
3. Check continuity between climate controlled seat control unit connector B159 (driver side), B359 (passenger side) terminal J11 (B/R), J12 (PU/W) and seatback thermal electric device connector B153 (driver side), B353 (passenger side) terminal J11 (B/R), J12 (PU/W).

J11 (B/R) – J11 (B/R) : Continuity should exist

J12 (PU/W) – J12 (PU/W) : Continuity should exist

4. Check continuity between climate controlled seat control unit connector B159 (driver side), B359 (passenger side) terminal J11 (B/R), J12 (PU/W) and ground.

J11 (B/R) – Ground : Continuity should not exist

J12 (PU/W) – Ground : Continuity should not exist

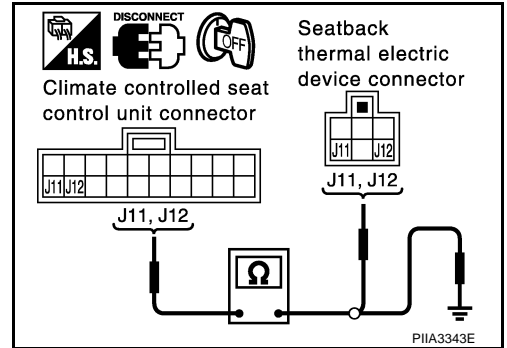

OK or NG

OK >> GO TO 2.

NG >> Repair or replace harness.

2. CHECK SEATBACK THERMAL ELECTRIC DEVICE POWER SUPPLY CIRCUIT

1. Connect climate controlled seat control unit connector and seatback thermal electric device connector.
2. Check voltage between climate controlled seat control unit connector and ground.

Connector	Terminal (Wire color)		Condition	Voltage (V) (Approx)
	(+)	(-)		
B159 (Driver side), B359 (Passenger side)	J11 (B/R)	Ground	Turn ignition switch ON, climate controlled seat switch turn "HEAT".	0 – Battery voltage
			Turn ignition switch OFF.	0
	J12 (PU/W)		Turn ignition switch ON, climate controlled seat switch turn "COOL".	0 – Battery voltage
			Turn ignition switch OFF.	0

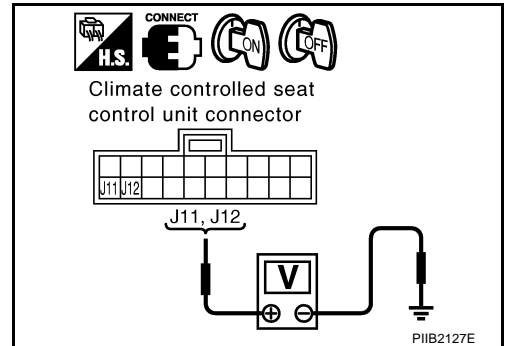

OK or NG

OK >> Seatback thermal electric device circuit check is OK.

NG >> Replace seat cushion thermal electric device.

CLIMATE CONTROLLED SEAT

Seatback Thermal Electric Device Sensor Circuit Inspection

EIS008MZ

1. CHECK SEATBACK THERMAL ELECTRIC DEVICE HARNESS

1. Turn ignition switch OFF.
2. Disconnect climate controlled seat control unit connector and seatback thermal electric device connector.
3. Check continuity between climate controlled seat control unit connector B159 (driver side), B359 (passenger side) terminal J19 (L/OR), J20 (R/L) and seatback thermal electric device connector B153 (driver side), B353 (passenger side) terminal J19 (L/OR), J20 (R/L).

J19 (L/OR) – J19 (L/OR) : Continuity should exist

J20 (R/L) – J20 (R/L) : Continuity should exist

4. Check continuity between climate controlled seat control unit connector B159 (driver side), B359 (passenger side) terminal J19 (L/OR), J20 (R/L) and ground.

J19 (L/OR) – Ground : Continuity should not exist

J20 (R/L) – Ground : Continuity should not exist

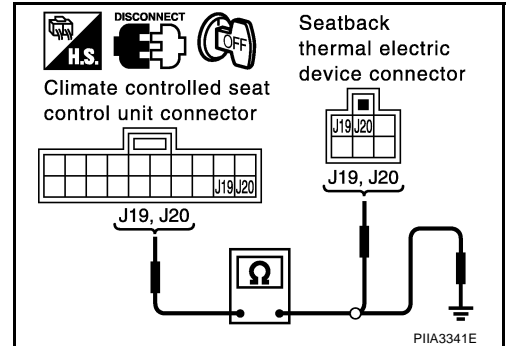

OK or NG

OK >> GO TO 2.

NG >> Repair or replace harness.

2. CHECK SEAT CUSHION THERMAL ELECTRIC DEVICE SENSOR

1. Connect climate controlled seat control unit connector and seatback thermal electric device connector.
2. Turn ignition switch ON.
3. Check voltage between seat cushion thermal electric device connector B153 (driver side), B353 (passenger side) terminal J19 (L/OR) and body ground.

J19 (L/OR) – Ground : 0.5V – 4V (Approx)

OK or NG

OK >> Seatback thermal electric device sensor circuit inspection is OK.

NG >> Replace seatback thermal electric device.

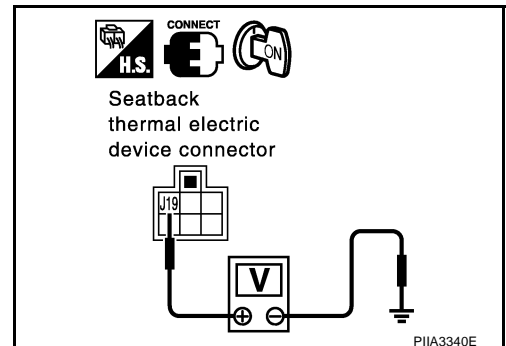

Blower Motor Power Supply Circuit Inspection

EIS008NO

1. CHECK BLOWER MOTOR HARNESS

1. Turn ignition switch OFF.
2. Disconnect climate controlled seat control unit and blower motor connector.
3. Check continuity between climate controlled seat control unit connector B159 (driver side), B359 (passenger side) terminal J10 (PU) and blower motor connector B155 (driver side), B355 (passenger side) terminal J10 (PU).

J10 (PU) – J10 (PU) : Continuity should exist

4. Check continuity between climate controlled seat control unit connector B159 (driver side), B359 (passenger side) terminal J10 (PU) and ground.

J10 (PU) – Ground : Continuity should not exist

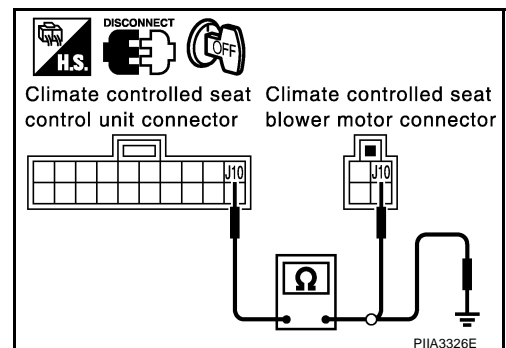

OK or NG

OK >> GO TO 2.

NG >> Repair or replace harness.

CLIMATE CONTROLLED SEAT

2. CHECK BLOWER MOTOR POWER SUPPLY CIRCUIT

1. Connect climate controlled seat control unit connector and blower motor connector.
2. Check voltage between climate controlled seat control unit connector and ground.

Connector	Terminal (Wire color)		Condition	Voltage (V) (Approx)
	(+)	(-)		
B159 (Driver side), B359 (Passenger side)	J10 (PU)	Ground	Turn ignition switch ON. Climate controlled seat switch "HEAT" or "COOL".	5.5 – Battery voltage
			Turn ignition switch OFF.	0

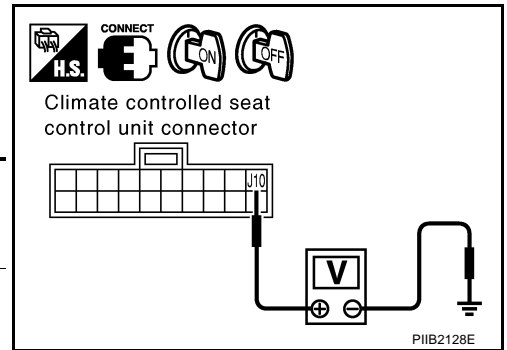

OK or NG

- OK >> GO TO 3.
 NG >> Replace climate controlled seat control unit.

3. CHECK BLOWER MOTOR GROUND HARNESS

1. Turn ignition switch OFF.
2. Disconnect climate controlled seat control unit connector and blower motor connector.
3. Check continuity between climate controlled seat control unit connector B159 (driver side), B359 (passenger side) terminal J 3 (GY) and blower motor connector B155 (driver side), B355 (passenger side) terminal J 3 (GY).

J3 (GY) – J3 (GY) : Continuity should exist

4. Check continuity between climate controlled seat control unit connector B159 (driver side), B359 (passenger side) terminal J3 (GY) and ground.

J3 (GY) – Ground : Continuity should not exist

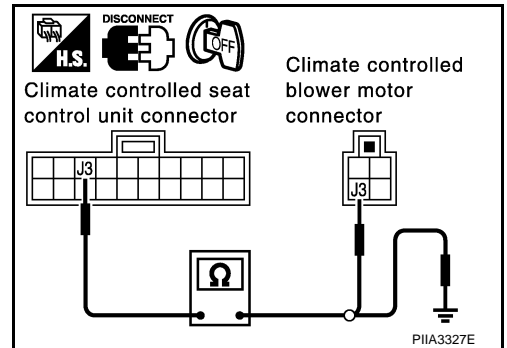

OK or NG

- OK >> GO TO 4.
 NG >> Repair or replace harness.

4. CHECK BLOWER MOTOR GROUND HARNESS

1. Connect climate controlled seat control unit connector.
2. Check continuity between climate controlled seat control unit connector B159 (driver side), B359 (passenger side) terminal J 3 (GY) and climate controlled seat control unit connector B158 (driver side), B358 (passenger side) terminal JC (B).

J3 (GY) – JC (B) :Continuity should exist

OK or NG

- OK >> Blower motor circuit check is OK.
 NG >> Replace climate controlled seat control unit.

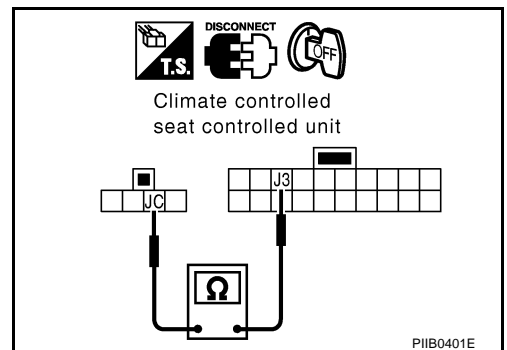

CLIMATE CONTROLLED SEAT

EIS008N1

Blower Motor Speed Control Circuit Inspection

1. CHECK BLOWER MOTOR SPEED CONTROL SIGNAL CIRCUIT

Check voltage between climate controlled seat control unit connector and ground.

Connector	Terminal (Wire color)		Condition	Voltage (V) (Approx)
	(+)	(-)		
B159 (Driver side), B359 (Passenger side)	J13 (R)	Ground	Turn ignition switch ON. Climate controlled seat switch "HEAT" or "COOL".	4.5 – 9.5
			Turn ignition switch OFF.	0

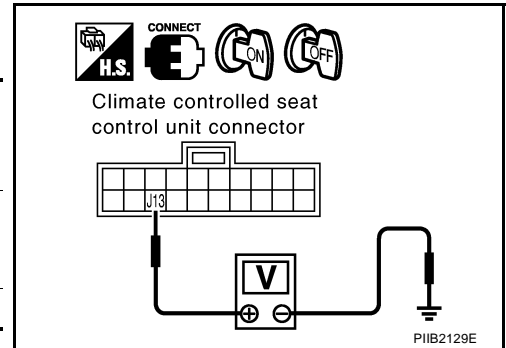

OK or NG

- OK >> GO TO 2.
- NG >> Replace climate controlled seat control unit.

2. CHECK BLOWER MOTOR HARNESS

1. Turn ignition switch OFF.
2. Disconnect climate controlled seat control unit connector and blower motor connector.
3. Check continuity between climate controlled seat control unit connector B159 (driver side), B359 (passenger side) terminal J13 (R) and blower motor connector B155 (driver side), B355 (passenger side) terminal J13 (R).

J13 (R) – J13 (R) : Continuity should exist

4. Check continuity between climate controlled seat control unit connector B159 (driver side), B359 (passenger side) terminal J13 (R) and ground.

J13 (R) – Ground : Continuity should not exist

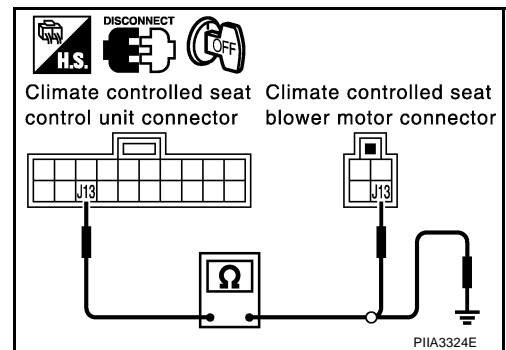

OK or NG

- OK >> Blower motor control circuit check is OK.
- NG >> Repair or replace harness.

Blower Motor Tachometer Signal Circuit Inspection

EIS008N2

1. CHECK BLOWER MOTOR TACHOMETER SIGNAL CIRCUIT

1. Connect climate controlled seat control unit connector and blower motor connector.
2. Turn ignition switch ON.
3. Check voltage between climate controlled seat control unit connector and ground.

Connector	Terminal (Wire color)		Condition	Voltage (V) (Approx)
	(+)	(-)		
B159 (Driver side), B359 (Passenger side)	J14 (W)	Ground	Climate controlled seat switch "HEAT" or "COOL" temperature dial 1 – 4.	5 – 7
			Climate controlled seat switch OFF.	0

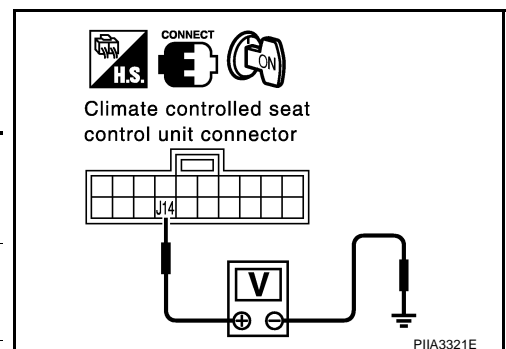

OK or NG

- OK >> GO TO 2.
- NG >> Replace climate controlled seat blower motor.

CLIMATE CONTROLLED SEAT

2. CHECK BLOWER MOTOR HARNESS

1. Turn ignition switch OFF.
2. Disconnect climate controlled seat control unit connector and blower motor connector.
3. Check continuity between climate controlled seat control unit connector B159 (driver side), B359 (passenger side) terminal J14 (W) and blower motor connector B155 (driver side), B355 (passenger side) terminal J14 (W).

J14 (W) – J14 (W) : Continuity should exist

4. Check continuity between climate controlled seat control unit connector B159 (driver side), B359 (passenger side) terminal J14 (W) and ground.

J14 (W) – Ground : Continuity should not exist

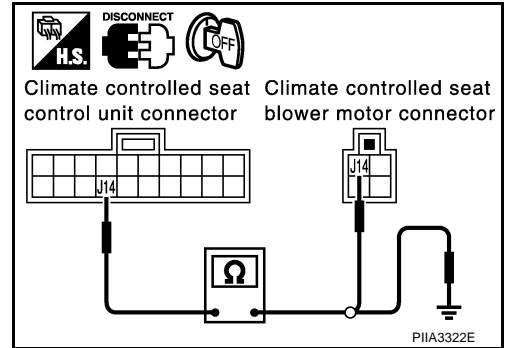

OK or NG

- OK >> Blower motor tachometer signal circuit check is OK.
NG >> Repair or replace harness.

Climate Controlled Seat Control Unit Inspection

EIS008N3

1. CHECK THE CLIMATE CONTROLLED SEAT CONTROL UNIT

Does the heater operate normally when the driver side or passenger side climate controlled seat control unit is exchanged?

YES or NO

- YES >> Climate controlled seat control unit check is OK.
NO >> Replace climate controlled seat control unit.

A
B
C
D
E
F
G
H
SE
J
K
L
M

FRONT SEAT

PFP:87000

FRONT SEAT

Removal and Installation DRIVER SIDE POWER SEAT

EIS000FJ

SEC. 870

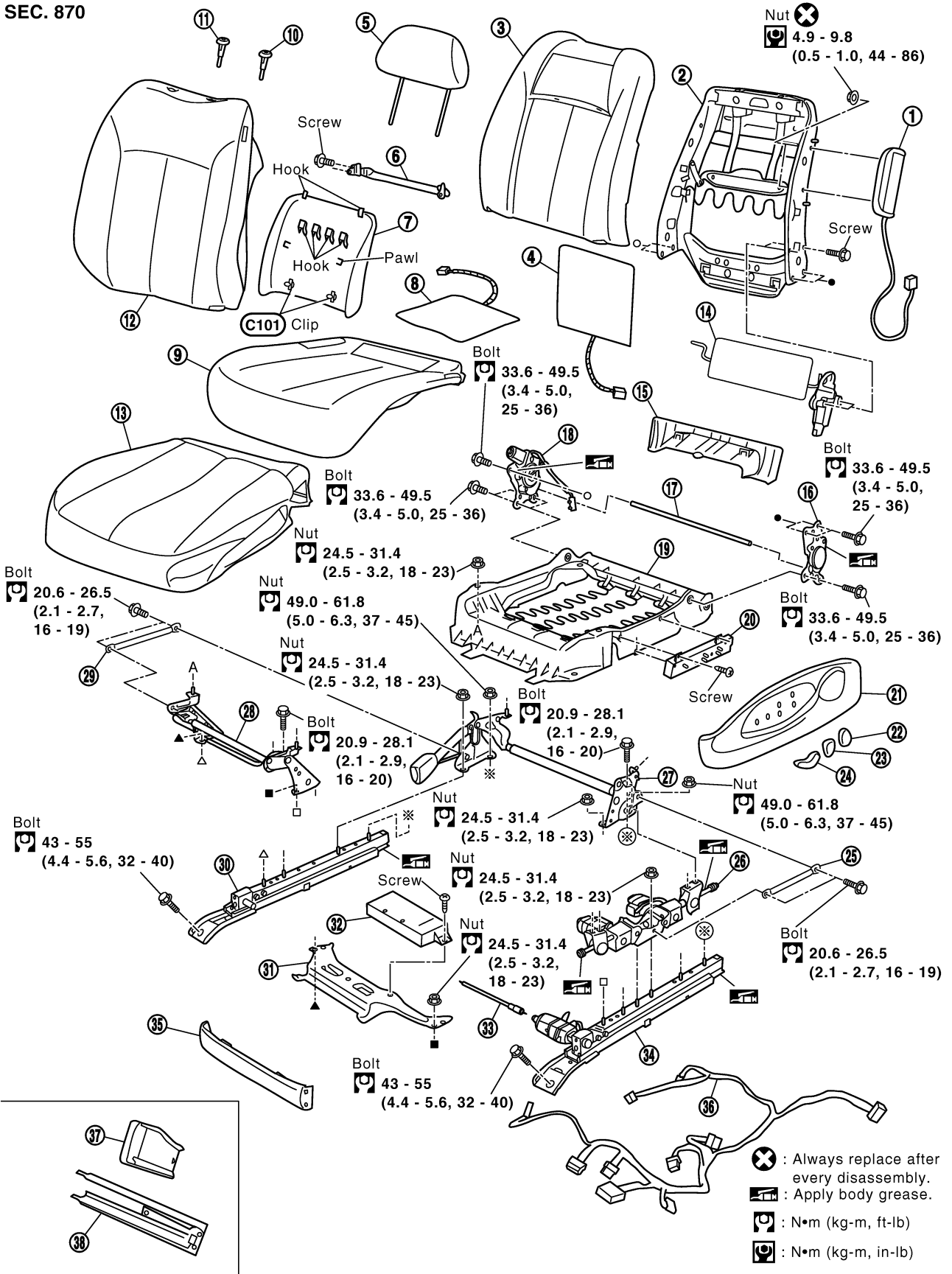

PIIA0162E

FRONT SEAT

-
- | | | |
|--------------------------------------|---------------------------------|-------------------------------------|
| 1. Side air bag module | 2. Seatback frame | 3. Seatback pad |
| 4. Seatback heater unit | 5. Headrest | 6. Seatback grip belt |
| 7. Seatback board | 8. Seat cushion heater unit | 9. Seat cushion pad |
| 10. Headrest holder (locked) | 11. Headrest holder (free) | 12. Seatback trim |
| 13. Seat cushion trim | 14. Seat lumbar unit | 15. Seat cushion rear finisher |
| 16. Reclining device (LH) | 17. Reclining device rod | 18. Reclining device (RH) |
| 19. Seat cushion frame | 20. Power seat switch | 21. Seat cushion outer finisher |
| 22. Lumbar support switch knob | 23. Reclining switch knob | 24. Slide-lifter switch knob |
| 25. Seat cushion rod (LH) | 26. Lifter motor unit assembly | 27. Seat lifter link bracket (rear) |
| 28. Seat lifter link bracket (front) | 29. Seat cushion rod (RH) | 30. Inner sliding assembly |
| 31. Seat control unit bracket | 32. Seat control unit | 33. Flexible wire |
| 34. Outer sliding assembly | 35. Seat cushion front finisher | 36. Power seat harness |
| 37. Front leg cover (LH/RH) | 38. Rear leg cover (LH/RH) | |

A

B

C

D

E

F

G

H

SE

J

K

L

M

FRONT SEAT

CLIMATE CONTROLLED SEAT

SEC. 870

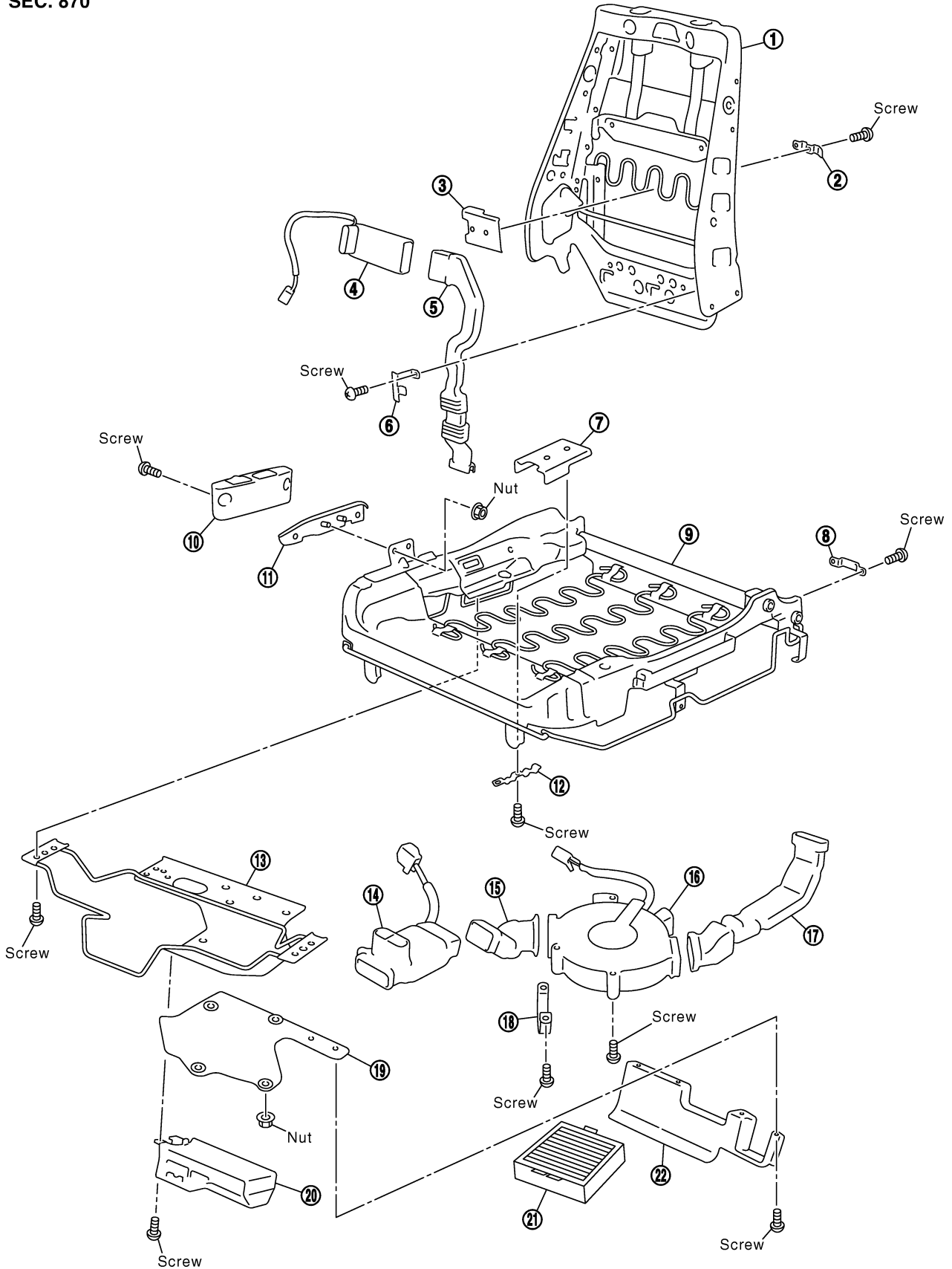

PIIB0507E

FRONT SEAT

-
- | | | | |
|--|--|-------------------------------------|---|
| 1. Seatback frame | 2. Seatback outer bracket | 3. Seatback inner bracket | |
| 4. Seatback thermal electric device | 5. Seatback duct | 6. Seatback duct upper bracket | A |
| 7. Seat cushion inner bracket | 8. Seatback duct lower bracket | 9. Seat cushion frame | |
| 10. Climate controlled seat switch | 11. Climate controlled seat switch bracket | 12. Seat cushion outer bracket | B |
| 13. Seat cushion mounting upper bracket | 14. Seat cushion thermal electric device | 15. Seat cushion front duct | |
| 16. Climate controlled seat blower motor | 17. Seat cushion rear duct | 18. Seat cushion duct lower bracket | C |
| 19. Seat cushion mounting lower bracket | 20. Climate controlled seat control box | 21. Climate controlled seat filter | D |
| 22. Seat cushion rear duct cover | | | E |

SE

J

K

L

M

FRONT SEAT

- | | | |
|--------------------------------------|-------------------------------------|--------------------------------------|
| 1. Side air bag module | 2. Seatback frame | 3. Power seat switch (seatback) |
| 4. Seatback pad | 5. Seatback heater unit | 6. Headrest |
| 7. Seatback grip belt | 8. Seatback board | 9. Seat cushion heater unit |
| 10. Seat cushion pad | 11. Headrest holder (free) | 12. Headrest holder (locked) |
| 13. Seatback trim | 14. Seat cushion rear finisher | 15. Reclining device (RH) |
| 16. Reclining device rod | 17. Reclining device (LH) | 18. Seat cushion frame |
| 19. Power seat switch (seat cushion) | 20. Seat cushion trim | 21. Seat cushion outer finisher |
| 22. Reclining switch knob | 23. Slide-lifter switch knob | 24. Seat cushion rod (RH) |
| 25. Lifter motor assembly | 26. Seat lifter link bracket (rear) | 27. Seat lifter link bracket (front) |
| 28. Seat cushion rod (LH) | 29. Inner sliding assembly | 30. Seat control unit bracket |
| 31. Flexible wire | 32. Outer sliding assembly | 33. Seat cushion front finisher |
| 34. Power seat harness | 35. Front leg cover (LH/RH) | 36. Rear leg cover (LH/RH) |

REMOVAL

When removing or installing the seat trim, carefully handle it to keep dirt out and avoid damage.

CAUTION:

- Before removing the front seat, turn the ignition switch off, disconnect both battery cables and wait at least 3 minutes.
 - When checking the power seat circuit for continuity using a circuit tester, do not confuse its connector with the side air bag module connector. Such an error may cause the air bag to deploy.
 - Do not drop, tilt, or bump the side air bag module installing in the seat. Always handle it with care.
1. Remove the front leg cover and rear leg cover. (LH/RH)

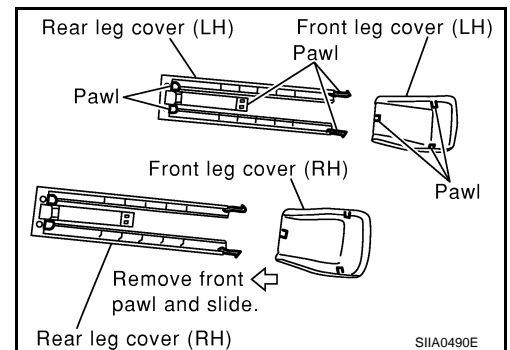

NOTE:

- Slide the seat backward, and disconnect the front tabs on the front leg cover. Then move the cover toward the rear of the vehicle, and pull up to remove.
 - Slide the seat forward, then disengage the tabs on the front LH/RH of the rear leg cover and tabs engaged into the rail. Then pull the cover toward the rear of the vehicle.
2. Slide the seat until the body mounting bolts are visible and a tool can be inserted.

NOTE:

When disassembling the driver seat after removal, set the front/rear cushion lifter to the top position.

3. Remove the body mounting bolts.
4. Remove the seat belt anchor bolt. Refer to [SB-4, "Removal and Installation of Front Seat Belt"](#).
5. Disconnect both battery cables.
6. Remove the harness connector for the side air bag module.
7. Remove the power seat harness connector and vehicle harness fixing clip out of the vehicle.

NOTE:

When removing and installing, using shop clothes, protect the parts from damage where it may interfere with others.

FRONT SEAT

INSTALLATION

Install in the reverse order of removal.

NOTE:

Be sure to insert the rear end tab of the rear leg cover under the rail.

Disassembly and Assembly DISASSEMBLY OF SEATBACK TRIM AND PAD

EIS003R2

NOTE:

Be sure to set the front/rear cushion lifter to the top position.

1. Remove the seatback board from the back of the seatback.

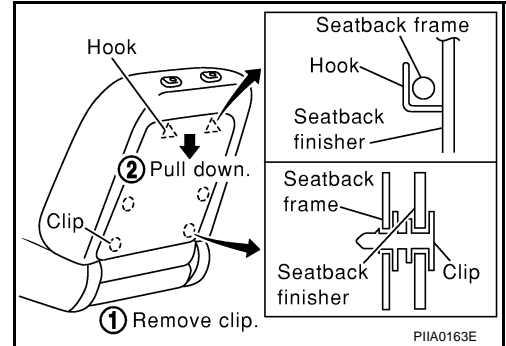

2. Remove the retainer.

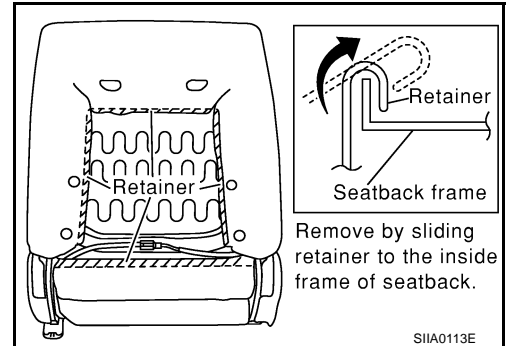

3. From the back of the seatback, press the headrest holder tab of the stay pipe hole to disengage. Then pull the headrest holder up to remove.

NOTE:

Before installing the headrest holder, check its orientation (front/rear and left/right).

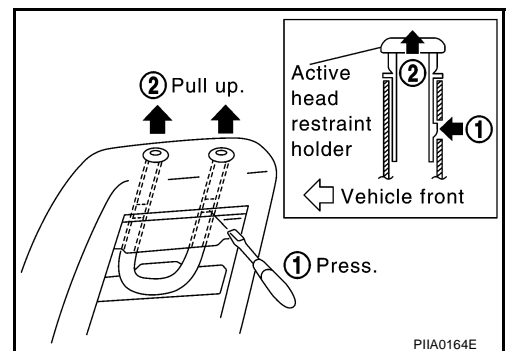

4. Remove the stay securing the inner cloth.

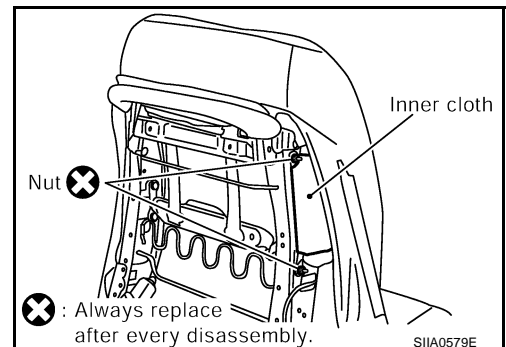

FRONT SEAT

5. Remove the switch finisher at the side of the seatback. (passenger side seat only)

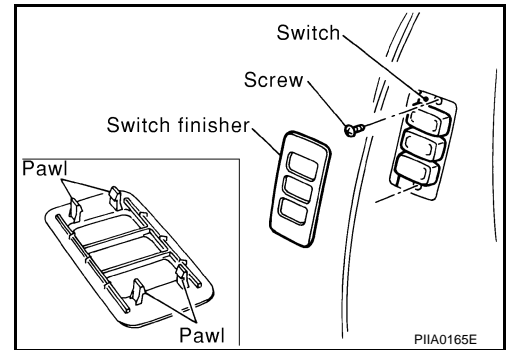

6. Remove the seat heater harness connector. After removing the seatback trim and pad, remove the hog ring to separate the trim, pad, and seatback heater unit.

ASSEMBLY OF SEATBACK TRIM AND PAD

Assemble in the reverse order of disassembly.

REMOVAL OF SEATBACK ASSEMBLY

1. After completing the steps 1 and 2 of "SEATBACK TRIM AND PAD", remove the harness connectors for the reclining motor and lumbar support motor (driver seat only).
2. Pull out the harness connector for the side air bag from the seat cushion.
3. Remove the reclining device mounting bolts on the seatback frame, and remove the seatback assembly.

NOTE:

When assembling the seatback frame, make sure that the reclining device are locked on both sides, and be sure to temporarily tighten the bolts, then tighten them finally.

INSTALLATION OF SEATBACK ASSEMBLY

Install in the reverse order of removal.

DISASSEMBLY OF SEAT CUSHION TRIM AND PAD

1. Remove the front seat cushion finisher (front and rear).
2. Remove the power seat switch knob.
3. Remove the front seat cushion finisher (outer).

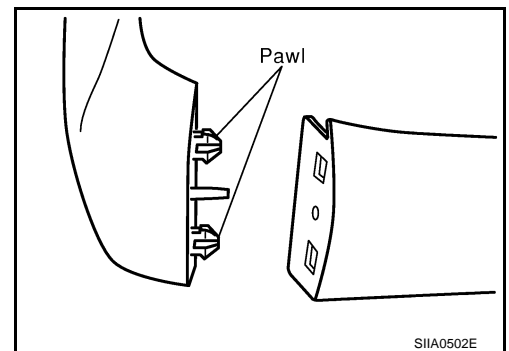

4. Remove the power seat switch assembly.
5. Partially pull off the trim at the rear of the seat cushion forward, and remove the hog rings on the seat cushion pad.

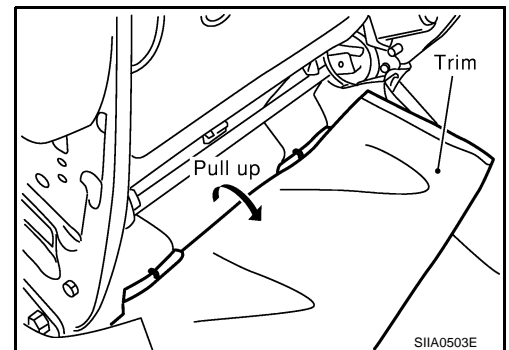

6. Remove the retainer on the seat cushion frame, then remove the harness connector for the seat heater.
7. After removing the seat cushion trim and pad, remove the hog rings to separate the trim and pad and the seat cushion heater unit.

FRONT SEAT

ASSEMBLY OF SEAT CUSHION TRIM AND PAD

Assemble in the reverse order of disassembly.

CLIMATE CONTROLLED SEAT

Blower Filter Replacement

Put your hand behind front seat cushion, pull filter downward and remove it. Replace filter with a new one.

NOTE:

- When replacing, be sure to set the front/rear driver seat lifter to the top position.
- When installing, do not confuse up-down direction of the filter.

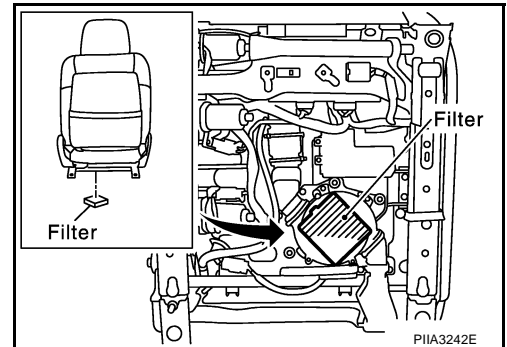

REAR SEAT

PFP:88300

EIS0046J

REAR SEAT

Removal and Installation MANUAL SEAT (BENCH SEAT)

A
B
C
D
E
F
G
H
SE
J
K
L
M

SEC. 880

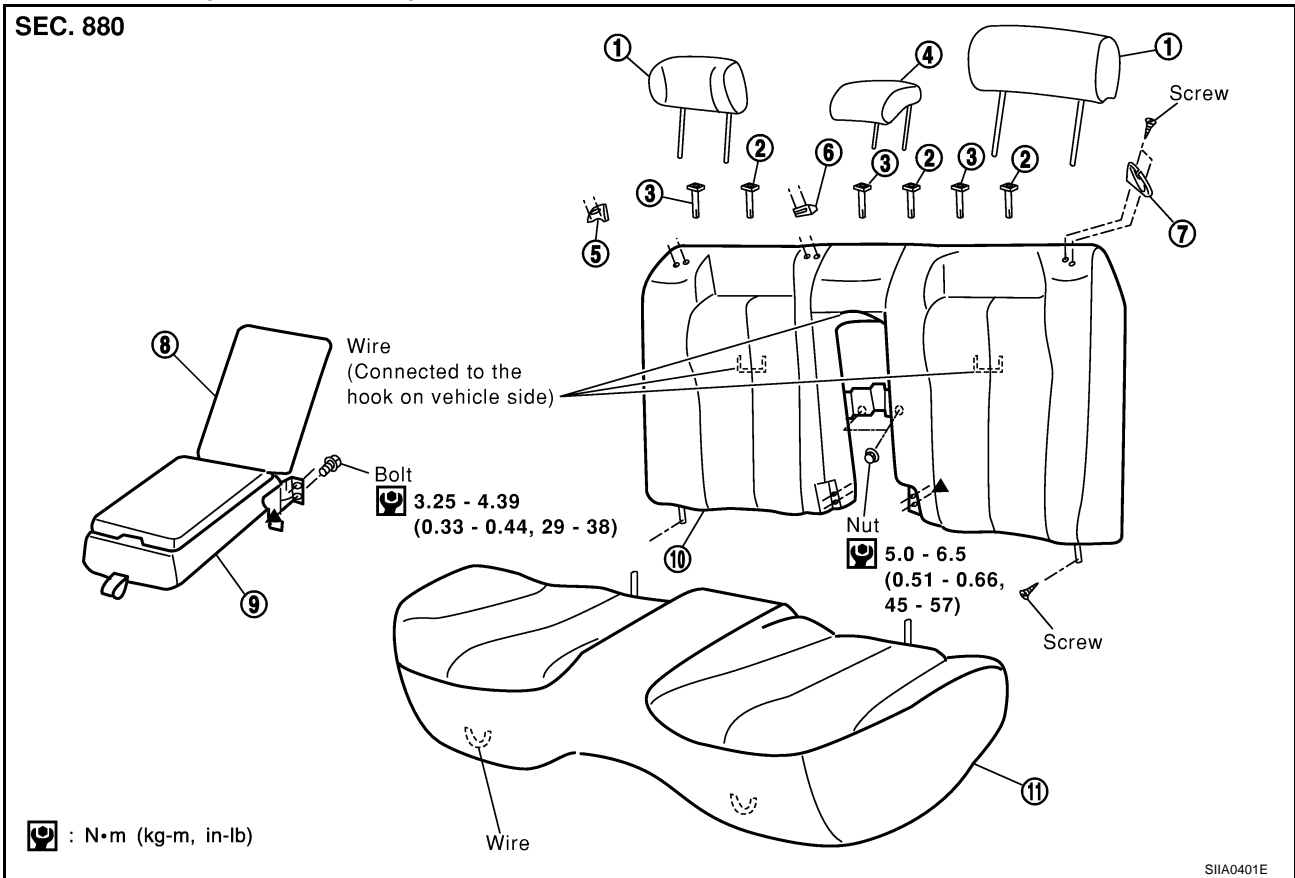

- | | | |
|--------------------------------|------------------------------------|-----------------------------|
| 1. Headrest (RH/LH) | 2. Headrest holder (locked) | 3. Headrest holder (free) |
| 4. Headrest (center) | 5. Seat belt guide (RH) | 6. Seat belt guide (center) |
| 7. Seat belt guide (LH) | 8. Rear seatback board | 9. Rear seat armrest |
| 10. Rear seatback trim and pad | 11. Rear seat cushion trim and pad | |

REAR SEAT

- | | | |
|------------------------------------|--|---------------------------------|
| 1. Rear seatback frame (RH) | 2. Headrest (center) | 3. Rear seatback board |
| 4. Headrest holder | 5. Rear center seatback assembly | 6. Rear seatback frame (LH) |
| 7. Rear seat hook | 8. Headrest (RH) | 9. Rear seat cushion frame (RH) |
| 10. Headrest (LH) | 11. Rear seat cushion frame (LH) | 12. Rear power seat harness A |
| 13. Ground harness | 14. Headrest holder (free) | 15. Headrest holder (locked) |
| 16. Seat belt guide (RH) | 17. Seat belt guide (center) | 18. Headrest holder (power RH) |
| 19. Headrest holder (power LH) | 20. Seat belt guide (LH) | 21. Seatback trim and pad (RH) |
| 22. Seatback trim (LH) | 23. Seatback pad (LH) | 24. Seatback heater unit |
| 25. Seat cushion trim and pad (RH) | 26. Seat cushion trim and pad (center) | 27. Seat cushion trim (LH) |
| 28. Seat cushion pad (LH) | 29. Seat cushion heater unit | 30. Rear power seat harness B |
| 31. Rear seat slide, outer (RH) | 32. Power seat control unit (RH) | 33. Sliding motor unit (RH) |
| 34. Rear seat slide, inner (RH) | 35. Rear seat slide, inner (LH) | 36. Seat control unit (LH) |
| 37. Sliding motor unit (LH) | 38. Rear seat slide, outer (LH) | |

CENTER SEATBACK ASSEMBLY

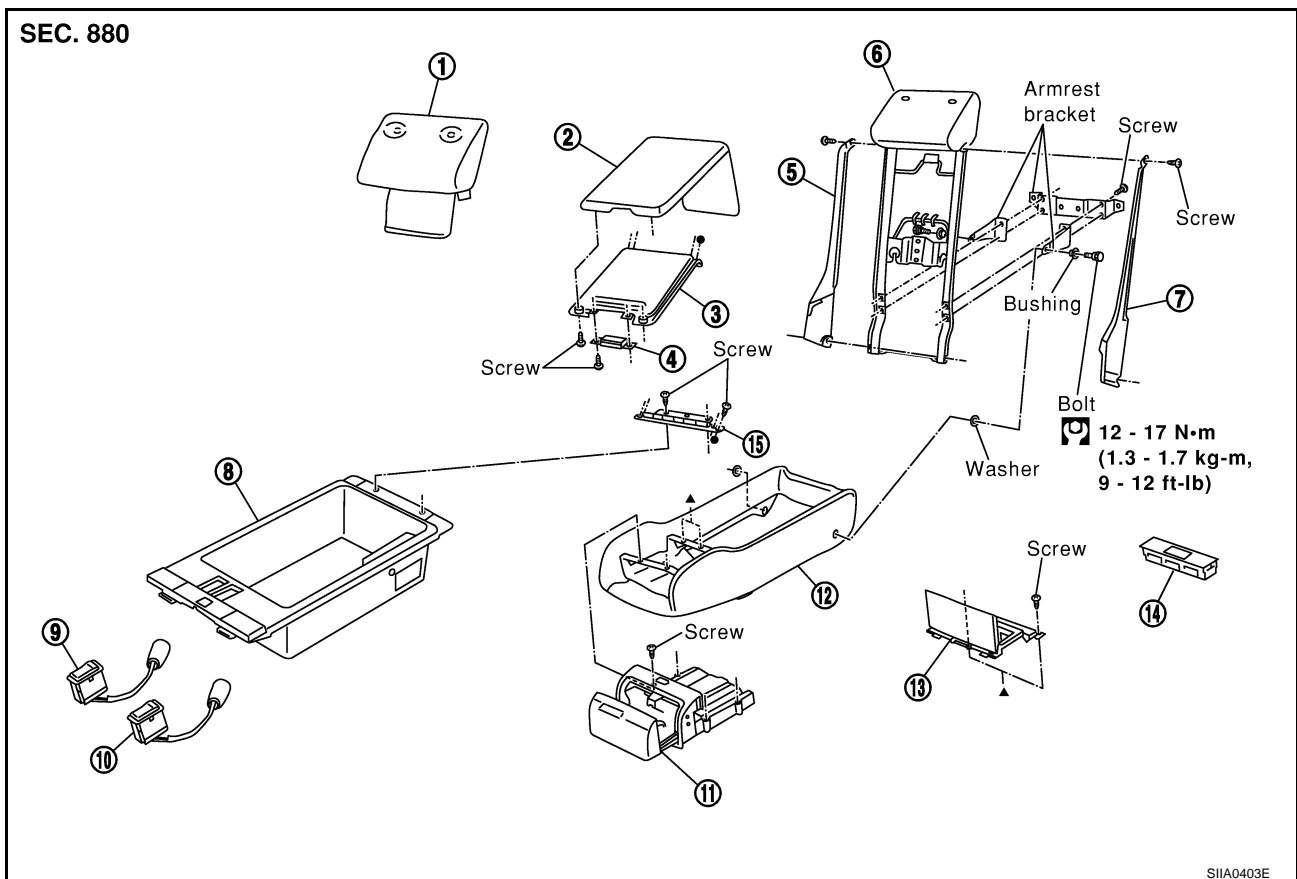

- | | | |
|--------------------------------|----------------------------------|--|
| 1. Rear seatback trim (center) | 2. Armrest lid assembly | 3. Armrest lid finisher |
| 4. Armrest lid lock | 5. Seatback side screen (RH) | 6. Rear seat center back frame and pad |
| 7. Seatback side screen (LH) | 8. Armrest tray box | 9. TV and sunshade switch |
| 10. Seat switch | 11. Cup holder | 12. Armrest frame and pad |
| 13. Switch lid | 14. Rear control switch assembly | 15. Lid hinge |

REAR SEAT

REMOVAL OF MANUAL SEAT (BENCH SEAT)

1. Pull the lock at the front bottom of the seat cushion forward and pull the seat cushion upward to release the wire from the plastic hook, then pull the seat cushion forward to remove.

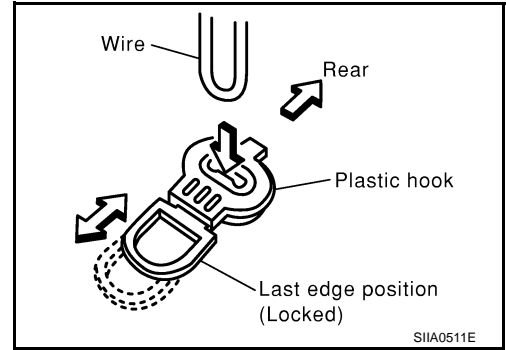

2. Partially remove the seatback board to disconnect the harness connector and remove the nuts on the sunshade switch.
3. Remove the RH and LH screws on the seatback.
4. Slide the seatback upward to pull off the wire from the vehicle-side hook, and remove the seatback.
5. After removing, remove the hog ring to separate the trim and pad.

INSTALLATION OF MANUAL SEAT (BENCH SEAT)

Install in the reverse order of removal.

REMOVAL OF POWER SEAT (SPLIT SEAT)

NOTE:

Remove the LH and RH seat before removing the center seat.

Center Seat

1. Pull the lock at the front bottom of the seat cushion forward, and pull the seat cushion upward to release the wire from the plastic hook.

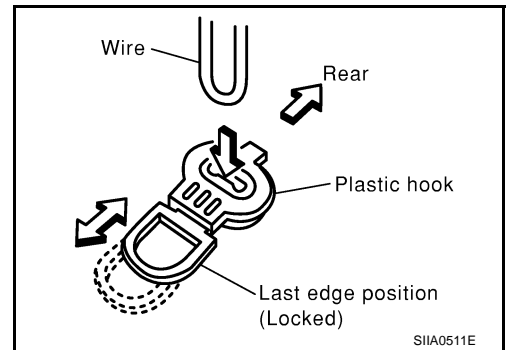

2. Remove the Velcro fastener at the rear of the seat cushion trim, and pull the seat cushion trim forward to remove.
3. Partially remove the seatback board to disconnect the harness connectors for rear control switch and rear seat control unit.
4. Remove the nuts and slide the center seatback assembly upward to remove.
5. After removing, remove the hog ring to separate the trim and pad.

RH/LH Seat

1. Remove the headrest holders at the right and left.
 - For the RH seat, remove the headrest, and turn the headrest holder toward the front of the vehicle by 90° to remove.
 - For the LH seat, move the headrest to the lower limit to remove it. Then insert a slotted screwdriver into the hole on the headrest holder to pull up. Release the tab on the headrest holder to remove the headrest holder.

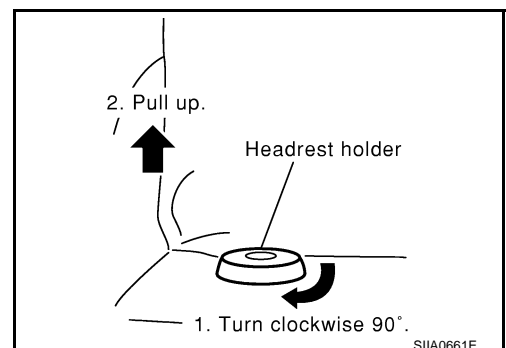

REAR SEAT

2. Raise the bottom of the seat cushion to release the wire from the plastic hook then pull the seat cushion forward to remove. (For the LH seat, disconnect the harness connector for the seat heater).

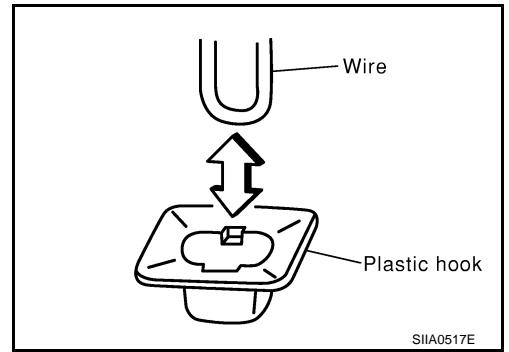

3. Access the hooks from between the seatback pad and rear seatback frame, and pull them downward to remove the wire. Then, slide the seatback upward to remove.
4. Remove nuts and bolts to remove the power unit frame assembly.

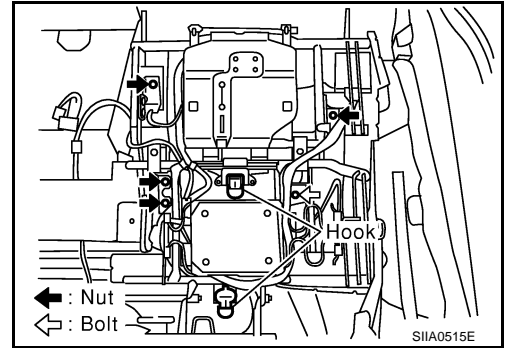

5. Remove the mounting bolts and disconnect the vehicle-side harness connector on the seat cushion frame.

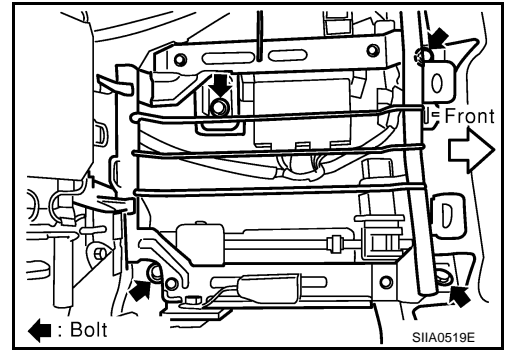

6. After removing, remove the hog ring to separate the trim and pad, and rear seat heater unit (only LH-side).

INSTALLATION OF POWER SEAT (SPLIT SEAT)

Install in the reverse order of removal.

Disassembly and Assembly DISASSEMBLY OF SLIDING MOTOR & UNIT

EIS000FO

1. Remove mounting bolts and screws on the lead screw unit.

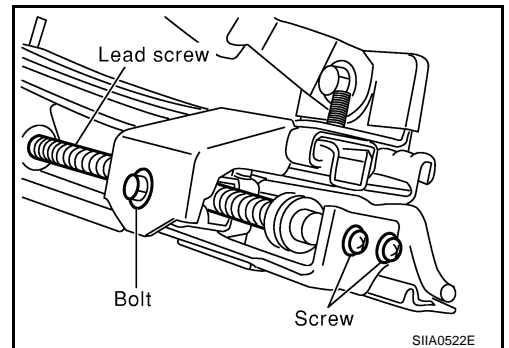

REAR SEAT

2. Remove the sliding motor mounting bolt.

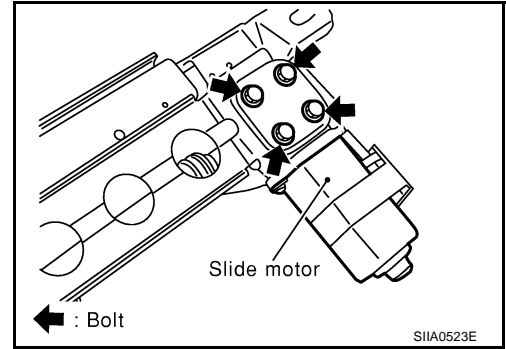

3. Slide the unit mounting bracket backward (on seat belt buckle side) to make space to take the unit out.
4. Pull the sliding motor and unit out of the unit mounting bracket.

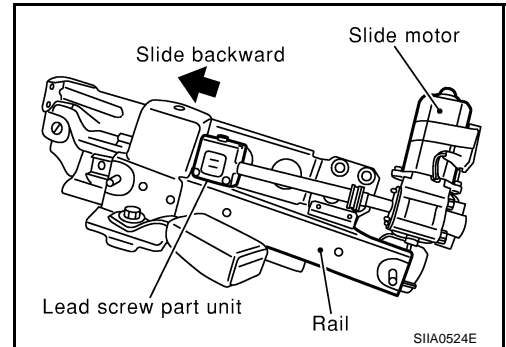

ASSEMBLY OF SLIDING MOTOR & UNIT

Assemble in the reverse order of disassembly.

NOTE:

When installing the sliding rail to the seat cushion frame, slide the outer rail until it aligns to the inner rail, then install it.

DISASSEMBLY OF CENTER SEATBACK ASSEMBLY

1. Remove the seatback board.

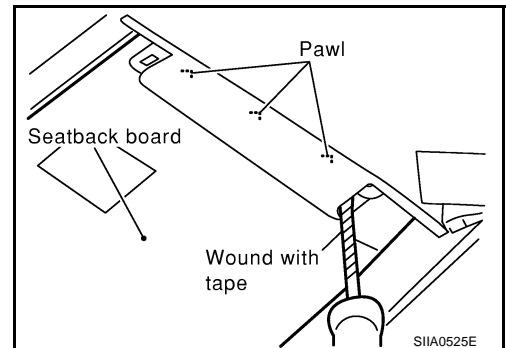

2. Remove the seatback side screen at the right and left.
3. Remove the armrest bracket.
4. Remove the hog ring on the rear seatback trim (center) and headrest holder.

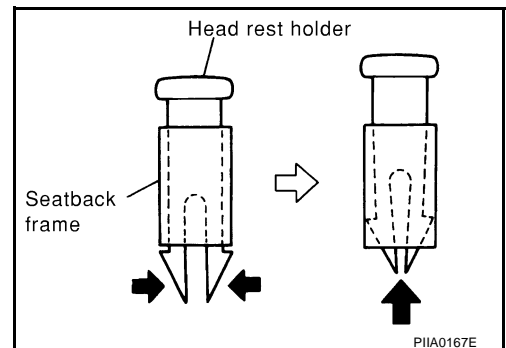

5. Remove the armrest lid hinge and armrest lid lock.

REAR SEAT

6. Release the tabs on the armrest box, and disconnect the connectors for various switches.
7. Release the tab for each switch from the armrest box to separate.
8. Disconnect the connector for the rear control switch to remove the switch lid and rear control switch.

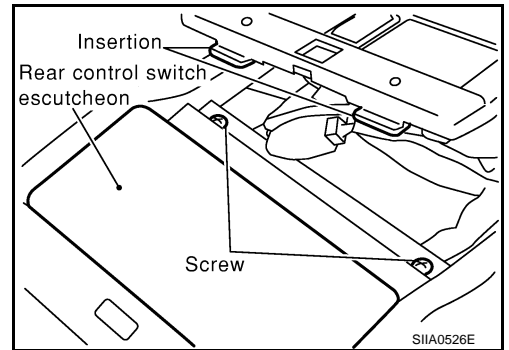

9. Remove the cup holder assembly.

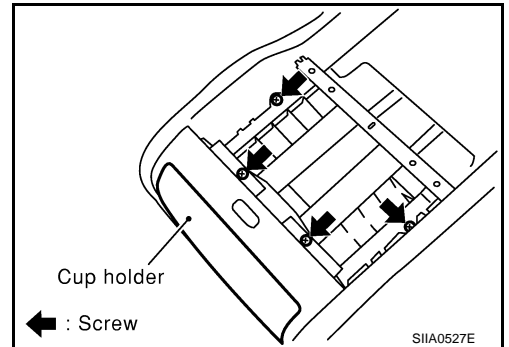

ASSEMBLY OF CENTER SEATBACK ASSEMBLY

Assemble in the reverse order of disassembly.

A
B
C
D
E
F
G
H

SE

J
K
L
M

REAR SEAT
