

A
LU
C

SECTION LU

ENGINE LUBRICATION SYSTEM

CONTENTS

PRECAUTIONS	2	OIL FILTER	9	
Precautions for Liquid Gasket	2	Removal and Installation	9	
LIQUID GASKET APPLICATION PROCEDURE....	2	REMOVAL	9	
PREPARATION	3	INSTALLATION	9	G
Special Service Tools	3	INSPECTION AFTER INSTALLATION	9	
Commercial Service Tools	3	OIL PUMP	10	
LUBRICATION SYSTEM	4	Removal and Installation	10	H
Lubrication Circuit	4	REMOVAL	10	
System Chart	5	INSTALLATION	10	
ENGINE OIL	6	INSPECTION AFTER INSTALLATION	10	
Inspection	6	Disassembly and Assembly	11	I
ENGINE OIL LEVEL	6	DISASSEMBLY	11	
ENGINE OIL APPEARANCE	6	INSPECTION AFTER DISASSEMBLY	11	
ENGINE OIL LEAKAGE	6	ASSEMBLY	12	J
OIL PRESSURE CHECK	6	SERVICE DATA AND SPECIFICATIONS (SDS)	13	
Changing Engine Oil	7	Standard and Limit	13	
		OIL PRESSURE	13	K
		OIL PUMP	13	
		REGULATOR VALVE	13	
		ENGINE OIL CAPACITY	13	L

A
LU
C
D
E
F
G
H
I
J
K
L
M

PRECAUTIONS

PRECAUTIONS

PFP:00001

Precautions for Liquid Gasket LIQUID GASKET APPLICATION PROCEDURE

NBS001P6

1. Remove old liquid gasket adhering to the liquid gasket application surface and the mating surface.
 - Remove liquid gasket completely from the liquid gasket application surface, mounting bolts, and bolt holes.
2. Wipe the liquid gasket application surface and the mating surface with white gasoline (lighting and heating use) to remove adhering moisture, grease and foreign materials.
3. Attach liquid gasket tube to tube presser (SST).

Use Genuine RTV Silicone Sealant or equivalent. Refer to [GI-45, "RECOMMENDED CHEMICAL PRODUCTS AND SEALANTS"](#) .

- Within 5 minutes of liquid gasket application, install the mating component.
- If liquid gasket protrudes, wipe it off immediately.
- Do not retighten mounting bolts or nuts after the installation.
- After 30 minutes or more have passed from the installation, fill engine oil and engine coolant.

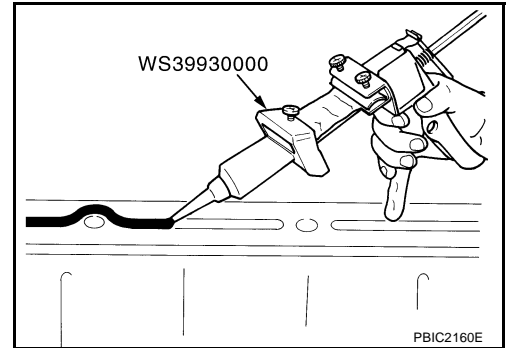

PREPARATION

PREPARATION

PPF:00002

Special Service Tools

NBS001P7

The actual shapes of Kent-Moore tools may differ from those of special service tools illustrated here.

Tool number (Kent-Moore No.) Tool name	Description
ST25051001 (J25695-1) Oil pressure gauge	Measuring oil pressure Maximum measuring range: 2,452 kPa (25 kg/cm², 356 psi)
ST25052000 (J25695-2) Hose	Adapting oil pressure gauge to cylinder block
KV10115801 (J38956) Oil filter wrench	Removing and installing oil filter a: 64.3 mm (2.531 in)
WS39930000 (—) Tube presser	Pressing the tube of liquid gasket

Commercial Service Tools

NBS001P8

Tool name	Description
Deep socket	Removing and installing oil pressure switch Deep socket 26 mm (1.02 in)
Power tool	Loosening bolts and nuts

LUBRICATION SYSTEM

LUBRICATION SYSTEM

PFP:15010

Lubrication Circuit

NBS001P9

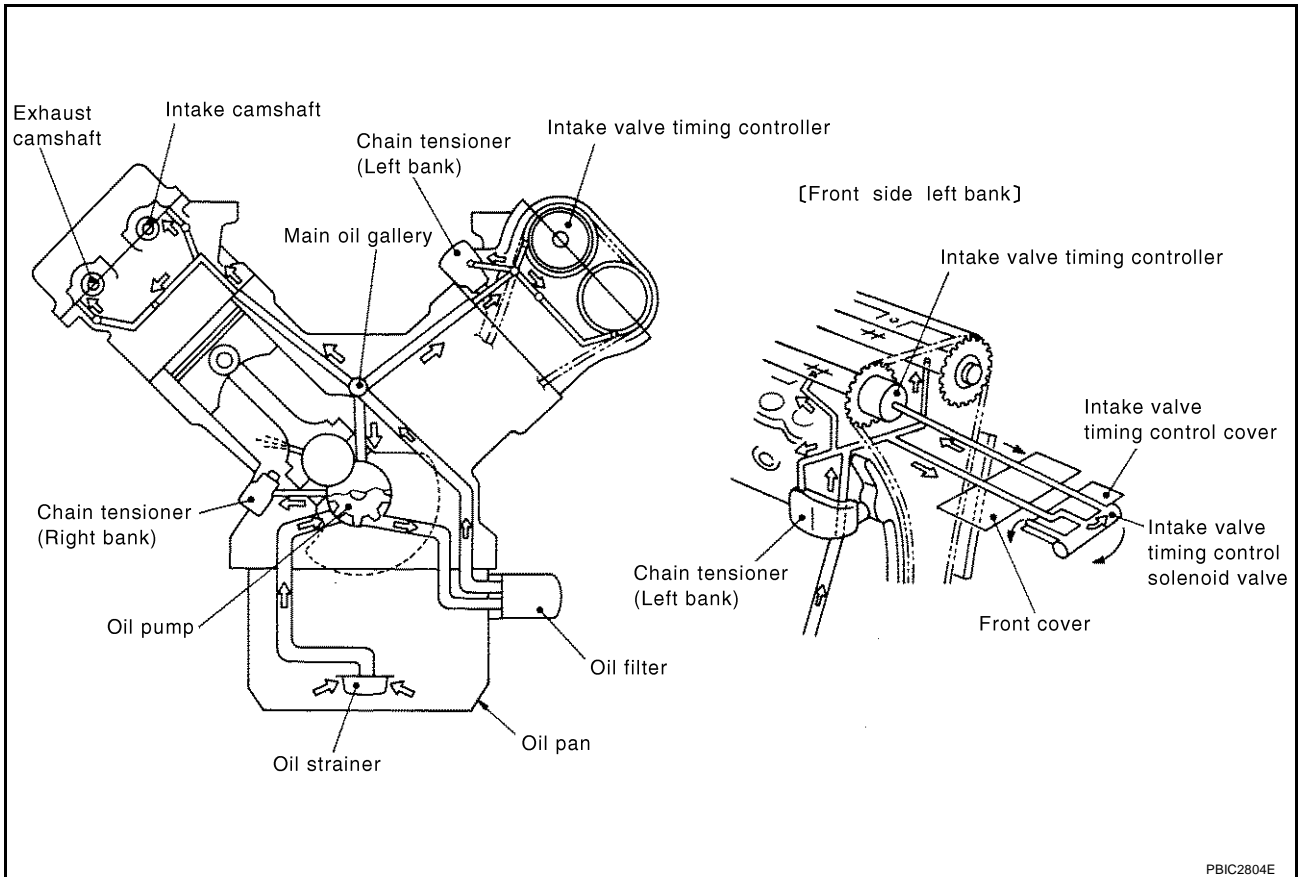

LUBRICATION SYSTEM

System Chart

NBS001PA

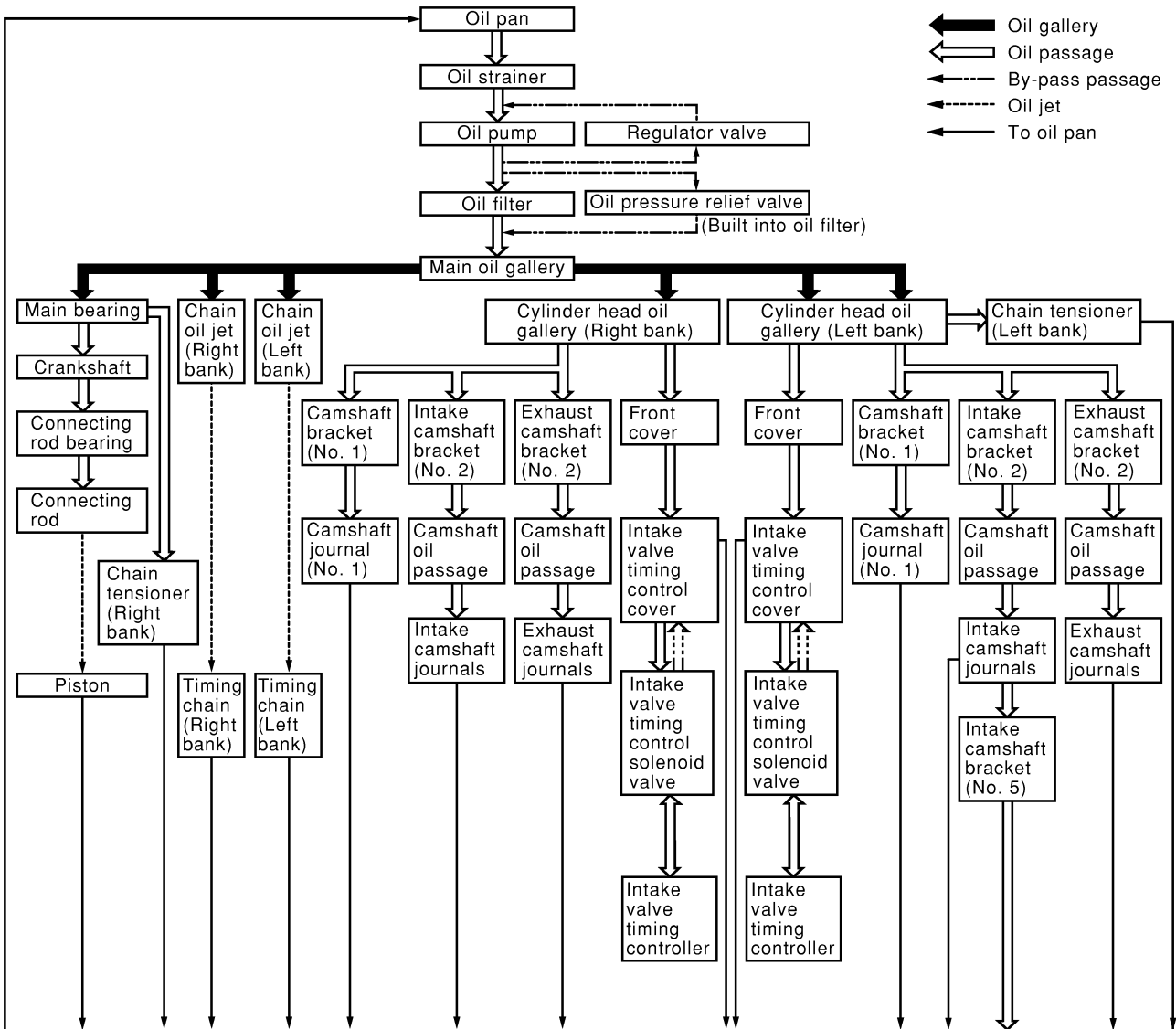

PBIC0134E

A
LU
C
D
E
F
G
H
I
J
K
L
M

ENGINE OIL

ENGINE OIL

PFP:KLA92

Inspection ENGINE OIL LEVEL

NBS001PB

NOTE:

Before starting engine, check the engine oil level. If engine is already started, stop it and allow 15 minutes before checking.

1. Put vehicle horizontally.
2. Pull out oil level gauge and wipe it clean.
3. Insert oil level gauge and make sure that the engine oil level is within the range shown in the figure.
4. If it is out of range, adjust it.

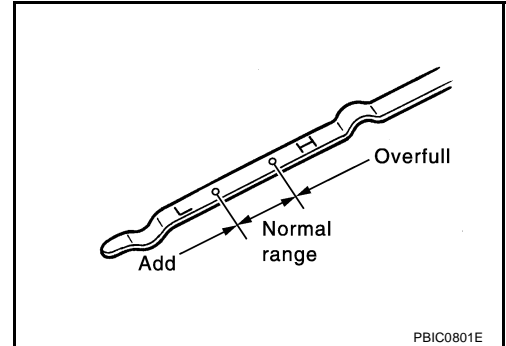

ENGINE OIL APPEARANCE

- Check engine oil for a white turbidity or heavy contamination.
- If engine oil becomes turbid and white, it is highly probable that it is contaminated with engine coolant. Repair or replace damaged parts.

ENGINE OIL LEAKAGE

Check for engine oil leakage around the following area.

- Oil pan
- Oil pan drain plug
- Oil pressure switch
- Oil filter
- Intake valve timing control cover
- Intake valve timing control solenoid valve
- Front cover
- Mating surface between cylinder block and cylinder head
- Mating surface between cylinder head and rocker cover
- Crankshaft oil seal (front and rear)

OIL PRESSURE CHECK

WARNING:

- **Be careful not to burn yourself, as engine oil is hot.**
 - **Engine oil pressure check should be done in "Parking position".**
1. Check engine oil level. Refer to [LU-6, "ENGINE OIL LEVEL"](#).
 2. Remove engine undercover with power tool.
 3. Disconnect oil pressure switch harness connector.
 4. Remove oil pressure switch using the deep socket (commercial service tool).

CAUTION:

Do not drop or shock oil pressure switch.

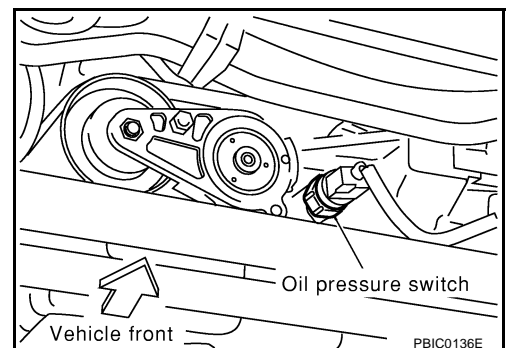

ENGINE OIL

5. Install oil pressure gauge and hose [SST].

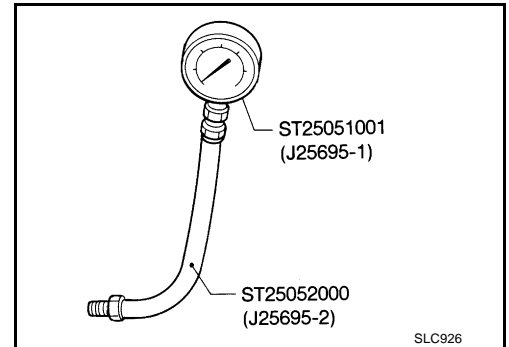

6. After warming up engine to normal operating temperature, make sure that engine oil pressure corresponding to the engine speed is produced.

NOTE:

When engine oil temperature is low, the engine oil pressure becomes high.

Engine oil pressure [Engine oil temperature at 80 °C (176 °F)]

Engine speed (rpm)	Idle speed	2,000
Oil pressure kPa (kg/cm ² , psi)	98 (1.0, 14)	294 (3.0, 43)

If difference is extreme, check the oil passage and oil pump for engine oil leaks.

7. After checking, install oil pressure switch as follows.
 - a. Remove old liquid gasket adhering to oil pressure switch and engine.
 - b. Apply thread sealant and tighten oil pressure switch to the specification.
Use Genuine Thread Sealant or equivalent. Refer to [GI-45, "RECOMMENDED CHEMICAL PRODUCTS AND SEALANTS"](#) .

Oil pressure switch:

: 14.8 N·m (1.5 kg·m, 11 ft·lb)

- c. After warming up the engine, make sure there is no leaks of engine oil with running the engine.

Changing Engine Oil

NBS001PC

WARNING:

- Be careful not to burn yourself, as engine oil is hot.
- Prolonged and repeated contact with used engine oil may cause skin cancer; try to avoid direct skin contact with used engine oil. If skin contact is made, wash thoroughly with soap or hand cleaner as soon as possible.

1. Open oil filter installation/removal cover on engine undercover.
2. Warm up engine, put vehicle horizontally and check for engine oil leakage from engine components. Refer to [LU-6, "ENGINE OIL LEAKAGE"](#)
3. Stop engine and wait for 15 minutes.
4. Loosen oil filler cap, then remove drain plug.
5. Drain engine oil.
6. Install drain plug with new washer. Refer to [EM-26, "OIL PAN AND OIL STRAINER"](#) .

CAUTION:

- Be sure to clean drain plug and install with new washer.

Oil pan drain plug:

: 34.3 N·m (3.5 kg·m, 25 ft·lb)

7. Refill with new engine oil.

Engine oil specification and viscosity:

Refer to [MA-10, "RECOMMENDED FLUIDS AND LUBRICANTS"](#) .

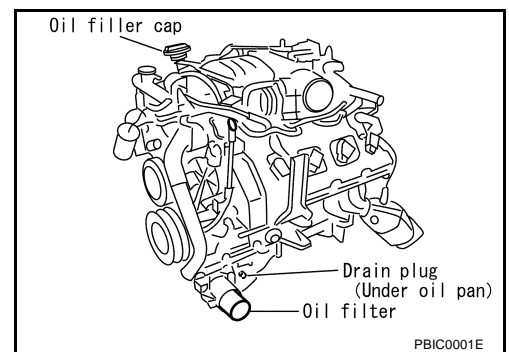

ENGINE OIL

Engine oil capacity (Approximate):

Unit: ℓ (US qt, Imp qt)

Drain and refill	With oil filter change	5.6 (5-7/8, 4-7/8)
	Without oil filter change	5.0 (5-1/4, 4-3/8)
Dry engine (engine overhaul)		6.7 (7-1/8, 5-7/8)

CAUTION:

- **The refill capacity depends on the engine oil temperature and drain time. Use these specifications for reference only.**
 - **Always use oil level gauge to determine when the proper amount of engine oil is in engine.**
8. Warm up engine and check area around drain plug and oil filter for oil leakage.
 9. Stop engine and wait for 15 minutes.
 10. Check the engine oil level. Refer to [LU-6, "Inspection"](#) .

OIL FILTER

OIL FILTER

PFP:15208

Removal and Installation

NBS001PD

REMOVAL

1. Open oil filter installation/removal cover on engine undercover.
2. Using the oil filter wrench (SST), remove oil filter.

CAUTION:

- Oil filter is provided with a relief valve.
Use Genuine NISSAN Oil Filter or equivalent.
- Be careful not to get burned when engine and engine oil may be hot.
- When removing, prepare a shop cloth to absorb any engine oil leakage or spillage.
- Do not allow engine oil to adhere to drive belts.
- Completely wipe off any engine oil that adhere to engine and the vehicle.

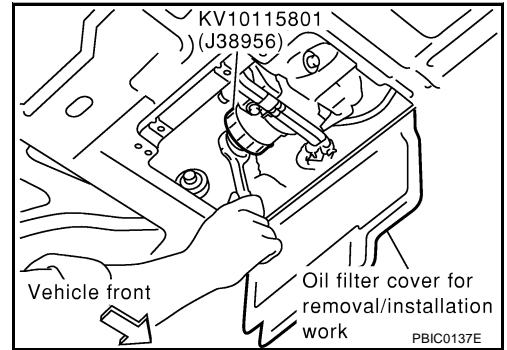

INSTALLATION

1. Remove foreign materials adhering to the oil filter installation surface.
2. Apply new engine oil to the oil seal contact surface of new oil filter.

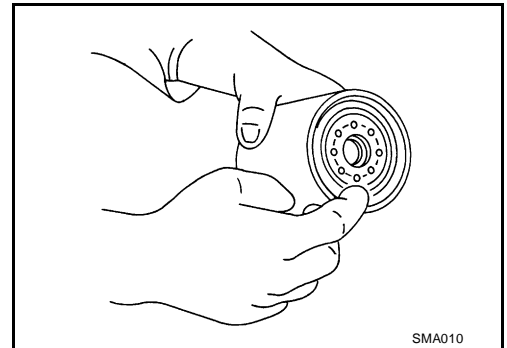

3. Screw oil filter manually until it touches the installation surface, then tighten it by 2/3 turn. Or tighten to specification.

Oil filter:

: 17.6 N·m (1.8 kg-m, 13 ft-lb)

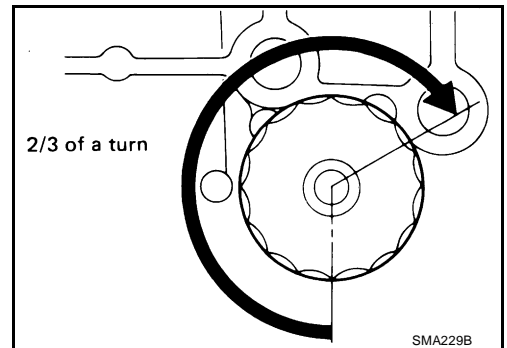

INSPECTION AFTER INSTALLATION

1. Check the engine oil level. Refer to [LU-6, "ENGINE OIL"](#)
2. Start the engine, and there is no leaks of engine oil.
3. Stop engine and wait for 15 minutes.
4. Check engine oil level and adjust the engine oil level. Refer to [LU-6, "ENGINE OIL"](#) .

OIL PUMP

PFP:15010

NBS001PE

OIL PUMP

Removal and Installation

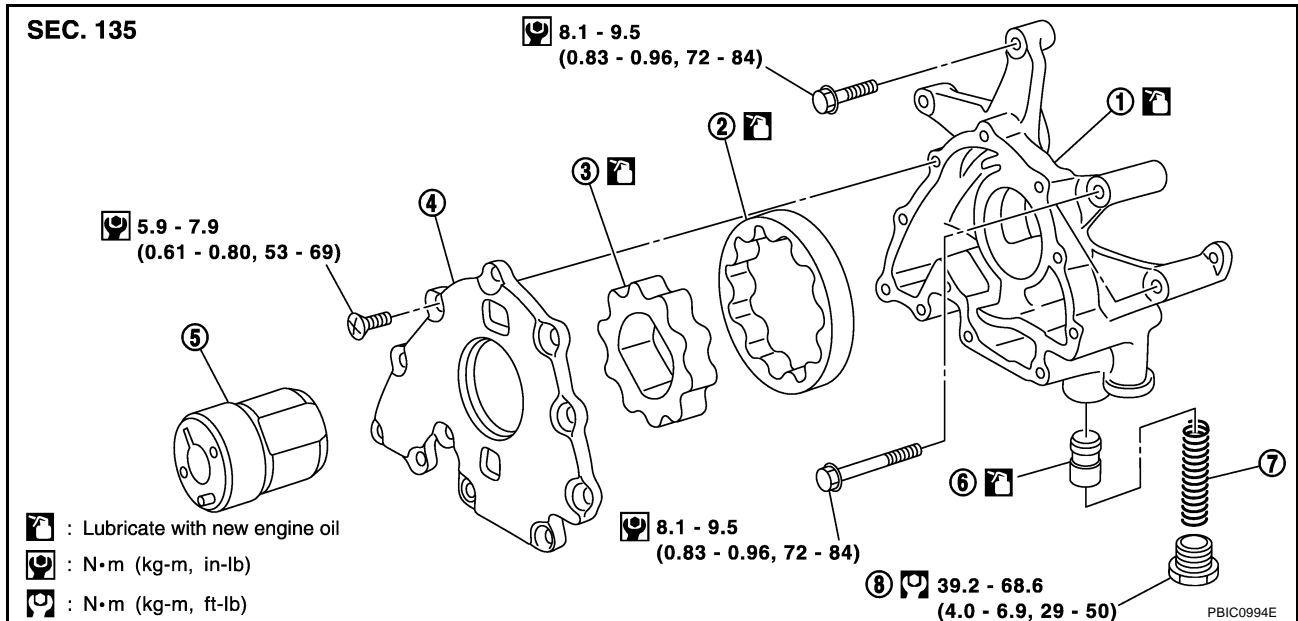

- | | | |
|---------------------|--------------------------|-------------------------|
| 1. Oil pump body | 2. Oil pump outer rotor | 3. Oil pump inner rotor |
| 4. Oil pump cover | 5. Oil pump drive spacer | 6. Regulator valve |
| 7. Regulator spring | 8. Regulator plug | |

REMOVAL

- Remove front cover. Refer to [EM-39, "Removal and Installation"](#).
- Remove oil pump drive spacer.
 - Set bolts in the two bolt holes [M6 x 1.0 mm (0.039 in)] on the front surface. Using a small puller, remove oil pump drive spacer from crankshaft.

NOTE:

The dimension between the centers of the two bolt holes is 33 mm (1.30 in).

In the figure, the commercial steering puller is used.

- Remove oil pump.

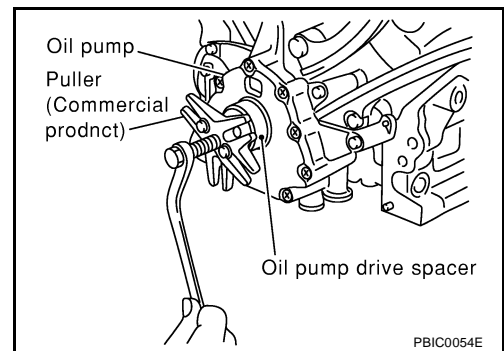

INSTALLATION

- Install oil pump.
- Install oil pump drive spacer as follows.
 - When inserting oil pump drive spacer, align crankshaft key and the flat face of inner rotor.
 - If they are not aligned, rotate inner rotor by hand.
 - Make sure that the each part is aligned. Using a tool such as a plastic hammer, tap lightly until it reaches the end.

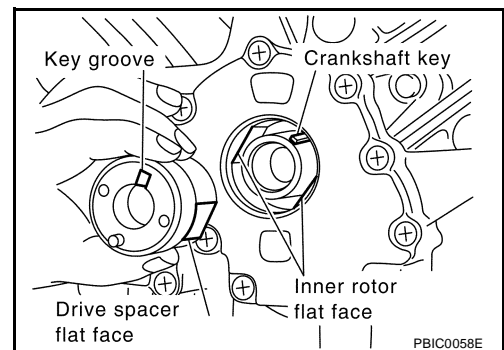

- Install in the reverse order of removal.

INSPECTION AFTER INSTALLATION

- Start engine, and check there is no leak of engine oil.

OIL PUMP

- Check level of engine oil, and adjust engine oil level. Refer to [LU-6, "ENGINE OIL"](#).

Disassembly and Assembly DISASSEMBLY

NBS001PF

1. Remove oil pump cover.
2. Remove oil pump inner rotor and oil pump outer rotor from oil pump body.
3. After removing regulator plug, remove regulator spring and regulator valve.

INSPECTION AFTER DISASSEMBLY

Oil Pump Clearance

- Measure clearance with a feeler gauge.
Clearance between oil pump outer rotor and oil pump body (position 1)

Standard : 0.114 - 0.200 mm (0.0045 - 0.0079 in)

Tip clearance between oil pump inner rotor and oil pump outer rotor (position 2)

Standard : Below 0.180 mm (0.0071in)

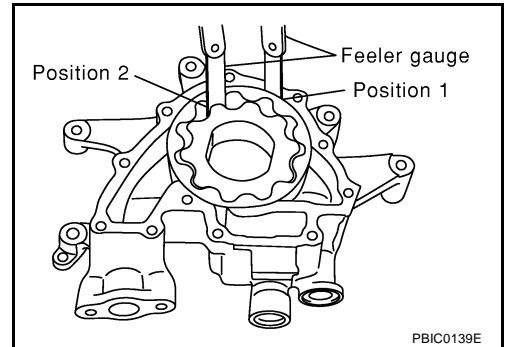

- Measure clearance with a feeler gauge and a straightedge.
Side clearance between oil pump inner rotor and oil pump body (position 3)

Standard : 0.030 - 0.070 mm (0.0012 - 0.0028 in)

Side clearance between oil pump outer rotor and oil pump body (position 4)

Standard : 0.030 - 0.090 mm (0.0012 - 0.0035 in)

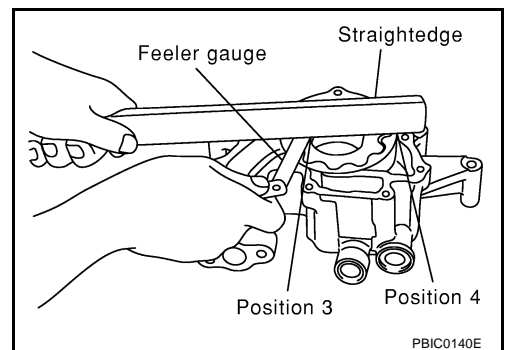

- Calculate the clearance between oil pump inner rotor and oil pump body as follows:
 - Measure the outer diameter of protruded portion of oil pump inner rotor with a micrometer (Position 5)

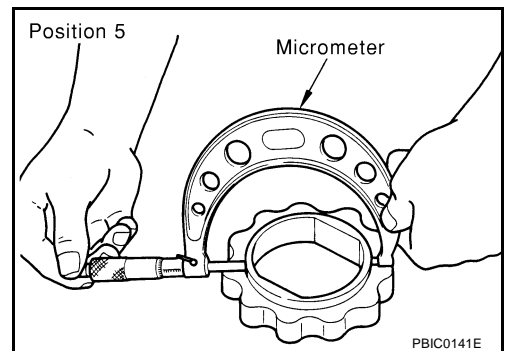

- Measure the inner diameter of oil pump body with an inside micrometer (Position 6)
- (Clearance) = (Oil pump body inner diameter) – (Oil pump inner rotor outer diameter)

Standard : 0.045 - 0.091 mm (0.0018 - 0.0036 in)

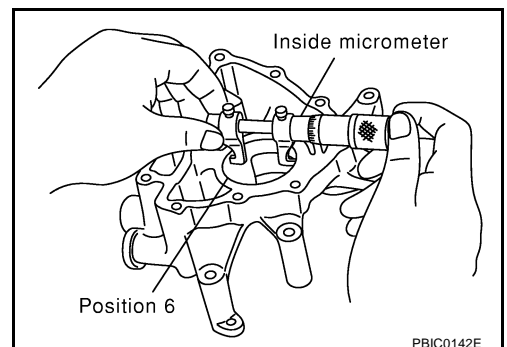

- If out of the standard, replace oil pump assembly.

OIL PUMP

Regulator Valve Clearance

(Clearance) = "D1" (Valve hole diameter) – "D2" (Regulator valve outer diameter)

Standard : 0.040 - 0.097 mm (0.0016 - 0.0038 in)

- If out of the standard, replace oil pump assembly.

CAUTION:

- **Coat regulator valve with engine oil.**
- **Make sure that it falls smoothly into the regulator valve hole by its own weight.**

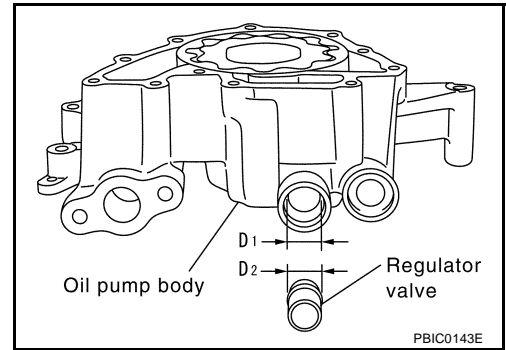

ASSEMBLY

Note the following, and assembly is in the reverse order of disassembly.

- Install oil pump inner rotor and oil pump outer rotor with the punched marks on the oil pump cover side.

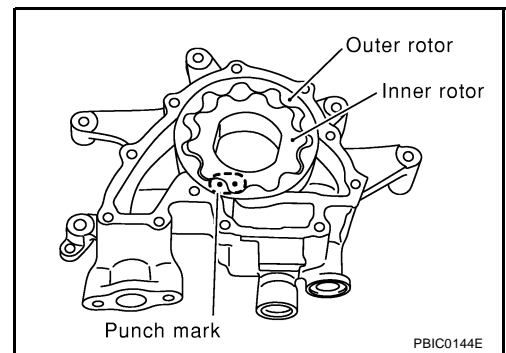

SERVICE DATA AND SPECIFICATIONS (SDS)

SERVICE DATA AND SPECIFICATIONS (SDS)

PFP:00030

Standard and Limit OIL PRESSURE

NBS001PG

Engine speed rpm	Approximate discharge pressure* kPa (kg/cm ² , psi)
Idle speed 2,000	98 (1.0, 14) 294 (3.0, 43)

*: Engine oil temperature at 80°C (176°F)

OIL PUMP

Unit: mm (in)

Oil pump body to oil pump outer rotor radial clearance	0.114 - 0.200 (0.0045 - 0.0079)
Oil pump inner rotor to oil pump outer rotor tip clearance	Below 0.180 (0.0071)
Oil pump body to oil pump inner rotor side clearance	0.030 - 0.070 (0.0012 - 0.0028)
Oil pump body to oil pump outer rotor side clearance	0.030 - 0.090 (0.0012 - 0.0035)
Oil pump inner rotor to oil pump body clearance	0.045 - 0.091 (0.0018 - 0.0036)

REGULATOR VALVE

Unit: mm (in)

Regulator valve to oil pump body clearance	0.040 - 0.097 (0.0016 - 0.0038)
--	---------------------------------

ENGINE OIL CAPACITY

Unit: ℓ (US qt, Imp qt)

With oil filter change	5.6 (5-7/8, 4-7/8)
Without oil filter change	5.0 (5-1/4, 4-3/8)
Dry engine (engine overhaul)	6.7 (7-1/8, 5-7/8)

SERVICE DATA AND SPECIFICATIONS (SDS)
