

A
B
C

SECTION **WW**

WIPER & WASHER

D
E

CONTENTS

<p>PRECAUTION 3</p> <p>PRECAUTIONS 3</p> <p style="padding-left: 20px;">Precaution for Supplemental Restraint System (SRS) "AIR BAG" and "SEAT BELT PRE-TENSIONER"3</p> <p style="padding-left: 20px;">Precaution for Procedure without Cowl Top Cover.....3</p> <p>PREPARATION 4</p> <p>PREPARATION 4</p> <p style="padding-left: 20px;">Commercial Service Tool4</p> <p>SYSTEM DESCRIPTION 5</p> <p>COMPONENT PARTS 5</p> <p style="padding-left: 20px;">Component Parts Location5</p> <p style="padding-left: 20px;">Rain Sensor6</p> <p style="padding-left: 20px;">Washer Switch6</p> <p style="padding-left: 20px;">Front Wiper Motor6</p> <p style="padding-left: 20px;">Washer Level Switch7</p> <p style="padding-left: 20px;">Washer Pump7</p> <p>SYSTEM 8</p> <p>FRONT WIPER AND WASHER SYSTEM (WITH RAIN SENSOR)8</p> <p style="padding-left: 20px;">FRONT WIPER AND WASHER SYSTEM (WITH RAIN SENSOR) : System Description8</p> <p style="padding-left: 20px;">FRONT WIPER AND WASHER SYSTEM (WITH RAIN SENSOR) : Circuit Diagram 12</p> <p style="padding-left: 20px;">FRONT WIPER AND WASHER SYSTEM (WITH RAIN SENSOR) : Fail-safe 12</p> <p>FRONT WIPER AND WASHER SYSTEM (WITHOUT RAIN SENSOR)13</p> <p style="padding-left: 20px;">FRONT WIPER AND WASHER SYSTEM (WITHOUT RAIN SENSOR) : System Description 13</p> <p style="padding-left: 20px;">FRONT WIPER AND WASHER SYSTEM (WITHOUT RAIN SENSOR) : Circuit Diagram 16</p> <p style="padding-left: 20px;">FRONT WIPER AND WASHER SYSTEM (WITHOUT RAIN SENSOR) : Fail-Safe 17</p>	<p style="text-align: right;">F G H I J K WW M N O P</p> <p>INFORMATION DISPLAY (COMBINATION METER)18</p> <p style="padding-left: 20px;">INFORMATION DISPLAY (COMBINATION METER) : Washer Fluid Warning18</p> <p>WARNING/INDICATOR/CHIME LIST19</p> <p style="padding-left: 20px;">WARNING/INDICATOR/CHIME LIST : Warning/Indicator (Information Display) 19</p> <p>DIAGNOSIS SYSTEM (BCM)20</p> <p>COMMON ITEM20</p> <p style="padding-left: 20px;">COMMON ITEM : CONSULT Function (BCM - COMMON ITEM)20</p> <p>WIPER21</p> <p style="padding-left: 20px;">WIPER : CONSULT Function (BCM - WIPER)21</p> <p>DIAGNOSIS SYSTEM (IPDM E/R)24</p> <p style="padding-left: 20px;">Diagnosis Description24</p> <p style="padding-left: 20px;">CONSULT Function (IPDM E/R)26</p> <p>ECU DIAGNOSIS INFORMATION29</p> <p>BCM, IPDM E/R29</p> <p style="padding-left: 20px;">List of ECU Reference29</p> <p>WIRING DIAGRAM30</p> <p>WIPER AND WASHER SYSTEM30</p> <p style="padding-left: 20px;">Wiring Diagram30</p> <p>BASIC INSPECTION35</p> <p>DIAGNOSIS AND REPAIR WORK FLOW35</p> <p style="padding-left: 20px;">Work Flow35</p> <p>DTC/CIRCUIT DIAGNOSIS38</p> <p>FRONT WIPER MOTOR LO CIRCUIT38</p> <p style="padding-left: 20px;">Component Function Check38</p> <p style="padding-left: 20px;">Diagnosis Procedure38</p> <p>FRONT WIPER MOTOR HI CIRCUIT39</p>
--	---

Component Function Check	39	WIPER ARM : Removal and Installation	53
Diagnosis Procedure	39	WIPER ARM : Adjustment	53
FRONT WIPER STOP POSITION SIGNAL		WIPER BLADE	54
CIRCUIT	40	WIPER BLADE : Removal and Installation	54
Component Function Check	40	WIPER REFILL	54
Diagnosis Procedure	40	WIPER REFILL : Removal and Installation	54
FRONT WIPER MOTOR GROUND CIRCUIT ...	41	WIPER DRIVE ASSEMBLY	55
Diagnosis Procedure	41	WIPER DRIVE ASSEMBLY : Removal and Instal-	
RAIN SENSOR	42	lation	56
Component Function Check	42	WIPER DRIVE ASSEMBLY : Disassembly and	
Diagnosis Procedure	42	Assembly	56
WASHER SWITCH	44	FRONT WASHER	57
Component Inspection	44	Exploded View	57
SYMPTOM DIAGNOSIS	45	Hydraulic Layout	58
WIPER AND WASHER SYSTEM SYMPTOMS		WASHER NOZZLE & TUBE	58
...	45	WASHER NOZZLE & TUBE : Removal and Instal-	
WITH RAIN SENSOR	45	lation	58
WITH RAIN SENSOR : Symptom Table	45	WASHER NOZZLE & TUBE : Inspection and Ad-	
WITHOUT RAIN SENSOR	46	justment	59
WITHOUT RAIN SENSOR : Symptom Table	47	WASHER TANK	60
NORMAL OPERATING CONDITION	49	WASHER TANK : Removal and Installation	60
Description	49	WASHER PUMP	61
FRONT WIPER DOES NOT OPERATE	50	WASHER PUMP : Removal and Installation	61
Description	50	WASHER LEVEL SWITCH	62
Diagnosis Procedure	50	WASHER LEVEL SWITCH : Removal and Instal-	
REMOVAL AND INSTALLATION	52	lation	62
FRONT WIPER	52	RAIN SENSOR	63
Exploded View	52	Exploded View	63
WIPER ARM	53	Removal and Installation	63
		Inspection	64
		WIPER AND WASHER SWITCH	65
		Removal and Installation	65

PRECAUTIONS

< PRECAUTION >

PRECAUTION

PRECAUTIONS

Precaution for Supplemental Restraint System (SRS) "AIR BAG" and "SEAT BELT PRE-TENSIONER"

INFOID:000000009238887

The Supplemental Restraint System such as "AIR BAG" and "SEAT BELT PRE-TENSIONER", used along with a front seat belt, helps to reduce the risk or severity of injury to the driver and front passenger for certain types of collision. This system includes seat belt switch inputs and dual stage front air bag modules. The SRS system uses the seat belt switches to determine the front air bag deployment, and may only deploy one front air bag, depending on the severity of a collision and whether the front occupants are belted or unbelted. Information necessary to service the system safely is included in the "SRS AIR BAG" and "SEAT BELT" of this Service Manual.

WARNING:

Always observe the following items for preventing accidental activation.

- To avoid rendering the SRS inoperative, which could increase the risk of personal injury or death in the event of a collision that would result in air bag inflation, all maintenance must be performed by an authorized NISSAN/INFINITI dealer.
- Improper maintenance, including incorrect removal and installation of the SRS, can lead to personal injury caused by unintentional activation of the system. For removal of Spiral Cable and Air Bag Module, see "SRS AIR BAG".
- Never use electrical test equipment on any circuit related to the SRS unless instructed to in this Service Manual. SRS wiring harnesses can be identified by yellow and/or orange harnesses or harness connectors.

PRECAUTIONS WHEN USING POWER TOOLS (AIR OR ELECTRIC) AND HAMMERS

WARNING:

Always observe the following items for preventing accidental activation.

- When working near the Air Bag Diagnosis Sensor Unit or other Air Bag System sensors with the ignition ON or engine running, never use air or electric power tools or strike near the sensor(s) with a hammer. Heavy vibration could activate the sensor(s) and deploy the air bag(s), possibly causing serious injury.
- When using air or electric power tools or hammers, always switch the ignition OFF, disconnect the battery, and wait at least 3 minutes before performing any service.

Precaution for Procedure without Cowl Top Cover

INFOID:000000009238888

When performing the procedure after removing cowl top cover, cover the lower end of windshield with urethane, etc to prevent damage to windshield.

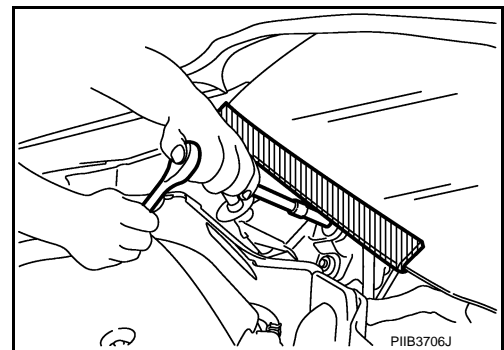

PREPARATION

< PREPARATION >

PREPARATION

PREPARATION

Commercial Service Tool

INFOID:000000009238889

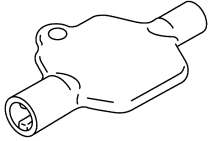
Tool name	Description
<p data-bbox="191 516 431 543">Washer nozzle adjuster</p>  <p data-bbox="776 632 859 646">JSLIA0149ZZ</p>	<p data-bbox="927 449 1425 531">Adjusting washer nozzle. (Available in SEC. 289 of PARTS CATALOG: Part No. 28949 1EA0A)</p> <p data-bbox="927 533 1425 611">NOTE: Washer nozzle adjuster is included with shipment of nozzle.</p>

COMPONENT PARTS

< SYSTEM DESCRIPTION >

SYSTEM DESCRIPTION

COMPONENT PARTS

Component Parts Location

INFOID:000000009728873

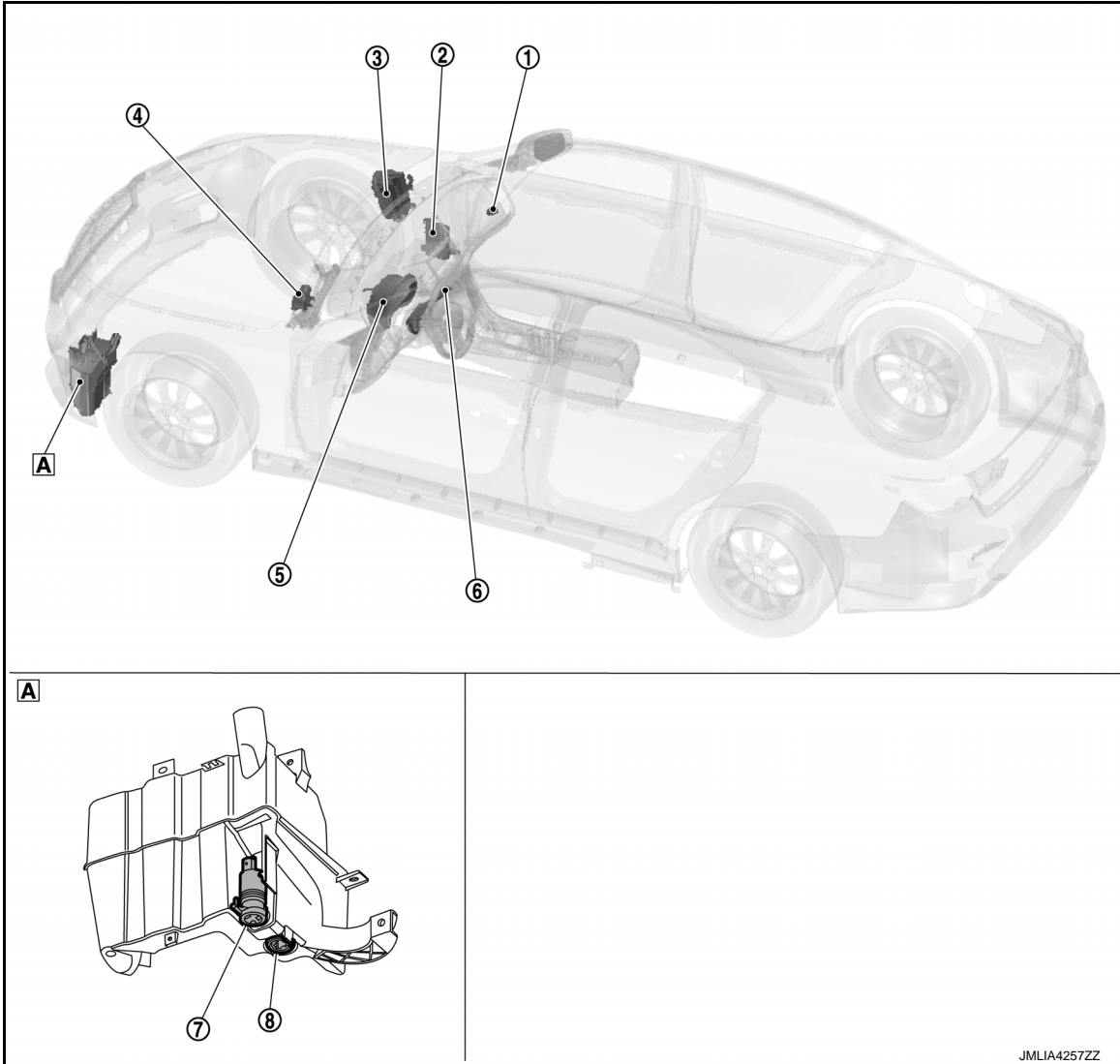

A Behind front fender protector (LH)

No.	Component	Function
①	Rain sensor*	Refer to WW-6, "Rain Sensor" .
②	BCM	<ul style="list-style-type: none"> Judges each switch status by the combination switch reading function. Requests (via CAN communication) the front wiper relay and the front wiper HI/LO relay ON to IPDM E/R. Refer to BCS-4, "BODY CONTROL SYSTEM : Component Parts Location" for detailed installation location.
③	IPDM E/R	<ul style="list-style-type: none"> Controls integrated relays according to the request (via CAN communication) from BCM. Performs the auto stop control of front wiper. Refer to PCS-4, "Component Parts Location" for detailed installation location.
④	Front wiper motor	Refer to WW-6, "Front Wiper Motor" .
⑤	Combination meter	Transmits vehicle speed signal to BCM via CAN communication.

COMPONENT PARTS

< SYSTEM DESCRIPTION >

No.	Component	Function
⑥	Combination switch (Wiper & washer switch)	<ul style="list-style-type: none"> Combination switch: Transmits the status of the combination switch (wiper and washer) to BCM. Wash switch: Refer to WW-6. "Washer Switch".
⑦	Washer pump	Refer to WW-7. "Washer Pump" .
⑧	Washer level switch	Refer to WW-7. "Washer Level Switch" .

*: With rain sensor

Rain Sensor

INFOID:000000009728874

Detects water droplets on the windshield with infrared rays, and transmits the rain sensor signal to BCM via the rain sensor serial link.

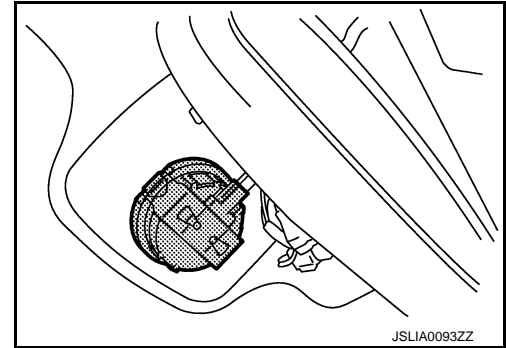

Washer Switch

INFOID:000000009728875

- Washer switch is integrated with combination switch.
- Washer pump is grounded through the combination switch while the washer switch is ON.

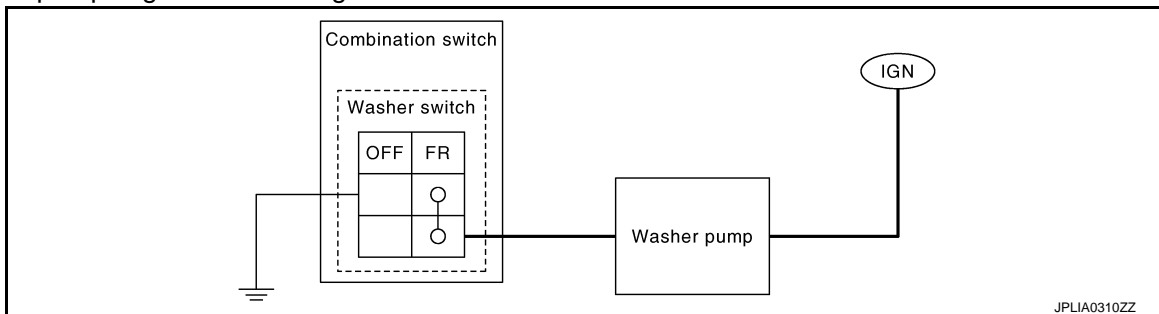

Front Wiper Motor

INFOID:000000009728876

- Controls front wiper operation with IPDM E/R control.
- Transmits front wiper stop position signal to IPDM E/R.

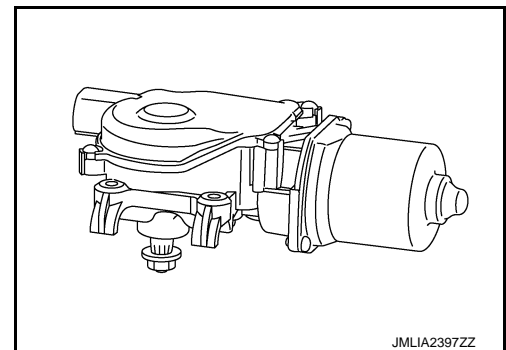

COMPONENT PARTS

< SYSTEM DESCRIPTION >

Washer Level Switch

INFOID:000000009728877

Detects that washer fluid level is low and transmits washer level switch signal to combination meter.

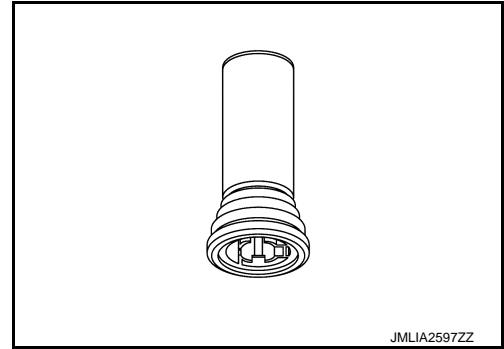

Washer Pump

INFOID:000000009728878

Washer fluid is sprayed according to washer switch states.

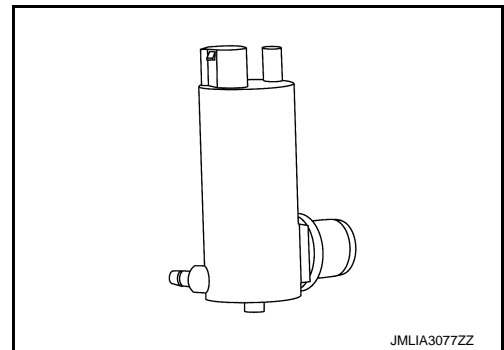

A
B
C
D
E
F
G
H
I
J
K
M
N
O
P

WW

SYSTEM

< SYSTEM DESCRIPTION >

SYSTEM

FRONT WIPER AND WASHER SYSTEM (WITH RAIN SENSOR)

FRONT WIPER AND WASHER SYSTEM (WITH RAIN SENSOR) : System Description

INFOID:000000009728879

SYSTEM DIAGRAM

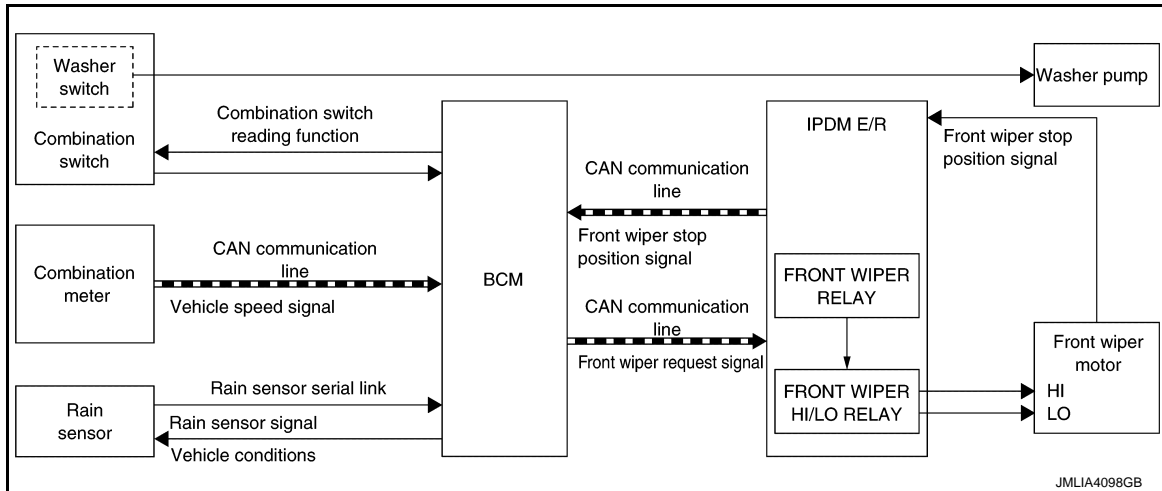

OUTLINE

The front wiper is controlled by each function of BCM and IPDM E/R.

Control by BCM

- Combination switch reading function
- Front wiper control function

Control by IPDM E/R

- Front wiper control function
- Relay control function

FRONT WIPER BASIC OPERATION

- BCM detects the combination switch condition by the combination switch reading function.
- BCM transmits the front wiper request signal to IPDM E/R via CAN communication depending on each operating condition of the front wiper.
- IPDM E/R turns ON/OFF the integrated front wiper relay and the front wiper HI/LO relay according to the front wiper request signal. IPDM E/R provides the power supply to operate the front wiper HI/LO operation.

FRONT WIPER LO OPERATION

- BCM transmits the front wiper request signal (LO) to IPDM E/R via CAN communication according to the front wiper LO operating condition.

Front wiper LO operating condition

- Ignition switch ON
- Front wiper switch LO or front wiper switch MIST (while pressing)
- IPDM E/R turns ON the integrated front wiper relay according to the front wiper request signal (LO).

FRONT WIPER HI OPERATION

- BCM transmits the front wiper request signal (HI) to IPDM E/R via CAN communication according to the front wiper HI operating condition.

Front wiper HI operating condition

- Ignition switch ON
- Front wiper switch HI
- IPDM E/R turns ON the integrated front wiper relay and the front wiper HI/LO relay according to the front wiper request signal (HI).

FRONT WIPER AUTO OPERATION

SYSTEM

< SYSTEM DESCRIPTION >

Rain Detection

Rain level and sensor conditions are detected by rain sensor.

- BCM transmits the vehicle conditions (vehicle speed, front wiper condition, rain sensor sensitivity setting, etc.) to the rain sensor via the rain sensor serial link.
- Rain sensor judges a wiping speed for front wiper by rain condition and the vehicle conditions. And it transmits the wiping speed request signal to the BCM via the rain sensor serial link.

Auto Wiping Operation

- BCM receives the wiping speed request signal from the rain sensor via the rain sensor serial link.
- BCM controls front wiper operation according to the wiping speed request signal. And it transmits the front wiper request signal (LO or HI) to the IPDM E/R via CAN communication line.

Front wiper AUTO operating condition

- Ignition switch ON
- Front wiper switch AUTO

NOTE:

When the front wiper switch is turned to AUTO position, front wiper operates once regardless of rainy conditions.

Rain Sensor Sensitivity Setting

BCM determines rain sensor sensitivity according to wiper volume dial position.

Wiper volume dial position	Sensitivity
6,7	High sensitivity
4,5	Medium-high sensitivity
2,3	Low-medium sensitivity
1	Low sensitivity

NOTE:

Factory setting of the rain sensor operation is operation linked with rain sensor. Rain sensor operation can be set to operation linked or not linked with rain sensor using CONSULT. Refer to [WW-21, "WIPER : CONSULT Function \(BCM - WIPER\)"](#).

NOTE:

When the wiper volume dial position is turned up by 1 level under front wiper AUTO operating condition, front wiper operates once.

Splash mode operation

Front wiper is operated at HI regardless of the wiper volume adjustment position, when water drops are instantaneously sprayed over the windshield glass due to water splash from oncoming vehicles or other causes. After that, AUTO operation is performed depending on the amount of water drops.

SPLASH MODE OPERATION CONDITIONS

- Front wiper switch AUTO
- Ignition switch ON

NOTE:

Splash mode is not operated and auto wiping operation is performed, while the vehicle is stopped.

FRONT WIPER AUTO STOP OPERATION

- BCM stops transmitting the front wiper request signal when the front wiper switch is turned OFF.
- IPDM E/R detects the front wiper stop position signal from the front wiper motor to find out the front wiper motor position (stop position/except stop position).

A
B
C
D
E
F
G
H
I
J
K
M
N
O
P

WW

SYSTEM

< SYSTEM DESCRIPTION >

- When the front wiper request signal is stopped, IPDM E/R turns ON the front wiper relay until the front wiper motor returns to the stop position.

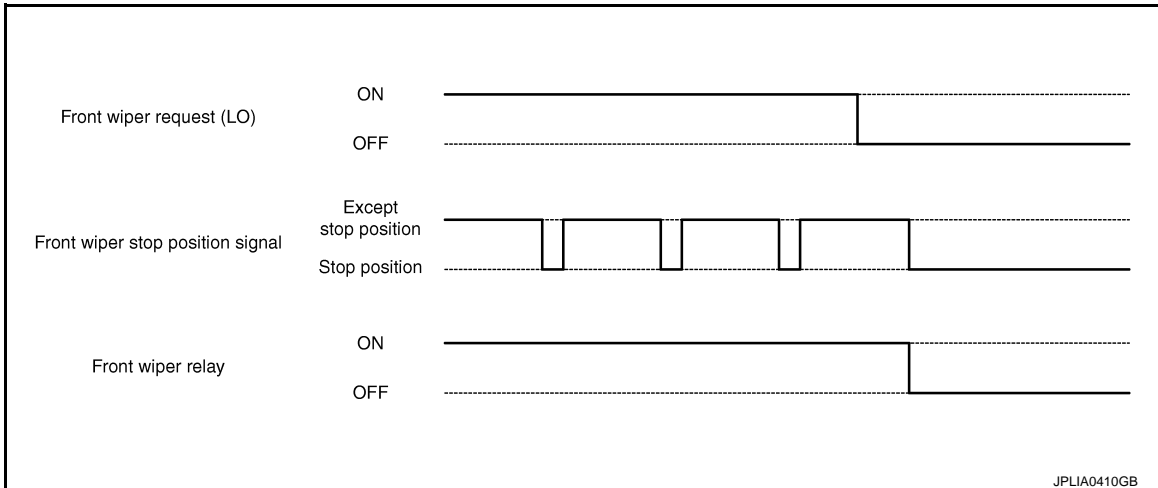

NOTE:

- BCM stops the transmitting of the front wiper request signal when the ignition switch is OFF.
- When the ignition switch is OFF, IPDM E/R turns front wiper relay OFF after front wiper is back to stop position.

FRONT WIPER OPERATION LINKED WITH WASHER

- BCM transmits the front wiper request signal (LO) to IPDM E/R via CAN communication according to the washer linked operating condition of the front wiper.
- BCM transmits the front wiper request signal (LO) so that the front wiper operates approximately 2 times when the front washer switch OFF is detected.

Washer linked operating condition of front wiper

- Ignition switch ON
- Front washer switch ON (0.4 second or more)
- IPDM E/R turns ON the integrated front wiper relay according to the front wiper request signal (LO).
- The washer pump is grounded through the combination switch with the front washer switch ON.

FRONT WIPER DROP WIPE OPERATION

- BCM controls the front wiper to operate once according to the conditions of front wiper drop wipe operation.

Front wiper drop wipe operating condition

- Ignition switch ON
- Front wiper switch OFF
- Front washer switch OFF
- BCM transmits the front wiper request signal (LO) to IPDM E/R via CAN communication so that the front wiper operates once 3 seconds after front wiper operation linked with washer.
- IPDM E/R turns ON the integrated front wiper relay according to the front wiper request signal (LO).

NOTE:

Factory setting of the front wiper drop wipe operation is ON. Front wiper drop wipe operation can be set to ON or OFF using CONSULT. Refer to [WW-21, "WIPER : CONSULT Function \(BCM - WIPER\)"](#).

FRONT WIPER SERVICE POSITION OPERATION

When front wiper switch MIST is operated 2 times, front wiper operates at LO and stops so that front wiper can be locked back without interfere the hood.

During Ignition Switch Is On

Front wiper operates at LO and stops if all following conditions are satisfied.

- Front wiper switch OFF
- Front wiper is in stop position
- Vehicle speed is 4 km/h or less
- Front wiper switch MIST is operated 2 times (Within 0.47 second)

Front wiper returns to stop position when front wiper switch is operated.

Within 1 Minute After Turning Ignition Switch Off

Front wiper operates at LO and stops if all following conditions are satisfied.

- Front wiper switch OFF

SYSTEM

< SYSTEM DESCRIPTION >

- Front wiper is in stop position
 - Front wiper switch MIST is operated 2 times (Within 0.47 second)
- Front wiper returns to stop position when front wiper switch is operated. (If 1 minute or more is passed after turning ignition switch OFF, front wiper returns to stop position when ignition switch is turned ON and front wiper switch is operated.)

WIPER LINKED AUTO LIGHTING FUNCTION

When lighting switch is in the AUTO position, front wiper operates, and then headlamp ON. Refer to [EXL-18, "AUTO LIGHT SYSTEM : System Description"](#).

A
B
C
D
E
F
G
H
I
J
K
M
N
O
P

WW

SYSTEM

< SYSTEM DESCRIPTION >

FRONT WIPER AND WASHER SYSTEM (WITH RAIN SENSOR) : Circuit Diagram

INFOID:000000009728880

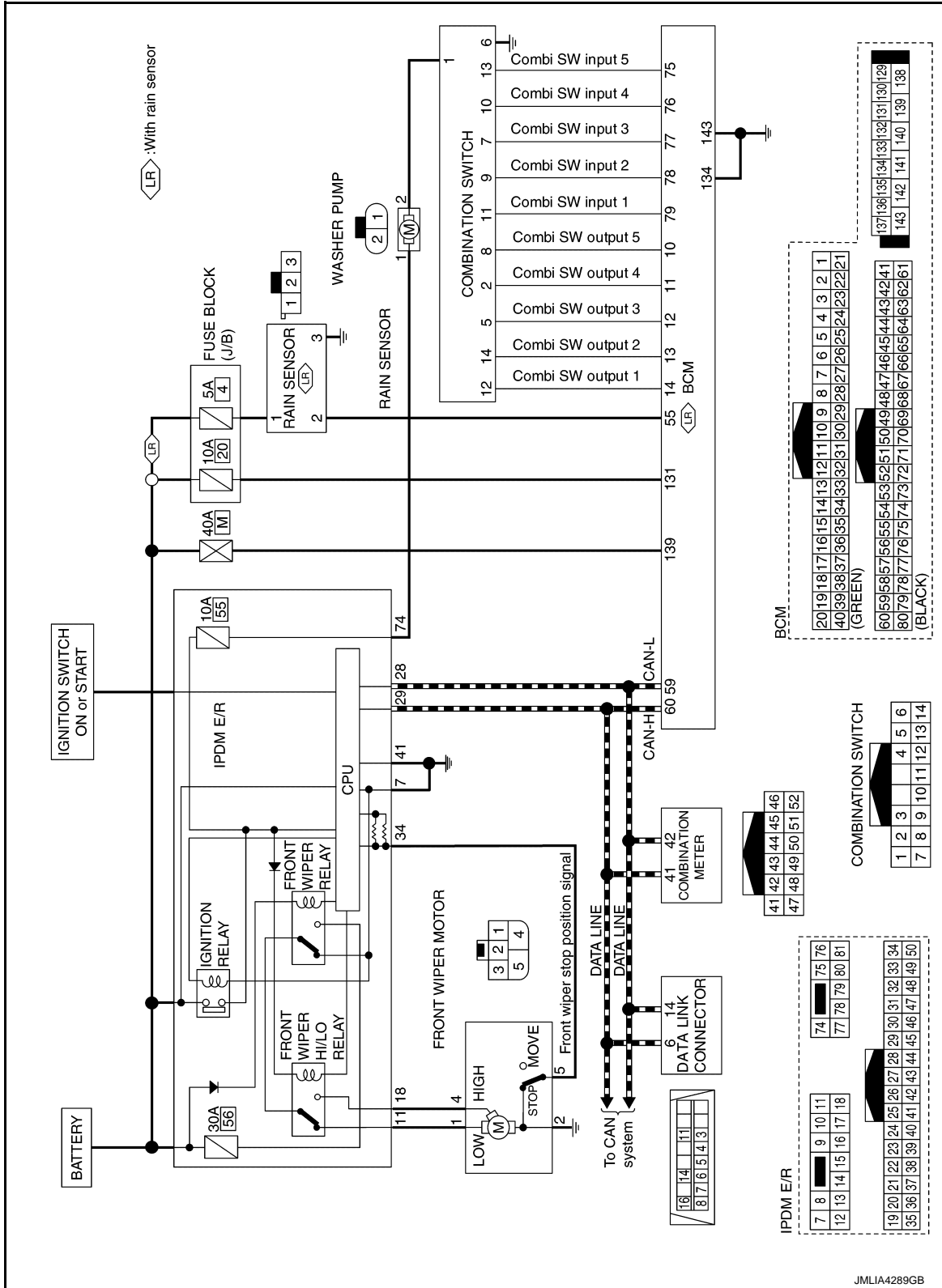

JMLIA4289GB

FRONT WIPER AND WASHER SYSTEM (WITH RAIN SENSOR) : Fail-safe

INFOID:000000009728881

IPDM E/R

If No CAN Communication Is Available With BCM

SYSTEM

< SYSTEM DESCRIPTION >

When CAN communication with ECM and BCM is impossible, IPDM E/R performs fail-safe control. After CAN communication recovers normally, it also returns to normal control.

Control part	Fail-safe operation
Front wiper motor	<ul style="list-style-type: none"> The status just before activation of fail-safe control is maintained until the ignition switch is turned OFF while the front wiper is operating at LO or HI speed. The wiper is operated at LO speed until the ignition switch is turned OFF if the fail-safe control is activated while the front wiper is set in the INT mode and the front wiper motor is operating. Returns automatically wiper to stop position when ignition switch is turned ON if fail-safe control is activated while front wiper motor is operated and wiper stop in the other position than stop position. The status is held at service position if the fail-safe control is activated while the service position function is operating.

Front Wiper Protection Function

IPDM E/R detects front wiper stop position by a front wiper stop position signal.

When a front wiper stop position signal is in the conditions listed below, IPDM E/R stops power supply to wiper after repeating a front wiper 10 seconds activation and 20 seconds stop.

Ignition switch	Front wiper switch	Front wiper stop position signal
ON	OFF	The front wiper stop position signal (stop position) can not be input for 10 seconds.
	ON	The front wiper stop position signal does not change for 10 seconds.

NOTE:

This operation status can be confirmed on the IPDM E/R "Data Monitor" that displays "BLOCK" for the item "WIP PROT" while the wiper is stopped.

BCM

Fail-safe Control By Rain Sensor Malfunction

BCM detects the rain sensor serial link error and the rain sensor malfunction.

BCM controls the following fail-safe when rain sensor has a malfunction.

- Front wiper switch AUTO and sensing rain drop: The condition just before the activation of fail-safe is maintained until the front wiper switch is turned OFF.
- Front wiper switch AUTO and not sensing rain drop: Front wiper is LO operation until the front wiper switch is turned off.

FRONT WIPER AND WASHER SYSTEM (WITHOUT RAIN SENSOR)

FRONT WIPER AND WASHER SYSTEM (WITHOUT RAIN SENSOR) : System Description

INFOID:000000009728882

SYSTEM DIAGRAM

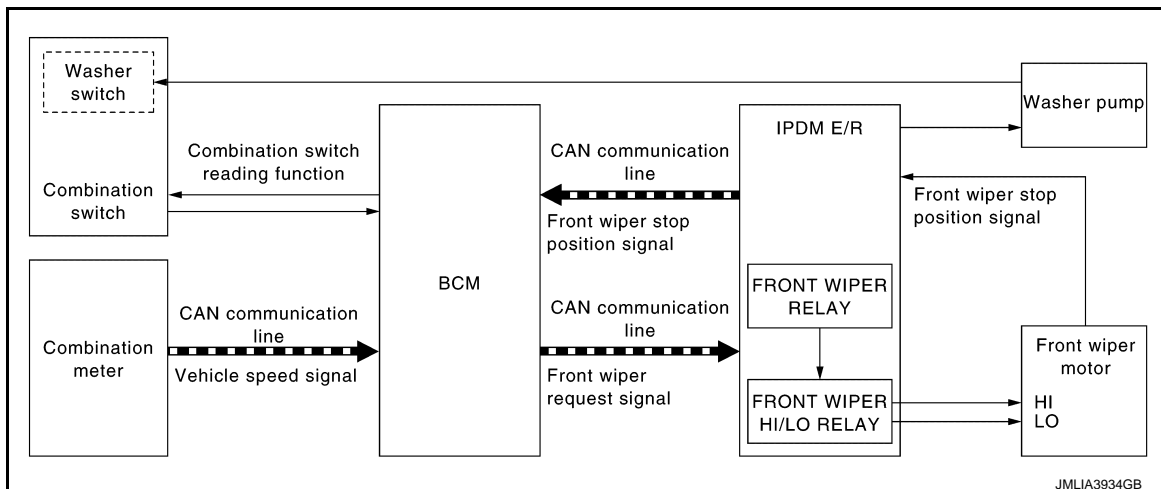

OUTLINE

The front wiper is controlled by each function of BCM and IPDM E/R.

Control by BCM

SYSTEM

< SYSTEM DESCRIPTION >

- Combination switch reading function
- Front wiper control function

Control by IPDM E/R

- Front wiper control function
- Relay control function

FRONT WIPER BASIC OPERATION

- BCM detects the combination switch condition by the combination switch reading function.
- BCM transmits the front wiper request signal to IPDM E/R via CAN communication depending on each operating condition of the front wiper.
- IPDM E/R turns ON/OFF the integrated front wiper relay and the front wiper HI/LO relay according to the front wiper request signal. IPDM E/R provides the power supply to operate the front wiper HI/LO operation.

FRONT WIPER LO OPERATION

- BCM transmits the front wiper request signal (LO) to IPDM E/R via CAN communication according to the front wiper LO operating condition.

Front wiper LO operating condition

- Ignition switch ON
- Front wiper switch LO or front wiper switch MIST (while pressing)
- IPDM E/R turns ON the integrated front wiper relay according to the front wiper request signal (LO).

FRONT WIPER HI OPERATION

- BCM transmits the front wiper request signal (HI) to IPDM E/R via CAN communication according to the front wiper HI operating condition.

Front wiper HI operating condition

- Ignition switch ON
- Front wiper switch HI
- IPDM E/R turns ON the integrated front wiper relay and the front wiper HI/LO relay according to the front wiper request signal (HI).

FRONT WIPER INT OPERATION

- BCM transmits the front wiper request signal (INT) to IPDM E/R via CAN communication depending on the front wiper INT operating condition and intermittent operation delay interval according to the wiper volume dial position.

Front wiper INT operating condition

- Ignition switch ON
- Front wiper switch INT
- IPDM E/R turns ON the integrated front wiper relay so that the front wiper is operated only once according to the front wiper request signal (INT).
- BCM detects stop position/except stop position of the front wiper motor according to the front wiper stop position signal received from IPDM E/R via CAN communication.
- BCM transmits the front wiper request signal (INT) again after the intermittent operation delay interval.

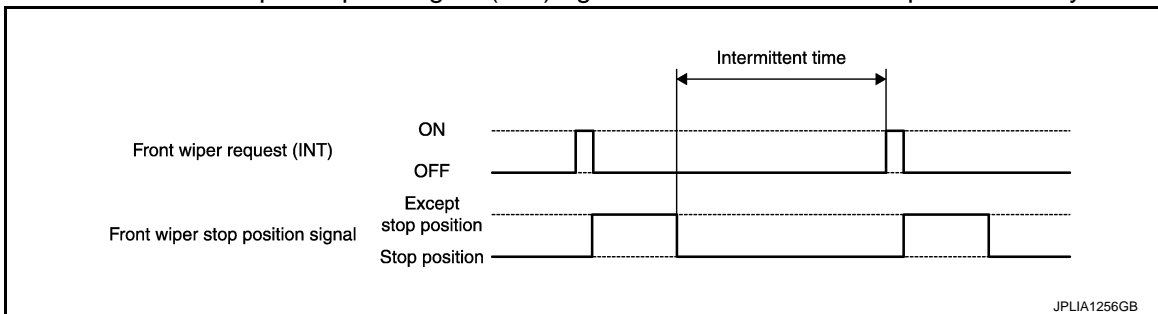

NOTE:

Factory setting of the front wiper intermittent operation is operation not linked with vehicle speed. Front wiper intermittent operation can be set to operation linked or not linked with vehicle speed using CONSULT. Refer to [WW-21, "WIPER : CONSULT Function \(BCM - WIPER\)"](#).

Front wiper intermittent operation with vehicle speed

- BCM calculates the intermittent operation delay interval from the following
 - Vehicle speed signal
 - Wiper volume dial position

SYSTEM

< SYSTEM DESCRIPTION >

Intermittent operation delay Interval

Unit: Second

Wiper volume dial position	Intermittent operation interval	Vehicle speed		
		0 – 5 km/h (0 – 3.1 MPH)	5 – 65 km/h (3.1 – 40.4 MPH)*	65 km/h (40.4 MPH) or more
7	Short ↑	1	0.4	0.24
6		2.5	1	0.6
5		5	2	1.2
4		7.5	3	1.8
3	↓ Long	12.5	5	3
2		25	10	6
1		40	16	9.6

*: When operation setting is not linked with vehicle speed.

FRONT WIPER AUTO STOP OPERATION

- BCM stops transmitting the front wiper request signal when the front wiper switch is turned OFF.
- IPDM E/R detects the front wiper stop position signal from the front wiper motor and detects the front wiper motor position (stop position/except stop position).
- When the front wiper request signal is stopped, IPDM E/R turns ON the front wiper relay until the front wiper motor returns to the stop position.

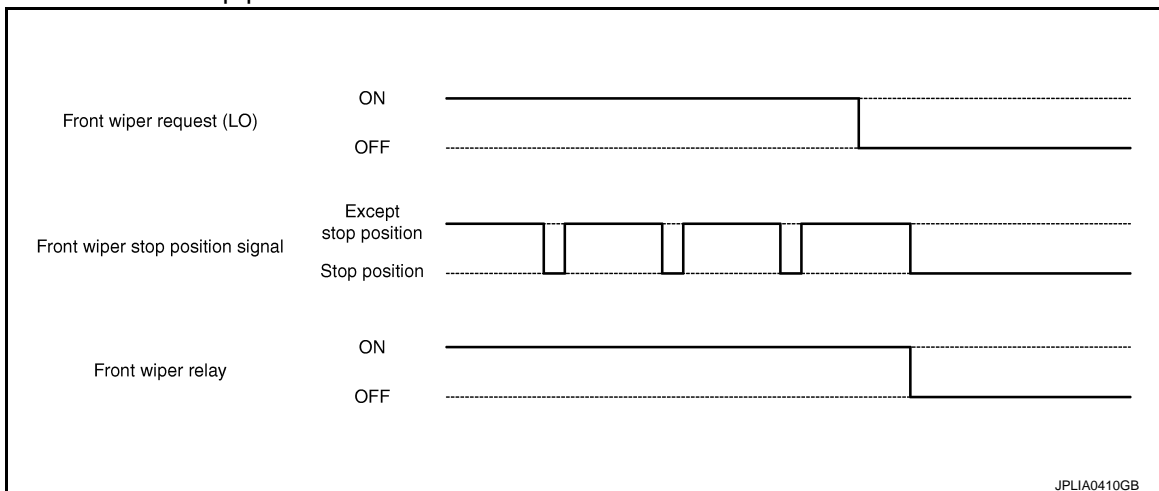

NOTE:

- BCM stops the transmitting of the front wiper request signal when the ignition switch is OFF.
- When the ignition switch is OFF, IPDM E/R turns front wiper relay OFF after front wiper is back to stop position.

FRONT WIPER OPERATION LINKED WITH WASHER

- BCM transmits the front wiper request signal (LO) to IPDM E/R via CAN communication according to the washer linked operating condition of the front wiper.
- BCM transmits the front wiper request signal (LO) so that the front wiper operates approximately 2 times when the front washer switch OFF is detected.

Washer linked operating condition of front wiper

- Ignition switch ON
- Front washer switch ON (0.4 second or more)
- IPDM E/R turns ON the integrated front wiper relay according to the front wiper request signal (LO).
- The washer pump is grounded through the combination switch with the front washer switch ON.

FRONT WIPER DROP WIPE OPERATION

- BCM controls the front wiper to operate once according to the conditions of front wiper drop wipe operation.

Front wiper drop wipe operating condition

- Ignition switch ON
- Front wiper switch OFF
- Front washer switch OFF

SYSTEM

< SYSTEM DESCRIPTION >

- BCM transmits the front wiper request signal (LO) to IPDM E/R via CAN communication so that the front wiper operates once 3 seconds after front wiper operation linked with washer.
- IPDM E/R turns ON the integrated front wiper relay according to the front wiper request signal (LO).

NOTE:

Factory setting of the front wiper drop wipe operation is ON. Front wiper drop wipe operation can be set to ON or OFF using CONSULT. Refer to [WW-21, "WIPER : CONSULT Function \(BCM - WIPER\)"](#).

FRONT WIPER SERVICE POSITION OPERATION

When front wiper switch MIST is operated 2 times, front wiper operates at LO and stops so that front wiper can be locked back without interfere the hood.

During Ignition Switch Is On

Front wiper operates at LO and stops if all following conditions are satisfied.

- Front wiper switch OFF
- Front wiper is in stop position
- Vehicle speed is 4 km/h or less
- Front wiper switch MIST is operated 2 times (Within 0.47 second)

Front wiper returns to stop position when front wiper switch is operated.

Within 1 Minute After Turning Ignition Switch Off

Front wiper operates at LO and stops if all following conditions are satisfied.

- Front wiper switch OFF
- Front wiper is in stop position
- Front wiper switch MIST is operated 2 times (Within 0.47 second)

Front wiper returns to stop position when front wiper switch is operated. (If 1 minute or more is passed after turning ignition switch OFF, front wiper returns to stop position when ignition switch is turned ON and front wiper switch is operated.)

WIPER LINKED AUTO LIGHTING FUNCTION

When lighting switch is in the AUTO position, front wiper operates, and then headlamp ON. Refer to [EXL-18, "AUTO LIGHT SYSTEM : System Description"](#).

FRONT WIPER AND WASHER SYSTEM (WITHOUT RAIN SENSOR) : Circuit Dia-

SYSTEM

< SYSTEM DESCRIPTION >

gram

INFOID:000000009728884

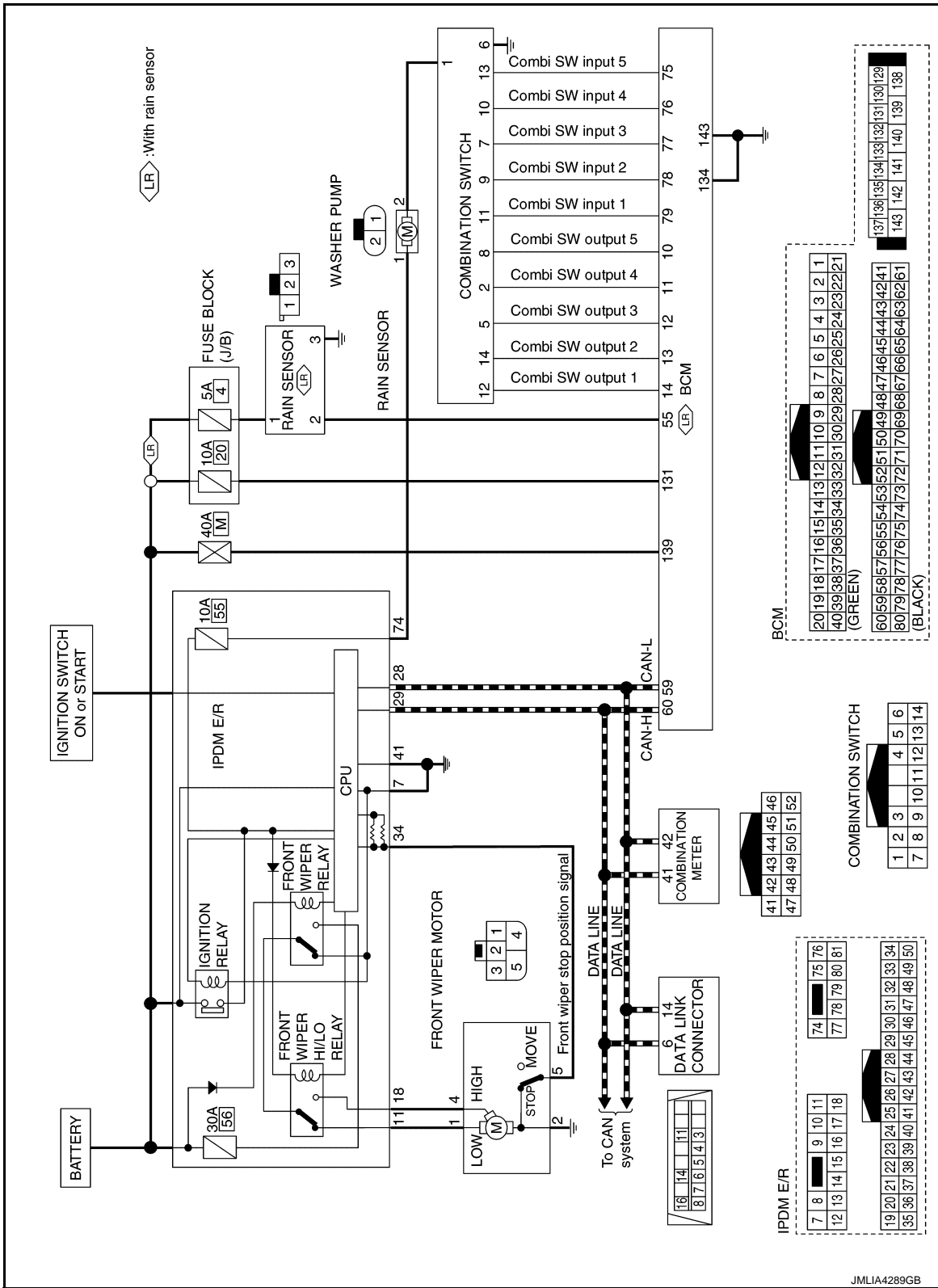

FRONT WIPER AND WASHER SYSTEM (WITHOUT RAIN SENSOR) : Fail-Safe

INFOID:000000009728884

IPDM E/R

If No CAN Communication Is Available With BCM

A
B
C
D
E
F
G
H
I
J
K
L
M
N
O
P



SYSTEM

< SYSTEM DESCRIPTION >

When CAN communication with ECM and BCM is impossible, IPDM E/R performs fail-safe control. After CAN communication recovers normally, it also returns to normal control.

Control part	Fail-safe operation
Front wiper motor	<ul style="list-style-type: none"> • The status just before activation of fail-safe control is maintained until the ignition switch is turned OFF while the front wiper is operating at LO or HI speed. • The wiper is operated at LO speed until the ignition switch is turned OFF if the fail-safe control is activated while the front wiper is set in the INT mode and the front wiper motor is operating. • Returns automatically wiper to stop position when ignition switch is turned ON if fail-safe control is activated while front wiper motor is operated and wiper stop in the other position than stop position. • The status is held at service position if the fail-safe control is activated while the service position function is operating.

Front Wiper Protection Function

IPDM E/R detects front wiper stop position by a front wiper stop position signal.

When a front wiper stop position signal is in the conditions listed below, IPDM E/R stops power supply to wiper after repeating a front wiper 10 seconds activation and 20 seconds stop.

Ignition switch	Front wiper switch	Front wiper stop position signal
ON	OFF	The front wiper stop position signal (stop position) can not be input for 10 seconds.
	ON	The front wiper stop position signal does not change for 10 seconds.

NOTE:

This operation status can be confirmed on the IPDM E/R “Data Monitor” that displays “BLOCK” for the item “WIP PROT” while the wiper is stopped.

INFORMATION DISPLAY (COMBINATION METER)

INFORMATION DISPLAY (COMBINATION METER) : Washer Fluid Warning

INFOID:000000009728885

DESIGN/PURPOSE

Washer fluid warning reminds driver the washer fluid is insufficient.

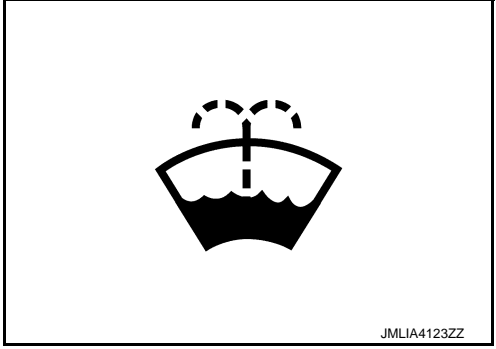
Symbol	Message
	Low Washer Fluid

SYNCHRONIZATION WITH MASTER WARNING LAMP

Not applicable

SYSTEM

< SYSTEM DESCRIPTION >

SYSTEM DIAGRAM

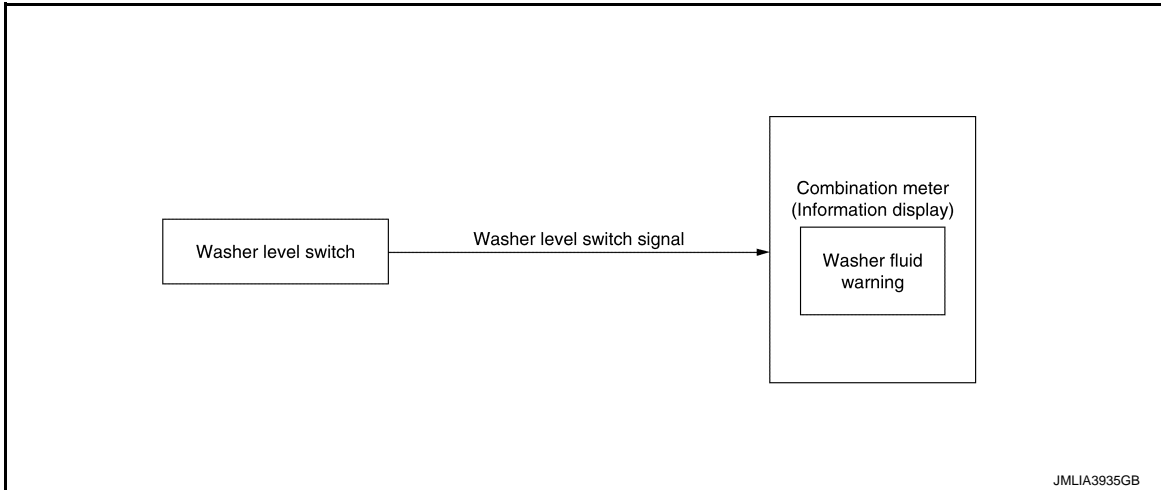

SIGNAL PATH

- When washer fluid level is low, washer level switch turns ON and transmits washer level switch signal to combination meter.
- Combination meter display washer fluid warning according to washer level switch signal.

WARNING/INDICATOR OPERATING CONDITION

When all of the conditions listed below are satisfied:

- Ignition switch is ON.
- Washer fluid is insufficient. (Washer level switch is ON and 3 minutes are passed)

WARNING/INDICATOR CANCEL CONDITION

When any of the condition listed below is satisfied:

- Ignition switch is OFF.
- After refill the washer fluid. (Washer level switch is OFF and 30 seconds are passed)

TIMING CHART

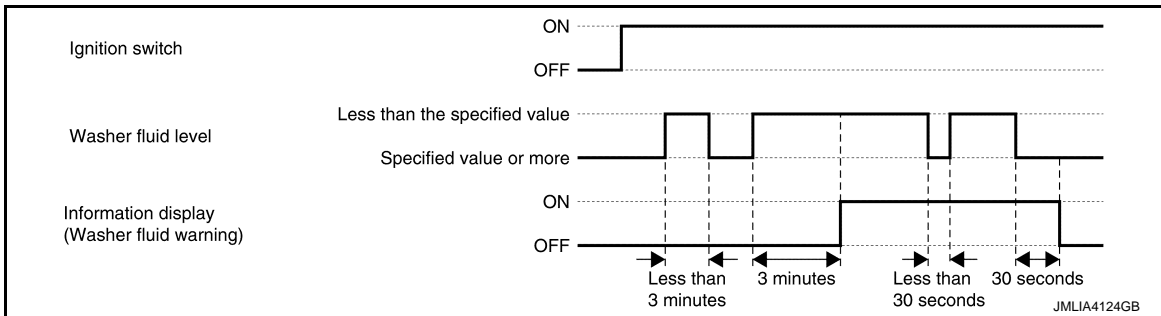

WARNING/INDICATOR/CHIME LIST

WARNING/INDICATOR/CHIME LIST : Warning/Indicator (Information Display)

INFOID:000000009809103

Item	Reference
Washer fluid warning	Refer to WW-18, "INFORMATION DISPLAY (COMBINATION METER) : Washer Fluid Warning" .

DIAGNOSIS SYSTEM (BCM)

< SYSTEM DESCRIPTION >

DIAGNOSIS SYSTEM (BCM)

COMMON ITEM

COMMON ITEM : CONSULT Function (BCM - COMMON ITEM)

INFOID:000000009238895

APPLICATION ITEM

CONSULT performs the following functions via CAN communication with BCM.

Diagnosis mode	Function Description
Work Support	Changes the setting for each system function.
Self Diagnostic Result	Displays the diagnosis results judged by BCM.
CAN Diag Support Monitor	Monitors the reception status of CAN communication viewed from BCM.
Data Monitor	The BCM input/output signals are displayed.
Active Test	The signals used to activate each device are forcibly supplied from BCM.
Ecu Identification	The BCM part number is displayed.
Configuration	<ul style="list-style-type: none"> Read and save the vehicle specification. Write the vehicle specification when replacing BCM.

SYSTEM APPLICATION

BCM can perform the following functions for each system.

NOTE:

It can perform the diagnosis modes except the following for all sub system selection items.

×: Applicable item

System	Sub system selection item	Diagnosis mode		
		Work Support	Data Monitor	Active Test
Door lock	DOOR LOCK	×	×	×
Rear window defogger	REAR DEFOGGER	×	×	×
Warning chime	BUZZER		×	×
Interior room lamp timer	INT LAMP	×	×	×
Exterior lamp	HEAD LAMP	×	×	×
Wiper and washer	WIPER	×	×	×
Turn signal and hazard warning lamps	FLASHER	×	×	×
—	AIR CONDITONER*		×	×
<ul style="list-style-type: none"> Intelligent Key system Engine start system 	INTELLIGENT KEY	×	×	×
Combination switch	COMB SW		×	
Body control system	BCM	×		
IVIS - NATS	IMMU	×	×	×
Interior room lamp battery saver	BATTERY SAVER	×	×	×
Trunk lid open	TRUNK		×	
Vehicle security system	THEFT ALM	×	×	×
RAP system	RETAINED PWR		×	
Signal buffer system	SIGNAL BUFFER		×	×
TPMS	AIR PRESSURE MONITOR			×

*: This item is not used.

FREEZE FRAME DATA (FFD)

The BCM records the following vehicle condition at the time a particular DTC is detected, and displays on CONSULT.

DIAGNOSIS SYSTEM (BCM)

< SYSTEM DESCRIPTION >

CONSULT screen item	Indication/Unit	Description	
Vehicle Speed	km/h	Vehicle speed of the moment a particular DTC is detected	
Odo/Trip Meter	km	Total mileage (Odometer value) of the moment a particular DTC is detected	
Vehicle Condition	SLEEP>LOCK	Power position status of the moment a particular DTC is detected*	While turning BCM status from low power consumption mode to normal mode (Power supply position is "LOCK"*)
	SLEEP>OFF		While turning BCM status from low power consumption mode to normal mode (Power supply position is "OFF".)
	LOCK>ACC		While turning power supply position from "LOCK" *to "ACC"
	ACC>ON		While turning power supply position from "ACC" to "IGN"
	RUN>ACC		While turning power supply position from "RUN" to "ACC" (Vehicle is stopping and selector lever is except P position.)
	CRANK>RUN		While turning power supply position from "CRANKING" to "RUN" (From cranking up the engine to run it)
	RUN>URGENT		While turning power supply position from "RUN" to "ACC" (Emergency stop operation)
	ACC>OFF		While turning power supply position from "ACC" to "OFF"
	OFF>LOCK		While turning power supply position from "OFF" to "LOCK"*
	OFF>ACC		While turning power supply position from "OFF" to "ACC"
	ON>CRANK		While turning power supply position from "IGN" to "CRANKING"
	OFF>SLEEP		While turning BCM status from normal mode (Power supply position is "OFF".) to low power consumption mode
	LOCK>SLEEP		While turning BCM status from normal mode (Power supply position is "LOCK"*.) to low power consumption mode
	LOCK		Power supply position is "LOCK" (Ignition switch OFF)*
	OFF		Power supply position is "OFF" (Ignition switch OFF)
	ACC		Power supply position is "ACC" (Ignition switch ACC)
	ON		Power supply position is "IGN" (Ignition switch ON with engine stopped)
ENGINE RUN	Power supply position is "RUN" (Ignition switch ON with engine running)		
CRANKING	Power supply position is "CRANKING" (At engine cranking)		
IGN Counter	0 - 39	The number of times that ignition switch is turned ON after DTC is detected <ul style="list-style-type: none"> • The number is 0 when a malfunction is detected now. • The number increases like 1 → 2 → 3...38 → 39 after returning to the normal condition whenever ignition switch OFF → ON. • The number is fixed to 39 until the self-diagnosis results are erased if it is over 39. 	

NOTE:

*: Power supply position shifts to "LOCK" from "OFF", when ignition switch is in the OFF position, selector lever is in the P position, and any of the following conditions are met.

- Closing door
- Opening door
- Door is locked using door request switch
- Door is locked using Intelligent Key

The power supply position shifts to "ACC" when the push-button ignition switch (push switch) is pushed at "LOCK".

WIPER

WIPER : CONSULT Function (BCM - WIPER)

INFOID:000000009658779

WORK SUPPORT

DIAGNOSIS SYSTEM (BCM)

< SYSTEM DESCRIPTION >

Service item	Setting item	Description	
RAIN SENSOR*1	On*3	With rain sensor (Front wiper intermittent time linked with the rain sensor, vehicle speed, and AUTO dial position)	The setting of front wiper AUTO operation can be changed
	Off	Without rain sensor (Front wiper intermittent time linked with the vehicle speed and AUTO dial position)	
WIPER SPEED SETTING*2	On	Linked with vehicle speed (Front wiper intermittent time linked with the vehicle speed and wiper intermittent dial position.)	The setting of front wiper INT operation can be changed.
	Off*3	Not linked with vehicle speed (Front wiper intermittent time linked with the wiper intermittent dial position.)	
FR RR DRIP	On*3	Front wiper drop wipe ON	The setting of drop wipe operation can be changed
	Off	Front wiper drop wipe OFF	

*1: With rain sensor

*2: Without rain sensor

*3: Factory setting

DATA MONITOR

NOTE:

The following table includes information (items) inapplicable to this vehicle. For information (items) applicable to this vehicle, refer to CONSULT display items.

Monitor Item [Unit]	Description
PUSH SW [Off/On]	The switch status input from push-button ignition switch.
VEH SPEED 1 [km/h]	Displays the value of the vehicle speed signal received from combination meter via CAN communication.
FR WIPER HI [Off/On]	Status of each switch judged by BCM using the combination switch reading function
FR WIPER LOW [Off/On]	
FR WASHER SW [Off/On]	
FR WIPER INT [Off/On]	
FR WIPER STOP [Off/On]	Displays the status of the front wiper position signal received from IPDM E/R via CAN communication.
INT VOLUME [1 – 7]	Status of each switch judged by BCM using the combination switch reading function
RR WIPER ON [Off/On]	NOTE: The item is indicated, but not monitored.
RR WIPER INT [Off/On]	NOTE: The item is indicated, but not monitored.
RR WASHER SW [Off/On]	NOTE: The item is indicated, but not monitored.
RR WIPER STOP [Off/On]	NOTE: The item is indicated, but not monitored.
H/L WSR SW [Off/On]	NOTE: This item is indicated, but not monitored
RAIN SENSOR* [OFF/LOW/HIGH/SPLASH/NG]	Request signal from rain sensor detected by BCM is displayed

DIAGNOSIS SYSTEM (BCM)

< SYSTEM DESCRIPTION >

*: For models without rain sensor, this item is displayed, but can not be monitored.

ACTIVE TEST

Test item	Operation	Description
FR WIPER	Hi	Transmits the front wiper request signal (HI) to IPDM E/R via CAN communication to operate the front wiper HI operation.
	Lo	Transmits the front wiper request signal (LO) to IPDM E/R via CAN communication to operate the front wiper LO operation.
	INT	Transmits the front wiper request signal (INT) to IPDM E/R via CAN communication to operate the front wiper INT operation.
	Off	Stops transmitting the front wiper request signal to stop the front wiper operation.
RR WIPER	NOTE: The item is indicated, but not used.	
HEADLAMP WASHER	NOTE: The item is indicated, but not used.	

A
B
C
D
E
F
G
H
I
J
K
M
N
O
P

WW

DIAGNOSIS SYSTEM (IPDM E/R)

< SYSTEM DESCRIPTION >

DIAGNOSIS SYSTEM (IPDM E/R)

Diagnosis Description

INFOID:000000009728919

AUTO ACTIVE TEST

Description

In auto active test mode, the IPDM E/R sends a drive signal to the following systems to check their operation.

- Oil pressure warning lamp
- Front wiper motor
- Parking lamp
- License plate lamp
- Tail lamp
- Side marker lamp
- Front fog lamp
- Headlamp (LO, HI)
- A/C compressor (magnet clutch)
- Cooling fan

Operation Procedure

CAUTION:

Wiper arm interferes with hood when wiper is operated while wiper arm is in the raised position. Always perform auto active test without setting wiper arm in the raised position. Always pour water on front windshield glass in advance to auto active test so that damage on front windshield glass surface is prevented.

NOTE:

Never perform auto active test in the following conditions.

- CONSULT is connected
- Passenger door is open

1. Turn the ignition switch OFF.
2. Turn the ignition switch ON, and within 20 seconds, press the driver door switch 10 times. Then turn the ignition switch OFF.
3. Turn the ignition switch ON within 10 seconds. After that the horn sounds once and the auto active test starts.

NOTE:

Engine starts when ignition switch is turned ON while brake pedal is depressed.

4. Oil pressure warning lamp starts blinking when the auto active test starts.
5. After a series of the following operations is repeated 3 times, auto active test is completed.

NOTE:

- When auto active test mode has to be cancelled halfway through test, turn the ignition switch OFF.
- When auto active test is not activated, door switch may be the cause. Check door switch. Refer to [DLK-111, "Component Function Check"](#).

Inspection in Auto Active Test Mode

When auto active test mode is actuated, the following operation sequence is repeated 3 times.

Operation sequence	Inspection location	Operation
1	Oil pressure warning lamp	Blinks continuously during of auto active test
2	Front wiper motor	LO for 5 seconds → HI for 5 seconds
3	<ul style="list-style-type: none">• Parking lamp• License plate lamp• Tail lamp• Side marker lamp• Front fog lamp	10 seconds
4	Headlamp	LO for 10 seconds → HI ON ⇔ OFF 5 times
5	A/C compressor (magnet clutch)	ON ⇔ OFF 5 times
6	Cooling fan*	LO for 5 seconds → HI for 5 seconds

DIAGNOSIS SYSTEM (IPDM E/R)

< SYSTEM DESCRIPTION >

*: Outputs duty ratio of 50% for 5 seconds → duty ratio of 100% for 5 seconds on the cooling fan control module.

Concept of auto active test

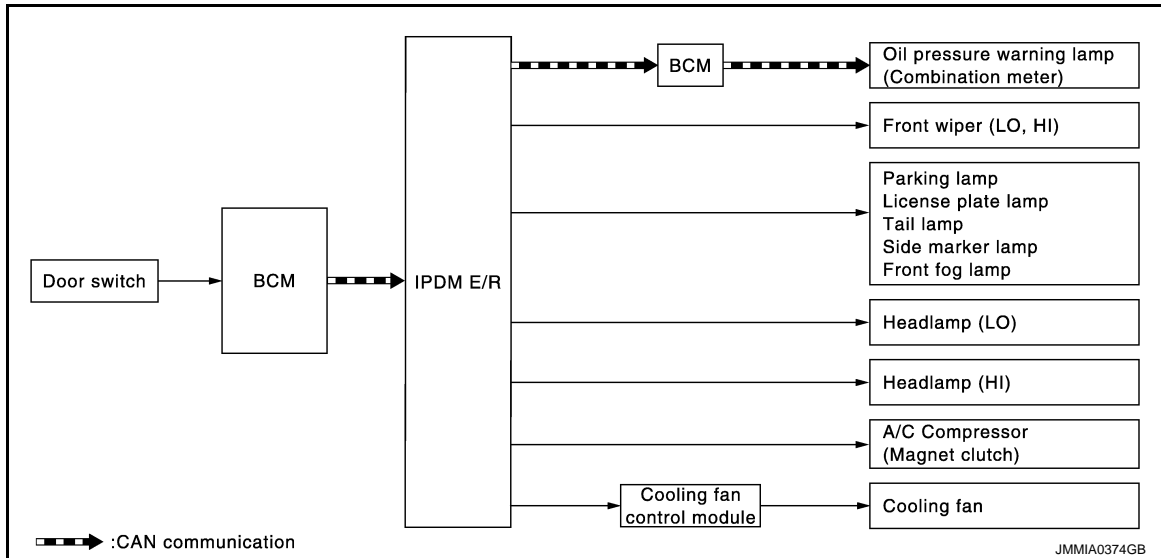

- IPDM E/R starts the auto active test with the door switch signals transmitted by BCM via CAN communication. Therefore, the CAN communication line between IPDM E/R and BCM is considered normal if the auto active test starts successfully.
- The auto active test facilitates troubleshooting if any systems controlled by IPDM E/R cannot be operated.

Diagnosis chart in auto active test mode

Symptom	Inspection contents	Possible cause
Oil pressure warning lamp does not operate	Perform auto active test. Does the oil pressure warning lamp blink?	YES <ul style="list-style-type: none"> • Harness or connector between IPDM E/R and oil pressure switch • Oil pressure switch • IPDM E/R
		NO <ul style="list-style-type: none"> • CAN communication signal between BCM and IPDM E/R • CAN communication signal between BCM and combination meter • Combination meter
Any of the following components do not operate <ul style="list-style-type: none"> • Front wiper motor • Parking lamp • License plate lamp • Tail lamp • Side marker lamp • Front fog lamp • Headlamp (HI, LO) 	Perform auto active test. Does the applicable system operate?	YES BCM signal input circuit
		NO <ul style="list-style-type: none"> • Lamp or motor • Lamp or motor ground circuit • Harness or connector between IPDM E/R and applicable system • IPDM E/R
A/C compressor does not operate	Perform auto active test. Does the magnet clutch operate?	YES <ul style="list-style-type: none"> • ECM signal input circuit • CAN communication signal between ECM and IPDM E/R
		NO <ul style="list-style-type: none"> • Magnet clutch • Harness or connector between IPDM E/R and magnet clutch • IPDM E/R

DIAGNOSIS SYSTEM (IPDM E/R)

< SYSTEM DESCRIPTION >

Symptom	Inspection contents	Possible cause	
Cooling fan does not operate	Perform auto active test. Does the cooling fan operate?	YES	<ul style="list-style-type: none"> ECM signal input circuit CAN communication signal between ECM and IPDM E/R
		NO	<ul style="list-style-type: none"> Harness or connector between IPDM E/R and cooling fan motor Cooling fan control module Cooling fan relay 1 Cooling fan motor IPDM E/R

CONSULT Function (IPDM E/R)

INFOID:000000009728920

APPLICATION ITEM

CONSULT performs the following functions via CAN communication with IPDM E/R.

Diagnosis mode	Description
ECU Identification	Allows confirmation of IPDM E/R part number.
Self Diagnostic Result	Displays the diagnosis results judged by IPDM E/R.
Data Monitor	Displays the real-time input/output data from IPDM E/R input/output data.
Active Test	IPDM E/R can provide a drive signal to electronic components to check their operations.
CAN Diag Support Monitor	The results of transmit/receive diagnosis of CAN communication can be read.

SELF DIAGNOSTIC RESULT

Refer to [PCS-22. "DTC Index"](#).

DATA MONITOR

NOTE:

The following table includes information (items) inapplicable to this vehicle. For information (items) applicable to this vehicle, refer to CONSULT display items.

Monitor Item [Unit]	MAIN SIGNALS	Description
RAD FAN REQ [%]	×	Displays the value of the cooling fan speed request signal received from ECM via CAN communication.
AC COMP REQ [Off/On]	×	Displays the status of the A/C compressor request signal received from ECM via CAN communication.
TAIL&CLR REQ [Off/On]	×	Displays the status of the position light request signal received from BCM via CAN communication.
HL LO REQ [Off/On]	×	Displays the status of the low beam request signal received from BCM via CAN communication.
HL HI REQ [Off/On]	×	Displays the status of the high beam request signal received from BCM via CAN communication.
FR FOG REQ [Off/On]	×	Displays the status of the front fog light request signal received from BCM via CAN communication.
FR WIP REQ [Stop/1LOW/Low/Hi]	×	Displays the status of the front wiper request signal received from BCM via CAN communication.
WIP AUTO STOP [STOP P/ACT P]	×	Displays the status of the front wiper stop position signal judged by IPDM E/R.
WIP PROT [Off/BLOCK]	×	Displays the status of the front wiper fail-safe operation judged by IPDM E/R.
IGN RLY1 -REQ [Off/On]		Displays the status of the ignition switch ON signal received from BCM via CAN communication.
IGN RLY [Off/On]	×	Displays the status of the ignition relay judged by IPDM E/R.

DIAGNOSIS SYSTEM (IPDM E/R)

< SYSTEM DESCRIPTION >

Monitor Item [Unit]	MAIN SIGNALS	Description
PUSH SW [Off/On]		Displays the status of the push-button ignition switch judged by IPDM E/R.
INTER/NP SW [Off/On]		Displays the status of the shift position judged by IPDM E/R.
ST RLY CONT [Off/On]		Displays the status of the starter relay status signal received from BCM via CAN communication.
IHBT RLY -REQ [Off/On]		Displays the status of the starter control relay signal received from BCM via CAN communication.
ST/INH RLY [Off/ ST ON/INH ON/UNK- WN]		Displays the status of the starter relay and starter control relay judged by IPDM E/R.
DETENT SW [Off/On]		Displays the status of the A/T shift selector (detention switch) judged by IPDM E/R.
S/L RLY -REQ [Off/On]		NOTE: The item is indicated, but not monitored.
S/L STATE [LOCK/UNLK/UNKWN]		NOTE: The item is indicated, but not monitored.
DTRL REQ [Off/On]		Displays the status of the daytime running light request signal received from BCM via CAN communication.
OIL P SW [Open/Close]		Displays the status of the oil pressure switch judged by IPDM E/R.
HOOD SW [Off/On]		Displays the status of the hood switch judged by IPDM E/R.
HL WASHER REQ [Off/On]		NOTE: The item is indicated, but not monitored.
THFT HRN REQ [Off/On]		Displays the status of the theft warning horn request signal received from BCM via CAN communication.
HORN CHIRP [Off/On]		Displays the status of the horn reminder signal received from BCM via CAN communication.
HOOD SW 2 [Off/On]		NOTE: The item is indicated, but not monitored.

ACTIVE TEST

Test item	Operation	Description
HORN	On	Operates horn relay for 20 ms.
FRONT WIPER	Off	OFF
	Lo	Operates the front wiper relay.
MOTOR FAN	Hi	Operates the front wiper relay and front wiper HI/LO relay.
	1	OFF
	2	
	3	Operates the cooling fan relay (MID operation).
	4	Operates the cooling fan relay (HI operation).
HEAD LAMP WASHER	On	NOTE: The item is indicated, but cannot be tested.

DIAGNOSIS SYSTEM (IPDM E/R)

< SYSTEM DESCRIPTION >

Test item	Operation	Description
EXTERNAL LAMPS	Off	OFF
	TAIL	Operates the tail lamp relay.
	Lo	Operates the headlamp low relay.
	Hi	Operates the headlamp low relay and ON/OFF the headlamp high relay at 1 second intervals.
	Fog	Operates the front fog lamp relay.

BCM, IPDM E/R

< ECU DIAGNOSIS INFORMATION >

ECU DIAGNOSIS INFORMATION

BCM, IPDM E/R

List of ECU Reference

INFOID:000000009238899

ECU	Reference
BCM	BCS-35, "Reference Value"
	BCS-60, "Fail-safe"
	BCS-61, "DTC Inspection Priority Chart"
	BCS-62, "DTC Index"
IPDM E/R	PCS-15, "Reference Value"
	PCS-21, "Fail-safe"
	PCS-22, "DTC Index"

A
B
C
D
E
F
G
H
I
J
K
M
N
O
P

WW

WIPER AND WASHER SYSTEM

< WIRING DIAGRAM >

WIRING DIAGRAM

WIPER AND WASHER SYSTEM

Wiring Diagram

INFOID:000000009238900

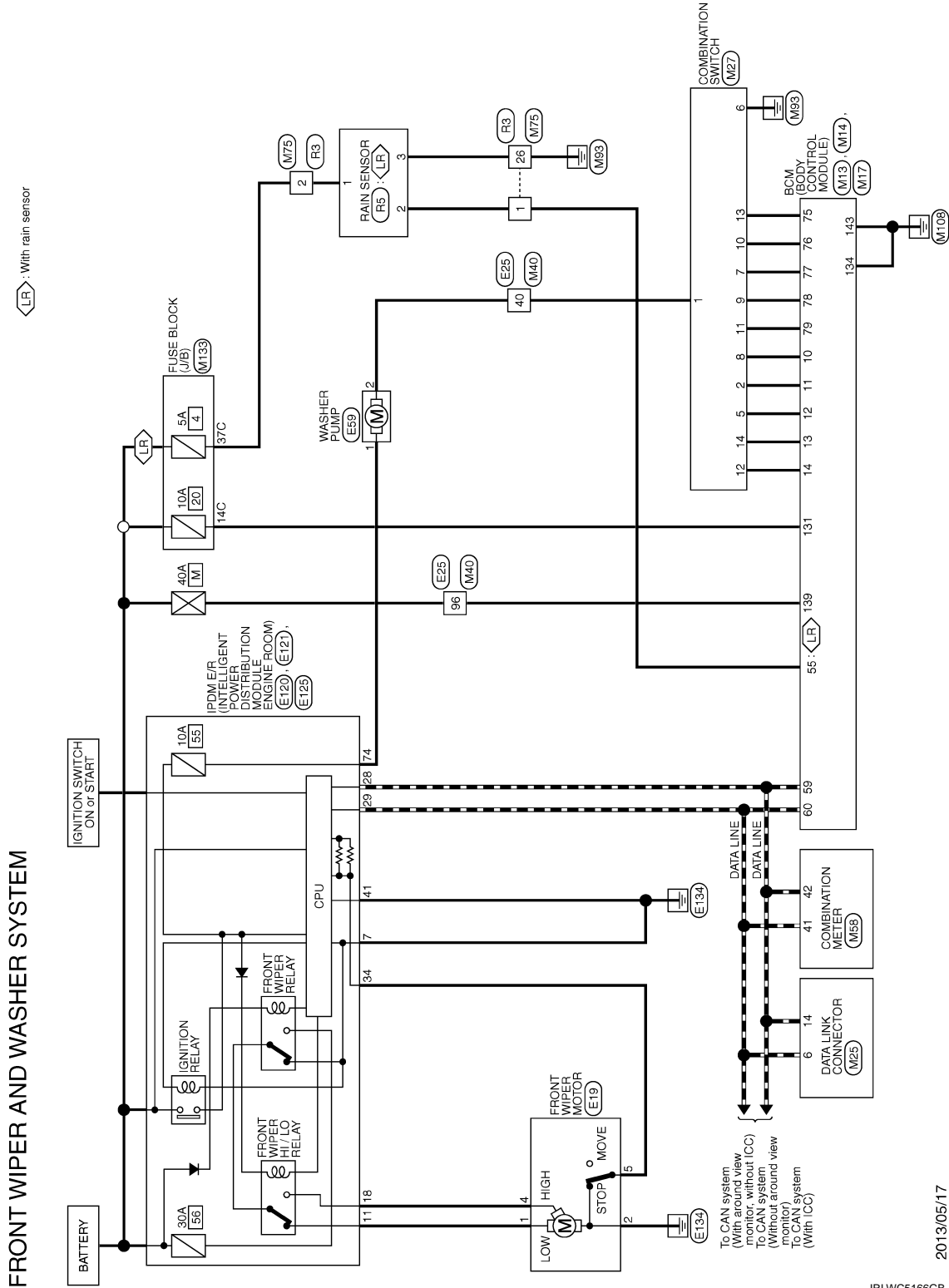

JRLWC5166GB

WIPER AND WASHER SYSTEM

< WIRING DIAGRAM >

FRONT WIPER AND WASHER SYSTEM

Connector No.	E19
Connector Name	FRONT WIPER MOTOR
Connector Type	HS85ECY



Terminal No.	Color Of Wire	Signal Name [Specification]
1	V	-
2	B	-
3	W	-
4	Y	-
5	Y	-

Connector No.	E25
Connector Name	WIRE TO WIRE
Connector Type	TH88PW-CS1R-TM4

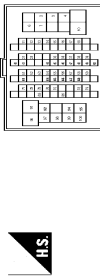

Terminal No.	Color Of Wire	Signal Name [Specification]
1	W	-
2	W	-
3	LG	-
4	BR	-
5	V	-
6	V	-
7	L	-
8	BR	-
9	L	-
10	GR	-
11	L	-
12	GR	-
13	W	-
14	B	-
15	SB	-
16	Y	-
17	BR	-
18	P	-
31	Y	-

32	GR	-
33	GR	-
34	R	-
35	V	-
36	L	-
39	Y	-
40	SB	-
41	LG	-
44	Y	-
45	W	-
46	B	-
47	G	-
48	SHIELD	-
49	R	-
50	BR	-
51	L	-
52	W	-
53	V	-
54	P	-
55	W	-
56	SB	-
57	BG	-
58	B	-
59	W	-
61	R	-
64	Y	-
65	SB	-
66	GR	-
67	LG	-
68	LG	-
72	V	-
73	G	-
74	BR	-
75	V	-
78	P	-
79	SB	-
83	R	-
86	BG	-
91	G	-
92	Y	-
94	GR	-
95	BG	-
97	LG	-
98	L	-
88	P	-
100	SHIELD	-

Connector No.	E59
Connector Name	WASHER PUMP
Connector Type	FEA02FB-LC



Terminal No.	Color Of Wire	Signal Name [Specification]
1	G	-
2	SB	-

Connector No.	E120
Connector Name	POWER IN INTELLIGENT POWER DISTRIBUTION MODULE ENGINE
Connector Type	NS12PW-CS



Terminal No.	Color Of Wire	Signal Name [Specification]
7	B/W	-
9	P	-
10	LG	-
11	V	-
13	Y	-
14	SB	-
15	Y	-
17	GR	-
18	L	-

Connector No.	E121
Connector Name	POWER IN INTELLIGENT POWER DISTRIBUTION MODULE ENGINE
Connector Type	HS12PW-NH

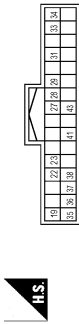

Terminal No.	Color Of Wire	Signal Name [Specification]
19	G	-
21	EG	-
22	EG	-
23	GR	-
27	GR	-
28	P	-
29	L	-
31	G	-
33	SB	-
34	Y	-
35	G	-
36	SB	-
37	GR	-
38	BR	-
41	GR	-
43	V	-

Connector No.	E125
Connector Name	POWER IN INTELLIGENT POWER DISTRIBUTION MODULE ENGINE
Connector Type	NS02PW-CS

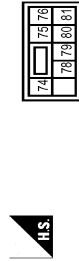

Terminal No.	Color Of Wire	Signal Name [Specification]
74	G	-
75	R	-
76	V	-
78	W	-

JRLWC5167GB

A
B
C
D
E
F
G
H
I
J
K
M
N
O
P

WW

WIPER AND WASHER SYSTEM

< WIRING DIAGRAM >

FRONT WIPER AND WASHER SYSTEM

79	W	IGN SW
80	LG	AV COMB (H)
81	P	CAN-L

Connector No.	M13
Connector Name	BCM (BODY CONTROL MODULE)
Connector Type	TH40FC-NH

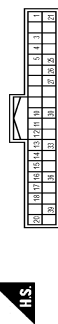

Terminal No.	Wire	Signal Name [Specification]
1	R	PUSH SW
3	Y	SENS PWR SPLY
4	BG	OPTICAL SENSOR
5	LG	-
10	W	COMBI SW OUTPUT 5
11	SB	COMBI SW OUTPUT 4
12	L	COMBI SW OUTPUT 3
13	G	COMBI SW OUTPUT 2
14	P	COMBI SW OUTPUT 1
15	G	ONE TOUCH UNLK SENS (PASS)
16	G	ONE TOUCH UNLK SENS (SEC)
17	P	SECURITY SENS (GND)
18	L	SECURITY IND LAMP CONT
20	R	DETENT SW
21	SB	STOP LAMP SW2
25	R	STOP LAMP SW2
26	R	EXTENDED STORAGE FUSE SW
27	P	STOP LAMP SW
30	W	DR DOOR UNLK SENS
33	V	TR LID OP CANCEL SW
36	G	HAZARD SW
39	BR	P/N POSITION

Connector No.	M14
Connector Name	BCM (BODY CONTROL MODULE)
Connector Type	TH40FB-NH



Terminal No.	Color Of Wire	Signal Name [Specification]
52	R	PUSH BTN IGN SW (LID PWR SPLY)
53	G	ANGLE UNLK COMBI LINE
54	V	RAIN SENSOR
55	R	CAN-L
59	P	CAN-H
60	L	CAN-H
61	G	REAR WINDOW DEF RLY CONT
62	R	STARTER RLY CONT
64	V	I-KEY WARN BUZZER
65	B	OUTS HD LAMP CONT
66	B	BLOWER FAN RLY CONT
67	W/B	IGN RLY (F/B) CONT
68	R	DIMMER
69	GR	A/T SHFT SELECT PWR SPLY
70	R	IGN RLY (F/B) CONT
71	G	DR DOOR REG SW
72	SB	PASS DOOR REG SW
75	BR	COMBI SW INPUT 5
76	BG	COMBI SW INPUT 4
77	V	COMBI SW INPUT 3
78	Y	COMBI SW INPUT 2
79	LG	COMBI SW INPUT 1
80	L	TR LID OPNR SW

Connector No.	M17
Connector Name	BCM (BODY CONTROL MODULE)
Connector Type	FEA08FW-FH46-SA

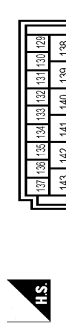

Terminal No.	Color Of Wire	Signal Name [Specification]
132	V	INT ROOM LAMP PWR SPLY
133	P	PASS DOOR UNLK OUTPUT
131	Y	BAT FUSE
132	V	RR_RL DOOR UNLK OUTPUT
133	BR	RR_RL DOOR UNLK OUTPUT
134	B	GND
135	V	FRONT DOOR FL LID UNLK OUTPUT
136	V	INT ROOM LAMP CONT
137	LG	FRONT DOOR FL LID UNLK OUTPUT
138	P	REAR DOORS ACT PWR SPLY
139	W	BAT (F/L)
140	BR	IGN ON
141	R	PWR SPLY (BAT)
142	R	FRONT DOORS FL LID ACT PWR SPLY
143	B	GND

Connector No.	M25
Connector Name	DATA LINK CONNECTOR
Connector Type	BD10FW



Terminal No.	Color Of Wire	Signal Name [Specification]
3	SB	AV COMB (L)
4	B	EARTH
5	B	EARTH
6	L	CAN-H
7	V	KLINE

8	W	IGN SW
11	LG	AV COMB (H)
12	R	CAN-L
13	P	CAN-H
14	P	CAN-L
16	W	POWER

Connector No.	M27
Connector Name	COMBINATION SWITCH
Connector Type	TH10FW-NH

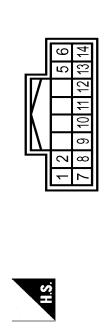

Terminal No.	Color Of Wire	Signal Name [Specification]
1	GR	FR WASH MOTOR
2	SB	OUTPUT 4
5	L	OUTPUT 3
6	B	GND
7	V	INPUT 3
8	W	OUTPUT 5
9	W	INPUT 4
10	EG	INPUT 1
11	LG	INPUT 2
12	P	OUTPUT 1
13	BR	INPUT 5
14	G	OUTPUT 2

JRLWC5168GB

WIPER AND WASHER SYSTEM

< WIRING DIAGRAM >

FRONT WIPER AND WASHER SYSTEM

IC	V	--
----	---	----

Connector No.	R3
Connector Name	WIRE TO WIRE
Connector Type	TH32MM-NH



Terminal No.	Color Of Wire	Signal Name [Specification]
1	R	--
2	GR	--
3	W	--
4	BR	--
5	R	--
6	G	--
7	B	--
10	BR	--
11	SB	--
12	GR	--
14	B	--
17	SHIELD	--
18	R	--
19	L	--
21	LG	--
22	V	--
23	GR	--
25	W	--
26	B	--
27	BR	--
28	BG	--
29	BG	--
31	W	--
32	L	--

Connector No.	R5
Connector Name	RAIN SENSOR
Connector Type	A4B00FE3



Terminal No.	Color Of Wire	Signal Name [Specification]
1	GR	--
2	R	--
3	B	--

JRLWC5170GB

DIAGNOSIS AND REPAIR WORK FLOW

< BASIC INSPECTION >

BASIC INSPECTION

DIAGNOSIS AND REPAIR WORK FLOW

Work Flow

INFOID:000000009728930

OVERALL SEQUENCE

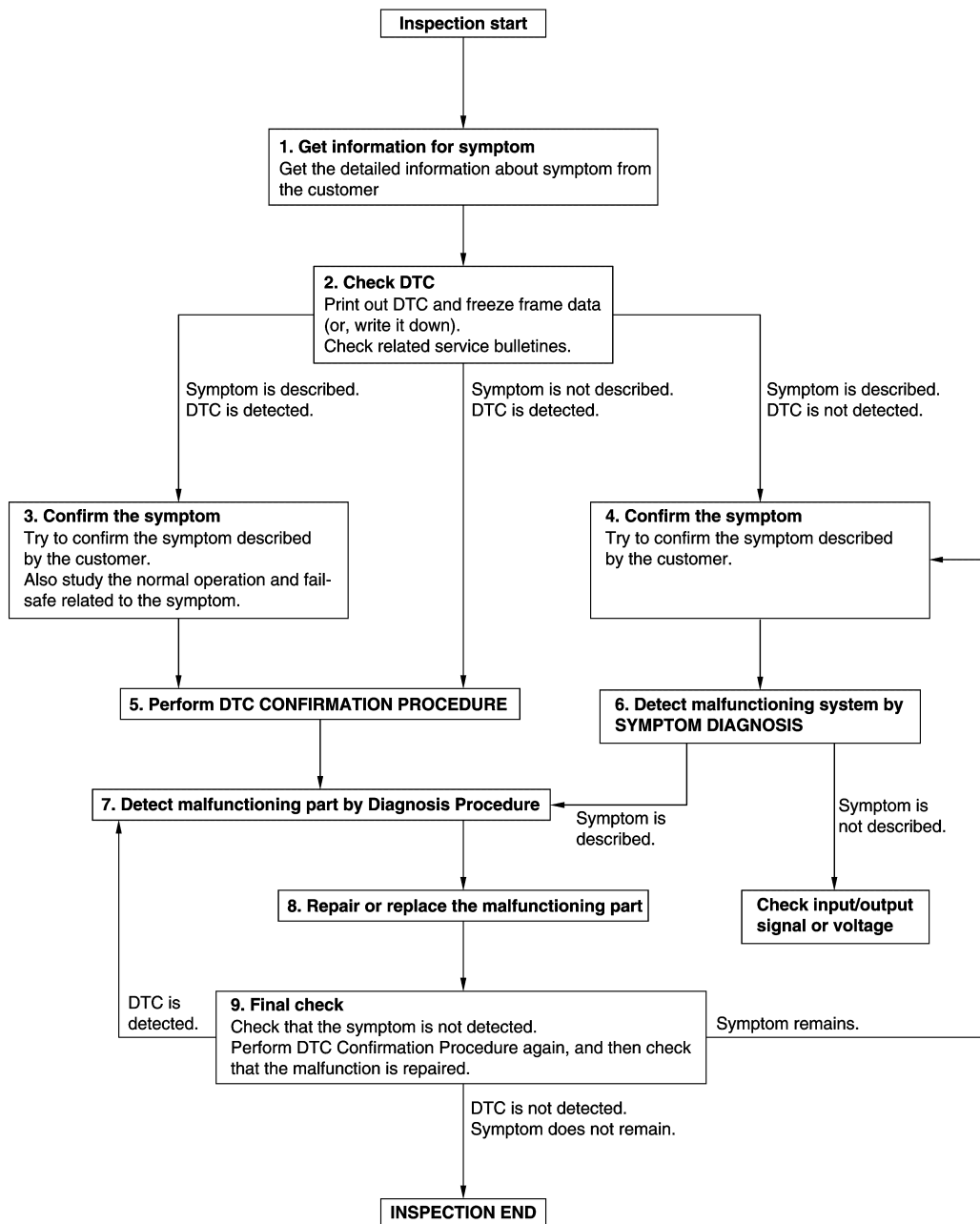

DETAILED FLOW

JMKIA8652GB

DIAGNOSIS AND REPAIR WORK FLOW

< BASIC INSPECTION >

1. GET INFORMATION FOR SYMPTOM

1. Get detailed information from the customer about the symptom (the condition and the environment when the incident/malfunction occurs).
2. Check operation condition of the function that is malfunctioning.

>> GO TO 2.

2. CHECK DTC

1. Check DTC.
2. Perform the following procedure if DTC is detected.
 - Record DTC and freeze frame data (Print them out using CONSULT.)
 - Erase DTC.
 - Study the relationship between the cause detected by DTC and the symptom described by the customer.
3. Check related service bulletins for information.

Are any symptoms described and any DTC detected?

Symptom is described, DTC is detected>>GO TO 3.

Symptom is described, DTC is not detected>>GO TO 4.

Symptom is not described, DTC is detected>>GO TO 5.

3. CONFIRM THE SYMPTOM

Try to confirm the symptom described by the customer.

Also study the normal operation and fail-safe related to the symptom.

Verify relation between the symptom and the condition when the symptom is detected.

>> GO TO 5.

4. CONFIRM THE SYMPTOM

Try to confirm the symptom described by the customer.

Verify relation between the symptom and the condition when the symptom is detected.

>> GO TO 6.

5. PERFORM DTC CONFIRMATION PROCEDURE

Perform DTC CONFIRMATION PROCEDURE for the detected DTC, and then check that DTC is detected again. At this time, always connect CONSULT to the vehicle, and check self diagnostic results in real time. If two or more DTCs are detected, refer to DTC INSPECTION PRIORITY CHART, and determine trouble diagnosis order.

NOTE:

- Freeze frame data is useful if the DTC is not detected.
- Perform Component Function Check if DTC CONFIRMATION PROCEDURE is not included on Service Manual. This simplified check procedure is an effective alternative though DTC cannot be detected during this check.
If the result of Component Function Check is NG, it is the same as the detection of DTC by DTC CONFIRMATION PROCEDURE.

Is DTC detected?

YES >> GO TO 7.

NO >> Check according to [GI-43. "Intermittent Incident"](#).

6. DETECT MALFUNCTIONING SYSTEM BY SYMPTOM DIAGNOSIS

Detect malfunctioning system according to SYMPTOM DIAGNOSIS based on the confirmed symptom in step 4, and determine the trouble diagnosis order based on possible causes and symptom.

Is the symptom described?

YES >> GO TO 7.

NO >> Monitor input data from related sensors or check voltage of related module terminals using CONSULT.

7. DETECT MALFUNCTIONING PART BY DIAGNOSIS PROCEDURE

DIAGNOSIS AND REPAIR WORK FLOW

< BASIC INSPECTION >

Inspect according to Diagnosis Procedure of the system.

Is malfunctioning part detected?

YES >> GO TO 8.

NO >> Check according to [GI-43. "Intermittent Incident"](#).

8. REPAIR OR REPLACE THE MALFUNCTIONING PART

1. Repair or replace the malfunctioning part.
2. Reconnect parts or connectors disconnected during Diagnosis Procedure again after repair and replacement.
3. Check DTC. If DTC is detected, erase it.

>> GO TO 9.

9. FINAL CHECK

When DTC is detected in step 2, perform DTC CONFIRMATION PROCEDURE again, and then check that the malfunction is repaired securely.

When symptom is described by the customer, refer to confirmed symptom in step 3 or 4, and check that the symptom is not detected.

Is DTC detected and does symptom remain?

YES-1 >> DTC is detected: GO TO 7.

YES-2 >> Symptom remains: GO TO 4.

NO >> Before returning the vehicle to the customer, always erase DTC.

A
B
C
D
E
F
G
H
I
J
K
M
N
O
P

WW

FRONT WIPER MOTOR LO CIRCUIT

< DTC/CIRCUIT DIAGNOSIS >

DTC/CIRCUIT DIAGNOSIS

FRONT WIPER MOTOR LO CIRCUIT

Component Function Check

INFOID:000000009728903

1. CHECK FRONT WIPER LO OPERATION

CONSULT ACTIVE TEST

1. Select "FRONT WIPER" of IPDM E/R active test item.
2. With operating the test item, check front wiper operation.

Lo : Front wiper (LO) operation

Off : Stop the front wiper.

Is the inspection result normal?

- YES >> Front wiper motor LO circuit is normal.
NO >> Refer to [WW-38, "Diagnosis Procedure"](#).

Diagnosis Procedure

INFOID:000000009728904

1. CHECK FRONT WIPER MOTOR (LO) OUTPUT VOLTAGE

1. Turn ignition switch OFF.
2. Disconnect front wiper motor connector.
3. Turn ignition switch ON, and wait for 10 seconds.
4. Check voltage between front wiper motor harness connector and ground.

(+)		(-)	Voltage
Front wiper motor			
Connector	Terminal		
E19	1	Ground	9 – 16 V (10 seconds*)

*: According to front wiper protection function, IPDM E/R supplies voltage for 10 seconds (9 – 16 V) and then stops for 20 seconds (0 – 1 V). This operations occurs repeatedly.

Is the inspection result normal?

- YES >> Replace front wiper motor.
NO >> GO TO 2.

2. CHECK FRONT WIPER MOTOR (LO) CIRCUIT

1. Turn ignition switch OFF.
2. Disconnect IPDM E/R connector.
3. Check continuity between IPDM E/R harness connector and front wiper motor harness connector.

IPDM E/R		Front wiper motor		Continuity
Connector	Terminal	Connector	Terminal	
E120	11	E19	1	Existed

4. Check continuity between IPDM E/R harness connector and ground.

IPDM E/R		Ground	Continuity
Connector	Terminal		
E120	11		Not existed

Is the inspection result normal?

- YES >> Replace IPDM E/R. Refer to [PCS-37, "Removal and Installation"](#).
NO >> Repair or replace harness.

FRONT WIPER MOTOR HI CIRCUIT

< DTC/CIRCUIT DIAGNOSIS >

FRONT WIPER MOTOR HI CIRCUIT

Component Function Check

INFOID:000000009728905

1. CHECK FRONT WIPER HI OPERATION

CONSULT ACTIVE TEST

1. Select "FRONT WIPER" of IPDM E/R active test item.
2. With operating the test item, check front wiper operation.

Hi : Front wiper (HI) operation

Off : Stop the front wiper.

Is the inspection result normal?

- YES >> Front wiper motor HI circuit is normal.
NO >> Refer to [WW-39, "Diagnosis Procedure"](#).

Diagnosis Procedure

INFOID:000000009728906

1. CHECK FRONT WIPER MOTOR (HI) OUTPUT VOLTAGE

CONSULT ACTIVE TEST

1. Turn ignition switch OFF.
2. Disconnect front wiper motor connector.
3. Turn ignition switch ON.
4. Select "FRONT WIPER" of IPDM E/R active test item.
5. With operating the test item, check voltage between front wiper motor harness connector and ground.

(+)		(-)	Condition		Voltage
Front wiper motor					
Connector	Terminal				
E19	4	Ground	FRONT WIPER	Hi	9 – 16 V (10 seconds*)

*: According to front wiper protection function, IPDM E/R supplies voltage for 10 seconds (9 – 16 V) and then stops for 20 seconds (0 – 1 V). This operations occurs repeatedly.

Is the inspection result normal?

- YES >> Replace front wiper motor.
NO >> GO TO 2.

2. CHECK FRONT WIPER MOTOR (HI) CIRCUIT

1. Turn ignition switch OFF.
2. Disconnect IPDM E/R connector.
3. Check continuity between IPDM E/R harness connector and front wiper motor harness connector.

IPDM E/R		Front wiper motor		Continuity
Connector	Terminal	Connector	Terminal	
E120	18	E19	4	Existed

4. Check continuity between IPDM E/R harness connector and ground.

IPDM E/R		Ground	Continuity
Connector	Terminal		
E120	18		Not existed

Is the inspection result normal?

- YES >> Replace IPDM E/R. Refer to [PCS-37, "Removal and Installation"](#).
NO >> Repair or replace harness.

FRONT WIPER STOP POSITION SIGNAL CIRCUIT

< DTC/CIRCUIT DIAGNOSIS >

FRONT WIPER STOP POSITION SIGNAL CIRCUIT

Component Function Check

INFOID:000000009728907

1. CHECK FRONT WIPER STOP POSITION SIGNAL

CONSULT DATA MONITOR

1. Select "WIP AUTO STOP" of IPDM E/R data monitor item.
2. Operate the front wiper.
3. With the front wiper operation, check the monitor status.

Monitor item	Condition		Monitor status
WIP AUTO STOP	Front wiper motor	Stop position	STOP P
		Except stop position	ACT P

Is the inspection result normal?

- YES >> Front wiper stop position signal circuit is normal.
NO >> Refer to [WW-40, "Diagnosis Procedure"](#).

Diagnosis Procedure

INFOID:000000009728908

1. CHECK IPDM E/R OUTPUT VOLTAGE

1. Turn ignition switch OFF.
2. Disconnect front wiper motor connector.
3. Turn ignition switch ON.
4. Check voltage between front wiper motor harness connector and ground.

(+)		(-)	Voltage
Front wiper motor			
Connector	Terminal	Ground	9 - 16 V
E19	5		

Is the inspection result normal?

- YES >> Replace front wiper motor.
NO >> GO TO 2.

2. CHECK FRONT WIPER MOTOR (AUTO STOP) CIRCUIT

1. Turn ignition switch OFF.
2. Disconnect IPDM E/R connector.
3. Check continuity between IPDM E/R harness connector and front wiper motor harness connector.

IPDM E/R		Front wiper motor		Continuity
Connector	Terminal	Connector	Terminal	
E121	34	E19	5	Existed

4. Check continuity between IPDM E/R harness connector and ground.

IPDM E/R		Ground	Continuity
Connector	Terminal		
E121	34		Not existed

Is the inspection result normal?

- YES >> Replace IPDM E/R. Refer to [PCS-37, "Removal and Installation"](#).
NO >> Repair or replace harness.

FRONT WIPER MOTOR GROUND CIRCUIT

< DTC/CIRCUIT DIAGNOSIS >

FRONT WIPER MOTOR GROUND CIRCUIT

Diagnosis Procedure

INFOID:000000009728909

1. CHECK FRONT WIPER MOTOR GROUND CIRCUIT

1. Turn ignition switch OFF.
2. Disconnect front wiper motor connector.
3. Check continuity between front wiper motor harness connector and ground.

Front wiper motor		Ground	Continuity
Connector	Terminal		Existed
E19	2		Existed

Is the inspection result normal?

- YES >> INSPECTION END
NO >> Repair or replace harness.

A
B
C
D
E
F
G
H
I
J
K
M
N
O
P

WW

RAIN SENSOR

< DTC/CIRCUIT DIAGNOSIS >

RAIN SENSOR

Component Function Check

INFOID:000000009728910

1.CHECK FRONT WIPER AUTO OPERATION

1. Clean rain sensor detection area of windshield fully.
2. When the front wiper switch is turned to AUTO position, front wiper operates once regardless of a rainy condition.

Is front wiper (AUTO) operation normally?

- YES >> Rain sensor circuit is normal.
NO >> Refer to [WW-42, "Diagnosis Procedure"](#).

Diagnosis Procedure

INFOID:000000009728911

1.CHECK FUSE

1. Turn ignition switch OFF.
2. Check 5 A fuse, [No. 4, located in fuse block (J/B)].

Is the inspection result normal?

- YES >> GO TO 2.
NO >> Replace the blown fuse after repairing the affected circuit if a fuse is blown.

2.CHECK RAIN SENSOR POWER SUPPLY

1. Disconnect rain sensor connector.
2. Check voltage between rain sensor harness connector and ground.

(+)		(-)	Voltage (Approx.)
Rain sensor			
Connector	Terminal	Ground	Battery voltage
R5	1		

Is the inspection result normal?

- YES >> GO TO 3.
NO >> Repair or replace harness.

3.CHECK RAIN SENSOR GROUND CIRCUIT

Check continuity between rain sensor harness connector and ground.

Rain sensor		Ground	Continuity
Connector	Terminal		
R5	3		Existed

Is the inspection result normal?

- YES >> GO TO 4.
NO >> Repair or replace harness.

4.CHECK RAIN SENSOR SIGNAL

1. Connect rain sensor connector.
2. Turn ignition switch ON.
3. Check signal between BCM harness connector and ground using oscilloscope.

RAIN SENSOR

< DTC/CIRCUIT DIAGNOSIS >

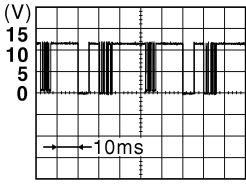
(+)		(-)	Condition	Signal (Reference value)
BCM				
Connector	Terminal			
M14	55	Ground	Ignition switch ON	 <p style="text-align: right;">JPMIA0156GB Approx. 8.7V</p>

Is the inspection result normal?

YES >> Replace rain sensor.

NO >> GO TO 5.

5. CHECK RAIN SENSOR SIGNAL CIRCUIT

1. Turn ignition switch OFF.
2. Disconnect BCM connector and rain sensor connector.
3. Check continuity between BCM harness connector and rain sensor harness connector.

BCM		Rain sensor		Continuity
Connector	Terminal	Connector	Terminal	
M14	55	R5	2	Existed

4. Check continuity between BCM harness connector and ground.

BCM		Ground	Continuity
Connector	Terminal		
M14	55		Not existed

Is the inspection result normal?

YES >> Replace BCM. Refer to [BCS-98, "Removal and Installation"](#).

NO >> Repair or replace harness.

A
B
C
D
E
F
G
H
I
J
K
M
N
O
P

WW

WASHER SWITCH

< DTC/CIRCUIT DIAGNOSIS >

WASHER SWITCH

Component Inspection

INFOID:000000009728912

1. CHECK WASHER SWITCH

1. Turn ignition switch OFF.
2. Disconnect combination switch connector.
3. Check continuity between the combination switch terminals.

Combination switch		Condition	Continuity
Terminal			
1	6	washer switch ON	Existed

Is the inspection result normal?

- YES >> INSPECTION END
NO >> Replace combination switch.

WIPER AND WASHER SYSTEM SYMPTOMS

< SYMPTOM DIAGNOSIS >

SYMPTOM DIAGNOSIS

WIPER AND WASHER SYSTEM SYMPTOMS WITH RAIN SENSOR

WITH RAIN SENSOR : Symptom Table

INFOID:000000009728913

Symptom		Probable malfunction location	Inspection item
Front wiper does not operate	HI only	<ul style="list-style-type: none"> Combination switch Harness between combination switch and BCM BCM 	Combination switch Refer to BCS-96, "Symptom Table" .
		<ul style="list-style-type: none"> IPDM E/R Harness between IPDM E/R and front wiper motor Front wiper motor 	Front wiper motor (HI) circuit Refer to WW-39, "Component Function Check" .
		Front wiper request signal <ul style="list-style-type: none"> BCM IPDM E/R 	IPDM E/R DATA MONITOR "FR WIP REQ"
	LO only	<ul style="list-style-type: none"> Combination switch Harness between combination switch and BCM BCM 	Combination switch Refer to BCS-96, "Symptom Table" .
		<ul style="list-style-type: none"> IPDM E/R Harness between IPDM E/R and front wiper motor Front wiper motor 	Front wiper motor (LO) circuit Refer to WW-38, "Component Function Check" .
		Front wiper request signal <ul style="list-style-type: none"> BCM IPDM E/R 	IPDM E/R DATA MONITOR "FR WIP REQ"
	AUTO only	<ul style="list-style-type: none"> Combination switch Harness between combination switch and BCM BCM 	Combination switch Refer to BCS-96, "Symptom Table" .
		<ul style="list-style-type: none"> Rain sensor Harness between rain sensor and BCM BCM 	Rain sensor Refer to WW-42, "Component Function Check" .
	HI, LO and AUTO	SYMPTOM DIAGNOSIS "FRONT WIPER DOES NOT OPERATE" Refer to WW-50, "Diagnosis Procedure" .	

A
B
C
D
E
F
G
H
I
J
K
M
N
O
P

WW

WIPER AND WASHER SYSTEM SYMPTOMS

< SYMPTOM DIAGNOSIS >

Symptom	Probable malfunction location	Inspection item	
Front wiper does not stop	HI only	<ul style="list-style-type: none"> • Combination switch • BCM 	Combination switch Refer to BCS-96, "Symptom Table" .
		<ul style="list-style-type: none"> Front wiper request signal • BCM • IPDM E/R 	IPDM E/R DATA MONITOR "FR WIP REQ"
		IPDM E/R	—
	LO only	<ul style="list-style-type: none"> • Combination switch • BCM 	Combination switch Refer to BCS-96, "Symptom Table" .
		<ul style="list-style-type: none"> Front wiper request signal • BCM • IPDM E/R 	IPDM E/R DATA MONITOR "FR WIP REQ"
		IPDM E/R	—
	AUTO only	<ul style="list-style-type: none"> • Combination switch • BCM 	Combination switch Refer to BCS-96, "Symptom Table" .
		<ul style="list-style-type: none"> • Rain sensor • Harness between rain sensor and BCM • BCM 	Rain sensor Refer to WW-42, "Component Function Check" .
	Front wiper does not operate normally	Sensitivity adjustment cannot be performed.	<ul style="list-style-type: none"> • Combination switch • Harness between combination switch and BCM • BCM
BCM			—
Auto wiping operation does not operate		Check that the wiper setting is auto wiping operation Refer to WW-21, "WIPER : CONSULT Function (BCM - WIPER)" .	
Service positioning operation does not operate		<ul style="list-style-type: none"> • Combination switch • BCM • IPDM E/R 	Combination switch Refer to BCS-96, "Symptom Table" .
Wiper is not linked to the washer operation.		<ul style="list-style-type: none"> • Combination switch • Harness between combination switch and BCM • BCM 	Combination switch Refer to BCS-96, "Symptom Table" .
		BCM	—
Does not return to stop position. [Repeatedly operates for 10 seconds and then stops for 20 seconds. (Fail-safe)]		<ul style="list-style-type: none"> • IPDM E/R • Harness between IPDM E/R and front wiper motor • Front wiper motor 	Front wiper stop position signal circuit Refer to WW-40, "Component Function Check" .

WITHOUT RAIN SENSOR

WIPER AND WASHER SYSTEM SYMPTOMS

< SYMPTOM DIAGNOSIS >

WITHOUT RAIN SENSOR : Symptom Table

INFOID:000000009728914

Symptom		Probable malfunction location	Inspection item
Front wiper does not operate	HI only	<ul style="list-style-type: none"> • Combination switch • Harness between combination switch and BCM • BCM 	Combination switch Refer to BCS-96, "Symptom Table" .
		<ul style="list-style-type: none"> • IPDM E/R • Harness between IPDM E/R and front wiper motor • Front wiper motor 	Front wiper motor (HI) circuit Refer to WW-39, "Component Function Check" .
		Front wiper request signal • BCM • IPDM E/R	IPDM E/R Data monitor "FR WIP REQ"
	LO and INT	<ul style="list-style-type: none"> • IPDM E/R • Harness between IPDM E/R and front wiper motor • Front wiper motor 	Front wiper motor (LO) circuit Refer to WW-38, "Component Function Check" .
	LO only	<ul style="list-style-type: none"> • Combination switch • Harness between combination switch and BCM • BCM 	Combination switch Refer to BCS-96, "Symptom Table" .
		Front wiper request signal • BCM • IPDM E/R	IPDM E/R Data monitor "FR WIP REQ"
	INT only	<ul style="list-style-type: none"> • Combination switch • Harness between combination switch and BCM • BCM 	Combination switch Refer to BCS-96, "Symptom Table" .
		Front wiper request signal • BCM • IPDM E/R	IPDM E/R Data monitor "FR WIP REQ"
	HI, LO and INT	SYMPTOM DIAGNOSIS "FRONT WIPER DOES NOT OPERATE" Refer to WW-50, "Diagnosis Procedure" .	
	Front wiper does not stop	HI only	<ul style="list-style-type: none"> • Combination switch • BCM
Front wiper request signal • BCM • IPDM E/R			IPDM E/R Data monitor "FR WIP REQ"
IPDM E/R			—
LO only		<ul style="list-style-type: none"> • Combination switch • BCM 	Combination switch Refer to BCS-96, "Symptom Table" .
		Front wiper request signal • BCM • IPDM E/R	IPDM E/R Data monitor "FR WIP REQ"
		IPDM E/R	—
INT only		<ul style="list-style-type: none"> • Combination switch • BCM 	Combination switch refer to BCS-96, "Symptom Table" .
		Front wiper request signal • BCM • IPDM E/R	IPDM E/R Data monitor "FR WIP REQ"

A
B
C
D
E
F
G
H
I
J
K
M
N
O
P

WW

WIPER AND WASHER SYSTEM SYMPTOMS

< SYMPTOM DIAGNOSIS >

Symptom		Probable malfunction location	Inspection item
Front wiper does not operate normally	Intermittent adjustment cannot be performed	<ul style="list-style-type: none"> • Combination switch • Harness between combination switch and BCM • BCM 	Combination switch Refer to BCS-96. "Symptom Table" .
		BCM	—
	Intermittent control linked with vehicle speed cannot be performed	Check the wiper setting is linked with vehicle speed. Refer to WW-21. "WIPER : CONSULT Function (BCM - WIPER)" .	
	Service positioning operation does not operate	<ul style="list-style-type: none"> • Combination switch • BCM • IPDM E/R 	Combination switch Refer to BCS-96. "Symptom Table" .
	Wiper is not linked to the washer operation	<ul style="list-style-type: none"> • Combination switch • Harness between combination switch and BCM • BCM 	Combination switch Refer to BCS-96. "Symptom Table" .
	BCM	—	
	Does not return to stop position [Repeatedly operates for 10 seconds and then stops for 20 seconds. (Fail-safe)]	<ul style="list-style-type: none"> • IPDM E/R • Harness between IPDM E/R and front wiper motor • Front wiper motor 	Front wiper stop position signal circuit Refer to WW-40. "Component Function Check" .

NORMAL OPERATING CONDITION

< SYMPTOM DIAGNOSIS >

NORMAL OPERATING CONDITION

Description

INFOID:000000009238915

FRONT WIPER MOTOR PROTECTION FUNCTION

- IPDM E/R may stop the front wiper to protect the front wiper motor if any obstruction (operation resistance) such as a large amount of snow is detected during the front wiper operation.
- At that time turn OFF the front wiper and remove the foreign object. Then wait for approximately 20 seconds or more and reactivate the front wiper. The wiper will operate normally.

A
B
C
D
E
F
G
H
I
J
K
M
N
O
P

WW

FRONT WIPER DOES NOT OPERATE

< SYMPTOM DIAGNOSIS >

FRONT WIPER DOES NOT OPERATE

Description

INFOID:000000009730155

The front wiper does not operate under any operation conditions.

Diagnosis Procedure

INFOID:000000009730156

1. CHECK WIPER RELAY OPERATION

CONSULT ACTIVE TEST

1. Select "FRONT WIPER" of IPDM E/R active test item.
2. With operating the test item, check front wiper operation.

Lo : Front wiper LO operation

Hi : Front wiper HI operation

Off : Stop the front wiper.

Is front wiper operation normally?

YES >> GO TO 4.

NO >> GO TO 2.

2. CHECK FRONT WIPER MOTOR FUSE

1. Turn ignition switch OFF.
2. Check that the following fuse is not fusing.

Unit	Location	No.	Capacity
Front wiper motor	IPDM E/R	56	30 A

Is the inspection result normal?

YES >> GO TO 3.

NO >> Replace the fuse after repairing the applicable circuit.

3. CHECK FRONT WIPER MOTOR GROUND CIRCUIT

Check front wiper motor ground circuit. Refer to [WW-41, "Diagnosis Procedure"](#).

Is the inspection result normal?

YES >> GO TO 4.

NO >> Repair or replace harness.

4. CHECK FRONT WIPER REQUEST SIGNAL INPUT

CONSULT DATA MONITOR

1. Select "FR WIP REQ" of IPDM E/R data monitor item.
2. Switch the front wiper switch to HI and LO.
3. With operating the front wiper switch, check the status of "FR WIP REQ".

Monitor item	Condition	Monitor status
FR WIP REQ	HI	Hi
	LO	Low
	INT	1Low
	OFF	Stop

Is the inspection result normal?

YES >> Replace IPDM E/R. Refer to [PCS-37, "Removal and Installation"](#).

NO >> GO TO 5.

5. CHECK COMBINATION SWITCH

Perform the inspection of the combination switch. Refer to [BCS-96, "Symptom Table"](#).

Is combination switch normal?

FRONT WIPER DOES NOT OPERATE

< SYMPTOM DIAGNOSIS >

- YES >> Replace BCM. Refer to [BCS-98. "Removal and Installation"](#).
- NO >> Repair or replace the applicable parts.

- A
- B
- C
- D
- E
- F
- G
- H
- I
- J
- K
- WW**
- M
- N
- O
- P

FRONT WIPER

< REMOVAL AND INSTALLATION >

REMOVAL AND INSTALLATION

FRONT WIPER

Exploded View

INFOID:000000009642726

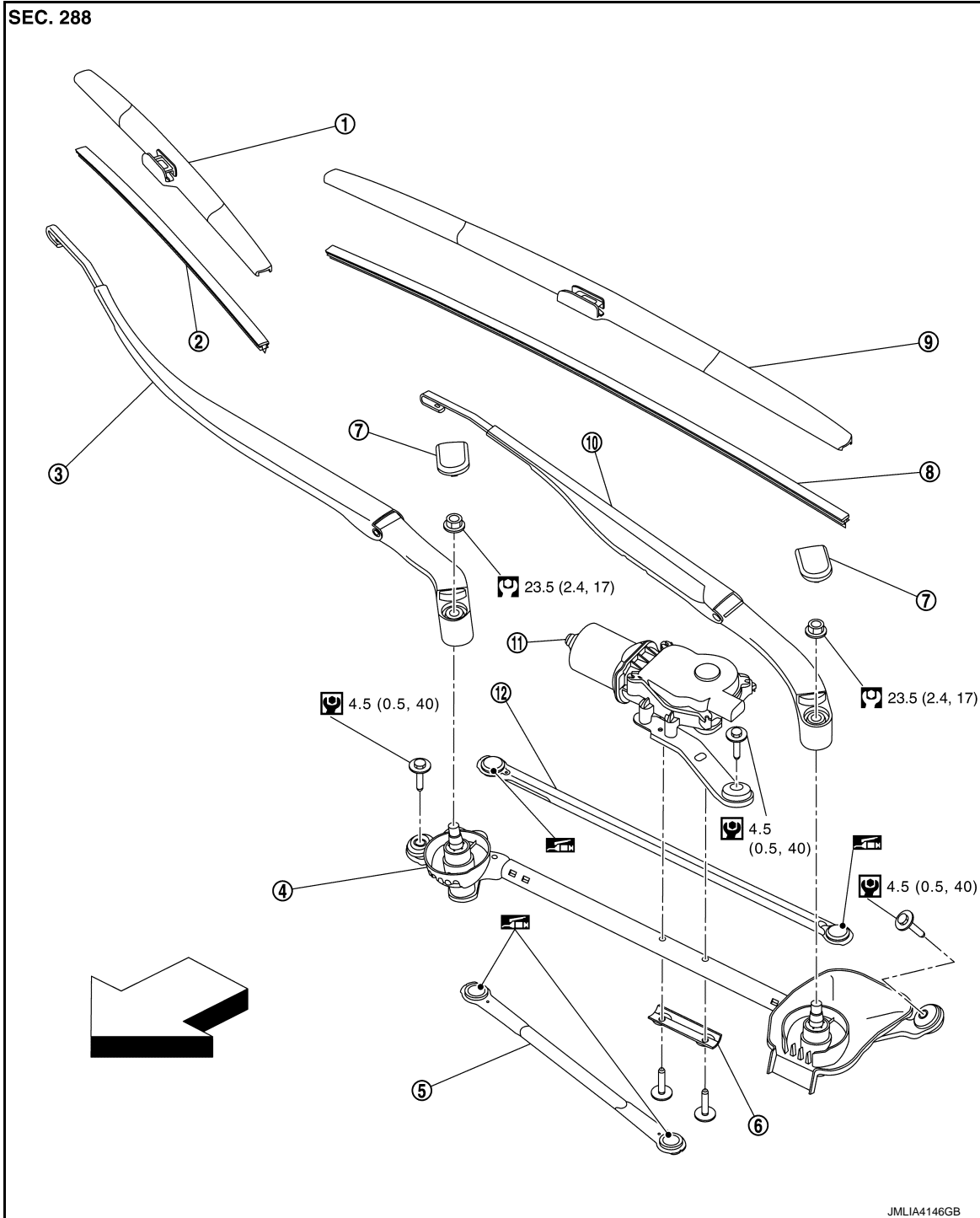

JMLIA4146GB

① Wiper blade RH

② Wiper refill RH

③ Wiper arm RH

④ Wiper linkage*

⑤ Wiper link 1*

⑥ Spacer*

⑦ Wiper arm cap

⑧ Wiper refill LH

⑨ Wiper blade LH

⑩ Wiper arm LH

⑪ Wiper motor*

⑫ Wiper link 2*

FRONT WIPER

< REMOVAL AND INSTALLATION >

 : Vehicle front

 : N·m (kg·m, in·lb)

 : N·m (kg·m, ft·lb)

 : Nissan MP special grease No. 2

:: Part of wiper drive assembly.

WIPER ARM

WIPER ARM : Removal and Installation

INFOID:000000009642727

CAUTION:

Clean the windshield glass and wiper refill so that the windshield glass may not be damaged by dust, etc.

REMOVAL

1. Full open hood assembly.

CAUTION:

Before opening hood assembly, check that wipers are in auto stop position.

2. Remove wiper arm cap using a remover tool (A).

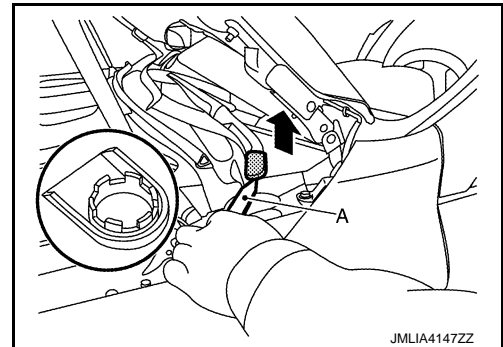

3. Remove wiper arm fixing nut, and then remove wiper arm.

INSTALLATION

Note the following items, and then install in the reverse order of removal.

CAUTION:

- Clean wiper arm installation location as shown in the figure, and then fully insert wiper arm to prevent nut from being loosened by shakiness.

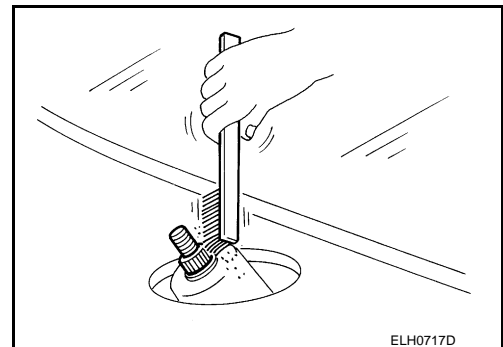

- When installing the wiper arm, install so that it is within the standard. For the standard, refer to [WW-53, "WIPER ARM : Adjustment"](#).
- After installation, operate front wiper, and then check that the wiper blades stop at the specified position. Refer to [WW-53, "WIPER ARM : Adjustment"](#).

WIPER ARM : Adjustment

INFOID:000000009642728

CAUTION:

Clean the windshield glass and wiper refill so that the windshield glass may not be damaged by dust, etc.

WIPER BLADE POSITION ADJUSTMENT

A
B
C
D
E
F
G
H
I
J
K
WW
M
N
O
P

FRONT WIPER

< REMOVAL AND INSTALLATION >

Clearance between the end of cowl top cover / front fender cover and the top of wiper blade center.

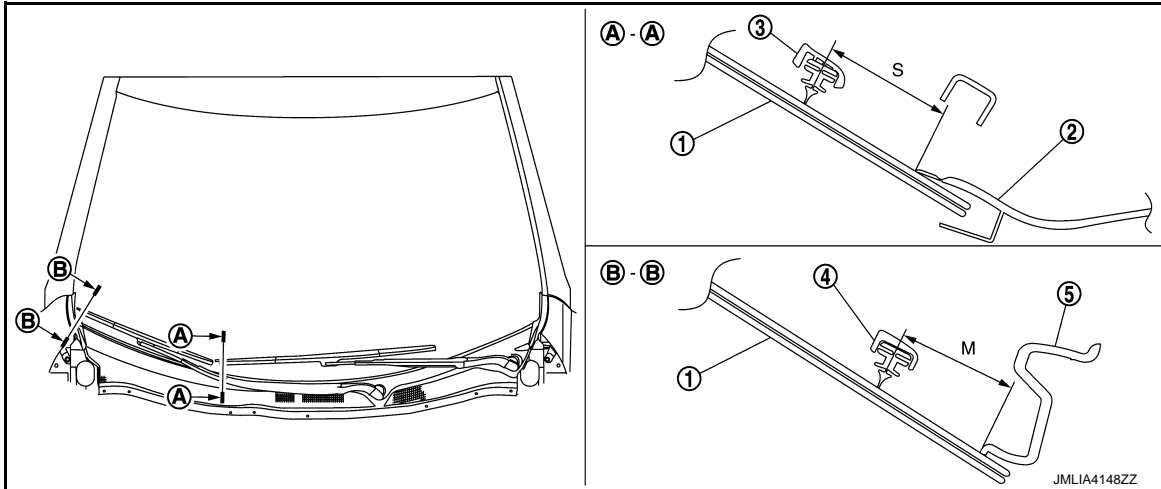

- | | | |
|-----------------------------|----------------------|------------------|
| ① Windshield glass assembly | ② Cowl top cover | ③ Wiper blade LH |
| ④ Wiper blade RH | ⑤ Front fender cover | |

Standard clearance

S : 39.0 ± 7.5 mm (1.54 ± 0.30 in)

M : 39.0 ± 7.5 mm (1.54 ± 0.30 in)

WIPER BLADE

WIPER BLADE : Removal and Installation

INFOID:000000009642729

CAUTION:

Clean the windshield glass and wiper refill so that the windshield glass may not be damaged by dust, etc.

REMOVAL

1. Move the wiper arm by service position operation to lock back possibility position. Refer to [WW-8, "FRONT WIPER AND WASHER SYSTEM \(WITH RAIN SENSOR\) : System Description"](#).
2. Lift up wiper arm, and then lock back wiper arm.
3. Slide the wiper blade while pushing up lever (A), and then remove wiper blade.

CAUTION:

After the wiper blade is removed, wrap the wiper arm tip with a shop cloth and fold it down so that the wiper arm does not fall against and damage the windshield glass.

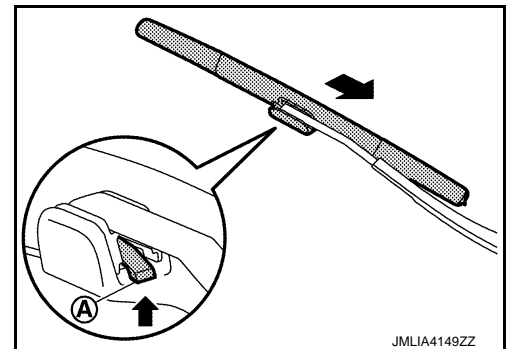

INSTALLATION

Install in the reverse order of removal.

WIPER REFILL

WIPER REFILL : Removal and Installation

INFOID:000000009761015

REMOVAL

1. Remove wiper blade. Refer to [WW-54, "WIPER BLADE : Removal and Installation"](#).

FRONT WIPER

< REMOVAL AND INSTALLATION >

2. Pull out wiper refill using a long-nose pliers (A), and then remove wiper refill.

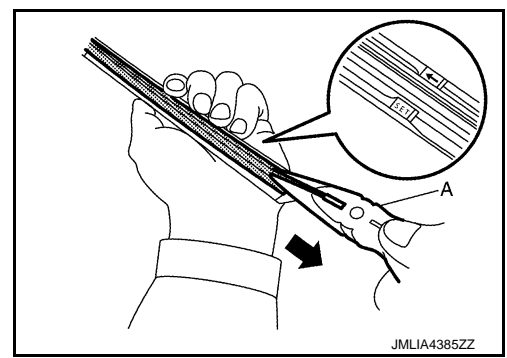

INSTALLATION

1. Check the wiper refill insertion direction by arrow mark on wiper blade.

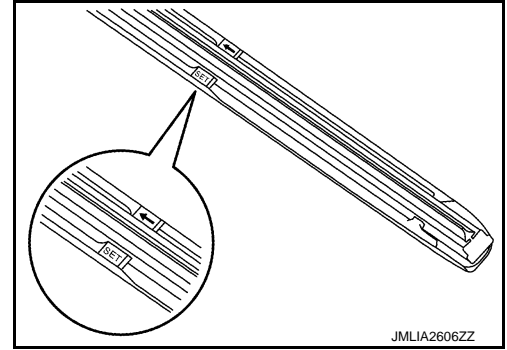

2. Pass through pawl of wiper blade in the groove of wiper refill.

NOTE:

Remove holder ①* at last procedure.

*: Attached to service parts.

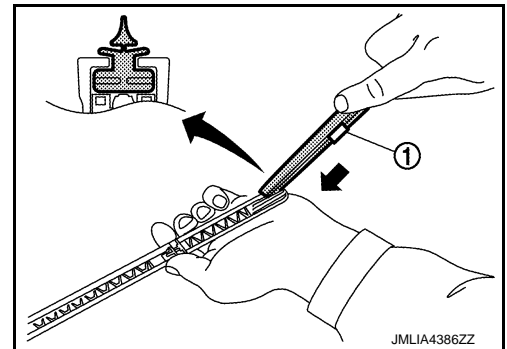

3. Engage wiper refill stopper hole, and wiper blade pawl with imprinted "SET" mark ("←" mark).
4. Check the following items after installing.
 - Wiper refill thoroughly fits in the pawl on wiper blade.
 - Wiper refill is not deformed (waving / tucking).

NOTICE:

When the vertebra is detached

- Insert the vertebra ① into the wiper blade to the same bending direction.
- If a vertebra has a notch, fit it to a protrusion inside the wiper refill.

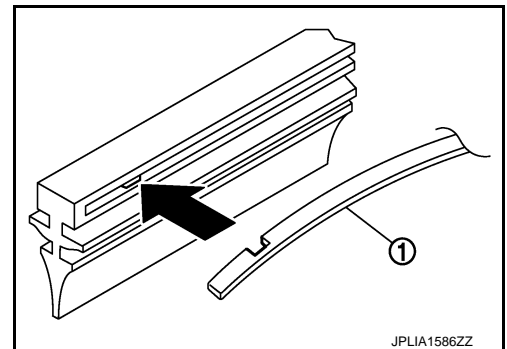

WIPER DRIVE ASSEMBLY

A
B
C
D
E
F
G
H
I
J
K
WW
M
N
O
P

FRONT WIPER

< REMOVAL AND INSTALLATION >

WIPER DRIVE ASSEMBLY : Removal and Installation

INFOID:000000009642730

REMOVAL

1. Remove cowl top cover. Refer to [EXT-26. "Removal and Installation"](#).
2. Disconnect wiper motor harness connector (A), disengage wiper motor harness clip, remove wiper drive assembly fixing bolts (B), and then remove wiper drive assembly.

 : Clip

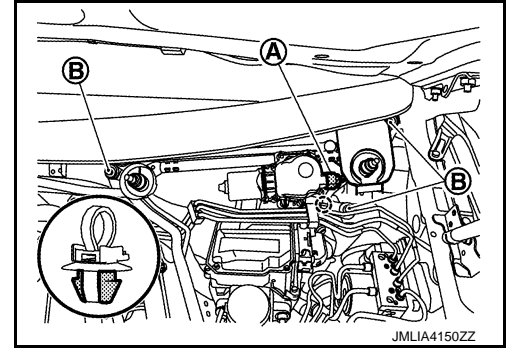

INSTALLATION

Note the following item, and then install in the reverse order of removal.

CAUTION:

When installing, temporarily tighten all fixing bolts, and then tighten bolts to specified torque.

WIPER DRIVE ASSEMBLY : Disassembly and Assembly

INFOID:000000009642731

DISASSEMBLY

1. Remove wiper link 1 and 2 from wiper linkage.
CAUTION:
Never bend the link or damage the plastic part of the ball joint when removing the wiper link.
2. Remove wiper motor fixing bolts, and then remove wiper motor and spacer.

ASSEMBLY

Note the following items, and assemble in the reverse order of disassembly.

CAUTION:

- When the wiper motor is replaced, before installing the wiper arm, operate the wipers, set the wiper motor to the auto stop position, and then install wiper arms.
- Be careful for the grease condition at the wiper link joint (retainer). Apply Multi-purpose grease or an equivalent if necessary.

FRONT WASHER

< REMOVAL AND INSTALLATION >

FRONT WASHER

Exploded View

INFOID:000000009642732

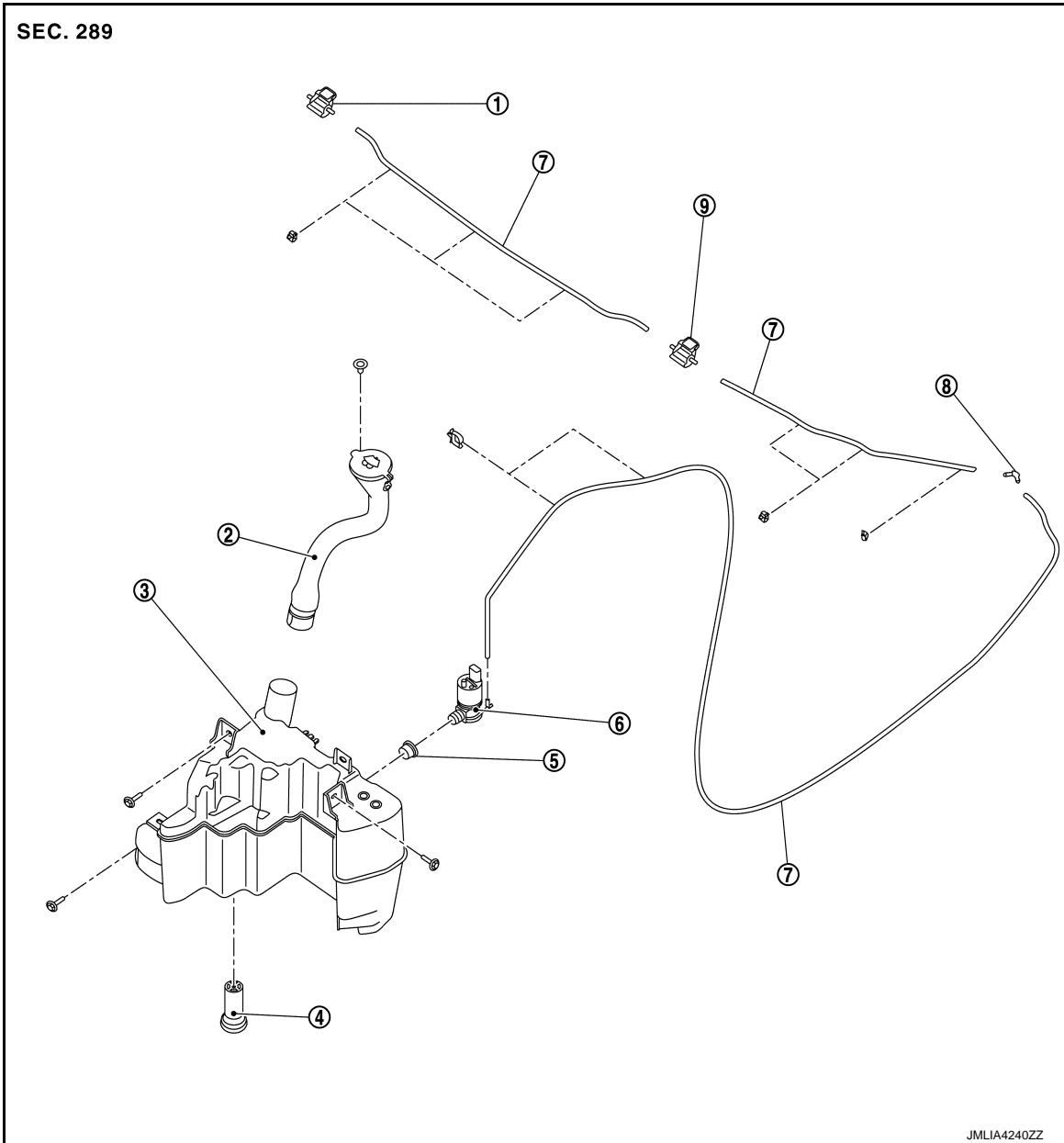

- ① Washer nozzle RH
- ④ Washer level switch
- ⑦ Washer tube

- ② Washer tank inlet
- ⑤ Packing
- ⑧ L-joint

- ③ Washer tank
- ⑥ Washer pump
- ⑨ Washer nozzle LH

A
B
C
D
E
F
G
H
I
J
K
WW
M
N
O
P

FRONT WASHER

< REMOVAL AND INSTALLATION >

Hydraulic Layout

INFOID:000000009642733

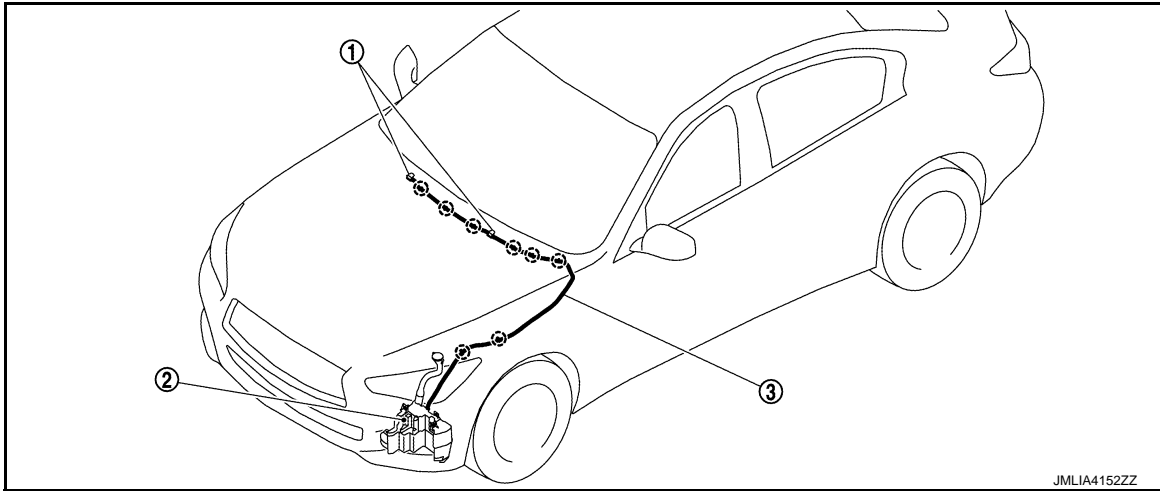

① Washer nozzle

② Washer tank

③ Washer tube

○ : Fixing point

WASHER NOZZLE & TUBE

WASHER NOZZLE & TUBE : Removal and Installation

INFOID:000000009642734

REMOVAL

CAUTION:

When the washer tube is removed, washer fluid may come out so prepare a container to receive the fluid and never allow fluid to be sprinkled.

1. Remove front fender protector front LH. Refer to [EXT-29, "FENDER PROTECTOR : Removal and Installation"](#).
2. Pull out washer tube from washer pump.

⇐ : Vehicle front

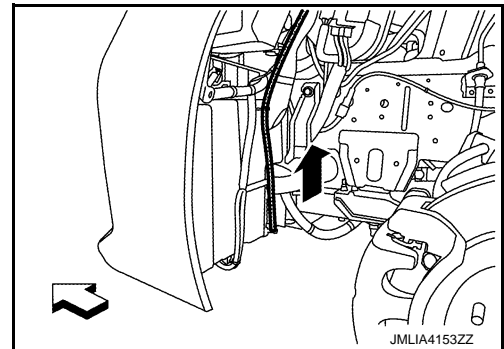

3. Remove washer tube from portion (A) of washer tank, and then pull out washer tube from clips (B).

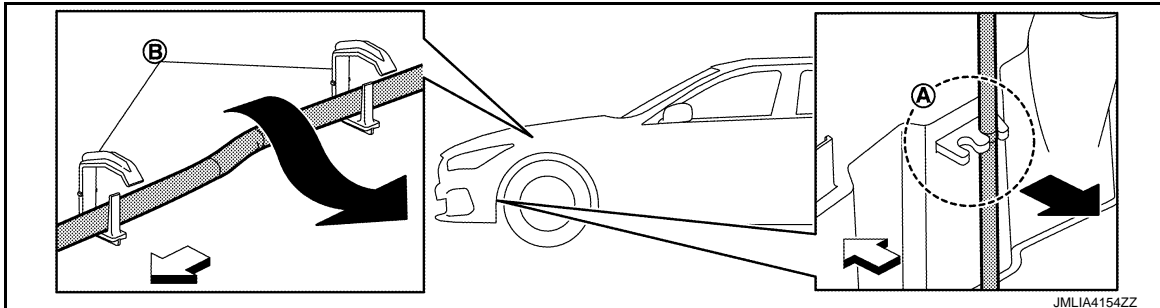

⇐ : Vehicle front

FRONT WASHER

< REMOVAL AND INSTALLATION >

- Remove washer nozzles ③ and disengage clips (A), (B).

CAUTION:

Disengage washer nozzle fixing pawls according to the numerical order 1 → 2 as shown in the figure to prevent damage to the parts.

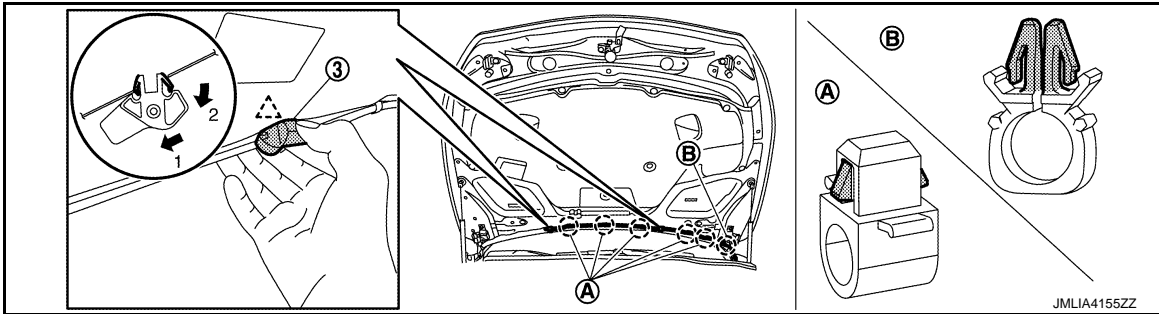

- : Clip
- △ : Pawl

- Pull out washer tube from fender gap, and then remove washer nozzle, washer tube as a set.

CAUTION:

Note how the pipe is installed for reference during installation.

- Separate the washer nozzle, washer tube and L-joint.

INSTALLATION

Note the following item, and then install in the reverse order of removal.

CAUTION:

Adjust the washer nozzle spray position. Refer to [WW-59, "WASHER NOZZLE & TUBE : Inspection and Adjustment"](#).

WASHER NOZZLE & TUBE : Inspection and Adjustment

INFOID:000000009642735

CHECK VALVE INSPECTION

Check that air can pass through by blowing forward direction [toward the nozzle], and check that air cannot pass through by sucking reverse direction [toward washer tank].

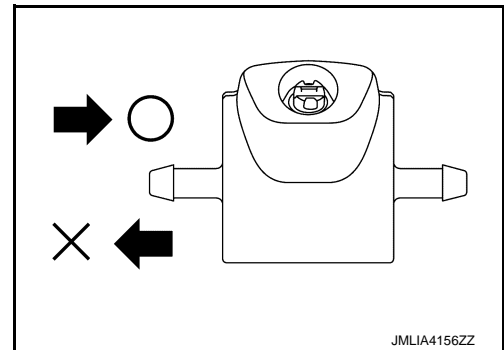

WASHER NOZZLE SPRAY POSITION ADJUSTMENT

Adjust spray positions to match the positions shown in the figure.

NOTE:

The spray position in the LH side is similar to the one in the RH side.

- ① : Black printed frame line
- ▨ : Spray area

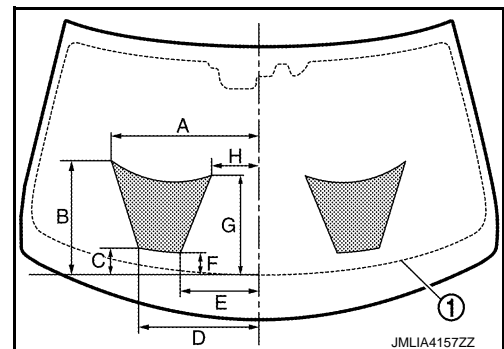

FRONT WASHER

< REMOVAL AND INSTALLATION >

Unit: mm (in)

A	B	C	D	E	F	G	H
437 (17.2)	338 (13.3)	80 (3.1)	835 (14.1)	234 (9.6)	65 (2.6)	295 (11.6)	138 (5.4)

CAUTION:

- When adjusting, always use a washer nozzle adjuster (A).
- Never use needle or small pin.

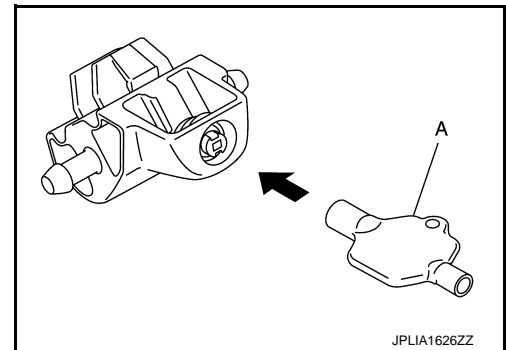

WASHER TANK

WASHER TANK : Removal and Installation

INFOID:000000009642736

REMOVAL

CAUTION:

When the washer tank inlet and washer tube is removed, washer fluid may come out so prepare a container to receive the fluid and never allow fluid to be sprinkled.

1. Remove front fender protector front LH. Refer to [EXT-29, "FENDER PROTECTOR : Removal and Installation"](#).
2. Remove hood side seal assembly. Refer to [DLK-188, "HOOD SEAL : Removal and Installation"](#).
3. Remove front bumper fascia assembly. Refer to [EXT-14, "Removal and Installation"](#).
4. Remove washer tank inlet.
 - a. Remove washer tank inlet fixing clip (A).

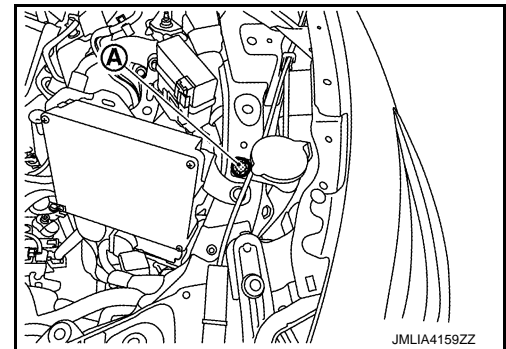

- b. Remove washer tank inlet.

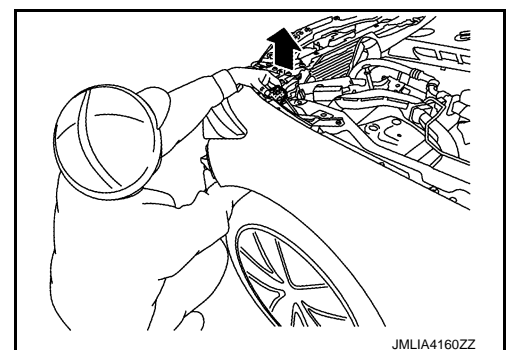

FRONT WASHER

< REMOVAL AND INSTALLATION >

5. Pull out washer tube from washer pump.

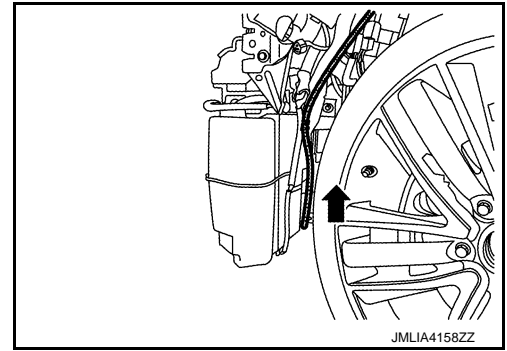

6. Remove washer tank.
 - a. Disengage harness connectors and harness clip.

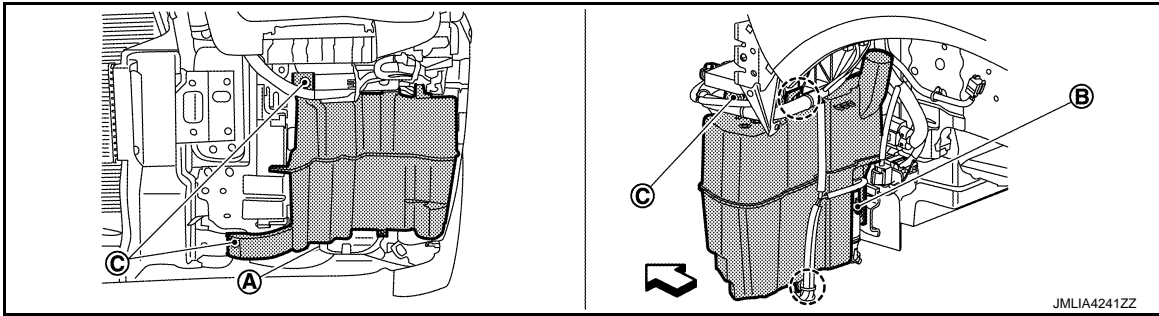

- (A) Washer level switch harness connector (B) Washer pump harness connector (C) Washer tank fixing bolt
 ○ : Clip
 ⇐ : Vehicle front

- b. Remove washer tank fixing bolts , and then remove washer tank.

INSTALLATION

Note the following item, and then install in the reverse order of removal.

CAUTION:

Add washer liquid up to the top of the washer tank inlet after installing. Check that there is no leakage.

WASHER PUMP

WASHER PUMP : Removal and Installation

INFOID:000000009642737

REMOVAL

CAUTION:

When the washer tube and washer pump is removed, washer fluid may come out so prepare a container to receive the fluid and never allow fluid to be sprinkled.

1. Remove front fender protector front LH. Refer to [EXT-29. "FENDER PROTECTOR : Removal and Installation"](#).
2. Pull out washer tube from washer pump.

⇐ : Vehicle front

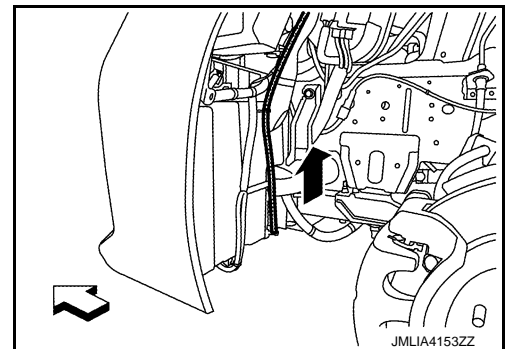

FRONT WASHER

< REMOVAL AND INSTALLATION >

3. Disconnect washer pump harness connector (A), pull washer pump, and then remove washer pump.

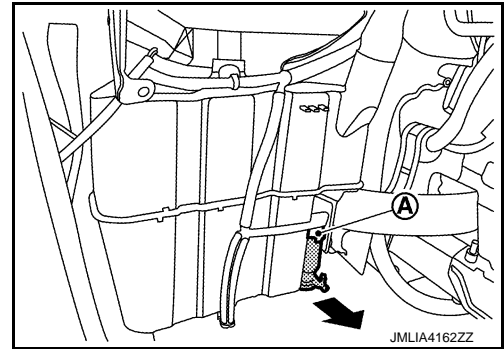

4. Remove packing.

INSTALLATION

Note the following items, and then install in the reverse order of removal.

CAUTION:

- Check that packing is inserted fully. (This may be the cause of washer fluid leakage and washer pump looseness.)
- Add washer liquid up to the top of the washer tank inlet after installing. Check that there is no leakage.

WASHER LEVEL SWITCH

WASHER LEVEL SWITCH : Removal and Installation

INFOID:000000009642738

REMOVAL

CAUTION:

When the washer tube and washer pump is removed, washer fluid may come out so prepare a container to receive the fluid and never allow fluid to be sprinkled.

1. Remove front fender protector front LH. Refer to [EXT-29, "FENDER PROTECTOR : Removal and Installation"](#).
2. Disengage washer level switch harness connector, and then remove washer level switch using a remover tool (A).

⇐ : Vehicle front

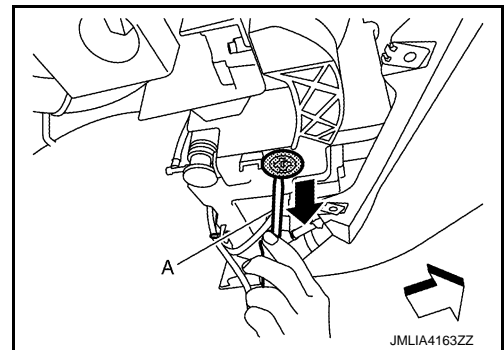

INSTALLATION

Note the following items, and then install in the reverse order of removal.

CAUTION:

- Check that packing is inserted fully. (This may be the cause of washer fluid leakage and washer pump looseness.)
- Add washer liquid up to the top of the washer tank inlet after installing. Check that there is no leakage.

RAIN SENSOR

< REMOVAL AND INSTALLATION >

RAIN SENSOR

Exploded View

INFOID:000000009642745

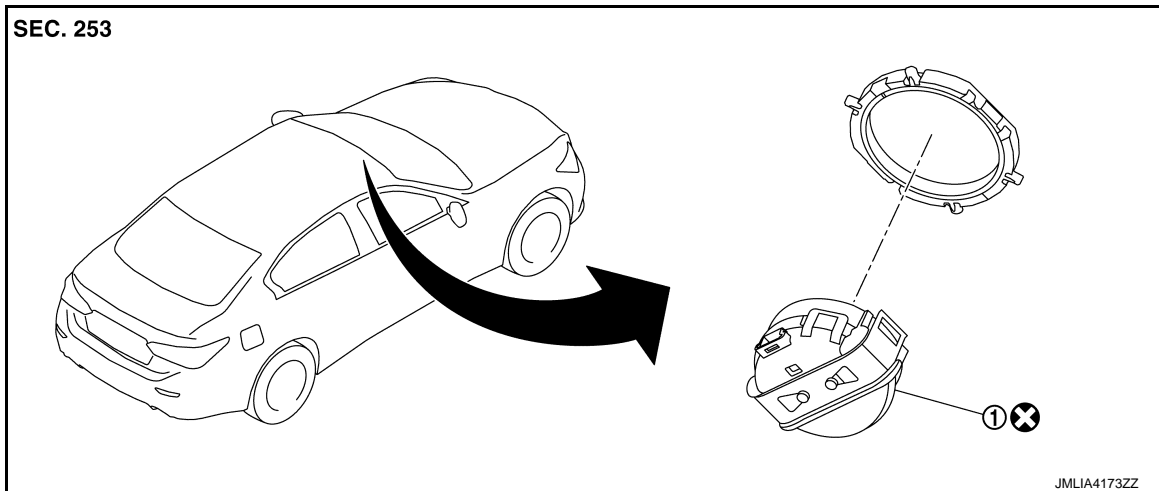

① Rain sensor

⊗ : Always replace after every disassembly.

Removal and Installation

INFOID:000000009642746

REMOVAL

1. Remove inside mirror cover. Refer to [INT-42, "Removal and Installation"](#).
2. Disconnect rain sensor harness connector.
3. Disengage rain sensor fixing lock spring portion (A), and then Peel off rain sensor.

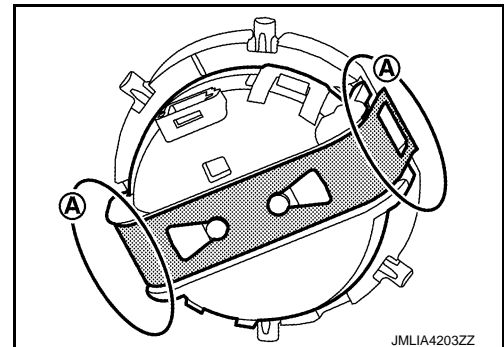

INSTALLATION

Note the following items, and then install in the reverse order of removal.

CAUTION:

- Replace rain sensor with a new part after removal. Never reuse rain sensor.
- Clean the sensor installation portion of the windshield.
- When the sensor is removed, wipe off the silicon pad remaining on the windshield surface.

RAIN SENSOR

< REMOVAL AND INSTALLATION >

- Remove the sensor protective cover just before installation. Never touch the silicon pad (A) after removal of sensor protective cover.

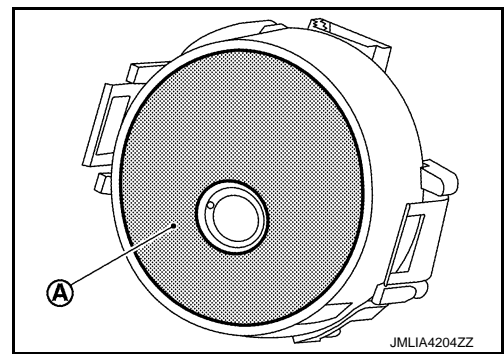

- Install the rain sensor so that the connector faces vehicle upward.
- When installing, never allow silicon pad to touch the sensor bracket and other parts.
- Compress the lock spring portion (A) vertically to the glass surface and fully engage both ends of lock spring.

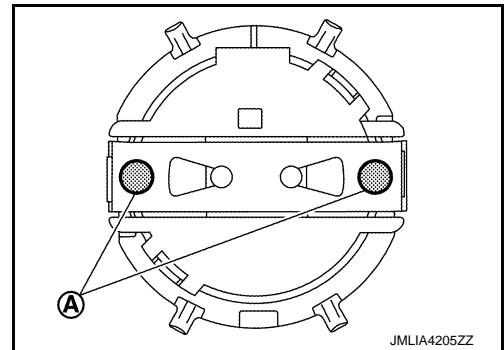

- Never use a sensor that is dropped.
- Perform check after replacement. Refer to [WW-64. "Inspection"](#).

Inspection

INFOID:000000009642747

CAUTION:

Clean the windshield glass and wiper refill so that the windshield glass may not be damaged by dust, etc.

1. Push the ignition switch to the ON position, and set the combination switch to AUTO.
2. Spray water mist toward the sensor.
3. Check that wiper operates.
 - If the wiper does not operate, check the connection of the connector. Refer to [WW-42. "Component Function Check"](#).
 - If there is no malfunction in the connection, replace the sensor.

WIPER AND WASHER SWITCH

< REMOVAL AND INSTALLATION >

WIPER AND WASHER SWITCH

Removal and Installation

INFOID:000000009642748

Wiper and washer switch is integrated in the combination switch. Refer to [BCS-99. "Removal and Installation"](#).

A
B
C
D
E
F
G
H
I
J
K
M
N
O
P

WW