

A
B
C
D
E

SECTION **PB**

PARKING BRAKE SYSTEM

CONTENTS

| | |
|---|---|
| <p>PRECAUTION 2</p> <p>PRECAUTIONS 2 Precautions for Removing Battery Terminal2</p> <p>PREPARATION 3</p> <p>PREPARATION 3 Commercial Service Tools3 Lubricant or/and Sealant3</p> <p>SYSTEM DESCRIPTION 4</p> <p>SYSTEM 4</p> <p>INFORMATION DISPLAY (COMBINATION METER)4 INFORMATION DISPLAY (COMBINATION METER) : Parking Brake Release Warning4</p> <p>WARNING/INDICATOR/CHIME LIST4 WARNING/INDICATOR/CHIME LIST : Warning Lamp/Indicator Lamp4 WARNING/INDICATOR/CHIME LIST : Warning Chime5 WARNING/INDICATOR/CHIME LIST : Warning/Indicator (On Information Display)5</p> | <p>PERIODIC MAINTENANCE 6</p> <p>PARKING BRAKE SYSTEM 6 Inspection and Adjustment 6</p> <p>PARKING BRAKE SHOE 8 Adjustment 8</p> <p>REMOVAL AND INSTALLATION 9</p> <p>PARKING BRAKE CONTROL 9 Exploded View 9 Removal and Installation 9 Adjustment11</p> <p>PARKING BRAKE SHOE12 Exploded View12 Removal and Installation12 Inspection and Adjustment14</p> <p>SERVICE DATA AND SPECIFICATIONS (SDS)16</p> <p>SERVICE DATA AND SPECIFICATIONS (SDS)16 Parking Drum Brake16 Parking Brake Control16</p> |
|---|---|

PB
G
H
I
J
K
L
M
N
O
P

PRECAUTIONS

< PRECAUTION >

PRECAUTION

PRECAUTIONS

Precautions for Removing Battery Terminal

INFOID:0000000011459861

- When removing the 12V battery terminal, turn OFF the ignition switch and wait at least 30 seconds.

NOTE:

ECU may be active for several tens of seconds after the ignition switch is turned OFF. If the battery terminal is removed before ECU stops, then a DTC detection error or ECU data corruption may occur.

- For vehicles with the 2-batteries, be sure to connect the main battery and the sub battery before turning ON the ignition switch.

NOTE:

If the ignition switch is turned ON with any one of the terminals of main battery and sub battery disconnected, then DTC may be detected.

- After installing the 12V battery, always check "Self Diagnosis Result" of all ECUs and erase DTC.

NOTE:

The removal of 12V battery may cause a DTC detection error.

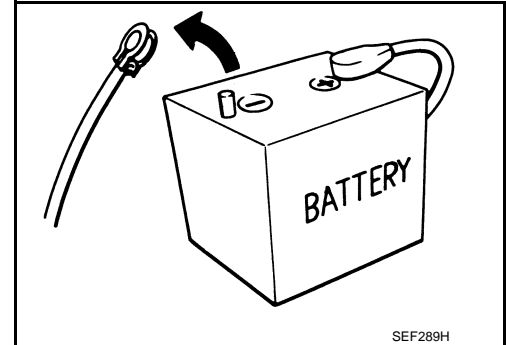

PREPARATION

< PREPARATION >

PREPARATION

PREPARATION

Commercial Service Tools

INFOID:000000011285673

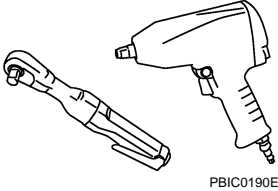
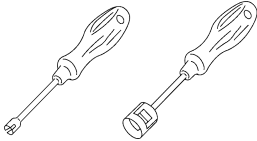
| Tool name | Description |
|--|---|
| Power tool  | Removing bolts and nuts |
| Shoe hold spring tool  | Removing and installing retainer for parking brake shoe |

Lubricant or/and Sealant

INFOID:000000011285674

| Name | Description | Note |
|---|--|------|
| Multi-purpose grease | Parking brake cable | — |
| PBC (Poly Butyl Cuprysil) grease or silicone-based grease | <ul style="list-style-type: none"> • Parking brake shoe • Adjuster • Back plate | — |

SYSTEM

< SYSTEM DESCRIPTION >

SYSTEM DESCRIPTION

SYSTEM

INFORMATION DISPLAY (COMBINATION METER)

INFORMATION DISPLAY (COMBINATION METER) : Parking Brake Release Warning

INFOID:000000011285675

DESIGN/PURPOSE

The parking brake release warning notifies the driver that the parking brake is left applied.

| Symbol | Message |
|--------|-----------------------|
| — | Release parking brake |

SYNCHRONIZATION WITH MASTER WARNING LAMP

Applicable

For master warning lamp, refer to [MWI-34. "WARNING LAMPS/INDICATOR LAMPS : Master Warning Lamp"](#).

SYNCHRONIZATION WITH WARNING CHIME

Applicable

For warning chime, refer to [WCS-15. "WARNING CHIME : Parking Brake Release Warning Chime"](#).

SYSTEM DIAGRAM

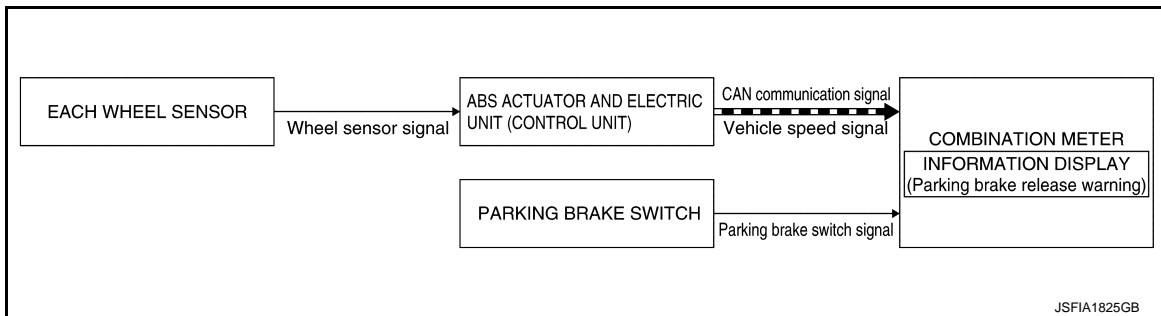

SIGNAL PATH

- The combination meter receives a vehicle speed signal from the ABS actuator and electric unit (control unit) via CAN communication.
- The combination meter receives a parking brake signal from the parking brake switch.
- The combination meter judges that the parking brake is left applied according to the above signals, and displays the parking brake release warning on the information display.

WARNING CONDITION

When all of the conditions listed below are satisfied:

- Ignition switch is ON.
- Vehicle speed is 7 km/h (4.3 MPH) or more.
- Parking brake switch is ON. (Parking brake: applied.)

WARNING CANCEL CONDITION

When any of the conditions listed below is satisfied:

- Ignition switch is in a position other than ON.
- Vehicle speed is 3 km/h (1.9 MPH) or less.
- Parking brake switch is OFF. (Parking brake: Released.)

WARNING/INDICATOR/CHIME LIST

WARNING/INDICATOR/CHIME LIST : Warning Lamp/Indicator Lamp

INFOID:000000011285676

FOR U.S.A.

SYSTEM

< SYSTEM DESCRIPTION >

| Name | Design | Layout/Function |
|--------------------|--------------|---|
| Brake warning lamp | BRAKE | For layout: Refer to MWI-8, "METER SYSTEM : Design" . |
| | | For function: Refer to MWI-21, "WARNING LAMPS/INDICATOR LAMPS : Brake Warning Lamp" . |

FOR CANADA

| Name | Design | Layout/Function |
|--------------------|---|---|
| Brake warning lamp |  | For layout: Refer to MWI-8, "METER SYSTEM : Design" . |
| | | For function: Refer to MWI-21, "WARNING LAMPS/INDICATOR LAMPS : Brake Warning Lamp" . |

WARNING/INDICATOR/CHIME LIST : Warning Chime

INFOID:000000011285677

| Name | Function |
|-------------------------------------|--|
| Parking brake release warning chime | Refer to WCS-15, "WARNING CHIME : Parking Brake Release Warning Chime" . |

WARNING/INDICATOR/CHIME LIST : Warning/Indicator (On Information Display)

INFOID:000000011285678

| Name | Function |
|-------------------------------|--|
| Parking brake release warning | Refer to PB-4, "INFORMATION DISPLAY (COMBINATION METER) : Parking Brake Release Warning" . |

PARKING BRAKE SYSTEM

< PERIODIC MAINTENANCE >

PERIODIC MAINTENANCE

PARKING BRAKE SYSTEM

Inspection and Adjustment

INFOID:000000011285679

INSPECTION

1. Operate the parking brake pedal with a force of 196 N (20 kg, 44 lb). Check that the pedal stroke is within the specified number of notches. (Check it by listening to clicks of ratchet.)

Number of notches : Refer to [PB-16, "Parking Brake Control"](#).

2. When brake warning lamp turns ON, check that the pedal stroke is within the specified number of notches. (Check it by listening to clicks of ratchet.)

Number of notches : Refer to [PB-16, "Parking Brake Control"](#).

Inspect Components

Check the following items and replace if necessary.

- Check each component for installation condition such as looseness.
- Check the parking brake pedal assembly for bend, damage and cracks.
- Check the cables and equalizer for wear, damage and cracks.
- Check the parking brake switch. Refer to [BRC-158, "Component Inspection"](#).

ADJUSTMENT

1. Remove the rear tires with power tool.
2. Fix the disc rotor using wheel nuts.
3. Release the parking brake pedal ② by turning the adjusting nut ① and loosening the cable.

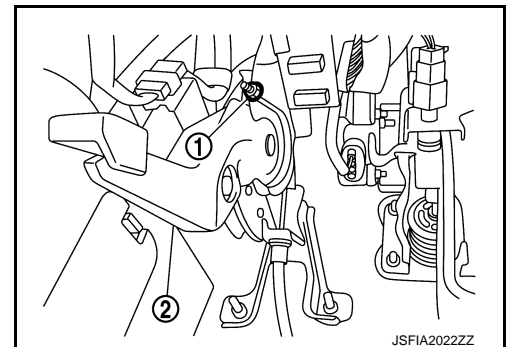

4. Remove the adjusting hole plug from the disc rotor. Turn the adjuster ① in the direction ④ as shown in the figure using a suitable tool until the disc rotor is locked.
5. Turn back the adjuster 5 or 6 notches from the locked position.
6. Rotate the disc rotor to check that there is no drag. Install the plug. If any drag is found, follow the procedure described below.
 - a. Adjust parking brake stroke again.
 - b. Check rear disc brake.
 - Brake caliper 1 piston type: Refer to [BR-72, "BRAKE CALIPER ASSEMBLY \(1 PISTON TYPE\) : Inspection"](#).
 - Brake caliper 2 piston type: Refer to [BR-76, "BRAKE CALIPER ASSEMBLY \(2 PISTON TYPE\) : Inspection"](#).
7. Adjust the cable with the following procedure.
 - a. Temporarily adjust the cable so that the parking brake pedal operating force immediately before the full stroke reaches 490 N (50 kg, 110 lb) or more.
 - b. Operate the parking brake pedal with a force of 490 N (50 kg, 110 lb) for 10 strokes or more.
 - c. Adjust the parking brake pedal stroke by turning the adjusting nut.

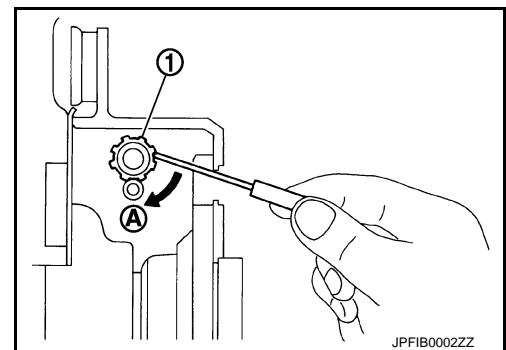

CAUTION:

PARKING BRAKE SYSTEM

< PERIODIC MAINTENANCE >

Never reuse the adjusting nut if the nut is removed.

- d. Operate the parking brake pedal with a force of 196 N (20 kg, 44 lb). Check that the pedal stroke is within the specified number of notches. (Check it by listening to clicks of ratchet.)

Number of notches : Refer to [PB-16, "Parking Brake Control"](#).

- e. Rotate the disc rotor to check that there is no drag. Install the plug. If any drag is found, follow the procedure described below.
- i. Adjust parking brake stroke again.
- ii. Check rear disc brake.
- Brake caliper 1 piston type: Refer to [BR-72, "BRAKE CALIPER ASSEMBLY \(1 PISTON TYPE\) : Inspection"](#).
 - Brake caliper 2 piston type: Refer to [BR-76, "BRAKE CALIPER ASSEMBLY \(2 PISTON TYPE\) : Inspection"](#).

A
B
C
D
E
G
H
I
J
K
L
M
N
O
P

PB

PARKING BRAKE SHOE

< PERIODIC MAINTENANCE >

PARKING BRAKE SHOE

Adjustment

INFOID:000000011285680

1. Adjust parking brake pedal stroke. Refer to [PB-6, "Inspection and Adjustment"](#).
2. Perform parking brake break-in (drag on) operation by driving vehicle under the following conditions:
 - Drive forward
 - Vehicle speed: Approx. 40 km/h (25 MPH) set (constant and forward)
 - Parking brake operating force: 255 N (26.0 kg, 57.3 lb) set contact
 - Time: Approx. 15 sec.

CAUTION:

- **To prevent lining from getting too hot, allow a cool off period of approx. 5 minutes after every break-in operation.**
 - **Never perform excessive break-in operations, because doing so may cause uneven or early wear of the lining.**
3. After the break-in procedure, check parking brake pedal stroke of parking brake.

CAUTION:

If it is out of the specification, adjust again. Refer to [PB-6, "Inspection and Adjustment"](#).

PARKING BRAKE CONTROL

< REMOVAL AND INSTALLATION >

REMOVAL AND INSTALLATION

PARKING BRAKE CONTROL

Exploded View

INFOID:000000011285681

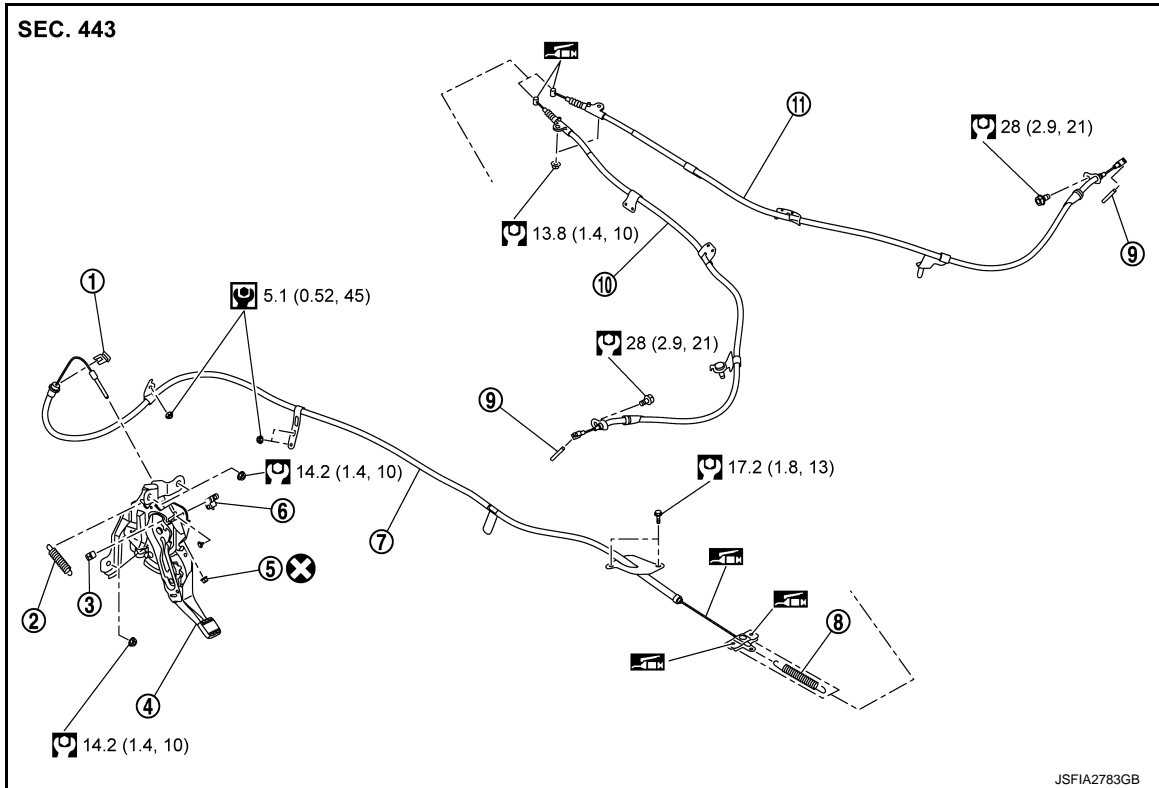

- | | | |
|--------------------------------|---------------------------|------------------------|
| ① Lock plate | ② Return spring | ③ Stopper rubber |
| ④ Parking brake pedal assembly | ⑤ Adjusting nut | ⑥ Parking brake switch |
| ⑦ Front cable | ⑧ Spring | ⑨ Pin |
| ⑩ Rear cable (left side) | ⑪ Rear cable (right side) | |

: Apply multi-purpose grease.

: N·m (kg-m, ft-lb)

: N·m (kg-m, in-lb)

: Always replace after every disassembly.

Removal and Installation

INFOID:000000011285682

REMOVAL

1. Remove rear tires with power tool.
2. Remove instrument lower panel. Refer to [IP-13, "Removal and Installation"](#).
3. Remove dash side finisher LH. Refer to [INT-28, "DASH SIDE FINISHER : Removal and Installation"](#).
4. Remove CAN gateway. Refer to [LAN-172, "Removal and Installation"](#).
5. Disconnect parking brake switch harness connector.

PARKING BRAKE CONTROL

< REMOVAL AND INSTALLATION >

6. Remove adjusting nut ① and loosen front cable ②.
7. Remove parking brake pedal assembly.

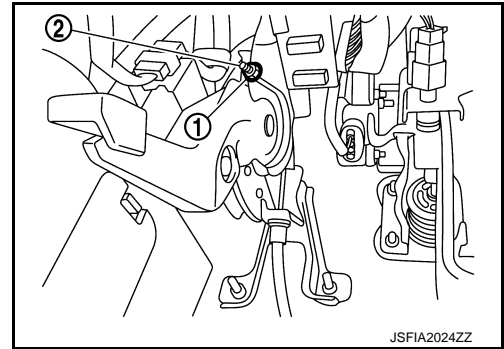

8. Remove the lock plate ① from parking brake pedal assembly ②.
9. Separate front cable from parking brake pedal assembly.
10. Remove center console. Refer to [IP-24, "Removal and Installation"](#).
11. Remove rear floor duct 2. Refer to [VTL-13, "REAR FLOOR DUCT 2 : Removal and Installation"](#).
12. Remove floor carpet assembly. Refer to [INT-37, "Removal and Installation"](#).
13. Remove diagnosis sensor unit. Refer to [SR-37, "Removal and Installation"](#).

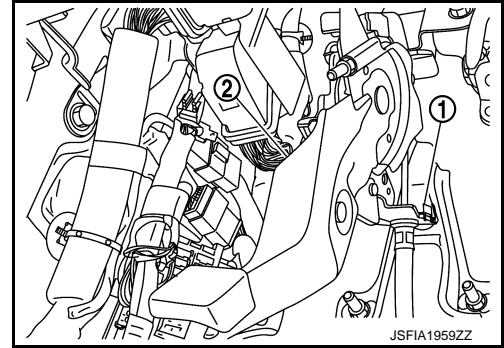

14. Remove front cable mounting bolts and nuts.
15. Remove the center muffler. Refer to [EX-6, "Removal and Installation"](#).
16. Remove heat insulator ①.

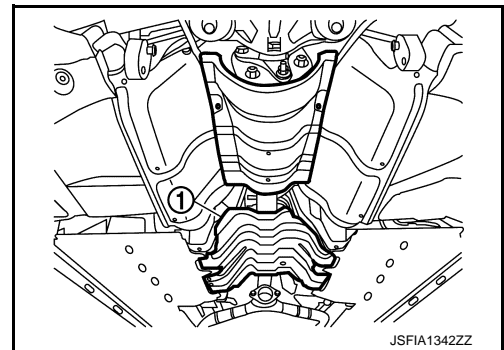

17. Remove rear cable mounting nuts.

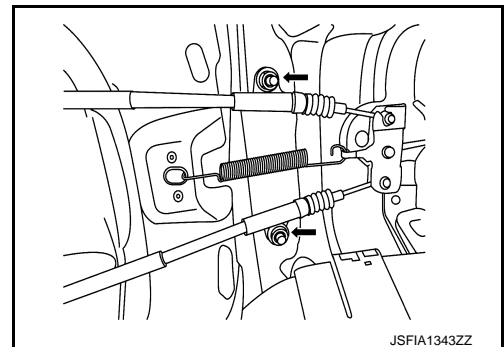

PARKING BRAKE CONTROL

< REMOVAL AND INSTALLATION >

18. Pull rear cable ① in a vehicle front side, and separate front cable ② from notch part ③ of equalizer ④.

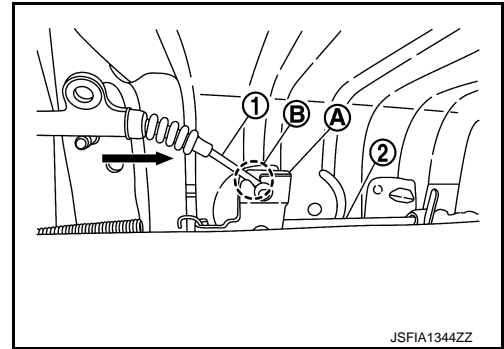

19. Remove spring ①.
20. Pull out the front cable to vehicle inside.
21. Remove disc rotor. Refer to [RAX-8. "Removal and Installation"](#).
22. Remove rear cable from toggle lever. Refer to [PB-12. "Removal and Installation"](#).
23. Remove rear cable mounting bolts and nuts, pull out rear cable from vehicle.

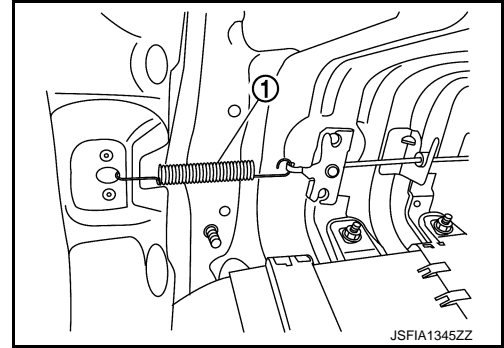

INSTALLATION

Note the following, Install the reverse order of the removal.

- Never reuse the adjusting nut.
- Perform adjustment after installation. Refer to [PB-11. "Adjustment"](#).

Adjustment

INFOID:000000011285683

ADJUSTMENT AFTER INSTALLATION

Adjust the parking brake pedal stroke. Refer to [PB-6. "Inspection and Adjustment"](#).

A
B
C
D
E
PB
G
H
I
J
K
L
M
N
O
P

PARKING BRAKE SHOE

< REMOVAL AND INSTALLATION >

PARKING BRAKE SHOE

Exploded View

INFOID:000000011285684

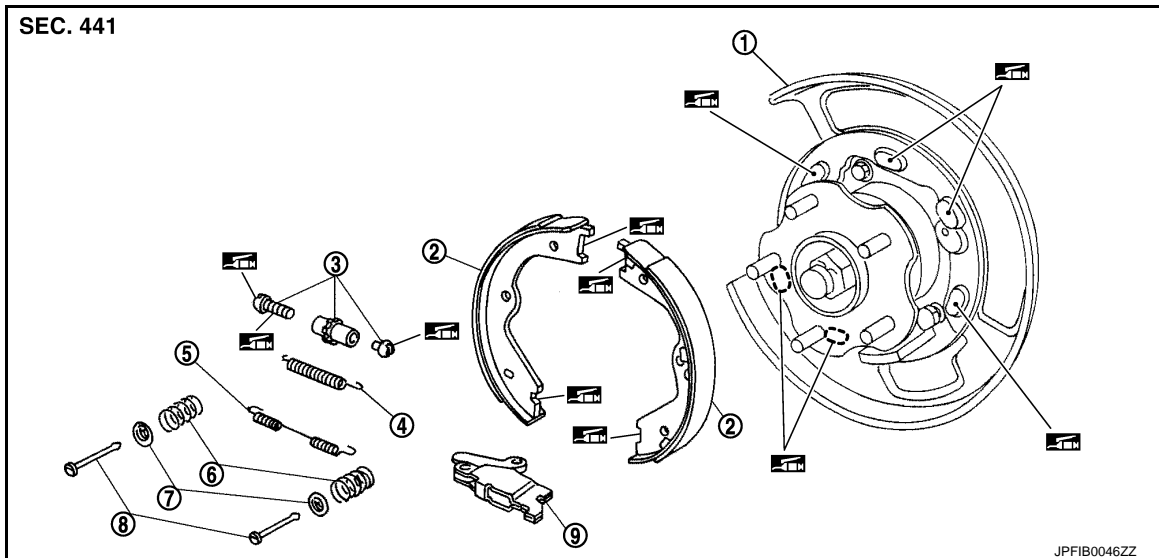

- | | | |
|-------------------|----------------------|----------------------|
| ① Back plate | ② Parking brake shoe | ③ Adjuster |
| ④ Adjuster spring | ⑤ Return spring | ⑥ Anti-rattle spring |
| ⑦ Retainer | ⑧ Anti-rattle pin | ⑨ Toggle lever |

 Apply PBC (Poly Butyl Cuprysil) grease or silicone-based grease.

Removal and Installation

INFOID:000000011285685

REMOVAL

WARNING:

Since dust covering the parking brake shoes and back plates has an affect on human body, the dust must be removed with a dust collector. Never splatter the dust with an air blow gun.

1. Remove rear tires with power tool.
2. Remove disc rotor. Refer to [RAX-8, "Removal and Installation"](#).
3. While pushing and rotating the anti-rattle pin ①, remove anti-rattle pins, retainers, anti-rattle springs.

CAUTION:

Parking brake completely in the release position.

CAUTION:

Never drop the removed parts.

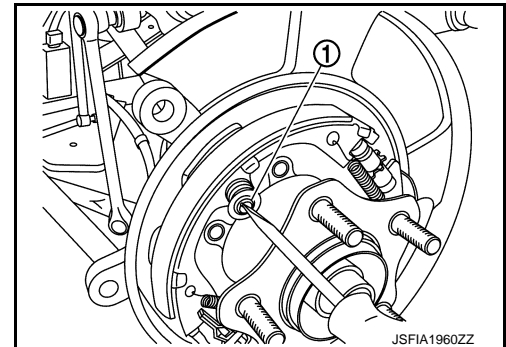

PARKING BRAKE SHOE

< REMOVAL AND INSTALLATION >

4. Remove adjuster spring ①.

CAUTION:

Never drop the removed parts.

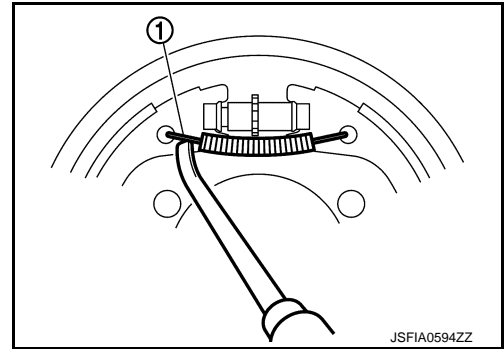

5. Remove return spring ①.

CAUTION:

Never drop the removed parts.

6. Remove parking brake shoes, adjuster, and toggle lever.

CAUTION:

- The parking brake shoes for the front wheels are made of different materials from those for the rear wheels. Never misidentify them when removing.
- Never drop the removed parts.

7. For the removal of back plate, refer to [RAX-8, "Removal and Installation"](#).

8. Perform inspection after removal. Refer to [PB-14, "Inspection and Adjustment"](#).

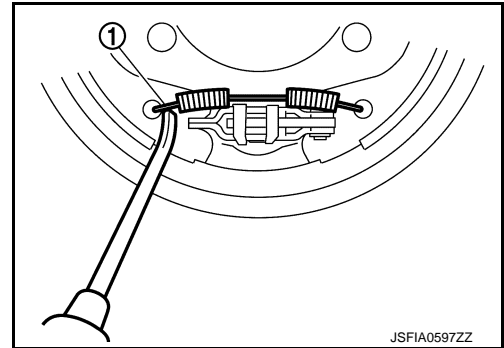

INSTALLATION

Note the following, install in the reverse order of removal.

- Apply PBC (Poly Butyl Cuprysil) grease or silicone-based grease to the part ① of back plate.

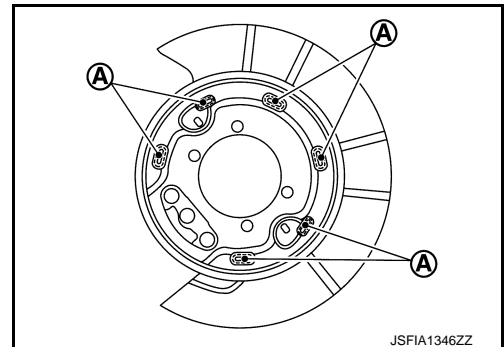

- Apply PBC (Poly Butyl Cuprysil) grease or silicone-based grease to the part ① of brake shoe.
- The parking brake shoes for the front wheels are made of different materials from those for the rear wheels. Never misidentify them when removing and replacing.

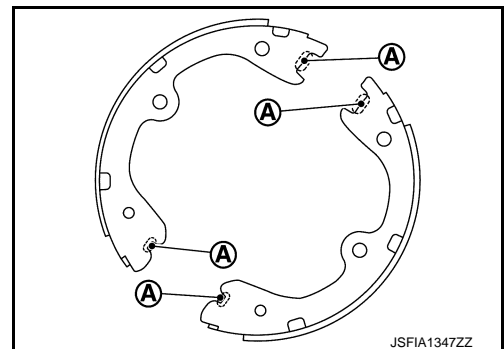

A
B
C
D
E
PB
G
H
I
J
K
L
M
N
O
P

PARKING BRAKE SHOE

< REMOVAL AND INSTALLATION >

- Assemble adjusters so that threaded part is expanded when rotating it in the direction shown by arrow (↶).

Ⓐ: For right side brake

Ⓑ: For left side brake

↶: Vehicle front

↶: Adjuster expands

- Shorten adjuster by rotating it.

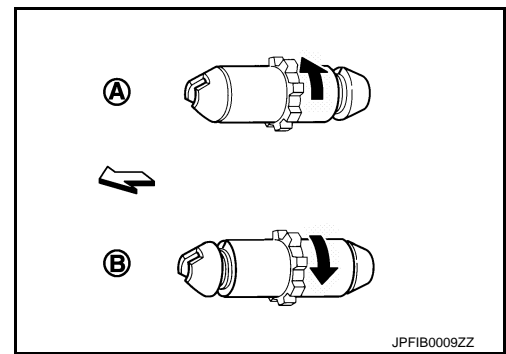

- When disassembling adjuster ①, apply PBC (Poly Butyl Cuprysil) grease or silicone- based grease to part Ⓐ of adjuster.

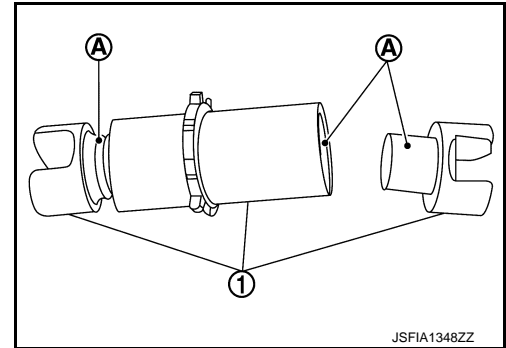

- Check the component parts of parking brake shoe assembly are installed properly.
- Check brake shoe sliding surface and drum inner surface for grease. Wipe it off if it adhere on the surfaces.
- Perform adjustment after installation. Refer to [PB-14, "Inspection and Adjustment"](#).

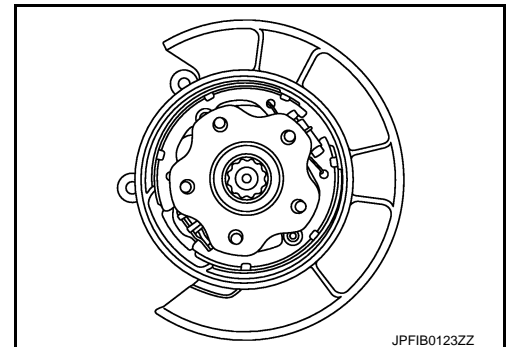

INFOID:000000011285686

Inspection and Adjustment

INSPECTION AFTER REMOVAL

Lining Thickness Inspection

Check thickness (A) of lining.

A : Refer to [PB-16, "Parking Drum Brake"](#).

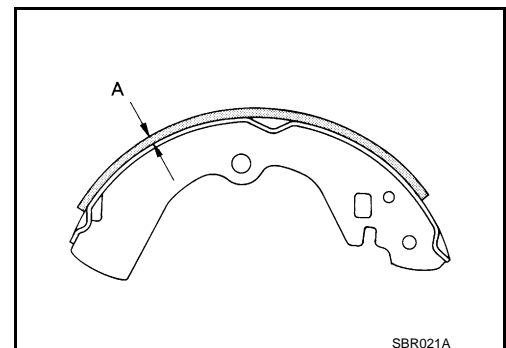

Drum Inner Diameter Inspection

PARKING BRAKE SHOE

< REMOVAL AND INSTALLATION >

Check inner diameter (B) of drum.

B : Refer to [PB-16, "Parking Drum Brake"](#).

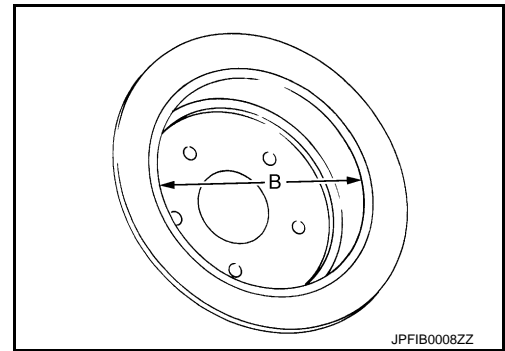

Other Inspections

Check the following items, and replace the parts if necessary.

- Parking brake shoe for excessive wear, damage, and peeling.
- Anti-rattle pin and retainer for excessive wear, damage and rust.
- Adjuster spring, return spring and anti-rattle spring for settling, excessive wear, damage, and rust.
- Adjuster for smoothness.
- Toggle lever for excessive wear, damage and rust.
- Visually check inside of the drum for excessive wear, cracks, and damage with a pair of vernier calipers.

ADJUSTMENT AFTER INSTALLATION

1. Adjust the parking brake pedal stroke. Refer to [PB-6, "Inspection and Adjustment"](#).
2. Rotate the disc rotor to check that there is no drag. Install the plug. If any drag is found, follow the procedure described below.
 - a. Adjust parking brake stroke again.
 - b. Check rear disc brake.
 - Brake caliper 1 piston type: Refer to [BR-72, "BRAKE CALIPER ASSEMBLY \(1 PISTON TYPE\) : Inspection"](#).
 - Brake caliper 2 piston type: Refer to [BR-76, "BRAKE CALIPER ASSEMBLY \(2 PISTON TYPE\) : Inspection"](#).

SERVICE DATA AND SPECIFICATIONS (SDS)

< SERVICE DATA AND SPECIFICATIONS (SDS)

SERVICE DATA AND SPECIFICATIONS (SDS)

SERVICE DATA AND SPECIFICATIONS (SDS)

Parking Drum Brake

INFOID:0000000011285687

Unit: mm (in)

| Item | | Limit |
|-------------------------------|---------------------|-------------|
| Brake lining | Wear thickness | 1.5 (0.059) |
| Drum (disc of inner diameter) | Wear inner diameter | 191 (7.52) |

Parking Brake Control

INFOID:0000000011285688

| | |
|---|---------------|
| Number of notches [under force of 196 N (20 kg, 44 lb)] | 2 – 3 notches |
| Number of notches when brake warning lamp turns ON | 1 notch |