

SECTION **SB**
SEAT BELT

A
B
C
D
E
F
G
SB
I
J
K
L
M
N
O
P

CONTENTS

PRECAUTION	2	REMOVAL AND INSTALLATION	8
PRECAUTIONS	2	FRONT SEAT BELT	8
Precaution for Supplemental Restraint System (SRS) "AIR BAG" and "SEAT BELT PRE-TENSIONER"	2	Exploded View	8
Precautions for Removing Battery Terminal	2	SEAT BELT RETRACTOR	8
Precaution for Seat Belt Service	3	SEAT BELT RETRACTOR : Removal and Installation	9
SYSTEM DESCRIPTION	4	SEAT BELT RETRACTOR : Inspection	10
COMPONENT PARTS	4	SEAT BELT BUCKLE	12
Seat belt pre-tensioner with Load limiter	4	SEAT BELT BUCKLE : Removal and Installation....	12
Double pre-tensioner seat belt	5	SEAT BELT BUCKLE : Inspection	12
Seat belt warning lamp	5	REAR SEAT BELT	13
Seat belt warning chime	6	Exploded View	13
SYSTEM	7	SEAT BELT RETRACTOR	14
WARNING/INDICATOR/CHIME LIST	7	SEAT BELT RETRACTOR : Removal and Installation	14
WARNING/INDICATOR/CHIME LIST : Warning Lamp/Indicator Lamp	7	SEAT BELT RETRACTOR : Inspection	14
WARNING/INDICATOR/CHIME LIST : Warning Chime	7	SEAT BELT BUCKLE	15
		SEAT BELT BUCKLE : Removal and Installation....	15
		SEAT BELT BUCKLE : Inspection	16

PRECAUTIONS

< PRECAUTION >

PRECAUTION

PRECAUTIONS

Precaution for Supplemental Restraint System (SRS) "AIR BAG" and "SEAT BELT PRE-TENSIONER"

INFOID:000000012793963

The Supplemental Restraint System such as "AIR BAG" and "SEAT BELT PRE-TENSIONER", used along with a front seat belt, helps to reduce the risk or severity of injury to the driver and front passenger for certain types of collision. This system includes seat belt switch inputs and dual stage front air bag modules. The SRS system uses the seat belt switches to determine the front air bag deployment, and may only deploy one front air bag, depending on the severity of a collision and whether the front occupants are belted or unbelted. Information necessary to service the system safely is included in the "SRS AIR BAG" and "SEAT BELT" of this Service Manual.

WARNING:

Always observe the following items for preventing accidental activation.

- To avoid rendering the SRS inoperative, which could increase the risk of personal injury or death in the event of a collision that would result in air bag inflation, it is recommended that all maintenance and repair be performed by an authorized NISSAN/INFINITI dealer.
- Improper repair, including incorrect removal and installation of the SRS, can lead to personal injury caused by unintentional activation of the system. For removal of Spiral Cable and Air Bag Module, see "SRS AIR BAG".
- Never use electrical test equipment on any circuit related to the SRS unless instructed to in this Service Manual. SRS wiring harnesses can be identified by yellow and/or orange harnesses or harness connectors.

PRECAUTIONS WHEN USING POWER TOOLS (AIR OR ELECTRIC) AND HAMMERS

WARNING:

Always observe the following items for preventing accidental activation.

- When working near the Air Bag Diagnosis Sensor Unit or other Air Bag System sensors with the ignition ON or engine running, never use air or electric power tools or strike near the sensor(s) with a hammer. Heavy vibration could activate the sensor(s) and deploy the air bag(s), possibly causing serious injury.
- When using air or electric power tools or hammers, always switch the ignition OFF, disconnect the battery or batteries, and wait at least 3 minutes before performing any service.

Precautions for Removing Battery Terminal

INFOID:000000013472899

When disconnecting the battery terminal, pay attention to the following.

- Always use a 12V battery as power source.
- Never disconnect battery terminal while engine is running.
- When removing the 12V battery terminal, turn OFF the ignition switch and wait at least 30 seconds.
- For vehicles with the engine listed below, remove the battery terminal after a lapse of the specified time:

BR08DE	: 4 minutes	V9X engine	: 4 minutes
D4D engine	: 20 minutes	YD25DDTi	: 2 minutes
HR09DET	: 12 minutes	YS23DDT	: 4 minutes
HRA2DDT	: 12 minutes	YS23DDTT	: 4 minutes
K9K engine	: 4 minutes	ZD30DDTi	: 60 seconds
M9R engine	: 4 minutes	ZD30DDTT	: 60 seconds
R9M engine	: 4 minutes		

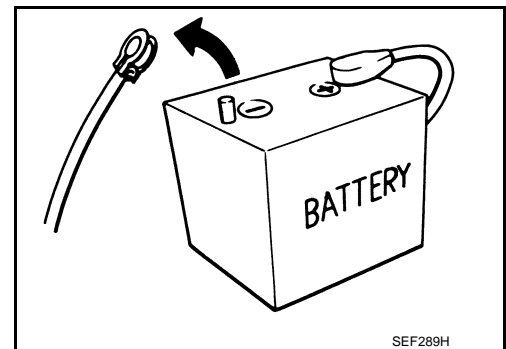

NOTE:

ECU may be active for several tens of seconds after the ignition switch is turned OFF. If the battery terminal is removed before ECU stops, then a DTC detection error or ECU data corruption may occur.

- After high-load driving, if the vehicle is equipped with the V9X engine, turn the ignition switch OFF and wait for at least 15 minutes to remove the battery terminal.

NOTE:

PRECAUTIONS

< PRECAUTION >

- Turbocharger cooling pump may operate in a few minutes after the ignition switch is turned OFF.
- Example of high-load driving
 - Driving for 30 minutes or more at 140 km/h (86 MPH) or more.
 - Driving for 30 minutes or more on a steep slope.
- For vehicles with the 2-batteries, be sure to connect the main battery and the sub battery before turning ON the ignition switch.

A

B

C

D

E

F

G

SB

I

J

K

L

M

N

O

P

NOTE:

If the ignition switch is turned ON with any one of the terminals of main battery and sub battery disconnected, then DTC may be detected.

- After installing the 12V battery, always check "Self Diagnosis Result" of all ECUs and erase DTC.

NOTE:

The removal of 12V battery may cause a DTC detection error.

Precaution for Seat Belt Service

INFOID:000000012793965

CAUTION:

- Before removing the front seat belt pre-tensioner assembly, turn the ignition switch off, disconnect battery negative terminal and wait at least 3 minutes.
- Never use electrical test equipment for front seat belt pre-tensioner connector.
- After replacing or reinstalling front seat belt pre-tensioner assembly, or reconnecting front seat belt pre-tensioner connector, check the system function. Refer to [SRC-16, "Description"](#).
- Never use disassembled buckle or seat belt assembly.
- Replace anchor bolts if they are deformed or worn out.
- Never oil tongue and buckle.
- If any component of seat belt assembly is questionable, do not repair. Replace the entire seat belt assembly.
- If webbing is cut, frayed or damaged, replace seat belt assembly.
- When replacing seat belt assembly, use a genuine NISSAN seat belt assembly.

AFTER A COLLISION

WARNING:

Inspect all seat belt assemblies including retractors and attached hardware after any collision.

NISSAN recommends that all seat belt assemblies in use during a collision be replaced unless the collision was minor and the belts show no damage and continue to operate properly. Failure to do so could result in serious personal injury in an accident. Seat belt assemblies not in use during a collision should also be replaced if either damage or improper operation is noted. Seat belt pre-tensioners should be replaced even if the seat belts are not in use during a frontal collision in which the air bags are deployed.

Replace any seat belt assembly (including anchor bolts) if:

- The seat belt was in use at the time of a collision (except for minor collisions and the belts, retractors and buckles show no damage and continue to operate properly).
- The seat belt was damaged in an accident (i.e. torn webbing, bent retractor or guide).
- The seat belt attaching point was damaged in an accident. Inspect the seat belt attaching area for damage or distortion and repair as necessary before installing a new seat belt assembly.
- Anchor bolts are deformed or worn out.
- The front seat belt pre-tensioner should be replaced even if the seat belts are not in use during the collision in which the air bags are deployed.

COMPONENT PARTS

< SYSTEM DESCRIPTION >

SYSTEM DESCRIPTION

COMPONENT PARTS

Seat belt pre-tensioner with Load limiter

INFOID:000000012793966

DESCRIPTION

The seat belt system is equipped with pre-tensioner mechanism, load limiter mechanism, and ELR mechanism.

STRUCTURE

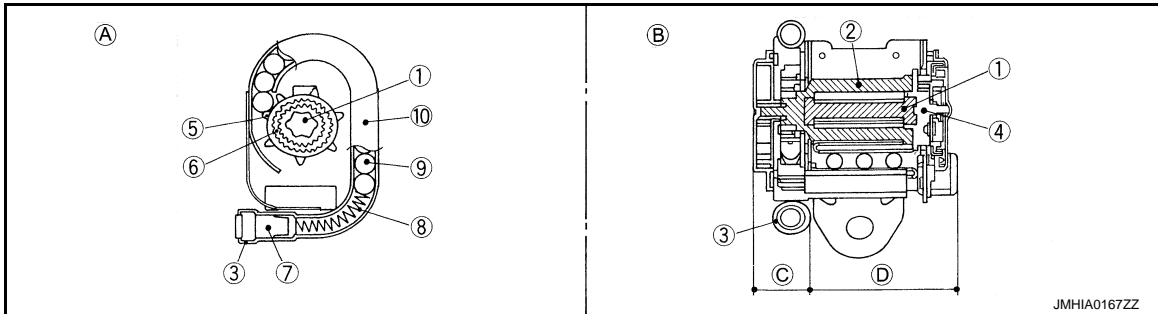

- | | | |
|---|---------------------------------------|-----------------------------------|
| ① ELR shaft (torsion bar) | ② Bobbin | ③ Manifold case |
| ④ Lock portion | ⑤ Ring gear | ⑥ Pinion gear |
| ⑦ Gas generator | ⑧ Spring | ⑨ Ball |
| ⑩ Pipe | | |
| Ⓐ Pre-tensioner mechanism cross section | Ⓑ ELR mechanism portion cross section | Ⓒ Pre-tensioner mechanism portion |
| Ⓓ Load limiter portion | | |

PRE-TENSIONER MECHANISM

- In a frontal collision that exceeds the specified limit, air bag sensor unit detects the collision, transmits an electrical signal to gas generator ③ in manifold case, and activates gas generator. Gas is generated.
- The pressure of the generated gas moves the ball ④ inside of pipe ⑥. The ball then presses ring gear ② which is engaged to the pinion gear ①.
- The rotation of the ring gear rotates the shaft ⑤ in the retracting direction of the seat belt. Seat belt is retracted.

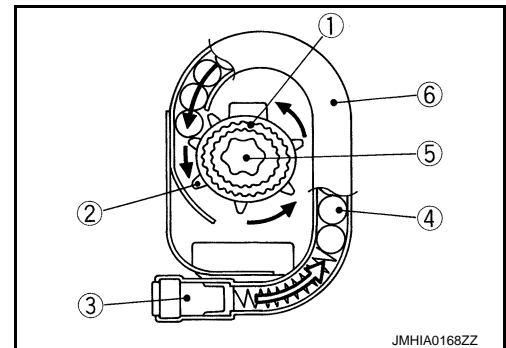

LOAD LIMITER (ELR) MECHANISM

- In a collision, when ELR shaft ② is locked, a load caused by impact is applied to webbing ①
- When a load is continuously applied to webbing and reaches or exceeds the specified level, a rotating force is applied to ELR shaft that is engaged to lock portion ④ and bobbin ③. ELR shaft twists.
- As ELR shaft is twisted, webbing is pulled out while keeping a certain level of tension and easing the impact to the chest of front seat passenger.

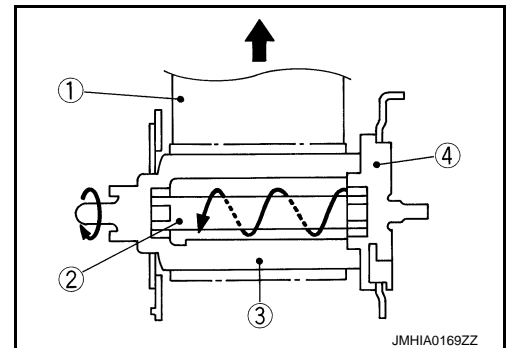

COMPONENT PARTS

< SYSTEM DESCRIPTION >

Double pre-tensioner seat belt

INFOID:000000012793967

DESCRIPTION

The system combines lap pre-tensioner mechanism for lumbar seat belt and pre-tensioner seat belt with load limiter. The system upgrades passenger restraint by reducing lumbar movement during a frontal collision.

LAP PRE-TENSIONER MECHANISM

- In a frontal collision that exceeds the specified limit, air bag sensor unit detects the collision, transmits an electrical signal to gas generator ① in pipe, and activates gas generator. Gas is generated. The pressure of the generated gas moves the piston inside of pipe toward pipe front direction, and retracts wire.
- Lap anchor is installed to end of the wire and end of seat belt is connected to lap anchor. The wire therefore retracts seat belt.
- When piston stops, clutch mechanism integrated to piston prevents piston from moving in the original direction. Wire and lap anchor therefore remain in the retracted status.

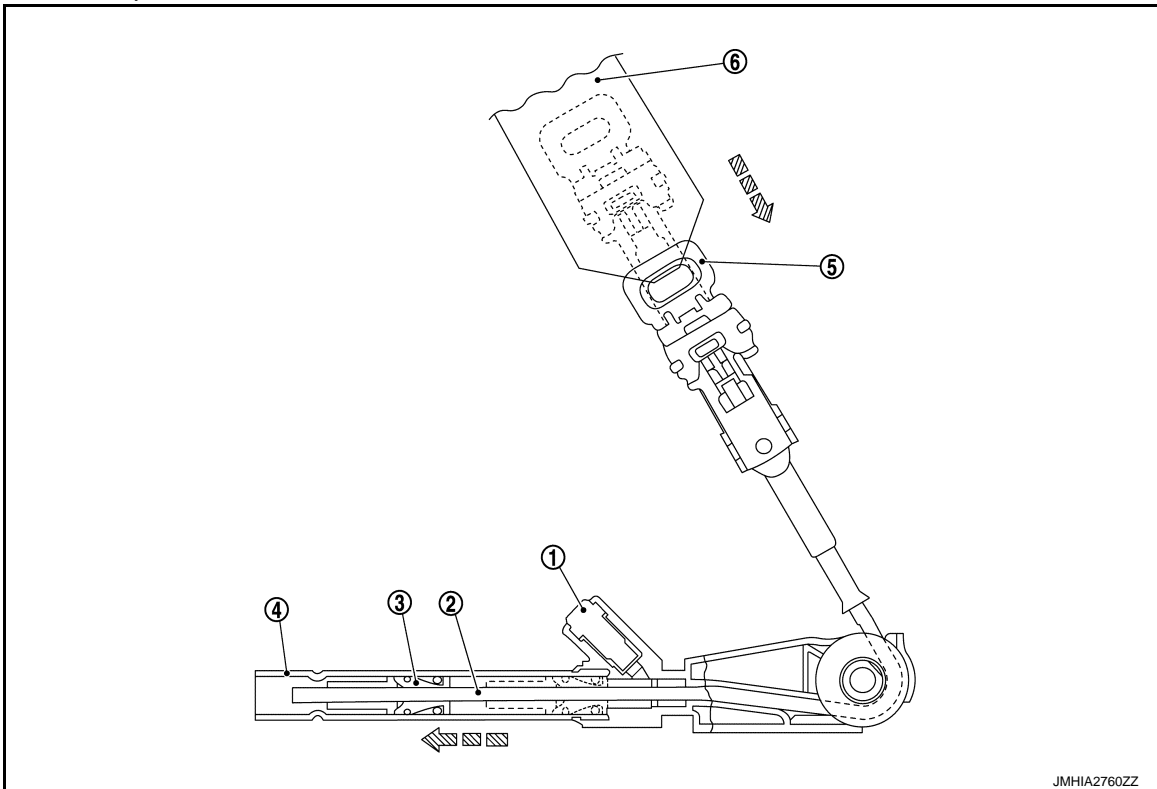

① Gas generator

② Wire

③ Piston

④ Pipe

⑤ Lap anchor

⑥ Seat belt

Seat belt warning lamp

INFOID:000000012793968

Seat belt warning lamp on combination meter turns ON during a period when power switch is turned ON until front seat belts are fastened. Seat belt warning lamp turns OFF when seat belt is fastened. Seat belt warning lamp turns ON again when seat belt is unfastened.



COMPONENT PARTS

< SYSTEM DESCRIPTION >

Seat belt warning chime

INFOID:000000012793969

Seat belt warning chime sounds for approximately 90 seconds when the vehicle speed is approximately 15 km/h (9.3 MPH) or more while front seat belts are not fastened. Seat belt warning chime stops when seat belt is fastened.

SYSTEM

< SYSTEM DESCRIPTION >

SYSTEM

WARNING/INDICATOR/CHIME LIST

WARNING/INDICATOR/CHIME LIST : Warning Lamp/Indicator Lamp

INFOID:000000012793970

Item	Design	Reference
Seat belt warning lamp		For layout, refer to MWI-9, "METER SYSTEM : Design" .
		For function, refer to MWI-43, "WARNING LAMPS/INDICATOR LAMPS : Seat Belt Warning Lamp" .

WARNING/INDICATOR/CHIME LIST : Warning Chime

INFOID:000000012793971

Item	Reference
Seat belt warning	Refer to WCS-19, "WARNING CHIME : Seat Belt Warning" .

A
B
C
D
E
F
G
I
J
K
L
M
N
O
P

SB

FRONT SEAT BELT

< REMOVAL AND INSTALLATION >

REMOVAL AND INSTALLATION

FRONT SEAT BELT

Exploded View

INFOID:000000012793972

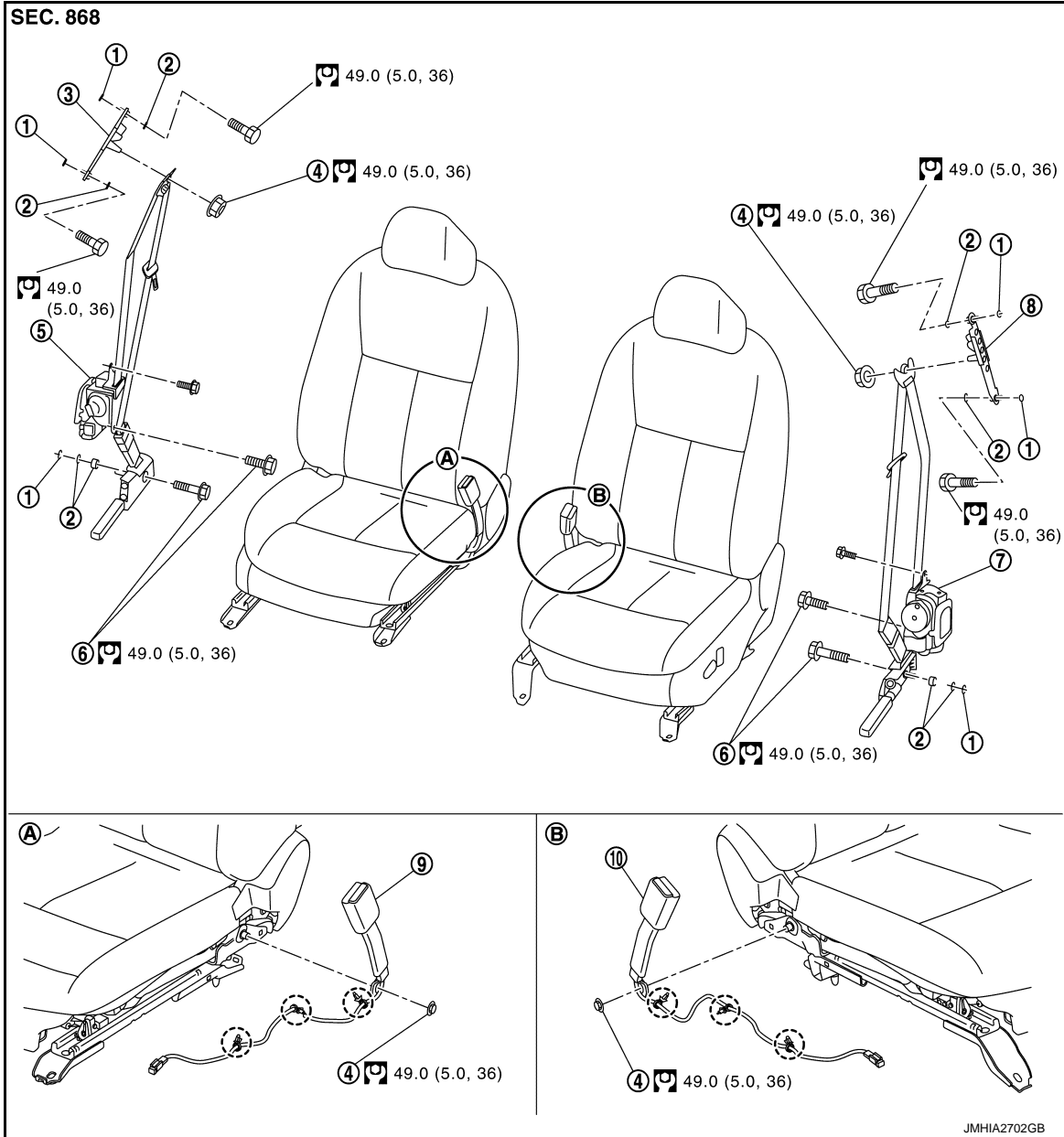

- | | | |
|--|---|-------------------------------------|
| ① Retaining washer | ② Spacer | ③ Seat belt adjuster RH |
| ④ Anchor nut | ⑤ Seat belt pre-tensioner retractor assembly (Passenger side) | ⑥ Anchor bolt |
| ⑦ Seat belt pre-tensioner retractor assembly (Driver side) | ⑧ Seat belt adjuster LH | ⑨ Seat belt buckle (Passenger side) |
| ⑩ Seat belt buckle (Driver side) | | |
- : Clip
 □ : N·m (kg-m, ft-lb)

SEAT BELT RETRACTOR

FRONT SEAT BELT

< REMOVAL AND INSTALLATION >

SEAT BELT RETRACTOR : Removal and Installation

INFOID:000000012793973

WARNING:

Before servicing, turn ignition switch OFF, disconnect battery negative terminal and wait for 3 minutes or more (discharges electricity held in the additional power supply circuit of the air bag diagnosis sensor unit).

REMOVAL

Seat Belt Models with Lap Pre-tensioner

1. Remove lap pre-tensioner.
 - a. Slide seat to the foremost position.
 - b. Insert flat-bladed screwdriver (A) into each hole on lap pre-tensioner buckle back side, spread inner metal portion as shown, and pull out lap pre-tensioner tongue ① while inserting flat-bladed screwdriver (B) into the hole on lap pre-tensioner buckle according to numerical order 1→3 indicated by arrows as shown in the figure.

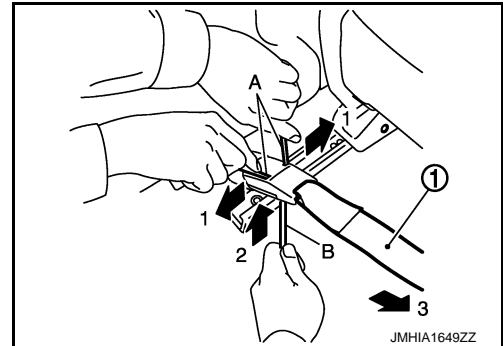

- c. Remove center pillar lower garnish. Refer to [INT-32. "CENTER PILLAR LOWER GARNISH : Removal and Installation"](#).
 - d. Disconnect lap pre-tensioner harness connector.

CAUTION:

- For installing/removing lap pre-tensioner harness connector, insert thin screwdriver wrapped in tape into notch, lift lock and remove connector.
- Install connector with lock raised, and push lock into connector.
- After installing the connector, check that the lock is pushed securely into it.

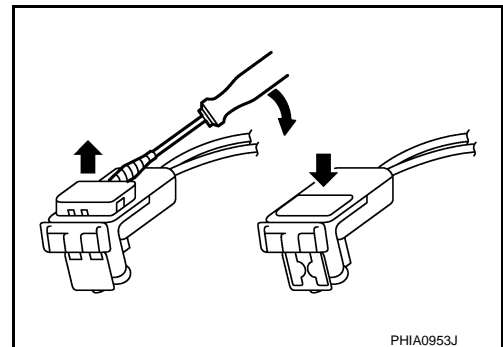

- e. Remove mounting anchor bolt of the lap pre-tensioner.
 2. Remove shoulder anchor.
 - a. Remove center pillar upper garnish. Refer to [INT-33. "CENTER PILLAR UPPER GARNISH : Removal and Installation"](#).
 - b. Remove mounting anchor nut of shoulder anchor.
 3. Remove seat belt pre-tensioner retractor.
 - a. Disconnect pre-crash seat belt harness connector. (with pre-crash seat belt)
 - b. Disconnect seat belt pre-tensioner harness connector.

CAUTION:

FRONT SEAT BELT

< REMOVAL AND INSTALLATION >

- For installing/removing seat belt pre-tensioner harness connector, insert thin screwdriver wrapped in tape into notch, lift lock and remove connector.
- Install connector with lock raised, and push lock into connector.
- After installing the connector, check that the lock is pushed securely into it.

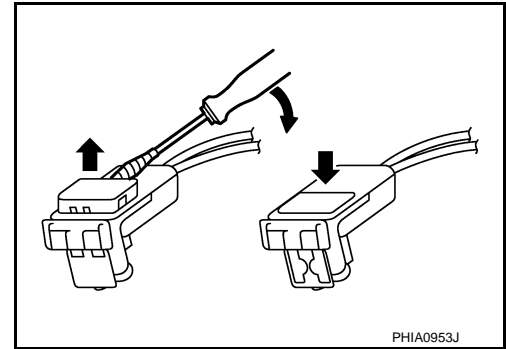

- c. Remove the mounting bolt and mounting anchor bolt of the seat belt pre-tensioner retractor.

CAUTION:

Never place seat belt pre-tensioner and lap pre-tensioner in an area where the temperature reaches 80°C (176°F) or more.

4. Remove mounting bolts of the seat belt adjuster.

INSTALLATION

Install in the reverse order of removal.

SEAT BELT RETRACTOR : Inspection

INFOID:000000012793974

AFTER A COLLISION

WARNING:

Inspect all seat belt assemblies including retractors and attached hardware after any collision.

NISSAN/INFINITI recommends that all seat belt assemblies in use during a collision be replaced unless the collision was minor and the belts show no damage and continue to operate properly. Failure to do so could result in serious personal injury in an accident. Seat belt assemblies not in use during a collision should also be replaced if either damage or improper operation was noted. Seat belt pre-tensioners should be replaced even if the seat belts were not in use during a frontal collision in which the air bags were deployed.

Replace any seat belt assembly (including anchor bolts) if:

- The seat belt is in use at the time of a collision (except for minor collisions and the belts, retractors and buckles show no damage and continue to operate properly).
- The seat belt is damaged in an accident (i.e. torn webbing, bent retractor or guide, etc.).
- The seat belt attaching point is damaged in an accident. Inspect the seat belt attaching area for damage or distortion and repair if necessary before installing a new seat belt assembly.
- Anchor bolts are deformed or worn out.
- The seat belt pre-tensioners must be replaced even if the seat belts were not in use during the collision in which the air bags were deployed.

PRELIMINARY CHECKS

1. Check the seat belt warning lamp for proper operation as per the following:
 - a. Turn ignition switch ON. The seat belt warning lamp should illuminate.
 - b. Fasten driver seat belt. The seat belt warning lamp should turn OFF.
2. If the air bag warning lamp turns ON or blinks indicating a system malfunction, perform self-diagnosis using CONSULT or air bag warning lamp. Refer to [SRC-16, "Description"](#).
3. Check that the seat belt retractor, seat belt anchor and buckle bolts are tightened firmly.
4. Check the shoulder seat belt guide and shoulder belt height adjuster for front seats. Check that guide swivels freely and that webbing lays flat and does not bind in guide. Check that height adjuster operates properly and holds securely.
5. Check retractor operation:
 - a. Fully extend the seat belt webbing and check for twists, tears or other damage.
 - b. Allow the seat belt to retract. Check that webbing returns smoothly and completely into the retractor. If the seat belt does not return smoothly, wipe the inside of the loops with a clean paper cloth. Dirt build-up in the loops of the upper anchors can cause the seat belts to retract slowly.

FRONT SEAT BELT

< REMOVAL AND INSTALLATION >

- c. Fasten the seat belt. Check that seat belt returns smoothly and completely to the retractor. If the webbing does not return smoothly, the cause may be an accumulation of dust or dirt. Use the "SEAT BELT TAPE SET" and perform the following steps. A

Inspect The Front Seat Belt Shoulder Anchor

1. Pull the seat belt out to a length of 500 mm (19.69 in) or more. B
2. Fix the seat belt at the center pillar webbing opening with a clip or other device.
3. Pass a thin wire through the shoulder anchor webbing opening. Hold both ends of the wire and pull it tightly while moving it up and down several times along the webbing opening surface to remove dirt stuck there. C
4. Any dirt that cannot be removed with the wire can be removed by cleaning the opening with a clean cloth.
5. Apply tape at the point where the webbing contacts the shoulder anchor webbing opening. D

NOTE:

Apply the tape so that there is no slack or wrinkling.

6. Remove the clip fixing the seat belt and check that the webbing returns smoothly. E
6. Repeat steps above if necessary to check the other seat belts.

SEAT BELT RETRACTOR ON-VEHICLE CHECK F

Emergency Locking Retractors (ELR)

NOTE:

All seat belt retractors are Emergency Locking Retractors (ELR) type. In an emergency (sudden stop) the retractor will lock and prevent the webbing from extending any further. G

Check the seat belt retractors with the following test(s) to determine if a retractor assembly is operating properly.

ELR Function Stationary Check

Grasp the shoulder webbing and pull forward quickly. The retractor should lock and prevent the belt from extending further. I

ELR Function Moving Check

WARNING:

Perform the following test in a safe, open area clear of other vehicles and obstructions (for example, a large, empty parking lot). Road surface must be paved and dry. Never perform the following test on wet or gravel roads or on public streets and highways. This could result in an accident and serious personal injury. The driver and passenger must be prepared to brace themselves in the event that the retractor does not lock. J

1. Fasten driver seat belt. Buckle a passenger into the seat for the belt that is to be tested.
2. Proceed to the designated safe area. L
3. Drive the vehicle at approximately 16 km/h (10 MPH). Notify any passengers of a pending sudden stop and the driver and passenger must be prepared to brace themselves in the event that the retractor does not lock. Apply brakes firmly and make a very hard stop. M

During stopping, seat belts should lock and not be extended. If the seat belt retractor assembly does not lock, perform the retractor off-vehicle check.

SEAT BELT RETRACTOR OFF-VEHICLE CHECK N

1. Remove front seat belt retractor assembly. Refer to [SB-9, "SEAT BELT RETRACTOR : Removal and Installation"](#). O
2. Slowly pull out webbing while tilting the retractor assembly forward from the mounted position without twisting the retractor assembly as shown in the figure. P

FRONT SEAT BELT

< REMOVAL AND INSTALLATION >

- The webbing can be pulled out when the angle (A) is 15 degrees or less.
- The webbing cannot be pulled out when the angle (B) is 27 degrees or more.

A and B : Tilting angles

← : Vehicle front

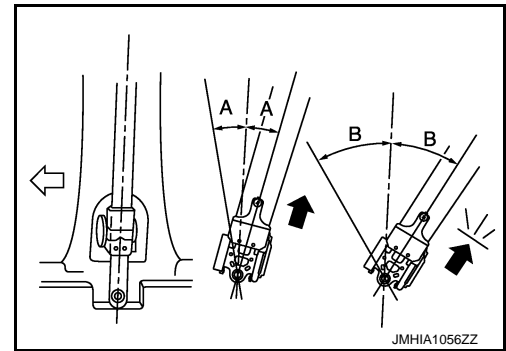

3. Replace the seat belt assembly if it does not operate normally.

SEAT BELT BUCKLE

SEAT BELT BUCKLE : Removal and Installation

INFOID:000000012793975

REMOVAL

1. Remove front seat from the vehicle. Refer to [SE-83, "Removal and Installation"](#).
2. Disconnect seat belt buckle harness connector and harness clip.
3. Remove mounting anchor nut, and then remove seat belt buckle from front seat.

INSTALLATION

Install in the reverse order of removal.

SEAT BELT BUCKLE : Inspection

INFOID:000000012793976

AFTER A COLLISION

WARNING:

Inspect all seat belt assemblies including retractors and attached hardware after any collision. NISSAN/INFINITI recommends that all seat belt assemblies in use during a collision be replaced unless the collision was minor and the belts show no damage and continue to operate properly. Failure to do so could result in serious personal injury in an accident. Seat belt assemblies not in use during a collision should also be replaced if either damage or improper operation was noted. Seat belt pre-tensioners should be replaced even if the seat belts were not in use during a frontal collision in which the air bags were deployed.

Replace any seat belt assembly (including anchor bolts) if:

- The seat belt is in use at the time of a collision (except for minor collisions and the belts, retractors and buckles show no damage and continue to operate properly).
- The seat belt is damaged in an accident (i.e. torn webbing, bent retractor or guide, etc.).
- The seat belt attaching point is damaged in an accident. Inspect the seat belt attaching area for damage or distortion and repair if necessary before installing a new seat belt assembly.
- Anchor bolts are deformed or worn out.
- The seat belt pre-tensioner must be replaced even if the seat belts were not in use during the collision in which the air bags were deployed.

PRELIMINARY CHECKS

1. Check the seat belt warning lamp for proper operation as per the following:
 - a. Turn ignition switch ON. The seat belt warning lamp should illuminate.
 - b. Fasten driver seat belt. The seat belt warning lamp should turn OFF.
2. If the air bag warning lamp turns ON or blinks indicating a system malfunction, perform self-diagnosis using CONSULT or air bag warning lamp. Refer to [SRC-16, "Description"](#).
3. Check that the seat belt retractor, seat belt anchor and buckle bolts are tightened firmly.
4. Repeat steps above if necessary to check the other seat belts.

REAR SEAT BELT

< REMOVAL AND INSTALLATION >

REAR SEAT BELT

Exploded View

INFOID:000000012793977

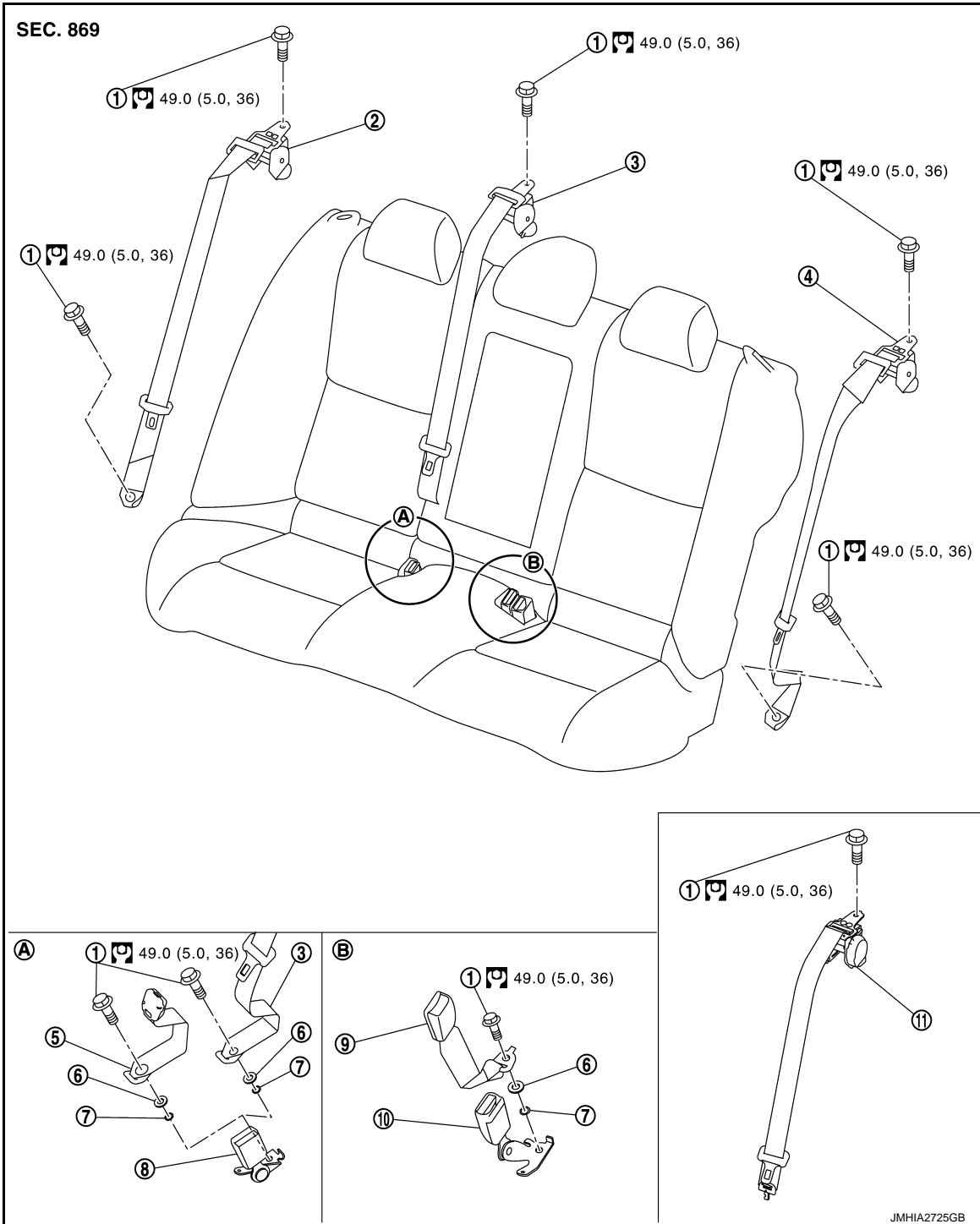



- | | | |
|-----------------------------------|---|---|
| ① Anchor bolt | ② Seat belt retractor assembly RH | ③ Center seat belt retractor assembly (Bench seat models) |
| ④ Seat belt retractor assembly LH | ⑤ Center seat belt assembly outer (6:4 Separate seat models) | ⑥ Spacer |
| ⑦ Retaining washer | ⑧ Seat belt buckle RH | ⑨ Center seat belt buckle |
| ⑩ Seat belt buckle LH | ⑪ Center seat belt assembly tongue (6:4 Separate seat models) | |

A
B
C
D
E
F
G
SB
I
J
K
L
M
N
O
P

REAR SEAT BELT

< REMOVAL AND INSTALLATION >

 : Always replace after every disassembly.

 : N·m (kg·m, ft·lb)

SEAT BELT RETRACTOR

SEAT BELT RETRACTOR : Removal and Installation

INFOID:000000012793978

WARNING:

Before servicing, turn ignition switch OFF, disconnect battery negative terminal and wait for 3 minutes or more (discharges electricity held in the additional power supply circuit of the air bag diagnosis sensor unit). (Only for models with seat belt pre-tensioner)

REMOVAL

Seat Belt LH/Seat Belt RH

1. Remove rear parcel shelf finisher. Refer to [INT-37, "Removal and Installation"](#).
2. Remove seat belt retractor assembly mounting anchor bolt.
3. Remove seat belt retractor assembly from the vehicle.

Center Seat Belt

1. Disconnect center seat belt assembly tongue and center seat belt assembly outer. (6:4 separate seat)
2. Remove mounting anchor bolt, and then remove center seat belt assembly outer. (6:4 separate seat)
3. Remove rear parcel shelf finisher. Refer to [INT-37, "Removal and Installation"](#).
4. Remove mounting anchor bolt, and then remove center seat belt retractor assembly. (Bench seat)
5. Remove mounting anchor bolt, and then remove center seat belt assembly tongue. (6:4 separate seat)

INSTALLATION

Install in the reverse order of removal.

CAUTION:

Never reuse pillar insulator after removal, replace with the pillar insulator.

SEAT BELT RETRACTOR : Inspection

INFOID:000000012793979

AFTER A COLLISION

WARNING:

Inspect all seat belt assemblies including retractors and attached hardware after any collision. NISSAN/INFINITI recommends that all seat belt assemblies in use during a collision be replaced unless the collision was minor and the belts show no damage and continue to operate properly. Failure to do so could result in serious personal injury in an accident. Seat belt assemblies not in use during a collision should also be replaced if either damage or improper operation was noted. Seat belt pre-tensioners should be replaced even if the seat belts were not in use during a frontal collision in which the air bags were deployed.

Replace any seat belt assembly (including anchor bolts) if:

- The seat belt is in use at the time of a collision (except for minor collisions and the belts, retractors and buckles show no damage and continue to operate properly).
- The seat belt is damaged in an accident (i.e. torn webbing, bent retractor or guide, etc.).
- The seat belt attaching point is damaged in an accident. Inspect the seat belt attaching area for damage or distortion and repair if necessary before installing a new seat belt assembly.
- Anchor bolts are deformed or worn out.

PRELIMINARY CHECKS

1. Check that the seat belt retractor, seat belt anchor and buckle bolts are tightened firmly.
2. Check retractor operation:
 - a. Fully extend the seat belt webbing and check for twists, tears or other damage.
 - b. Allow the seat belt to retract. Check that webbing returns smoothly and completely into the retractor. If the seat belt does not return smoothly, wipe the inside of the loops with a clean paper cloth. Dirt build-up in the loops of that upper anchors can cause the seat belts to retract slowly.
3. Repeat steps above if necessary to check the other seat belts.

REAR SEAT BELT

< REMOVAL AND INSTALLATION >

SEAT BELT RETRACTOR ON-VEHICLE CHECK

Emergency Locking Retractors (ELR)

NOTE:

All seat belt retractors are Emergency Locking Retractors (ELR) type. In an emergency (sudden stop) the retractor will lock and prevent the webbing from extending any further. Check the seat belt retractors with the following test(s) to determine if a retractor assembly is operating properly.

ELR Function Stationary Check

Grasp the shoulder webbing and pull forward quickly. The retractor should lock and prevent the belt from extending further.

ELR Function Moving Check

WARNING:

Perform the following test in a safe, open area clear of other vehicles and obstructions (for example, a large, empty parking lot). Road surface must be paved and dry. Never perform the following test on wet or gravel roads or on public streets and highways. This could result in an accident and serious personal injury. The driver and passenger must be prepared to brace themselves in the event that the retractor does not lock.

1. Fasten driver seat belt. Buckle a passenger into the seat for the belt that is to be tested.
2. Proceed to the designated safe area.
3. Drive the vehicle at approximately 16 km/h (10 MPH). Notify any passengers of a pending sudden stop and the driver and passenger must be prepared to brace themselves in the event that the retractor does not lock. Apply brakes firmly and make a very hard stop.

During stopping, seat belts should lock and not be extended. If the seat belt retractor assembly does not lock, perform the retractor off-vehicle check.

SEAT BELT RETRACTOR OFF-VEHICLE CHECK

1. Remove rear seat belt retractor assembly. Refer to [SB-14, "SEAT BELT RETRACTOR : Removal and Installation"](#).
2. Slowly pull out webbing while tilting the retractor assembly forward from the mounted position without twisting the retractor assembly as shown in the figure.
 - The webbing can be pulled out when the angle (A) is 15 degrees or less.
 - The webbing cannot be pulled out when the angle (B) is 27 degrees or more.

A and B : Tilting angles

↔ : Vehicle front

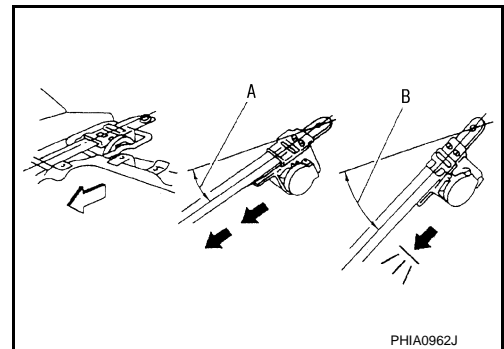

3. Replace the seat belt assembly if it does not operate normally.

SEAT BELT BUCKLE

SEAT BELT BUCKLE : Removal and Installation

INFOID:000000012793980

REMOVAL

1. Remove rear seat cushion from the vehicle. Refer to [SE-101, "SEAT CUSHION : Removal and Installation"](#) (Bench seat models) or [SE-110, "SEAT CUSHION : Removal and Installation"](#) (6:4 separate seat models).
2. Remove seat belt buckle mounting anchor bolt, and then remove seat belt buckle.

INSTALLATION

Install in the reverse order of removal.

REAR SEAT BELT

< REMOVAL AND INSTALLATION >

SEAT BELT BUCKLE : Inspection

INFOID:000000012793981

AFTER A COLLISION

WARNING:

Inspect all seat belt assemblies including retractors and attached hardware after any collision.

NISSAN/INFINITI recommends that all seat belt assemblies in use during a collision be replaced unless the collision was minor and the belts show no damage and continue to operate properly. Failure to do so could result in serious personal injury in an accident. Seat belt assemblies not in use during a collision should also be replaced if either damage or improper operation was noted. Seat belt pre-tensioners should be replaced even if the seat belts were not in use during a frontal collision in which the air bags were deployed.

Replace any seat belt assembly (including anchor bolts) if:

- The seat belt is in use at the time of a collision (except for minor collisions and the belts, retractors and buckles show no damage and continue to operate properly).
- The seat belt is damaged in an accident (i.e. torn webbing, bent retractor or guide, etc.).
- The seat belt attaching point is damaged in an accident. Inspect the seat belt attaching area for damage or distortion and repair if necessary before installing a new seat belt assembly.
- Anchor bolts are deformed or worn out.

PRELIMINARY CHECKS

1. Check that the seat belt retractor, seat belt anchor and buckle bolts are tightened firmly.
2. Repeat step above if necessary to check the other seat belts.