

# CCS

## SECTION

### CRUISE CONTROL SYSTEM

A  
B  
C

## CONTENTS

D  
E

<p><b>ICC</b></p> <p><b>PRECAUTION</b> ..... 4</p> <p><b>PRECAUTIONS</b> ..... 4</p> <p style="padding-left: 20px;">Precaution for Supplemental Restraint System (SRS) "AIR BAG" and "SEAT BELT PRE-TENSIONER" .....4</p> <p style="padding-left: 20px;">Precautions For Harness Repair .....4</p> <p style="padding-left: 20px;">ICC System Service .....5</p> <p><b>PREPARATION</b> ..... 6</p> <p><b>PREPARATION</b> ..... 6</p> <p style="padding-left: 20px;">Special Service Tools .....6</p> <p><b>SYSTEM DESCRIPTION</b> ..... 7</p> <p><b>COMPONENT PARTS</b> ..... 7</p> <p style="padding-left: 20px;">Component Parts Location .....7</p> <p style="padding-left: 20px;">ADAS Control Unit .....9</p> <p style="padding-left: 20px;">ICC Sensor .....9</p> <p style="padding-left: 20px;">ICC Steering Switch ..... 10</p> <p style="padding-left: 20px;">Brake Pedal Position Switch / Stop Lamp Switch.... 10</p> <p style="padding-left: 20px;">ICC Brake Hold Relay ..... 10</p> <p style="padding-left: 20px;">Combination Meter ..... 10</p> <p style="padding-left: 20px;">Driver Assistance Buzzer Control Module ..... 11</p> <p style="padding-left: 20px;">Driver Assistance Buzzer ..... 11</p> <p><b>SYSTEM</b> .....12</p> <p style="padding-left: 20px;">System Description ..... 12</p> <p style="padding-left: 20px;">Circuit Diagram ..... 15</p> <p style="padding-left: 20px;">Fail-safe (ADAS Control Unit) ..... 15</p> <p style="padding-left: 20px;">Fail-safe (ICC Sensor) ..... 16</p> <p><b>VEHICLE-TO-VEHICLE DISTANCE CONTROL MODE FUNCTION</b> ..... 16</p> <p style="padding-left: 20px;">VEHICLE-TO-VEHICLE DISTANCE CONTROL MODE FUNCTION : System Description ..... 16</p> <p><b>CONVENTIONAL (FIXED SPEED) CRUISE CONTROL MODE FUNCTION</b> ..... 18</p>	<p>CONVENTIONAL (FIXED SPEED) CRUISE CONTROL MODE FUNCTION : System Description .....18</p> <p><b>WARNING/INDICATOR/CHIME LIST</b> .....18</p> <p style="padding-left: 20px;">WARNING/INDICATOR/CHIME LIST : Warning/Indicator (On Information Display) ..... 18</p> <p><b>OPERATION</b> .....20</p> <p><b>VEHICLE-TO-VEHICLE DISTANCE CONTROL MODE FUNCTION</b> .....20</p> <p style="padding-left: 20px;">VEHICLE-TO-VEHICLE DISTANCE CONTROL MODE FUNCTION : Switch Name and Function ....20</p> <p style="padding-left: 20px;">VEHICLE-TO-VEHICLE DISTANCE CONTROL MODE FUNCTION : Menu Displayed by Pressing Each Switch .....20</p> <p><b>CONVENTIONAL (FIXED SPEED) CRUISE CONTROL MODE FUNCTION</b> .....24</p> <p style="padding-left: 20px;">CONVENTIONAL (FIXED SPEED) CRUISE CONTROL MODE FUNCTION : Switch Name and Function .....24</p> <p style="padding-left: 20px;">CONVENTIONAL (FIXED SPEED) CRUISE CONTROL MODE FUNCTION : Menu Displayed by Pressing Each Switch .....24</p> <p><b>HANDLING PRECAUTION</b> .....27</p> <p style="padding-left: 20px;">Precautions for Vehicle-to-Vehicle Distance Control Mode .....27</p> <p style="padding-left: 20px;">Precautions for Conventional (Fixed Speed) Cruise Control Mode .....29</p> <p><b>DIAGNOSIS SYSTEM (ADAS CONTROL UNIT)</b> .....30</p> <p style="padding-left: 20px;">On Board Diagnosis Function .....30</p> <p style="padding-left: 20px;">CONSULT Function (ICC/ADAS) .....31</p> <p><b>DIAGNOSIS SYSTEM (ICC SENSOR)</b> .....44</p> <p style="padding-left: 20px;">CONSULT Function (LASER/RADAR) .....44</p>
---	--

F  
G  
H  
I  
J  
K  
L  
M  
N



P

<b>DIAGNOSIS SYSTEM (DRIVER ASSISTANCE BUZZER CONTROL MODULE)</b> .....	46	Work Procedure [Conventional (Fixed Speed) Cruise Control Mode] .....	98
CONSULT Function (BSW/BUZZER) .....	46	<b>DTC/CIRCUIT DIAGNOSIS</b> .....	<b>101</b>
<b>ECU DIAGNOSIS INFORMATION</b> .....	<b>50</b>	<b>C1A00 CONTROL UNIT</b> .....	<b>101</b>
<b>ADAS CONTROL UNIT</b> .....	<b>50</b>	DTC Logic .....	101
Reference Value .....	50	Diagnosis Procedure .....	101
Fail-safe (ADAS Control Unit) .....	57	<b>C1A01 POWER SUPPLY CIRCUIT 1, C1A02 POWER SUPPLY CIRCUIT 2</b> .....	<b>102</b>
DTC Inspection Priority Chart .....	57	DTC Logic .....	102
DTC Index .....	58	Diagnosis Procedure .....	102
<b>ICC SENSOR</b> .....	<b>62</b>	<b>C1A12 RADAR OFF-CENTER</b> .....	<b>103</b>
Reference Value .....	62	DTC Logic .....	103
Fail-safe (ICC Sensor) .....	63	Diagnosis Procedure .....	103
DTC Inspection Priority Chart .....	63	<b>C1A16 RADAR BLOCKED</b> .....	<b>104</b>
DTC Index .....	63	DTC Logic .....	104
<b>DRIVER ASSISTANCE BUZZER CONTROL MODULE</b> .....	<b>65</b>	Diagnosis Procedure .....	104
Reference Value .....	65	<b>C1A21 UNIT HIGH TEMP</b> .....	<b>106</b>
DTC Inspection Priority Chart .....	68	DTC Logic .....	106
DTC Index .....	68	Diagnosis Procedure .....	106
<b>WIRING DIAGRAM</b> .....	<b>70</b>	<b>C1A23 UNIT LOW TEMP</b> .....	<b>107</b>
<b>INTELLIGENT CRUISE CONTROL</b> .....	<b>70</b>	DTC Logic .....	107
Wiring Diagram .....	70	Diagnosis Procedure .....	107
<b>BASIC INSPECTION</b> .....	<b>80</b>	<b>C1A39 STEERING ANGLE SENSOR</b> .....	<b>108</b>
<b>DIAGNOSIS AND REPAIR WORK FLOW</b> .....	<b>80</b>	DTC Logic .....	108
Work Flow .....	80	Diagnosis Procedure .....	108
<b>ADDITIONAL SERVICE WHEN REPLACING ICC SENSOR</b> .....	<b>82</b>	<b>C1A50 ADAS CONTROL UNIT</b> .....	<b>109</b>
Description .....	82	DTC Logic .....	109
Work Procedure .....	82	Diagnosis Procedure .....	109
<b>ICC SENSOR ALIGNMENT</b> .....	<b>83</b>	<b>U0104 ADAS CAN 1</b> .....	<b>110</b>
Application Notice .....	83	DTC Logic .....	110
<b>TYPE 1</b> .....	<b>83</b>	Diagnosis Procedure .....	110
TYPE 1 : Description .....	83	<b>U0121 VDC CAN 2</b> .....	<b>111</b>
TYPE 1 : Work Procedure (Preparation) .....	83	DTC Logic .....	111
TYPE 1 : Work Procedure (Setting The ICC Target Board) .....	84	Diagnosis Procedure .....	111
TYPE 1 : Work Procedure (Radar Alignment) .....	86	<b>U0126 STRG SEN CAN 1</b> .....	<b>112</b>
<b>TYPE 2</b> .....	<b>87</b>	DTC Logic .....	112
TYPE 2 : Description .....	87	Diagnosis Procedure .....	112
TYPE 2 : Required Tools .....	88	<b>U0405 ADAS CAN 2</b> .....	<b>113</b>
TYPE 2 : Preparation .....	89	DTC Logic .....	113
TYPE 2 : Vehicle Set Up .....	90	Diagnosis Procedure .....	113
TYPE 2 : Setting The ICC Target Board .....	92	<b>U0415 VDC CAN 1</b> .....	<b>114</b>
TYPE 2 : ICC Sensor Adjustment .....	93	DTC Logic .....	114
<b>ACTION TEST</b> .....	<b>95</b>	Diagnosis Procedure .....	114
Description .....	95	<b>U0428 STRG SEN CAN 2</b> .....	<b>115</b>
Work Procedure (Vehicle-To-Vehicle Distance Control Mode) .....	95	DTC Logic .....	115
		Diagnosis Procedure .....	115
		<b>U1000 CAN COMM CIRCUIT</b> .....	<b>116</b>

Description .....	116	<b>CHIME DOES NOT SOUND</b> .....	125	
DTC Logic .....	116	Description .....	125	A
Diagnosis Procedure .....	116	Diagnosis Procedure .....	125	
<b>U1010 CONTROL UNIT (CAN)</b> .....	117	<b>DRIVING FORCE IS HUNTING</b> .....	127	B
Description .....	117	Description .....	127	
DTC Logic .....	117	Diagnosis Procedure .....	127	
Diagnosis Procedure .....	117	<b>FREQUENTLY CANNOT DETECT THE VEHI-</b>		C
<b>POWER SUPPLY AND GROUND CIRCUIT ...</b>	118	<b>CLE AHEAD / DETECTION ZONE IS SHORT.</b>	128	
Diagnosis Procedure .....	118	Description .....	128	D
<b>SYMPTOM DIAGNOSIS</b> .....	119	Diagnosis Procedure .....	128	
<b>INTELLIGENT CRUISE CONTROL SYSTEM</b>		<b>THE SYSTEM DOES NOT DETECT THE VE-</b>		E
<b>SYMPTOMS</b> .....	119	<b>HICLE AHEAD AT ALL</b> .....	130	
Symptom Table .....	119	Description .....	130	
<b>MAIN SWITCH DOES NOT TURN ON, MAIN</b>		Diagnosis Procedure .....	130	F
<b>SWITCH DOES NOT TURN OFF</b> .....	120	<b>NORMAL OPERATING CONDITION</b> .....	132	
Description .....	120	Description .....	132	
Diagnosis Procedure .....	120	<b>REMOVAL AND INSTALLATION</b> .....	135	G
<b>ICC SYSTEM CANNOT BE SET (MAIN</b>		<b>ICC SENSOR</b> .....	135	
<b>SWITCH TURNS ON/OFF)</b> .....	121	Exploded View .....	135	H
Description .....	121	Removal and Installation .....	135	
Diagnosis Procedure .....	121	<b>ICC STEERING SWITCH</b> .....	137	I
<b>ICC STEERING SWITCH (OTHER THAN</b>		Exploded View .....	137	
<b>MAIN SWITCH) DOES NOT FUNCTION</b> .....	123	<b>ASCD</b>		
Description .....	123	<b>SYSTEM DESCRIPTION</b> .....	138	J
Diagnosis Procedure .....	123	<b>AUTOMATIC SPEED CONTROL DEVICE</b>		
<b>ICC SYSTEM DOES NOT CANCEL WHEN A/</b>		<b>(ASCD)</b> .....	138	K
<b>T SELECTOR LEVER SETS ON "N"</b> .....	124	Information .....	138	
Description .....	124			L
Diagnosis Procedure .....	124			M
				N

## PRECAUTION

### PRECAUTIONS

#### Precaution for Supplemental Restraint System (SRS) "AIR BAG" and "SEAT BELT PRE-TENSIONER"

INFOID:000000009727802

The Supplemental Restraint System such as "AIR BAG" and "SEAT BELT PRE-TENSIONER", used along with a front seat belt, helps to reduce the risk or severity of injury to the driver and front passenger for certain types of collision. This system includes seat belt switch inputs and dual stage front air bag modules. The SRS system uses the seat belt switches to determine the front air bag deployment, and may only deploy one front air bag, depending on the severity of a collision and whether the front occupants are belted or unbelted. Information necessary to service the system safely is included in the "SRS AIR BAG" and "SEAT BELT" of this Service Manual.

**WARNING:**

Always observe the following items for preventing accidental activation.

- To avoid rendering the SRS inoperative, which could increase the risk of personal injury or death in the event of a collision that would result in air bag inflation, all maintenance must be performed by an authorized NISSAN/INFINITI dealer.
- Improper maintenance, including incorrect removal and installation of the SRS, can lead to personal injury caused by unintentional activation of the system. For removal of Spiral Cable and Air Bag Module, see "SRS AIR BAG".
- Never use electrical test equipment on any circuit related to the SRS unless instructed to in this Service Manual. SRS wiring harnesses can be identified by yellow and/or orange harnesses or harness connectors.

#### PRECAUTIONS WHEN USING POWER TOOLS (AIR OR ELECTRIC) AND HAMMERS

**WARNING:**

Always observe the following items for preventing accidental activation.

- When working near the Air Bag Diagnosis Sensor Unit or other Air Bag System sensors with the ignition ON or engine running, never use air or electric power tools or strike near the sensor(s) with a hammer. Heavy vibration could activate the sensor(s) and deploy the air bag(s), possibly causing serious injury.
- When using air or electric power tools or hammers, always switch the ignition OFF, disconnect the battery, and wait at least 3 minutes before performing any service.

#### Precautions For Harness Repair

INFOID:000000009644190

ITS communication uses a twisted pair line. Be careful when repairing it.

- Solder the repaired area and wrap tape around the soldered area.

**NOTE:**

A fray of twisted lines must be within 110 mm (4.33 in).

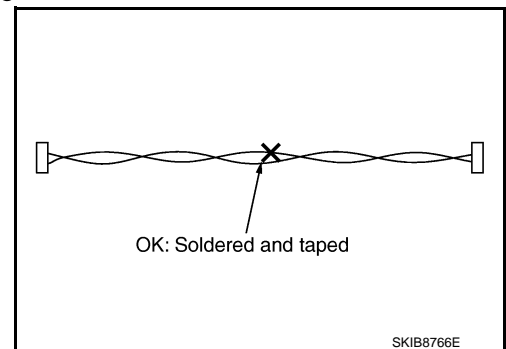

# PRECAUTIONS

[ICC]

## < PRECAUTION >

- Bypass connection is never allowed at the repaired area.

### NOTE:

Bypass connection may cause ITS communication error. The spliced wire becomes separated and the characteristics of twisted line are lost.

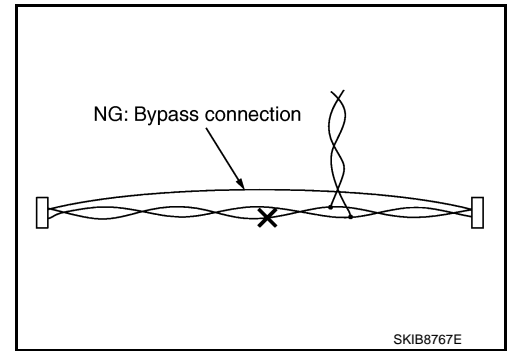

## ICC System Service

INFOID:000000009644191

### CAUTION:

- Turn the MAIN switch OFF in conditions similar to driving, such as free rollers or a chassis dynamometer.
- Never use the ICC sensor removed from vehicle. Never disassemble or remodel.
- Erase DTC when replacing parts of ICC system, then check the operation of ICC system after radar alignment if necessary.

A  
B  
C  
D  
E  
F  
G  
H  
I  
J  
K  
L  
M  
N  
P

CCS

# PREPARATION

< PREPARATION >

[ICC]

## PREPARATION

### PREPARATION

#### Special Service Tools

INFOID:000000009644192

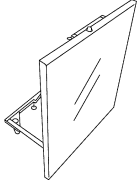
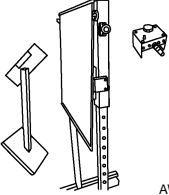
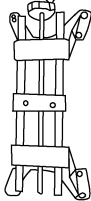
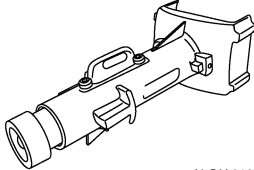
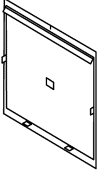
Tool number (Kent-Moore No.) Tool name	Description
KV99112700 (—) ICC target board	 <p style="text-align: right;">JSOIA1012ZZ</p> Uses for radar alignment
— (1-20-2722-1-IF) ICC alignment kit*	 <p style="text-align: right;">AWOIA0016ZZ</p> Uses for radar alignment
— (1-20-2722-1-IF) Wheel adaptor*	 <p style="text-align: right;">AWOIA0017ZZ</p> Uses for radar alignment
— (J-51093) ICC sensor cone alignment tool*	 <p style="text-align: right;">ALOIA0197ZZ</p> Uses for radar alignment
— (J-50808) ICC alignment kit attachment board*	 <p style="text-align: right;">JSOIA1065ZZ</p> Uses for radar alignment

**NOTE:**

For radar alignment, KV99112700 or a set of Kent-Moore No. SST are to be used.

\*: This service manual does not apply when using special service tool 1-20-2722-1-IF, J-51093, and J-50808. For the radar alignment procedure with these tools, refer to the instructions included with the tool.

## SYSTEM DESCRIPTION

### COMPONENT PARTS

#### Component Parts Location

INFOID:000000009644193

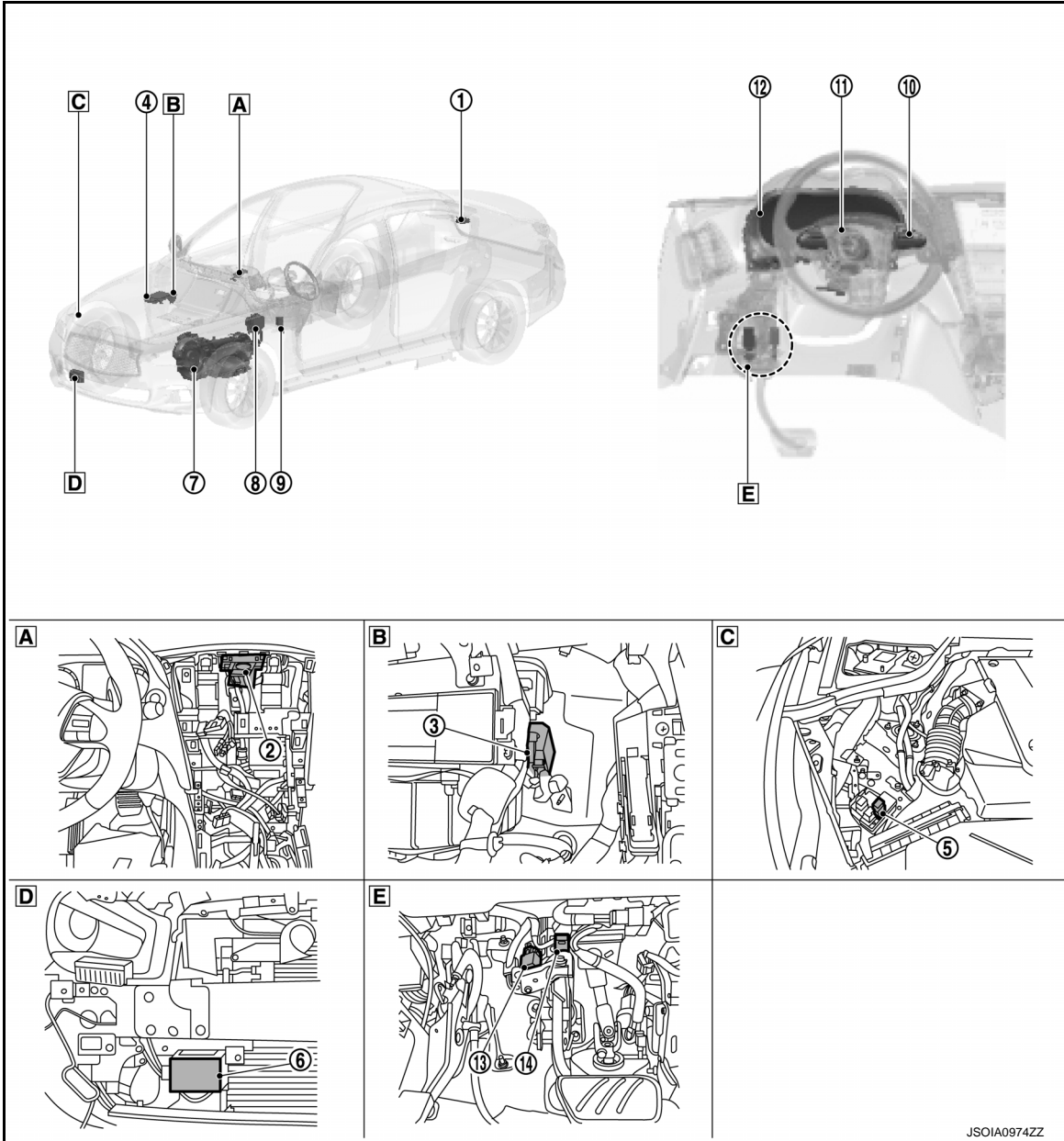

**A** Instrument panel (Center)

**B** Instrument lower panel (RH)

**C** Engine room (RH)

**D** Front bumper (RH)

**E** Upper side of brake pedal

A  
B  
C  
D  
E  
F  
G  
H  
I  
J  
K  
L  
M  
N  
P

CCS

# COMPONENT PARTS

< SYSTEM DESCRIPTION >

[ICC]

×: Applicable

No.	Component	Function		Description
		Vehicle-to-vehicle distance control mode	Conventional (fixed speed) cruise control mode	
①	ADAS control unit	×	×	Refer to <a href="#">CCS-9, "ADAS Control Unit"</a> Refer to <a href="#">DAS-14, "Component Parts Location"</a> for detailed installation location
②	Driver assistance buzzer	×	×	Refer to <a href="#">CCS-11, "Driver Assistance Buzzer"</a>
③	Driver assistance buzzer control module	×	×	Refer to <a href="#">CCS-11, "Driver Assistance Buzzer Control Module"</a>
④	ECM	×	×	<ul style="list-style-type: none"> <li>ECM transmits the accelerator pedal position signal, ICC brake switch signal, stop lamp switch signal, ICC steering switch etc. to ADAS control unit via CAN communication</li> <li>ECM controls the electric throttle control actuator based on the engine torque demand received from the ADAS control unit via CAN communication</li> </ul>
⑤	ICC brake hold relay	×		Refer to <a href="#">CCS-10, "ICC Brake Hold Relay"</a>
⑥	ICC sensor	×	×	Refer to <a href="#">CCS-9, "ICC Sensor"</a>
⑦	TCM	×	×	TCM transmits the signal related to A/T control to ADAS control unit via CAN communication
⑧	ABS actuator and electric unit (control unit)	×	×	<ul style="list-style-type: none"> <li>ABS actuator and electric unit (control unit) transmits the vehicle speed signal (wheel speed), stop lamp switch signal and VDC/TCS/ABS system operation condition to ADAS control unit via CAN communication</li> <li>ABS actuator and electric unit (control unit) controls the brake, based on a brake fluid pressure control signal received from the ADAS control unit via chassis control module</li> </ul>
⑨	Chassis control module	×	×	Chassis control module transmits the drive mode signal to ADAS control unit via CAN communication
⑩	ICC steering switch	×	×	<ul style="list-style-type: none"> <li>Description: Refer to <a href="#">CCS-10, "ICC Steering Switch"</a></li> <li>Switch name and function: <a href="#">CCS-20, "VEHICLE-TO-VEHICLE DISTANCE CONTROL MODE FUNCTION : Switch Name and Function"</a> (Vehicle to vehicle distance control mode)</li> <li>Switch name and function: <a href="#">CCS-24, "CONVENTIONAL (FIXED SPEED) CRUISE CONTROL MODE FUNCTION : Switch Name and Function"</a> (Conventional cruise control mode)</li> </ul>
⑪	Steering angle sensor	×		Measures the rotation amount, rotation speed, and rotation direction of steering wheel, and then transmits them to ADAS control unit via CAN communication



# COMPONENT PARTS

< SYSTEM DESCRIPTION >

[ICC]

No.	Component	Function		Description
		Vehicle-to-vehicle distance control mode	Conventional (fixed speed) cruise control mode	
⑫	Combination meter	×	×	Performs the following operations using the signals received from the ADAS control unit via the CAN communication <ul style="list-style-type: none"> <li>• Description: Refer to <a href="#">CCS-10, "Combination Meter"</a></li> <li>• System display and warning: <a href="#">CCS-20, "VEHICLE-TO-VEHICLE DISTANCE CONTROL MODE FUNCTION : Menu Displayed by Pressing Each Switch"</a> (Vehicle to vehicle distance control mode)</li> <li>• System display and warning: <a href="#">CCS-24, "CONVENTIONAL (FIXED SPEED) CRUISE CONTROL MODE FUNCTION : Menu Displayed by Pressing Each Switch"</a> (Conventional cruise control mode)</li> </ul>
⑬	Stop lamp switch	×	×	Refer to <a href="#">CCS-10, "Brake Pedal Position Switch / Stop Lamp Switch"</a>
⑭	Brake pedal position switch	×	×	

A  
B  
C  
D  
E  
F  
G  
H  
I  
J  
K  
L  
M  
N  
P

## ADAS Control Unit

INFOID:000000009716265

- ADAS control unit is installed at trunk side of the parcel shelf.
- Communicates with each control unit via CAN communication/ITS communication/Chassis communication.
- ADAS control unit included gateway function, and necessary for system control signals are transmitted to each control unit between CAN communication and ITS communication by the ADAS control unit.
- ADAS control unit controls the each system, based on ITS communication signal, CAN communication signal, and chassis communication signal from each control unit.

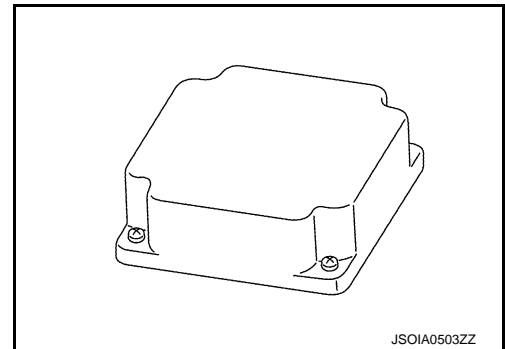

## ICC Sensor

INFOID:000000009644195

- ICC sensor is installed on the back of the front bumper and detects a vehicle ahead by using millimeter waves.
- ICC sensor detects radar reflected from a vehicle ahead by irradiating radar forward and calculates a distance from the vehicle ahead and relative speed, based on the detected signal.
- ICC sensor transmits the presence/absence of vehicle ahead and the distance from the vehicle to ADAS control unit via ITS communication.

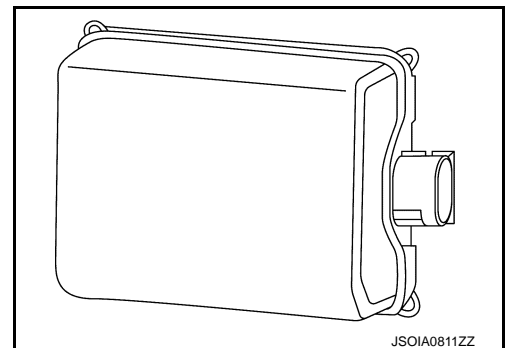

CCS

# COMPONENT PARTS

< SYSTEM DESCRIPTION >

[ICC]

## ICC Steering Switch

INFOID:000000009716266

- ICC steering switch is installed to the steering wheel and allows the driver to operate the ICC system by using this switch.
- ICC steering switch allows the ON/OFF of the Intelligent Cruise Control and the settings of a vehicle speed and distance between vehicles.
- ICC steering switch signal is transmitted to ECM. ECM transmits the signal to the ADAS control unit via CAN communication.

## Brake Pedal Position Switch / Stop Lamp Switch

INFOID:000000009644197

- Brake pedal position switch is installed at the upper part of the brake pedal and detects a brake operation performed by the driver.

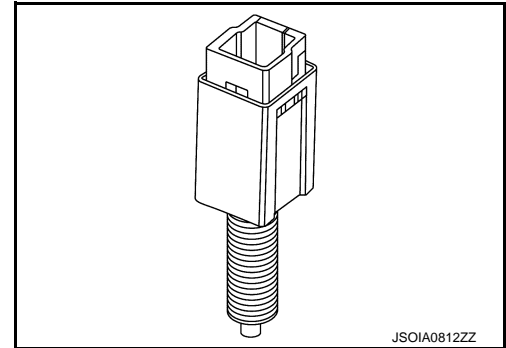

- Brake pedal position switch is turned OFF when depressing the brake pedal.
- Brake pedal position switch signal is input to ECM. Brake pedal position switch signal is transmitted from ECM to ADAS control unit via CAN communication.
- Stop lamp switch is installed at the upper part of the brake pedal and detects a brake operation performed by the driver.
- Stop lamp switch is turned ON, when depressing the brake pedal.
- Stop lamp switch signal is input to ECM and ABS actuator and electric unit (control unit). Stop lamp switch signals are transmitted from ECM and ABS actuator and electric unit (control unit) to ADAS control unit via CAN communication.

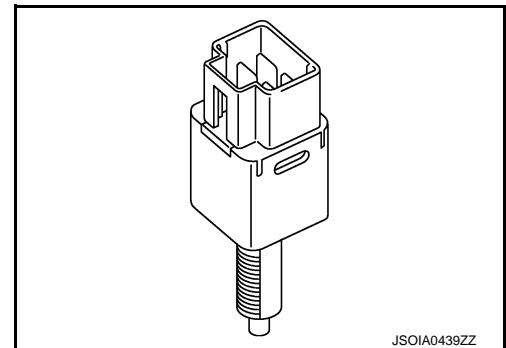

## ICC Brake Hold Relay

INFOID:000000009644198

- ICC brake hold relay is installed in the engine room (right side).
- When the brake is activated by the system, the ICC brake hold relay turns ON the stop lamp by bypassing the circuit of the stop lamp, according to a signal transmitted from the ADAS control unit.

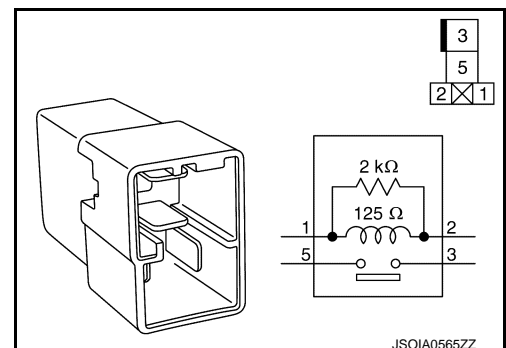

## Combination Meter

INFOID:000000009716267

- Receives meter display signal from ADAS control unit via CAN communication.
- Displays the system status according to a signal received from the ADAS control unit.

# COMPONENT PARTS

< SYSTEM DESCRIPTION >

[ICC]

## Driver Assistance Buzzer Control Module

INFOID:000000009716268

- Driver assistance buzzer control module is installed at the behind of glove box.
- When driver assistance buzzer signal is received from the ADAS control unit, the driver assistance buzzer control module transmits the warning buzzer signal to driver assistance buzzer.

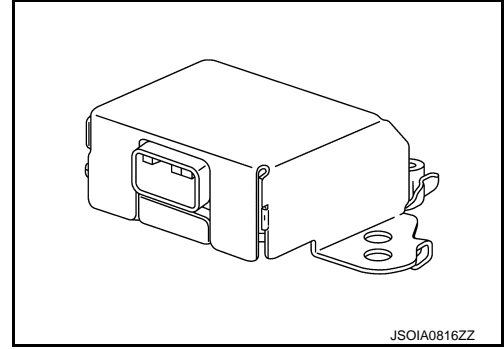

## Driver Assistance Buzzer

INFOID:000000009716269

- Driver assistance buzzer is installed at the behind the display control unit.
- When a warning buzzer signal is received from the driver assistance buzzer control module, the driver assistance buzzer sounds a buzzer.

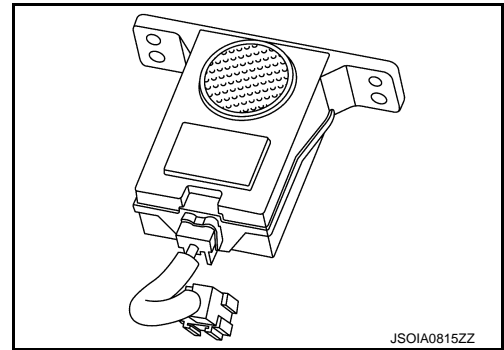

A  
B  
C  
D  
E  
F  
G  
H  
I  
J  
K  
L  
M  
N  
P

CCS

SYSTEM

System Description

INFOID:000000009644202

SYSTEM DIAGRAM

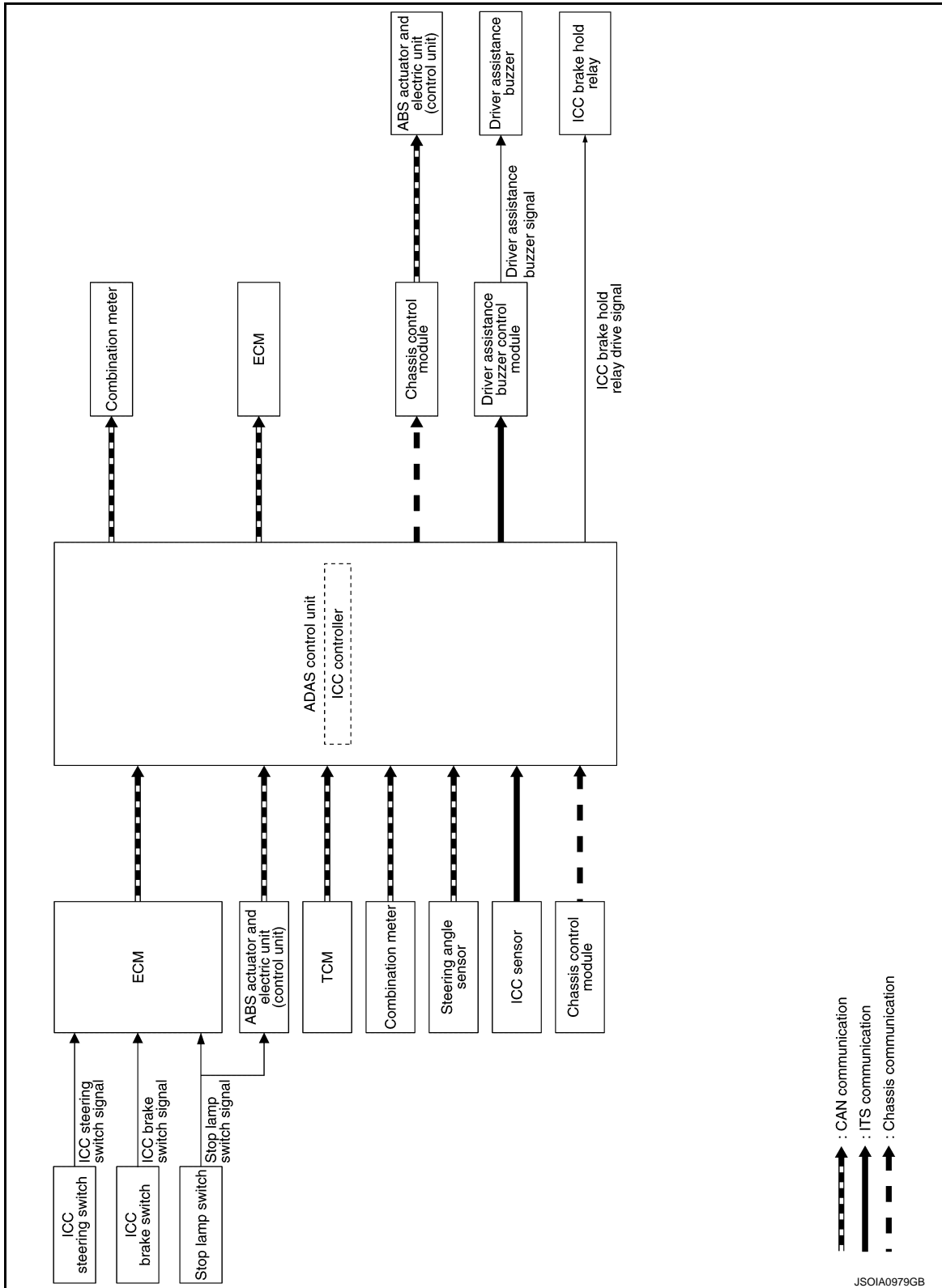

ADAS CONTROL UNIT INPUT/OUTPUT SIGNAL ITEM

Input Signal Item

# SYSTEM

< SYSTEM DESCRIPTION >

[ICC]

Transmit unit	Signal name		Description	
ECM	CAN communication	Closed throttle position signal	Receives idle position state (ON/OFF)	
		Accelerator pedal position signal	Receives accelerator pedal position (angle)	
		ICC prohibition signal	Receives an operable/inoperable state of the ICC system	
		Engine speed signal	Receives engine speed	
		ICC steering switch signal	MAIN switch signal	Receives the operational state of the ICC steering switch
			SET/COAST switch signal	
			CANCEL switch signal	
			RESUME/ACCELERATE switch signal	
			DISTANCE switch signal	
		Stop lamp switch signal	Receives an operational state of the brake pedal	
Brake pedal position switch signal	Receives an operational state of the brake pedal			
TCM	CAN communication	Input speed signal	Receives the number of revolutions of input shaft	
		Current gear position signal	Receives a current gear position	
		Shift position signal	Receives a selector lever position	
		Output shaft revolution signal	Receives the number of revolutions of output shaft	
ABS actuator and electric unit (control unit)	CAN communication	ABS malfunction signal	Receives a malfunction state of ABS	
		ABS operation signal	Receives an operational state of ABS	
		ABS warning lamp signal	Receives an ON/OFF state of ABS warning lamp	
		TCS malfunction signal	Receives a malfunction state of TCS	
		TCS operation signal	Receives an operational state of TCS	
		VDC OFF switch signal	Receives an ON/OFF state of VDC	
		VDC malfunction signal	Receives a malfunction state of VDC	
		VDC operation signal	Receives an operational state of VDC	
		Vehicle speed signal (ABS)	Receives wheel speeds of four wheels	
		Stop lamp switch signal	Receives an operational state of the brake pedal	
Yaw rate signal	Receives yaw rate acting on the vehicle			
Combination meter	CAN communication	Parking brake switch signal	Receives an operational state of the parking brake	
Steering angle sensor	CAN communication	Steering angle sensor malfunction signal	Receives a malfunction state of steering angle sensor	
		Steering angle sensor signal	Receives the number of revolutions, turning direction of the steering wheel	
		Steering angle speed signal	Receives the turning angle speed of the steering wheel	
Chassis control module	CAN communication	Drive mode signal      Snow mode	Receives an operational state of the snow mode	
ICC sensor	ITS communication	ICC sensor signal	Receives detection results, such as the presence or absence of a leading vehicle and distance from the vehicle	

A  
B  
C  
D  
E  
F  
G  
H  
I  
J  
K  
L  
M  
N  
P

CCS

Output Signal Item

# SYSTEM

< SYSTEM DESCRIPTION >

[ICC]

Reception unit	Signal name		Description
ECM	CAN communication	ICC operation signal	Transmits an ICC operation signal necessary for intelligent cruise control
ABS actuator and electric unit (control unit)	CAN communication	Brake fluid pressure control signal	Transmits a brake fluid pressure control signal to activates the brake via chassis control module
Combination meter	CAN communication	Meter display signal	Vehicle ahead detection indicator signal
			Set vehicle speed indicator signal
			Set distance indicator signal
			SET switch indicator signal
			MAIN switch indicator signal
		ICC malfunction signal	Transmits an ICC malfunction signal to turn ON the ICC system malfunction
ICC sensor	ITS communication	Vehicle speed signal	Transmits a vehicle speed calculated by the ADAS control unit
Driver assistance buzzer control module	ITS communication	Warning buzzer signal	Transmits a warning buzzer signal to turn ON the buzzer
ICC brake hold relay	ICC brake hold relay drive signal		Activates the brake hold relay and turns ON the stop lamp

## DESCRIPTION

### Intelligent Cruise Control

The Intelligent Cruise Control (ICC) system maintains a selected distance from the vehicle ahead within set speeds.

The driver can select the set speeds.

The vehicle travels at a set speed when the road ahead is clear.

The ICC system can be set to one of two cruise control modes:

#### **CAUTION:**

**Never set the cruise speed exceeding the posted speed limit.**

#### Vehicle-to-vehicle Distance Control Mode

For maintaining a selected distance between own vehicle and the vehicle in front of own vehicle up to the preset speed. Refer to [CCS-16, "VEHICLE-TO-VEHICLE DISTANCE CONTROL MODE FUNCTION : System Description"](#).

#### Conventional (Fixed Speed) Cruise Control Mode

For cruising at a preset speed. Refer to [CCS-18, "CONVENTIONAL \(FIXED SPEED\) CRUISE CONTROL MODE FUNCTION : System Description"](#).

#### **NOTE:**

In the Conventional (Fixed Speed) Cruise Control Mode, a warning chime will not sound to warn driver if own vehicle are too close to the vehicle ahead.

#### **WARNING:**

**Always drive carefully and attentively when using either cruise control mode. To avoid serious injury or death, do not rely on the system to prevent accidents or to control the vehicle's speed in emergency situations. Do not use cruise control except in appropriate road and traffic conditions.**

#### Distance Control Assist (DCA) System

DCA share the systems and components with ICC system. Refer to [DAS-170, "DCA : System Description"](#).

#### Predictive Forward Collision Warning (PFCW) System

PFCW share the systems and components with ICC system. Refer to [DAS-174, "PFCW : System Description"](#).

< SYSTEM DESCRIPTION >

Forward Emergency Brake (FEB) System

FEB system share the systems and components with ICC system. Refer to [BRC-187. "System Description"](#).

Circuit Diagram

INFOID:000000009644203

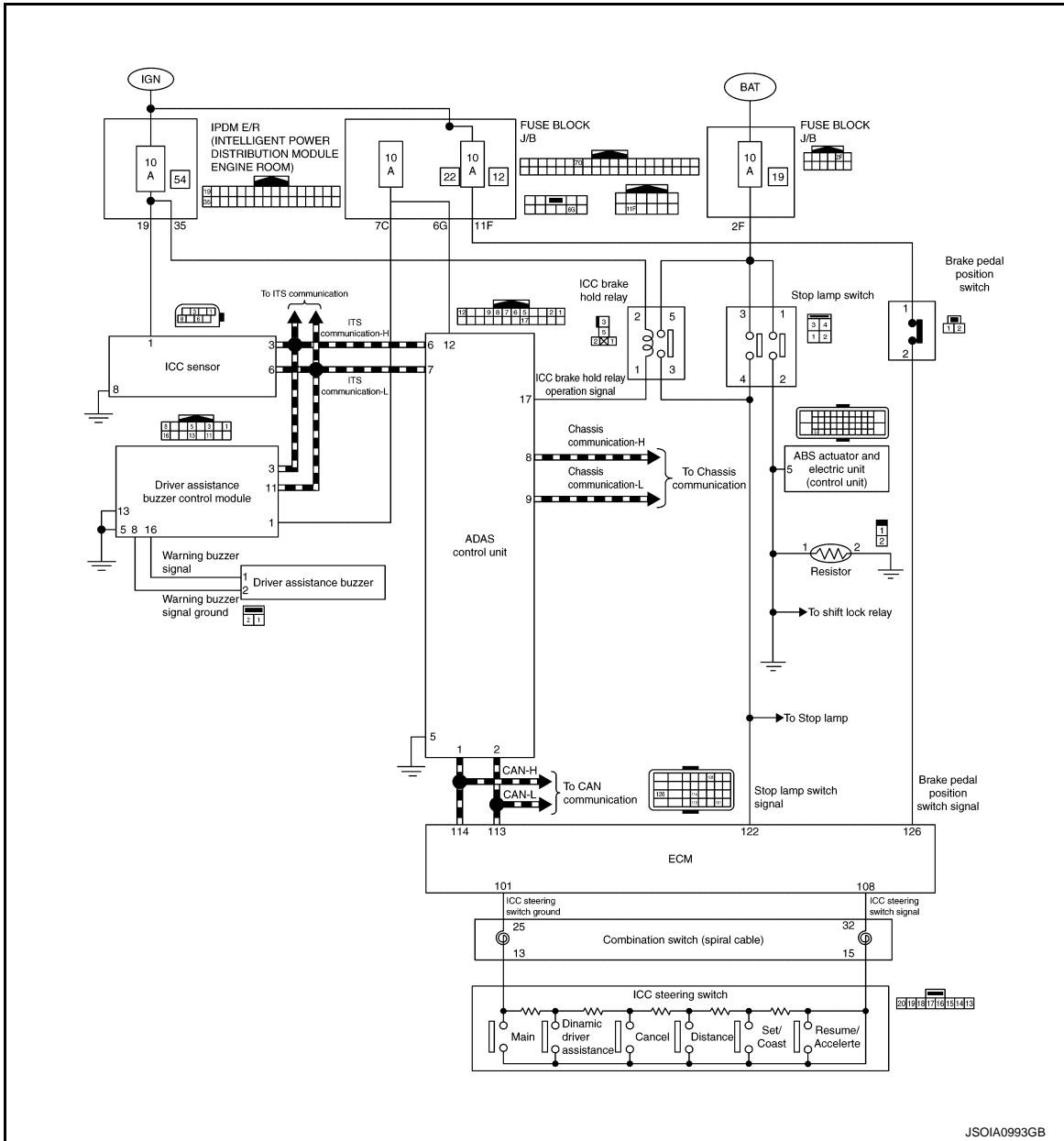

Fail-safe (ADAS Control Unit)

INFOID:000000009727812

If a malfunction occurs in each system, ADAS control unit cancels each control, sounds a beep, and turns ON the warning or indicator lamp.

System	Buzzer	Warning lamp/Warning display	Description
Vehicle-to-vehicle distance control mode	High-pitched tone	ICC system warning	Cancel
Conventional (fixed speed) cruise control mode	High-pitched tone	ICC system warning	Cancel

# SYSTEM

< SYSTEM DESCRIPTION >

[ICC]

System	Buzzer	Warning lamp/Warning display	Description
Forward Emergency Braking (FEB)	High-pitched tone	<ul style="list-style-type: none"><li>FEB warning lamp</li><li>Warning systems indicator (Forward position: Yellow)</li></ul>	Cancel
Predictive Forward Collision Warning (PFCW)	High-pitched tone	Warning systems indicator (Forward position: Yellow)	Cancel
Distance Control Assist (DCA)	High-pitched tone	Warning systems indicator (Forward position: Yellow)	Cancel
Blind Spot Warning (BSW)	—	Warning systems indicator (Blind spot position: Yellow)	Cancel
Back-up Collision Intervention (BCI)	High-pitched tone	BCI system warning	Cancel

## Fail-safe (ICC Sensor)

INFOID:000000009644205

If a malfunction occurs in the ICC sensor, ADAS control unit cancels control, sounds a beep, and turns ON the ICC system warning in the information display.

## VEHICLE-TO-VEHICLE DISTANCE CONTROL MODE FUNCTION

### VEHICLE-TO-VEHICLE DISTANCE CONTROL MODE FUNCTION : System Description

INFOID:000000009644206

#### FUNCTION DESCRIPTION

In the vehicle-to-vehicle distance control mode, the Intelligent Cruise Control (ICC) system automatically maintains a selected distance from the vehicle traveling in front of own vehicle according to that vehicle's speed (up to the set speed), or at the set speed when the road ahead is clear.

With ICC system, the driver can maintain the same speed as other vehicles without the constant need to adjust the set speed as driver would with a normal cruise control system.

The following items are controlled in the vehicle-to-vehicle distance control mode

- When there are no vehicles traveling ahead, the vehicle-to-vehicle distance control mode maintains the speed set by the driver. The selectable speed ranges are as follows:
  - Between approximately 32 and 144 km/h (20 and 90 MPH).
- When there is a vehicle traveling ahead, the vehicle-to-vehicle distance control mode adjusts the speed to maintain the distance, selected by driver, from a vehicle ahead. The adjusting speed range is up to the set speed.
- When the vehicle traveling ahead has moved out from its lane of travel, the vehicle-to-vehicle distance control mode accelerates and maintains vehicle speed up to the set speed.

#### CAUTION:

- **If the vehicle ahead comes to stop, the vehicle decelerates to a standstill within the limitations of the system. The system will cancel once it judges that the vehicle has come to a standstill and sound a warning chime.**
- **To prevent the vehicle from moving, the driver must depress the brake pedal.**

#### NOTE:

When the accelerator pedal is depressed, the brake operation and the warning are not performed by the ICC system.

#### OPERATION DESCRIPTION

Quickly push (less than 1.5 seconds) and release the MAIN switch ON.

The MAIN switch indicator, set distance indicator, own vehicle indicator, and set vehicle speed indicator come on and ICC system is set to a standby state.

ADAS control unit performs the control as per the following:



# SYSTEM

## < SYSTEM DESCRIPTION >

[ICC]

Constant speed	Comparing the set vehicle speed with the current vehicle speed, transmit the command to ECM via CAN communication to reach the set vehicle speed, and controls the electric throttle control actuator.
Deceleration	When a vehicle ahead (slower than driver set vehicle speed) appears or when a vehicle ahead slows down, the system controls the electric throttle control actuator into the close direction and decelerates the vehicle. If greater deceleration is necessary, the system transmits the brake fluid pressure control signal to the ABS actuator and electric unit (control unit) via chassis control module and operates the brake.
Following	The system controls electric throttle control actuator and the brake fluid pressure to keep the proper distance between the vehicles according to the vehicle speed change of the vehicle ahead.
Acceleration	When a vehicle ahead is not detected because of it changes lanes or own vehicle changes lanes during the following driving, the system controls the electric throttle control actuator in the open direction and accelerates the vehicle to the set vehicle speed slowly.

### Set Condition

Under a standby state, pushing down the SET/COAST switch will start system control.

- When vehicle speed is between approximately 32 km/h and 144 km/h (20 MPH and 90 MPH).
- When vehicle speed is below approximately 32 km/h (20 MPH) if the vehicle ahead is detected. The set vehicle speed becomes 32 km/h (20 MPH).

If the system is canceled by conditions 1–10 below, the system will resume control at the last set cruising speed by pushing up the RESUME/ACCELERATE switch.

### NOTE:

- When the SET/COAST switch is pushed under the following conditions, the system cannot be set and the set vehicle speed indicator will blink for approximately 2 seconds.

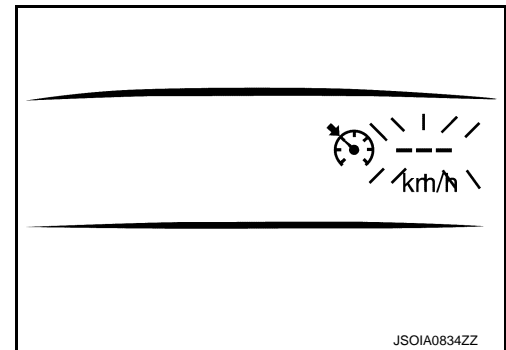

- When traveling below 32 km/h (20 MPH) and the vehicle ahead is not detected.
- When the selector lever is not in the “D” position or manual mode.
- When the parking brakes are applied.
- When the brakes are operated by the driver.

- When the SET/COAST switch is pushed under the following conditions, the system cannot be set. A warning chime will sound and the set speed indicator will blink.

- When the drive mode select switch is in SNOW position. (To use the ICC system, turn OFF the snow mode, push the MAIN switch to turn OFF the ICC system and reset the ICC system by pushing the MAIN switch again.)

- When the VDC is OFF. (To use the ICC system, turn ON the VDC system, push the MAIN switch to turn OFF the ICC system and reset the ICC system by pushing the MAIN switch again.)

- When ABS or VDC (including the TCS) operates.

- When the wheel is slipping. (To use the ICC system, make sure the wheels are no longer spinning, push the MAIN switch to turn OFF the ICC system and reset the ICC system by pushing the MAIN switch again.)

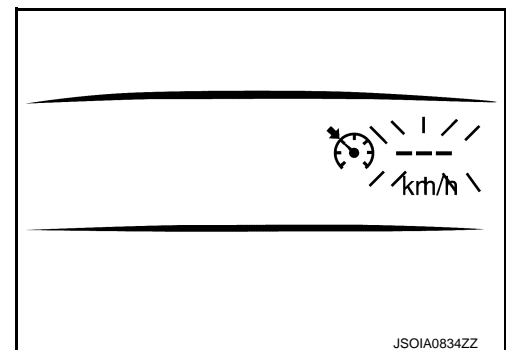

### Cancel Conditions

1. When CANCEL switch is pressed.
2. When brake pedal is depressed.
3. When the vehicle ahead is not detected below the speed of 24 km/h (15 MPH).
4. When the selector lever is not in the “D” position or manual mode.
5. When the parking brakes are applied.
6. When the system judges the vehicle is at standstill.
7. When the drive mode select switch is in SNOW position.
8. When ABS or VDC (including the TCS) operates.

< SYSTEM DESCRIPTION >

- 9. When a wheel slips.
- 10. When the VDC is turned OFF.
- 11. When the MAIN switch is turned OFF.
- 12. When the system malfunction occurs.

CONVENTIONAL (FIXED SPEED) CRUISE CONTROL MODE FUNCTION

CONVENTIONAL (FIXED SPEED) CRUISE CONTROL MODE FUNCTION : System Description

INFOID:000000009644207

FUNCTION DESCRIPTION

This mode allows driving at a speed between 40 to 144 km/h (25 to 90 MPH) without keeping foot on the accelerator pedal.

**NOTE:**

In the conventional (fixed speed) cruise control mode, a warning chime does not sound to warn driver if own vehicle are too close to the vehicle ahead, as neither the presence of the vehicle ahead nor the vehicle-to-vehicle distance is detected.

OPERATION DESCRIPTION

To turn ON the conventional (fixed speed) cruise control mode, push and hold the MAIN switch for longer than approximately 1.5 seconds when ICC system is OFF.

When pushing the MAIN switch ON, the ICC system display and the MAIN switch indicator are displayed on the information display.

After hold the MAIN switch ON for longer than approximately 1.5 seconds, the ICC system display goes out. The MAIN switch indicator stays lit and brings the system to standby state.

**NOTE:**

- To turn on the vehicle-to-vehicle distance control mode again, turn OFF the system and quickly push (less than 1.5 seconds) the MAIN switch.
- When the DCA system is ON, the conventional (fixed speed) cruise control mode cannot be turned on even though the MAIN switch is pushed and held.
- To turn ON the conventional (fixed speed) cruise control mode, turn OFF the DCA system. Refer to [DAS-170, "DCA : System Description"](#).

ADAS control unit performs the control as per the following:

Constant speed	Comparing the set vehicle speed with the current vehicle speed, transmits the command to ECM via CAN communication to reach the set vehicle speed, and controls electronic throttle control actuator.
----------------	---

Set Condition

When the system is under a standby state and the vehicle speed is between approximately 40 km/h (25 MPH) and 144 km/h (90 MPH), pushing the SET/COAST switch will start system control. If the system is canceled by conditions 1–7 below, the system will resume control at the last set cruising speed by pushing the RESUME/ACCELERATE switch.

Cancel conditions

- 1. When CANCEL switch is pressed.
- 2. When brake pedal depressed.
- 3. When the vehicle slows down more than 13 km/h (8 MPH) below the set speed.
- 4. When the selector lever is not in the "D" position or manual mode.
- 5. When the parking brakes are applied.
- 6. When VDC (including the TCS) operates.
- 7. When a wheel slips.
- 8. When the MAIN switch is turned OFF.
- 9. When the system malfunction occurs.

WARNING/INDICATOR/CHIME LIST

WARNING/INDICATOR/CHIME LIST : Warning/Indicator (On Information Display)

INFOID:000000009644209

# SYSTEM

< SYSTEM DESCRIPTION >

[ICC]

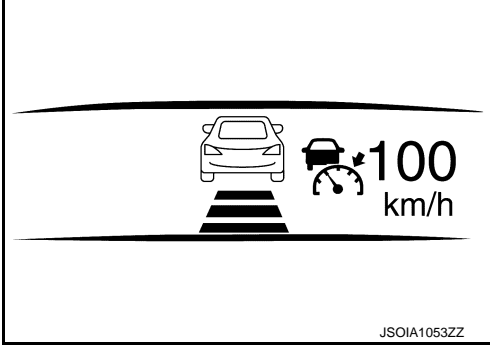
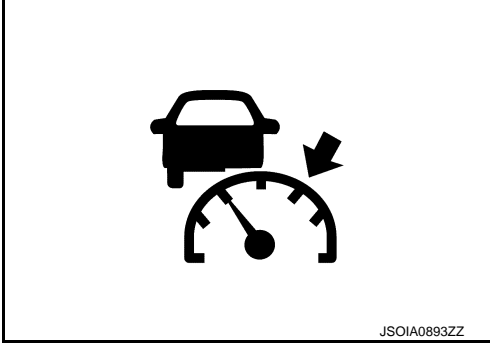
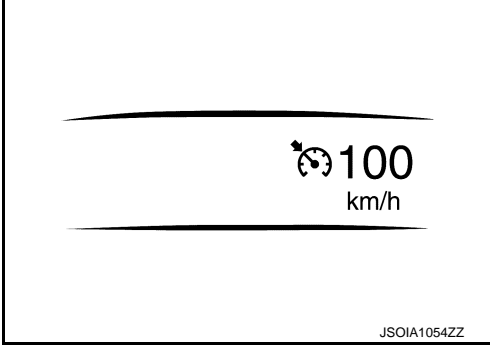
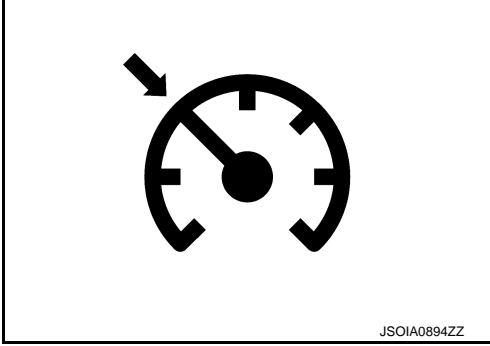
Name	Design	Function
ICC system display (Vehicle-to-vehicle distance control mode)	 <p style="text-align: right; font-size: small;">JSOIA1053ZZ</p>	<p style="color: green; font-size: small;">CCS-20. "VEHICLE-TO-VEHICLE DISTANCE CONTROL MODE FUNCTION : Menu Displayed by Pressing Each Switch"</p>
ICC system warning (Vehicle-to-vehicle distance control mode)	 <p style="text-align: right; font-size: small;">JSOIA0893ZZ</p>	
ICC system display (conventional (fixed speed) cruise control mode)	 <p style="text-align: right; font-size: small;">JSOIA1054ZZ</p>	<p style="color: green; font-size: small;">CCS-24. "CONVENTIONAL (FIXED SPEED) CRUISE CONTROL MODE FUNCTION : Menu Displayed by Pressing Each Switch"</p>
ICC system warning (conventional (fixed speed) cruise control mode)	 <p style="text-align: right; font-size: small;">JSOIA0894ZZ</p>	

A  
B  
C  
D  
E  
F  
G  
H  
I  
J  
K  
L  
M  
N  
P

CCS

OPERATION

VEHICLE-TO-VEHICLE DISTANCE CONTROL MODE FUNCTION

VEHICLE-TO-VEHICLE DISTANCE CONTROL MODE FUNCTION : Switch Name and Function

INFOID:000000009644210

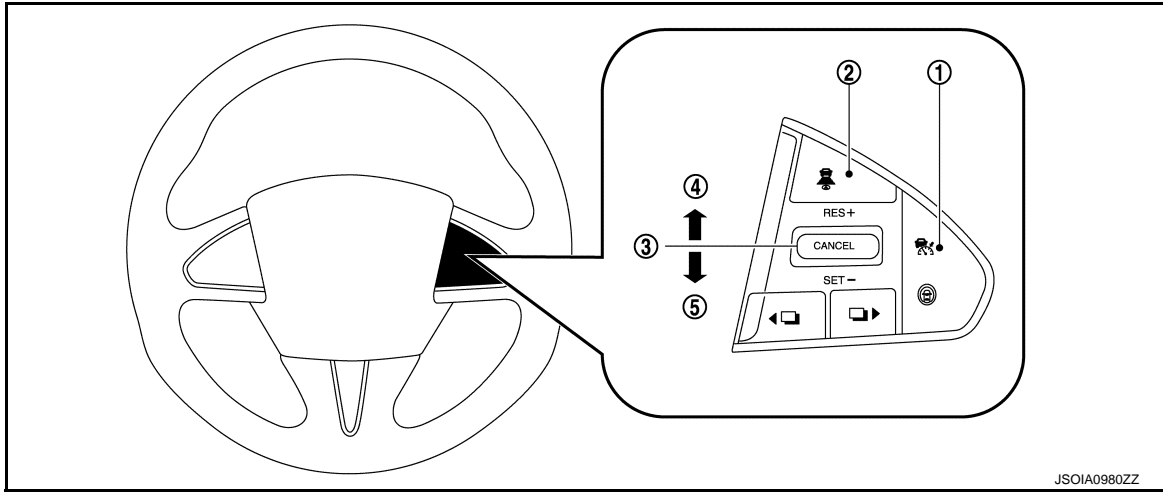

JSOIA0980ZZ

No.	Switch name	Description
①	MAIN switch	Master switch to activate the system (Press for less than 1.5 seconds)
②	DISTANCE switch	Changes the following distance from: Long, Middle, Short
③	CANCEL switch	Deactivates the system without erasing the set speed
④	RESUME/ACCELERATE switch	Resumes set speed or increases speed incrementally <ul style="list-style-type: none"> <li>• Push and hold the switch to increase the set speed by 5 km/h (5 MPH)</li> <li>• Push then quickly release the switch to increase the set speed by 1 km/h (1 MPH)</li> </ul>
⑤	SET/COAST switch	Sets desired cruise speed or reduces speed incrementally <ul style="list-style-type: none"> <li>• Push and hold the switch to decrease the set speed by 5 km/h (5 MPH)</li> <li>• Push then quickly release the switch to decrease the set speed by 1 km/h (1 MPH)</li> </ul> <b>NOTE:</b> The minimum set speed is 32 km/h (20 MPH)

VEHICLE-TO-VEHICLE DISTANCE CONTROL MODE FUNCTION : Menu Displayed by Pressing Each Switch

INFOID:000000009644211

ICC SYSTEM DISPLAY (ON THE INFORMATION DISPLAY)

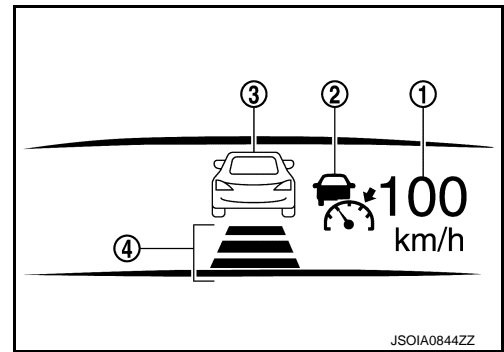

JSOIA0844ZZ

No.	Switch name	Description
①	Set vehicle speed indicator	<ul style="list-style-type: none"> <li>• Indicates the set vehicle speed</li> <li>• Indicates 32 km/h (20 MPH) when setting less than 32 km/h (20 MPH)</li> </ul>

# OPERATION

## < SYSTEM DESCRIPTION >





[ICC]

No.	Switch name	Description
②	ICC system warning lamp (yellow)	Indicates that a malfunction occurs in the ICC system
	MAIN switch indicator (white)	Indicates that the MAIN switch is ON (ICC system ON)
	Set switch indicator (green)	Indicates that the set vehicle to vehicle distance control mode is controlled
③	Vehicle ahead detection indicator	Indicates whether it detects a vehicle ahead
④	Set distance indicator	Indicates the selected distance between vehicles set with the DISTANCE switch

### SYSTEM CONTROL CONDITION DISPLAY

Quickly push (less than 1.5 seconds) and release the MAIN switch ON.

The MAIN switch indicator (cruise indicator), set distance indicator, own vehicle indicator, and set vehicle speed indicator come on and ICC system is set to a standby state.

Condition		Display on ICC system display
Standby mode		 <p style="text-align: right; font-size: small;">JSOIA0845ZZ</p>
Control mode	Without a vehicle ahead	Set vehicle distance (Long)  <p style="text-align: right; font-size: small;">JSOIA0846ZZ</p>
		Set vehicle distance (Middle)  <p style="text-align: right; font-size: small;">JSOIA0847ZZ</p>
		Set vehicle distance (Short)  <p style="text-align: right; font-size: small;">JSOIA0848ZZ</p>
		When the vehicle speed exceeds the set speed  <p style="text-align: right; font-size: small;">JSOIA0849ZZ</p>





A  
B  
C  
D  
E  
F  
G  
H  
I  
J  
K  
L  
M  
N  
P

CCS

# OPERATION

< SYSTEM DESCRIPTION >

[ICC]

		Condition	Display on ICC system display
Control mode	With a vehicle ahead	Set vehicle distance (Long)	 <small>JSOIA0850ZZ</small>
		Set vehicle distance (Middle)	 <small>JSOIA0851ZZ</small>
		Set vehicle distance (Short)	 <small>JSOIA0852ZZ</small>
		When the vehicle speed exceeds the set speed	 <small>JSOIA0853ZZ</small>

**NOTE:**

The display of the DCA system is given priority when the DCA system is ON in a standby mode. (The set vehicle speed indicator, and set distance indicator, are not displayed).

**APPROACH WARNING DISPLAY**

If own vehicle comes closer to a vehicle ahead due to rapid deceleration of that vehicle or if another vehicle cuts in, the system warns the driver with the chime and ICC system display. Decelerate by depressing the brake pedal to maintain a safe vehicle distance if:

- The chime sounds.
- The vehicle ahead detection indicator and set distance indicator blink.

The warning chime may not sound in some cases when there is a short distance between vehicles. Some examples are:

- When the vehicles are traveling at the same speed and the distance between vehicles is not changing.
- When the vehicle ahead is traveling faster and the distance between vehicles is increasing.
- When a vehicle cuts in at near own vehicle.

The warning chime will not sound when own vehicle approaches vehicles that are parked or moving slowly.

The warning chime will not sound when the accelerator pedal is depressed, overriding the system.

The approach warning chime may sound and the system display may blink when the ICC sensor detects some reflectors which are fitted on vehicles in other lanes or on the side of the road.

This may cause the ICC system to decelerate or accelerate the vehicle.

The ICC sensor may detect these object when the vehicle is driven on winding roads, hilly roads or when entering or exiting a curve.

The ICC sensor may also detect object on narrow roads or in road construction zones.

In these cases driver will have to manually control the proper distance ahead of own vehicle.

Also, the sensor sensitivity can be affected by vehicle operation (steering maneuver or driving position in the lane) or traffic or vehicle condition (for example, if a vehicle is being driven with some damage).



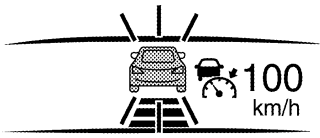

# OPERATION

< SYSTEM DESCRIPTION >

[ICC]

Condition	Display on ICC system display
<p>When own vehicle comes closer to the vehicle ahead and it is judged that the distance between the vehicles is not sufficient</p>	 <p style="text-align: right; font-size: small;">JSOIA1047ZZ</p>

## WARNING LAMP AND AUTOMATIC CANCELLATION DISPLAY

Condition	Description	Display on ICC system display
Warning display	<ul style="list-style-type: none"> <li>When the VDC is turned OFF</li> <li>When the VDC or ABS (including the TCS) operates</li> <li>When a wheel slips</li> <li>When the drive mode select switch is in SNOW mode</li> </ul> <p><b>NOTE:</b> When the conditions listed above are no longer present, turn the system OFF using the MAIN switch. Turn the ICC system back on to use the system.</p>	<p>(Yellow)</p>  <p style="text-align: right; font-size: small;">JSOIA1048ZZ</p>
		<p>Currently unavailable</p>  <p style="text-align: right; font-size: small;">JSOIA0857ZZ</p>
		<p>(Yellow)</p>  <p style="text-align: right; font-size: small;">JSOIA1048ZZ</p>
		<p>Unavailable Front Radar Obstruction</p>  <p style="text-align: right; font-size: small;">JSOIA0857ZZ</p>
<p>When the front bumper grille near the ICC sensor is dirty, making it impossible to detect a vehicle ahead.</p>	<p>A chime sounds and the control is automatically canceled.</p> <p><b>NOTE:</b> Park the vehicle in a safe place, turn the engine OFF. Clean the front bumper grille near the ICC sensor and then perform the settings again.</p>	<p>Unavailable Front Radar Obstruction</p>

# OPERATION

## < SYSTEM DESCRIPTION >

[ICC]

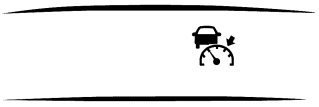
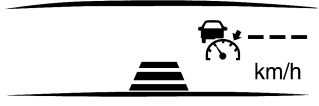
Condition		Description	Display on ICC system display
Warning display	When the ICC system is malfunctioning	A chime sounds and the control is automatically canceled. <b>NOTE:</b> Turn the engine OFF and restart engine. If there is no malfunction, it is possible to set the system.	(Yellow)  JSOIA1049ZZ
Automatic cancellation display	<ul style="list-style-type: none"> <li>When brake pedal is depressed</li> <li>When CANCEL switch is pressed</li> <li>When a vehicle ahead is not detected below the speed of 24 km/h (15 MPH)</li> <li>When the system judges the vehicle is at standstill</li> <li>When the selector lever is not in "D" position or manual mode</li> <li>When the parking brake are applied</li> </ul>	A chime sounds and the control is automatically canceled. <b>NOTE:</b> <ul style="list-style-type: none"> <li>The system will be in a standby, after the control is automatically canceled.</li> <li>A chime sounds when the control is automatically canceled, except when brake pedal is depressed or when CANCEL switch is pressed.</li> </ul>	 JSOIA0845ZZ

**NOTE:**

When the ICC system is automatically canceled, the cancellation condition can be displayed on "WORK SUPPORT" of CONSULT (ICC/ADAS).

## CONVENTIONAL (FIXED SPEED) CRUISE CONTROL MODE FUNCTION

### CONVENTIONAL (FIXED SPEED) CRUISE CONTROL MODE FUNCTION : Switch Name and Function

INFOID:0000000096442.12

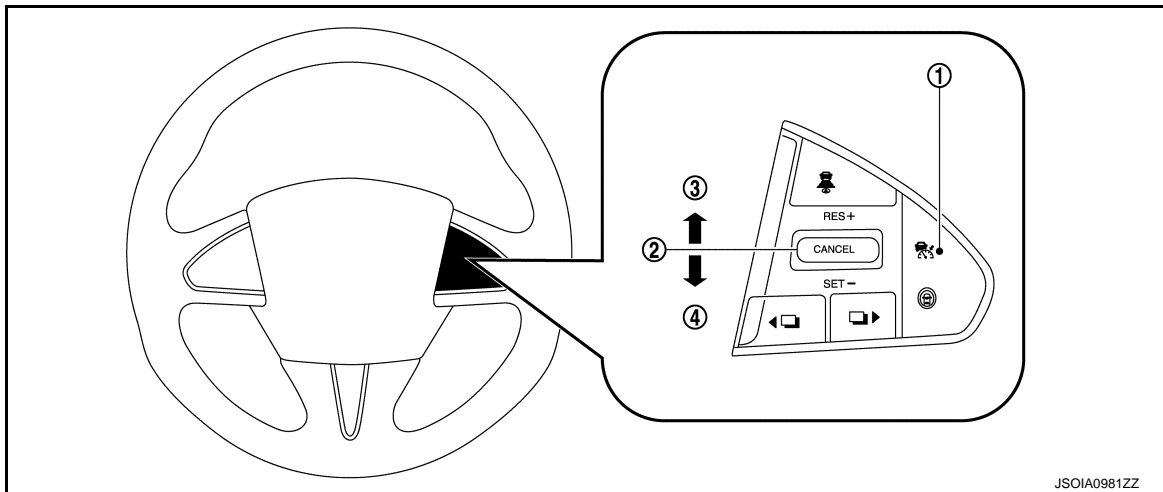

JSOIA0981ZZ

No.	Description	Function
①	MAIN switch	Master switch to activate the system (Press for more than 1.5 seconds)
②	CANCEL switch	Deactivates system without erasing set speed
③	RESUME/ACCELERATE switch	Resumes set speed or increases speed incrementally
④	SET/COAST switch	Sets desired cruise speed or reduces speed incrementally

### CONVENTIONAL (FIXED SPEED) CRUISE CONTROL MODE FUNCTION : Menu



# OPERATION

< SYSTEM DESCRIPTION >

[ICC]

## Displayed by Pressing Each Switch

INFOID:000000009644213

### ICC SYSTEM DISPLAY (ON THE INFORMATION DISPLAY)

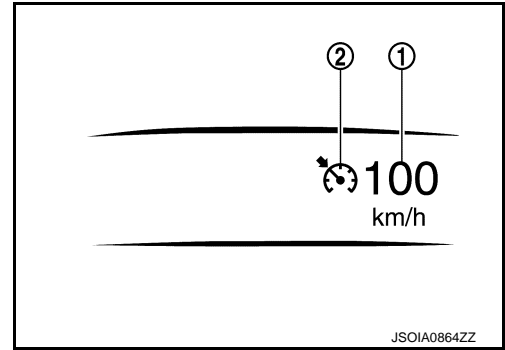

No.	Description	Function
①	Set vehicle speed indicator	Indicates the set vehicle speed
②	ICC system warning (yellow)	Indicates that a malfunction occurs in the ICC system
	MAIN switch indicator (white)	Indicates that the MAIN switch is ON (ICC system ON)
	SET switch indicator (green)	Indicates that the set conventional (fixed speed) cruise control mode is controlled

### SYSTEM CONTROL CONDITION DISPLAY

Push and hold the MAIN switch for longer than approximately 1.5 seconds. This mode will be in a standby state for setting.

Condition	Display on ICC system display
Standby mode	<p style="text-align: right; font-size: small;">JSOIA0865ZZ</p>
Control mode	<p style="text-align: right; font-size: small;">JSOIA0866ZZ</p>

### WARNING AND AUTOMATIC CANCELLATION DISPLAY

CCS

# OPERATION

< SYSTEM DESCRIPTION >

[ICC]

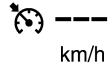
Condition		Description	Display on ICC system display
Warning display	When the ICC system is malfunctioning	A chime sounds and the control is automatically canceled <b>NOTE:</b> Turn the engine OFF and restart engine. If there is no malfunction, it is possible to set the system	(Yellow)    JSOIA0867ZZ
System cancel display	<ul style="list-style-type: none"> <li>• When brake pedal is depressed</li> <li>• When pressing CANCEL switch</li> <li>• When the vehicle slows down more than 13 km/h (8 MPH) below the set speed</li> <li>• When the selector lever is not in the "D" position or manual mode</li> <li>• When the parking brakes are applied</li> <li>• When VDC (including the TCS) operates</li> <li>• When a wheel slips</li> </ul>	A chime sounds and the control is automatically canceled <b>NOTE:</b> <ul style="list-style-type: none"> <li>• The system will be in a standby, after the control is automatically canceled</li> <li>• A chime sounds when the control is automatically canceled, except when brake pedal is depressed or when CANCEL switch is pressed</li> </ul>	(White)    JSOIA0865ZZ

**NOTE:**

When the ICC system is automatically canceled, the cancellation condition can be displayed on "WORK SUPPORT" of CONSULT (ICC/ADAS).

## HANDLING PRECAUTION

### Precautions for Vehicle-to-Vehicle Distance Control Mode

INFOID:000000009644216

- ICC system is only an aid to assist the driver and is not a collision warning or avoidance device. It is the driver's responsibility to stay alert, drive safely and be in control of the vehicle at all times.
- The system is primarily intended for use on straight, dry, open roads with light traffic. It is not advisable to use the system in city traffic or congested areas.
- This system will not adapt automatically to road conditions. This system should be used in evenly flowing traffic. Do not use the system on roads with sharp curves, or on icy roads, in heavy rain or in fog.
- The ICC sensor will not detect under most conditions.
  - Stationary and slow moving vehicles.
  - Pedestrians or objects in the roadway.
  - Oncoming vehicles in the same lane.
  - Motorcycles traveling offset in the travel lane.
- As there is a performance limit to the distance control function, never rely solely on the ICC system. This system does not correct careless, inattentive or absent-minded driving, or overcome poor visibility in rain, fog, or other bad weather. Decelerate the vehicle speed by depressing the brake pedal, depending on the distance to the vehicle ahead and the surrounding circumstances in order to maintain a safe distance between vehicles.
- If the vehicle ahead comes to a stop, the vehicle decelerates to a standstill within the limitations of the system. The system will cancel once it judges that the vehicle has come to a standstill and sound a warning chime. To prevent the vehicle from moving, the driver must depress the brake pedal.
- The system may not detect the vehicle in front of the driver in certain road or weather conditions. To avoid accidents, never use the ICC system under the following conditions:
  - On roads where the traffic is heavy or there are sharp curves.
  - On slippery road surfaces such as on ice or snow, etc.
  - During bad weather (rain, fog, snow, etc.)
  - When rain, snow or dirt adhere to the system sensor.
  - On steep downhill roads (the vehicle may go beyond the set vehicle speed and frequent braking may result in overheating the brakes).
  - On repeated uphill and downhill roads.
  - When traffic conditions make it difficult to keep a proper distance between vehicles because of frequent acceleration or deceleration.
- In some road or traffic conditions, a vehicle or object can unexpectedly come into the sensor detection zone and cause automatic braking. The driver may need to control the distance from other vehicles using the accelerator pedal. Always stay alert and avoid using the ICC system when it is not recommended in this section.
- The vehicle-to-vehicle distance control mode uses a sensor located behind the lower grille of the front bumper to detect vehicles traveling ahead. The sensor generally detects the signals returned from the vehicle ahead. Therefore, if the sensor cannot detect the reflection from the vehicle ahead, the ICC system may not maintain the selected distance.
  - The following are some conditions in which the sensor cannot detect the signals:
    - When the snow or road spray from traveling vehicles reduces the sensor's visibility.
    - When excessively heavy baggage is loaded in the rear seat or the trunk room of own vehicle.
- The ICC system is designed to automatically check the sensor's operation within the limitation of the system. When the sensor area of the front bumper is covered with dirt or is obstructed, the system will automatically be canceled. If the sensor is covered with ice, a transparent or translucent vinyl bag, etc., the ICC system may not detect them. In these instances, the vehicle-to-vehicle distance control mode may not cancel and may not be able to maintain the selected following distance from the vehicle ahead. Be sure to check and clean the sensor regularly.
- The ICC system does not control vehicle speed or warn the driver when own vehicle approaches stationary and slow moving vehicles. The driver must pay attention to vehicle operation to maintain proper distance from vehicles ahead when approaching toll gates or traffic congestion.

A  
B  
C  
D  
E  
F  
G  
H  
I  
J  
K  
L  
M  
N  
P



# HANDLING PRECAUTION

[ICC]

## < SYSTEM DESCRIPTION >

- The detection zone of the ICC sensor is limited. A vehicle ahead must be in the detection zone for the vehicle-to-vehicle distance detection mode to maintain the selected distance from the vehicle ahead. A vehicle ahead may move outside of the detection zone due to its position within the same lane of travel. Motorcycles may not be detected in the same lane ahead if they are traveling offset from the center line of the lane. A vehicle that is entering the lane ahead may not be detected until the vehicle has completely moved into the lane. If this occurs, the ICC system may warn the driver by blinking the system indicator and sounding the chime. The driver may have to manually control the proper distance away from vehicle traveling ahead.

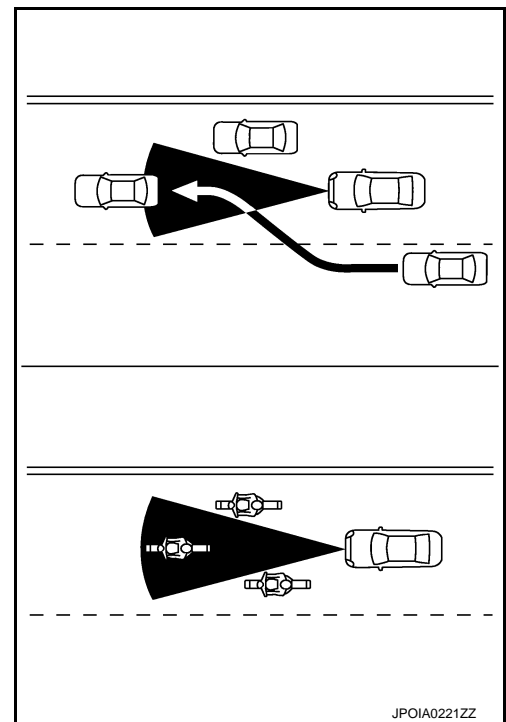

- When driving on some roads, such as winding, hilly, curved, narrow roads, or roads which are under construction, the ICC sensor may detect vehicles in a different lane, or may temporarily not detect a vehicle traveling ahead. This may cause the ICC system to decelerate or accelerate the vehicle. The detection of vehicles may also be affected by vehicle operation (steering maneuver or traveling position in the lane, etc.) or vehicle condition. If this occurs, the ICC system may warn the driver by blinking the system indicator and sounding the chime unexpectedly. The driver will have to manually control the proper distance away from the vehicle traveling ahead.

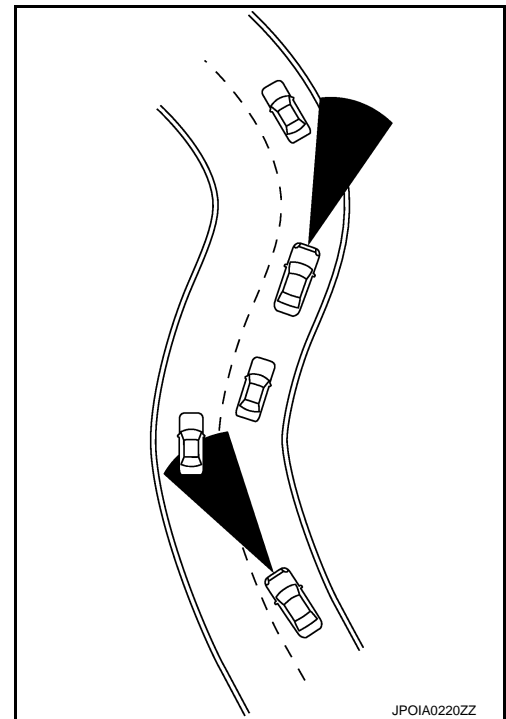

- When driving on the freeway at a set speed and approaching a slower traveling vehicle ahead, the ICC will adjust the speed to maintain the distance, selected by the driver, from the vehicle ahead. If the vehicle ahead changes lanes or exits the freeway, the ICC system will accelerate and maintain the speed up to the set speed. Pay attention to the driving operation to maintain control of the vehicle as it accelerates to the set speed. The vehicle may not maintain the set speed on winding or hilly roads. If this occurs, the driver will have to manually control the vehicle speed.

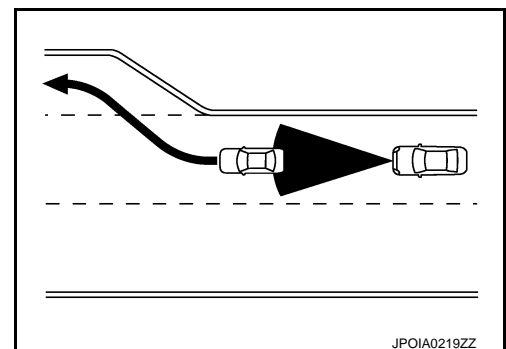

# HANDLING PRECAUTION

< SYSTEM DESCRIPTION >

[ICC]

- Normally when controlling the distance to a vehicle ahead, this system automatically accelerates or decelerates own vehicle according to the speed of the vehicle ahead. Depress the accelerator to properly accelerate own vehicle when acceleration is required for a lane change. Depress the brake pedal when deceleration is required to maintain a safe distance to the vehicle ahead due to its sudden braking or if a vehicle cuts in. Always stay alert when using the ICC system.

A  
B

## Precautions for Conventional (Fixed Speed) Cruise Control Mode

INFOID:000000009644217

- In the conventional (fixed speed) cruise control mode, a warning chime does not sound to warn the driver if own vehicle is too close to the vehicle ahead, as neither the presence of the vehicle ahead nor the vehicle-to-vehicle distance is detected.
- Pay special attention to the distance between own vehicle and the vehicle ahead or a collision could occur.
- Always confirm the setting in the ICC system display.
- Do not use the conventional (fixed speed) cruise control mode when driving under the following conditions:
  - When it is not possible to keep the vehicle at a set speed.
  - In heavy traffic or in traffic that varies in speed.
  - On winding or hilly roads.
  - On slippery roads (rain, snow, ice, etc.).
  - In very windy areas.
  - Doing so could cause a loss of vehicle control and result in an accident.
  - To avoid accidentally engaging cruise control, make sure to turn the MAIN switch off when not using the ICC system.

C  
D  
E  
F  
G

H

I

J

K

L

M

N

CCS

P

## DIAGNOSIS SYSTEM (ADAS CONTROL UNIT)

### On Board Diagnosis Function

INFOID:000000009676505

#### DESCRIPTION

The DTC is displayed on the information display by operating the ICC steering switch.

#### On Board Self-diagnosis System Diagram

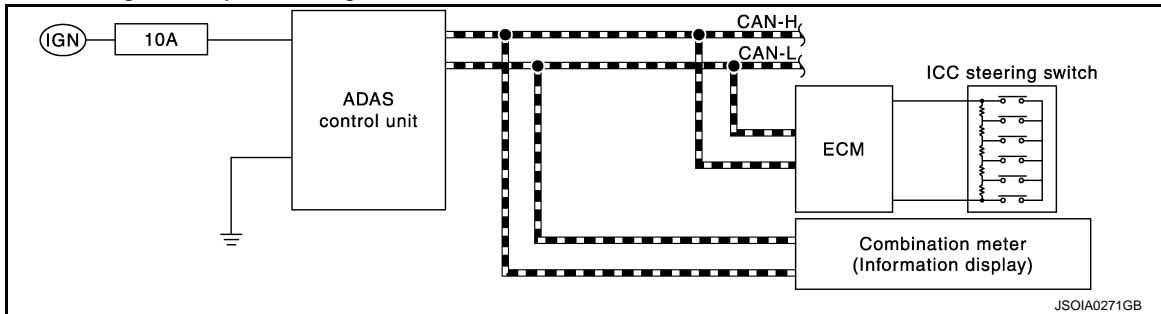

#### METHOD OF STARTING

##### CAUTION:

##### Start condition of on board self-diagnosis

- ICC system OFF
- DCA system OFF
- Vehicle speed 0 km/h (0 MPH)

1. Turn the ignition switch OFF.
2. Start the engine.
3. Wait for 5 seconds after starting the engine. Push up the RESUME/ACCELERATE switch 5 times and push down the SET/COAST switch 5 times within 10 seconds.

##### NOTE:

If the above operation cannot be performed within 10 seconds after waiting for 5 seconds after starting the engine, repeat the procedure from step 1.

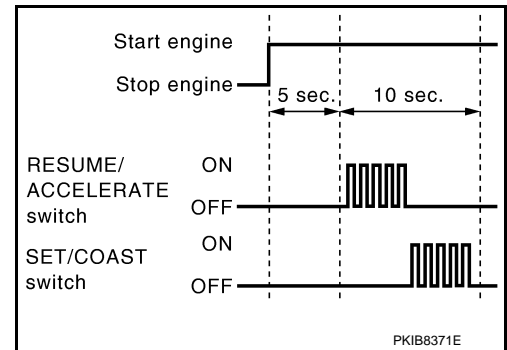

4. The DTC is displayed on the set vehicle speed indicator (1) on the ICC system display on the information display when the on board self-diagnosis starts. Refer to [DAS-44, "DTC Index"](#).

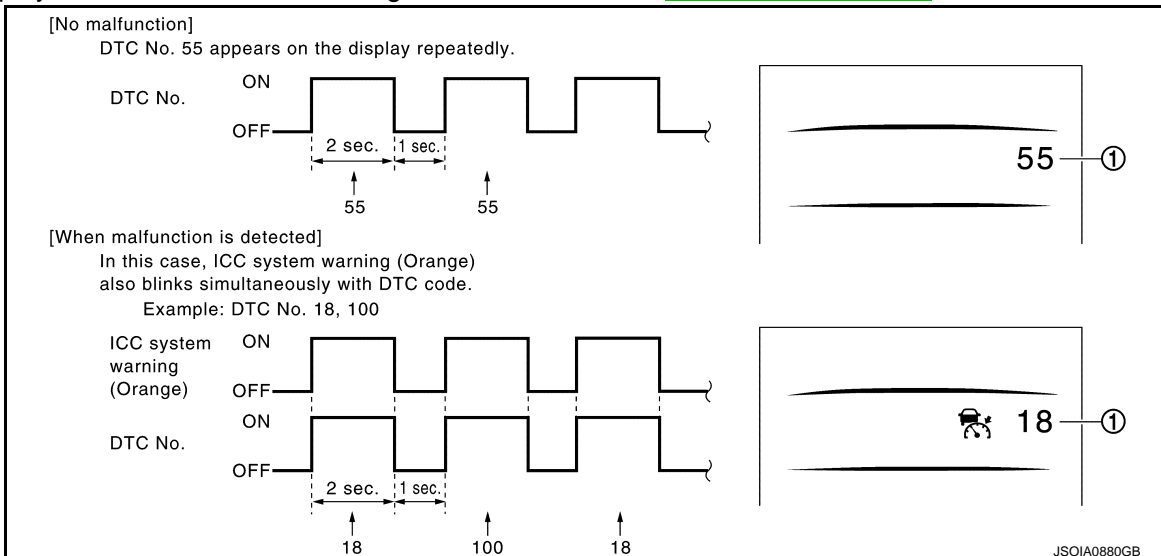

##### NOTE:

# DIAGNOSIS SYSTEM (ADAS CONTROL UNIT)

[ICC]

## < SYSTEM DESCRIPTION >

- It displays for up to 5 minutes and then stops.
- If multiple malfunctions exist, up to 6 DTCs can be stored in memory at the most, and the most recent one is displayed first.

## WHEN THE ON BOARD SELF-DIAGNOSIS DOES NOT START

If the on board self-diagnosis does not start, check the following items.

Assumed abnormal part		Inspection item
Information display	Combination meter malfunction	Check that the self-diagnosis function of the combination meter operates. Refer to <a href="#">MWI-62, "On Board Diagnosis Function"</a> .
ICC steering switch malfunction		Perform the inspection for DTC "C1A06". Refer to <a href="#">DAS-80, "DTC Logic"</a> .
Harness malfunction between ICC steering switch and ECM		
ECM malfunction		
ADAS control unit malfunction		<ul style="list-style-type: none"> <li>• Check power supply and ground circuit of ADAS control unit. Refer to <a href="#">DAS-160, "Diagnosis Procedure"</a>.</li> <li>• Perform SELF-DIAGNOSIS for "ICC/ADAS" with CONSULT, and then check the malfunctioning parts. Refer to <a href="#">DAS-44, "DTC Index"</a>.</li> </ul>

## HOW TO ERASE ON BOARD SELF-DIAGNOSIS

1. Turn the ignition switch OFF.
2. Start the engine, and then start the on board self-diagnosis.
3. Press the CANCEL switch 5 times, and then press the DISTANCE switch 5 times under the condition that the on board self-diagnosis starts.

### NOTE:

- Complete the operation within 10 seconds after pressing the CANCEL switch first.
- If the operation is not completed within 10 seconds, repeat the procedure from step 1.

4. DTC 55 is displayed after erasing.

### NOTE:

DTCs for existing malfunction can not be erased.

5. Turn ignition switch OFF, and finish the diagnosis.

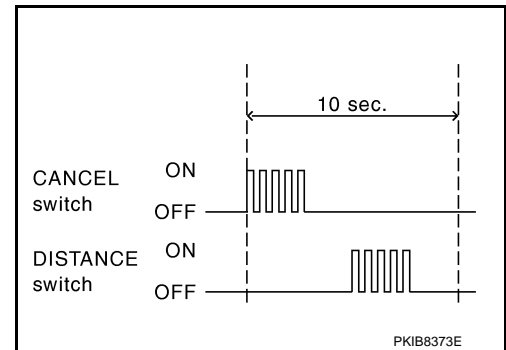

## CONSULT Function (ICC/ADAS)

INFOID:000000009676506

## APPLICATION ITEMS

CONSULT performs the following functions via CAN communication using ADAS control unit.

Diagnosis mode	Description
Configuration	<ul style="list-style-type: none"> <li>• The vehicle specification that is written in ADAS control unit can be displayed or stored</li> <li>• The vehicle specification can be written when ADAS control unit is replaced</li> </ul>
Work Support	Displays causes of automatic system cancellation occurred during system control
Self Diagnostic Result	Displays the name of a malfunctioning system stored in the ADAS control unit
Data Monitor	Displays ADAS control unit input/output data in real time
Active Test	Enables an operational check of a load by transmitting a driving signal from the ADAS control unit to the load
ECU Identification	Displays ADAS control unit part number
CAN Diag Support Monitor	Displays a reception/transmission state of CAN communication and ITS communication

## CONFIGURATION

Configuration includes functions as follows.

# DIAGNOSIS SYSTEM (ADAS CONTROL UNIT)

< SYSTEM DESCRIPTION >

[ICC]

Function		Description
Read/Write Configuration	Before Replace ECU	Allows the reading of vehicle specification written in ADAS control unit to store the specification in CONSULT.
	After Replace ECU	Allows the writing of the vehicle information stored in CONSULT into the ADAS control unit.
Manual Configuration		Allows the writing of the vehicle specification into the ADAS control unit by hand.

## WORK SUPPORT

Work support items	Description
CAUSE OF AUTO-CANCEL 1	Displays causes of automatic system cancellation occurred during control of the following systems <ul style="list-style-type: none"> <li>• Vehicle-to-vehicle control mode</li> <li>• Conventional (fixed speed) control mode</li> <li>• Distance Control Assist (DCA)</li> <li>• Forward Emergency Braking (FEB)</li> </ul>
CAUSE OF AUTO-CANCEL 2	<b>NOTE:</b> The item is displayed, but it is not monitored
CAUSE OF AUTO-CANCEL 3	Displays causes of automatic system cancellation occurred during control of the Back-up Collision Intervention (BCI)

### NOTE:

- Causes of the maximum five cancellations (system cancel) are displayed.
- The displayed cancellation causes display the number of the ignition switch ON/OFF up to 254. It is fixed to 254 if it is over 254. It returns to 0 when the same cancellation cause is detected again.

### Display Items for The Cause of Automatic Cancellation 1

Cause of cancellation					Description
	Vehicle-to-vehicle distance control mode	Conventional (fixed speed) cruise control mode	Distance Control Assist	Forward Emergency Braking	
OPERATING ABS	×		×	×	ABS function was operated
OPERATING TCS	×	×	×		TCS function was operated
OPERATING VDC	×	×	×	×	VDC function was operated
ECM CIRCUIT	×	×			ECM did not permit ICC operation
OPE SW VOLT CIRC	×	×	×		The ICC steering switch input voltage is not within standard range
SNOW MODE SW	×		×		Shifting of the drive mode selector to SNOW position
OP SW DOUBLE TOUCH	×	×			ICC steering switches were pressed at the same time
VHCL SPD DOWN	×	×	×		Vehicle speed lower than the speed as follows <ul style="list-style-type: none"> <li>• Vehicle-to-vehicle distance control mode is 24 km/h (15 MPH)</li> <li>• Conventional (fixed speed) cruise control mode is 32 km/h (20 MPH)</li> </ul>



# DIAGNOSIS SYSTEM (ADAS CONTROL UNIT)

< SYSTEM DESCRIPTION >

[ICC]

WHL SPD ELEC NOISE	×	×	×		Wheel speed sensor signal caught electromagnetic noise	A
VDC/TCS OFF SW	×		×	×	VDC OFF switch was pressed	
VHCL SPD UNMATCH	×	×	×		Wheel speed became different from A/T vehicle speed	
TIRE SLIP	×	×			Wheel slipped	B
IGN LOW VOLT	×	×	×	×	Decrease in ADAS control unit ignition voltage	
PARKING BRAKE ON	×	×			The parking brake is operating	
WHEEL SPD UNMATCH	×	×	×		The wheel speeds of 4 wheels are out of the specified values	C
INCHING LOST	×				A vehicle ahead is not detected during the following driving when the vehicle speed is approximately 24 km/h (15 MPH) or less	
CAN COMM ERROR	×	×	×	×	ADAS control unit received an abnormal signal with CAN communication	D
ABS/TCS/VDC CIRC	×	×	×	×	An abnormal condition occurs in VDC/TCS/ABS system	E
ECD CIRCUIT	×	×	×	×	An abnormal condition occurs in ECD system	
ENG SPEED DOWN	×	×			Engine speed became extremely low while controlling ICC system	
ASCD VHCL SPD DTAC		×			Vehicle speed is detached from set vehicle speed	F
ASCD DOUBLE COMD		×			Cancel switch and operation switch are detected simultaneously	
APA HI TEMP			×		The accelerator pedal actuator integrated motor temperature is high	G
ICC SENSOR CAN COMM ERR	×		×	×	Communication error between ADAS control unit and the ICC sensor	
ABS WARNING LAMP	×		×		ABS warning lamp ON	H
FR RADAR BLOCKED	×		×	×	Inclusion of dirt or stains on the ICC sensor area of the front bumper	
FEB) CURVATURE				×	Road curve was more than the specified value	I
FEB) YAW RATE				×	Detected yawing speed was more than the specified value	
FEB) LTRL ACCELERATION				×	Detected lateral speed is the specified value or more	J
RADAR INTERFERENCE	×		×	×	ICC sensor receives electromagnetic interference	K
NO RECORD	×	×	×		—	L

## Display Items for The Cause of Automatic Cancellation 3

Cause of cancellation	Back-up Collision Intervention	Description
CAN COMM ERROR (CAN)	×	ADAS control unit received an abnormal signal with CAN communication
CAN COMM ERROR (ECD)	×	ADAS control unit received an abnormal signal with CAN communication
IGN LOW VOLT	×	Decrease in ADAS control unit ignition voltage
VEHICLE SPEED UP	×	Vehicle speed higher than 8 km/h (5 MPH)
ACCEL IS OPERATED	×	Accelerator pedal was depressed
BRAKE IS OPERATED	×	Brake pedal was operated
APA HI TEMP	×	The accelerator pedal actuator integrated motor temperature is high

# DIAGNOSIS SYSTEM (ADAS CONTROL UNIT)

[ICC]

## < SYSTEM DESCRIPTION >

Cause of cancellation	Back-up Collision Intervention	Description
APA POWER	×	Decrease in accelerator pedal actuator ignition or battery voltage
NO RECORD	×	—

## SELF DIAGNOSTIC RESULT

Refer to [DAS-44, "DTC Index"](#).

## DATA MONITOR

### NOTE:

The following table includes information (items) inapplicable to this vehicle. For information (items) applicable to this vehicle, refer to CONSULT display items.

Monitored item [Unit]	ALL SIG (ICC)	MAIN SIG (ICC)	MAIN SIG (LDW/LDP)	MAIN SIG (BSW/BSI)	MAIN SIG (BCI)	Description
MAIN SW [On/Off]	×	×	×	×		Indicates [On/Off] status as judged from ICC steering switch
SET/COAST SW [On/Off]	×	×				Indicates [On/Off] status as judged from ICC steering switch
CANCEL SW [On/Off]	×	×				Indicates [On/Off] status as judged from ICC steering switch
RESUME/ACC SW [On/Off]	×	×				Indicates [On/Off] status as judged from ICC steering switch
DISTANCE SW [On/Off]	×					Indicates [On/Off] status as judged from ICC steering switch
CRUISE OPE [On/Off]	×	×				Indicates whether controlling or not (ON means "controlling")
ON ROOT GUID- ANCE [On/Off]	×					<b>NOTE:</b> The item is displayed, but it is not monitored
BRAKE SW [On/Off]	×	×	×	×	×	Indicates [On/Off] status as judged from ICC brake switch signal (ECM transmits ICC brake switch signal through CAN communication)
STOP LAMP SW [On/Off]	×	×	×	×	×	Indicates [On/Off] status as judged from stop lamp switch signal (ECM transmits stop lamp switch signal through CAN communication)
CLUTCH SW SIG [On/Off]	×	×	×	×		Indicates [On/Off] status as judged from clutch pedal position signal (ECM transmits ICC clutch switch signal through CAN communication)
IDLE SW [On/Off]	×				×	Indicates [On/Off] status of idle switch read from ADAS control unit through CAN communication (ECM transmits On/Off status through CAN communication)
SET DISTANCE [Short/Mid/Long]	×	×				Indicates set distance memorized in ADAS control unit
CRUISE LAMP [On/Off]	×	×				Indicates [On/Off] status of MAIN switch indicator output
OWN VHCL [On/Off]	×					Indicates [On/Off] status of own vehicle indicator output

# DIAGNOSIS SYSTEM (ADAS CONTROL UNIT)

< SYSTEM DESCRIPTION >

[ICC]

Monitored item [Unit]	ALL SIG (ICC)	MAIN SIG (ICC)	MAIN SIG (LDW/LDP)	MAIN SIG (BSW/BSI)	MAIN SIG (BCI)	Description
VHCL AHEAD [On/Off]	×					Indicates [On/Off] status of vehicle ahead detection indicator output
ICC WARNING [On/Off]	×					Indicates [On/Off] status of ICC system warning lamp output
VHCL SPEED SE [km/h] or [mph]	×	×	×	×	×	Indicates vehicle speed calculated from ADAS control unit through CAN communication [ABS actuator and electric unit (control unit) transmits vehicle speed signal (wheel speed) through CAN communication]
SET VHCL SPD [km/h] or [mph]	×	×				Indicates set vehicle speed memorized in ADAS control unit
BUZZER O/P [On/Off]	×				×	Indicates [On/Off] status of ICC warning chime output
THRTL SENSOR [deg]	×	×				<b>NOTE:</b> The item is displayed, but it is not monitored
ENGINE RPM [rpm]	×					Indicates engine speed read from ADAS control unit through CAN communication (ECM transmits engine speed signal through CAN communication)
WIPER SW [OFF/LOW/HIGH]	×					Indicates wiper [OFF/LOW/HIGH] status (BCM transmits front wiper request signal through CAN communication)
YAW RATE [deg/s]	×					<b>NOTE:</b> The item is displayed, but it is not monitored
BA WARNING [On/Off]	×					Indicates [On/Off] status of FEB indicator lamp output
STP LMP DRIVE [On/Off]	×	×			×	Indicates [On/Off] status of ICC brake hold relay drive output
D RANGE SW [On/Off]	×					Indicates [On/Off] status of "D" or "M" positions read from ADAS control unit through CAN communication; ON when position "D" or "M" (TCM transmits shift position signal through CAN communication).
NP RANGE SW [On/Off]	×					Indicates shift position signal read from ADAS control unit through CAN communication (TCM transmits shift position signal through CAN communication)
PKB SW [On/Off]	×					Parking brake switch status [On/Off] judged from the parking brake switch signal that ADAS control unit readout via CAN communication is displayed (combination meter transmits the parking brake switch signal via CAN communication)
PWR SUP MONI [V]	×	×				Indicates IGN voltage input by ADAS control unit
VHCL SPD AT [km/h] or [mph]	×					Indicates vehicle speed calculated from A/T vehicle speed sensor read from ADAS control unit through CAN communication (TCM transmits A/T vehicle speed sensor signal through CAN communication)
THRTL OPENING [%]	×	×			×	Indicates throttle position read from ADAS control unit through CAN communication (ECM transmits accelerator pedal position signal through CAN communication).
GEAR [1, 2, 3, 4, 5, 6, 7]	×					Indicates A/T gear position read from ADAS control unit through CAN communication (TCM transmits current gear position signal through CAN communication)
NP SW SIG [On/Off]	×					Indicates [On/Off] status as judged from park/neutral position switch signal (ECM transmits park/neutral position switch signal through CAN communication).
MODE SIG [OFF, ICC, ASCD]	×					Indicates the active mode from ICC or ASCD [conventional (fixed speed) cruise control mode]
SET DISP IND [On/Off]	×					Indicates [On/Off] status of SET switch indicator output

A  
B  
C  
D  
E  
F  
G  
H  
I  
J  
K  
L  
M  
N  
P

CCS

# DIAGNOSIS SYSTEM (ADAS CONTROL UNIT)

< SYSTEM DESCRIPTION >

[ICC]

Monitored item [Unit]	ALL SIG (ICC)	MAIN SIG (ICC)	MAIN SIG (LDW/LDP)	MAIN SIG (BSW/BSI)	MAIN SIG (BCI)	Description
DISTANCE [m]	×					Indicates the distance from the vehicle ahead
RELATIVE SPD [m/s]	×					Indicates the relative speed of the vehicle ahead
DYNA ASIST SW [On/Off]	×	×		×		Indicates [On/Off] status as judged from ICC steering switch signal (ECM transmits ICC steering switch signal through CAN communication)
DCA ON IND [On/Off]	×					The status [ON/OFF] of DCA system switch indicator output is displayed
DCA VHL AHED [On/Off]	×					The status [ON/OFF] of vehicle ahead detection indicator output in DCA system is displayed
IBA SW [On/Off]	×	×				<b>NOTE:</b> The item is displayed, but it is not monitored
FCW SYSTEM ON [On/Off]	×	×				Indicates [On/Off] status of PFCW system
APA TEMP [°C]	×				×	Accelerator pedal actuator integrated motor temperature that the ADAS control unit readout via ITS communication is displayed (Accelerator pedal actuator transmits the integrated motor temperature via ITS communication)
APA PWR [V]	×				×	Accelerator pedal actuator power supply voltage that the ADAS control unit readout via ITS communication is displayed (Accelerator pedal actuator transmits the power supply voltage via ITS communication)
LDW SYSTEM ON [On/Off]			×			Indicates [On/Off] status of LDW system
LDW ON LAMP [On/Off]			×			Indicates [On/Off] status of LDW system display output
LDP ON IND [On/Off]			×			Indicates [On/Off] status of LDP system display output
LANE DPRT W/L [On/Off]			×			Indicates [On/Off] status of LDW/LDP warning display (Yellow) output
LDW BUZER OUT- PUT [On/Off]			×			Indicates [On/Off] status of warning buzzer output
LDP SYSTEM ON [On/Off]			×			Indicates [On/Off] status of LDP system
WARN REQ [On/Off]			×			Indicates an ADAS control unit judged warning state (ON/OFF) of LDP system
READY signal [On/Off]			×			Indicates LDP system settings
Camera lost [Detect/Deviate/Both]			×	×		Indicates a lane marker detection state judged from a lane marker detection signal read by the ADAS control unit via ITS communication (Lane camera unit transmits a lane marker signal via ITS communication)
Shift position [Off, P, R, N, D, M/T1 - 7]			×	×	×	Indicates shift position read from ADAS control unit through CAN communication (TCM transmits shift position signal through CAN communication)
Turn signal [OFF/LH/RH/LH&RH]			×	×		Indicates turn signal operation status read from ADAS control unit through CAN communication (BCM transmits turn indicator signal through CAN communication)
SIDE G [G]			×	×		Indicates lateral G acting on the vehicle. This lateral G is judged from a side G sensor signal read by ADAS control unit via CAN communication (The ABS actuator and electric unit (control unit) transmits a side G sensor signal via CAN communication)

# DIAGNOSIS SYSTEM (ADAS CONTROL UNIT)

< SYSTEM DESCRIPTION >

[ICC]

Monitored item [Unit]	ALL SIG (ICC)	MAIN SIG (ICC)	MAIN SIG (LDW/LDP)	MAIN SIG (BSW/BSI)	MAIN SIG (BCI)	Description
STATUS signal [Stnby/Warn/Cancl/ Off]			×			Indicates a control state of LDP system
Lane unclear [On/Off]			×	×		Indicates an ON/OFF state of the lane marker. The ON/OFF state is judged from a detected lane condition signal read by the ADAS control unit via ITS communication (The lane camera unit transmits a detected lane condition signal via ITS communication)
FUNC ITEM (FCW) [On/Off]	×	×	×	×		Indicates systems which can be set to ON/OFF by selecting "Driver Aids" ⇒ "Emergency Assist" of the integral switch Forward Emergency Braking
FUNC ITEM (LDW) [On/Off]	×	×	×	×		Indicates systems which can be set to ON/OFF by selecting "Driver Aids" ⇒ "Lane" of the integral switch Lane Departure Warning
FUNC ITEM (BSW) [On/Off]	×	×	×	×		Indicates systems which can be set to ON/OFF by selecting "Driver Aids" ⇒ "Blind spot" of the integral switch Blind Spot Warning
FUNC ITEM (NV-ICC) [Off]	×	×	×	×		<b>NOTE:</b> The item is displayed, but it is not monitored
FUNC ITEM (NV-DCA) [Off]	×	×	×	×		<b>NOTE:</b> The item is displayed, but it is not monitored
DCA SELECT [On/Off]	×	×	×	×		Indicates an ON/OFF state of the DCA system. The DCA system can be set to ON/OFF by selecting "Driving Aids" ⇒ "Front assist" of the integral switch
LDP SELECT [On/Off]	×	×	×	×		Indicates an ON/OFF state of LDP system. LDP system can be set to ON/OFF by selecting "Driving Aids" ⇒ "Lane" of the integral switch
BSI SELECT [On/Off]	×	×	×	×		Indicates an ON/OFF state of Blind Spot Intervention system. Blind Spot Intervention system can be set to ON/OFF by selecting "Driving Aids" ⇒ "Blind Spot" of the integral switch
FCW SELECT [On/Off]	×	×	×	×		Indicates an ON/OFF state of the PFCW system. The PFCW system can be set to ON/OFF by selecting "Driving Aids" ⇒ "Emergency Assist" of the integral switch
LDW SELECT [On/Off]	×	×	×	×		Indicates an ON/OFF state of the LDW system. The LDW system can be set to ON/OFF by selecting "Driving Aids" ⇒ "Lane" of the integral switch
BSW SELECT [On/Off]	×	×	×	×		Indicates an ON/OFF state of the BSW system. The BSW system can be set to ON/OFF by selecting "Driving Aids" ⇒ "Blind spot" of the integral switch
NAVI ICC SELECT [Off]	×	×	×	×		<b>NOTE:</b> The item is displayed, but it is not monitored
NAVI DCA SELECT [Off]	×	×	×	×		<b>NOTE:</b> The item is displayed, but it is not monitored
SYS SELECTABILITY [On/Off]	×	×	×	×		Indicates the availability of ON/OFF switching for "Driving Aids" items received from the integral switch via CAN communication
DRIVE MODE STATS [STD/SPORT/ECO/ SNOW/MID/ERROR]	×	×	×	×		Indicates a drive mode selector select position judged from a drive mode select switch position signal read by the ADAS control unit via CAN communication (The chassis control module transmits a switch position signal of the drive mode select switch signal via CAN communication)
WARN SYS SW [On/Off]	×	×	×	×		<b>NOTE:</b> The item is displayed, but it is not monitored
BSW/BSI WARN LMP [On/Off]				×		Indicates [On/Off] status of Blind Spot warning malfunction

A

B

C

D

E

F

G

H

I

J

K

L

M

N

CCS

P

# DIAGNOSIS SYSTEM (ADAS CONTROL UNIT)

< SYSTEM DESCRIPTION >

[ICC]

Monitored item [Unit]	ALL SIG (ICC)	MAIN SIG (ICC)	MAIN SIG (LDW/LDP)	MAIN SIG (BSW/BSI)	MAIN SIG (BCI)	Description
BSI ON IND [On/Off]				×		Indicates [On/Off] status of Blind Spot Intervention system display
BSW SYSTEM ON [On/Off]				×		Indicates [On/Off] status of BSW system
BSI SYSTEM ON [On/Off]				×		Indicates [On/Off] status of Blind Spot Intervention system
BCI SYSTEM ON [On/Off]					×	Indicates [On/Off] status of BCI system
BATTERY CIRCUIT OFF [On/Off]	×					<b>NOTE:</b> The item is displayed, but it is not used
LDP WARNING INDI- CATOR [On/Off]			×			Indicates [On/Off] status of LDP warning display (Yellow) output
LDW ON INDICATOR [On/Off]			×			Indicates [On/Off] status of LDW system ON display output
LDW WARNING INDI- CATOR [On/Off]			×			Indicates [On/Off] status of LDW system warning display output
SYSTEM CANCEL MESSAGE [NOREQ/SLIP/ SNOW/VDC OFF]	×	×	×	×		Indicates [On/Off] status of system cancel display output
CAMERA HI TEMP MSG [On/Off]			×	×		Indicates [On/Off] status of lane camera unit high temperature warning display output
ITS SETTING ITEM(DCA) [On/Off]	×	×	×	×		Indicates the presence or absence of DCA system.
ITS SETTING ITEM(LDP) [On/Off]	×	×	×	×		Indicates the presence or absence of LDP system.
ITS SETTING ITEM(BSI) [On/Off]	×	×	×	×		Indicates the presence or absence of Blind Spot Intervention system.
BSI WARNING INDI- CATOR [On/Off]				×		Indicates [On/Off] status of Blind Spot Intervention warning display output
BSW ON INDICATOR [On/Off]				×		Indicates [On/Off] status of BSW system ON display output
SIDE RADAR BLOCK COND [On/Off]				×		Indicates [On/Off] status of side radar with dirt or foreign materials
LDW WARNING ALERT TIMING [Nothing/Early/Late]			×			<b>NOTE:</b> The item is displayed, but it is not monitored
BSW IND BRIGHT- NESS [Nothing/Bright/Nor- mal/Dark]				×		Indicates status of brightness of Blind Spot Warning/Blind Spot Intervention indicator
SL MAIN SW [On/Off]		×				Indicates [On/Off] status as judged from steering switch

# DIAGNOSIS SYSTEM (ADAS CONTROL UNIT)

< SYSTEM DESCRIPTION >

[ICC]

Monitored item [Unit]	ALL SIG (ICC)	MAIN SIG (ICC)	MAIN SIG (LDW/LDP)	MAIN SIG (BSW/BSI)	MAIN SIG (BCI)	Description
FUNC ITEM(FEB) [On/Off]	×					Indicates systems which can be set to ON/OFF by selecting "Driver Aids" ⇒ "Emergency Assist" of the integral switch Forward Emergency Braking
FEB SELECT [On/Off]	×					Indicates an ON/OFF state of the FEB system. The FEB system can be set to ON/OFF by selecting "Driving Aids" ⇒ "Emergency Assist" of the integral switch
FEB SW [On/Off]	×					Indicates [On/Off] status of FEB system
SL TARGET VEHI- CLE SPEED [km/h]	×					Indicates set vehicle speed memorized in ADAS control unit
SL SET LAMP [On/Off]	×					Indicates [On/Off] status of speed limiter SET display output
SL LIMIT LAMP [On/Off]	×					Indicates [On/Off] status of speed limiter MAIN switch display output
ASCD CANCEL (LOW SPEED) [NON/CUT]	×					Indicates the vehicle cruise condition. <ul style="list-style-type: none"> <li>• NON: Vehicle speed is maintained at the ASCD set speed.</li> <li>• CUT: Vehicle speed decreased to excessively low, and ASCD operation is cut off.</li> </ul>
ASCD CANCEL (SPEED DIFF) [NON/CUT]	×					Indicates the vehicle cruise condition. <ul style="list-style-type: none"> <li>• NON: Vehicle speed is maintained at the ASCD set speed.</li> <li>• CUT: Vehicle speed decreased to excessively low compared with the ASCD set speed, and ASCD operation is cut off.</li> </ul>
KICK DOWN [On/Off]	×					Display Kick Down decision state. <ul style="list-style-type: none"> <li>• On: Accelerator pedal is depressed</li> <li>• Off: Accelerator pedal is fully released</li> </ul>

## ACTIVE TEST

### CAUTION:

- **Never perform "Active Test" while driving the vehicle.**
- **The "Active Test" cannot be performed when the following systems malfunction is displayed.**
  - ICC system
  - DCA
  - LDW
  - LDP
  - Blind Spot Warning
  - Blind Spot Intervention
  - BCI
- **The "Active Test" cannot be performed when the FEB warning lamp is illuminated.**
- **Shift the selector lever to "P" position, and then perform the test.**

Test item	Description
METER LAMP	The MAIN switch indicator and FEB warning lamp can be illuminated by ON/OFF operations as necessary
STOP LAMP	The ICC brake hold relay can be operated by ON/OFF operations as necessary, and the stop lamp can be illuminated
ICC BUZZER	Sounds a buzzer used for following systems by arbitrarily operating ON/OFF <ul style="list-style-type: none"> <li>• Intelligent Cruise Control (ICC)</li> <li>• Distance Control Assist (DCA)</li> <li>• Predictive Forward Collision Warning (PFCW)</li> <li>• Forward Emergency Brake (FEB)</li> </ul>
BRAKE ACTUATOR	Activates the brake by an arbitrary operation
ACTIVE PEDAL	The accelerator pedal actuator can be operated as necessary
DCA INDICATOR	The DCA system display can be illuminated by ON/OFF operations as necessary

# DIAGNOSIS SYSTEM (ADAS CONTROL UNIT)

< SYSTEM DESCRIPTION >

[ICC]

Test item	Description
LDP BUZZER	Sounds a buzzer used for following systems by arbitrarily operating ON/OFF <ul style="list-style-type: none"> <li>• Lane Departure Warning (LDW)</li> <li>• Lane Departure Prevention (LDP)</li> <li>• Blind Spot Warning (BSW)</li> <li>• Blind Spot Intervention</li> </ul>
LDP ON IND	The LDP system display can be illuminated by ON/OFF operations as necessary
LANE DEPARTURE W/L	The LDW/LDP warning can be illuminated by ON/OFF operations as necessary
BSW ON INDICATOR	The Blind Spot Warning system display can be illuminated by ON/OFF operations as necessary
BSI ON INDICATOR	The Blind Spot Intervention system display can be illuminated by ON/OFF operations as necessary
LDW ON INDICATOR	The LDW system display can be illuminated by ON/OFF operations as necessary
LDP WARNING INDICATOR	The LDP malfunction can be illuminated by ON/OFF operations as necessary
LDW WARNING INDICATOR	The LDW malfunction can be illuminated by ON/OFF operations as necessary
BSW WARNING INDICATOR	The BSW malfunction can be illuminated by ON/OFF operations as necessary
BSI WARNING INDICATOR	The Blind Spot Intervention malfunction can be illuminated by ON/OFF operations as necessary

## METER LAMP

### NOTE:

The test can be performed only when the engine is running.

Test item	Operation	Description	<ul style="list-style-type: none"> <li>• MAIN switch indicator</li> <li>• ICC system warning</li> <li>• FEB warning lamp</li> </ul>
METER LAMP	Off	Stops sending the following signals to exit from the test <ul style="list-style-type: none"> <li>• Meter display signal</li> <li>• FEB warning lamp signal</li> </ul>	OFF
	On	Transmits the following signals to the combination meter via CAN communication <ul style="list-style-type: none"> <li>• Meter display signal</li> <li>• FEB warning lamp signal</li> </ul>	ON

## STOP LAMP

Test item	Operation	Description	Stop lamp
STOP LAMP	Off	Stops transmitting the ICC brake hold relay drive signal below to end the test	OFF
	On	Transmits the ICC brake hold relay drive signal	ON

## ICC BUZZER

Test item	Operation	Description	Operation sound
ICC BUZZER	MODE1	Transmits the buzzer output signals to the driver assistance buzzer control module via ITS communication	Intermittent beep sound
	Test start	Starts the tests of "MODE1"	—
	Reset	Stops transmitting the buzzer output signal below to end the test	—
	End	Returns to the "SELECT TEST ITEM" screen	—

## BRAKE ACTUATOR

### NOTE:

The test can be performed only when the engine is running.



# DIAGNOSIS SYSTEM (ADAS CONTROL UNIT)

< SYSTEM DESCRIPTION >

[ICC]

Test item	Operation	Description	"PRESS SENS" value
BRAKE ACTUATOR	MODE1	Transmits the brake fluid pressure control signal to the ABS actuator and electric unit (control unit) via chassis control module	10 bar
	MODE2		20 bar
	MODE3		30 bar
	Test start	Starts the tests of "MODE1", "MODE2" and "MODE3"	—
	Reset	Stops transmitting the brake fluid pressure control signal below to end the test	—
	End	Returns to the "SELECT TEST ITEM" screen	—

**NOTE:**

The test is finished in 10 seconds after starting

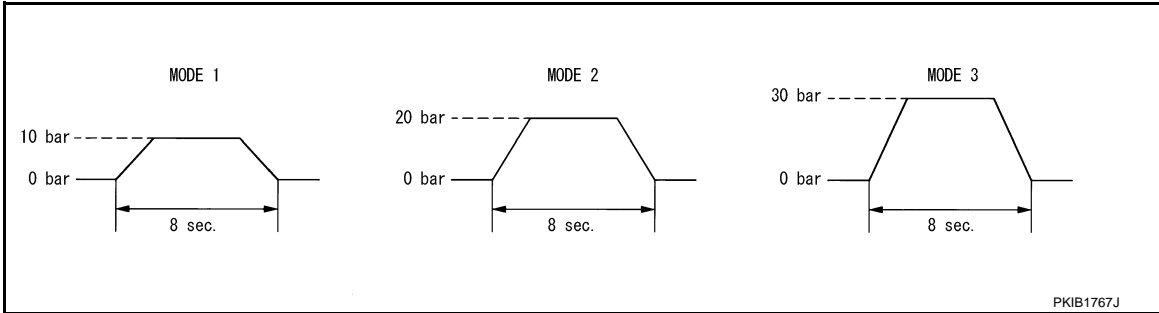

Active Pedal

**CAUTION:**

- Shift the selector lever to "P" position, and then perform the test.
- Never depress the accelerator pedal excessively. (The engine speed may rise unexpectedly when finishing the test.)

**NOTE:**

- Depress the accelerator pedal to check when performing the test.
- The test can be performed only when the engine is running.

Test item	Operation	Description	Accelerator pedal operation
ACTIVE PEDAL	MODE1	Transmit the accelerator pedal feedback force control signal to the accelerator pedal actuator via ITS communication.	Constant with a force of 25 N for 8 seconds
	MODE2		Constant with a force of 15 N for 8 seconds
	MODE3		Change up to a force of 25 N for 8 seconds
	MODE4		Change up to a force of 15 N for 8 seconds
	Test start	Starts the tests of "MODE1", "MODE2", "MODE3" and "MODE4"	—
	Reset	Stops transmitting the accelerator pedal feedback force control signal below to end the test.	—
	End	Returns to the "SELECT TEST ITEM" screen	—

**NOTE:**

CCS

# DIAGNOSIS SYSTEM (ADAS CONTROL UNIT)

[ICC]

## < SYSTEM DESCRIPTION >

The test is finished in 10 seconds after starting

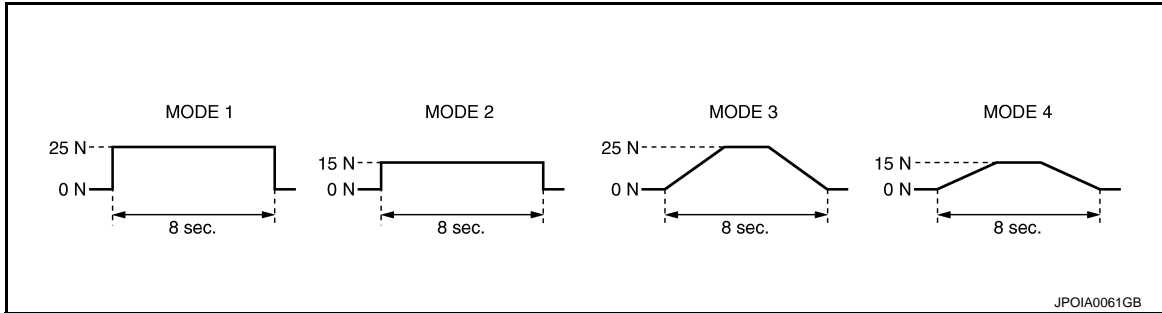

### DCA INDICATOR

**NOTE:**

The test can be performed only when the engine is running.

Test item	Operation	Description	DCA system display
DCA INDICATOR	Off	Stops transmitting the meter display signal below to end the test	—
	On	Transmits the meter display signal to the combination meter via CAN communication	ON

### LDP BUZZER

Test item	Operation	Description	Warning buzzer
LDP BUZZER	Off	Stops transmitting the warning buzzer signal below to end the test	—
	On	Transmits the warning buzzer signal to the warning buzzer	ON

### LDP ON IND

Test item	Operation	Description	LDP system display (Green)
LDP ON IND	Off	Stops transmitting the meter display signal below to end the test	—
	On	Transmits the meter display signal to the combination meter via CAN communication	ON

### LANE DEPARTURE W/L

Test item	Operation	Description	Lane departure system display (Yellow)
LANE DEPARTURE W/L	Off	Stops transmitting the meter display signal below to end the test	—
	On	Transmits the meter display signal to the combination meter via CAN communication	ON

### BSW ON INDICATOR

Test item	Operation	Description	Blind Spot Warning system display (Yellow)
BSW ON INDICATOR	Off	Stops transmitting the meter display signal below to end the test	—
	On	Transmits the meter display signal to the combination meter via CAN communication	ON

### BSI ON INDICATOR

# DIAGNOSIS SYSTEM (ADAS CONTROL UNIT)

< SYSTEM DESCRIPTION >

[ICC]

Test item	Operation	Description	Blind Spot Intervention system display (Green)
BSI ON INDICATOR	Off	Stops transmitting the meter display signal below to end the test	—
	On	Transmits the meter display signal to the combination meter via CAN communication	ON

A  
B

## LDW ON INDICATOR

C

Test item	Operation	Description	LDW system display (White)
LDW ON INDICATOR	Off	Stops transmitting the meter display signal below to end the test	—
	On	Transmits the meter display signal to the combination meter via CAN communication	ON

D  
E

## LDP WARNING INDICATOR

F

Test item	Operation	Description	LDP malfunction (Yellow)
LDP WARNING INDICATOR	Off	Stops transmitting the meter display signal below to end the test	—
	On	Transmits the meter display signal to the combination meter via CAN communication	ON

G  
H

## LDW WARNING INDICATOR

I

Test item	Operation	Description	LDW malfunction (Yellow)
LDW WARNING INDICATOR	Off	Stops transmitting the meter display signal below to end the test	—
	On	Transmits the meter display signal to the combination meter via CAN communication	ON

J  
K

## BSW WARNING INDICATOR

L

Test item	Operation	Description	BSW malfunction (Yellow)
BSW WARNING INDICATOR	Off	Stops transmitting the meter display signal below to end the test	—
	On	Transmits the meter display signal to the combination meter via CAN communication	ON

M  
N

## BSI WARNING INDICATOR

CCS

Test item	Operation	Description	Blind Spot Intervention malfunction (Yellow)
BSI WARNING INDICATOR	Off	Stops transmitting the meter display signal below to end the test	—
	On	Transmits the meter display signal to the combination meter via CAN communication	ON

P

# DIAGNOSIS SYSTEM (ICC SENSOR)

< SYSTEM DESCRIPTION >

[ICC]

## DIAGNOSIS SYSTEM (ICC SENSOR)

### CONSULT Function (LASER/RADAR)

INFOID:000000009644220

#### APPLICATION ITEMS

CONSULT performs the following functions via CAN communication with ADAS control unit and the communication with ICC sensor.

Diagnosis mode	Description
Work Support	It can monitor the adjustment direction indication in order to perform the radar alignment operation smoothly
Self Diagnostic Result	Displays malfunctioning system memorized in ICC sensor
Data Monitor	Displays real-time input/output data of ICC sensor
ECU Identification	Displays ICC sensor part number
CAN Diag Support Monitor	The results of transmit/receive diagnosis of ITS communication can be read

#### WORK SUPPORT

Work support items	Description
MILLIWAVE RADAR ADJUST	Outputs millimeter waves, calculates dislocation of the millimeter waves, and indicates adjustment direction

#### Radar Alignment

Refer to [CCS-83, "TYPE 1 : Description"](#).

#### SELF DIAGNOSTIC RESULT

Refer to [CCS-63, "DTC Index"](#).

#### DATA MONITOR

##### NOTE:

The following table includes information (items) inapplicable to this vehicle. For information (items) applicable to this vehicle, refer to CONSULT display items.

Monitored item [Unit]	Description
VHCL SPEED SE [km/h] or [mph]	Vehicle speed judged from a vehicle speed signal read by the ICC sensor via ITS communication is displayed [ADAS control unit receives a vehicle speed signal from ABS actuator and electric unit (control unit) via CAN communication and transmits the calculated vehicle speed to ICC sensor via ITS communication]
YAW RATE [deg/s]	Indicates yaw rate read from ADAS control unit through ITS communication (ADAS control unit receives yaw rate signal from ABS actuator and electric unit (control unit) via CAN communication and transmits yaw rate calculated by the ADAS control unit) Yaw rate judged from a yaw rate signal read by ICC sensor via ITS communication is displayed [ADAS control unit receives a yaw rate signal from ABS actuator and electric unit (control unit) via CAN communication and transmits the calculated yaw rate to ICC sensor via ITS communication]
PWR SUP MONI [V]	Indicates IGN voltage input by ICC sensor
DISTANCE [m]	Indicates the distance from the vehicle ahead
RELATIVE SPD [m/s]	Indicates the relative speed of the vehicle ahead
RADAR OFFSET [m]	<b>NOTE:</b> The item is indicated, but not used
RADAR HEIGHT [m]	<b>NOTE:</b> The item is indicated, but not used
STEERING ANGLE [deg]	The steering angle is displayed

# DIAGNOSIS SYSTEM (ICC SENSOR)

< SYSTEM DESCRIPTION >

[ICC]

Monitored item [Unit]	Description
STRG ANGLE SPEED [deg/s]	The steering angle speed is displayed
L/R ADJUST	The horizontal correction value of the radar is displayed
U/D ADJUST	The vertical correction value of the radar is displayed

A

B

C

D

E

F

G

H

I

J

K

L

M

N

CCS

P

# DIAGNOSIS SYSTEM (DRIVER ASSISTANCE BUZZER CONTROL MODULE)

< SYSTEM DESCRIPTION >

[ICC]

## DIAGNOSIS SYSTEM (DRIVER ASSISTANCE BUZZER CONTROL MODULE)

### CONSULT Function (BSW/BUZZER)

INFOID:000000009791211

#### DESCRIPTION

CONSULT performs the following functions via CAN communication with ADAS control unit and the communication with driver assistance buzzer control module.

Test mode	Function
Self Diagnostic Result	<ul style="list-style-type: none"><li>• Displays malfunctioning system memorized in driver assistance buzzer control module</li><li>• Displays the Freeze Frame Data when the malfunction is detected</li></ul>
DATA MONITOR	Displays real-time input/output data of driver assistance buzzer control module
ACTIVE TEST	Enables operation check of electrical loads by sending driving signal to them
ECU Identification	Displays driver assistance buzzer control module parts number

#### SELF DIAGNOSTIC RESULT

##### Self Diagnostic Result

Refer to [DAS-280, "DTC Index"](#).

##### FFD (Freeze Frame Data)

The drive assistance buzzer control module records the following data when the malfunction is detected.

Freeze Frame Data item [Unit]	Description
IGN Counter <sup>Note</sup>	It displays number of ignition switch OFF → ON after the malfunction is detected

#### NOTE:

- The number is 0 when is detected now.
- The number increases like 1 → 2 ... 38 → 39 after returning to the normal condition whenever IGN OFF → ON.
- The number is fixed to 39 until the self-diagnosis results are erased if it is over 39.

#### DATA MONITOR

##### NOTE:

The following table includes information (items) inapplicable to this vehicle. For information (items) applicable to this vehicle, refer to CONSULT display items.

Monitor item [Unit]	FUNCTION DESCRIPTION
Buzzer 1 request (ADAS) [Off/TYPE 1 - 3/Cancel]	Indicates buzzer request type status as judged from ADAS control unit through ITS communication (The ADAS control unit transmits the driver assistance buzzer signal via ITS communication)
Buzzer 1 volume (ADAS) [Vol. 1- 16]	Indicates buzzer volume status as judged from ADAS control unit through ITS communication (The ADAS control unit transmits the driver assistance buzzer signal via ITS communication)
Buzzer 1 stop (ADAS) [CYCLE/IMEDIAT]	Indicates buzzer stop status as judged from ADAS control unit through ITS communication (The ADAS control unit transmits the driver assistance buzzer signal via ITS communication)
Buzzer 2 request (ADAS) [Off/TYPE 1 - 3/Cancel]	Indicates buzzer request type status as judged from ADAS control unit through ITS communication (The ADAS control unit transmits the driver assistance buzzer signal via ITS communication)
Buzzer 2 volume (ADAS) [Vol. 1- 16]	Indicates buzzer volume status as judged from ADAS control unit through ITS communication (The ADAS control unit transmits the driver assistance buzzer signal via ITS communication)
Buzzer 2 stop (ADAS) [CYCLE/IMEDIAT]	Indicates buzzer stop status as judged from ADAS control unit through ITS communication (The ADAS control unit transmits the driver assistance buzzer signal via ITS communication)
Buzzer 3 request (ADAS) [Off/TYPE 1/Cancel]	Indicates buzzer request type status as judged from ADAS control unit through ITS communication (The ADAS control unit transmits the driver assistance buzzer signal via ITS communication)
Buzzer 3 volume (ADAS) [Vol. 1- 16]	Indicates buzzer volume status as judged from ADAS control unit through ITS communication (The ADAS control unit transmits the driver assistance buzzer signal via ITS communication)

# DIAGNOSIS SYSTEM (DRIVER ASSISTANCE BUZZER CONTROL MODULE)

< SYSTEM DESCRIPTION >

[ICC]

Monitor item [Unit]	FUNCTION DESCRIPTION
Buzzer 3 stop (ADAS) [CYCLE/IMEDIAT]	Indicates buzzer stop status as judged from ADAS control unit through ITS communication (The ADAS control unit transmits the driver assistance buzzer signal via ITS communication)
Buzzer 4 request (ADAS) [Off/TYPE 1 - 7/Cancel]	Indicates buzzer request type status as judged from ADAS control unit through ITS communication (The ADAS control unit transmits the driver assistance buzzer signal via ITS communication)
Buzzer 4 volume (ADAS) [Vol. 1- 16]	Indicates buzzer volume status as judged from ADAS control unit through ITS communication (The ADAS control unit transmits the driver assistance buzzer signal via ITS communication)
Buzzer 4 stop (ADAS) [CYCLE/IMEDIAT]	Indicates buzzer stop status as judged from ADAS control unit through ITS communication (The ADAS control unit transmits the driver assistance buzzer signal via ITS communication)
Buzzer 1 request (CCM) [Off/TYPE 1 - 3/Cancel]	Indicates buzzer request type status as judged from chassis control module through chassis communication (The ADAS control unit transmits the driver assistance buzzer signal via chassis communication)
Buzzer 1 volume (CCM) [Vol. 1- 16]	Indicates buzzer volume status as judged from chassis control module through chassis communication (The ADAS control unit transmits the driver assistance buzzer signal via chassis communication)
Buzzer 1 stop (CCM) [CYCLE/IMEDIAT]	Indicates buzzer stop status as judged from chassis control module through chassis communication (The ADAS control unit transmits the driver assistance buzzer signal via chassis communication)
Buzzer 2 request (CCM) [Off/TYPE 1 - 3/Cancel]	Indicates buzzer request type status as judged from chassis control module through chassis communication (The ADAS control unit transmits the driver assistance buzzer signal via chassis communication)
Buzzer 2 volume (CCM) [Vol. 1- 16]	Indicates buzzer volume status as judged from chassis control module through chassis communication (The ADAS control unit transmits the driver assistance buzzer signal via chassis communication)
Buzzer 2 stop (CCM) [CYCLE/IMEDIAT]	Indicates buzzer stop status as judged from chassis control module through chassis communication (The ADAS control unit transmits the driver assistance buzzer signal via chassis communication)
Buzzer 3 request (CCM) [Off/TYPE 1/Cancel]	Indicates buzzer request type status as judged from chassis control module through chassis communication (The ADAS control unit transmits the driver assistance buzzer signal via chassis communication)
Buzzer 3 volume (CCM) [Vol. 1- 16]	Indicates buzzer volume status as judged from chassis control module through chassis communication (The ADAS control unit transmits the driver assistance buzzer signal via chassis communication)
Buzzer 3 stop (CCM) [CYCLE/IMEDIAT]	Indicates buzzer stop status as judged from chassis control module through chassis communication (The ADAS control unit transmits the driver assistance buzzer signal via chassis communication)
Buzzer 4 request (CCM) [Off/TYPE 1 - 7/Cancel]	Indicates buzzer request type status as judged from chassis control module through chassis communication (The ADAS control unit transmits the driver assistance buzzer signal via chassis communication)
Buzzer 4 volume (CCM) [Vol. 1- 16]	Indicates buzzer volume status as judged from chassis control module through chassis communication (The ADAS control unit transmits the driver assistance buzzer signal via chassis communication)
Buzzer 4 stop (CCM) [CYCLE/IMEDIAT]	Indicates buzzer stop status as judged from chassis control module through chassis communication (The ADAS control unit transmits the driver assistance buzzer signal via chassis communication)
ADAS MALFUNCTION [Off/On]	Indicates ADAS control unit status
CCM MALFUNCTION [Off/On]	Indicates chassis control module status
DR ASSIST BUZZ MALF [Off/On]	Indicates driver assistance control buzzer module status
DR ASSIST BUZZ STATUS [1/2/3/1, 2/2, 4/1, 4/4]	Indicates driver assistance control buzzer sound status

## ACTIVE TEST

### CAUTION:

**Never perform ACTIVE TEST while driving the vehicle.**

Item list

A  
B  
C  
D  
E  
F  
G  
H  
I  
J  
K  
L  
M  
N  
P

CCS

# DIAGNOSIS SYSTEM (DRIVER ASSISTANCE BUZZER CONTROL MODULE)

< SYSTEM DESCRIPTION >

[ICC]

Active test item	Description
BUZZER 1 (ADAS)	Sounds a buzzer used for following systems by arbitrarily operating ON/OFF <ul style="list-style-type: none"><li>• Lane Departure Warning (LDW)</li><li>• Blind Spot Warning (BSW)</li><li>• Blind Spot Intervention</li></ul>
BUZZER 2 (ADAS)	Sounds a buzzer used for following systems by arbitrarily operating ON/OFF <ul style="list-style-type: none"><li>• Intelligent Cruise Control (ICC)</li><li>• Predictive Forward Collision Warning (PFCW)</li><li>• Distance Control Assist (DCA)</li></ul>
BUZZER 3 (ADAS)	Sounds a buzzer used for following systems by arbitrarily operating ON/OFF <ul style="list-style-type: none"><li>• Forward Emergency Braking (FEB)</li></ul>
BUZZER 4 (ADAS)	Sounds a buzzer used for following systems by arbitrarily operating ON/OFF <ul style="list-style-type: none"><li>• Predictive Forward Collision Warning (PFCW)</li></ul>
BUZZER 1 (CCM)	Sounds a buzzer used for following systems by arbitrarily operating ON/OFF <ul style="list-style-type: none"><li>• Lane Departure Warning (LDW)</li><li>• Blind Spot Warning (BSW)</li><li>• Blind Spot Intervention</li></ul>
BUZZER 2 (CCM)	Sounds a buzzer used for following systems by arbitrarily operating ON/OFF <ul style="list-style-type: none"><li>• Intelligent Cruise Control (ICC)</li><li>• Predictive Forward Collision Warning (PFCW)</li><li>• Distance Control Assist (DCA)</li></ul>
BUZZER 3 (CCM)	Sounds a buzzer used for following systems by arbitrarily operating ON/OFF <ul style="list-style-type: none"><li>• Forward Emergency Braking (FEB)</li></ul>
BUZZER 4 (CCM)	Sounds a buzzer used for following systems by arbitrarily operating ON/OFF <ul style="list-style-type: none"><li>• Predictive Forward Collision Warning (PFCW)</li></ul>

## BUZZER 1 (ADAS)

Active test item	Operation	Description
BUZZER 1 (ADAS)	Off	Stops transmitting the warning buzzer signal below to end of the test
	On	Transmits the warning buzzer signal to the warning buzzer

## BUZZER 2 (ADAS)

Active test item	Operation	Description
BUZZER 2 (ADAS)	Off	Stops transmitting the warning buzzer signal below to end of the test
	On	Transmits the warning buzzer signal to the warning buzzer

## BUZZER 3 (ADAS)

Active test item	Operation	Description
BUZZER 3 (ADAS)	Off	Stops transmitting the warning buzzer signal below to end of the test
	On	Transmits the warning buzzer signal to the warning buzzer

## BUZZER 4 (ADAS)

Active test item	Operation	Description
BUZZER 4 (ADAS)	Off	Stops transmitting the warning buzzer signal below to end of the test
	On	Transmits the warning buzzer signal to the warning buzzer

## BUZZER 1 (CCM)

Active test item	Operation	Description
BUZZER 1 (CCM)	Off	Stops transmitting the warning buzzer signal below to end of the test
	On	Transmits the warning buzzer signal to the warning buzzer



# DIAGNOSIS SYSTEM (DRIVER ASSISTANCE BUZZER CONTROL MODULE)

< SYSTEM DESCRIPTION >

[ICC]

## BUZZER 2 (CCM)

Active test item	Operation	Description
BUZZER 2 (CCM)	Off	Stops transmitting the warning buzzer signal below to end of the test
	On	Transmits the warning buzzer signal to the warning buzzer

## BUZZER 3 (CCM)

Active test item	Operation	Description
BUZZER 3 (CCM)	Off	Stops transmitting the warning buzzer signal below to end of the test
	On	Transmits the warning buzzer signal to the warning buzzer

## BUZZER 4 (CCM)

Active test item	Operation	Description
BUZZER 4 (CCM)	Off	Stops transmitting the warning buzzer signal below to end of the test
	On	Transmits the warning buzzer signal to the warning buzzer

## ECU IDENTIFICATION

Displays driver assistance buzzer control module parts number.

A  
B  
C  
D  
E  
F  
G  
H  
I  
J  
K  
L  
M  
N  
P

CCS

# ADAS CONTROL UNIT

< ECU DIAGNOSIS INFORMATION >

[ICC]

## ECU DIAGNOSIS INFORMATION

### ADAS CONTROL UNIT

#### Reference Value

INFOID:000000009676507

#### VALUES ON THE DIAGNOSIS TOOL

##### NOTE:

The following table includes information (items) inapplicable to this vehicle. For information (items) applicable to this vehicle, refer to CONSULT display items.

Monitor item	Condition		Value/Status
MAIN SW	Ignition switch ON	When MAIN switch is pressed	On
		When MAIN switch is not pressed	Off
SET/COAST SW	Ignition switch ON	When SET/COAST switch is pressed	On
		When SET/COAST switch is not pressed	Off
CANCEL SW	Ignition switch ON	When CANCEL switch is pressed	On
		When CANCEL switch is not pressed	Off
RESUME/ACC SW	Ignition switch ON	When RESUME/ACCELERATE switch is pressed	On
		When RESUME/ACCELERATE switch is not pressed	Off
DISTANCE SW	Ignition switch ON	When DISTANCE switch is pressed	On
		When DISTANCE switch is not pressed	Off
CRUISE OPE	Drive the vehicle and activate the vehicle-to-vehicle distance control mode	When ICC system is controlling	On
		When ICC system is not controlling	Off
BRAKE SW	Ignition switch ON	When brake or clutch pedal is depressed	Off
		When brake or clutch pedal is not depressed	On
STOP LAMP SW	Ignition switch ON	When brake pedal is depressed	On
		When brake pedal is not depressed	Off
IDLE SW	Engine running	Idling	On
		Except idling (depress accelerator pedal)	Off
SET DISTANCE	<ul style="list-style-type: none"> <li>Start the engine and turn the ICC system ON</li> <li>Press the DISTANCE switch to change the vehicle-to-vehicle distance setting</li> </ul>	When set to "long"	Long
		When set to "middle"	Mid
		When set to "short"	Short
CRUISE LAMP	Start the engine and press MAIN switch	ICC system ON (MAIN switch indicator ON)	On
		ICC system OFF (MAIN switch indicator OFF)	Off
OWN VHCL	<b>NOTE:</b> The item is indicated, but not monitored		Off
VHCL AHEAD	Drive the vehicle and activate the vehicle-to-vehicle distance control mode	When a vehicle ahead is detected (vehicle ahead detection indicator ON)	On
		When a vehicle ahead is not detected (vehicle ahead detection indicator OFF)	Off
ICC WARNING	Start the engine and press MAIN switch	When ICC system is malfunctioning (ICC system malfunction ON)	On
		When ICC system is normal (ICC system malfunction OFF)	Off

# ADAS CONTROL UNIT

< ECU DIAGNOSIS INFORMATION >

[ICC]

Monitor item	Condition		Value/Status
VHCL SPEED SE	While driving		Displays the vehicle speed calculated by ADAS control unit
SET VHCL SPD	While driving	When vehicle speed is set	Displays the set vehicle speed
BUZZER O/P	Engine running	When the buzzer of the following system operates <ul style="list-style-type: none"> <li>• Vehicle-to-vehicle distance control mode</li> <li>• DCA system</li> <li>• PFCW system</li> <li>• FEB system</li> </ul>	On
		When the buzzer of the following system not operates <ul style="list-style-type: none"> <li>• Vehicle-to-vehicle distance control mode</li> <li>• DCA system</li> <li>• PFCW system</li> <li>• FEB system</li> </ul>	Off
THRTL SENSOR	<b>NOTE:</b> The item is indicated, but not monitored		0.0
ENGINE RPM	Engine running		Equivalent to tachometer reading
WIPER SW	Ignition switch ON	Wiper not operating	Off
		Wiper LO operation	Low
		Wiper HI operation	High
YAW RATE	<b>NOTE:</b> The item is indicated, but not monitored		0.0
BA WARNING	Engine running	FEB OFF indicator lamp ON <ul style="list-style-type: none"> <li>• When FEB system is malfunctioning</li> <li>• When FEB system is turned to OFF</li> </ul>	On
		FEB OFF indicator lamp OFF <ul style="list-style-type: none"> <li>• When FEB system is normal</li> <li>• When FEB system is turned to ON</li> </ul>	Off
STP LMP DRIVE	Drive the vehicle and activate the vehicle-to-vehicle distance control mode	When ICC brake hold relay is activated	On
		When ICC brake hold relay is not activated	Off
D RANGE SW	Engine running	When the selector lever is in "D" position or manual mode	On
		When the selector lever is in any position other than "D" or manual mode	Off
NP RANGE SW	Engine running	When the selector lever is in "N", "P" position	On
		When the selector lever is in any position other than "N", "P"	Off
PKB SW	Ignition switch ON	When the parking brake is applied	On
		When the parking brake is released	Off
PWR SUP MONI	Engine running		Power supply voltage value of ADAS control unit
VHCL SPD AT	While driving		Value of A/T vehicle speed sensor signal
THRTL OPENING	Engine running	Depress accelerator pedal	Displays the throttle position

A  
B  
C  
D  
E  
F  
G  
H  
I  
J  
K  
L  
M  
N  
P

CCS

# ADAS CONTROL UNIT

< ECU DIAGNOSIS INFORMATION >

[ICC]

Monitor item	Condition		Value/Status
GEAR	While driving		Displays the gear position
CLUTCH SW SIG	Ignition switch ON	When clutch or brake pedal is depressed	On
		When clutch or brake pedal is not depressed	Off
NP SW SIG	Ignition switch ON	When the shift lever is in neutral position	On
		When the shift lever is in any position other than neutral	Off
MODE SIG	Start the engine and press MAIN switch	When ICC system is deactivated	Off
		When vehicle-to-vehicle distance control mode is activated	ICC
		When conventional (fixed speed) cruise control mode is activated	ASCD
SET DISP IND	<ul style="list-style-type: none"> <li>• Drive the vehicle and activate the conventional (fixed speed) cruise control mode</li> <li>• Press SET/COAST switch</li> </ul>	SET switch indicator ON	On
		SET switch indicator OFF	Off
DISTANCE	Drive the vehicle and activate the vehicle-to-vehicle distance control mode	When a vehicle ahead is detected	Displays the distance from the preceding vehicle
		When a vehicle ahead is not detected	0.0
RELATIVE SPD	Drive the vehicle and activate the vehicle-to-vehicle distance control mode	When a vehicle ahead is detected	Displays the relative speed.
		When a vehicle ahead is not detected	0.0
DYNA ASIST SW	Ignition switch ON	When dynamic driver assistance switch is pressed	On
		When dynamic driver assistance switch is not pressed	Off
DCA ON IND	Start the engine and press dynamic driver assistance switch (When DCA setting is ON)	DCA system OFF	Off
		DCA system ON	On
DCA VHL AHED	Drive the vehicle and activate the DCA system	When a vehicle ahead is not detected (vehicle ahead detection indicator OFF)	Off
		When a vehicle ahead is detected (vehicle ahead detection indicator ON)	On
IBA SW	<b>NOTE:</b> The item is indicated, but not monitored		Off
FCW SYSTEM ON	Ignition switch ON	When the PFCW system is ON	On
		When the PFCW system is OFF	Off
APA TEMP	Engine running		Display the accelerator pedal actuator integrated motor temperature
APA PWR	Ignition switch ON		Power supply voltage value of accelerator pedal actuator
LDW SYSTEM ON	Ignition switch ON	When the LDW system is ON	On
		When the LDW system is OFF	Off
LDW ON LAMP	Ignition switch ON	When the LDW system is ON	On
		When the LDW system is OFF	Off

# ADAS CONTROL UNIT

< ECU DIAGNOSIS INFORMATION >

[ICC]

Monitor item	Condition		Value/Status
LDP ON IND	Start the engine and press dynamic driver assistance switch (When LDP system setting is ON)	LDP ON indicator lamp ON	On
		LDP ON indicator lamp OFF	Off
LANE DPRT W/L	Drive the vehicle and activate the LDW system or LDP system	Lane departure warning lamp ON	On
		Lane departure warning lamp OFF	Off
LDW BUZER OUT-PUT	Drive the vehicle and activate the LDW/LDP system or Blind Spot Warning/Blind Spot Intervention system	When the buzzer of the following system operates • LDW/LDP system • Blind Spot Warning/Blind Spot Intervention system	On
		When the buzzer of the following system does not operate • LDW/LDP system • Blind Spot Warning/Blind Spot Intervention system	Off
LDP SYSTEM ON	Start the engine and press dynamic driver assistance switch (When LDP system setting is ON)	When the LDP system is ON	On
		When the LDP system is OFF	Off
READY signal	Start the engine and press dynamic driver assistance switch (When LDP system setting is ON)	When the LDP system is ON	On
		When the LDP system is OFF	Off
Camera lost	Drive the vehicle and activate the LDW system, LDP system or Blind Spot Intervention system	Both side lane markers are detected	Detect
		Deviated side lane marker is lost	Deviated
		Both side lane markers are lost	Both
Shift position	<ul style="list-style-type: none"> <li>• Engine running</li> <li>• While driving</li> </ul>		Displays the shift position
Turn signal	Turn signal lamps OFF		Off
	Turn signal lamp LH blinking		LH
	Turn signal lamp RH blinking		RH
	Turn signal lamp LH and RH blinking		LH&RH
SIDE G	While driving	Vehicle turning right	Negative value
		Vehicle turning left	Positive value
WARN REQ	Drive the vehicle and activate the LDP system	Lane departure warning is operating	On
		Lane departure warning is not operating	Off
STATUS signal	Drive the vehicle and activate the LDP system	When the LDP system is ON	Stnby
		When the LDP system is operating	Warn
		When the LDP system is canceled	Cancel
		When the LDP system is OFF	Off
Lane unclear	While driving	Lane marker is unclear	On
		Lane marker is clear	Off
FUNC ITEM	Ignition switch ON		FUNC3
FUNC ITEM (NV-ICC)	<b>NOTE:</b> The item is indicated, but not monitored		Off
FUNC ITEM (NV-DCA)	<b>NOTE:</b> The item is indicated, but not monitored		Off
DCA SELECT	Ignition switch ON	"Distance Control Assist" set with the integral switch is ON	On
		"Distance Control Assist" set with the integral switch is OFF	Off

A  
B  
C  
D  
E  
F  
G  
H  
I  
J  
K  
L  
M  
N

CCS

P

# ADAS CONTROL UNIT

< ECU DIAGNOSIS INFORMATION >

[ICC]

Monitor item	Condition		Value/Status
LDP SELECT	Ignition switch ON	"Lane Departure Intervention" set with the integral switch is ON	On
		"Lane Departure Intervention" set with the integral switch is OFF	Off
BSI SELECT	Ignition switch ON	"Blind Spot Intervention" set with the integral switch is ON	On
		"Blind Spot Intervention" set with the integral switch is OFF	Off
FCW SELECT	Ignition switch ON	"Forward Emergency Braking" set with the integral switch is ON	On
		"Forward Emergency Braking" set with the integral switch is OFF	Off
LDW SELECT	Ignition switch ON	"Lane Departure Warning" set with the integral switch is ON	On
		"Lane Departure Warning" set with the integral switch is OFF	Off
BSW SELECT	Ignition switch ON	"Blind Spot Warning" set with the integral switch is ON	On
		"Blind Spot Warning" set with the integral switch is OFF	Off
NAVI ICC SELECT	<b>NOTE:</b> The item is indicated, but not monitored		Off
NAVI DCA SELECT	<b>NOTE:</b> The item is indicated, but not monitored		Off
SYS SELECTABILITY	Ignition switch ON	Items set with the integral switch can be switched normally	On
		Items set with the integral switch cannot be switched normally	Off
DRIVE MODE STATS	Ignition switch ON	When drive mode select switch position is STANDARD	STD
		When drive mode select switch position is in SPORT	SPORT
		When drive mode select switch position is in ECO	ECO
		When drive mode select switch position is in SNOW	SNOW
		When drive mode select switch position is in PERSONAL	STD
		A signal other than those above is input	ERROR
WARN SYS SW	<b>NOTE:</b> The item is indicated, but not monitored		Off
BSW/BSI WARN LMP	Ignition switch ON	When the BSW system is malfunctioning	On
		When the BSW system is normal	Off
BSI ON IND	Ignition switch ON	Blind Spot Intervention warning ON	On
		Blind Spot Intervention warning OFF	Off
BSW SYSTEM ON	Ignition switch ON	When the BSW system is ON	On
		When the BSW system is OFF	Off
BSI SYSTEM ON	Start the engine and press dynamic driver assistance switch (When Blind Spot Intervention system setting is ON)	When the Blind Spot Intervention system is ON	On
		When the Blind Spot Intervention system is OFF	Off
BCI SYSTEM ON	Engine running	When the BCI system is ON	On
		When the BCI system is OFF	Off
BCI SWITCH	<b>NOTE:</b> The item is indicated, but not monitored		Off

# ADAS CONTROL UNIT

< ECU DIAGNOSIS INFORMATION >

[ICC]

Monitor item	Condition		Value/Status
BATTERY CIRCUIT OFF	<b>NOTE:</b> The item is indicated, but not used		Off
LDP WARNING INDICATOR	Engine running	When the LDP system is malfunctioning	On
		When the LDP system is normal	Off
LDW ON INDICATOR	Ignition switch ON	LDW system display ON	On
		LDW system display OFF	Off
LDW WARNING INDICATOR	Ignition switch ON	When the LDW system is malfunctioning	On
		When the LDW system is normal	Off
SYSTEM CANCEL MESSAGE	Ignition switch ON	System cancel display ON	On
		System cancel display OFF	Off
CAMERA HI TEMP MSG	Ignition switch ON	Lane camera unit high temperature warning display ON	On
		Lane camera unit high temperature warning display OFF	Off
ITS SETTING ITEM(DCA)	Ignition switch ON		On
ITS SETTING ITEM(LDP)	Ignition switch ON		On
ITS SETTING ITEM(BSI)	Ignition switch ON		On
BSI WARNING INDICATOR	Engine running	When the Blind Spot Intervention is malfunctioning	On
		When the Blind Spot Intervention is normal	Off
BSW ON INDICATOR	Ignition switch ON	BSW system display ON	On
		BSW system display OFF	Off
SIDE RADAR BLOCK COND	Ignition switch ON	Front bumper or side radar is dirty	On
		Front bumper and side radar is clean	Off
LDW WARNING ALERT TIMING	Ignition switch ON	LDW system OFF	Nothing
		Lane departure warning timing is early setting	Early
		Lane departure warning timing is late setting	Late
BSW IND BRIGHTNESS	Ignition switch ON	BSW system OFF	Nothing
		Blind Spot Warning/Blind Spot Intervention indicator brightness bright	Bright
		Blind Spot Warning/Blind Spot Intervention indicator brightness normal	Normal
		Blind Spot Warning/Blind Spot Intervention indicator brightness dark	Dark
FUNC ITEM (FEB)	Engine running	"Forward Emergency Braking" set with the integral switch is ON	On
		"Forward Emergency Braking" set with the integral switch is OFF	Off
FEB SELECT	Ignition switch ON	"Forward Emergency Braking" set with the integral switch is ON	On
		"Forward Emergency Braking" set with the integral switch is OFF	Off
FEB SW	Engine running	FEB system ON	On
		FEB system OFF	Off
SL MAIN SW	Engine running	When speed limiter MAIN switch is pressed	On
		When speed limiter MAIN switch is not pressed	Off

A

B

C

D

E

F

G

H

I

J

K

L

M

N

CCS

P

# ADAS CONTROL UNIT

< ECU DIAGNOSIS INFORMATION >

[ICC]

Monitor item	Condition		Value/Status
SL TARGET VEHI- CLE SPEED	While driving	When vehicle speed is set	Displays the set vehicle speed
SL SET LAMP	<ul style="list-style-type: none"> <li>Drive the vehicle and activate the speed limiter</li> <li>Press speed limiter MAIN switch</li> </ul>	Speed limiter SET indicator ON	On
		Speed limiter SET indicator OFF	Off
SL LIMIT LAMP	<ul style="list-style-type: none"> <li>Drive the vehicle and activate the speed limiter</li> <li>Press speed limiter MAIN switch</li> </ul>	Speed limiter system ON	On
		Speed limiter system OFF	Off
ASCDCANCEL (LOW SPEED)	Drive the vehicle and activate the ASCD	ASCDCancelled by low vehicle speed	On
		Other than above	Off
ASCDCANCEL (SPEED DIFF)	Drive the vehicle and activate the ASCD	ASCDCancelled by difference between set speed and vehicle speed	On
		Other than above	Off
KICK DOWN	Drive the vehicle and activate the speed limiter	When accelerator pedal is full depressed	On
		Other than above	Off

TERMINAL LAYOUT  
PHYSICAL VALUES

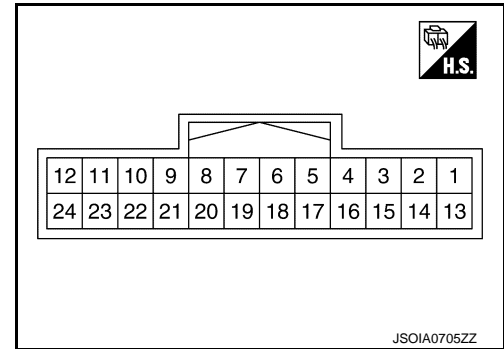

Terminal No. (Wire color)		Description		Condition	Standard value	Reference value	
+	-	Signal name	Input/ Output				
1 (L)	Ground	CAN -H	—	—	—	—	
2 (R)		CAN -L	—	—	—	—	
5 (B)		Ground	—	Ignition switch ON	0 - 0.1 V	Approx. 0 V	
6 (L)		ITS communication-H	—	—	—	—	
7 (P)		ITS communication-L	—	—	—	—	
8 (L)		Chassis communication-H	—	—	—	—	
9 (V)		Chassis communication-L	—	—	—	—	
12 (GR)		Ignition power supply	Input	Ignition switch ON	—	10 - 16 V	Battery voltage
17 (V)		ICC brake hold relay drive signal	Output	Ignition switch ON	—	10 - 16 V	Approx. 12 V
	At "STOP LAMP" test of "Active test"				0 - 0.1 V	Approx. 0 V	



# ADAS CONTROL UNIT

< ECU DIAGNOSIS INFORMATION >

[ICC]

## Fail-safe (ADAS Control Unit)

INFOID:000000009676508

If a malfunction occurs in each system, ADAS control unit cancels each control, sounds a beep, and turns ON the warning or indicator lamp.

System	Buzzer	Warning lamp/Warning display	Description
Vehicle-to-vehicle distance control mode	High-pitched tone	ICC system warning	Cancel
Conventional (fixed speed) cruise control mode	High-pitched tone	ICC system warning	Cancel
Forward Emergency Braking (FEB)	High-pitched tone	<ul style="list-style-type: none"> <li>• FEB warning lamp</li> <li>• Warning systems indicator (Forward position: Yellow)</li> </ul>	Cancel
Predictive Forward Collision Warning (PFCW)	High-pitched tone	Warning systems indicator (Forward position: Yellow)	Cancel
Distance Control Assist (DCA)	High-pitched tone	Warning systems indicator (Forward position: Yellow)	Cancel
Blind Spot Warning (BSW)	—	Warning systems indicator (Blind spot position: Yellow)	Cancel
Back-up Collision Intervention (BCI)	High-pitched tone	BCI system warning	Cancel

## DTC Inspection Priority Chart

INFOID:000000009676509

If multiple DTCs are detected simultaneously, check them one by one depending on the following DTC inspection priority chart.

Priority	Detected items (DTC)
1	<ul style="list-style-type: none"> <li>• U1507: LOST COMM (SIDE RDR R)</li> <li>• U1508: LOST COMM (SIDE RDR L)</li> </ul>
2	<ul style="list-style-type: none"> <li>• 1CA0A: CONFIG UNFINISHED</li> <li>• U1000: CAN COMM CIRCUIT</li> <li>• U1010: CONTROL UNIT (CAN)</li> </ul>
3	<ul style="list-style-type: none"> <li>• C1F02: APA C/U MALF</li> <li>• C1B53: SIDE RDR R MALF</li> <li>• C1B54: SIDE RDR L MALF</li> <li>• C1B84: DIST SEN MALFUNCTION</li> </ul>

CCS

# ADAS CONTROL UNIT

< ECU DIAGNOSIS INFORMATION >

[ICC]

Priority	Detected items (DTC)	
4	<ul style="list-style-type: none"> <li>• C1A01: POWER SUPPLY CIR</li> <li>• C1A02: POWER SUPPLY CIR 2</li> <li>• C1A04: ABS/TCS/VDC CIRC</li> <li>• C1A05: BRAKE SW/STOP L SW</li> <li>• C1A06: OPERATION SW CIRC</li> <li>• C1A13: STOP LAMP RLY FIX</li> <li>• C1A14: ECM CIRCUIT</li> <li>• C1A24: NP RANGE</li> <li>• C1A26: ECD MODE MALF</li> <li>• C1A27: ECD PWR SUPPLY CIR</li> <li>• C1A33: CAN TRANSMISSION ERR</li> <li>• C1A34: COMMAND ERROR</li> <li>• C1A35: APA CIR</li> <li>• C1A36: APA CAN COMM CIR</li> <li>• C1A37: APA CAN CIR 2</li> <li>• C1A38: APA CAN CIR 1</li> <li>• C1A39: STRG SEN CIR</li> <li>• C1B5D: FEB OPE COUNT LIMIT</li> <li>• C1B56: SONAR CIRCUIT</li> <li>• C1B57: AVM CIRCUIT</li> <li>• C1B59: CCM CIRCUIT</li> <li>• C1B82: DIST SEN OFF-CENTER</li> <li>• C1B85: DIST SEN ABNORMAL TEMP</li> <li>• C1B86: DIST SEN PWR SUP CIR</li> <li>• C1F01: APA MOTOR MALF</li> <li>• C1F05: APA PWR SUPPLY CIR</li> </ul>	<ul style="list-style-type: none"> <li>• U0121: VDC CAN CIR 2</li> <li>• U0126: STRG SEN CAN CIR 1</li> <li>• U0235: ICC SENSOR CAN CIRC 1</li> <li>• U0401: ECM CAN CIR 1</li> <li>• U0402: TCM CAN CIR 1</li> <li>• U0415: VDC CAN CIR 1</li> <li>• U0424: HVAC CAN CIR 1</li> <li>• U0428: STRG SEN CAN CIR 2</li> <li>• U1502: ICC SEN CAN COMM CIR</li> <li>• U1503: SIDE RDR L CAN CIR 2</li> <li>• U1504: SIDE RDR L CAN CIR 1</li> <li>• U1505: SIDE RDR R CAN CIR 2</li> <li>• U1506: SIDE RDR R CAN CIR 1</li> <li>• U150B: ECM CAN CIR 3</li> <li>• U150C: VDC CAN CIRC 3</li> <li>• U150D: TCM CAN CIRC 3</li> <li>• U150E: BCM CAN CIRC 3</li> <li>• U150F: AV CAN CIRC 3</li> <li>• U1512: HVAC CAN CIRC3</li> <li>• U1513: METER CAN CIRC 3</li> <li>• U1514: STRG SEN CAN CIRC 3</li> <li>• U1515: ICC SENSOR CAN CIRC 3</li> <li>• U1517: APA CAN CIRC 3</li> <li>• U1518: SIDE RDR L CAN CIRC 3</li> <li>• U1519: SIDE RDR R CAN CIRC 3</li> <li>• U1521: SONAR CAN COMMUNICATION 3</li> <li>• U1522: SONAR CAN COMMUNICATION 3</li> <li>• U1523: SONAR CAN COMMUNICATION 2</li> <li>• U1524: AVM CAN COMMUNICATION 1</li> <li>• U1525: AVM CAN COMMUNICATION 3</li> <li>• U1527: CCM CAN CIR 1</li> <li>• U153F: CCM CAN CIR 2</li> <li>• U1530: DR ASSIST BUZZER CAN CIR 1</li> <li>• U1540: DAST 3 CAN CIR 1</li> <li>• U1541: DAST 3 CAN CIR 2</li> </ul>
5	<ul style="list-style-type: none"> <li>• C1A03: VHCL SPEED SE CIRC</li> </ul>	
6	<ul style="list-style-type: none"> <li>• C1A15: GEAR POSITION</li> </ul>	
7	<ul style="list-style-type: none"> <li>• C1A00: CONTROL UNIT</li> </ul>	

## DTC Index

INFOID:000000009676510

### NOTE:

- The details of time display are as per the following.
- CRNT: A malfunction is detected now
- PAST: A malfunction was detected in the past
- IGN counter is displayed on FFD (Freeze Frame Data).
- 0: The malfunctions that are detected now  
CAN communication system (U1000, U1010)
- 1 - 39: It increases like 0 → 1 → 2 ... 38 → 39 after returning to the normal condition whenever the ignition switch OFF → ON. It returns to 0 when a malfunction is detected again in the process.
- If it is over 39, it is fixed to 39 until the self-diagnosis results are erased.  
Other than CAN communication system (Other than U1000, U1010)
- 1 - 49: It increases like 0 → 1 → 2 ... 38 → 49 after returning to the normal condition whenever the ignition switch OFF → ON. It returns to 0 when a malfunction is detected again in the process.
- If it is over 49, it is fixed to 49 until the self-diagnosis results are erased.

# ADAS CONTROL UNIT

< ECU DIAGNOSIS INFORMATION >

[ICC]

Systems for fail-safe

- A: Vehicle-to-vehicle distance control mode
- B: Conventional (fixed speed) cruise control mode
- C: Distance Control Assist (DCA)
- D: Forward Emergency Braking (FEB)
- E: Predictive Forward Collision Warning (PFCW)
- F: Blind Spot Warning (BSW)
- G: Back-up Collision Intervention (BCI)

DTC		CONSULT display	Fail-safe	Reference
CONSULT	On board display		System	
NO DTC IS DETECTED. FURTHER TESTING MAY BE REQUIRED	55	NO DTC IS DETECTED. FURTHER TESTING MAY BE REQUIRED	—	—
C1A0A	41	CONFIG UNFINISHED	A, B, C, D, E, F, G	<a href="#">DAS-69</a>
C1A00	0	CONTROL UNIT	A, B, C, D, E, F, G	<a href="#">DAS-70</a>
C1A01	1	POWER SUPPLY CIR	A, B, C, D, E, F, G	<a href="#">DAS-71</a>
C1A02	2	POWER SUPPLY CIR 2	A, B, C, D, E, F, G	<a href="#">DAS-71</a>
C1A03	3	VHCL SPEED SE CIRC	A, B, C, D, E, F, G	<a href="#">DAS-72</a>
C1A04	4	ABS/TCS/VDC CIRC	A, B, C, D, E, F, G	<a href="#">DAS-74</a>
C1A05	5	BRAKE SW/STOP L SW	A, B, C, D, G	<a href="#">DAS-75</a>
C1A06	6	OPERATION SW CIRC	A, B, C, D, E	<a href="#">DAS-80</a>
C1A13	13	STOP LAMP RLY FIX	A, B, C, D, E, G	<a href="#">DAS-83</a>
C1A14	14	ECM CIRCUIT	A, B, C, D, E	<a href="#">DAS-89</a>
C1A15	15	GEAR POSITION	A, B, C, D, E	<a href="#">DAS-91</a>
C1A24	24	NP RANGE	A, B, C, D, E, F, G	<a href="#">DAS-93</a>
C1A26	26	ECD MODE MALF	A, B, C, D, G	<a href="#">DAS-95</a>
C1A27	27	ECD PWR SUPPLY CIR	A, B, C, D, G	<a href="#">DAS-97</a>
C1A33	33	CAN TRANSMISSION ERR	A, B, C, D, E	<a href="#">DAS-99</a>
C1A34	34	COMMAND ERROR	A, B, C, D, E	<a href="#">DAS-100</a>
C1A35	35	APA CIR	A, C, D, E	<a href="#">DAS-101</a>
C1A36	36	APA CAN COMM CIR	A, C, D, E	<a href="#">DAS-102</a>
C1A37	133	APA CAN CIR 2	A, C, D, E	<a href="#">DAS-103</a>
C1A38	132	APA CAN CIR 1	A, C, D, E	<a href="#">DAS-104</a>
C1A39	39	STRG SEN CIR	A, B, C, D, E, F, G	<a href="#">DAS-105</a>
C1B5D	198	FEB OPE COUNT LIMIT	C, D, E	<a href="#">DAS-106</a>
C1B53	84	SIDE RDR R MALF	F, G	<a href="#">DAS-107</a>
C1B54	85	SIDE RDR L MALF	F, G	<a href="#">DAS-108</a>
C1B56	86	SONAR CIRCUIT	G	<a href="#">DAS-109</a>
C1B57	87	AVM CIRCUIT	G	<a href="#">DAS-110</a>
C1B59	184	CCM CIRCUIT	A, B, C, F, G	<a href="#">DAS-111</a>
C1B82	12	DIST SEN OFF-CENTER	A, C, D, E	<a href="#">DAS-112</a>
C1B84	17	DIST SEN MALFUNCTION	A, C, D, E	<a href="#">DAS-113</a>
C1B85	21	DIST SEN ABNORMAL TEMP	A, C, D, E	<a href="#">DAS-114</a>
C1B86	80	DIST SEN PWR SUP CIR	A, C, D, E	<a href="#">DAS-115</a>
C1F01	91	APA MOTOR MALF	A, C, D, E	<a href="#">DAS-117</a>
C1F02	92	APA C/U MALF	A, C, D, E	<a href="#">DAS-118</a>

# ADAS CONTROL UNIT

< ECU DIAGNOSIS INFORMATION >

[ICC]

Systems for fail-safe

- A: Vehicle-to-vehicle distance control mode
- B: Conventional (fixed speed) cruise control mode
- C: Distance Control Assist (DCA)
- D: Forward Emergency Braking (FEB)
- E: Predictive Forward Collision Warning (PFCW)
- F: Blind Spot Warning (BSW)
- G: Back-up Collision Intervention (BCI)

DTC		CONSULT display	Fail-safe	Reference
CONSULT	On board display		System	
C1F05	95	APA PWR SUPPLY CIR	A, C, D, E	<a href="#">DAS-119</a>
U0121	127	VDC CAN CIR 2	A, B, C, D, E, F, G	<a href="#">DAS-120</a>
U0126	130	STRG SEN CAN CIR 1	A, B, C, D, E, F, G	<a href="#">DAS-121</a>
U0235	144	ICC SENSOR CAN CIRC 1	A, C, D, E	<a href="#">DAS-122</a>
U0401	120	ECM CAN CIR 1	A, B, C, D, E, F, G	<a href="#">DAS-123</a>
U0402	122	TCM CAN CIR 1	A, B, C, D, E, F, G	<a href="#">DAS-124</a>
U0415	126	VDC CAN CIR 1	A, B, C, D, E, F, G	<a href="#">DAS-125</a>
U0424	156	HVAC CAN CIR 1		<a href="#">DAS-126</a>
U0428	131	STRG SEN CAN CIR 2	A, B, C, D, E, F, G	<a href="#">DAS-127</a>
U1000 <sup>NOTE</sup>	100	CAN COMM CIRCUIT	A, B, C, D, E, F, G	<a href="#">DAS-128</a>
U1010	110	CONTROL UNIT (CAN)	A, B, C, D, E, F, G	<a href="#">DAS-130</a>
U150B	157	ECM CAN CIRC 3	A, B, C, D, E, F, G	<a href="#">DAS-131</a>
U150C	158	VDC CAN CIRC 3	A, B, C, D, E, F, G	<a href="#">DAS-132</a>
U150D	159	TCM CAN CIRC 3	A, B, C, D, E, F, G	<a href="#">DAS-133</a>
U150E	160	BCM CAN CIRC 3	A, B, C, D, F, G	<a href="#">DAS-134</a>
U150F	161	AV CAN CIRC 3		<a href="#">DAS-135</a>
U1502	147	ICC SEN CAN COMM CIR	A, C, D, E	<a href="#">DAS-136</a>
U1503	150	SIDE RDR L CAN CIR 2	F, G	<a href="#">DAS-137</a>
U1504	151	SIDE RDR L CAN CIR 1	F, G	<a href="#">DAS-138</a>
U1505	152	SIDE RDR R CAN CIR 2	F, G	<a href="#">DAS-139</a>
U1506	153	SIDE RDR R CAN CIR 1	F, G	<a href="#">DAS-140</a>
U1507	154	LOST COMM (SIDE RDR R)	F, G	<a href="#">DAS-141</a>
U1508	155	LOST COMM (SIDE RDR L)	F, G	<a href="#">DAS-142</a>
U1512	162	HVAC CAN CIRC3		<a href="#">DAS-143</a>
U1513	163	METER CAN CIRC 3	A, B, C, D, E, F, G	<a href="#">DAS-144</a>
U1514	164	STRG SEN CAN CIRC 3	A, B, C, D, E, F, G	<a href="#">DAS-145</a>
U1515	165	ICC SENSOR CAN CIRC 3	A, C, D, E	<a href="#">DAS-146</a>
U1517	167	APA CAN CIRC 3	A, C, D, E	<a href="#">DAS-147</a>
U1518	168	SIDE RDR L CAN CIRC 3	F, G	<a href="#">DAS-148</a>
U1519	169	SIDE RDR R CAN CIRC 3	F, G	<a href="#">DAS-149</a>
U1521	177	SONAR CAN COMMUNICATION 2	G	<a href="#">DAS-150</a>
U1522	178	SONAR CAN COMMUNICATION 1	G	<a href="#">DAS-151</a>
U1523	179	SONAR CAN COMMUNICATION 3	G	<a href="#">DAS-152</a>
U1524	180	AVM CAN COMMUNICATION 1	G	<a href="#">DAS-153</a>
U1525	181	AVM CAN COMMUNICATION 3	G	<a href="#">DAS-154</a>
U1527	185	CCM CAN CIR1	A, B, C, F, G	<a href="#">DAS-155</a>
U153F	186	CCM CAN CIR2	A, B, C, F, G	<a href="#">DAS-156</a>

# ADAS CONTROL UNIT

< ECU DIAGNOSIS INFORMATION >

[ICC]

Systems for fail-safe

- A: Vehicle-to-vehicle distance control mode
- B: Conventional (fixed speed) cruise control mode
- C: Distance Control Assist (DCA)
- D: Forward Emergency Braking (FEB)
- E: Predictive Forward Collision Warning (PFCW)
- F: Blind Spot Warning (BSW)
- G: Back-up Collision Intervention (BCI)

DTC		CONSULT display	Fail-safe	Reference
CONSULT	On board display		System	
U1530	183	DR ASSIST BUZZER CAN CIR1		<a href="#">DAS-157</a>
U1540	200	DAST CAN CIR 1	C, D, E	<a href="#">DAS-158</a>
U1541	201	DAST CAN CIR 2	C, D, E	<a href="#">DAS-159</a>

**NOTE:**

With the detection of “U1000” some systems do not perform the fail-safe operation.

A system controlling based on a signal received from the control unit performs fail-safe operation when the communication with the ADAS control unit becomes inoperable.

A  
B  
C  
D  
E  
F  
G  
H  
I  
J  
K  
L  
M  
N  
P



# ICC SENSOR

< ECU DIAGNOSIS INFORMATION >

[ICC]

## ICC SENSOR

### Reference Value

INFOID:000000009644225

### VALUES ON THE DIAGNOSIS TOOL

**NOTE:**

The following table includes information (items) inapplicable to this vehicle. For information (items) applicable to this vehicle, refer to CONSULT display items.

Monitor item	Condition		Value/Status
VHCL SPEED SE	While driving		Value of vehicle speed signal (wheel speed)
YAW RATE	While driving	Vehicle stopped	0.0
		Vehicle turning right	Positive value
		Vehicle turning left	Negative value
PWR SUP MONI	Ignition switch ON		Power supply voltage value of ICC sensor
DISTANCE	Drive the vehicle and activate the vehicle-to-vehicle distance control mode	When a vehicle ahead is detected	Displays the distance from the preceding vehicle
		When a vehicle ahead is not detected	0.0
RELATIVE SPD	Drive the vehicle and activate the vehicle-to-vehicle distance control mode	When a vehicle ahead is detected	Displays the relative speed
		When a vehicle ahead is not detected	0.0
RADAR OFFSET	<b>NOTE:</b> The item is indicated, but not used		—
RADAR HEIGHT	<b>NOTE:</b> The item is indicated, but not used		—
STEERING ANGLE	Ignition switch ON	When setting the steering wheel in straight-ahead position	0.0
		When turning the steering wheel 90° rightward	+90
		When turning the steering wheel 90° leftward	-90
STRG ANGLE SPEED	Ignition switch ON	At the time of turning the steering wheel	Steering wheel turning speed is displayed
L/R ADJUST	Ignition switch ON	At the completion of radar alignment adjustment	Horizontal correction value is displayed
U/D ADJUST	Ignition switch ON	At the completion of radar alignment adjustment	Vertical correction value is displayed

### TERMINAL LAYOUT

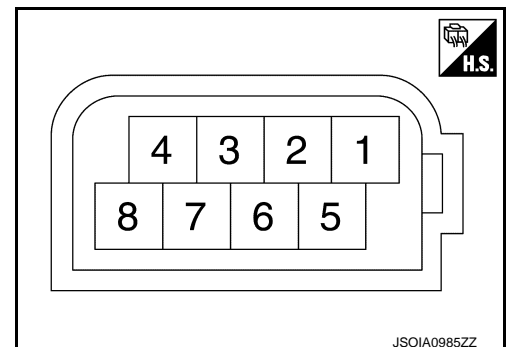

## PHYSICAL VALUES

Terminal No. (Wire color)		Description		Condition	Standard value	Reference value
+	-	Signal name	Input/ Output			
1 (R)	Ground	Ignition power supply	Input	Ignition switch ON	10 - 16 V	Battery voltage
3 (L)		ITS communication-H	—	—	—	—
6 (Y)		ITS communication-L	—	—	—	—
8 (B)		Ground	—	Ignition switch ON	0 - 0.1 V	Approx. 0 V

### Fail-safe (ICC Sensor)

INFOID:000000009644226

If a malfunction occurs in the ICC sensor, ADAS control unit cancels control, sounds a beep, and turns ON the ICC system warning in the information display.

### DTC Inspection Priority Chart

INFOID:000000009644227

If multiple DTCs are detected simultaneously, check them one by one depending on the following DTC inspection priority chart.

Priority	Detected items (DTC)
1	<ul style="list-style-type: none"> <li>• U1000: CAN COMM CIRCUIT</li> <li>• U1010: CONTROL UNIT (CAN)</li> </ul>
2	<ul style="list-style-type: none"> <li>• C1A50: ADAS MALFUNCTION</li> </ul>
3	<ul style="list-style-type: none"> <li>• C1A01: POWER SUPPLY CIR</li> <li>• C1A02: POWER SUPPLY CIR 2</li> <li>• C1A12: RADAR OFF-CENTER</li> <li>• C1A16: RADAR BLOCKED</li> <li>• C1A21: UNIT HIGH TEMP</li> <li>• C1A23: UNIT LOW TEMP</li> <li>• C1A39: STRG SEN CIR</li> <li>• U0104: ADAS CAN CIR1</li> <li>• U0121: VDC CAN CIR2</li> <li>• U0126: STRG SEN CAN CIR1</li> <li>• U0405: ADAS CAN CIR2</li> <li>• U0415: VDC CAN CIR1</li> <li>• U0428: STRG SEN CAN CIR2</li> </ul>
4	<ul style="list-style-type: none"> <li>• C1A00: CONTROL UNIT</li> </ul>

### DTC Index

INFOID:000000009644228

#### NOTE:

- The details of time display are as per the following.
- 0: The malfunctions that are detected now  
CAN communication system (U1000, U1010)
- 1 - 39: It increases like 0 → 1 → 2 ... 38 → 39 after returning to the normal condition whenever the ignition switch OFF → ON. It returns to 0 when a malfunction is detected again in the process.
- If it is over 39, it is fixed to 39 until the self-diagnosis results are erased.  
Other than CAN communication system (Other than U1000, U1010)
- 1 - 49: It increases like 0 → 1 → 2 ... 38 → 49 after returning to the normal condition whenever the ignition switch OFF → ON. It returns to 0 when a malfunction is detected again in the process.
- If it is over 49, it is fixed to 49 until the self-diagnosis results are erased.

×: Applicable



# ICC SENSOR

< ECU DIAGNOSIS INFORMATION >

[ICC]

DTC	CONSULT display	Fail-safe				Reference
		Vehicle-to-vehicle distance control mode	Conventional (fixed speed) cruise control mode	Distance Control Assist (DCA)	Forward Emergency Braking (FEB) / Predictive Forward Collision Warning (PFCW)	
C1A00	CONTROL UNIT	×	×	×	×	<a href="#">CCS-101</a>
C1A01	POWER SUPPLY CIR	×	×	×	×	<a href="#">CCS-102</a>
C1A02	POWER SUPPLY CIR2	×	×	×	×	<a href="#">CCS-102</a>
C1A12	RADAR OFF-CENTER	×		×	×	<a href="#">CCS-103</a>
C1A16	RADAR BLOCKED	×		×	×	<a href="#">CCS-104</a>
C1A21	UNIT HIGH TEMP	×	×	×	×	<a href="#">CCS-106</a>
C1A23	UNIT LOW TEMP	×	×	×	×	<a href="#">CCS-107</a>
C1A39	STRG SEN CIR	×	×	×	×	<a href="#">CCS-108</a>
C1A50	ADAS MALFUNCTION	×	×	×	×	<a href="#">CCS-109</a>
U0104	ADAS CAN CIR1	×	×	×	×	<a href="#">CCS-110</a>
U0121	VDC CAN CIR2	×	×	×	×	<a href="#">CCS-111</a>
U0126	STRG SEN CAN CIR1	×	×	×	×	<a href="#">CCS-112</a>
U0405	ADAS CAN CIR2	×	×	×	×	<a href="#">CCS-113</a>
U0415	VDC CAN CIR1	×	×	×	×	<a href="#">CCS-114</a>
U0428	STRG SEN CAN CIR2	×	×	×	×	<a href="#">CCS-115</a>
U1000	CAN COMM CIRCUIT	×	×	×	×	<a href="#">CCS-116</a>
U1010	CONTROL UNIT (CAN)	×	×	×	×	<a href="#">CCS-117</a>



# DRIVER ASSISTANCE BUZZER CONTROL MODULE

< ECU DIAGNOSIS INFORMATION >

[ICC]

## DRIVER ASSISTANCE BUZZER CONTROL MODULE

### Reference Value

INFOID:000000009759620

### VALUES ON THE DIAGNOSIS TOOL

#### NOTE:

The following table includes information (items) inapplicable to this vehicle. For information (items) applicable to this vehicle, refer to CONSULT display items.

Monitor item	Condition		Value/Status
Buzzer 1 request (ADAS)	Drive the vehicle and operate each system	Except for the LDW/LDP/Blind Spot Warning/Blind Spot Intervention warning condition	Off
		When the LDW warning condition	TYPE 1
		When the BSW warning condition	TYPE 2
		When the Blind Spot Intervention warning condition	TYPE 3
		When the warning condition cancel	Cancel
Buzzer 1 volume (ADAS)	Ignition switch ON	When the buzzer sound	It changes according to the sound volume of buzzer
Buzzer 1 stop (ADAS)	Ignition switch ON	When the buzzer cancel immediate	IMEDIAT
		When the buzzer cancel other than above	CYCLE
Buzzer 2 request (ADAS)	Drive the vehicle and operate each system	Except for the ICC/PFCW/DCA warning condition	Off
		When the approach warning condition	TYPE 1
		When the PFCW warning condition	TYPE 2
		When the DCA condition	TYPE 3
		When the warning condition cancel	Cancel
Buzzer 2 volume (ADAS)	Ignition switch ON	When the buzzer sound	It changes according to the sound volume of buzzer
Buzzer 2 stop (ADAS)	Ignition switch ON	When the buzzer cancel immediate	IMEDIAT
		When the buzzer cancel other than above	CYCLE
Buzzer 3 request (ADAS)	Drive the vehicle and operate each system	Except for the FEB warning condition	Off
		When the FEB warning condition	TYPE 1
		When the warning condition cancel	Cancel
Buzzer 3 volume (ADAS)	Ignition switch ON	When the buzzer sound	It changes according to the sound volume of buzzer
Buzzer 3 stop (ADAS)	Ignition switch ON	When the buzzer cancel immediate	IMEDIAT
		When the buzzer cancel other than above	CYCLE
Buzzer 4 request (ADAS)	Drive the vehicle and operate each system	Except for the PFCW warning condition	Off
		When the PFCW warning condition	TYPE 1
		When the warning condition cancel	Cancel
Buzzer 4 volume (ADAS)	Ignition switch ON	When the buzzer sound	It changes according to the sound volume of buzzer
Buzzer 4 stop (ADAS)	Ignition switch ON	When the buzzer cancel immediate	IMEDIAT
		When the buzzer cancel other than above	CYCLE

# DRIVER ASSISTANCE BUZZER CONTROL MODULE

< ECU DIAGNOSIS INFORMATION >

[ICC]

Monitor item	Condition		Value/Status
Buzzer 1 request (CCM)	Drive the vehicle and operate each system	Except for the LDW/LDP/Blind Spot Warning/Blind Spot Intervention warning condition	Off
		When the LDW warning condition	TYPE 1
		When the BSW warning condition	TYPE 2
		When the Blind Spot Intervention warning condition	TYPE 3
		When the warning condition cancel	Cancel
Buzzer 1 volume (CCM)	Ignition switch ON	When the buzzer sound	It changes according to the sound volume of buzzer
Buzzer 1 stop (CCM)	Ignition switch ON	When the buzzer cancel immediate	IMEDIAT
		When the buzzer cancel other than above	CYCLE
Buzzer 2 request (CCM)	Drive the vehicle and operate each system	Except for the ICC/PFCW/DCA warning condition	Off
		When the approach warning condition	TYPE 1
		When the PFCW warning condition	TYPE 2
		When the DCA condition	TYPE 3
		When the warning condition cancel	Cancel
Buzzer 2 volume (CCM)	Ignition switch ON	When the buzzer sound	It changes according to the sound volume of buzzer
Buzzer 2 stop (CCM)	Ignition switch ON	When the buzzer cancel immediate	IMEDIAT
		When the buzzer cancel other than above	CYCLE
Buzzer 3 request (CCM)	Drive the vehicle and operate each system	Except for the FEB warning condition	Off
		When the FEB warning condition	TYPE 1
		When the warning condition cancel	Cancel
Buzzer 3 volume (CCM)	Ignition switch ON	When the buzzer sound	It changes according to the sound volume of buzzer
Buzzer 3 stop (CCM)	Ignition switch ON	When the buzzer cancel immediate	IMEDIAT
		When the buzzer cancel other than above	CYCLE
Buzzer 4 request (CCM)	Drive the vehicle and operate each system	Except for the PFCW warning condition	Off
		When the PFCW warning condition	TYPE 1
		When the warning condition cancel	Cancel
Buzzer 4 volume (CCM)	Ignition switch ON	When the buzzer sound	It changes according to the sound volume of buzzer
Buzzer 4 stop (CCM)	Ignition switch ON	When the buzzer cancel immediate	IMEDIAT
		When the buzzer cancel other than above	CYCLE
ADAS MALFUNCTION	Ignition switch ON	When the ADAS control unit malfunction	On
		When the ADAS control unit normal	Off
CCM MALFUNCTION	Ignition switch ON	When the chassis control module malfunction	On
		When the chassis control module normal	Off
DR ASSIST BUZZ MALF	Ignition switch ON	When the driver assistance control module malfunction	On
		When the driver assistance control module normal	Off

# DRIVER ASSISTANCE BUZZER CONTROL MODULE

< ECU DIAGNOSIS INFORMATION >

[ICC]

Monitor item	Condition	Value/Status	
DR ASSIST BUZZ STATUS	Drive the vehicle and operate each system	Except for the warning condition	Off
		LDW/LDP//Blind Spot Warning/Blind Spot Intervention system warning in progress	1
		ICC/PFCW/DCA system warning in progress	2
		FEB system warning in progress	3
		LDW/LDP//Blind Spot Warning/Blind Spot Intervention/ICC/PFCW/DCA system warning in progress	1, 2
		ICC/PFCW/DCA system warning in progress.	2, 4
		LDW/LDP//Blind Spot Warning/Blind Spot Intervention/PFCW system warning in progress	1, 4
		PFCW system	4

## TERMINAL LAYOUT

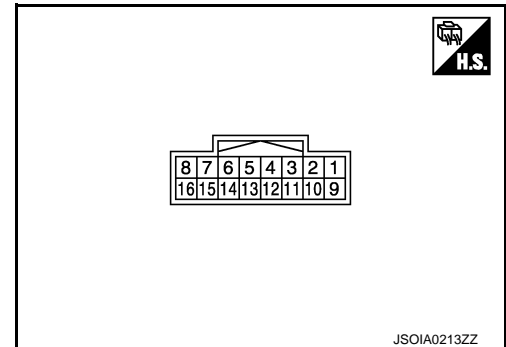

## PHYSICAL VALUES

Terminal No. (Wire color)		Description		Condition		Standard value	Reference value
+	-	Signal name	Input/Output				
1 (G)	5 (B)	Ignition power supply	Input	Ignition switch ON	—	10 - 16 V	Battery voltage
3 (L)	—	ITS communication-H	—	—	—		—
5 (B)	Ground	Ground	—	Ignition switch ON	—	0 - 0.1 V	Approx. 0 V

A  
B  
C  
D  
E  
F  
G  
H  
I  
J  
K  
L  
M  
N  
P

CCS

# DRIVER ASSISTANCE BUZZER CONTROL MODULE

< ECU DIAGNOSIS INFORMATION >

[ICC]

Terminal No. (Wire color)		Description		Condition	Standard value	Reference value	
+	-	Signal name	Input/Output				
8 (R)	16 (G)	Warning buzzer signal	Output	Ignition switch ON	Driver assistance buzzer OFF	0 - 0.1 V	Approx. 0 V
					At "BUZZER 1" test of "Active test"	<p style="text-align: right; font-size: small;">J50IA0949ZZ</p>	
					At "BUZZER 2" test of "Active test"	<p style="text-align: right; font-size: small;">J50IA0950ZZ</p>	
					At "BUZZER 3" test of "Active test"	<p style="text-align: right; font-size: small;">J50IA0951ZZ</p>	
11 (Y)	—	ITS communication-L	—	—	—	—	
13 (B)	Ground	Ground	—	Ignition switch ON	—	0 - 0.1 V	Approx. 0 V
16 (G)	5 (B)	Warning buzzer signal ground	Output	Ignition switch ON	—	0 - 0.1 V	Approx. 0 V

## DTC Inspection Priority Chart

INFOID:000000009759621

If multiple DTCs are detected simultaneously, check them one by one depending on the following DTC inspection priority chart.

Priority	Detected items (DTC)
1	<ul style="list-style-type: none"> <li>U1000: CAN COMM CIRCUIT</li> <li>U1010: CONTROL UNIT (CAN)</li> </ul>
2	<ul style="list-style-type: none"> <li>U0104: ADAS CAN CIR2</li> <li>U1527: CCM CAN CIRCUIT 1</li> </ul>
3	<ul style="list-style-type: none"> <li>C1B20: CONTROL MODULE</li> </ul>

## DTC Index

INFOID:000000009759622

### NOTE:

- The details of time display are as per the following.
- CRNT: A malfunction is detected now
- PAST: A malfunction was detected in the past
- IGN counter is displayed in FFD (Freeze Frame Data).
- 0: The malfunctions that are detected now

# DRIVER ASSISTANCE BUZZER CONTROL MODULE

[ICC]

## < ECU DIAGNOSIS INFORMATION >

- 1 - 39: It increases like 0 → 1 → 2 ... 38 → 39 after returning to the normal condition whenever the ignition switch OFF → ON. It returns to 0 when a malfunction is detected again in the process.
- If it is over 39, it is fixed to 39 until the self-diagnosis results are erased.

×: Applicable

DTC		Reference
C1B20	CONTROL MODULE	<a href="#">DAS-332</a>
U0104	ADAS CAN CIR2	<a href="#">DAS-348</a>
U1527	CCM CAN CIRCUIT 1	<a href="#">DAS-358</a>
U1000	CAN COMM CIRCUIT	<a href="#">DAS-353</a>
U1010	CONTROL UNIT (CAN)	<a href="#">DAS-356</a>

A  
B  
C  
D  
E  
F  
G  
H  
I  
J  
K  
L  
M  
N  
P

CCS

< WIRING DIAGRAM >

# WIRING DIAGRAM

## INTELLIGENT CRUISE CONTROL

Wiring Diagram

INFOID:000000009644229

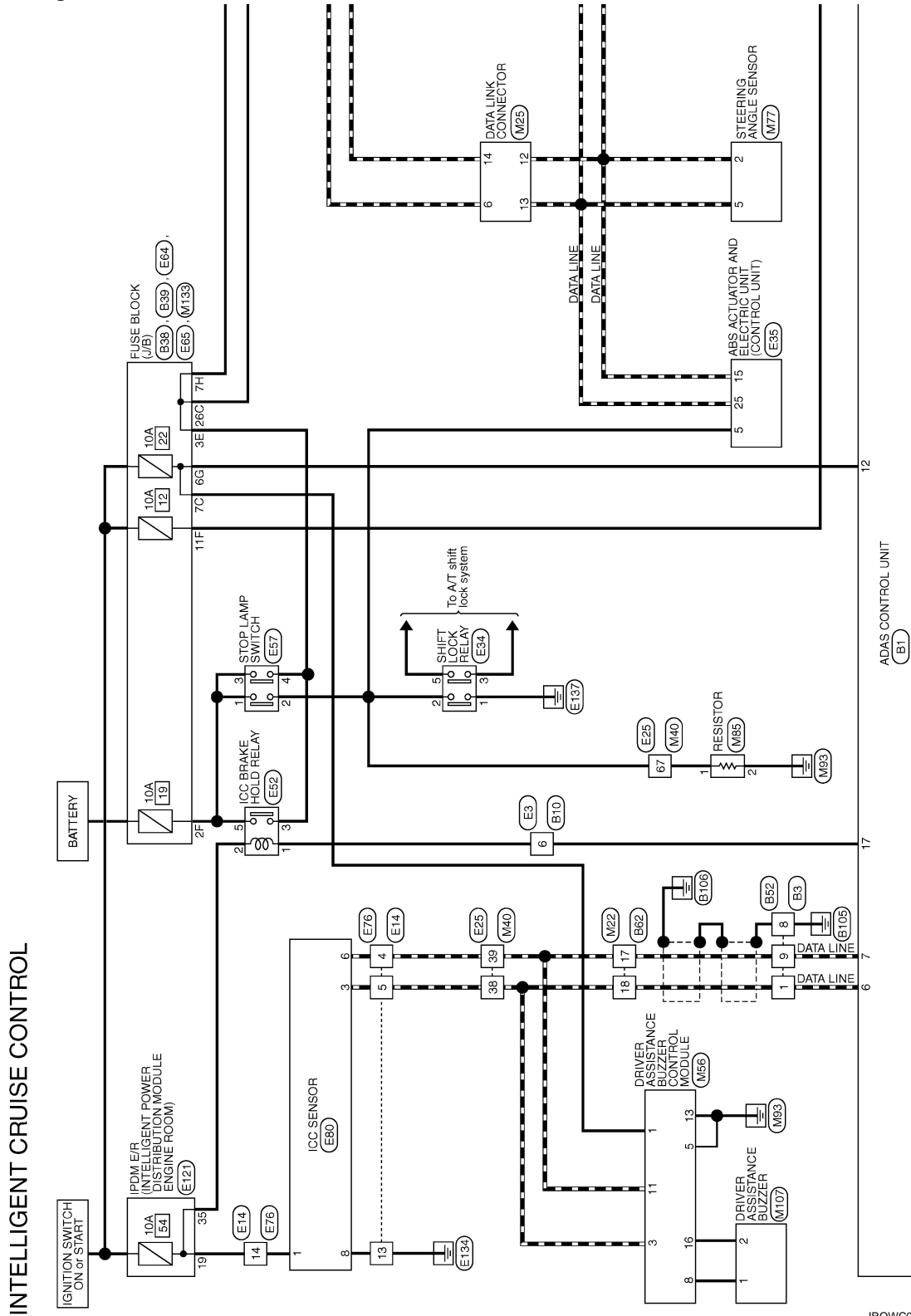

\*: This connector is not shown in "Harness Layout".

2013/05/17

JROWC0557GB



# INTELLIGENT CRUISE CONTROL

< WIRING DIAGRAM >

[ICC]

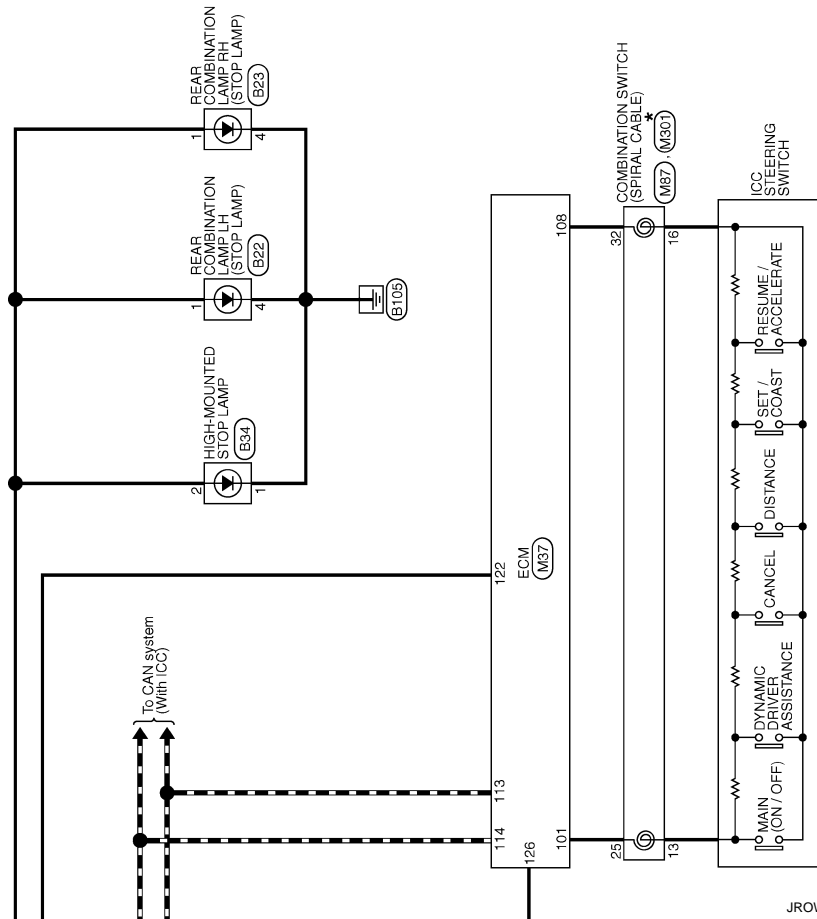

JROWC0559GB



# INTELLIGENT CRUISE CONTROL

< WIRING DIAGRAM >

[ICC]

## INTELLIGENT CRUISE CONTROL

Connector No.	B1
Connector Name	ADAS CONTROL UNIT
Connector Type	TH24FW-NH

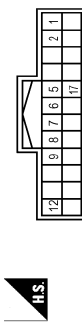

Terminal No.	Color Of Wire	Signal Name [Specification]
1	L	GM-H
2	R	GM-H
3	B	GROUND
4	B	ITS COMM-H
7	P	ITS COMM-L
8	L	CHASSIS COMM-H
9	V	CHASSIS COMM-L
12	GR	IGNITION
17	V	BRAKE HOLD RLY DRIVE SIGNAL

Connector No.	B3
Connector Name	WIRE TO WIRE
Connector Type	NS10PW-CS

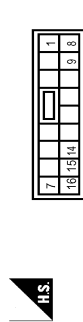

Terminal No.	Color Of Wire	Signal Name [Specification]
1	L	-
7	R	-
8	B	-
9	P	-
15	B	-
16	BR	-

Connector No.	B10
Connector Name	WIRE TO WIRE
Connector Type	TH24FW-NH

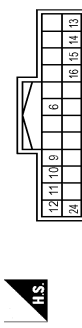

Terminal No.	Color Of Wire	Signal Name [Specification]
8	V	-
9	B	-
10	B	-
11	G	-
12	R	-
13	GR	-
14	BG	-
15	BR	-
16	LG	-
24	SHIELD	-

Connector No.	B22
Connector Name	REAR COMBINATION LAMP LH (BODY SIDE)
Connector Type	NS24MM-CS



Terminal No.	Color Of Wire	Signal Name [Specification]
1	LG	-
2	P	-
3	SB	-
4	B	-

Connector No.	B23
Connector Name	REAR COMBINATION LAMP RH (BODY SIDE)
Connector Type	NS24MM-CS



Terminal No.	Color Of Wire	Signal Name [Specification]
1	LG	-
2	V	-
3	Y	-
4	B	-

Connector No.	B24
Connector Name	HIGH-MOUNTED STOP LAMP
Connector Type	TK02MBR-P



Terminal No.	Color Of Wire	Signal Name [Specification]
1	B	-
2	LG	-

Connector No.	B38
Connector Name	FUSE BLOCK (J B)
Connector Type	NS10PW-CS

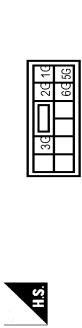

Terminal No.	Color Of Wire	Signal Name [Specification]
1	GR	-
2	GR	-
3	GR	-
4	BR	-
5	W	-
6	G	-

Connector No.	B39
Connector Name	FUSE BLOCK (J B)
Connector Type	TH10PE-NH



Terminal No.	Color Of Wire	Signal Name [Specification]
10H	P	-
3H	L	-
4H	R	-
6H	L	-
7H	LG	-
8H	P	-

A  
B  
C  
D  
E  
F  
G  
H  
I  
J  
K  
L  
M  
N  
P

CCS

JROWC0560GB

# INTELLIGENT CRUISE CONTROL

< WIRING DIAGRAM >

[ICC]

## INTELLIGENT CRUISE CONTROL

Connector No.	E22
Connector Name	WIRE TO WIRE
Connector Type	NSI(BMW)-CS



Terminal No.	Color Of Wire	Signal Name [Specification]
1	B	
2	B	
3	SHIELD	
4	P	
5	W	
6	W	
7	W	
8	BR	
9	W	
10	W	
11	W	
12	W	
13	W	
14	W	
15	W	
16	BR	

Connector No.	EB2
Connector Name	WIRE TO WIRE
Connector Type	TH88PW-CSE-TMA



Terminal No.	Color Of Wire	Signal Name [Specification]
1	R	
2	L	
3	R	- [With BOSE system]
4	W	- [Without BOSE system]
5	SHIELD	
6	G	
7	BR	
8	W	- [Without BOSE system]
9	W	- [With BOSE system]
10	W	- [Without BOSE system]

11	GR	
12	Y	
13	R	
14	BG	
15	GR	
16	V	
17	P	
18	L	
19	R	
20	GR	
21	R	
22	P	
23	W	
24	W	
25	GB	
26	P	
27	LG	
28	R	
29	R	
30	LG	
31	R	
32	R	
33	W	
34	W	
35	W	
36	W	
37	R	
38	W	
39	W	
40	G	
41	SHIELD	
42	G	
43	BG	
44	G	
45	G	
46	R	
47	GR	
48	GR	
49	R	
50	P	
51	LG	
52	P	
53	L	
54	W	
55	LG	
56	L	
57	W	
58	W	
59	W	
60	W	
61	W	
62	W	
63	W	
64	W	
65	L	
66	LG	
67	P	
68	L	
69	P	
70	R	
71	R	
72	G	
73	SHIELD	
74	BR	
75	BR	
76	BG	
77	BG	
78	W	
79	LG	
80	LG	
81	V	
82	V	
83	V	
84	V	
85	V	
86	V	
87	V	
88	V	
89	V	
90	V	
91	V	
92	V	

Terminal No.	Color Of Wire	Signal Name [Specification]
83	R	
84	R	
85	Y	
86	W	
87	L	
88	BR	
89	BR	
90	BR	
91	BR	
92	BR	

Connector No.	E3
Connector Name	WIRE TO WIRE
Connector Type	TH24MW-NH



Terminal No.	Color Of Wire	Signal Name [Specification]
6	Y	
9	W	
10	B	
11	G	
12	R	
13	GR	
14	C	
15	V	
16	Y	
24	SHIELD	

Connector No.	E14
Connector Name	WIRE TO WIRE
Connector Type	SAA18MB-RS10-SJZZ

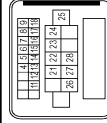

Terminal No.	Color Of Wire	Signal Name [Specification]
4	Y	
5	L	
6	B	
7	BR	
8	LG	
9	W	
10	V	
11	V	
12	R	
13	B	
14	P	
15	GR	
16	V	
17	B	
18	B	
19	B	
20	B	
21	B	
22	SHIELD	
23	P	
24	L	
25	V	
26	B	
27	B	
28	B	

Connector No.	E25
Connector Name	WIRE TO WIRE
Connector Type	TH88PW-CSE-TMA

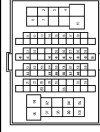

Terminal No.	Color Of Wire	Signal Name [Specification]
2	W	
3	LG	
4	BR	
5	Y	
6	Y	
7	Y	
8	Y	
9	BR	
10	BR	
11	L	
12	GR	
13	W	
14	B	

# INTELLIGENT CRUISE CONTROL

< WIRING DIAGRAM >

[ICC]

**INTELLIGENT CRUISE CONTROL**

15	SP	-
16	BR	-
17	BR	-
18	P	-
19	SHIELD	-
20	Y	-
32	GR	-
35	GR	-
36	R	-
37	V	-
38	L	-
39	Y	-
40	SB	-
41	LG	-
44	Y	-
45	W	-
46	B	-
47	B	-
48	SHIELD	-
49	R	-
50	BR	-
51	L	-
52	W	-
53	V	-
54	P	-
55	W	-
56	SB	-
57	BG	-
58	B	-
59	W	-
60	Y	-
61	Y	-
64	Y	-
65	SB	-
66	GR	-
67	LG	-
68	BG	-
71	LG	-
72	V	-
73	G	-
74	BR	-
75	V	-
78	P	-
79	SB	-
80	EG	-
81	EG	-
82	Y	-
84	GR	-
85	BG	-
86	W	-
96	W	-
97	LG	-

98	L	-
99	P	-
100	SHIELD	-

Connector No.	E54
Connector Name	SHIFT LOCK RELAY
Connector Type	MS02FL-MZ-LC

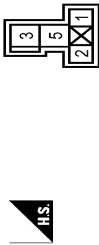

Terminal No.	Wire	Signal Name [Specification]
1	B	-
2	LG	-
3	GR	-
5	G	-

Connector No.	E55
Connector Name	ABS ACTUATOR AND ELECTRIC UNIT (COX) (HOLD UNIT)
Connector Type	SZ23PEP-SZ4-L

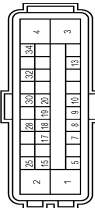

Terminal No.	Color Of Wire	Signal Name [Specification]
1	B	GROUND
2	B	GROUND
3	G	VALVE BATTERY
4	G	MOTOR BATTERY
5	LG	STOP LAMP SW SIGNAL (WITH ICC)
6	V	STOP LAMP SW SIGNAL (WITH ASCD)
7	GR	RR LH WHEEL SENSOR SIGNAL
8	G	FR LH WHEEL SENSOR POWER SUPPLY
9	BR	FR RH WHEEL SENSOR SIGNAL
10	GR	FR RH WHEEL SENSOR POWER SUPPLY
13	R	VACUUM SENSOR SIGNAL

15	P	CAH-L [Without Gateway]
17	V	RR RH WHEEL SENSOR SIGNAL
18	V	RR RH WHEEL SENSOR POWER SUPPLY
19	SB	FR LH WHEEL SENSOR SIGNAL
20	BG	FR LH WHEEL SENSOR POWER SUPPLY
25	L	CAH-H
28	G	VACUUM SENSOR POWER SUPPLY
30	R	VDC OFF SW SIGNAL
32	SHIELD	VACUUM SENSOR GROUND
34	G	IGN

Connector No.	E44
Connector Name	BRAKE PEDAL POSITION SWITCH
Connector Type	SG2FL



Terminal No.	Color Of Wire	Signal Name [Specification]
1	G	-
2	BG	-

Connector No.	E52
Connector Name	ICC BRAKE HOLD RELAY
Connector Type	MS02FL-MZ-LC



Terminal No.	Color Of Wire	Signal Name [Specification]
1	Y	-
2	G	-
3	V	-
5	L	-

Connector No.	E57
Connector Name	STOP LAMP SWITCH
Connector Type	M04FW-LC



Terminal No.	Color Of Wire	Signal Name [Specification]
1	G	- [With ASCD]
2	GR	- [With ASCD]
3	LG	- [With ICC]
4	V	-

Connector No.	E64
Connector Name	FUSE BLOCK (J/B)
Connector Type	NS06FW-CS



Terminal No.	Color Of Wire	Signal Name [Specification]
2E	P	-
3E	V	-
4E	GR	-
6E	L	-

A  
B  
C  
D  
E  
F  
G  
H  
I  
J  
K  
L  
M  
N  
P

# INTELLIGENT CRUISE CONTROL

## INTELLIGENT CRUISE CONTROL

Connector No.	E85
Connector Name	FUSE BLOCK (J/B)
Connector Type	TH12FW-NH

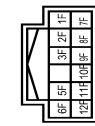

Terminal No.	Color Of Wire	Signal Name [Specification]
1F	W	
2F	G	
3F	BR	
4F	P	
5F	P	
6F	L	
7F	R	
8F	L	
9F	L	

Connector No.	E78
Connector Name	WIRE TO WIRE
Connector Type	SAA18FB-BS,DS-SL2Z

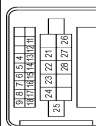

Terminal No.	Color Of Wire	Signal Name [Specification]
4	Y	
5	B	
6	B	
7	V	
8	LG	
9	GR	
11	LG	
12	BG	
13	B	

14	R	
15	G	
16	V	
17	B	
18	P	
21	B	
22	SHIELD	
23	P	
24	L	
25	V	
26	B	
27	B	
28	B	

Connector No.	E60
Connector Name	ECU SENSOR
Connector Type	AAZ08FB

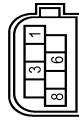

Terminal No.	Color Of Wire	Signal Name [Specification]
1	R	IGNITION
3	L	ITS COMM-H
6	Y	ITS COMM-L
8	B	GROUND

Connector No.	E121
Connector Name	FROM ICR INTELLIGENT POWER DISTRIBUTION MODULE ENGINE ROOM
Connector Type	TH32FW-NH



Terminal No.	Color Of Wire	Signal Name [Specification]
19	G	
22	BG	
23	LG	
27	GR	
28	P	
29	L	
31	G	
33	SB	
34	Y	
35	G	
36	SB	
37	GR	
38	SB	
43	Y	

Connector No.	F2
Connector Name	A/T ASSEMBLY
Connector Type	RK0FG-DGY



Terminal No.	Color Of Wire	Signal Name [Specification]
1	GR	IGNITION POWER SUPPLY
2	P	BATTERY POWER SUPPLY MEMORY BACK-UP
3	L	CAN-H
4	LG	K-LINE
5	B	GROUND
6	GR	IGNITION POWER SUPPLY
7	BG	BACK-UP LAMP RELAY
8	P	CAN-L
9	GR	STARTER RELAY
10	B	GROUND

Connector No.	F00
Connector Name	TCM(TRANSMISSION CONTROL MODULE)
Connector Type	SF0FG



Terminal No.	Color Of Wire	Signal Name [Specification]
1	W	IGNITION POWER SUPPLY
2	W	BATTERY POWER SUPPLY MEMORY BACK-UP
3	W	CAN-H
4	W	K-LINE
5	W	GROUND
6	W	IGNITION POWER SUPPLY
7	W	BACK-UP LAMP RELAY
8	W	CAN-L
9	W	STARTER RELAY
10	W	GROUND

Connector No.	M14
Connector Name	BOM (BODY CONTROL MODULE)
Connector Type	TH46FB-NH



Terminal No.	Color Of Wire	Signal Name [Specification]
48	R	PUSH-BTN IGN SW LLE PWR
52	G	DONGLE LINK
53	V	DOOR SW
54	G	RAIN SENSOR
59	P	CAN-L
60	L	CAN-H
61	G	REAR WINDOW DEF RLY CONT
62	R	STARTER RLY CONT
64	V	L-KEY WARN BUZZER
65	B	OUTSIDE LAMP CONT

# INTELLIGENT CRUISE CONTROL

< WIRING DIAGRAM >

[ICC]

## INTELLIGENT CRUISE CONTROL

86	B	BLOWER PANEL CONT
87	W	IGN RELAY (R) CONT
88	W	IGN RELAY (L) CONT
89	GR	A/T SHIF SELECT PWR SELY
90	GR	IGN RELAY (R) (M) (E) (R) CONT
70	B	DR DOOR REG SW
71	G	PASS DOOR REG SW
72	SB	COMBI SW INPUT 5
75	BR	COMBI SW INPUT 4
76	BG	COMBI SW INPUT 3
77	V	COMBI SW INPUT 2
78	Y	COMBI SW INPUT 1
79	LG	TR LID OPNR SW
80	L	

Connector No.	M22
Connector Name	WIRE TO WIRE
Connector Type	TH88MM-C516-TM4



H.S.

Terminal No.	Color Of Wire	Signal Name [Specification]
1	LG	
2	GR	
3	R	
4	SHIELD	
5	G	
6	BG	
7	LG	
8	P	
9	SHIELD	
10	V	
11	GR	
12	V	
13	LG	
14	GR	
15	SB	
16	V	[With DCM]
17	Y	[Without DCM]
18	L	
19	G	
20	GR	

21	R	
22	V	
23	L	
24	V	
25	LG	
26	GR	
29	SB	
30	LG	
36	R	
37	R	
38	W	
39	V	
45	G	
46	SHIELD	
47	G	
48	GR	
49	SB	
52	Y	
53	R	
54	GR	
57	R	
58	SB	
59	LG	
62	V	
63	L	
64	W	
66	R	
68	L	
69	P	
72	C	
73	SHIELD	
76	V	
84	BR	
85	BR	
86	V	
87	LG	
89	BR	
90	V	
92	W	
93	R	
94	R	
95	W	
97	W	
98	BR	
99	BR	
100	BR	

Connector No.	M24
Connector Name	CAN GATEWAY
Connector Type	TH127W-8H

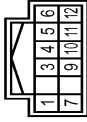

H.S.

Terminal No.	Color Of Wire	Signal Name [Specification]
1	L	CAN-H
2	V	CAN-B
3	B	CAN-RT
5	B	GND
6	L	CAN-H
7	P	CAN-L
9	R	IGN
10	R	CAN-L
11	B	GND
12	R	CAN-L

Connector No.	M25
Connector Name	DATA LINK CONNECTOR
Connector Type	BD16FW

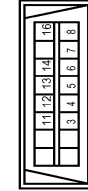

H.S.

Terminal No.	Color Of Wire	Signal Name [Specification]
3	SB	AV COMM(L)
4	B	EARTH
5	B	EARTH
6	V	IGN SW
7	V	IGN SW
8	W	IGN SW
11	LG	AV COMM(H)
12	R	CAN-L
13	L	CAN-H
14	P	CAN-L

Connector No.	M37
Connector Name	ECM
Connector Type	RH24CG-R2R-R4H-Z



H.S.

Terminal No.	Color Of Wire	Signal Name [Specification]
87	Y	ACCELERATOR PEDAL POSITION SENSOR 1
88	BR	ACCELERATOR PEDAL POSITION SENSOR 2
89	W	SENSOR POWER SUPPLY (ACCELERATOR PEDAL POSITION SENSOR 1)
100	G	SENSOR GROUND (ACCELERATOR PEDAL POSITION SENSOR 1)
101	SB	ASC2 STEERING SWITCH
101	SB	ICC STEERING SWITCH
102	LG	EVAP CONTROL SYSTEM PRESSURE SENSOR
103	L	SENSOR POWER SUPPLY (ACCELERATOR PEDAL POSITION SENSOR 2)
104	R	SENSOR GROUND (ACCELERATOR PEDAL POSITION SENSOR 2)
105	L	REFRIGERANT PRESSURE SENSOR
106	P	FUEL TANK TEMPERATURE SENSOR
107	GR	SENSOR POWER SUPPLY (ASC2 STEERING SWITCH)
108	BR	TRANSMISSION RANGE SWITCH
110	V	ENGINE SPEED SIGNAL OUTPUT
112	V	SIMBA PREPRES/FETRES
113	P	CAN COMMUNICATION LINE
114	L	CAN COMMUNICATION LINE
117	V	DATA LINK CONNECTOR
121	LG	EVAP CANISTER VENT CONTROL VALVE
122	SB	STOP LAMP SWITCH
123	B	ECM GROUND
124	B	ECM GROUND
125	R	POWER SUPPLY FOR ECM
126	BG	BRAKE PEDAL POSITION SWITCH
127	B	ECM GROUND
128	B	ECM GROUND

16	W	POWER
----	---	-------

A B C D E F G H I J K L M N P

CCS

JROWC0564GB

# INTELLIGENT CRUISE CONTROL

[ICC]

< WIRING DIAGRAM >

**INTELLIGENT CRUISE CONTROL**

Connector No.	M86
Connector Name	WIRE TO WIRE
Connector Type	TH188FW-CSI6-TM4



Terminal No.	Color Of Wire	Signal Name [Specification]
1	GR	
2	GR	
3	V	
4	V	
5	V	
6	W/B	
7	V	
8	W	
9	W	
10	W	
11	W	
12	B	
13	GR	
14	B	
15	SB	
16	B	
17	LG	
18	B	
19	V	
20	V	
21	V	
22	V	
23	RG	
24	G	
25	G	
26	L	
27	L	
28	Y	
29	Y	
30	GR	
31	L	
32	W	
33	W	
34	W	
35	G	
36	G	
37	G	
38	L	
39	Y	
40	GR	
41	L	
42	BR	
43	W	
44	W	
45	W	
46	G	
47	R	
48	SHIELD	
49	B	
50	BR	
51	BR	
52	W	
53	G	
54	Y	
55	P	
56	EG	

Connector No.	M85
Connector Name	RESISTOR
Connector Type	M02FBR-LC



Terminal No.	Color Of Wire	Signal Name [Specification]
1	LG	
2	B	

Connector No.	M87
Connector Name	COMBINATION SWITCH SIGNAL CABLE
Connector Type	TK0BFCO-IV



Terminal No.	Color Of Wire	Signal Name [Specification]
23	P	
24	P	
25	SB	
31	W/B	
32	Y	
33	B	

Connector No.	M88
Connector Name	COMBINATION METER
Connector Type	TH12FW-NH

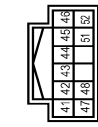

Terminal No.	Color Of Wire	Signal Name [Specification]
41	CAH-L	
42	CAH-L	
43	B	
44	Y	
45	W	
46	R	
47	LG	
48	SB	
51	BR	
52	B	

Connector No.	M77
Connector Name	STEERING ANGLE SENSOR
Connector Type	TH0BFW-NH

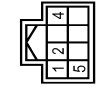

Terminal No.	Color Of Wire	Signal Name [Specification]
1	B	GROUND
2	P	CAH-L (Without Gateway)
3	C	CAH-L (With Gateway)
4	L	CAH-H

57	GR	
58	B	
59	SB	
60	W/B	
61	W/B	
62	Y	
63	R	
64	R	
65	R	
66	V	
67	LG	
68	EG	
69	V	
70	V	
71	V	
72	LG	
73	R	
74	BR	
75	B	
76	G	
77	G	
78	B	
79	B	
80	R	
81	R	
82	W	
83	R	
84	EG	
85	BR	
86	W	
87	LG	
88	Y	
89	BR	
90	SHIELD	

Connector No.	M89
Connector Name	DRIVER ASSISTANCE BUZZER CONTROL MODULE
Connector Type	TH188FW-NH

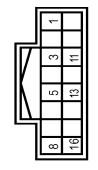

Terminal No.	Color Of Wire	Signal Name [Specification]
1	G	IGNITION
2	L	ITS COMM-H
3	B	GROUND
4	R	WARNING BUZZER SIGNAL
5	Y	ITS COMM-L
6	B	GROUND
7	G	WARNING BUZZER SIGNAL GROUND

JROWC0565GB

# INTELLIGENT CRUISE CONTROL

[ICC]

< WIRING DIAGRAM >

## INTELLIGENT CRUISE CONTROL

Connector No.	M83
Connector Name	A/C AUTO AMP.
Connector Type	TH48FW-NH

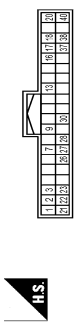

Terminal No.	Color Of Wire	Signal Name [Specification]
1	L	CAN-H
2	B	IGN
3	W	BAT
4	R	AMBIENT SENS
7	G	SUNLOAD SENS
8	R	IGN SW AGC
13	V	IGN SW AGC
16	P	LIN
17	R	DOOR MOTOR PWR SPLY
18	P	BLOWER MOTOR CONT
20	L	HEAT STRG WHIL RLY CONT
21	P	CAN-L
22	B	GND
23	W	IGN SW ON
26	B	SENS GND
27	G	IR-VEHICLE SENS
28	R	IR-VEHICLE SENS
30	EC	EXH GAS OUT COORDICT SENS
37	B	IONIZER CONT
38	BG	IONIZER CONT
40	BG	ECV CONT

## INTELLIGENT CRUISE CONTROL

Connector No.	M100
Connector Name	DISPLAY CONTROL UNIT
Connector Type	TH24FW-NH



Terminal No.	Color Of Wire	Signal Name [Specification]
16	SB	AV COMM (L)
17	R	EMERGE SIGNAL
18	R	REVERSE SIGNAL
22	B	GND
25	SB	CAMERA SWITCH SIGNAL
26	BR	AV COMM (H)
28	LG	CAN-H
29	L	CAN-H
30	R	IGN
31	R	VEHICLE SPEED SIGNAL (9-PULSE)
33	SB	ACC
34	Y	BAT

Connector No.	M107
Connector Name	DRIVER ASSISTANCE BUZZER
Connector Type	NS32FW-GS



Terminal No.	Color Of Wire	Signal Name [Specification]
1	G	
2	G	

## INTELLIGENT CRUISE CONTROL

Connector No.	M133
Connector Name	FUSE BLOCK (J/B)
Connector Type	TH48FW-NH



Terminal No.	Color Of Wire	Signal Name [Specification]
10C	V	
11C	Y	
12C	Y	
14C	Y	
16C	R	
17C	L	
18C	BG	- [Without DRPO]
18C	P	- [With DRPO]
19C	B	
20C	W	
21C	L	
22C	L	
23C	L	
24C	LG	
25C	LG	
26C	W	
28C	W	
29C	R	
30C	R	
31C	W	
32C	R	
33C	B	
34C	W/B	
35C	SB	
36C	R	
37C	W	
38C	SB	
39C	P	
40C	G	
41C	P	
42C	P	
43C	P	
44C	G	
45C	G	
46C	G	
47C	G	

## INTELLIGENT CRUISE CONTROL

Connector No.	V
Connector Name	
Connector Type	



Terminal No.	Color Of Wire	Signal Name [Specification]
13		
14		
15		
16		
17		
18		
19		
20		

A  
B  
C  
D  
E  
F  
G  
H  
I  
J  
K  
L  
M  
N  
P



JROWC0566GB

# DIAGNOSIS AND REPAIR WORK FLOW

[ICC]

< BASIC INSPECTION >

## BASIC INSPECTION

### DIAGNOSIS AND REPAIR WORK FLOW

Work Flow

INFOID:000000009644231

#### OVERALL SEQUENCE

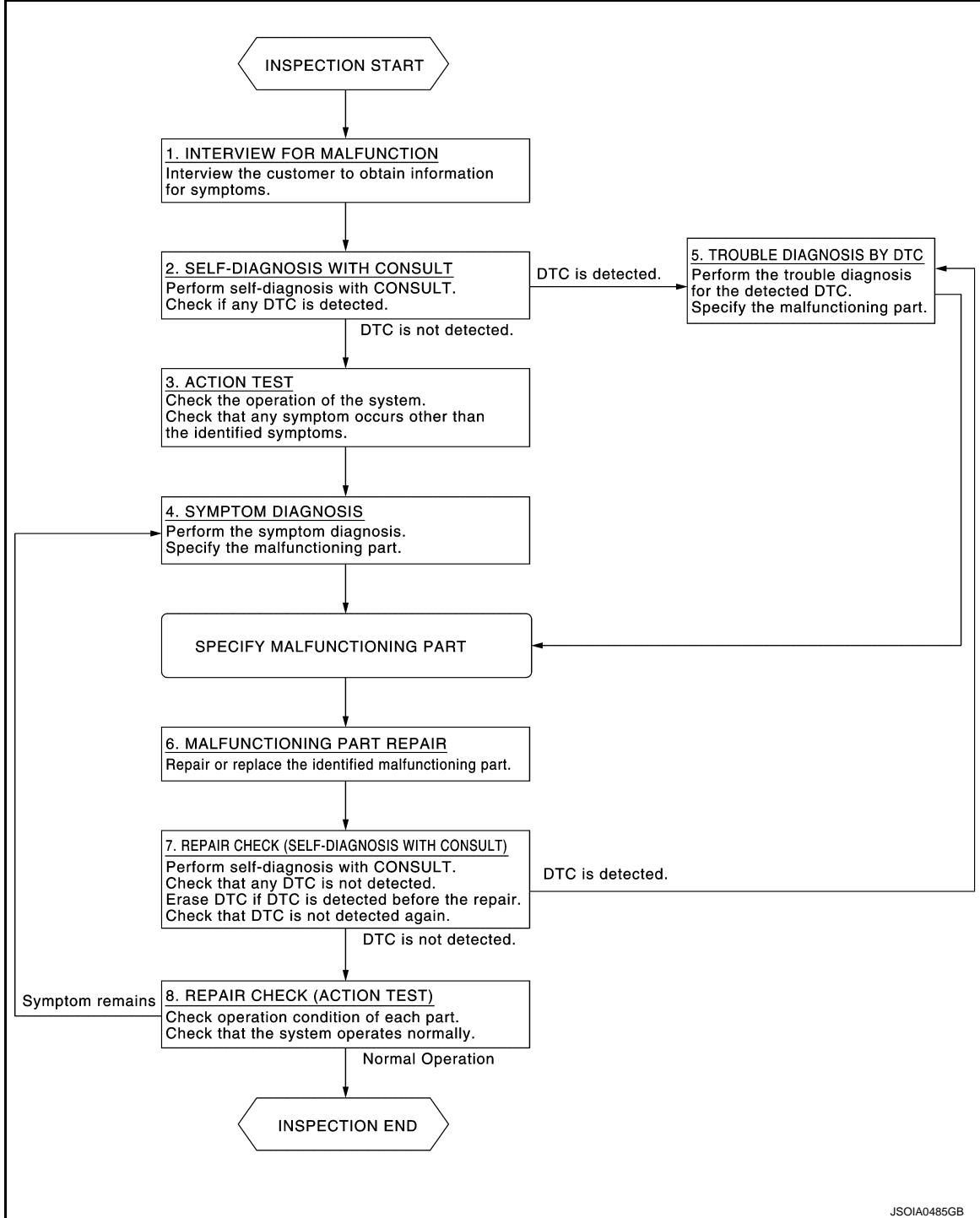

#### DETAILED FLOW

##### 1. INTERVIEW FOR MALFUNCTION

It is also important to clarify the customer concerns before starting the inspection. Interview the customer about the concerns carefully and understand the symptoms fully.

**NOTE:**



# DIAGNOSIS AND REPAIR WORK FLOW

[ICC]

## < BASIC INSPECTION >

The customers are not professionals. Never assume that “maybe the customer means...” or “maybe the customer mentioned this symptom”.

>> GO TO 2.

## 2. SELF-DIAGNOSIS WITH CONSULT

1. Perform “All DTC Reading” with CONSULT.
2. Check if any DTC is detected in self-diagnosis results of “ICC/ADAS”, “LASER/RADAR”, and “BSW/BUZZER”.

Is any DTC detected?

YES >> GO TO 5.

NO >> GO TO 3.

## 3. ACTION TEST

Perform the ICC system action test to check the operation status. Refer to [CCS-95, "Description"](#).  
Check if any other malfunctions occur.

>> GO TO 4.

## 4. SYMPTOM DIAGNOSIS

Perform the applicable diagnosis according to the diagnosis chart by symptom. Refer to [CCS-119, "Symptom Table"](#).

>> GO TO 6.

## 5. TROUBLE DIAGNOSIS BY DTC

1. Check the DTC in the self-diagnosis results.
2. Perform trouble diagnosis for the detected DTC. Refer to [CCS-58, "DTC Index"](#) (ICC/ADAS) or [CCS-63, "DTC Index"](#) (LASER/RADAR) or [DAS-280, "DTC Index"](#) (BSW/BUZZER).

### NOTE:

If “DTC: U1000” is detected, first diagnose the CAN communication system or ITS communication system.

>> GO TO 6.

## 6. MALFUNCTIONING PART REPAIR

Repair or replace the identified malfunctioning parts.

>> GO TO 7.

## 7. REPAIR CHECK (SELF-DIAGNOSIS WITH CONSULT)

1. Erases self-diagnosis results.
2. Perform “All DTC Reading” again after repairing or replacing the malfunctioning parts.
3. Check if any DTC is detected in self-diagnosis results of “ICC/ADAS”, “LASER/RADAR”, and “BSW/BUZZER”.

Is any DTC detected?

YES >> GO TO 5.

NO >> GO TO 8.

## 8. REPAIR CHECK (ACTION TEST)

Perform the ICC system action test. Check if the malfunction symptom is solved or no other symptoms occur.

Is there any malfunction symptom?

YES >> GO TO 4.

NO >> INSPECTION END

A  
B  
C  
D  
E  
F  
G  
H  
I  
J  
K  
L  
M  
N  
P

CCS

## ADDITIONAL SERVICE WHEN REPLACING ICC SENSOR

< BASIC INSPECTION >

[ICC]

---

### ADDITIONAL SERVICE WHEN REPLACING ICC SENSOR

#### Description

INFOID:000000009644232

- Always perform the radar alignment after removing and installing or replacing the ICC sensor.  
**CAUTION:**  
**The system does not operate normally unless the radar alignment is performed. Always perform it.**
- Perform the ICC system action test to check that the ICC system operates normally.

#### Work Procedure

INFOID:000000009644233

#### 1. PERFORM RADAR ALIGNMENT

---

Perform the radar alignment. Refer to [CCS-83, "TYPE 1 : Description"](#).

>> GO TO 2.

#### 2. ICC SYSTEM ACTION TEST

- 
1. Perform the ICC system action test. Refer to [CCS-95, "Description"](#).
  2. Check that the ICC system operates normally.

>> INSPECTION END

## ICC SENSOR ALIGNMENT

### Application Notice

INFOID:000000010304532

Type	Description
TYPE 1	When using KV99112700 for radar alignment.
TYPE 2	When using following tools for radar alignment. <ul style="list-style-type: none"> <li>• ICC Alignment Kit (1-20-2721-1-IF)</li> <li>• Wheel Adaptor (1-20-2722-1-IF)</li> <li>• ICC alignment kit attachment board (J-50808)</li> </ul>

### TYPE 1

#### TYPE 1 : Description

INFOID:000000009644234

#### OUTLINE OF RADAR ALIGNMENT PROCEDURE

- A 4-wheel vehicle alignment must be performed before proceeding with radar alignment procedure.
- Always perform the radar alignment after removing and installing or replacing the ICC sensor.

**WARNING:**

**Radio waves could adversely affect electric medical equipment. Those who use a pacemaker should contact the electric medical equipment manufacturer for the possible influences before use.**

**CAUTION:**

**The system does not operate normally unless the radar alignment is performed. Always perform it.**

1. Set the distance sensor target board (SST: KV99112700) to the correct position in front of the vehicle.
2. Set the radar alignment mode (“MILLIWAVE RADAR ADJUST” on “Work support”) with CONSULT, and then perform the adjustment according to the display. (ICC sensor automatically adjusts.)

#### CAUTIONARY POINT FOR RADAR ALIGNMENT PROCEDURE

**CAUTION:**

- For radar alignment procedure, choose a level location with a few meter of working space in front and surrounding the vehicle.
- Vehicle must be stationary and unoccupied during the whole alignment procedure.
- Any slight vibration during the alignment procedure can cause the test to fail. If this happens, you will have to restart the alignment process.
- The ignition switch must be in the ON position.
- The battery voltage must not fall below 12 volts during the whole alignment procedure. Failure to maintain adequate battery voltage will cause the test to fail. If this happens, you will have to restart the alignment process.
- The ICC target board must be set in front of the vehicle facing the sensor.
- Adjust the radar alignment with CONSULT. (The radar alignment procedure cannot be adjusted without CONSULT.)
- Never enter the vehicle during radar alignment.
- Never block the area between the radar and the ICC target board at any time during the alignment process.
- Accurate steering wheel setting is crucial. Once set, do not disturb the steering wheel for the remainder of the alignment procedure.
- For proper system operation and adjustment, all vehicle wheels must be of the same size.

#### TYPE 1 : Work Procedure (Preparation)

INFOID:000000009644235

#### 1. ADVANCE PREPARATION FOR RADAR ALIGNMENT

1. Adjust all tire pressure to the specified value.
2. Empty the vehicle. (Remove any luggage from the passenger compartment, trunk room, etc.)
3. Shift the selector lever to “P” position, and release the parking brake.
4. Fully fill the fuel tank, and then check that the coolant and oils are filled up to correct level.

# ICC SENSOR ALIGNMENT

[ICC]

< BASIC INSPECTION >

5. Clean the ICC sensor area ① of the front bumper grille.

>> GO TO 2.

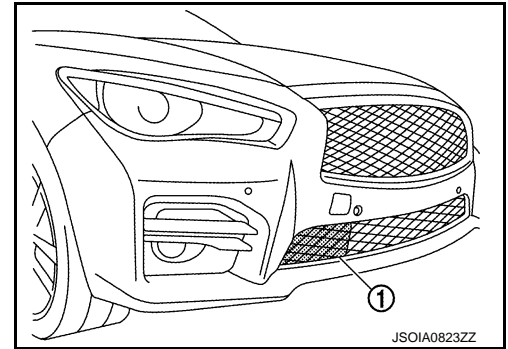

## 2. RADAR ALIGNMENT OPERATION AREA

Position the vehicle in a place that is level and where ① area can be secured.

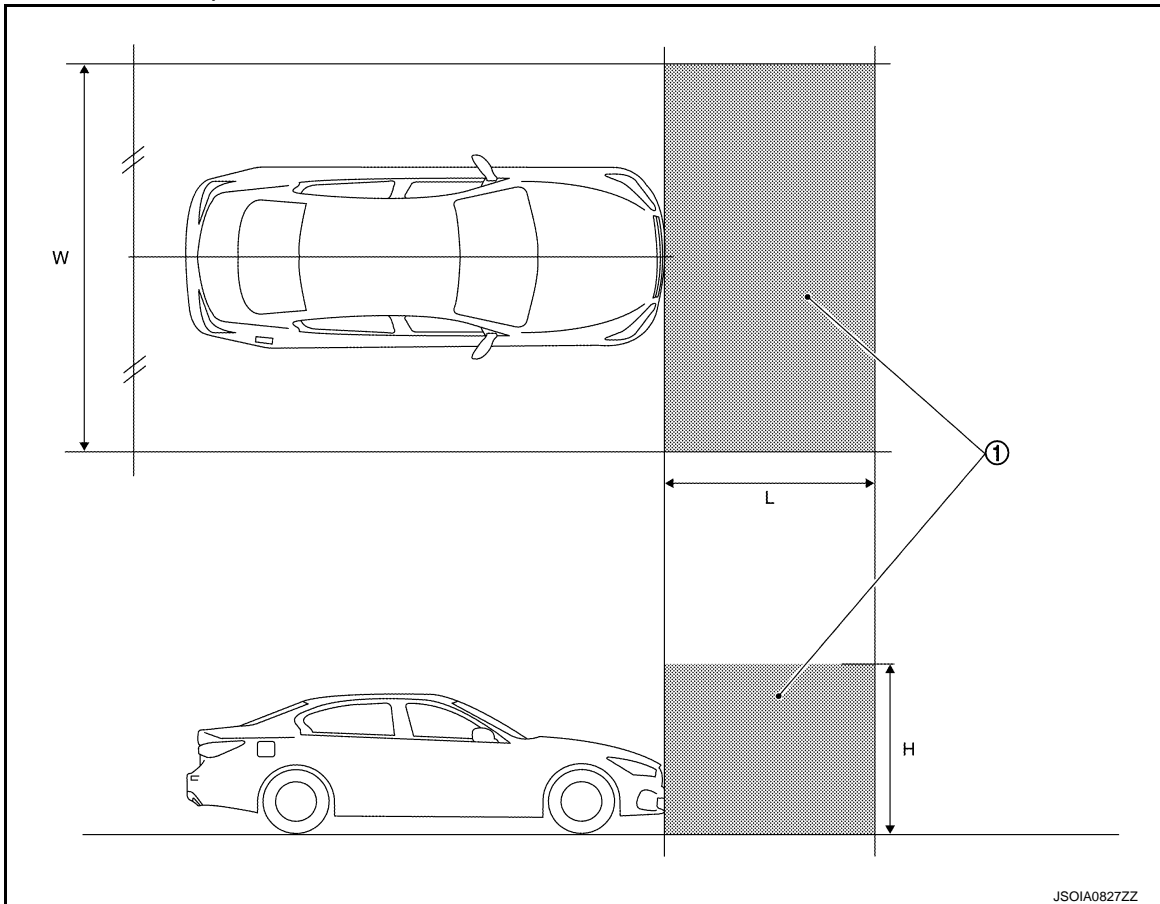

W : 3000 mm (118.11 in)

L : 2000 mm (78.74 in)

H : 2000 mm (78.74 in)

### NOTE:

① is a no object zone.

>> Go to [CCS-84. "TYPE 1 : Work Procedure \(Setting The ICC Target Board\)".](#)

## TYPE 1 : Work Procedure (Setting The ICC Target Board)

INFOID:000000009644236

### DESCRIPTION

Accurate adjustment of the radar alignment requires that the ICC sensor target board be accurately positioned.

### CAUTION:

# ICC SENSOR ALIGNMENT

< BASIC INSPECTION >

[ICC]

If the radar alignment is adjusted with the distance sensor target board in the incorrect position, the ICC system does not function normally.

## 1. DISTANCE SENSOR TARGET BOARD HEIGHT ADJUSTMENT

Adjust the base of ICC target board to approximately 30 mm (1.18 in) from the ground.

>> GO TO 2.

## 2. PREPARATION OF SETTING DISTANCE SENSOR TARGET BOARD (1)

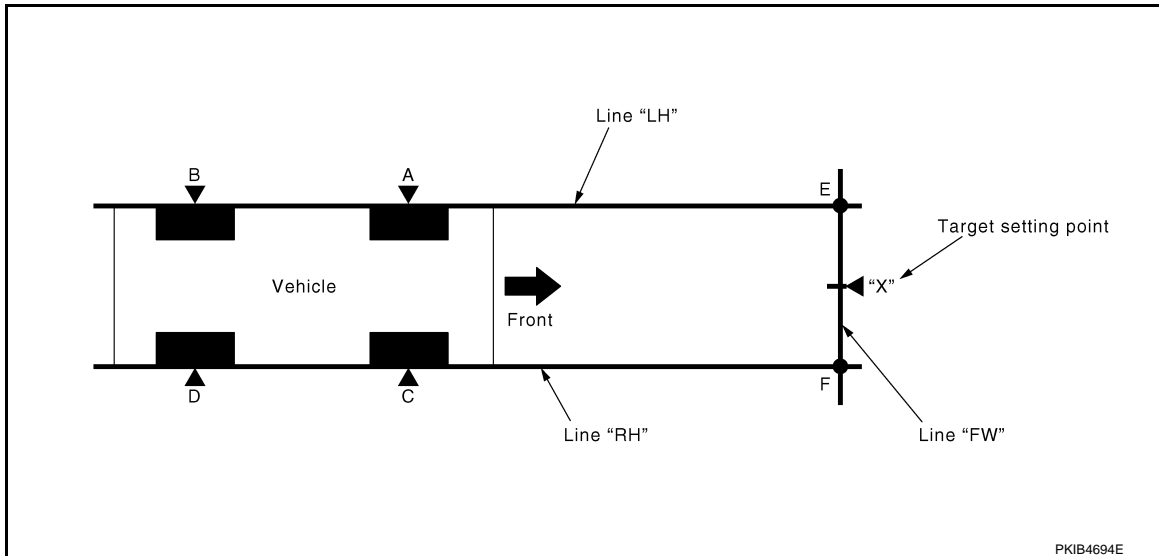

“A” – “E” (“C” – “F”) : 1727 mm (67.99 in)

1. Mark points “A”, “B”, “C” and “D” at the center of the lateral surface of each wheels.

**NOTE:**

Hang a string with a cone from the fender so as to pass through the center of wheel, and then mark a point at the center of the lateral surface of the wheel.

2. Draw line “LH” passing through points “A” and “B” on the left side of vehicle.

**NOTE:**

Approximately 4 m (13.12 ft) or more from the front end of vehicle.

3. Mark point “E” on the line “LH” at the positions 1727 mm (67.99 in) from point “A”.

4. Draw line “RH” passing through points “C” and “D” on the right side of vehicle in the same way as step 2.

**NOTE:**

Approximately 2 m (6.56 ft) or more from the front end of vehicle.

5. Mark point “F” on the line “RH” at the positions 1727 mm (67.99 in) from point “C”.
6. Draw line “FW” passing through the points “E” and “F” on the front side of vehicle.
7. Mark point “X” at the center of point “E” and “F” on the line “FW”.

**CAUTION:**

Make sure that “E” to “X” is equal to “F” to “X”.

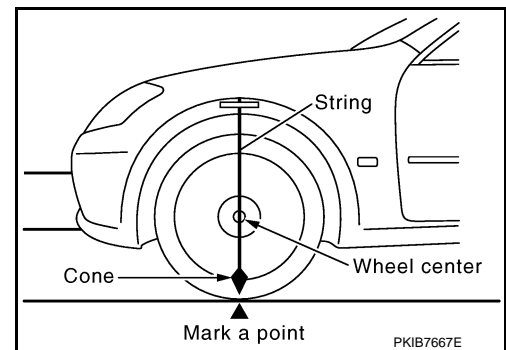

A  
B  
C  
D  
E  
F  
G  
H  
I  
J  
K  
L  
M  
N  
P

CCS

# ICC SENSOR ALIGNMENT

[ICC]

## < BASIC INSPECTION >

8. With point "X" as the starting point, mark point "G" on "F" point side 368 mm (14.49 in).

L1 : 1727 mm (67.99 in)

L2 : 368 mm (14.49 in)

>> GO TO 3.

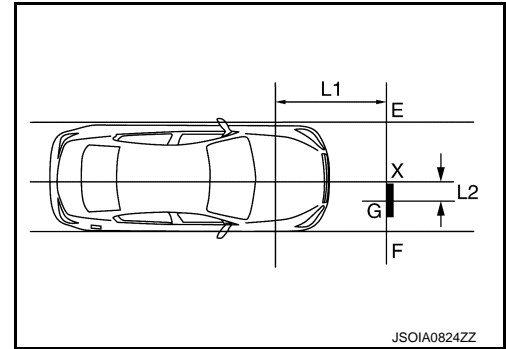

## 3.SETTING DISTANCE SENSOR TARGET BOARD

Place the center of ICC target board on point "G" at line "E-F" and install the ICC target board.

### CAUTION:

For performing the radar alignment correctly, securely install (ICC target board) to be parallel with the "E-F" line.

>> GO TO 4.

## 4.CHECK THE DISTANCE SENSOR TARGET BOARD INSTALLATION AREA

Do not place anything other than distance sensor target board in the space shown in the figure (view from top).

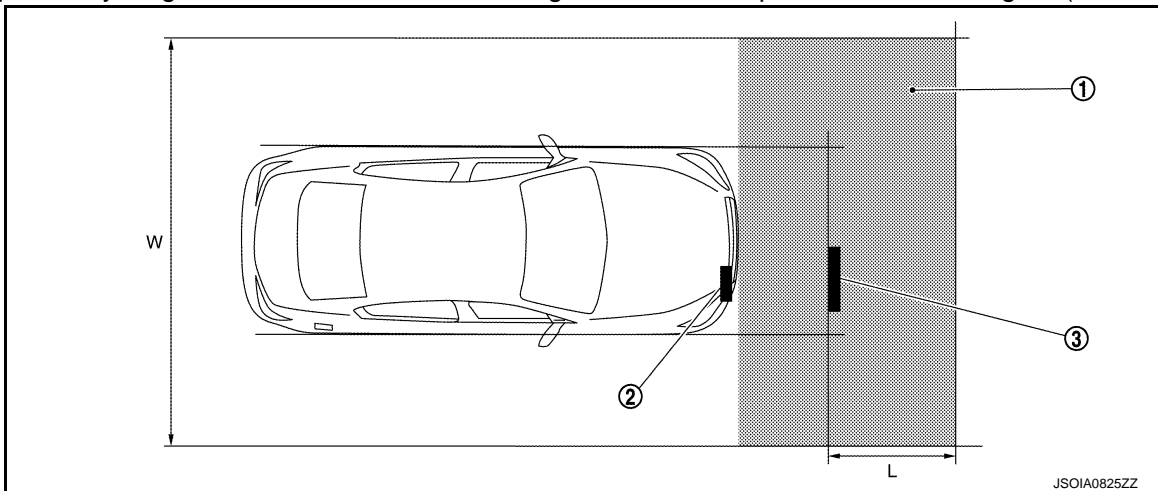

① No object zone

W. 3000 mm (118.11 in)

② ICC sensor

L. 1500 mm (59.06 in)

③ ICC target board

>> Go to [CCS-86, "TYPE 1 : Work Procedure \(Radar Alignment\)"](#).

## TYPE 1 : Work Procedure (Radar Alignment)

INFOID:000000009644237

### DESCRIPTION

The radar alignment is performed automatically with CONSULT.

### CAUTION:

Perform all necessary work for radar alignment until the adjustment completes as shown in the procedure. If the procedure does not complete, the ICC system is inoperable.

### 1.PERFORM RADAR ALIGNMENT

1. Start the engine.
2. Connect CONSULT and select "Work support" of "LASER/RADAR".
3. Select "MILLIWAVE RADAR ADJUST" after the "Work support" screen is displayed.

### NOTE:

Confirm the following items;

- The target should be accurately placed.

# ICC SENSOR ALIGNMENT

< BASIC INSPECTION >

[ICC]

- The vehicle should be stopped.
- 4. Select "Start" after the "MILLIWAVE RADAR ADJUST" screen is displayed.

**CAUTION:**

**Never select "Start" when the target is not accurately placed.**

- 5. Select "Start" after the preparation information is displayed.
- 6. Select "Next" after the "Starting alignment." screen is displayed.

**NOTE:**

If the radar is in alignment at this time, "Alignment in progress" is displayed. It may take several 10s of seconds until the result is displayed.

- 7. Confirm the displayed item.
  - "Alignment completed.": Go to 8.
  - Except "Alignment completed.": Perform the following services.

Displayed item	Possible cause	Service procedure
Alignment condition is not ready.	<ul style="list-style-type: none"> <li>• DTC is detected (Except C1A12).</li> <li>• The position of the ICC target board is not correct.</li> <li>• Vehicle is moving.</li> </ul>	Check the vehicle condition and perform radar alignment again.
Alignment condition is not ready. (Stop the vehicle.)	Vehicle is moving.	Stop the vehicle and perform radar alignment again.
Target is not detected.	<ul style="list-style-type: none"> <li>• A target is not-yet-placed. (The ICC sensor cannot detect target)</li> <li>• The position of the ICC target board is not correct.</li> <li>• The position of the ICC sensor is not correct.</li> </ul>	Check the target board condition and perform radar alignment again.
Sensor malfunction.	ICC sensor malfunction.	Check the vehicle condition and perform radar alignment again.

**NOTE:**

Replace ICC sensor if "Sensor malfunction." is repeatedly indicated.

- 8. Confirm displayed value.

Displayed item	Monitor item	Reference value
Alignment completed.	FACTORY AIM L/R	Less than 3.00 deg
	FACTORY AIM U/D	Less than 3.00 deg
	AIMING VALUE L/R	Less than 3.00 deg
	AIMING VALUE U/D	Less than 3.00 deg

- Within reference value: Go to 9.
- Outside of reference value: Check the target board condition and perform radar alignment again.

**NOTE:**

- Check the condition of the ICC sensor installation.
- Check the vehicle for damage.
- Replace ICC sensor if it is outside the reference value, even when ICC sensor installation is installed normally and the vehicle is not damaged.

- 9. Select "OK" after the "No error detected." is displayed.
- 10. Select "OK" after the "End of alignment." is displayed.

**CAUTION:**

**Once "MILLIWAVE RADAR ADJUST" is started with CONSULT, always continue the work until the horizontal radar alignment is completed successfully. If the job is stopped midway, the radar alignment is not adjusted and the ICC system cannot operate.**

>> RADAR ALIGNMENT END

## TYPE 2

### TYPE 2 : Description

INFOID:000000010249675

### OUTLINE OF RADAR ALIGNMENT PROCEDURE

- A 4-wheel vehicle alignment must be performed before proceeding with radar alignment procedure.



# ICC SENSOR ALIGNMENT

[ICC]

## < BASIC INSPECTION >

- Always perform the radar alignment after removing and installing or replacing the ICC sensor.
- Always perform the radar alignment if rear axle toe settings have been made.

### **WARNING:**

Radio waves could adversely affect electric medical equipment. Those who use a pacemaker should contact the electric medical equipment manufacturer for the possible influences before use.

### **CAUTION:**

The system does not operate normally unless the ICC sensor is aligned properly.

1. Required tools, refer to [CCS-88, "TYPE 2 : Required Tools"](#).
2. Preparation, refer to [CCS-89, "TYPE 2 : Preparation"](#).
3. Vehicle set up, refer to [CCS-90, "TYPE 2 : Vehicle Set Up"](#).
4. Setting the ICC target board, refer to [CCS-92, "TYPE 2 : Setting The ICC Target Board"](#).
5. ICC sensor adjustment, refer to [CCS-93, "TYPE 2 : ICC Sensor Adjustment"](#).

## CAUTIONARY POINT FOR RADAR ALIGNMENT PROCEDURE

### **CAUTION:**

- For radar alignment procedure, choose a level location with a few feet of working space in front and surrounding the vehicle.
- Vehicle must be stationary and unoccupied during the whole alignment procedure.
- Any slight vibration during the alignment procedure can cause the test to fail. If this happens, you will have to restart the alignment process.
- The battery voltage must not fall below 12 volts during the whole alignment procedure. Failure to maintain adequate battery voltage will cause the test to fail. If this happens, you will have to restart the alignment process.
- The ICC target board must be set in front of the vehicle facing the sensor.
- Adjust the radar alignment with CONSULT. (The radar alignment procedure cannot be adjusted without CONSULT.)
- Never enter the vehicle during radar alignment.
- Never block the area between the radar and the ICC target board at any time during the alignment process.
- Accurate steering wheel setting is crucial. Once set, do not disturb the steering wheel for the remainder of the alignment procedure.
- For proper system operation and adjustment, all vehicle wheels must be of the same size.

## TYPE 2 : Required Tools

INFOID:000000010249676

- ICC alignment kit in addition to one of the following:
  - a) Hunter self-centering wheel adapter (Hunter wheel alignment tool)
  - b) Special Service Tool kit 1-20-2722-1-IF (kit SCA W/Tire Clamp-ICC Aiming)

The following ICC alignment kit are necessary to perform the ICC sensor alignment:

- ICC target board.
  - ①: Position 1, with top tilted 2° toward vehicle (Not used).
  - ②: Position 2, vertical.
  - ③: Position 3, with top tilted 2° away from vehicle (Not used).

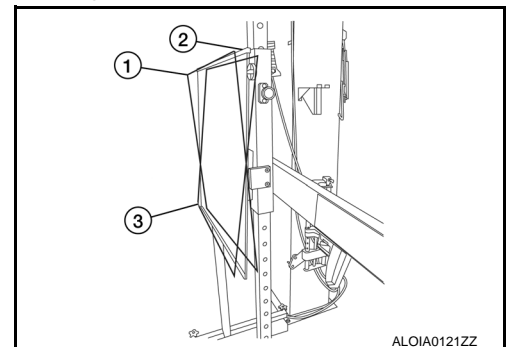



# ICC SENSOR ALIGNMENT

[ICC]

## < BASIC INSPECTION >

- Hunter self-centering wheel adapter ① [shown with laser assembly ② installed] (Hunter alignment rack head may be substituted).

**NOTE:**

- Retailers that are not equipped with a Hunter self-centering wheel adapter will require the following kit:  
Part No. 1-20-2722-1-IF (kit SCA W/Tire Clamp-ICC Aiming)
- Directional arrows ① and ② are shown to illustrate the direction of the laser assembly beams.

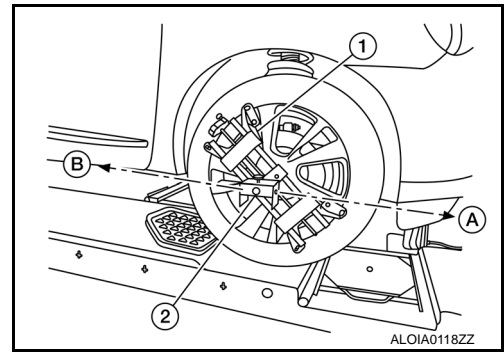

- Laser assembly (with bi-directional laser beam) as shown in the illustration.

- Tightening knob ①
- Power ON/OFF button ②
- Front laser beam opening ③
- Rear laser beam opening ④
- Attaching shaft ⑤

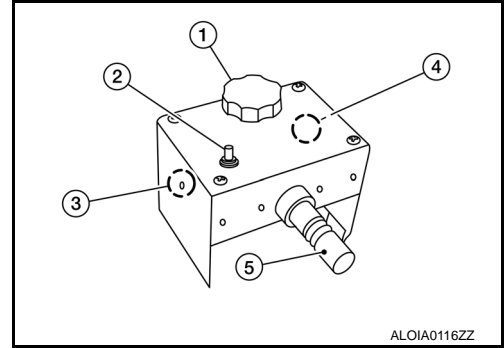

- Stationary target as shown in the illustration.

- Stationary target ①
- Laser signal reception plate ②

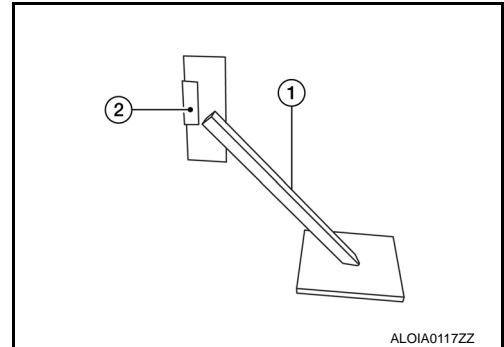

- ICC alignment kit attachment board as shown in the illustration.

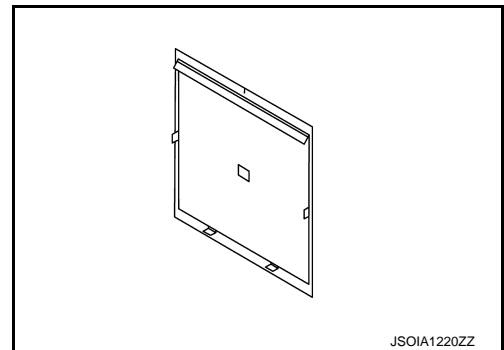

## TYPE 2 : Preparation

INFOID:000000010249677

### 1. ADVANCE PREPARATION FOR RADAR ALIGNMENT PROCEDURE

1. Adjust all tire pressure to the specified value.
2. Empty the vehicle. (Remove any luggage from the passenger compartment, luggage room, etc.)
3. Shift the selector lever to "P" position, and release the parking brake.
4. Fully fill the fuel tank, and then check that the coolant and oils are filled up to correct level.

A  
B  
C  
D  
E  
F  
G  
H  
I  
J  
K  
L  
M  
N  
P

# ICC SENSOR ALIGNMENT

[ICC]

## < BASIC INSPECTION >

5. Clean the ICC sensor area ① of the front bumper grille.

>> Refer to [CCS-90. "TYPE 2 : Vehicle Set Up"](#).

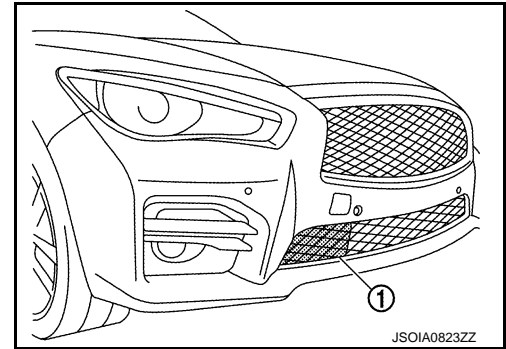

INFOID:000000010249678

## TYPE 2 : Vehicle Set Up

### DESCRIPTION

Accurate adjustment of the radar alignment requires that the ICC target board, wheel adapter, laser assembly, and stationary target be properly positioned.

### CAUTION:

**If the radar alignment is adjusted with the ICC target board, wheel adapter, laser assembly, or stationary target in the incorrect position, the ICC system will not function properly or the alignment procedure may not be completed successfully.**

### 1. PREPOSITION TARGET BOARD

#### NOTE:

- To identify the sensor wave axis center, measure the point ① as shown in the illustration.

**A : 368 mm (14.49 in)**

**B : 320 mm (12.6 in)**

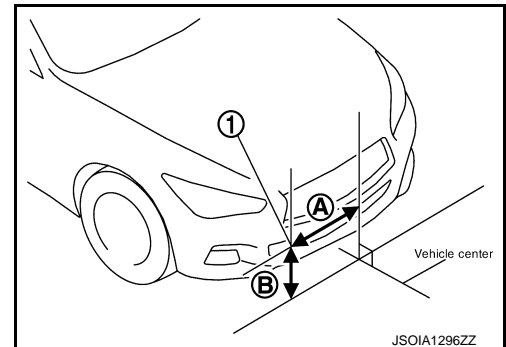

- ICC target board setting must be in the center position. (Position 2)
- Attaching the ICC alignment kit attachment board to the ICC target board.

1. Position the ICC target board in front facing the right front side of the vehicle:
  - Place the marked center of the ICC target board ① 1060 mm (41.73 in.)  $\pm$  50 mm (1.97 in) facing the ICC sensor.
  - Adjust the height of the ICC target board using the adjustable nut ② to achieve the proper height. The up/down tolerance is  $\pm$  30 mm (1.18 in).
  - Adjust the ICC target board lateral position aligning the marked center of the board horizontally with the center of the ICC sensor. The right/left tolerance is  $\pm$  80 mm (3.15 in).
2. Extend the machined arm of the ICC target board exposing the reflective surface ③ to the right front side of the vehicle.

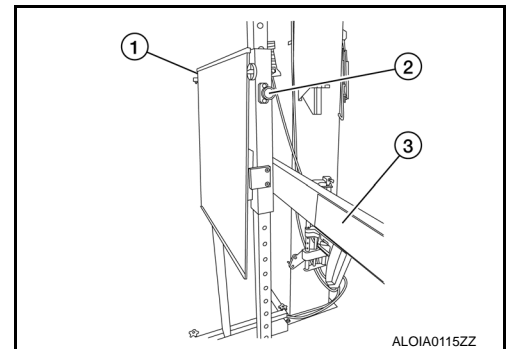

# ICC SENSOR ALIGNMENT

[ICC]

## < BASIC INSPECTION >

- Place one side of the laser assembly ② flush against the center of the ICC target board ① to assist in the positioning.

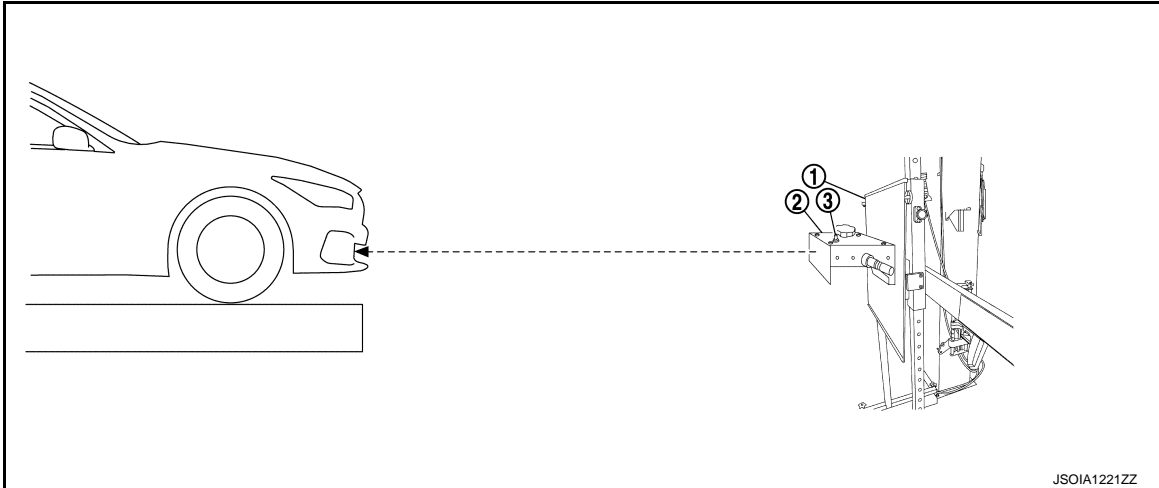

- Turn the laser assembly ON ③ allowing the laser beam to emit through the opening of the laser assembly toward the center of the ICC sensor.
- Move the ICC target board ① as necessary so that center of ICC target board aligns with center of ICC sensor.
- Turn the laser assembly OFF when done.

### Are using Hunter alignment equipment?

YES >> Refer to Hunter's equipment instructions for complete vehicle set up and ICC target board setting. Then, refer to [CCS-93. "TYPE 2 : ICC Sensor Adjustment"](#).

NO >> GO TO 2.

## 2. INSTALLING LASER ASSEMBLY

### NOTE:

- Insure the steering wheel is positioned in the center straight forward position.
- Insure all 4 vehicle wheels do not contain any physical damage.

- Install the wheel adapter ① on the right front wheel.
- Mount the laser assembly ② to the wheel adapter ① as shown in the figure.

### NOTE:

When the power switch is turned ON, the front laser signal ① will be emitted toward the front ICC target board, and the rear laser signal ② will be emitted toward the rear of the vehicle.

>> GO TO 3.

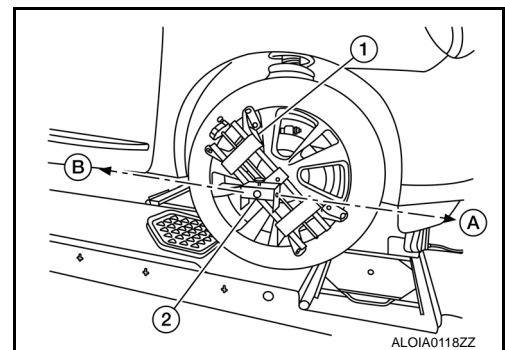

## 3. SETTING UP STATIONARY TARGET

- Place the stationary target next to the right rear tire as shown in the figure.

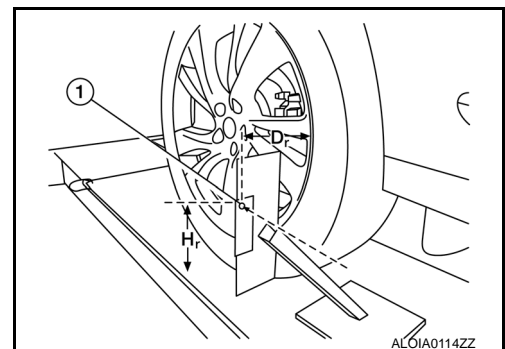

# ICC SENSOR ALIGNMENT

[ICC]

## < BASIC INSPECTION >

- Turn the laser assembly ON allowing the laser beam to be emitted through the front and rear laser assembly openings.
- Measure and record the distance ( $D_r$ ) between the edge of the right rear wheel and the laser beam (1) on the stationary target (horizontal line).
- Measure and record the height ( $H_r$ ) between the laser beam (1) on the stationary target and ground level (vertical line).
- Measure and record the distance ( $D_f$ ) between the edge of the right front wheel and the laser beam signal/opening (1) on the laser assembly (horizontal line).
- Measure and record the height ( $H_f$ ) between the laser beam signal/opening (1) on the laser assembly and ground level (vertical line).

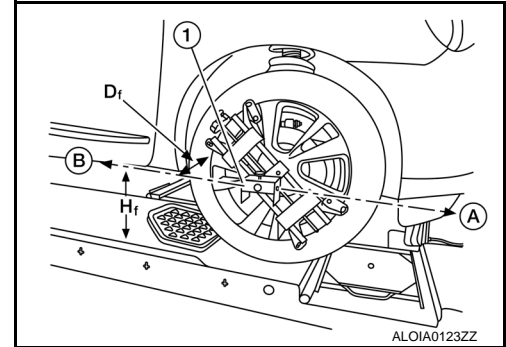

### NOTE:

- Horizontal adjustment [front distance ( $D_f$ ) and rear distance ( $D_r$ )] is accomplished by slowly turning the steering wheel until the 2 distances are the same.
  - Vertical adjustment [front height ( $H_f$ ) and rear height ( $H_r$ )] is accomplished by rotating the laser assembly around its axis until the two heights are the same.
  - Directional arrows (A) and (B) are shown to illustrate the direction of the laser assembly beams.
- Adjust laser beam as necessary until the two distances match and the two heights match.

### NOTE:

Must be verify both horizontal and vertical adjustments anytime one adjustment is made.

>> Refer to [CCS-92, "TYPE 2 : Setting The ICC Target Board"](#).

## TYPE 2 : Setting The ICC Target Board

INFOID:000000010249679

### DESCRIPTION

Accurate adjustment of the radar alignment requires that the ICC target board be accurately positioned.

### CAUTION:

If the radar alignment is adjusted with the ICC target board in the incorrect position, the ICC system will not function properly or the alignment procedure may not be completed successfully.

### 1. ICC TARGET BOARD FINAL SETTING

- With the ICC target board arm extended, the laser beam (1) emitted by the laser assembly (A) will be reflected back (B) toward the laser assembly.

### NOTE:

When adjusted properly, reflected laser beam (B) must align with emitted laser beam (A) and the two laser beams will be seen as one.

- Rotate the ICC target board to achieve the necessary horizontal adjustment.
- Adjust the ICC target board leveling screws to achieve the necessary vertical adjustment.

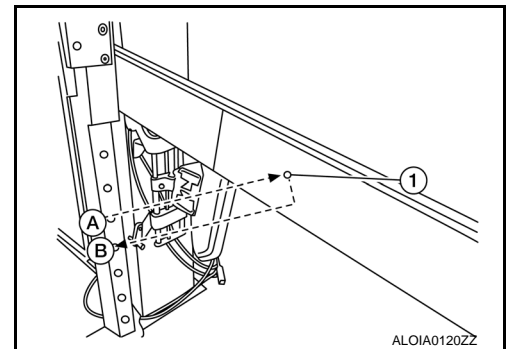

- The figure shown illustrates the laser beam (A) emitted by the laser assembly (1) and its reflection (B) off of the ICC target board arm.

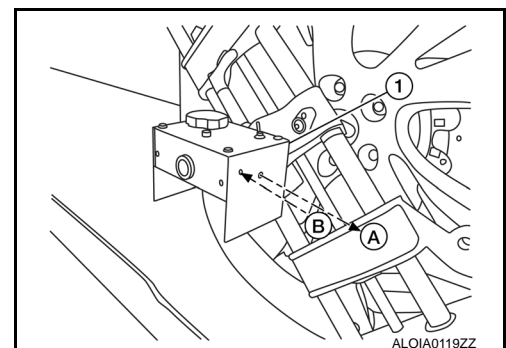

# ICC SENSOR ALIGNMENT

< BASIC INSPECTION >

[ICC]

>> GO TO 2.

## 2. CHECK THE POSITION OF THE ICC TARGET BOARD

Do not place anything other than the ICC target board in the space shown in front of the vehicle (view from top).

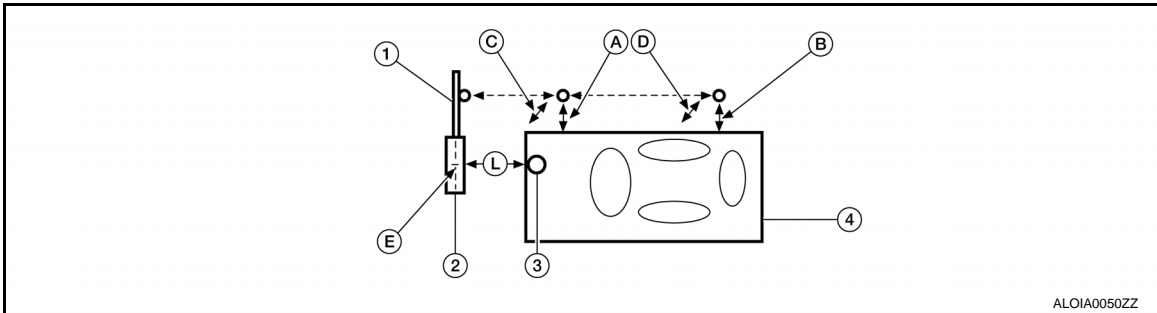

- |   |  |  |
|---|--|--|
| ① ICC target board arm                                  | ② ICC target board                                     | ③ ICC sensor   |
| ④ Vehicle   |  |  |
| Ⓐ Distance between front wheel and laser beam ( $D_f$ ) | Ⓑ Distance between rear wheel and laser beam ( $D_r$ ) | Ⓒ Height between front laser beam and ground ( $H_f$ ) |
| Ⓓ Height between rear laser beam and ground ( $H_r$ )   | Ⓔ ICC target board center position                     | Ⓕ 1010 - 1110 mm (39.76 - 43.7 in)                     |

>> Refer to [CCS-93, "TYPE 2 : ICC Sensor Adjustment"](#).

## TYPE 2 : ICC Sensor Adjustment

INFOID:000000010249680

### DESCRIPTION

The radar alignment is performed automatically with CONSULT.

#### CAUTION:

**Perform all necessary work for radar alignment until the adjustment completes as shown in the procedure. If the procedure does not complete, the ICC system is inoperable.**

## 1. PERFORM RADAR ALIGNMENT

1. Start the engine.
2. Connect CONSULT and select "Work support" of "LASER/RADAR".
3. Select "MILLIWAVE RADAR ADJUST" after the "Work support" screen is displayed.

#### NOTE:

- Confirm the following items;
- The target should be accurately placed.
  - The vehicle should be stopped.

4. Select "Start" after the "MILLIWAVE RADAR ADJUST" screen is displayed.

#### CAUTION:

**Never select "Start" when the target is not accurately placed.**

5. Select "Start" after the preparation information is displayed.
6. Select "Next" after the "Starting alignment." screen is displayed.

#### NOTE:

If the radar is in alignment at this time, "Alignment in progress" is displayed. It may take several 10s of seconds until the result is displayed.

7. Confirm the displayed item.
  - "Alignment completed.": Go to 8.
  - Except "Alignment completed.": Perform the following services.

A  
B  
C  
D  
E  
F  
G  
H  
I  
J  
K  
L  
M  
N  
P

CCS

# ICC SENSOR ALIGNMENT

< BASIC INSPECTION >

[ICC]

Displayed item	Possible cause	Service procedure
Alignment condition is not ready.	<ul style="list-style-type: none"> <li>• DTC is detected (Except C1A12).</li> <li>• The position of the ICC target board is not correct.</li> <li>• Vehicle is moving.</li> </ul>	Check the vehicle condition and perform radar alignment again.
Alignment condition is not ready. (Stop the vehicle.)	Vehicle is moving.	Stop the vehicle and perform radar alignment again.
Target is not detected.	<ul style="list-style-type: none"> <li>• A target is not-yet-placed. (The ICC sensor cannot detect target)</li> <li>• The position of the ICC target board is not correct.</li> <li>• The position of the ICC sensor is not correct.</li> </ul>	Check the target board condition and perform radar alignment again.
Sensor malfunction.	ICC sensor malfunction.	Check the vehicle condition and perform radar alignment again.

**NOTE:**

Replace ICC sensor if “Sensor malfunction.” is repeatedly indicated.

8. Confirm displayed value.

Displayed item	Monitor item	Reference value
Alignment completed.	FACTORY AIM L/R	Less than 3.00 deg
	FACTORY AIM U/D	Less than 3.00 deg
	AIMING VALUE L/R	Less than 3.00 deg
	AIMING VALUE U/D	Less than 3.00 deg

- Within reference value: Go to 9.

- Outside of reference value: Check the target board condition and perform radar alignment again.

**NOTE:**

- Check the condition of the ICC sensor installation.
- Check the vehicle for damage.
- Replace ICC sensor if it is outside the reference value, even when ICC sensor installation is installed normally and the vehicle is not damaged.

9. Select “OK” after the “No error detected.” is displayed.

10. Select “OK” after the “End of alignment.” is displayed.

**CAUTION:**

Once “MILLIWAVE RADAR ADJUST” is started with CONSULT, always continue the work until the horizontal radar alignment is completed successfully. If the job is stopped midway, the radar alignment is not adjusted and the ICC system cannot operate.

>> RADAR ALIGNMENT END

## ACTION TEST

### Description

INFOID:000000009644238

Always perform the ICC system action test to check that the ICC system operates normally after replacing the ICC sensor or repairing any ICC system malfunction.

**CAUTION:**

- Always drive safely when performing the action test.
- Turn the DCA system to OFF when performing the action test.

### Work Procedure (Vehicle-To-Vehicle Distance Control Mode)

INFOID:000000009644239

**NOTE:**

- When there is no vehicle ahead, drive at the set speed steadily.
- When there is a vehicle ahead, control to maintain distance from the vehicle ahead, watching its speed.
- The running speed can be set between 32 km/h (20 MPH) and 144 km/h (90 MPH).

**CAUTION:**

**Never set the cruise speed exceeding the posted speed limit.**

#### 1. CHECK FOR MAIN SWITCH

1. Start the engine.
2. Press the MAIN switch ① (less than 1.5 seconds).

Information display status

- |                               |   |                |
|-------------------------------|---|----------------|
| MAIN switch indicator ②       | : | ON             |
| Set distance indicator ③      | : | Long mode      |
| Set vehicle speed indicator ④ | : | " _ _ _ "      |
|                               | : | "km/h" ("MPH") |

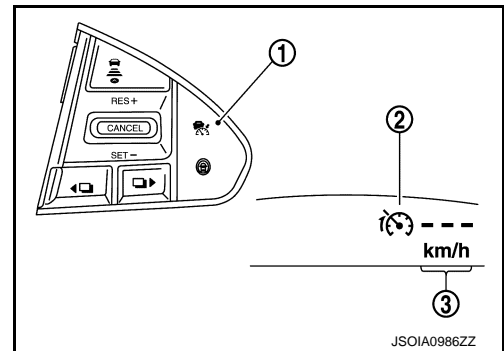

3. Check the ICC system display on the information display to check that the vehicle-to-vehicle distance control mode is ready for activation.
4. Press the MAIN switch, and check that the ICC system display on the information display turns OFF when the ICC system is deactivated.
5. Check that the ICC system display on the information display turns OFF after starting the engine again.

>> GO TO 2.

#### 2. CHECK FOR DISTANCE SWITCH

1. Start the engine.
2. Press the MAIN switch (less than 1.5 seconds).
3. Press the DISTANCE switch.



A  
B  
C  
D  
E  
F  
G  
H  
I  
J  
K  
L  
M  
N  
P

# ACTION TEST

< BASIC INSPECTION >

[ICC]

4. Check that the set distance indicator changes display in order of: (Long)→(Middle)→(Short).

Distance	Display	Approximate distance at 100 km/h (60 MPH) [m (ft)]
Long	 <b>100 km/h</b>	60 (200)
Middle	 <b>100 km/h</b>	45 (150)
Short	 <b>100 km/h</b>	30 (90)

JSOIA1051GB

**NOTE:**

When the MAIN switch is turned ON, initial setting set to (Long).

>> GO TO 3.

### 3. CHECK FOR RESUME/ACCELERATE, SET/COAST, AND CANCEL SWITCHES

1. Check that RESUME/ACCELERATE, SET/COAST, CANCEL switches are operated smoothly.
2. Check that switches come up as hand is released from the switches.

>> GO TO 4.

### 4. SET CHECKING (1)

1. Start the engine.
2. Press the MAIN switch (less than 1.5 seconds) and turn the vehicle-to-vehicle distance control mode ON.
3. Drive the vehicle at 32 km/h (20 MPH) or more.
4. Push down the SET/COAST switch.
5. Check that the desired speed is set and vehicle-to-vehicle distance control mode control starts when releasing SET/COAST switch.

**NOTE:**

The set vehicle speed is indicated on the set vehicle speed indicator in the ICC system display on the information display.

>> GO TO 5.

### 5. CHECK FOR INCREASE OF CRUISING SPEED (1)

1. Set the vehicle-to-vehicle distance control mode at desired speed.
2. Check that the set speed increases by 1 km/h (1 MPH) as RESUME/ACCELERATE switch is pushed up.

**NOTE:**

The maximum set speed of the vehicle-to-vehicle distance control mode is 144 km/h (90 MPH).

**CAUTION:**

**Never set the cruise speed exceeding the posted speed limit.**

>> GO TO 6.

### 6. CHECK FOR DECREASE OF CRUISING SPEED (1)

1. Set the vehicle-to-vehicle distance control mode at desired speed.
2. Check that the set speed decreases by 1 km/h (1 MPH) as SET/COAST switch is pushed down.

**NOTE:**

- The minimum set speed is approximately 32 km/h (20 MPH).



# ACTION TEST

< BASIC INSPECTION >

[ICC]

- Cancel the control automatically when the vehicle speed is less than approximately 24 km/h (15 MPH) and when the system does not detect any vehicle ahead.

>> GO TO 7.

## 7.SET CHECKING (2)

1. Stop the vehicle.
2. Drive the vehicle at less than approximately 32 km/h (20 MPH).
3. Push down the SET/COAST switch when the system detects a vehicle ahead.
4. Check that the vehicle-to-vehicle distance control mode is performed so that the vehicle maintains a proper distance according to the vehicle speed [maximum: approximately 32 km/h (20 MPH)] when releasing SET/COAST switch.

### NOTE:

- The vehicle-to-vehicle distance control mode cannot be set when the vehicle speed is less than 32 km/h (20 MPH) and when a vehicle ahead is not detected.
- Cancel the control automatically when the vehicle speed is 24 km/h (15 MPH) or less during the control and when the system does not detect any vehicle ahead.
- The set vehicle speed indicator in the ICC system display on the information display is set to 32 km/h (20 MPH).

>> GO TO 8.

## 8.CHECK FOR INCREASE OF CRUISING SPEED (2)

1. Set the vehicle-to-vehicle distance control mode when the vehicle speed is less than approximately 32 km/h (20 MPH) and when a vehicle ahead is detected.
2. Check that the set speed increases by 1 km/h (1 MPH) as RESUME/ACCELERATE switch is pushed up.

### NOTE:

The maximum set speed of the vehicle-to-vehicle distance control mode is 144 km/h (90 MPH).

### CAUTION:

**Never set the cruise speed exceeding the posted speed limit.**

>> GO TO 9.

## 9.CHECK FOR DECREASE OF CRUISING SPEED INSPECTION (2)

1. Set the vehicle-to-vehicle distance control mode when the vehicle speed is less than approximately 32 km/h (20 MPH) and when a vehicle ahead is detected.
2. Set the set vehicle speed to the desired vehicle speed according to “check for increase of cruising speed”.
3. Check that the set speed decreases by 1 km/h (1 MPH) as SET/COAST switch is pushed down.

### NOTE:

- The minimum the set speed is approximately 32 km/h (20 MPH).
- If the vehicle ahead comes to a stop, the vehicle decelerates to a standstill within the limitations of the system. The system will cancel once it judges a standstill with a warning chime.

### CAUTION:

**The creep occurs because the stop status is not maintained.**

>> GO TO 10.

## 10.CHECK FOR CANCELLATION OF VEHICLE-TO-VEHICLE DISTANCE CONTROL MODE

Check that the vehicle-to-vehicle distance control mode is canceled when performing the following operations.

- When the brake pedal is depressed after vehicle-to-vehicle distance control mode is set and the vehicle is driven.
- When the selector lever is in the “N” position after vehicle-to-vehicle distance control mode is set and the vehicle is driven.
- When the MAIN switch is turned OFF after vehicle-to-vehicle distance control mode is set and the vehicle is driven.
- When the CANCEL switch is pressed after vehicle-to-vehicle distance control mode is set and the vehicle is driven.

>> GO TO 11.

A  
B  
C  
D  
E  
F  
G  
H  
I  
J  
K  
L  
M  
N

CCS

P

# ACTION TEST

< BASIC INSPECTION >

[ICC]

## 11. CHECK FOR RESTORING SPEED THAT IS SET BY VEHICLE-TO-VEHICLE DISTANCE CONTROL MODE BEFORE CANCELLATION

Check that the vehicle restores the previous speed kept before the system deactivation when performing the following operations.

- Drive the vehicle when the vehicle-to-vehicle distance control mode is set and depress the brake pedal to cancel the control. Check that the vehicle restores the previous vehicle speed kept before the system deactivation when pushing up the RESUME/ACCELERATE switch.
- Drive the vehicle when the vehicle-to-vehicle distance control mode is set and shift the selector lever to the "N" position to cancel the control. Check that the vehicle restores the previous vehicle speed kept before the system deactivation when shifting the selector lever to the "D" position and pushing up the RESUME/ACCELERATE switch.
- Drive the vehicle when the vehicle-to-vehicle distance control mode is set and press the CANCEL switch to cancel the control. Check that the vehicle restores the previous vehicle speed kept before the system deactivation when pushing up the RESUME/ACCELERATE switch.

>> INSPECTION END

## Work Procedure [Conventional (Fixed Speed) Cruise Control Mode]

INFOID:000000009644240

### NOTE:

The running speed can be set between 40 km/h (25 MPH) and 144 km/h (90 MPH)

### CAUTION:

**Never set the cruise speed exceeding the posted speed limit.**

## 1. CHECK FOR MAIN SWITCH

1. Start the engine.
2. Press the MAIN switch ① (1.5 seconds or more).

Information display status	
MAIN switch indicator ②	: ON
Set vehicle speed indicator ③	: " _ _ _ "
	: "km/h" ("MPH")

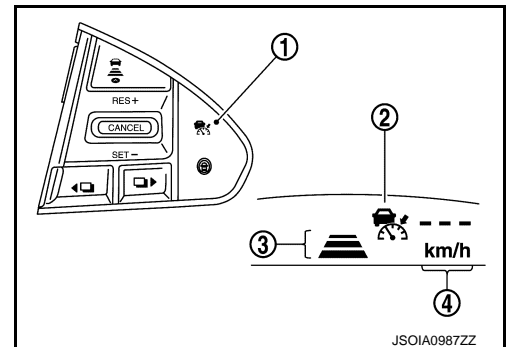

3. Check that the ICC system display on the information display turns on and the display is ready for activation.
4. Press the MAIN switch, and check that the ICC system display on the information display turns OFF when the ICC system is deactivated.
5. Check that the ICC system display on the information display turns OFF after starting the engine again.

>> GO TO 2.

## 2. CHECK FOR RESUME/ACCELERATE, SET/COAST, AND CANCEL SWITCHES

1. Check that RESUME/ACCELERATE, SET/COAST, CANCEL switches are operated smoothly.
2. Check that switches come up as hand is released from the switches.

>> GO TO 3.

## 3. SET CHECKING

1. Start the engine.
2. Press the MAIN switch (1.5 seconds or more) and turn the conventional (fixed speed) cruise control mode to ON.
3. Drive the vehicle at 40 km/h (25 MPH) or more.
4. Push down the SET/COAST switch.

# ACTION TEST

< BASIC INSPECTION >

[ICC]

5. Check that the desired speed is set and conventional (fixed speed) cruise control mode control starts when releasing SET/COAST switch.

**NOTE:**

- The set vehicle speed is not displayed in the ICC system display on the information display.
- Display the set status in the ICC system display on the information display.

>> GO TO 4.

## 4.CHECK FOR INCREASE OF CRUISING SPEED

1. Set the vehicle speed to any desired speed, and drive the vehicle.
2. Check that the set speed increases by 1.6 km/h (1 MPH) as RESUME/ACCELERATE switch is pushed up.

**NOTE:**

- The maximum set speed is 144 km/h (90 MPH).
- The set vehicle speed increases while pushing up the RESUME/ACCELERATE switch.

**CAUTION:**

**Never set the cruise speed exceeding the posted speed limit.**

>> GO TO 5.

## 5.CHECK FOR DECREASE OF CRUISING SPEED

1. Set the vehicle speed to any desired speed, and drive the vehicle.
2. Check that the set speed decreases by 1.6 km/h (1 MPH) as SET/COAST switch is pushed down.

**NOTE:**

- The minimum set speed is 40 km/h (25 MPH).
- The set vehicle speed decreases while pressing down the SET/COAST switch.

>> GO TO 6.

## 6.CHECK FOR CANCELLATION OF CONVENTIONAL (FIXED SPEED) CRUISE CONTROL MODE

Check that the conventional (fixed speed) cruise control mode is canceled when performing the following operations.

- When the brake pedal is depressed after the conventional (fixed speed) cruise control mode is set and the vehicle is driven.
- When the selector lever is in the "N" position after the conventional (fixed speed) cruise control mode is set and the vehicle is driven.
- When the MAIN switch is turned OFF after the conventional (fixed speed) cruise control mode is set and the vehicle is driven.
- When the CANCEL switch is pressed after the conventional (fixed speed) cruise control mode is set and the vehicle is driven.

>> GO TO 7.

## 7.CHECK FOR RESTORING SPEED THAT IS SET BY CONVENTIONAL (FIXED SPEED) CRUISE CONTROL MODE BEFORE CANCELLATION

Check that the vehicle restores the previous speed kept before the system deactivation when performing the following operations.

- Drive the vehicle when the conventional (fixed speed) cruise control mode is set and depress the brake pedal to cancel the control. Check that the vehicle restores the previous vehicle speed kept before the system deactivation when pushing up the RESUME/ACCELERATE switch at the vehicle speed approximately 40 km/h (25 MPH) or more.
- Drive the vehicle when the conventional (fixed speed) cruise control mode is set and shift the selector lever is in the "N" position to cancel the control. Check that the vehicle restores the previous vehicle speed kept before the system deactivation when shifting the selector lever is in the "D" position and pushing up the RESUME/ACCELERATE switch at the vehicle speed of approximately 40 km/h (25 MPH) or more.
- Drive the vehicle when the conventional (fixed speed) cruise control mode is set and press the CANCEL switch to cancel the control. Check that the vehicle restores the previous vehicle speed kept before the system deactivation when pushing up the RESUME/ACCELERATE switch at the vehicle speed of approximately 40 km/h (25 MPH) or more.

# ACTION TEST

< BASIC INSPECTION >

[ICC]

---

>> INSPECTION END

# DTC/CIRCUIT DIAGNOSIS

## C1A00 CONTROL UNIT

### DTC Logic

INFOID:000000009644241

### DTC DETECTION LOGIC

DTC	Trouble diagnosis name	DTC detecting condition
C1A00	CONTROL UNIT (Control unit malfunction)	ICC sensor internal malfunction

### POSSIBLE CAUSE

ICC sensor

### FAIL-SAFE

The following systems are canceled.

- Vehicle-to-vehicle distance control mode
- Conventional (fixed speed) cruise control mode
- Distance Control Assist (DCA)
- Forward Emergency Braking (FEB)
- Predictive Forward Collision Warning (PFCW)

### DTC CONFIRMATION PROCEDURE

#### 1. PERFORM DTC CONFIRMATION PROCEDURE

1. Start the engine.
2. Perform "All DTC Reading" with CONSULT.
3. Check if the "C1A00" is detected as the current malfunction in "Self Diagnostic Result" of "LASER/RADAR".

#### Is "C1A00" detected as the current malfunction?

- YES >> Refer to [CCS-101, "Diagnosis Procedure"](#).
- NO-1 >> To check malfunction symptom before repair: Refer to [GI-43, "Intermittent Incident"](#).
- NO-2 >> Confirmation after repair: INSPECTION END

### Diagnosis Procedure

INFOID:000000009644242

#### 1. CHECK SELF-DIAGNOSIS RESULTS

Check if any DTC other than "C1A00" is detected in "Self Diagnostic Result" of "LASER/RADAR".

#### Is any DTC detected?

- YES >> Perform diagnosis on the detected DTC and repair or replace the malfunctioning parts. Refer to [CCS-63, "DTC Index"](#).
- NO >> Replace the ICC sensor. Refer to [CCS-135, "Removal and Installation"](#).

# C1A01 POWER SUPPLY CIRCUIT 1, C1A02 POWER SUPPLY CIRCUIT 2

< DTC/CIRCUIT DIAGNOSIS >

[ICC]

## C1A01 POWER SUPPLY CIRCUIT 1, C1A02 POWER SUPPLY CIRCUIT 2

### DTC Logic

INFOID:000000009644243

### DTC DETECTION LOGIC

DTC	Trouble diagnosis name	DTC detecting condition
C1A01	POWER SUPPLY CIR (Power supply circuit)	The battery voltage sent to ICC sensor remains less than 7.9 V for 5 seconds
C1A02	POWER SUPPLY CIR 2 (Power supply circuit 2)	The battery voltage sent to ICC sensor remains more than 19.3 V for 5 seconds

### POSSIBLE CAUSE

- Connector, harness, fuse
- ICC sensor

### FAIL-SAFE

The following systems are canceled.

- Vehicle-to-vehicle distance control mode
- Conventional (fixed speed) cruise control mode
- Distance Control Assist (DCA)
- Forward Emergency Braking (FEB)
- Predictive Forward Collision Warning (PFCW)

### DTC CONFIRMATION PROCEDURE

#### 1. PERFORM DTC CONFIRMATION PROCEDURE

1. Start the engine.
2. Turn the MAIN switch of ICC system ON.
3. Perform "All DTC Reading" with CONSULT.
4. Check if the "C1A01" or "C1A02" is detected as the current malfunction in "Self Diagnostic Result" of "LASER/RADAR".

Is "C1A01" or "C1A02" detected as the current malfunction?

YES >> Refer to [CCS-102, "Diagnosis Procedure"](#).

NO-1 >> To check malfunction symptom before repair: Refer to [GI-43, "Intermittent Incident"](#).

NO-2 >> Confirmation after repair: INSPECTION END

### Diagnosis Procedure

INFOID:000000009644244

#### 1. CHECK ICC SENSOR POWER SUPPLY AND GROUND CIRCUIT

Check power supply and ground circuit of ICC sensor. Refer to [CCS-118, "Diagnosis Procedure"](#).

Is the inspection result normal?

YES >> Replace the ICC sensor. Refer to [CCS-135, "Removal and Installation"](#).

NO >> Repair or replace the malfunctioning parts.

# C1A12 RADAR OFF-CENTER

< DTC/CIRCUIT DIAGNOSIS >

[ICC]

## C1A12 RADAR OFF-CENTER

### DTC Logic

INFOID:000000009644245

### DTC DETECTION LOGIC

DTC	Trouble diagnosis name	DTC detecting condition
C1A12	RADAR OFF-CENTER (Radar off-center)	Radar of ICC sensor is off the aiming point

### POSSIBLE CAUSE

Radar is off the aiming point

### FAIL-SAFE

The following systems are canceled.

- Vehicle-to-vehicle distance control mode
- Distance Control Assist (DCA)
- Forward Emergency Braking (FEB)
- Predictive Forward Collision Warning (PFCW)

### DTC CONFIRMATION PROCEDURE

#### 1. PERFORM DTC CONFIRMATION PROCEDURE

1. Start the engine.
2. Turn the MAIN switch of ICC system ON.
3. Perform "All DTC Reading" with CONSULT.
4. Check if the "C1A12" is detected as the current malfunction in "Self Diagnostic Result" of "LASER/RADAR".

#### Is "C1A12" detected as the current malfunction?

- YES >> Refer to [CCS-103, "Diagnosis Procedure"](#).
- NO-1 >> To check malfunction symptom before repair: Refer to [GI-43, "Intermittent Incident"](#).
- NO-2 >> Confirmation after repair: INSPECTION END

### Diagnosis Procedure

INFOID:000000009644246

#### 1. ADJUST RADAR AIMING

1. Adjust the radar beam aiming with CONSULT. Refer to [CCS-83, "TYPE 1 : Description"](#).
2. Perform "All DTC Reading".
3. Check if the "C1A12" is detected in "Self Diagnostic Result" of "LASER/RADAR".

#### Is "C1A12" detected?

- YES >> Replace the ICC sensor. Refer to [CCS-135, "Removal and Installation"](#).
- NO >> INSPECTION END

A  
B  
C  
D  
E  
F  
G  
H  
I  
J  
K  
L  
M  
N  
P

CCS

# C1A16 RADAR BLOCKED

< DTC/CIRCUIT DIAGNOSIS >

[ICC]

## C1A16 RADAR BLOCKED

### DTC Logic

INFOID:000000009644247

### DTC DETECTION LOGIC

DTC	Trouble diagnosis name	DTC detecting condition
C1A16	RADAR BLOCKED (Radar blocked)	Inclusion of dirt or stains on the ICC sensor area of the front bumper

#### NOTE:

DTC "C1A16" may be detected under the following conditions. (Explain to the customer about the difference between the contamination detection function and the indication when the malfunction is detected and tell them "This is not malfunction".)

- When contamination or foreign materials adhere to the ICC sensor area of the front bumper
- When driving while it is snowing or when frost forms on the ICC sensor area of the front bumper
- When ICC sensor area of the front bumper is temporarily fogged

#### POSSIBLE CAUSE

- Stain or foreign materials is deposited
- Cracks or scratches exist

#### FAIL-SAFE

The following systems are canceled.

- Vehicle-to-vehicle distance control mode
- Distance Control Assist (DCA)
- Forward Emergency Braking (FEB)
- Predictive Forward Collision Warning (PFCW)

#### DTC CONFIRMATION PROCEDURE

##### 1. PERFORM DTC CONFIRMATION PROCEDURE

1. Start the engine.
2. Turn the MAIN switch of ICC system ON.
3. Perform "All DTC Reading" with CONSULT.
4. Check if the "C1A16" is detected as the current malfunction in "Self Diagnostic Result" of "LASER/RADAR".

Is "C1A16" detected as the current malfunction?

- YES >> Refer to [CCS-104, "Diagnosis Procedure"](#).  
NO-1 >> To check malfunction symptom before repair: Refer to [GI-43, "Intermittent Incident"](#).  
NO-2 >> Confirmation after repair: INSPECTION END

#### Diagnosis Procedure

INFOID:000000009644248

##### 1. VISUAL CHECK 1

Check the contamination and foreign matter on the ICC sensor area of the front bumper.

Does contamination or foreign materials adhere?

- YES >> Wipe out the contamination and foreign matter on the ICC sensor area of the front bumper.  
NO >> GO TO 2.

##### 2. VISUAL CHECK 2

1. Remove the front bumper. Refer to [EXT-14, "Removal and Installation"](#).
2. Check ICC sensor for contamination and foreign matter.

Does contamination or foreign matter adhere?

- YES >> Wipe out the contamination and foreign matter from the ICC sensor.  
NO >> GO TO 3.

##### 3. VISUAL CHECK 3

Check ICC sensor for cracks and scratches.



# C1A16 RADAR BLOCKED

< DTC/CIRCUIT DIAGNOSIS >

[ICC]

Is it found?

- YES >> Replace the ICC sensor. Refer to [CCS-135, "Removal and Installation"](#).
- NO >> GO TO 4.

A

## 4. INTERVIEW

1. Ask if there is any trace of contamination or foreign materials adhering to the ICC sensor area of the front bumper.
2. Ask if ICC sensor area of the front bumper was frosted during driving or if vehicle was driven in snow.
3. Ask if ICC sensor area of the front bumper was temporarily fogged. (Windshield glass may also tend to fog, etc.)

B

C

Is any of above conditions seen?

- YES >> Explain to the customer about the difference between the contamination detection function and the indication when the malfunction is detected and tell them "This is not malfunction".
- NO >> Replace the ICC sensor. Refer to [CCS-135, "Removal and Installation"](#).

D

E

F

G

H

I

J

K

L

M

N

CCS

P

## C1A21 UNIT HIGH TEMP

### DTC Logic

INFOID:000000009644251

### DTC DETECTION LOGIC

DTC	Trouble diagnosis name	DTC detecting condition
C1A21	UNIT HIGH TEMP (Unit high temperature)	Temperature detected by the temperature sensor integrated in ICC sensor remains more than 105 °C (221 °F) for 5 seconds or more

### POSSIBLE CAUSE

Temperature around the ICC sensor becomes extremely low or high

### FAIL-SAFE

The following systems are canceled.

- Vehicle-to-vehicle distance control mode
- Conventional (fixed speed) cruise control mode
- Distance Control Assist (DCA)
- Forward Emergency Braking (FEB)
- Predictive Forward Collision Warning (PFCW)

### DTC CONFIRMATION PROCEDURE

#### 1. PERFORM DTC CONFIRMATION PROCEDURE

1. Turn the ignition switch OFF.
2. Wait for 10 minutes or more.
3. Start the engine.
4. Turn the MAIN switch of ICC system ON.
5. Perform "All DTC Reading" with CONSULT.
6. Check if the "C1A21" is detected as the current malfunction in "Self Diagnostic Result" of "LASER/RADAR".

Is "C1A21" detected as the current malfunction?

- YES >> Refer to [CCS-106. "Diagnosis Procedure"](#).  
 NO-1 >> To check malfunction symptom before repair: Refer to [GI-43. "Intermittent Incident"](#).  
 NO-2 >> Confirmation after repair: INSPECTION END

### Diagnosis Procedure

INFOID:000000009644252

#### 1. CHECK ENGINE COOLING SYSTEM

Check for any malfunctions in engine cooling system.

Is engine cooling system normal?

- YES >> Replace the ICC sensor. Refer to [CCS-135. "Removal and Installation"](#).  
 NO >> Repair engine cooling system.

# C1A23 UNIT LOW TEMP

< DTC/CIRCUIT DIAGNOSIS >

[ICC]

## C1A23 UNIT LOW TEMP

### DTC Logic

INFOID:000000009731493

### DTC DETECTION LOGIC

DTC	Trouble diagnosis name	DTC detecting condition
C1A23	UNIT LOW TEMP (Unit low temperature)	Temperature detected by the temperature sensor integrated in ICC sensor remains less than -45 °C (-49 °F) for 5 seconds or more

### POSSIBLE CAUSE

Temperature around the ICC sensor becomes extremely low or high

### FAIL-SAFE

The following systems are canceled.

- Vehicle-to-vehicle distance control mode
- Conventional (fixed speed) cruise control mode
- Distance Control Assist (DCA)
- Forward Emergency Braking (FEB)
- Predictive Forward Collision Warning (PFCW)

### DTC CONFIRMATION PROCEDURE

#### 1. PERFORM DTC CONFIRMATION PROCEDURE

1. Turn the ignition switch OFF.
2. Wait for 10 minutes or more.
3. Start the engine.
4. Turn the MAIN switch of ICC system ON.
5. Perform "All DTC Reading" with CONSULT.
6. Check if the "C1A23" is detected as the current malfunction in "Self Diagnostic Result" of "LASER/RADAR".

Is "C1A23" detected as the current malfunction?

YES >> Refer to [CCS-107, "Diagnosis Procedure"](#).

NO-1 >> To check malfunction symptom before repair: Refer to [GI-43, "Intermittent Incident"](#).

NO-2 >> Confirmation after repair: INSPECTION END

### Diagnosis Procedure

INFOID:000000009731494

#### 1. CHECK ENVIRONMENT CONDITION

Check ambient temperature.

Is ambient temperature 0°C (32°F) or more?

YES >> Replace the ICC sensor. Refer to [CCS-135, "Removal and Installation"](#).

NO >> Perform check again at 0°C (32°F) or more.

A  
B  
C  
D  
E  
F  
G  
H  
I  
J  
K  
L  
M  
N  
P

CCS

# C1A39 STEERING ANGLE SENSOR

< DTC/CIRCUIT DIAGNOSIS >

[ICC]

## C1A39 STEERING ANGLE SENSOR

### DTC Logic

INFOID:000000009644253

### DTC DETECTION LOGIC

DTC	Trouble diagnosis name	DTC detecting condition
C1A39	STRG SEN CIR (Steering angle sensor circuit)	If the steering angle sensor is malfunction

### POSSIBLE CAUSE

Steering angle sensor

### FAIL-SAFE

The following systems are canceled.

- Vehicle-to-vehicle distance control mode
- Conventional (fixed speed) cruise control mode
- Distance Control Assist (DCA)
- Forward Emergency Braking (FEB)
- Predictive Forward Collision Warning (PFCW)

### DTC CONFIRMATION PROCEDURE

#### 1.CHECK DTC PRIORITY

If DTC "C1A39" is displayed with DTC "U1000", first diagnose the DTC "U1000".

Is applicable DTC detected?

- YES >> Perform diagnosis of applicable. Refer to [DAS-128, "DTC Logic"](#).  
NO >> GO TO 2.

#### 2.PERFORM DTC CONFIRMATION PROCEDURE

1. Start the engine.
2. Turn the MAIN switch of ICC system ON.
3. Perform "All DTC Reading" with CONSULT.
4. Check if the "C1A39" is detected as the current malfunction in self-diagnosis results of "LASER/RADAR".

Is "C1A39" detected as the current malfunction?

- YES >> Refer to [CCS-108, "Diagnosis Procedure"](#).  
NO-1 >> To check malfunction symptom before repair: Refer to [GI-43, "Intermittent Incident"](#).  
NO-2 >> Confirmation after repair: INSPECTION END

### Diagnosis Procedure

INFOID:000000009644254

#### 1.CHECK DTC PRIORITY

If DTC "C1A39" is displayed with DTC "U1000", first diagnose the DTC "U1000".

Is applicable DTC detected?

- YES >> Perform diagnosis of applicable. Refer to [DAS-128, "DTC Logic"](#).  
NO >> GO TO 2.

#### 2.CHECK ADAS CONTROL UNIT SELF-DIAGNOSIS RESULTS

Check if any DTC is detected in "Self Diagnostic Result" of "ICC/ADAS".

Is any DTC detected?

- YES >> Perform diagnosis on the detected DTC and repair or replace the malfunctioning parts. Refer to [CCS-58, "DTC Index"](#).  
NO >> Replace the ICC sensor. Refer to [CCS-135, "Removal and Installation"](#).

# C1A50 ADAS CONTROL UNIT

< DTC/CIRCUIT DIAGNOSIS >

[ICC]

## C1A50 ADAS CONTROL UNIT

### DTC Logic

INFOID:000000009644255

### DTC DETECTION LOGIC

DTC	Trouble diagnosis name	DTC detecting condition
C1A50	ADAS MALFUNCTION (ADAS control unit malfunction)	If ADAS control unit is malfunctioning

### POSSIBLE CAUSE

ADAS control unit

### FAIL-SAFE

The following systems are canceled.

- Vehicle-to-vehicle distance control mode
- Conventional (fixed speed) cruise control mode
- Distance Control Assist (DCA)
- Forward Emergency Braking (FEB)
- Predictive Forward Collision Warning (PFCW)

### DTC CONFIRMATION PROCEDURE

#### 1. CHECK DTC PRIORITY

If DTC "C1A50" is displayed with DTC "U1000", first diagnose the DTC "U1000".

Is applicable DTC detected?

- YES >> Perform diagnosis of applicable. Refer to [CCS-116, "DTC Logic"](#).  
NO >> GO TO 2.

#### 2. PERFORM DTC CONFIRMATION PROCEDURE

1. Start the engine.
2. Turn the MAIN switch of ICC system ON.
3. Perform "All DTC Reading" with CONSULT.
4. Check if the "C1A50" is detected as the current malfunction in "Self Diagnostic Result" of "LASER/RADAR".

Is "C1A50" detected as the current malfunction?

- YES >> Refer to [CCS-109, "Diagnosis Procedure"](#).  
NO-1 >> To check malfunction symptom before repair: Refer to [GI-43, "Intermittent Incident"](#).  
NO-2 >> Confirmation after repair: INSPECTION END

### Diagnosis Procedure

INFOID:000000009644256

#### 1. CHECK DTC PRIORITY

If DTC "C1A50" is displayed with DTC "U1000", first diagnose the DTC "U1000".

Is applicable DTC detected?

- YES >> Perform diagnosis of applicable. Refer to [CCS-116, "DTC Logic"](#).  
NO >> GO TO 2.

#### 2. CHECK ADAS CONTROL UNIT SELF-DIAGNOSIS RESULTS

Check if any DTC is detected in "Self Diagnostic Result" of "ICC/ADAS".

Is any DTC detected?

- YES >> Perform diagnosis on the detected DTC and repair or replace the malfunctioning parts. Refer to [CCS-58, "DTC Index"](#).  
NO >> Replace the ICC sensor. Refer to [CCS-135, "Removal and Installation"](#).

A  
B  
C  
D  
E  
F  
G  
H  
I  
J  
K  
L  
M  
N  
P

CCS

## U0104 ADAS CAN 1

### DTC Logic

INFOID:000000009644257

### DTC DETECTION LOGIC

DTC	Trouble diagnosis name	DTC detecting condition
U0104	ADAS CAN CIR 1 (ADAS control unit CAN circuit 1)	If ICC sensor detects an error signal that is received from ADAS control unit via ITS communication

### POSSIBLE CAUSE

ADAS control unit

### FAIL-SAFE

The following systems are canceled.

- Vehicle-to-vehicle distance control mode
- Conventional (fixed speed) cruise control mode
- Distance Control Assist (DCA)
- Forward Emergency Braking (FEB)
- Predictive Forward Collision Warning (PFCW)

### DTC CONFIRMATION PROCEDURE

#### 1.CHECK DTC PRIORITY

If DTC "U0104" is displayed with DTC "U1000", first diagnose the DTC "U1000".

Is applicable DTC detected?

- YES >> Perform diagnosis of applicable. Refer to [CCS-116, "DTC Logic"](#).  
 NO >> GO TO 2.

#### 2.PERFORM DTC CONFIRMATION PROCEDURE

1. Start the engine.
2. Turn the MAIN switch of ICC system ON.
3. Perform "All DTC Reading" with CONSULT.
4. Check if the "U0104" is detected as the current malfunction in "Self Diagnostic Result" of "LASER/RADAR".

Is "U0104" detected as the current malfunction?

- YES >> Refer to [CCS-110, "Diagnosis Procedure"](#).  
 NO-1 >> To check malfunction symptom before repair: Refer to [GI-43, "Intermittent Incident"](#).  
 NO-2 >> Confirmation after repair: INSPECTION END

### Diagnosis Procedure

INFOID:000000009644258

#### 1.CHECK DTC PRIORITY

If DTC "U0104" is displayed with DTC "U1000", first diagnose the DTC "U1000".

Is applicable DTC detected?

- YES >> Perform diagnosis of applicable. Refer to [CCS-116, "DTC Logic"](#).  
 NO >> GO TO 2.

#### 2.CHECK ADAS CONTROL UNIT SELF-DIAGNOSIS RESULTS

Check if any DTC is detected in "Self Diagnostic Result" of "ICC/ADAS".

Is any DTC detected?

- YES >> Perform diagnosis on the detected DTC and repair or replace the malfunctioning parts. Refer to [CCS-58, "DTC Index"](#).  
 NO >> Replace the ICC sensor. Refer to [CCS-135, "Removal and Installation"](#).

U0121 VDC CAN 2

DTC Logic

INFOID:000000009644259

DTC DETECTION LOGIC

DTC	Trouble diagnosis name	DTC detecting condition
U0121	VDC CAN CIR2 (VDC CAN circuit2)	If ICC sensor detects an error signal that is received from ABS actuator and electric unit (control unit) via ADAS control unit

POSSIBLE CAUSE

ABS actuator and electric unit (control unit)

FAIL-SAFE

The following systems are canceled.

- Vehicle-to-vehicle distance control mode
- Conventional (fixed speed) cruise control mode
- Distance Control Assist (DCA)
- Forward Emergency Braking (FEB)
- Predictive Forward Collision Warning (PFCW)

DTC CONFIRMATION PROCEDURE

1.CHECK DTC PRIORITY

If DTC “U0121” is displayed with DTC “U1000”, first diagnose the DTC “U1000”.

Is applicable DTC detected?

- YES >> Perform diagnosis of applicable. Refer to [CCS-116. "DTC Logic"](#).
- NO >> GO TO 2.

2.PERFORM DTC CONFIRMATION PROCEDURE

1. Start the engine.
2. Turn the MAIN switch of ICC system ON.
3. Perform “All DTC Reading” with CONSULT.
4. Check if the “U0121” is detected as the current malfunction in “Self Diagnostic Result” of “LASER/RADAR”.

Is “U0121” detected as the current malfunction?

- YES >> Refer to [CCS-111. "Diagnosis Procedure"](#).
- NO-1 >> To check malfunction symptom before repair: Refer to [GI-43. "Intermittent Incident"](#).
- NO-2 >> Confirmation after repair: INSPECTION END

Diagnosis Procedure

INFOID:000000009644260

1.CHECK DTC PRIORITY

If DTC “U0121” is displayed with DTC “U1000”, first diagnose the DTC “U1000”.

Is applicable DTC detected?

- YES >> Perform diagnosis of applicable. Refer to [CCS-116. "DTC Logic"](#).
- NO >> GO TO 2.

2.CHECK ADAS CONTROL UNIT SELF-DIAGNOSIS RESULTS

Check if any DTC is detected in “Self Diagnostic Result” of “ICC/ADAS”.

Is any DTC detected?

- YES >> Perform diagnosis on the detected DTC and repair or replace the malfunctioning parts. Refer to [CCS-58. "DTC Index"](#).
- NO >> Replace the ICC sensor. Refer to [CCS-135. "Removal and Installation"](#).

A  
B  
C  
D  
E  
F  
G  
H  
I  
J  
K  
L  
M  
N  
P



## U0126 STRG SEN CAN 1

### DTC Logic

INFOID:000000009644261

### DTC DETECTION LOGIC

DTC	Trouble diagnosis name	DTC detecting condition
U0126	STRG SEN CAN CIR1 (Steering angle sensor CAN circuit1)	If ICC sensor detects an error signal that is received from steering angle sensor via ADAS control unit

### POSSIBLE CAUSE

Steering angle sensor error

### FAIL-SAFE

The following systems are canceled.

- Vehicle-to-vehicle distance control mode
- Conventional (fixed speed) cruise control mode
- Distance Control Assist (DCA)
- Forward Emergency Braking (FEB)
- Predictive Forward Collision Warning (PFCW)

### DTC CONFIRMATION PROCEDURE

#### 1.CHECK DTC PRIORITY

If DTC "U0126" is displayed with DTC "U1000", first diagnose the DTC "U1000".

Is applicable DTC detected?

- YES >> Perform diagnosis of applicable. Refer to [CCS-116. "DTC Logic"](#).  
 NO >> GO TO 2.

#### 2.PERFORM DTC CONFIRMATION PROCEDURE

1. Start the engine.
2. Turn the MAIN switch of ICC system ON.
3. Perform "All DTC Reading" with CONSULT.
4. Check if the "U0126" is detected as the current malfunction in "Self Diagnostic Result" of "LASER/RADAR".

Is "U0126" detected as the current malfunction?

- YES >> Refer to [CCS-112. "Diagnosis Procedure"](#).  
 NO-1 >> To check malfunction symptom before repair: Refer to [GI-43. "Intermittent Incident"](#).  
 NO-2 >> Confirmation after repair: INSPECTION END

### Diagnosis Procedure

INFOID:000000009644262

#### 1.CHECK DTC PRIORITY

If DTC "U0126" is displayed with DTC "U1000", first diagnose the DTC "U1000".

Is applicable DTC detected?

- YES >> Perform diagnosis of applicable. Refer to [CCS-116. "DTC Logic"](#).  
 NO >> GO TO 2.

#### 2.CHECK ADAS CONTROL UNIT SELF-DIAGNOSIS RESULTS

Check if any DTC is detected in "Self Diagnostic Result" of "ICC/ADAS".

Is any DTC detected?

- YES >> Perform diagnosis on the detected DTC and repair or replace the malfunctioning parts. Refer to [CCS-58. "DTC Index"](#).  
 NO >> Replace the ICC sensor. Refer to [CCS-135. "Removal and Installation"](#).



U0405 ADAS CAN 2

DTC Logic

INFOID:000000009644263

DTC DETECTION LOGIC

DTC	Trouble diagnosis name	DTC detecting condition
U0405	ADAS CAN CIR 2 (ADAS control unit CAN circuit 2)	If ICC sensor detects an error signal that is received from ADAS control unit via ITS communication

POSSIBLE CAUSE

ADAS control unit

FAIL-SAFE

The following systems are canceled.

- Vehicle-to-vehicle distance control mode
- Conventional (fixed speed) cruise control mode
- Distance Control Assist (DCA)
- Forward Emergency Braking (FEB)
- Predictive Forward Collision Warning (PFCW)

DTC CONFIRMATION PROCEDURE

1.CHECK DTC PRIORITY

If DTC “U0405” is displayed with DTC “U1000”, first diagnose the DTC “U1000”.

Is applicable DTC detected?

- YES >> Perform diagnosis of applicable. Refer to [CCS-116. "DTC Logic"](#).
- NO >> GO TO 2.

2.PERFORM DTC CONFIRMATION PROCEDURE

1. Start the engine.
2. Turn the MAIN switch of ICC system ON.
3. Perform “All DTC Reading” with CONSULT.
4. Check if the “U0405” is detected as the current malfunction in “Self Diagnostic Result” of “LASER/RADAR”.

Is “U0405” detected as the current malfunction?

- YES >> Refer to [CCS-113. "Diagnosis Procedure"](#).
- NO-1 >> To check malfunction symptom before repair: Refer to [GI-43. "Intermittent Incident"](#).
- NO-2 >> Confirmation after repair: INSPECTION END

Diagnosis Procedure

INFOID:000000009644264

1.CHECK DTC PRIORITY

If DTC “U0405” is displayed with DTC “U1000”, first diagnose the DTC “U1000”.

Is applicable DTC detected?

- YES >> Perform diagnosis of applicable. Refer to [CCS-116. "DTC Logic"](#).
- NO >> GO TO 2.

2.CHECK ADAS CONTROL UNIT SELF-DIAGNOSIS RESULTS

Check if any DTC is detected in “Self Diagnostic Result” of “ICC/ADAS”.

Is any DTC detected?

- YES >> Perform diagnosis on the detected DTC and repair or replace the malfunctioning parts. Refer to [CCS-58. "DTC Index"](#).
- NO >> Replace the ICC sensor. Refer to [CCS-135. "Removal and Installation"](#).

A  
B  
C  
D  
E  
F  
G  
H  
I  
J  
K  
L  
M  
N  
P



## U0415 VDC CAN 1

### DTC Logic

INFOID:000000009644265

#### DTC DETECTION LOGIC

DTC	Trouble diagnosis name	DTC detecting condition
U0415	VDC CAN CIR1 (VDC CAN circuit1)	If ICC sensor detects an error signal that is received from ABS actuator and electric unit (control unit) via ADAS control unit

#### POSSIBLE CAUSE

ABS actuator and electric unit (control unit)

#### FAIL-SAFE

The following systems are canceled.

- Vehicle-to-vehicle distance control mode
- Conventional (fixed speed) cruise control mode
- Distance Control Assist (DCA)
- Forward Emergency Braking (FEB)
- Predictive Forward Collision Warning (PFCW)

#### DTC CONFIRMATION PROCEDURE

##### 1. CHECK DTC PRIORITY

If DTC "U0415" is displayed with DTC "U1000", first diagnose the DTC "U1000".

Is applicable DTC detected?

- YES >> Perform diagnosis of applicable. Refer to [CCS-116, "DTC Logic"](#).  
 NO >> GO TO 2.

##### 2. PERFORM DTC CONFIRMATION PROCEDURE

1. Start the engine.
2. Turn the MAIN switch of ICC system ON.
3. Perform "All DTC Reading" with CONSULT.
4. Check if the "U0415" is detected as the current malfunction in "Self Diagnostic Result" of "LASER/RADAR".

Is "U0415" detected as the current malfunction?

- YES >> Refer to [CCS-114, "Diagnosis Procedure"](#).  
 NO-1 >> To check malfunction symptom before repair: Refer to [GI-43, "Intermittent Incident"](#).  
 NO-2 >> Confirmation after repair: INSPECTION END

#### Diagnosis Procedure

INFOID:000000009644266

##### 1. CHECK DTC PRIORITY

If DTC "U0415" is displayed with DTC "U1000", first diagnose the DTC "U1000".

Is applicable DTC detected?

- YES >> Perform diagnosis of applicable. Refer to [CCS-116, "DTC Logic"](#).  
 NO >> GO TO 2.

##### 2. CHECK ADAS CONTROL UNIT SELF-DIAGNOSIS RESULTS

Check if any DTC is detected in "Self Diagnostic Result" of "ICC/ADAS".

Is any DTC detected?

- YES >> Perform diagnosis on the detected DTC and repair or replace the malfunctioning parts. Refer to [CCS-58, "DTC Index"](#).  
 NO >> Replace the ICC sensor. Refer to [CCS-135, "Removal and Installation"](#).

## U0428 STRG SEN CAN 2

### DTC Logic

INFOID:000000009644267

### DTC DETECTION LOGIC

DTC	Trouble diagnosis name	DTC detecting condition
U0428	STRG SEN CAN CIR2 (Steering angle sensor CAN circuit2)	If ICC sensor detects an error signal that is received from steering angle sensor via ADAS control unit

### POSSIBLE CAUSE

Steering angle sensor

### FAIL-SAFE

The following systems are canceled.

- Vehicle-to-vehicle distance control mode
- Conventional (fixed speed) cruise control mode
- Distance Control Assist (DCA)
- Forward Emergency Braking (FEB)
- Predictive Forward Collision Warning (PFCW)

### DTC CONFIRMATION PROCEDURE

#### 1. CHECK DTC PRIORITY

If DTC "U0428" is displayed with DTC "U1000", first diagnose the DTC "U1000".

Is applicable DTC detected?

YES >> Perform diagnosis of applicable. Refer to [CCS-116. "DTC Logic"](#).

NO >> GO TO 2.

#### 2. PERFORM DTC CONFIRMATION PROCEDURE

1. Start the engine.
2. Turn the MAIN switch of ICC system ON.
3. Perform "All DTC Reading" with CONSULT.
4. Check if the "U0428" is detected as the current malfunction in "Self Diagnostic Result" of "LASER/RADAR".

Is "U0428" detected as the current malfunction?

YES >> Refer to [CCS-115. "Diagnosis Procedure"](#).

NO-1 >> To check malfunction symptom before repair: Refer to [GI-43. "Intermittent Incident"](#).

NO-2 >> Confirmation after repair: INSPECTION END

### Diagnosis Procedure

INFOID:000000009644268

#### 1. CHECK DTC PRIORITY

If DTC "U0428" is displayed with DTC "U1000", first diagnose the DTC "U1000".

Is applicable DTC detected?

YES >> Perform diagnosis of applicable. Refer to [CCS-116. "DTC Logic"](#).

NO >> GO TO 2.

#### 2. CHECK ADAS CONTROL UNIT SELF-DIAGNOSIS RESULTS

Check if any DTC is detected in "Self Diagnostic Result" of "ICC/ADAS".

Is any DTC detected?

YES >> Perform diagnosis on the detected DTC and repair or replace the malfunctioning parts. Refer to [CCS-58. "DTC Index"](#).

NO >> Replace the ICC sensor. Refer to [CCS-135. "Removal and Installation"](#).



A  
B  
C  
D  
E  
F  
G  
H  
I  
J  
K  
L  
M  
N  
P

## U1000 CAN COMM CIRCUIT

### Description

INFOID:000000009644269

#### ITS COMMUNICATION

- ITS communication is a multiplex communication system. This enables the system to transmit and receive large quantities of data at high speed by connecting control units with 2 communication lines.
- ITS communication lines adopt twisted-pair line style (two lines twisted) for noise immunity.

### DTC Logic

INFOID:000000009644270

#### DTC DETECTION LOGIC

DTC	Trouble diagnosis name	DTC detecting condition
U1000	CAN COMM CIRCUIT (CAN communication circuit)	If ICC sensor is not transmitting or receiving ITS communication signal for 2 seconds or more

#### POSSIBLE CAUSE

ITS communication system

#### FAIL-SAFE

The following systems are canceled.

- Vehicle-to-vehicle distance control mode
- Conventional (fixed speed) cruise control mode
- Distance Control Assist (DCA)
- Forward Emergency Braking (FEB)
- Predictive Forward Collision Warning (PFCW)

#### DTC CONFIRMATION PROCEDURE

##### 1. PERFORM DTC CONFIRMATION PROCEDURE

1. Start the engine.
2. Turn the MAIN switch of ICC system ON.
3. Perform "All DTC Reading" with CONSULT.
4. Check if the "U1000" is detected as the current malfunction in "Self Diagnostic Result" of "ICC/ADAS".

##### Is "U1000" detected as the current malfunction?

- YES >> Refer to [CCS-116, "Diagnosis Procedure"](#).
- NO-1 >> To check malfunction symptom before repair: Refer to [GI-43, "Intermittent Incident"](#).
- NO-2 >> Confirmation after repair: INSPECTION END

### Diagnosis Procedure

INFOID:000000009644271

##### 1. PERFORM THE SELF-DIAGNOSIS

1. Turn the ignition switch ON.
2. Turn the MAIN switch of ICC system ON, and then wait for 2 seconds or more.
3. Perform "All DTC Reading" with CONSULT.
4. Check if the "U1000" is detected as the current malfunction in "Self Diagnostic Result" of "LASER/RADAR".

##### Is "U1000" detected as the current malfunction?

- YES >> Refer to [LAN-26, "Trouble Diagnosis Flow Chart"](#).
- NO >> INSPECTION END

# U1010 CONTROL UNIT (CAN)

< DTC/CIRCUIT DIAGNOSIS >

[ICC]

## U1010 CONTROL UNIT (CAN)

### Description

INFOID:000000009644272

CAN controller controls the communication of ITS communication signal and the error detection.

### DTC Logic

INFOID:000000009644273

### DTC DETECTION LOGIC

DTC	Trouble diagnosis name	DTC detecting condition
U1010	CONTROL UNIT (CAN) [Control unit (CAN)]	If ICC sensor detects malfunction by CAN controller initial diagnosis

### POSSIBLE CAUSE

ICC sensor

### FAIL-SAFE

The following systems are canceled.

- Vehicle-to-vehicle distance control mode
- Conventional (fixed speed) cruise control mode
- Distance Control Assist (DCA)
- Forward Emergency Braking (FEB)
- Predictive Forward Collision Warning (PFCW)

### DTC CONFIRMATION PROCEDURE

#### 1. PERFORM DTC CONFIRMATION PROCEDURE

1. Start the engine.
2. Turn the MAIN switch of ICC system ON.
3. Perform "All DTC Reading" with CONSULT.
4. Check if the "U1010" is detected as the current malfunction in "Self Diagnostic Result" of "ICC/ADAS".

Is "U1000" detected as the current malfunction?

YES >> Refer to [CCS-116, "Diagnosis Procedure"](#).

NO-1 >> To check malfunction symptom before repair: Refer to [GI-43, "Intermittent Incident"](#).

NO-2 >> Confirmation after repair: INSPECTION END

### Diagnosis Procedure

INFOID:000000009644274

#### 1. PERFORM DTC CONFIRMATION PROCEDURE

1. Turn the MAIN switch of ICC system ON.
2. Perform "All DTC Reading" with CONSULT.
3. Check if the "U1010" is detected as the current malfunction in "Self Diagnostic Result" of "LASER/RADAR".

Is "U1010" detected as the current malfunction?

YES >> Replace the ICC sensor. Refer to [CCS-135, "Removal and Installation"](#).

NO >> INSPECTION END

A  
B  
C  
D  
E  
F  
G  
H  
I  
J  
K  
L  
M  
N  
P

CCS

# POWER SUPPLY AND GROUND CIRCUIT

< DTC/CIRCUIT DIAGNOSIS >

[ICC]

## POWER SUPPLY AND GROUND CIRCUIT

### Diagnosis Procedure

INFOID:000000009644275

#### 1. CHECK FUSES

Check if any of the following fuses are blown:

Signal name	Fuse No.
Ignition power supply	54

Is the inspection result normal?

YES >> GO TO 2.

NO >> Replace the blown fuse after repairing the affected circuit if a fuse is blown.

#### 2. CHECK ICC SENSOR POWER SUPPLY CIRCUIT

Check voltage between ICC sensor harness connector and ground.

Terminal		Condition	Voltage (Approx.)
(+)	(-)		
ICC sensor		Ignition switch	0 V
Connector	Terminal		
E80	1	OFF	0 V
		ON	Battery voltage

Is the inspection result normal?

YES >> GO TO 3.

NO >> Repair the ICC sensor power supply circuit.

#### 3. CHECK ICC SENSOR GROUND CIRCUIT

1. Turn the ignition switch OFF.
2. Disconnect the ICC sensor connector.
3. Check for continuity between ICC sensor harness connector and ground.

ICC sensor		Ground	Continuity
Connector	Terminal		
E80	8		Existed

Is the inspection result normal?

YES >> INSPECTION END

NO >> Repair the ICC sensor ground circuit.

# INTELLIGENT CRUISE CONTROL SYSTEM SYMPTOMS

< SYMPTOM DIAGNOSIS >

[ICC]

## SYMPTOM DIAGNOSIS

### INTELLIGENT CRUISE CONTROL SYSTEM SYMPTOMS

#### Symptom Table

INFOID:000000009644276

Symptoms		Reference page
Operation	MAIN switch does not turn ON	Refer to <a href="#">CCS-120, "Description"</a>
	MAIN switch does not turn OFF	
	ICC system cannot be set (MAIN switch turns ON/OFF)	Refer to <a href="#">CCS-121, "Description"</a>
	CANCEL switch does not function	Refer to <a href="#">CCS-123, "Description"</a>
	Resume does not function	
	Set speed does not increase	
	Set distance to a vehicle ahead cannot be changed	
	ICC is not canceled when the A/T selector lever is "N" position	Refer to <a href="#">CCS-124, "Description"</a>
Display/Chime	ICC system display not appear	Refer to <a href="#">MWI-62, "On Board Diagnosis Function"</a>
	Chime does not sound	Refer to <a href="#">CCS-125, "Description"</a>
Control	Driving force is hunting	Refer to <a href="#">CCS-127, "Description"</a>
Function to detect a vehicle ahead	System frequently cannot detect a vehicle ahead	Refer to <a href="#">CCS-128, "Description"</a>
	Distance to detect a vehicle ahead is short	
	System misidentifies a vehicle even though there is no vehicle ahead	<ul style="list-style-type: none"> <li>Perform radar alignment: Refer to <a href="#">CCS-83, "TYPE 1 : Description"</a></li> <li>Perform ICC system action test. Refer to <a href="#">CCS-95, "Description"</a></li> </ul>
	System misidentifies a vehicle in the next lane	
	System does not detect a vehicle at all	Refer to <a href="#">CCS-130, "Description"</a>

A  
B  
C  
D  
E  
F  
G  
H  
I  
J  
K  
L  
M  
N  
P



# MAIN SWITCH DOES NOT TURN ON, MAIN SWITCH DOES NOT TURN OFF

< SYMPTOM DIAGNOSIS >

[ICC]

## MAIN SWITCH DOES NOT TURN ON, MAIN SWITCH DOES NOT TURN OFF

### Description

INFOID:000000009644277

MAIN switch does not turn ON

- ICC system display does not appear even when MAIN switch is pressed.

MAIN switch does not turn OFF

- When ICC system display is ON, display does not turn OFF even if MAIN switch is pressed.

#### NOTE:

When ICC system warning illuminates, perform the self-diagnosis of ICC system, and then repair or replace the malfunctioning parts.

### Diagnosis Procedure

INFOID:000000009644278

#### 1.MAIN SWITCH INSPECTION

1. Start the engine.
2. Check that "MAIN SW" and "CRUISE LAMP" operate normally in "DATA MONITOR" of "ICC/ADAS" with CONSULT.

Is the inspection result normal?

- YES >> GO TO 2.
- NO >> GO TO 4.

#### 2.CHECK COMBINATION METER

Check that "CRUISE IND" operates normally in "DATA MONITOR" of "METER/M&A".

Is the inspection result normal?

- YES >> GO TO 3.
- NO >> GO TO 4.

#### 3.PERFORM SELF-DIAGNOSIS OF COMBINATION METER

1. Perform "Self Diagnostic Result" of "METER/M&A".
2. Check if DTC is detected. Refer to [MWI-80, "DTC Index"](#).

Is any DTC detected?

- YES >> Repair or replace malfunctioning parts.
- NO >> GO TO 4.

#### 4.PERFORM SELF-DIAGNOSIS RESULTS OF ICC SYSTEM

1. Perform "All DTC Reading".
2. Check if the "U1000" is detected in self-diagnosis results of "ICC/ADAS".

Is "U1000" detected?

- YES >> GO TO 5.
- NO >> GO TO 6.

#### 5.CAN COMMUNICATIONS INSPECTION

Check the CAN communication and repair or replace malfunctioning parts. Refer to [CCS-116, "DTC Logic"](#).

>> INSPECTION END

#### 6.CHECK ICC STEERING SWITCH

Check the ICC steering switch. Refer to [DAS-80, "Diagnosis Procedure"](#).

>> INSPECTION END



# ICC SYSTEM CANNOT BE SET (MAIN SWITCH TURNS ON/OFF)

< SYMPTOM DIAGNOSIS >

[ICC]

## ICC SYSTEM CANNOT BE SET (MAIN SWITCH TURNS ON/OFF)

### Description

INFOID:000000009644279

The MAIN switch can be turned ON/OFF, but the ICC system cannot be set even if the SET/COAST switch is pressed.

#### NOTE:

The system cannot be set in the following case.

- When the vehicle ahead is not detected below the speed of 32 km/h (20 MPH).
- When the selector lever is not in the "D" position or manual mode.
- When the brake pedal is depressed.
- When the VDC is turned OFF.
- When ABS or VDC (including the TCS) operates.
- When a wheel slips.
- When ABS warning lamp is ON.
- When drive mode select switch is in SNOW position.
- When the radar is temporarily interrupted.

### Diagnosis Procedure

INFOID:000000009644280

#### 1. CHECK CAUSE OF AUTOMATIC CANCELLATION

Check if there is the cancellation cause in the "CAUSE OF AUTO-CANCEL" on "WORK SUPPORT" of "ICC/ADAS" with CONSULT.

##### Is it displayed?

Not displayed >> GO TO 2.

"OPE SW VOLT CIRC" >> Refer to [DAS-80, "DTC Logic"](#).

"VHCL SPD UNMATCH" >> Refer to [DAS-72, "DTC Logic"](#).

"IGN LOW VOLT" >> Refer to [CCS-102, "DTC Logic"](#).

"ECM CIRCUIT" >> Refer to [DAS-89, "DTC Logic"](#).

"CAN COMM ERROR" >> Refer to [DAS-122, "DTC Logic"](#).

"ICC SENSOR CAN COMM ERR" >> Refer to [DAS-122, "DTC Logic"](#).

"ABS/TCS/VDC CIRC" >> Refer to [DAS-74, "DTC Logic"](#).

"ECD CIRCUIT" >> Refer to [DAS-95, "DTC Logic"](#).

#### 2. PERFORM THE SELF-DIAGNOSIS

1. Perform "All DTC Reading".
2. Check if any DTC is detected in "Self Diagnostic Result" of "ICC/ADAS" or "LASER/RADAR". Refer to [CCS-58, "DTC Index"](#) (ICC/ADAS) or [CCS-63, "DTC Index"](#) (LASER/RADAR).

##### Is any DTC detected?

YES >> GO TO 3.

NO >> GO TO 4.

#### 3. REPAIR OR REPLACE MALFUNCTIONING PARTS

Repair or replace malfunctioning parts identified by the self-diagnosis result.

>> GO TO 6.

#### 4. CHECK EACH SWITCH AND VEHICLE SPEED SIGNAL

1. Start the engine.
2. Check that the following items operate normally in "DATA MONITOR" of "ICC/ADAS".
  - "VHCL SPEED SE"
  - "D RANGE SW"
  - "SET/COAST SW"
  - "BRAKE SW"
  - "PKB SW"

##### Is there a malfunctioning item?

All items are normal >> GO TO 5.

"VHCL SPEED SE" >> Refer to [DAS-72, "DTC Logic"](#).

"D RANGE SW" >> Refer to [CCS-124, "Diagnosis Procedure"](#).

## ICC SYSTEM CANNOT BE SET (MAIN SWITCH TURNS ON/OFF)

< SYMPTOM DIAGNOSIS >

[ICC]

---

“SET/COAST SW”>>Refer to [DAS-80, "DTC Logic"](#).

“BRAKE SW”>>Refer to [DAS-75, "DTC Logic"](#).

“PKB SW”>>Refer to [WCS-56, "Diagnosis Procedure"](#).

### 5.REPLACE ADAS CONTROL UNIT

---

Replace the ADAS control unit. Refer to [DAS-161, "Removal and Installation"](#).

>> GO TO 6.

### 6.CHECK ICC SYSTEM

---

1. Erase the self-diagnosis results, and then perform “All DTC Reading” again after performing the action test. (Refer to [CCS-95, "Description"](#) for action test.)
2. Check that the ICC system is normal.

>> INSPECTION END

# ICC STEERING SWITCH (OTHER THAN MAIN SWITCH) DOES NOT FUNCTION

< SYMPTOM DIAGNOSIS >

[ICC]

## ICC STEERING SWITCH (OTHER THAN MAIN SWITCH) DOES NOT FUNCTION

### Description

INFOID:000000009644281

ICC MAIN switch can be turned ON/OFF, but the operation of RESUME/ACCELERATE switch, CANCEL switch, and DISTANCE switch cannot be performed during ICC system operation.

#### NOTE:

Resume is not accepted when the following condition is met.

- When the MAIN switch is turned OFF once.

The set distance change is not accepted when any of the following condition is met.

- When the DCA system is turned ON.

### Diagnosis Procedure

INFOID:000000009644282

#### 1. CHECK EACH SWITCH

1. Start the engine.
2. Check that each switch operates normally on "DATA MONITOR" of "ICC/ADAS" with CONSULT.
  - "RESUME/ACC SW"
  - "CANCEL SW"
  - "DISTANCE SW"

Is the inspection result normal?

YES >> GO TO 5.

NO >> GO TO 2.

#### 2. PERFORM ALL OF THE SELF-DIAGNOSIS ITEMS

1. Perform "All DTC Reading".
2. Check if the "U1000" is detected in "Self Diagnostic Result" of "ICC/ADAS".

Is "U1000" detected?

YES >> GO TO 3.

NO >> GO TO 4.

#### 3. CAN COMMUNICATIONS INSPECTION

Check the CAN communication and repair or replace malfunctioning parts. Refer to [CCS-116, "DTC Logic"](#).

>> INSPECTION END

#### 4. CHECK ICC STEERING SWITCH

Check the ICC steering switch. Refer to [DAS-81, "Component Inspection"](#).

>> GO TO 6.

#### 5. REPLACE ADAS CONTROL UNIT

Replace the ADAS control unit. Refer to [DAS-161, "Removal and Installation"](#).

>> GO TO 6.

#### 6. CHECK ICC SYSTEM

1. Erase the self-diagnosis results, and then perform "All DTC Reading" again after performing the action test. (Refer to [CCS-95, "Description"](#) for action test.)
2. Check that the ICC system is normal.

>> INSPECTION END

# ICC SYSTEM DOES NOT CANCEL WHEN A/T SELECTOR LEVER SETS ON "N" [ICC]

< SYMPTOM DIAGNOSIS >

## ICC SYSTEM DOES NOT CANCEL WHEN A/T SELECTOR LEVER SETS ON "N"

### Description

INFOID:000000009644283

The ICC system is not canceled even when the A/T selector lever is shifted to the N position while the ICC system is active.

### Diagnosis Procedure

INFOID:000000009644284

#### 1. CHECK D RANGE SWITCH

Check if "D RANGE SW" operates normally in "DATA MONITOR" of "ICC/ADAS" with CONSULT.

Is the inspection result normal?

- YES >> GO TO 6.
- NO >> GO TO 2.

#### 2. PERFORM ALL SELF-DIAGNOSIS ITEMS

1. Perform "All DTC Reading".
2. Check if the "U1000" is detected in "self-diagnosis results" of "ICC/ADAS".

Is "U1000" detected?

- YES >> GO TO 3.
- NO >> GO TO 4.

#### 3. CAN COMMUNICATIONS INSPECTION

Check the CAN communication and repair or replace malfunctioning parts. Refer to [CCS-116. "DTC Logic"](#).

>> INSPECTION END

#### 4. CHECK POSITION SWITCH

Check if "SLCT LVR POSI" operates normally in "DATA MONITOR" of "TRANSMISSION".

Is the inspection result normal?

- YES >> GO TO 6.
- NO >> GO TO 5.

#### 5. PERFORM TCM SELF-DIAGNOSIS

1. Perform the "Self Diagnostic Result" of "TRANSMISSION".
2. Repair or replace malfunctioning parts. Refer to [TM-85. "DTC Index"](#).

>> GO TO 7.

#### 6. REPLACE ADAS CONTROL UNIT

Replace the ADAS control unit. Refer to [DAS-161. "Removal and Installation"](#).

>> GO TO 7.

#### 7. CHECK ICC SYSTEM

1. Erase the self-diagnosis results, and then perform "All DTC Reading" again after performing the action test. (Refer to [CCS-95. "Description"](#) for action test.)
2. Check that the ICC system is normal.

>> INSPECTION END

# CHIME DOES NOT SOUND

< SYMPTOM DIAGNOSIS >

[ICC]

## CHIME DOES NOT SOUND

### Description

INFOID:000000009644285

Symptom check: In the following conditions, the warning chime may not sound even if the vehicle distance is short.

- When the vehicles are traveling at the same speed and the distance between vehicles is not changing.
- When the vehicle ahead is traveling faster and the distance between vehicles is increasing.
- The warning chime will not sound when the accelerator pedal is depressed, overriding the system.
- The warning chime will not sound when own vehicle approaches vehicles that are parked or moving slowly.
- The warning chime does not sound when the system does not detect any vehicle ahead. (Diagnose the conditions under which the system is detecting the vehicle ahead and when the system is malfunctioning. If there is any malfunction in detecting the vehicle ahead, check the system following the [CCS-128, "Description"](#).)

### Diagnosis Procedure

INFOID:000000009644286

#### 1.PERFORM ACTIVE TEST

Check if the warning chime sounds on the active test item "ICC BUZZER" of "ICC/ADAS" with CONSULT.

Does the warning chime sound?

YES >> GO TO 2.

NO >> GO TO 3.

#### 2.CHECK THE MALFUNCTION SYMPTOM DURING WARNING CHIME OPERATION

Understand the vehicle ahead detecting condition when the malfunction occurred. If the warning chime should have sounded, replace the ADAS control unit. Refer to [DAS-161, "Removal and Installation"](#).

>> GO TO 8.

#### 3.CHECK DRIVER ASSISTANCE BUZZER

Check if the warning chime sounds on the active test item BUZZER 2 (ADAS) of "BSW/BUZZER" with CONSULT.

Is the inspection result normal?

YES >> GO TO 4.

NO >> GO TO 5.

#### 4.PERFORM THE SELF-DIAGNOSIS OF ADAS CONTROL UNIT

1. Perform "All DTC Reading" with CONSULT.

2. Check if the any DTC is detected in self-diagnosis results of "ICC/ADAS".

Is any DTC detected?

YES >> GO TO 6.

NO >> GO TO 5.

#### 5.PERFORM THE SELF-DIAGNOSIS OF DRIVER ASSISTANCE BUZZER CONTROL MODULE

1. Perform "All DTC Reading" with CONSULT.

2. Check if the "any DTC" is detected in self-diagnosis results of "BSW/BUZZER".

Is "any DTC" detected?

YES >> GO TO 6.

NO >> GO TO 7.

#### 6.REPAIR OR REPLACE MALFUNCTIONING PARTS

Repair or replace malfunctioning parts.

>> GO TO 8.

#### 7.REPLACE ADAS CONTROL UNIT

Replace the ADAS control unit. Refer to [DAS-161, "Removal and Installation"](#).

## CHIME DOES NOT SOUND

< SYMPTOM DIAGNOSIS >

[ICC]

---

>> GO TO 8.

### 8.CHECK ICC SYSTEM

---

1. Erase the self-diagnosis results, and then perform "All DTC Reading" again after performing the action test. (Refer to [CCS-95. "Description"](#) for action test.)
2. Check that the ICC system is normal.

>> INSPECTION END

# DRIVING FORCE IS HUNTING

< SYMPTOM DIAGNOSIS >

[ICC]

## DRIVING FORCE IS HUNTING

### Description

INFOID:000000009644287

The vehicle causes hunting when the ICC system is active.

### Diagnosis Procedure

INFOID:000000009644288

#### 1.PERFORM SELF-DIAGNOSIS OF ECM

1. Perform "All DTC Reading" with CONSULT.
2. Check if the DTC is detected in self-diagnosis results of "ENGINE". Refer to [EC-106, "DTC Index"](#).

##### Is any DTC detected?

- YES >> GO TO 3.  
NO >> GO TO 2.

#### 2.CHECK ICC SENSOR

1. Check the vehicle driving conditions. Refer to [CCS-128, "Description"](#).
2. Check the ICC sensor for contamination, foreign materials, or cracks. Refer to [CCS-128, "Diagnosis Procedure"](#).

>> INSPECTION END

#### 3.REPAIR OR REPLACE MALFUNCTIONING PARTS

Repair or replace malfunctioning parts identified by the self-diagnosis result.

>> GO TO 4.

#### 4.CHECK ICC SYSTEM

1. Erase the self-diagnosis results, and then perform "All DTC Reading" again after performing the action test. (Refer to [CCS-95, "Description"](#) for action test.)
2. Check that the ICC system is normal.

>> INSPECTION END

A  
B  
C  
D  
E  
F  
G  
H  
I  
J  
K  
L  
M  
N  
P

CCS

# FREQUENTLY CANNOT DETECT THE VEHICLE AHEAD / DETECTION ZONE IS SHORT

< SYMPTOM DIAGNOSIS >

[ICC]

## FREQUENTLY CANNOT DETECT THE VEHICLE AHEAD / DETECTION ZONE IS SHORT

### Description

INFOID:000000009644289

The detection function may become unstable in the following cases.

- When radar reflections from the vehicle ahead is interrupted.
- When driving a road with extremely sharp corners.
- When the sensor cannot detect a vehicle ahead while the vehicle ahead passes a hill or valley.

### Diagnosis Procedure

INFOID:000000009644290

#### 1.VISUAL CHECK (1)

Check the contamination and foreign matter on the ICC sensor area of the front bumper.

Do foreign matter adhere?

- YES >> GO TO 3.
- NO >> GO TO 2.

#### 2.VISUAL CHECK (2)

1. Remove the front bumper. Refer to [EXT-14, "Removal and Installation"](#).
2. Check ICC sensor for contamination and foreign matter.

Do foreign matter adhere?

- YES >> GO TO 3.
- NO >> GO TO 4.

#### 3.WIPE OUT DIRT AND FOREIGN MATERIALS

Wipe out the contamination and foreign matter in the area around the ICC sensor.

>> GO TO 8.

#### 4.VISUAL CHECK (3)

Check ICC sensor for cracks and scratches.

Are there any cracks or scratches?

- YES >> GO TO 6.
- NO >> GO TO 5.

#### 5.PERFORM RADAR ALIGNMENT

1. Install the front bumper. Refer to [EXT-14, "Removal and Installation"](#).
2. Perform the radar alignment. Refer to [CCS-83, "TYPE 1 : Description"](#).
3. Perform ICC system action test. Refer to [CCS-95, "Description"](#).
4. Check that the vehicle ahead detection performance improves.

Does it improve?

- YES >> INSPECTION END
- NO >> GO TO 6.

#### 6.REPLACE ICC SENSOR

1. Replace the ICC sensor. Refer to [CCS-135, "Exploded View"](#).
2. Install the front bumper. Refer to [EXT-14, "Removal and Installation"](#).
3. Perform the radar alignment. Refer to [CCS-83, "TYPE 1 : Description"](#).
4. Perform ICC system action test. Refer to [CCS-95, "Description"](#).
5. Check that the vehicle ahead detection performance improves.

Does it improve?

- YES >> INSPECTION END
- NO >> GO TO 7.

#### 7.REPLACE ADAS CONTROL UNIT

Replace ADAS control unit. Refer to [DAS-161, "Removal and Installation"](#).



# FREQUENTLY CANNOT DETECT THE VEHICLE AHEAD / DETECTION ZONE IS SHORT

< SYMPTOM DIAGNOSIS >

[ICC]

>> GO TO 8.

## 8. CHECK ICC SYSTEM

1. Erase the self-diagnosis results, and then perform "All DTC Reading" again after performing the action-test. (Refer to [CCS-95. "Description"](#) for action test).
2. Check that the ICC system is normal.

>> INSPECTION END

A

B

C

D

E

F

G

H

I

J

K

L

M

N

CCS

P

# THE SYSTEM DOES NOT DETECT THE VEHICLE AHEAD AT ALL

< SYMPTOM DIAGNOSIS >

[ICC]

---

## THE SYSTEM DOES NOT DETECT THE VEHICLE AHEAD AT ALL

### Description

INFOID:000000009644291

When ICC system is active, the ICC system does not perform any control even through there is a vehicle ahead.

### Diagnosis Procedure

INFOID:000000009644292

---

#### 1. CHECK ICC SYSTEM DISPLAY ON MULTI INFORMATION DISPLAY

1. Start the self-diagnosis mode of combination meter. Refer to [MWI-62, "On Board Diagnosis Function"](#).
2. Check that the multi information display turns on normally.

Is the inspection result normal?

- YES >> GO TO 2.
- NO >> Replace the combination meter.

---

#### 2. VISUAL CHECK (1)

Check the contamination and foreign matter on the ICC sensor area of the front bumper.

Do foreign materials adhere?

- YES >> GO TO 4.
- NO >> GO TO 3.

---

#### 3. VISUAL CHECK (2)

1. Remove the front bumper. Refer to [EXT-14, "Removal and Installation"](#).
2. Check ICC sensor for contamination and foreign matter.

Do foreign matter adhere?

- YES >> GO TO 4.
- NO >> GO TO 5.

---

#### 4. WIPE OUT DIRT AND FOREIGN MATERIALS

Wipe out the contamination and foreign matter in the area around the ICC sensor.

>> GO TO 9.

---

#### 5. VISUAL CHECK (3)

Check ICC sensor for cracks and/or scratches.

Are there cracks?

- YES >> GO TO 7.
- NO >> GO TO 6.

---

#### 6. PERFORM RADAR ALIGNMENT

1. Install the front bumper. Refer to [EXT-14, "Removal and Installation"](#).
2. Perform the radar alignment. Refer to [CCS-83, "TYPE 1 : Description"](#).
3. Perform ICC system action test. Refer to [CCS-95, "Description"](#).
4. Check that the vehicle ahead detection performance improves.

Does it improve?

- YES >> INSPECTION END
- NO >> GO TO 8.

---

#### 7. REPLACE ICC SENSOR

1. Replace the ICC sensor. Refer to [CCS-135, "Exploded View"](#).
2. Install the front bumper. Refer to [EXT-14, "Removal and Installation"](#).
3. Perform the radar alignment. Refer to [CCS-83, "TYPE 1 : Description"](#).
4. Perform ICC system action test. Refer to [CCS-95, "Description"](#).
5. Check that the vehicle ahead detection performance improves.

Does it improve?

- YES >> INSPECTION END

# THE SYSTEM DOES NOT DETECT THE VEHICLE AHEAD AT ALL

< SYMPTOM DIAGNOSIS >

[ICC]

NO >> GO TO 8.

## 8.REPLACE ADAS CONTROL UNIT

Replace ADAS control unit. Refer to [DAS-161, "Removal and Installation"](#).

>> GO TO 9.

## 9.CHECK ICC SYSTEM

1. Erase the self-diagnosis results, and then perform "All DTC Reading" again after performing the action test. (Refer to [CCS-95, "Description"](#) for action test.)
2. Check that the ICC system is normal.

>> INSPECTION END

A  
B  
C  
D  
E  
F  
G  
H  
I  
J  
K  
L  
M  
N  
P

CCS

## NORMAL OPERATING CONDITION

### Description

INFOID:000000009644293

#### PRECAUTIONS FOR VEHICLE-TO-VEHICLE DISTANCE CONTROL MODE

- ICC system is only an aid to assist the driver and is not a collision warning or avoidance device. It is the driver's responsibility to stay alert, drive safely and be in control of the vehicle at all times.
- The system is primarily intended for use on straight, dry, open roads with light traffic. It is not advisable to use the system in city traffic or congested areas.
- This system will not adapt automatically to road conditions. This system should be used in evenly flowing traffic. Do not use the system on roads with sharp curves, or on icy roads, in heavy rain or in fog.
- The ICC sensor will not detect under most conditions.
  - Stationary and slow moving vehicles.
  - Pedestrians or objects in the roadway.
  - Oncoming vehicles in the some lane.
  - Motorcycles traveling offset in the travel lane.
- As there is a performance limit to the distance control function, never rely solely on the ICC system. This system does not correct careless, inattentive or absent-minded driving, or overcome poor visibility in rain, fog, or other bad weather. Decelerate the vehicle speed by depressing the brake pedal, depending on the distance to the vehicle ahead and the surrounding circumstances in order to maintain a safe distance between vehicles.
- If the vehicle ahead comes to a stop, the vehicle decelerates to a standstill within the limitations of the system. The system will cancel once it judges that the vehicle has come to a standstill and sound a warning chime. To prevent the vehicle from moving, the driver must depress the brake pedal.
- The system may not detect the vehicle in front of the driver in certain road or weather conditions. To avoid accidents, never use the ICC system under the following conditions:
  - On roads where the traffic is heavy or there are sharp curves.
  - On slippery road surfaces such as on ice or snow, etc.
  - During bad weather (rain, fog, snow, etc.)
  - When rain, snow or dirt adhere to the system sensor.
  - On steep downhill roads (the vehicle may go beyond the set vehicle speed and frequent braking may result in overheating the brakes).
  - On repeated uphill and downhill roads.
  - When traffic conditions make it difficult to keep a proper distance between vehicles because of frequent acceleration or deceleration.
- In some road or traffic conditions, a vehicle or object can unexpectedly come into the sensor detection zone and cause automatic braking. The driver may need to control the distance from other vehicles using the accelerator pedal. Always stay alert and avoid using the ICC system when it is not recommended in this section.
- The vehicle-to-vehicle distance control mode uses a sensor located behind the lower grille of the front bumper to detect vehicles traveling ahead. The sensor generally detects the signals returned from the vehicle ahead. Therefore, if the sensor cannot detect the reflection from the vehicle ahead, the ICC system may not maintain the selected distance.
  - The following are some conditions in which the sensor cannot detect the signals:
    - When the snow or road spray from traveling vehicles reduces the sensor's visibility.
    - When excessively heavy baggage is loaded in the rear seat or the trunk room of own vehicle.
- The ICC system is designed to automatically check the sensor's operation within the limitation of the system. When the sensor area of the front bumper is covered with dirt or is obstructed, the system will automatically be canceled. If the sensor is covered with ice, a transparent or translucent vinyl bag, etc., the ICC system may not detect them. In these instances, the vehicle-to-vehicle distance control mode may not cancel and may not be able to maintain the selected following distance from the vehicle ahead. Be sure to check and clean the sensor regularly.
- The ICC system does not control vehicle speed or warn the driver when own vehicle approaches stationary and slow moving vehicles. The driver must pay attention to vehicle operation to maintain proper distance from vehicles ahead when approaching toll gates or traffic congestion.

# NORMAL OPERATING CONDITION

[ICC]

## < SYMPTOM DIAGNOSIS >

- The detection zone of the ICC sensor is limited. A vehicle ahead must be in the detection zone for the vehicle-to-vehicle distance detection mode to maintain the selected distance from the vehicle ahead. A vehicle ahead may move outside of the detection zone due to its position within the same lane of travel. Motorcycles may not be detected in the same lane ahead if they are traveling offset from the center line of the lane. A vehicle that is entering the lane ahead may not be detected until the vehicle has completely moved into the lane. If this occurs, the ICC system may warn the driver by blinking the system indicator and sounding the chime. The driver may have to manually control the proper distance away from vehicle traveling ahead.

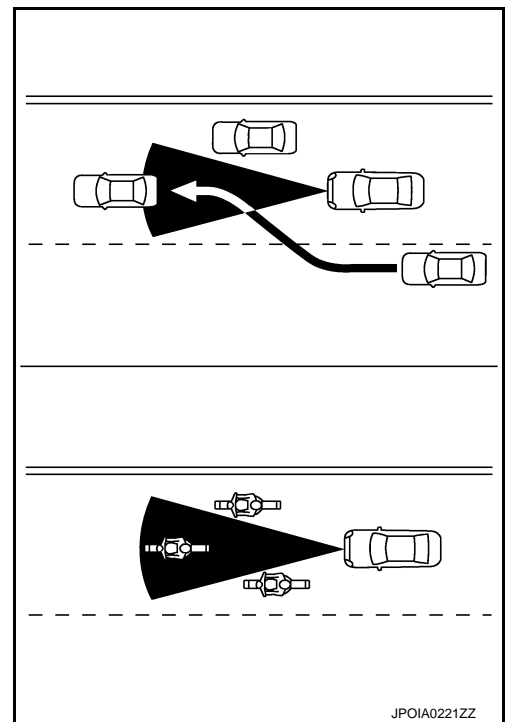

- When driving on some roads, such as winding, hilly, curved, narrow roads, or roads which are under construction, the ICC sensor may detect vehicles in a different lane, or may temporarily not detect a vehicle traveling ahead. This may cause the ICC system to decelerate or accelerate the vehicle. The detection of vehicles may also be affected by vehicle operation (steering maneuver or traveling position in the lane, etc.) or vehicle condition. If this occurs, the ICC system may warn the driver by blinking the system indicator and sounding the chime unexpectedly. The driver will have to manually control the proper distance away from the vehicle traveling ahead.

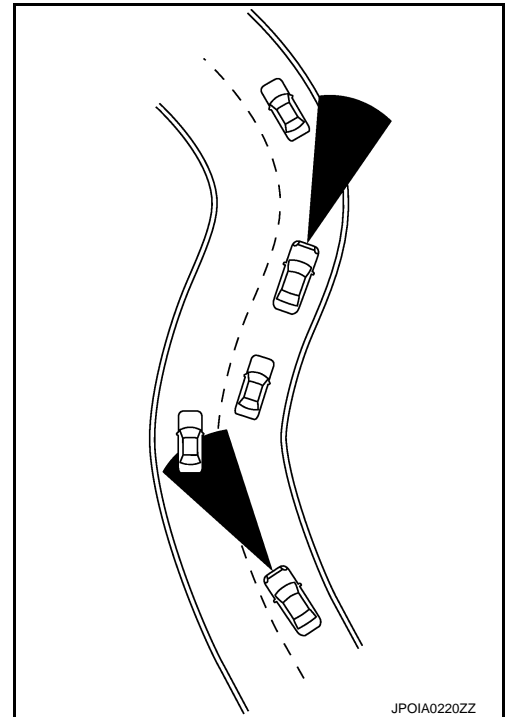

- When driving on the freeway at a set speed and approaching a slower traveling vehicle ahead, the ICC will adjust the speed to maintain the distance, selected by the driver, from the vehicle ahead. If the vehicle ahead changes lanes or exits the freeway, the ICC system will accelerate and maintain the speed up to the set speed. Pay attention to the driving operation to maintain control of the vehicle as it accelerates to the set speed. The vehicle may not maintain the set speed on winding or hilly roads. If this occurs, the driver will have to manually control the vehicle speed.

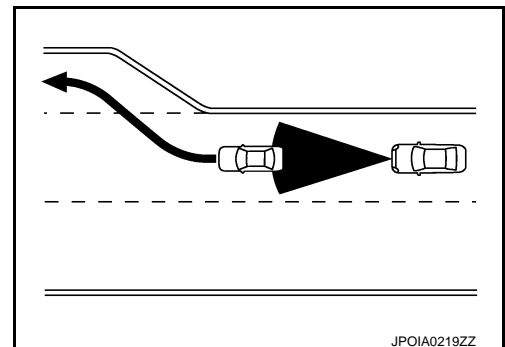

A  
B  
C  
D  
E  
F  
G  
H  
I  
J  
K  
L  
M  
N

CCS

P

## NORMAL OPERATING CONDITION

< SYMPTOM DIAGNOSIS >

[ICC]

- Normally when controlling the distance to a vehicle ahead, this system automatically accelerates or decelerates own vehicle according to the speed of the vehicle ahead. Depress the accelerator to properly accelerate own vehicle when acceleration is required for a lane change. Depress the brake pedal when deceleration is required to maintain a safe distance to the vehicle ahead due to its sudden braking or if a vehicle cuts in. Always stay alert when using the ICC system.

### PRECAUTIONS FOR CONVENTIONAL (FIXED SPEED) CRUISE CONTROL MODE

- In the conventional (fixed speed) cruise control mode, a warning chime does not sound to warn the driver if own vehicle is too close to the vehicle ahead, as neither the presence of the vehicle ahead nor the vehicle-to-vehicle distance is detected.
- Pay special attention to the distance between own vehicle and the vehicle ahead or a collision could occur.
- Always confirm the setting in the ICC system display.
- Do not use the conventional (fixed speed) cruise control mode when driving under the following conditions:
  - When it is not possible to keep the vehicle at a set speed.
  - In heavy traffic or in traffic that varies in speed.
  - On winding or hilly roads.
  - On slippery roads (rain, snow, ice, etc.).
  - In very windy areas.
  - Doing so could cause a loss of vehicle control and result in an accident.
  - To avoid accidentally engaging cruise control, make sure to turn the MAIN switch off when not using the ICC system.

# ICC SENSOR

< REMOVAL AND INSTALLATION >

[ICC]

## REMOVAL AND INSTALLATION

### ICC SENSOR

#### Exploded View

INFOID:000000009644294

#### CAUTION:

Always perform the laser beam aiming adjustment and check the operation after the replacement, removal and installation of ICC sensor.

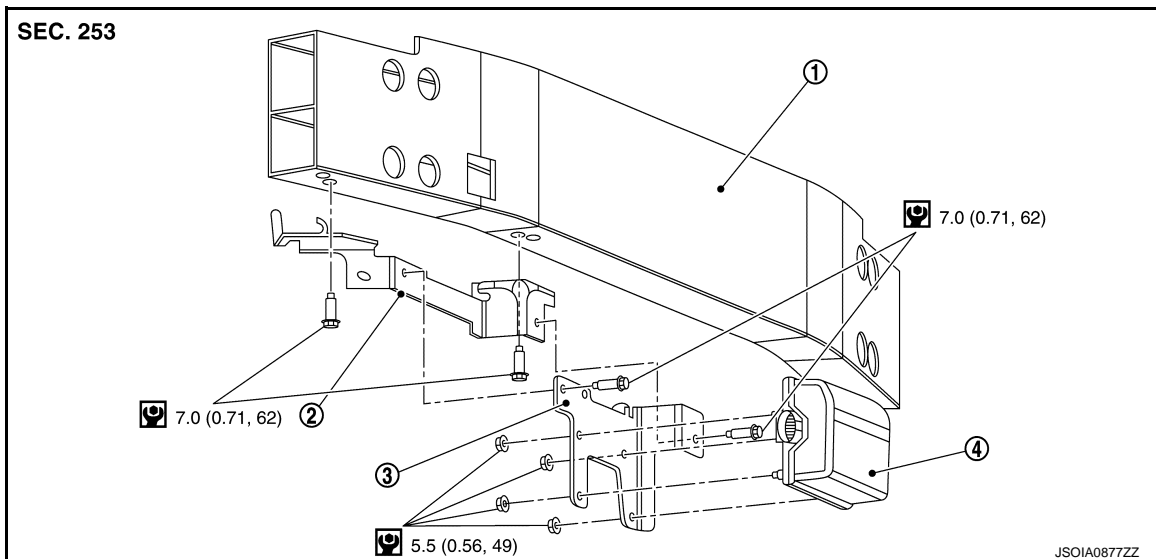

① Front bumper reinforcement

② bracket A

③ bracket B

④ ICC sensor

 : N·m (kg-m, in-lb)

### Removal and Installation

INFOID:000000009644295

#### REMOVAL

1. Remove front bumper fascia. Refer to [EXT-14, "Removal and Installation"](#).
2. Disconnect ICC sensor connector.
3. Remove mounting bolts (A) of bracket A to remove ICC sensor with bracket A.

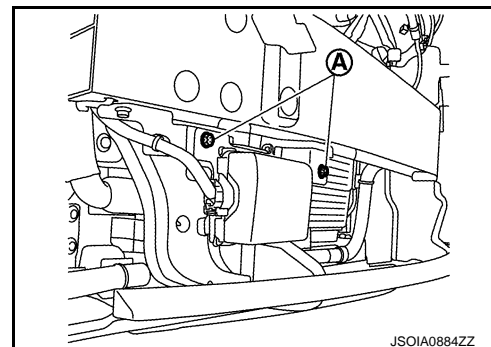

A  
B  
C  
D  
E  
F  
G  
H  
I  
J  
K  
L  
M  
N  
P

CCS

## ICC SENSOR

### < REMOVAL AND INSTALLATION >

[ICC]

4. Remove mounting nuts (A) of ICC sensor.

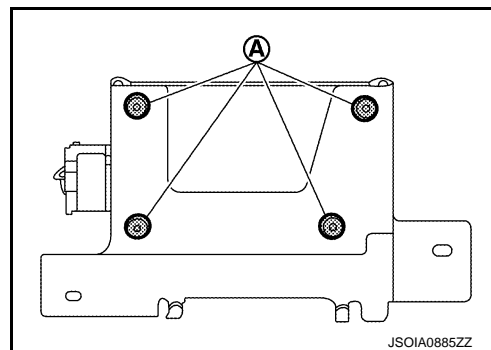

5. Remove ICC sensor.
6. Remove mounting bolts of bracket B to remove bracket B from front bumper reinforcement.

### INSTALLATION

Install in the reverse order of removal.

#### **CAUTION:**

Always perform the radar alignment and check the operation after the replacement, removal, and installation of ICC sensor. Refer to [CCS-82, "Description"](#).



# ICC STEERING SWITCH

< REMOVAL AND INSTALLATION >

[ICC]

## ICC STEERING SWITCH

### Exploded View

INFOID:000000009644296

ICC steering switch is integrated in the steering switch.

Refer to [ST-86. "Removal and Installation"](#).

**NOTE:**

Always remove ICC steering switch together with steering wheel.

A  
B  
C  
D  
E  
F  
G  
H  
I  
J  
K  
L  
M  
N  
P



## AUTOMATIC SPEED CONTROL DEVICE (ASCD)

< SYSTEM DESCRIPTION >

[ASCD]

---

### SYSTEM DESCRIPTION

#### AUTOMATIC SPEED CONTROL DEVICE (ASCD)

##### Information

INFOID:000000009240444

Automatic Speed Control Device (ASCD) system is controlled by ECM.

Regarding the information for ASCD system, refer to [EC-48, "AUTOMATIC SPEED CONTROL DEVICE \(ASCD\) : System Description"](#).